

The Harman Kardon Model T60

Manual No. 49A

FLOATING SUSPENSION AUTO-LIFT TURNTABLE

Technical Manual

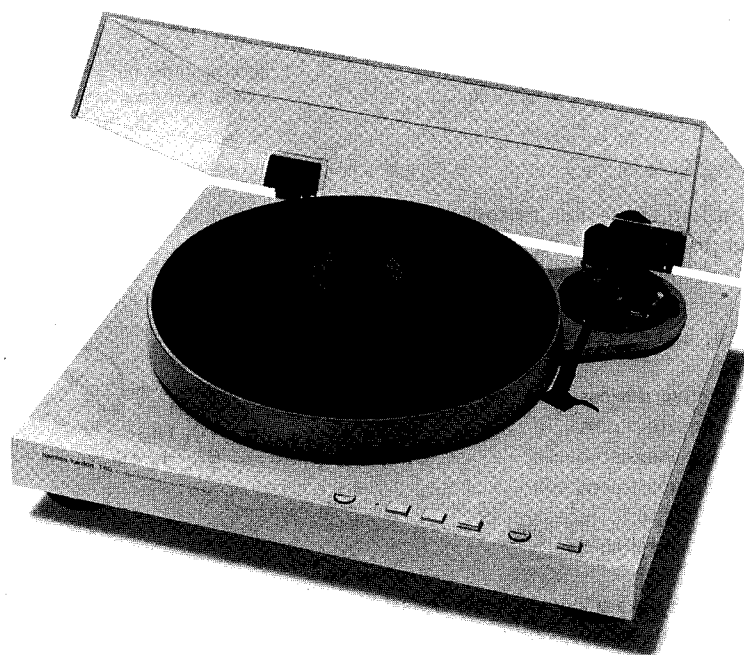

harman/kardon

240 CROSSWAYS PARK WEST, WOODBURY, N.Y. 11797
PRINTED IN JAPAN 1112-H15249A9 P-08825

T60

CONTENTS

SPECIFICATIONS	2	GENERAL UNIT PARTS LIST	11
LEAKAGE TEST	2	ELECTRICAL PARTS LIST	12, 13
COMPONENTS	3	PACKAGE	14
INTERNAL VIEW	4	SCHEMATIC DIAGRAM	15
DISASSEMBLY PROCEDURES	4, 5	IC FUNCTIONAL BLOCK DIAGRAM	15
CARTRIDGE REPLACEMENT INSTRUCTION ...	6	BLOCK DIAGRAM	15
ALIGNMENT PROCEDURES	7, 8	WIRING DIAGRAM	16
GENERAL UNIT EXPLODED VIEW	9, 10		

SPECIFICATIONS

● Speed	Nominal	Limit
Quartz lock		
33-1/3	±0.1%	+0.5% -0.2%
45	±0.1%	+0.5% -0.2%
Control width		
33-1/3		±3.0%
45		±3.0%
● Wow and Flutter	0.04%	≤ 0.07%
● Signal-to-Noise Ratio	68dB	≥ 60dB
● Possible Cartridge Weights	2.5g ~ 8g	

- **Dimensions (W x H x D)** 17-4/9" x 5-2/3" x 15-1/9"
(443 x 144 x 384 mm)
- **Weight** 20.5 lbs. (9.2 kg)
- **Power Supply** AC 120V, 60Hz
- **Power Consumption** 8W

Specifications and components subject to change without notice. Overall performance will be maintained or improved.

LEAKAGE TEST

Before returning the unit to the user, perform the following safety checks:

1. Inspect all lead dress to make certain that leads are not pinched or that hardware is not lodged between the chassis and other metal parts in the unit.
2. Replace all protective devices such as nonmetallic control knobs, insulating fishpapers, cabinet backs, adjustment and compartment covers or shields, isolation resistor-capacity networks, mechanical insulators, etc.
3. Be sure that no shock hazard exists; check for leakage current using Simpson Model 229 Leakage Tester, standard equipment item No. 21641, RCA Model WT540A or use alternate method as follows:
Plug the AC line cord directly into a 120-volt AC receptacle (do not use an Isolation Transformer for this test). Using two clip leads, connect a 1500 ohm, 10-watt resistor paralleled by a 0.15mf capacitor, in series with all exposed metal cabinet parts and a known earth ground, such as a water pipe or conduit. Use a VTVM or VOM with 1000 ohms per volt, or higher, sensitivity to measure the AC voltage drop across the resistor. (See Diagram.) Move the resistor connection to each exposed metal part having a return path to the chassis (antenna, metal, cabinet, screw heads, knobs and control shafts, escutcheon, etc.) and measure the AC voltage drop across the resistor. (This test should be performed with the power switch in both the On and Off positions.)
A reading of 0.35 volt RMS or more is excessive and indicates a potential shock hazard which must be corrected before returning the unit to the owner.

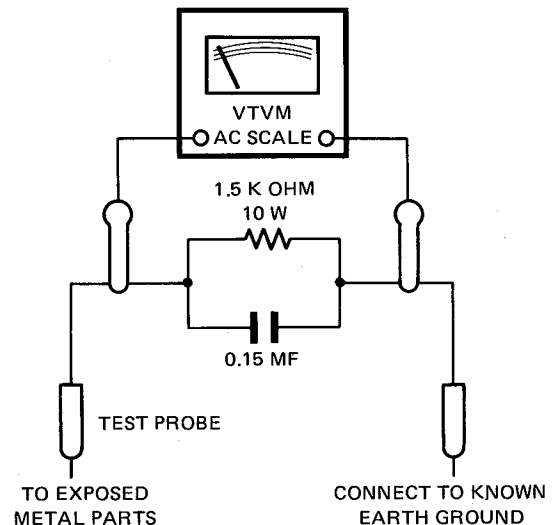
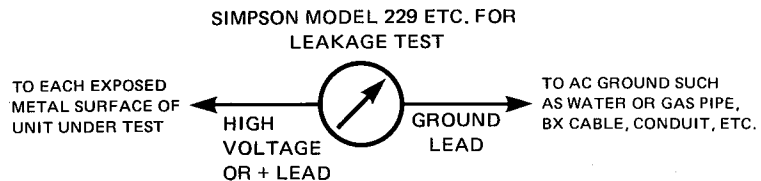

COMPONENTS

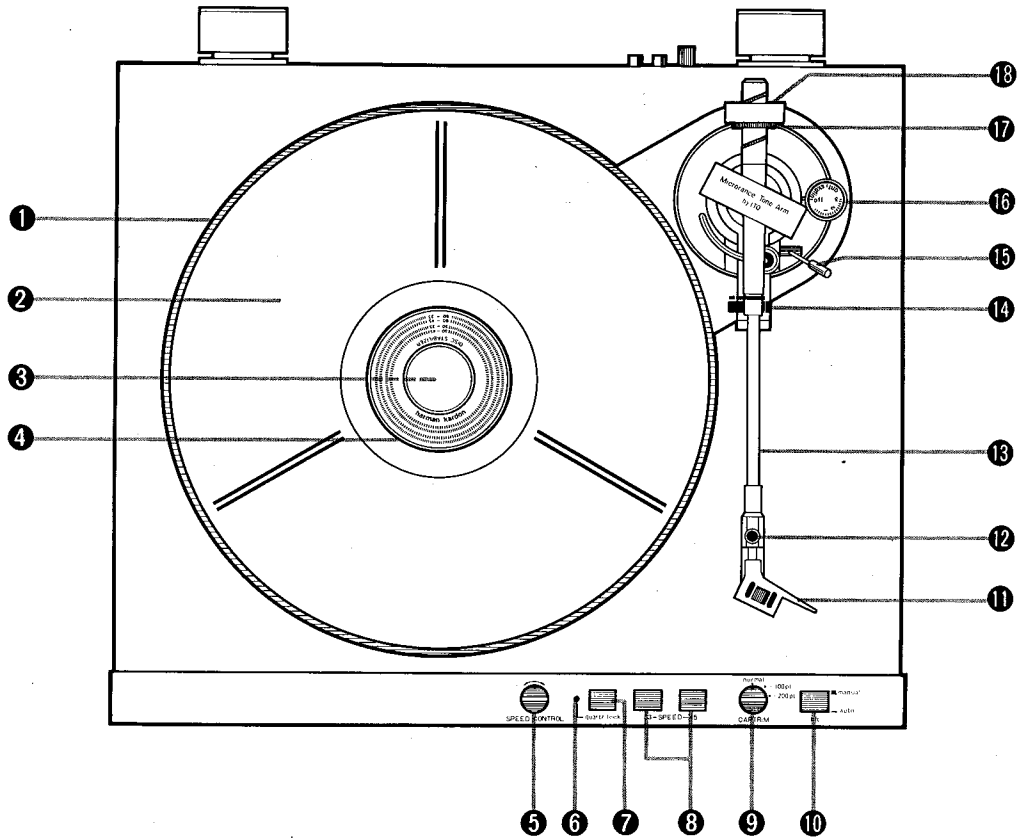

- | | | |
|-------------------------|-----------------------------|-----------------------------|
| ① PLATTER | ⑦ QUARTZ LOCK BUTTON | ⑬ TONEARM |
| ② PLATTER MAT | ⑧ 33/45 SPEED SELECTOR | ⑭ ARMREST/CLAMP |
| ③ CENTER SPINDLE | ⑨ CAPACITANCE TRIM SELECTOR | ⑮ CUE LEVER |
| ④ DISC STABILIZER | ⑩ LIFT BUTTON | ⑯ ANTI-SKATING CONTROL |
| ⑤ SPEED CONTROL | ⑪ HEADSHELL | ⑰ TRACKING FORCE SCALE RING |
| ⑥ QUARTZ LOCK INDICATOR | ⑫ HEADSHELL CLAMP | ⑱ COUNTERWEIGHT |

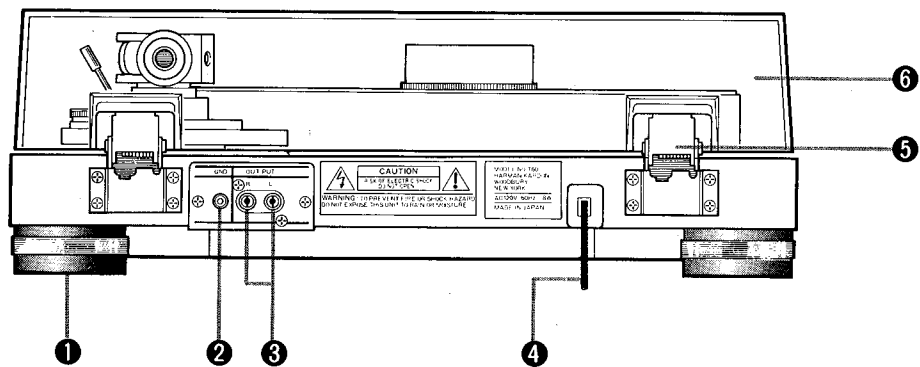

- | | |
|--------------------------|--------------------|
| ① FOOT | ④ AC LINE CORD |
| ② GROUND TERMINAL | ⑤ DUST COVER HINGE |
| ③ SIGNAL OUTPUT TERMINAL | ⑥ DUST COVER |

INTERNAL VIEW

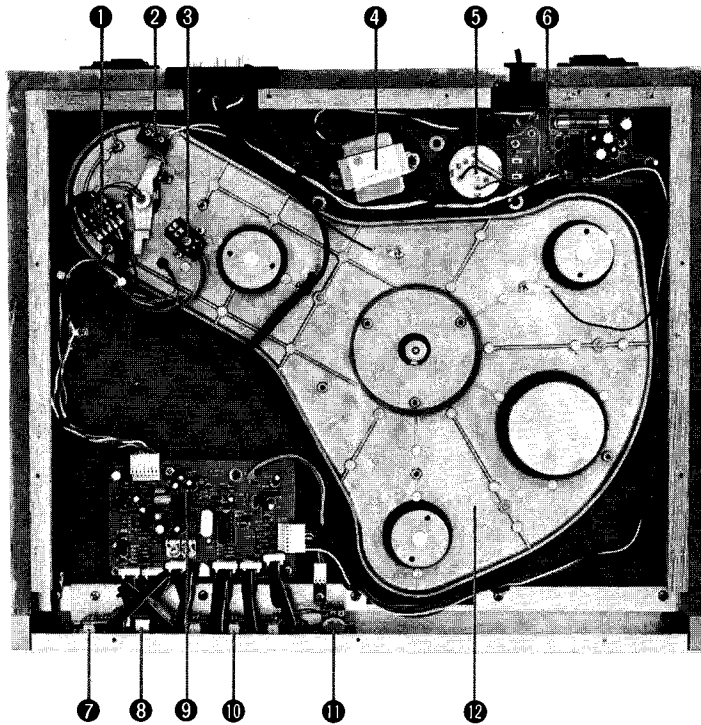

- ① RELAY P.C. BOARD
- ② POWER SWITCH
- ③ LED P.C. BOARD (PCB-4)
& PHOTO TRANSISTOR P.C. BOARD (PCB-5)
- ④ POWER TRANSFORMER
- ⑤ DC MOTOR
- ⑥ POWER SUPPLY P.C. BOARD (PCB-2)
- ⑦ LIFT SWITCH P.C. BOARD (PCB-7)
- ⑧ CAPACITAN TRIM SELECTOR
P.C. BOARD (PCB-6)
- ⑨ MOTOR CONTROL P.C. BOARD (PCB-1)
- ⑩ CONTROL SWITCH P.C. BOARD (PCB-3)
- ⑪ SPEED CONTROL P.C. BOARD (PCB-8)
- ⑫ CHASSIS ASSEMBLY

DISASSEMBLY PROCEDURES

NOTE: Before disassembling the unit, remove the platter and headshell with cartridge, and securely tie the arm to the armrest with string, etc. Then gently turn the unit upside down and place it on cloths, etc. piled up on both sides to protect the arm and cabinet from damage.

1 CABINET BOTTOM REMOVAL

1. Remove screws ① to ⑪ in Fig. 1 and then remove the cabinet bottom.

*Toothed washer is attached to the screw ⑤.

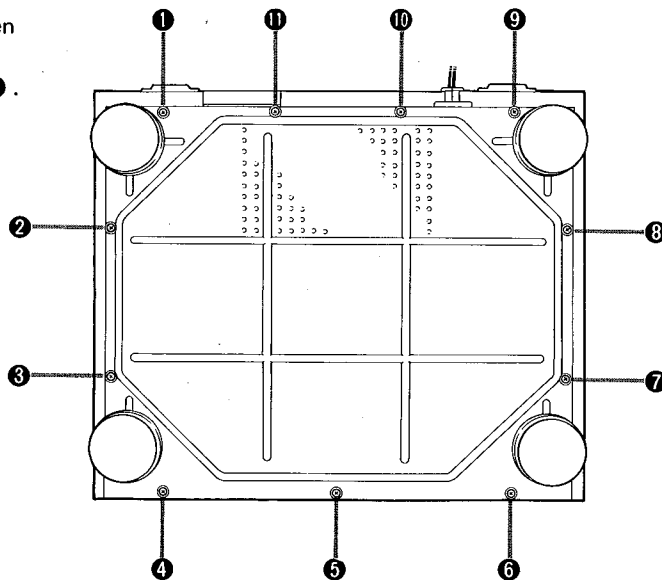

Fig. 1

2 FRONT PANEL REMOVAL

1. Remove the cabinet bottom. (Refer to step 1)
2. Remove screws 1 to 7 in Fig. 2 and remove the switch holder by pulling the front panel slightly forward (at this time remove the lead wires connected to the quartz lock LED) then remove the front panel.

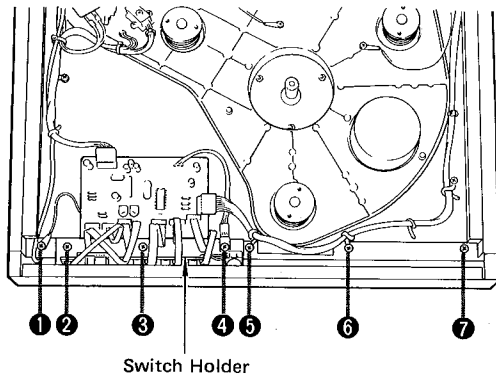

Fig. 2

3 PICK-UP ASSEMBLY REMOVAL

1. Remove the cabinet bottom. (Refer to step 1)
2. Remove the lead wires connected to the solenoid for lifter from terminal, and remove the lead wires connected to the toner arm from relay P.C. board.
3. Loosen screw 1 in Fig. 3 and then remove the lever assembly.
4. Remove screws 2 to 4 in Fig. 3 and then remove the pick-up.

* Be sure to lock the screws 1 to 4 with paint after attaching the pick-up assembly.

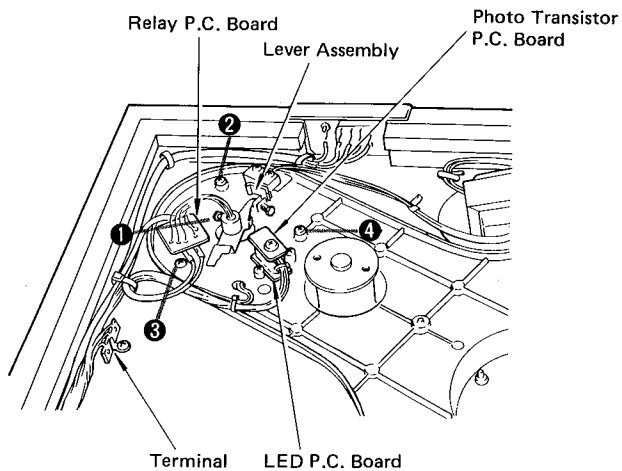

Fig. 3

4 CHASSIS ASSEMBLY REMOVAL

1. Remove the pick-up assembly. (Refer to step 3)
2. Remove the lead wires connected to the relay P.C. board, LED P.C. board, phototransistor P.C. board and chassis.
3. Remove nuts 1 to 3 in Fig. 4 and then remove the chassis assembly by turning the central screws of nuts clockwise.

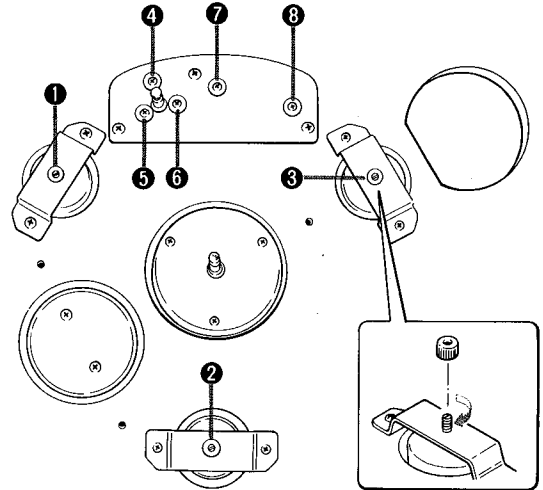

Fig. 4

5 MOTOR REMOVAL

1. Remove the lead wires of the motor.
2. Remove screws 4 to 6 in Fig. 4 and then remove the motor.

6 POWER TRANSFORMER REMOVAL

1. Remove the lead wires connected to the transformer.
2. Remove screws 7 and 8 in Fig. 4 and then remove the power transformer.

CARTRIDGE REPLACEMENT INSTRUCTION

Only use cartridges in the headshell provided. Be sure to use a cartridge weighting 2.5 to 8 grams.

1. Release the tonearm clamp and lift the tonearm gently.
2. Loosen the headshell clamp and gently pull the headshell with cartridge.
3. Disconnect the 4 leads from cartridge terminals using a tweezers and then loosen the retaining screws so that the cartridge comes out.
4. Replace the leads onto the new cartridge. Refer to figure right for correct placement of leads.
5. When all leads are connected properly, install cartridge to the headshell as shown in the figure right.
6. Temporarily tighten the retaining screw to hold the cartridge.
7. Insert the headshell with the cartridge fully into the tonearm and then tighten the headshell clamp.

When cartridge is replaced with new one, it is necessary to adjust the Overhang and Tracking angle.

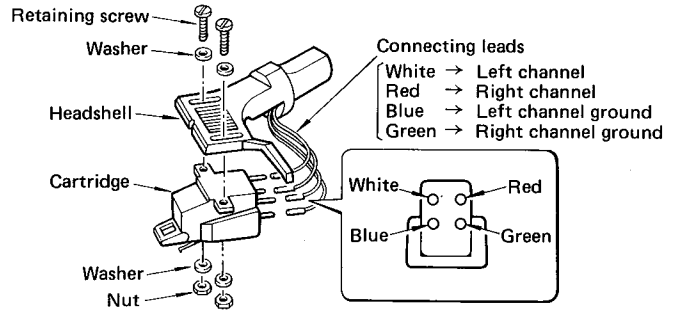
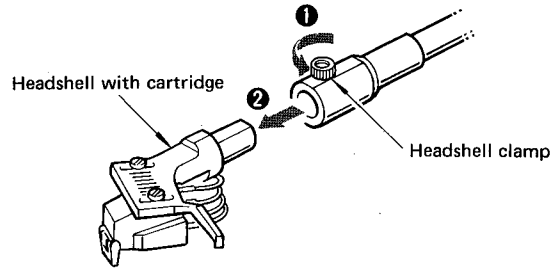

● Overhang Adjustment

1. Place the accessory tracking angle gauge on the center spindle and raise the flap.
2. Be sure to remove the stylus guard when adjusting the overhang.
3. Move the tonearm directly over the center spindle. Line up the raised flap on the gauge with the center spindle and the tonearm base. Gently move the cartridge backward or forward in the headshell so that the stylus tip lines up with the corner of the flap.

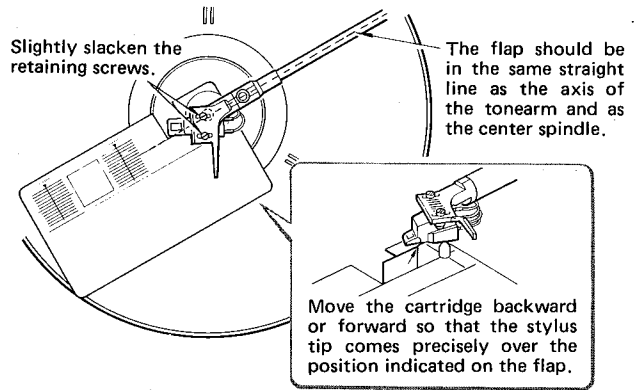

● Tracking Angle Adjustment

1. Check to be sure that the overhang adjustment has been completed.
2. Now move the tracking angle gauge until it is in the same position with respect to the tonearm as that shown in Fig. A. Place the stylus over the tracking angle setting point with keeping stylus guard attached.
3. Without changing the stylus position, turn the cartridge so that its front edge is parallel with the lines on the gauge.
4. Now move it so that it is in the position shown in Fig. B and check that the cartridge is still parallel with the parallel lines as it was in step 3 above. If it is not parallel, then repeat step 3 and 4 alternately until the cartridge is parallel in both cases.
5. When the above adjustment is completed, then tighten the screws that attach the cartridge to the headshell fully.

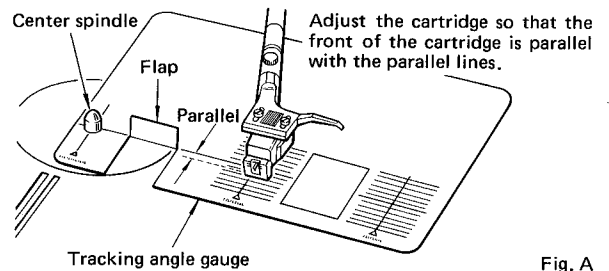

Fig. A

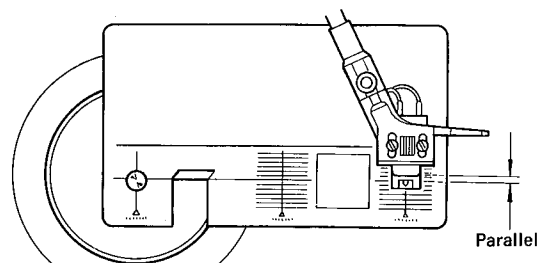
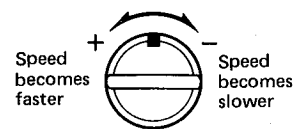

Fig. B

ALIGNMENT PROCEDURES

■ SPEED CONTROL

- Place a disc on the platter mat and then the disc stabilizer with stroboscope on the disc.
- Set the speed selector to 33 or 45 position in accordance with the required disc speed.
- Turn the quartz lock button OFF to release the quartz lock, then adjust the disc speed by turning the speed control knob, with observing the striped markings on the disc stabilizer with stroboscope under fluorescent light.



SPEED CONTROL

■ CAPACITANCE TRIM

The capacitance trim is a capacitance selector switch that enables your cartridge to deliver its optimum performance. Each cartridge had its own characteristic capacitance, and the output leads used to connect the cartridge to the amplifier or receiver also have their own capacitance. Only when these two capacitances are at their optimum values can the cartridge transfer its output and retain its optimum frequency response to the amplifier.

Cartridge capacity	Trim position
Less than 300pF	normal
300 to 400pF	+100pf
Over 400pF	+200pf

- Please read the owner's manual of the cartridge and adjust the trim position accordingly.

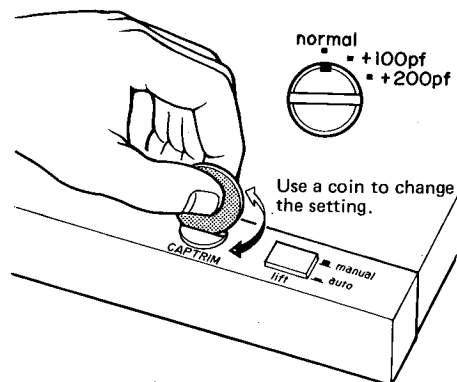
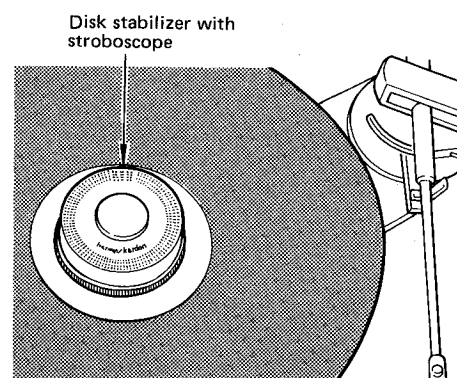

■ SUSPENSION ADJUSTMENT

*Conditions

- Make sure to install the platter, rubber platter mat and disc stabilizer. (It is not necessary for you to hang the drive belt between the platter and motor pulley.)
- Install the cartridge and counter weight to the tonearm. (Set the tracking force to about 2g.) Be sure to place the tonearm on the armrest.
- Be sure that the power is off.

● ADJUSTMENT

- Adjust so that the space between platter and surface of cabinet is 4 mm ± 0.2 mm by turning screws ① to ③ in Fig. 1. (Turning these screws clockwise moves the platter down and turning them counterclockwise moves it up.)
- After adjustments, confirm that the platter moves up and down in the well-balanced condition even if the platter is pressed down in the cabinet.

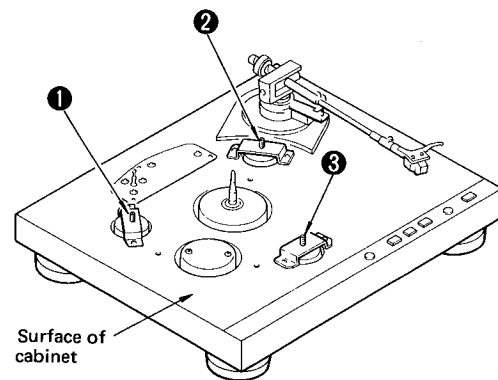

Fig. 1

■ DISC END DETECTION POSITION ADJUSTMENT

*Conditions

Be sure not to hang the drive belt between platter and motor pulley.

Quartz Lock Switch On
Lift Switch Auto

● LP POSITION ADJUSTMENT

- Set the speed selector to 33 r.p.m.
- Lower the cueing lever. (Arm Lifter is set to the low position.)
- Adjust by adjustment screw attached to the lower part of the tonearm so that the stylus of cartridge detects the disc end position between 111.94 mm ~ 107.2 mm from the center of spindle.

● EP POSITION ADJUSTMENT

- Set the speed selector to 45 r.p.m.
- Lower the cueing lever. (Arm Lifter is set to the low position.)
- Adjust by adjustment screw attached to the lower part of the tonearm so that the stylus of cartridge detects the disc end position between 102.74 mm ~ 98.4 mm from the center of spindle.

NOTE:

- Turning the adjustment screw clockwise makes a fast detection of the disc end position, and turning it counterclockwise makes slow detection.
- If it is not within the rate, assumedly, it result from the attached position of lever assembly. Try to change the attaching position by loosening the fixed screw.
- When the disc end position is detected, the motor revolution stops, and arm lifter is raised. If you are going to start it again, place the tonearm on armrest once.

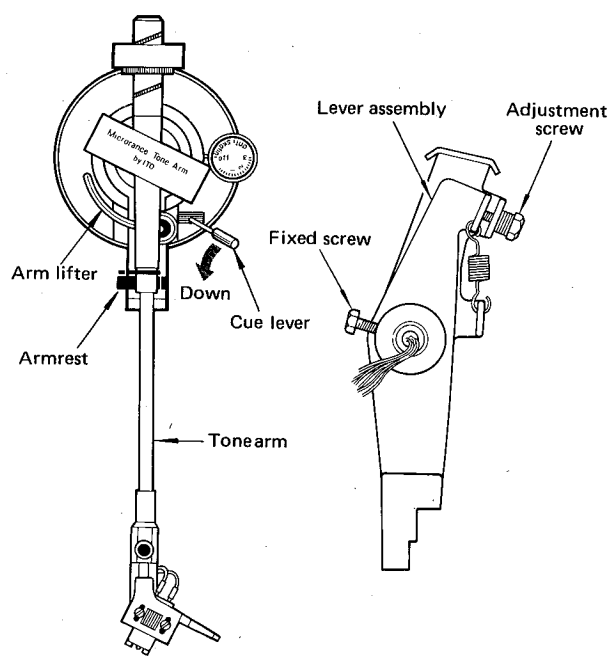

■ MOTOR R.P.M. ADJUSTMENT

*Instrument

Stroboscope or Low range tachometer.

*Condition

- Be sure that the drive belt between platter and motor pulley is hung.
- Flip the cue lever forward to lift the tonearm up.

● QUARTZ LOCK ADJUSTMENT

- Set the speed selector to 33 r.p.m., and set the quartz lock switch to ON.
- Move tonearm horizontally as to be level with the platter, and rotate the platter.
- Measure the motor speed by a stroboscope or low range tachometer.
- Replace the motor pulley when the motor speed is not within the specified range.
- Check the motor speed in the condition that the speed selector is set to 45 r.p.m.

● QUARTZ LOCK OFF ADJUSTMENT

- Set the speed selector to 33 r.p.m. and set the quartz lock switch to OFF, then set the speed control knob at the center.
- Adjust VR101 by turning the platter so that the motor speed rating is within 33-1/3 r.p.m. ± 0.05%.
- Adjust VR102 in the condition that the speed selector is set to 45 r.p.m. so that the motor speed rating is within 45 r.p.m. ± 0.05%.
- After all of these adjustments are over, make sure to confirm that each motor speed make a change more than ±3% with using speed control knob.

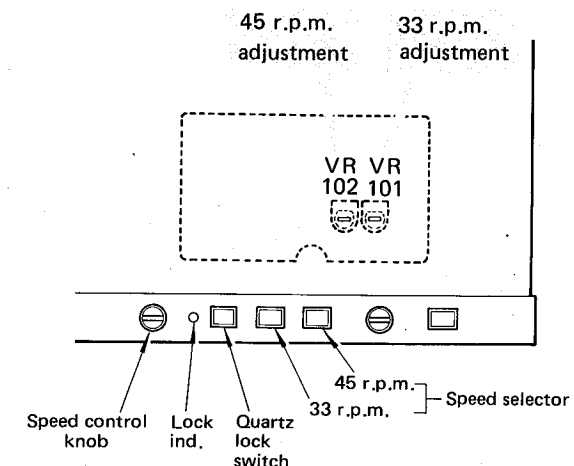
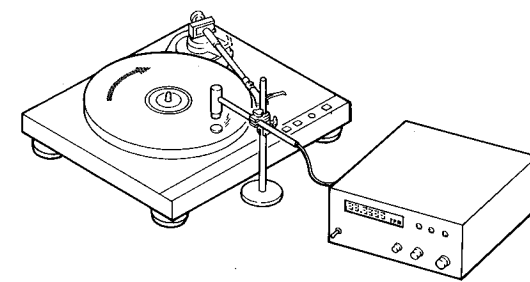

ALIGNMENT PROCEDURES

■ SPEED CONTROL

1. Place a disc on the platter mat and then the disc stabilizer with stroboscope on the disc.
2. Set the speed selector to 33 or 45 position in accordance with the required disc speed.
3. Turn the quartz lock button OFF to release the quartz lock, then adjust the disc speed by turning the speed control knob, with observing the striped markings on the disc stabilizer with stroboscope under fluorescent light.

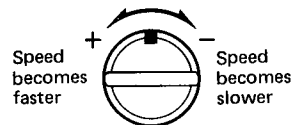

SPEED CONTROL

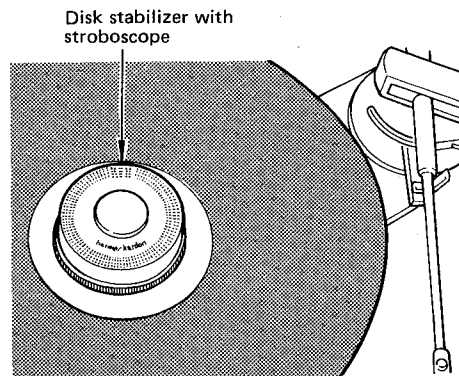

■ CAPACITANCE TRIM

The capacitance trim is a capacitance selector switch that enables your cartridge to deliver its optimum performance. Each cartridge had its own characteristic capacitance, and the output leads used to connect the cartridge to the amplifier or receiver also have their own capacitance. Only when these two capacitances are at their optimum values can the cartridge transfer its output and retain its optimum frequency response to the amplifier.

Cartridge capacity	Trim position
Less than 300pF	normal
300 to 400pF	+100pf
Over 400pF	+200pf

- Please read the owner's manual of the cartridge and adjust the trim position accordingly.

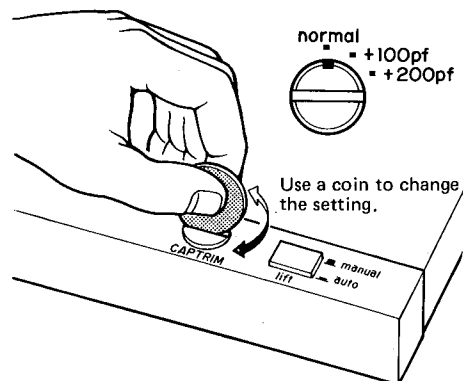

■ SUSPENSION ADJUSTMENT

*Conditions

1. Make sure to install the platter, rubber platter mat and disc stabilizer.
(It is not necessary for you to hang the drive belt between the platter and motor pulley.)
2. Install the cartridge and counter weight to the tonearm. (Set the tracking force to about 2g.)
Be sure to place the tonearm on the armrest.
3. Be sure that the power is off.

● ADJUSTMENT

1. Adjust so that the space between platter and surface of cabinet is 4 mm \pm 0.2 mm by turning screws ① to ③ in Fig. 1.
(Turning these screws clockwise moves the platter down and turning them counterclockwise moves it up.)
2. After adjustments, confirm that the platter moves up and down in the well-balanced condition even if the platter is pressed down in the cabinet.

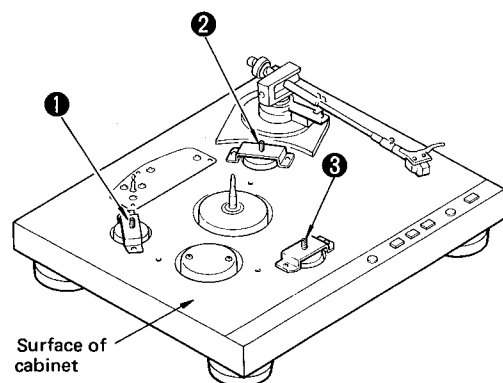

Fig. 1

■ **DISC END DETECTION POSITION ADJUSTMENT**

*Conditions

Be sure not to hang the drive belt between platter and motor pulley.

Quartz Lock Switch On
Lift Switch Auto

● **LP POSITION ADJUSTMENT**

1. Set the speed selector to 33 r.p.m.
2. Lower the cueing lever.
(Arm Lifter is set to the low position.)
3. Adjust by adjustment screw attached to the lower part of the tonearm so that the stylus of cartridge detects the disc end position between 111.94 mm ~ 107.2 mm from the center of spindle.

● **EP POSITION ADJUSTMENT**

1. Set the speed selector to 45 r.p.m.
2. Lower the cueing lever.
(Arm Lifter is set to the low position.)
3. Adjust by adjustment screw attached to the lower part of the tonearm so that the stylus of cartridge detects the disc end position between 102.74 mm ~ 98.4 mm from the center of spindle.

NOTE:

1. Turning the adjustment screw clockwise makes a fast detection of the disc end position, and turning it counterclockwise makes slow detection.
2. If it is not within the rate, assumedly, it result from the attached position of lever assembly.
Try to change the attaching position by loosing the fixed screw.
3. When the disc end position is detected, the motor revolution stops, and arm lifter is raised.
If you are going to start it again, place the tonearm on armrest once.

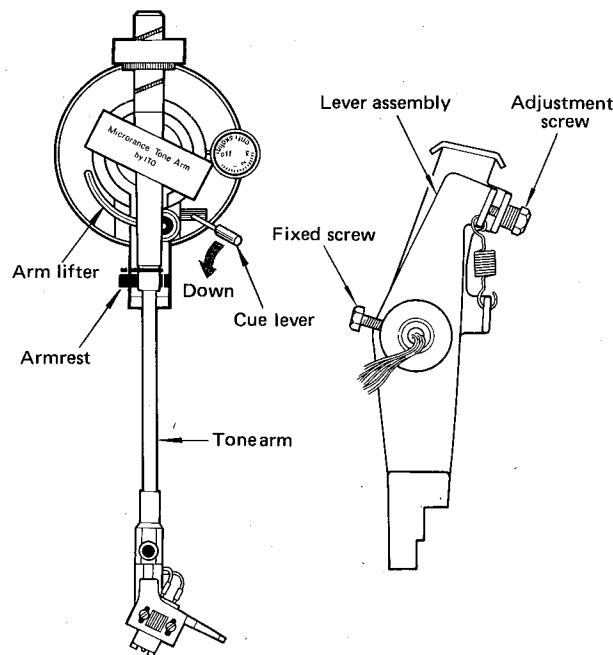

Fig. 1

■ **MOTOR R.P.M. ADJUSTMENT**

*Instrument

Stroboscope or Low range tachometer.

*Condition

1. Be sure that the drive belt between platter and motor pulley is hung.

2. Flip the cue lever forward to lift the tonearm up.

● **QUARTZ LOCK ADJUSTMENT**

1. Set the speed selector to 33 r.p.m., and set the quartz lock switch to ON.

2. Move tonearm horizontally as to be level with the platter, and rotate the platter.

3. Measure the motor speed by a stroboscope or low range tachometer.

4. Replace the motor pulley when the motor speed is not within the specified range.

5. Check the motor speed in the condition that the speed selector is set to 45 r.p.m.

● **QUARTZ LOCK OFF ADJUSTMENT**

1. Set the speed selector to 33 r.p.m. and set the quartz lock switch to OFF, then set the speed control knob at the center.

2. Adjust VR101 by turning the platter so that the motor speed rating is within 33-1/3 r.p.m. ± 0.05%.

3. Adjust VR102 in the condition that the speed selector is set to 45 r.p.m. so that the motor speed rating is within 45 r.p.m. ± 0.05%.

4. After all of these adjustments are over, make sure to confirm that each motor speed make a change more than ±3% with using speed control knob.

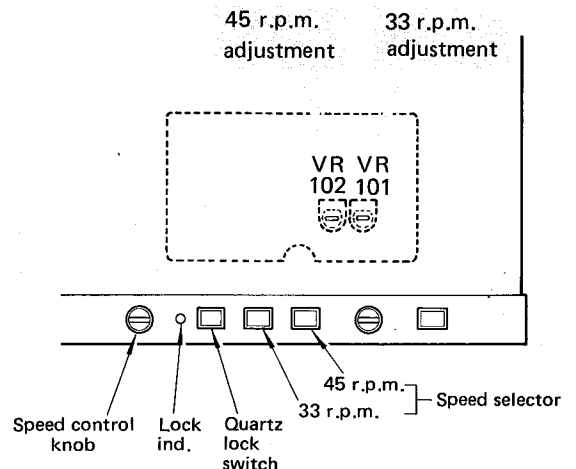
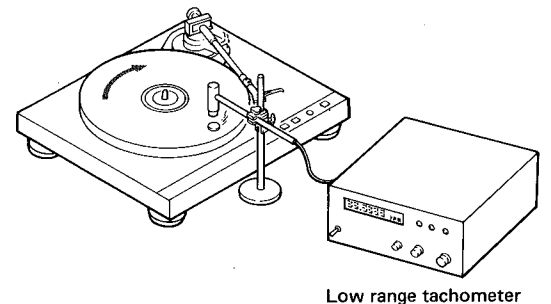

GENERAL UNIT EXPLODED VIEW

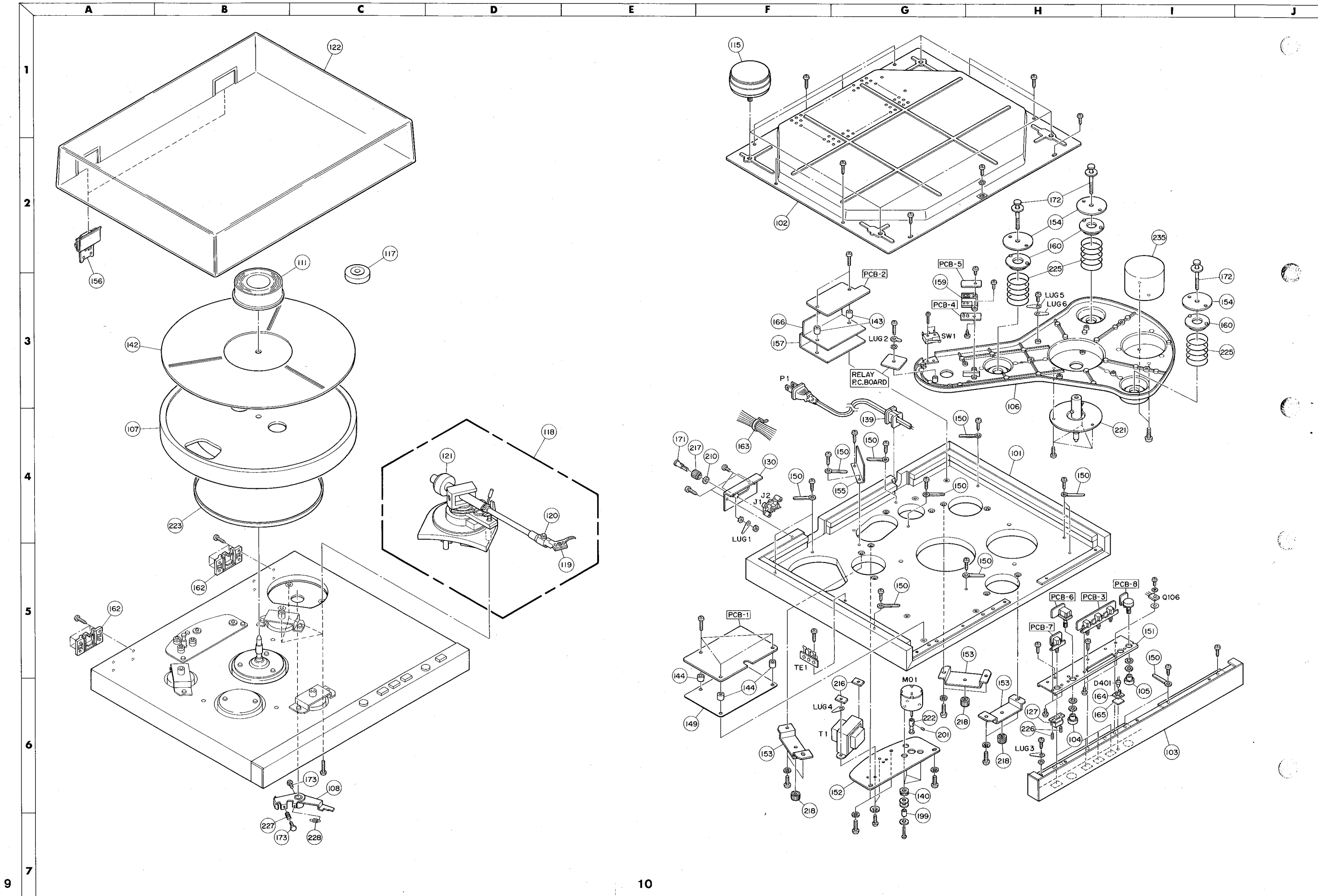

GENERAL UNIT EXPLODED VIEW

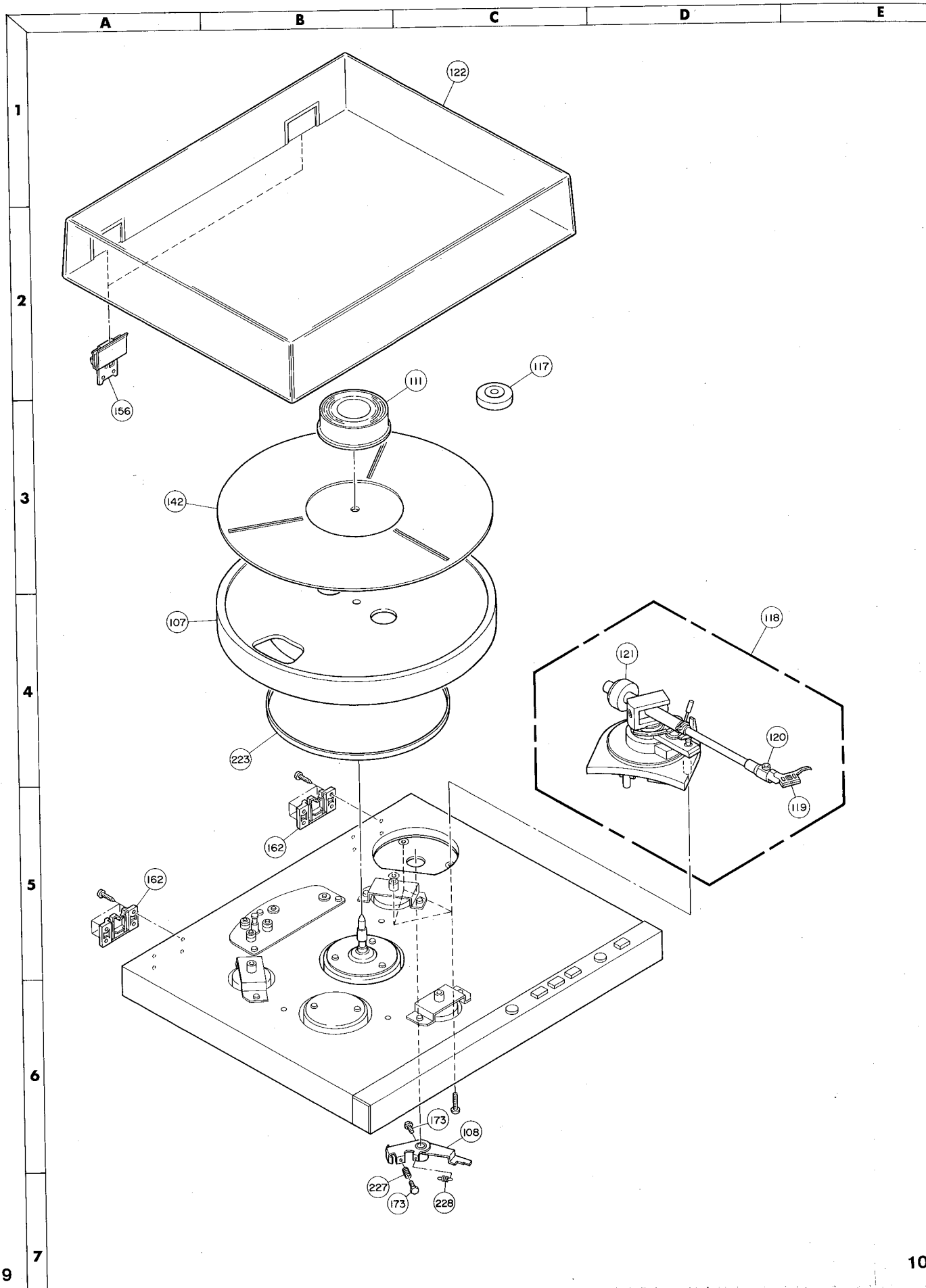

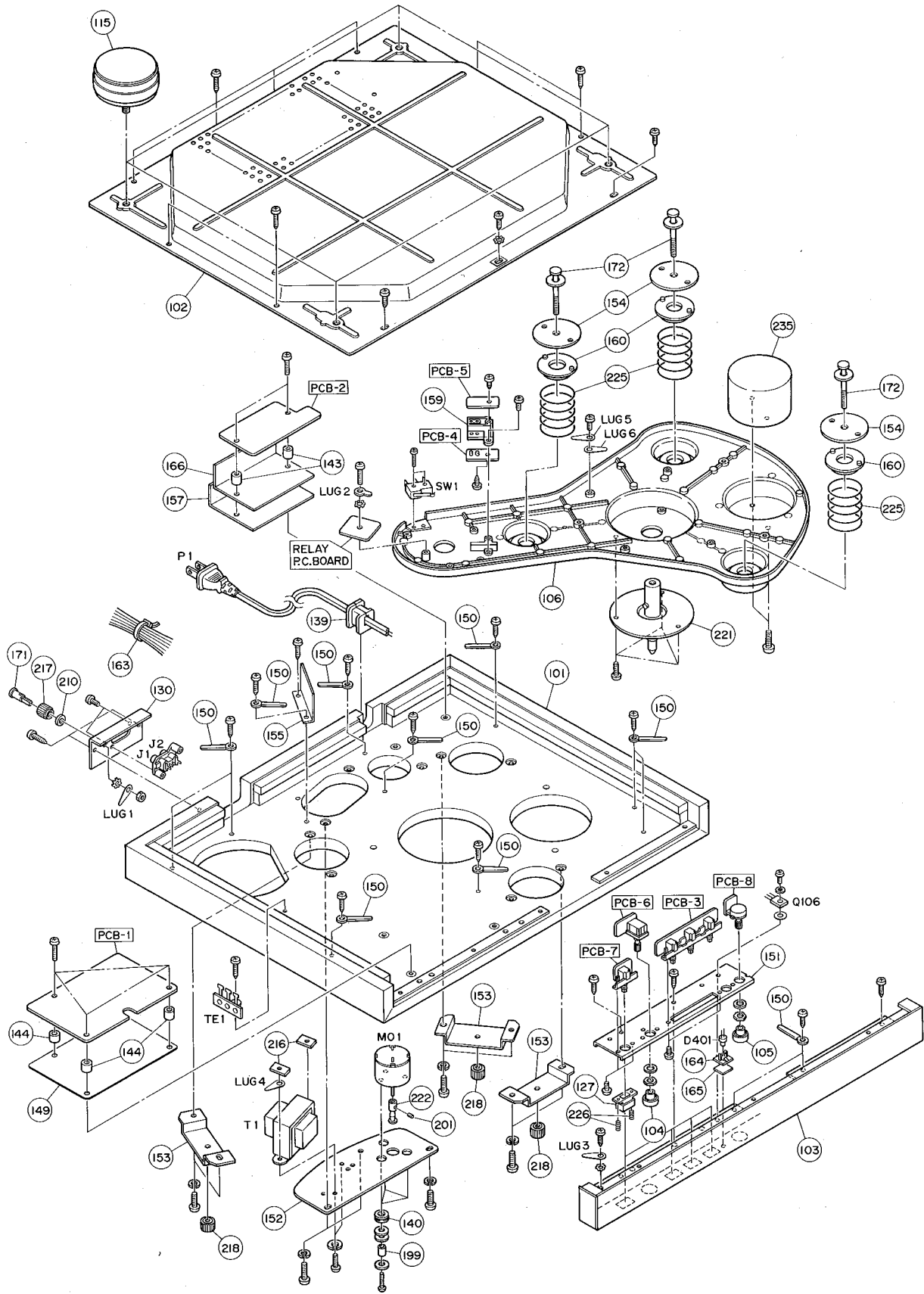

GENERAL UNIT PARTS LIST

Ref. No.	Part No.	Description
101	A415-T60	Cabinet Assembly
102	A424-T60	Cabinet Bottom Assembly
103	A443-T60	Front Panel Assembly
104	A634-T60A	Knob Assembly, Capacitance Trim
105	A634-T60B	Knob Assembly, Speed Control
106	B211-T60	Chassis Assembly
107	B665-T60	Platter Assembly
108	B672-T60	Lever Assembly
111	1161-00101	Disc Stabilizer with Stroboscope
115	1319-0147	Foot
117	1362-7007	E.P. Adaptor
118	1371-715	Pick-Up Assembly (Includes: SO701 Solenoid)
119	852366S	Headshell
120	852366A	Headshell Clamp
121	852366W	Counterweight
122	1472-01301	Dust Cover
127	1660-00201	Push Button, Quartz Lock, 33/45 Speed Selector
130	1724-02601	Indication Plate
139	2114-71264	Bushing, AC Line Cord
140	2114-71262	Bushing, Motor
142	2115-00101	Platter Mat
143	2132-7016	Spacer
144	2132-01405	Spacer
149	2216-7134	Shield Plate
150	2218-7001	Holding Bracket
151	2219-7863	Bracket
152	2219-7864	Bracket
153	2219-7865	Bracket
154	2219-7866	Bracket
155	2216-7136	Shield Plate
156	2221-7120	Hinge
157	2224-7074	Insulator
159	2240-7190	Holder
160	2240-7191	Holder
162	2240-7194	Holder
163	2240-7120	Holder
164	2240-7103	Holder
165	2132-7074	Spacer
166	2224-7076	Insulator
171	2310-7015	Special Screw (-)
172	2310-7020	Special Screw (-)
173	2316-300829	Hexagon Nut
199	2363-50168	Bushing
201	2371-200329	Setting Screw
210	2410-7005	Special Washer
216	2440-49	Special Nut
217	2440-7011	Special Nut
218	2440-7014	Special Nut
221	2601-7108	Shaft
222	2618-7002	Motor Pulley (*)
223	2642-02701	Drive Belt
225	2651-2101701	Spring
226	2651-2101702	Spring
227	2651-210116	Spring
228	2651-110331	Spring
235	2691-7001	Balancer
241	2618-7003	Motor Pulley (*)
242	2618-7004	Motor Pulley (*)

(*) There are three kind of motor pulley, these are reference No. 222, 241 and 242.

Replace the motor pulley accordance with QUARTZ LOCK ADJUSTMENT of MOTOR R.P.M. ADJUSTMENT on page 8.

ELECTRICAL PARTS LIST

Ref. No.	Part No.	Description
CHASSIS MISCELLANEOUS		
P1	4161-0487	AC Line Cord
T1	5584-701411	Power Transformer
MO1	4311-1A154	DC Motor
SW1	4431-A017128	Push Switch, Power
D401	5637-GL2PR1	L.E.D., GL2PR1, Quartz Lock Indicator
J1, 2	4482-7121	2-Pin Jack, Output
J110	4163-70965	Connector with Lead Wire, 7-Pin
J111	4163-70865	Connector with Lead Wire, 7-Pin
TE1	4212-7006	Terminal Strip
LUG1, 3, 4, 5, 6	4211-5005	Lug Terminal
LUG2	4211-9	Lug Terminal
PCB-1 MOTOR CONTROL P.C. BOARD		
RESISTORS		
R109	5174-683381	68k Ω , \pm 1%, 1/4W, Metal
R211	5176-331582	330 Ω , \pm 5%, 1/2W, Metal
CONTROLS		
VR101, 102	5101-1041926	100k Ω , Motor R.P.M. Adjustment
CAPACITORS		
C101, 107	5345-105-50	1 μ F, +75% -10%, 50V, Electrolytic
C102, 113, 203	5345-475-50	4.7 μ F, +75% -10%, 50V, Electrolytic
C104, 202	5345-476-10	47 μ F, +50% -10%, 10V, Electrolytic
C108, 201	5345-225-50	2.2 μ F, +75% -10%, 50V, Electrolytic
C109	5359-223571	0.022 μ F, \pm 5%, 50V, Polypropylene
C110	5359-104571	0.1 μ F, \pm 5%, 50V, Polypropylene
C111	5345-L224M50	0.22 μ F, \pm 20%, 50V, Electrolytic
C112, 117	5345-107-16	100 μ F, +50% -10%, 16V, Electrolytic
C115	5345-L474M50	0.47 μ F, \pm 20%, 50V, Electrolytic
C116	5345-226-25	22 μ F, +50% -10%, 25V, Electrolytic
INTEGRATED CIRCUIT		
IC101	5654-TC9142P	TC9142P
IC102	5652-CX-065B	CX-065B
TRANSISTORS		
Q101, 102, 103, 104, 105, 202, 204, 205	5613-2603(E)or(F)	2SC2603(E) or 2SC2603(F)
Q106	5614-669(C)or(D)	2SD669(C) or 2SD669(D)
Q201	5613-2603(F)or(G)	2SC2603(F) or 2SC2603(G)
Q203	5613-2236(Y)or(O)	2SC2236(Y) or 2SC2236(O)
DIODES		
D101	5635-RD5R1EB1	Zener, RD5.1EB1
D201	5631-1S2076	1S2076
D202	5632-1SR35-10	1SR35-100
MISCELLANEOUS		
X101	5691-02073620	Crystal, Osc.
SCR201	5661-03P05M	Silicon Controlled Rectifier
P110, 111	4443-074116	Connector, 7-Pin
J101	4443-040185	Connector, 4-Pin
J102, 103, 201, 202, 203	4443-030185	Connector, 3-Pin
J112	4163-70765	Connector with Lead Wire, 3-Pin

Ref. No.	Part No.	Description
PCB-2 POWER SUPPLY P.C. BOARD		
	RESISTOR	
R1	5176-221582	220 Ω , \pm 5%, 1/2W, Metal
	CAPACITORS	
C3	5345-475-50	4.7 μ F, +75% -10%, 50V, Electrolytic
C4, 5, 6	5345-227-25	220 μ F, +50% -10%, 25V, Electrolytic
C7, 8	5345-106-25	10 μ F, +50% -10%, 25V, Electrolytic
	TRANSISTOR	
Q1	5614-669(C)or(D)	2SD669(C) or 2SD669(D)
	DIODES	
D1	5685-1F	Bridge Silicon, S1WB10
D2	5632-1SR35-10	1SR35-100
D3	5635-RD11EB2	Zener, RD11EB2
	MISCELLANEOUS	
FU1	5732-75105	Fuse, 0.75A
	4472-7113	Fuse Holder (x2)
	2132-7048	Spacer, R1
PCB-3 CONTROL SWITCH P.C. BOARD		
SW401, 402, 403	4431-03067153	Push Switch, 33/45 Speed Selector, Quartz Lock
P101	4242-041007	Jumper Lead, 4-Wire
P102, 103, 201, 203	4242-031007	Jumper Lead, 3-Wire
PCB-4 LED P.C. BOARD		
D701, 702	5637-TLR108A	L.E.D., TLR-108A
PCB-5 PHOTO TRANSISTOR P.C. BOARD		
Q701, 702	5621-PT350F	PT350F
PCB-6 CAPACITANCE TRIM SELECTOR P.C. BOARD		
SW701	4411-203712	Rotary Switch, Capacitance Trim Selector
PCB-7 LIFT SWITCH P.C. BOARD		
SW404	4431-A027129	Push Switch, Lift
P202	4242-031007	Jumper Lead, 3-Wire
PCB-8 SPEED CONTROL P.C. BOARD		
VR401	5113-10371136	10k Ω B, Speed Control

PACKAGE

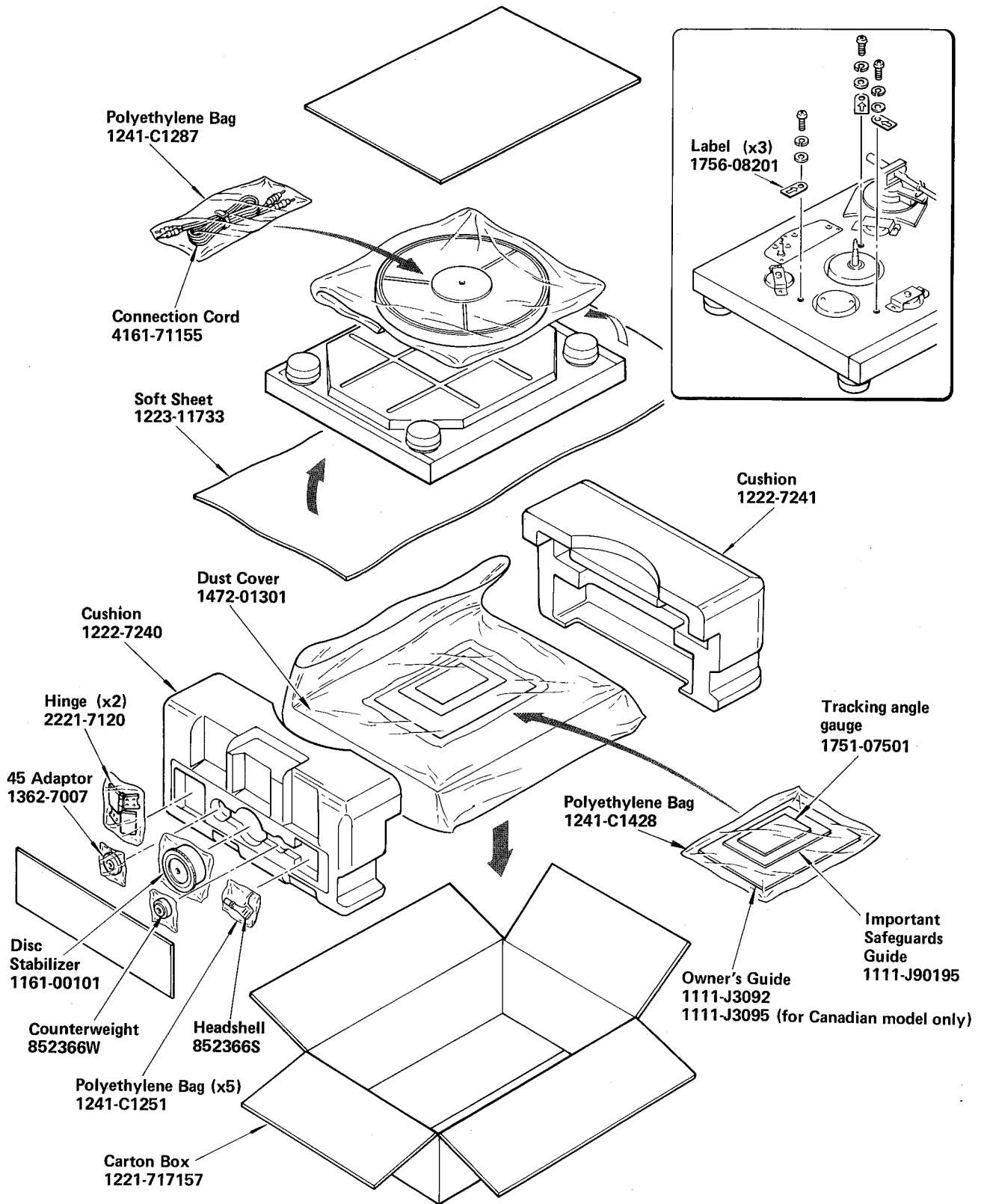

SCHEMATIC DIAGRAM

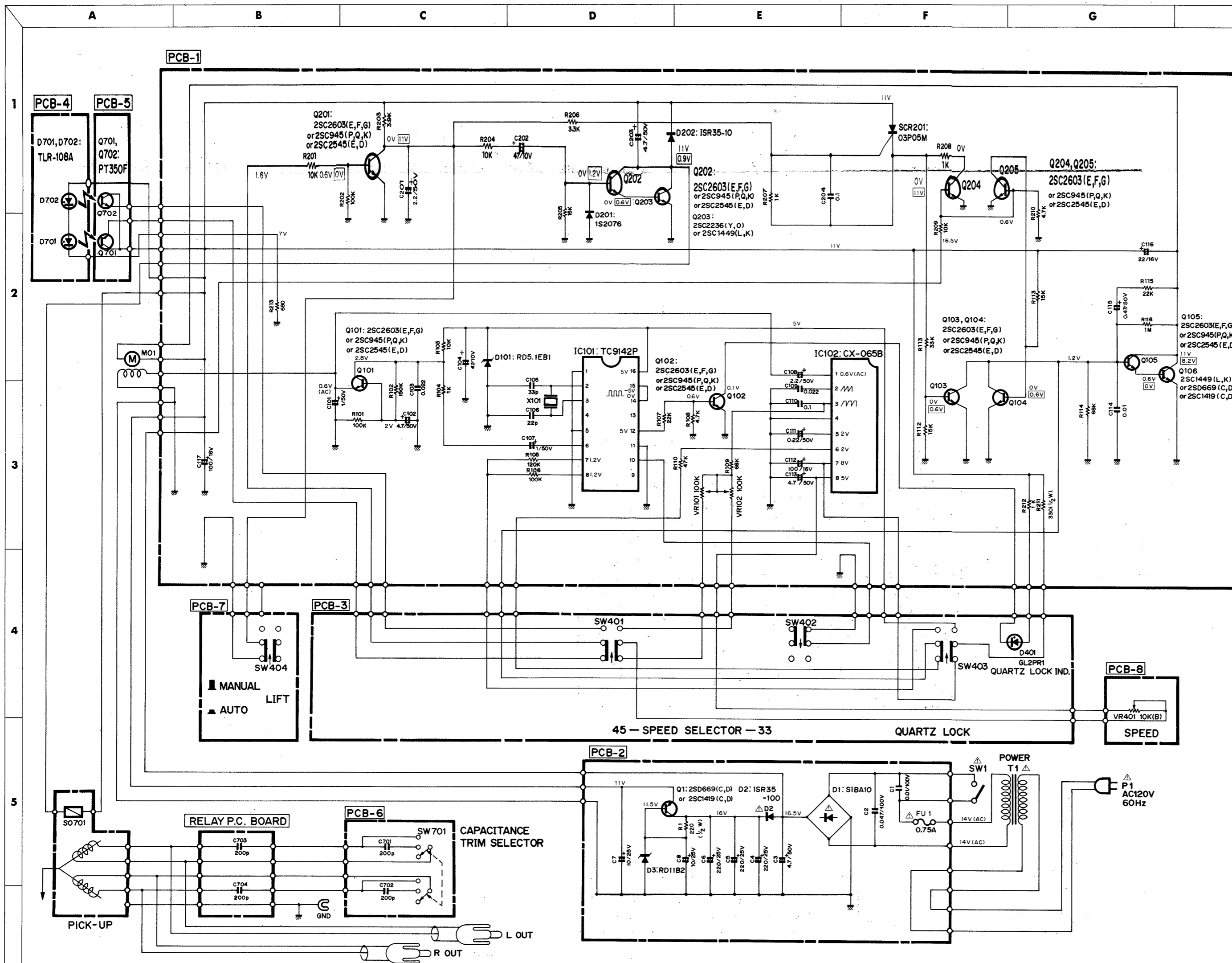

IC FUNCTIONAL BLOCK DIAGRAM

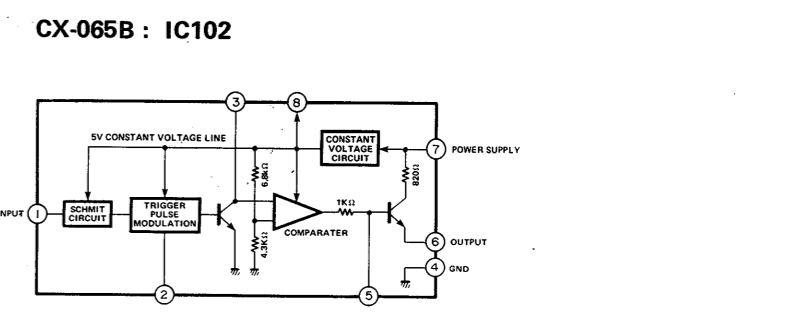
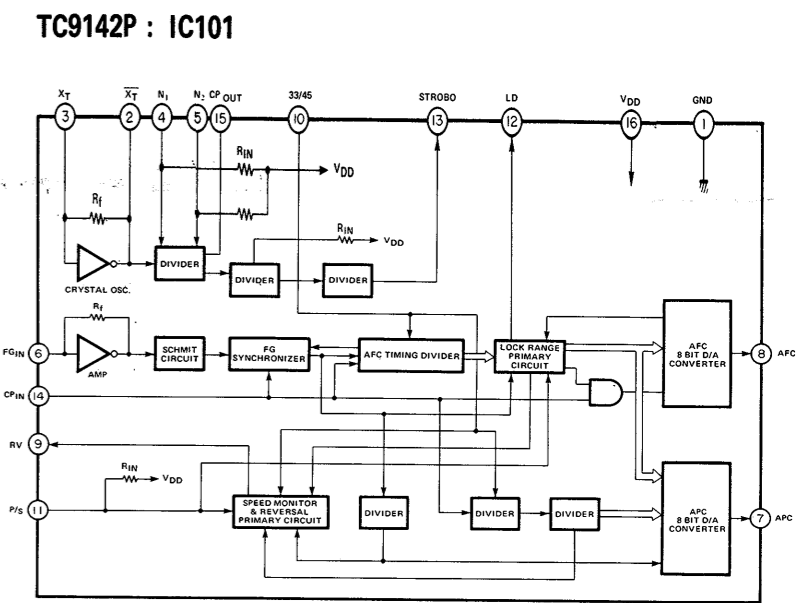

BLOCK DIAGRAM

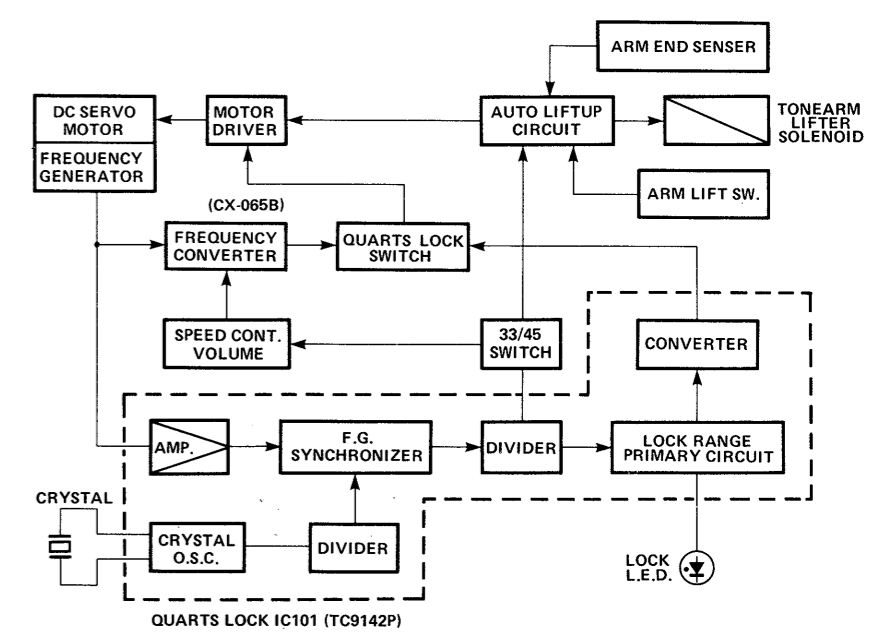

1. ALL RESISTANCES VALUES ARE IN Ω .
k Ω = 1000 Ω , M Ω = 1000 k Ω
2. THE WATTAGE OF RESISTORS IS 1/4W UNLESS OTHERWISE NOTED.
3. ALL CAPACITANCES VALUES ARE IN μ F UNLESS OTHERWISE NOTED. P = μ F
4. V: DC VOLTAGE EXCEPT (AC).
...V: AT NO SIGNAL []: WHEN THE DISC END POSITION IS DETECTED.
5. Δ SAFETY-REQUIREMENTS COMPONENTS IN ACCORDANCE WITH PRESENT SAFETY REGULATIONS. THESE COMPONENTS MUST ONLY BE REPLACED BY ORIGINAL PARTS.

SCHEMATIC DIAGRAM

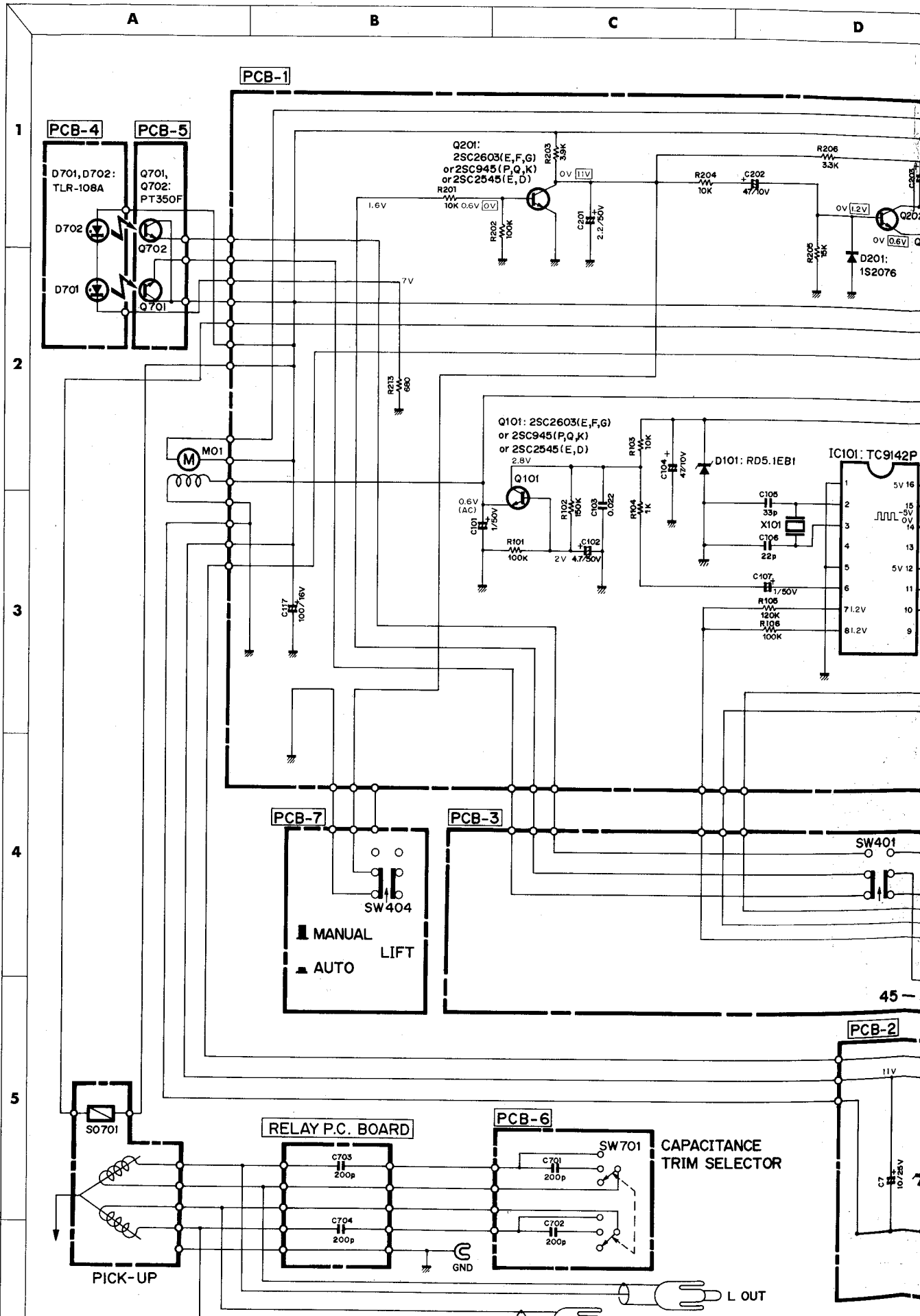

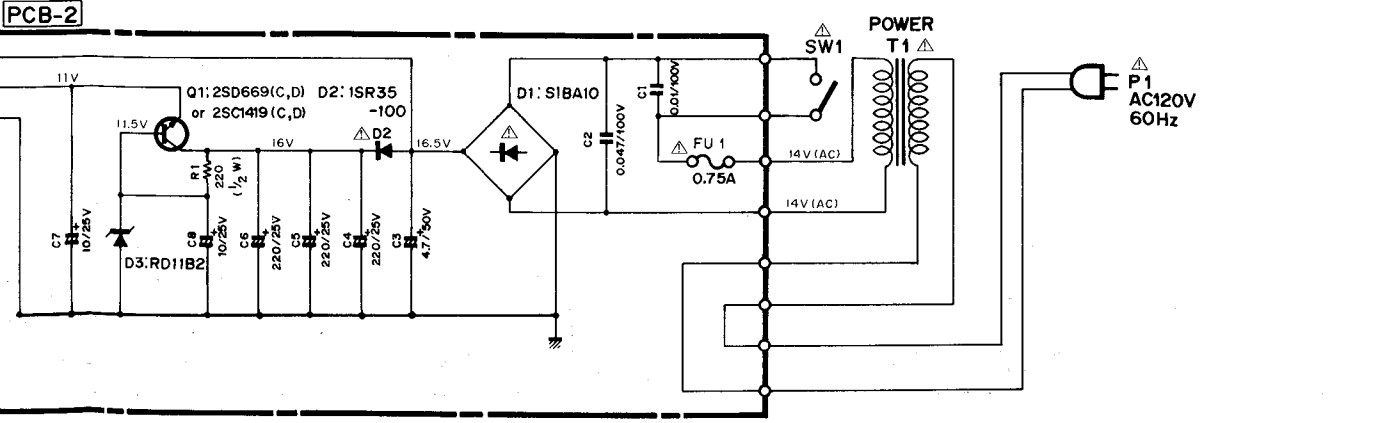
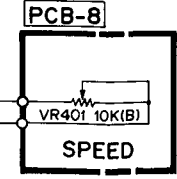
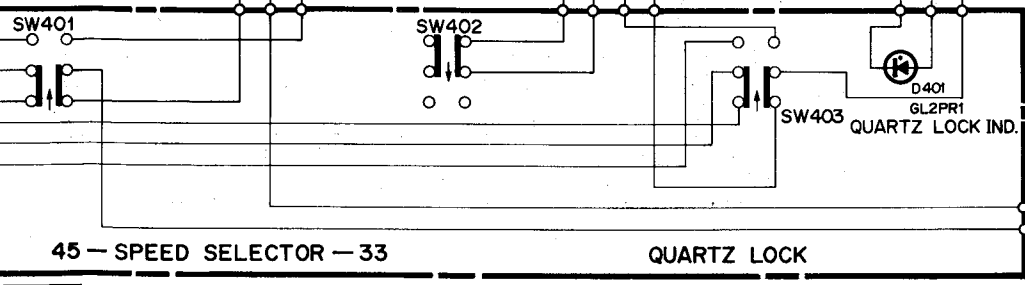
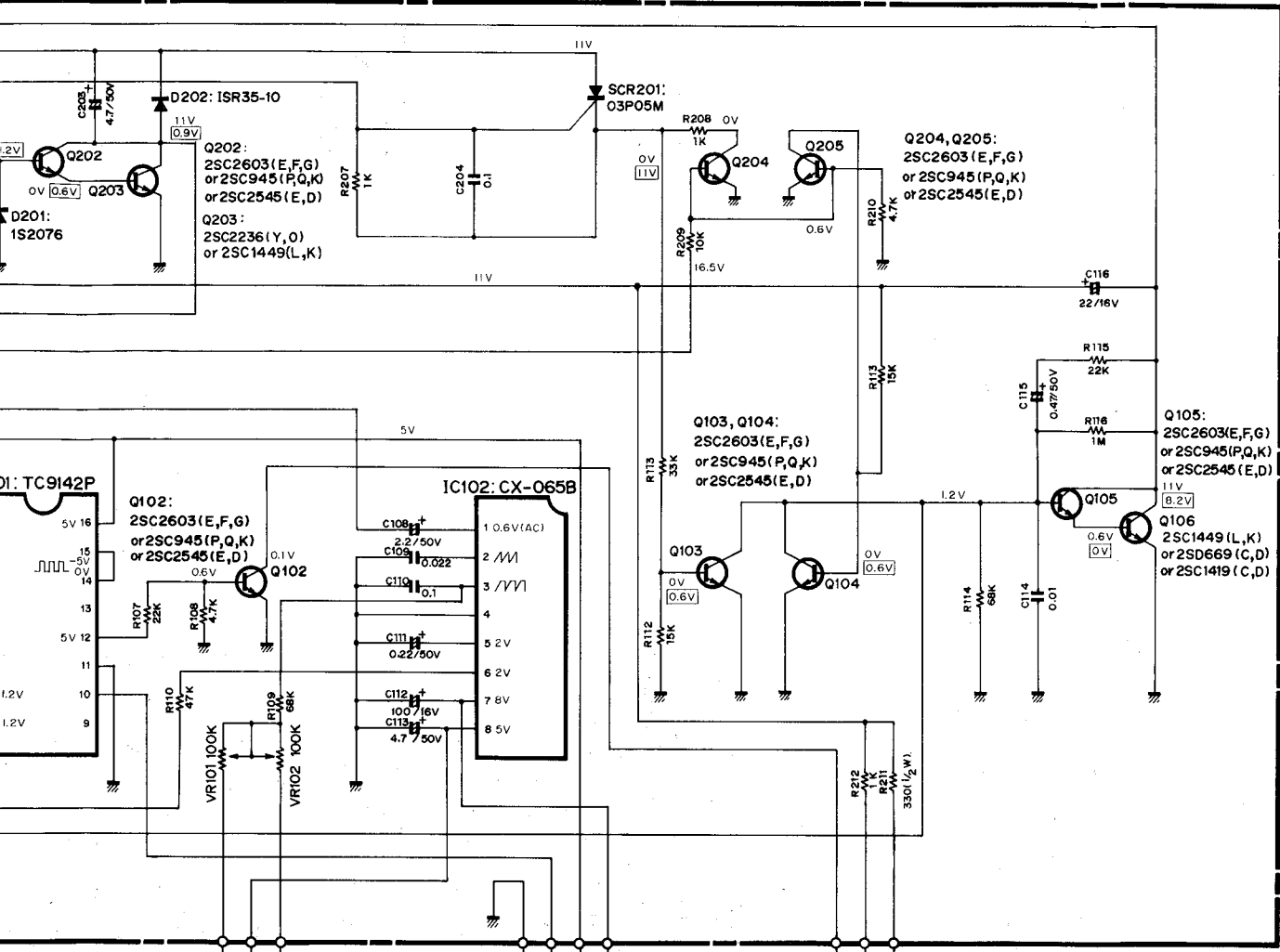

G

H

I

J

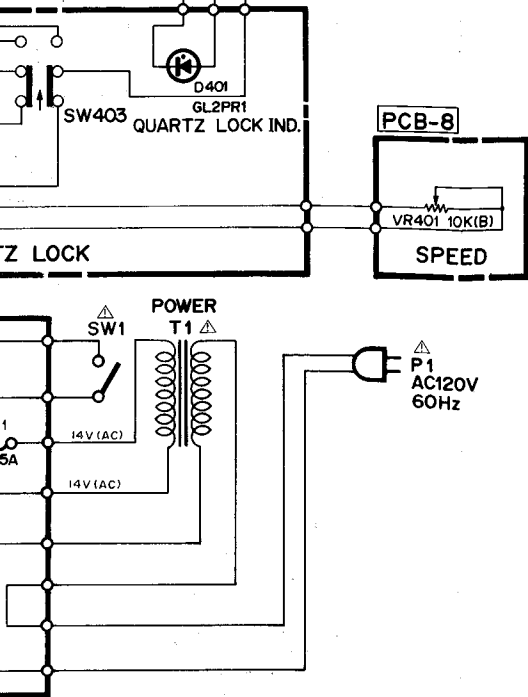
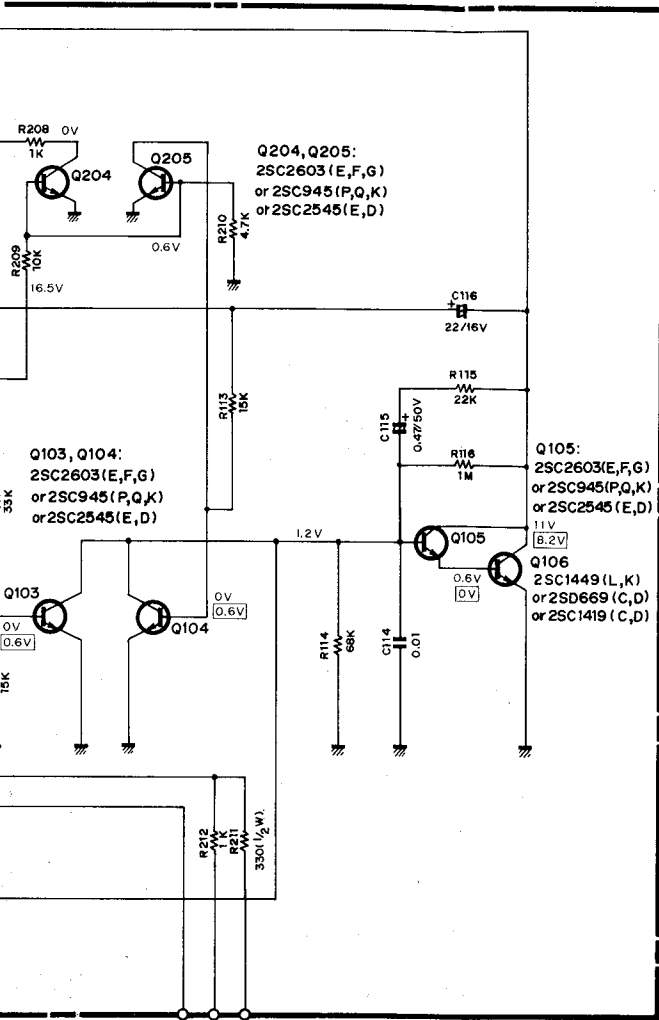

IC FUNCTIONAL BLOCK DIAGRAM

TC9142P : IC101

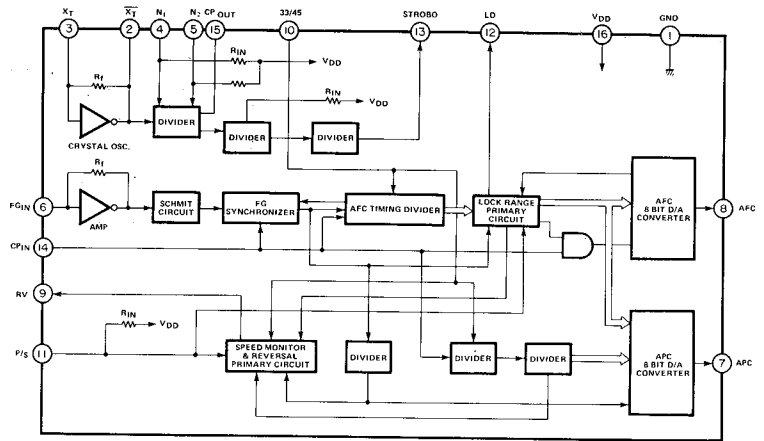

CX-065B : IC102

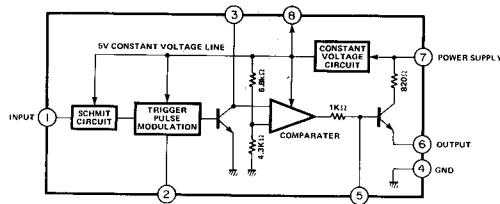

BLOCK DIAGRAM

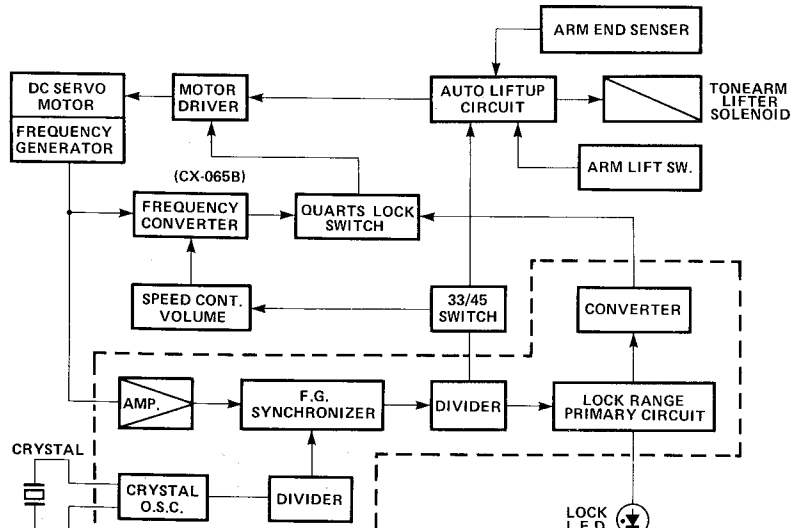

2
3
4
5
6
7

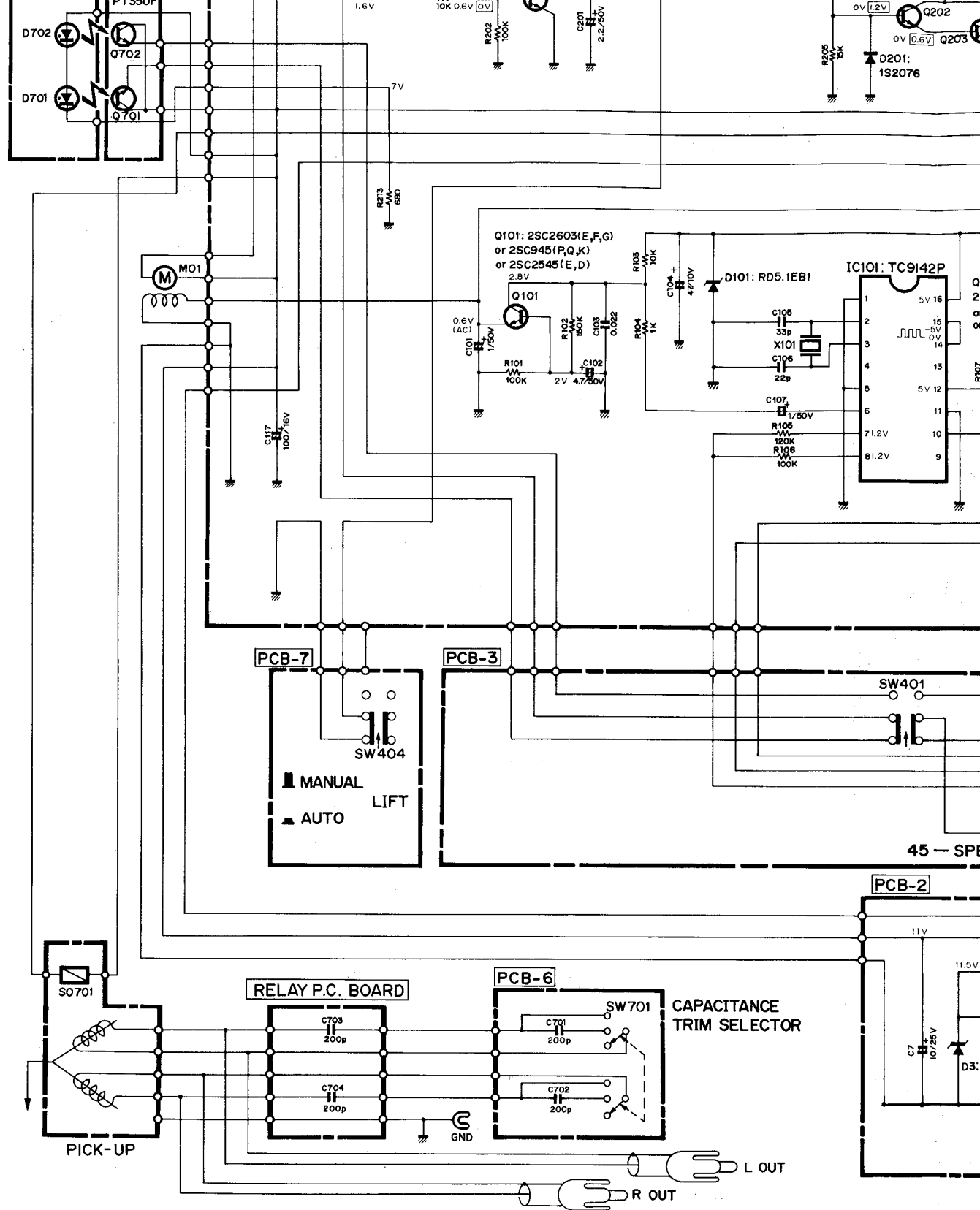

1. ALL RESISTANCES VALUES ARE IN Ω .
 $k\Omega = 1000\Omega$, $M\Omega = 1000 k\Omega$
2. THE WATTAGE OF RESISTORS IS 1/4W UNLESS OTHERWISE NOTED.
3. ALL CAPACITANCES VALUES ARE IN μF UNLESS OTHERWISE NOTED. $P = \mu\mu F$
4. V: DC VOLTAGE EXCEPT (AC).
 $\dots V$: AT NO SIGNAL $\dots V$: WHEN THE DISC END POSITION IS DETECTED.
5. \triangle SAFETY-REQUIREMENTS COMPONENTS IN ACCORDANCE WITH PRESENT SAFETY REGULATIONS. THESE COMPONENTS MUST ONLY BE REPLACED BY ORIGINAL PARTS.

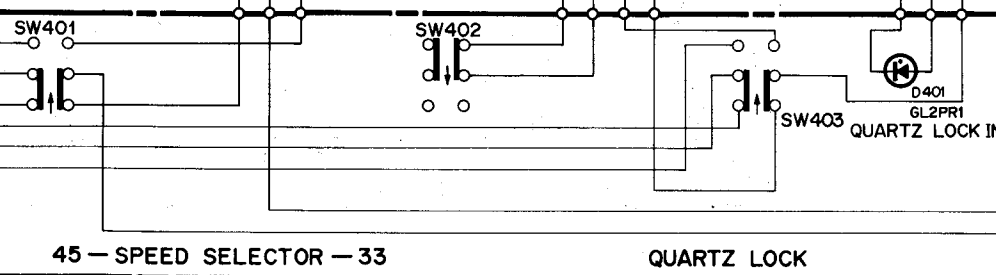
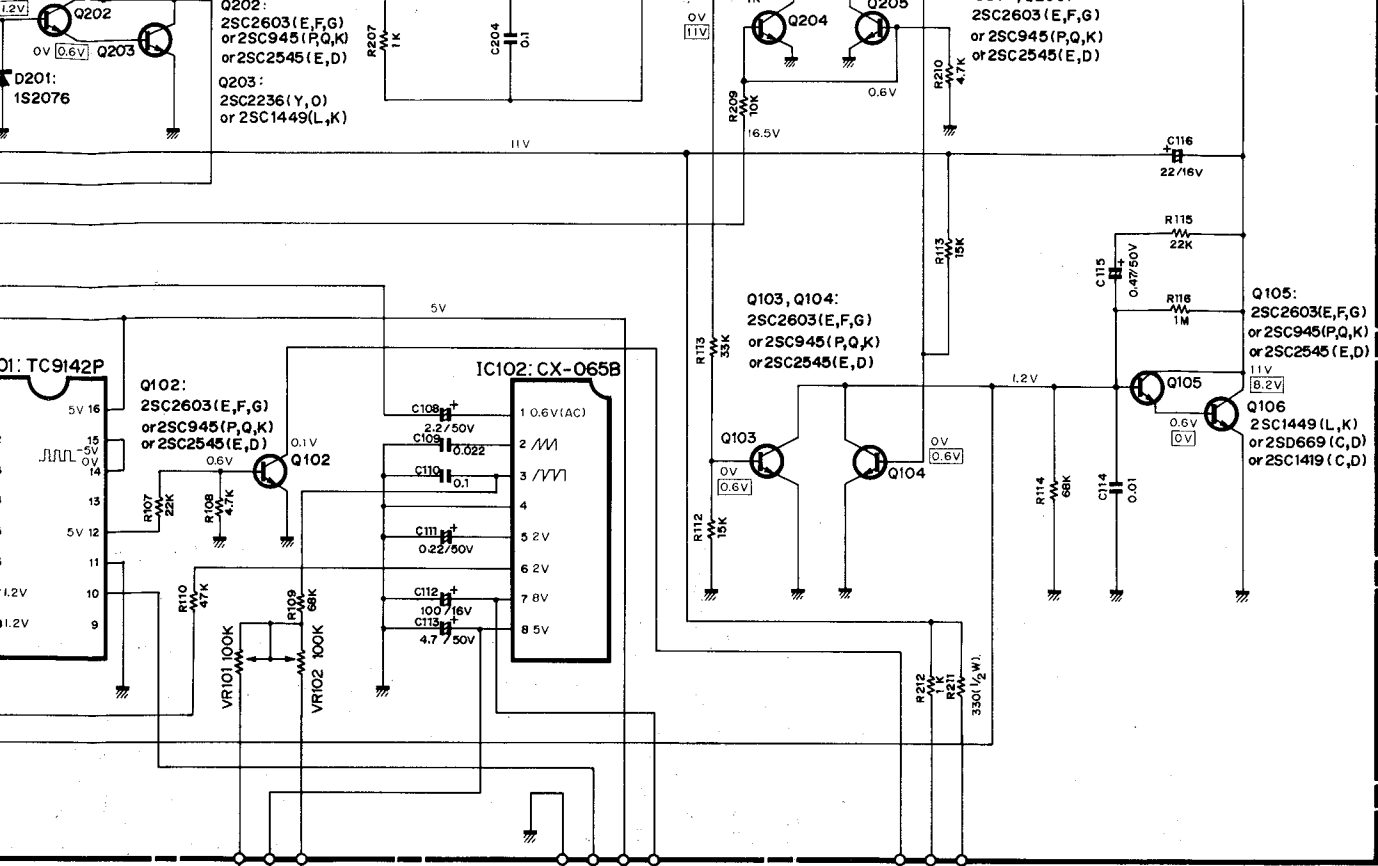

45 - SPEED SELECTOR - 33

QUARTZ LOCK

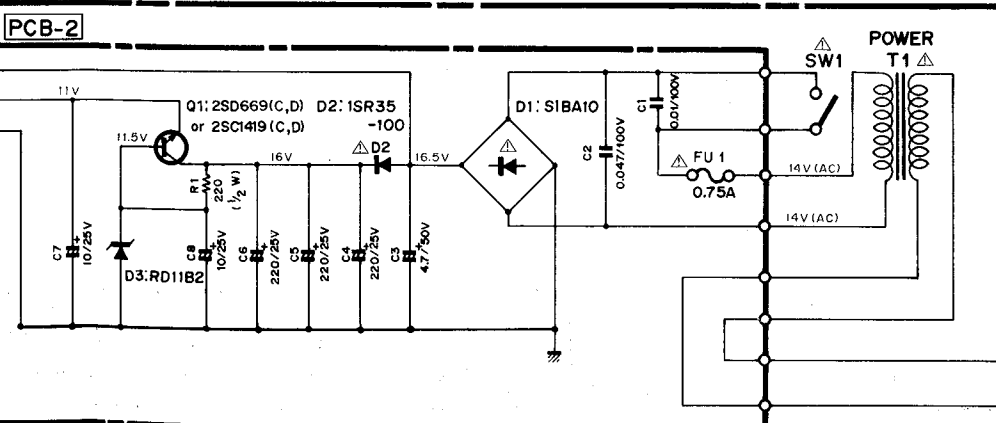
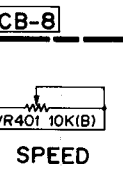

BLOCK

DC SERVO MOTOR

FREQUENCY GENERATOR

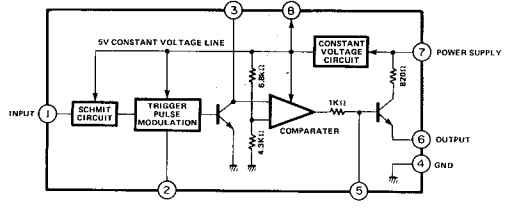
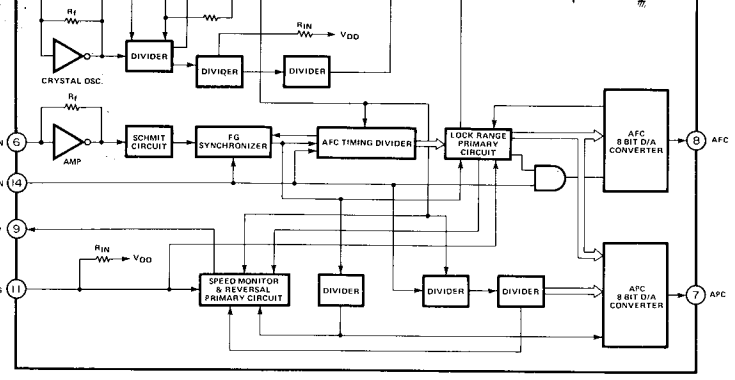
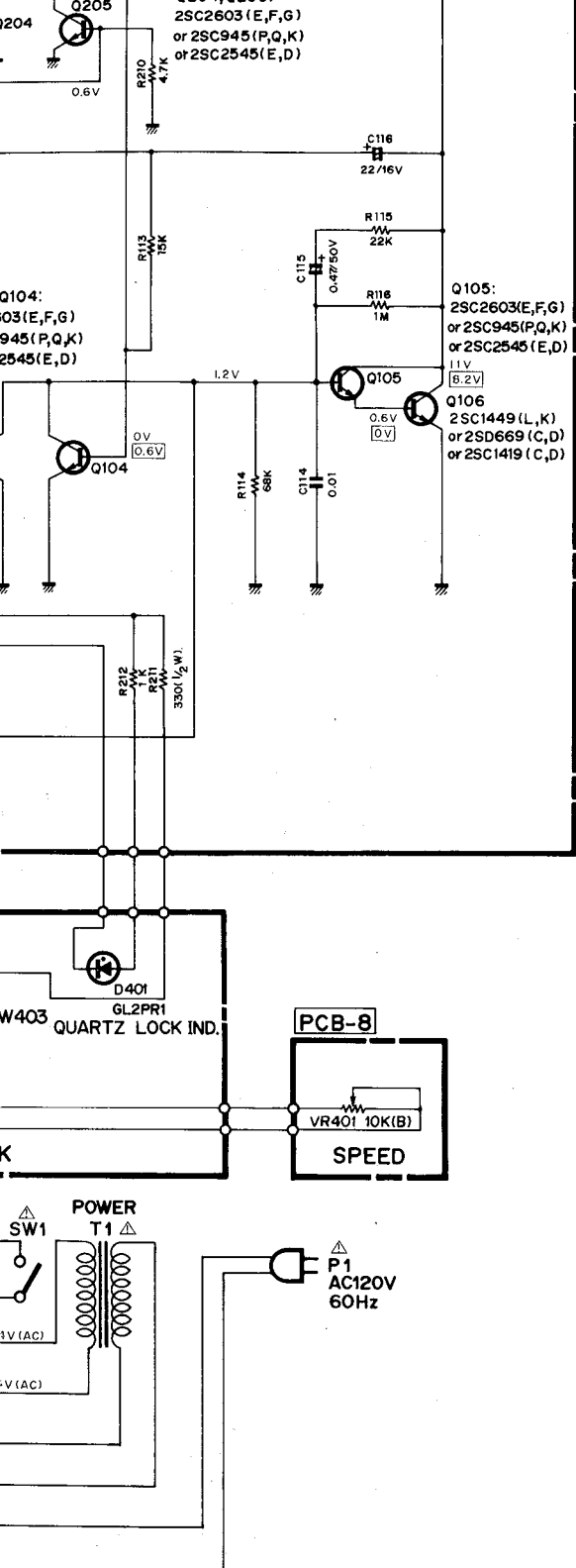

BLOCK DIAGRAM

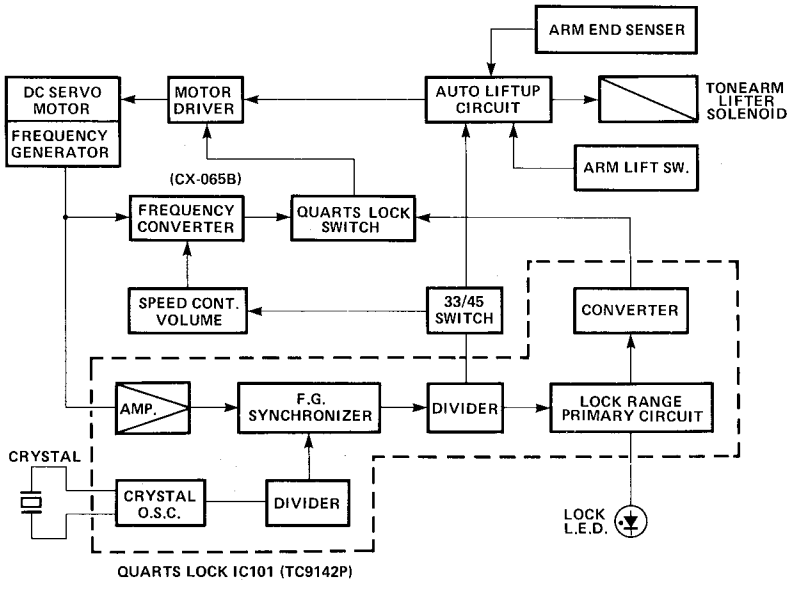

WIRING DIAGRAM

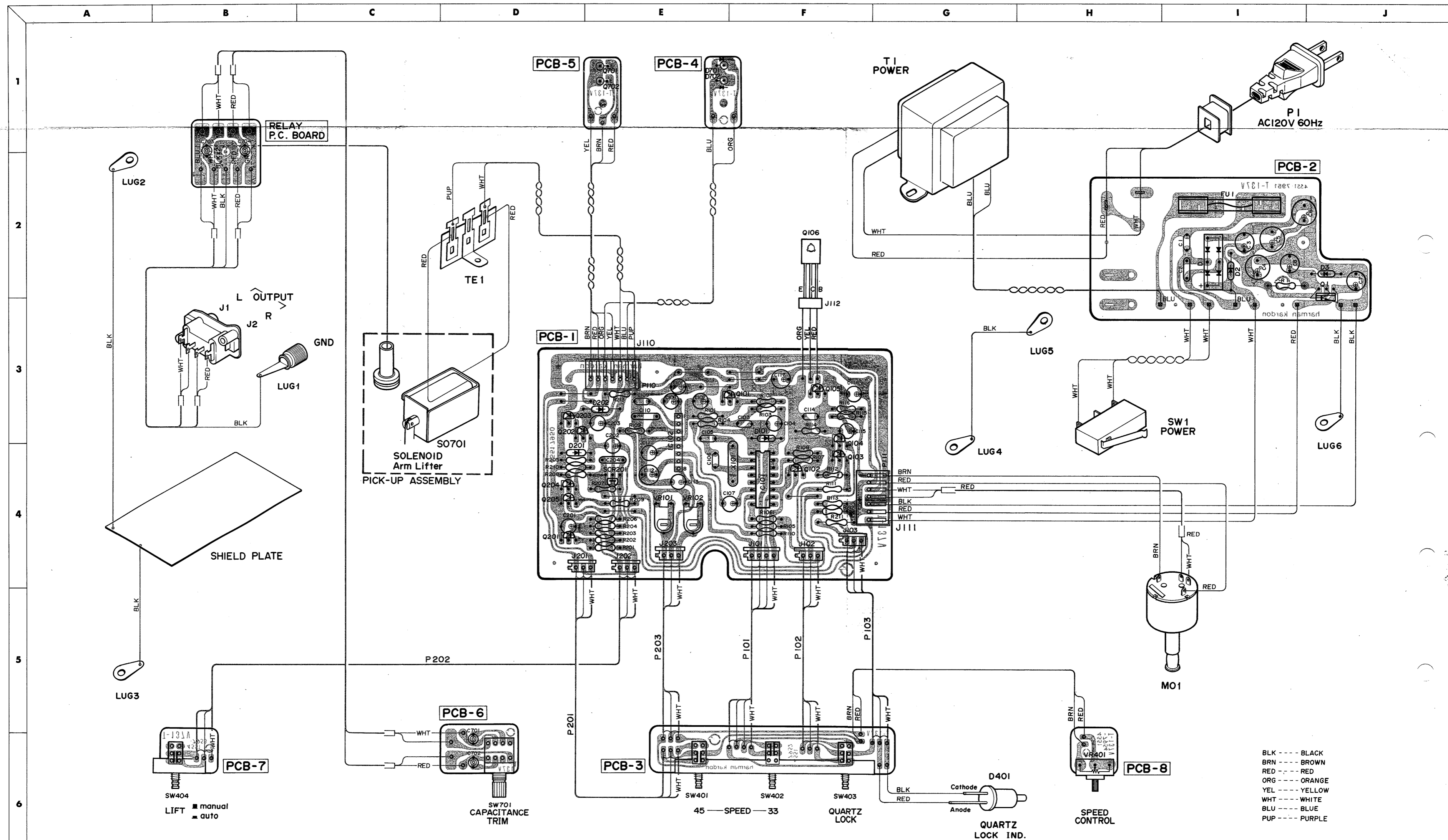

- BLK --- BLACK
- BRN --- BROWN
- RED --- RED
- ORG --- ORANGE
- YEL --- YELLOW
- WHT --- WHITE
- BLU --- BLUE
- PUP --- PURPLE

PIN CONNECTION DIAGRAM OF TRANSISTORS, DIODES AND ICs.

IC101: TC9142P	IC102: CX065B	Q1, 106: 2SD669 (C) or (D)	Q101 ~ 105, 202, 204, 205: 2SC2603 (E) or (F) Q201: 2SC2603(F) or (G)	Q203: 2SC2236 (Y) or (O)	Q701, 702: PT350F	D1: SIRBA(1F)	D2: 10D-1 or 1SR35-10 D202: 1SR35-10 D3: HZ11C2 or RD11EB2 D101: HZ5C1 or RD5R1EB1 D201: 1S2076	D401: GL2PR1	D701, 702: TLR-108A

WIRING DIAGRAM

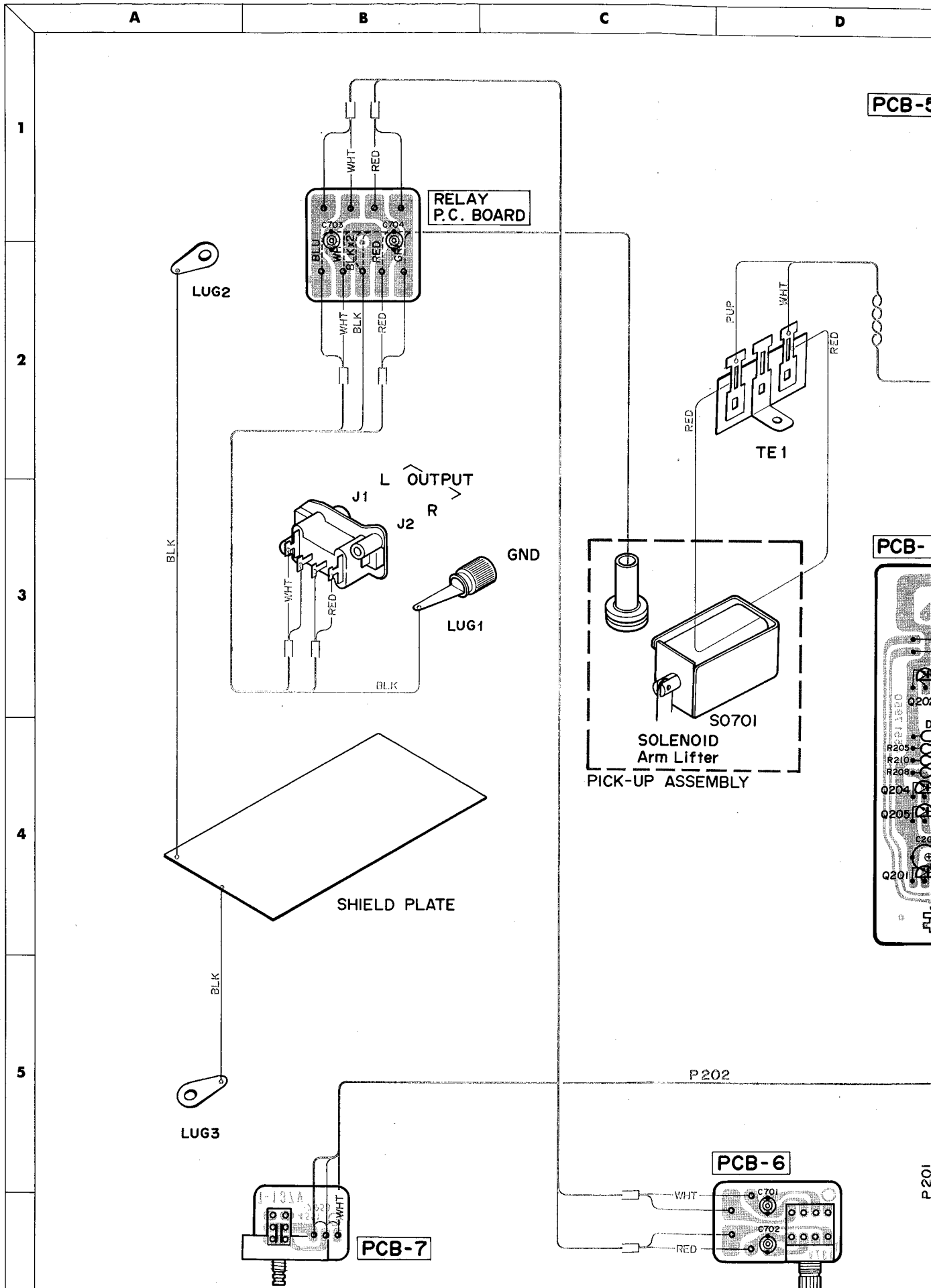

D

E

F

G

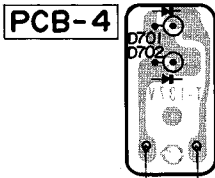
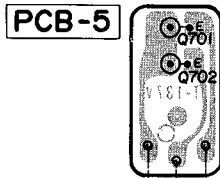

T1
POWER

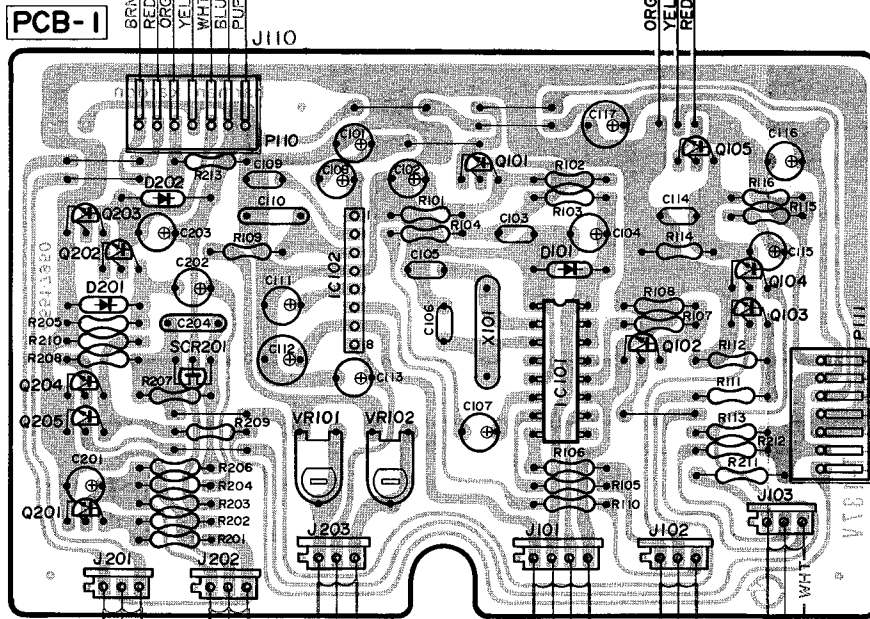
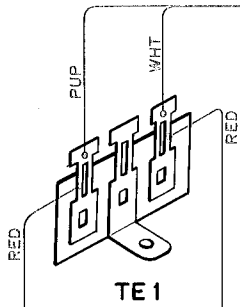
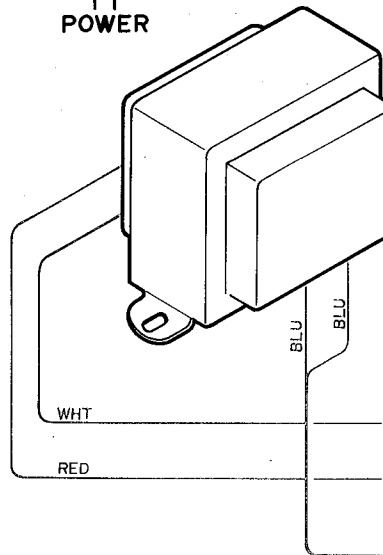

BLK

LUG 4

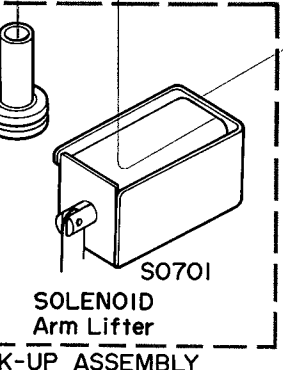
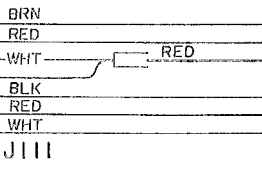

P 202

P 201

PCB-3

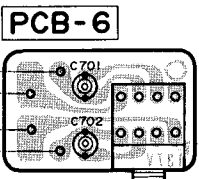

D40

Cathode

G

H

I

J

T1
POWER

P1
AC120V 60Hz

PCB-2

J112

LUG5

SW1
POWER

LUG6

J111

MO1

P103

PCB-8

- BLK ---- BLACK
- BRN ---- BROWN
- RED ---- RED
- ORG ---- ORANGE
- YEL ---- YELLOW

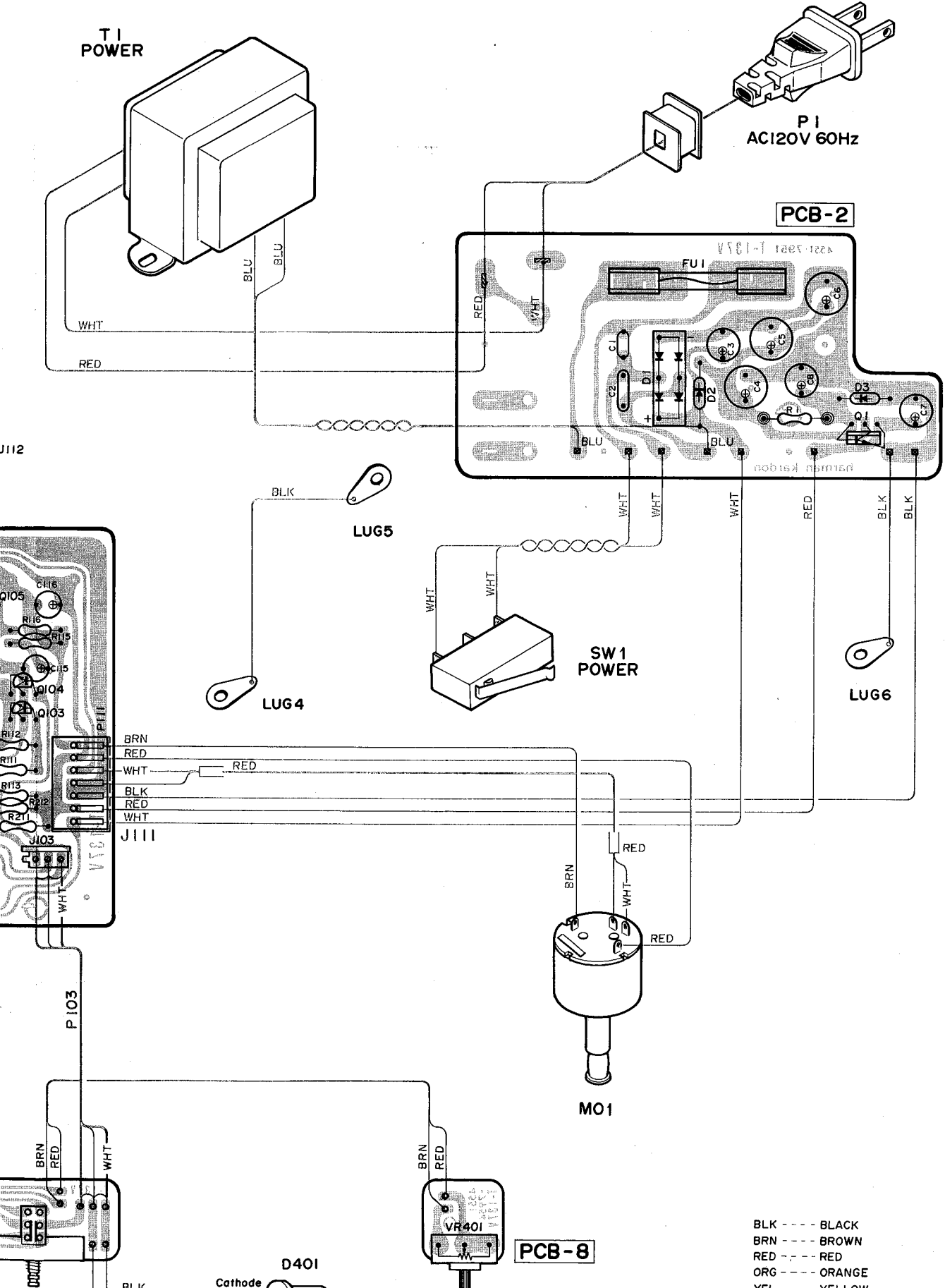

2

3

4

5

6

7

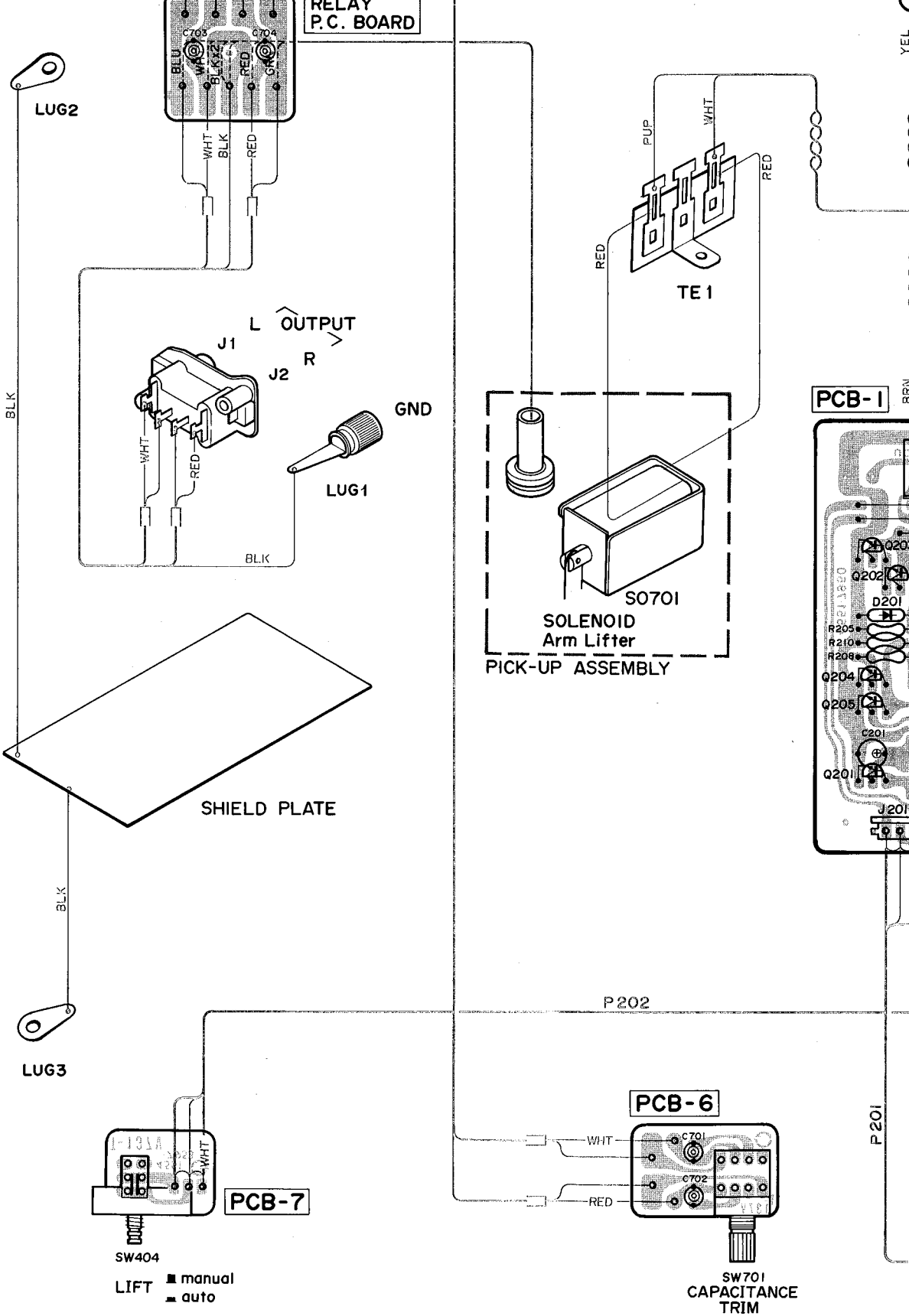

PIN CONNECTION DIAGRAM OF TRANSISTORS, DIODES AND ICs.

<p>IC101: TC9142P</p>	<p>IC102: CX065B</p>	<p>Q1, 106: 2SD669 (C) or (D)</p>	<p>Q101 ~ 105, 202, 204, 205: 2SC2603 (E) or (F) Q201: 2SC2603(F) or (G)</p>	<p>Q203: 2SC2236 (Y) or (O)</p>	<p>Q701, 702: PT350F</p>	<p>D1: SIRBA(1F)</p>	<p>D2: D20 D3: D10 D20</p>
-----------------------	----------------------	-----------------------------------	--	---------------------------------	--------------------------	----------------------	------------------------------------

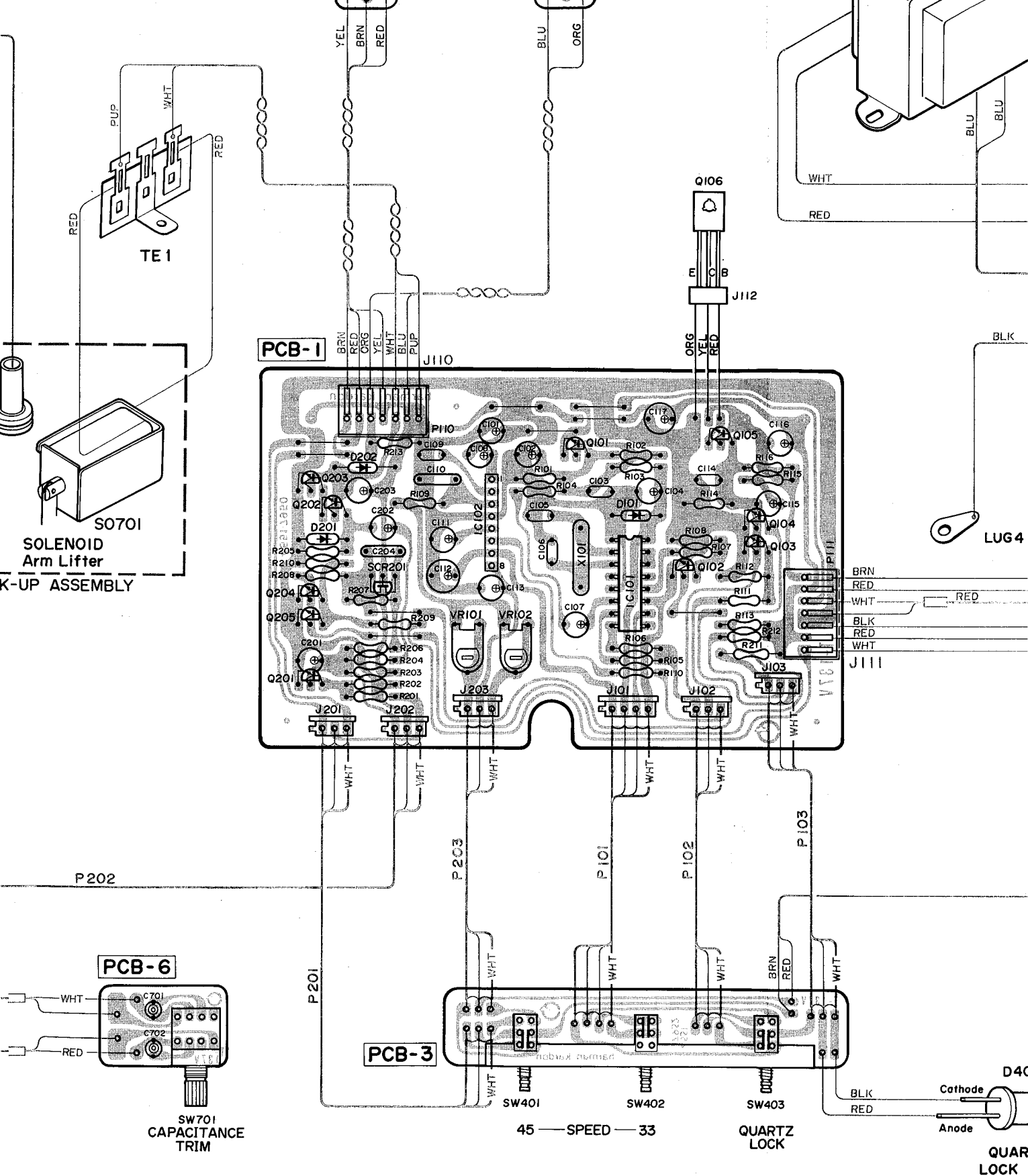

<p>203: 2SC2236 (Y) or (O)</p>	<p>Q701, 702: PT350F</p>	<p>D1: SIRBA(1F)</p>	<p>D2: 10D-1 or 1SR35-10 D202: 1SR35-10 D3: HZ11C2 or RD11EB2 D101: HZ5C1 or RD5R1EB1 D201: 1S2076</p>	<p>D401: GL2PR1</p>	<p>D701, 702: TLR-108A</p>
--------------------------------	--------------------------	----------------------	--	---------------------	----------------------------

PCB-2

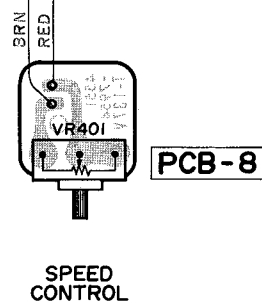
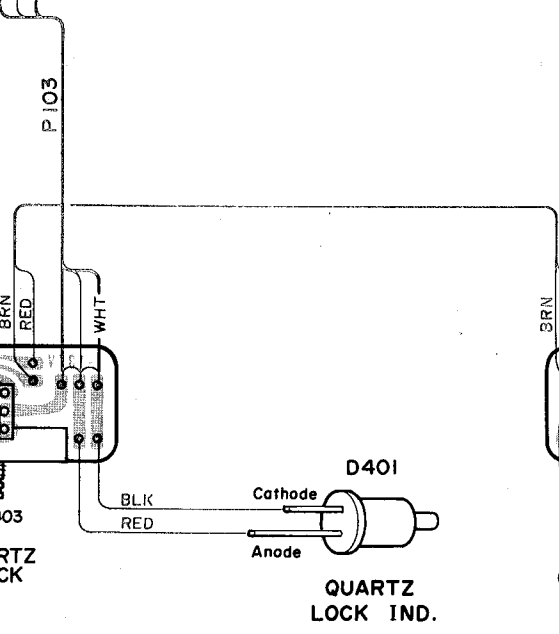
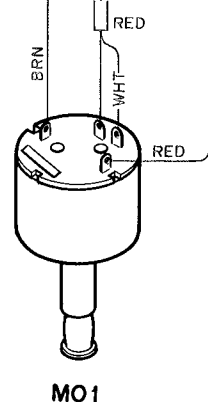
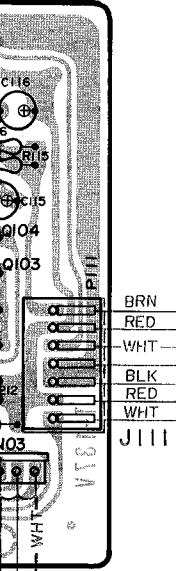
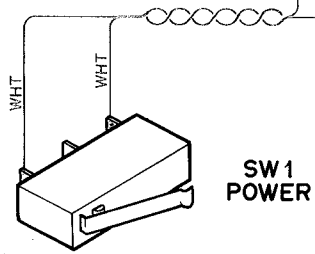
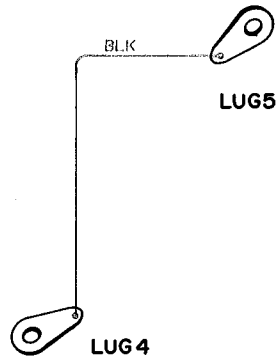
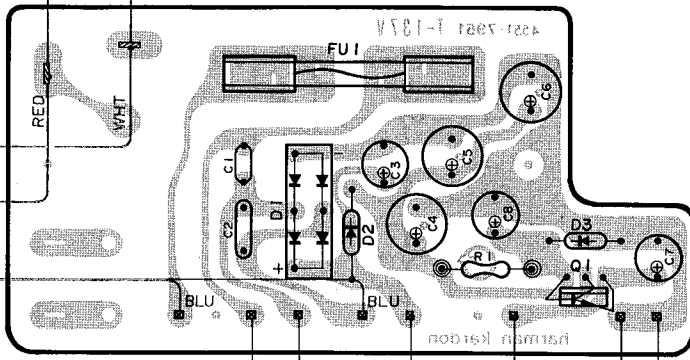

- BLK ---- BLACK
- BRN ---- BROWN
- RED ---- RED
- ORG ---- ORANGE
- YEL ---- YELLOW
- WHT ---- WHITE
- BLU ---- BLUE
- PUP ---- PURPLE