

The Harman Kardon Model T65C

Manual No. 78A

FLOATING SUSPENSION AUTO LIFT TURNTABLE

Technical Manual

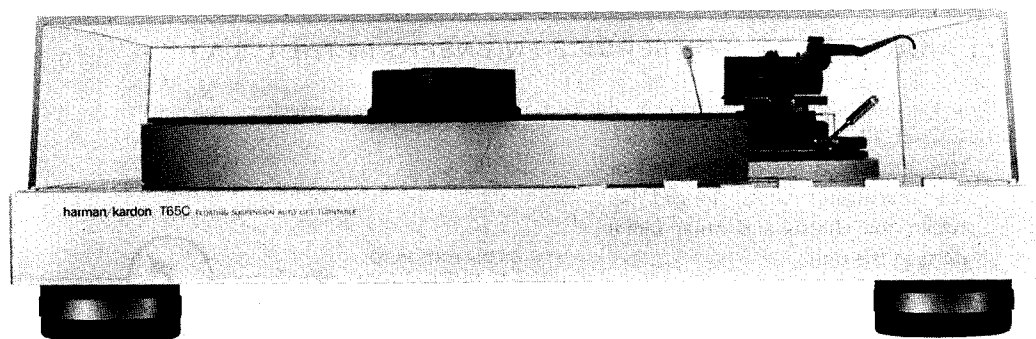

harman/kardon

240 CROSSWAYS PARK WEST, WOODBURY, N.Y. 11797
1112-H15278A2 P-08849 1850 PRINTED IN JAPAN

T65C

SPECIFICATIONS

Wow & Flutter (WRMS)	0.025%
Rumble (DIN-B WTD)	-70dB, DIN 45544 record reference
Pitch Adjustable Range	±4%
Tonearm	
Effective Tonearm Mass	9.5g (plus the mass of the cartridge used)
Stylus Overhang	18 mm
Offset Angle	25.5°
Effective Length	216 mm
Tracking Error	±2 degrees
Phono Capacitance	70/170/270pF
Tracking Force	0 ~ 3 grams

Acceptable Weight of Cartridge	4.5 ~ 13 g
Dimensions (W x H x D)	17-1/2"x5-3/4"x15-1/4" (443x145x384 mm)
Weight	17 lbs. 10 oz. (8 kg)
Power Supply	
U.S.A. and Canada models	AC120V, 60Hz
General model	AC110-120V/220-240V 50/60Hz
Power Consumption	
U.S.A. and Canada models	8W
General model	10W

Specifications and components subject to change without notice.
Overall performance will be maintained or improved.

LEAKAGE TEST (FOR SERVICE ENGINEERS IN THE U.S.A.)

Before returning the unit to the user, perform the following safety checks:

1. Inspect all lead dress to make certain that leads are not pinched or that hardware is not lodged between the chassis and other metal parts in the unit.
2. Be sure that any protective devices such as nonmetallic control knobs, insulating fishpapers, cabinet backs, adjustment and compartment covers or shields, isolation resistor-capacity networks, mechanical insulators, etc. which were removed for servicing are properly reinstalled.
3. Be sure that no shock hazard exists; check for leakage current using Simpson Model 229 Leakage Tester, standard equipment item No. 21641, RCA Model WT540A or use alternate method as follows:

Plug the power cord directly into a 120-volt AC receptacle (do not use an Isolation Transformer for this test). Using two clip leads, connect a 1500 Ohm, 10-watt resistor paralleled by a 0.15 μ F capacitor, in series with all exposed metal cabinet parts and a known earth ground, such as a water pipe or conduit. Use a VTVM or VOM with 1000 Ohms per volt, or higher, sensitivity to measure the AC voltage drop across the resistor. (See Diagram.) Move the resistor connection to each exposed metal part having a return path to the chassis (antenna, metal, cabinet, screw heads, knobs and control shafts, escutcheon, etc.) and measure the AC voltage drop across the resistor. (This test should be performed with the power switch in both the On and Off positions.)

A reading of 0.35 volt RMS or more is excessive and indicates a potential shock hazard which must be corrected before returning the unit to the owner.

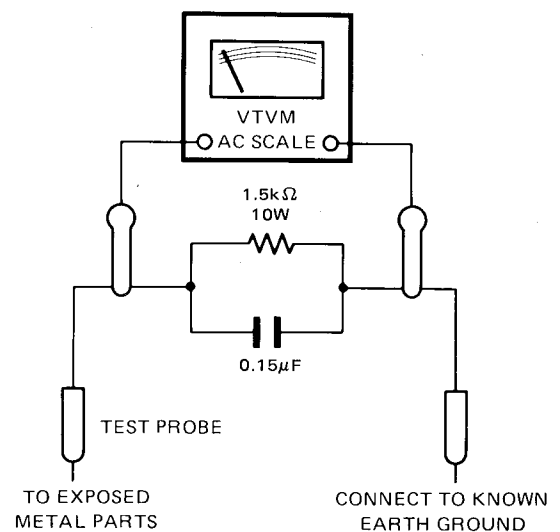
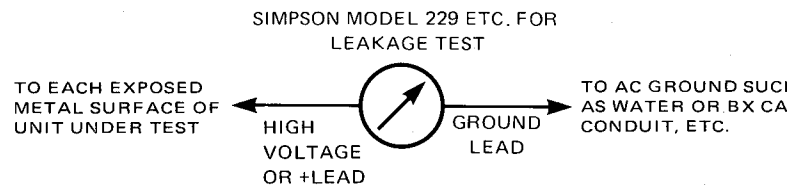

DISASSEMBLY PROCEDURES (REFER TO PAGES 6, 7 AND 13)

NOTE: Before disassembling the unit, remove the platter, platter mat, counterweight and headshell with cartridge, and securely tie the arm to the armrest with string, etc. Then gently turn the unit upside down and place it on cloths, etc. piled up on both sides to protect the arm and cabinet from damage.

1 CABINET BOTTOM ASSEMBLY (102) REMOVAL

Remove a screw (A) and 10 screws (B) and remove the Cabinet Bottom Assembly (102).

* Toothed washer is attached to the screw (A).

2 FRONT PANEL ASSEMBLY (103) REMOVAL

1. Remove the Cabinet Bottom Assembly (102). (Refer to step 1.)
2. Remove 6 screws (C) and remove the Bracket (184) with PCB-3 and PCB-7 by pulling the Front Panel Assembly (103) slightly forward then remove the Front Panel Assembly.

3 PICK-UP ASSEMBLY (129) REMOVAL

1. Remove the Cabinet Bottom Assembly (102). (Refer to step 1.)
2. Unsolder the lead wires connected to the Solenoid (L1) on Pick-up Assembly (129) from Photo Transistor P.C.Board (PCB-6), and unsolder the lead wires connected to the Capacitance Trim Selector P.C. Board (PCB-4).
3. Loosen screw (D) and remove the Lever Assembly (107).
4. Remove 3 screws (E) and remove the Pick-up Assembly (129) with the Capacitance Trim Selector P.C.Board (PCB-4).
5. Pull out the Cap. Trim Knob (139/140).
6. Remove the Nut (F). (Fit a narrow tipped tool such as radio pliers into the groove of the nut and turn it counterclockwise.)

7. Separate Capacitance Trim Selector P.C.Board (PCB-4) from the Pick-up Assembly (129).

4 CHASSIS ASSEMBLY (105) REMOVAL

1. Remove the Pick-up Assembly (129). (Refer to step 3.)
2. Remove 4 screws (G) and remove the LED P.C.Board (PCB-5), Photo Transistor P.C.Board (PCB-6) and Microswitch (SW1).
3. Remove LUG2 from the Center Spindle Assembly (273). Then remove 3 screws (H) and remove the Center Spindle Assembly from the Chassis Assembly (105).
4. Remove 2 screws (I) and remove the Balancer (297) from the Chassis Assembly (105).
5. Unsolder the lead wire connected to the LUG1 on the Chassis Assembly (105) and remove a screw (J) mounting LUG1 and remove it.
6. Remove 3 nuts (K) and remove the Chassis Assembly (105) by turning the Special Screws (L) clockwise.

5 MOTOR (MO1) REMOVAL

1. Remove the Cabinet Bottom Assembly (102). (Refer to step 1.)
2. Unsolder the lead wires connected to the Motor Assembly (MO1), and disconnect the connector (LCN3) from Motor Assembly (MO1).
3. Loosen screw (M) and remove the Motor Pulley (275).
4. Remove 3 screws (N) and remove the Motor Assembly (MO1).

6 POWER TRANSFORMER (T1) REMOVAL

1. Remove the Cabinet Bottom Assembly (102). (Refer to step 1.)
2. Unsolder the lead wires connected to Power Supply P.C.Board (PCB-2) from Power Transformer (T1).
3. Remove 2 screws (O) and remove the Power Transformer (T1).

POWER CORD REPLACEMENT (FOR SERVICE ENGINEERS OTHER THAN NORTH AMERICA)

In order to prevent fire or shock hazard when replacing the power cord, follow the procedure below to replace the parts with the standard supply parts.

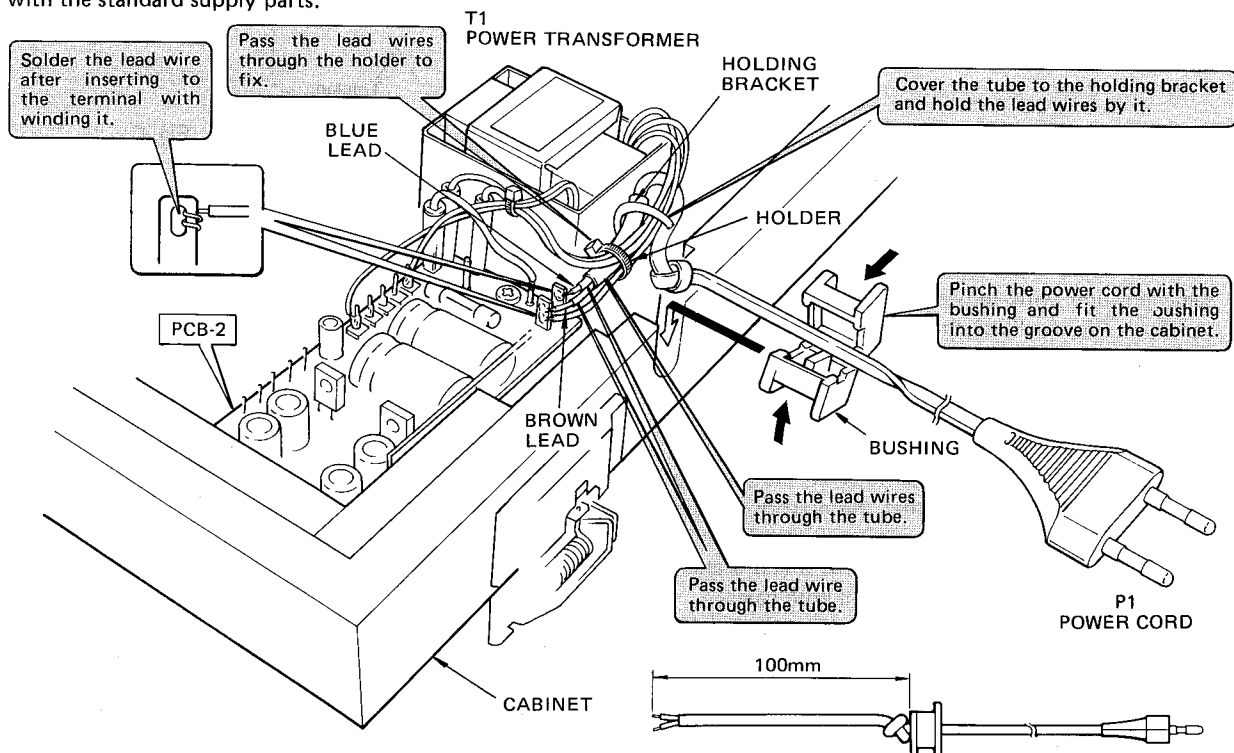

CARTRIDGE REPLACEMENT INSTRUCTION

Only use cartridges in the headshell provided. Be sure to use a cartridge weighting 4.5 to 13 grams.

1. Release the tonearm clamp and lift the tonearm gently.
2. Loosen the headshell clamp and gently pull the headshell with cartridge. (See Fig. A.)
3. Disconnect the 4 leads from cartridge pins using a tweezers and, then loosen the retaining screws so that the cartridge comes out.
4. Replace the leads onto the new cartridge. Refer to Fig. B for correct placement of leads.
5. When all leads are connected properly, install cartridge to the headshell as shown in the Fig. B.
6. Temporarily tighten the retaining screw to hold the cartridge.
7. Insert the headshell with the cartridge fully into the tonearm and then tighten the headshell clamp.

When cartridge is replaced with new one, it is necessary to adjust the Overhang and Tracking angle.

● Overhang Adjustment

1. Place the accessory tracking angle gauge on the center spindle and raise the flap.
2. Be sure to remove the stylus guard when adjusting the overhang.
3. Move the tonearm directly over the center spindle. Line up the raised flap on the gauge with the center spindle and the tonearm base. Gently move the cartridge backward or forward in the headshell so that the stylus-tip lines up with the corner of the flap.

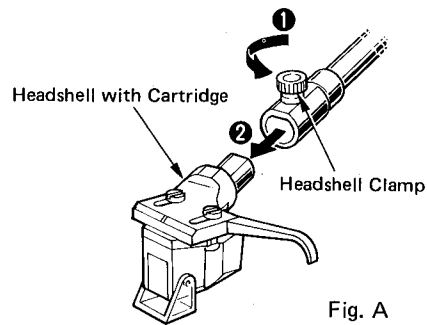

Fig. A

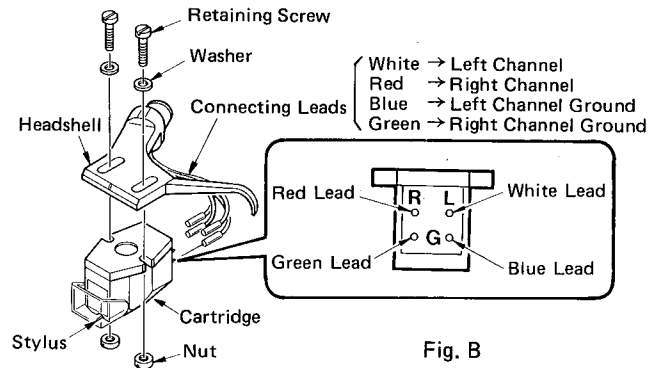

Fig. B

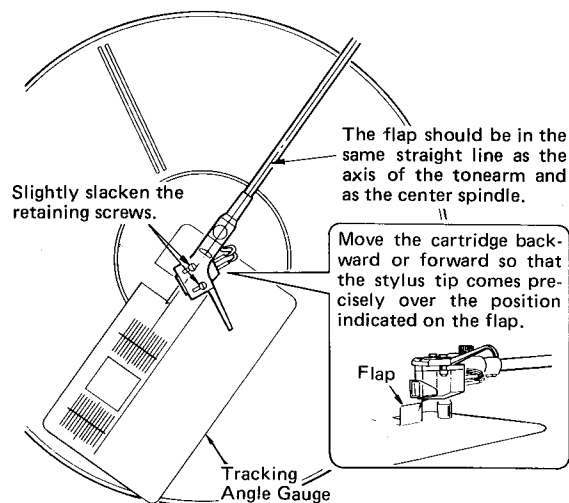

Fig. C

● Tracking Angle Adjustment

1. Check to be sure that the overhang adjustment has been completed.
2. Now move the tracking angle gauge until it is in the same position with respect to the tonearm as that shown in Fig. D. Place the stylus over the tracking angle setting point while keeping stylus guard attached.
3. Without changing the stylus position, turn the cartridge so that its front edge is parallel with the lines on the gauge.
4. Now move the gauge so that it is in the position shown in Fig. E and check that the cartridge is still parallel with the parallel lines as it was in step 3 above. If it is not parallel, then repeat steps 3 and 4 alternately until the cartridge is parallel in both cases.
5. When the above adjustment is completed, then fully tighten the screws that attach the cartridge to the headshell.

Adjust the cartridge so that the front of the cartridge is parallel with the parallel lines.

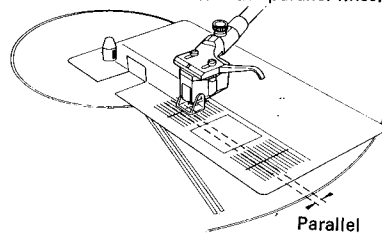

Fig. D

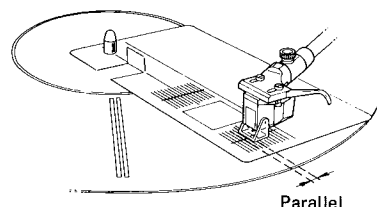

Fig. E

ALIGNMENT PROCEDURES

■ SUSPENSION ADJUSTMENT

*Conditions

1. Make sure to install the platter, rubber platter mat and disc stabilizer.
(It is not necessary for you to hang the drive belt between the platter and motor pulley.)
2. Install the cartridge and counter weight to the tonearm. (Set the tracking force to about 2g.)
Secure the tonearm with the tonearm clamp so that it does not move.
3. Be sure that the power is off.

● ADJUSTMENT

1. Adjust so that the space between platter and surface of cabinet is $4\text{mm} \pm 0.2\text{mm}$ by turning screws ① to ③ as shown in the Fig.1.
(Turning these screws clockwise moves the platter down and turning them counterclockwise moves it up.)
2. After adjustments, confirm that the platter moves up and down in the well-balanced condition even if the platter is pressed down in the cabinet.

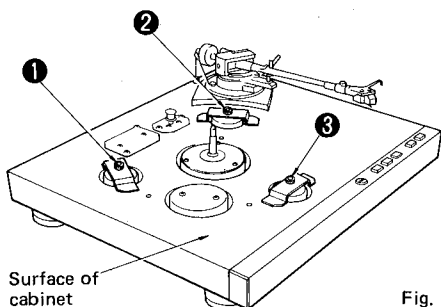

Fig. 1

■ DISC END DETECTION POSITION ADJUSTMENT

*Conditions

Be sure not to hang the drive belt between platter and motor pulley.

Quartz Lock Switch ON (button in)

Lift Switch auto

● LP POSITION ADJUSTMENT

1. Depress the 33-speed button.
2. Lower the cue lever. (Arm Lifter is set to the low position.)
3. Adjust the adjustment screw so that the stylus of cartridge detects the disc end position between $111.94\text{mm} \sim 107.2\text{mm}$ from the center of spindle.

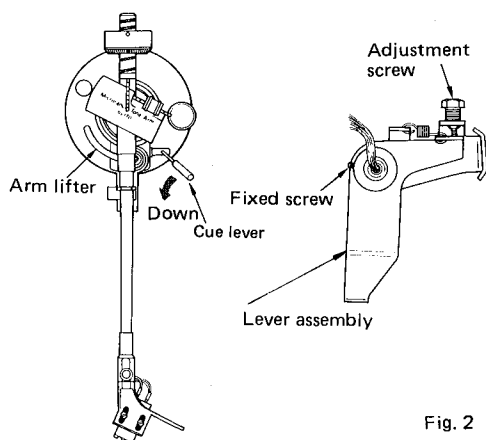

Fig. 2

● EP POSITION ADJUSTMENT

1. Depress the 45-speed button.
2. Lower the cue lever. (Arm Lifter is set to the low position.)
3. Adjust the adjustment screw so that the stylus of cartridge detects the disc end position between $102.74\text{mm} \sim 98.4\text{mm}$ from the center of spindle.

NOTE:

1. Turn the adjustment screw clockwise for slower lift-up and counterclockwise for faster lift-up.
2. If it is not within the rate, assumedly, it result from the attached position of lever assembly. Try to change the attaching position by loosening the fixed screw.
3. When the disc end position is detected, the motor revolution stops, and arm lifter is raised.
If you are going to start it again, place the tonearm on armrest once.

■ MOTOR R.P.M. ADJUSTMENT

* Instruments

Frequency Counter

* Conditions

1. Be sure that the drive belt between platter and motor pulley is hang.
2. Flip the cue lever forward to lift the tonearm up.

● ADJUSTMENT

1. Depress the 33-speed button.
2. Set the quartz lock button so that it is in the up position. (In this state, the quartz lock indicator will not light even when the platter rotates.)
3. Set the speed control knob to the center position.
4. Connect the frequency counter to TP1 (+) and TP2 (-). (Refer to PCB-1 on page 13.)
5. Move tonearm over the platter, and rotate the platter.
6. Adjust VR101 so that the frequency becomes 124.8 kHz.

NOTE: Be sure to use the insulated screwdriver for adjustment.

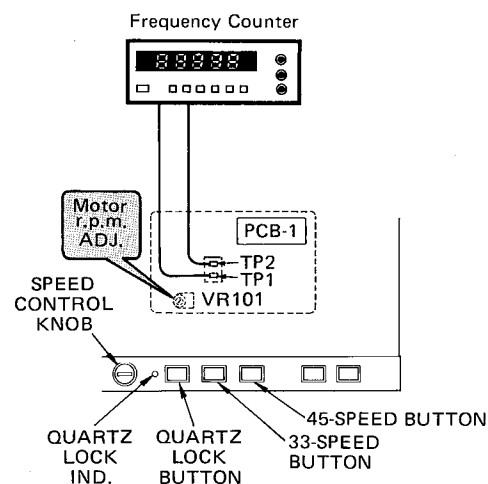
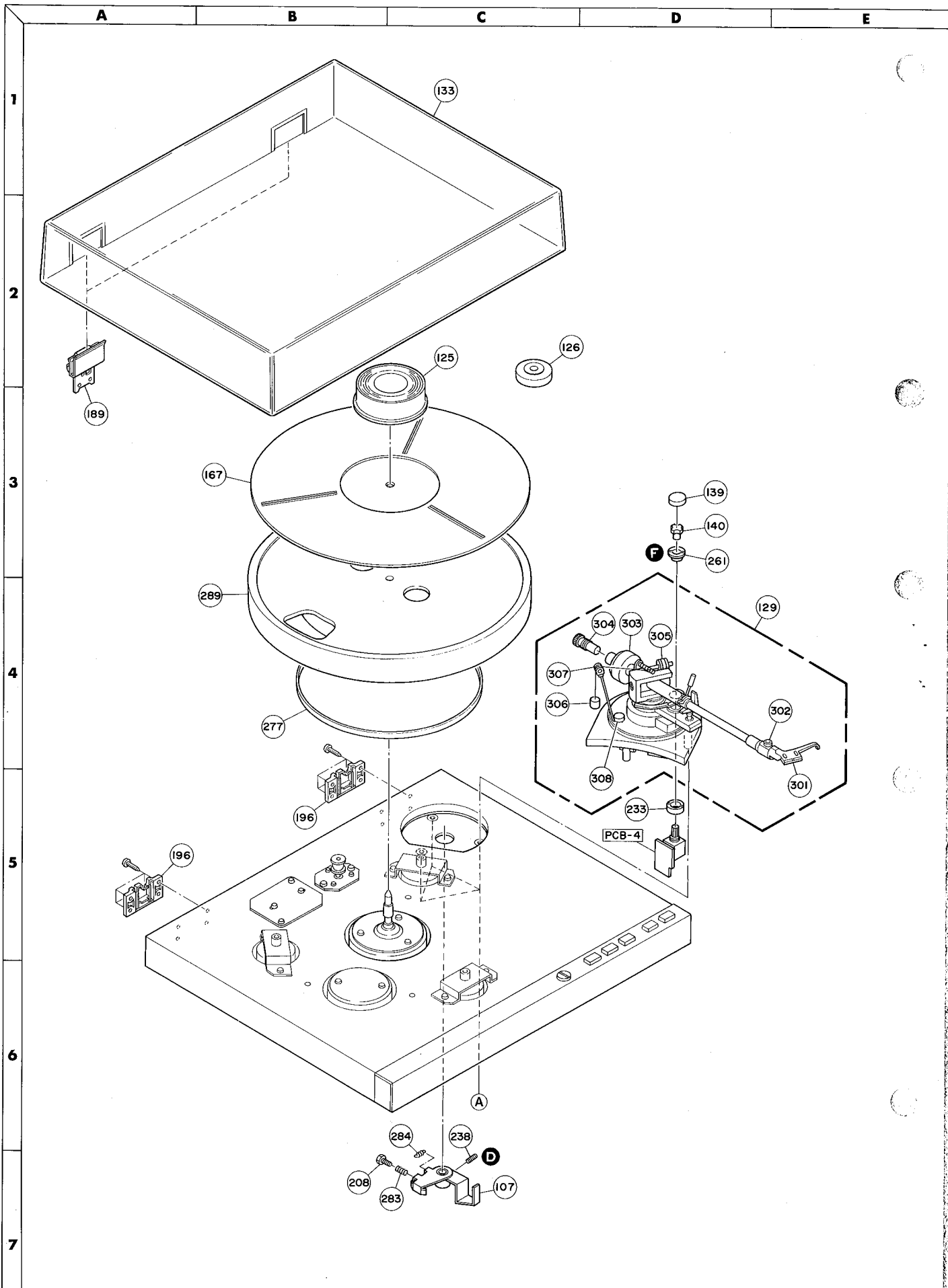
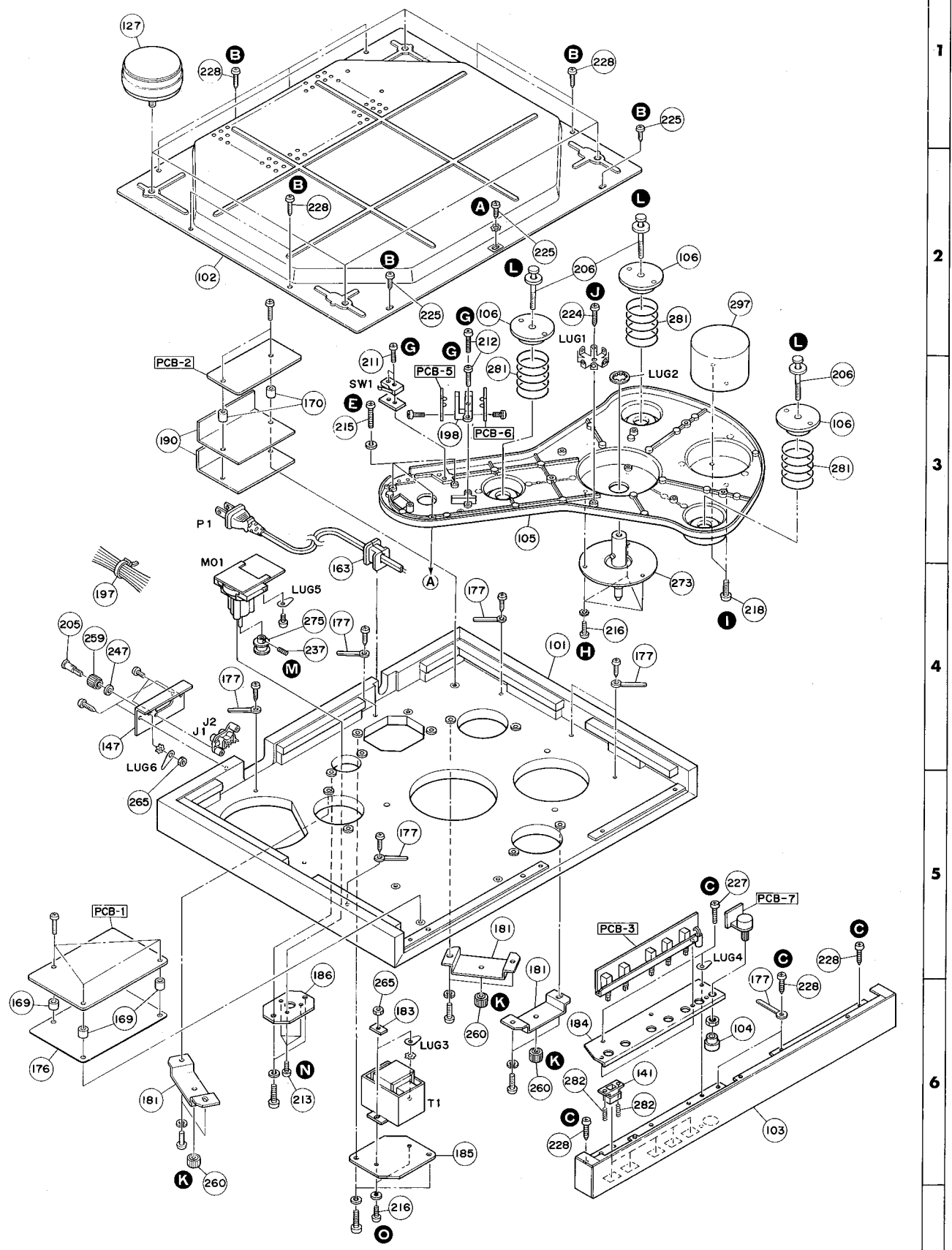

Fig. 3

GENERAL UNIT EXPLODED VIEW



F G H I J



1
2
3
4
5
6
7

GENERAL UNIT PARTS LIST

Ref. No.	Part No.	Description
101	A415-T65CA	Cabinet Assembly (for U.S.A. and Canada models)
"	A415-T65CC	Cabinet Assembly (for General model)
"	A415-T65CD	Cabinet Assembly (for General model Military version)
102	A424-T65CA	Cabinet Bottom Assembly (for U.S.A. model)
"	A424-T65CB	Cabinet Bottom Assembly (for Canada model)
"	A424-T65CC	Cabinet Bottom Assembly (for General model)
103	A443-T65CA	Front Panel Assembly
104	A634-T65CA	Knob Assembly, Speed Control
105	B211-T65CA	Chassis Assembly (for U.S.A. and Canada models)
"	B211-T65CC	Chassis Assembly (for General model)
106	B219-T65CA	Bracket Assembly, Spring Hold
107	B672-T65CA	Lever Assembly, Auto-up
108	B219-T65CA	Bracket Assembly, Spring Hold
125	1161-00101	Disc Stabilizer
126	1362-7007	45 R.P.M. Adaptor
127	1319-0147	Foot
129	1371-717	Pick-up Assembly (w/L1)
133	1472-01301	Dust Cover
139	1634-05001	Knob, Cap. Trim
140	1355-7040	Knob Base, Cap. Trim
141	1660-00201	Push Button, Quartz Lock, 33/45 Speed, Lift, Cut
147	1724-02601	Indication Plate
163	2114-71264	Bushing, Power Cord (for U.S.A. and Canada models)
"	2114-71270	Bushing, Power Cord (for General model)
167	2115-00101	Platter Mat
169	2132-01401	Spacer
170	2132-7016	Spacer
176	2216-7134	Shield Plate
177	2218-7001	Holding Bracket
181	2219-7865	Bracket
183	2219-7359	Bracket
184	2219-8003	Bracket
185	2219-8004	Bracket
186	2219-8005	Bracket
189	2221-7120	Hinge
190	2224-7074	Insulator
196	2240-7194	Holder
197	2240-7120	Holder
198	2240-7227	Holder
205	2310-7015	Special Screw, GND
206	2310-7020	Special Screw
208	2316-300829	Hexagon-head Screw
211	2327-231029	Screw (+) (2.3X10 mm)
212	2327-300629	Screw (+) (3X6 mm)
213	2327-300649	Screw (+) (3X6 mm)
215	2327-301229	Screw (+) (3X12 mm)
216	2327-301249	Screw (+) (3X12 mm)
218	2327-401449	Screw (+) (4X14 mm)
224	2347-300822	Self-tapping Screw (+) (3X8 mm)
225	2347-300842	Self-tapping Screw (+) (3X8 mm)
227	2347-301022	Self-tapping Screw (+) (3X10 mm)
228	2347-301241	Self-tapping Screw (+) (3X12 mm)
233	2360-7010	Special Boss
237	2371-260429	Set Screw, Motor Pulley
238	2374-30042D9	Set Screw, Lever Assembly
247	2410-7005	Special Washer
259	2440-7011	Special Nut, GND
260	2440-64	Special Nut
261	2440-7020	Special Nut
265	2446-30229	Hexagon-head Nut
273	2601-7108	Center Spindle Assembly
275	2618-7005	Motor Pulley
277	2642-02701	Drive Belt
281	2651-2101701	Spring
282	2651-2101702	Spring
283	2651-2101116	Spring
284	2651-110331	Spring
289	2665-715	Platter
297	2691-7001	Balancer
301	MA-1699	Headshell
302	MC-3752	Headshell Clamp
303	MC-6262	Counterweight

Ref. No.	Part No.	Description
304	MC-6112	Sub-counterweight
305	MC-6116	Lateral Balancer
306	MC-6129	Anti-skating Weight with Wire
307	MC-6263	Anti-skating Wire Holder
308	MC-6128	Set Screw

ELECTRICAL PARTS LIST

CHASSIS MISCELLANEOUS

△ P1	4161-7187	Power Cord (for U.S.A. model)
△ "	4161-71151	Power Cord (for Canada model)
△ "	4161-7256	Power Cord (for General model)
△ T1	5584-701483	Power Transformer (for U.S.A. and Canada models)
△ "	5584-702483	Power Transformer (for General model)
MO1	4311-1A159	Motor Assembly
△ SW1	4431-A017128	Microswitch, Rest
J1/2	4482-7127	2-Pin Jack, Output
△ F1	5732-801031	Fuse, 800mA, 125V (for U.S.A. and Canada models)
△ "	5732-501030	Fuse, T500mA, 250V (for General model)
L1	N.A. Separately	Solenoid, Auto-lift (Part of Pick-up Assembly)
LCN1	4163-701116	Connector with Lead Wire, 6 Pos.
LCN2	4163-701115	Connector with Lead Wire, 7 Pos.
LCN3	4163-701117	Connector with Lead Wire, 4 Pos.
LUG1	4211-5006	Lug Terminal
LUG2	2467-1406	Lug Terminal
LUG3, 4, 5, 6	4211-5005	Lug Terminal

PCB-1 MOTOR CONTROL P.C. BOARD

RESISTORS		
R101	5174-823381	82k Ω , \pm 1%, 1/4W, Metal
R102	5174-104381	100k Ω , \pm 1%, 1/4W, Metal
R106	5174-474381	470k Ω , \pm 1%, 1/4W, Metal
R107	5174-562381	5.6k Ω , \pm 1%, 1/4W, Metal
R119	5174-393381	39k Ω , \pm 1%, 1/4W, Metal
CONTROL		
VR101	5101-1031926	10k Ω
CAPACITORS		
C101, 114	5345-474F041	0.47 μ F, \pm 20%, 50V, Electrolytic
C104, 108	5345-476C041	47 μ F, \pm 20%, 16V, Electrolytic
C105	5345-107C041	100 μ F, \pm 20%, 16V, Electrolytic
C106	5345-227C041	220 μ F, \pm 20%, 16V, Electrolytic
C109	5345-107C041	100 μ F, \pm 20%, 16V, Electrolytic
C110	5345-225F0952	2.2 μ F, \pm 20%, 50V, Electrolytic
C113	5345-225F041	2.2 μ F, \pm 20%, 50V, Electrolytic
C201	5345-106C041	10 μ F, \pm 20%, 16V, Electrolytic
C202	5345-475F0952	4.7 μ F, \pm 20%, 50V, Electrolytic
C203	5345-475F041	4.7 μ F, \pm 20%, 50V, Electrolytic
INTEGRATED CIRCUIT		
IC101	5654-TC9142P	TC9142P
IC102	5654-TC4069BP	TC4069UBP
TRANSISTORS		
Q101, 102, 103, 104, 105, 201, 203	5613-2603(E)	2SC2603(E) or 2SC2603(F)
Q106	5611-1115(E)	2SA1115(E) or 2SA1115(F)
Q202	5613-3246(H)	2SC3246(H)
DIODES		
D101	5635-HZ9B3L	Zener, HZ9B3L
D102, 201	5631-1S2473	1S2473
D202	5632-1SR35-10	1SR35-100
MISCELLANEOUS		
X101	5691-03993623	Crystal, Osc.
SCR201	5661-03P05M	Thyristor, 03P05M
CN1	4443-064116	Connector, 6 Pos.
CN2	4443-074116	Connector, 7 Pos.

Ref. No.	Part No.	Description
PCB-2 POWER SUPPLY P.C. BOARD		
CAPACITORS		
C3, 4	5345-228D041	2200 μ F, \pm 20%, 25V, Electrolytic
C5, 6, 7, 8	5345-227C041	220 μ F, \pm 20%, 16V, Electrolytic
C9	5345-475F041	4.7 μ F, \pm 20%, 50V, Electrolytic
TRANSISTORS		
Q1	5614-669(C)	2SD669(C)
Q2	5612-649(C)	2SB649(C)
DIODES		
Δ D1, 2, 5	5632-1SR35-10	1SR35-100
D3, 4	5635-HZ11B3L	Zener, HZ11B3L
MISCELLANEOUS		
Δ P3/4	4442-2	Connector (General model only)
Δ J3/4	D443-T55CA	Connector with Lead Wire (General model only)
	4472-0131	Fuse Holder (X2)
PCB-3 CONTROL SWITCHES P.C. BOARD		
CAPACITOR		
C112	5345-476C041	47 μ F, \pm 20%, 16V, Electrolytic
DIODE		
D401	5637-GL5HD10	L.E.D., GL5HD10, Quartz Lock Indicator
MISCELLANEOUS		
SW401, 402, 403, 404, 405	4431-05107154	Push Switch, Cut, Lift, 45/33 Speed, Quartz Lock
PCB-4 CAPACITANCE TRIM SELECTOR P.C. BOARD		
CAPACITORS		
C701, 702, 703, 704	5359-2015851	200pF, \pm 5%, 100V, Polypropylene
MISCELLANEOUS		
SW701	4411-203722	Rotary Switch, Cap. Trim
PCB-5 LED P.C. BOARD		
CAPACITOR		
C705	5345-476C0951	47 μ F, \pm 20%, 16V, Electrolytic
DIODE		
D701, 702	5637-TLR108A	L.E.D., TLR108A
PCB-6 PHOTO TRANSISTOR P.C. BOARD		
Q701, 702	5621-PT350F	Photo Transistor, PT350F
PCB-7 SPEED CONTROL P.C. BOARD		
VR401	5113-50273136	5k Ω B, Speed Control

Δ SAFETY RELATED COMPONENT. USE ONLY EXACT REPLACEMENT PART AS SPECIFIED.

PACKAGE

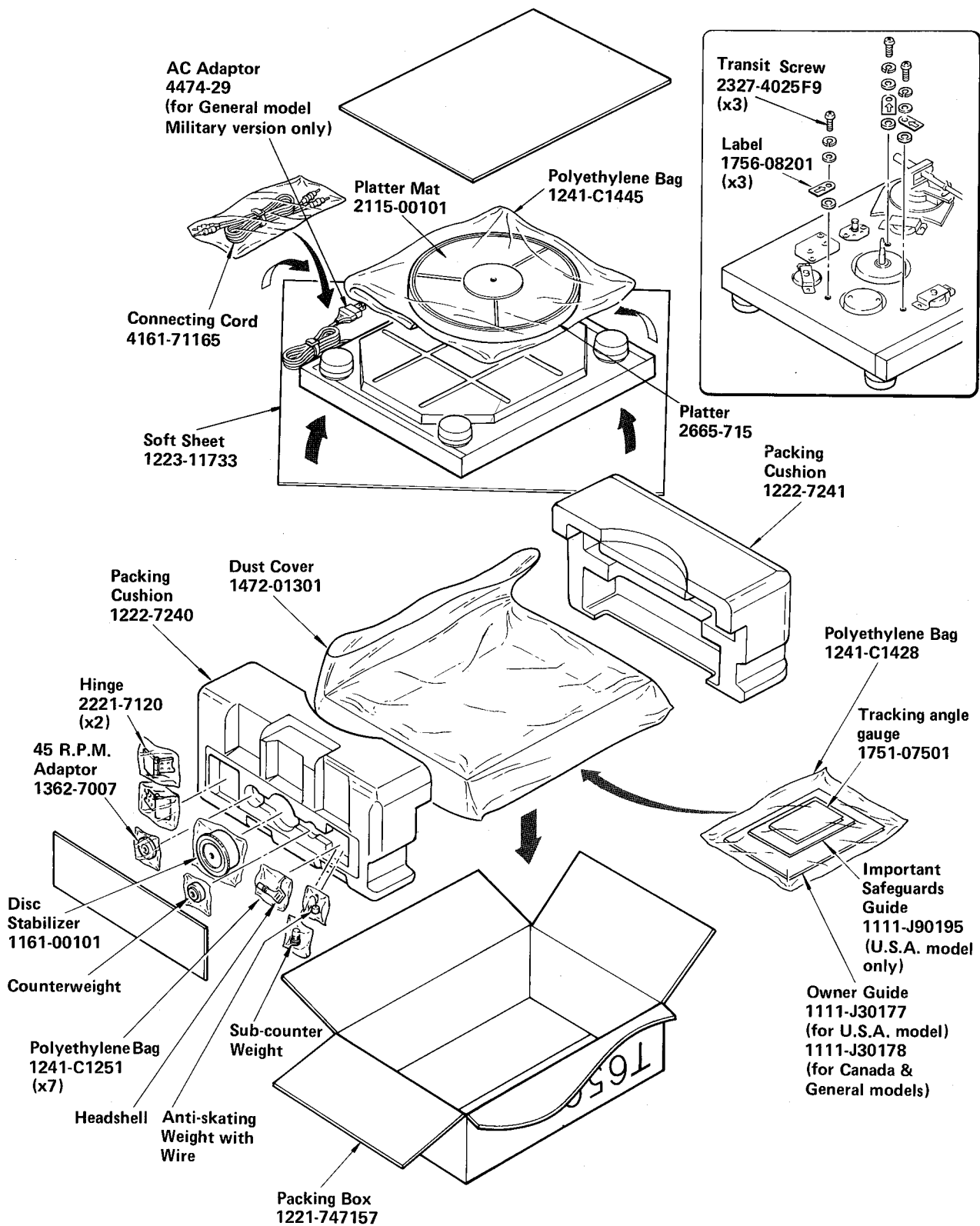

SCHEMATIC DIAGRAM

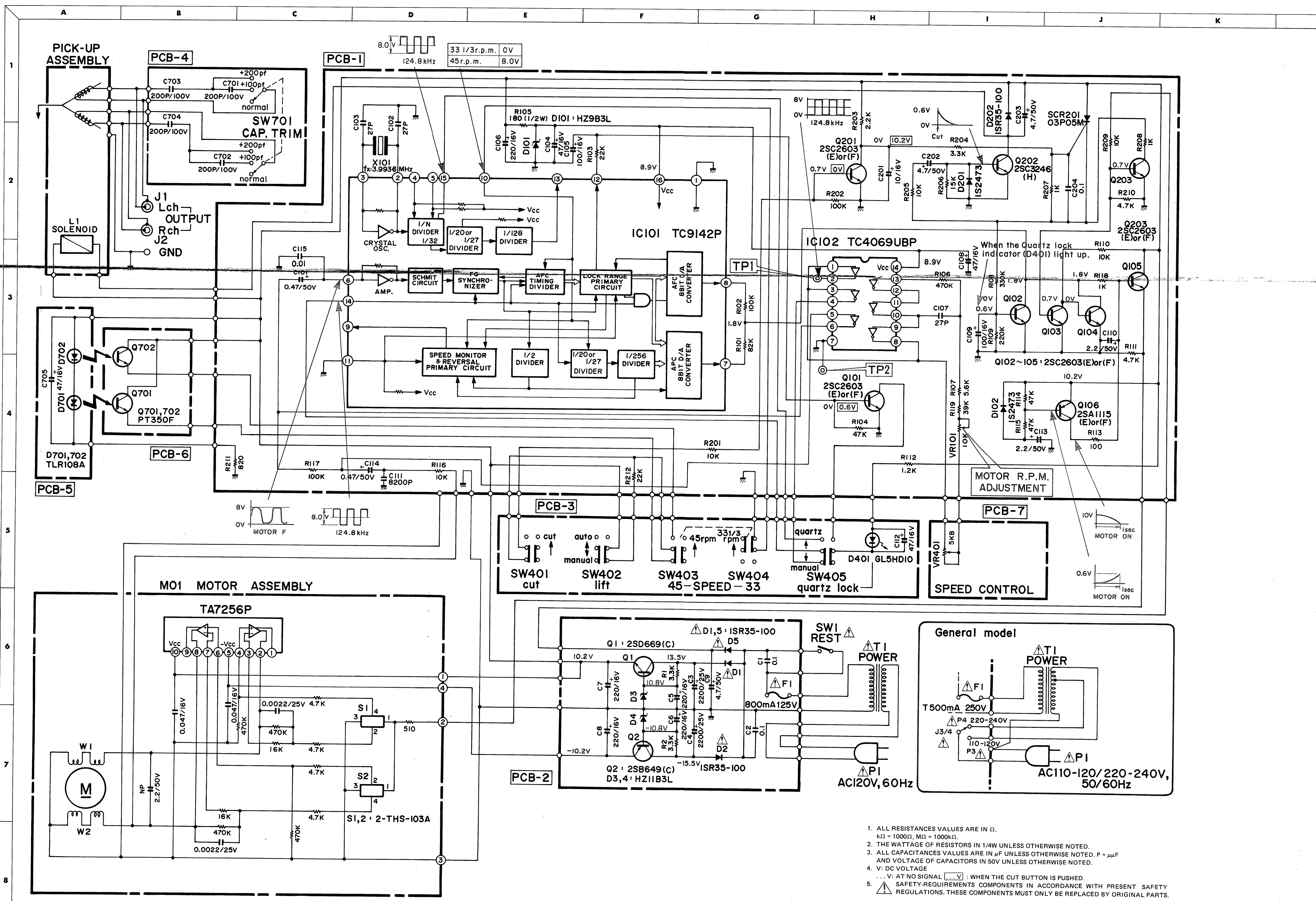

1. ALL RESISTANCES VALUES ARE IN Ω.
kΩ = 1000Ω, MΩ = 1000kΩ.
2. THE WATTAGE OF RESISTORS IN 1/4W UNLESS OTHERWISE NOTED.
3. ALL CAPACITANCES VALUES ARE IN μF UNLESS OTHERWISE NOTED. P = μF
AND VOLTAGE OF CAPACITORS IN 50V UNLESS OTHERWISE NOTED.
4. V: DC VOLTAGE
... V: AT NO SIGNAL [] : WHEN THE CUT BUTTON IS PUSHED.
5. SAFETY-REQUIREMENTS COMPONENTS IN ACCORDANCE WITH PRESENT SAFETY REGULATIONS. THESE COMPONENTS MUST ONLY BE REPLACED BY ORIGINAL PARTS.

SCHEMATIC DIAGRAM

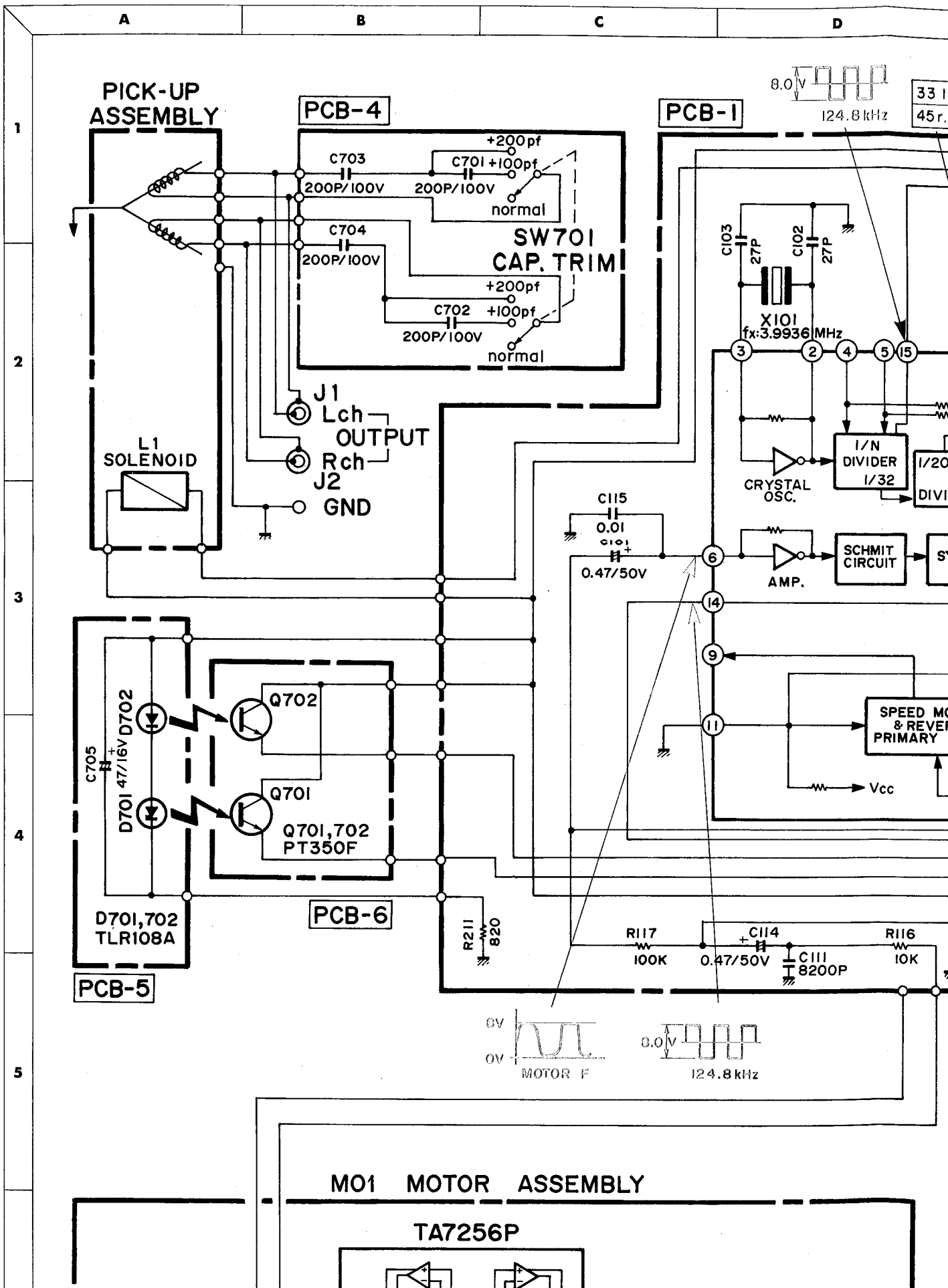

24.8 kHz	33 1/3 r.p.m.	0V
	45 r.p.m.	8.0V

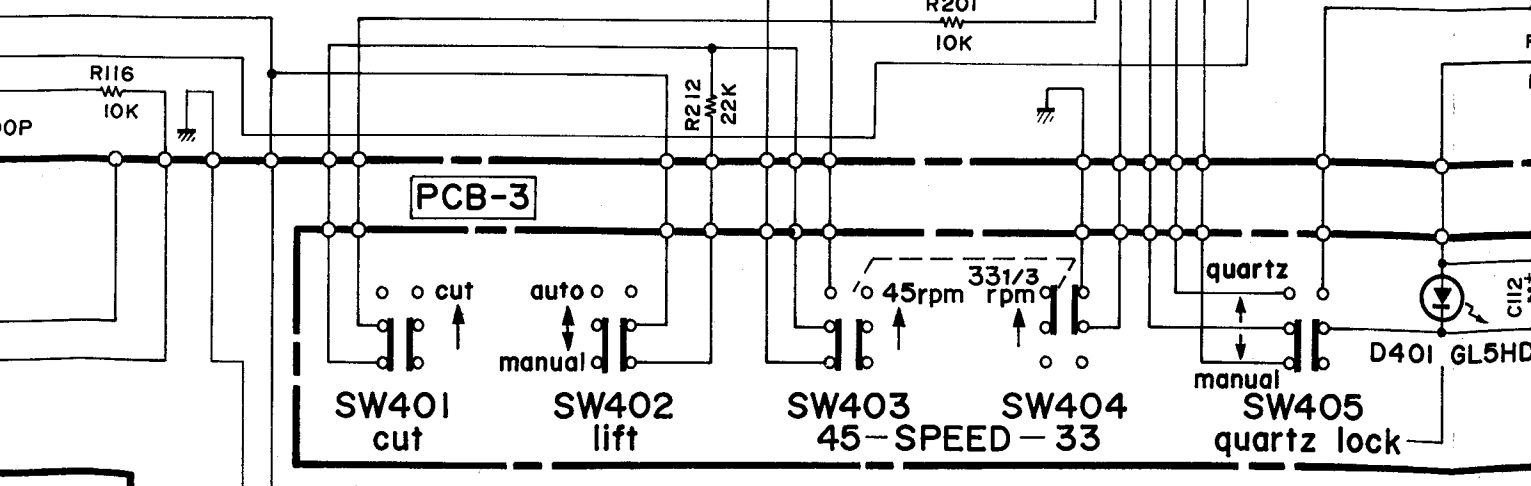
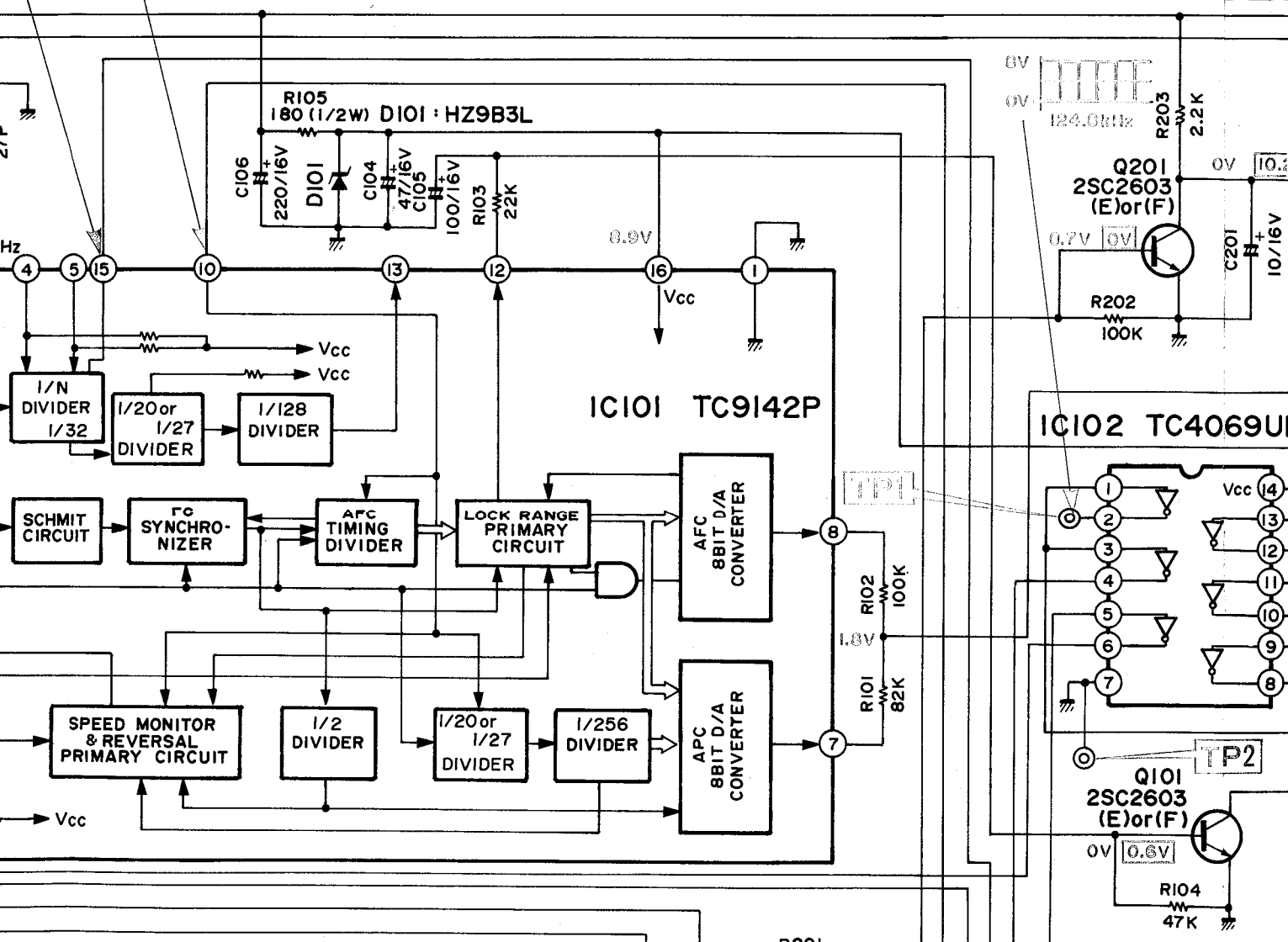

DI,5:ISR35-100

SW1 REST

H

I

J

K

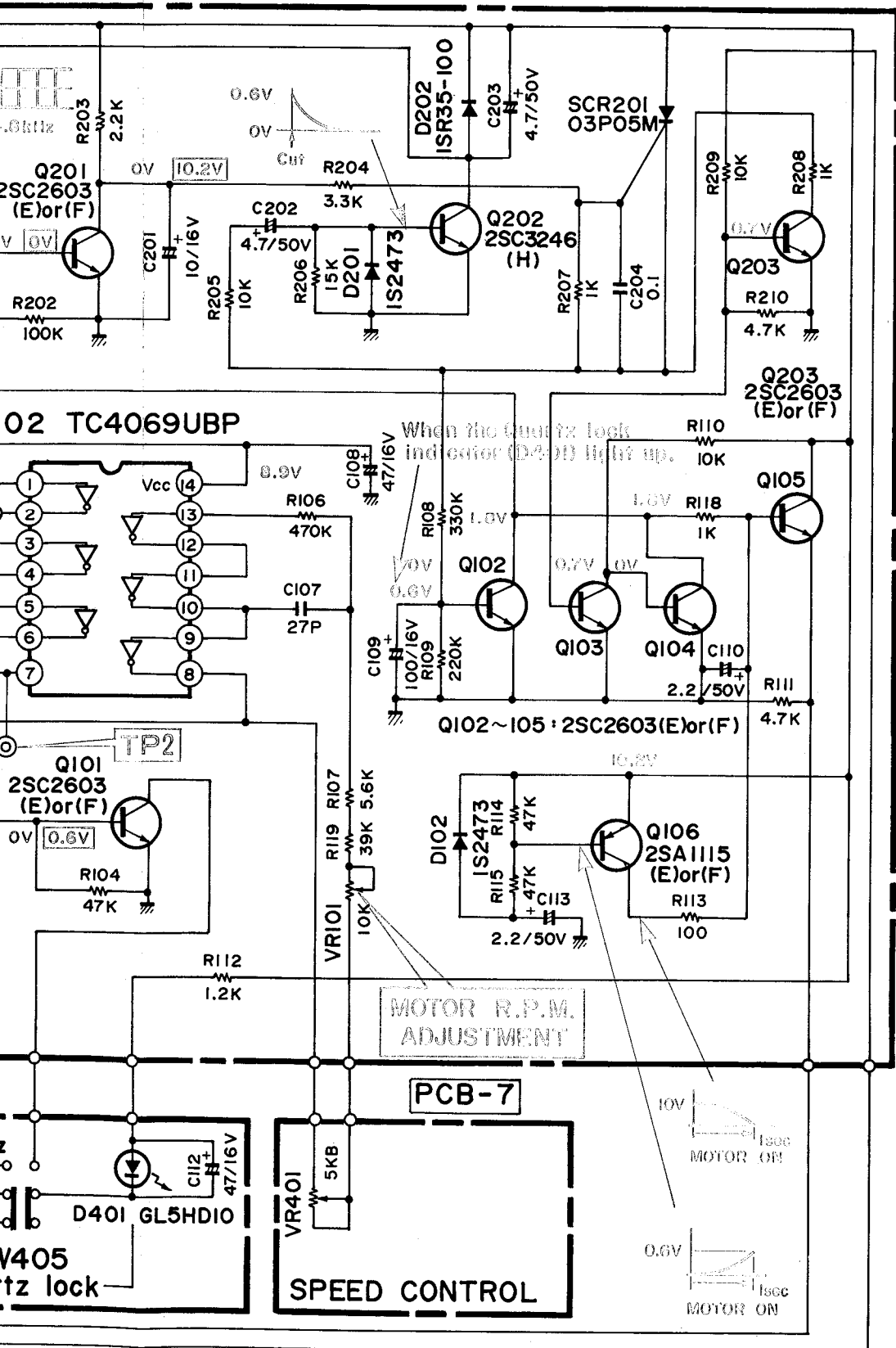

SWI
EST

General model

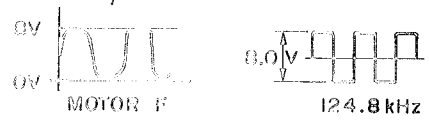
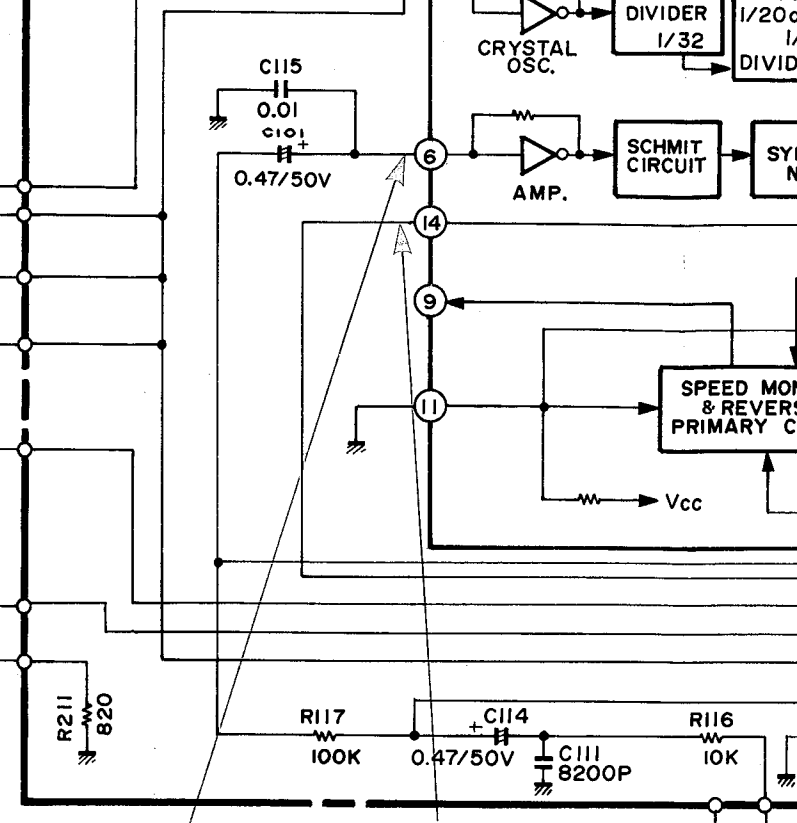
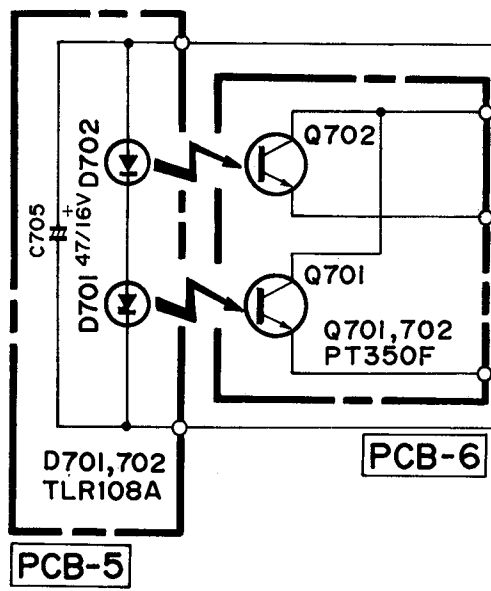
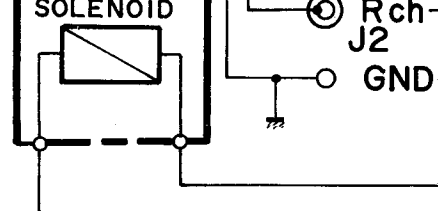

MO1 MOTOR ASSEMBLY

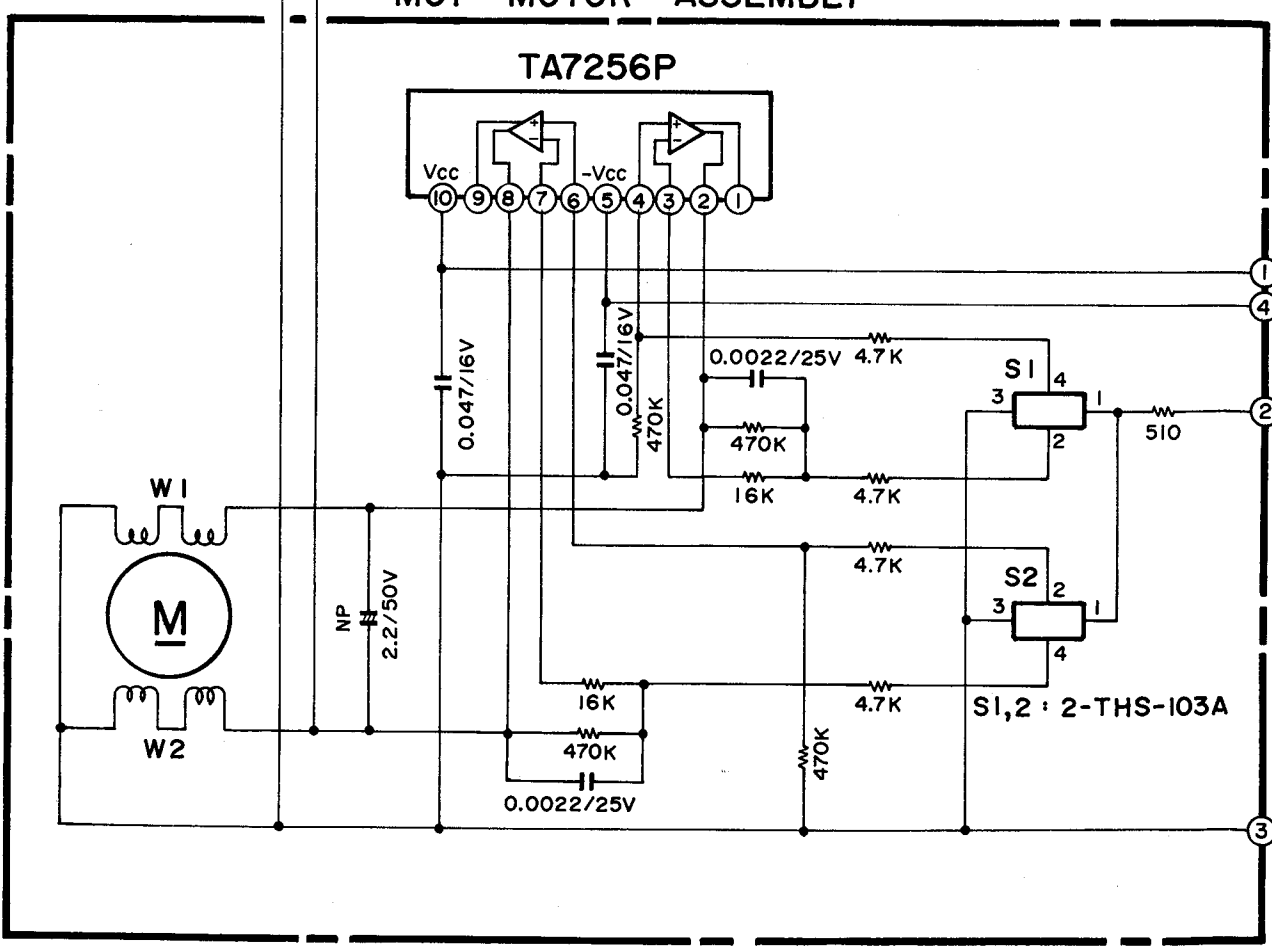

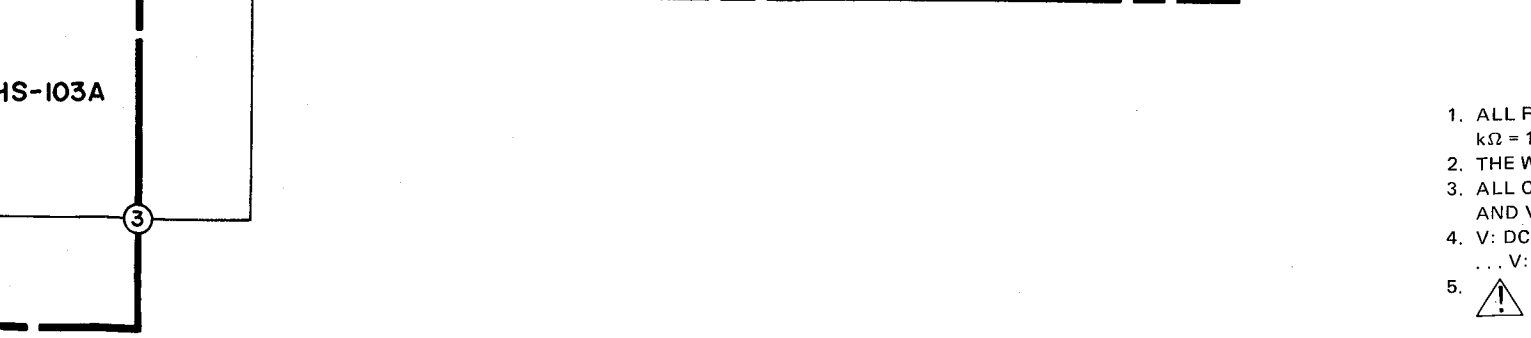
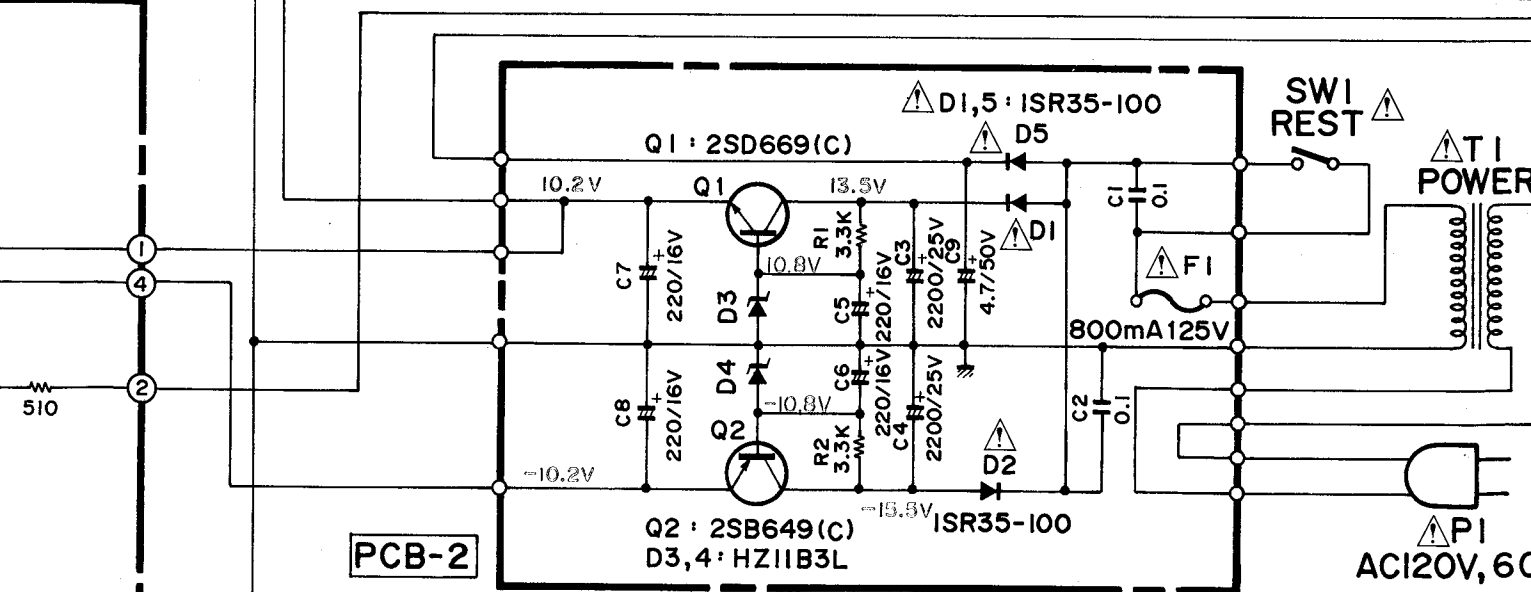
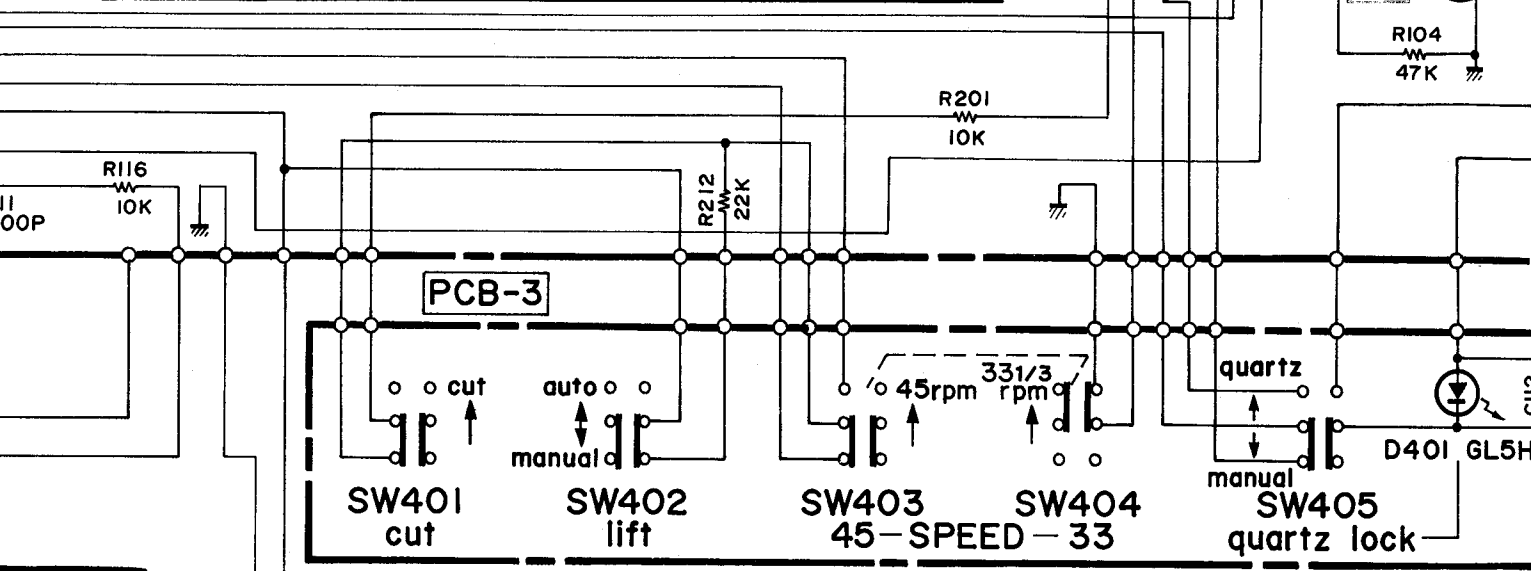
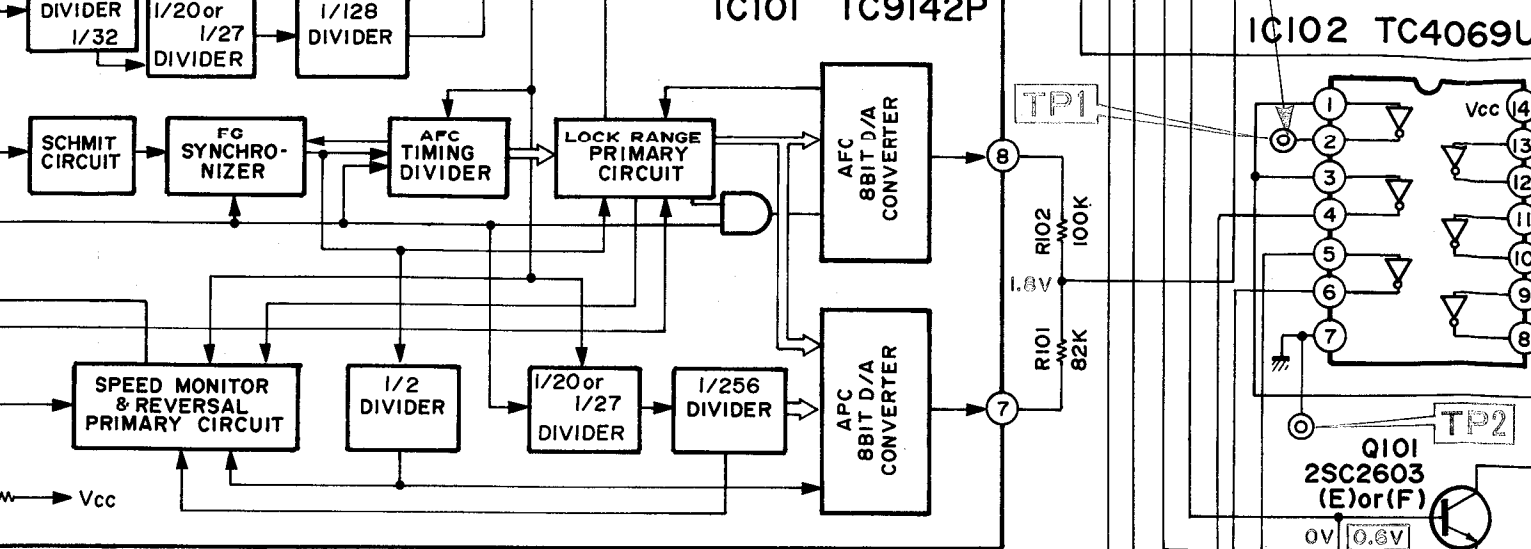

1. ALL P...
2. THE W...
3. ALL C...
4. V: DC...
5. ⚠

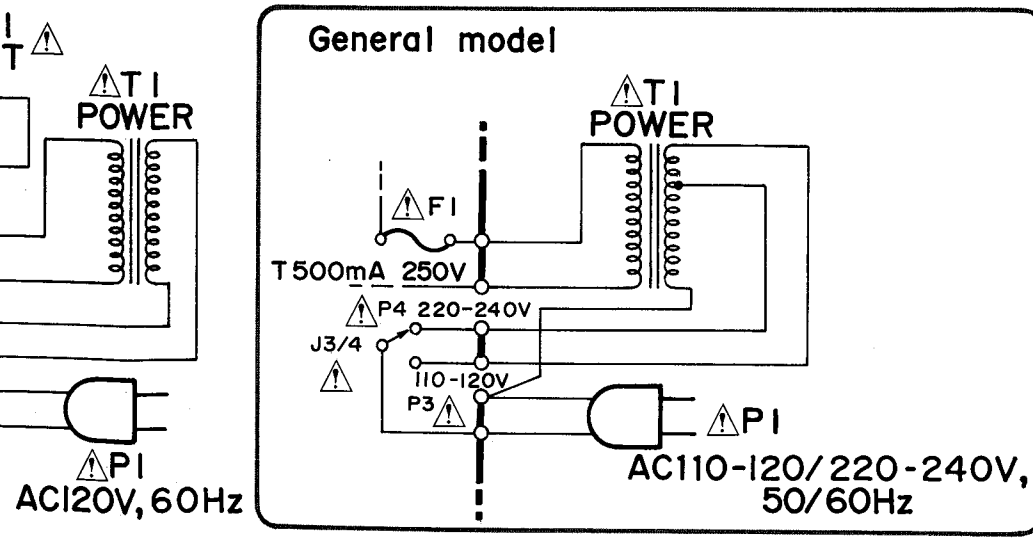
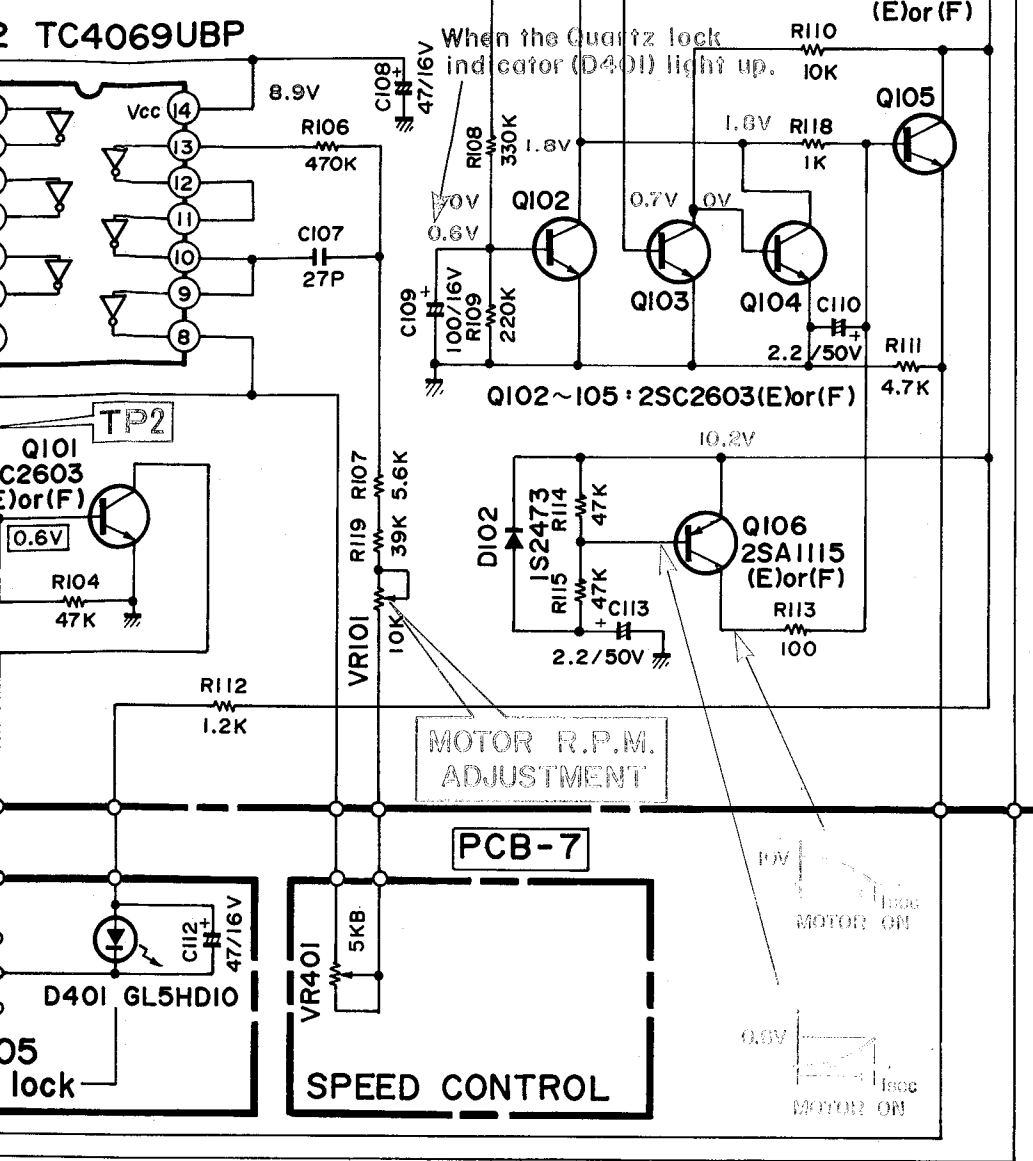

1. ALL RESISTANCES VALUES ARE IN Ω .
k Ω = 1000 Ω , M Ω = 1000k Ω .
2. THE WATTAGE OF RESISTORS IN 1/4W UNLESS OTHERWISE NOTED.
3. ALL CAPACITANCES VALUES ARE IN μ F UNLESS OTHERWISE NOTED. P = μ F AND VOLTAGE OF CAPACITORS IN 50V UNLESS OTHERWISE NOTED.
4. V: DC VOLTAGE
... V: AT NO SIGNAL ... V : WHEN THE CUT BUTTON IS PUSHED.
5. SAFETY-REQUIREMENTS COMPONENTS IN ACCORDANCE WITH PRESENT SAFETY REGULATIONS. THESE COMPONENTS MUST ONLY BE REPLACED BY ORIGINAL PARTS.

WIRING DIAGRAM

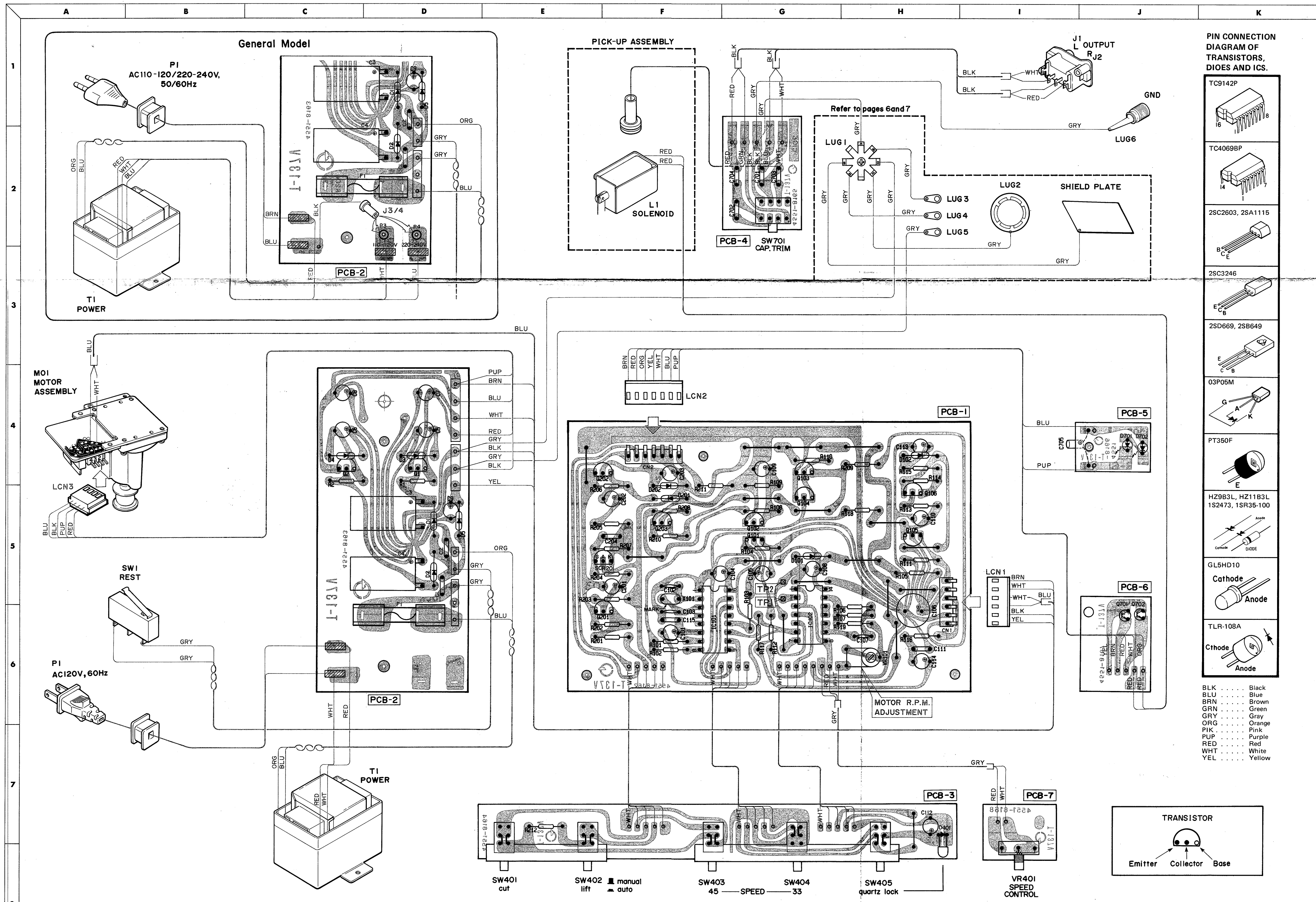

PIN CONNECTION DIAGRAM OF TRANSISTORS, DIODES AND ICS.

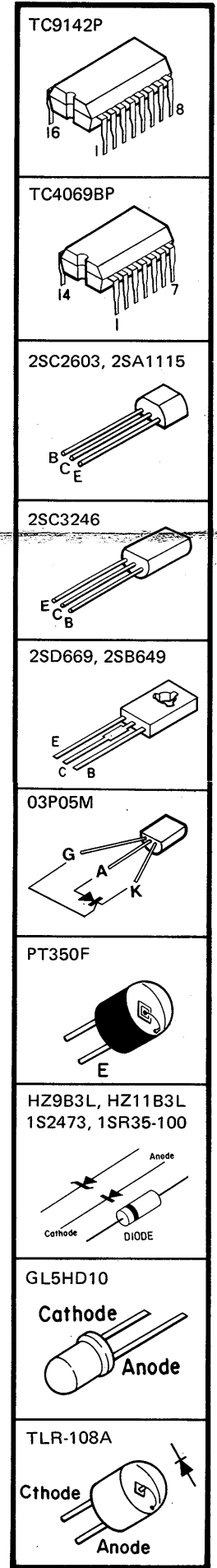

- BLK Black
- BLU Blue
- BRN Brown
- GRN Green
- GRY Gray
- ORG Orange
- PNK Pink
- PUR Purple
- RED Red
- WHT White
- YEL Yellow

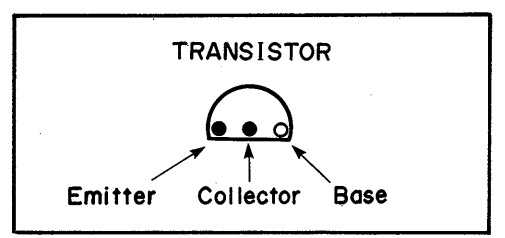

WIRING DIAGRAM

A B C D

1

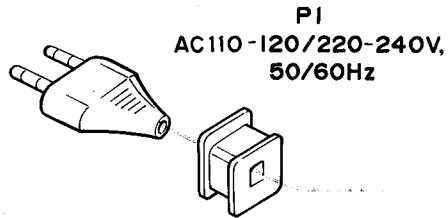

2

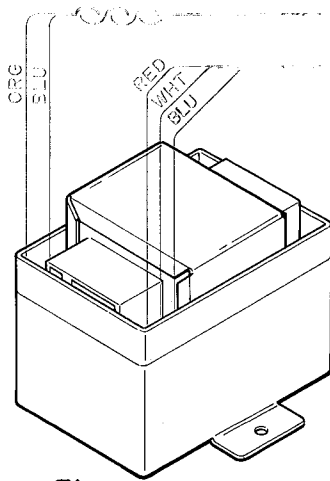

3

TI
POWER

General Model

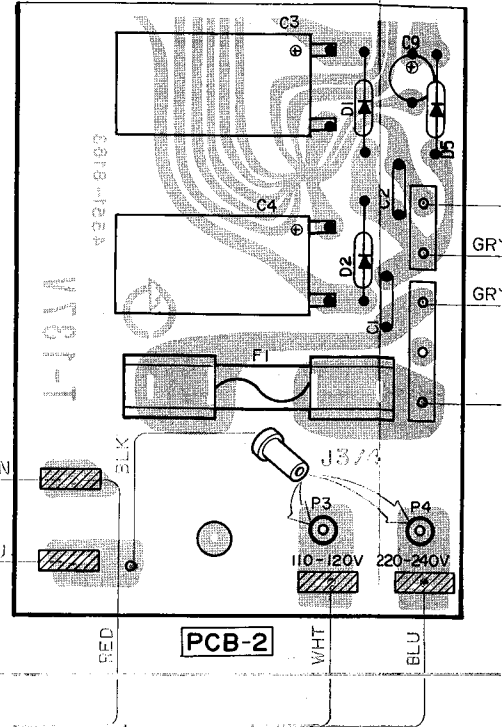

4

MOI
MOTOR
ASSEMBLY

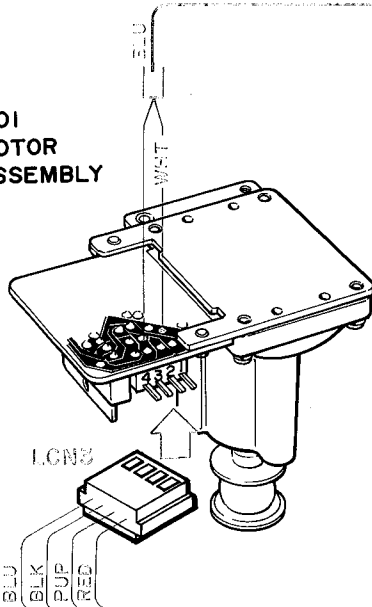

5

SWI
REST

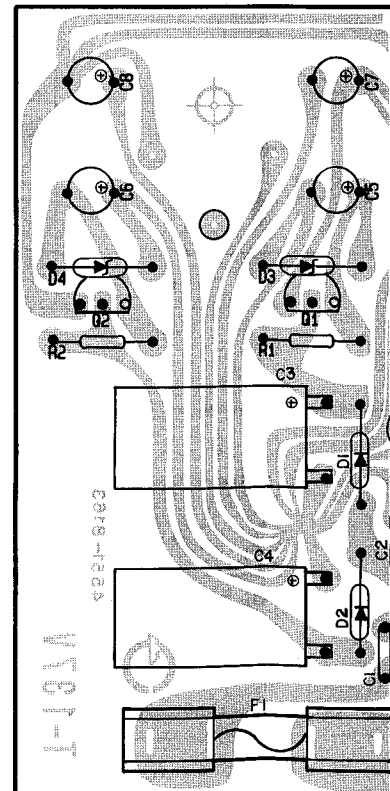
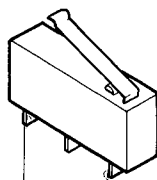

D

E

F

G

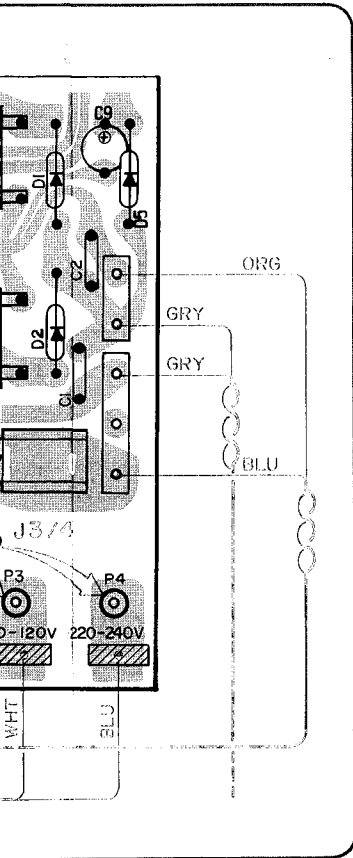

PICK-UP ASSEMBLY

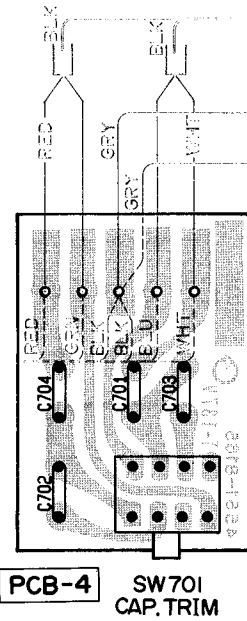
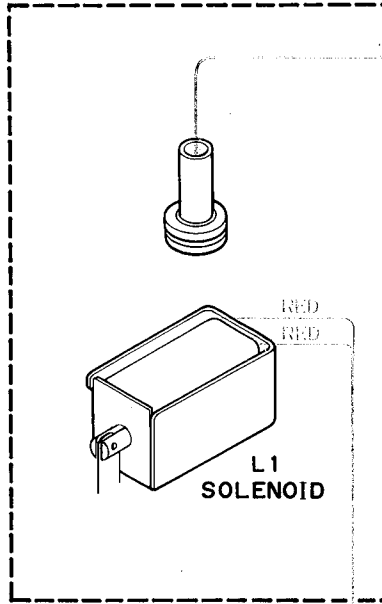

Refer to pages 60

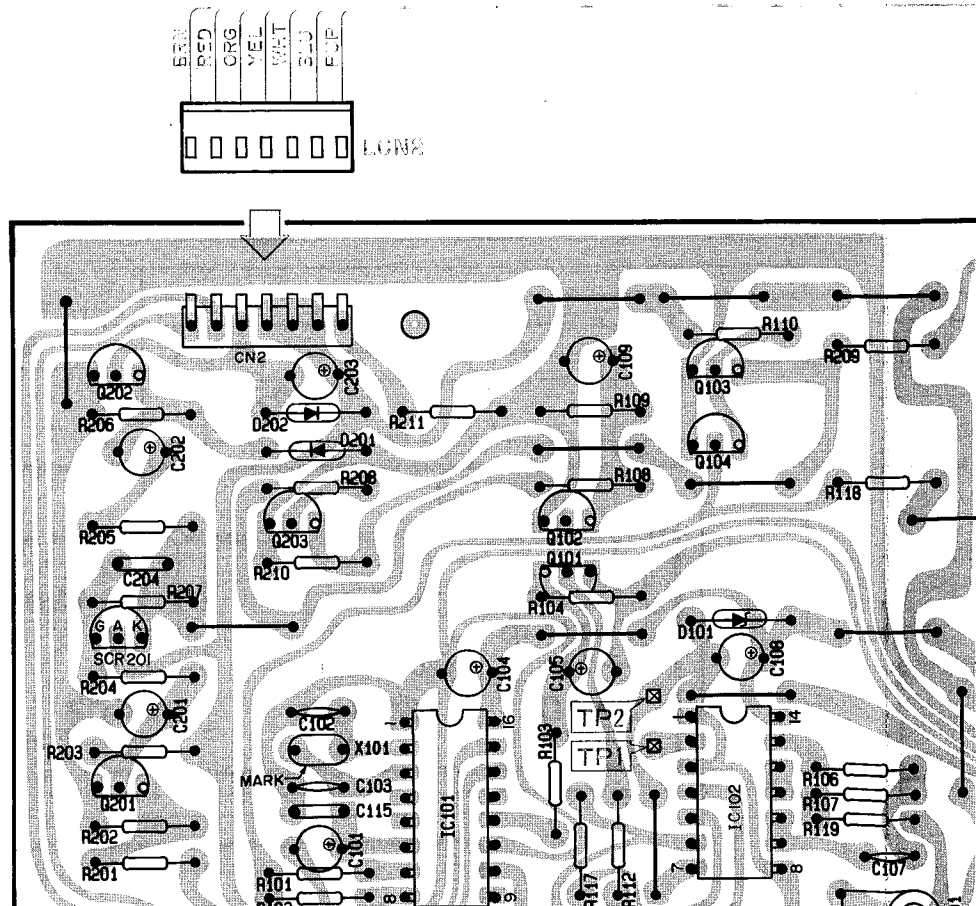
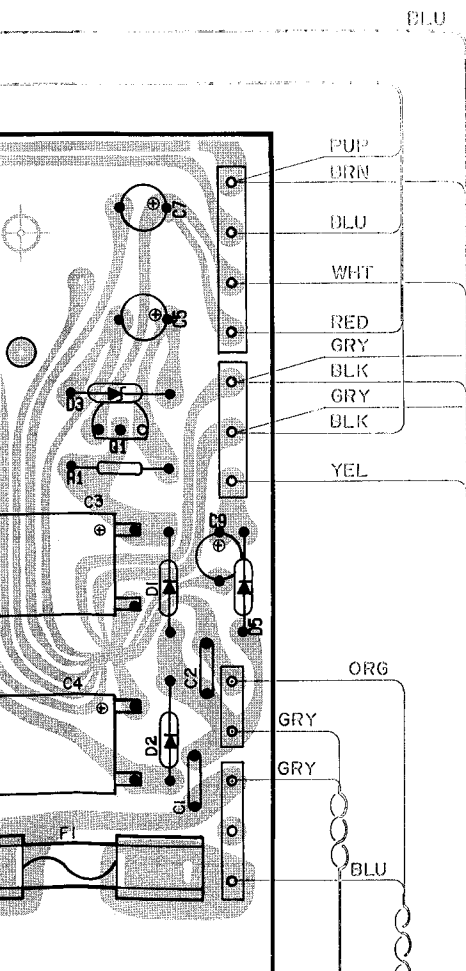
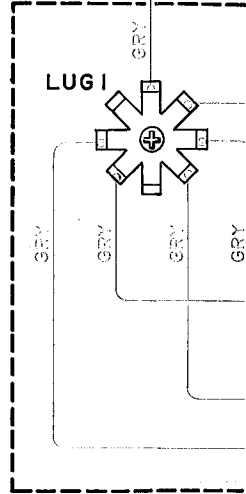

H

I

J

K

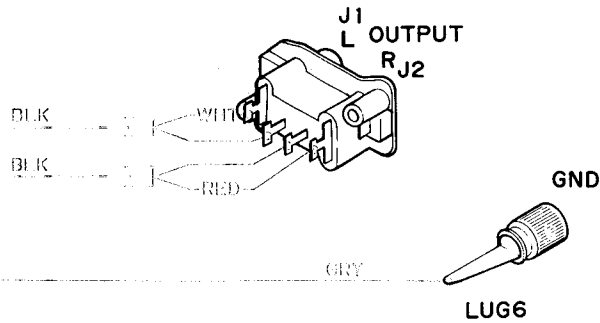

Refer to pages 6 and 7

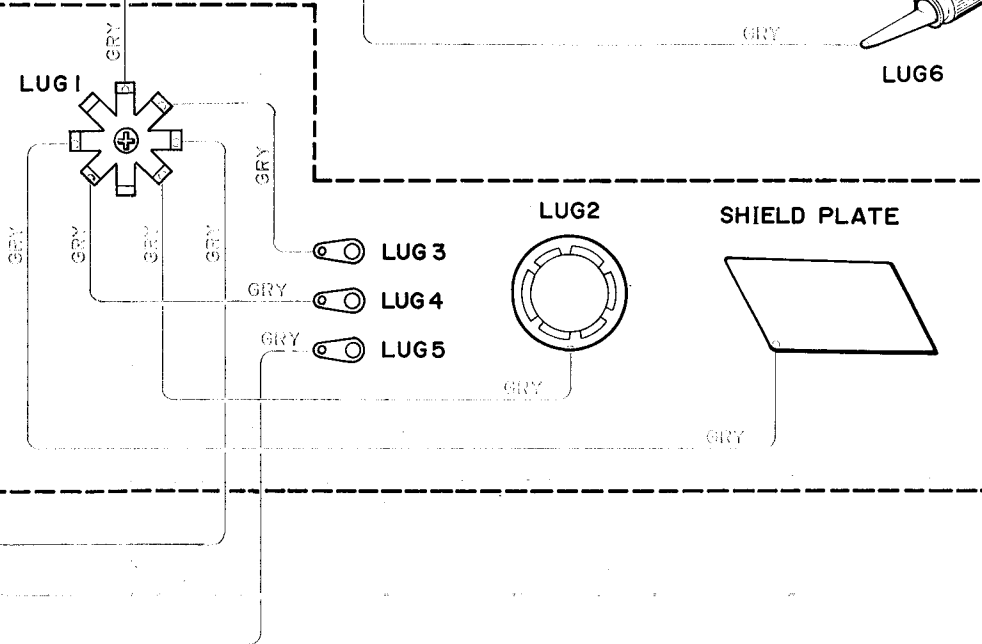

PIN CONNECTION DIAGRAM OF TRANSISTORS, DIODES AND ICS.

- TC9142P
- TC4069BP
- 2SC2603, 2SA1115
- 2SC3246
- 2SD669, 2SB649
- O3P05M
- PT350F
- HZ9B3L, HZ11B3L
1S2473, 1SR35-100
- GL5HD10
- TLR-108A

PCB-1

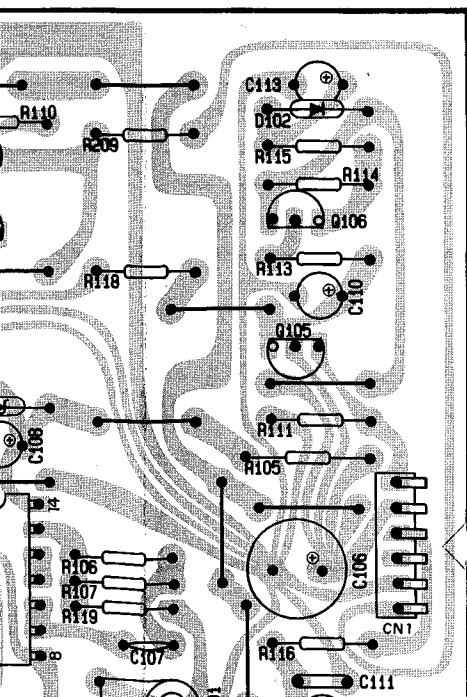

PCB-5

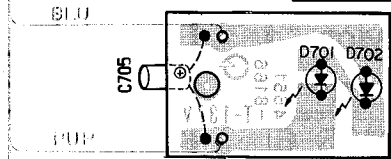

PCB-6

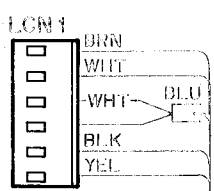
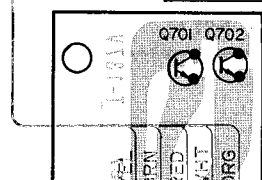

3

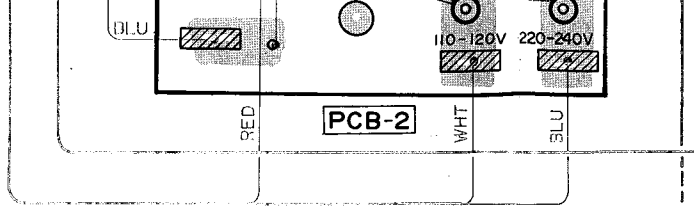
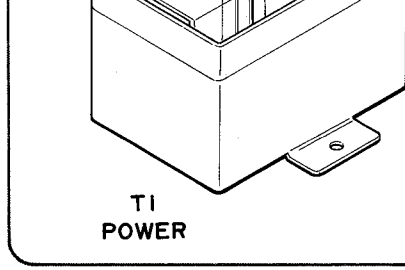

4

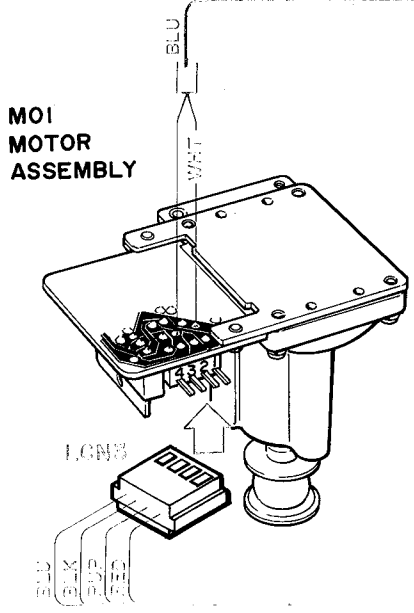

5

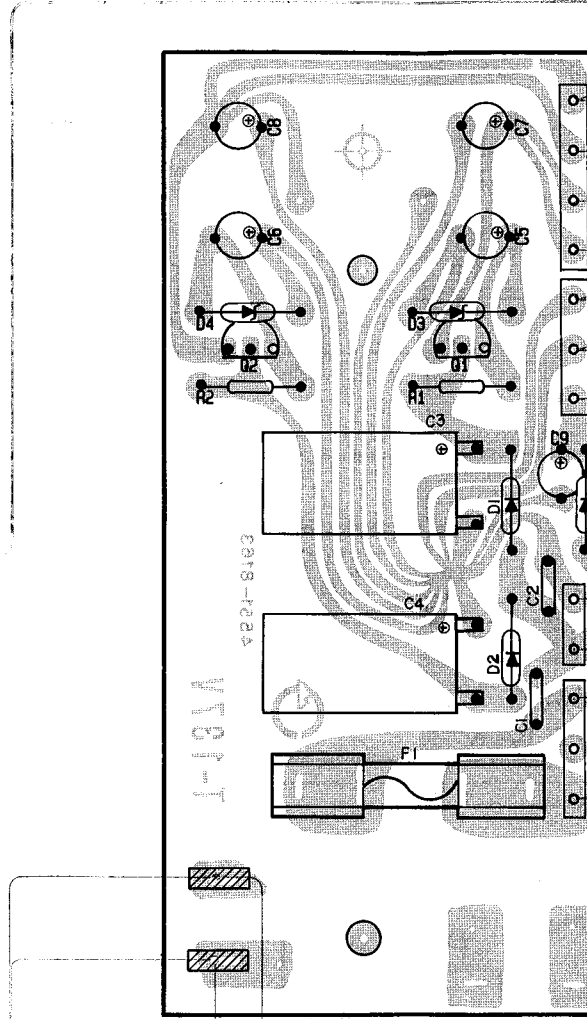

6

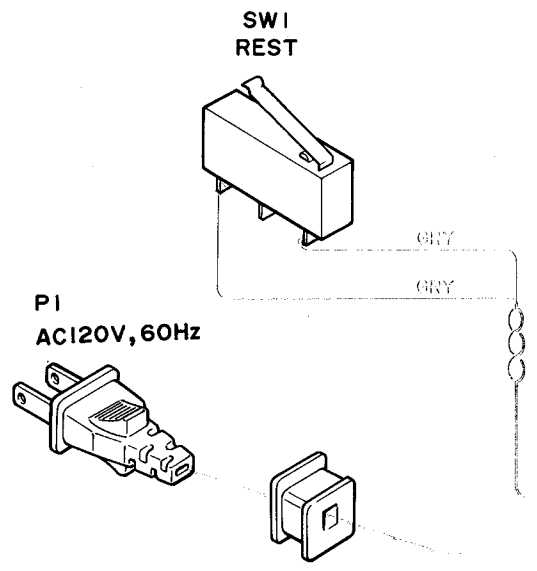

7

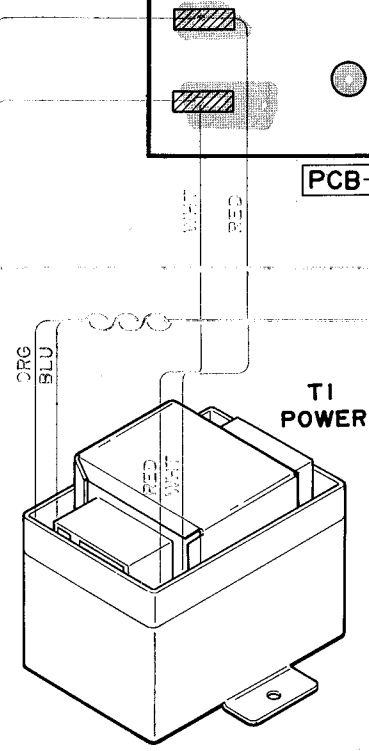

8

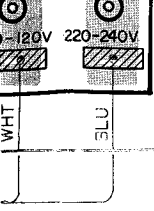

PCB-4 SW701 CAP. TRIM

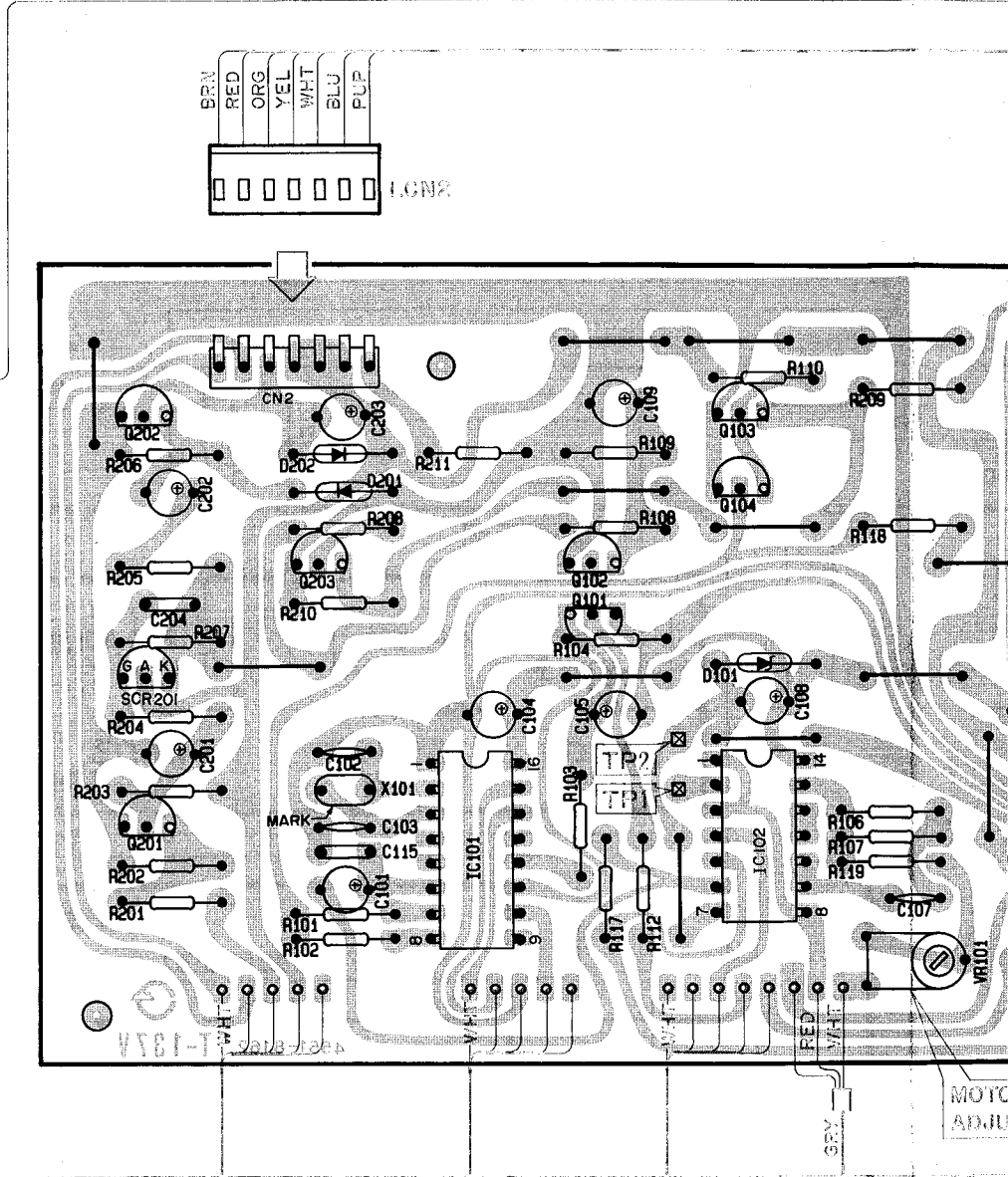
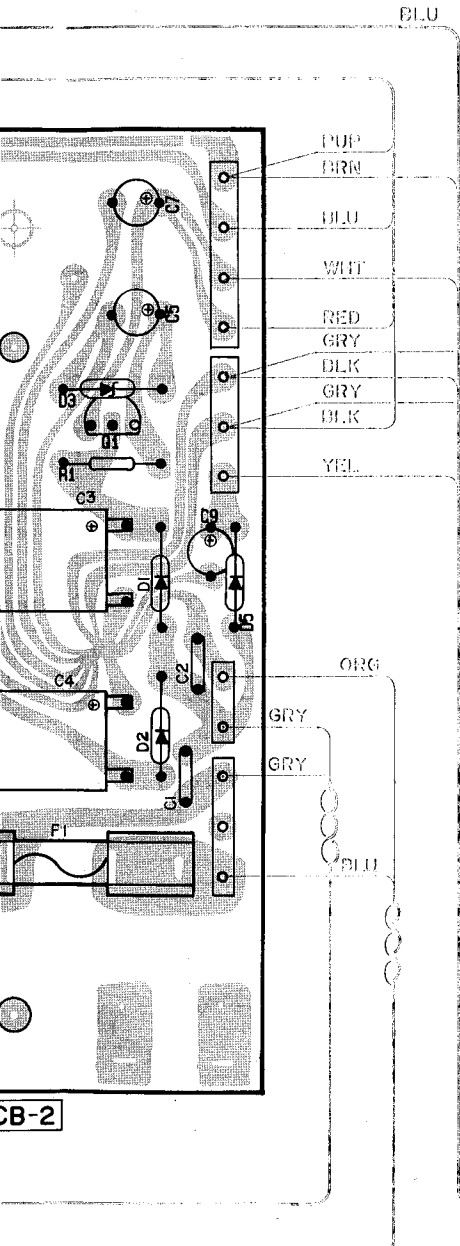

ER

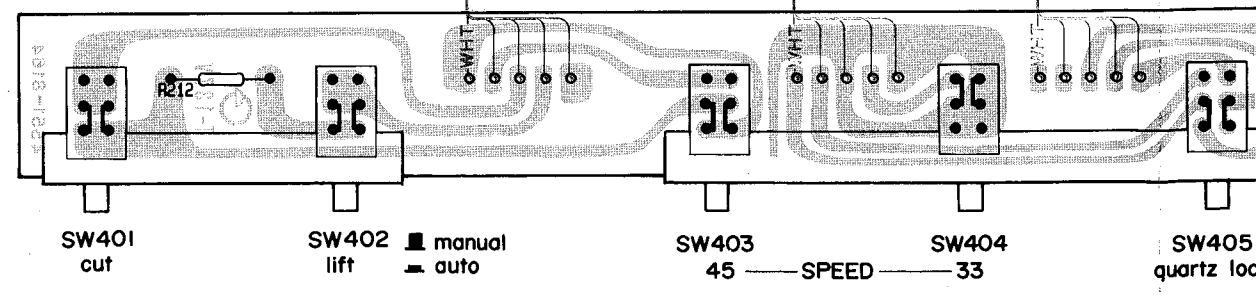

MOYCO ADJUL

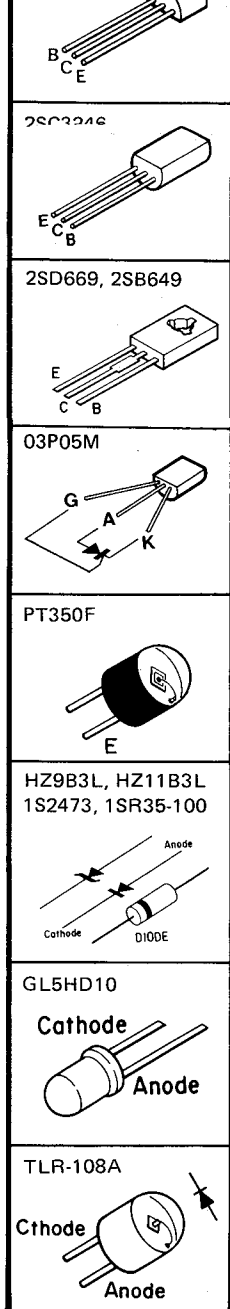
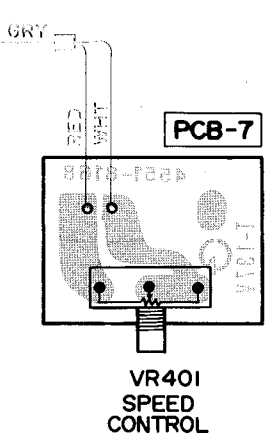
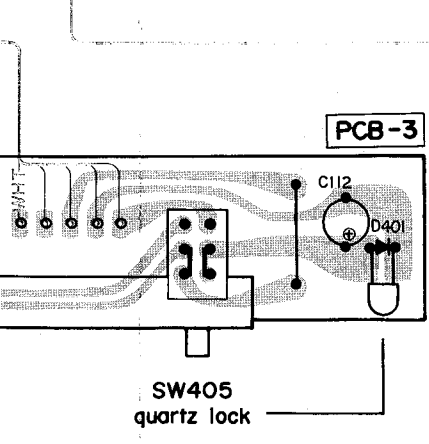
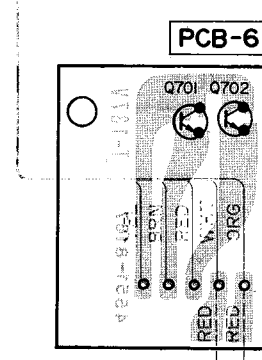
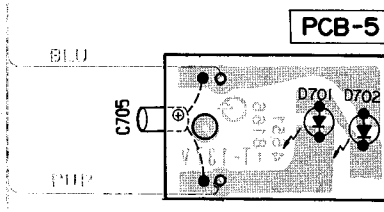
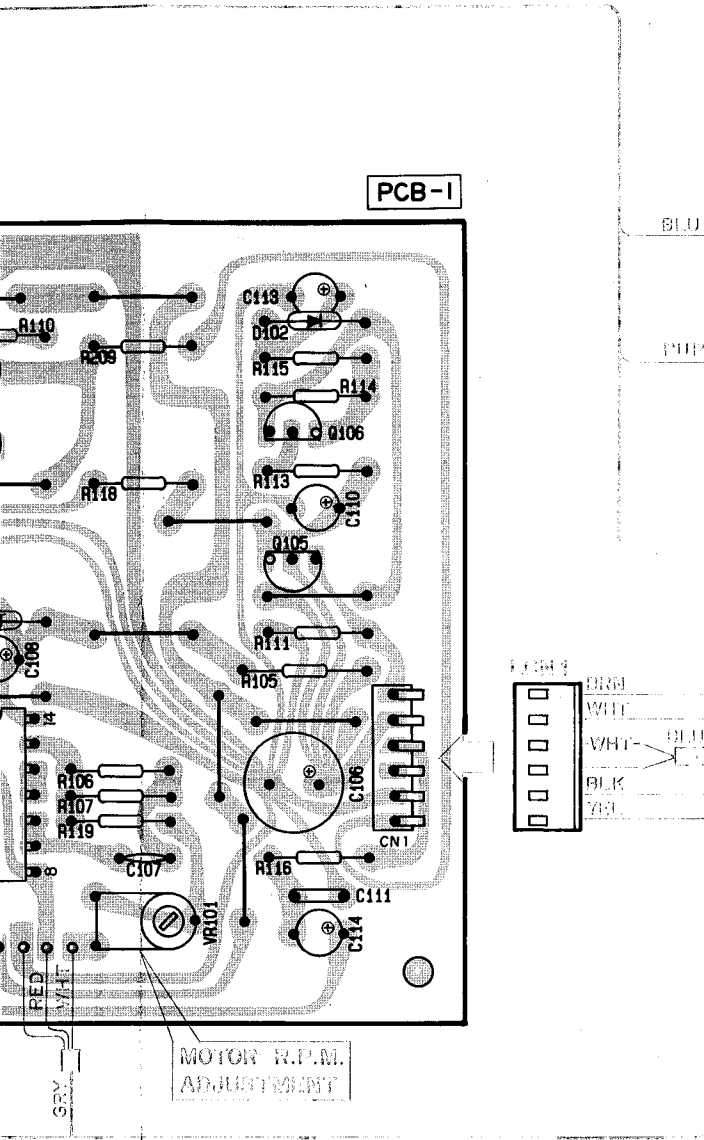
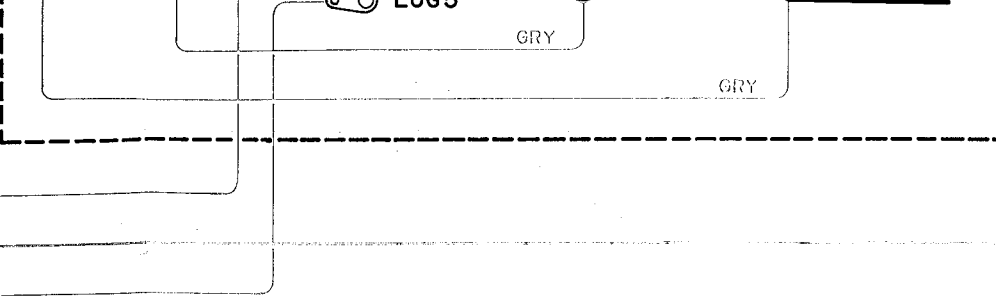

- BLK Black
- BLU Blue
- BRN Brown
- GRN Green
- GRY Gray
- ORG Orange
- PIK Pink
- PUP Purple
- RED Red
- WHT White
- YEL Yellow

