

The Harman Kardon Model TD102/TD202

Manual 108A

ULTRAWIDEBAND LINEAR PHASE CASSETTE DECK

TD102/TD202

Technical Manual

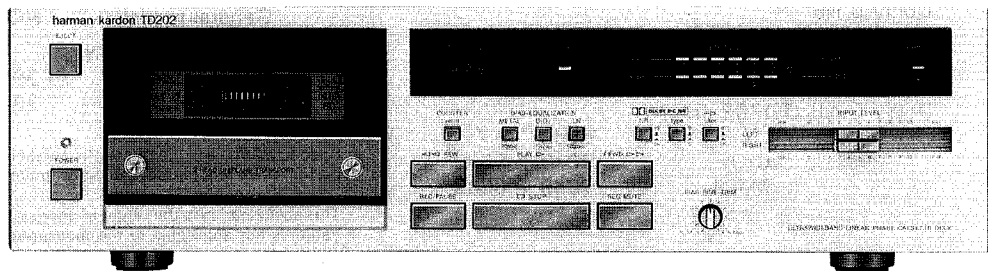

harman/kardon

240 Crossways Park West, Woodbury, N. Y. 11797
1112-3152108A2 P-088610 1500 Printed in Japan

SPECIFICATIONS

	Nominal	Limit
Track Configuration	4-track 2 Channel Stereo Cassette Deck	
Record/Playback Tape Speed	Deviation 4.75 cm/sec. 0.05% \pm 1.5% Drift 4.75 cm/sec. 0.2% \pm 2.0%	
Wow and Flutter	0.05% (NAB) \leq 0.1% 0.2% (CCIR) \leq 0.3%	
Take Up Torque	50gr. cm 35 ~ 70gr. cm	
Back Tension	4gr. cm 2 ~ 6gr. cm	
F. FWD Torque	100gr. cm 70 ~ 150gr. cm	
REW Torque	100gr. cm 70 ~ 150gr. cm	
F. FWD/REW Time (C-60 Tape)	90 sec. \leq 100 sec.	
Motor	Direct Drive motor	
Bias Frequency	105kHz \pm 5kHz	
Playback Output	460mV \pm 1.5dB	
Signal-to-Noise Ratio at Line Input (Input 1kHz, 100mV) IHF-A WTD at Dolby Level Dolby NR Off	LN	51dB
	CrO ₂	54dB
	Metal	54dB
Dolby B NR	LN	61dB
	CrO ₂	64dB \geq 60dB
	Metal	64dB \geq 60dB
Dolby C NR (TD202 only)	LN	66dB
	CrO ₂	70dB \geq 66dB
	Metal	70dB \geq 66dB

	Nominal	Limit
Channel Separation	45dB	\geq 35dB
Crosstalk	70dB	\geq 60dB
Record/Playback Distortion (Input 1kHz)	LN	1.0% \leq 2.0%
	CrO ₂	1.8% \leq 3.0%
	Metal	1.0% \leq 2.0%
MPX Filter Attenuation	at 15kHz	0.3dB \leq 1dB
	at 19kHz	35dB \geq 30dB
Erase Ratio (Input 80Hz)	LN	70dB \geq 60dB
	Metal	61dB \geq 56dB
Input Sensitivity (Input 1kHz) at Line Input	52mV 40(min) ~ 100(max) mV	
Input Impedance (Input 1kHz) at Line Input	23k Ω 19(min) ~ 30(max) k Ω	
DIMENSIONS (WxHxD)	17-1/2" x 4-7/8" x 10-1/2" (443 x 122 x 264 mm)	
WEIGHT	10lbs. (4.5kg)	
POWER SUPPLY	U.S.A. model	AC 120V, 60Hz
	General model	AC 220/240V, 50/60Hz
POWER CONSUMPTION	U.S.A. model	20W
	General model	22W

Specifications and components subject to change without notice. Overall performance will be maintained or improved.

This specification is the target of servicing. But, there is a case that the specification is not applicable to the measurement condition and instrument.

LEAKAGE TEST (FOR SERVICE ENGINEERS IN THE U.S.A.)

Before returning the unit to the user, perform the following safety checks:

- Inspect all lead dress to make certain that leads are not pinched or that hardware is not lodged between the chassis and other metal parts in the unit.
- Be sure that any protective devices such as nonmetallic control knobs, insulating fishpapers, cabinet backs, adjustment and compartment covers or shields, isolation resistor-capacity networks, mechanical insulators, etc. which were removed for servicing are properly reinstalled.
- Be sure that no shock hazard exists; check for leakage current using Simpson Model 229 Leakage Tester, standard equipment item No. 21641, RCA Model WT540A or use alternate method as follows:
Plug the power cord directly into a 120-volt AC receptacle (do not use an Isolation Transformer for this test). Using two clip leads, connect a 1500 Ohm, 10-watt resistor paralleled by a 0.15 μ F capacitor, in series with all exposed metal cabinet parts and a known earth ground, such as a water pipe or conduit. Use a VTVM or VOM with 1000 Ohms per volt, or higher, sensitivity to measure the AC voltage drop across the resistor. (See Diagram.) Move the resistor connection to each exposed metal part having a return path to the chassis (antenna, metal, cabinet, screw heads, knobs and control shafts, escutcheon, etc.) and measure the AC voltage drop across the resistor. (This test should be performed with the power switch in both the On and Off positions.)
A reading of 0.35 volt RMS or more is excessive and indicates a potential shock hazard which must be corrected before returning the unit to the owner.

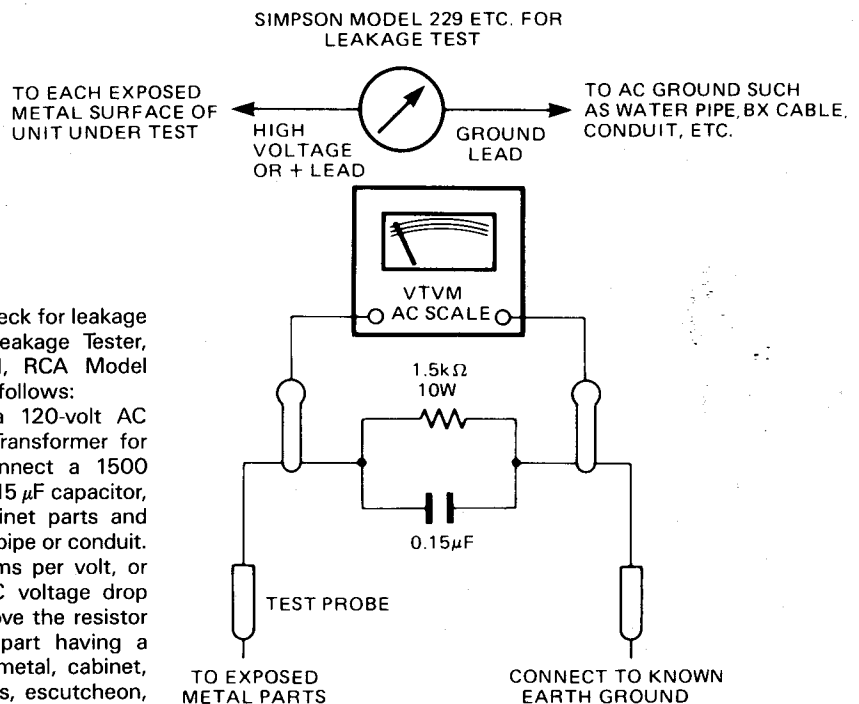

CONTROLS AND FUNCTIONS

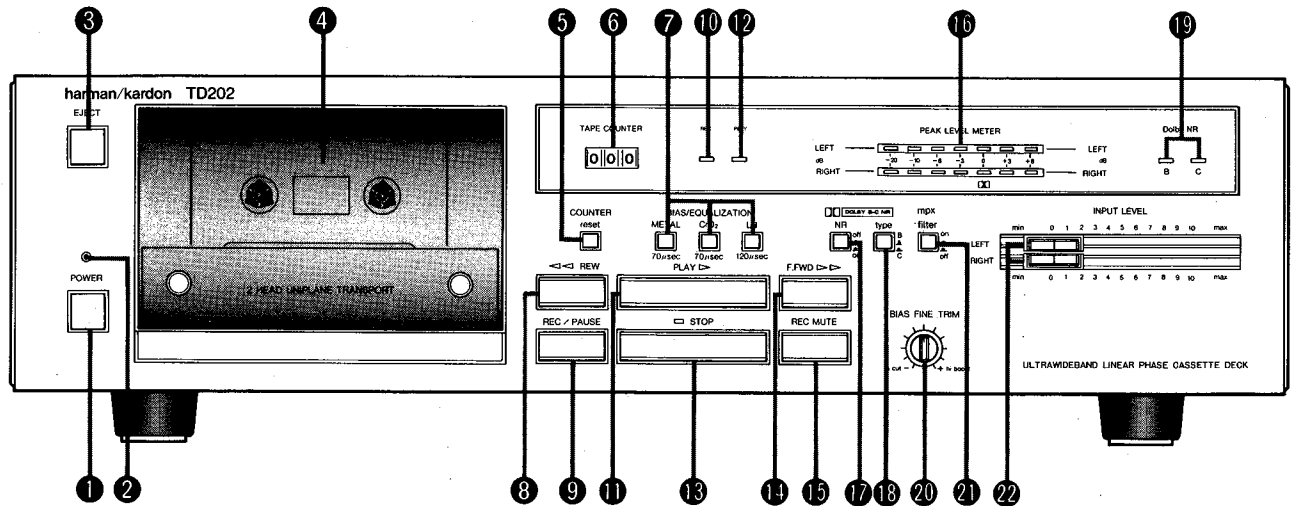

NOTE: The accompanying illustrations show the TD202.

1 POWER SWITCH (POWER)

Pressing this switch will turn on the power and the POWER indicator will light up. Press the switch again to turn the power off.

2 POWER INDICATOR

3 EJECT BUTTON (EJECT)

The soft eject mechanism opens the door slowly when this button is pressed.

CAUTION: This button cannot be depressed while the tape is running. Be sure to press the "STOP" button before pressing the "EJECT" button.

4 CASSETTE COMPARTMENT

5 COUNTER RESET BUTTON (COUNTER reset)

Press this button to reset the "TAPE COUNTER" indication when starting to record.

6 TAPE COUNTER

For a digital indication of the position on a cassette tape. The figure changes as the tape runs. Cueing for the start of a selection is facilitated by making a note of the counter reading.

7 TAPE SELECTORS (BIAS/EQUALIZATION)

For selection of the record and playback circuitry that provides the lowest distortion and flattest frequency response for metal, chromium dioxide (CrO₂) or low noise (LN) tape.

8 REWIND BUTTON (REW)

Press this button to rewind a tape at high speed.

9 RECORD/PAUSE BUTTON (REC/PAUSE)

Press this button to provide the record standby mode. The "REC" indicator will illuminate and the "PLAY" indicator will blink. Recording starts when the "PLAY" button is pressed. The "PLAY" indicator will then stop blinking and remain illuminated. Also, press this button to temporarily stop recording.

10 RECORD INDICATOR

For indication that the tape is being recorded.

① PLAY BUTTON (PLAY)

Press this button to start playback.

② PLAY INDICATOR

For indication that the tape is playing.

③ STOP BUTTON (STOP)

Press this button to stop each operation. Pressing this button stops the playback, recording, fast forward and rewind modes. It also cancels the record standby mode activated by the "REC/PAUSE" button.

④ FAST FORWARD BUTTON (F.FWD)

Press this button to quickly advance the tape in the same direction as it is played.

⑤ RECORD MUTE BUTTON (REC MUTE)

This button allows you to create a silent segment of tape at any time while recording. The button is a momentary contact type and will not lock in the depressed position. The record mute feature will only operate while the button is held in the depressed position.

⑥ PEAK LEVEL METER

The level of the signal being recorded or played is displayed clearly on this meter.

⑦ DOLBY* NR SWITCH (NR)

Depress this switch for recording or playback using the Dolby NR system. The "Dolby NR" indicator will light up. Press the switch again to turn off the Dolby NR system.

⑧ DOLBY NR TYPE SWITCH (type) (TD202 only)

For selection of the Dolby B- or C-type NR system. Depress this switch to select the Dolby C-type NR system. Press it again to select the Dolby B-type system. The green "Dolby NR" indicator (for B-type) or the amber one (for C-type) illuminates according to the "type" switch position.

⑨ DOLBY NR INDICATOR

For indication that Dolby noise reduction circuitry is activated.

⑩ BIAS FINE TRIM KNOB (BIAS FINE TRIM) (TD202 only)

For precise adjustment of the bias used during recording.

⑪ MPX FILTER SWITCH (mpx filter)

The MPX filter is a high frequency filter that has very little effect below 16kHz, but has 30dB attenuation at 19kHz, the frequency of the FM stereo pilot signal. Set this switch to the "on" position when recording from an FM stereo tuner or receiver. However, to appreciate the ultrawideband frequency response of your cassette deck, depress this switch to the "off" position when recording all other sources, such as a turntable, tape deck, etc.

⑫ INPUT LEVEL CONTROL KNOBS (INPUT LEVEL)

These knobs adjust the record level of the input signal. The upper side knob is for the left channel and lower one is for the right channel.

*Dolby noise reduction manufactured under license from Dolby Laboratories Licensing Corporation. "Dolby" and the double-D symbol are trademarks of Dolby Laboratories Licensing Corporation.

DISASSEMBLY PROCEDURES (REFER TO PAGES 15, 23 AND 29)

① CABINET TOP (126) REMOVAL

Remove 6 screws **A** and then remove the Cabinet Top (126).

② FRONT PANEL ASSEMBLY (101) REMOVAL

1. Remove the Cabinet Top (126), referring to the previous step ①.)
2. Pull out the Shaft (194) with the Push Button (147).
3. Remove the Belt (196) of the Tape Counter.
4. Disconnect the connectors (LCN201 and LCN202) connected to the Cassette Tape Recorder Mechanism Assembly (107).
5. Disconnect the connectors (CN1 and CN2) connected to the Main P. C. Board (PCB-1).
6. Remove 6 screws **B** and then remove the Front Panel Assembly (101) with the Cassette Tape Recorder Mechanism Assembly (107).
7. Remove 4 screws **C** and then remove the Cassette Tape Recorder Mechanism Assembly (107).

③ MAIN P. C. BOARD (PCB-1) REMOVAL

1. Remove the Cabinet Top (126), referring to the previous step ①.)
2. Disconnect the connectors (LCN201 and LCN202) connected to the Cassette Tape Recorder Mechanism Assmly (107).
3. Disconnect the connectors (CN1 and CN2) connected to the Main P. C. Board (PCB-1).
4. Open the lid of connectors (CN101 ~CN105, CN107, CN108 and CN110) on the Main P. C. Board (PCB-1) and then disconnect the lead wires.

5. Open the lid of connector (CN109) on the Power Supply P. C. Board (PCB-3) and then disconnect the lead wires.
6. Remove 3 screws **D** and then remove the Main P. C. Board (PCB-1).

④ DISPLAY P. C. BOARD (PCB-2) REMOVAL

1. Remove the Cabinet Top (126), referring to the previous step ①.)
2. Open the lid of connectors (CN101, CN102 and CN105) on the Main P. C. Board (PCB-1) and then disconnect the lead wires.
3. Open the lid of connectors (CN106) on the Function Switches P. C. Board (PCB-5) and then disconnect the lead wires.
4. Remove 3 screws **E** and then remove the Display P. C. Board (PCB-2).

⑤ FUNCTION SWITCHES P. C. BOARD (PCB-5) REMOVAL

1. Remove the Front Panel Assembly (101), referring to the previous step ②.)
2. Pull out the Push Button Assembly (105).
3. Open the lid of connectors (CN103 and CN104) on the Main P. C. Board (PCB-1) and then disconnect the lead wires.
4. Open the lid of connector (CN106) on the Function Switches P. C. Board (PCB-5) and then disconnect the lead wires.
5. Remove 2 screws **F** and then remove the Function Switches P. C. Board (PCB-5).

POWER CORD REPLACEMENT (FOR SERVICE ENGINEERS OTHER THAN NORTH AMERICA)

In order to prevent fire or shock hazard when replacing the power cord, follow the procedure below to replace the part with the standard supply parts.

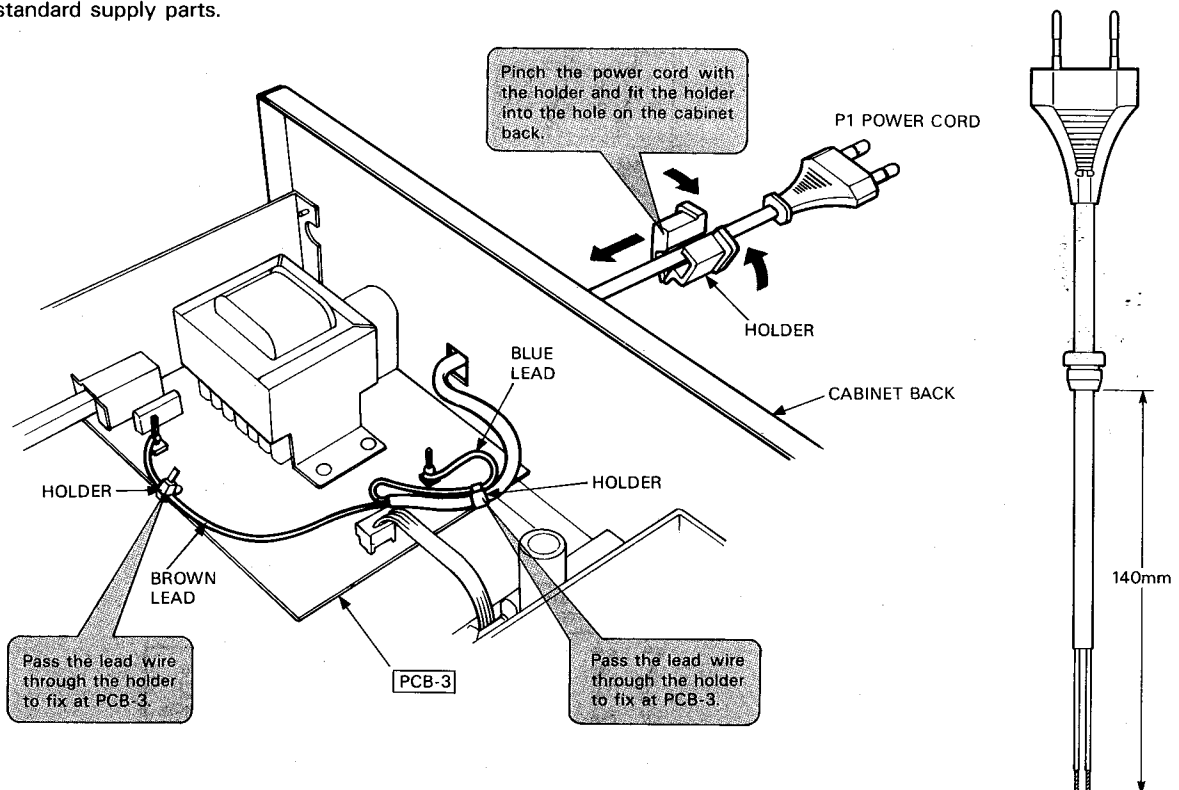

BLOCK DIAGRAM

TD102

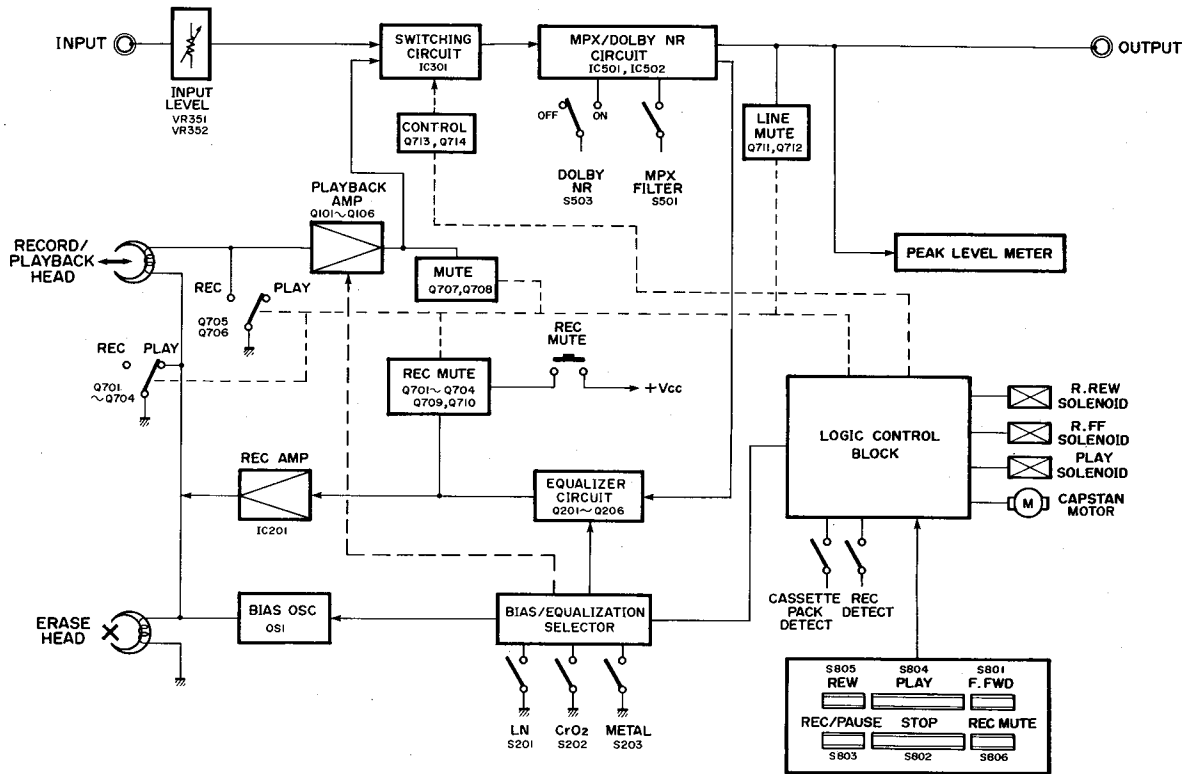

TD202

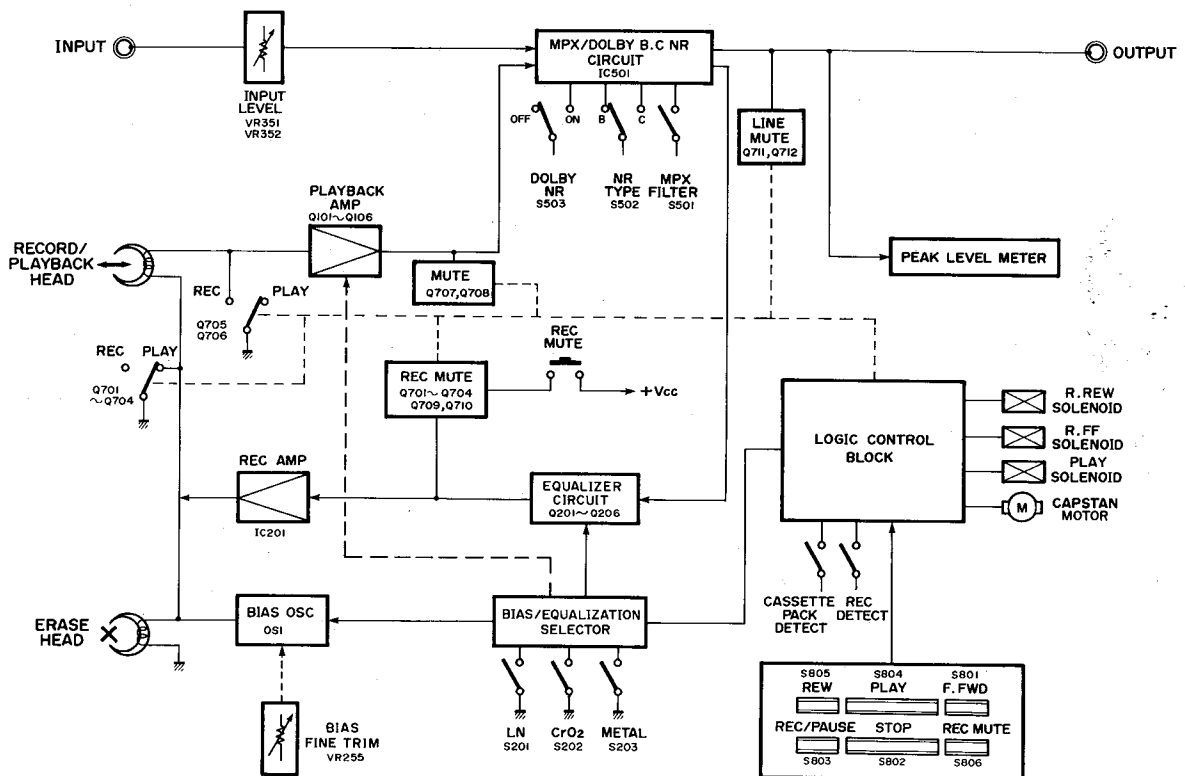

CIRCUIT DESCRIPTION

PLAYBACK SIGNAL (MODEL TD102)

The signal from the playback head is amplified by the playback amplifiers Q101, Q103, Q105 (L ch.) and Q102, Q104, Q106 (R ch.), and is applied to the pins ⑧ (L ch.) and ④ (R ch.) of the switching IC301. Then it is output from the pins ⑨ (L ch.) and ③ (R ch.) of the same IC301 and is applied to the pin ④ of the Dolby NR IC501 (L ch.) and IC502 (R ch.) (B type).

IC301 is usually switched to the playback mode. However, the control signal transmitted from IC801 through Q326 and Q325 switches IC301 from the record mode to the playback mode. Also, this control signal turns ON between the pins ⑧ and ⑨ on the left channel and between pins ③ and ④ on the right channel respectively.

The input signal to the Dolby NR ICs is out from the pin ⑧ of IC501 (L ch.) and IC502 (R ch.), and is applied to the PEAK LEVEL METER circuit consisting of the OUTPUT jack, IC401 (L ch.) and IC402 (R ch.).

The characteristics of the playback equalizer are defined by the BIAS/EQUALIZATION switch and are selected and specified in Q107 (L ch.) and Q108 (R ch.).

RECORD SIGNAL (MODEL TD102)

The signal from the INPUT jack is controlled by the INPUT LEVEL control and is applied to the pins ⑪ (L ch.) and ① (R ch.) of the switching IC301. Then it is output from the pins ⑩ (L ch.) and ② (R ch.) of IC301 and applied to the pin ④ of the Dolby NR IC501 (L ch.) and IC502 (R ch.) (B type). The control signal transmitted from IC801 through Q326 and Q325 switches IC301 from the playback mode to the record mode. Also, this control signal turns ON between pins ⑩ and ⑪ on the left channel and between the pins ① and ② on the right channel of IC301.

The input signal to the Dolby NR ICs is output from the pin ⑤ of the IC501 (L ch.) and IC502 (R ch.) and passes through the MPX filter. Then it is input to the pin ⑥ and is output from the pin ⑨ of IC501 (L ch.) and IC502 (R ch.). The output signal from the Dolby NR ICs passes through the record equalizer circuit and is amplified by the record amplifier. The amplified signal is then applied to the recording head after being synthesized by a bias signal.

PLAYBACK SIGNAL (MODEL TD202)

The signal from the playback head is amplified by the playback amplifiers Q101, Q103, Q105 (L ch.), and Q102, Q104, Q106 (R ch.), and is applied to the pins ③ (L ch.) and ⑳ (R ch.) of the Dolby NR IC501 (B/C type). Switching of the playback signal from the record mode (external input signal) to the playback mode is performed inside IC501.

IC501 is usually switched to the playback mode. However, the control signal transmitted to the pin ⑳ of IC501 from IC801 through Q507 and Q508 switches IC501 from the record mode to the playback mode. The input signal to IC501 is output from the pins ⑨ (L ch.) and ⑳ (R ch.) and applied to the OUTPUT jack and the PEAK LEVEL METER circuit.

The characteristics of the playback equalizer are defined by the BIAS/EQUALIZATION switch and are selected and specified in Q107 (L ch.) and Q108 (R ch.).

RECORD SIGNAL (MODEL TD202)

The signal from the INPUT jack is controlled by the INPUT LEVEL control and is applied to pins ③ (L ch.) and ⑳ (R ch.) of the Dolby NR IC501 (B/C type). Switching of the record signal from the playback mode to the record mode is performed inside IC501.

The control signal transmitted to the pin ⑳ of IC501 from IC801 through Q507 and Q508 switches IC501 from the playback mode to the record mode.

The input signal to the Dolby NR IC is output from pins ⑥ (L ch.) and ⑳ (R ch.) of IC501 and passes through the MPX filter. Then it is input to the pins ⑦ (L ch.) and ⑳ (R ch.) and is output from the pins ⑳ (L ch.) and ⑳ (R ch.).

The signal output from IC501 passes through the record equalizer circuit and is amplified by the record amplifier of IC201. The amplified signal is then applied to the recording head after being synthesized by a bias signal.

LOGIC IN RECORD MODE (TD102)

When the "REC" button is pressed, the pin ②④ of IC801 becomes high level and Q705 (L ch.) and Q706 (R ch.) turn ON. The input to the playback amplifiers is muted. Also Q803 and Q805 turn ON and Q808 turns OFF. Therefore Q701, Q703 (L ch.) and Q702, Q704 (R ch.) turn OFF to release the muting of the outputs from the record amplifiers. Also Q505 turns ON to make the pin ⑦ of IC501 (L ch.) and IC502 (R ch.) low level. Therefore the mode is switched to the record mode.

LOGIC IN RECORD MODE (TD202)

When the "REC" button is pressed, the pin ②④ of IC801 becomes high level and Q705 (L ch.) and Q706 (R ch.) turn ON. The input to the playback amplifiers is muted. Also Q803 and Q805 turn ON and Q808 turns OFF. Therefore Q701, Q703 (L ch.) and Q702, Q704 (R ch.) turn OFF to release the muting of the outputs from the record amplifiers. Also, Q507 turns ON and Q508 turns OFF to make the pin ③⑧ of IC501 high level. Therefore the mode is switched to the record mode.

MUTING (MODELS TD102 AND TD202)

The signal that mutes the sound produced at switching to recording or playback is applied from IC801 of the logic control block.

When the "STOP" button is pressed, the mute signal output from the pin ②⑥ of IC801 turns ON Q707 (L ch.) and Q708 (R ch.) to short-circuit the output signals of the playback amplifiers for muting. Also, this mute signal turns ON Q713 and Q714 as well as Q711 (L ch.) and Q712 (R ch.) to mute the output line signal from the Dolby NR ICs.

For the purpose of preventing generation of noise at power ON/OFF, the mute signal is output from Q51. The muting is done by short circuiting the output signal with Q711 (L ch.) and Q712 (R ch.) turned ON.

SWITCHING FROM RECORD MODE TO PLAYBACK MODE IN LOGIC (TD102)

When the "STOP", "PAUSE" or "PLAY" button is pressed, the pin ②④ of IC801 becomes low level. Q705 (L ch.) and Q706 (R ch.) turn OFF to release the muting of the inputs to the playback amplifiers. Also, Q803 and Q805 turn OFF and Q808 turns ON to turn ON Q701, Q703 (L ch.) and Q704 (R ch.). Therefore the outputs from the record amplifiers are muted.

Also Q505 turns OFF to make the pin ⑦ of IC501 (L ch.) and IC502 (R ch.) high level. Therefore the mode is switched to the playback mode.

SWITCHING FROM RECORD MODE TO PLAYBACK MODE IN LOGIC (TD202)

When the "STOP", "PAUSE" or "PLAY" button is pressed, the pin ②④ of IC801 becomes low level. Q705 (L ch.) and Q706 (R ch.) turn OFF to release the muting of the inputs to the playback amplifiers. Also, Q803 and Q805 turn OFF and Q808 turns ON to turn ON Q701, Q703 (L ch.) and Q702, Q704 (R ch.). Therefore the outputs from the record amplifiers are muted.

Also, Q507 turns OFF and Q508 turns ON to make the pin ③⑧ of IC501 low level. Therefore the mode is switched to the playback mode.

ALIGNMENT PROCEDURES (REFER TO PAGES 24, 25, 27 AND 28 FOR TD102 OR 30, 31, 33 AND 34 FOR TD202)

■ CASSETTE MECHANISM CONFIRMATION

Make sure to confirm conditions of the cassette mechanism as follows before adjustment.

1. Confirmation of erroneous erase preventive function

- The switch should turn ON when a tape with erroneous erase preventive pawl is inserted. (Use a tape which is 0.2mm smaller than the minimum size of 62.9mm or a MAZ-0184-C gauge one.)
- When the switch arm is moved back gradually from the ON position, the switch should turn OFF.

2. Confirmation of cassette pack detection function

- The switch should turn ON when a tape is inserted. (Use a tape whose minimum size is 63.5mm or a MAZ-0184-C gauge one.)
- When the switch arm is moved back gradually from the ON position, the switch should turn OFF.

3. Confirmation of eject function

- The cassette compartment opens smoothly and no abnormal noise should be heard while opening and closing.
- The eject lock arm opens smoothly without contacting the chassis and damper.
- The eject button can not be pressed during playback.

4. Confirmation of playback, fast forward and rewind functions

- The torque used in each of the playback, fast forward and rewind modes should be within specification.
 Playback 35gr. cm ~ 70gr. cm
 Fast Forward 70gr. cm ~ 150gr. cm
 Rewind 70gr. cm ~ 150gr. cm
- No abnormal noise should be heard during operation in any mode. The solenoid switching sound should not be considered as a noise.

5. Confirmation of positions of record/playback head and erase head

● Head height

- Set the M-300 head gauge.
- Set the unit in the playback mode and place the adjustment chip on the head gauge as shown in the Fig. 1.
- The adjustment chip should not contact the tape guide of both record/playback head and erase head.

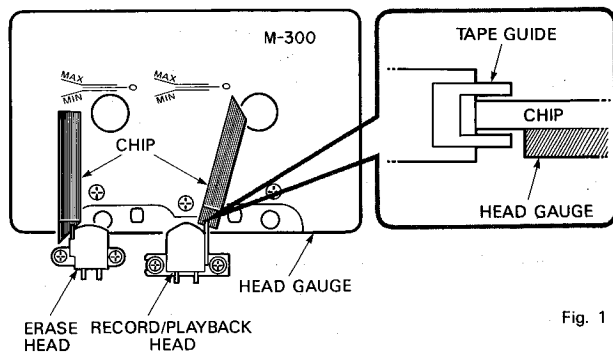

Fig. 1

● Head position

- Set the M-300 head gauge.
- Set the unit in the playback mode and place the adjustment chip on the head gauge as shown in the Fig. 2.
- With both record/playback head and erase head, the adjustment chip should be between MIN and MAX of the M-300 head gauge.

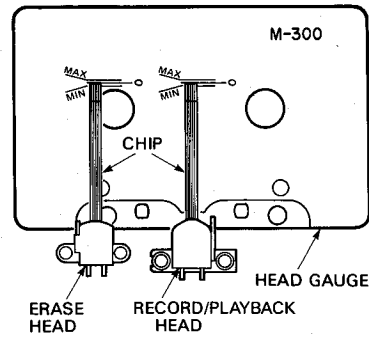

Fig. 2

■ ELECTRICAL ADJUSTMENT AND CONFIRMATION

1. Before adjustment

- Before electrical adjustment, make sure that confirmations of the cassette mechanism are all completed.
- After the power switch is pushed on, wait for 10 minutes before measuring to be sure of the most stable operation.
- Since head magnetization, dust accumulations, etc. are likely to introduce errors in the various characteristics, it is very important that the heads are properly demagnetized and cleaned before commencing any adjustment, particularly frequency response and head azimuth adjustment.

2. Instruments required

- Low frequency oscillator
- AC VTVM or dual channel AC VTVM
- Oscilloscope
- Wow/flutter meter
- Frequency counter

3. Test tapes

- Azimuth adjustment MTT-114
- Tape speed adjustment MTT-111 or MTT-111D
- Playback output level adjustment MTT-150 or TCC-130
- Playback frequency characteristic confirmation TCC-162C, TCC-262C
- Reference tapes
 LN SCC-502
 CrO₂ SCC-504
 METAL SCC-565

Note:

C-90 differs with C-60 in the thickness and bias is of unequal, so adjust with the tape whose bias in of specified value.

4. General conditions (unless otherwise noted)

Controls and Switches	Settings
Dolby NR	Off
Input Level	Maximum
MPX Filter	Off
Bias Fine Trim (TD202 only)	Center

Azimuth Adjustment

When the maximum level point of R channel does not equal that L channel, connect the oscilloscope as shown in Fig. 3 and proceed with azimuth adjustment so that L and R channels are in phase.

- Connect L channel tape out to "X (or V)" and R channel to "Y (or H)". Observe the lissajous waveform.
- Set L and R channels to monaural. Adjust vertical and horizontal gain so that the waveform becomes 45 degree.
- Adjust azimuth so that the measurement of "a" becomes maximum and the measurement of "b" becomes minimum against the 45 degree line.

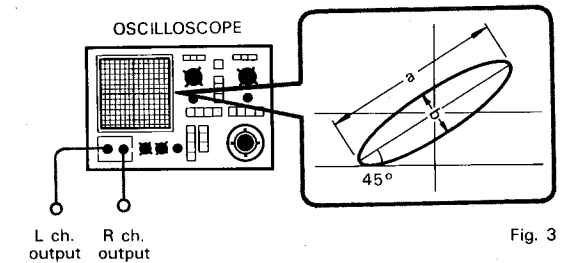
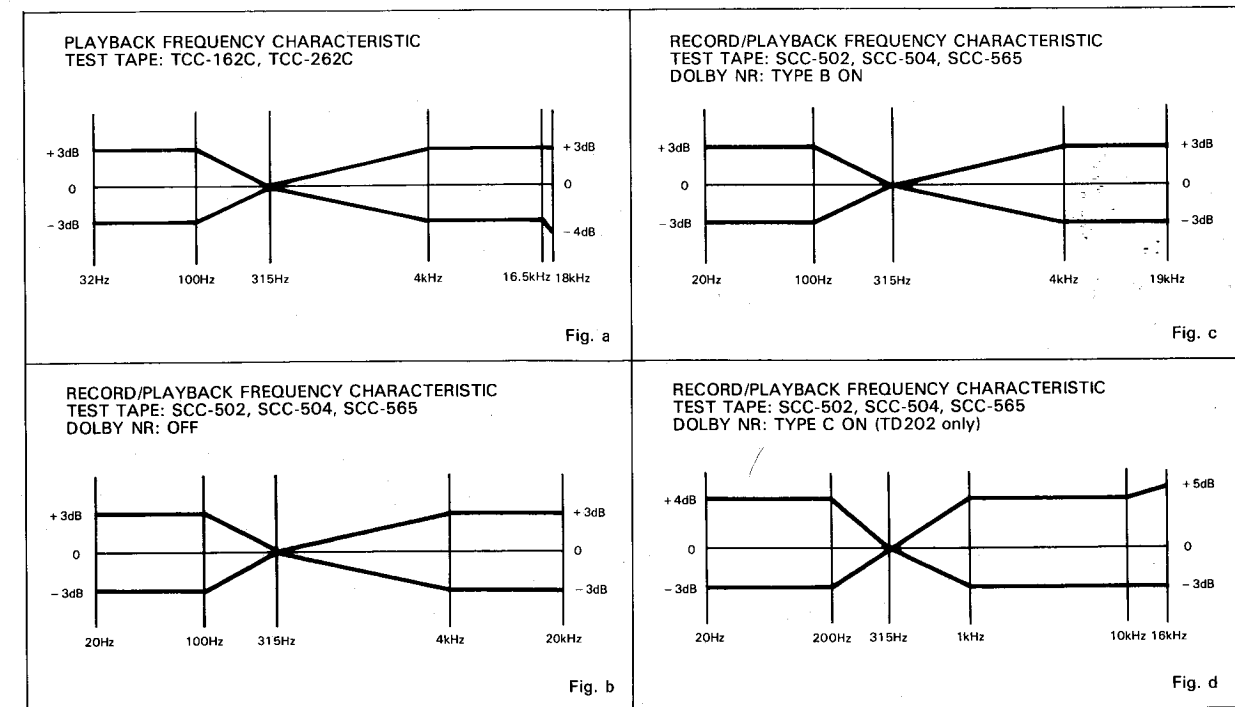

Fig. 3



ALIGNMENT PROCEDURES (REFER TO PAGES 24, 25, 27 AND 28 FOR TD102 OR 30, 31, 33 AND 34 FOR TD202)

■ **CASSETTE MECHANISM CONFIRMATION**

Make sure to confirm conditions of the cassette mechanism as follows before adjustment.

1. Confirmation of erroneous erase preventive function

- The switch should turn ON when a tape with erroneous erase preventive pawl is inserted. (Use a tape which is 0.2mm smaller than the minimum size of 62.9mm or a MAZ-0184-C gauge one.)
- When the switch arm is moved back gradually from the ON position, the switch should turn OFF.

2. Confirmation of cassette pack detection function

- The switch should turn ON when a tape is inserted. (Use a tape whose minimum size is 63.5mm or a MAZ-0184-C gauge one.)
- When the switch arm is moved back gradually from the ON position, the switch should turn OFF.

3. Confirmation of eject function

- The cassette compartment opens smoothly and no abnormal noise should be heard while opening and closing.
- The eject lock arm opens smoothly without contacting the chassis and damper.
- The eject button can not be pressed during playback.

4. Confirmation of playback, fast forward and rewind functions

- The torque used in each of the playback, fast forward and rewind modes should be within specification.

Playback	35gr. cm ~ 70gr. cm
Fast Forward	70gr. cm ~ 150gr. cm
Rewind	70gr. cm ~ 150gr. cm
- No abnormal noise should be heard during operation in any mode. The solenoid switching sound should not be considered as a noise.

5. Confirmation of positions of record/playback head and erase head

● **Head height**

- a) Set the M-300 head gauge.
- b) Set the unit in the playback mode and place the adjustment chip on the head gauge as shown in the Fig. 1.
- c) The adjustment chip should not contact the tape guide of both record/playback head and erase head.

● **Head position**

- a) Set the M-300 head gauge.
- b) Set the unit in the playback mode and place the adjustment chip on the head gauge as shown in the Fig. 2.
- c) With both record/playback head and erase head, the adjustment chip should be between MIN and MAX of the M-300 head gauge.

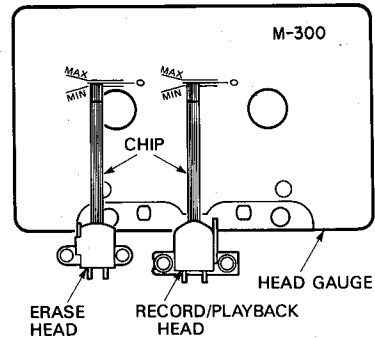

Fig. 2

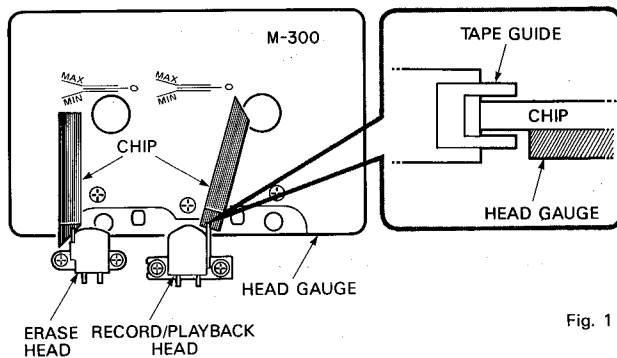

Fig. 1

■ ELECTRICAL ADJUSTMENT AND CONFIRMATION

1. Before adjustment

- Before electrical adjustment, make sure that confirmations of the cassette mechanism are all completed.
- After the power switch is pushed on, wait for 10 minutes before measuring to be sure of the most stable operation.
- Since head magnetization, dust accumulations, etc. are likely to introduce errors in the various characteristics, it is very important that the heads are properly demagnetized and cleaned before commencing any adjustment, particularly frequency response and head azimuth adjustment.

2. Instruments required

- Low frequency oscillator
- AC VTVM or dual channel AC VTVM
- Oscilloscope
- Wow/flutter meter
- Frequency counter

3. Test tapes

- Azimuth adjustment MTT-114
- Tape speed adjustment MTT-111 or MTT-111D
- Playback output level adjustment MTT-150 or TCC-130
- Playback frequency characteristic confirmation TCC-162C, TCC-262C
- Reference tapes
 - LN SCC-502
 - CrO₂ SCC-504
 - METAL SCC-565

Note:

C-90 differs with C-60 in the thickness and bias is of unequal, so adjust with the tape whose bias is of specified value.

4. General conditions (unless otherwise noted)

Controls and Switches	Settings
Dolby NR	Off
Input Level	Maximum
MPX Filter	Off
Bias Fine Trim (TD202 only)	Center

Azimuth Adjustment

When the maximum level point of R channel does not equal that L channel, connect the oscilloscope as shown in Fig. 3 and proceed with azimuth adjustment so that L and R channels are in phase.

- Connect L channel tape out to "X (or V)" and R channel to "Y (or H)". Observe the lissajous waveform.
- Set L and R channels to monaural. Adjust vertical and horizontal gain so that the waveform becomes 45 degree.
- Adjust azimuth so that the measurement of "a" becomes maximum and the measurement of "b" becomes minimum against the 45 degree line.

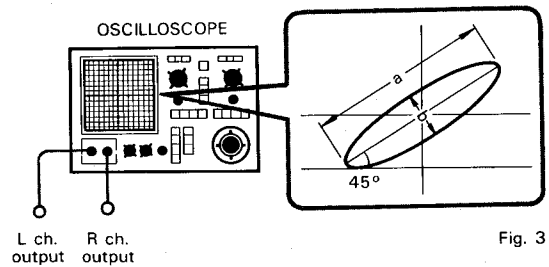
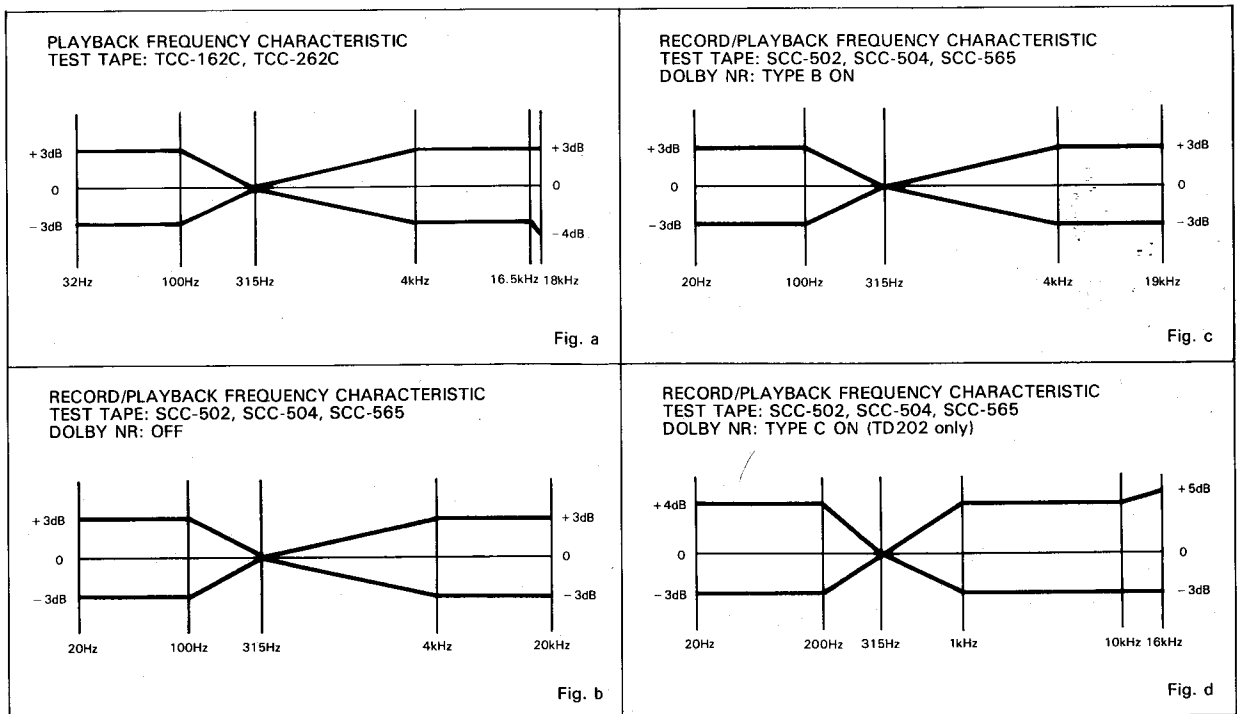

Fig. 3



Step	Alignment	Instrument Require	Input Signal	Mode	Test Point	Adjustment	For
1	Azimuth	VTVM Oscilloscope Test tape (MTT-114)		PB	TP1 TP2	Azimuth screw	Maximum output Refer to "Azimuth Adjustment" on page 9.
2	Tape speed	Frequency counter Test tape (MTT-111 or MTT-111D)		PB	TP1 TP2	VR (built-in motor)	3000Hz \pm 10Hz Adjust at the center of test tape
3	Playback output level	VTVM Test tape (MTT-150 or TCC-130)		PB	TP1 TP2	VR101 VR102	580mV (TD102)/300mV (TD202)
4	Playback frequency characteristic	VTVM Test tape (TCC-162 and TCC-262C)		PB	OUTPUT jack	VR103 VR104	So that the frequency response is -1dB ~ -2dB (TD102)/ 0.5dB ~ -1.5dB (TD202).
5	Bias trap	VTVM		REC/PB	TP3 TP4	L203 L204	Minimum output
6	Bias level (pre-adjustment)	VTVM		REC/PB	TP5 TP6	VR253 VR254	75mV (TD102)/65mV (TD202) Tape selector is METAL position.
					TP5 TP6	VR251	45mV Tape selector is CrO2 position.
					TP5 TP6	VR252	25mV (TD102)/27mV (TD202) Tape selector is LN position.
7	Bias frequency confirmation	Frequency counter		REC/PB	TP5		105kHz \pm 5kHz Tape selector is METAL position.
8	Record level (pre-adjustment)	VTVM Blank tape (SCC-504)	Apply 400Hz signal to INPUT jack. Set INPUT LEVEL knob so that TP1 (TD102)/TP7 (TD202) and TP2 (TD102)/TP8 (TD202) voltage is 580mV (TD102)/300mV (TD202) in REC-PAUSE mode.	REC/PB	TP1 TP2	VR201 VR202	580mV (TD102)/300mV (TD202) Tape selector is CrO2 position.
9	Peaking coil (pre-adjustment)	VTVM Blank tape (SCC-565)	Apply 400Hz signal to INPUT jack. Set INPUT LEVEL knob so that TP1 (TD102)/TP7 (TD202) and TP2 (TD102)/TP8 (TD202) voltage is 580mV (TD102)/300mV (TD202) - 25dB in REC mode.	REC/PB	TP5 TP6	L201 L202	So that output becomes maximum at 20kHz input. Remove the R252 (TD102 only). Open the lid of connector (CN110) and then disconnect the lead wires (TD202 only). Tape selector is METAL position.
10	Record/playback equalizer frequency characteristic (pre-adjustment)	VTVM Blank tape (SCC-565)	Apply 400Hz signal to INPUT jack. Set INPUT LEVEL knob so that TP1 (TD102)/TP7 (TD202) and TP2 (TD102)/TP8 (TD202) voltage is 580mV (TD102)/300mV (TD202) - 25dB in REC-PAUSE mode. Then adjust with a 20Hz to 30kHz sweep signal.	REC/PB	OUTPUT jack	VR253 VR254	So that the record/playback frequency response is flat (at least within the range in Fig. b). Tape selector is METAL position.
11	Record/playback equalizer frequency characteristic	VTVM Blank tapes (Metal SCC-565) (CrO2 SCC-504) (LN SCC-502)	Apply 400Hz signal to INPUT jack. Set INPUT LEVEL knob so that TP1 (TD102)/TP7 (TD202) and TP2 (TD102)/TP8 (TD202) voltage is 580mV (TD102)/300mV (TD202) - 25dB in REC-PAUSE mode. Then adjust with a 20Hz to 30kHz sweep signal.	REC/PB	OUTPUT jack	VR251,L202 VR253,L201	So that the record/playback frequency response is flat (at least within the range in Fig. b). Tape selector is CrO2 position.
						VR252	So that the record/playback frequency response is flat (at least within the range in Fig. b). Tape selector is LN position.
						check	Tape selector is METAL position.
						VR253	Tape selector is LN position. So that the record/playback frequency response of L ch. at METAL position and that of L ch. at LN position are balanced.
12	Record level	VTVM Blank tape (SCC-504)	Apply 400Hz signal to INPUT jack. Set INPUT LEVEL knob so that TP1 (TD102)/TP7 (TD202) and TP2 (TD102)/TP8 (TD202) voltage is 580mV (TD102)/300mV (TD202) in REC-PAUSE mode.	REC/PB	TP1 TP2	VR201 VR202	580mV (TD102)/300mV (TD202) Tape selector is CrO2 position.
13	Record level	VTVM Blank tapes (Metal SCC-565) (LN SCC-502)	Apply 400Hz signal to INPUT jack. Set INPUT LEVEL knob so that TP1 (TD102)/TP7 (TD202) and TP2 (TD102)/TP8 (TD202) voltage is 580mV (TD102)/300mV (TD202) in REC-PAUSE mode.	REC/PB	TP1 TP2		580mV \pm 1dB (TD102)/300mV \pm 1dB (TD202) This confirmation should be done at each tape selector position.
14	Record/playback equalizer frequency characteristic confirmation	VTVM Blank tapes (Metal SCC-565) (CrO2 SCC-504) (LN SCC-502)	Apply 400Hz signal to INPUT jack. Set INPUT LEVEL knob so that TP1 (TD102)/TP7 (TD202) and TP2 (TD102)/TP8 (TD202) voltage is 580mV (TD102)/300mV (TD202) - 25dB in REC-PAUSE mode. Then adjust with a 20Hz to 30kHz sweep signal.	REC/PB	OUTPUT jack		Confirm that the record/playback frequency response is within the range in Fig. c and Fig. d. If it is not within the specification, redo the adjustment and confirmation in steps 10, 11 and 12. This confirmation should be done at each tape selector position under each of the following conditions. Dolby B NR on and Dolby C NR on.
15	Meter level	VTVM	Apply 400Hz signal to INPUT jack. Set INPUT LEVEL knob so that TP1 (TD102)/TP7 (TD202) and TP2 (TD102)/TP8 (TD202) voltage is 580mV (TD102)/300mV (TD202) - 0.5dB in REC-PAUSE mode.	REC-PAUSE	PEAK LEVEL METER	VR401 VR402	Adjust to the point where the 0dB of the PEAK LEVEL METER lights.
16	MPX filter characteristic confirmation	VTVM	Apply 19kHz and 15kHz signal to INPUT jack. Set INPUT LEVEL knob so that TP1 (TD102)/TP7 (TD202) and TP2 (TD102)/TP8 (TD202) voltage is 580mV (TD102)/300mV (TD202) in REC-PAUSE mode.	REC-PAUSE	OUTPUT jack		Confirm that attenuation of 15kHz and 19kHz is within the specification when MPX FILTER on.
17	Anti-skewing level confirmation (TD202 only)	VTVM	Apply 400Hz signal to INPUT jack. Set INPUT LEVEL knob so that TP7 and TP8 voltage is 300mV - 25dB in REC-PAUSE mode.	REC-PAUSE	TP201 TP202		Confirm that attenuation of 20kHz is maximum. Dolby C NR is on.

Step	Alignment	Instrument Require	Input Signal	
1	Azimuth	VTVM Oscilloscope Test tape (MTT-114)		
2	Tape speed	Frequency counter Test tape (MTT-111 or MTT-111D)		
3	Playback output level	VTVM Test tape (MTT-150 or TCC-130)		
4	Playback frequency characteristic	VTVM Test tape (TCC-162 and TCC-262C)		
5	Bias trap	VTVM		
6	Bias level (pre-adjustment)	VTVM		
				1
				2
3				
7	Bias frequency confirmation	Frequency counter		
8	Record level (pre-adjustment)	VTVM Blank tape (SCC-504)	Apply 400Hz signal to INPUT jack. Set INPUT LEVEL knob so TP1 (TD102)/TP7 (TD202) and TP2 (TD102)/TP8 (TD202) voltage is 580mV (TD102)/300mV (TD202) in REC-PAUSE mode.	
9	Peaking coil (pre-adjustment)	VTVM Blank tape (SCC-565)	Apply 400Hz signal to INPUT jack. Set INPUT LEVEL knob so TP1 (TD102)/TP7 (TD202) and TP2 (TD102)/TP8 (TD202) voltage is 580mV (TD102)/300mV (TD202) - 25dB in REC mode.	
10	Record/playback equalizer frequency characteristic (pre-adjustment)	VTVM Blank tape (SCC-565)	Apply 400Hz signal to INPUT jack. Set INPUT LEVEL knob so TP1 (TD102)/TP7 (TD202) and TP2 (TD102)/TP8 (TD202) voltage is 580mV (TD102)/300mV (TD202) - 25dB in REC-PAUSE mode. Then adjust with a 20Hz to 30kHz sweep signal.	
11	Record/playback equalizer frequency characteristic	VTVM Blank tapes (Metal SCC-565) (CrO ₂ SCC-504) (LN SCC-502)	Apply 400Hz signal to INPUT jack. Set INPUT LEVEL knob so TP1 (TD102)/TP7 (TD202) and TP2 (TD102)/TP8 (TD202) voltage is 580mV (TD102)/300mV (TD202) - 25dB in REC-PAUSE mode. Then adjust with a 20Hz to 30kHz sweep signal.	
				1
				2
				3
4				
12	Record level	VTVM Blank tape (SCC-504)	Apply 400Hz signal to INPUT jack. Set INPUT LEVEL knob so TP1 (TD102)/TP7 (TD202) and TP2 (TD102)/TP8 (TD202) voltage is 580mV (TD102)/300mV (TD202) in REC-PAUSE mode.	
13	Record level	VTVM Blank tapes (Metal SCC-565) (LN SCC-502)	Apply 400Hz signal to INPUT jack. Set INPUT LEVEL knob so TP1 (TD102)/TP7 (TD202) and TP2 (TD102)/TP8 (TD202) voltage is 580mV (TD102)/300mV (TD202) in REC-PAUSE mode.	
14	Record/playback equalizer frequency characteristic confirmation	VTVM Blank tapes (Metal SCC-565) (CrO ₂ SCC-504) (LN SCC-502)	Apply 400Hz signal to INPUT jack. Set INPUT LEVEL knob so TP1 (TD102)/TP7 (TD202) and TP2 (TD102)/TP8 (TD202) voltage is 580mV (TD102)/300mV (TD202) - 25dB in REC-PAUSE mode. Then adjust with a 20Hz to 30kHz sweep signal.	
15	Meter level	VTVM	Apply 400Hz signal to INPUT jack. Set INPUT LEVEL knob so TP1 (TD102)/TP7 (TD202) and TP2 (TD102)/TP8 (TD202) voltage is 580mV (TD102)/300mV (TD202) - 0.5dB in REC-PAUSE mode.	
16	MPX filter characteristic confirmation	VTVM	Apply 19kHz and 15kHz signal to INPUT jack. Set INPUT LEVEL knob so that TP1 (TD102)/TP7 (TD202) and TP2 (TD102)/TP8 (TD202) voltage is 580mV (TD102)/300mV (TD202) in REC-PAUSE mode.	
17	Anti-skewing level confirmation (TD202 only)	VTVM	Apply 400Hz signal to INPUT jack. Set INPUT LEVEL knob so TP7 and TP8 voltage is 300mV - 25dB in REC-PAUSE mode.	

	Mode	Test Point	Adjustment	For
	PB	TP1 TP2	Azimuth screw	Maximum output Refer to "Azimuth Adjustment" on page 9.
	PB	TP1 TP2	VR (built-in motor)	3000Hz \pm 10Hz Adjust at the center of test tape
	PB	TP1 TP2	VR101 VR102	580mV (TD102)/300mV (TD202)
	PB	OUTPUT jack	VR103 VR104	So that the frequency response is -1dB ~ -2dB (TD102)/ 0.5dB ~ -1.5dB (TD202).
	REC/PB	TP3 TP4	L203 L204	Minimum output
	REC/PB	TP5 TP6	VR253 VR254	75mV (TD102)/65mV (TD202) Tape selector is METAL position.
		TP5 TP6	VR251	45mV Tape selector is CrO2 position.
		TP5 TP6	VR252	25mV (TD102)/27mV (TD202) Tape selector is LN position.
	REC/PB	TP5		105kHz \pm 5kHz Tape selector is METAL position.
knob so that (2) voltage is	REC/PB	TP1 TP2	VR201 VR202	580mV (TD102)/300mV (TD202) Tape selector is CrO2 position.
knob so that (2) voltage is	REC/PB	TP5 TP6	L201 L202	So that output becomes maximum at 20kHz input. Remove the R252 (TD102 only). Open the lid of connector (CN110) and then disconnect the lead wires (TD202 only). Tape selector is METAL position.
knob so that (2) voltage is E mode.	REC/PB	OUTPUT jack	VR253 VR254	So that the record/playback frequency response is flat (at least within the range in Fig. b). Tape selector is METAL position.
knob so that (2) voltage is E mode.	REC/PB	OUTPUT jack	VR251,L202	So that the record/playback frequency response is flat (at least within the range in Fig. b). Tape selector is CrO2 position.
			VR253,L201	
			VR252	So that the record/playback frequency response is flat (at least within the range in Fig. b). Tape selector is LN position.
			check	Tape selector is METAL position.
			VR253	Tape selector is LN position. So that the record/playback frequency response of L ch. at METAL position and that of L ch. at LN position are balanced.
knob so that (2) voltage is	REC/PB	TP1 TP2	VR201 VR202	580mV (TD102)/300mV (TD202) Tape selector is CrO2 position.
knob so that (2) voltage is	REC/PB	TP1 TP2		580mV \pm 1dB (TD102)/300mV \pm 1dB (TD202) This confirmation should be done at each tape selector position.
knob so that (2) voltage is E mode.	REC/PB	OUTPUT jack		Confirm that the record/playback frequency response is within the range in Fig. c and Fig. d. If it is not within the specification, redo the adjustment and confirmation in steps 10, 11 and 12. This confirmation should be done at each tape selector position under each of the following conditions. Dolby B NR on and Dolby C NR on.
knob so that (2) voltage is E mode.	REC-PAUSE	PEAK LEVEL METER	VR401 VR402	Adjust to the point where the 0dB of the PEAK LEVEL METER lights.
LEVEL knob TP8 (TD202) E mode.	REC-PAUSE	OUTPUT jack		Confirm that attenuation of 15kHz and 19kHz is within the specification when MPX FILTER on.
knob so that mode.	REC-PAUSE	TP201 TP202		Confirm that attenuation of 20kHz is maximum. Dolby C NR is on.

TIMING CHART

IC801 : TC9312N-038

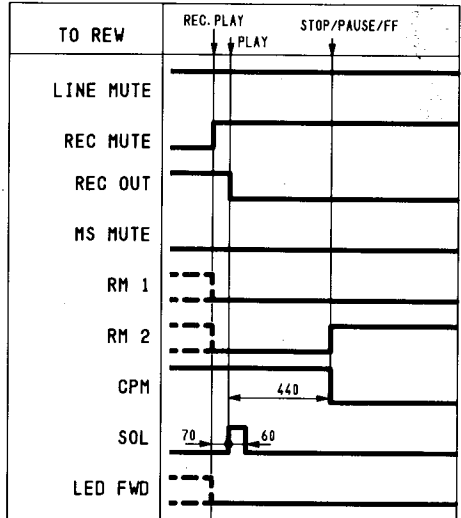
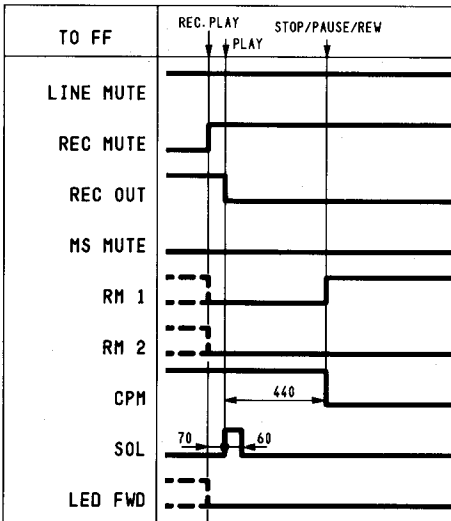
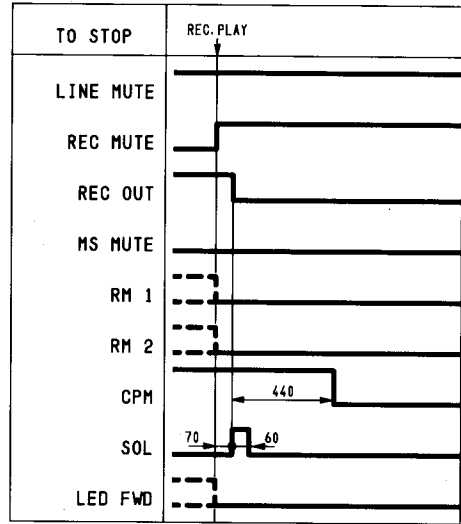
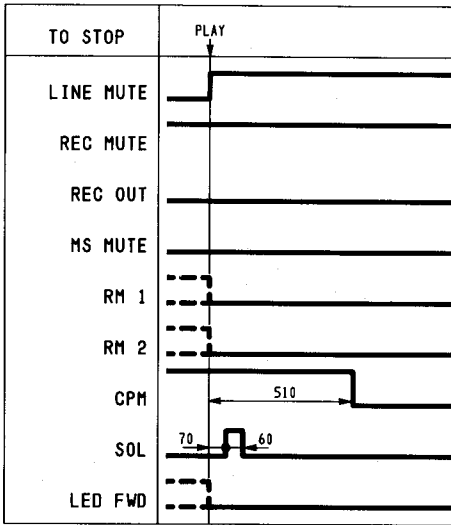
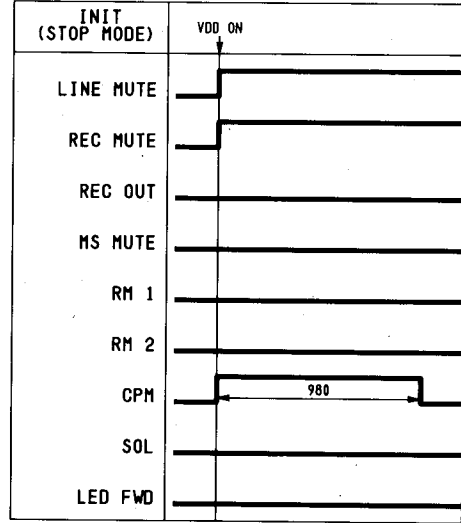
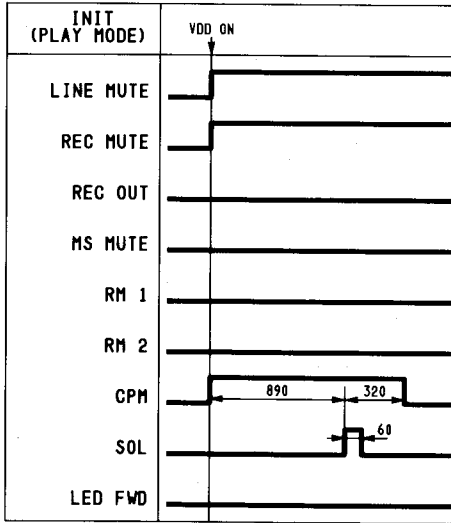

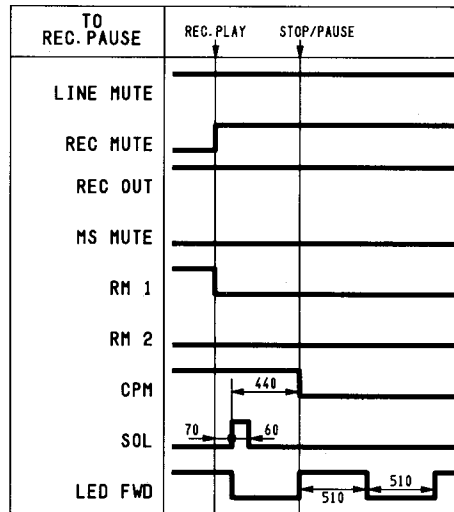
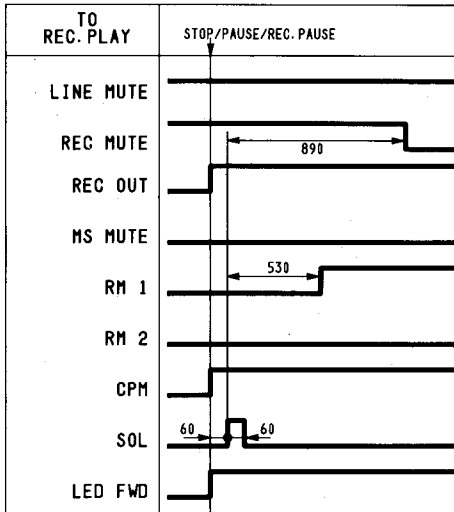
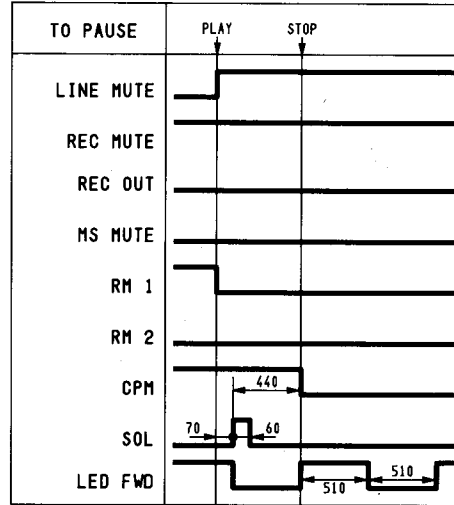
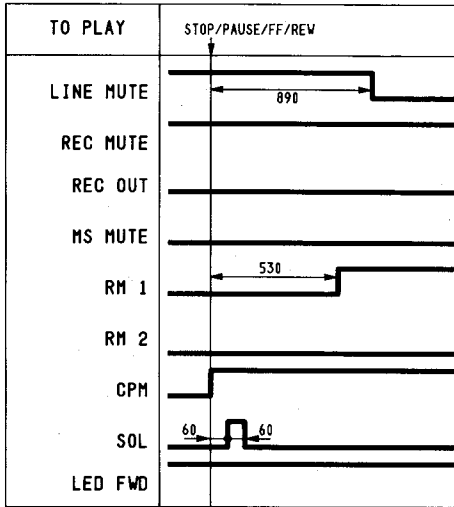

IC BLOCK DIAGRAM

IC201 : M5219P
Dual Operational Amplifier

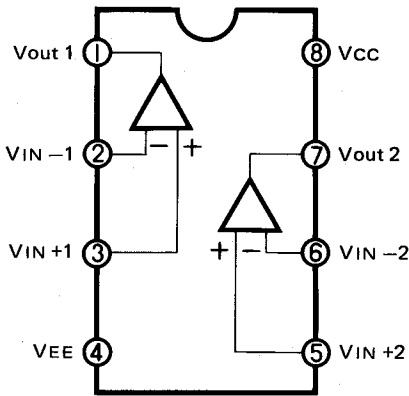

IC301 : M4066BP (TD102 only)
Quad Bilateral Switch

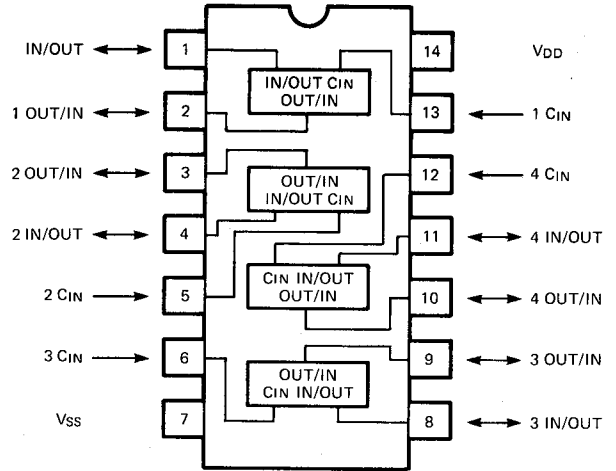

IC401, 402 : IR2E19
7-Dot LED Driver

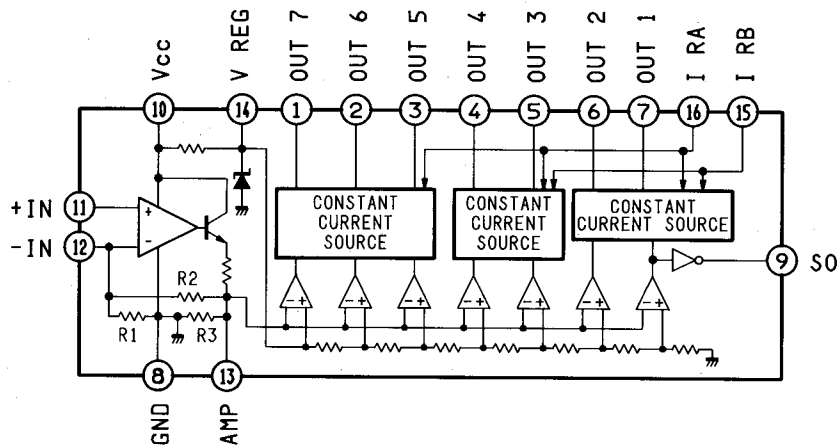

IC501 : HA12088NT (for TD202)
Dolby B-C NR

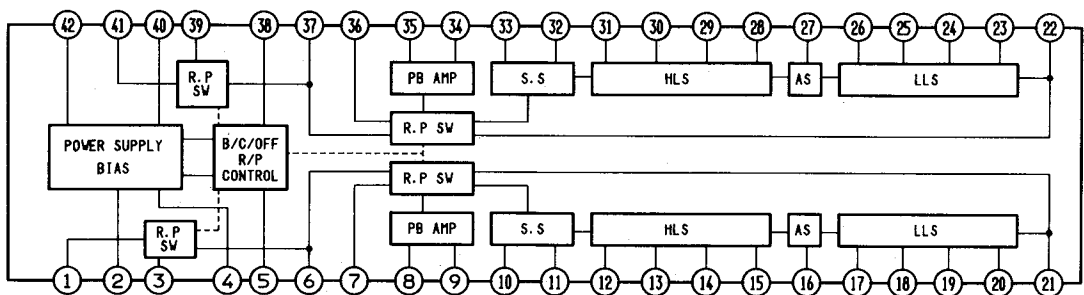

IC501, 502 : TA7629P (for TD102)
Dolby NR

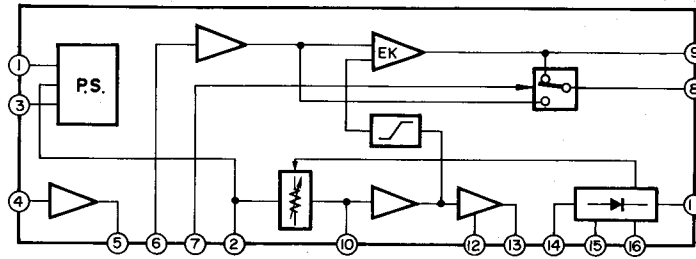

IC801 : TC9312N-038
Logic Controller

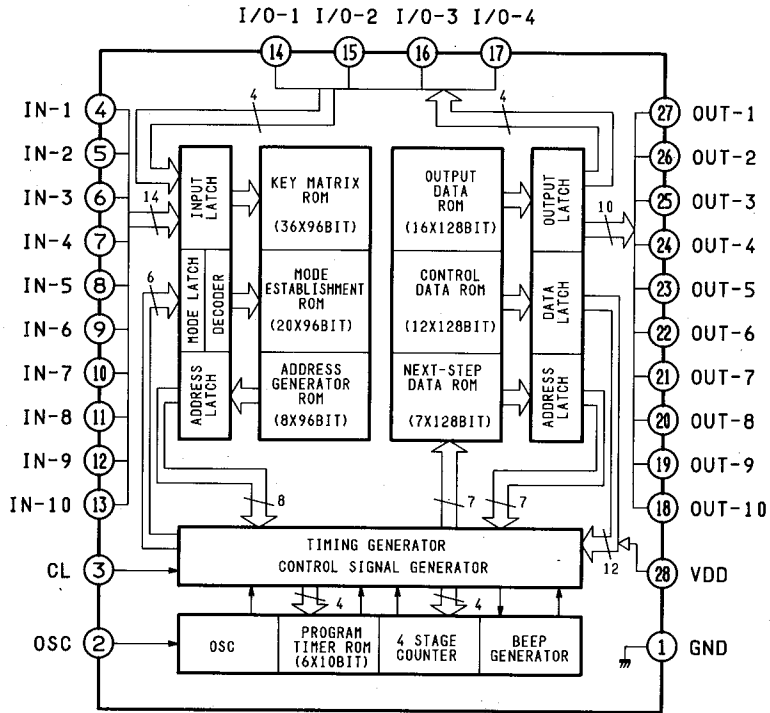

IC802 : TA7780BN
Motor Driver

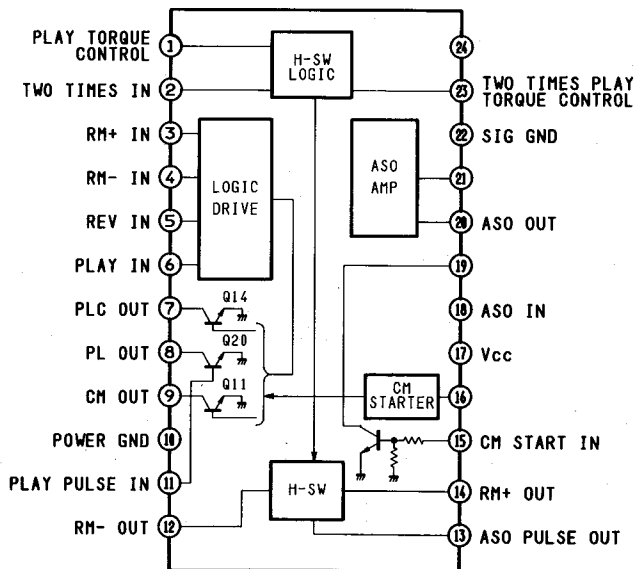

A

B

C

D

E

CASSETTE TAPE RECORDER MECHANISM EXPLODED VIEW

1

2

3

4

5

6

7

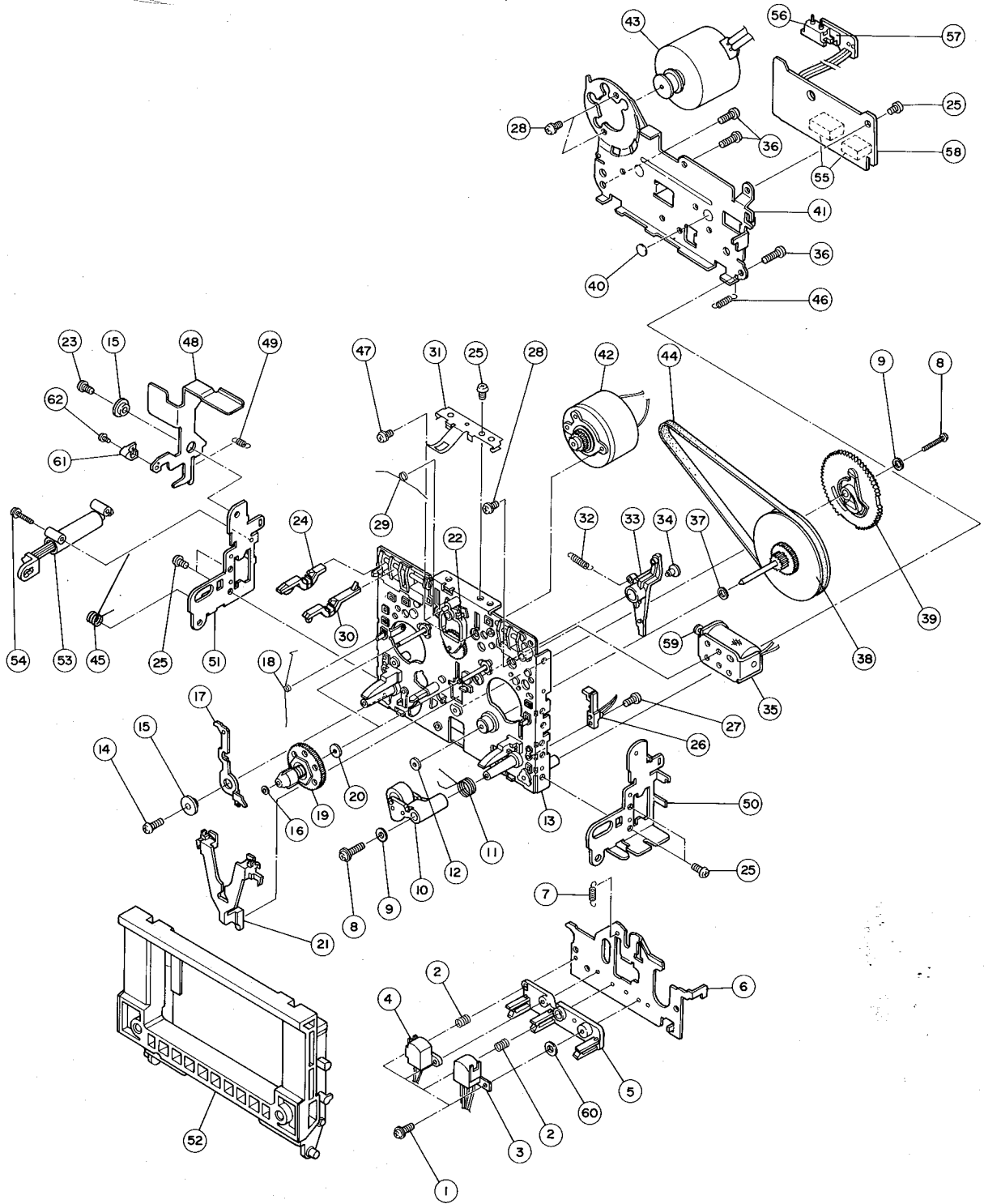

GENERAL UNIT PARTS LIST

Ref. No.	Part No.	Description	Ref. No.	Part No.	Description
101	A443-TD202A	Front Panel Ass'y (for TD202) U G	147	1662-25401VN	Push Button, Power, Eject U G
101	A443-TD102A	Front Panel Ass'y (for TD102) U G	147	1662-25402	Push Button, Power, Eject BK GB
101	A443-TD202B	Front Panel Ass'y (for TD202) BK GB	150	1660-00801	Push Button, REW, F. FWD, Rec./Pause, Rec. Mute U G
101	A443-TD102B	Front Panel Ass'y (for TD102) BK GB	150	1660-00802	Push Button, REW, F. FWD, Rec./Pause, Rec. Mute BK GB
102	A513-TD202A	Plate Ass'y			
103	A514-TD202A	Dressing Plate Ass'y			
104	A642-TD202A	Knob Ass'y, Input Level U G	151	1660-00901	Push Button, Play, Stop U G
104	A642-TD202B	Knob Ass'y, Input Level BK GB	151	1660-00902	Push Button, Play, Stop BK GB
105	A662-TD202A	Push Button Ass'y, Bias/ Equalization, Dolby NR, NR Type (TD202 only), MPX Filter U G	159	2114-01224	Bushing
			160	2310-7025	Special Screw U G
			160	2310-7026	Special Screw BK GB
			161	2132-01405	Spacer
105	A662-TD202C	Push Button Ass'y, Bias/ Equalization, Dolby NR, NR Type (TD202 only), MPX Filter BK GB	162	2132-7049	Spacer (TD202 only)
			164	2211-7280	Chassis
			166	2219-8095	Brecket
			167	2219-8096	Brecket
106	A662-TD202B	Push Button Ass'y, Counter Reset U G	168	2219-8097	Brecket
106	A662-TD202D	Push Button Ass'y, Counter Reset BK GB	169	2219-8098	Brecket
			170	2219-8099	Brecket
			171	2219-8100	Brecket
107	3112-13701	Cassette Tape Recorder Mechanism Ass'y	175	2222-7186	Heat Sink
			179	2240-364	Holder
124	1319-0139	Foot	180	2240-7120	Holder
126	1414-06701	Cabinet Top	182	2240-7264	Holder
128	1423-02601	Cabinet Bottom	185	2240-7110	Holder
129	1424-18401	Cabinet Back (for TD202) U BK	193	2601-7160	Shaft
129	1424-18403	Cabinet Back (for TD102) U BK	194	2601-7161	Shaft
129	1424-18402	Cabinet Back (for TD202) G GB	196	2642-01440	Belt
129	1424-18404	Cabinet Back (for TD102) G GB	198	2651-2101721	Spring
			205	2327-300529	Screw (3×5 mm)
			206	2327-300829	Screw (3×8 mm)
			208	2343-300627	Screw (3×6 mm)
			210	2347-300846	Screw (3×8 mm)
131	1442-12101	Panel, Input Level U G	213	2347-300626	Screw (3×6 mm)
131	1442-12102	Panel, Input Level BK GB	216	2347-300826	Screw (3×8 mm)
135	1514-17002	Dressing Plate U G	217	2347-400646	Screw (4×6 mm)
135	1514-17004	Dressing Plate BK GB		1111-J30245	Owner Guide U BK
139	1531-08501	Door Cover		1111-J30246	Owner Guide G GB
146	1632-13902VN	Rotary Knob, Bias Fine Trim (TD202 only) U G		1221-717184	Packing Box
146	1632-13901	Rotary Knob, Bias Fine Trim (TD202 only) BK GB		1222-7289	Packing Cushion

NOTES

Parts with the following marks are used only in the models intended for particular markets:

- U : U.S.A. model
- BK : U.S.A. model Black Version
- G : General model
- GB : General model Black Version

CASSETTE TAPE RECORDER MECHANISM PARTS LIST

<u>Ref. No.</u>	<u>Part No.</u>	<u>Description</u>	<u>Ref. No.</u>	<u>Part No.</u>	<u>Description</u>
1	FG137-18	Screw	33	F148S025	Play Arm Ass'y
2	FK21U-11	Spring	34	FC728-12	Cap
3	FUI6B-11	REC/PB Head	35	F265-240	Solenoid
4	FUI92-11	Erase Head	36	UG12H-14	Screw (2.6×8mm)
5	FD33C-11	Head Spacer	37	FJ111-30	Non-metal Washer
6	FC38N-46	Head Base	38	FRI8M-15	Flywheel Ass'y
7	FK22L-11	Head Base Spring	38	FRI9S-12	Flywheel Ass'y
8	UC12H-20	Screw (2×13mm)	39	FD34K-16	Cum Gear
9	MJ112-22	Washer	40	UJ11S-11	Spacer
10	F014-095	Pinch Roller	41	FC38P-35	Flywheel Bracket
11	FK22B-11	Pinch Roller Spring	42	F064S235	Reel Motor
12	FJ141-11	Oil Seal	43	F064-157	Capstan Motor
13	F112-083	Chassis	44	FF15R-11	Belt
14	UG12H-24	Screw (3×10mm)	45	FK21G-11	Door Spring
15	FM296-11	Spacer	46	FK22K-12	Ground Spring
16	FJ111-17	Non-metal Washer	47	FG114-14	Screw
17	FC39S-14	Eject Prevention Arm	48	FC45V-11	Eject Arm
18	FK22P-15	Eject Prevention Spring	49	FK23R-11	Eject Arm Spring
19	F105-027	Reel Ass'y	50	FC33K-14	Dumper Bracket (R)
20	UJ12V-11	Non-metal Washer	51	FC33L-14	Dumper Bracket (L)
21	FD35T-11	Hold Lever	52	FD35C-12	Door Frame Ass'y
22	F017-044	Idler Ass'y	53	FP472-11	Dumper Ass'y
23	KG194-12	Screw	54	UG12R-11	Screw
24	FD32C-32	Switch Arm, Pack	55	F067-073	Connector
25	KG194-46	Screw (3×4mm)	56	UE14U-16	Push Switch
26	UE14T-11	Leaf Switch	57	FD37E-12	Switch Spacer
27	UG12H-23	Screw (2×7mm)	58	FP15W-24	Relay P. C. Board
28	UG11S-14	Screw	59	PL358-12	Plunger
29	FK22E-11	Hold Spring	60	FJ111-19	Non-metal Washer
30	FD32B-32	Switch Arm, Rec.	61	FD37N-11	Fook
31	FC40N-32	Spring, Cassette	62	KG194-34	Screw
32	FK22G-13	Play Arm Spring			

ELECTRICAL PARTS LIST

Ref. No.	Part No.	Description	Ref. No.	Part No.	Description
CHASSIS MISCELLANEOUS					
△	PI	4161-71151			Power Cord U BK
△	PI	4161-7256			Power Cord G GB
	FU1	5732-102052			Fuse, 1A, 250V G GB
	VR255	5113-2028221			Control, 2kΩB, Bias Fine Trim (TD202 only)
		4161-71184			Connection Cord (Accessory)
PCB-1 MAIN P. C. BOARD					
RESISTORS					
△	R51	5102-1004715			10Ω, 1/4W, FR
△	R52	5102-1004715			10Ω, 1/4W, FR
	R105	5174-223381			22kΩ, 1/4W, MR
	R106	5174-223381			22kΩ, 1/4W, MR
	R107	5174-331381			330Ω, 1/4W, MR
	R108	5174-331381			330Ω, 1/4W, MR
△	R137	5102-4R74715			4.7Ω, 1/4W, FR
△	R252	5102-4R74715			4.7Ω, 1/4W, FR (for TD202)
△	R252	5102-1004715			10Ω, 1/4W, FR (for TD102)
	R513	5174-332381			3.3kΩ, 1/4W, MR (for TD102)
	R514	5174-332381			3.3kΩ, 1/4W, MR (for TD102)
△	R521	5102-4704715			47Ω, 1/4W, FR (for TD102)
△	R530	5102-1004715			10Ω, 1/4W, FR (TD202 only)
△	R821	5102-4704715			47Ω, 1/4W, FR
△	R823	5102-2205711			22Ω, 1W, FR
CONTROLS					
	VR101	5101-20301927			20kΩB
	VR102	5101-20301927			20kΩB
	VR103	5101-20201927			2kΩ
	VR104	5101-20201927			2kΩ
	VR201	5101-20271920			2kΩB
	VR202	5101-20271920			2kΩB
	VR251	5101-10371920			10kΩB
	VR252	5101-50271920			5kΩB
	VR253	5101-10401927			100kΩB
	VR254	5101-10401927			100kΩB
CAPACITORS					
	C3	5345-228D041			2200μF/25V, EC
	C4	5345-108C041			1000μF/16V, EC
	C5	5345-477C041			470μF/16V, EC
	C6	5345-107C041			100μF/16V, EC
	C8	5345-478C041			4700μF/16V, EC
	C51	5345-226D041			22μF/25V, EC
	C52	5345-226D041			22μF/25V, EC
	C101	5353-101534			100pF/500V, MC
	C102	5353-101534			100pF/500V, MC
	C103	5345-226C0951			22μF/16V, EC
	C104	5345-226C0951			22μF/16V, EC
	C105	5345-107B041			100μF/10V, EC
	C106	5345-107B041			100μF/10V, EC
	C107	5359-6825851			6800pF/100V, PC
	C108	5359-6825851			6800pF/100V, PC
	C109	5359-6825851			6800pF/100V, PC
	C110	5359-6825851			6800pF/100V, PC
	C111	5345-106C0951			10μF/16V, EC
	C112	5345-106C0951			10μF/16V, EC
	C113	5359-1225851			1200pF/100V, PC
	C114	5359-1225851			1200pF/100V, PC
	C115	5345-477C041			470μF/16V, EC
	C116	5345-336C041			33μF/16V, EC
	C201	5359-6815851			680pF/100V, PC
	C202	5359-6815851			680pF/100V, PC
	C209	5345-105F0952			1μF/50V, EC
	C210	5345-105F0952			1μF/50V, EC
	C211	5345-226C041			22μF/16V, EC
	C212	5345-226C041			22μF/16V, EC
	C213	5345-226C0952			22μF/16V, EC
	C214	5345-226C0952			22μF/16V, EC
	C219	5345-225F0952			2.2μF/50V, EC
	C220	5345-225F0952			2.2μF/50V, EC
	C223	5345-227C041			220μF/16V, EC
	C227	5359-3315851			330pF/100V, PC
	C228	5359-3315851			330pF/100V, PC
	C251	5345-107C041			100μF/16V, EC
	C253	5353-101534			100pF/500V, MC
	C254	5353-101534			100pF/500V, MC
	C301	5345-105F0951			1μF/50V, EC (TD102 only)
	C302	5345-105F0951			1μF/50V, EC (TD102 only)
	C305	5345-476C041			47μF/16V, EC (TD102 only)
	C501	5345-105F0951			1μF/50V, EC (for TD102)
	C502	5345-105F0951			1μF/50V, EC (for TD102)
	C503	5345-106C0952			10μF/16V, EC (for TD102)
	C504	5345-106C0952			10μF/16V, EC (for TD102)
	C505	5345-106C0952			10μF/16V, EC (for TD102)
	C506	5345-106C0952			10μF/16V, EC (for TD102)
	C507	5345-106C0952			10μF/16V, EC (for TD202)
	C508	5345-106C0952			10μF/16V, EC (for TD202)
	C509	5345-477C041			470μF/16V, EC (for TD202)
	C511	5345-106C0952			10μF/16V, EC (for TD202)
	C511	5359-3325851			3300pF/100V, PC (for TD102)
	C512	5345-106C0952			10μF/16V, EC (for TD202)
	C512	5359-3325851			3300pF/100V, PC (for TD102)
	C513	5345-106C0951			10μF/16V, EC (for TD202)
	C514	5345-106C0951			10μF/16V, EC (for TD202)
	C515	5345-477C041			470μF/16V, EC (for TD202)
	C516	5345-226C041			22μF/16V, EC (for TD202)
	C517	5345-106C041			10μF/16V, EC (for TD202)
	C518	5345-106C041			10μF/16V, EC (for TD202)
	C519	5345-226C0951			22μF/16V, EC (for TD202)
	C520	5345-226C0951			22μF/16V, EC (for TD202)
	C521	5359-103741			0.01pF/100V, PC (for TD202)
	C521	5345-106C0952			10μF/16V, EC (for TD102)
	C522	5359-103741			0.01pF/100V, PC (for TD202)
	C522	5345-106C0952			10μF/16V, EC (for TD102)
	C523	5345-105F0952			1μF/50V, EC (for TD202)
	C523	5345-104F0952			0.1μF/50V, EC (for TD102)
	C524	5345-105F0952			1μF/50V, EC (for TD202)
	C524	5345-104F0952			0.1μF/50V, EC (for TD102)
	C525	5345-334F0952			0.33μF/50V, EC (for TD102)
	C526	5345-334F0952			0.33μF/50V, EC (for TD102)
	C527	5345-684F0952			0.68μF/50V, EC (for TD202)
	C527	5345-106C0951			10μF/16V, EC (for TD102)
	C528	5345-684F0952			0.68μF/50V, EC (for TD202)
	C528	5345-106C0951			10μF/16V, EC (for TD102)
	C529	5345-225F0952			2.2μF/50V, EC (for TD202)
	C529	5345-106C0951			10μF/16V, EC (for TD102)
	C530	5345-225F0952			2.2μF/50V, EC (for TD202)
	C530	5345-106C0951			10μF/16V, EC (for TD102)
	C531	5345-477C041			470μF/16V, EC (for TD102)
	C532	5345-477C041			470μF/16V, EC (for TD102)
	C533	5359-103741			0.01pF/100V, PC (for TD202)
	C533	5345-227C041			220μF/16V, EC (for TD102)
	C534	5359-103741			0.01pF/100V, PC (for TD202)
	C534	5345-227C041			220μF/16V, EC (for TD102)
	C535	5345-226C041			22μF/16V, EC (for TD102)
	C537	5345-684F0952			0.68μF/50V, EC (for TD202)
	C537	5345-335F041			3.3μF/50V, EC (for TD102)
	C538	5345-684F0952			0.68μF/50V, EC (TD202 only)
	C539	5345-225F0952			2.2μF/50V, EC (TD202 only)
	C540	5345-225F0952			2.2μF/50V, EC (TD202 only)
	C541	5345-106C0952			10μF/16V, EC (TD202 only)
	C542	5345-106C0952			10μF/16V, EC (TD202 only)
	C543	5345-106C0952			10μF/16V, EC (TD202 only)
	C544	5345-106C0952			10μF/16V, EC (TD202 only)
	C569	5345-335F041			3.3μF/50V, EC (TD202 only)
	C701	5345-475D041			4.7μF/25V, EC
	C803	5345-106C041			10μF/16V, EC
	C804	5345-475D041			4.7μF/25V, EC
	C805	5345-107B041			100μF/10V, EC

Ref. No.	Part No.	Description
LCN201	4163-0518032	CLW, 5 Pos.
LCN202	4163-0415032	CLW, 4 Pos.
CN1	4443-0201102	Connector, 2 Pos.
CN2	4443-0601102	Connector, 6 Pos.
CN101	4443-040185	Connector, 4 Pos.
CN102	4443-070185	Connector, 7 Pos.
CN103	4443-050185	Connector, 5 Pos.
CN104	4443-040185	Connector, 4 Pos.
CN105	4443-030185	Connector, 3 Pos. (TD202 only)
CN107	4443-080185	Connector, 8 Pos.
CN108	4443-030185	Connector, 3 Pos.
CN110	4443-030185	Connector, 3 Pos.

PCB-2 DISPLAY P. C. BOARD

CONTROLS		
VR351	5223-5037116	50k Ω , Input Level
VR352	5223-5037116	50k Ω , Input Level
VR401	5101-10301927	10k Ω
VR402	5101-10301927	10k Ω

CAPACITORS		
C401	5345-225F0961	2.2 μ F/50V, EC
C402	5345-225F0961	2.2 μ F/50V, EC
C403	5345-475D0961	4.7 μ F/25V, EC
C404	5345-475D0961	4.7 μ F/25V, EC
C405	5345-106C0961	10 μ F/16V, EC
C406	5345-106C0961	10 μ F/16V, EC
C407	5345-226C0961	22 μ F/16V, EC
C408	5345-226C0961	22 μ F/16V, EC

INTEGRATED CIRCUITS		
IC401	5652-IR2E19	IR2E19
IC402	5652-IR2E19	IR2E19

DIODES		
D403	5637-GL9EG9	L.E.D., GL9EG9, Green, Peak Level Meter
D404	5637-GL9EG9	L.E.D., GL9EG9, Green, Peak Level Meter
D405	5637-GL9EG9	L.E.D., GL9EG9, Green, Peak Level Meter
D406	5637-GL9EG9	L.E.D., GL9EG9, Green, Peak Level Meter
D407	5637-GL9EG9	L.E.D., GL9EG9, Green, Peak Level Meter
D408	5637-GL9EG9	L.E.D., GL9EG9, Green, Peak Level Meter
D409	5637-GL9EG9	L.E.D., GL9EG9, Green, Peak Level Meter
D410	5637-GL9EG9	L.E.D., GL9EG9, Green, Peak Level Meter
D411	5637-GL9PR9	L.E.D., GL9PR9, Red, Peak Level Meter
D412	5637-GL9PR9	L.E.D., GL9PR9, Red, Peak Level Meter
D413	5637-GL9PR9	L.E.D., GL9PR9, Red, Peak Level Meter
D414	5637-GL9PR9	L.E.D., GL9PR9, Red, Peak Level Meter
D415	5637-GL9PR9	L.E.D., GL9PR9, Red, Peak Level Meter
D416	5637-GL9PR9	L.E.D., GL9PR9, Red, Peak Level Meter
D417	5637-GL9EG9	L.E.D., GL9EG9, Green, Dolby NR B
D418	5637-GL9HY9	L.E.D., GL9HY9, Amber, Dolby NR C (TD202 only)

Ref. No.	Part No.	Description
D419	5637-GL9PR9	L.E.D., GL9PR9, Red, Rec.
D420	5637-GL9EG9	L.E.D., GL9EG9, Green, Play

PCB-3 POWER SUPPLY P. C. BOARD

RESISTORS		
Δ	R12	5135-335583 3.3M Ω , 1/4W, CAR G GB

CAPACITORS		
Δ	C1	5361-1030419 0.01 μ F /AC 125V, CC U BK
Δ	C1	5352-1030958 0.01 μ F /AC 250V, MPC G GB

MISCELLANEOUS		
Δ	T1	5584-701520 Power Transformer U BK
Δ	T1	5584-702520 Power Transformer G GB
Δ	S1	4431-A01056 Push Switch, Power
Δ	S2	4411-1047111 Rotary Switch, Voltage Selector G GB
	CN109	4443-030185 Connector, 3 Pos.
		4472-0131 Fuse Holder G GB

PCB-4 CONTROL SWITCHES P. C. BOARD

DIODES		
D705	5635-RD2R7EB2	ZD, RD2.7EB2
D801	5631-IS2473	IS2473
D802	5631-IS2473	IS2473
D803	5631-IS2473	IS2473
D804	5631-IS2473	IS2473
D805	5631-IS2473	IS2473
D806	5631-IS2473	IS2473

MISCELLANEOUS		
S801	4431-A010131	Push Switch, F. FWD
S802	4431-A010131	Push Switch, Stop
S803	4431-A010131	Push Switch, Rec./Pause
S804	4431-A010131	Push Switch, Play
S805	4431-A010131	Push Switch, REW
S806	4431-A010131	Push Switch, Rec. Mute

PCB-5 FUNCTION SWITCHES P. C. BOARD

S201	4431-06127159	Push Switch, LN (for TD202)
S201	4431-05107161	Push Switch, LN (for TD102)
S202	4431-06127159	Push Switch, CrO ₂ (for TD202)
S202	4431-05107161	Push Switch, CrO ₂ (for TD102)
S203	4431-06127159	Push Switch, Metal (for TD202)
S203	4431-05107161	Push Switch, Metal (for TD102)
S501	4431-06127159	Push Switch, MPX Filter (for TD202)
S501	4431-05107161	Push Switch, MPX Filter (for TD102)
S502	4431-06127159	Push Switch, Dolby NR Type (TD202 only)
S503	4431-06127159	Push Switch, Dolby NR (for TD202)
S503	4431-05107161	Push Switch, Dolby NR (for TD102)
CN106	4443-030185	Connector, 3 Pos.

Ref. No.	Part No.	Description
PCB-6 POWER IND. P. C. BOARD		
D421	5637-GL5HD10	L.E.D., GL5HD10, Red, Power

NOTES

Parts with the following marks are used only in the models intended for particular markets:

- U : U.S.A. model
- BK : U.S.A. model Black Version
- G : General model
- GB : General model Black Version

KEY TO ABBREVIATIONS

- FR : Fuse Resistor
- MR : Metal Resistor
- CR : Cement Resistor
- CAR : Carbon Resistor
- EC : Electrolytic Capacitor
- PC : Polypropylene Capacitor
- MC : Mica Capacitor
- CC : Ceramic Capacitor
- MPC: Metalized Polyester Capacitor
- SPC : Special Capacitor
- ZD : Zener Diode
- CLW: Connector with Lead Wire

 SAFETY RELATED COMPONENT. USE ONLY EXACT REPLACEMENT PART AS SPECIFIED.

PIN CONNECTION DIAGRAM OF TRANSISTORS, DIODES AND ICS

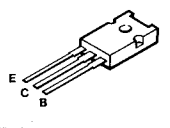
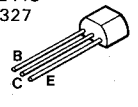
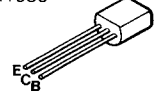
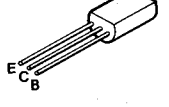
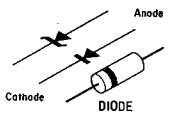
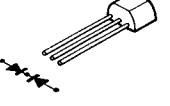
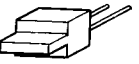
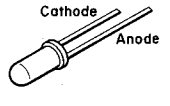
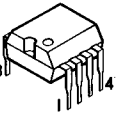
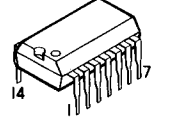
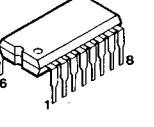
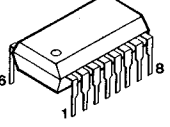
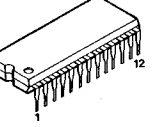
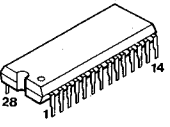
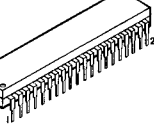
<p>2SA 1359 2SC3422</p> 	<p>2SC2603 2SA1115 2SC3378 RT1N241S RT1P241S 2SC3327</p> 
<p>2SC3246 2SC1775 2SC2320L 2SC2878 2SA1335</p> 	<p>2SA1286 2SC3246</p> 
<p>HZ12C2L RD8.2EB1 RD12EB2 RD6.2EB2 1S2473 S5566B HZ11B2L 1S2471 RD2.7EB2 RD2.7EB1 RD3.9EB2</p> 	
<p>MC921</p> 	<p>GL9EG9 GL9PR9 GL9HY9</p> 
<p>GL5HD10</p> 	<p>M5219P</p> 
<p>M4066BP</p> 	<p>TA7629P</p> 
<p>IR2E19</p> 	<p>TA7780BN</p> 
<p>TC9312N-038</p> 	<p>HA12088NT</p> 

WIRING DIAGRAM

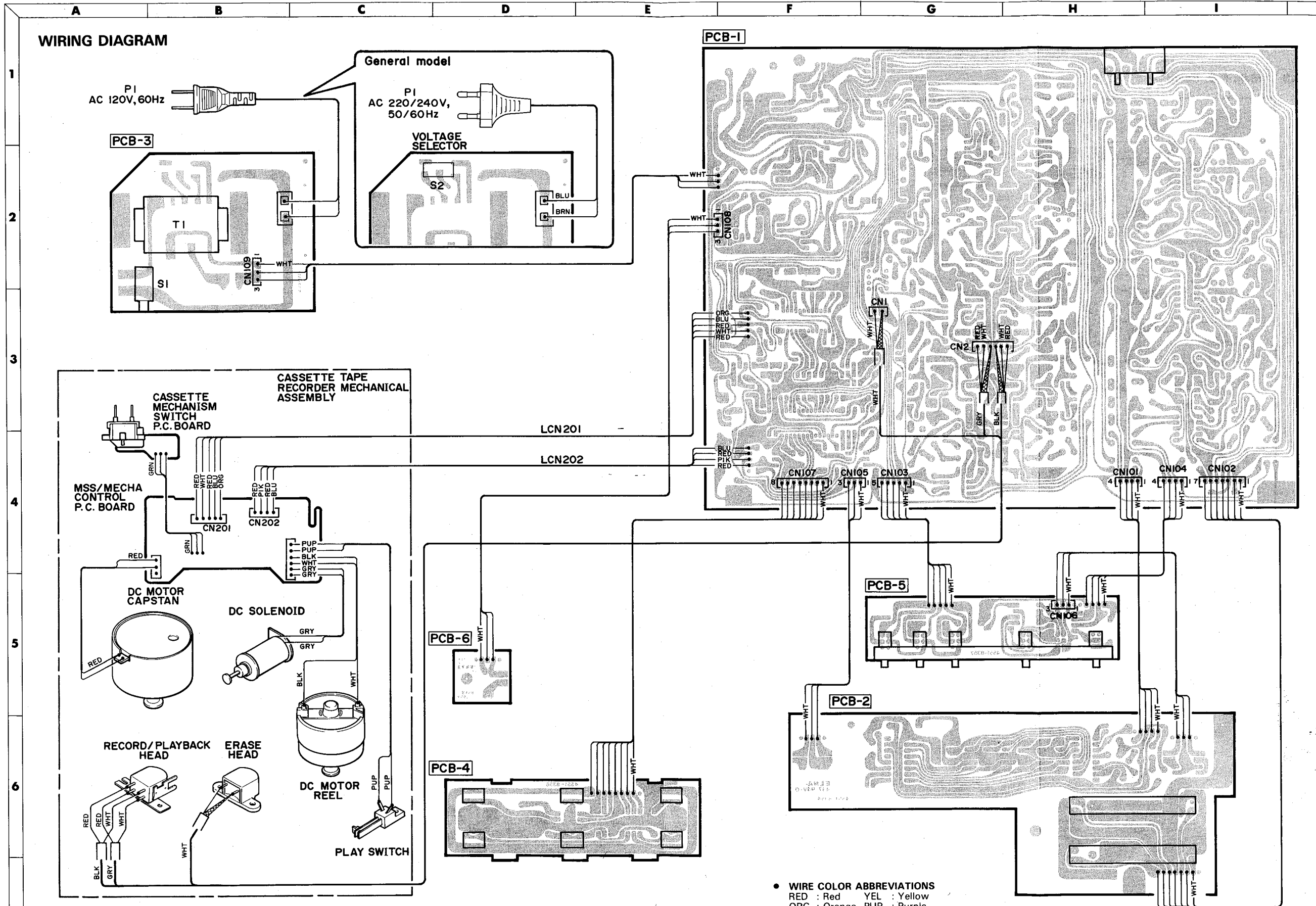

- WIRE COLOR ABBREVIATIONS
- RED : Red YEL : Yellow
- ORG : Orange PUP : Purple
- BLU : Blue PIK : Pink
- WHT : White GRY : Gray
- GRN : Green BRN : Brown
- BLK : Black

WIRING DIAGRAM

1
2
3
4
5
6
7

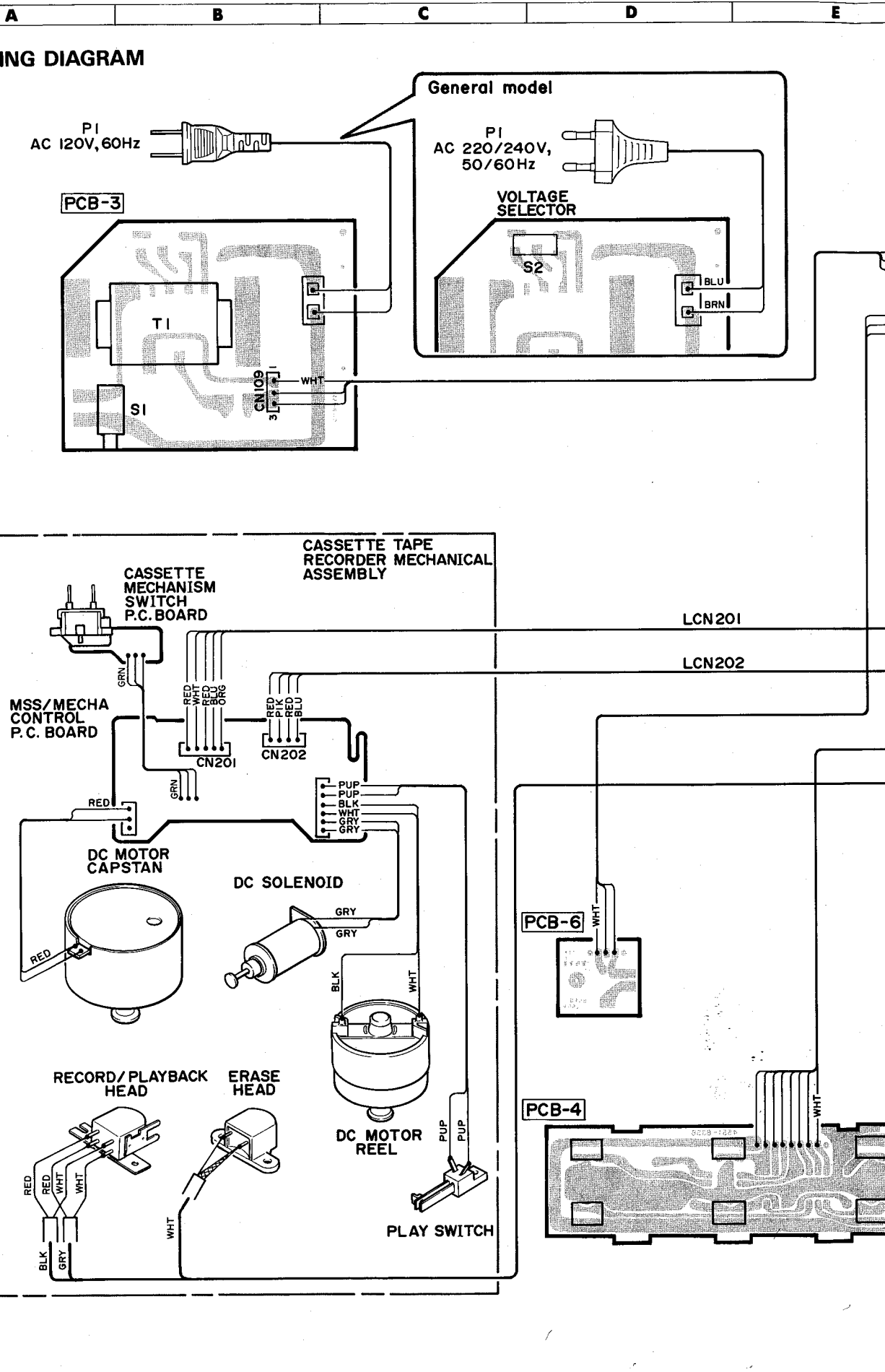

E F G H I J

PCB-1

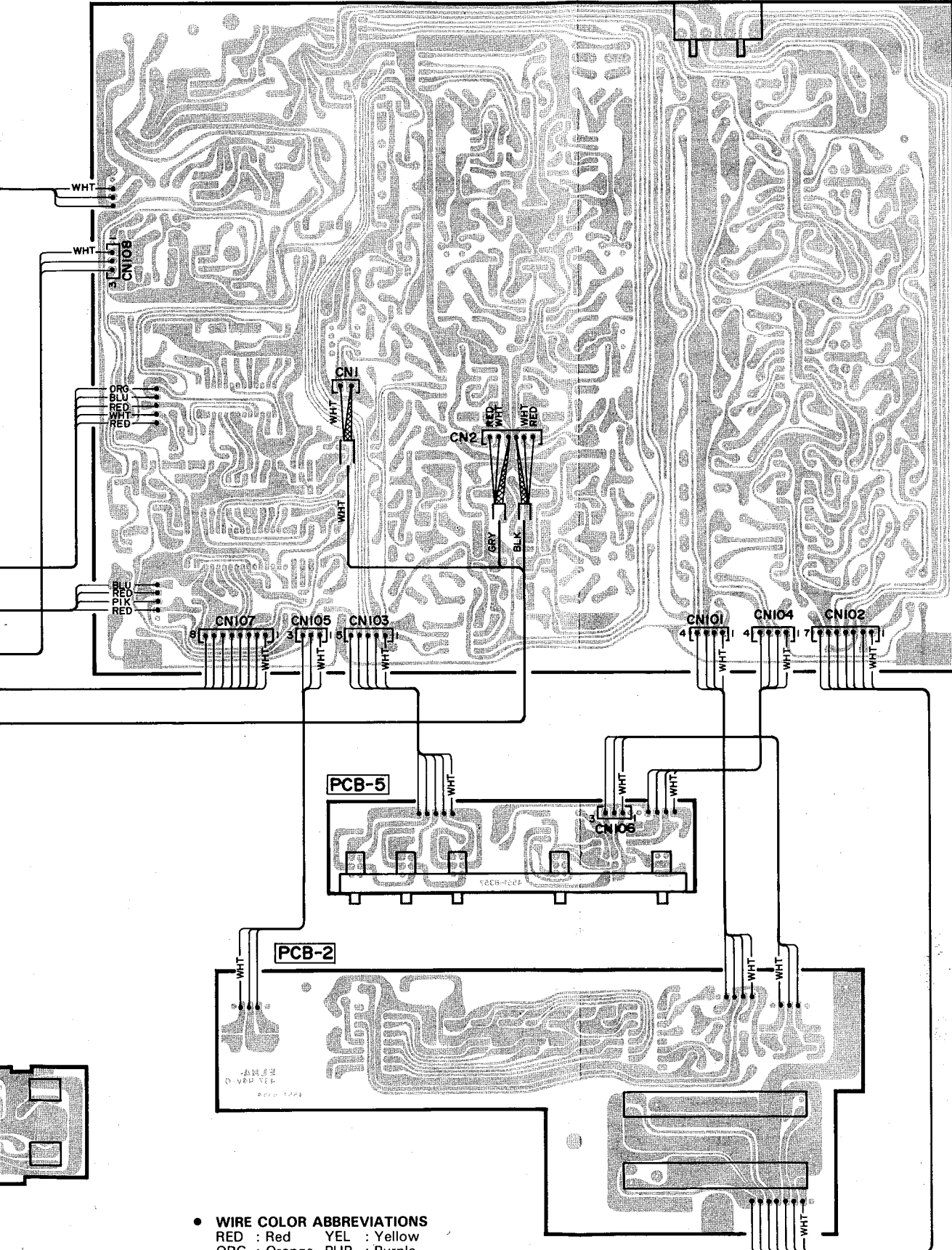

- **WIRE COLOR ABBREVIATIONS**
- RED : Red YEL : Yellow
- ORG : Orange PUP : Purple
- BLU : Blue PIK : Pink
- WHT : White GRY : Gray
- GRN : Green BRN : Brown
- BLK : Black

P. C. BOARDS (1)

PCB-1 Main P.C. Board

PLAYBACK FREQUENCY CHARACTER

PLAYBACK OUTPUT LEVEL ADJ.

PEAKING COIL & RECORD/PLAYBACK EQUALIZER FREQUENCY CHARACTER ADJ.

RECORD LEVEL ADJ.

BIAS LEVEL CHARACTER

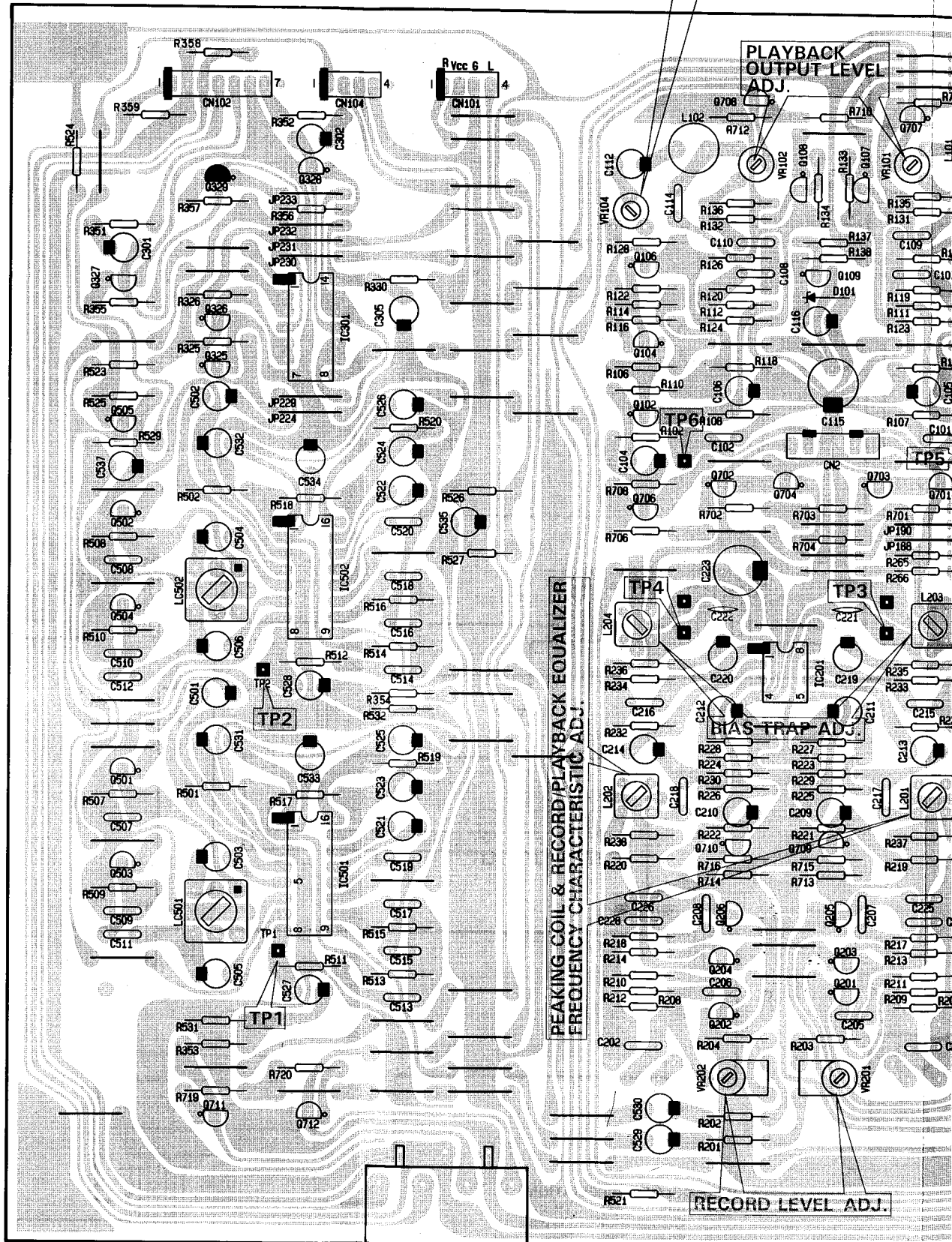

INPUT OUTPUT
 LEFT LEFT
 RIGHT RIGHT

CHARACTERISTIC ADJ.

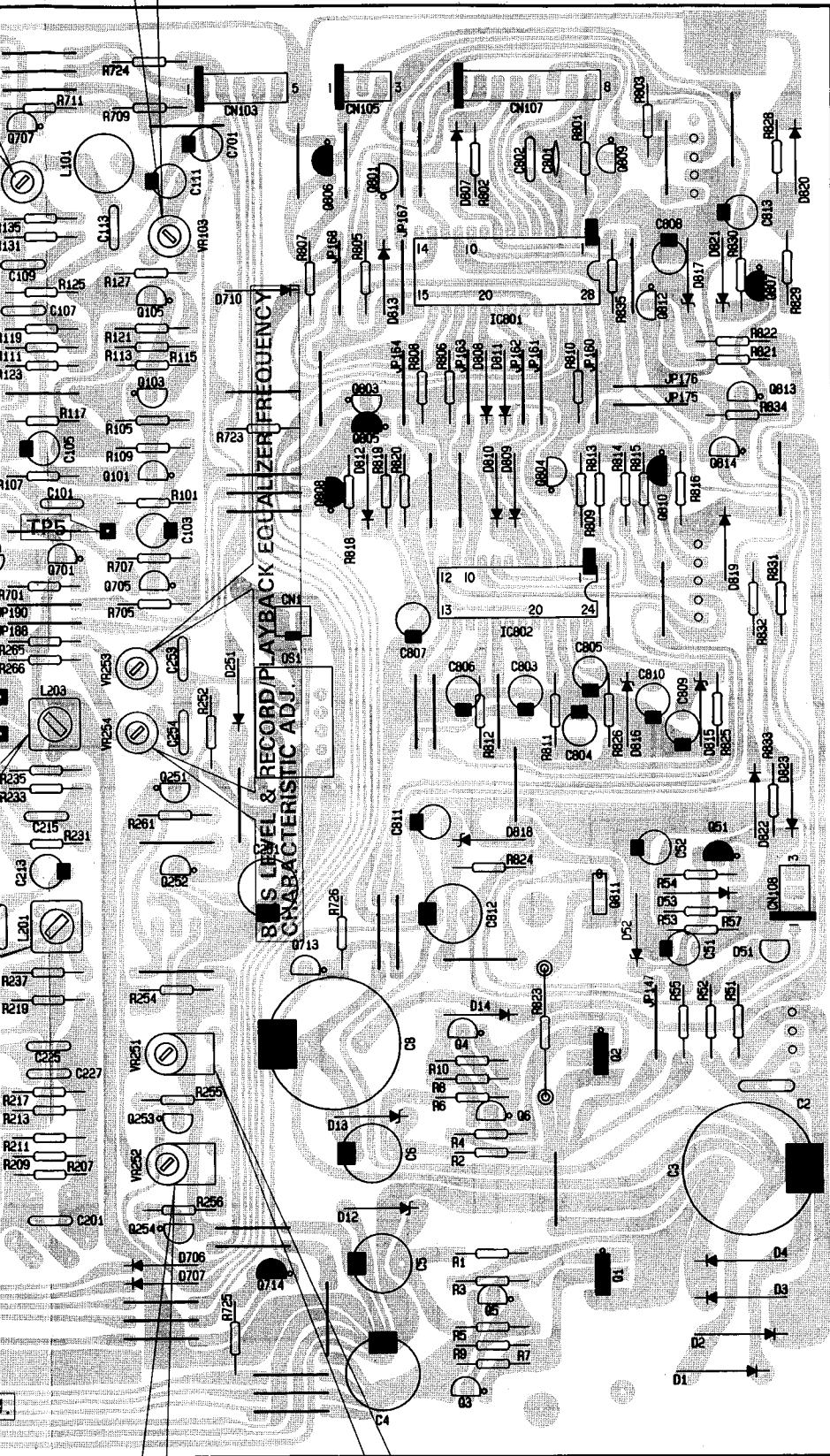

BASS LEVEL & RECORD/PLAYBACK EQUALIZER FREQUENCY CHARACTERISTIC ADJ.

P. C. BOARDS (2)

PCB-2 Display P.C. Board

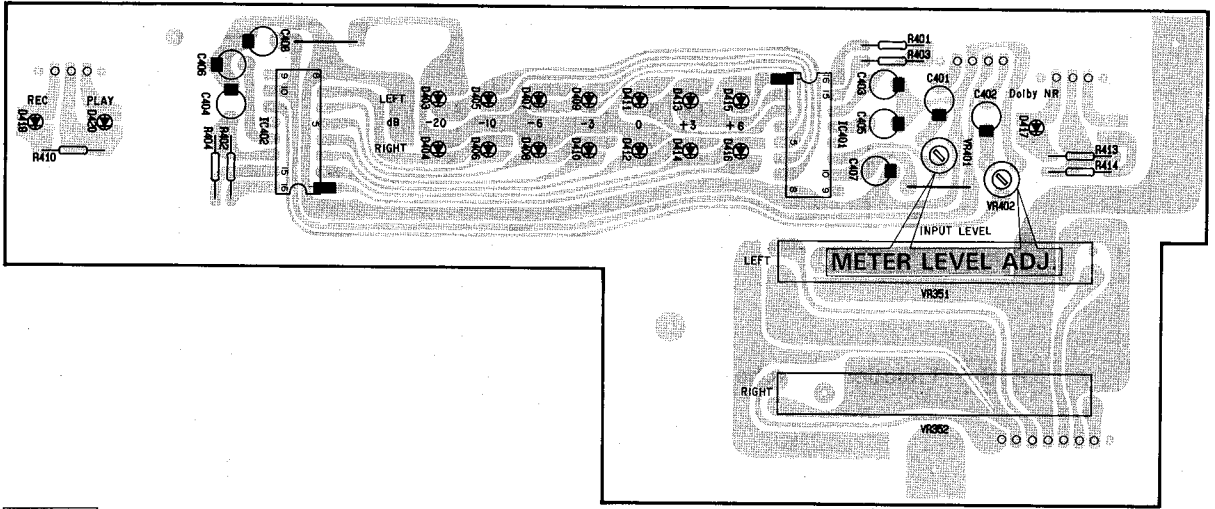

PCB-3 Power Supply P.C. Board

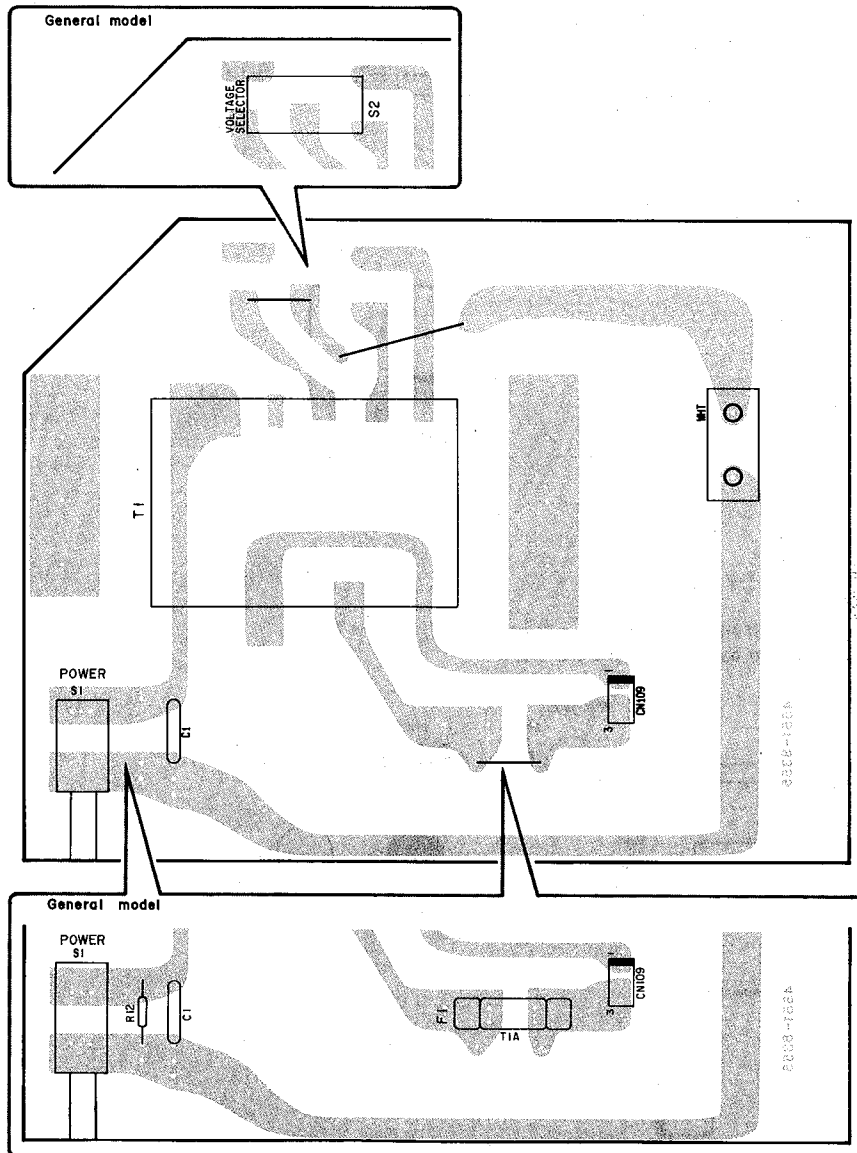

P. C. BOARDS (3)

PCB-4 Control Switches P.C. Board

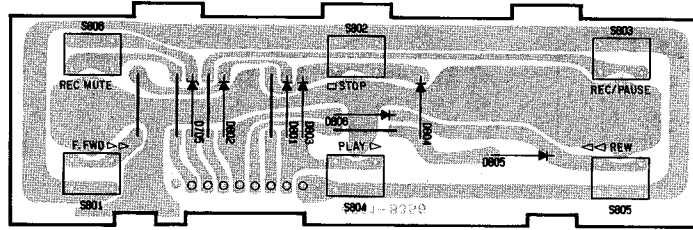

PCB-5 Function Switches P.C. Board

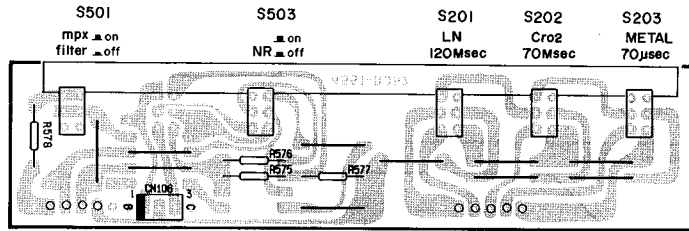

PCB-6 Power Ind. P.C. Board

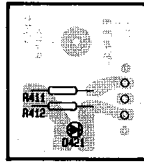

NOTE:

In the figures of the P. C. Boards, a mark is provided on the base side of the transistor.

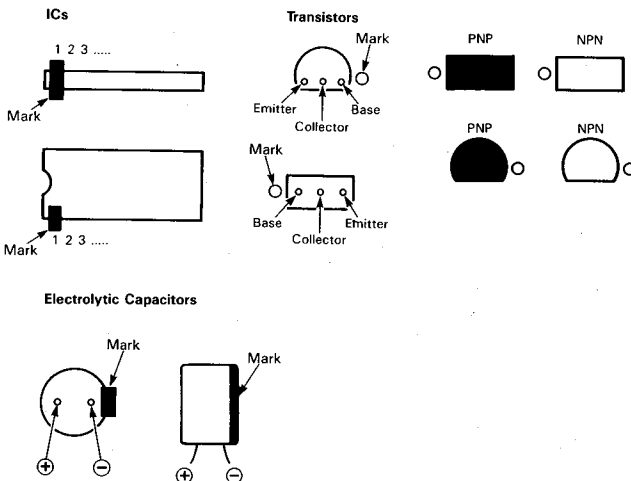

SCHEMATIC DIAGRAM (1)

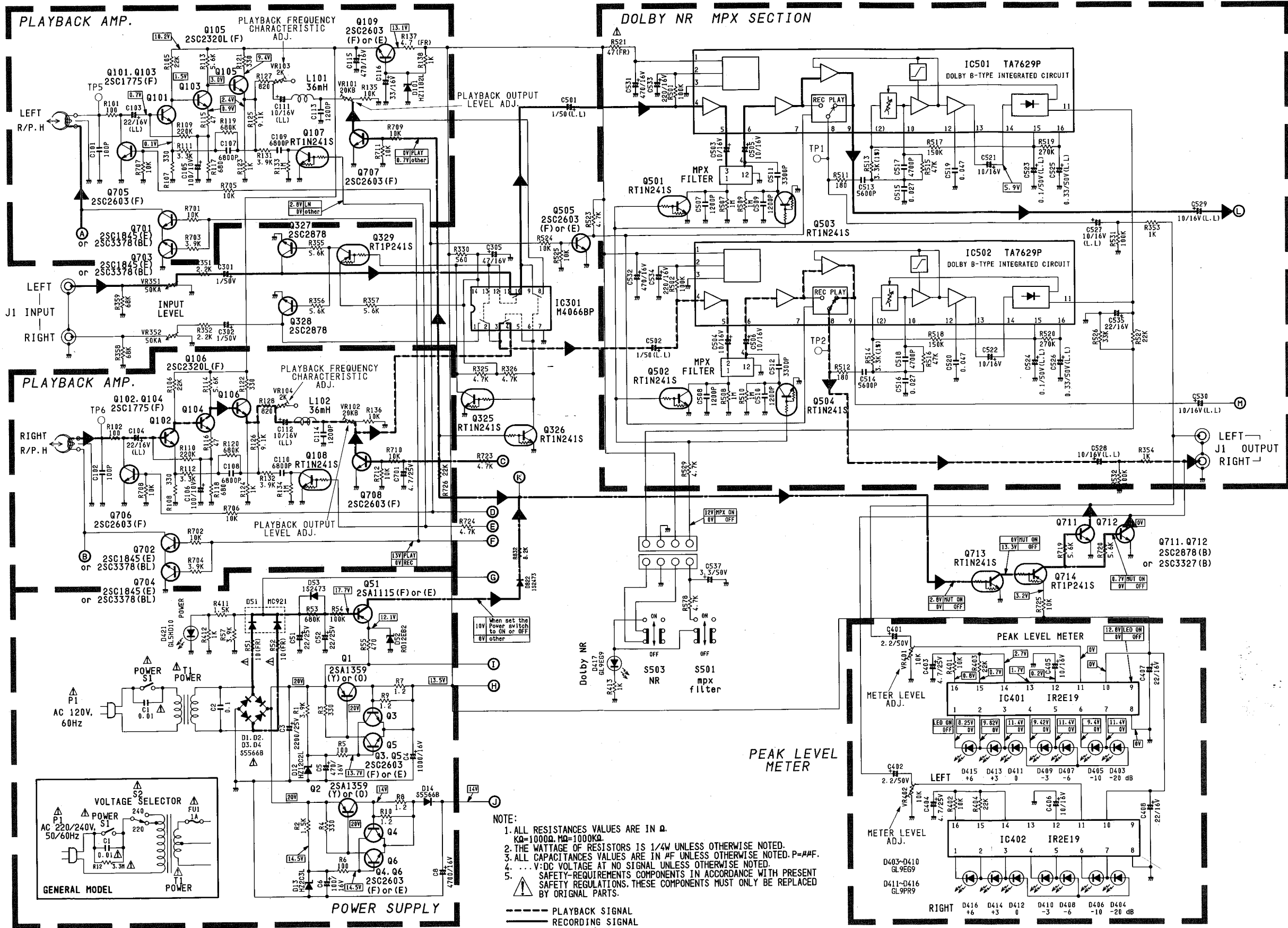

- NOTE:
1. ALL RESISTANCES VALUES ARE IN Ω .
K Ω =1000 Ω , M Ω =1000K Ω .
 2. THE WATTAGE OF RESISTORS IS 1/4W UNLESS OTHERWISE NOTED.
 3. ALL CAPACITANCE VALUES ARE IN μ F UNLESS OTHERWISE NOTED. P=PMF.
 4. ... V:DC VOLTAGE AT NO SIGNAL UNLESS OTHERWISE NOTED.
 5. SAFETY-REQUIREMENTS COMPONENTS IN ACCORDANCE WITH PRESENT SAFETY REGULATIONS.THESE COMPONENTS MUST ONLY BE REPLACED BY ORIGINAL PARTS.

--- PLAYBACK SIGNAL
 --- RECORDING SIGNAL
 --- MUTING SIGNAL

SCHEMATIC DIAGRAM (1)

1
2
3
4
5
6
7

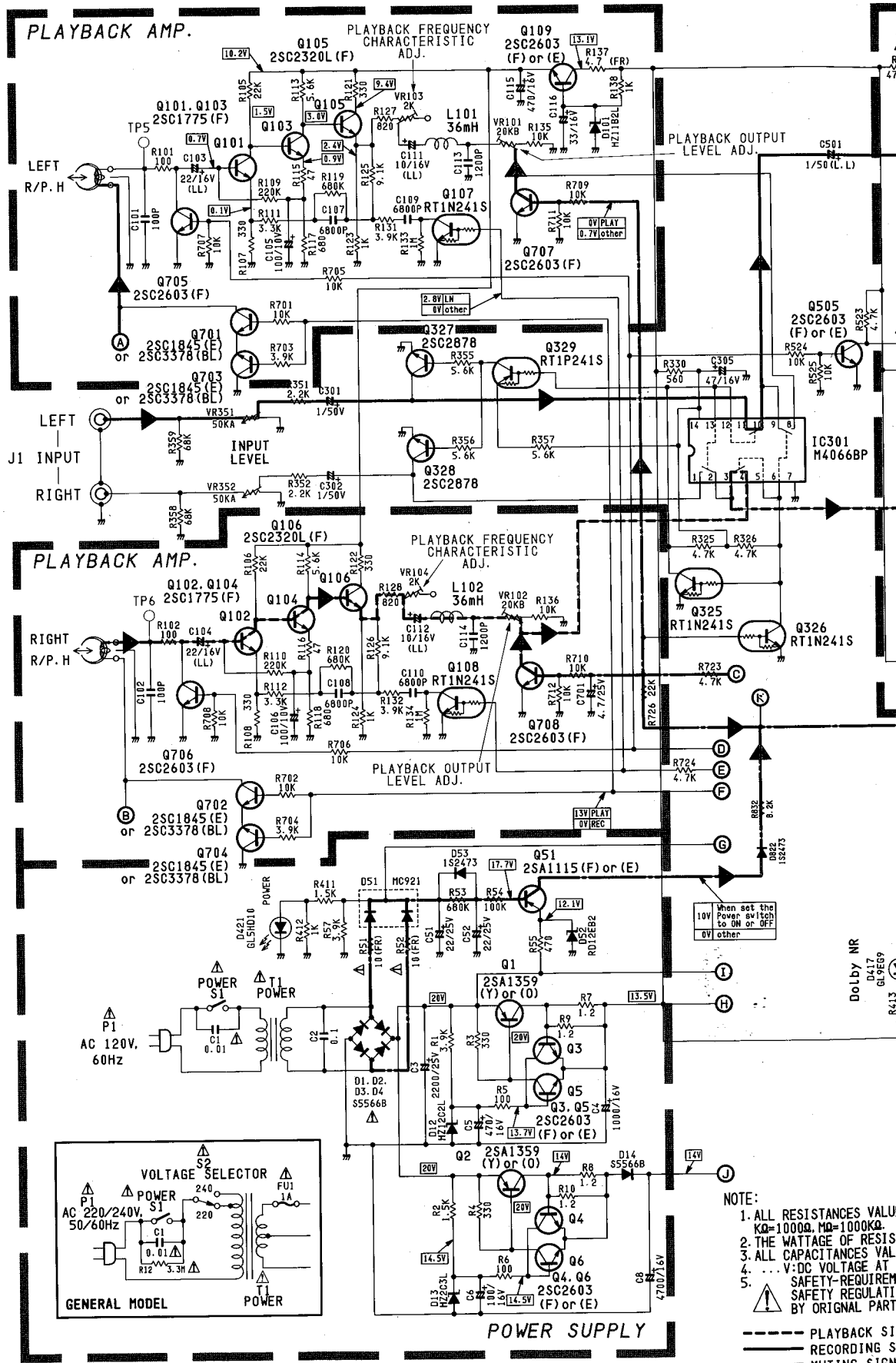

Dolby NR
D417
GL9EG9
8A13

E F G H I J

DOLBY NR MPX SECTION

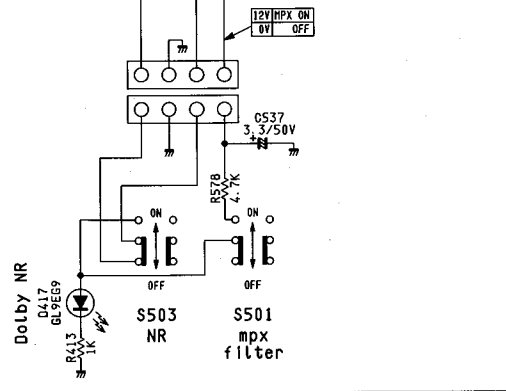
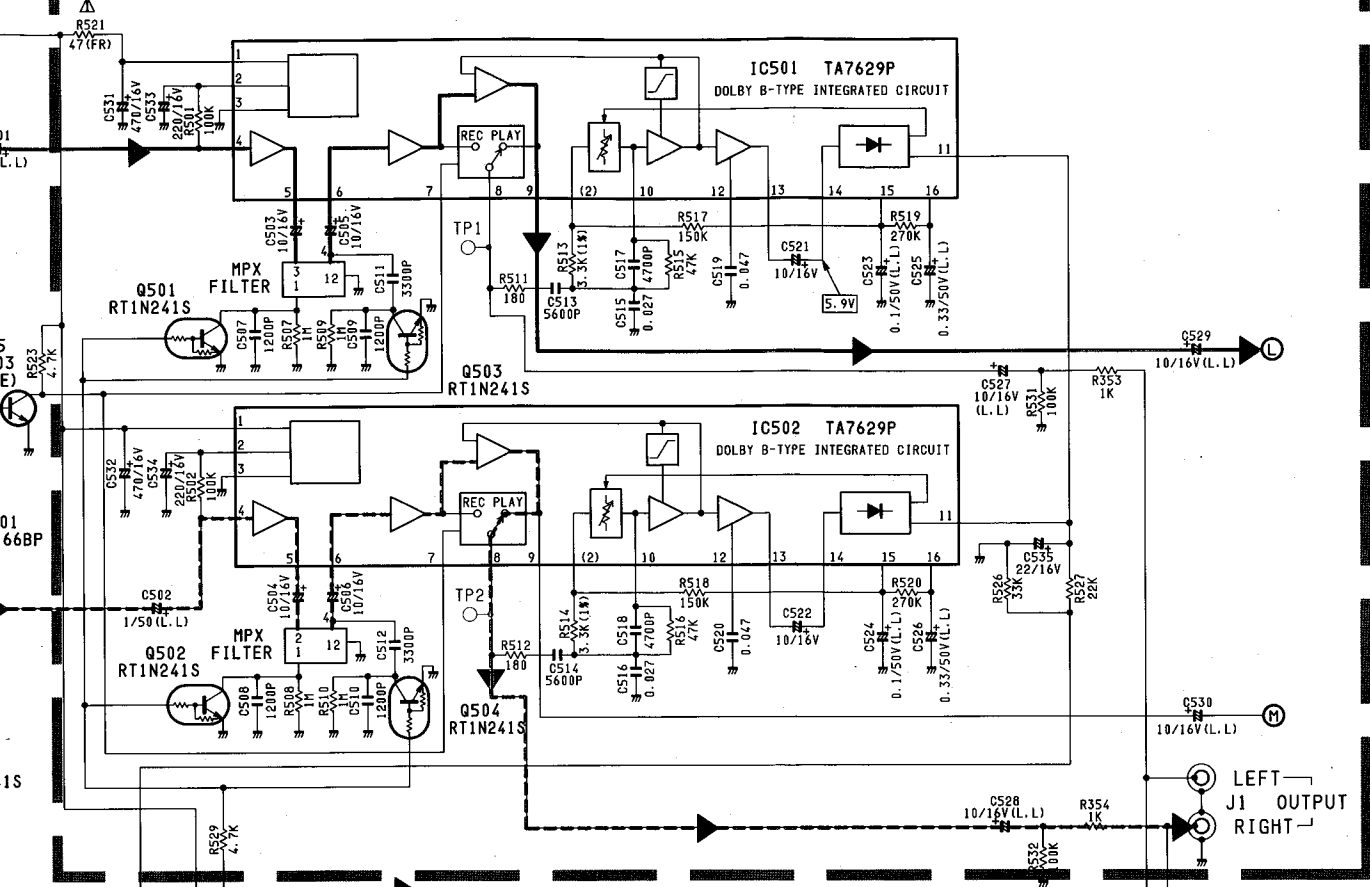

PEAK LEVEL METER

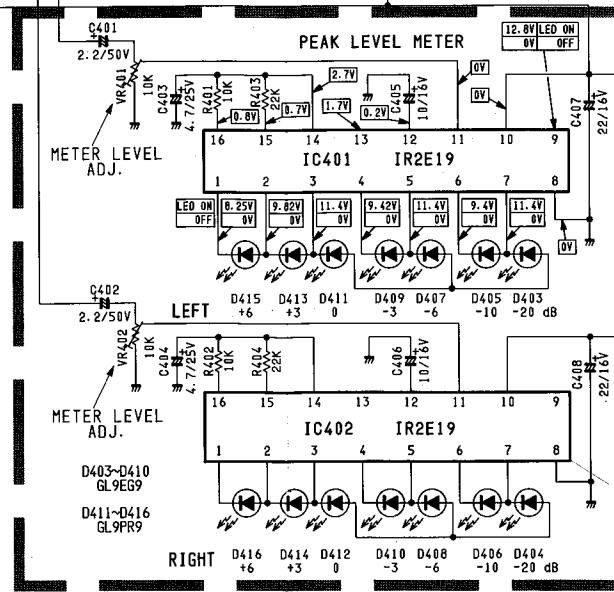

RESISTOR VALUES ARE IN Ω .
 1000K Ω .
 CAPACITOR VALUES ARE IN μ F UNLESS OTHERWISE NOTED. P=PPF.
 TAGS AT NO SIGNAL UNLESS OTHERWISE NOTED.
 REQUIREMENTS COMPONENTS IN ACCORDANCE WITH PRESENT
 REGULATIONS. THESE COMPONENTS MUST ONLY BE REPLACED
 WITH EQUIVALENT PARTS.

BACK SIGNAL
 RECORDING SIGNAL
 ERASE SIGNAL

SCHEMATIC DIAGRAM (2)

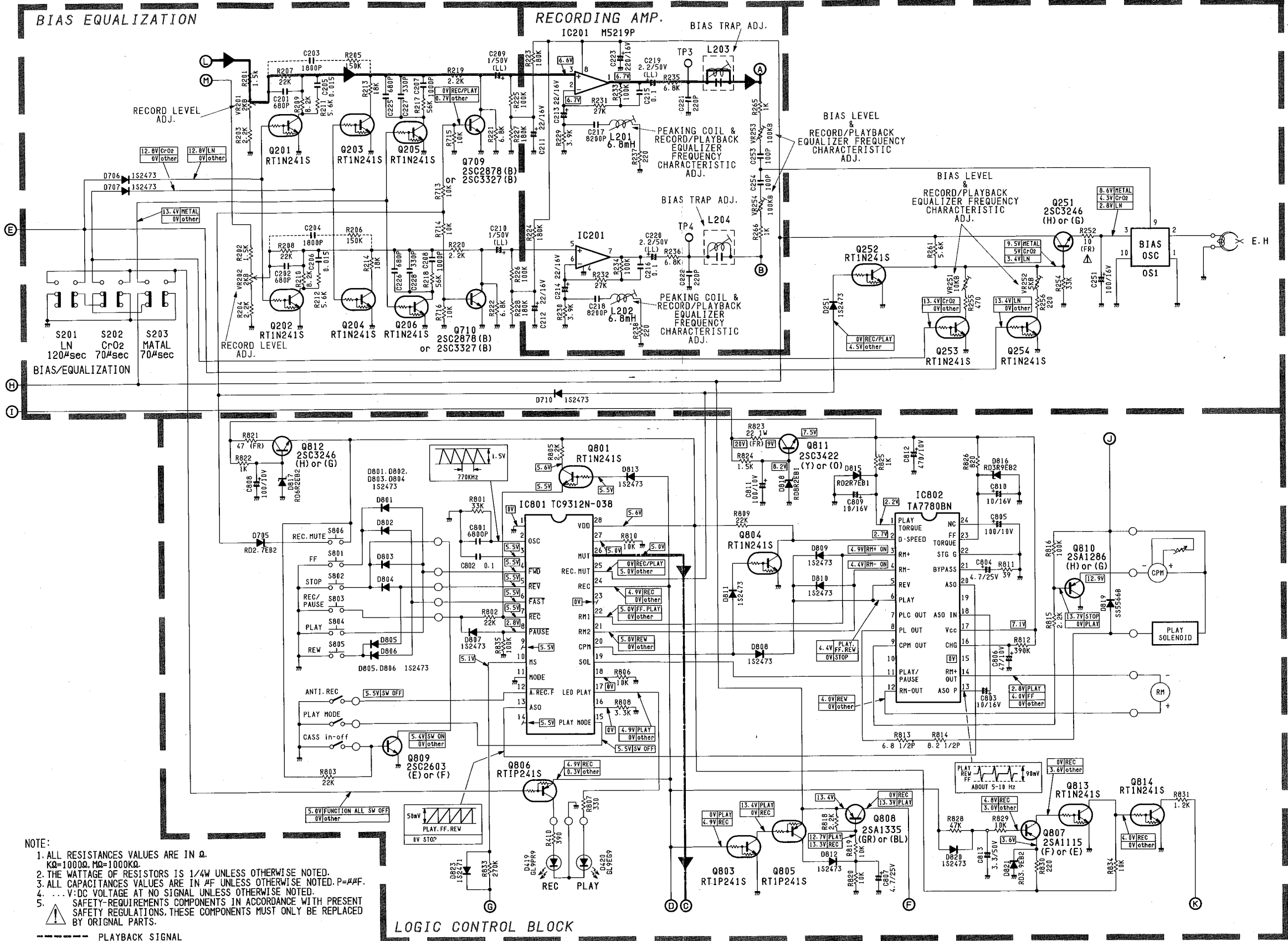

NOTE:

1. ALL RESISTANCES VALUES ARE IN Ω .
K Ω =1000 Ω , M Ω =1000K Ω .
2. THE WATTAGE OF RESISTORS IS 1/4W UNLESS OTHERWISE NOTED.
3. ALL CAPACITANCES VALUES ARE IN μ F UNLESS OTHERWISE NOTED. P= μ F.
4. ... V:DC VOLTAGE AT NO SIGNAL UNLESS OTHERWISE NOTED.
5. SAFETY-REQUIREMENTS COMPONENTS IN ACCORDANCE WITH PRESENT SAFETY REGULATIONS. THESE COMPONENTS MUST ONLY BE REPLACED BY ORIGINAL PARTS.

PLAYBACK SIGNAL
 RECORDING SIGNAL
 MUTING SIGNAL

SCHEMATIC DIAGRAM (2)

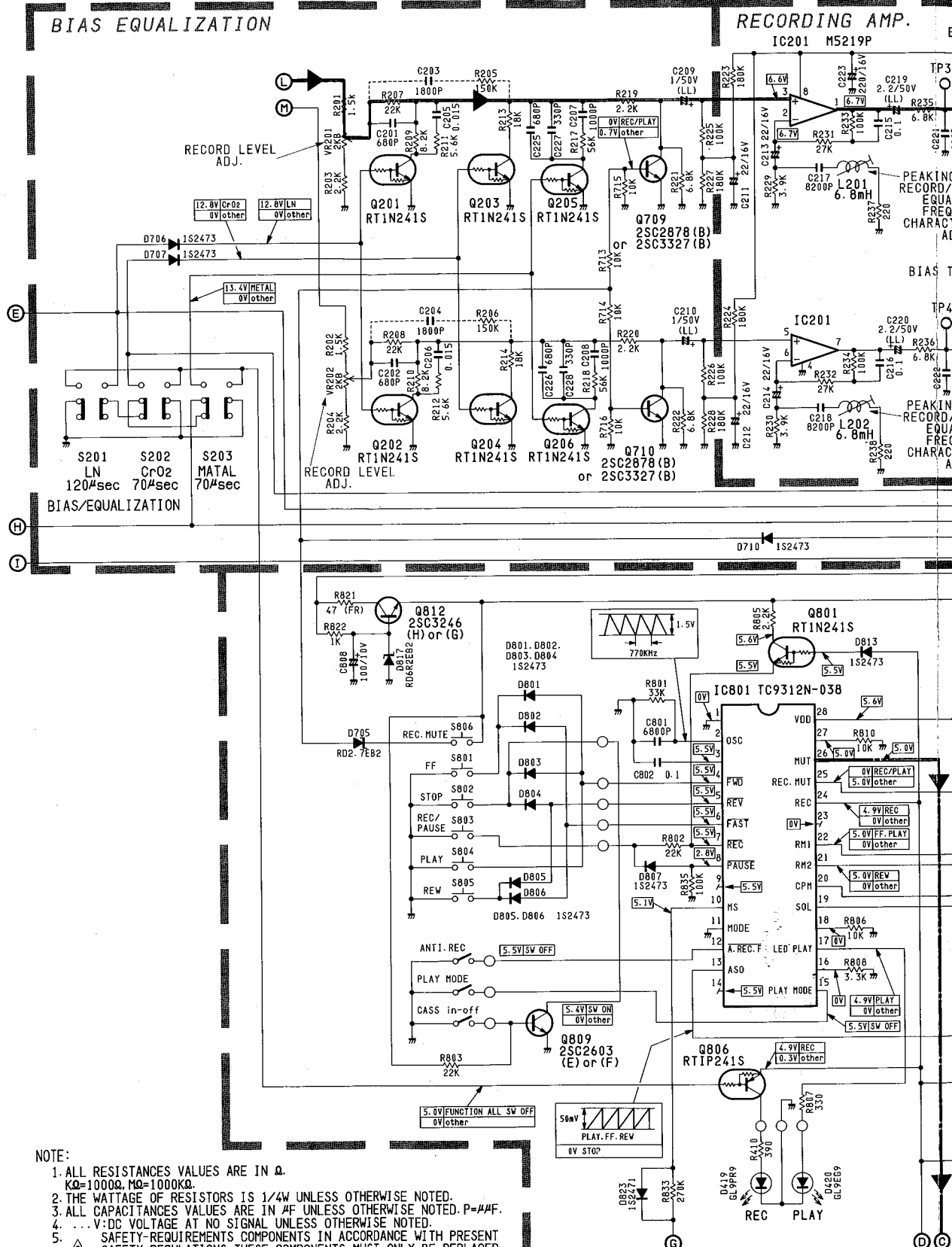

NOTE:

1. ALL RESISTANCES VALUES ARE IN Ω .
K=1000 Ω , M=100K Ω .
2. THE WATTAGE OF RESISTORS IS 1/4W UNLESS OTHERWISE NOTED.
3. ALL CAPACITANCES VALUES ARE IN μ F UNLESS OTHERWISE NOTED. P=PPF.
4. ...V:DC VOLTAGE AT NO SIGNAL UNLESS OTHERWISE NOTED.
5. SAFETY-REQUIREMENTS COMPONENTS IN ACCORDANCE WITH PRESENT SAFETY REGULATIONS, THESE COMPONENTS MUST ONLY BE REPLACED BY ORIGINAL PARTS.

PLAYBACK SIGNAL
 RECORDING SIGNAL
 MUTING SIGNAL

WIRING DIAGRAM

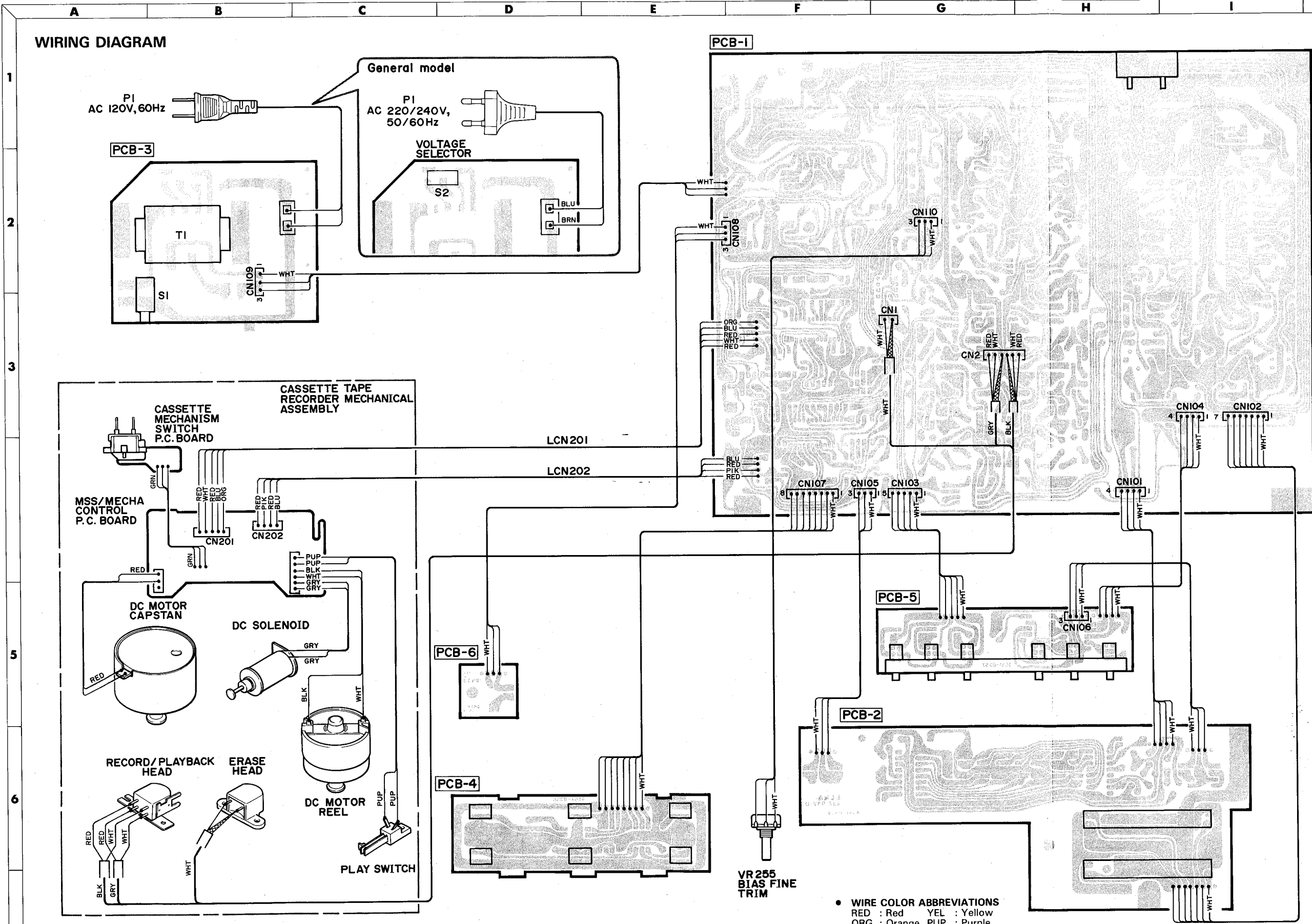

- WIRE COLOR ABBREVIATIONS
- | | |
|--------------|--------------|
| RED : Red | YEL : Yellow |
| ORG : Orange | PUP : Purple |
| BLU : Blue | PIK : Pink |
| WHT : White | GRY : Gray |
| GRN : Green | BRN : Brown |
| BLK : Black | |

VR 255
BIAS FINE
TRIM

1
2
3
4
5
6
7

WIRING DIAGRAM

1
2
3
5
6
7

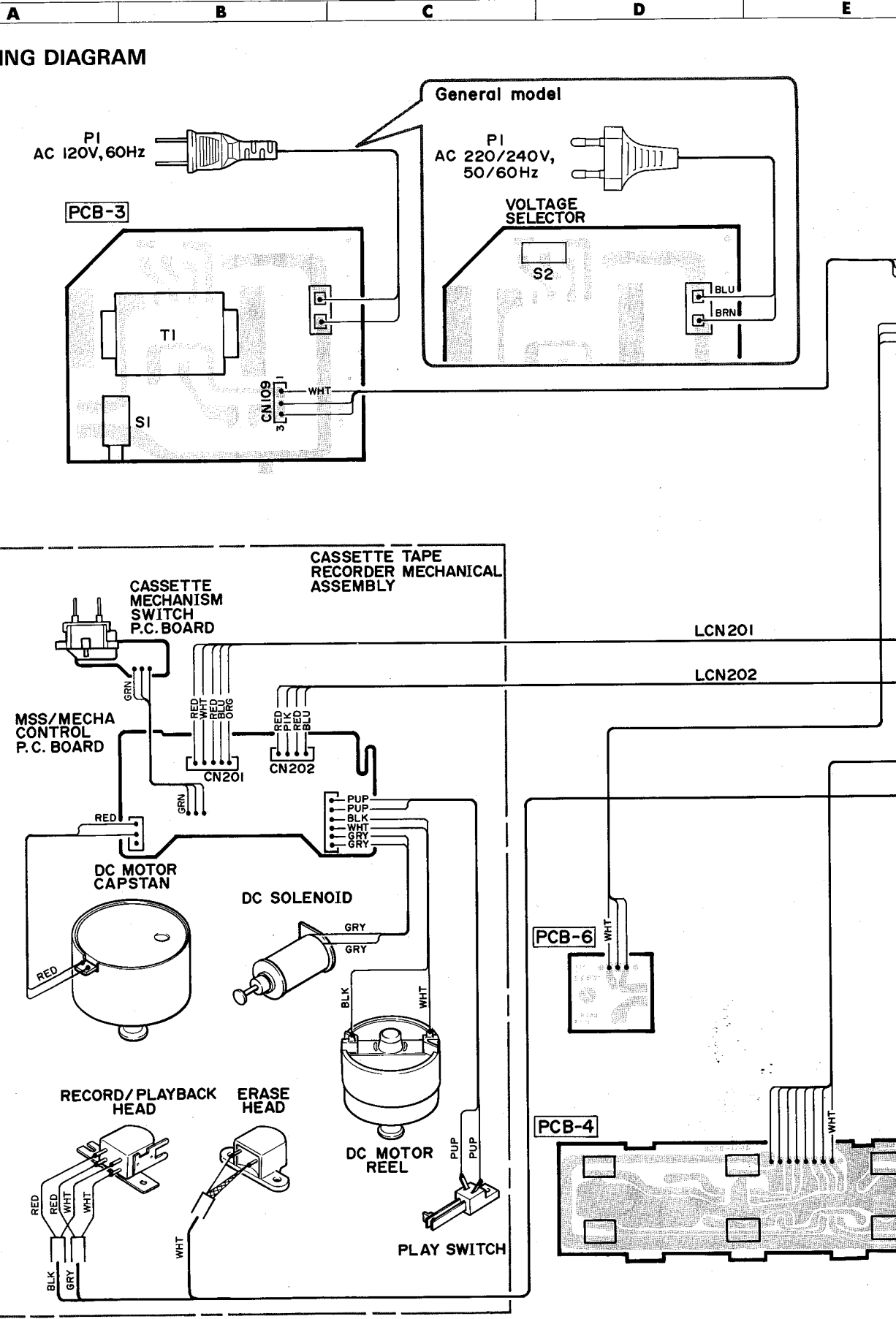

E F G H I J

PCB-1

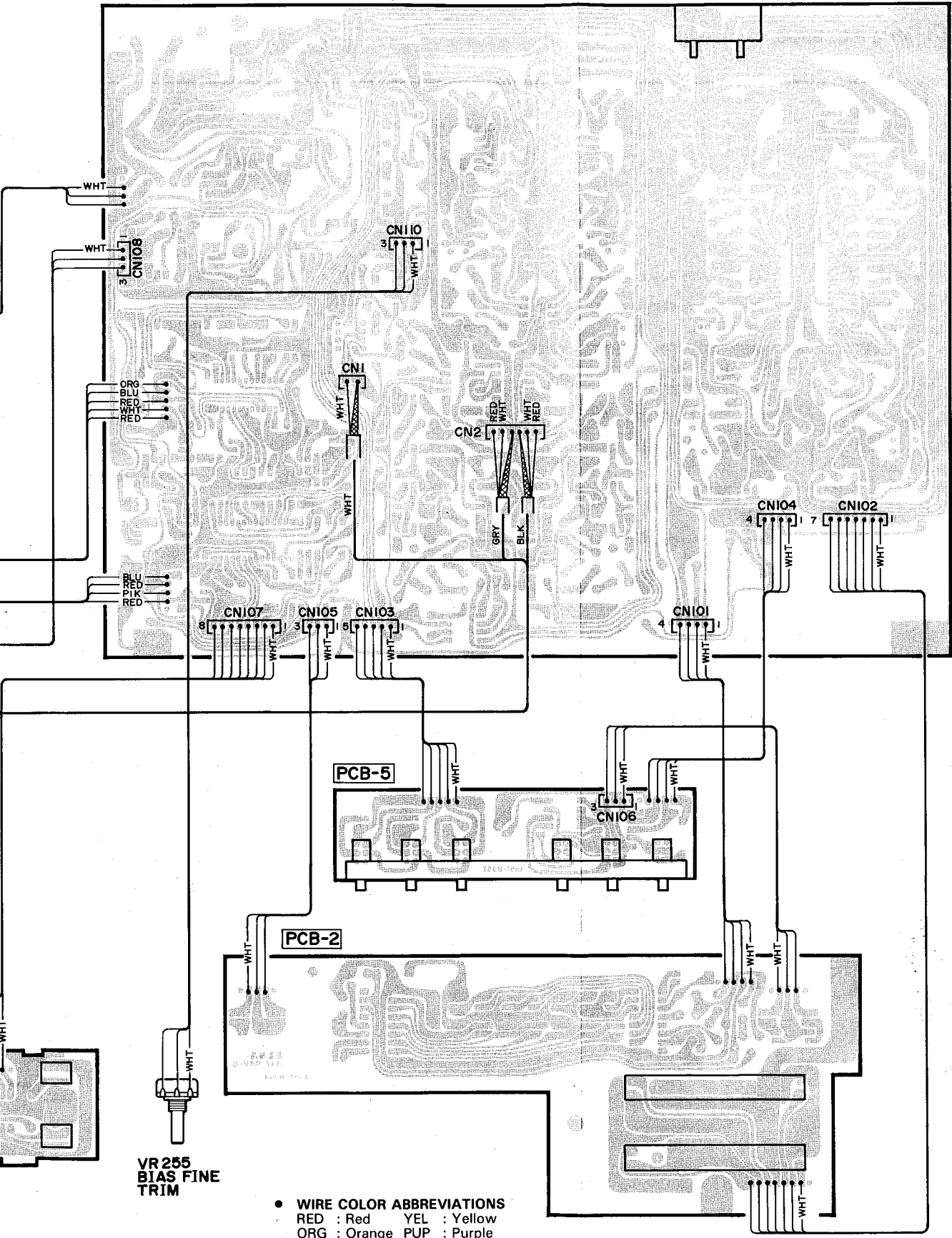

VR 255
BIAS FINE
TRIM

- WIRE COLOR ABBREVIATIONS
- RED : Red YEL : Yellow
- ORG : Orange PUP : Purple
- BLU : Blue PIK : Pink
- WHT : White GRY : Gray
- GRN : Green BRN : Brown
- BLK : Black

A B C D E F G H I J

P. C. BOARDS (1)

1 PCB-1 Main P.C. Board

2
3
4
5
6
7

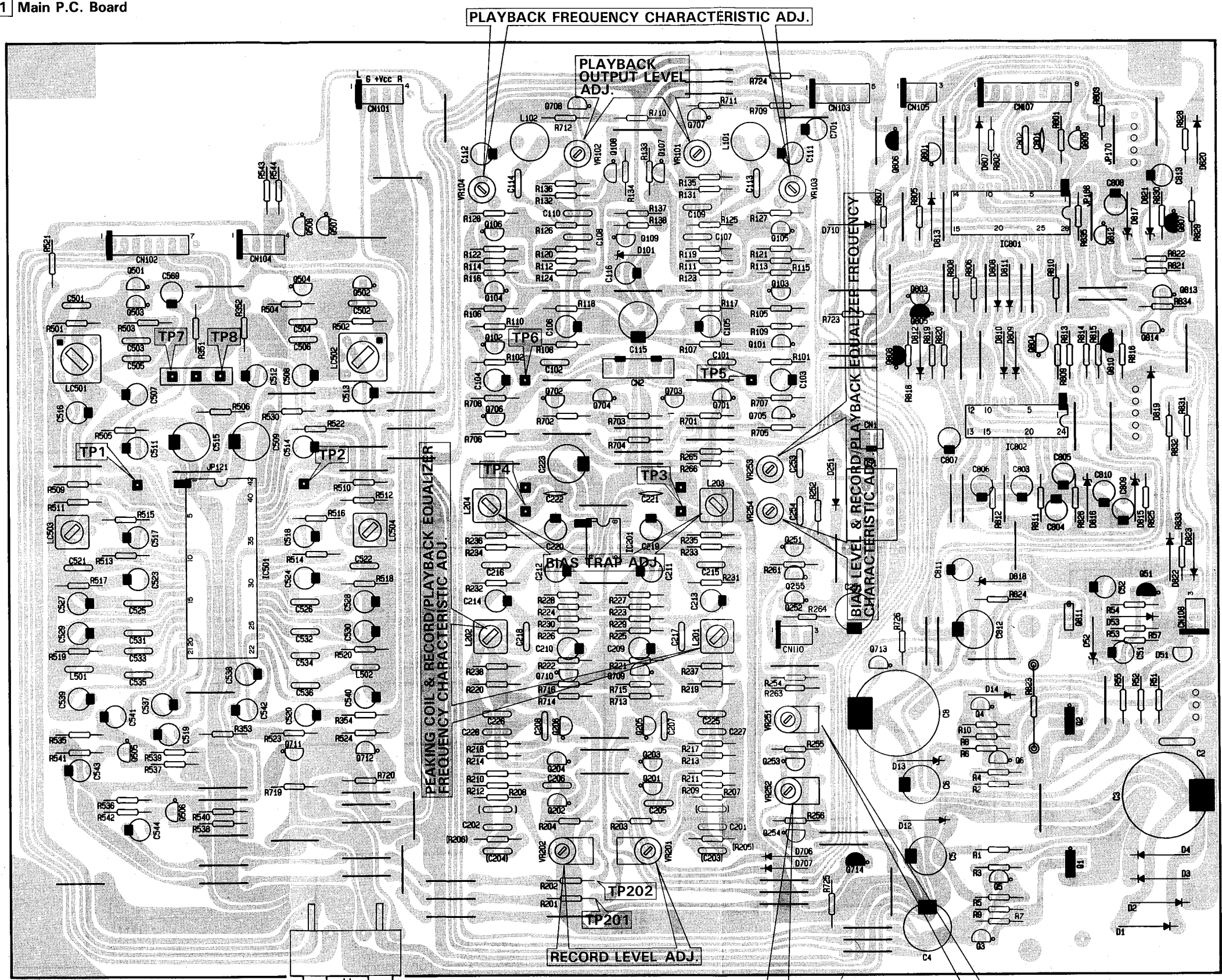

INPUT OUTPUT
LEFT RIGHT LEFT RIGHT

BIAS LEVEL & RECORD/PLAYBACK EQUALIZER FREQUENCY CHARACTERISTIC ADJ.

P. C. BOARDS (1)

PCB-1 Main P.C. Board

1
2
3
4
5
6
7

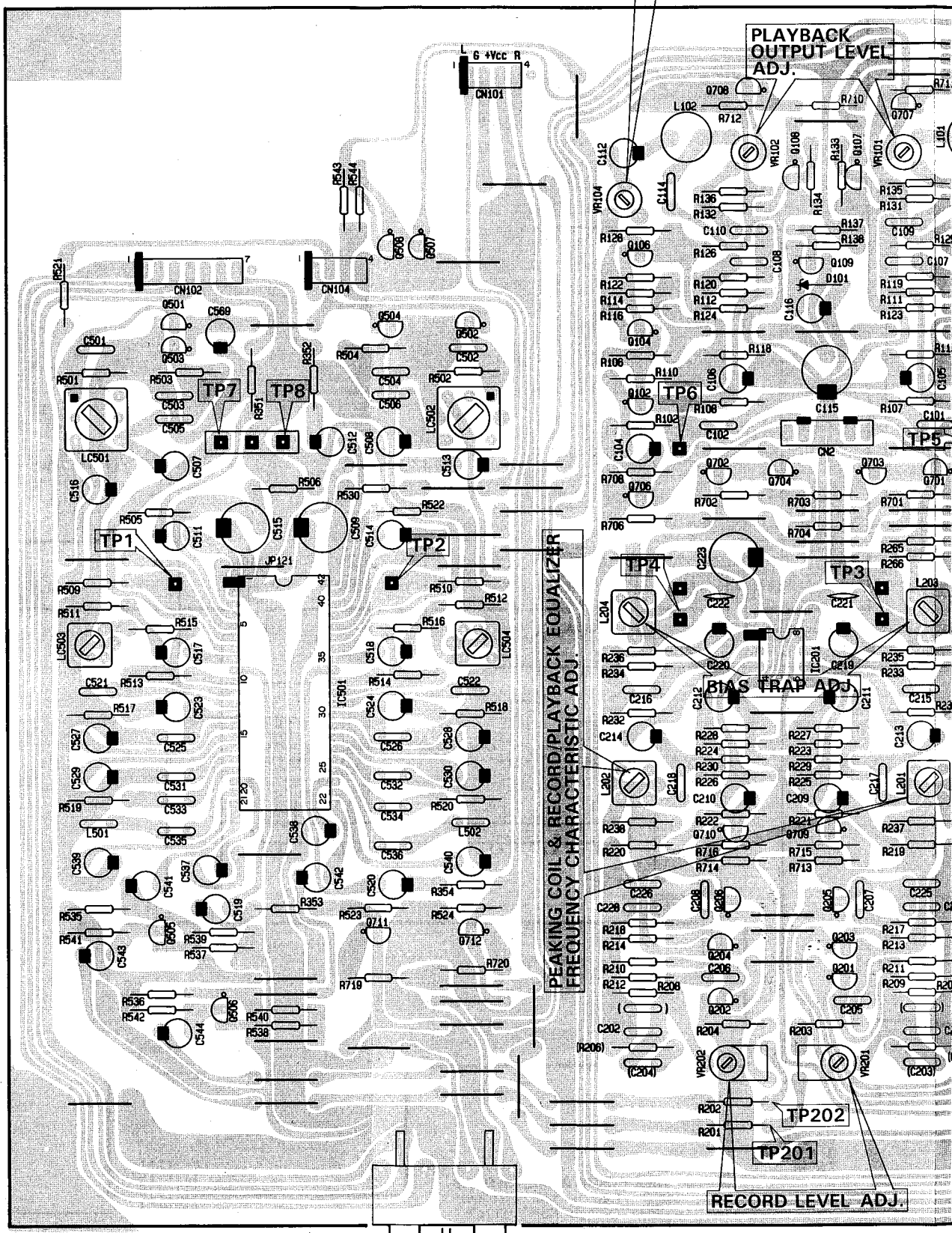

PLAYBACK FREQUENCY CHARACTER

PLAYBACK OUTPUT LEVEL ADJ.

PEAKING COIL & RECORD/PLAYBACK EQUALIZER FREQUENCY CHARACTER ADJ.

BIAS TRAP ADJ.

RECORD LEVEL ADJ.

BIAS LEV CHARAC

J1
INPUT LEFT OUTPUT RIGHT
LEFT RIGHT

ACTERISTIC ADJ.

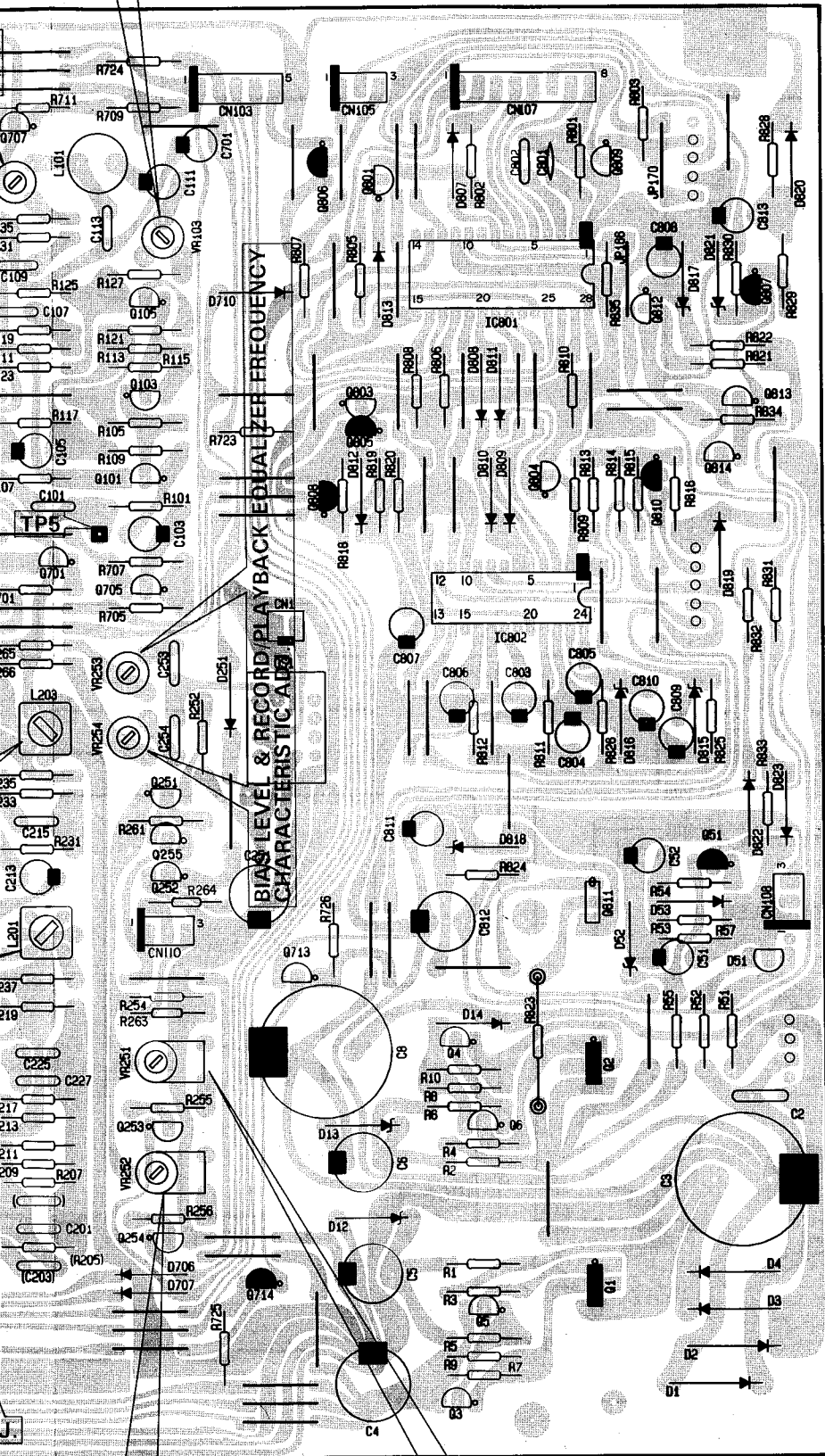

BIAS LEVEL & RECORD/PLAYBACK EQUALIZER FREQUENCY CHARACTERISTIC ADJ.

P. C. BOARDS (2)

PCB-2 Display P.C. Board

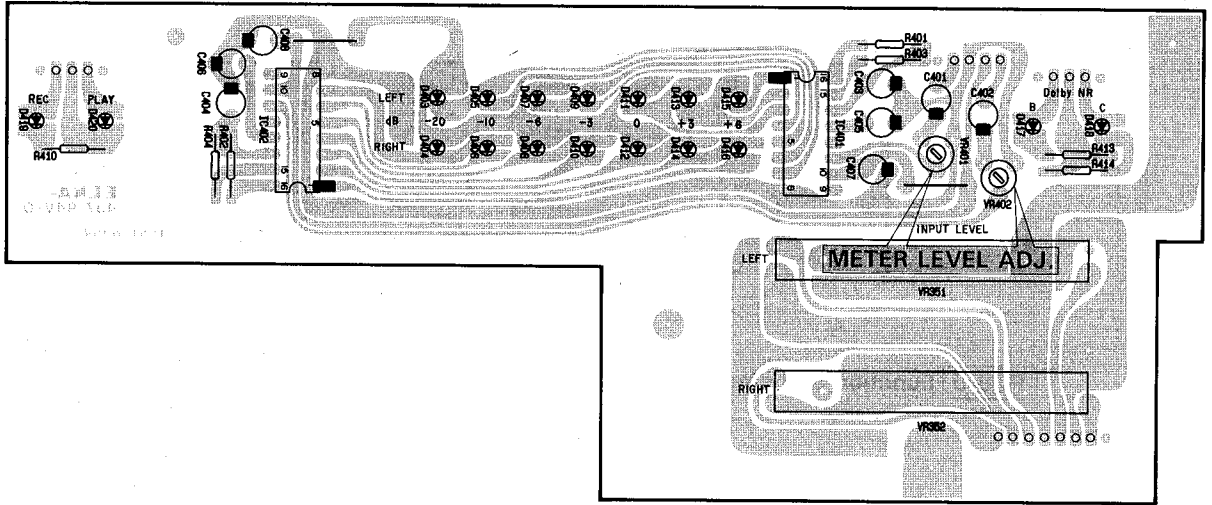

PCB-3 Power Supply P.C. Board

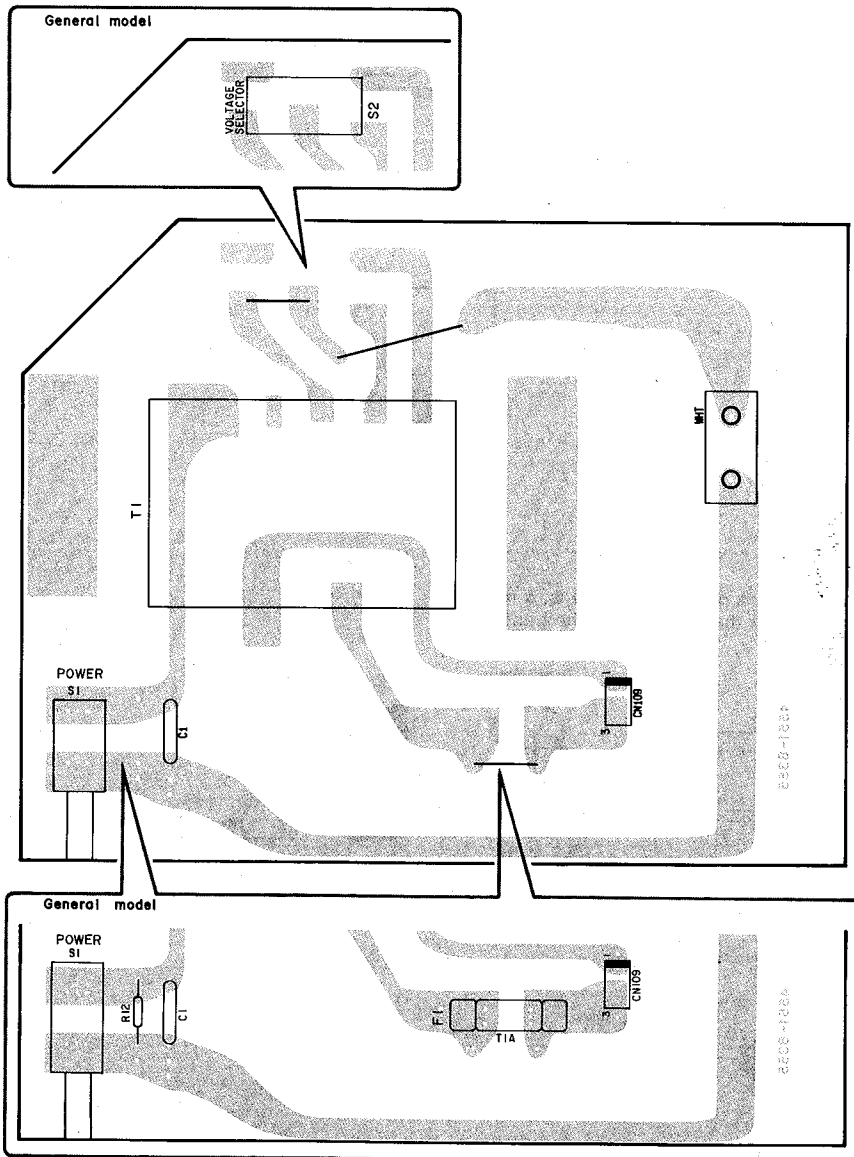

A B C D E

P. C. BOARDS (3)

1

PCB-4 Control Switches P.C. Board

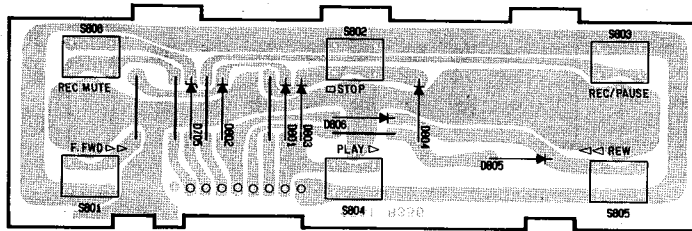

2

PCB-5 Function Switches P.C. Board

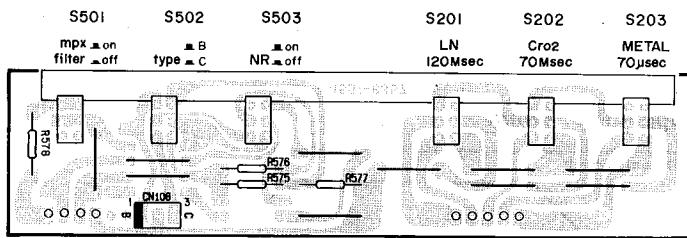

3

4

PCB-6 Power Ind. P.C. Board

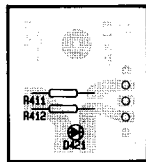

5

NOTE:

In the figures of the P. C. Boards, a mark is provided on the base side of the transistor.

6

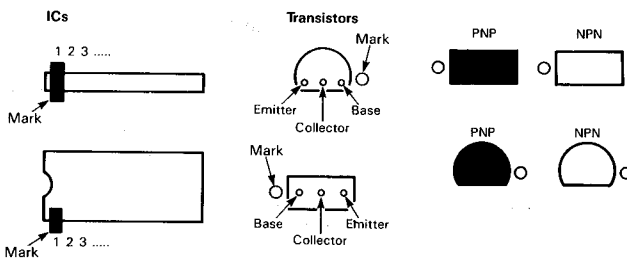

7

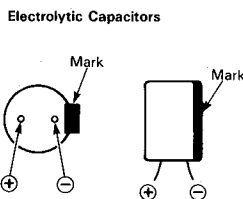

SCHEMATIC DIAGRAM (1)

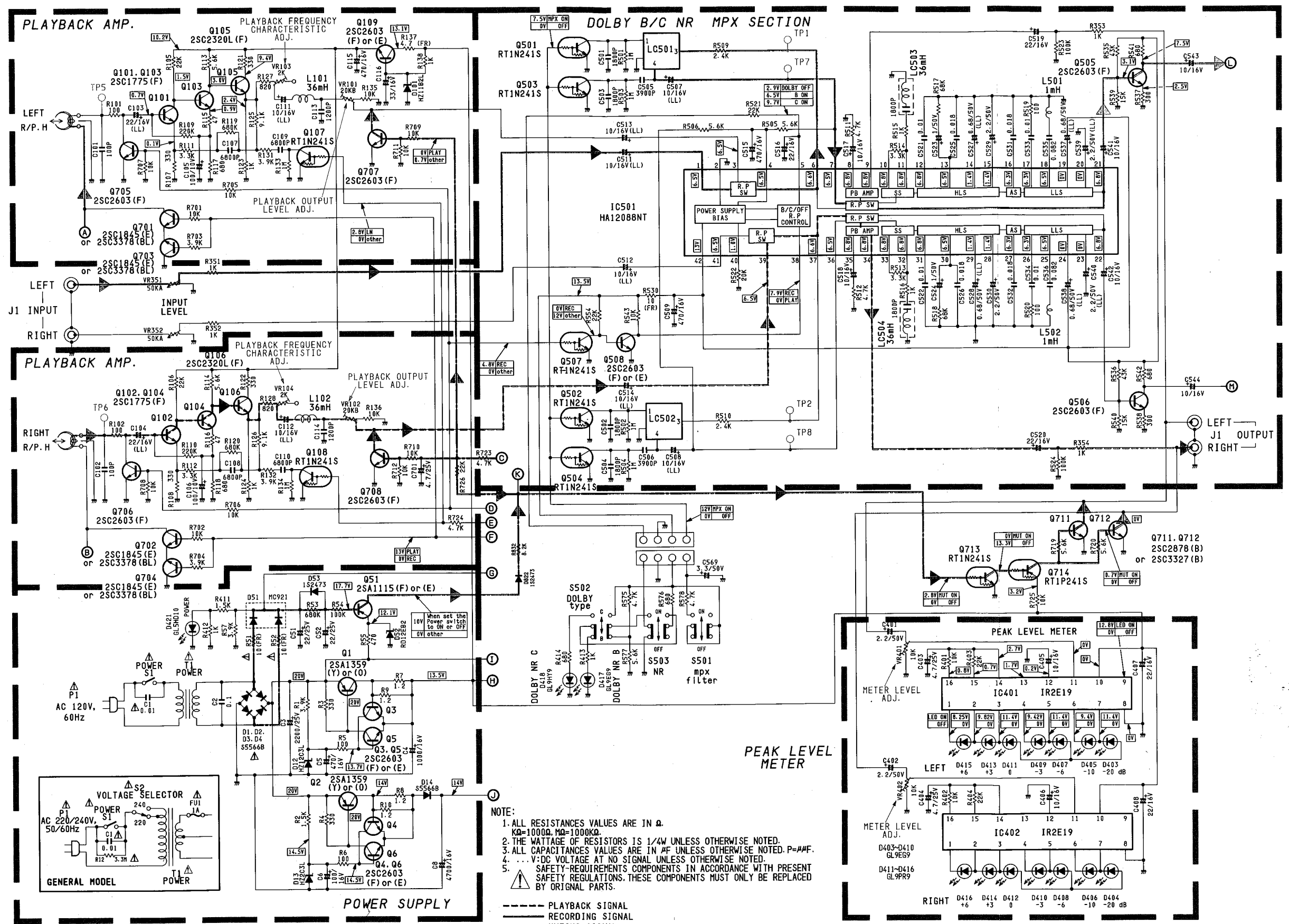

- NOTE:
1. ALL RESISTANCES VALUES ARE IN Ω .
K Ω =1000 Ω , M Ω =100K Ω .
 2. THE WATTAGE OF RESISTORS IS 1/4W UNLESS OTHERWISE NOTED.
 3. ALL CAPACITANCES VALUES ARE IN μ F UNLESS OTHERWISE NOTED. P=##F.
 4. ... V:DC VOLTAGE AT NO SIGNAL UNLESS OTHERWISE NOTED.
 5. SAFETY-REQUIREMENTS COMPONENTS IN ACCORDANCE WITH PRESENT SAFETY REGULATIONS. THESE COMPONENTS MUST ONLY BE REPLACED BY ORIGINAL PARTS.

- - - - - PLAYBACK SIGNAL
 - - - - - RECORDING SIGNAL
 - - - - - MUTING SIGNAL

SCHEMATIC DIAGRAM (1)

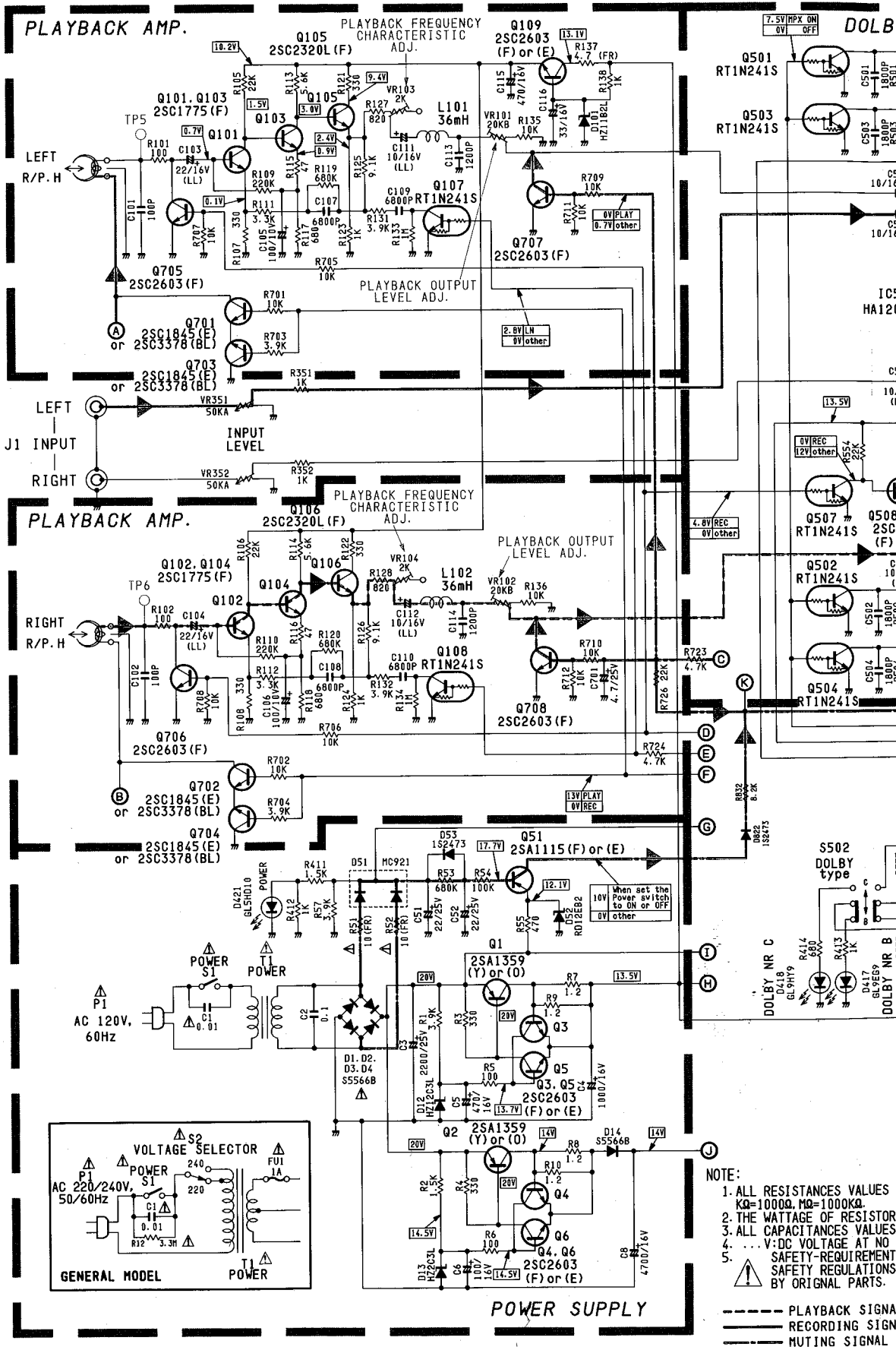

- NOTE:
1. ALL RESISTANCES VALUES
K=1000Ω, M=10000Ω.
 2. THE WATTAGE OF RESISTOR
 3. ALL CAPACITANCES VALUES
 4. ... V:DC VOLTAGE AT NO.
 5. SAFETY-REGULMENT
SAFETY REGULATIONS
BY ORIGINAL PARTS.

--- PLAYBACK SIGNAL
 --- RECORDING SIGNAL
 --- MUTING SIGNAL

1
2
3
4
5
6
7

SCHMATIC DIAGRAM (2)

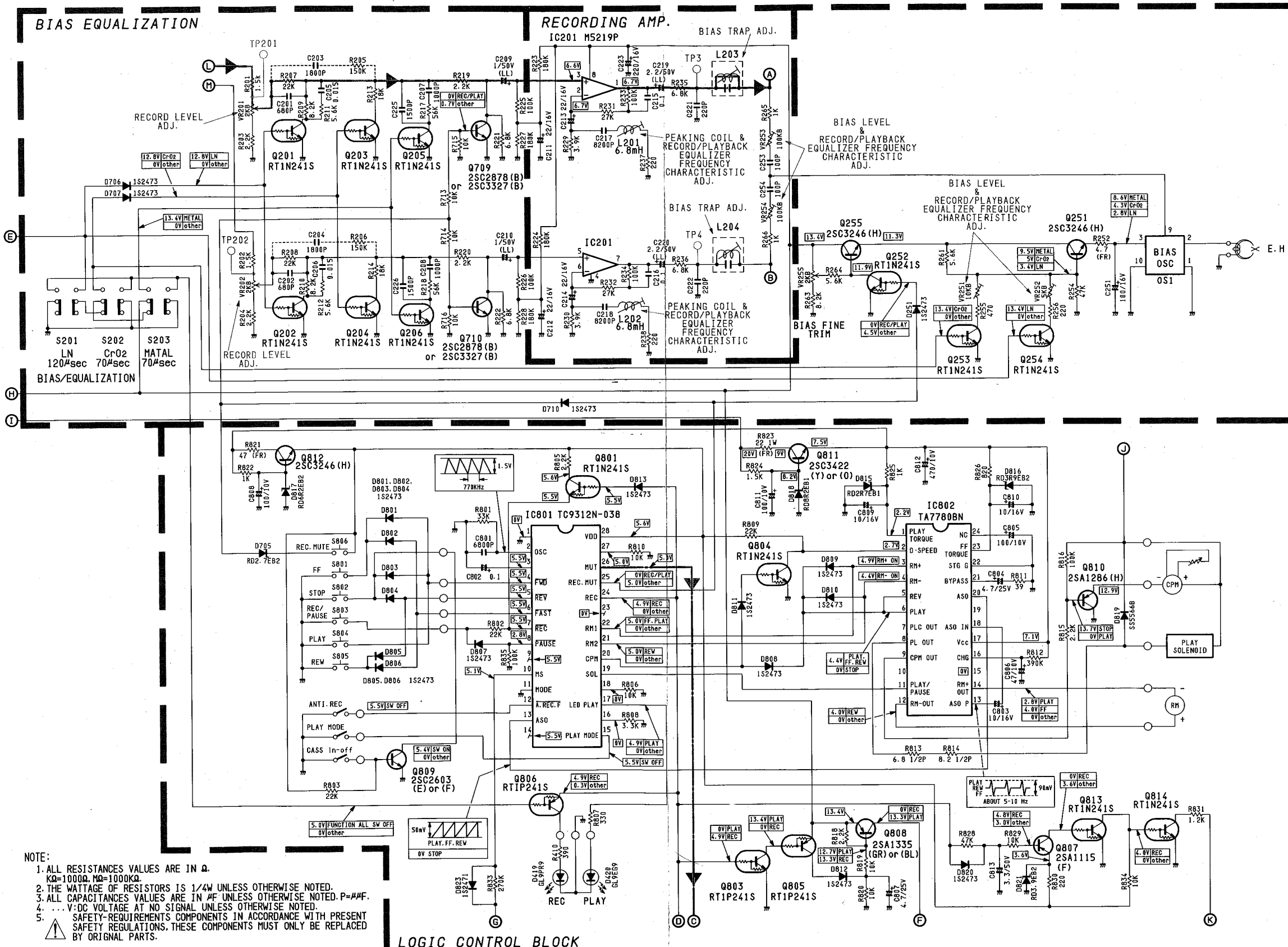

NOTE:
 1. ALL RESISTANCES VALUES ARE IN Ω .
 $K\Omega=1000\Omega$, $M\Omega=1000K\Omega$.
 2. THE WATTAGE OF RESISTORS IS 1/4W UNLESS OTHERWISE NOTED.
 3. ALL CAPACITANCES VALUES ARE IN μF UNLESS OTHERWISE NOTED. $P=MMF$.
 4. ... V: DC VOLTAGE AT NO SIGNAL UNLESS OTHERWISE NOTED.
 5. SAFETY-REQUIREMENTS COMPONENTS IN ACCORDANCE WITH PRESENT SAFETY REGULATIONS. THESE COMPONENTS MUST ONLY BE REPLACED BY ORIGINAL PARTS.

--- PLAYBACK SIGNAL
 --- RECORDING SIGNAL
 --- MUTING SIGNAL

SCHEMATIC DIAGRAM (2)

BIAS EQUALIZATION

RECORDING AMP.
IC201 M5219P

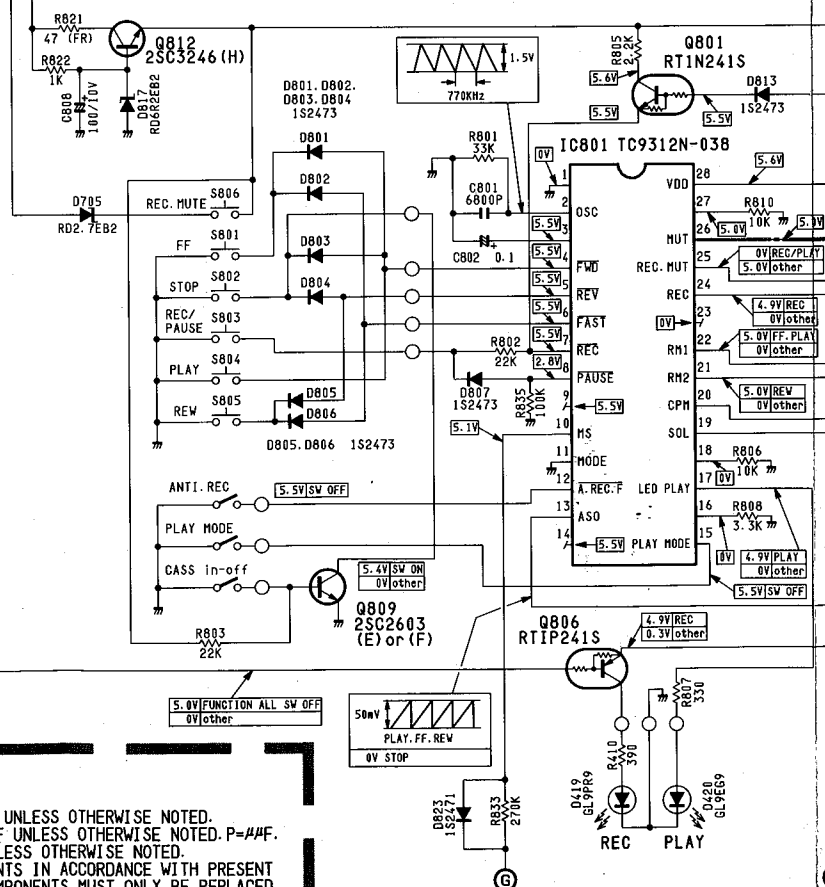
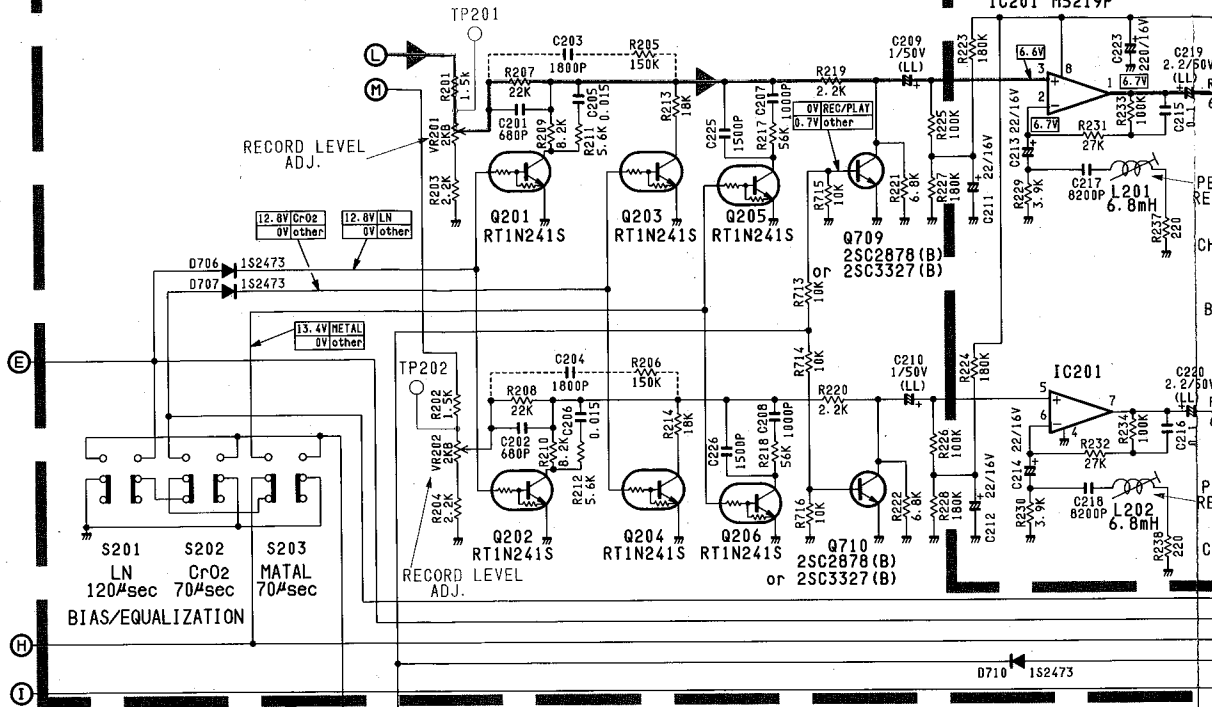

NOTE:

1. ALL RESISTANCES VALUES ARE IN Ω .
K Ω =1000 Ω , M Ω =1000K Ω .
2. THE WATTAGE OF RESISTORS IS 1/4W UNLESS OTHERWISE NOTED.
3. ALL CAPACITANCES VALUES ARE IN μ F UNLESS OTHERWISE NOTED. P= μ F.
4. ...V:DC VOLTAGE AT NO SIGNAL UNLESS OTHERWISE NOTED.
5. SAFETY-REQUIREMENTS COMPONENTS IN ACCORDANCE WITH PRESENT SAFETY REGULATIONS. THESE COMPONENTS MUST ONLY BE REPLACED BY ORIGINAL PARTS.

-----PLAYBACK SIGNAL
 _____RECORDING SIGNAL
 _____MUTING SIGNAL

LOGIC CONTROL BLOCK

AMP.

