

SPECIFICATIONS

Track Configuration	Nominal	Limit
	4-track 2 Channel Stereo	
	Cassette Deck	

● **MECHANICAL SECTION**

Record/Playback Tape Speed		
Deviation 4.75 cm/sec.	0.05% ±1.5%	
Drift 4.75 cm/sec.	0.2% ±1.5%	
Wow and Flutter	0.05% (NAB) ≤0.08%	
	0.08% (CCIR) ≤0.14%	
Take Up Torque	50gr. cm	35~70gr. cm
Back Tension	4gr. cm	2~6gr. cm
F.FWD Torque	100gr. cm	70~150gr. cm
REW. Torque	100gr. cm	70~150gr. cm
F.FWD/REW. Time (C-60 Tape)	90 sec.	≤100 sec.
Motor	Direct Drive motor	

● **AMPLIFIER SECTION**

Bias Frequency	105kHz ±5kHz
Playback Output	520mV ±1.5dB
Signal-to-Noise Ratio	
at Line Input (Input 1kHz, 100mV)	
IHF-A WTD at Dolby Level	
Dolby* NR Off	LN 51dB
	CrO ₂ 54dB
	Metal 54dB
Dolby B NR	LN 61dB
	CrO ₂ 64dB ≥60dB
	Metal 64dB ≥60dB
Dolby C NR	LN 66dB
	CrO ₂ 70dB ≥66dB
	Metal 70dB ≥66dB

*Dolby noise reduction manufactured under license from Dolby Laboratories Licensing Corporation. "Dolby" and the double-D symbol are trademarks of Dolby Laboratories Licensing Corporation.

Channel Separation	Nominal	Limit
	45dB	≥35dB
Crosstalk		70dB ≥60dB
Record/Playback Distortion (Input 1kHz)		
	LN	1.0% ≤1.6%
	CrO ₂	1.8% ≤3.0%
	Metal	1.0% ≤1.6%

MPX Filter Attenuation		
	at 15kHz	0.3dB ≤1dB
	at 19kHz	35dB ≥30dB
Erase Ratio (Input 80Hz)		
	LN	70dB ≥60dB
	Metal	61dB ≥56dB
Input Sensitivity (Input 1kHz) at Line Input		52mV 40(min)~100(max)mV
Input Impedance (Input 1kHz) at Line Input		23kΩ 19(min)~30(max)kΩ

● **DIMENSIONS (W x H x D)** 17-7/16" x 4-13/16" x 13-1/8" (443 x 122 x 334 mm)

● **WEIGHT** 12lbs. 9oz. (5.7kg)

● **POWER SUPPLY**
 U.S.A. & Canada models AC120V, 60Hz
 General model AC100/120/220/240V, 50/60Hz

● **POWER CONSUMPTION**
 U.S.A. & Canada models 18W
 General model 20W

Specifications and components subject to change without notice. Overall performance will be maintained or improved.

This specification is the target of servicing. But, there is a case that the specification is not applicable to the measurement condition and instrument.

LEAKAGE TEST (FOR SERVICE ENGINEERS IN THE U.S.A.)

Before returning the unit to the user, perform the following safety checks:

1. Inspect all lead dress to make certain that leads are not pinched or that hardware is not lodged between the chassis and other metal parts in the unit.
2. Be sure that any protective devices such as nonmetallic control knobs, insulating fishpapers, cabinet backs, adjustment and compartment covers or shields, isolation resistor-capacity networks, mechanical insulators, etc. which were removed for servicing are properly reinstalled.
3. Be sure that no shock hazard exists; check for leakage current using Simpson Model 229 Leakage Tester, standard equipment item No. 21641, RCA Model WT540A or use alternate method as follows: Plug the power cord directly into a 120-volt AC receptacle (do not use an Isolation Transformer for this test). Using two clip leads, connect a 1500 Ohm, 10-watt resistor paralleled by a 0.15 μF capacitor, in series with all exposed metal cabinet parts and a known earth ground, such as a water pipe or conduit. Use a VTVM or VOM with 1000 Ohms per volt, or higher, sensitivity to measure the AC voltage drop across the resistor. (See Diagram.) Move the resistor connection to each exposed metal part having a return path to the chassis (antenna, metal, cabinet, screw heads, knobs and control shafts, escutcheon, etc.) and measure the AC voltage drop across the resistor. (This test should be performed with the power switch in both the On and Off positions.)

A reading of 0.35volt RMS or more is excessive and indicates a potential shock hazard which must be corrected before returning the unit to the owner.

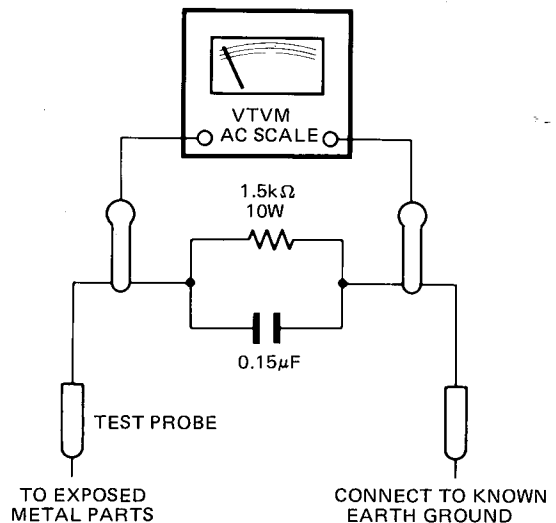
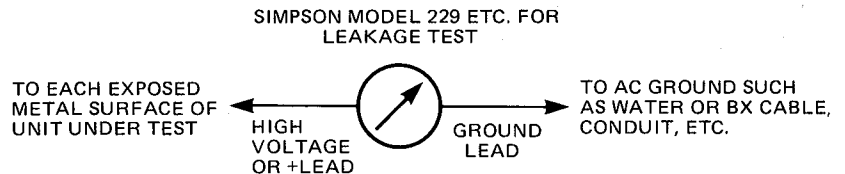

DISASSEMBLY PROCEDURES (REFER TO PAGES 5 AND 14)

1 CABINET TOP ASSEMBLY (101) REMOVAL

Remove 6 screws **A** and then remove the Cabinet Top Assembly (101).

2 FRONT PANEL ASSEMBLY (102) REMOVAL

1. Remove the Cabinet Top Assembly (101). (Refer to step 1.)
2. Remove 7 screws **B** and then remove the Front Panel Assembly (102).

3 CASSETTE TAPE RECORDER MECHANISM ASSEMBLY (113) REMOVAL

1. Remove the Front Panel Assembly (102). (Refer to step 2.)
2. Disconnect the LCN201 connected to the Cassette Tape Recorder Mechanism Assembly (113).
3. From the Record/Playback Head and Erase Head, unsolder the lead wires connected to the Main P. C. Board (PCB-1).
4. Loosen 8 screws **C** and then remove the Cabinet Bottom (128).
5. Remove the Belt (211) of the Tape Counter.
6. Remove 4 screws **D** and then remove the Cassette Tape Recorder Mechanism Assembly (113).

4 MAIN P. C. BOARD (PCB-1) REMOVAL

1. Remove the Cabinet Top Assembly (101). (Refer to step 1.)

2. Disconnect the LCN201 and LCN202 connected to the Cassette Tape Recorder Mechanism Assembly (113) and Peak Level Meter (D401).
3. Open the lid of connectors (CN103 ~ CN108, CN110, CN111, CN301 and CN302) on the Main P. C. Board (PCB-1) and disconnect the lead wires.
4. Unsolder the lead wires connected to the Main P. C. Board (PCB-1).
5. Remove 7 screws **E** and then remove the Main P. C. Board (PCB-1).

5 OTHER P. C. BOARDS REMOVAL

1. Remove the Front Panel Assembly (102). (Refer to step 2.)
2. Remove the Belt (211) of the Tape Counter.
3. Remove screw **F** and then remove the Plate Assembly (105) with the Dolby NR Ind. P. C. Board (PCB-6) and Rec./Pause Ind. P. C. Board (PCB-7).
4. Remove screw **G** and then remove the Function Switch P. C. Board (PCB-2). If necessary, unsolder the lead wires connected to the PCB-2.
5. Remove 2 screws **H** and then remove the Input Level Control P. C. Board (PCB-4). If necessary, unsolder the lead wires connected to the PCB-4.
6. Remove 2 screws **I** and then remove the VR P. C. Board (PCB-3) with the Bracket (184). If necessary, unsolder the lead wires connected to the PCB-3.

POWER CORD REPLACEMENT (FOR SERVICE ENGINEERS OTHER THAN NORTH AMERICA)

In order to prevent fire or shock hazard when replacing the power cord, follow the steps below to replace the parts with the standard supply parts.

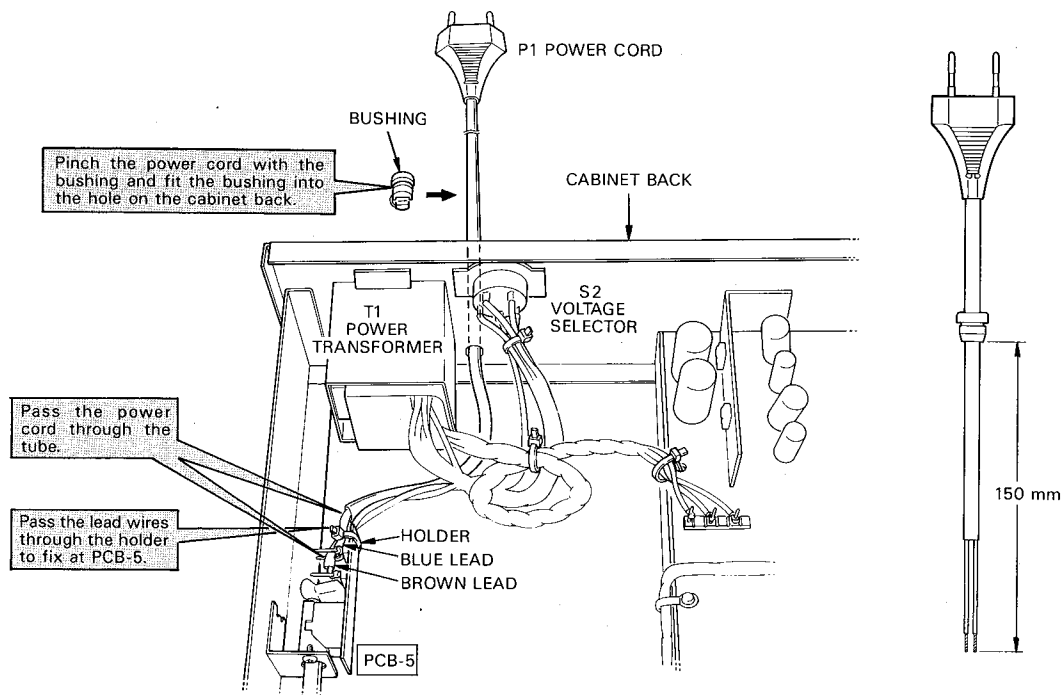

GENERAL UNIT PARTS LIST

Ref. No.	Part No.	Description
101	A414-TD292A	Cabinet Top Ass'y
102	A443-TD292A	Front Panel Ass'y
103	A453-TD292A	Sub-Panel Lid Ass'y
105	A513-TD292B	Plate Ass'y
106	A514-TD292A	Dressing Plate Ass'y
107	A632-TD292A	Knob Ass'y
108	A642-TD292A	Knob Ass'y
109	A662-TD292A	Push Button Ass'y
110	A662-TD292B	Push Button Ass'y
111	A662-TD292C	Push Button Ass'y
112	B211-TD292A	Chassis Ass'y
113	3112-12802	Cassette Tape Recorder Mechanism Ass'y
124	1319-0139	Foot
128	1423-02301	Cabinet Bottom
129	1424-15603	Cabinet Back U A
129	1424-15604	Cabinet Back EW
131	1442-10901	Panel, Input Level
139	1514-17002	Dressing Plate
143	1531-08501	Door Cover
154	1660-00401	Push Button, Power
155	1660-00501	Push Button, Eject
158	1660-00801	Push Button, REC, FF, REW, Stop, Pause, REC Mute
159	1660-00901	Push Button, Play
175	2114-01224	Bushing
181	2215-7005	Bracket
182	2219-7091	Bracket
183	2219-8048	Bracket
184	2219-8049	Bracket
185	2219-8050	Bracket
186	2219-8051	Bracket
187	2219-8052	Bracket
188	2219-7755	Bracket
194	2222-7186	Heat Sink
195	2222-7067	Heat Sink
196	2240-364	Holder
197	2240-7120	Holder
204	2430-7008	Special Fastener
209	2601-7156	Shaft, Power Switch
211	2642-01440	Belt
213	2651-210189	Spring
214	2651-2101721	Spring
216	2674-7020	Slider
219	2310-7025	Special Screw
227	2327-200429	Screw (2 x 4mm)
233	2343-300627	Screw (3 x 6mm)
235	2347-300842	Screw (3 x 8mm)
239	2347-300627	Screw (3 x 6mm)
243	2347-300827	Screw (3 x 8mm)
245	2347-300647	Screw (3 x 6mm)
247	2347-400647	Screw (4 x 6mm)
251	2440-7017	Special Nut EW
252	2132-01406	Spacer EW
	1111-J30217	Owner Guide U
	1111-J30218	Owner Guide A EW
	1221-727181	Packing Box
	1222-7284	Packing Cushion

CASSETTE TAPE RECORDER MECHANISM
PARTS LIST

Ref. No.	Part No.	Description
1	F245-011	Switch Arm, Pack
2	F244-011	Switch Arm, REC
3	FD35C-11	Cassette Support
4	FK568-11	Spring, Door
5	EC30K-12	Eject Lock Arm
6	FM296-11	Spacer
7	KY130-11	Connector, 8 Pos.
8	UE13K-11	Switch
9	FU14K-11	REC/PB Head
10	FU192-11	Erase Head
11	FK572-11	Spring, Azimuth
12	FD23C-15	Head Spacer
13	F105-020	Supply Reel Ass'y
14	F123-033	Take-up Reel Ass'y
15	FC29K-11	Spring Holder
16	FC29N-13	Head Base
17	FD24H-12	Brake Arm (L)
18	FD24K-12	Brake Arm (R)
19	FK18U-11	Spring, Brake
20	F014-075	Pinch Roller
21	FK18S-11	Spring, Pinch Roller
22	FK18V-11	Spring, Solenoid Arm
23	FK18T-14	Spring, Assist
24	FK11F-47	Spring, Back Tension
25	FN14B-12	Idler Gear
26	FK18M-11	Spring, Eject Arm
27	F011-163	Chassis Ass'y
28	FC29E-11	Spring, Cassette
29	F265-216	Solenoid, FF, REW
30	FR17M-13	Clutch Ass'y
31	FC29F-11	Bracket, Dumper
32	FP472-11	Dumper Ass'y
33	FD23B-12	FF/REW Solenoid Arm
34	FP463-11	Sub Belt
35	FF14A-11	Main Belt
36	F265-217	Solenoid, PB
37	FD23E-12	PB Arm
38	FK18W-12	Spring, PB Arm
39	FR17N-11	Idler Ass'y
40	FK18R-12	Spring, Idler
41	FC29G-14	Bracket, Door
42	FK18N-11	Spring, Head Base
43	FK18P-11	Spring, Assist Base
44	FC29M-12	Assist Base
45	FN14C-13	PB Gear
46	FD24G-12	Collar
47	FK11F-51	Spring, Flywheel
48	FR17E-11	Flywheel Ass'y
49	UJ11S-11	Spacer
50	WH20C-01	Connector, 4 Pos.
51	FC29H-15	Bracket, Motor
52	F064-179	Motor
53	FP12T-12	Connector Panel
54	FJ115-12	Cushion, Motor

- U** : U.S.A. model
A : Canada model
EW : General model

* The part with the above mark is used only in the model made for the particular market the mark indicates.

A B C D E
GENERAL UNIT EXPLODED VIEW

1
2
3
4
5
6
7

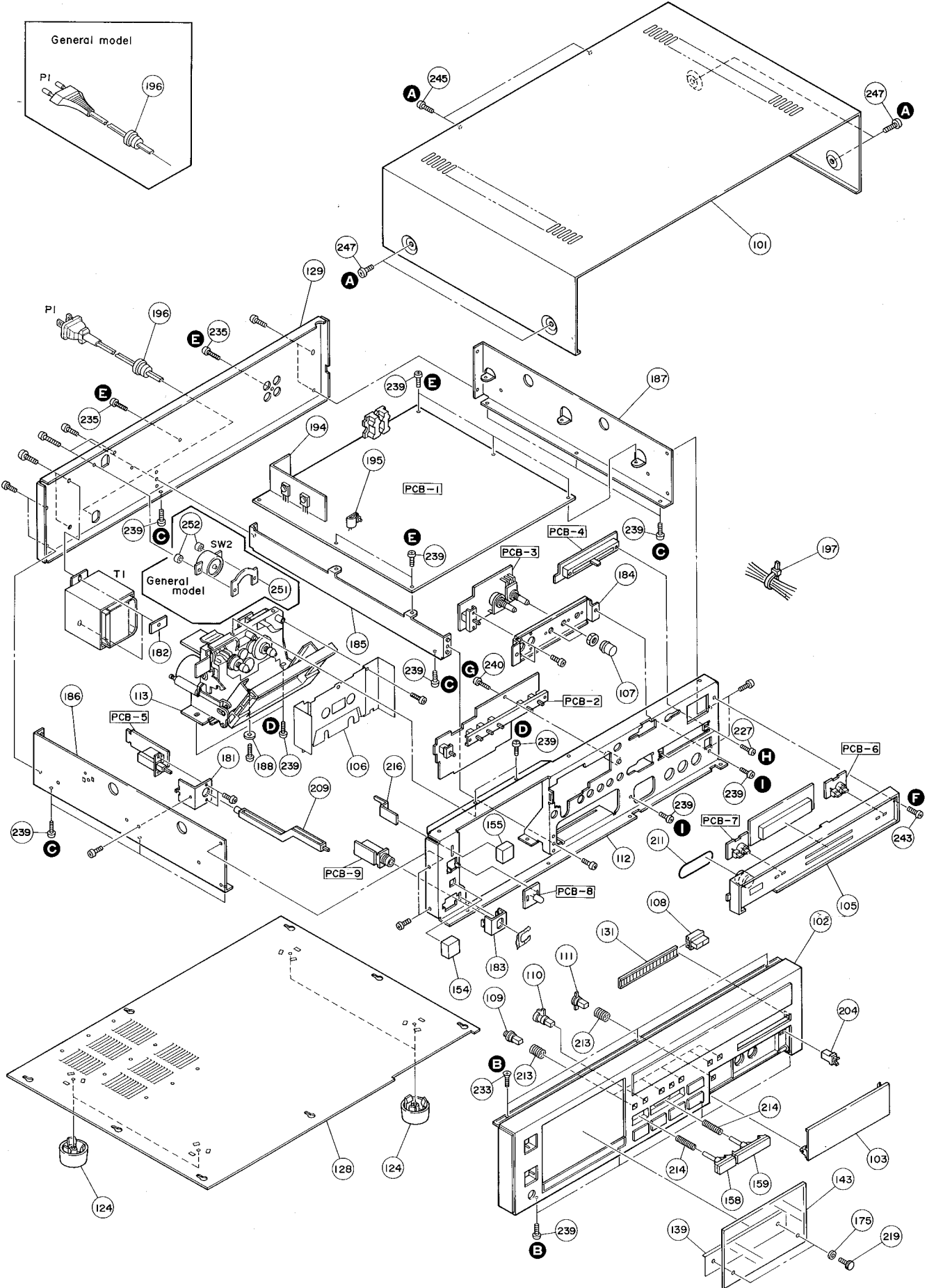
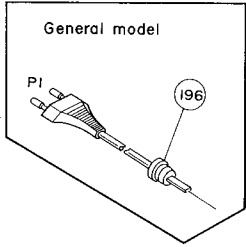

A B C D E
CASSETTE TAPE RECORDER MECHANISM EXPLODED VIEW

1
2
3
4
5
6
7

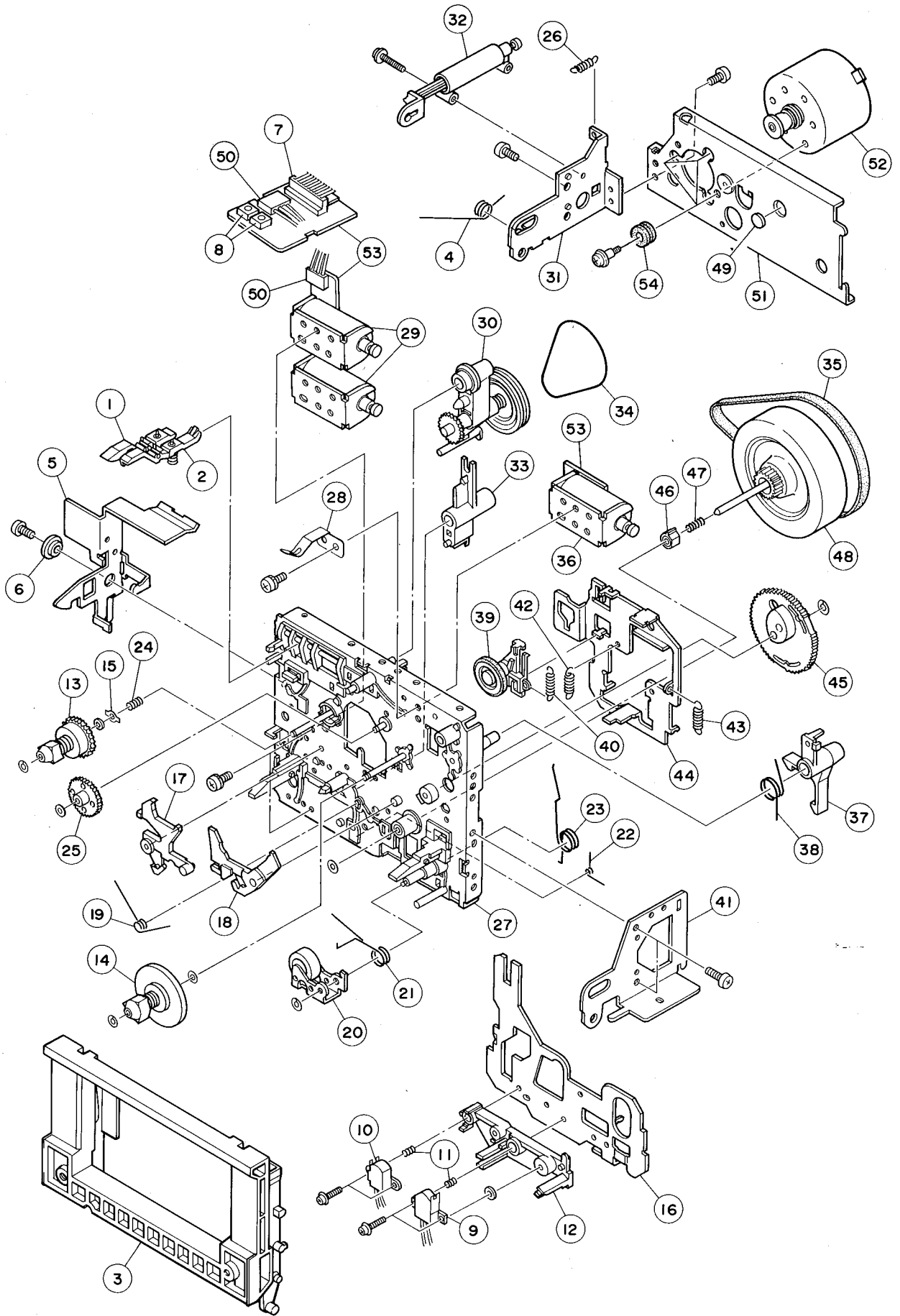

CIRCUIT DESCRIPTION

Playback Signal

The playback signal taken out of the playback head is amplified in the Q101, Q103, Q105 (L ch.), Q102, Q104 and Q106 (R ch.) and it is fed to the Dolby NR circuit consisting of the IC501 and IC502.

Then the signal enters ④ pin of the IC501 (L ch.) and IC502 (R ch.) where they are encoded and output through ⑫ pin. The output signal is divided into monitor output and meter output, and the monitor output signal is fed to OUTPUT jack and the headphone amplifier of the IC301.

The characteristics of the playback equalizer are specified by tape selector (BIAS/EQUALIZATION), and selected and specified in the Q107 (L ch.) and Q108 (R ch.).

Record Signal

The input signal coming through INPUT jack is adjusted by INPUT LEVEL and INPUT BALANCE and fed to the Dolby NR circuit consisting of the IC501 and IC502.

Then the signal passes through the Q501 (L ch.) and Q502 (R ch.) and by way of the MPX filters of the LC501 (L ch.) and LC502 (R ch.), it enters ① pin of the IC501 (L ch.) and IC502 (R ch.) where it is decoded and output through ⑭ pin.

The output signal passes through the record equalizer circuit, amplified in the record amplifier of the IC201, combined with the bias signal and fed to the record head.

Muting Operation

The Record/Playback switch control signal and mute signal are output from the IC801 of the logic control block.

The signal output through ⑨ pin of the IC801 turns Q804 and 805 ON, whereby the mute signal is output. At the power ON/OFF, however, the mute signal is output from Q51. When the STOP button is pressed, this mute signal is output to turn ON the Q711 (L ch.) and Q712 (R ch.) to short-circuit the output signal for muting.

Logic in Record Mode

When the REC button is pressed, ⑮ pin of the IC801 becomes low level to cause the Q801 and Q802 to turn ON, and $\overline{\text{REC}}$ and REC signals are output. The $\overline{\text{REC}}$ signal causes the bias circuit to turn ON and the REC signal causes the Q705, 707 (L ch.) and Q706 and 708 (R ch.) to turn ON to short-circuit the input and output signals of the playback amplifiers.

Also, the REC signal causes the Q803 to turn OFF. As the PLAY signal turns OFF thereby, Q701, Q703 (L ch.), Q702, 704 (R ch.) and Q709 (L ch.), 710 (R ch.) turn off, resulting in the record mode.

Logic in Playback Mode

With the STOP, PAUSE or PLAY button pressed, the Q803 becomes ON (OFF when ⑮ pin of the IC801 is low level), the PLAY signal is output and the Q701, 703 (L ch.) and Q702, 704 (R ch.) turn ON. Then the output side of the IC201 is short-circuited and at the same time one side of the record/playback head is short-circuited to the ground. Also, the Q709 (L ch.), 710 (R ch.) are turned ON to short-circuit the input side of the IC201, resulting in the playback mode.

BLOCK DIAGRAM

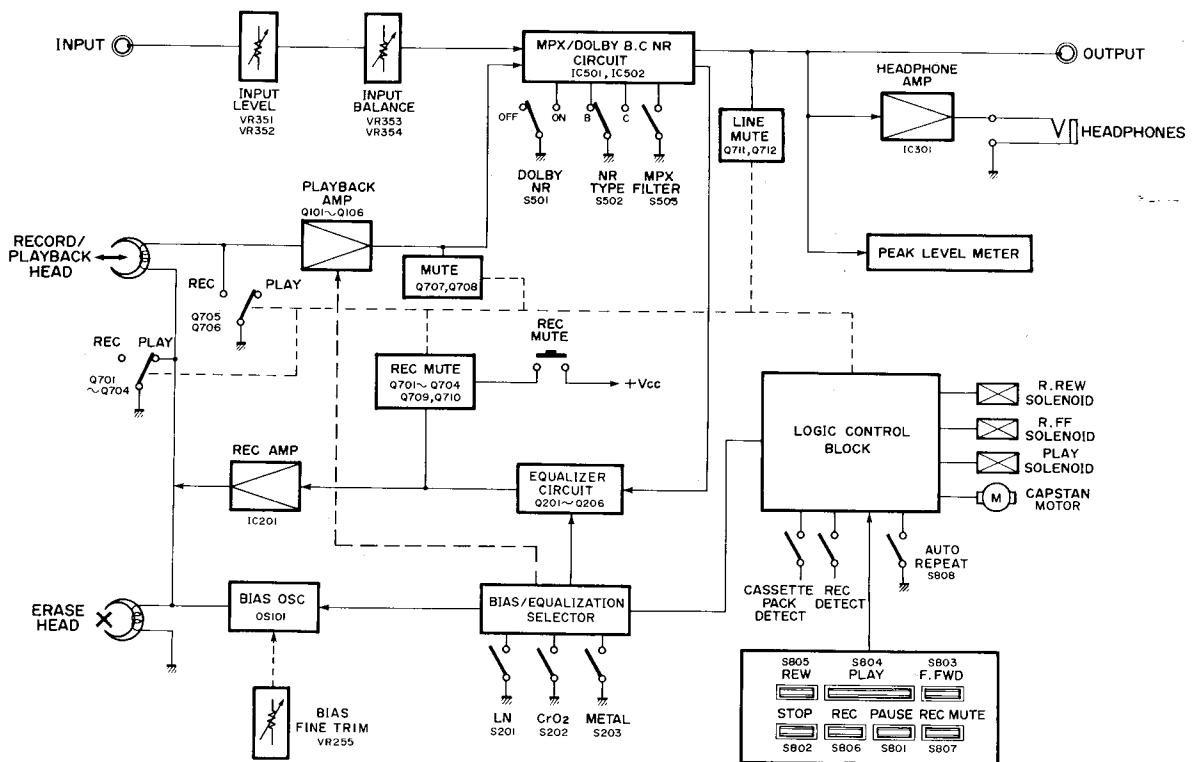

TIMING CHART

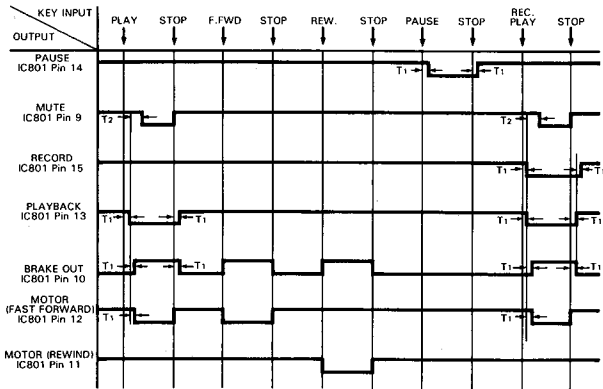

Fig. A

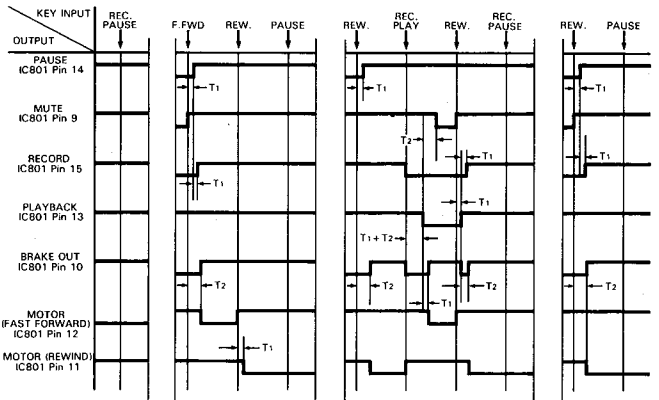

Fig. D

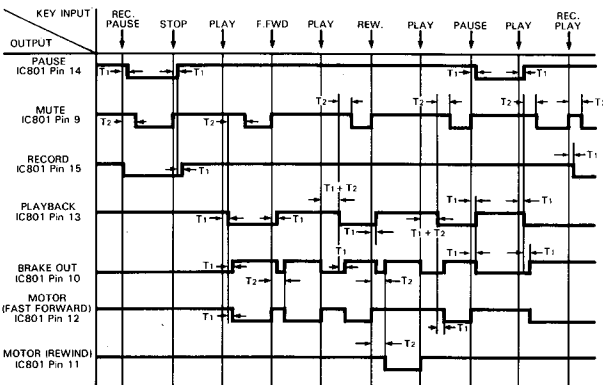

Fig. B

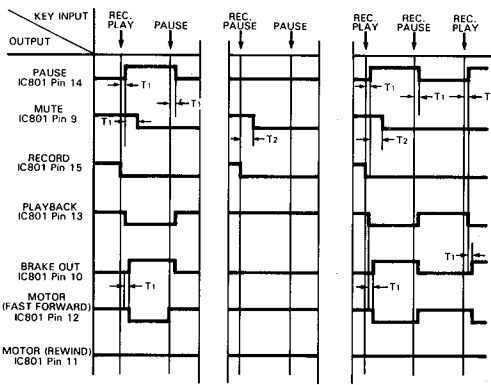

Fig. E

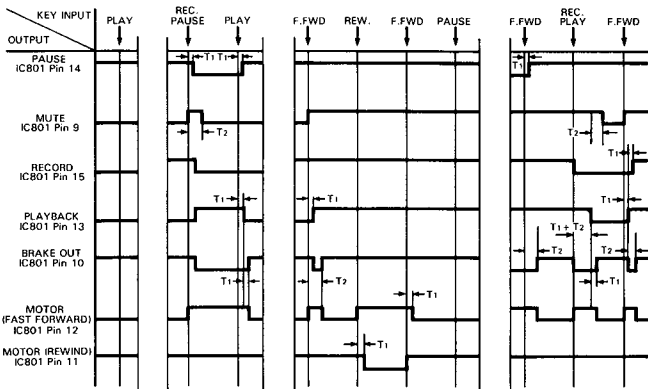

Fig. C

● AUTO REPEAT TIMING CHART

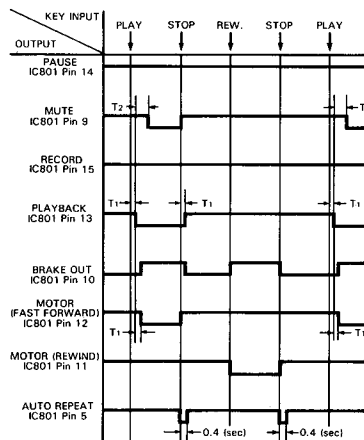

Fig. F

NOTE
After the power switch is pushed on, the unit remains in stop mode for about 1.6 second. After that, it operates according to each input key as shown figure. During this 1.6 second all input keys are ineffective.

T1 = 61 (msec)
T2 = 400 (msec)

ALIGNMENT PROCEDURES (REFER TO PAGES 11,12 AND 13)

■ CASSETTE MECHANISM CONFIRMATION

Make sure to confirm conditions of the cassette mechanism as follows before adjustment.

1. Confirmation of erroneous erase preventive function

- The switch should turn ON when a tape with erroneous erase preventive pawl is inserted. (Use a tape which is 0.2mm smaller than the minimum size of 62.9mm or a MAZ-0184-C gauge one.)
- When the switch arm is moved back gradually from the ON position, the switch should turn OFF.

2. Confirmation of cassette pack detection function

- The switch should turn ON when a tape is inserted. (Use a tape whose minimum size is 63.5mm or a MAZ-0184-C gauge one.)
- When the switch arm is moved back gradually from the ON position, the switch should turn OFF.

3. Confirmation of eject function

- The cassette compartment opens smoothly and no abnormal noise should be heard while opening and closing.
- The eject lock arm opens smoothly without contacting the chassis and damper.
- The eject button can not be pressed during playback.

4. Confirmation of playback, fast forward and rewind functions

- The torque used in each of the playback, fast forward and rewind modes should be within specification.
 - Playback 35gr. cm ~ 70gr. cm
 - Fast Forward 70gr. cm ~ 150gr. cm
 - Rewind 70gr. cm ~ 150gr. cm
- No abnormal noise should be heard during operation in any mode. The solenoid switching sound should not be considered as a noise.

5. Confirmation of positions of record/playback head and erase head

● Head height

- Set the M-300 head gauge.
- Set the unit in the playback mode and place the adjustment chip on the head gauge as shown in the Fig. 1.
- The adjustment chip should not contact the tape guide of both record/playback head and erase head.

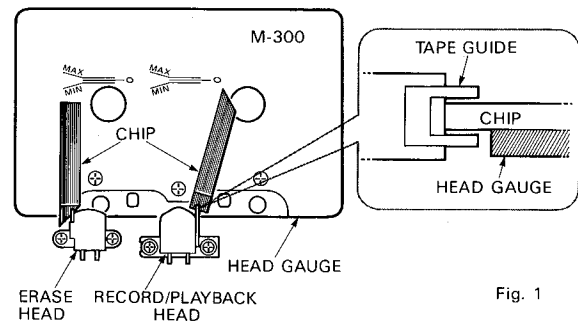

Fig. 1

● Head position

- Set the M-300 head gauge.
- Set the unit in the playback mode and place the adjustment chip on the head gauge as shown in the Fig. 2.
- With both record/playback head and erase head, the adjustment chip should be between MIN and MAX of the M-300 head gauge.

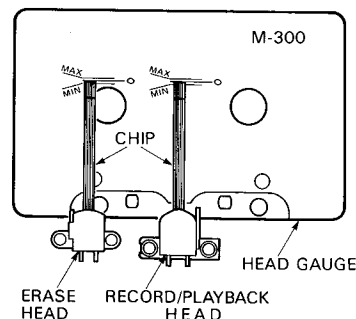

Fig. 2

■ ELECTRICAL ADJUSTMENT AND CONFIRMATION

1. Before adjustment

- Before electrical adjustment, make sure that confirmations of the cassette mechanism are all completed.
- After the power switch is pushed on, wait for 10 minutes before measuring to be sure of the most stable operation.
- Since head magnetization, dust accumulations, etc. are likely to introduce errors in the various characteristics, it is very important that the heads are properly demagnetized and cleaned before commencing any adjustment, particularly frequency response and head azimuth adjustment.

2. Instruments required

- Low frequency oscillator
- AC VTVM or dual channel AC VTVM
- Oscilloscope
- Wow/flutter meter
- Frequency counter

3. Test tapes

- Azimuth adjustment MTT-114
- Tape speed adjustment MTT-111 or MTT-111D
- Playback output level adjustment MTT-150 or TCC-130
- Playback frequency characteristic confirmation TCC-288H or TCC-162C, TCC-262C
- Reference tapes
 - LN SCC-502
 - CrO₂ SCC-504 and AC-512
 - METAL SCC-565

Note:

C-90 differs with C-60 in the thickness and bias is of unequal, so adjust with the tape whose bias in of specified value.

4. General conditions (unless otherwise noted)

Controls and Switches	Settings
Dolby NR	Off
Input Level	Maximum
MPX Filter	Off
Bias Fine Trim	Center
Input Balance	Center

Azimuth Adjustment

When the maximum level point of R channel does not equal that L channel, connect the oscilloscope as shown in Fig. 3 and proceed with azimuth adjustment so that L and R channels are in phase.

- Connect L channel tape out to "X (or V)" and R channel to "Y (or H)". Observe the lissajous waveform.
- Set L and R channels to monaural. Adjust vertical and horizontal gain so that the waveform becomes 45 degree.
- Adjust azimuth so that the measurement of "a" becomes maximum and the measurement of "b" becomes minimum against the 45 degree line.

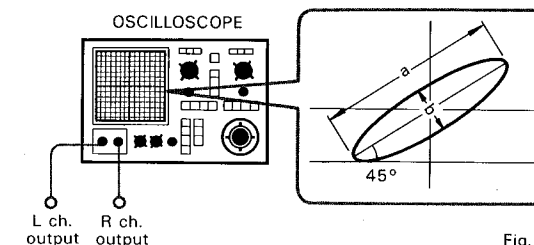
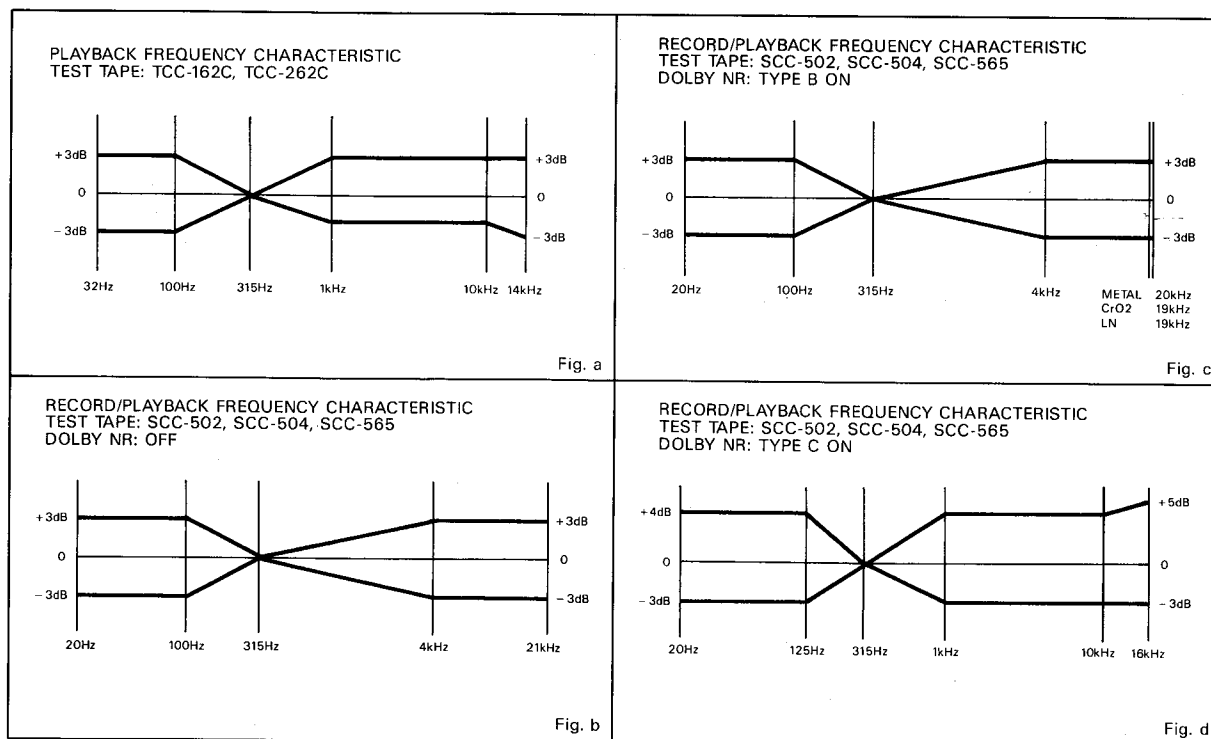

Fig. 3



ALIGNMENT PROCEDURES (REFER TO PAGES 11,12 AND 13)

■ CASSETTE MECHANISM CONFIRMATION

Make sure to confirm conditions of the cassette mechanism as follows before adjustment.

1. Confirmation of erroneous erase preventive function

- The switch should turn ON when a tape with erroneous erase preventive pawl is inserted. (Use a tape which is 0.2mm smaller than the minimum size of 62.9mm or a MAZ-0184-C gauge one.)
- When the switch arm is moved back gradually from the ON position, the switch should turn OFF.

2. Confirmation of cassette pack detection function

- The switch should turn ON when a tape is inserted. (Use a tape whose minimum size is 63.5mm or a MAZ-0184-C gauge one.)
- When the switch arm is moved back gradually from the ON position, the switch should turn OFF.

3. Confirmation of eject function

- The cassette compartment opens smoothly and no abnormal noise should be heard while opening and closing.
- The eject lock arm opens smoothly without contacting the chassis and damper.
- The eject button can not be pressed during playback.

4. Confirmation of playback, fast forward and rewind functions

- The torque used in each of the playback, fast forward and rewind modes should be within specification.
Playback 35gr. cm ~ 70gr. cm
Fast Forward 70gr. cm ~ 150gr. cm
Rewind 70gr. cm ~ 150gr. cm
- No abnormal noise should be heard during operation in any mode. The solenoid switching sound should not be considered as a noise.

5. Confirmation of positions of record/playback head and erase head

● Head height

- Set the M-300 head gauge.
- Set the unit in the playback mode and place the adjustment chip on the head gauge as shown in the Fig. 1.
- The adjustment chip should not contact the tape guide of both record/playback head and erase head.

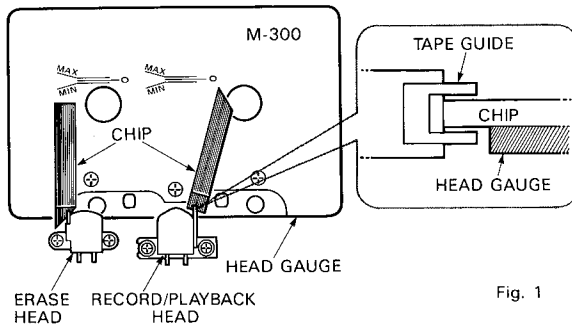

Fig. 1

● Head position

- Set the M-300 head gauge.
- Set the unit in the playback mode and place the adjustment chip on the head gauge as shown in the Fig. 2.
- With both record/playback head and erase head, the adjustment chip should be between MIN and MAX of the M-300 head gauge.

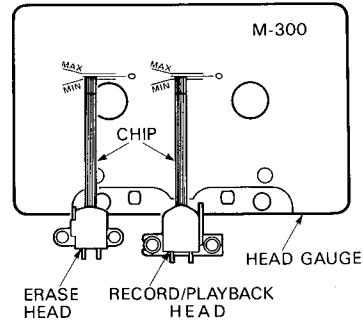

Fig. 2

ELECTRICAL ADJUSTMENT AND CONFIRMATION

1. Before adjustment

- Before electrical adjustment, make sure that confirmations of the cassette mechanism are all completed.
- After the power switch is pushed on, wait for 10 minutes before measuring to be sure of the most stable operation.
- Since head magnetization, dust accumulations, etc. are likely to introduce errors in the various characteristics, it is very important that the heads are properly demagnetized and cleaned before commencing any adjustment, particularly frequency response and head azimuth adjustment.

2. Instruments required

- Low frequency oscillator
- AC VTVM or dual channel AC VTVM
- Oscilloscope
- Wow/flutter meter
- Frequency counter

3. Test tapes

- Azimuth adjustment MTT-114
- Tape speed adjustment MTT-111 or MTT-111D
- Playback output level adjustment
..... MTT-150 or TCC-130
- Playback frequency characteristic confirmation
..... TCC-288H or TCC-162C, TCC-262C
- Reference tapes
LN SCC-502
CrO₂ SCC-504 and AC-512
METAL SCC-565

Note:

C-90 differs with C-60 in the thickness and bias is of unequal, so adjust with the tape whose bias is of specified value.

4. General conditions (unless otherwise noted)

Controls and Switches	Settings
Dolby NR	Off
Input Level	Maximum
MPX Filter	Off
Bias Fine Trim	Center
Input Balance	Center

Azimuth Adjustment

When the maximum level point of R channel does not equal that L channel, connect the oscilloscope as shown in Fig. 3 and proceed with azimuth adjustment so that L and R channels are in phase.

- Connect L channel tape out to "X (or V)" and R channel to "Y (or H)". Observe the lissajous waveform.
- Set L and R channels to monaural. Adjust vertical and horizontal gain so that the waveform becomes 45 degree.
- Adjust azimuth so that the measurement of "a" becomes maximum and the measurement of "b" becomes minimum against the 45 degree line.

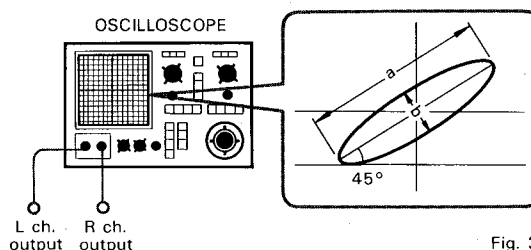
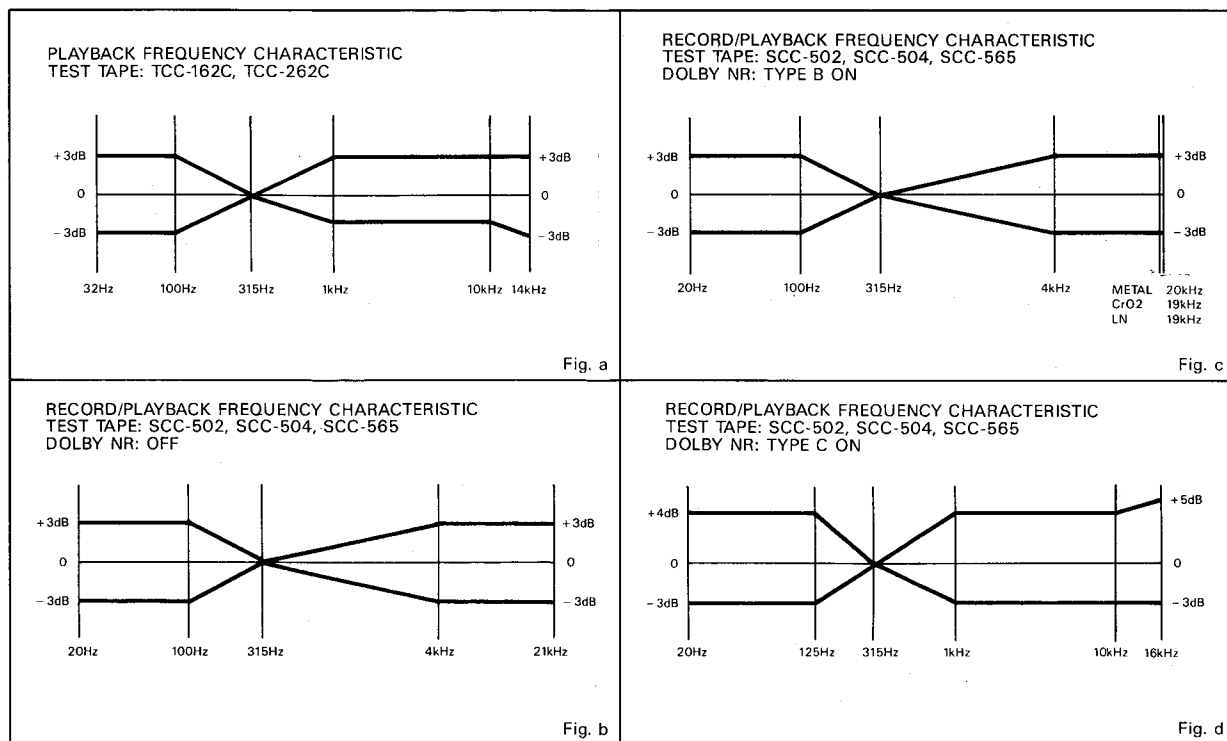

Fig. 3



Step	Alignment	Instrument Require	Input Signal	Mode	Test Point	Adjustment	For
1	Azimuth	VTVM Oscilloscope Test tape (MTT-114)		PB	TP1 TP2	Azimuth screw	Maximum output Refer to "Azimuth Adjustment" on page 9.
2	Tape speed	Frequency counter Test tape (MTT-111 or MTT-111D)		PB	TP1 TP2	VR (built in motor)	3000Hz \pm 10Hz Adjust at the center of test tape.
3	Playback output level	VTVM Test tape (MTT-150 or TCC-130)		PB	TP1 TP2	VR101 VR102	580mV
4	Playback frequency characteristic confirmation	VTVM Test tape (TCC-288H or TCC-162C and TCC-262C)		PB	OUTPUT jack		Confirm that the frequency response is within the range in Fig. a.
5	Bias trap	VTVM		REC-PAUSE	TP253 TP254	L203 L204	Minimum output
6	Bias level (pre-adjustment)	VTVM		REC-PAUSE	TP101, TP103 TP102, TP104	VR251 VR252	100mV Tape selector is metal position.
					TP102, TP104	VR254	52mV Tape selector is CrO ₂ position.
					TP102, TP104	VR253	32mV Tape selector is LN position.
7	Bias frequency	Frequency counter		REC-PAUSE	TP251 TP252		105kHz \pm 5kHz Tape selector is metal position.
8	Record level (pre-adjustment)	VTVM Blank tape (SCC-504 or AC-512)	Apply 400Hz signal to INPUT jack. Set INPUT LEVEL knob so that TP1 and TP2 voltage is 580mV in REC-PAUSE mode.	REC/PB	TP1 TP2	VR201 VR202	580mV Tape selector is CrO ₂ position.
9	Peaking coil (pre-adjustment)	VTVM Blank tape (SCC-565)	Apply 400Hz signal to INPUT jack. Set INPUT LEVEL knob so that TP101 and TP102 voltage is 580mV - 25dB in REC mode.	REC-PAUSE	TP101 TP102	L201 L202	So that output becomes maximum at 20kHz input. Short the TP251 and TP252. Tape selector is metal position.
10	Record/playback equalizer frequency characteristic (pre-adjustment)	VTVM Blank tape (SCC-565)	Apply 400Hz signal to INPUT jack. Set INPUT LEVEL knob so that TP1 and TP2 voltage is 580mV - 25dB in REC-PAUSE mode. Then adjust with a 20Hz to 30kHz sweep signal.	REC/PB	OUTPUT jack	VR253 VR254	So that the record/playback frequency response is flat (at least within the range in Fig. b). Tape selector is metal position.
11	Record/playback equalizer frequency characteristic	VTVM Blank tapes (metal SCC-565) (CrO ₂ SCC-504) (LN SCC-502)	Apply 400Hz signal to INPUT jack. Set INPUT LEVEL knob so that TP1 and TP2 voltage is 580mV - 25dB in REC-PAUSE mode. Then adjust with a 20Hz to 30kHz sweep signal.	REC/PB	OUTPUT jack	VR251, L202	So that the record/playback frequency response is flat (at least within the range in Fig. b). Tape selector is CrO ₂ position.
						VR253, L201	
						VR252	So that the record/playback frequency response is flat (at least within the range in Fig. b). Tape selector is LN position.
						check	Tape selector is metal position.
VR253	Tape selector is LN position. So that the record/playback frequency response of L ch. at metal position and that of L ch. at LN position are balanced.						
12	Record level	VTVM Blank tape (SCC-504)	Apply 400Hz signal to INPUT jack. Set INPUT LEVEL knob so that TP1 and TP2 voltage is 580mV in REC-PAUSE mode.	REC/PB	TP1 TP2	VR201 VR202	580mV Tape selector is CrO ₂ position.
13	Record level	VTVM Blank tapes (metal SCC-565) (LN SCC-502)	Apply 400Hz signal to INPUT jack. Set INPUT LEVEL knob so that TP1 and TP2 voltage is 580mV in REC-PAUSE mode.	REC/PB	TP1 TP2		580mV \pm 1dB This confirmation should be done at each tape selector position.
14	Record/playback equalizer frequency characteristic confirmation	VTVM Blank tapes (metal SCC-565) (CrO ₂ SCC-504) (LN SCC-502)	Apply 400Hz signal to INPUT jack. Set INPUT LEVEL knob so that TP1 and TP2 voltage is 580mV - 25dB in REC-PAUSE mode. Then adjust with a 20Hz to 30kHz sweep signal.	REC/PB	OUTPUT jack		Confirm that the record/playback frequency response is within the range in Fig. c and Fig. d. If it is not within the specification, redo the adjustment and confirmation in steps 10, 11 and 12. This confirmation should be done at each tape selector position under each of the following conditions, Dolby B NR on and Dolby C NR on.
15	Meter level	VTVM	Apply 400Hz signal to INPUT jack. Set INPUT LEVEL knob so that TP1 and TP2 voltage is 580mV - 0.5dB in REC-PAUSE mode.	REC-PAUSE	PEAK LEVEL METER	VR401 VR402	Adjust to the point where the 0 dB of the peak level meter lights.
16	MPX filter characteristic confirmation	VTVM	Apply 19kHz and 15kHz signal to INPUT jack. Set INPUT LEVEL knob so that TP1 and TP2 voltage is 580mV in REC-PAUSE mode.	REC-PAUSE	OUTPUT jack		Confirm that attenuation of 15kHz and 19kHz is within the specification when MPX filter on.
17	Anti-skwing level confirmation	VTVM	Apply 400Hz signal to INPUT jack. Set INPUT LEVEL knob so that TP1 and TP2 voltage is 580mV - 25dB in REC-PAUSE mode.	REC-PAUSE	TP201 TP202		Confirm that atenuation of 20kHz \pm Hz is maximum. Dolby C NR is on.

Step	Alignment	Instrument Require	Input Signal	
1	Azimuth	VTVM Oscilloscope Test tape (MTT-114)		
2	Tape speed	Frequency counter Test tape (MTT-111 or MTT-111D)		
3	Playback output level	VTVM Test tape (MTT-150 or TCC-130)		
4	Playback frequency characteristic confirmation	VTVM Test tape (TCC-288H or TCC-162C and TCC-262C)		
5	Bias trap	VTVM		
6	Bias level (pre-adjustment)	VTVM		
				1
				2
3				
7	Bias frequency	Frequency counter		
8	Record level (pre-adjustment)	VTVM Blank tape (SCC-504 or AC-512)	Apply 400Hz signal to INPUT jack. Set INPUT LEV and TP2 voltage is 580mV in REC-PAUSE mode.	
9	Peaking coil (pre-adjustment)	VTVM Blank tape (SCC-565)	Apply 400Hz signal to INPUT jack. Set INPUT LEV TP101 and TP102 voltage is 580mV - 25dB in RE	
10	Record/playback equalizer frequency characteristic (pre-adjustment)	VTVM Blank tape (SCC-565)	Apply 400Hz sigal to INPUT jack. Set INPUT LEV and TP2 voltage is 580mV - 25dB in REC-PAUSE. Then adjust with a 20Hz to 30kHz sweep signal.	
11	Record/playback equalizer frequency characteristic	VTVM Blank tapes (metal SCC-565) (CrO ₂ SCC-504) (LN SCC-502)	Apply 400Hz signal to INPUT jack. Set INPUT LEV and TP2 voltage is 580mV - 25dB in REC-PAUSE. Then adjust with a 20Hz to 30kHz sweep signal.	
				1
				2
				3
4				
12	Record level	VTVM Blank tape (SCC-504)	Apply 400Hz signal to INPUT jack. Set INPUT LEV and TP2 voltage is 580mV in REC-PAUSE mode.	
13	Record level	VTVM Blank tapes (metal SCC-565) (LN SCC-502)	Apply 400Hz signal to INPUT jack. Set INPUT LEV and TP2 voltage is 580mV in REC-PAUSE mode.	
14	Record/playback equalizer frequency characteristic confirmation	VTVM Blank tapes (metal SCC-565) (CrO ₂ SCC-504) (LN SCC-502)	Apply 400Hz signal to INPUT jack. Set INPUT LEV and TP2 voltage is 580mV - 25dB in REC-PAUSE. Then adjust with a 20Hz to 30kHz sweep signal.	
15	Meter level	VTVM	Apply 400Hz signal to INPUT jack. Set INPUT LEV and TP2 voltage is 580mV - 0.5dB in REC-PAUS	
16	MPX filter characteristic confirmation	VTVM	Apply 19kHz and 15kHz signal to INPUT jack. Se so that TP1 and TP2 voltage is 580mV in REC-PA	
17	Anti-skwing level confirmation	VTVM	Apply 400Hz signal to INPUT jack. Set INPUT LEV and TP2 voltage is 580mV - 25dB in REC-PAUSE	

		Mode	Test Point	Adjustment	For
		PB	TP1 TP2	Azimuth screw	Maximum output Refer to "Azimuth Adjustment" on page 9.
		PB	TP1 TP2	VR (built in motor)	3000Hz \pm 10Hz Adjust at the center of test tape.
		PB	TP1 TP2	VR101 VR102	580mV
		PB	OUTPUT jack		Confirm that the frequency response is within the range in Fig. a.
		REC-PAUSE	TP253 TP254	L203 L204	Minimum output
		REC-PAUSE	TP101, TP103 TP102, TP104	VR251 VR252	100mV Tape selector is metal position.
			TP102, TP104	VR254	52mV Tape selector is CrO ₂ position.
			TP102, TP104	VR253	32mV Tape selector is LN position.
		REC-PAUSE	TP251 TP252		105kHz \pm 5kHz Tape selector is metal position.
LEVEL knob so that TP1 level.		REC/PB	TP1 TP2	VR201 VR202	580mV Tape selector is CrO ₂ position.
LEVEL knob so that REC mode.		REC-PAUSE	TP101 TP102	L201 L202	So that output becomes maximum at 20kHz input. Short the TP251 and TP252. Tape selector is metal position.
LEVEL knob so that TP1 USE mode. nal.		REC/PB	OUTPUT jack	VR253 VR254	So that the record/playback frequency response is flat (at least within the range in Fig. b). Tape selector is metal position.
LEVEL knob so that TP1 USE mode. nal.		REC/PB	OUTPUT jack	VR251, L202	So that the record/playback frequency response is flat (at least within the range in Fig. b). Tape selector is CrO ₂ position.
				VR253, L201	
				VR252	So that the record/playback frequency response is flat (at least within the range in Fig. b). Tape selector is LN position.
				check	Tape selector is metal position.
			VR253	Tape selector is LN position. So that the record/playback frequency response of L ch. at metal position and that of L ch. at LN position are balanced.	
LEVEL knob so that TP1 level.		REC/PB	TP1 TP2	VR201 VR202	580mV Tape selector is CrO ₂ position.
LEVEL knob so that TP1 level.		REC/PB	TP1 TP2		580mV \pm 1dB This confirmation should be done at each tape selector position.
LEVEL knob so that TP1 USE mode. nal.		REC/PB	OUTPUT jack		Confirm that the record/playback frequency response is within the range in Fig. c and Fig. d. If it is not within the specification, redo the adjustment and confirmation in steps 10, 11 and 12. This confirmation should be done at each tape selector position under each of the following conditions, Dolby B NR on and Dolby C NR on.
LEVEL knob so that TP1 USE mode.		REC-PAUSE	PEAK LEVEL METER	VR401 VR402	Adjust to the point where the 0 dB of the peak level meter lights.
Set INPUT LEVEL knob REC-PAUSE mode.		REC-PAUSE	OUTPUT jack		Confirm that attenuation of 15kHz and 19kHz is within the specification when MPX filter on.
LEVEL knob so that TP1 USE mode.		REC-PAUSE	TP201 TP202		Confirm that attenuation of 20kHz \pm Hz is maximum. Dolby C NR is on.

SCHEMATIC DIAGRAM (1)

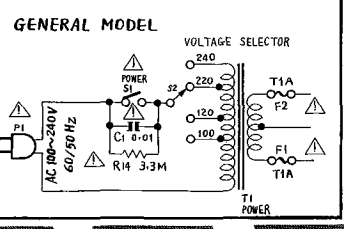
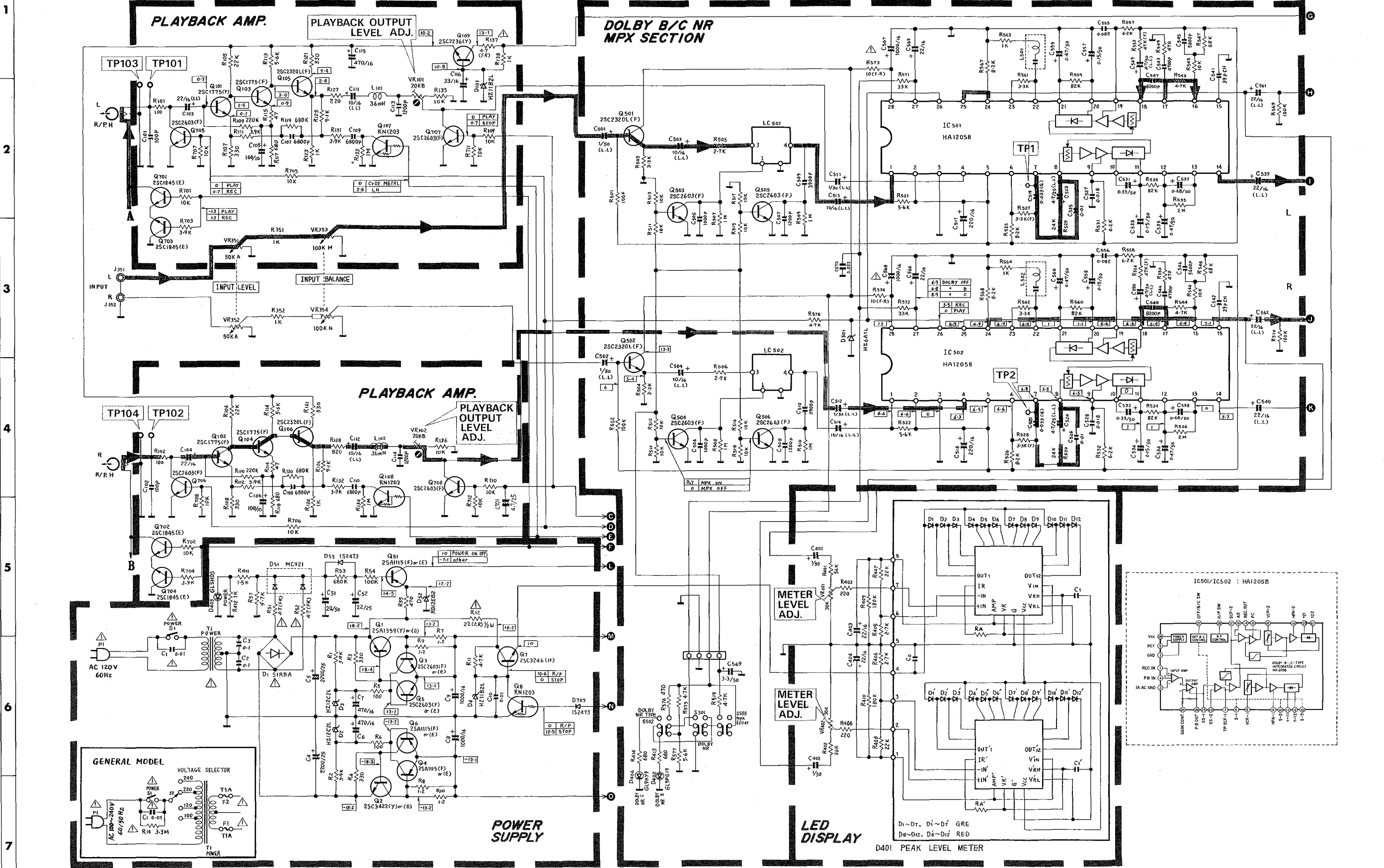

POWER SUPPLY

METER LEVEL ADJ.

METER LEVEL ADJ.

LED DISPLAY

D401 PEAK LEVEL METER

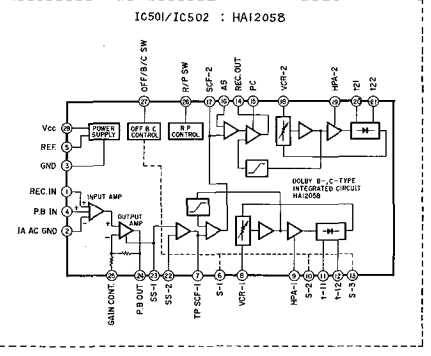

F G H I J

Y B/C NR SECTION

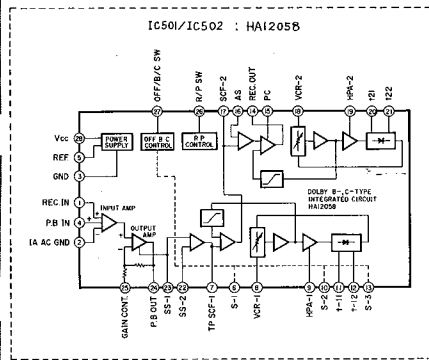
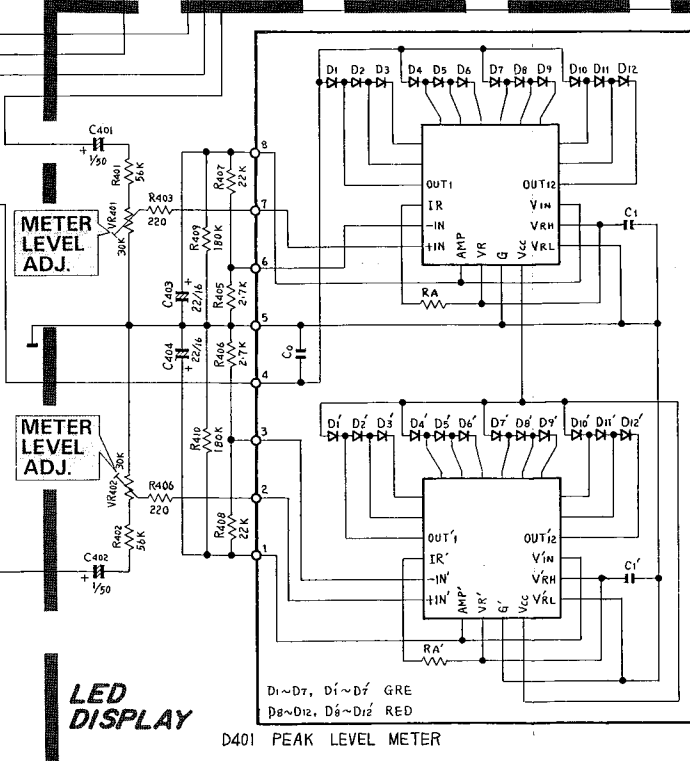
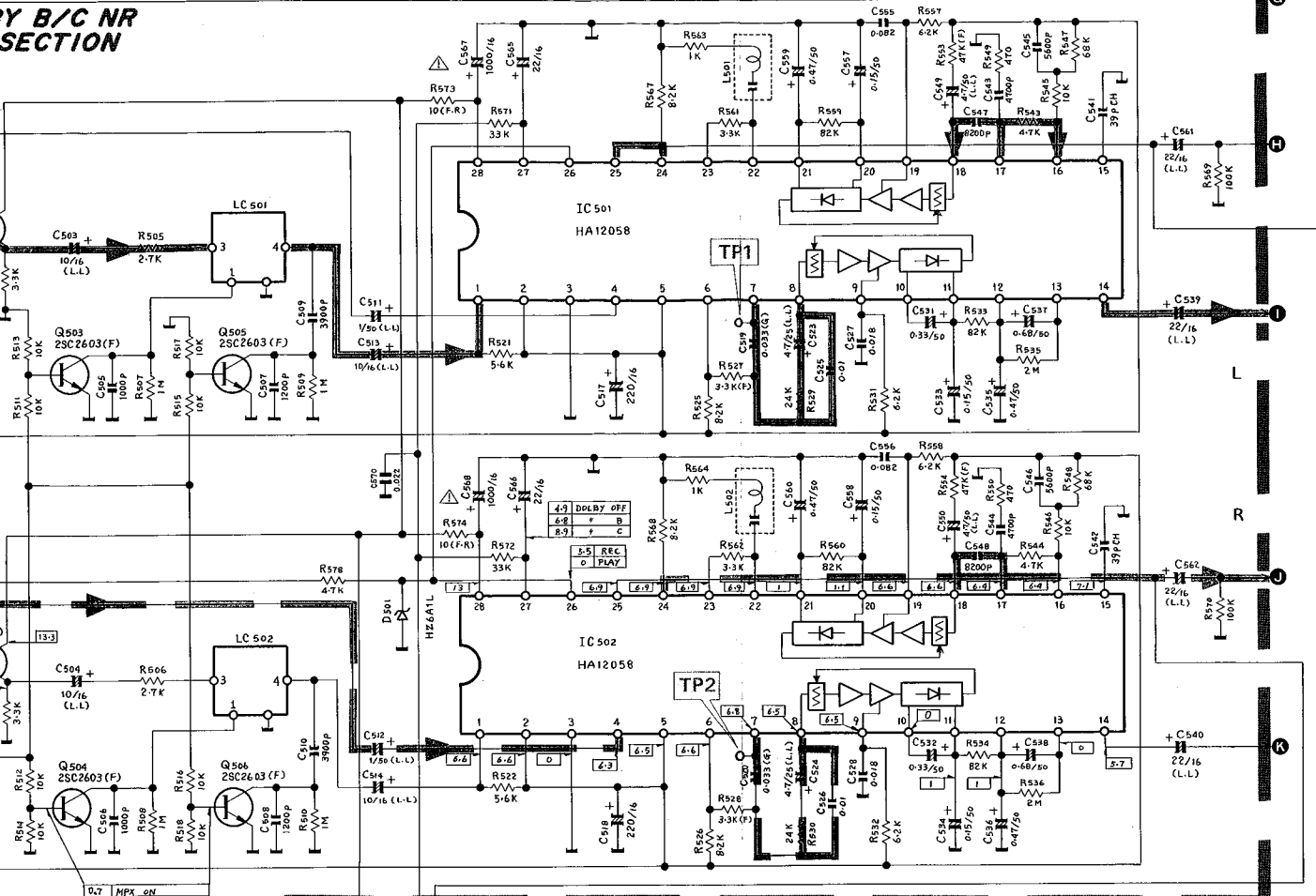

LED DISPLAY

D401 PEAK LEVEL METER

SCHEMATIC DIAGRAM (2)

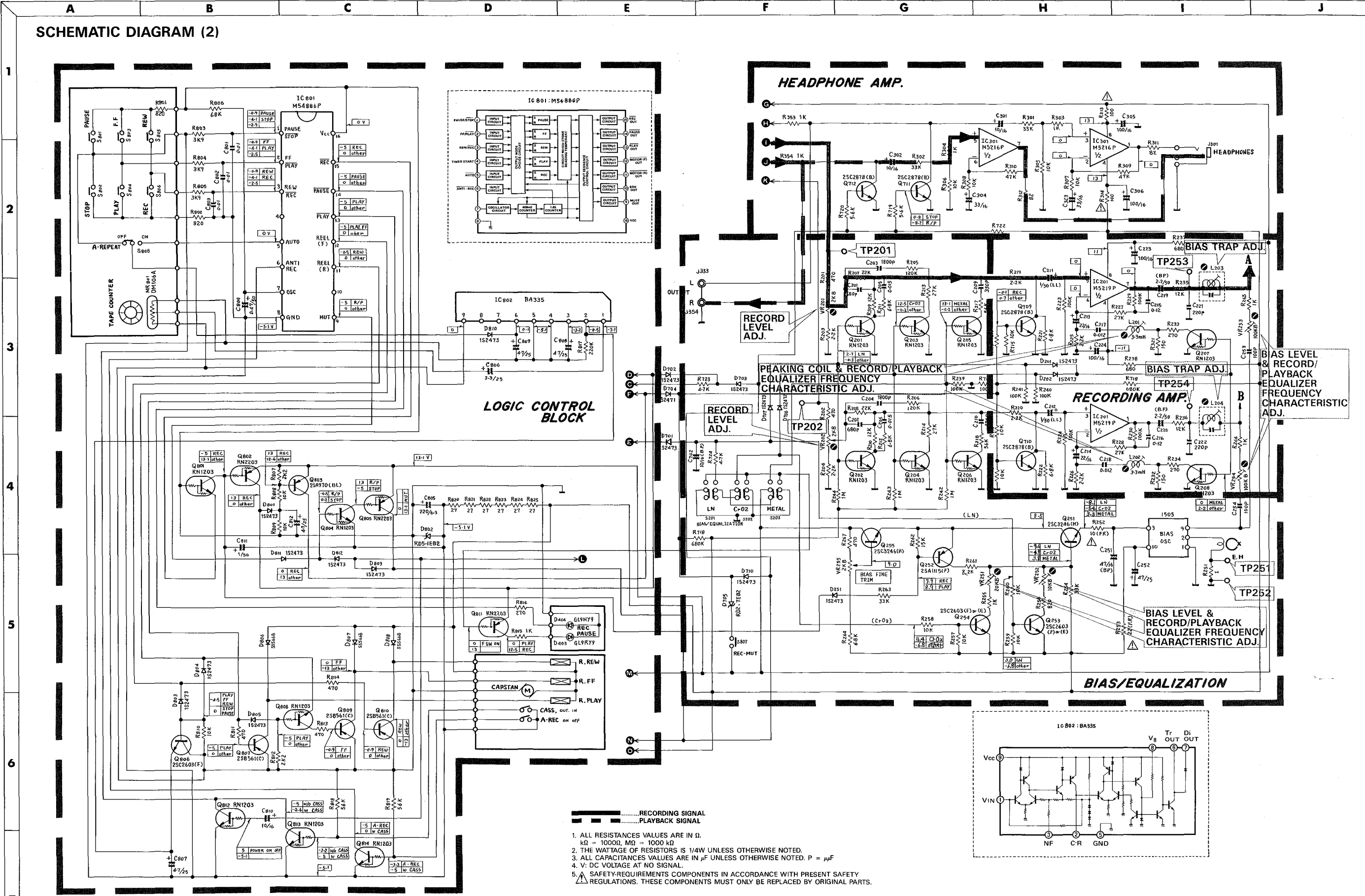

SCHMATIC DIAGRAM (2)

1
2
3
4
5
6
7

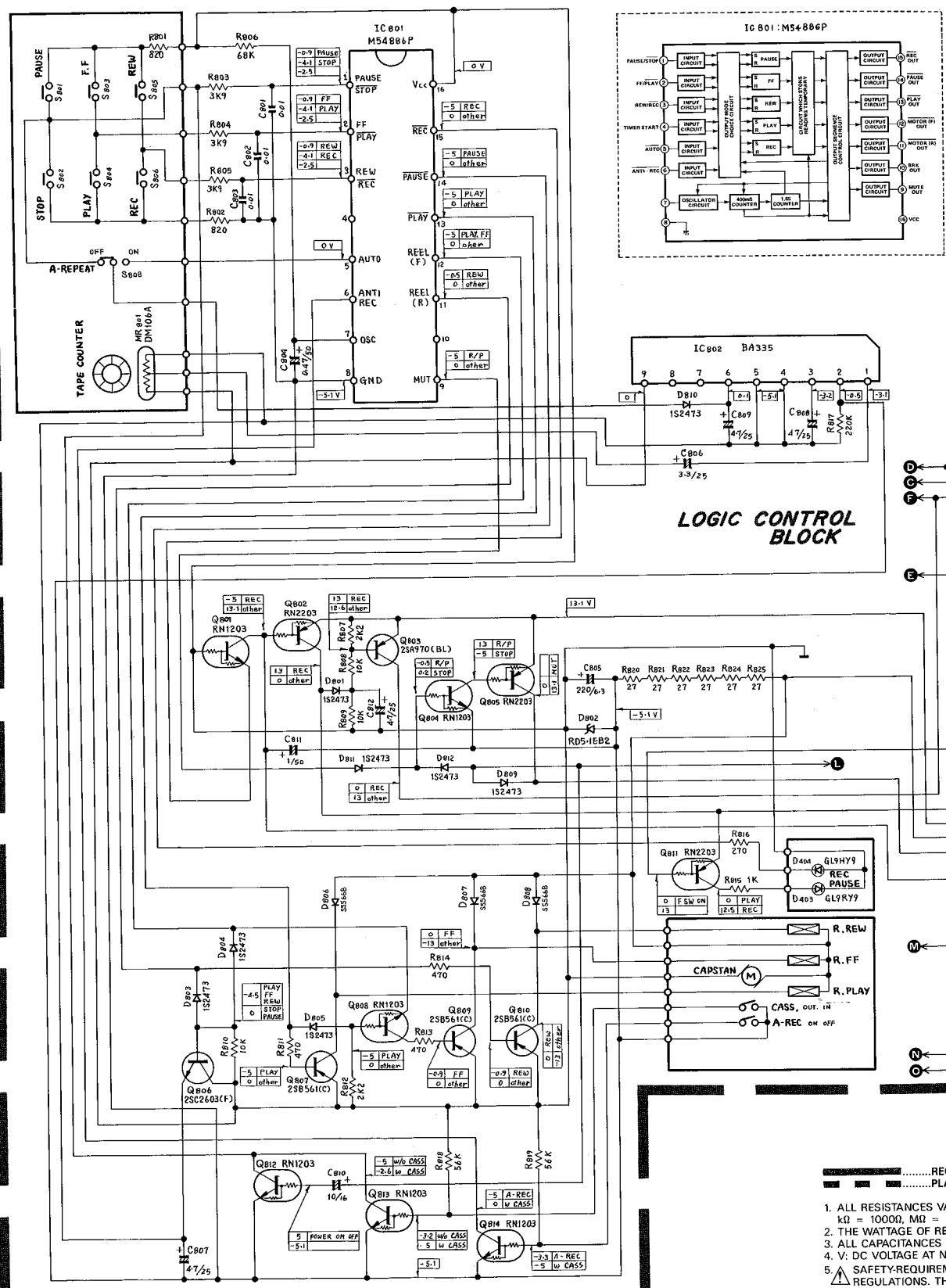

LOGIC CONTROL BLOCK

- 1. ALL RESISTANCES VALUE IN OHMS UNLESS SPECIFIED OTHERWISE.
- 2. THE WATTAGE OF RESISTORS IS 1/4 WATT UNLESS SPECIFIED OTHERWISE.
- 3. ALL CAPACITANCES VALUE IN PICO FARADS UNLESS SPECIFIED OTHERWISE.
- 4. V: DC VOLTAGE AT NO SIGNAL.
- 5. SAFETY REQUIREMENTS AS PER IEC REGULATIONS. THESE

HEADPHONE AMP.

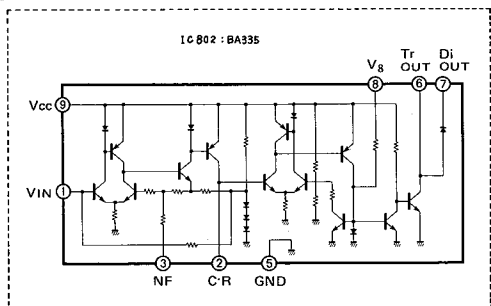
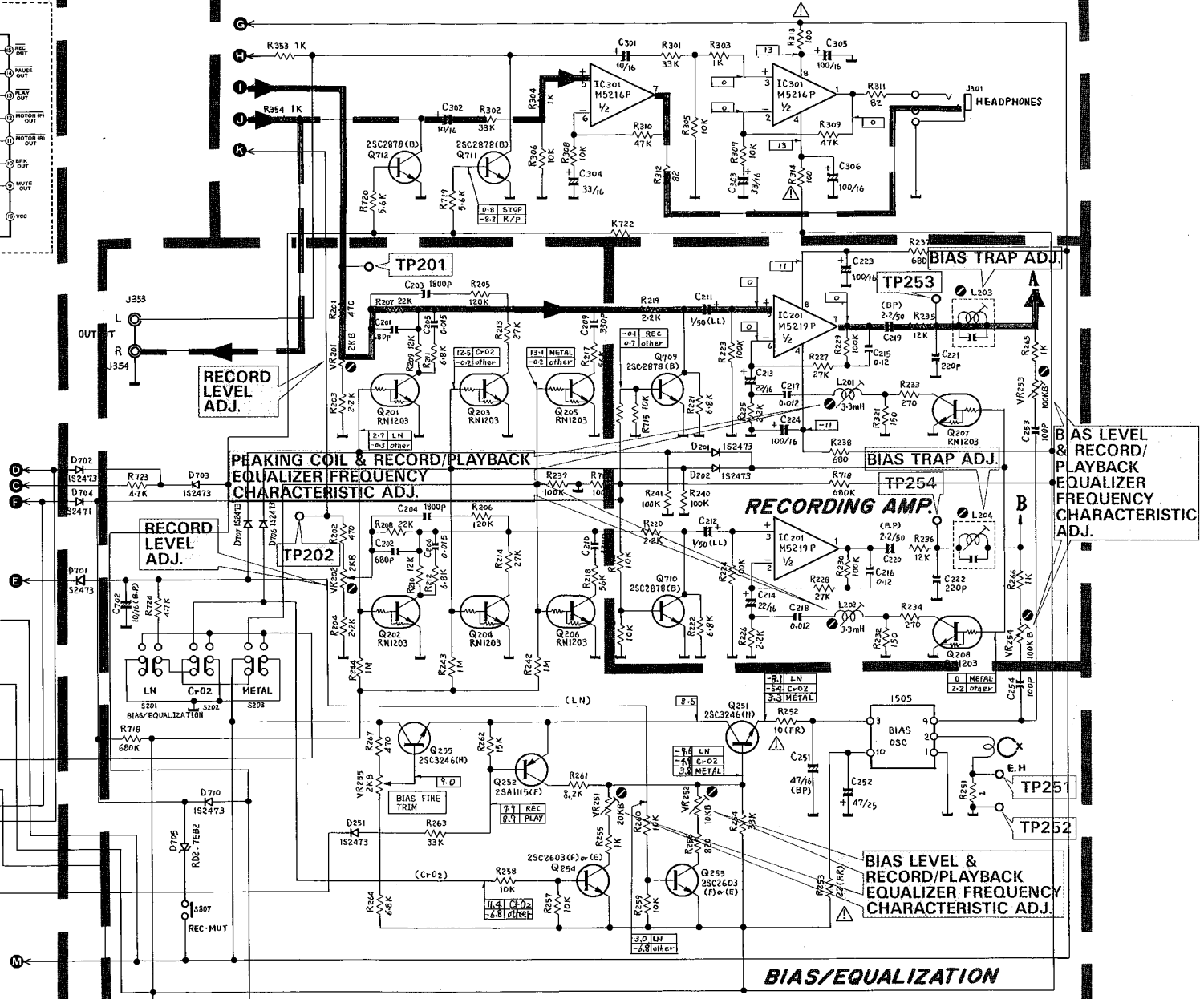

.....RECORDING SIGNAL
PLAYBACK SIGNAL

RESISTANCE VALUES ARE IN Ω .
 K, M Ω = 1000 k Ω .
 VALUE OF RESISTORS IS 1/4W UNLESS OTHERWISE NOTED.
 CAPACITANCE VALUES ARE IN μ F UNLESS OTHERWISE NOTED. P = μ pF
 VALUE AT NO SIGNAL.

REQUIREMENTS COMPONENTS IN ACCORDANCE WITH PRESENT SAFETY
 REGULATIONS. THESE COMPONENTS MUST ONLY BE REPLACED BY ORIGINAL PARTS.

P. C. BOARDS

PCB-1 Main P. C. Board

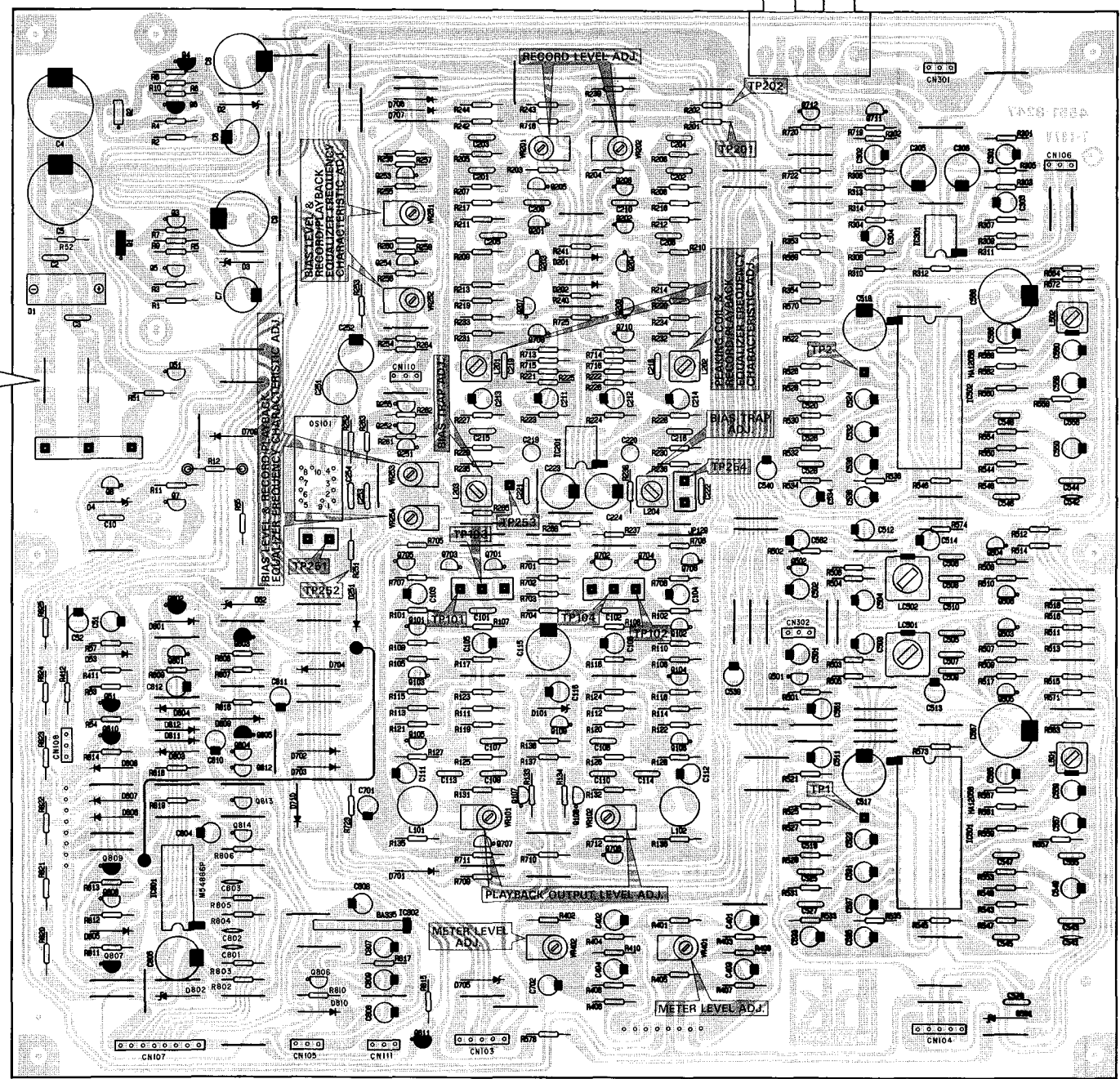

OUTPUT INPUT
J353 L L J351
J354 R R J352

PCB-2 Function Switch P. C. Board

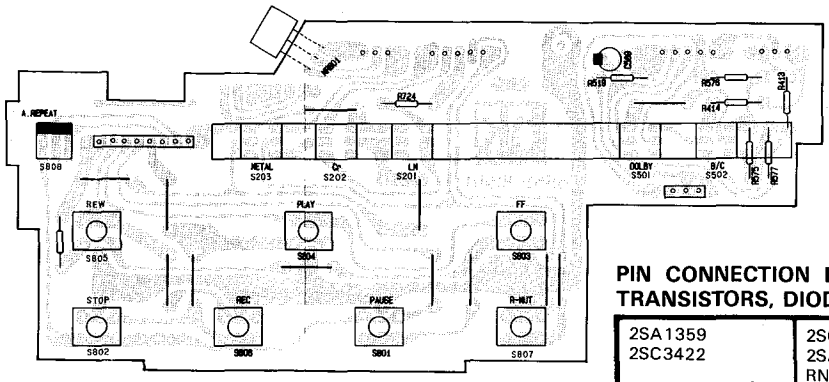

PCB-5 Power Switch P. C. Board

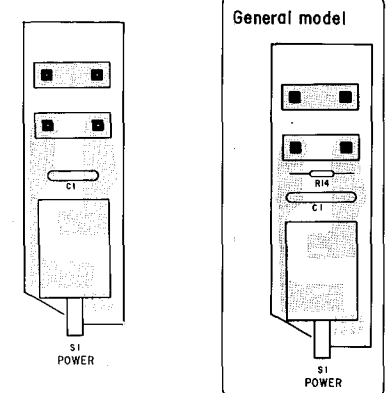

PCB-6 Dolby NR Ind. P. C. Board

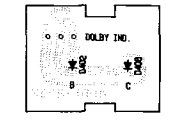

PCB-7 Rec/Pause Ind. P. C. Board

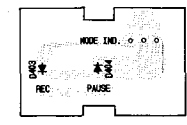

PCB-8 Power Ind. P. C. Board

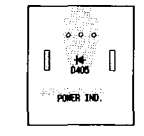

PCB-9 Headphones Jack P. C. Board

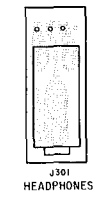

PIN CONNECTION DIAGRAM OF TRANSISTORS, DIODES AND ICs.

2SA1359 2SC3422	2SC2603 2SA1115 RN1203 RN2203
2SC3246 2SC1775 2SC2320L 2SC1845 2SC2878 2SB561	2SC2236 2SA970
S1RBA	HZ12C2L RD12EB2 1S2473 HZ11B2L HZ6A1L RD2.7 EB2 RD5.1 EB2 S5566B
GL9PG19 GL9HY9 GL9PR9	MC921
GL5HD5	
HA12058	M5219P M5216P
M54886P	BA335

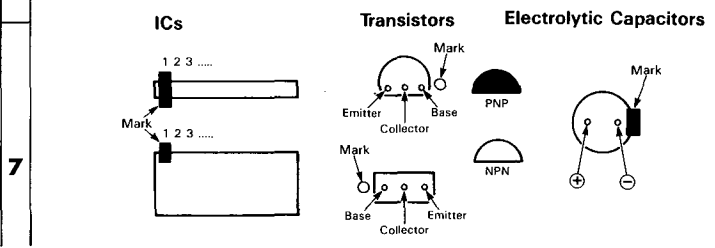
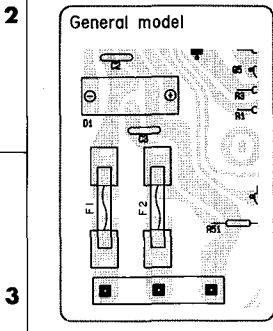

PCB-3 VR P. C. Board

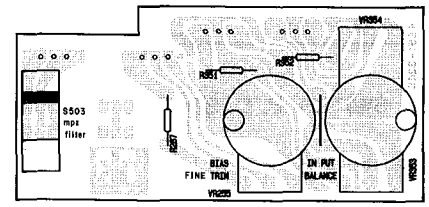

PCB-4 Input Level Control P. C. Board

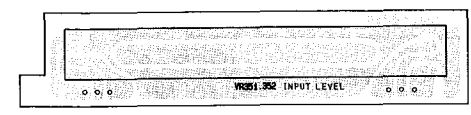

P. C. BOARDS

PCB-1 Main P. C. Board

OUTPUT INPUT
J353 L L J351
J354 R R J352

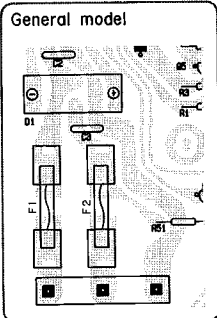
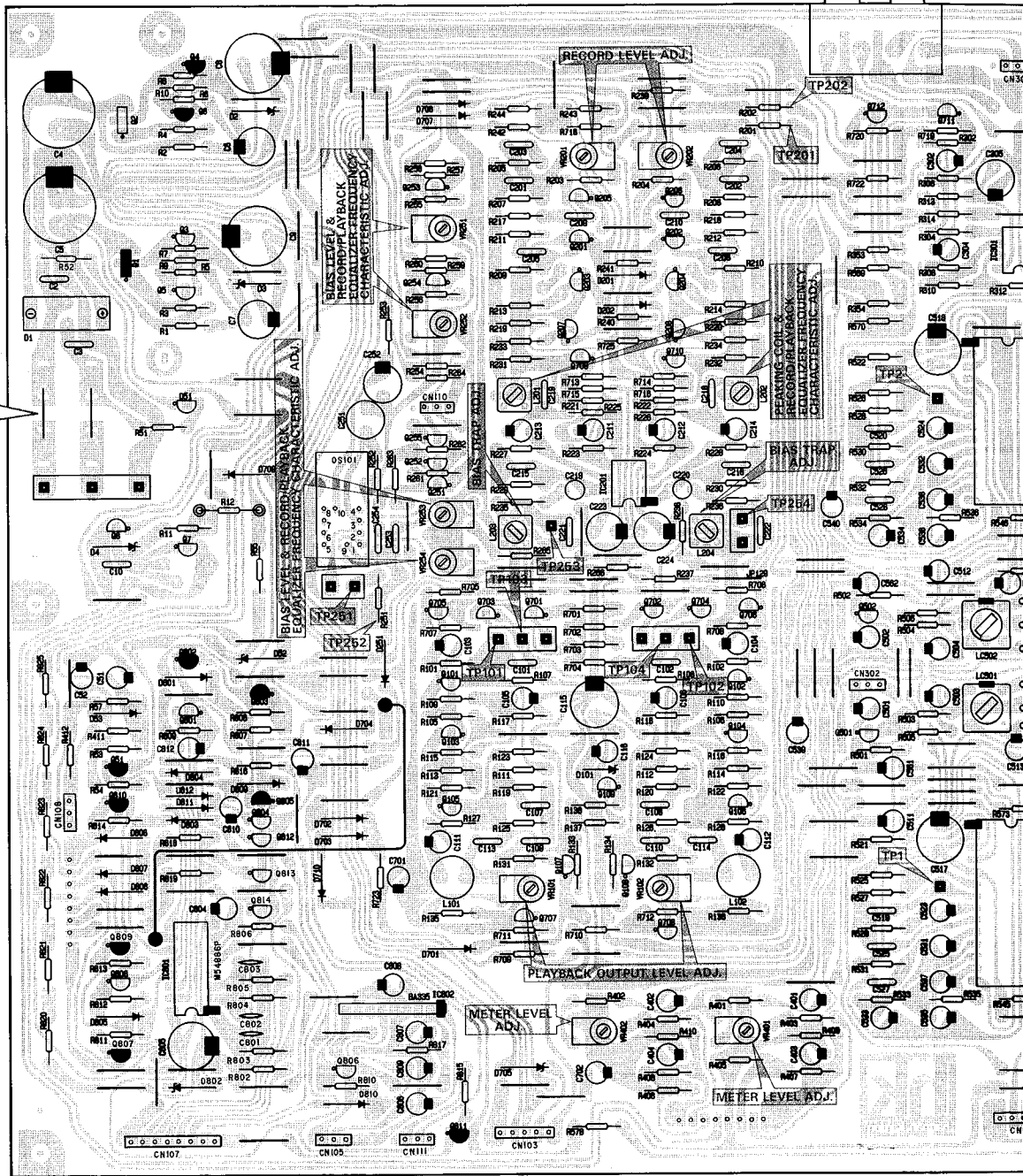

ICs

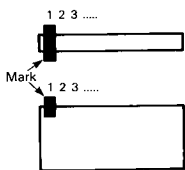

Transistors

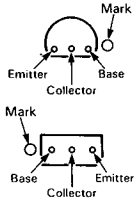

Electrolytic Capacitors

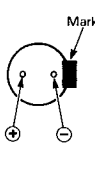

PCB-3 VR P. C. Board

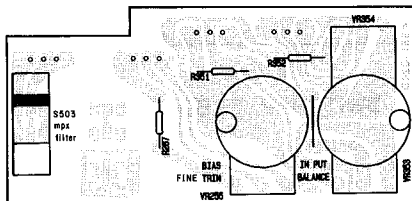

PCB-4 Input



1
2
3
4
5
6
7

WIRING DIAGRAM

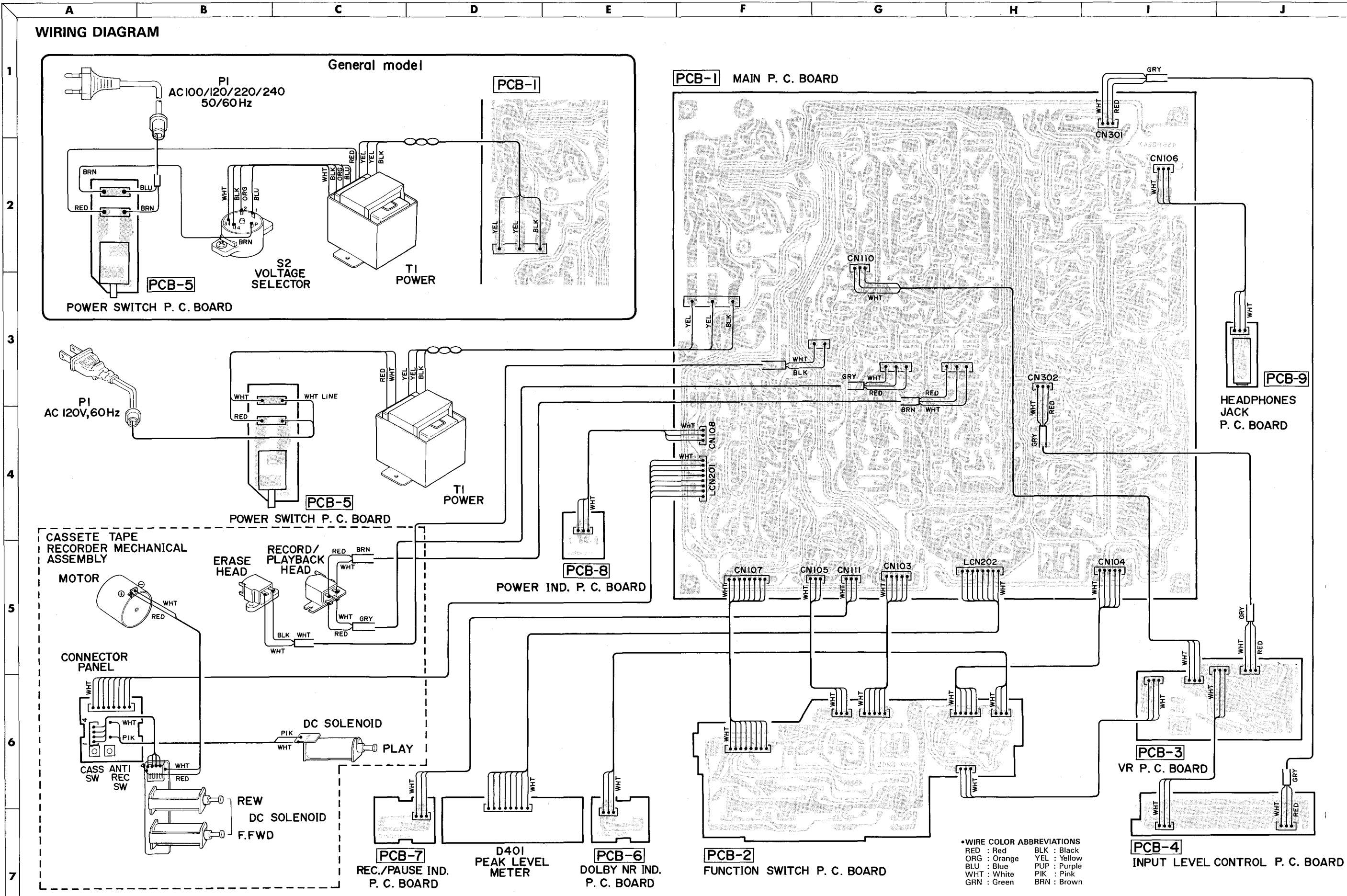

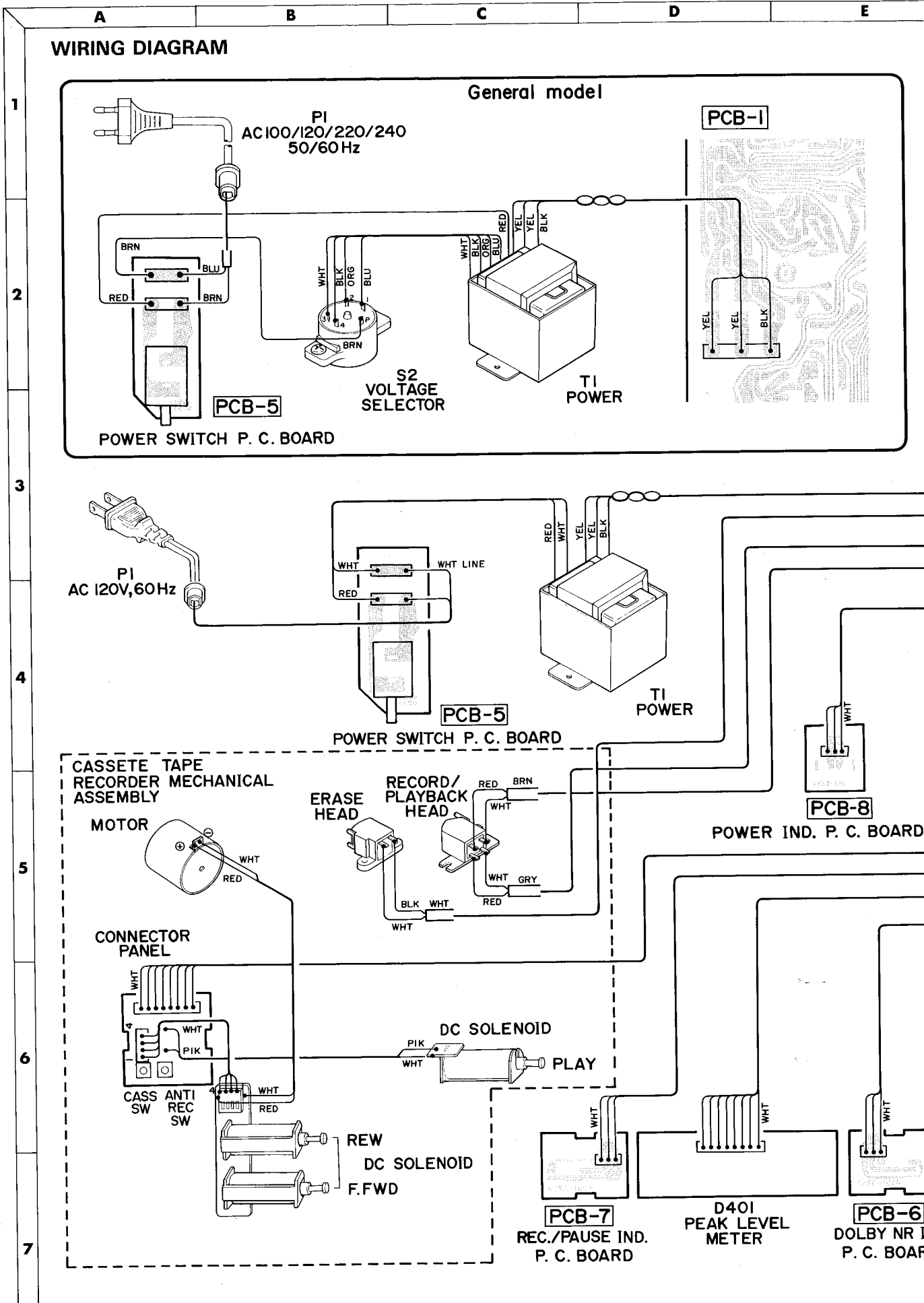

PCB-1 MAIN P. C. BOARD

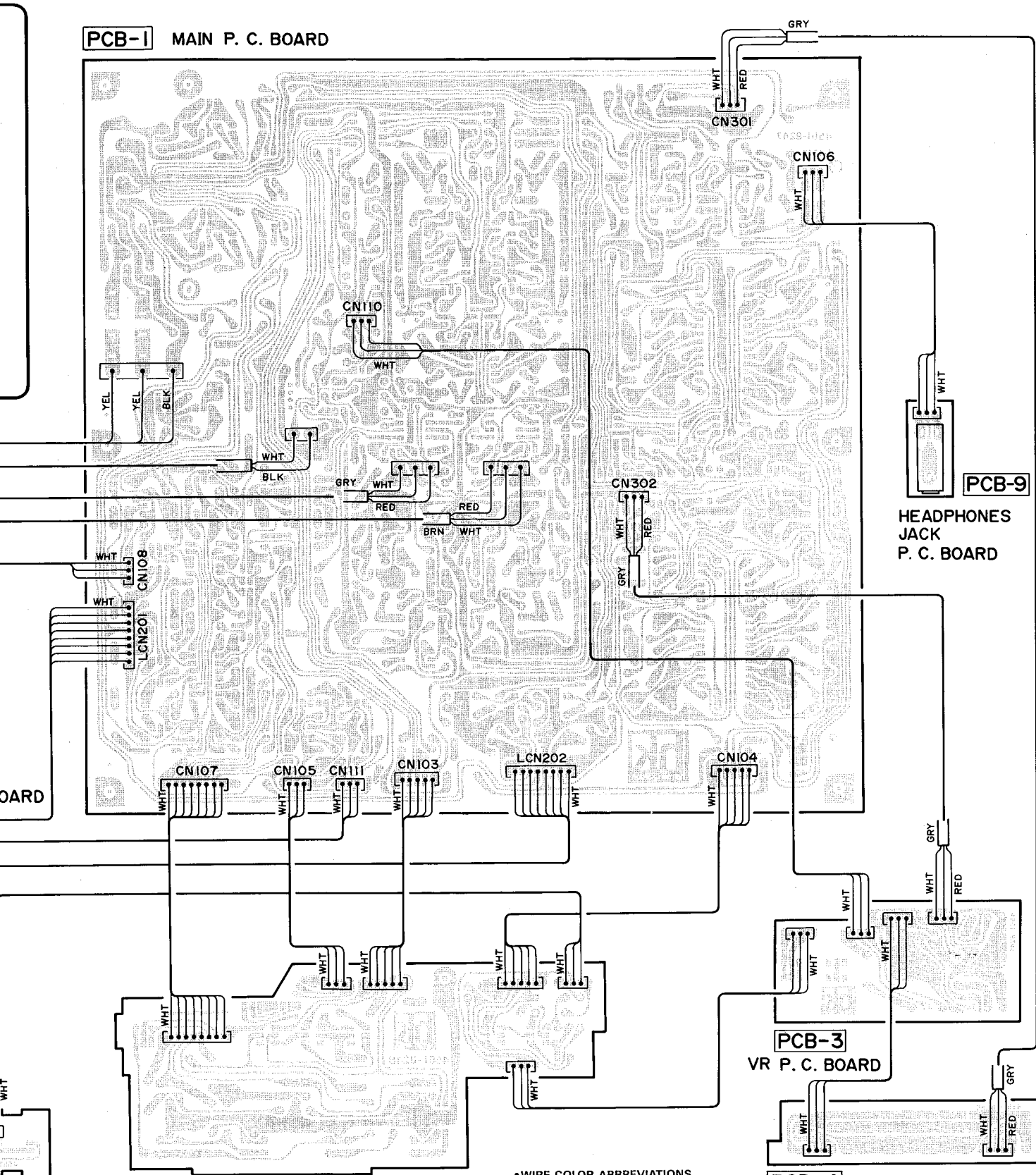

PCB-9

HEADPHONES JACK P. C. BOARD

PCB-3
VR P. C. BOARD

PCB-4
INPUT LEVEL CONTROL P. C. BOARD

B-6
NR IND. BOARD

PCB-2
FUNCTION SWITCH P. C. BOARD

- WIRE COLOR ABBREVIATIONS
- | | |
|--------------|--------------|
| RED : Red | BLK : Black |
| ORG : Orange | YEL : Yellow |
| BLU : Blue | PUP : Purple |
| WHT : White | PIK : Pink |
| GRN : Green | BRN : Brown |

ELECTRICAL PARTS LIST

Ref. No.	Part No.	Description
CHASSIS MISCELLANEOUS		
△ P1	4161-71151	Power Cord U A
△ P1	4161-7256	Power Cord EW
△ T1	5584-701376	Power Trans. U A
△ T1	5584-702392	Power Trans. EW
△ S2	4411-104736	Rotary Switch, Voltage Selector
△ F1	5732-10202	Fuse, T1A EW
△ F2	5732-10202	Fuse, T1A EW
D401	5623-LT1151 4161-71184	Peak Level Meter Connection Cord (Accessory)
PCB-1 MAIN P.C. BOARD		
RESISTORS		
△ R12	5102-2205114	22Ω, 1/2W, FR
△ R51	5102-4R74715	4.7Ω, 1/4W, FR
△ R52	5102-4R74715	4.7Ω, 1/4W, FR
△ R137	5102-4R74715	4.7Ω, 1/4W, FR
△ R252	5102-1004715	10Ω, 1/4W, FR
△ R253	5102-1004715	10Ω, 1/4W, FR
△ R313	5102-1014715	100Ω, 1/4W, FR
△ R314	5102-1014715	100Ω, 1/4W, FR
R527	5174-332381	3.3kΩ, 1/4W, MR
R528	5174-332381	3.3kΩ, 1/4W, MR
R553	5174-473381	47kΩ, 1/4W, MR
R554	5174-473381	47kΩ, 1/4W, MR
△ R573	5102-1004715	10Ω, 1/4W, FR
△ R574	5102-1004715	10Ω, 1/4W, FR
CONTROLS		
VR101	5101-20371920	20kΩB
VR102	5101-20371920	20kΩB
VR201	5101-20271920	2kΩB
VR202	5101-20271920	2kΩB
VR251	5101-20371920	20kΩB
VR252	5101-10371920	10kΩB
VR253	5101-10471920	100kΩB
VR254	5101-10471920	100kΩB
VR401	5101-30371920	30kΩ
VR402	5101-30371920	30kΩ
CAPACITORS		
C4	5345-228D041	2200μF/25V, EC
C5	5345-228D041	2200μF/25V, EC
C6	5345-477C041	470μF/16V, EC
C7	5345-477C041	470μF/16V, EC
C8	5345-108C041	1000μF/16V, EC
C9	5345-108C041	1000μF/16V, EC
C51	5345-226F041	22μF/50V, EC
C52	5345-226D041	22μF/25V, EC
C101	5353-101534	100pF/500V, MC
C102	5353-101534	100pF/500V, MC
C103	5345-226C0951	22μF/16V, EC
C104	5345-226C0951	22μF/16V, EC
C105	5345-107B041	100μF/10V, EC
C106	5345-107B041	100μF/10V, EC
C107	5359-6825851	6800pF/100V, PC
C108	5359-6825851	6800pF/100V, PC
C109	5359-6825851	6800pF/100V, PC
C110	5359-6825851	6800pF/100V, PC
C111	5345-106C0951	10μF/16V, EC
C112	5345-106C0951	10μF/16V, EC
C113	5359-1225851	1200pF/100V, PC
C114	5359-1225851	1200pF/100V, PC
C115	5345-477C041	470μF/16V, EC
C116	5345-336C041	33μF/16V, EC
C201	5359-6815851	680pF/100V, PC
C202	5359-6815851	680pF/100V, PC
C209	5359-3315851	330pF/100V, PC
C210	5359-3315851	330pF/100V, PC
C211	5345-105F0951	1μF/50V, EC
C212	5345-105F0951	1μF/50V, EC
C213	5345-226C0952	22μF/16V, EC
C214	5345-226C0952	22μF/16V, EC

Ref. No.	Part No.	Description
C219	5342-225F0951	2.2μF/50V, EC
C220	5342-225F0951	2.2μF/50V, EC
C223	5345-107C041	100μF/16V, EC
C224	5345-107C041	100μF/16V, EC
C251	5342-476C0951	47μF/16V, EC
C252	5345-476D041	47μF/25V, EC
C253	5353-101534	100pF/500V, MC
C254	5353-101534	100pF/500V, MC
C301	5345-106C041	10μF/16V, EC
C302	5345-106C041	10μF/16V, EC
C303	5345-336C041	33μF/16V, EC
C304	5345-336C041	33μF/16V, EC
C305	5345-107C041	100μF/16V, EC
C306	5345-107C041	100μF/16V, EC
C401	5345-105F041	1μF/50V, EC
C402	5345-105F041	1μF/50V, EC
C403	5345-226C041	22μF/16V, EC
C404	5345-226C041	22μF/16V, EC
C501	5345-105F0951	1μF/50V, EC
C502	5345-105F0951	1μF/50V, EC
C503	5345-106C0951	10μF/16V, EC
C504	5345-106C0951	10μF/16V, EC
C505	5359-1025851	1000pF/100V, PC
C506	5359-1025851	1000pF/100V, PC
C511	5345-105F0951	1μF/50V, EC
C512	5345-105F0951	1μF/50V, EC
C513	5345-106C0951	10μF/16V, EC
C514	5345-106C0951	10μF/16V, EC
C517	5345-227C041	220μF/16V, EC
C518	5345-227C041	220μF/16V, EC
C519	5359-333741	0.033μF/100V, PC
C520	5359-333741	0.033μF/100V, PC
C523	5345-475D0952	4.7μF/25V, EC
C524	5345-475D0952	4.7μF/25V, EC
C531	5345-334F0952	0.33μF/50V, EC
C532	5345-334F0952	0.33μF/50V, EC
C533	5345-154F0952	0.15μF/50V, EC
C534	5345-154F0952	0.15μF/50V, EC
C535	5345-474F0952	0.47μF/50V, EC
C536	5345-474F0952	0.47μF/50V, EC
C537	5345-684F0952	0.68μF/50V, EC
C538	5345-684F0952	0.68μF/50V, EC
C539	5345-226C0951	22μF/16V, EC
C540	5345-226C0951	22μF/16V, EC
C549	5345-475D0952	4.7μF/25V, EC
C550	5345-475D0952	4.7μF/25V, EC
C557	5345-154F0952	0.15μF/50V, EC
C558	5345-154F0952	0.15μF/50V, EC
C559	5345-474F0952	0.47μF/50V, EC
C560	5345-474F0952	0.47μF/50V, EC
C561	5345-226C0951	22μF/16V, EC
C562	5345-226C0951	22μF/16V, EC
C565	5345-226C041	22μF/16V, EC
C566	5345-226C041	22μF/16V, EC
C567	5345-108C041	1000μF/16V, EC
C568	5345-108C041	1000μF/16V, EC
C701	5345-475D041	4.7μF/25V, EC
C702	5342-106D0921	10μF/25V, EC
C804	5345-474F041	0.47μF/50V, EC
C805	5345-227B041	220μF/10V, EC
C806	5345-335D041	3.3μF/25V, EC
C807	5345-475D041	4.7μF/25V, EC
C808	5345-476C041	47μF/16V, EC
C809	5345-475D041	4.7μF/25V, EC
C810	5345-106C041	10μF/16V, EC
C811	5345-105F041	1μF/50V, EC
C812	5345-475D041	4.7μF/25V, EC
INTEGRATED CIRCUIT		
IC201	5652-M5219P	M5219P
IC301	5652-M5216P	M5219P
IC501	5652-HA 12058	HA 12058
IC502	5652-HA 12058	HA 12058
IC801	5654-M54886P	M54886P
IC802	5652-BA335	BA335

Ref. No.	Part No.	Description
	TRANSISTORS	
Q1	5611-1359(Y)	2SA1359(Y) or (O)
Q2	5613-3422(Y)	2SC3422(Y) or (O)
Q3	5613-2603(F)	2SC2603(F)
Q4	5611-1115(F)	2SA1115(F)
Q5	5613-2603(F)	2SC2603(F)
Q6	5611-1115(F)	2SA1115(F)
Q7	5613-3246(H)	2SC3246(H)
Q8	5613-RN1203	RN1203
Q51	5611-1115(F)	2SA1115(F)
Q101	5613-1775(F)	2SC1775(F)
Q102	5613-1775(F)	2SC1775(F)
Q103	5613-1775(F)	2SC1775(F)
Q104	5613-1775(F)	2SC1775(F)
Q105	5613-2320L(F)	2SC2320L(F)
Q106	5613-2320L(F)	2SC2320L(F)
Q107	5613-RN1203	RN1203
Q108	5613-RN1203	RN1203
Q109	5613-2236(Y)	2SC2236(Y)
Q201	5613-RN1203	RN1203
Q202	5613-RN1203	RN1203
Q203	5613-RN1203	RN1203
Q204	5613-RN1203	RN1203
Q205	5613-RN1203	RN1203
Q206	5613-RN1203	RN1203
Q207	5613-RN1203	RN1203
Q208	5613-RN1203	RN1203
Q251	5613-3246(H)	2SC3246(H)
Q252	5611-1115(F)	2SA1115(F) or (E)
Q253	5613-2603(F)	2SC2603(F) or (E)
Q254	5613-2603(F)	2SC2603(F) or (E)
Q255	5613-3246(H)	2SC3246(H)
Q501	5613-2320L(F)	2SC2320L(F)
Q502	5613-2320L(F)	2SC2320L(F)
Q503	5613-2603(F)	2SC2603(F)
Q504	5613-2603(F)	2SC2603(F)
Q505	5613-2603(F)	2SC2603(F)
Q506	5613-2603(F)	2SC2603(F)
Q701	5613-1845(E)	2SC1845(E)
Q702	5613-1845(E)	2SC1845(E)
Q703	5613-1845(E)	2SC1845(E)
Q704	5613-1845(E)	2SC1845(E)
Q705	5613-2603(F)	2SC2603(E)
Q706	5613-2603(F)	2SC2603(E)
Q707	5613-2603(F)	2SC2603(E)
Q708	5613-2603(F)	2SC2603(E)
Q709	5613-2878(B)	2SC2878(B)
Q710	5613-2878(B)	2SC2878(B)
Q711	5613-2878(B)	2SC2878(B)
Q712	5613-2878(B)	2SC2878(B)
Q801	5613-RN1203	RN1203
Q802	5611-RN2203	RN2203
Q803	5611-970(BL)	2SA970(BL)
Q804	5613-RN1203	RN1203
Q805	5611-RN2203	RN2203
Q806	5613-2603(F)	2SC2603(F)
Q807	5612-561(C)	2SB561(C)
Q808	5613-RN1203	RN1203
Q809	5612-561(C)	2SB561(C)
Q810	5612-561(C)	2SB561(C)
Q811	5611-RN2203	RN2203
Q812	5613-RN1203	RN1203
Q813	5613-RN1203	RN1203
Q814	5613-RN1203	RN1203
	DIODES	
D1	5685-1F	Bridge Silicon, SIRBA
D2	5635-HZ12C2L	ZD, HZ12C2L
D3	5635-HZ12C2L	ZD, HZ12C2L
D4	5635-HZ11B2L	ZD, HZ11B2L
D51	5636-MC921	MC921
D52	5635-RD12EB2	ZD, RD12EB2
D53	5631-1S2473	1S2473
D101	5635-HZ11B2L	ZD, HZ11B2L
D201	5631-1S2473	1S2473
D202	5631-1S2473	1S2473

Ref. No.	Part No.	Description
D251	5631-1S2473	1S2473
D501	5635-HZ6A1L	ZD, HZ6A1L
D701	5631-1S2473	1S2473
D702	5631-1S2473	1S2473
D703	5631-1S2473	1S2473
D704	5636-1S2471	1S2471
D705	5635-2R7EB2	ZD, RD2.7EB2
D706	5631-1S2473	1S2473
D707	5631-1S2473	1S2473
D709	5631-1S2473	1S2473
D710	5631-1S2473	1S2473
D801	5631-1S2473	1S2473
D802	5635-RD5R1EB2	ZD, RD5.1EB2
D803	5631-1S2473	1S2473
D804	5631-1S2473	1S2473
D805	5631-1S2473	1S2473
D806	5632-S5566B	S5566B
D807	5632-S5566B	S5566B
D808	5632-S5566B	S5566B
D809	5631-1S2473	1S2473
D810	5631-1S2473	1S2473
D811	5631-1S2473	1S2473
D812	5631-1S2473	1S2473
	COILS	
L101	5995-363156	36mH
L102	5995-363156	36mH
L201	5932-70223	3.3mH
L202	5932-70223	3.3mH
L203	5932-00224	
L204	5932-00224	
L501	5932-70215	
L502	5932-70215	
	MISCELLANEOUS	
LC501	5214-51	LC Components
LC502	5214-51	LC Components
OS101	6171-1506	Bias Osc.
J351,	4484-45	4-Pin Jack, Input, Output
J352,		
J353,		
J354		
LCN201	4163-08220029	CLW, 8 Pos.
LCN202	4163-08150029	CLW, 8 Pos.
CN103	4443-050185	Connector, 5 Pos.
CN104	4443-050185	Connector, 5 Pos.
CN105	4443-030185	Connector, 3 Pos.
CN106	4443-030185	Connector, 3 Pos.
CN107	4443-080185	Connector, 8 Pos.
CN108	4443-030185	Connector, 3 Pos.
CN110	4443-030185	Connector, 3 Pos.
CN111	4443-030185	Connector, 3 Pos.
CN301	4443-030185	Connector, 3 Pos.
CN302	4443-030185	Connector, 3 Pos.
	2132-7048	Spacer, R12
	4472-0131	Fuse Holder
PCB-2 FUNCTION SWITCH P.C. BOARD		
	CAPACITOR	
C569	5345-335F041	3.3 μ F/50V, EC
	MISCELLANEOUS	
MR801	5193-DM106A	Magnet Resistor
S201	4431-05107160	Push Switch, LN
S202	4431-05107160	Push Switch, CrO ₂
S203	4431-05107160	Push Switch, Metal
S501	4431-05107160	Push Switch, Dolby NR
S502	4431-05107160	Push Switch, NR Type
S801	4431-A010131	Push Switch, Pause
S802	4431-A010131	Push Switch, Stop
S803	4431-A010131	Push Switch, F.FWD
S804	4431-A010131	Push Switch, Play
S805	4431-A010131	Push Switch, REW
S806	4431-A010131	Push Switch, REC
S807	4431-A010131	Push Switch, REC Mute

Ref. No.	Part No.	Description
S808	4431-A027136	Push Switch, Auto Repeat
PCB-3 VR P.C. BOARD		
VR255	5113-20271159	Control, 2kΩB, Bias Fine Trim
VR353, VR354	5113-10471158	Control, 10kΩMN, Input Balance
S503	4431-A027336	Push Switch, MPX Filter
PCB-4 INPUT LEVEL CONTROL P.C. BOARD		
VR351, VR352	5224-503719	Control, 50kΩA, Input Level
PCB-5 POWER SWITCH P.C. BOARD		
△ C1	5361-1030419	0.01μF/AC 125V, CC U A
△ C1	5352-1030958	0.01μF/AC 250V, MPC EW
△ S1	4431-A01056	Push Switch, Power
PCB-6 DOLBY NR IND. P.C. BOARD		
D402	5637-GL9PG19	LED, GL9PG19, Green, Dolby B NR
D406	5637-GL9HY9	LED, GL9HY9, Amber, Dolby C NR
PCB-7 REC/PAUSE IND. P.C. BOARD		
D403 D404	5637-GL9PR9 5637-GL9HY9	LED, GL9PR9, Red, REC LED, GL9HY9, Amber, Pause
PCB-8 POWER IND. P.C. BOARD		
D405	5637-GL5HD5	LED, GL5HD5, Red, Power
PCB-9 HEADPHONES JACK P.C. BOARD		
J301	4451-00159	Jack, Headphones

KEY TO ABBREVIATIONS

FR : Fuse Resistor
 MR : Metal Resistor
 CR : Cement Resistor

EC : Electrolytic Capacitor
 PC : Polypropylene Capacitor
 MC : Mica Capacitor
 CC : Ceramic Capacitor
 MPC : Metalized Polyester Capacitor

ZD : Zener Diode

CLW : Connector with Lead Wire

U : U.S.A. model

A : Canada model

EW : General model

* The part with the above mark is used only in the model made for the particular market the mark indicates.

△ SAFETY RELATED COMPONENT. USE ONLY EXACT REPLACEMENT PART AS SPECIFIED.