

The Harman Kardon Model TL8600

Manual 170A

COMPACT DISC CHANGER

Technical Manual

TL8600

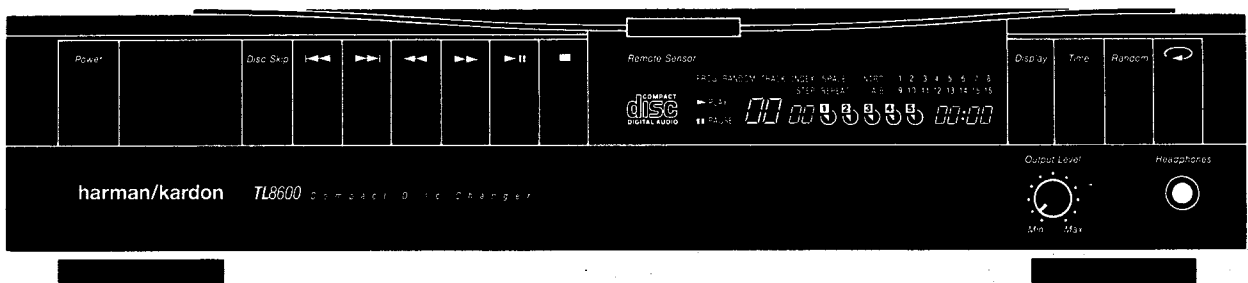

The following marks found in the parts list of this manual identify the models as follows.

- BK : North America area model Black version
- WB : Asia / Oceania model Black version

harman/kardon

240 Crossways Park West, Woodbury, N. Y. 11797
1112-3152170A3 P-119109 2000 Printed in Japan

CLASS 1 LASER PRODUCT

Product complies with DHHS rules CFR subchapter J part 1040: 10 at date of manufacture.

DANGER—invisible laser radiation when opened and interlock failed or defeated. Avoid direct exposure to beam.

CAUTION—use of all controls, adjustments or performance of procedures other than those specified herein may result in hazardous radiation exposure.

**CLASS 1
LASER PRODUCT**

Care of the Laser Pickup.

The laser pickup that detects the music recorded on a CD is located under the compact disc carousel. The laser pickup, especially its precision lens, is particularly sensitive to dust. Keep the top cover closed when the unit is not in use.

ADVARSEL:

Usynlig Laserstråling ved åbning når sikkerhedsafbrydere er ude af funktion. Undgå udsættelse for stråling.

VAROITUS!

Laitte sisältää laseriodin, joka lähettää näkymätöntä silmille vaarallista lasersäteilyä.

SPECIFICATION

Line Output Level	: 2.0V/10k Ω
Frequency Response	: 4Hz to 20kHz +0dB/-0.2dB
Dynamic Range	: 98dB
Signal to Noise Ratio	: 104dB
Total Harmonic Distortion (THD)	: 0.003%
Channel Separation	: 96dB
D/A Converter	: Dual, Linear, Pulse Width Modulated Bit Stream
Clock Rate	: 33.8688MHz (33,868.8kHz)

Power Supply

U. S. A. and Canada models	: AC120V, 60Hz
Asia / Oceania models	: AC220/240V, 50/60Hz
Power Consumption	: 20 Watts
Dimensions	: 17-3/8" x 4" x 16-1/8" (443 x 100 x 410 mm)
Weight	: 14.9 lbs (6.8 kg)

Specifications and components subject to change without notice. Overall performance will be maintained or improved.

■ Equipment and tools used for adjustment

- Servo gain adjuster (See page 12)
- Test disc
(EIAJ CD-1, Philips Test Sample 5A814 126-2)
- Commercial music disc
- Dual channel oscilloscope (minimum frequency 30MHz, with EXT trigger and 1:1 probe)
- Low-frequency oscillator
- Hex wrench (M2.0)
- Hex wrench (M1.27)
- Feeler gauge 0.9mm

SAFETY PRECAUTIONS

Before returning an instrument to the customer, always make a safety check of the entire instrument, including, but not limited to, the following items:

a. Be sure that no built-in protective devices are defective and/or have been defeated during servicing.

- (1) Protective shields are provided to protect both the technician and the customer. Correctly replace all missing protective shields, including any removed for servicing convenience.
- (2) When reinstalling the chassis and/or other assembly in the cabinet, be sure to put back in place all protective devices, including, but not limited to, nonmetallic control knobs, insulating fishpapers, adjustment and compartment covers/shields, and isolation resistor/capacitor networks.

Do not operate this instrument or permit it to be operated without all protective devices correctly installed and functioning.

b. Be sure that there are no cabinet openings through which an adult or child might be able to insert their fingers and contact a hazardous voltage. Such openings include, both are not limited to excessively wide cabinet ventilation slots, and an improperly fitted and/or incorrectly secured cabinet back over.

c. **Leakage Current Hot Check** — With the instrument completely reassembled, plug the AC line cord directly into a 120V AC outlet. (Do not use an isolation transformer during this test.) Use a leakage current tester or a metering system that complies with American National Standards Institute (ANSI) C101.1 "Leakage Current for Appliances" and Underwriters Laboratories (UL) 1270, (34.6). With the instrument AC switch first in the ON position and then in the OFF position, measure from a known earth ground (metal waterpipe, conduit, etc.) to all exposed metal parts of the instrument (antennas, handle bracket, metal cabinet, screwheads, metallic overlays, control shafts, etc.), especially any exposed metal parts that offer an electrical return path to the chassis. Any current measured must not exceed 0.5 milliamp. Reverse the instrument power cord plug in the outlet and repeat test. **ANY MEASUREMENTS NOT WITHIN THE LIMITS SPECIFIED HEREIN INDICATE A POTENTIAL SHOCK HAZARD THAT MUST BE ELIMINATED BEFORE RETURNING THE INSTRUMENT TO THE CUSTOMER.**

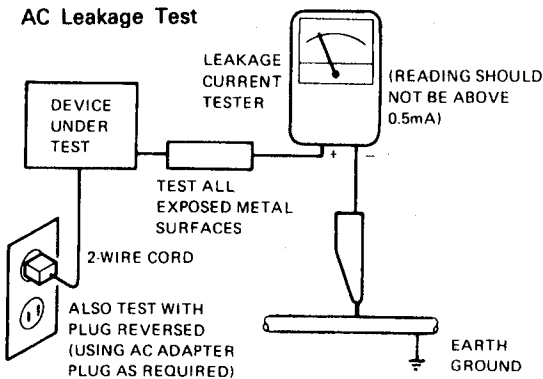

d. Insulation Resistance Test

- (1) Unplug the power supply cord and connect a jumper wire between the two prongs of the plug.
- (2) Turn on the power switch of the instrument.
- (3) Measure the resistance with an ohmmeter between the jumpered AC plug and each **exposed metallic** cabinet part on the instrument, such as screwheads, antenna, control shafts, handle brackets, etc. The reading should be as shown below. If it is not within the limits specified, there is the possibility of a shock hazard, and the instrument must be repaired and rechecked before it is returned to the customer.

e. Insulation Resistance Test Cold Check

- (1) Unplug the power supply cord and connect a jumper wire between the two prongs of the plug.
- (2) Turn on the power switch of the instrument.
- (3) Measure the resistance with an ohmmeter between the jumpered AC plug and each **exposed metallic** cabinet part on the instrument, such as screwheads, antenna, control shafts, handle brackets, etc. When the exposed metallic part has a return path to the chassis, the reading should be between 1 and 5.2 Megohm. When there is no return path to the chassis, the reading must be "infinite". If it is not within the limits specified, there is the possibility of a shock hazard, and the instrument must be repaired and rechecked before it is returned to the customer.

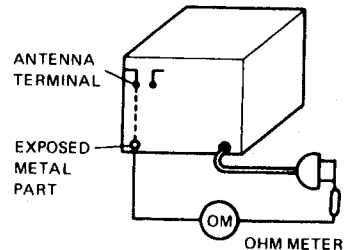

PRODUCT SAFETY NOTICE

Some electrical and mechanical parts have special safety related characteristics which are often not evident from visual inspection, nor can the protection they give necessarily be obtained by replacing them with components rated for higher voltage, wattage, etc. Parts that have special safety characteristics are identified by shading, by (Δ) on schematics and parts listed. Use of a substitute replacement that does not have the same safety characteristics as the recommended replacement part might create shock, fire, and/or other hazards. Products Safety is under review continuously and new instructions are issued whenever appropriate.

SERVICING PRECAUTIONS

CAUTION: Before servicing instruments covered by this manual and its supplements, read and follow the SAFETY PRECAUTIONS on this page.

NOTE: If unforeseen circumstances created conflict between the following servicing precautions and any of the safety precautions, **always follow the safety precautions.**

Remember: Safety First.

General Servicing Precautions

- a. Always unplug the instrument AC power cord from the AC power source before:
 - (1) Removing or reinstalling any component, circuit board, module, or any other instrument assembly.
 - (2) Disconnecting or reconnecting any instrument electrical plug or other electrical connection.
 - (3) Connecting a test substitute in parallel with an electrolytic capacitor in the instrument.

Caution: A wrong part substitution or incorrect polarity installation of electrolytic capacitors may result in an explosion hazard.
- b. Do **not** defeat any plug/socket B+ voltage interlocks with which instruments covered by this manual might be equipped.
- c. Do **not** apply AC power to this instrument and/or any of its electrical assemblies unless all solid-state device heat sinks are correctly installed.
- d. Always connect a test instrument's ground lead to the instrument chassis ground before connecting the test instrument positive lead. Always remove the test instrument ground lead last.

NOTE: Refer to Safety Precautions on page 3.

- (1) The service precautions are indicated or printed on the cabinet, chassis or components. When servicing, follow the printed or indicated service precautions and service materials.
- (2) The Components used in the unit has a specified conflammability and dielectric strength. When replacing any components, use components which has the same ratings. Components marked (Δ) in the circuit diagram are important for safety or for the characteristics of the unit. Always replace with the appointed components.
- (3) An insulation tube or tape is sometimes used and some components are raised above the printed wiring board for safety. The internal wiring is sometimes clamped to prevent contact with heating components. Install them as they were.
- (4) After servicing, always check that the removed screws, components and wiring have been installed correctly and that the portion around the service part have not been damaged and so on. Further check the insulation between the blades of attachment plug and accessible conductive parts.

Insulation Checking Procedure

Disconnect the attachment plug from the AC outlet and turn the power on. Connect the insulation resistance meter (500V) to the blades of the attachment plug. The insulation resistance between the each blade of the attachment plug and accessible conductive parts (Note 1) should be more than 1M-ohm.

Note 1: Accessible Conductive Parts including Metal panels, Output jacks, etc.

ELECTROSTATICALLY SENSITIVE (ES) DEVICES

Some semiconductor (solid state) devices can be damaged easily by static electricity. Such components commonly are called Electrostatically Sensitive (ES) Devices. Examples of typical ES devices are integrated circuits and some fieldeffect transistors and semiconductor "chip" components. The following techniques should be used to help reduce the incidence of component damage caused by static electricity.

1. Immediately before handling any semiconductor component or semiconductor-equipped assembly, drain off any electrostatic charge on your body by touching a known earth ground. Alternatively, obtain and wear a commercially available discharging wrist strap device, which should be removed for potential shock reasons prior to applying power to the unit under test.
 2. After removing an electrical assembly equipped with ES devices, place the assembly on a conductive surface such as aluminum foil, to prevent electrostatic charge buildup or exposure of the assembly.
 3. Use only a grounded-tip soldering iron to solder or unsolder ES devices.
 4. Use only an anti-static solder removal device. Some solder removal devices not classified as "anti-static" can generate electrical charges sufficient to damage ES devices.
 5. Do not use freon-propelled chemicals. These can generate electrical charge sufficient to damage ES devices.
 6. Do not remove a replacement ES device from its protective package until immediately before you are ready to install it. (Most replacement ES devices are packaged with leads electrically shorted together by conductive foam, aluminum foil or comparable conductive material).
 7. Immediately before removing the protective material from the leads of a replacement ES device, touch the protective material to the chassis or circuit assembly into which the device will be installed.
- CAUTION:** Be sure no power is applied to the chassis or circuit, and observe all other safety precautions.
8. Minimize bodily motions when handling unpackaged replacement ES devices. (Otherwise harmless motion such as the brushing together of your clothes fabric or the lifting of your foot from a carpeted floor can generate static electricity sufficient to damage an ES device).

CONTROLS

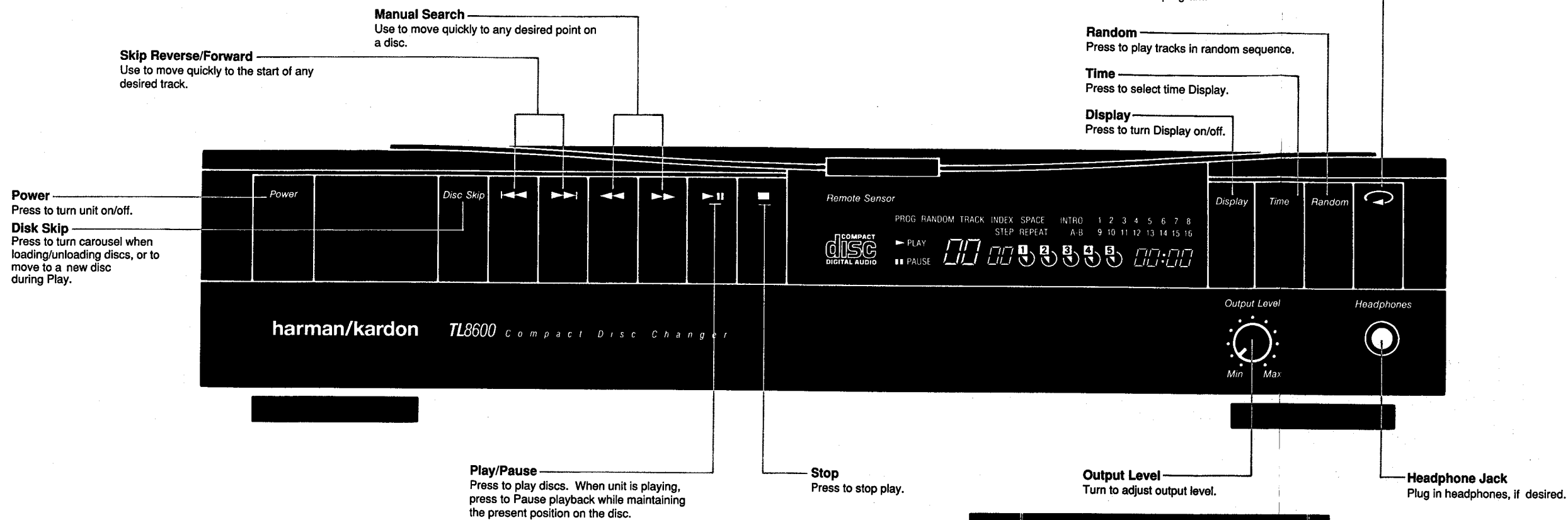

Disc Selectors
Press to choose desired disc.

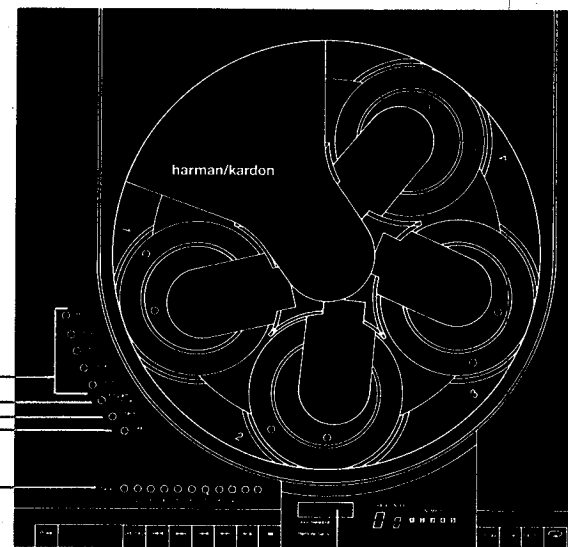

Door Release
Press to raise dustcover to load/unload discs.

Track Selectors
Press to choose desired tracks.

Clear
Press to erase tracks from memory.

Check
Press to review program in memory.

Program/Continue
Press Off for Continuous Play, On for Programming.

CONTROLS

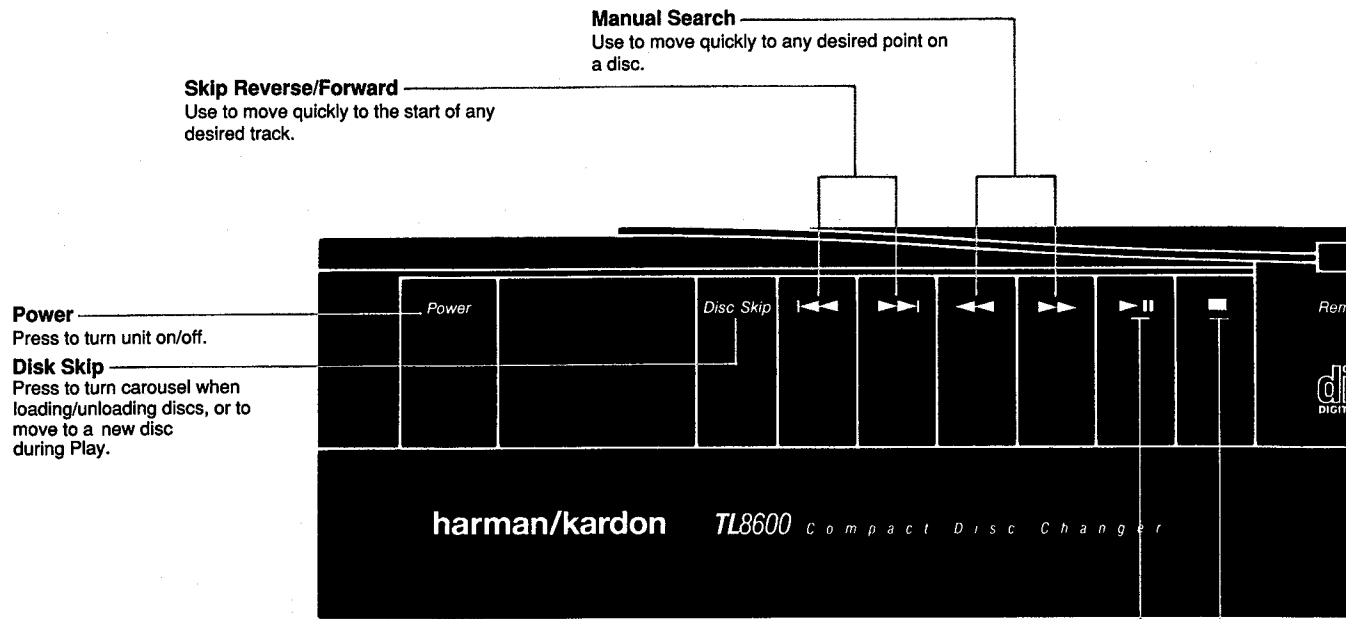

Power
Press to turn unit on/off.

Disk Skip
Press to turn carousel when loading/unloading discs, or to move to a new disc during Play.

Skip Reverse/Forward
Use to move quickly to the start of any desired track.

Manual Search
Use to move quickly to any desired point on a disc.

Play/Pause
Press to play discs. When unit is playing, press to Pause playback while maintaining the present position on the disc.

Stop
Press

Disc Sele
Press to ch

Repeat
Press to replay entire contents of carousel or program.

Random
Press to play tracks in random sequence.

Time
Press to select time Display.

Display
Press to turn Display on/off.

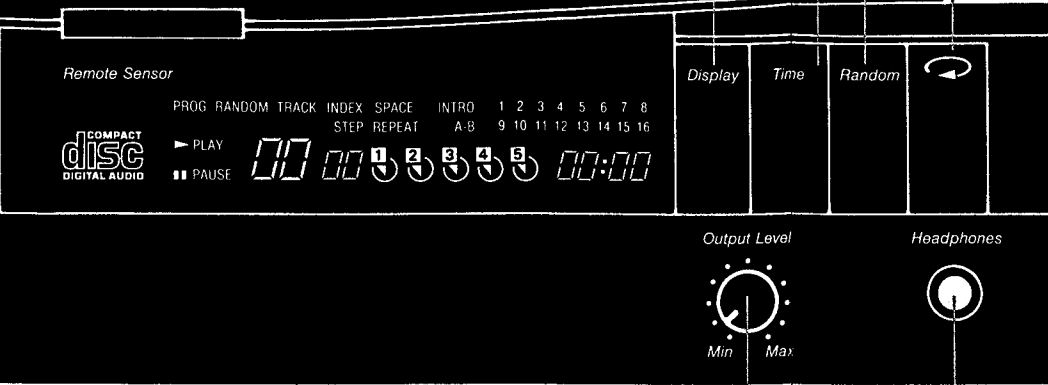

Stop
Press to stop play.

Output Level
Turn to adjust output level.

Headphone Jack
Plug in headphones, if desired.

Disc Selectors
Press to choose desired disc.

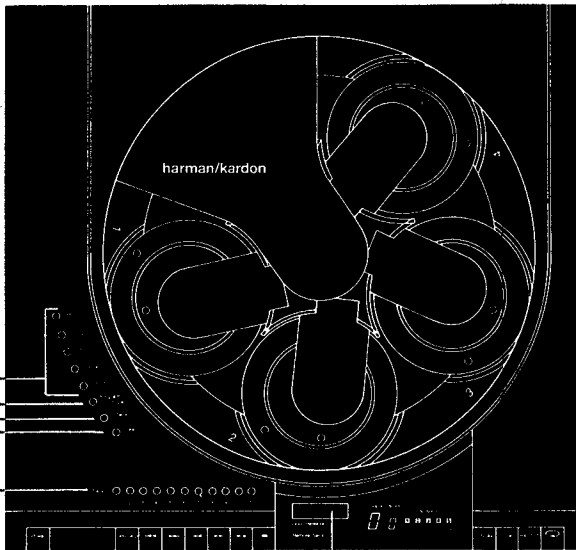

Door Release
Press to raise dustcover to load/unload discs.

Track Selectors
Press to choose desired tracks.

Clear
Press to erase tracks from memory.

Check
Press to review program in memory.

Program/Continue
Press Off for Continuous Play, On for Programming.

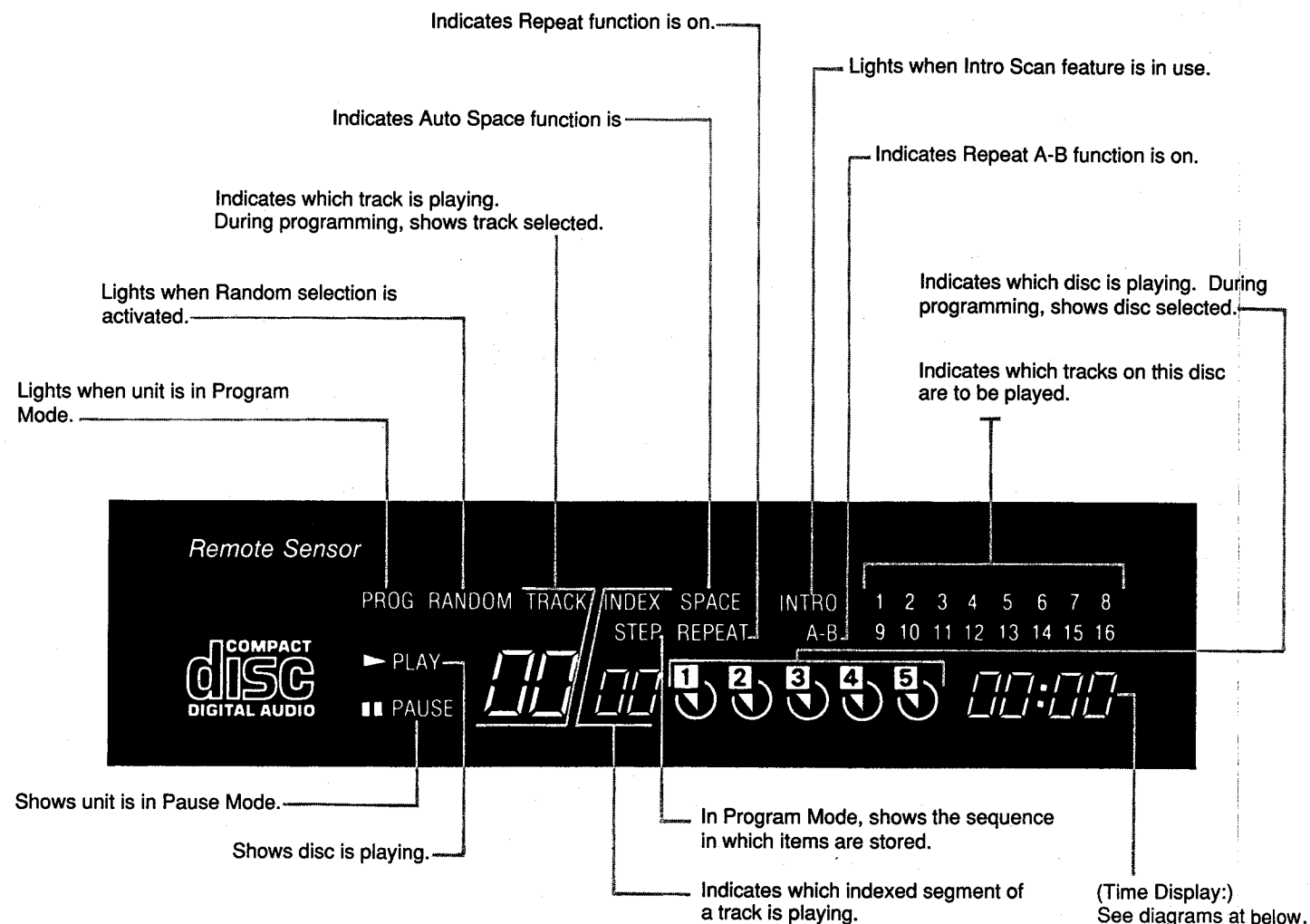

Time Display:
Press the time button to select among the following displays:



a. Elapsed time since the start of the track.

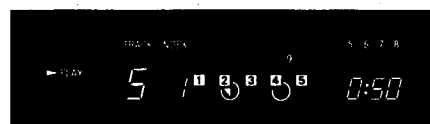

b. Time remaining until the end of the track.



c. Time remaining until the end of the disc.

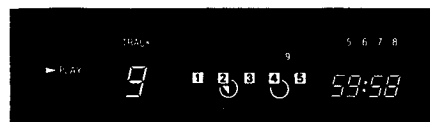

d. Total time of the disc (number of tracks is also displayed).

TOP DISPLAY (not shown)

Track, Index/Step and Disc indicators function exactly as in the front panel display.

REMOTE CONTROL

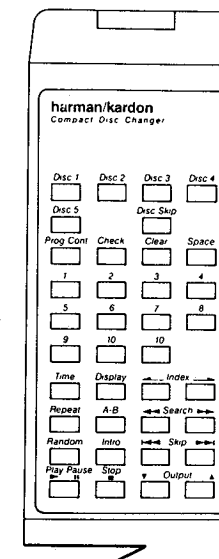

Function Buttons

The Remote Control provides the same functions as the CD changer, with the following exceptions:

- There is no Power switch on the Remote Control.
- The Remote Control provides two buttons, rather than a dial, to control Output Level. Press ▲ to raise, and ▼ to lower Output Level.
- The Remote Control provides five keys not found on the CD changer. These features are described below.

Previewing Disc(s) Using Intro Scan

When Intro is pressed, the CD changer automatically plays the first 15 seconds of each track on each disc, in order. In Program Mode, Intro Scan plays only the selected tracks, in the sequence programmed.

To cancel, press Intro again, if you wish the disc to continue playing from its present position. Or press Stop.

Repeating Selected Segments Using A-B

To repeat any desired segment:

- With unit playing, Press A-B key at the start of the desired segment. ("Repeat" and "A-" light up on the display.)
- Press key again at the end of the desired segment. ("B" also lights on display.) The designated section will be repeated continuously.

To cancel repeat and continue playing the disc, press Repeat or A-B. To stop play, press Stop.

The designated segment may be part of a single track, or may extend through several tracks on a single disc (Continuous Mode only). If no point B is set, the player will set point B at the end of the current disc in Continuous Mode; at the end of the current track in Program Mode.

Using Index Search

Some CDs contain long tracks that are subdivided into shorter segments, each identified by an Index number. When you are playing such a track, you may skip forward or back to the start of any desired index segment.

Press the Index → key to skip to a higher index segment; press ← to skip to a previous segment.

Using Auto Space

Some tape cassette players use the time interval between tracks to locate the beginning of a desired track. On many CDs, however, such spaces may not be present. If you wish to play a disc with spaces inserted, press the Space key on the Remote Control before or during playback. ("Space" will light up on display panel.) The player will automatically insert 4-second spaces between each track.

To cancel Auto Space, re-press the Space key. This feature is also canceled when Stop is pressed.

Operating Conditions

The control unit operates effectively within a distance of 7 meters (23 feet) and an angle of 30° from the CD changer. Using the control near fluorescent lights may shorten this range, as will any dust or dirt that accumulates on the front of the remote control, or the "Remote Sensor" area of the CD changer. Also avoid blocking the line of sight between the unit and the remote.

The control unit is powered by two AA batteries, included with your CD changer. When you replace weak batteries, replace both at the same time. When the remote is to be unused for an extended period, remove the batteries to prevent damage from corrosion.

DISPLAYS

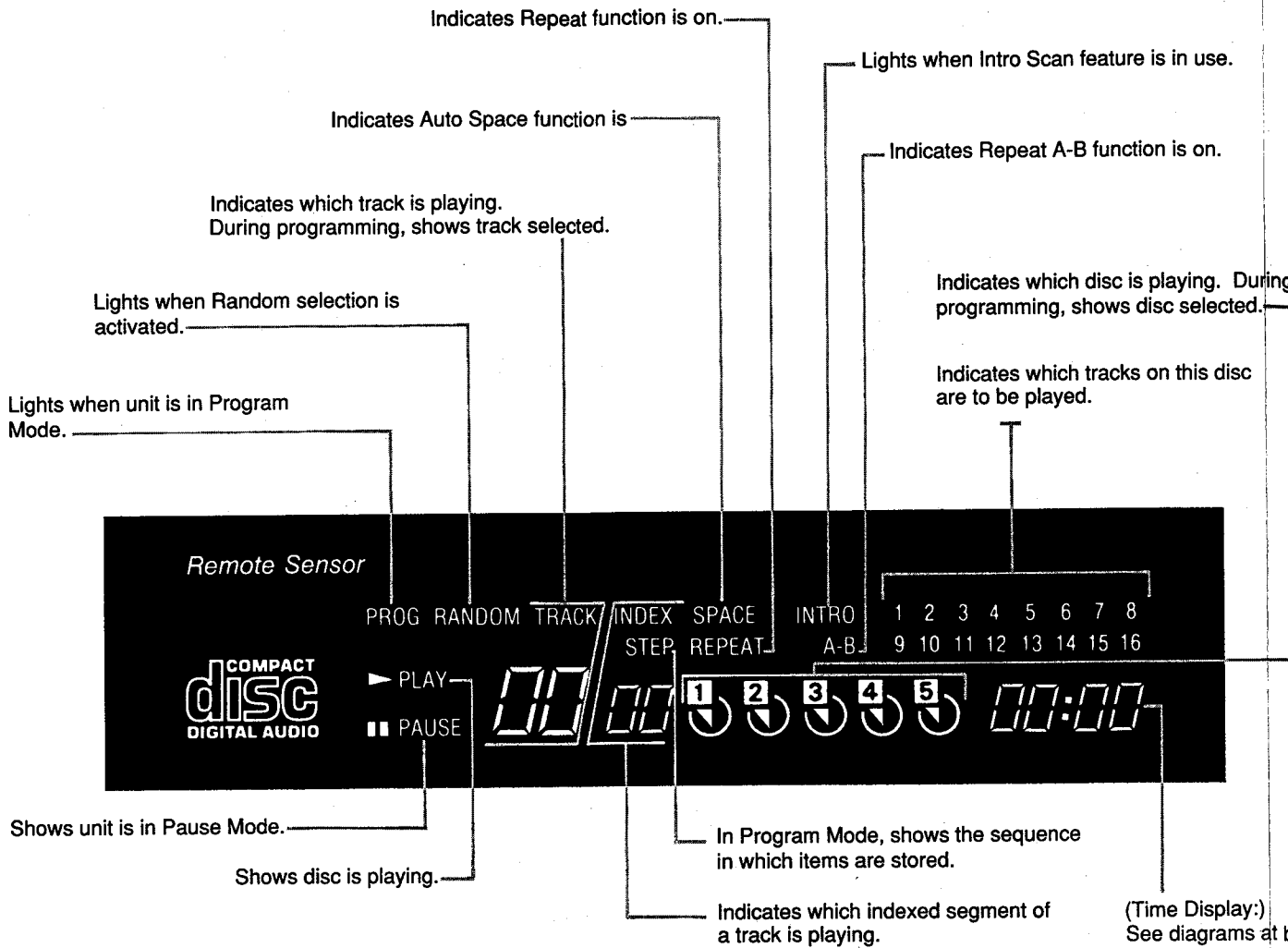

Time Display:

Press the time button to select among the following displays:

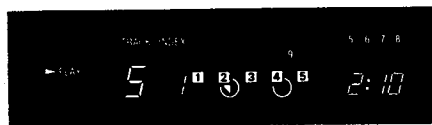

a. Elapsed time since the start of the track.

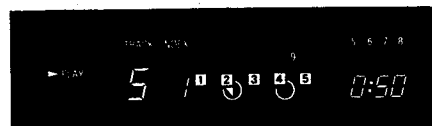

b. Time remaining until the end of the track.



c. Time remaining until the end of the disc.

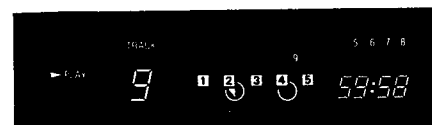

d. Total time of the disc (number of tracks is also displayed).

TOP DISPLAY (not shown)

Track, Index/Step and Disc indicator function exactly as in the front panel display.

REMOTE CONTROL

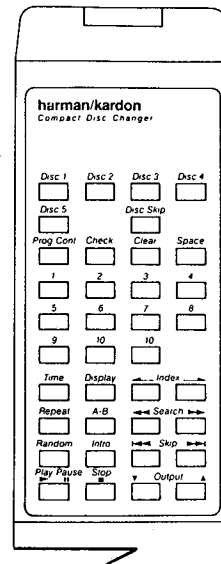

Function Buttons

The Remote Control provides the same functions as the CD changer, with the following exceptions:

- There is no Power switch on the Remote Control.
- The Remote Control provides two buttons, rather than a dial, to control Output Level. Press ▲ to raise, and ▼ to lower Output Level.
- The Remote Control provides five keys not found on the CD changer. These features are described below.

Previewing Disc(s) Using Intro Scan

When Intro is pressed, the CD changer automatically plays the first 15 seconds of each track on each disc, in order. In Program Mode, Intro Scan plays only the selected tracks, in the sequence programmed.

To cancel, press Intro again, if you wish the disc to continue playing from its present position. Or press Stop.

Repeating Selected Segments Using A-B

To repeat any desired segment:

- With unit playing, Press A-B key at the start of the desired segment. ("Repeat" and "A-" light up on the display.)
- Press key again at the end of the desired segment. ("B" also lights on display.) The designated section will be repeated continuously.

To cancel repeat and continue playing the disc, press Repeat or A-B. To stop play, press Stop.

The designated segment may be part of a single track, or may extend through several tracks on a single disc (Continuous Mode only). If no point B is set, the player will set point B at the end of the current disc in Continuous Mode; at the end of the current track in Program Mode.

Using Index Search

Some CDs contain long tracks that are subdivided into shorter segments, each identified by an Index number. When you are playing such a track, you may skip forward or back to the start of any desired index segment.

Press the Index → key to skip to a higher index segment; press ← to skip to a previous segment.

Using Auto Space

Some tape cassette players use the time interval between tracks to locate the beginning of a desired track. On many CDs, however, such spaces may not be present. If you wish to play a disc with spaces inserted, press the Space key on the Remote Control before or during playback. ("Space" will light up on display panel.) The player will automatically insert 4-second spaces between each track.

To cancel Auto Space, re-press the Space key. This feature is also canceled when Stop is pressed.

Operating Conditions

The control unit operates effectively within a distance of 7 meters (23 feet) and an angle of 30° from the CD changer. Using the control near fluorescent lights may shorten this range, as will any dust or dirt that accumulates on the front of the remote control, or the "Remote Sensor" area of the CD changer. Also avoid blocking the line of sight between the unit and the remote.

The control unit is powered by two AA batteries, included with your CD changer. When you replace weak batteries, replace both at the same time. When the remote is to be unused for an extended period, remove the batteries to prevent damage from corrosion.

DISASSEMBLY PROCEDURES (REFER TO PAGES 39, 40 AND 42)**[1] CABINET BOTTOM ASSEMBLY (AE) REMOVAL**

1. Remove special Boss (230) .
2. Remove 4 screws (A) and then remove the 4 Legs (133 and AA).
3. Remove 2 screws (B) and then remove the Bracket (203).
4. Remove 14 screws (C) and then remove the Cabinet Bottom (138).

[2] MAIN P. C. BOARD (PCB-1) REMOVAL

1. Remove the Cabinet Bottom Assembly (AE), referring to the previous step [1].
2. Disconnect the jumper leads (W111 and W112) connected to the connectors (CN111 and CN112) on the Main P. C. Board (PCB-1).
3. Disconnect the connector with lead wires (W104, LCN103, LCN104, LCN107, LCN108, LCN109, W501, W502, W504, W1, LCN121 and W503) connected to the connectors (CN101, CN103, CN104, CN107, CN108, CN109, CN117, CN118, CN119, CN120, CN121 and CN122) on the Main P. C. Board (PCB-1).
4. Disconnect the connector with lead wire (LCN102) connected to the connector (CN102) on the Disc Sensor P. C Board (PCB-5) .
5. Remove 9 screws (D) and then remove the Main P. C. Board (PCB-1).

[3] FRONT PANEL ASSEMBLY (AB) REMOVAL

1. Remove the Cabinet Bottom Assembly (AE), referring to the previous step [1].
2. Disconnect the jumper leads (W111 and W112) connected to the connectors (CN111 and CN112) on the Main P. C. Board (PCB-1).
3. Disconnect the jumper lead (W110) connected to the connector (CN113) on the 10 Key P. C. Board (PCB-13).
4. Remove 2 screws (E) and then remove the Open Lever Holder (224).
5. Remove 7 screws (F) and then, while pressing the Lid Open Button, remove the Front Panel Assembly (AB) with Front Chassis (183) and Power Switch P. C. Board (PCB-9).
6. Remove 13 screws (G) and then separate the Front Panel Assembly (AB) and Front Chassis (183) with P. C. Board.

[4] CD MECHANISM ASSEMBLY (308) REMOVAL

1. Remove the Cabinet Bottom Assembly (AE), referring to the previous step [1].
2. Disconnect the jumper lead (W104) connected to the connector (CN103) on the Servo P. C. Board. Disconnect the connector with lead wire (LCN121) connected to the connector (CN121) on the Main P. C Board (PCB-1).
3. Remove a screw (H) and then remove the Stopper (253).
4. Remove a screw (I) and then remove the CD Mechanism Assembly (308) with Holder Assembly (AK) and Slider Assembly (AL).
5. Remove 3 screws (J) and then separate the CD Mechanism Assembly (308) and Holder Assembly (AK) and Slider Assembly (AL).

Note: When fitting the CD Mechanism Assembly, make certain that the Up/Down Cam (247) is inserted between the holder (221) and the Up/Down Slider (248).

[5] TURN TABLE (142) REMOVAL

1. Remove 4 screws (K) and then remove Dust Cover (140) with the Metal Fittings and Hinges.
2. Remove the Pick Up Cover (141).
3. Remove 3 screws (L) and then remove the Bracket Assembly (AG) and Turn Table (142).
4. Disconnect the connector with lead wire (LCN102) to the connector (CN102) on the Disc Sensor P. C. Board (PCB-5).

Note: When putting the Turntable on the Cabinet Top, make certain that the Cabinet Top is flush with the Turntable. They will not be flush with each other if the external gear of the Turntable is resting on the Guide Roller. In such a case, turn the Turntable a few times to make them flush before assembling them.

[6] CLAMPER (239) REMOVAL

1. Remove the Bracket Assembly (AG), referring to the previous step [5].
2. Steadying the Clamper (239) by hand, turn the Bracket (193) using a screwdriver or the like, align 3 lugs of the Clamper (239) with notches on the Bracket (193), and then remove the Bracket (193).
3. Pry open 3 lugs of the Clamper (239) and remove the Magnet (309).
Note: When assembling the Magnet (309), make certain that the dented side faces down.
4. Pulling the Clamper (239) toward either side of the Bracket (191), press one of the Clamper lugs to the center of the Clamper to disengage it. Disengage another lug by the same method to separate the Clamper from the Bracket.

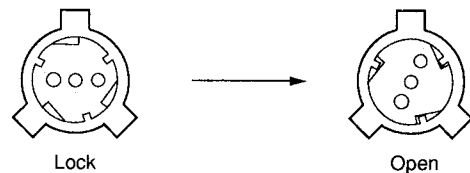

TROUBLE SHOOTING

When a trouble has occurred, first check the pick-up lens for dirt and each connector for tight and secure connection. If the problem persists after checking both of these items, use the following check procedures.

< PLAY operation >

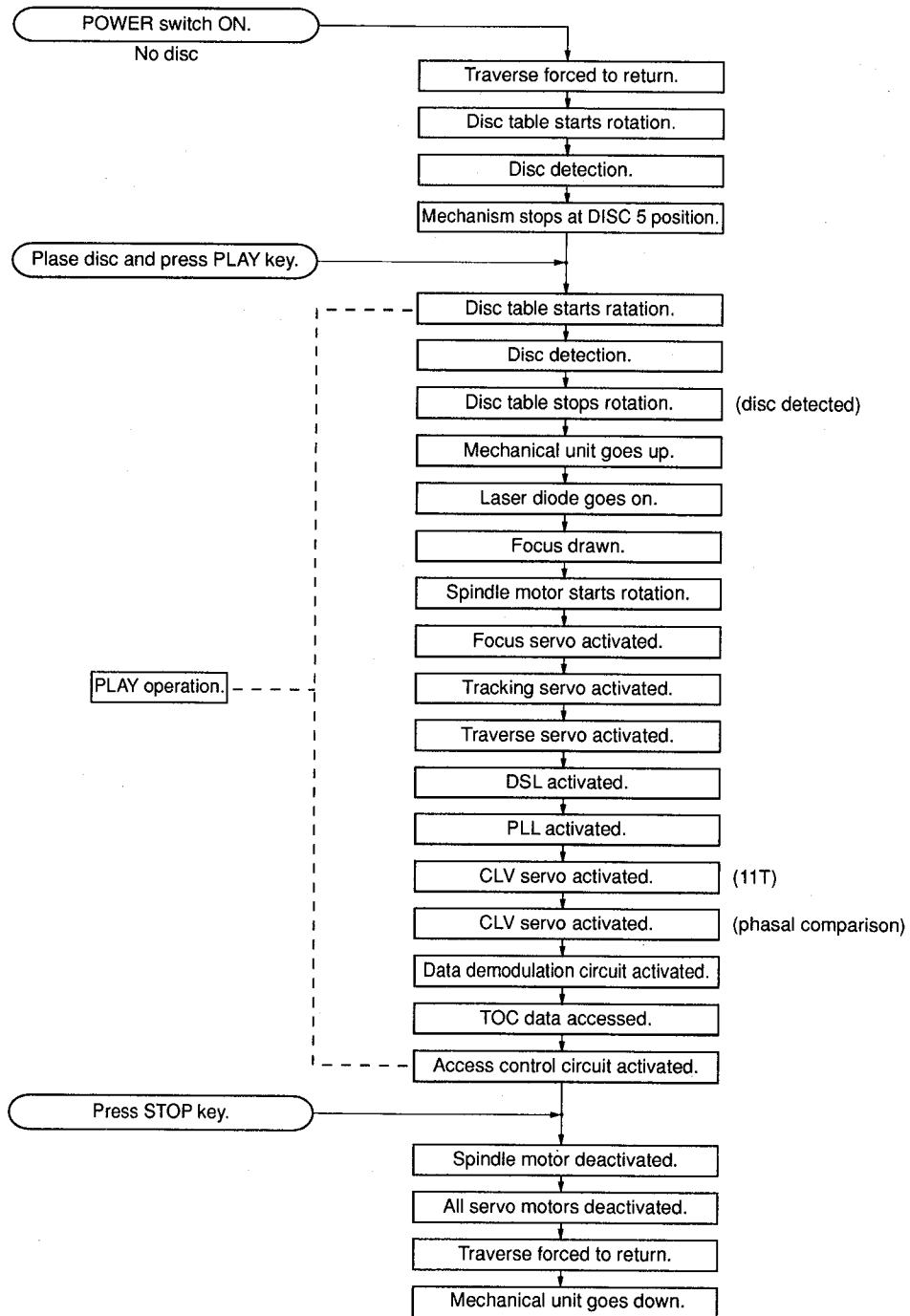

< Operation after POWER switch ON (without discs). >

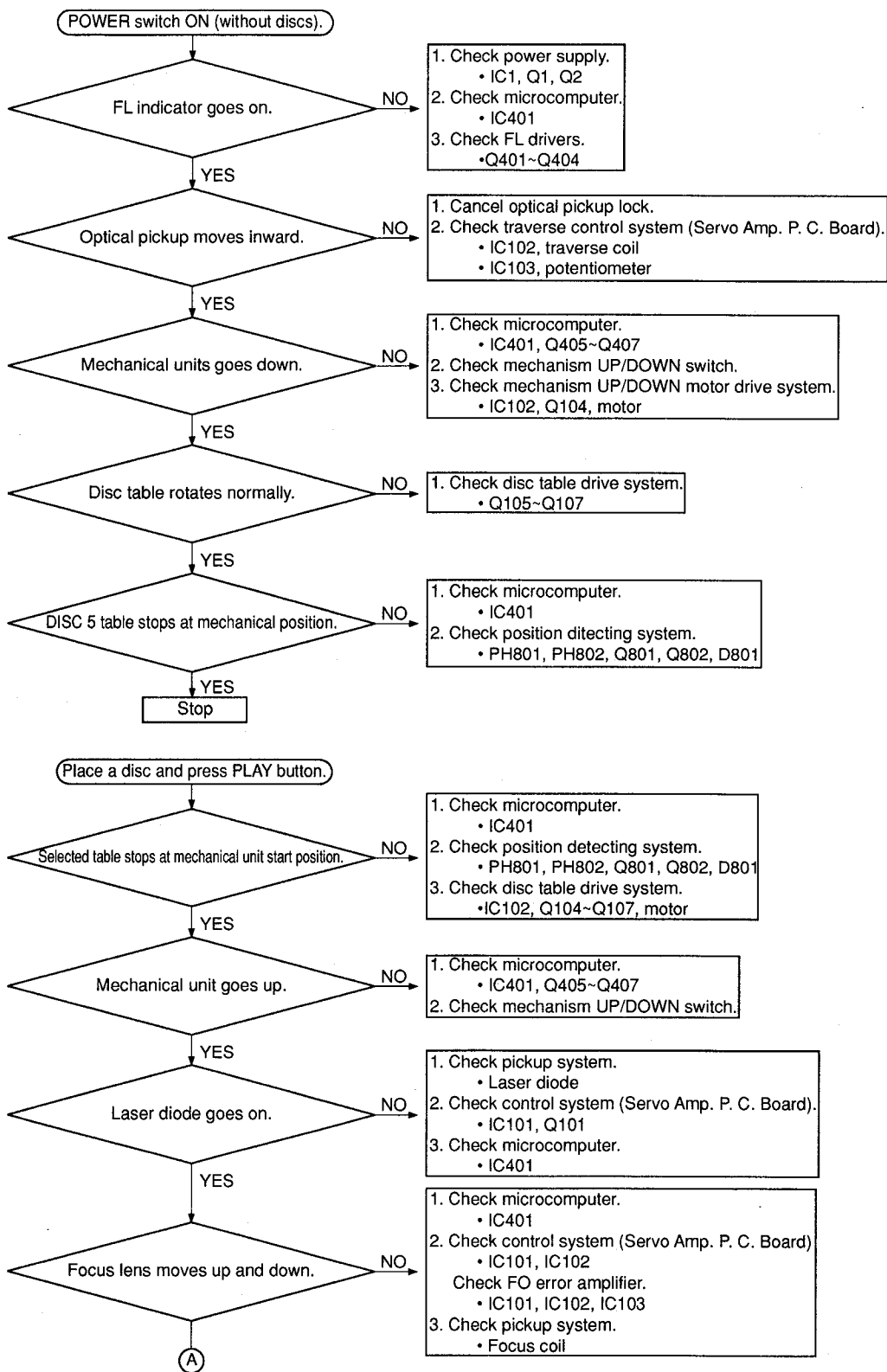

< TOC access to PLAY operation. >

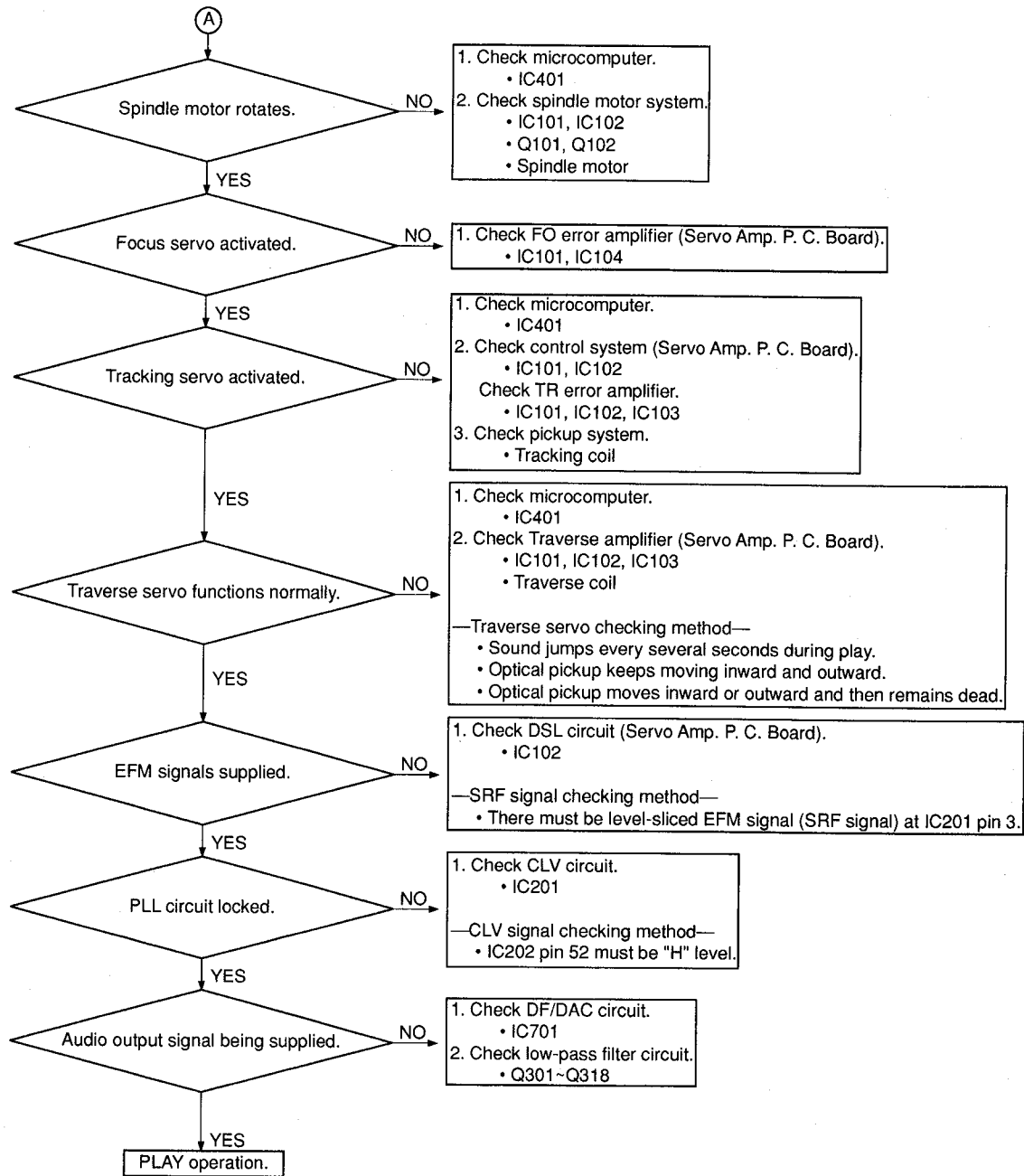

POWER CORD REPLACEMENT (FOR SERVICE ENGINEERS OTHER THAN NORTH AMERICA)

In order to prevent fire or shock hazard when replacing the power cord, follow the procedure below to replace the part with the standard supply parts.

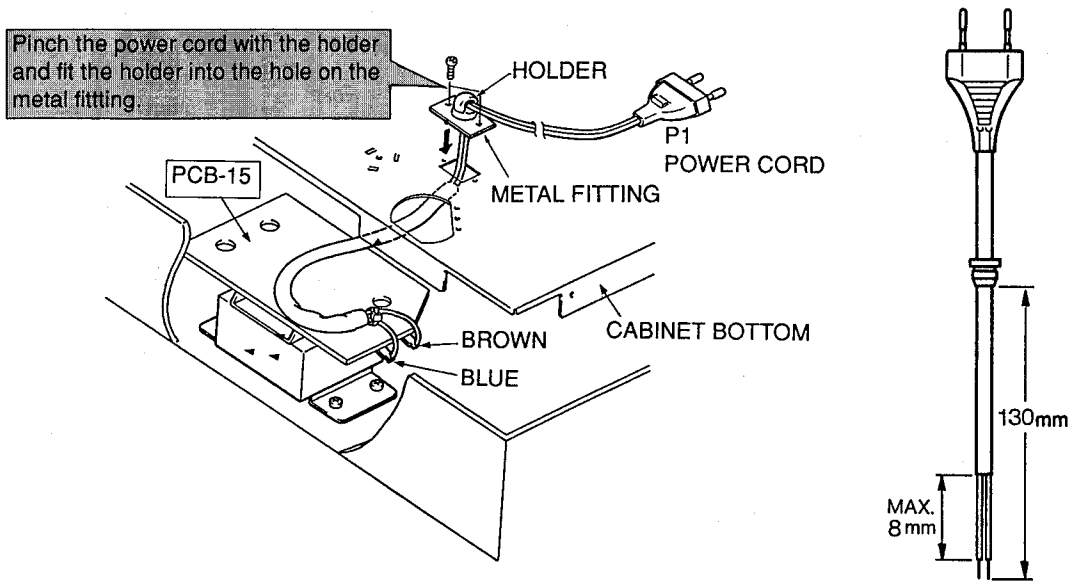

ALIGNMENT PROCEDURES

Caution: Laser beams are irradiated at power on from the pickup lens. Avoid direct eye or body contact with laser beams to protect yourself from danger.

■ Crucial Points of Adjustment

- Servo P. C. Board

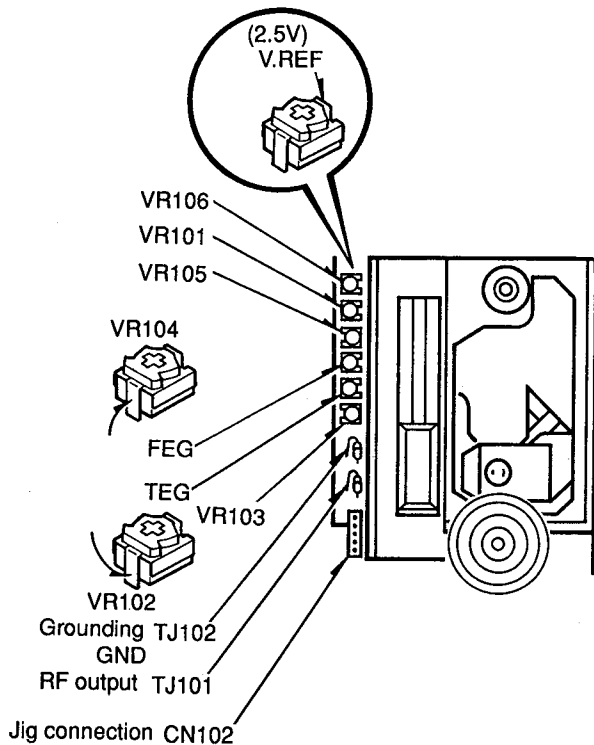

Fig. A

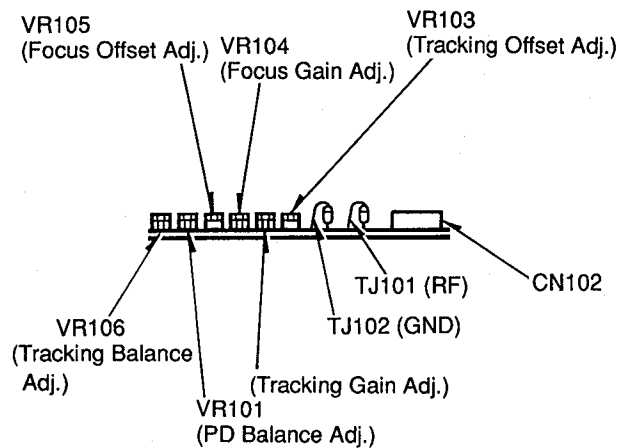

Fig. B

- Temporary VR settings (VR need to be adjusted temporarily when they are replaced or when they need major readjustment.)

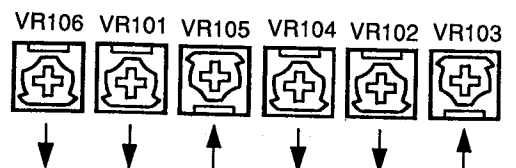

Fig. C

Alignment with TECHNICS SZZP1094C-1 Servo Adjuster.

TECHNICS SERVO GAIN ADJUSTER

■ Controls and their functions

Front View

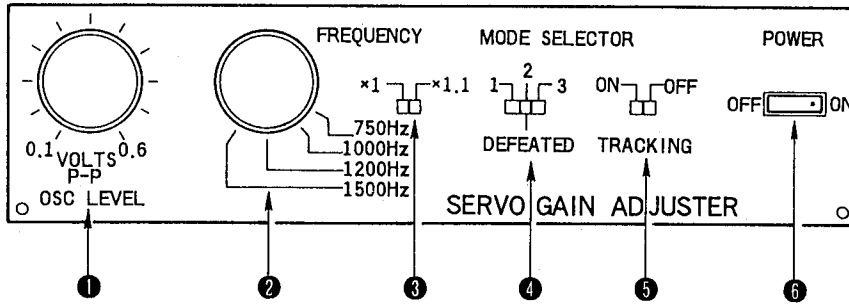

1 OSC LEVEL KNOB

Used to adjust the output level of the built-in low frequency oscillator.
At minimum position (fully-counterclockwise rotated position):

A 0.1 Vp-p level signal is delivered.

At maximum position (fully-clockwise rotated position):

A 0.6 Vp-p level signal is delivered.

4 MODE SELECTION SWITCH

Used to set the modes for tracking and focus servo adjustments.

1. Setting for tracking servo adjustment.

2. DEFEATED (through)

3. Setting for focus servo adjustment.

Note: The adjustment settings (1, 2 or 3) will depend on the model being used.

Please refer to respective Service Manual.

2 3 FREQUENCY KNOB AND SWITCH

x1 AND x1.1

Used to select the oscillation frequency.

FREQUENCY	Oscillation Frequency	
	x1	x1.1
750Hz	750Hz	825Hz
1,000Hz	1,000Hz	1,100Hz
1,200Hz	1,200Hz	1,320Hz
1,500Hz	1,500Hz	1,650Hz

5 TRACKING SWITCH

Used to turn on and off the tracking servo.

6 POWER SWITCH

Top View

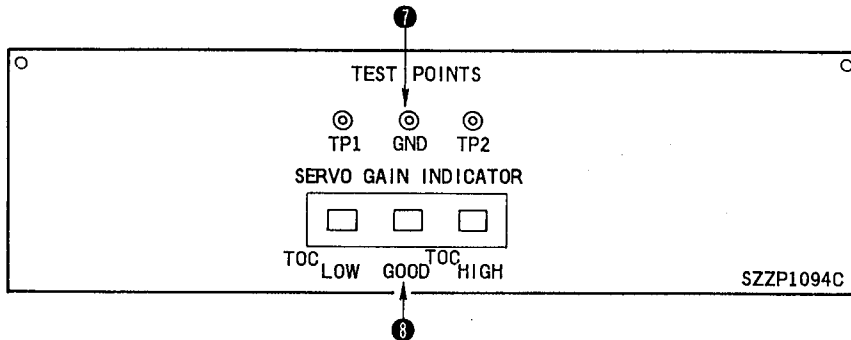

7 TEST POINTS

These are the in/output terminals for monitoring the servo amplifier. (Same T. P. s in the original Servo Gain Adjuster.)

8 SERVO GAIN INDICATOR

Displays the condition of the servo amplifier's gain during adjustment.

LED Status	Condition of the Servo Amplifier's Gain
LOW	Gain is low
GOOD	Gain is correct
HIGH	Gain is high

Alignment with TECHNICS SZZP1094C-1 Servo Adjuster.

For adjustment with Alternate Servo Adjuster see page 17.

Equipment and tools used for adjustment

- Servo gain adjuster (TECHNICS P/N : SZZP1094C or SZZP1094C-1) (See page 12)
- Test disc (EIAJ CD-1, Philips Test Sample 5A814 126-2, ABEX TCD-731R)
- Commercial music disc
- Dual channel oscilloscope (minimum frequency 30MHz, with EXT trigger and 1:1 probe)
- Low-frequency oscillator
- Hex wrench (M2.0)
- Hex wrench (M1.27)
- Feeler gauge 0.9mm (P/N : RZZ0297)

Steps of Adjustment

The CD changer needs to be adjusted as shown below when the optical pickup, the spindle motor, or the turntable is replaced.

Set Up instructions for Adjustment.

1. Defeat the Disc Detect Sensor by placing none transparent tape over 2 Disc Detect holes in one of the disc trays in Turntable Ref. No. 142. (See Fig. a)

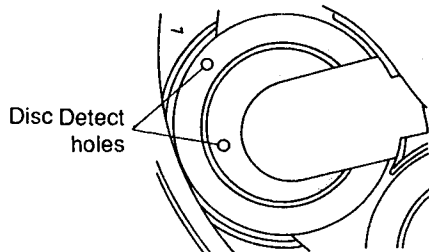

Fig. a

2. Place the unit upside down on small support blocks. (See Fig. b)

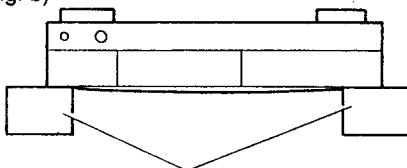

Fig. b

3. Remove bottom cover and remove CD transport. Do not disconnect any wires. (See Fig. c)

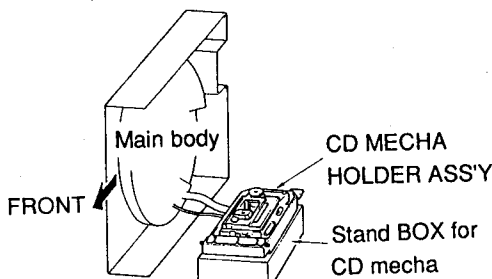

Fig. c

4. Lift stopper ass'y Ref. No. 253 and insert a 13 mm jam between stopper ass'y and chassis. This jam will allow the Turntable to rotate freely. (See Fig. d)

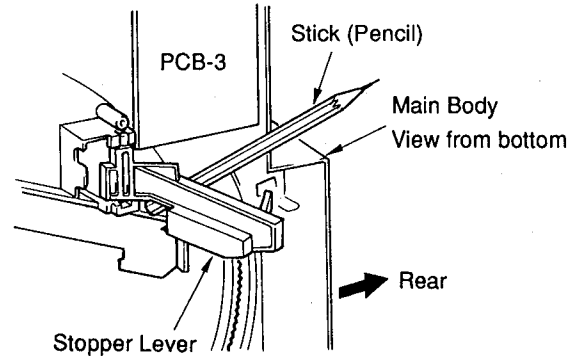

Fig. d

5. Turn on the power switch and wait until the Turntable stops rotating.
6. Place test disc on the disc spindle and hold the disc in place with a round magnet. (See Fig. e)

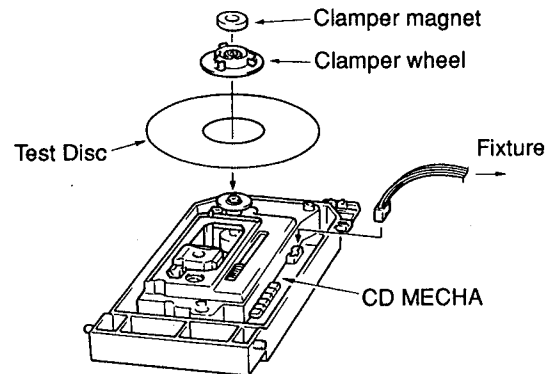

Fig. e

7. Press the Play button on front panel and wait until the Turntable stops rotating.
8. The CD transport is now in the play mode and ready for alignment.

[1] Turntable height check and adjustment

1. Put a 0.9mm feeler gauge between the turntable and the loading base (see Fig. D).
2. Tighten the turntable retaining screw using a hex wrench (M1.27).
3. Connect CH1 of the oscilloscope across VR104 (FEG) (+) and VR106 (V.REF)(-) of the servo P. C. Board.

Caution: Voltage (2.5V) is present at the V.REF terminal. Be certain that the changer chassis never touches the oscilloscope chassis.

Oscilloscope setting: VOLT50mV
 SWEEP....1msec.
 INPUT.....DC

4. Set the DC Zero Balance of the oscilloscope.
5. Turn on the power switch, and play a test disc.
6. Check the voltage of the oscilloscope waveform.

Note 1: The turntable height is correct if the measured voltage is $\pm 15\text{mV}$. If necessary, fine-adjust the turntable height (tilting the feeler gauge, etc.).
 Over +15mV Decrease the turntable height.
 Over -15mV Increase the turntable height.

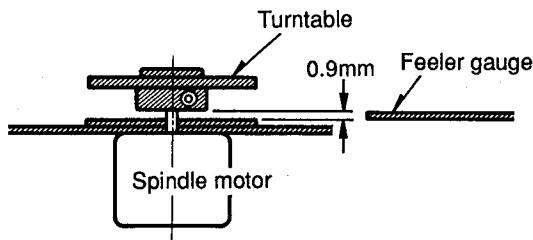

Fig. D

Note 2: If the measured voltage is beyond the range of target voltage even after fine-adjustment described in Note 1, set VR105 to a middle point and check the turntable height again. (In this case, the focus offset needs to adjusted later.)

[2] Pulsation adjustment

1. Connect CH1 of the oscilloscope across TJ101 (+) and TJ102 (-) of the servo P. C. Board.

Oscilloscope setting: VOLT100mV
 SWEEP....0.5 μ sec.
 INPUT.....AC

2. Turn on the power switch and play the test disc.
3. While playing the test disc, raise the player as shown.
4. Using a hex wrench (M2.0mm), turn the two pulsation adjusting screw alternately to minimize the amplitude fluctuation of the oscilloscope waveform (RF signal).
5. When adjustment is completed, apply liquid bond to fix the adjusting screws.

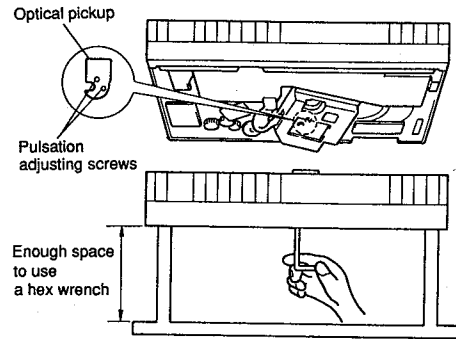

Fig. E

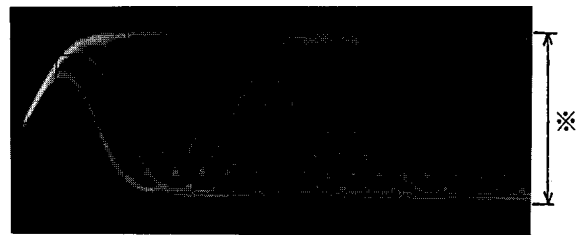

Fig. F

※ Minimize the amplitude fluctuation in this area.

[3] BEST EYE (PD balance) adjustment

1. Connect CH1 of the oscilloscope across TJ101 (+) and TJ102 (-) of the servo P. C. Board.

Oscilloscope setting: VOLT100mV
 SWEEP....0.5 μ sec.
 INPUT.....AC

2. Turn on the power switch and play the test disc. (Philips Test Sample 5A814 126-2, Scratched) (track number 15)
3. Adjust VR101 to maximize the amplitude of the RF signal eye patterns. (See figure G.)

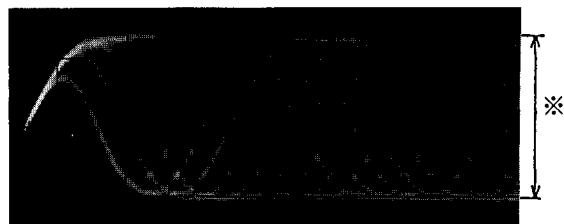

Fig. G

※ Maximize the amplitude in this area.

Alignment with TECHNICS SZZP1094C-1 Servo Adjuster.

[4]Focus gain adjustment

1. Connect the servo gain adjuster (see page 16).
2. Set the mode selector switch to 2 (maintaining the adjuster tracking switch in the ON position).
3. Adjust the low-frequency oscillator to 825Hz (frequency) and 150mVp-p (output level).
4. Play a test disc. (EIAJ CD-1)
5. Set the mode selector switch on the panel of the unit to position "3" and adjust the semi fixed volume (VR104) for Focus Gain control on the CD player so that the LED "GOOD" on the SERVO GAIN INDICATOR Panel lights up.

Note: First adjust the volume for Focus Gain Control so that the LOW LED on the SERVO GAIN INDICATOR Panel lights up and then make further adjustments until the GOOD LED lights up.

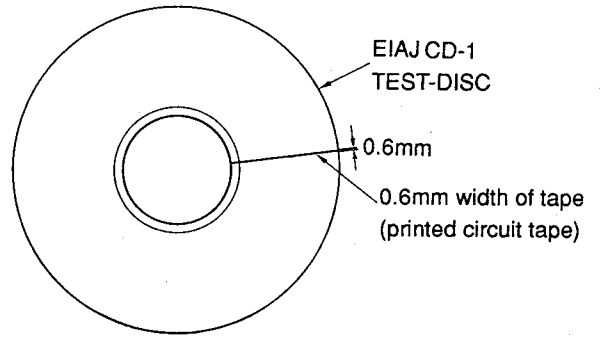

3. Trigger the oscilloscope to get the waveforms shown below. Then adjust VR105 so that the RF dimple in CH1 is smoothly enveloped and the amplitude of CH2 is minimized, or so that A equals to B.

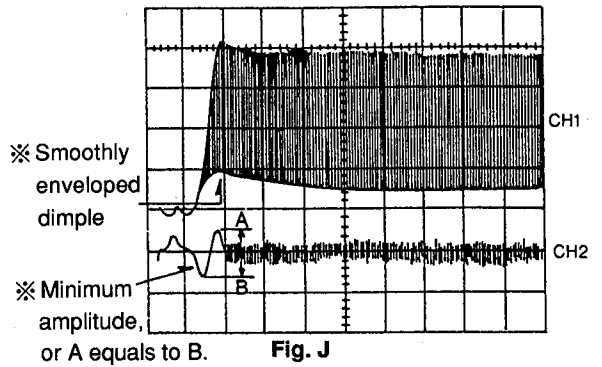

[5]Tracking gain adjustment

1. Adjust the low-frequency oscillator to 1.1kHz (frequency) and 150mVp-p (output level).
2. Set the mode selector switch to 2 (maintaining the adjuster tracking switch in the ON position).
3. Turn on the power switch and play a test disc. (EIAJ CD-1)
4. Set the Mode Selector Switch on the unit panel to position "1" (for tracking servo adjustment) and adjust the semi fixed volume (VR102) for the tracking gain of the CD player until the GOOD LED of the Servo Gain Indicator lights up.

Note: First adjust the semi fixed volume for Tracking Gain control so that the LOW LED on the SERVO GAIN INDICATOR Panel lights up and then make further adjustments until the GOOD LED lights up.

[7]Tracking offset adjustment

1. Connect CH1 of the oscilloscope to TJ101 (+) and TJ102 (-) of the servo P. C. Board; connect CH2 to VR102 (TEG) (+).
Oscilloscope setting: VOLT100mV (CH1 and CH2)
SWEEP....0.5msec.
INPUT.....AC (CH1 and CH2)
MODE.....NORM (CH1 trigger)
2. Turn on the power switch and play the test disc. (EIAJ CD-1 with putting a 0.6mm width of tape, track number 6)
3. Trigger the oscilloscope to get the waveforms shown below. Then adjust VR103 so that the RF dimple in CH1 is smoothly enveloped and the amplitude of CH2 is minimized, or so that A equals to B.

[6]Focus offset adjustment

1. Connect CH1 of the oscilloscope to TJ101 (+) and TJ102 (-) of the servo P. C. Board; connect CH2 to VR104 (FEG) (+).
Oscilloscope setting: VOLT100mV (CH1 and CH2)
SWEEP....0.5msec.
INPUT.....AC (CH1 and CH2)
MODE.....NORM (CH1 trigger)
2. Play track number 6 of the EIAJ CD-1 test disc with a 0.6mm width of tape.

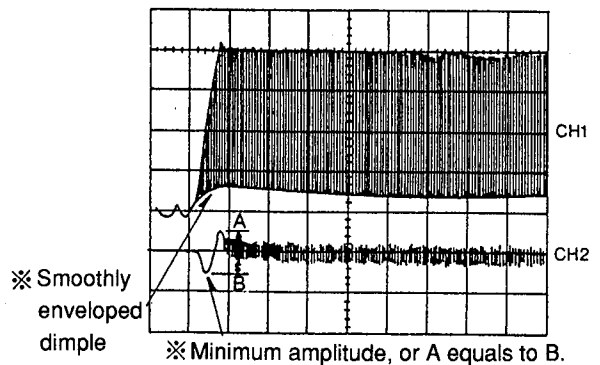

Alignment with TECHNICS SZZP1094C-1 Servo Adjuster.

[8] Tracking balance adjustment

1. Make certain that the mode selector switch is set to 2.
2. Adjust the low-frequency oscillator to 1.1kHz (frequency) and 600mVp-p (output level).
3. Connect CH1 of the oscilloscope to TJ101 (+) and TJ102 (-) of the servo P. C. Board; connect CH2 to OSC of the servo gain adjuster.
Oscilloscope setting: VOLT100mV (CH1)
SWEEP....1msec.
INPUT.....AC (CH1 and CH2)
MODE.....NORM (CH2 trigger)
4. Turn on the power switch and play a test disc. (EIAJ CD-1)
5. Set the mode selector switch to 1, and adjust VR106 to get the waveforms for CH1 output as shown below (minimum jitter).
6. Disconnect the servo gain adjuster.

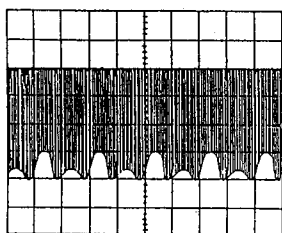

Fig. L

※ Align for minimum jitter.

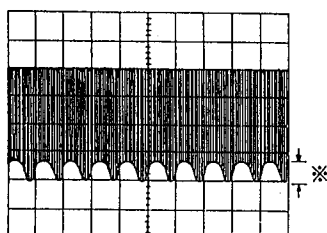

Fig. L1

※ Minimum jitter.

[9] Play confirmation after adjustment

- Skip search confirmation
 1. Play a commercial music disc.
 2. Operate the skip button to check the skip search function (forward and reverse).
- Manual search confirmation
 1. Play a commercial music disc.
 2. Push the manual search button to check smooth manual search operation at low and high speeds (forward and reverse).
- Defect check
 1. Play the test disc. (ABEX Vertical Deviation Test Disc TCD-731R, track number 1)
 2. Play the middle sections of Vertical Deviation test disc and check the player operation for track jumping and noise.

■ Wiring diagram of the Technics servo gain adjuster

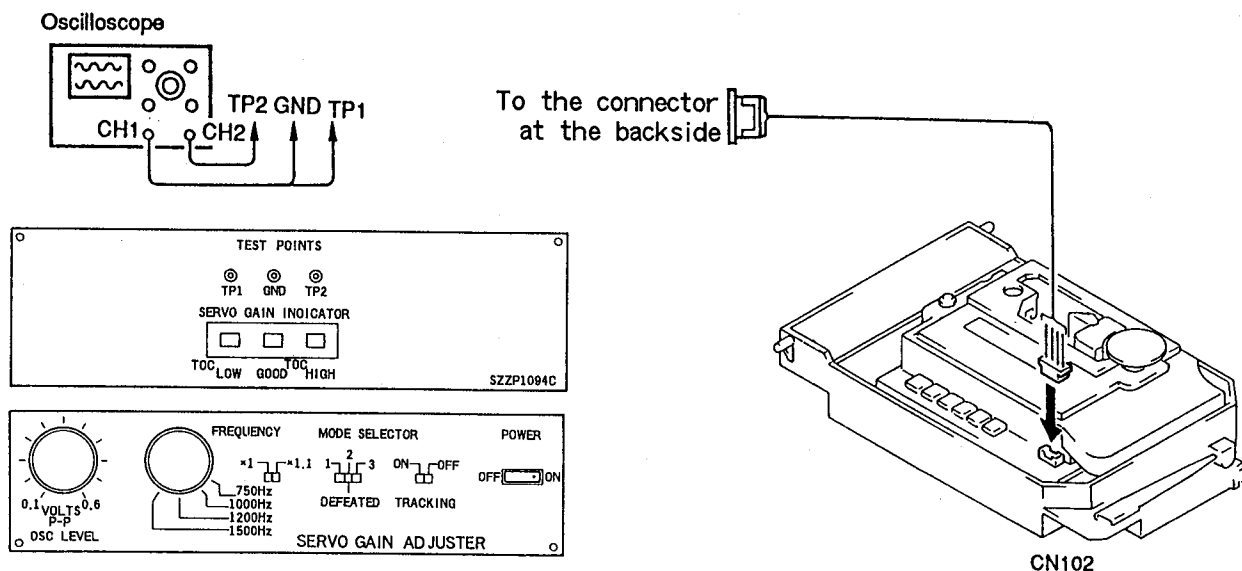

Fig. M

Alignment with Alternate Servo Adjuster.

Equipment and tools used for adjustment

- Servo gain adjuster (See page 20)
- Test disc
(EIAJ CD-1, Philips Test Sample 5A814 126-2, ABEX TCD-731R)
- Commercial music disc
- Dual channel oscilloscope (minimum frequency 30MHz, with EXT trigger and 1:1 probe)
- Low-frequency oscillator
- Hex wrench (M2.0)
- Hex wrench (M1.27)
- Feeler gauge 0.9mm (P/N : RZZ0297)

Steps of Adjustment

The CD changer needs to be adjusted as shown below when the optical pickup, the spindle motor, or the turntable is replaced.

Set Up instructions for Adjustment.

1. Defeat the Disc Detect Sensor by placing none transparent tape over 2 Disc Detect holes in one of the disc trays in Turntable Ref. No. 142. (See Fig. a)

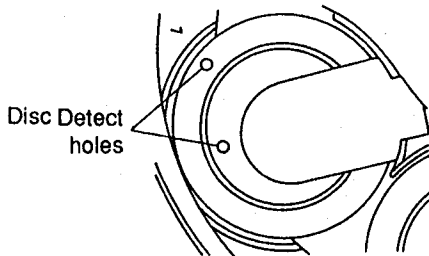

Fig. a

2. Place the unit upside down on small support blocks. (See Fig. b)

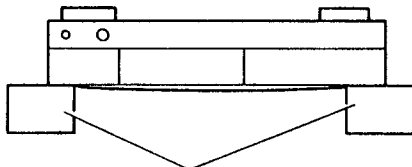

Fig. b

3. Remove bottom cover and remove CD transport. Do not disconnect any wires. (See Fig. c)

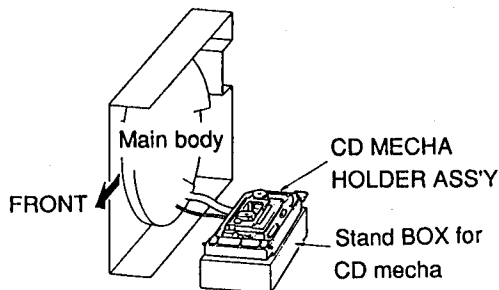

Fig. c

4. Lift stopper ass'y Ref. No. 253 and insert a 13 mm jam between stopper ass'y and chassis. This jam will allow the Turntable to rotate freely. (See Fig. d)

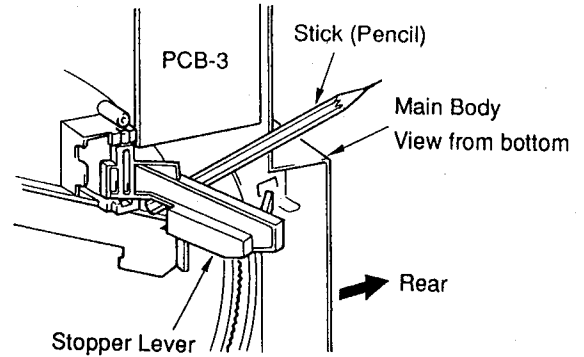

Fig. d

5. Turn on the power switch and wait until the Turntable stops rotating.
6. Place test disc on the disc spindle and hold the disc in place with a round magnet. (See Fig. e)

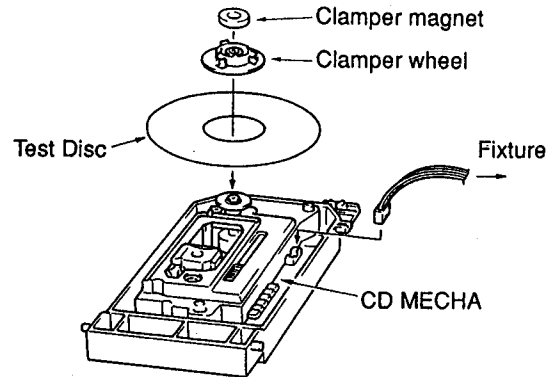

Fig. e

7. Press the Play button on front panel and wait until the Turntable stops rotating.
8. The CD transport is now in the play mode and ready for alignment.

Alignment with Alternate Servo Adjuster.

[1] Turntable height check and adjustment

1. Put a 0.9mm feeler gauge between the turntable and the loading base (see Fig. N).
2. Tighten the turntable retaining screw using a hex wrench (M1.27).
3. Connect CH1 of the oscilloscope across VR104 (FEG) (+) and VR106 (V.REF)(-) of the servo P. C. Board.
Caution: Voltage (2.5V) is present at the V.REF terminal. Be certain that the changer chassis never touches the oscilloscope chassis.
 Oscilloscope setting: VOLT50mV
 SWEEP....1msec.
 INPUT.....DC
4. Set the DC Zero Balance of the oscilloscope.
5. Turn on the power switch, and play a test disc.
6. Check the voltage of the oscilloscope waveform.

Note 1: The turntable height is correct if the measured voltage is $\pm 15mV$. If necessary, fine-adjust the turntable height (tilting the feeler gauge, etc.).
 Over +15mV Decrease the turntable height.
 Over -15mV Increase the turntable height.

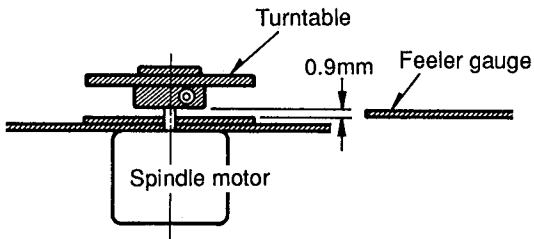

Fig. N

Note 2: If the measured voltage is beyond the range of target voltage even after fine-adjustment described in Note 1, set VR105 to a middle point and check the turntable height again. (In this case, the focus offset needs to adjusted later.)

[2] Pulsation adjustment

1. Connect CH1 of the oscilloscope across TJ101 (+) and TJ102 (-) of the servo P. C. Board.
 Oscilloscope setting: VOLT100mV
 SWEEP....0.5 μ sec.
 INPUT.....AC
2. Turn on the power switch and play the test disc.
3. While playing the test disc, raise the player as shown.
4. Using a hex wrench (M2.0mm), turn the two pulsation adjusting screw alternately to minimize the amplitude fluctuation of the oscilloscope waveform (RF signal).
5. When adjustment is completed, apply liquid bond to fix the adjusting screws.

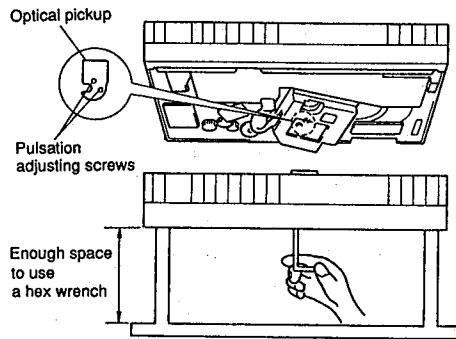

Fig. O

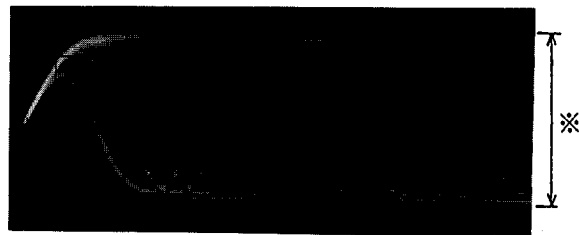

Fig. P

※ Minimize the amplitude fluctuation in this area.

[3] BEST EYE (PD balance) adjustment

1. Connect CH1 of the oscilloscope across TJ101 (+) and TJ102 (-) of the servo P. C. Board.
 Oscilloscope setting: VOLT100mV
 SWEEP....0.5 μ sec.
 INPUT.....AC
2. Turn on the power switch and play the test disc. (Philips Test Sample 5A814 126-2, Scratched) (track number 15)
3. Adjust VR101 to maximize the amplitude of the RF signal eye patterns. (See figure Q.)

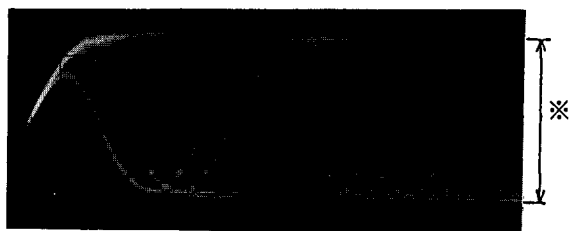

Fig. Q

※ Maximize the amplitude in this area.

Alignment with Alternate Servo Adjuster.

[4] Focus gain adjustment

1. Connect the servo gain adjuster (see figure W).
2. Adjust the low-frequency oscillator to 825Hz (frequency) and 150mVp-p (output level), and connect it to OSC and GND terminals of the servo gain adjuster.
3. Connect CH1 and CH2 of the oscilloscope to TP1 and TP2 of the servo gain adjuster (TP3 is ground).
Oscilloscope setting: VOLT100mV (CH1 and CH2)
SWEEP....0.5msec.
INPUT.....AC
4. Play a test disc. (EIAJ CD-1)
5. Adjust VR104 to equalize the amplitude in CH1 and CH2.

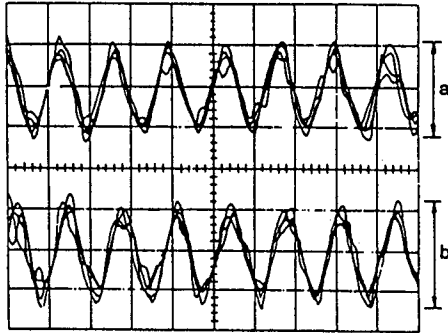

Fig. R

※ Adjust until a equals to b.

[5] Tracking gain adjustment

1. Adjust the low-frequency oscillator to 1.1kHz (frequency) and 150mVp-p (output level), and connect it to OSC and GND terminals of the servo gain adjuster.
2. Connect the servo gain adjuster (see figure X).
3. Turn on the power switch and play a test disc. (EIAJ CD-1)
4. Adjust VR102 to equalize the amplitude in CH1 and CH2.

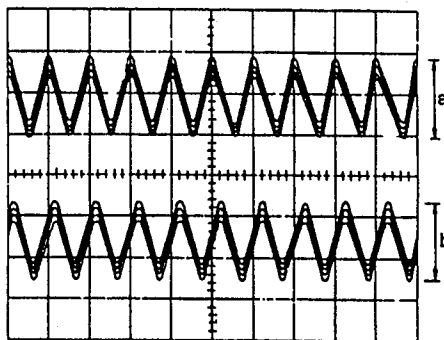

Fig. S

※ Adjust until a equals to b.

[6] Focus offset adjustment

1. Connect CH1 of the oscilloscope to TJ101 (+) and TJ102 (-) of the servo P. C. Board; connect CH2 to VR104 (FEG) (+).
Oscilloscope setting: VOLT100mV (CH1 and CH2)
SWEEP....0.5msec.
INPUT.....AC (CH1 and CH2)
MODE.....NORM (CH1 trigger)

2. Play track number 6 of the EIAJ CD-1 test disc with a 0.6mm width of tape.

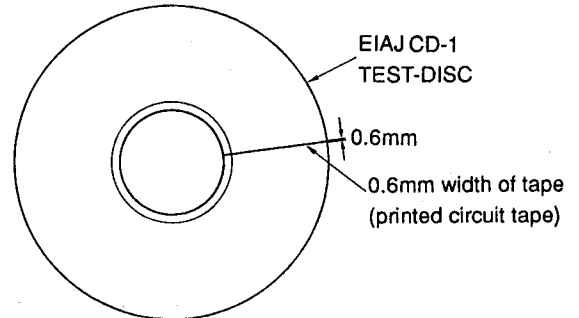

3. Trigger the oscilloscope to get the waveforms shown below. Then adjust VR105 so that the RF dimple in CH1 is smoothly enveloped and the amplitude of CH2 is minimized, or so that A equals to B.

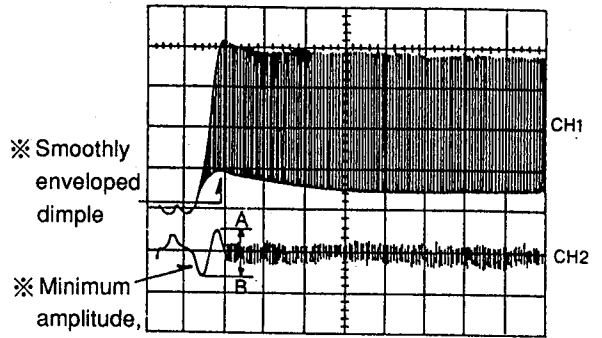

Fig. T

[7] Tracking offset adjustment

1. Connect CH1 of the oscilloscope to TJ101 (+) and TJ102 (-) of the servo P. C. Board; connect CH2 to VR102 (TEG) (+).
Oscilloscope setting: VOLT100mV (CH1 and CH2)
SWEEP....0.5msec.
INPUT.....AC (CH1 and CH2)
MODE.....NORM (CH1 trigger)
2. Turn on the power switch and play the test disc. (EIAJ CD-1 with putting a 0.6mm width of tape, track number 6)
3. Trigger the oscilloscope to get the waveforms shown below. Then adjust VR103 so that the RF dimple in CH1 is smoothly enveloped and the amplitude of CH2 is minimized, or so that A equals to B.

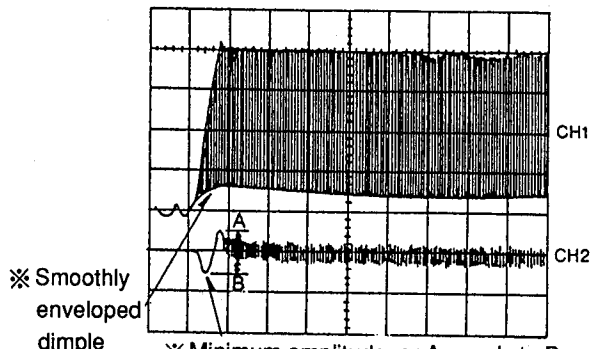

Fig. U

Alignment with Alternate Servo Adjuster.

[8] Tracking balance adjustment

1. Connect the servo gain adjuster (see figure X).
2. Adjust the low-frequency oscillator to 1.1kHz (frequency) and 600mVp-p (output level), and connect it to OSC and GND terminals of the servo gain adjuster.
3. Connect CH1 of the oscilloscope to TJ101 (+) and TJ102 (-) of the servo P. C. Board; connect CH2 to OSC of the servo gain adjuster.

Oscilloscope setting: VOLT100mV (CH1)
 SWEEP....1msec.
 INPUT.....AC (CH1 and CH2)
 MODE.....NORM (CH2 trigger)

4. Turn on the power switch and play a test disc. (EIAJ CD-1)
5. Adjust VR106 to get the waveforms for CH1 output as shown below (minimum jitter).

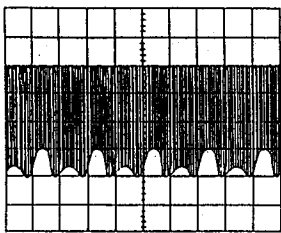

Fig. V

* Align for minimum jitter.

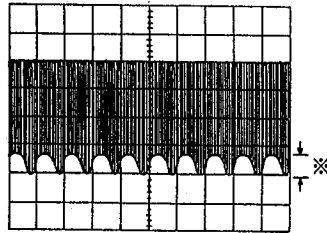

Fig. V1

* Minimum jitter.

[9] Play confirmation after adjustment

• **Skip search confirmation**

1. Play a commercial music disc.
2. Operate the skip button to check the skip search function (forward and reverse).

• **Manual search confirmation**

1. Play a commercial music disc.
2. Push the manual search button to check smooth manual search operation at low and high speeds (forward and reverse).

• **Defect check**

1. Play the test disc. (ABEX Vertical Deviation Test Disc TCD-731R, track number 1)
2. Play the middle sections of Vertical Deviation test disc and check the player operation for track jumping and noise.

Connections for Focus Gain alignment

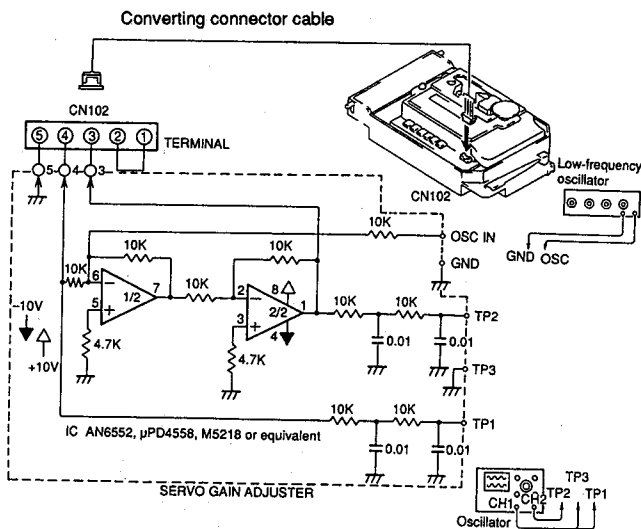

Fig. W

Connections for Tracking Balance alignment

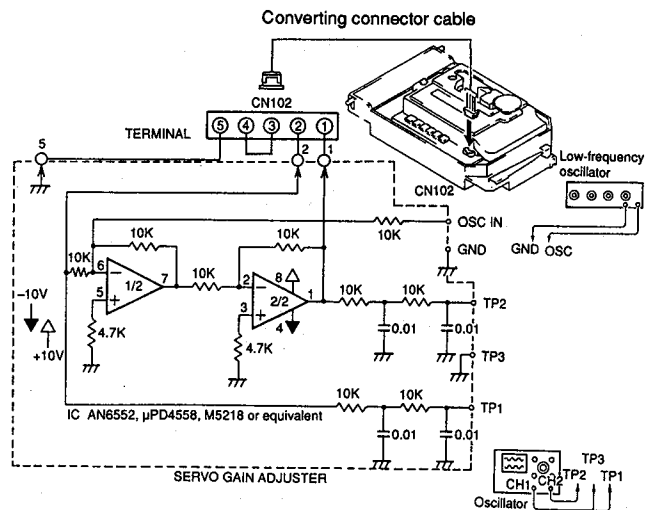

Fig. X

CIRCUIT DESCRIPTION

1. APC CIRCUIT

A semiconductor laser is used as the light source for the optical pickup. As the output from the semiconductor laser changes radically with changes in temperature, a circuit must be provided to stabilize this output. For this purpose, a monitor diode which detects the optical output of the laser diode is used in the semiconductor laser.

As the laser diode emits light from its bonded surface, light is emitted both in front and behind. The light emitted behind is monitored with the monitor diode installed on its rear surface, and the optical output is thus controlled. The light emitted in front becomes the light source for the pickup.

Fig. 1 shows the APC circuit.

When the temperature rises and the optical output decreases, the monitor diode current (IS) decreases, the electric potential of IC101 pin 7 rises, the base current of the driving transistor increases, and the laser diode current increases. This causes the reduced optical output to return to its former level.

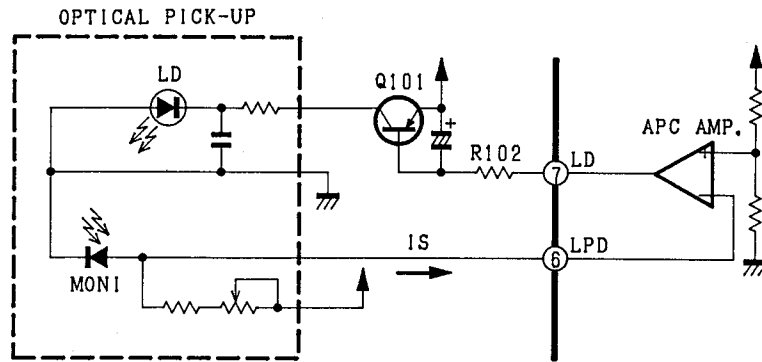

Fig. 1

2. FOCUS SERVO

2-1 Optical pickup

This set employs a one-beam optical pickup comprised of four division photodiodes, A through D as shown in Fig. 2. The four photodiodes (A through D) at the center provide focus error detection by using their property to allow the beam to focus into a round image only at a certain point.

The sums of outputs from diagonal two elements of four division photodiodes (A+C and B+D) are compared by the differential amplifier in IC101 to detect the shape of the beam image.

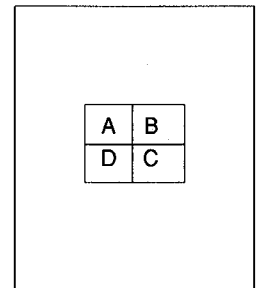

Fig. 2

2-2. Focus error detecting operation

The reflected laser beam from a disc is polarized 90° with the half mirror and sent to the concave lens. The beam passed through this concave lens is then sent to the four division photodiodes and focuses into an image whose shape varies with the distance between the disc and the objective lens. Such change in the beam shape causes the current flowing from the photodiodes to vary.

Shown in Fig. 3 is the principle of the focus error detection.

The currents from the photodiodes (A+C and B+D) are applied to pins 7 and 8 of IC101 and converted to voltage by RF I-V amplifiers (1) and (2) included in IC101.

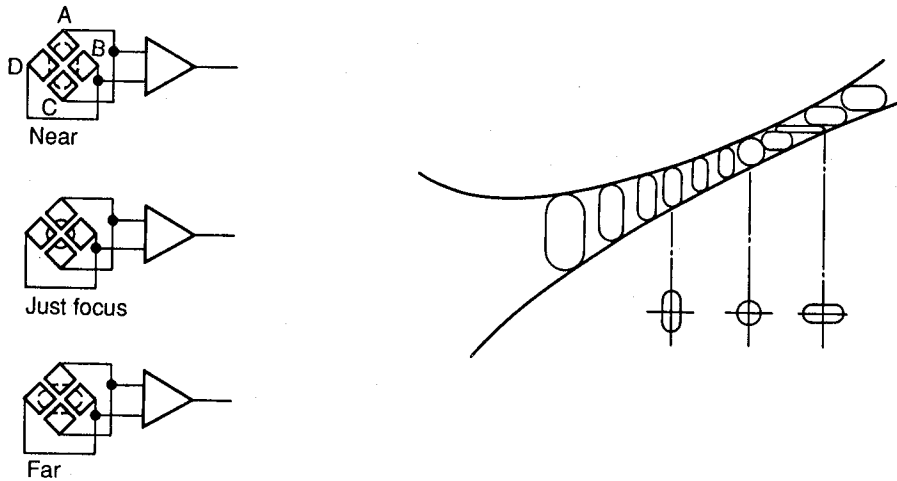

Fig. 3

2-3. Focus servo control operation

The focus error signal, after being converted to voltage by the RF I-V amplifier, is transmitted to the operation amplifier in the IC and output from pin 15.

When the disc to objective lens distance is in just focus, the beam forms a true round. In this state, the beams applied to four elements of four division photodiodes becomes equal and thus the output provided then is 0 (zero). When the disc to objective lens distance is too close (near focus), the beam is reflected divergently to form an oval in crosswise direction. In this state, the outputs provided from photodiodes A and C are higher than those from B and D, resulting in negative (-) output voltage. On the other hand, when the distance is too far (far focus), the beam is reflected convergently to form an oval in longitudinal direction. Then the outputs from photodiodes B and D are higher, resulting in positive (+) output.

The output voltage (focus error signal) from pin 15 of IC101 passes through IC102, in from pin 8 and out from pin 9, and IC103, in from pin 6 out from pin 12 as shown in Fig. 4. It is amplified in each IC and fed to the focus coil which then drives the objective lens of the pickup.

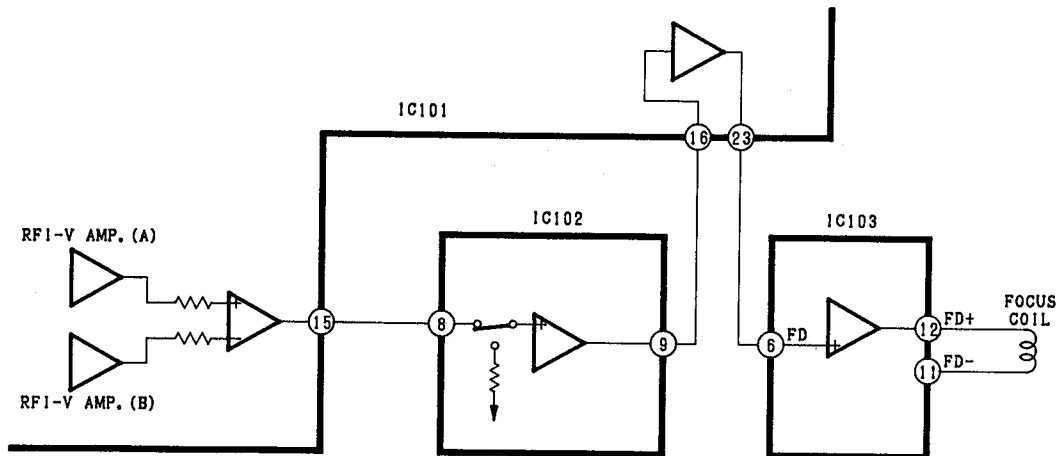
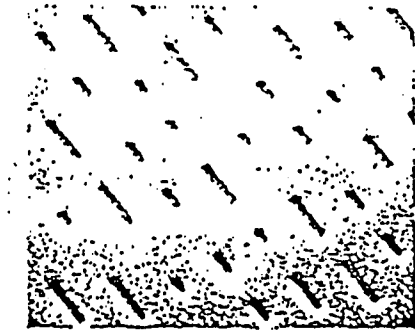

Fig. 4

2-4. CD Tracking Requirements

The Compact Disc does not have grooves like an ordinary phonograph record. Instead, its information is contained in the pattern of indentations called "pits" that run in a spiral "track" from the inside to the outer edge of the disc. The information is read by detecting the presence and absence of pits using laser beam light reflected off the pit area. Since there is no physical contact, a sophisticated detection and servo system must be used to keep the laser beam focused on the pit track. It is this "tracking system" that will be discussed in these pages.



Pits on a CD.

Fig.5

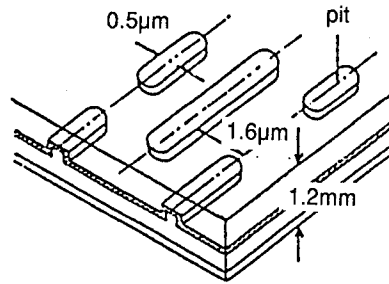

Fig.6

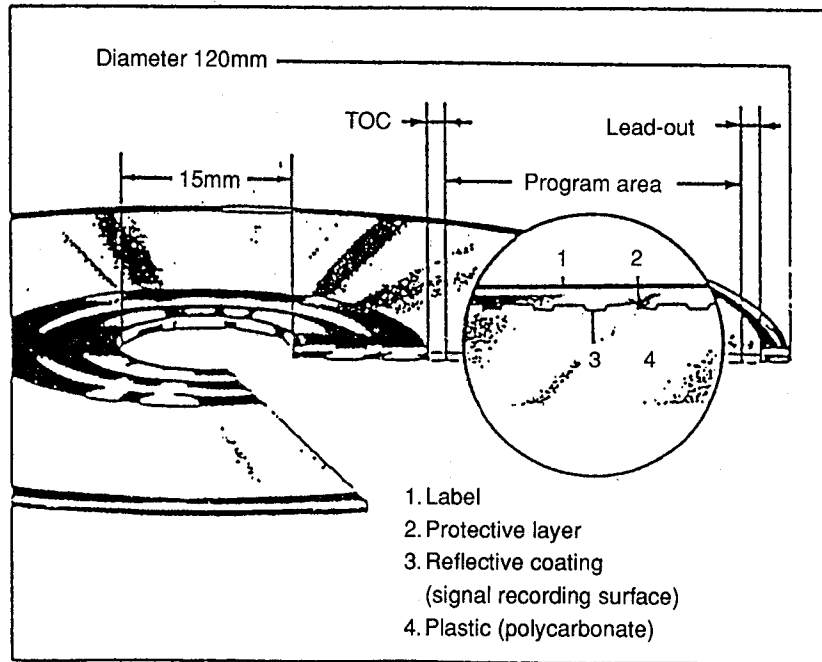

Fig.7

2-5. Precision Required for Tracking

The pit tracks are extremely narrow and close together. If a CD was magnified to the size of a baseball field, the pit tracks would be about 1.6mm apart. The tracking system must be able to keep the laser beam on the correct track in this microscopic world even when matters are complicated by external vibrations, scratches, fingerprints, and so on.

Certainly the method of detecting the pit track is basic to a tracking servo system. But specialized servo technology, lens drive technology, and chassis construction technology also help determine the system's ability to overcome obstacles such as disc defects, fingerprints, and vibrations.

Outstanding "playability" has been achieved in CD changer by just such a blend of technologies. One could call it a crystallization of the development and manufacturing know-how gained from experience.

• 1-Beam methods

1-beam optical pickup construction

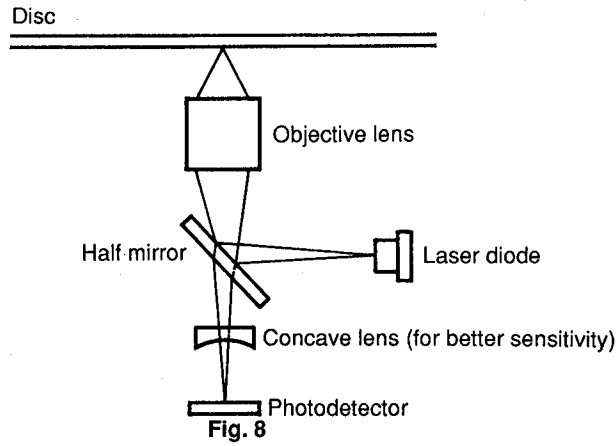

Principle of time difference detection method of single-beam tracking

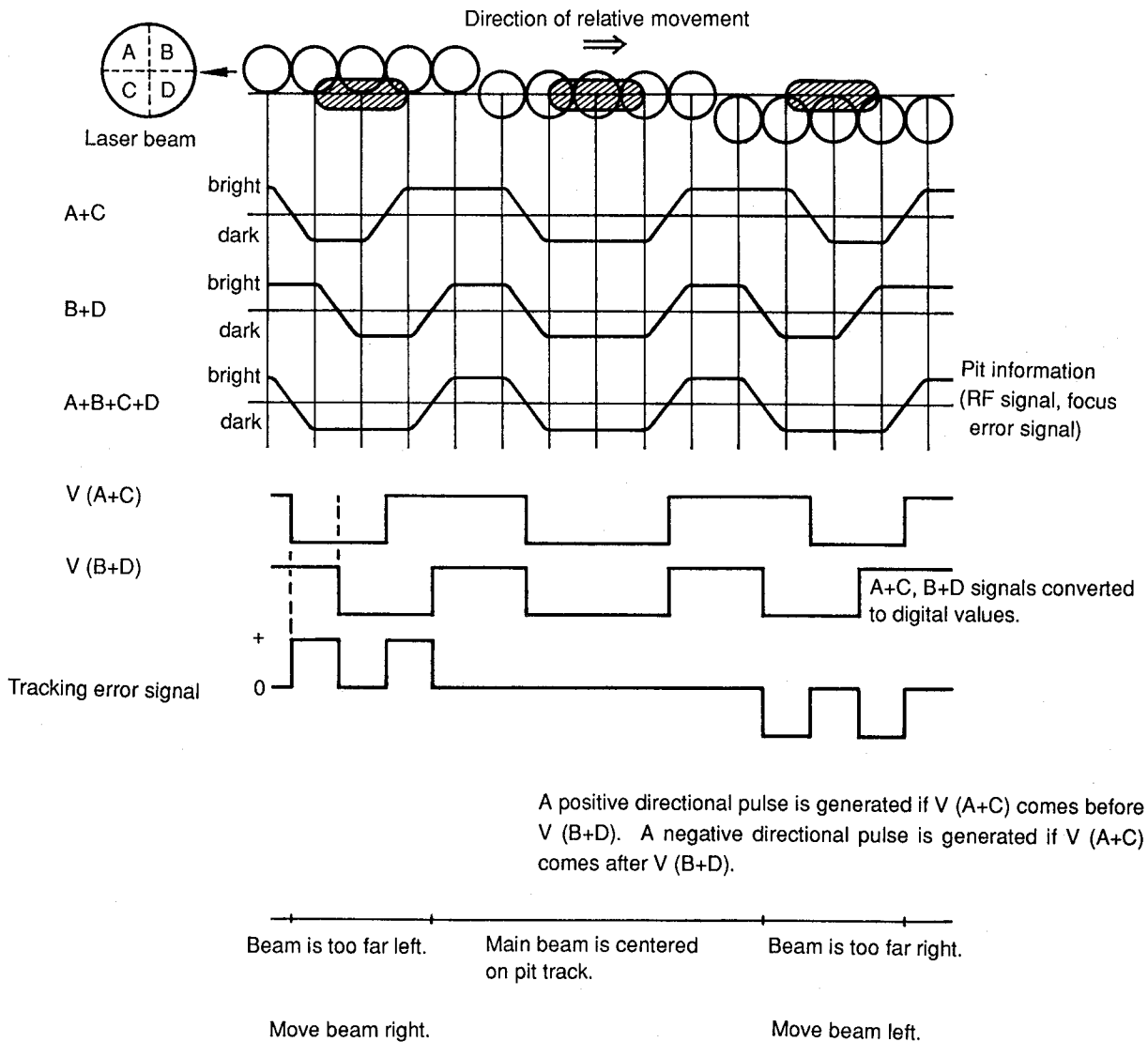

Fig. 9

2-6. Tracking servo control operation

When a tracking error signal is detected by photodiodes A through D, it is fed to pins 2 through 5 of IC101 respectively as shown in Fig. 10. In IC101, the signal is converted into voltage by the I-V amplifier, transmitted to the tracking error amplifier and output through pin 13 and 14.

While it passes through IC102, in from pin 1 and 2 and out from pin 6 and IC101, in from pin 17 and out from pin 22, and IC103, in from pin 7 and out from 9 and 10, it is amplified in each IC and sent to the tracking coil to adjust pickup so that the amount of track shift is reduced as closely to none as possible.

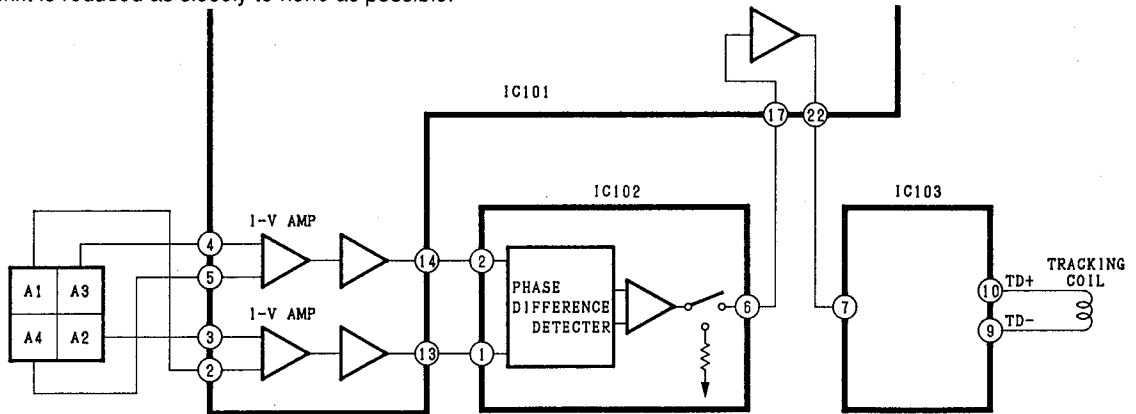

Fig. 10

3. REGENERATIVE CIRCUIT

3-1. RF circuit

RF signal from optical pickup are applied to pin 1 of IC101 and amplified, and out from pin 40.

While it passes through IC101, in from pin 39 and out from pin 35, and IC102 in from pin 12 and out from pin 21, it is amplified in each IC and sent to the Digital Signal Processor IC201.

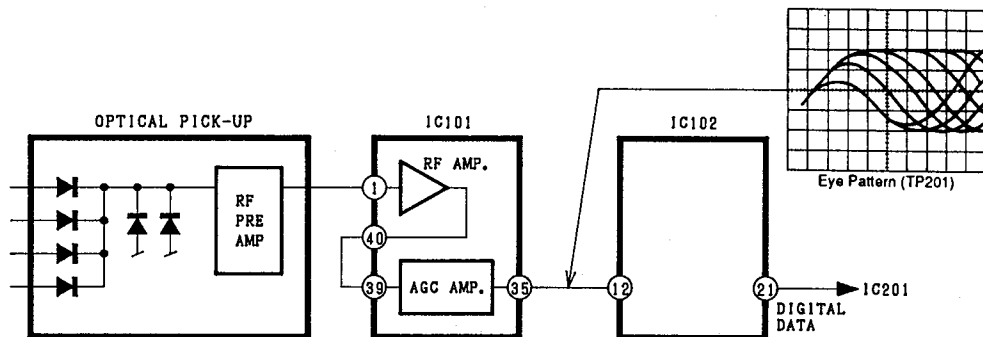

Fig. 11

3-2. EFM demodulation, error correction, serial/parallel conversion

EFM demodulation, error correction and serial/parallel conversion are performed by the internal circuitry of IC201. The digital signal from pin 21 of IC102 are sent to pin 3 of IC201, then demodulated from 14 bits to 8 bits by EFM readjustment. At the same time any error, if found, is corrected (CIRC) and the signals are sent to the D/A converter interface. After that, they are output as 18-bit digital signals from pins 26, 27 and 28 of IC201 and fed to the D/A converter of IC701.

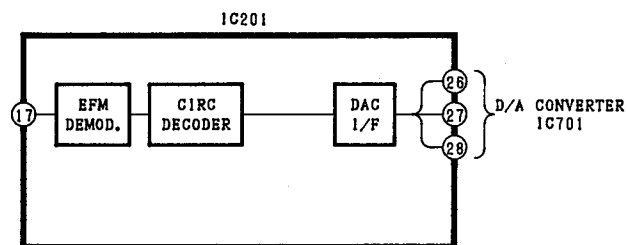

Fig. 12

3. 1-bit D/A Converter

Conventionally, high-precision D/A conversion was mainly carried out using resistor ladder systems. There was, however, one main drawback with these systems, which was that zero cross distortion was likely to be generated. To achieve production of a high-precision D/A converter with a minimum amount of zero cross distortion, it would be necessary to carry out complicated and bothersome processes such as laser trimming processing. In addition, use of such D/A converter would require a sampling-and-hold circuits(or de-glitcher circuit) and an intricate analog filter with special characteristics when mounting it. To solve these difficulties, we used a 1-bit D/A converter with 3rd order noise shaping technology (IC701: MN 6471M).

3-1. Features and Configuration of MN6471M

- Features
1. No zero cross distortion
 2. No non linear distortion
 3. Built-in 4 times oversampling digital filter
 4. 2 channels (left and right) built in
 5. 4DAC configuration possible
 6. Single 5V power supply operation

The block diagram is shown in Fig. 13. The MN6471M is configured of a digital filter, a 3rd order noise shaping circuit, and a PWM.

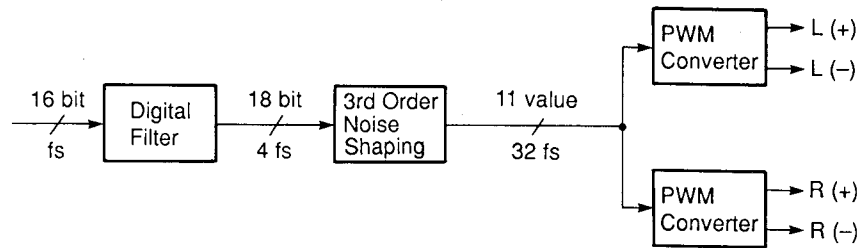

Fig. 13

3-2. Configuration of MN6471M

Fig. 14 shows the configuration of the MN6471. The sampling frequency of the input data is expressed in fs, so the 3rd order noise shaping circuit operates at 32fs. This means that a 32-times oversampling filter is required. In this LSI, however, oversampling is carried out first at 4fs in the first digital filter, and following that, a 0 order hold takes place in the 3rd order noise shaping circuit. This enables conversion of the 4fs signal to a 32fs signal.

The digital filter, using 384fs as clock signals, and the noise shaping section, uses 64fs, carry out time division processing on the data for the left and right channels. The PWM section, using 768fs as a clock signal, carries out signal processing for the left and right channels independently.

In the noise shaping section, the 19-bit 32fs signal is converted to 11 values and pulse width modulation (PWM) is carried out on these signals in the PWM section. D/A conversion is carried out in this way.

Following are the descriptions of the various blocks.

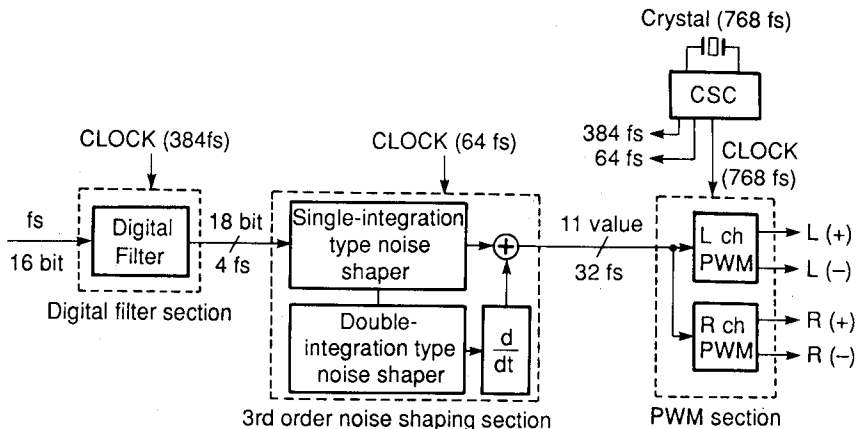

Fig. 14

4. Digital filter

Fig. 15 shows the signal data of an audio signal up to 20kHz that has been digitalized, along with the frequency distribution of the signal data. The graphs show the conditions for a sampling frequency of 44.1kHz, plus its doubled frequency, 88.2kHz, and its quadrupled frequency, 176.4kHz.

As the figure shows, for the same signal up to 20kHz, the noise portion of the digitalized signal component tends to shift toward the higher range of the signal if the sampling frequency is increased. However, at any sampling frequency, the volume of necessary audio signal information remains constant up to 20kHz. This allows certain important results to be derived; that is, if the information represented in section (a) is obtained, then it should be possible to create a signal in the form shown in (b) or (c).

When the noise caused by sampling shifts to the higher frequency range, as shown in (b) or (c), the low pass filter characteristic to eliminate noise during re-conversion to an audio signal need not be steep but can be rather gradual as shown. It is comparatively simple to provide a high audio quality low pass filter of such characteristic with little phase fluctuation or distortion.

The question now becomes how to make a signal sampled at 44.1kHz resemble one sampled at a much higher frequency. Fig. 16 shows the signal sequence sampled at the same 44.1kHz as in Fig. 15 and its frequency distribution.

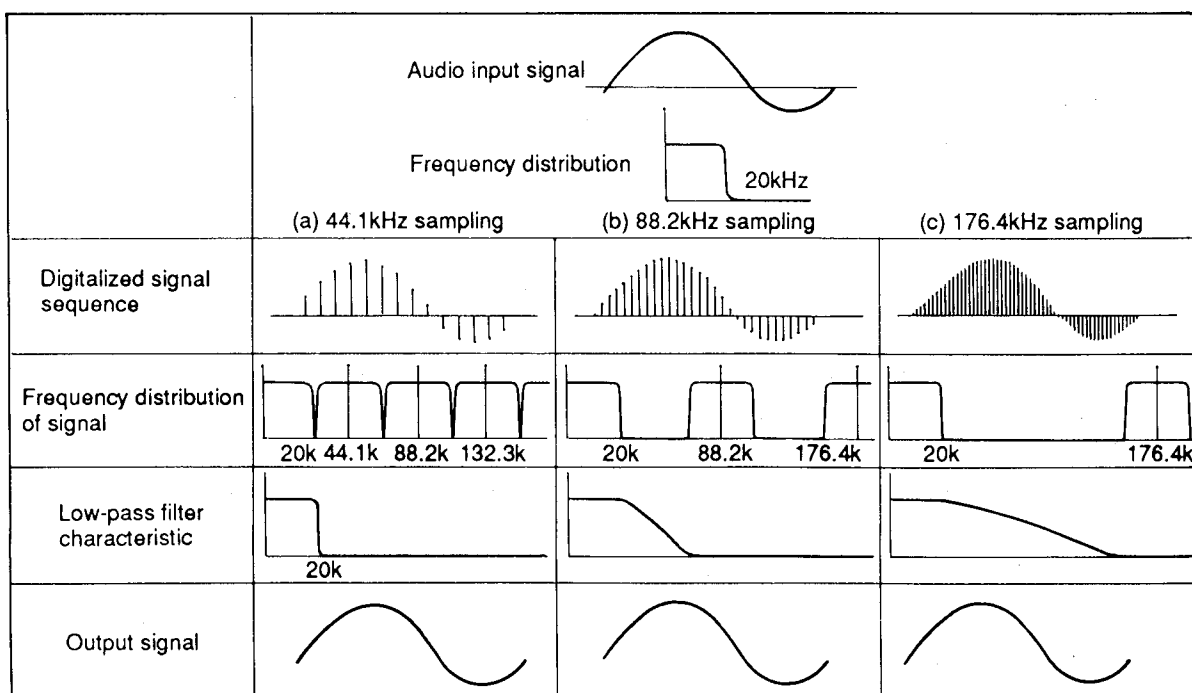

Fig. 15

If the frequency is to be doubled as the first step in increasing the sampling frequency of the signal, zero-level data is added between the data marked with X in Fig. 16(b). In the original signal sequence sampled at 44.1kHz, there are data only at the points of the sampling timing, while the intervals between those points have all been made zero-level. Introducing zero data in these intervals does not change the original data in any way, nor is the frequency distribution altered. Only the sampling frequency is doubled.

Passing this data in its modified form through a digital filter with the characteristic shown in Fig.16(c) causes the portion corresponding to N1 to be eliminated, resulting in a signal sequence with the frequency distribution shown in Fig.16 (d). This signal sequence possesses exactly the same shape as that obtained for the signal in Fig. 15(b), sampled at 88.2kHz.

In other words, this method enables the sampling frequency to be doubled.

The digital filter used in this unit is a Finite Impulse Response type. Its circuit diagram is shown in Fig. 17.

The sampling frequency of this unit has been quadrupled, and the phase characteristic has been improved by using a softer analog low-pass filter.

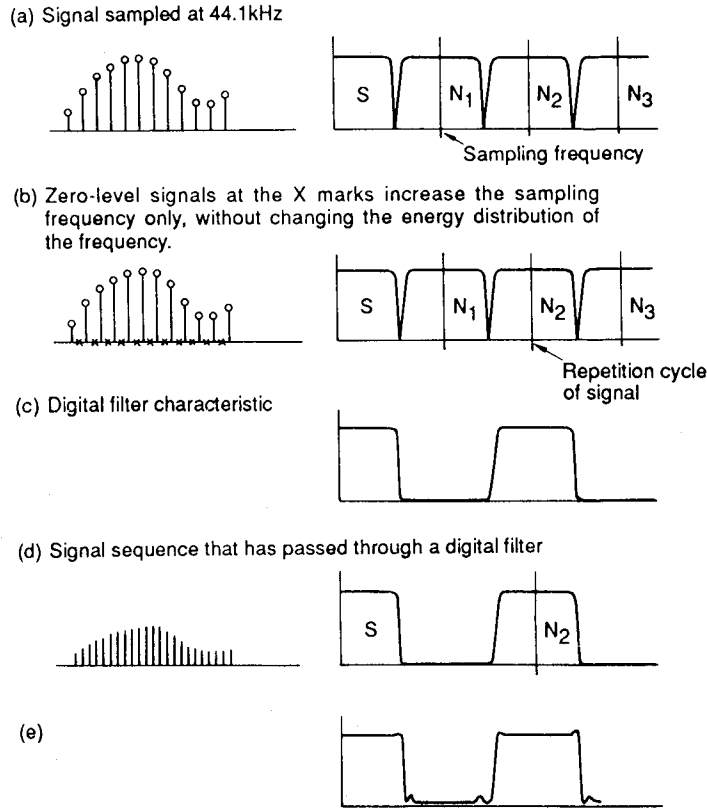

Fig. 16

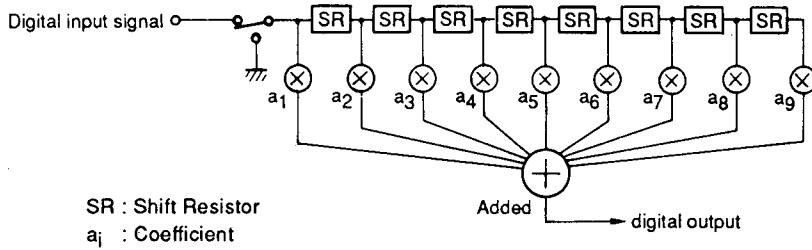

Fig. 17

5. Noise shaper

a) Single-integration noise shaper

The block diagram is shown in Fig. 18.

According to the figure, the relation between input X and output Y is as follows:

$$Y = X + (1 - Z^{-1}) Vq \dots\dots\dots (1)$$

The quantization error Vq is a random value, and $(1-Z^{-1})$ expresses the differential characteristic. Thus, according to equation (1), the spectrum of the quantization error Vq for the single-integration noise shaper has a characteristic of 6dB/oct, and the lower the frequency is, the greater the attenuation becomes. (This is because the noise distribution can be changed by the noise shaper).

b) Double-integration noise shaper

The block diagram is shown in Fig. 19.

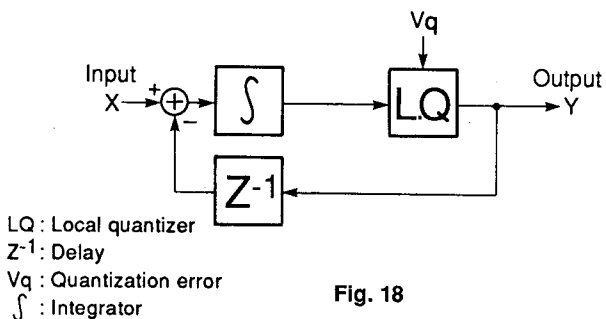

Fig. 18

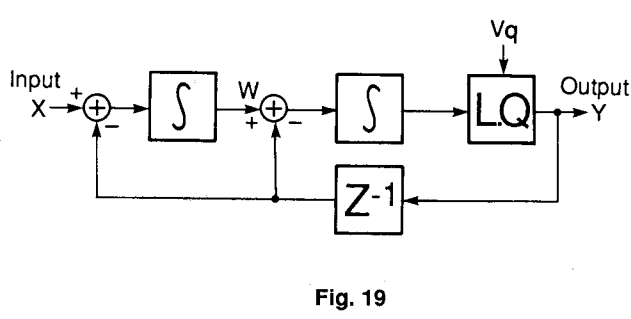

Fig. 19

In Fig. 19, the path to the output seen from W has a configuration identical to that of the single-integration noise shaper, so that relation between W and Y is:

$$Y = W + (1 - Z^{-1}) Vq \dots\dots\dots (2)$$

The relation between X and Y is:

$$W = \frac{1}{1 - Z^{-1}}(X - Z^{-1}Y) \dots\dots\dots (3)$$

And the result obtained from above equations (2) and (3) is:

$$Y = X + (1 - Z^{-1})^2 Vq \dots\dots\dots (4)$$

Comparison with equation (1) shows that the term $(1 - Z^{-1})$ is a square of itself. In other words, with the double-integration noise shaper, the spectrum of the quantization error Vq is attenuated at a slope of 12dB/oct.

Fig. 20 shows the output spectrum of the noise shaper.

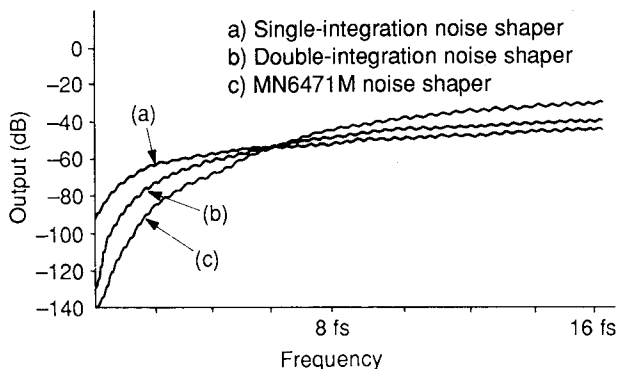

Fig. 20

5-2. 3rd order noise shaper

The block diagram of the 3rd order noise shaper is shown in Fig. 21.

This configuration shows that the first stage uses a single-integration noise shaper and the following stage uses a double-integration noise shaper. The quantization error of the first stage is input at the second stage.

In this configuration, single-integration and double-integration noise shapers are connected at several stages, and the quantization error of the previous stage is quantified again at the following stage, so that the quantization error included in the output of the previous stage is negated. In this way, compensation is carried out.

In this noise shaping circuit, the input is expressed as X, the output as Y, and the re-quantized error as Vq , and their relation for each order is shown in the following equations.

- (1st order) $Y = X + (1 - Z^{-1}) Vq$
- (2nd order) $Y = X + (1 - Z^{-1})^2 Vq$
- (3rd order) $Y = X + (1 - Z^{-1})^3 Vq$

In noise shaping, as the order of the transfer coefficient called $(1 - Z^{-1})$ becomes larger, the noise in the 1/2 fs audio band moves higher in the frequency range. The result is that, within a narrow audio band, an 18-bit performance can be obtained even from a 1-bit DAC.

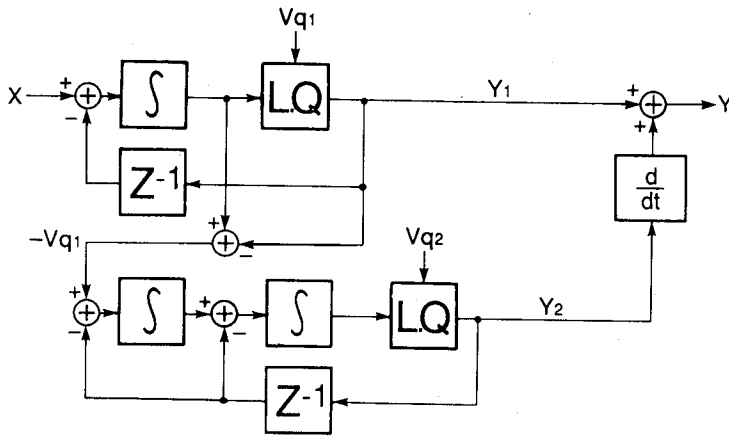

Fig. 21

$$Y_1 = X + (1 - Z^{-1}) V_{q1} \dots\dots\dots (5)$$

$$Y_2 = -V_{q1} + (1 - Z^{-1})^2 V_{q2} \dots\dots\dots (6)$$

$$Y = Y_1 + (1 - Z^{-1}) Y_2 \dots\dots\dots (7)$$

The result obtained from above equations (5) ~ (7) is:

$$Y = X + (1 - Z^{-1})^3 V_{q2} \dots\dots\dots (8)$$

6. PWM Output Section

In the output from the MN6471M noise shaper, the 11 value data of the 32fs is output. In the PWM section, pulse width modulation (PWM) is carried out on that signal, enabling D/A conversion. Fig. 22 shows the PWM section of the MN6471M.

The 11 value digital data output from the noise shaper is converted (1-bit data stream) to pulse signal with 11 pulse widths precisely controlled by the crystal OSC and output as an analog signal. In the PWM output section, signals from both left and right channels are output as differential output so that the synchronous-phase noise is eliminated and the 2nd order high-frequency distortion is reduced.

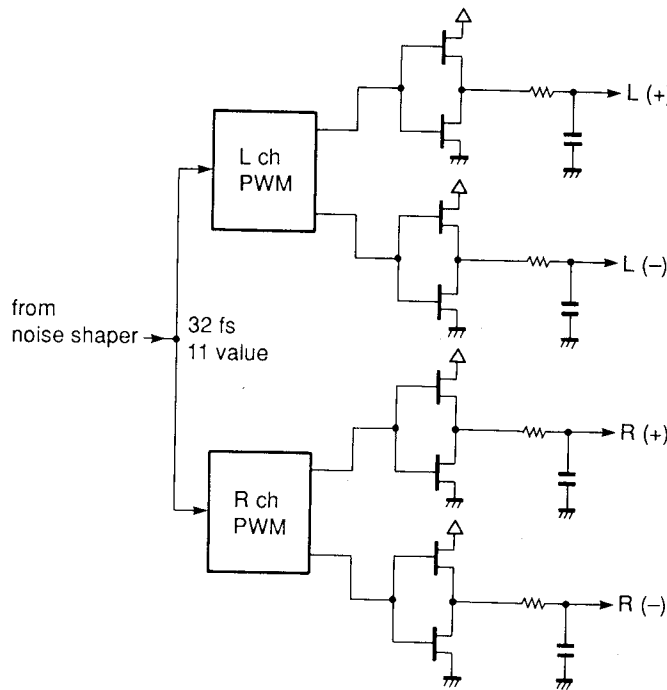

Fig. 22

7. Audio Circuit

Fig. 23 shows a block diagram of the audio circuit.

The outputs from Pin 14 (OUT L (+)) and Pin 11 OUT (-) pass through the 2-step LPF which consists of C601, R601 and R603 for one and C603, and R607 for the other, and the high frequency component of the PWM output from DAC is removed. Then the (+) side component of the PWM is inputted directly, and its (-) side component through the inverted darlington buffer circuit consisting of Q301 and Q303 to the discrete circuit amplifier consisting of Q305, Q307, Q309 and Q311, where they are synthesized into an approximately 2V signal voltage which is then output to the LPF circuit of the next stage.

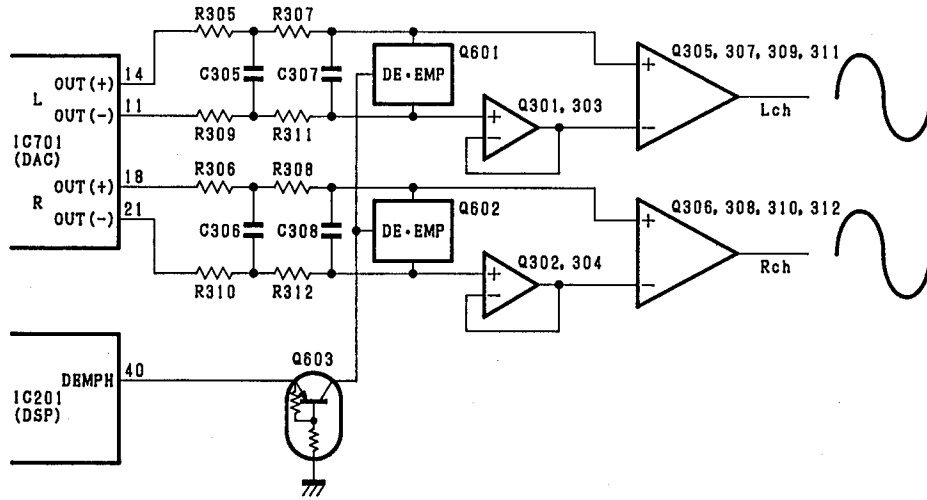

Fig. 23

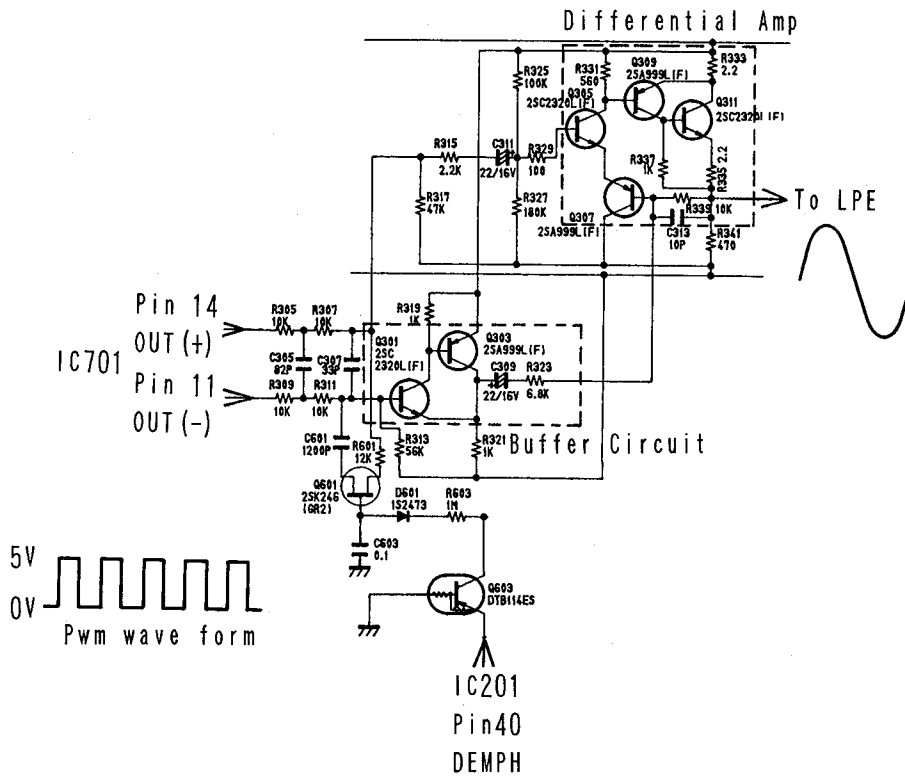

Fig. 24

The emphasis data from the disc is output through the terminal (Pin 40) of IC201. When a disc to which emphasis is applied is playback, this terminal is set high and Q603 turns ON. Following this, Q601 is also turned ON. Then connected C601 and R601 provide the DE-Emphasis characteristics. Fig. 24 shows the buffer circuit and the differential amplifier. (Light channel only)

8. Low-pass filter

Fig. 25 shows a final-stage circuit which includes a low-pass filter and other elements.

The portion of Fig. 25 enclosed by the broken line is 3rd-order active LPF. This LPF causes noise in the high range to be cut. Q313 and Q315 (Left channel) and Q314 and Q316 (Right channel) are buffer circuit of inverted darlington configuration. Q317 and Q318 are FET controlled constant current circuits. Q50 and Q51 are power muting circuit.

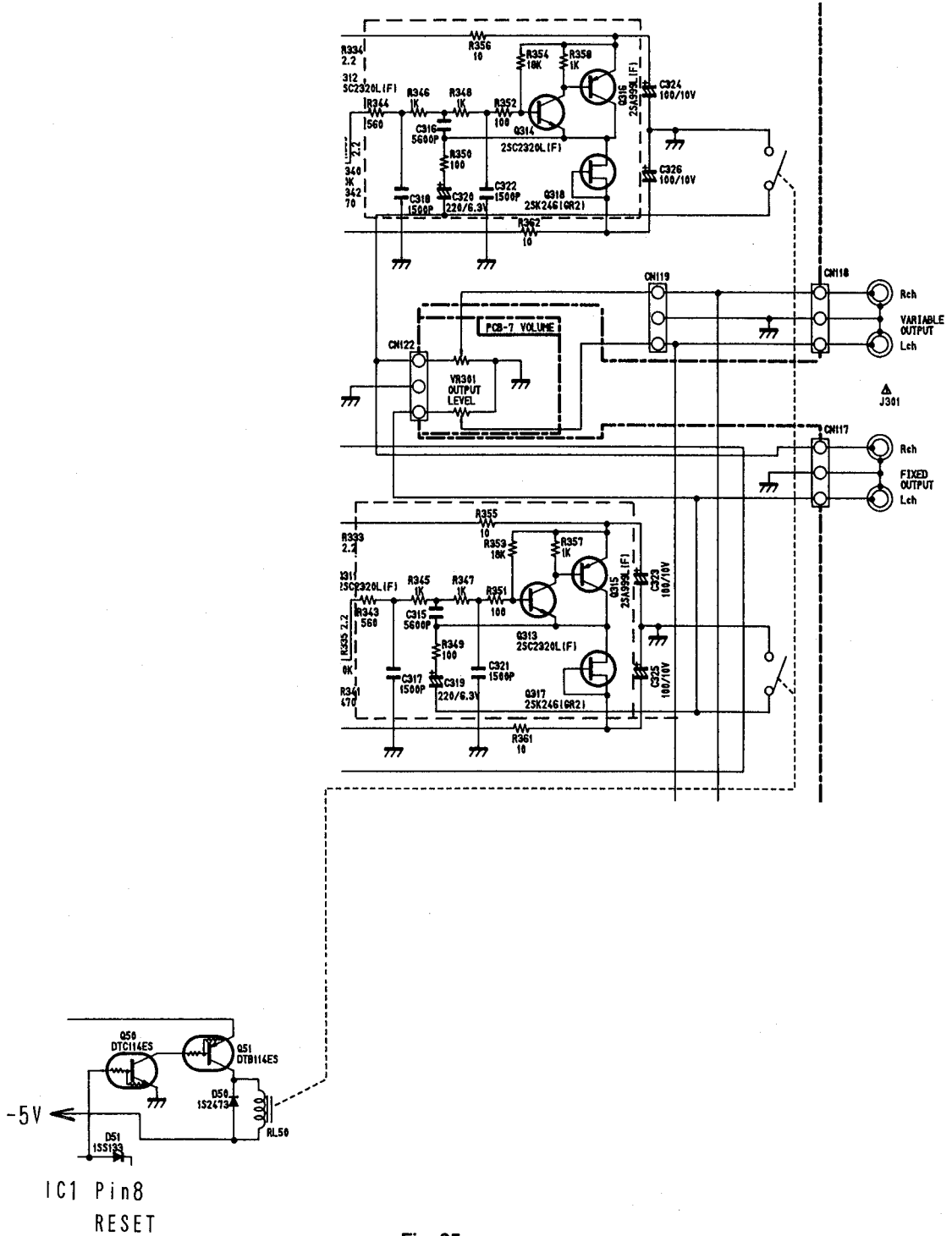
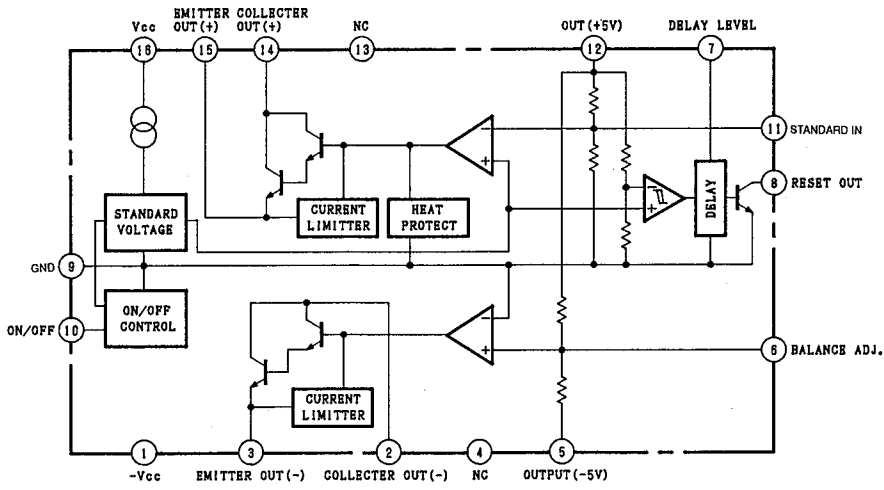

Fig. 25

IC BLOCK DIAGRAM

IC1: M5290P
Voltage Regulator



IC101, 501: NJM4565D
OP-Amp., Headphones Amp.

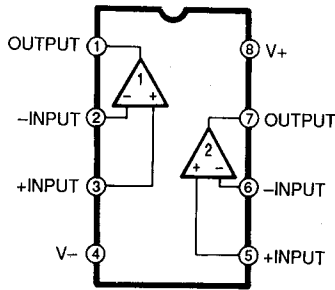

IC102: BA6247N
Reversible Motor Driver

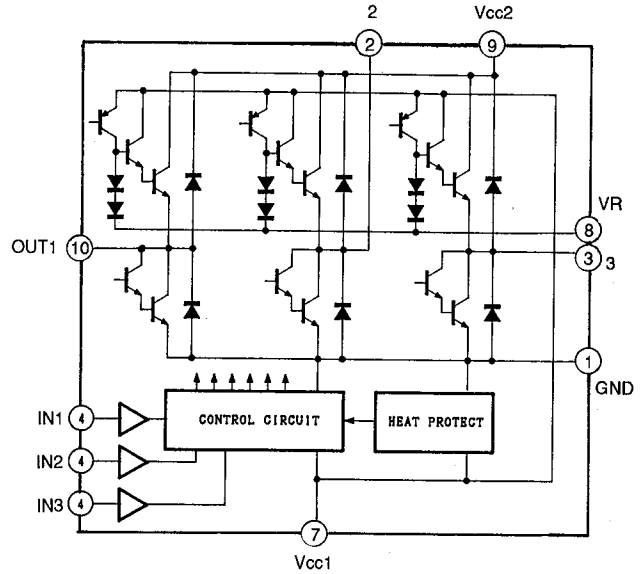

IC103: LA6515
Power OP-Amp.

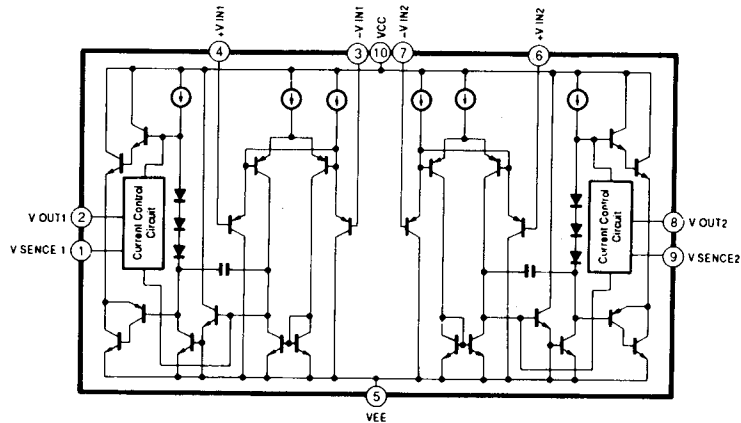

IC201: MN6626
Digital Signal Processor

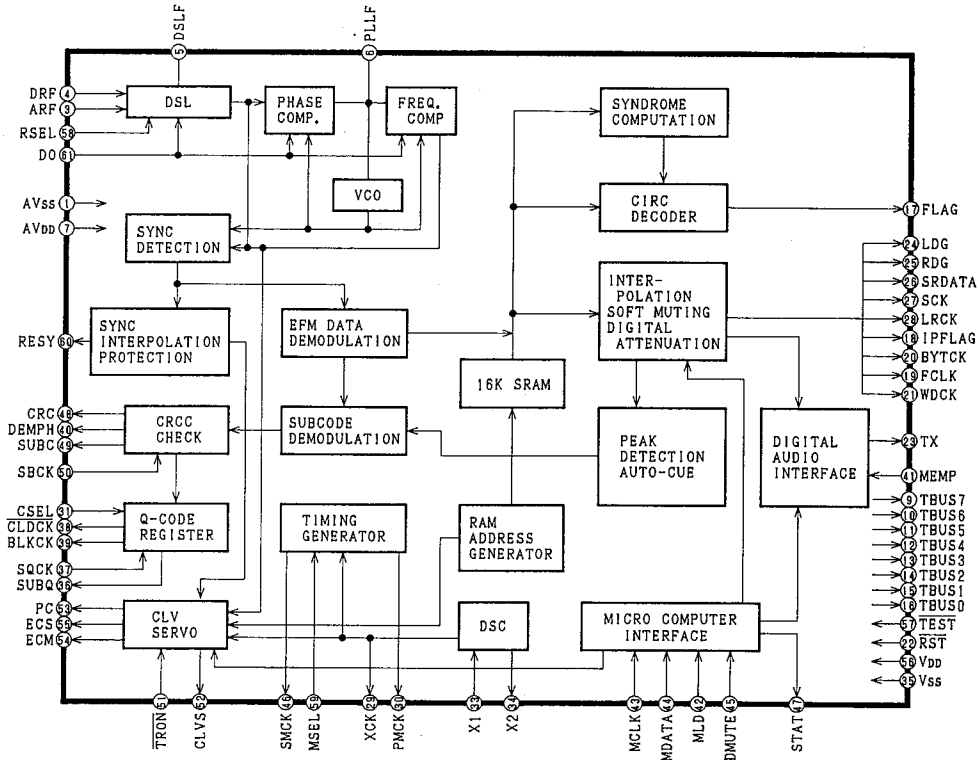

IC401: MN187124L
Microcomputer, System Control and FL Drive

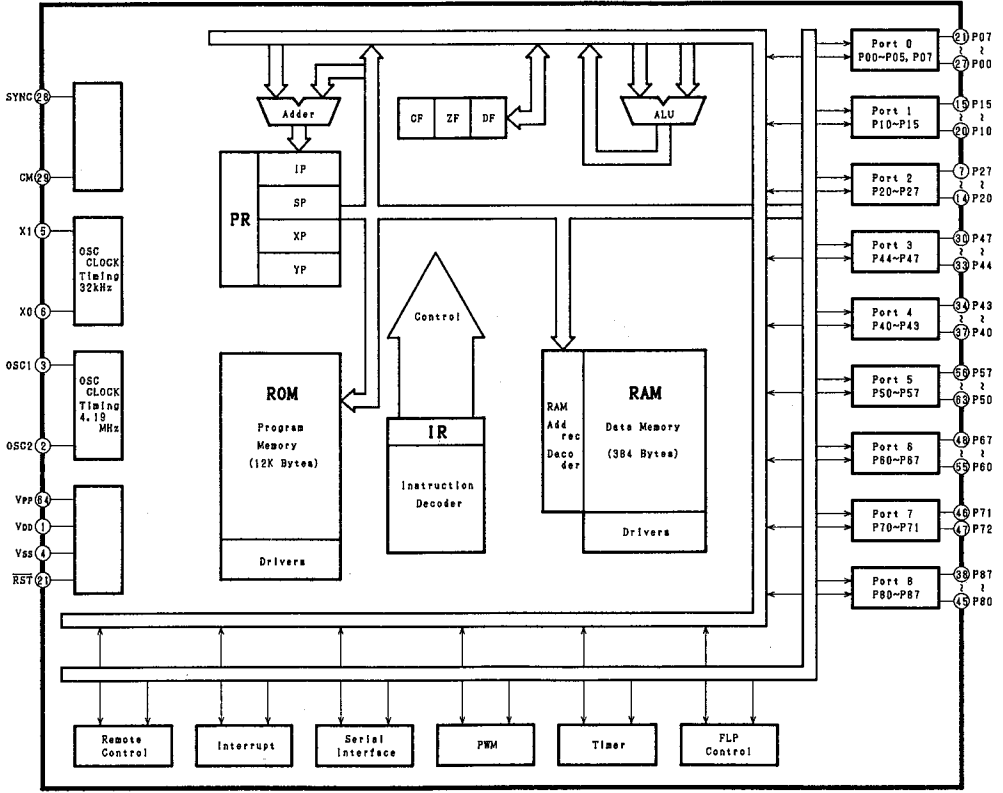

IC402: T74HC04F
Hex Inverter

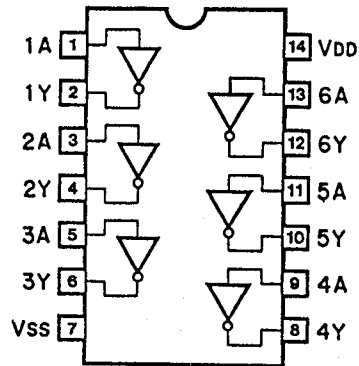

IC701: MN6471M
Digital Filter & D/A Converter

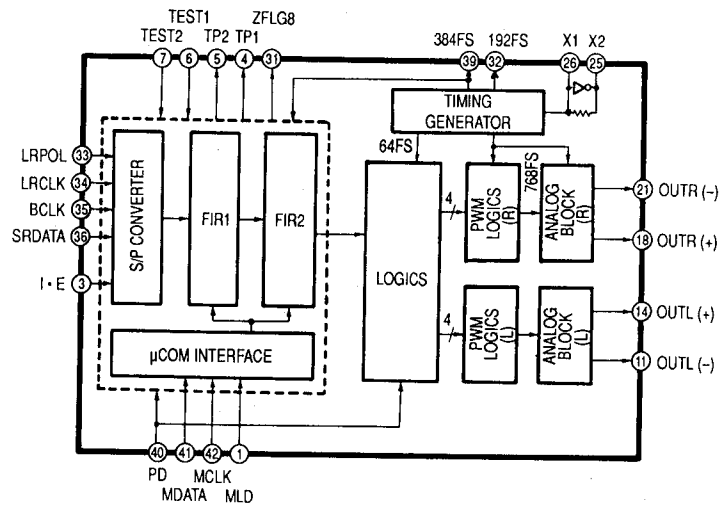

IC BLOCK DIAGRAM IN CD MECHANISM

IC101: AN8373S
Servo Amp.

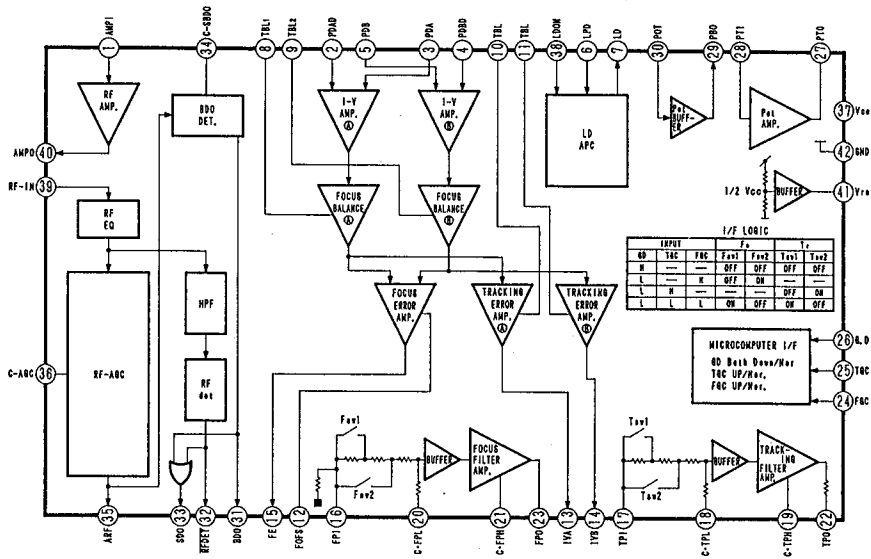

IC102: AN8374S
Servo Processor

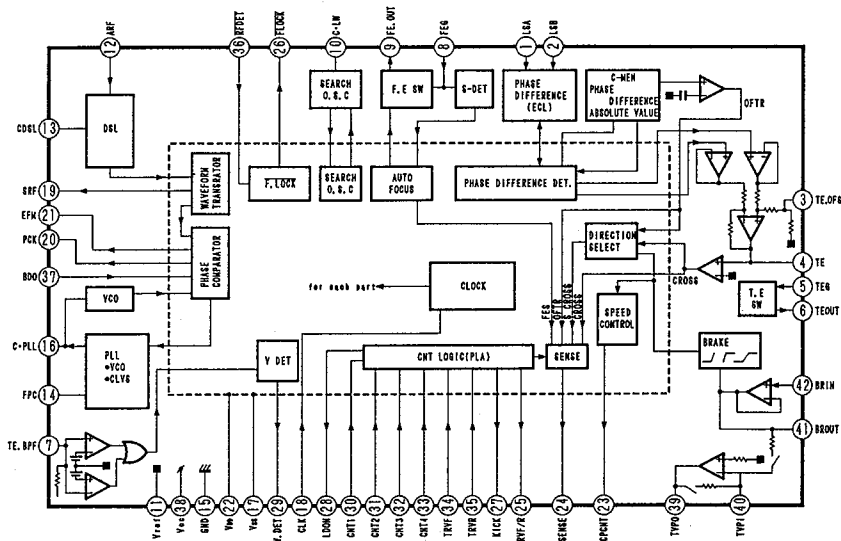

IC103: AN8377N
Focus/Tracking/Traverse Coil Drive

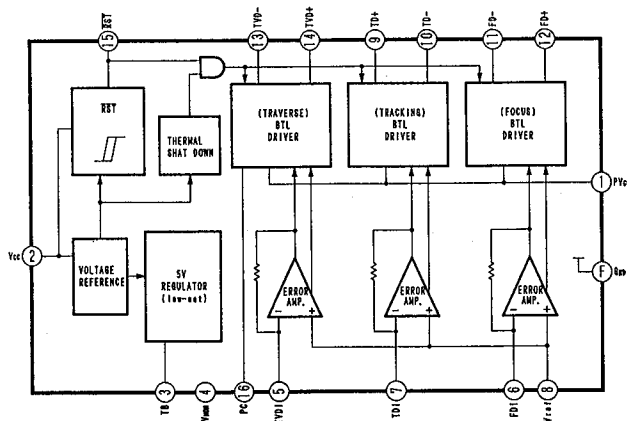

GENERAL UNIT PARTS LIST

Ref. No.	Part No.	Description	Ref. No.	Part No.	Description
AA	A412-TL8600A	CABINET TOP ASSEMBLY EB	223	2240-7381	HOLDER, DUST COVER
AA	A412-TL8600B	CABINET TOP ASSEMBLY WB	224	2240-7382	HOLDER, OPEN LEVER
AB	A442-TL8600A	CABINET FRONT ASSEMBLY	225	2240-7383	HOLDER, FRONT FL (x2)
AC	A319-TL8600A	LEG ASSEMBLY	226	2240-7383	HOLDER, TOP FL (x2)
AD	B622-TL8600A	GEAR ASSEMBLY, DAMPER	227	2240-7384	HOLDER, AC CORD
AE	A424-TL8600A	CABINET BOTTOM ASSEMBLY EB	228	2240-R0101	HOLDER, WIRING (x11)
AE	A424-TL8600B	CABINET BOTTOM ASSEMBLY WB	230	2360-7024	SPECIAL BOSS, MECHA LOCK
AG	B219-TL8600A	METAL FITTING ASSEMBLY, PICK-UP ARM	231	2402-055	PLASTIC WASHER, GEAR (x4)
AH	B601-TL8600A	SHAFT ASSEMBLY	232	2403-702	WASHER, POLY
AI	B211-TL8600A	CHASSIS ASSEMBLY	233	2403-401	POLY WASHER, PLANETARY GEAR
AJ	B219-TL8600B	METAL FITTING ASSEMBLY, HINGE	234	2403-702	POLY WASHER (x3)
AK	B240-TL8600A	HOLDER ASSEMBLY EB	235	2601-7194	SHAFT, GEAR
AK	B240-TL8600B	HOLDER ASSEMBLY WB	236	2601-7198	SHAFT, ROLLER (x5)
AL	B674-TL8600A	SLIDER ASSEMBLY	238	2611-00301	DRUM, PULLEY
022	2132-R0131044	SPACER (x2) WB	239	2617-065	WHEEL, CLAMPER
023	2327-301649	SCREW, BND+ (3x16mm)(x2) WB	240	2618-00101	MOTOR PULLEY, MOTOR
024	2440-7017	NUT, SPECIAL WB	241	2622-062	PLASTIC GEAR, PLANETARY
129	1756-21301	LABEL, TRANSPORT LOCKFNG	242	2622-063	PLASTIC GEAR, PULLEY
130	1756-11123	LABEL, TRANSPORT LOCKFNG	243	2622-064	PLASTIC GEAR, IDLER (x2)
133	1319-02301	LEG, SHORT	244	2622-065	PLASTIC GEAR, DUST COVER
134	1319-03401	LEG, LONG (x3)	246	2642-01468	BELT, MOTOR PULLEY
136	1412-19202	CABINET EB	247	2671-001	CAM, UP/DOWN
136	1412-19204	CABINET WB	248	2674-7021	SLIDER, UP/DOWN
137	1742-07501	ORNAMENT, CABINET	251	2672-7046	LEVER, GEAR
138	1424-33401	CABINET BACK, BOTTOM	252	2672-7047	LEVER, ROLLER
139	1442-25902	PANEL, FRONT	253	2672-7048	LEVER, STOPPER
140	1472-02301	DUST COVER, TOP	254	2672-7049	LEVER, DOOR OPEN
141	1472-02401	DUST COVER, PICK-UP ARM	255	2672-7050	LEVER, OPEN BUTTON
142	1512-07102	PLATE, TURN TABLE	257	2651-2101737	SPRING, BASE MECHA (x2)
144	1511-21701	PLATE, FRONT FL	258	2651-2101738	SPRING, BASE MECHA
145	1511-21802	PLATE, TOP FL	259	2651-2101710	SPRING, GEAR
147	1532-20301	WINDOW, FRONT	261	2651-2101727	SPRING, OPEN BUTTON
149	1632-20401	ROTARY KNOB, OUTPUT LEVEL	262	2651-053	SPRING, OPEN LEVER
151	1662-63001	PUSH BUTTON, POWER	263	2651-054	SPRING, STOPPER LEVER
152	1662-63101	PUSH BUTTON, DOOR RELEASE	264	2651-055	SPRING, ROLLER LEVER
153	1662-63202	PUSH BUTTON, DISC NO.	265	2651-060	SPRING, POWER BUTTON
154	1662-63301	PUSH BUTTON, TRACK NO.	266	2652-136	LEAF SPRING, PICK-UP ARM
155	1662-63401	PUSH BUTTON, DISPLAY	267	2652-129	LEAF SPRING, UP/DOWN
156	1662-63501	PUSH BUTTON, DISC SKIP	268	2401-033	METAL WASHER (x3)
159	1744-06701	ORNAMENT, LONG LEG (x3)	269	2401-035	METAL WASHER (x5)
160	1742-07601	ORNAMENT, FRONT	270	2401-068	METAL WASHER
161	1341-568	NAME PLATE, PRODUCTION DATE EB	271	2459-3006511	PLASTIC RIVET
162	1756-03305	LABEL, LASER CAUTION	272	2459-3004511	PLASTIC RIVET, LED P.C.B
163	1756-09602	LABEL, LASER CAUTION EB	273	2461-402	E-STOPPER (x4)
164	1756-CSA	LABEL EB	274	2461-302	E-STOPPER
167	1756-11801	LABEL, LASER WARNING	275	2461-604	E-STOPPER (x2)
168	1751-01018	LABEL, UL EB	281	2327-R0126064	SCREW, BND+ (2.6x6mm)(x4)
170	2111-11774	FELT, DUST COVER	282	2327-R0130052	SCREW, BND+ (3x5mm)(x2)
172	2111-1388	FELT, MAGNET	283	2327-R0130082	SCREW, BND+ (3x8mm)
173	2111-245	FELT, LONG LEG (x3)	285	2347-261027	SCREW, BND T+ (2.6x10mm)
174	2114-017	BUSHING, GUIDE ROLLER (x5)	287	2347-300547	SCREW, BND T+ (3x5mm)(x5)
175	2114-018	BUSHING, BASE MECHA (x3)	288	2347-301047	SCREW, BND T+ (3x10mm)(x2)
176	2114-019	BUSHING, GEAR CHASSIS (x3)	290	2347-R0126052	SCREW, BND T+ (2.6x5mm)(x2)
178	2132-R0131044	SPACER, CAM SWITCH	291	2347-R0126082	SCREW, BND T+ (2.6x8mm)(x3)
179	2132-7119	SPACER, LED	292	2347-R0126122	SCREW, BND T+ (2.6x12mm)(x20)
180	2132-7119	SPACER, PHOTE SENSOR	293	2347-R0130102	SCREW, BND T+ (3x10mm)(x27)
181	2132-7168	SPACER, MOTOR	294	2347-R0130162	SCREW, BND T+ (3x16mm)(x6)
182	2132-R0131035	SPACER	296	2347-R0126084	SCREW, BND T+ (2.6x8mm)(x6)
183	2211-7315	CHASSIS, FRONT	297	2347-R0130084	SCREW, BND T+ (3x8mm)(x13)
184	2211-7316	CHASSIS, GEAR	300	2347-R0140164	SCREW, BND T+ (4x16mm)(x8)
185	2216-7192	SHIELD PLATE, HEADPHONES	302	2557-300629	SCREW, B SPW+
186	2216-7193	SHIELD PLATE, OUTPUT	303	2347-R0126082	SCREW, BND T+ (2.6x8mm)(x6)
187	2216-7196	SHIELD PLATE, CABINET	304	2347-R0130062	SCREW, BND T+ (3x6mm)(x9)
189	2218-R0130	FIX BRACKET (x4)	308	3119-02201	CD MECHA ASSEMBLY
190	2218-7038	FIX BRACKET, TOP FL	309	4291-028	MAGNET, CRAMPER
191	2219-8306	METAL FITTING, PICK-UP ARM	832	2440-62	NUT, HEX
192	2219-8307	METAL FITTING, TABLE SHAFT	△ P1	4161-03601202	AC CORD W/PLUG, AC120V EB
193	2219-8308	METAL FITTING, MAGNET	△ P1	4161-03701220	AC CORD W/PLUG, AC220V/240V WB
194	2219-8309	METAL FITTING, OUTPUT LEVEL			
195	2219-8310	METAL FITTING, PANEL CABINET			
196	2219-8311	METAL FITTING, FRONT CHASSIS			
197	2219-8312	METAL FITTING, MAIN P.C.BOARD (x2)			
199	2219-8313	METAL FITTING, DUST COVER, L			
200	2219-8314	METAL FITTING, DUST COVER, R			
201	2219-8315	METAL FITTING, HINGE (x2)			
202	2219-8316	METAL FITTING, HINGE BASE (x2)			
203	2219-8337	METAL FITTING, AC CORD			
205	2401-0841	METAL WASHER, HINGE (x4)			
206	2419-800	WAVE WASHER, HINGE (x4)			
207	2601-7193	SHAFT, HINGE (x2)			
208	2651-052	SPRING, HINGE (x2)			
214	2222-7217	HEAT SINK			
217	2240-7378	HOLDER, DAMPER BASE			
219	2622-066	GEAR, PLASTIC, DAMPER			
221	2240-7377	HOLDER, CD MECHA			
222	2240-7380	HOLDER, MECHA LOCK			

NOTE



SAFETY RELATED COMPONENT. USE ONLY EXACT REPLACEMENT PART AS SPECIFIED.

GENERAL UNIT
EXPLODED VIEW

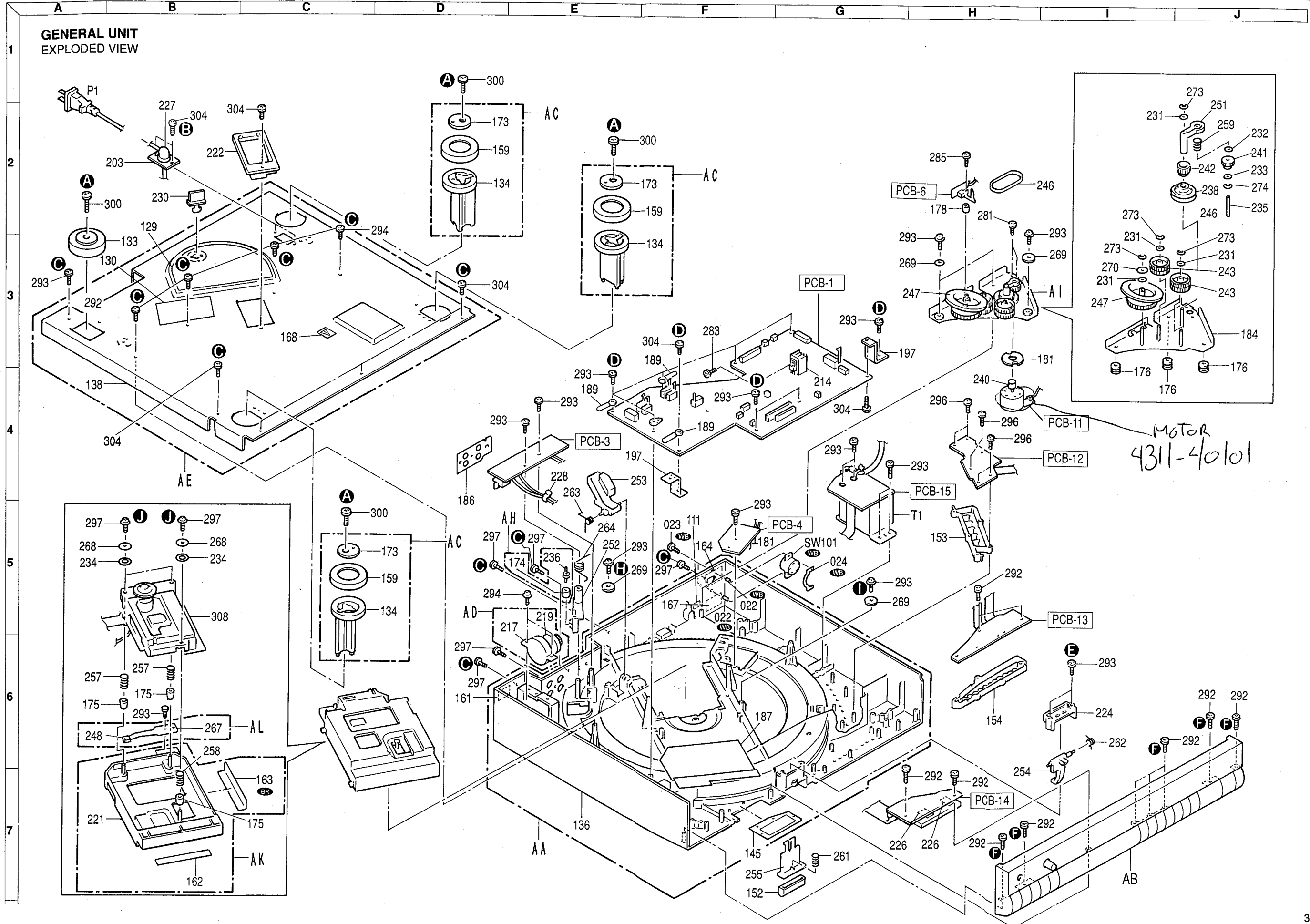

**GENERAL UNIT
EXPLODED VIEW**

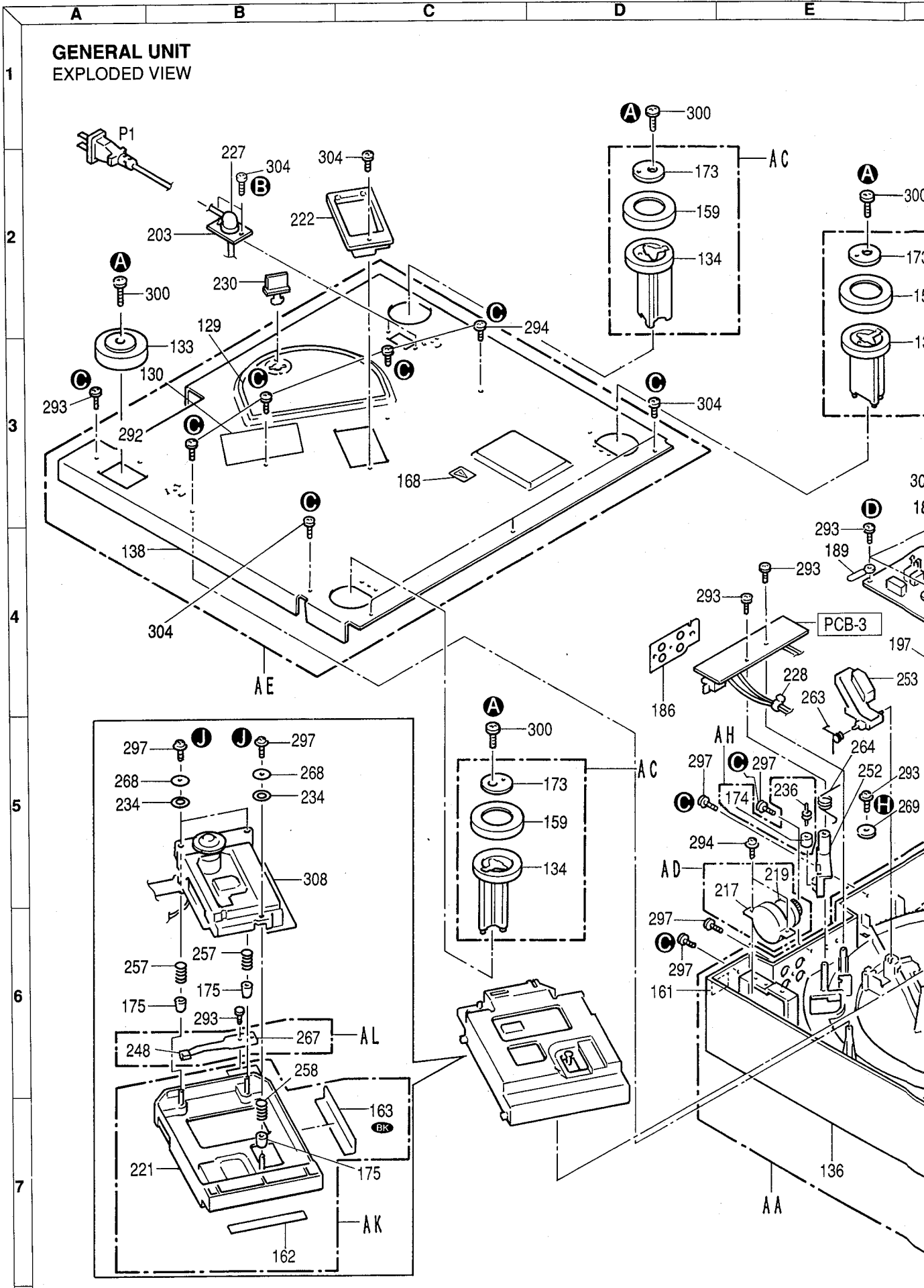

F G H I J

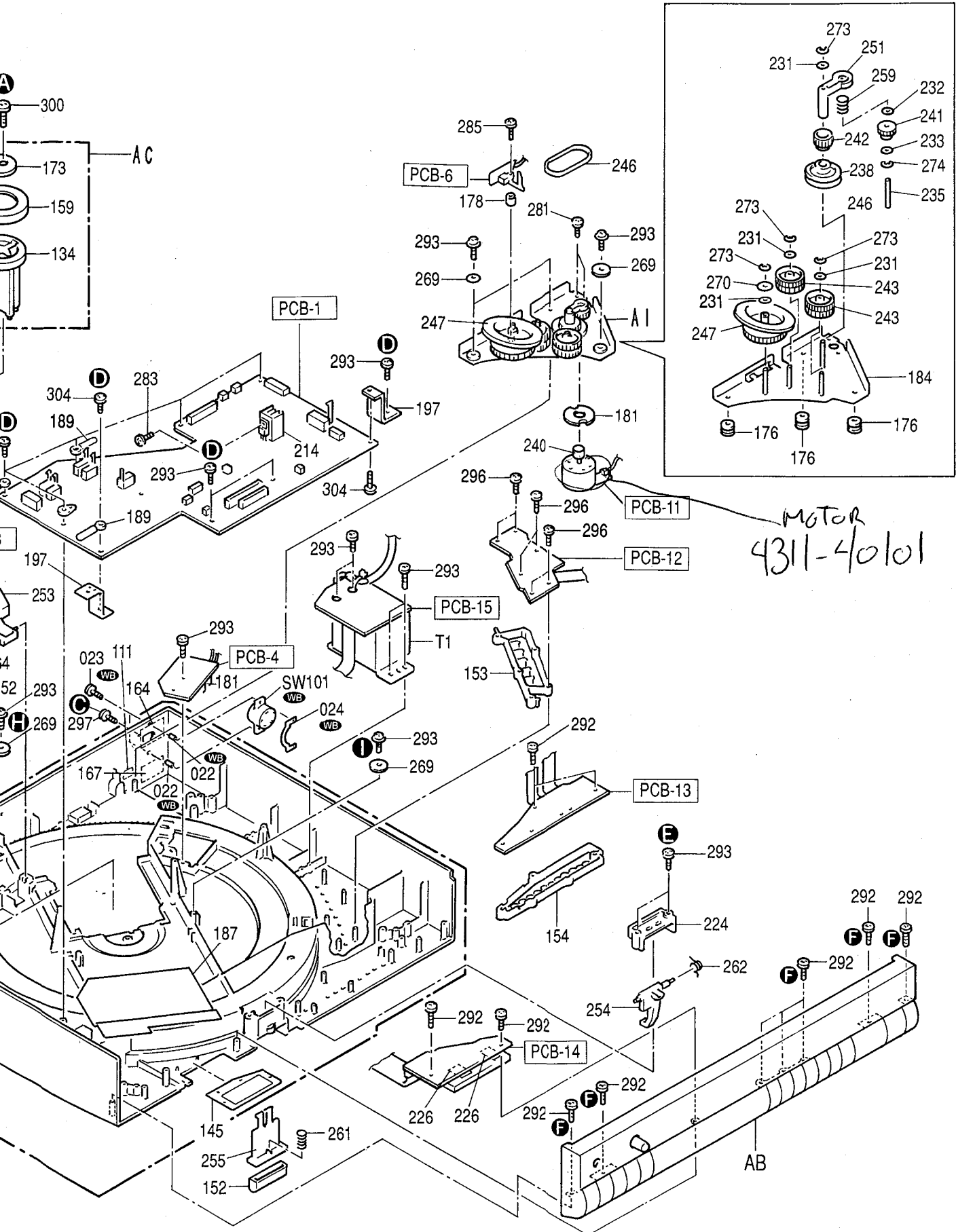

DUST COVER & TURN TABLE
EXPLODED VIEW

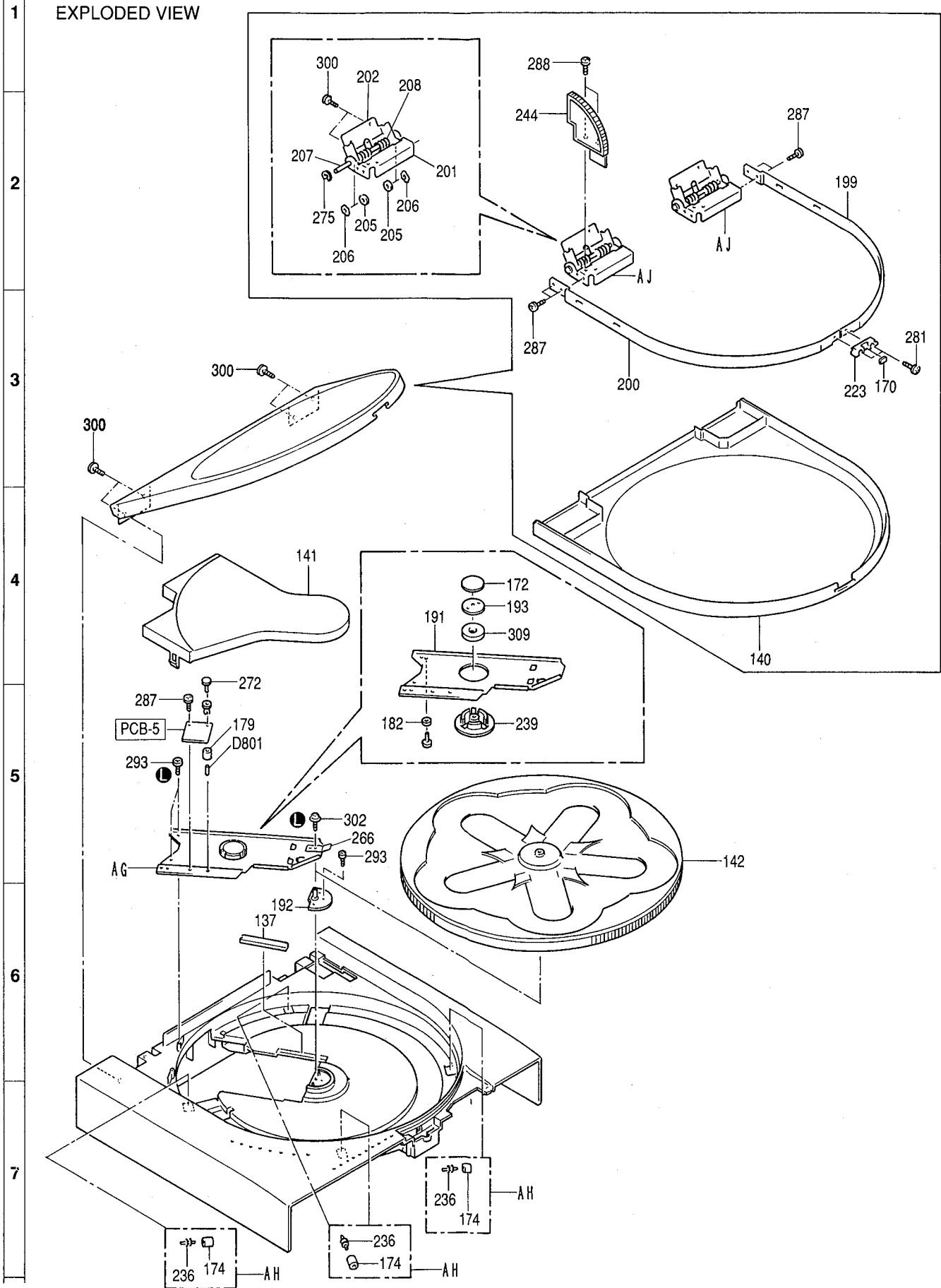

CABINET FRONT
EXPLODED VIEW

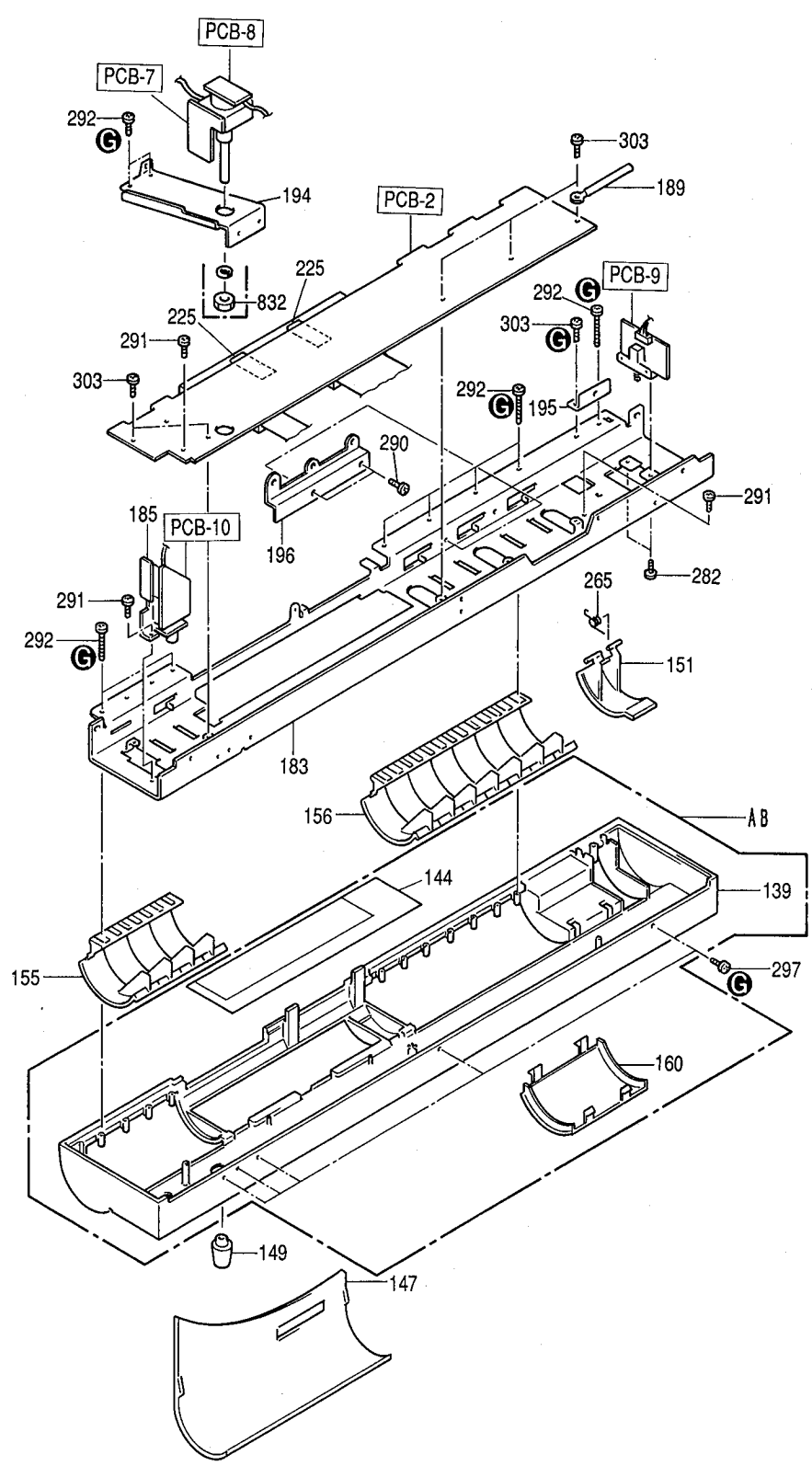

DUST COVER & TURN TABLE
EXPLODED VIEW

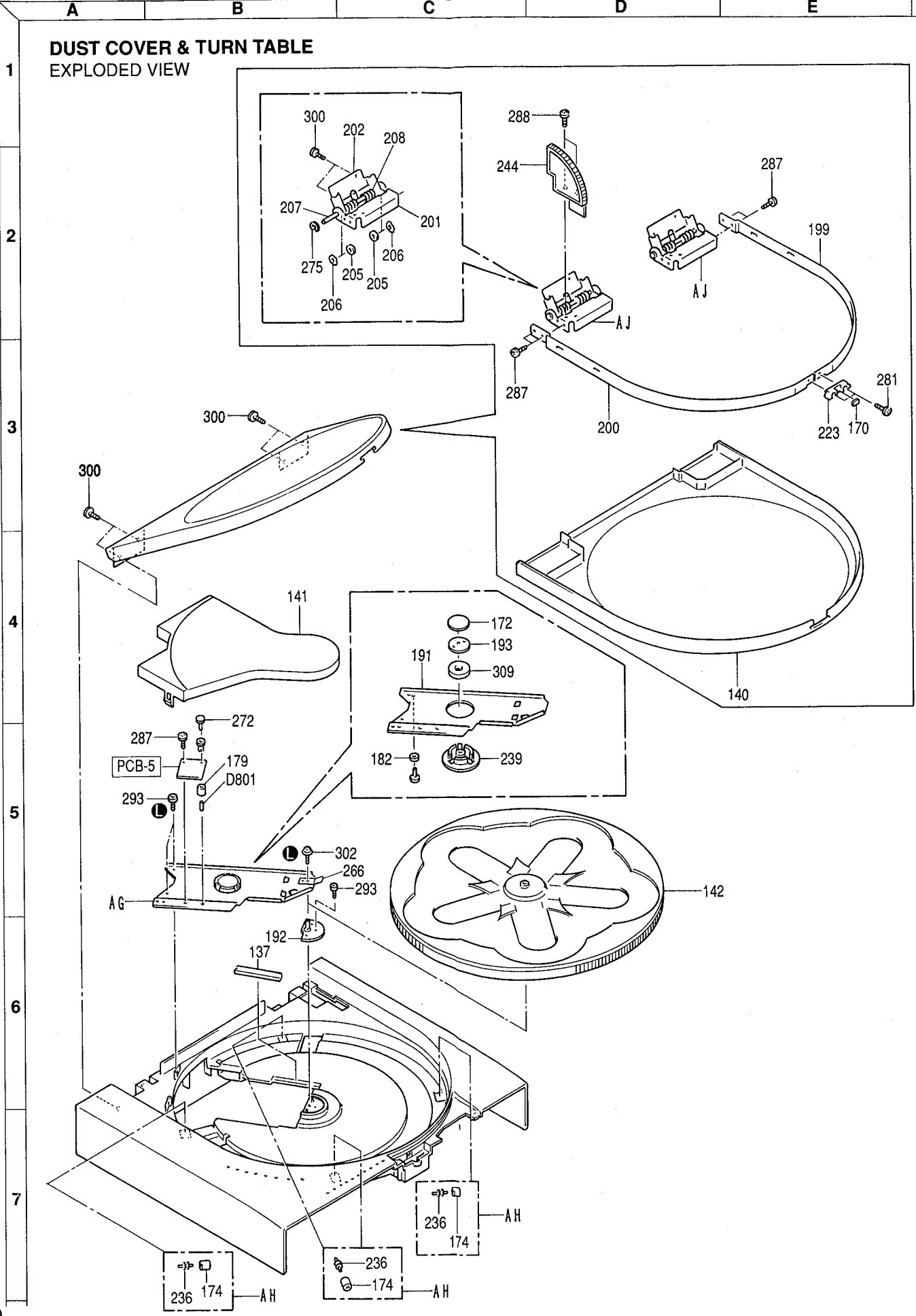

CABINET FRONT EXPLODED VIEW

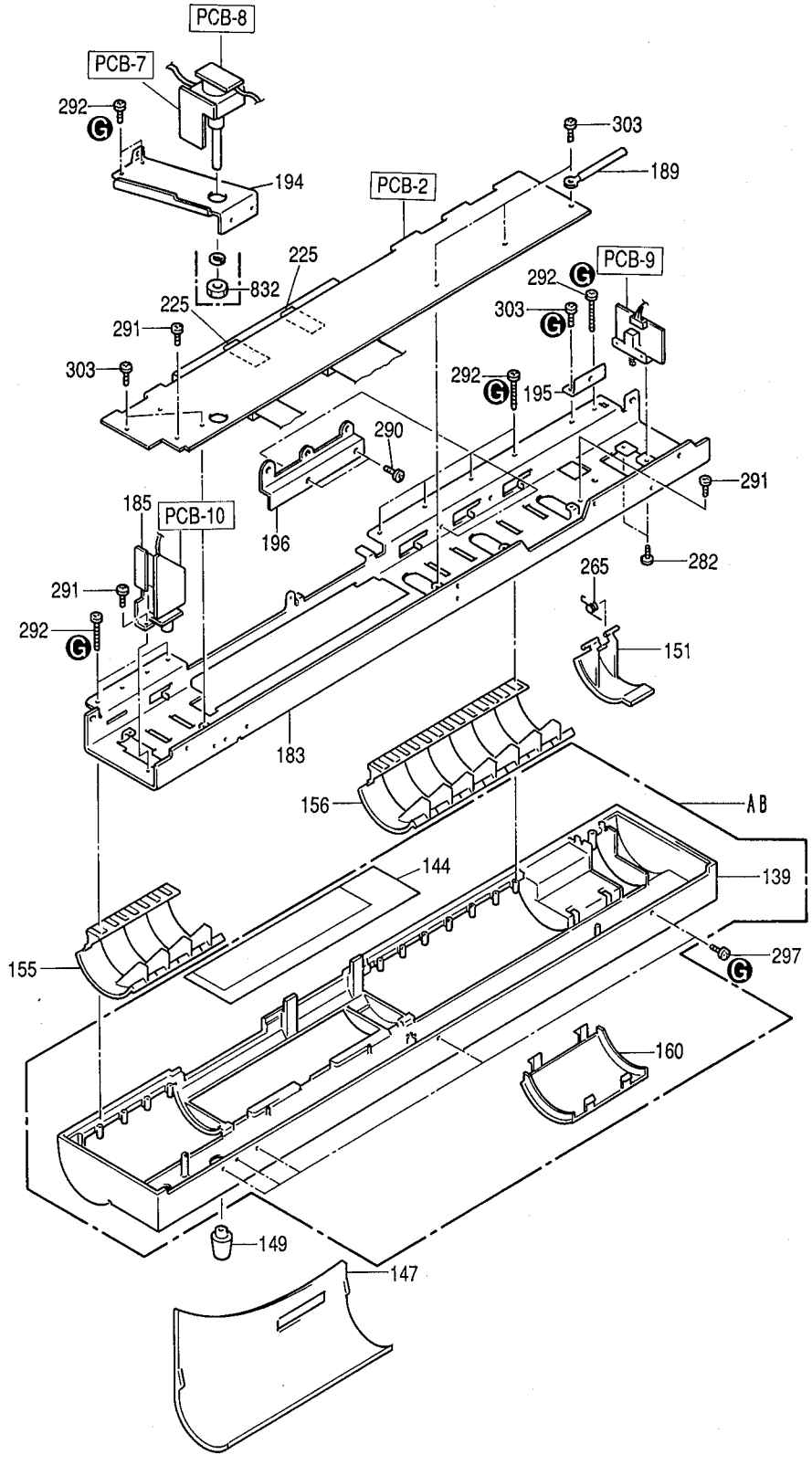

BLOCK DIAGRAM

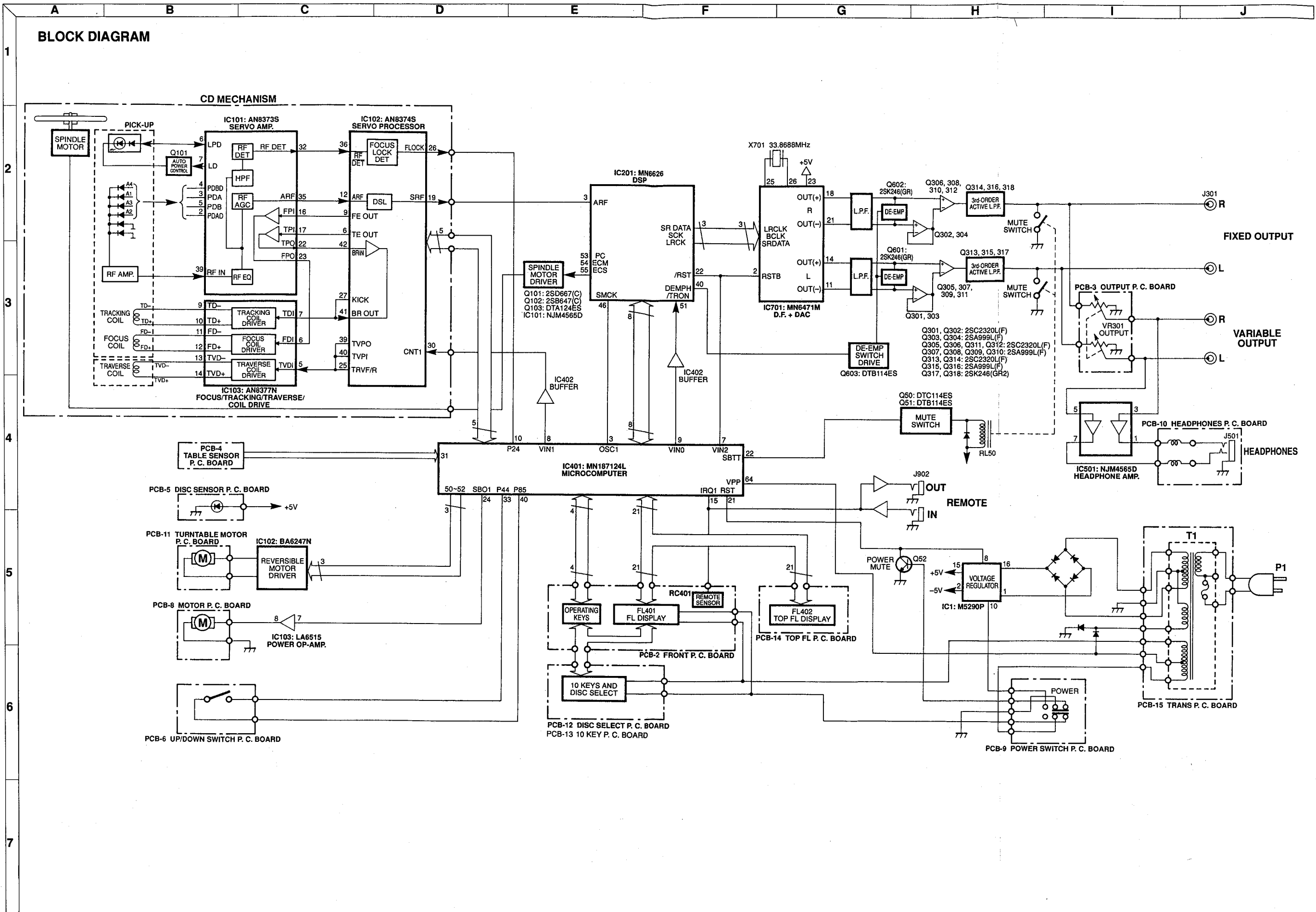

BLOCK DIAGRAM

1
2
3
4
5
6
7

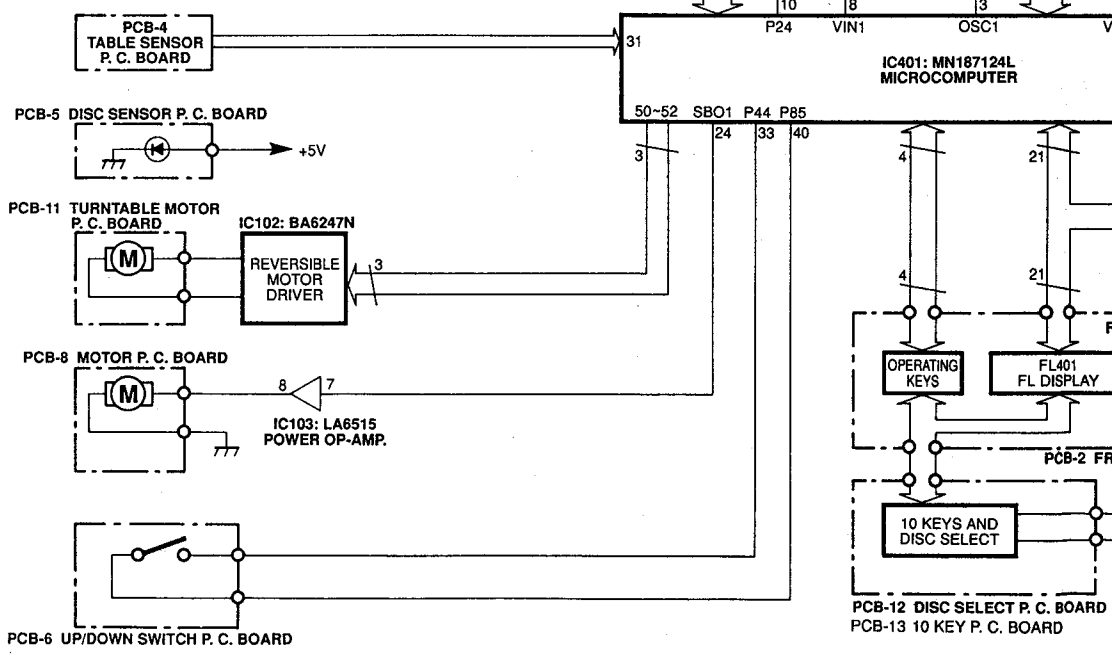
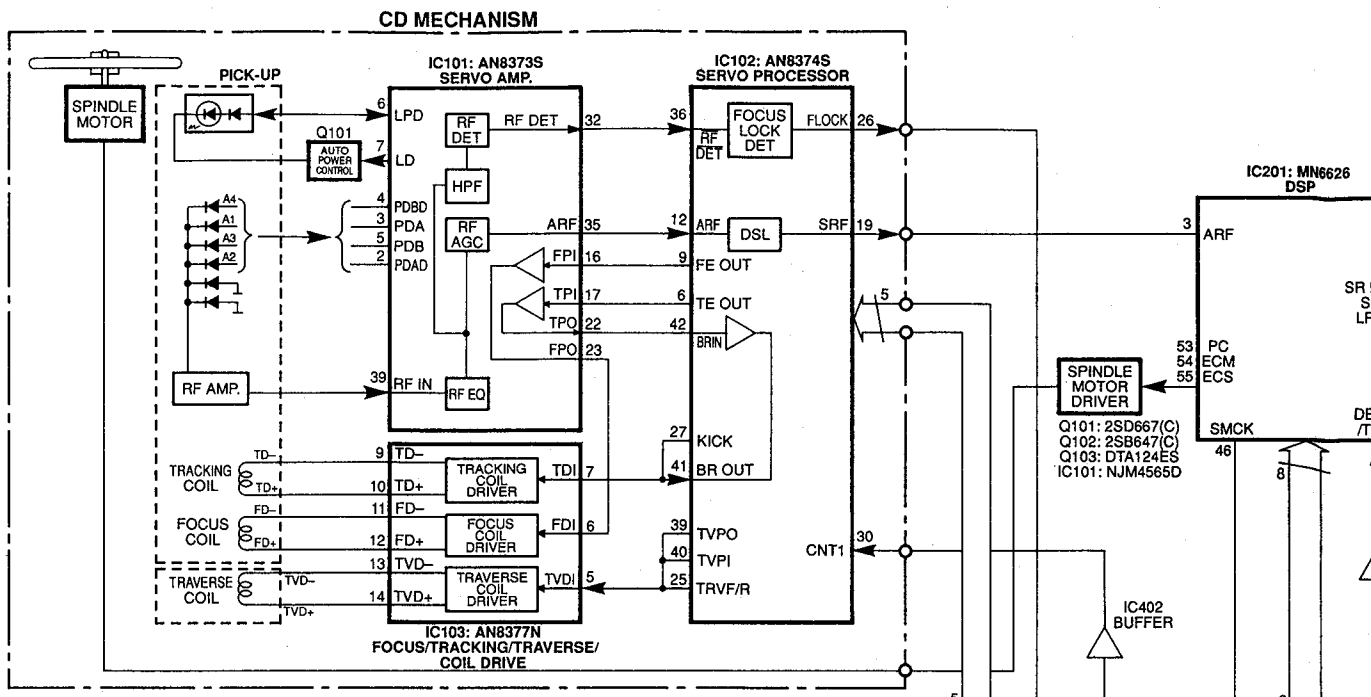

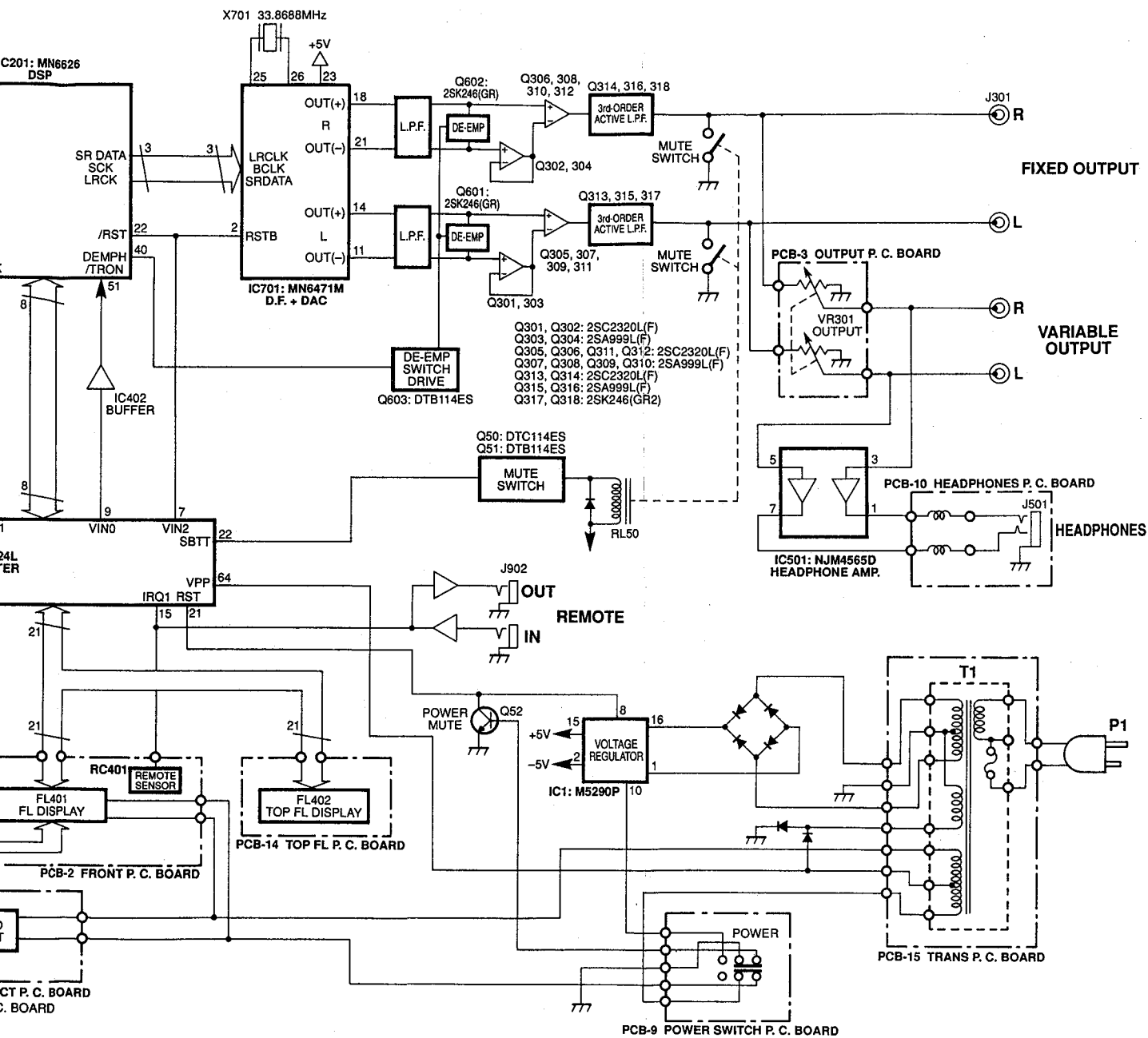

WIRING DIAGRAM

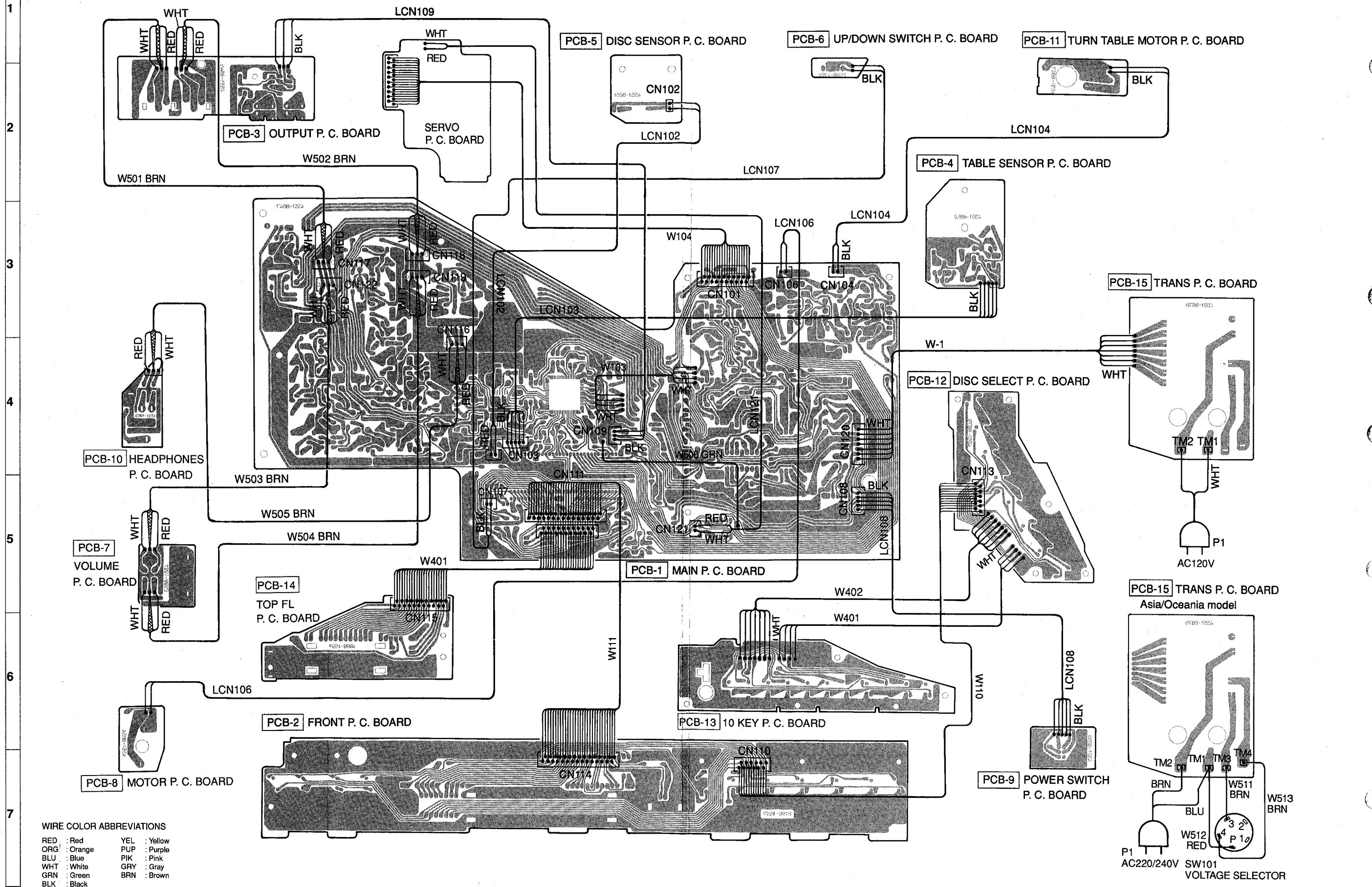

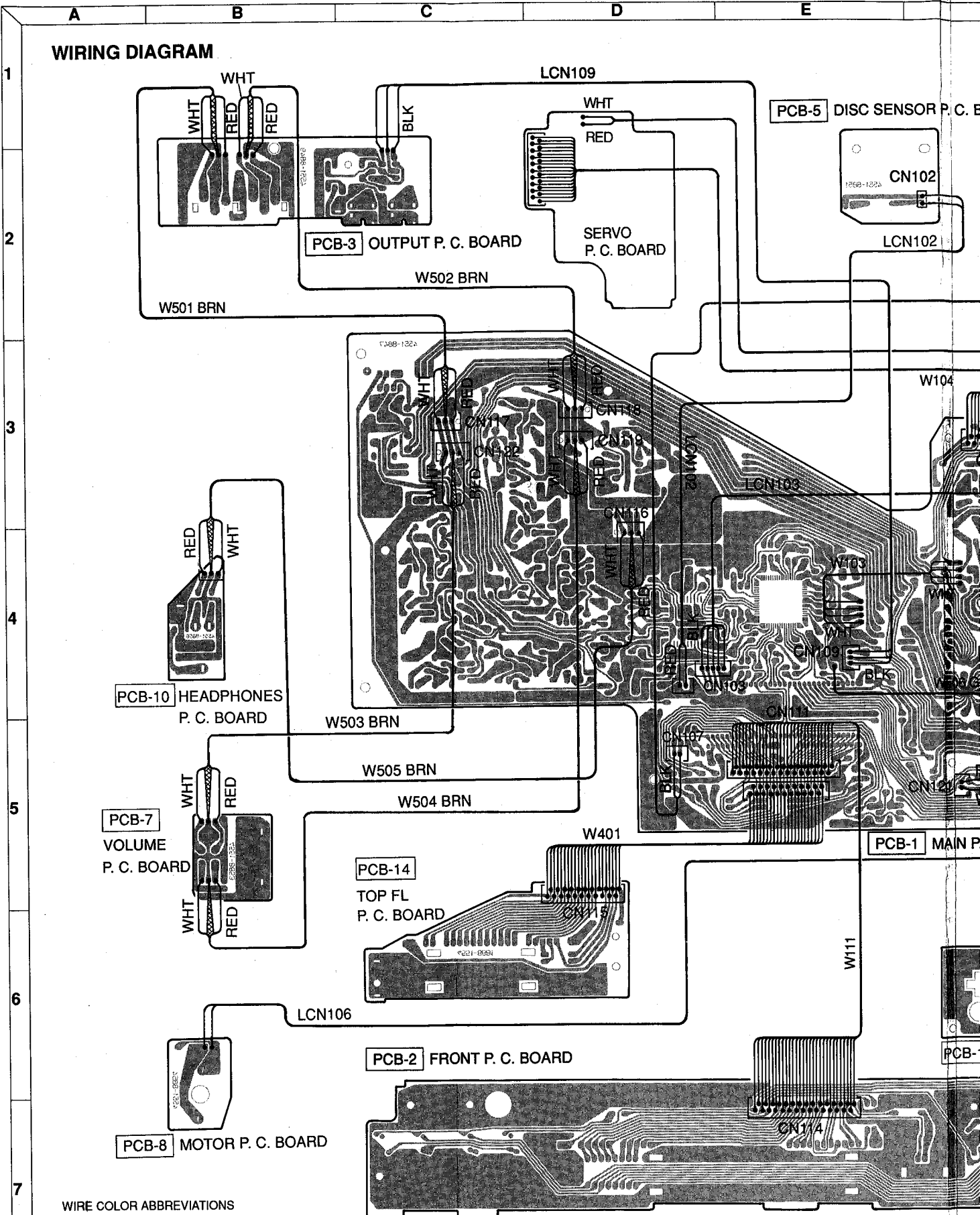

WIRING DIAGRAM

WIRE COLOR ABBREVIATIONS

RED : Red	YEL : Yellow
ORG : Orange	PUP : Purple
BLU : Blue	PIK : Pink
WHT : White	GRY : Gray
GRN : Green	BRN : Brown
BLK : Black	

OR P. C. BOARD

PCB-6 UP/DOWN SWITCH P. C. BOARD

PCB-11 TURN TABLE MOTOR P. C. BOARD

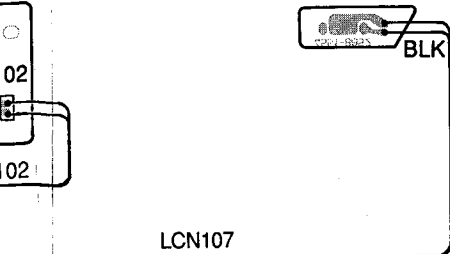

PCB-4 TABLE SENSOR P. C. BOARD

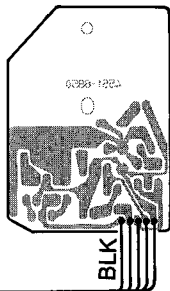

PCB-15 TRANS P. C. BOARD

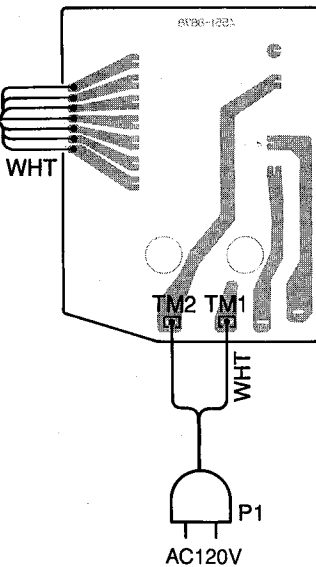

PCB-12 DISC SELECT P. C. BOARD

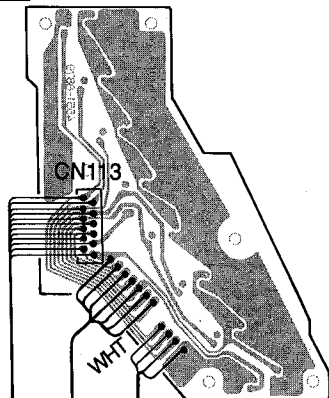

PCB-15 TRANS P. C. BOARD
Asia/Oceania model

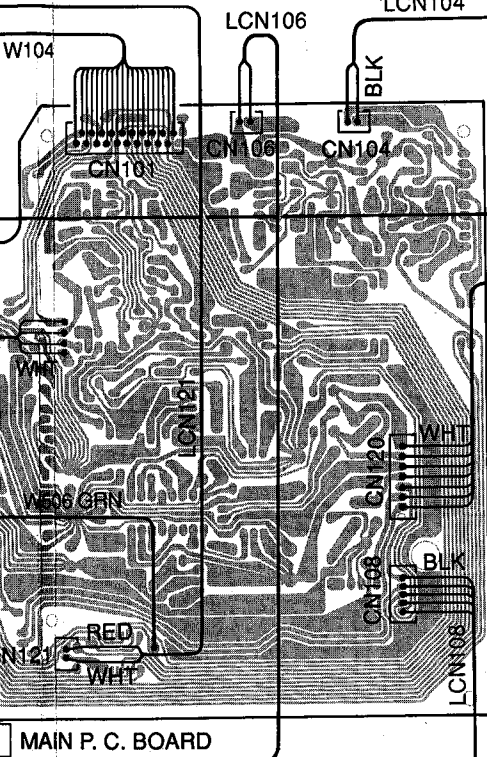
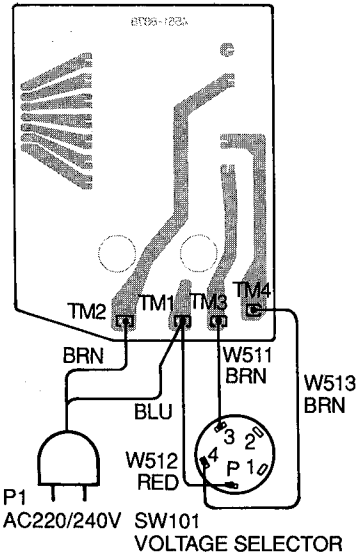

PCB-13 10 KEY P. C. BOARD

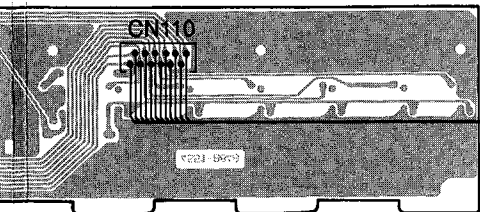

PCB-9 POWER SWITCH P. C. BOARD



P. C. BOARDS (1)

PCB-1 MAIN P. C. BOARD

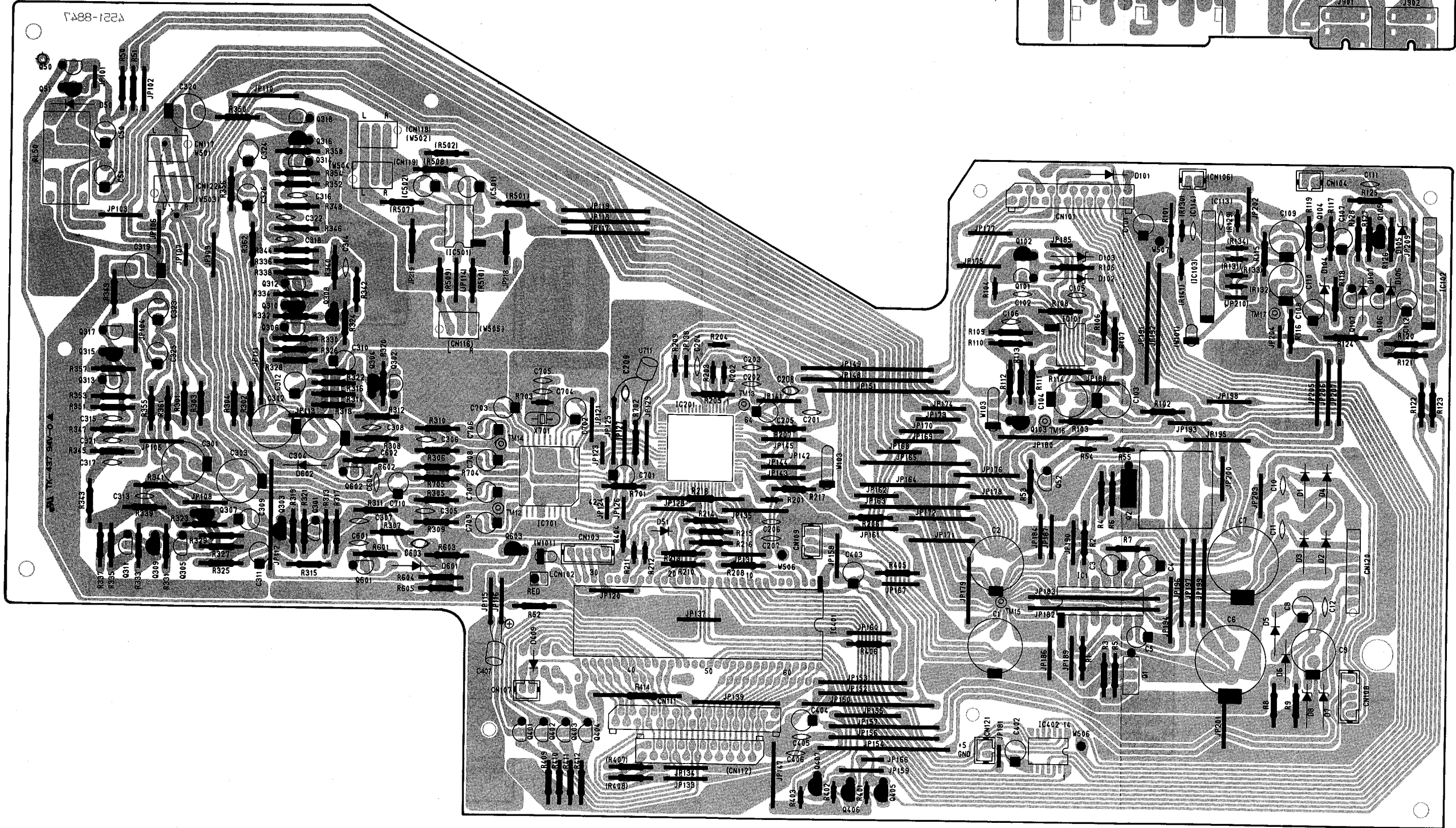

PCB-3 OUTPUT P. C. BOARD

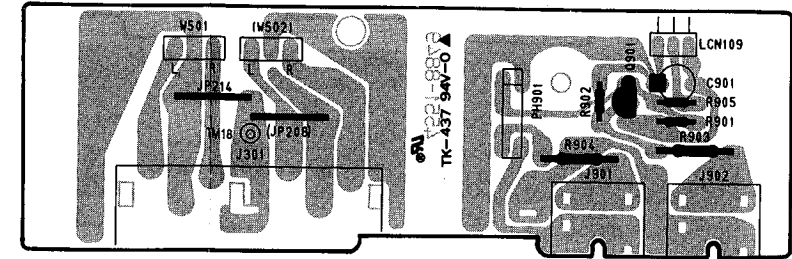

1
2
3
4
5
6
7

P. C. BOARDS (1)

PCB-1 MAIN P. C. BOARD

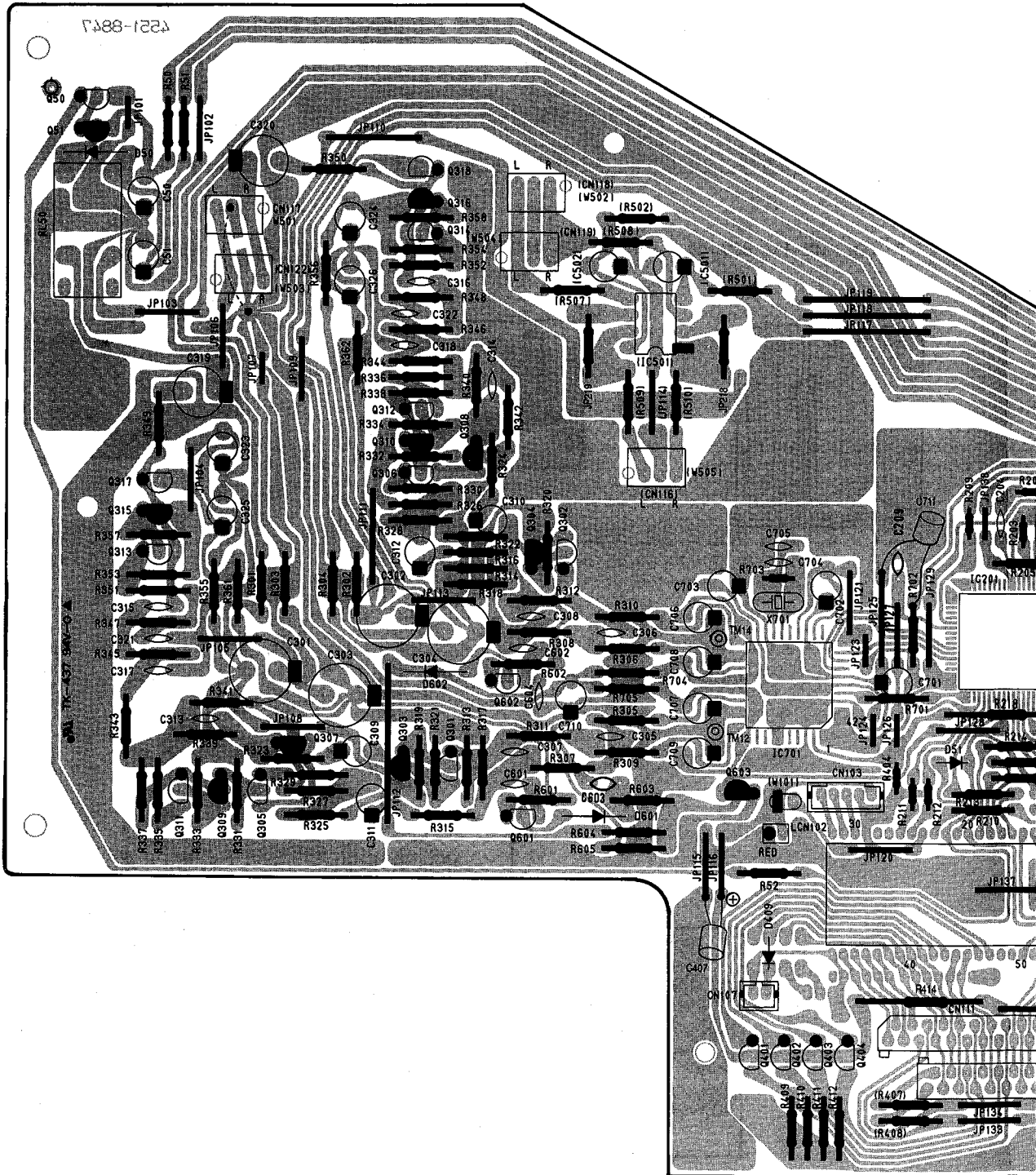

PCB-3 OUTPUT P. C. BOARD

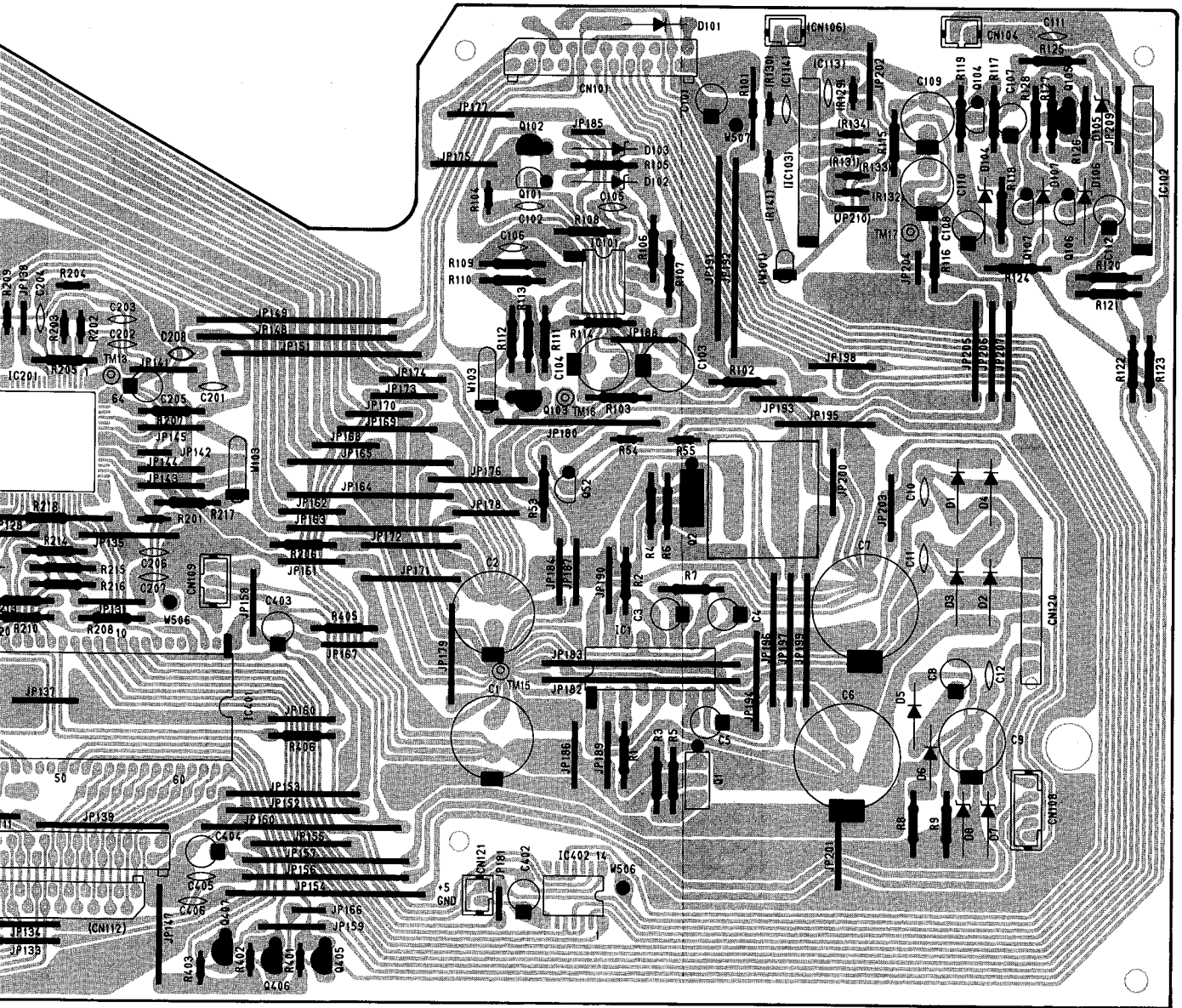
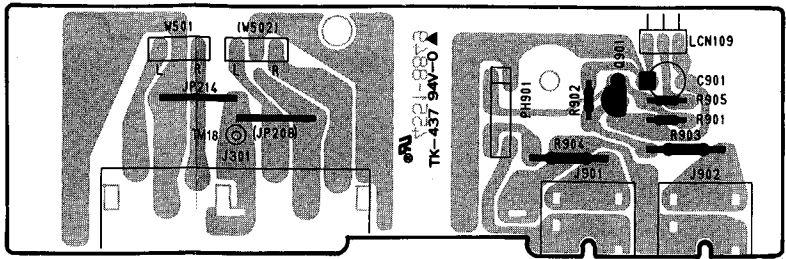

P. C. BOARDS (2)

PCB-2 FRONT P. C. BOARD

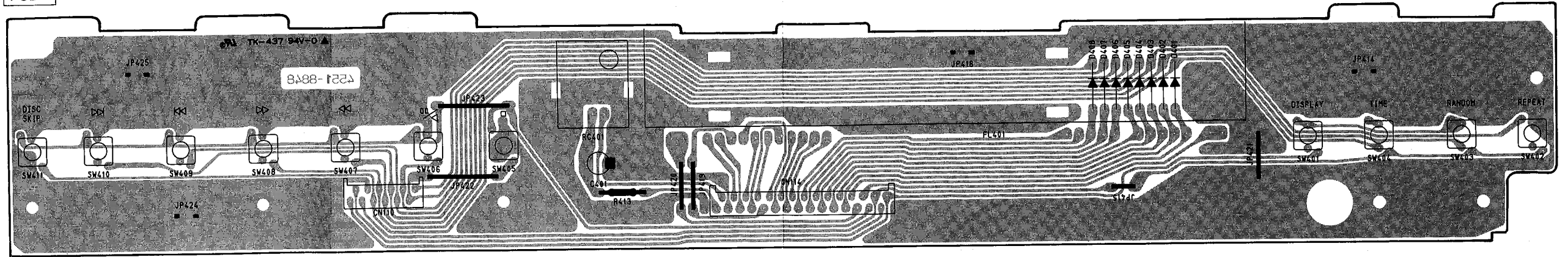

PCB-4 TABLE SENSOR P. C. BOARD

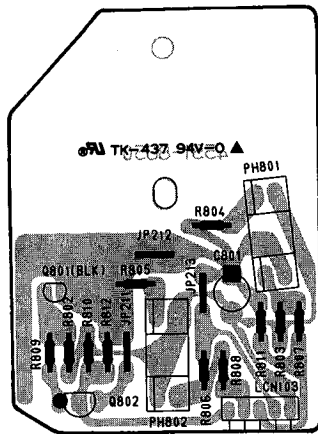

PCB-5 DISC SENSOR P. C. BOARD

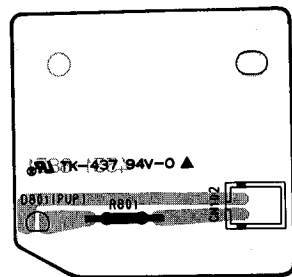

PCB-6 UP/DOWN SWITCH P. C. BOARD



PCB-7 VOLUME P. C. BOARD

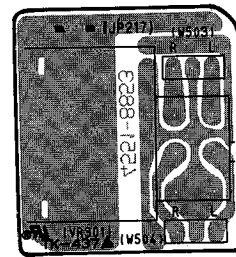

PCB-8 MOTOR P. C. BOARD

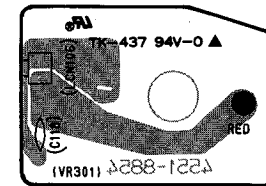

PCB-9 POWER SWITCH P. C. BOARD

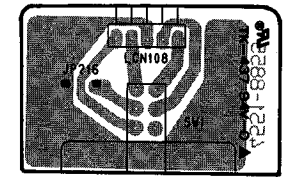

PCB-10 HEADPHONES P. C. BOARD

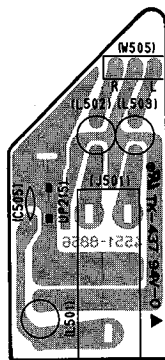

PCB-11 TURN TABLE MOTOR P. C. BOARD

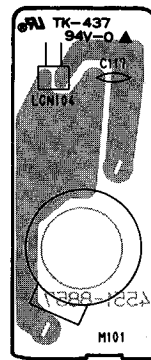

PCB-12 DISC SELECT P. C. BOARD

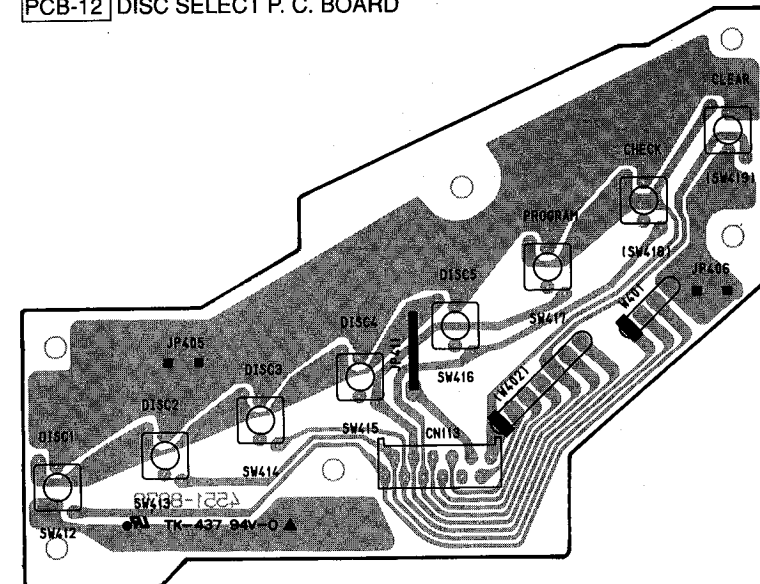

P. C. BOARDS (2)

PCB-2 FRONT P. C. BOARD

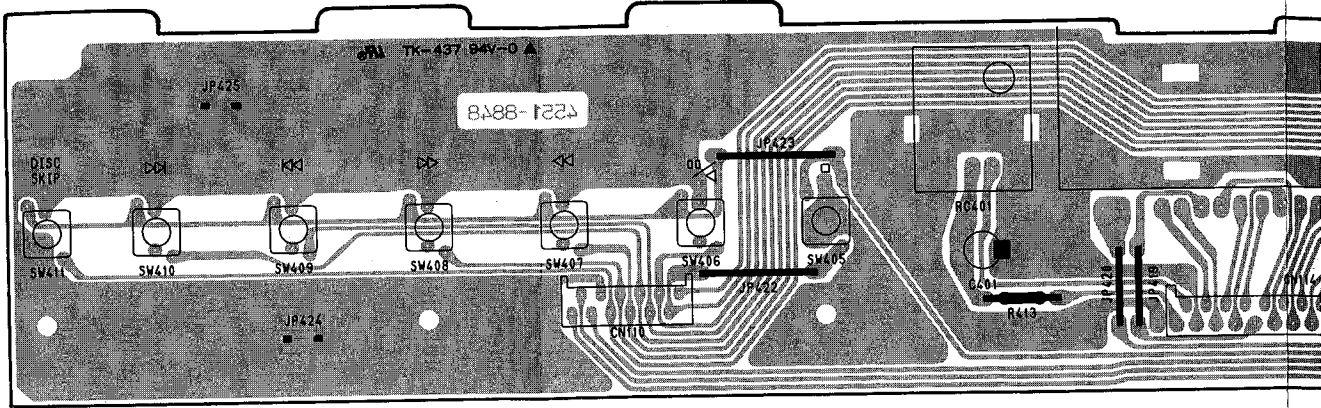

PCB-4 TABLE SENSOR P. C. BOARD

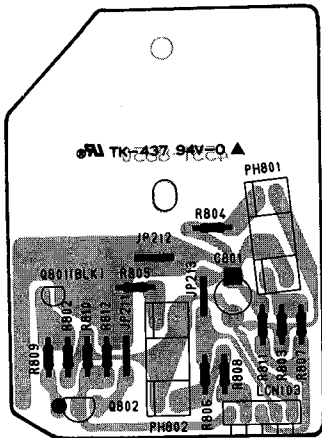

PCB-5 DISC SENSOR P. C. BOARD

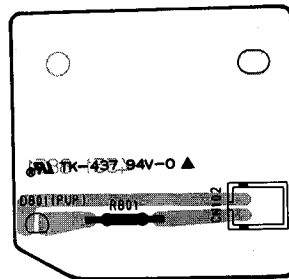

PCB-6 UP/DOWN SWITCH P. C. BOARD



PCB-10 HEADPHONES P. C. BOARD

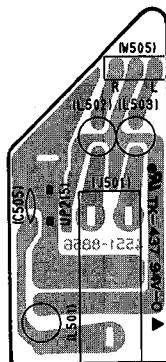

PCB-11 TURN TABLE MOTOR P. C. BOARD

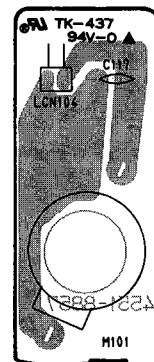

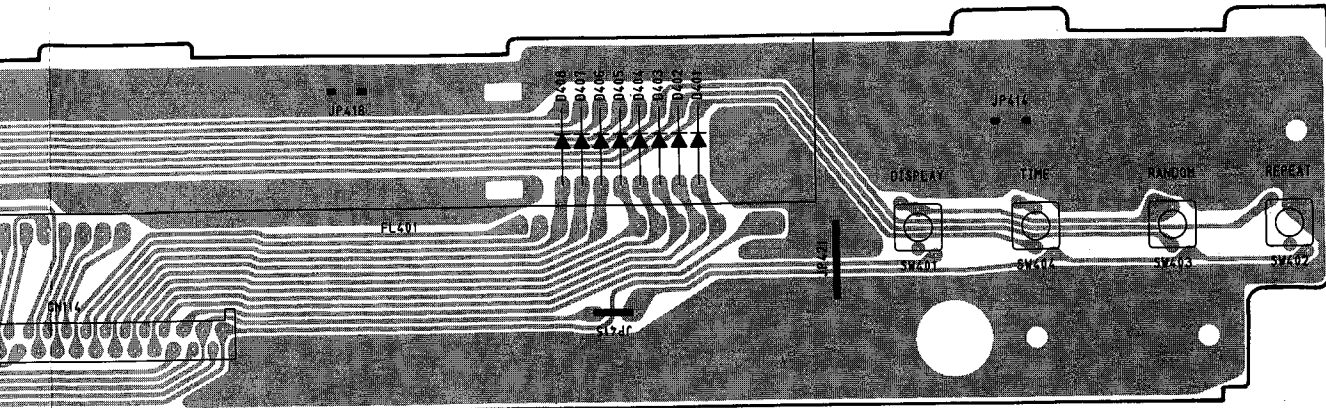

PCB-7 VOLUME P. C. BOARD

PCB-8 MOTOR P. C. BOARD

PCB-9 POWER SWITCH P. C. BOARD

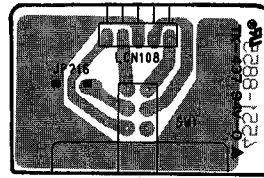
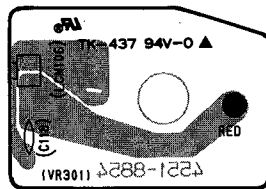
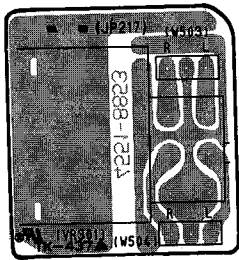

PCB-12 DISC SELECT P. C. BOARD

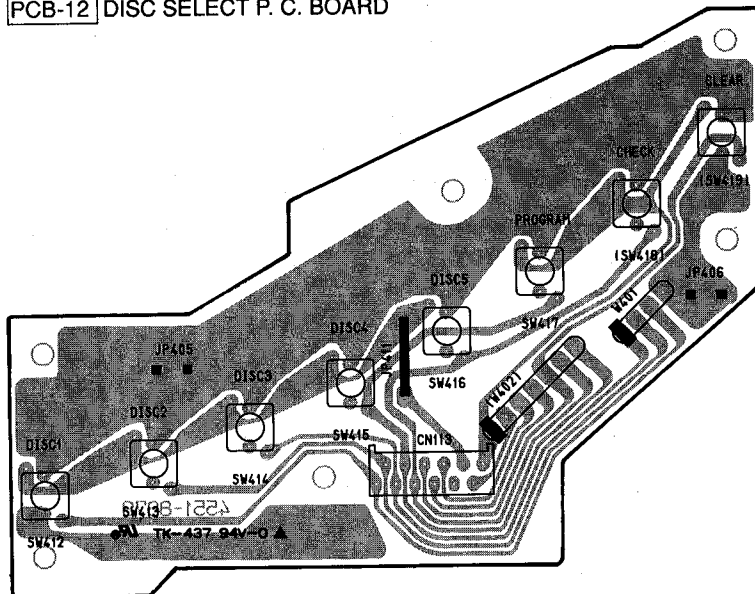

P. C. BOARDS (3)

PCB-13 10 KEY P. C. BOARD

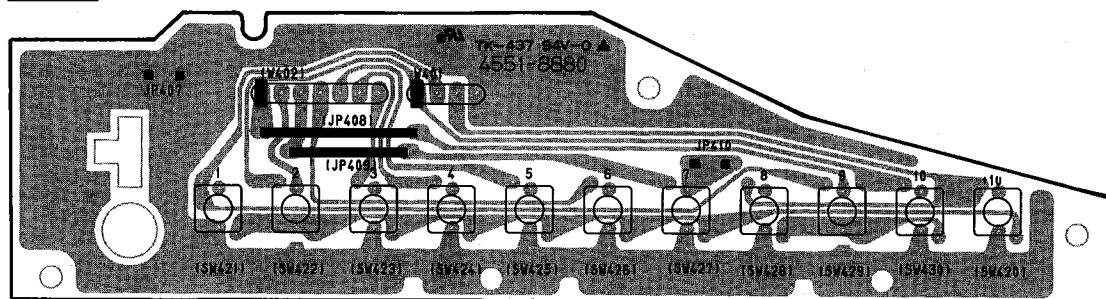

PCB-14 TOP FL P. C. BOARD

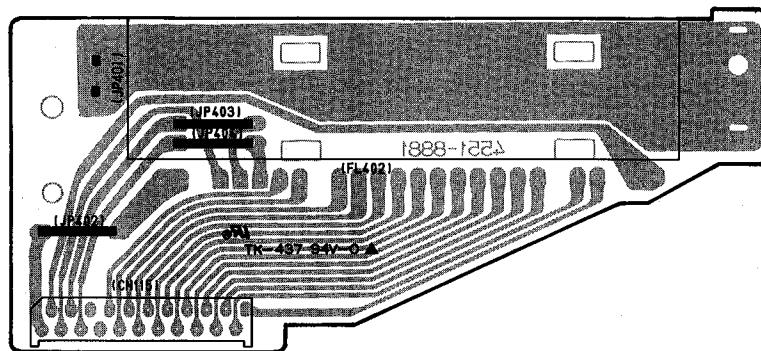

PCB-15 TRANS P. C. BOARD

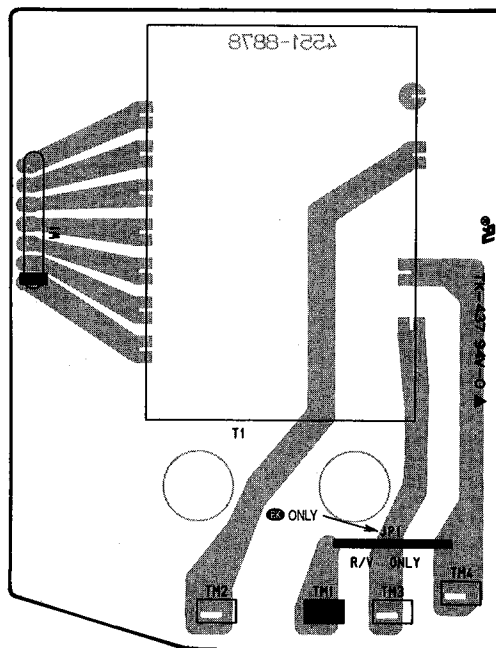

ELECTRICAL PARTS LIST

Ser. No.	Ref. No.	Part No.	Description	Ser. No.	Ref. No.	Part No.	Description
PCB-1 MAIN P. C. BOARD							
CAPACITORS							
789	C1	5345-108C0962	CAP,MINI ELE 1000µ/16V	586	C708	5345-S06BM107	CAP,MINI ELE 100µ/10V
789	C2	5345-108C0962	CAP,MINI ELE 1000µ/16V	586	C709	5345-S06BM107	CAP,MINI ELE 100µ/10V
792	C3	5345-106F0962	CAP,MINI ELE 10µ/50V	586	C710	5345-S06BM107	CAP,MINI ELE 100µ/10V
792	C4	5345-106F0962	CAP,MINI ELE 10µ/50V	RESISTORS			
793	C5	5345-225F0962	CAP,MINI ELE 2.2µ/50V	786	△ R1	5102-1015116	RES,FUSE 100
788	C6	5345-478C0963	CAP,MINI ELE 4700µ/16V	786	△ R2	5102-1015116	RES,FUSE 100
788	C7	5345-478C0963	CAP,MINI ELE 4700µ/16V	782	R3	5135-471522	RES,CBN 1/2P 470
791	C8	5345-226F0962	CAP,MINI ELE 22µ/50V	782	R4	5135-471522	RES,CBN 1/2P 470
790	C9	5345-477E0962	CAP,MINI ELE 470µ/35V	779	R5	5135-2R2522	RES,CBN 1/2P 2.2
794	C10	5354-224593	CAP,MYL .22µ	779	R6	5135-2R2522	RES,CBN 1/2P 2.2
794	C11	5354-224593	CAP,MYL .22µ	785	R7	5135-153522	RES,CBN 1/2P 15K
795	C12	5354-104593	CAP,MYL .1µ	781	R8	5135-121522	RES,CBN 1/2P 120
661	C50	5345-S06BM107	CAP,MINI ELE 100µ/10V	784	R9	5135-223522	RES,CBN 1/2P 22K
661	C51	5345-S06BM107	CAP,MINI ELE 100µ/10V	656	R50	5135-100522	RES,CBN 1/2P 10
728	C101	5345-476C0962	CAP,MINI ELE 47µ/16V	656	R51	5135-100522	RES,CBN 1/2P 10
722	C102	5354-104593	CAP,MYL .1µ	658	R52	5135-102522	RES,CBN 1/2P 1K
726	C103	5345-107C0962	CAP,MINI ELE 100µ/16V	657	R53	5135-332522	RES,CBN 1/2P 3.3K
726	C104	5345-107C0962	CAP,MINI ELE 100µ/16V	659	R54	5232-331J16P	RES,CBN 1/6P 330
721	C105	5354-563593	CAP,MYL .056µ	660	R55	5232-103J16P	RES,CBN 1/6P 10K
723	C106	5359-S010J222	CAP,PPP 2200P	707	△ R101	5102-2R25117F	RES,FUSE 2.2
727	C107	5345-476D0962	CAP,MINI ELE 47µ/25V	706	△ R102	5102-4R75116	RES,FUSE 4.7
727	C108	5345-476D0962	CAP,MINI ELE 47µ/25V	706	△ R103	5102-4R75116	RES,FUSE 4.7
725	C109	5345-227C0962	CAP,MINI ELE 220µ/16V	709	R104	5232-100J16P	RES,CBN 1/6P 10
725	C110	5345-227C0962	CAP,MINI ELE 220µ/16V	698	R105	5135-101522	RES,CBN 1/2P 100
720	C111	5359-S010J223	CAP,PPP .022µ	698	R106	5135-101522	RES,CBN 1/2P 100
729	C112	5345-107A0962	CAP,MINI ELE 100µ/6.3V	696	R107	5135-8R2522	RES,CBN 1/2P 8.2
722	C113	5354-104593	CAP,MYL .1µ	702	R108	5135-103522	RES,CBN 1/2P 10K
719	C114	5361-220KSL	CAP,CER 22P	708	R109	5135-154522	RES,CBN 1/2P 150K
572	C201	5359-S010J102	CAP,PPP 1000P	703	R110	5135-123522	RES,CBN 1/2P 12K
573	C202	5359-S010J223	CAP,PPP .022µ	702	R111	5135-103522	RES,CBN 1/2P 10K
573	C203	5359-S010J223	CAP,PPP .022µ	708	R112	5135-154522	RES,CBN 1/2P 150K
574	C204	5354-474593	CAP,MYL .47µ	705	R113	5135-333522	RES,CBN 1/2P 33K
575	C205	5345-S06BM107	CAP,MINI ELE 100µ/10V	705	R114	5135-333522	RES,CBN 1/2P 33K
576	C206	5354-104593	CAP,MYL .1µ	706	△ R115	5102-4R75116	RES,FUSE 4.7
576	C207	5354-104593	CAP,MYL .1µ	706	△ R116	5102-4R75116	RES,FUSE 4.7
576	C208	5354-104593	CAP,MYL .1µ	698	R117	5135-101522	RES,CBN 1/2P 100
576	C209	5354-104593	CAP,MYL .1µ	699	R118	5135-471522	RES,CBN 1/2P 470
615	C301	5345-S06BM227	CAP,MINI ELE 220µ/10V	699	R119	5135-471522	RES,CBN 1/2P 470
615	C302	5345-S06BM227	CAP,MINI ELE 220µ/10V	703	R120	5135-123522	RES,CBN 1/2P 12K
615	C303	5345-S06BM227	CAP,MINI ELE 220µ/10V	703	R121	5135-123522	RES,CBN 1/2P 12K
615	C304	5345-S06BM227	CAP,MINI ELE 220µ/10V	704	R122	5135-223522	RES,CBN 1/2P 22K
613	C305	5353-820534	CAP,MCA 82P	704	R123	5135-223522	RES,CBN 1/2P 22K
613	C306	5353-820534	CAP,MCA 82P	701	R124	5135-102522	RES,CBN 1/2P 1K
612	C307	5353-330534	CAP,MCA 33P	701	R125	5135-102522	RES,CBN 1/2P 1K
612	C308	5353-330534	CAP,MCA 33P	695	R126	5135-2R7522	RES,CBN 1/2P 2.7
616	C309	5345-226C0951	CAP,MINI ELE 22µ/16V	702	R127	5135-103522	RES,CBN 1/2P 10K
616	C310	5345-226C0951	CAP,MINI ELE 22µ/16V	702	R128	5135-103522	RES,CBN 1/2P 10K
616	C311	5345-226C0951	CAP,MINI ELE 22µ/16V	709	R129	5232-100J16P	RES,CBN 1/6P 10
616	C312	5345-226C0951	CAP,MINI ELE 22µ/16V	717	R130	5232-273J16P	RES,CBN 1/6P 27K
611	C313	5353-100534	CAP,MCA 10P	712	R131	5232-103J16P	RES,CBN 1/6P 10K
611	C314	5353-100534	CAP,MCA 10P	715	R132	5232-333J16P	RES,CBN 1/6P 33K
636	C315	5359-5625851	CAP,PPP 5600P	715	R133	5232-333J16P	RES,CBN 1/6P 33K
636	C316	5359-5625851	CAP,PPP 5600P	717	R134	5232-273J16P	RES,CBN 1/6P 27K
635	C317	5359-1525851	CAP,PPP 1500P	714	R141	5232-223J16P	RES,CBN 1/6P 22K
635	C318	5359-1525851	CAP,PPP 1500P	563	R201	5232-472J16P	RES,CBN 1/6P 4.7K
632	C319	5345-227A0951	CAP,MINI ELE 220µ/6.3V	564	R202	5232-104J16P	RES,CBN 1/6P 100K
632	C320	5345-227A0951	CAP,MINI ELE 220µ/6.3V	564	R203	5232-104J16P	RES,CBN 1/6P 100K
635	C321	5359-1525851	CAP,PPP 1500P	562	R204	5232-471J16P	RES,CBN 1/6P 470
635	C322	5359-1525851	CAP,PPP 1500P	570	R205	5135-823522	RES,CBN 1/2P 82K
633	C323	5345-S06BM107	CAP,MINI ELE 100µ/10V	567	R206	5135-220522	RES,CBN 1/2P 22
633	C324	5345-S06BM107	CAP,MINI ELE 100µ/10V	568	R207	5135-271522	RES,CBN 1/2P 270
633	C325	5345-S06BM107	CAP,MINI ELE 100µ/10V	560	R208	5135-102522	RES,CBN 1/2P 1K
633	C326	5345-S06BM107	CAP,MINI ELE 100µ/10V	565	R209	5232-121J16P	RES,CBN 1/6P 120
544	C402	5345-S06FM106	CAP,MINI ELE 10µ/50V	569	R210	5135-472522	RES,CBN 1/2P 4.7K
542	C403	5345-S06BM107	CAP,MINI ELE 100µ/10V	566	R211	5232-222J16P	RES,CBN 1/6P 2.2K
543	C404	5345-476E0962	CAP,MINI ELE 47µ/35V	566	R212	5232-222J16P	RES,CBN 1/6P 2.2K
545	C405	5359-S010J103	CAP,PPP .01µ	571	R213	5135-222522	RES,CBN 1/2P 2.2K
545	C406	5359-S010J103	CAP,PPP .01µ	571	R214	5135-222522	RES,CBN 1/2P 2.2K
557	C407	5345-106C0951	CAP,MINI ELE 10µ/16V	571	R215	5135-222522	RES,CBN 1/2P 2.2K
641	C501	5345-S06BM107	CAP,MINI ELE 100µ/10V	571	R216	5135-222522	RES,CBN 1/2P 2.2K
641	C502	5345-S06BM107	CAP,MINI ELE 100µ/10V	571	R217	5135-222522	RES,CBN 1/2P 2.2K
675	C601	5359-1225851	CAP,PPP 1200P	577	R218	5135-102522	RES,CBN 1/2P 1K
675	C602	5359-1225851	CAP,PPP 1200P	595	R301	5135-220522	RES,CBN 1/2P 22
576	C603	5354-104593	CAP,MYL .1µ	595	R302	5135-220522	RES,CBN 1/2P 22
576	C604	5354-104593	CAP,MYL .1µ	595	R303	5135-220522	RES,CBN 1/2P 22
588	C701	5345-S06BM227	CAP,MINI ELE 220µ/10V	595	R304	5135-220522	RES,CBN 1/2P 22
587	C702	5345-S06FM106	CAP,MINI ELE 10µ/50V	603	R305	5135-103522	RES,CBN 1/2P 10K
587	C703	5345-S06FM106	CAP,MINI ELE 10µ/50V	603	R306	5135-103522	RES,CBN 1/2P 10K
589	C704	5353-050534	CAP,MCA 5P	603	R307	5135-103522	RES,CBN 1/2P 10K
589	C705	5353-050534	CAP,MCA 5P	603	R308	5135-103522	RES,CBN 1/2P 10K
586	C706	5345-S06BM107	CAP,MINI ELE 100µ/10V	603	R309	5135-103522	RES,CBN 1/2P 10K
586	C707	5345-S06BM107	CAP,MINI ELE 100µ/10V	603	R310	5135-103522	RES,CBN 1/2P 10K
				603	R311	5135-103522	RES,CBN 1/2P 10K
				603	R312	5135-103522	RES,CBN 1/2P 10K
				605	R313	5135-563522	RES,CBN 1/2P 56K

Ser. No.	Ref. No.	Part No.	Description
605	R314	5135-563522	RES,CBN 1/2P 56K
601	R315	5135-222522	RES,CBN 1/2P 2.2K
601	R316	5135-222522	RES,CBN 1/2P 2.2K
604	R317	5135-473522	RES,CBN 1/2P 47K
604	R318	5135-473522	RES,CBN 1/2P 47K
600	R319	5135-102522	RES,CBN 1/2P 1K
600	R320	5135-102522	RES,CBN 1/2P 1K
600	R321	5135-102522	RES,CBN 1/2P 1K
600	R322	5135-102522	RES,CBN 1/2P 1K
602	R323	5135-682522	RES,CBN 1/2P 6.8K
602	R324	5135-682522	RES,CBN 1/2P 6.8K
607	R325	5135-104522	RES,CBN 1/2P 100K
607	R326	5135-104522	RES,CBN 1/2P 100K
608	R327	5135-184522	RES,CBN 1/2P 180K
608	R328	5135-184522	RES,CBN 1/2P 180K
596	R329	5135-101522	RES,CBN 1/2P 100
596	R330	5135-101522	RES,CBN 1/2P 100
598	R331	5135-561522	RES,CBN 1/2P 560
598	R332	5135-561522	RES,CBN 1/2P 560
594	R333	5135-2R2522	RES,CBN 1/2P 2.2
594	R334	5135-2R2522	RES,CBN 1/2P 2.2
594	R335	5135-2R2522	RES,CBN 1/2P 2.2
594	R336	5135-2R2522	RES,CBN 1/2P 2.2
600	R337	5135-102522	RES,CBN 1/2P 1K
600	R338	5135-102522	RES,CBN 1/2P 1K
603	R339	5135-103522	RES,CBN 1/2P 10K
603	R340	5135-103522	RES,CBN 1/2P 10K
597	R341	5135-471522	RES,CBN 1/2P 470
597	R342	5135-471522	RES,CBN 1/2P 470
631	R343	5135-561522	RES,CBN 1/2P 560
631	R344	5135-561522	RES,CBN 1/2P 560
628	R345	5135-102522	RES,CBN 1/2P 1K
628	R346	5135-102522	RES,CBN 1/2P 1K
628	R347	5135-102522	RES,CBN 1/2P 1K
628	R348	5135-102522	RES,CBN 1/2P 1K
627	R349	5135-101522	RES,CBN 1/2P 100
627	R350	5135-101522	RES,CBN 1/2P 100
627	R351	5135-101522	RES,CBN 1/2P 100
627	R352	5135-101522	RES,CBN 1/2P 100
630	R353	5135-183522	RES,CBN 1/2P 18K
630	R354	5135-183522	RES,CBN 1/2P 18K
626	R355	5135-100522	RES,CBN 1/2P 10
626	R356	5135-100522	RES,CBN 1/2P 10
628	R357	5135-102522	RES,CBN 1/2P 1K
628	R358	5135-102522	RES,CBN 1/2P 1K
626	R361	5135-100522	RES,CBN 1/2P 10
626	R362	5135-100522	RES,CBN 1/2P 10
537	R401	5232-473J16P	RES,CBN 1/6P 47K
537	R402	5232-473J16P	RES,CBN 1/6P 47K
537	R403	5232-473J16P	RES,CBN 1/6P 47K
537	R404	5232-473J16P	RES,CBN 1/6P 47K
538	R405	5135-100522	RES,CBN 1/2P 10
540	R406	5135-331522	RES,CBN 1/2P 330
539	R407	5135-120522	RES,CBN 1/2P 12
539	R408	5135-120522	RES,CBN 1/2P 12
541	R409	5135-473522	RES,CBN 1/2P 47K
541	R410	5135-473522	RES,CBN 1/2P 47K
541	R411	5135-473522	RES,CBN 1/2P 47K
541	R412	5135-473522	RES,CBN 1/2P 47K
538	R414	5135-100522	RES,CBN 1/2P 10
642	R501	5135-220522	RES,CBN 1/2P 22
642	R502	5135-220522	RES,CBN 1/2P 22
644	R507	5135-103522	RES,CBN 1/2P 10K
644	R508	5135-103522	RES,CBN 1/2P 10K
643	R509	5135-560522	RES,CBN 1/2P 56
643	R510	5135-560522	RES,CBN 1/2P 56
671	R601	5135-123522	RES,CBN 1/2P 12K
671	R602	5135-123522	RES,CBN 1/2P 12K
673	R603	5135-105522	RES,CBN 1/2P 1M
673	R604	5135-105522	RES,CBN 1/2P 1M
672	R605	5135-154522	RES,CBN 1/2P 150K
581	R701	5135-121522	RES,CBN 1/2P 120
580	R702	5135-100522	RES,CBN 1/2P 10
584	R703	5232-472J16P	RES,CBN 1/6P 4.7K
582	R704	5135-101522	RES,CBN 1/2P 100
582	R705	5135-101522	RES,CBN 1/2P 100

INTEGRATED CIRCUITS

771	IC1	5653-M5290P	IC,LINEAR
681	IC101	5653-NJM4565D	IC,LINEAR
683	IC102	5653-BA6247N	IC,LINEAR
682	IC103	5653-LA6515	IC,LINEAR
561	IC201	5654-MN6626	IC,DIGITAL
531	IC401	5654-MN18724L	IC,DIGITAL
532	IC402	5654-T74HC04F	IC,DIGITAL
639	IC501	5653-NJM4565D	IC,LINEAR

Ser. No.	Ref. No.	Part No.	Description
578	IC701	5654-MN6471M	IC,DIGITAL
TRANSISTORS			
773	Q1	5614-2012	XISTOR,NPN A
772	Q2	5612-1375	XISTOR,PNP A
651	Q50	5613-C114ES	XISTOR,NPN R
652	Q51	5612-B114ES	XISTOR,PNP A
653	Q52	5613-2320L(F)	XISTOR,NPN R
685	Q101	5614-667(C)	XISTOR,NPN A
686	Q102	5612-647(C)	XISTOR,PNP A
688	Q103	5611-A124ES	XISTOR,PNP R
685	Q104	5614-667(C)	XISTOR,NPN A
689	Q105	5611-999L(F)	XISTOR,PNP R
687	Q106	5613-C124ES	XISTOR,NPN R
687	Q107	5613-C124ES	XISTOR,NPN R
591	Q301	5613-2320L(F)	XISTOR,NPN R
591	Q302	5613-2320L(F)	XISTOR,NPN R
592	Q303	5611-999L(F)	XISTOR,PNP R
592	Q304	5611-999L(F)	XISTOR,PNP R
591	Q305	5613-2320L(F)	XISTOR,NPN R
591	Q306	5613-2320L(F)	XISTOR,NPN R
592	Q307	5611-999L(F)	XISTOR,PNP R
592	Q308	5611-999L(F)	XISTOR,PNP R
592	Q309	5611-999L(F)	XISTOR,PNP R
592	Q310	5611-999L(F)	XISTOR,PNP R
591	Q311	5613-2320L(F)	XISTOR,NPN R
591	Q312	5613-2320L(F)	XISTOR,NPN R
621	Q313	5613-2320L(F)	XISTOR,NPN R
621	Q314	5613-2320L(F)	XISTOR,NPN R
622	Q315	5611-999L(F)	XISTOR,PNP R
622	Q316	5611-999L(F)	XISTOR,PNP R
623	Q317	5616-SK246GR2	FET,N-CH
623	Q318	5616-SK246GR2	FET,N-CH
533	Q401	5613-2320L(F)	XISTOR,NPN R
533	Q402	5613-2320L(F)	XISTOR,NPN R
533	Q403	5613-2320L(F)	XISTOR,NPN R
533	Q404	5613-2320L(F)	XISTOR,NPN R
534	Q405	5611-A124ES	XISTOR,PNP R
534	Q406	5611-A124ES	XISTOR,PNP R
534	Q407	5611-A124ES	XISTOR,PNP R
668	Q601	5616-SK246GR2	FET,N-CH
668	Q602	5616-SK246GR2	FET,N-CH
669	Q603	5612-B114ES	XISTOR,PNP A

DIODES

775 Δ	D1	5632-S5566B	DIODE,RECT
775 Δ	D2	5632-S5566B	DIODE,RECT
775 Δ	D3	5632-S5566B	DIODE,RECT
775 Δ	D4	5632-S5566B	DIODE,RECT
775 Δ	D5	5632-S5566B	DIODE,RECT
775 Δ	D6	5632-S5566B	DIODE,RECT
776	D7	5635-HZ5B-2	DIODE,ZENER
777	D8	5635-HZ27P-B	DIODE,ZENER
654	D50	5631-1S2473	DIODE,DET
662	D51	5631-1SS133	DIODE,DET
693	D101	5631-1S2473	DIODE,DET
690	D102	5635-HZ5C-2	DIODE,ZENER
690	D103	5635-HZ5C-2	DIODE,ZENER
694	D104	5635-HZ18-2L	DIODE,ZENER
691	D105	5635-HZ3B-2	DIODE,ZENER
692	D106	5635-HZ3C-2	DIODE,ZENER
693	D107	5631-1S2473	DIODE,DET
535	D409	5631-1SS133	DIODE,DET
670	D601	5631-1S2473	DIODE,DET
670	D602	5631-1S2473	DIODE,DET

MISCELLANEOUS

736	CN101	4443-05501022	CONNECTOR, 22 PIN
547	CN103	4443-0501140	CONNECTOR, 5 PIN
734	CN104	4443-0201140	CONNECTOR, 2 PIN
734	CN106	4443-0201140	CONNECTOR, 2 PIN
549	CN107	4443-0201140	CONNECTOR, 2 PIN
796	CN108	4443-0501140	CONNECTOR, 5 PIN
548	CN109	4443-0301140	CONNECTOR, 3 PIN
550	CN111	4443-05501030	CONNECTOR, 30 PIN
551	CN112	4443-05501022	CONNECTOR, 22 PIN
836	CN116	4443-030185	CONNECTOR, 3 PIN
836	CN117	4443-030185	CONNECTOR, 3 PIN
836	CN118	4443-030185	CONNECTOR, 3 PIN
836	CN119	4443-030185	CONNECTOR, 3 PIN
837	CN120	4443-070185	CONNECTOR, 7 PIN
549	CN121	4443-0201140	CONNECTOR, 2 PIN
836	CN122	4443-030185	CONNECTOR, 3 PIN
555	LCN102	4163-S0202451	CONNECTOR, W/W
655	RL50	4331-02001	RELAY,DC
842	W101	4132-R0102201	CORD,2C

Ser. No.	Ref. No.	Part No.	Description
839	W103	4242-R0104800	JUMPER LEAD, 5 WIRE
579	X701	5691-S0901343	XTAL, OSC, 33.8688MHZ
844	TM11-17	4214-132	TERMINAL (X7)

PCB-2 FRONT P. C. BOARD

CAPACITOR			
510	C401	5345-107B0356	CAP, MINI ELE 100µ/10V
RESISTOR			
509	R413	5135-100522	RES, CBN 1/2P 10
DIODES			
504	D401	5631-1S2473	DIODE, DET
504	D402	5631-1S2473	DIODE, DET
504	D403	5631-1S2473	DIODE, DET
504	D404	5631-1S2473	DIODE, DET
504	D405	5631-1S2473	DIODE, DET
504	D406	5631-1S2473	DIODE, DET
504	D407	5631-1S2473	DIODE, DET
504	D408	5631-1S2473	DIODE, DET
MISCELLANEOUS			
513	CN110	4443-05401012	CONNECTOR, 12 PIN
514	CN114	4443-05401030	CONNECTOR, 30 PIN
501	FL401	5722-055	TUBE DISPLAY, TRACK NO.
503	RC401	6143-00802	RECEIVER BLOCK, REMOTE SENSOR
506	SW401	4437-00610	PU-TC SWITCH, DISPLAY
506	SW402	4437-00610	PU-TC SWITCH, REPEAT
506	SW403	4437-00610	PU-TC SWITCH, RANDOM
506	SW404	4437-00610	PU-TC SWITCH, TIME
506	SW405	4437-00610	PU-TC SWITCH, STOP
506	SW406	4437-00610	PU-TC SWITCH, PLAY/PAUSE
506	SW407	4437-00610	PU-TC SWITCH, SEARCH FORWARD
506	SW408	4437-00610	PU-TC SWITCH, SEARCH BACK
506	SW409	4437-00610	PU-TC SWITCH, SKIP FORWARD
506	SW410	4437-00610	PU-TC SWITCH, SKIP BACK
506	SW411	4437-00610	PU-TC SWITCH, DISC SKIP

PCB-3 OUTPUT P. C. BOARD

CAPACITOR			
810	C901	5345-226C0962	CAP, MINI ELE 22µ/16V
RESISTORS			
806	R901	5232-101J16P	RES, CBN 1/6P 100
807	R902	5232-473J16P	RES, CBN 1/6P 47K
804	R903	5135-470522	RES, CBN 1/2P 47
805	R904	5135-331522	RES, CBN 1/2P 330
808	R905	5232-392J16P	RES, CBN 1/6P 3.9K
TRANSISTOR			
801	Q901	5611-A143ES	XISTOR, PNP R
MISCELLANEOUS			
835	Δ J301	4484-40	4P PIN JACK, OUTPUT FIXED/VARIABLE
812	J901	4451-00184	1P JACK, REMOTE IN
812	J902	4451-00184	1P JACK, REMOTE OUT
813	LCN109	4163-S0103301	CONNECTOR W/W, 3 PIN
802	PH901	5624-ON3161	PHOTO COUPLER
848	TM18	4214-132	TERMINAL

PCB-4 TABLE SENSOR P. C. BOARD

CAPACITOR			
751	C801	5345-476C0356	CAP, MINI ELE 47µ/16V
RESISTORS			
749	R802	5232-223J16P	RES, CBN 1/6P 22K
748	R803	5232-103J16P	RES, CBN 1/6P 10K
746	R804	5232-331J16P	RES, CBN 1/6P 330
746	R805	5232-331J16P	RES, CBN 1/6P 330
748	R806	5232-103J16P	RES, CBN 1/6P 10K
748	R807	5232-103J16P	RES, CBN 1/6P 10K
748	R808	5232-103J16P	RES, CBN 1/6P 10K
745	R809	5232-101J16P	RES, CBN 1/6P 100
747	R810	5232-472J16P	RES, CBN 1/6P 4.7K
750	R811	5232-104J16P	RES, CBN 1/6P 100K
750	R812	5232-104J16P	RES, CBN 1/6P 100K
TRANSISTORS			
742	Q801	5621-PT380F	PHOTO XISTOR

Ser. No.	Ref. No.	Part No.	Description
744	Q802	5613-2320L(F)	XISTOR, NPN R
MISCELLANEOUS			
753	LCN103	4163-S0105301	CONNECTOR W/W, 5 PIN
741	PH801	5624-GP1S53V	PHOTO COUPLER, SENSOR
741	PH802	5624-GP1S53V	PHOTO COUPLER, SENSOR

PCB-5 DISC SENSOR P. C. BOARD

RESISTOR			
755	R801	5135-331522	RES, CBN 1/2P 330
DIODE			
743	D801	5637-GL380	LED, SENSOR
MISCELLANEOUS			
756	CN102	4443-0201141	CONNECTOR

PCB-6 UP/DOWN SWITCH P. C. BOARD

MISCELLANEOUS			
552	LCN107	4163-S0102501	CONNECTOR W/W, 2 PIN
553	SW431	4438-00201	PU-MI SWITCH, UP/DOWN

PCB-7 VOLUME P. C. BOARD

CONTROL			
831	VR301	6161-00602	VR BLOCK 5K, (w/MVR), OUTPUT LEVEL

PCB-8 MOTOR P. C. BOARD

CAPACITOR			
718	C118	5359-S010J223	CAP, PPP .022µ
MISCELLANEOUS			
739	LCN106	4163-S0102301	CONNECTOR W/W, 2 PIN

PCB-9 POWER SWITCH P. C. BOARD

MISCELLANEOUS			
797	LCN108	4163-S0105141	CONNECTOR W/W, 5 PIN
834	SW1	4431-S0508102	PUSH SWITCH, POWER

PCB-10 HEADPHONES P. C. BOARD

CAPACITOR			
649	C505	5354-104593	CAP, MYL .1µ
MISCELLANEOUS			
648	J501	4451-51501	1P JACK, HEADPHONES
647	L501	5995-1R0J107	COIL W/CORE
647	L502	5995-1R0J107	COIL W/CORE
647	L503	5995-1R0J107	COIL W/CORE

PCB-11 TURN TABLE MOTOR P. C. BOARD

CAPACITOR			
724	C117	5359-S010J223	CAP, PPP .022µ
MISCELLANEOUS			
738	LCN104	4163-S0102251	CONNECTOR W/W, 2 PIN

PCB-12 DISC SELECT P. C. BOARD

MISCELLANEOUS			
520	CN113	4443-05401012	CONNECTOR, 12 PIN
519	SW412	4437-00610	PU-TC SWITCH, DISC 1
519	SW413	4437-00610	PU-TC SWITCH, DISC 2
519	SW414	4437-00610	PU-TC SWITCH, DISC 3
519	SW415	4437-00610	PU-TC SWITCH, DISC 4
519	SW416	4437-00610	PU-TC SWITCH, DISC 5
519	SW417	4437-00610	PU-TC SWITCH, PROGRAM/CONTINUE
519	SW418	4437-00610	PU-TC SWITCH, CHECK
519	SW419	4437-00610	PU-TC SWITCH, CLEAR

Ser. No. Ref. No. Part No. Description

PCB-13 10 KEY P. C. BOARD

MISCELLANEOUS

518	SW420	4437-00610	PU-TC SWITCH, TRACK +10
518	SW421	4437-00610	PU-TC SWITCH, TRACK 1
518	SW422	4437-00610	PU-TC SWITCH, TRACK 2
518	SW423	4437-00610	PU-TC SWITCH, TRACK 3
518	SW424	4437-00610	PU-TC SWITCH, TRACK 4
518	SW425	4437-00610	PU-TC SWITCH, TRACK 5
518	SW426	4437-00610	PU-TC SWITCH, TRACK 6
518	SW427	4437-00610	PU-TC SWITCH, TRACK 7
518	SW428	4437-00610	PU-TC SWITCH, TRACK 8
518	SW429	4437-00610	PU-TC SWITCH, TRACK 9
518	SW430	4437-00610	PU-TC SWITCH, TRACK 10

PCB-14 TOP FL P. C. BOARD

MISCELLANEOUS

522	CN115	4443-05501022	CONNECTOR, 22 PIN
517	FL402	5722-056	TUBE DISPLAY, DISC NO.

PCB-15 TRANS P. C. BOARD

MISCELLANEOUS

847	△T1	5584-S9301	XFORMER,POWER 3K
847B	△T1	5584-S9302	XFORMER,POWER 4W
845	△TM1	4214-122	TERMINAL 3K
845	△TM2	4214-122	TERMINAL 3K
845B	△TM3	4214-122	TERMINAL 3W
845B	△TM4	4214-122	TERMINAL 3W
838	W1	4242-R0207201	JUMPER LEAD, 7 WIRE

CHASSIS MISCELLANEOUS

MISCELLANEOUS

554	LCN121	4163-06209002	CONNECTOR W/W
840	LUG	4211-4	LUG, W508
735	M101	4311-40101	DC MOTOR, TABLE
833	△P1	4161-03601202	AC CORD W/PLUG, AC120V 3K
833B	△P1	4161-03701220	AC CORD W/PLUG, AC220V/240V WB
700	R142	5135-150522	RES,CBN 1/2P 15
025B	△SW101	4411-102729	ROTARY SWITCH, VOLTAGE SELECTOR WB
733	W103	4242-S0322201	JUMPER LEAD, 2 WIRE
733	W104	4242-S0322201	JUMPER LEAD
512	W110	4242-S0312251	JUMPER LEAD
546	W111	4242-S0330900	JUMPER LEAD
521	W112	4242-S0322201	JUMPER LEAD
846	W401	4242-R0104161	JUMPER LEAD, 8 WIRE
841	W402	4242-R0107161	JUMPER LEAD, 1 WIRE

ABBREVIATIONS IN PARTS LIST

CAPACITORS

CAP, MINI ELE	:Electrolytic
CAP, CER	:Ceramic
CAP, PPP	:Polypropylene
CAP, MYL	:Mylar
CAP, MTL	:Metal
CAP, MCA	:Mica
CAP, MINI BP	:Bipolar
CAP, ELE BP	:Electrolytic Bipolar
CAP, STY	:Polystyrene Film
CAP, SPE	:Special
CAP, TAN	:Tantalum
470μ	:470μF
6800p	:6800pF
.047μ	:0.047μF

RESISTORS

RES, CBN 1/6P	:Carbon 1/6W
RES, FUSE	:Fuse
RES, CEM 5P	:Cement 5W
RES, MTL 1P	:Metal 1W
2.2K	:2.2k Ω
220	:220 Ω

TRANSISTORS

XISTOR	:Transistor
FET	:Field Effect Transistor

CONTROLS

RES, V CBN	:Variable Carbon Resistor
RES, SEMI FIX	:Semi-fixed Resistor

NOTE



SAFETY RELATED COMPONENT. USE ONLY EXACT REPLACEMENT PART AS SPECIFIED.

PACKAGE

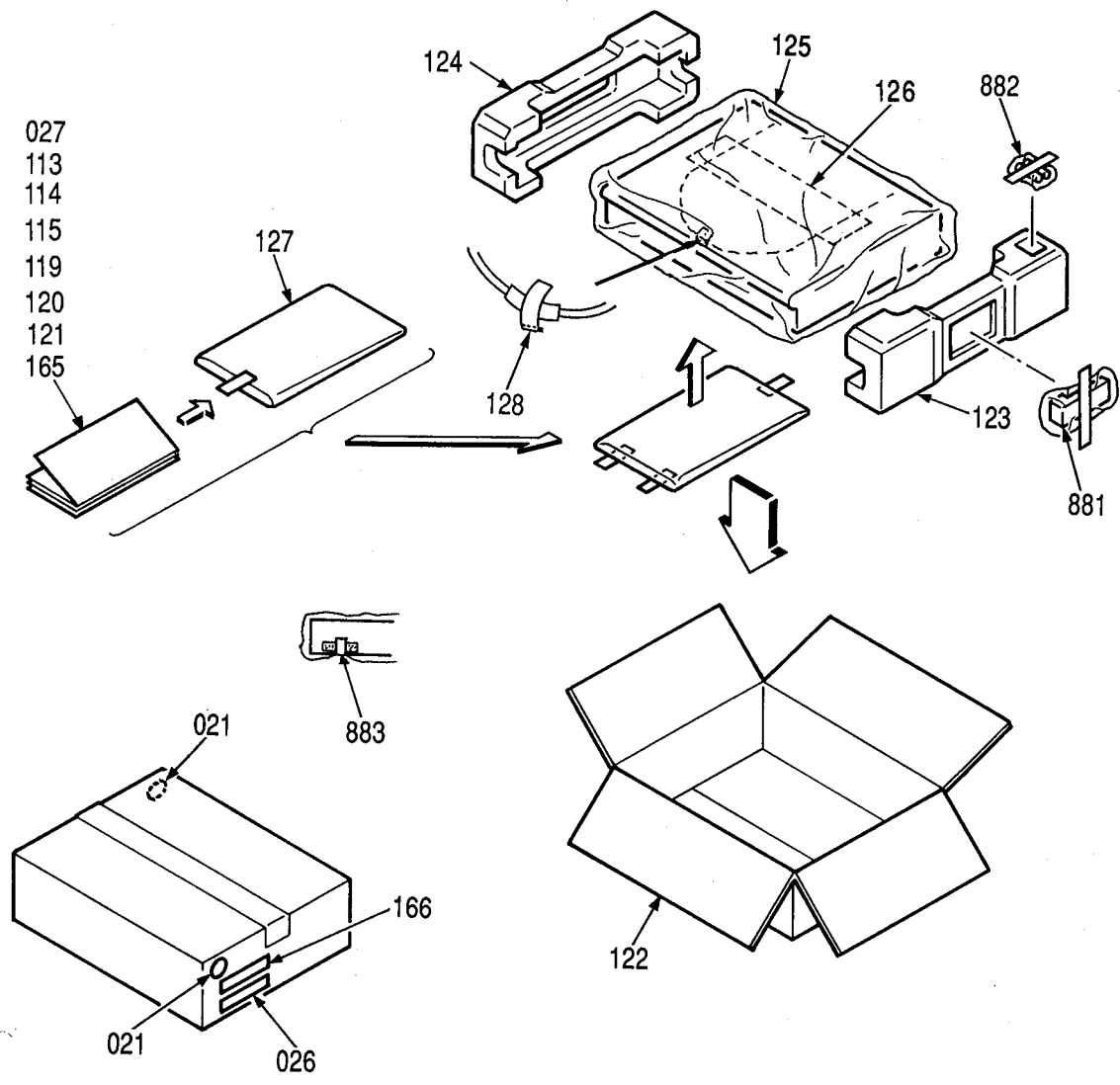

Ref. No.	Part No.	Description
021	1756-03101	LABEL (x2) WH
026	1756-06303	LABEL, VOLTAGE LABEL
027	1111-J30344	OWNER GUIDE, VOLTAGE SELECTOR WH
113	1111-J30343	OWNER GUIDE, IB BK
114	1119-01201	ATTACH SHEET, UL SAFETY BK
115	1113-02501	OWNER CARD BK
119	1116-03801	GUARANT CARD BK
120	1119-04301	ATTACH SHEET, SERVICE SHOP GUIDE BK
121	1119-04101	ATTACH SHEET
122	1221-29102	CARTON BOX
123	1222-7370	CUSHION, R
124	1222-7371	CUSHION, L
125	1222-1322	SOFT SHEET, SET
126	1223-R0115045	SOFT SHEET, DUST COVER
127	1241-R0123350	POLYETHY BAG, IB
128	1223-11749	SOFT SHEET, DUST COVER
165	1756-11601	LABEL, DHHS CARD BK
166	1756-11701	LABEL, DHHS CARD BK
881	6142-06801	CONT BLOCK
882	4191-0355	BATTERY, DRY
883	4161-71184	CORD W/PLUG, RCA TYPE

IC TERMINAL FUNCTIONS IN CD MECHANISM

IC101: AN8373S (Servo Amp.)

Terminal number	Port name	I/O	Outline of functions
1	AMPI	I	RF amp. input.
2	PDAD	I	Current input from PD.
3	PDA	I	
4	PDBD	I	
5	PDB	I	
6	LPD	I	
7	LD	O	LD-APC amp. output.
8	FBL ₁	I	Connect VR terminal for PD balance.
9	FBL ₂	I	
10	TBL ₁	I	
11	TBL ₂	I	
12	FOOFS	I	Connect VR terminal for focus offset.
13	IVA	O	Current/Voltage convert output (A).
14	IVB	O	Current/Voltage convert output (B).
15	FE	O	Focus error output.
16	FPI	I	Focus phase amp. input.
17	TPI	I	Tracking phase amp. input.
18	C-TPL	I	Connect capacitor terminal for tracking (low).
19	C-TPH	I	Connect capacitor terminal for tracking (high).
20	C-FPL	I	Connect capacitor terminal for focus (low).
21	C-FPH	I	Connect capacitor terminal for focus (high).
22	TPO	O	Tracking phase amp. output.
23	FPO	O	Focus phase amp. output.
24	FGC	I	Focus gain control (UP/Nor) input.
25	TGC	I	Tracking gain control (UP/Nor) input.
26	GD	I	Focus and tracking gain control (Down/Nor) input.
27	PTO	O	Potential detect amp. output.
28	PTI	I	Potential detect amp. input.
29	PBO	O	Potential detect buffer output.
30	POT	I	Potential detect buffer input.
31	BDO	O	BDO output.
32	RFDET	O	RF detect output.
33	SDO	O	System DO output.
34	C-sbdo	I	Connect detection capacitor for BDO detect.
35	ARF	O	RF signal output.
36	C-AGC	I	Connect capacitor for AGC loop phase.
37	V _{CC}	I	Power supply (typ+5V).
38	LDON	I	LD on/off select switch.
39	RF _{IN}	I	RF signal input.
40	AMPO	O	RF signal output.
41	V _{REF}	O	Voltage output for servo amp.
42	G _{ND}	I	GND.

IC102: AN8374S (Servo Control)

Terminal number	Port name	I/O	Outline of functions
1	LSA	I	1-beam phase difference signal input. (A)
2	LSB	I	1-beam phase difference signal input. (B)
3	TE OFS	O	Offset adj. terminal for tracking servo.
4	TE	O	Tracking error voltage output.
5	TEG	I	SW-Buff input for tracking servo.
6	TE OUT	O	SW-Buff output for tracking servo.
7	TE BPF	I	Window comparator input.
8	FEG	I	Focus servo input.
9	FE.OUT	O	Focus servo amp. output.
10	C.LW	I	Focus servo search oscillation terminal.
11	Vref	I	Vref input.
12	ARF	I	RF signal input.
13	C.DSL	I	Connect loop filter of auto slice level control.
14	FPC	I	PLL frequency input.
15	GND	I	GND.
16	C.PLL	I	Connect PLL loop filter.
17	VSS	I	GND.
18	CLK	I	Clock input. 88.2kHz
19	SRF	O	PCK synchronous ARF digital signal output.
20	PCK	O	Clock output.
21	EFM	O	EFM signal output.
22	V _{DD}	I	Power supply.
23	SPCNT	O	Track cross speed control output.
24	SENSE	O	CROSS, SCROSS and OFTR output.
25	TRV F/R	O	Traverse output.
26	FLOCK	O	RFDET output.
27	KICK	O	Track jump control signal output.
28	LDON	O	LDON signal output.
29	VDET	O	When oscillation detecting, output level to H.
30	CNT1	I	Control input (FOON : Focus servo)
31	CNT2	I	Control input (TRON : Tracking servo)
32	CNT3	I	Control input (KICKF : Kick)
33	CNT4	I	Control input (KICKR : Kick)
34	TRV F	I	Servo mode of traverse select. forward side.
35	TRV R	I	Servo mode of traverse select. reverse side.
36	RFDET	I	RF DET interface input.
37	BDO	I	BDO input.
38	V _{CC}	I	Power supply.
39	TRVO	O	TRV amp. output.
40	TRVI	I	TRV amp. reverse input.
41	BROUT	O	Break circuit output.
42	BRIN	I	Break circuit input.

IC103: AN8377N (3-channel Lenear Driver)

Terminal number	Port name	I/O	Outline of functions
1	PV _{CC}	I	Power supply for power transistors.
2	V _{CC}	I	Power supply.
3	TB	O	Connect base of external transistor (PNP).
4	V _{MON}	O	Connect collector of external transistor (PNP).
5	TVDI	I	Traverse error input.
6	FDI	I	Focus error input.
7	TDI	I	Tracking error input.
8	V _{REF}	I	V _{REF} input.
9	TD-	O	Tracking BTL driver reverse output.
10	TD+	O	Tracking BTL driver output.
11	FD-	O	Focus BTL driver reverse output.
12	FD+	O	Focus BTL driver output.
13	TVD-	O	Traverse BTL driver reverse output.
14	TVD+	O	Traverse BTL driver output.
15	RESET	O	Reset output.
16	PC	I	Power cut input.

IC TERMINAL FUNCTIONS

IC201: MN6626 (Digital Signal Processor)

Terminal number	Port name	I/O	Outline of functions
1	AVSS	I	GND (0V) for DSL and PLL circuits.
2	IREF	I	Standard current input.
3	ARF	I	RF signal input.
4	DRF	I	Bias terminal for DSL.
5	DSL F	O	Loop filter terminal for DSL.
6	PLL F	I/O	Loop filter terminal for PLL.
7	AVDD	I	Power supply (+5V) for DSL and PLL.
8	RSEL	I	RF signal polarity select.
9	TBUS7	O	Test terminal. (Common: open)
10	TBUS6	O	Test terminal. (Common: open)
11	TBUS5	O	Test terminal. (Common: open)
12	TBUS4	O	Test terminal. (Common: open)
13	TBUS3	O	Test terminal. (Common: open)
14	TBUS2	O	Test terminal. (Common: open)
15	TBUS1	O	Test terminal. (Common: open)
16	TBUS0	O	Test terminal. (Common: open)
17	FLAG	O	Flag output.
18	IPFLAG	O	Interpolation flag. H: Interpolation
19	FCLK	O	Crystal frame clock. 7.35kHz
20	BYTCK	O	Byte clock.
21	WDCK	O	Word clock.
22	/RST	I	Reset input.
23	TX	O	Digital audio interface output signal.
24	LDG	O	L ch deglitch signal.
25	RDG	O	R ch deglitch signal.
26	SRDATA	O	Serial data output.
27	SCK	O	Bit clock for SRDATA.
28	LRCK	O	L ch and R ch discriminate signal.
29	XCK	O	Crystal oscillator clock output. 16.9344MHz
30	PMCK	O	1/192 divider clock signal. 88.2kHz
31	CSEL	I	Test terminal. (Common: low level)
32	PSEL	I	Test terminal. (Common: low level)
33	X1	I	Crystal oscillator input. 16.9344MHz
34	X2	O	Crystal oscillator output. 16.9344MHz
35	VSS	I	Power supply (0V).
36	SUBQ	O	Subcode Q code output.
37	SQCK	I	Subcode Q register clock output.
38	/CLDCK	O	Subcode frame clock signal. 7.35kHz
39	BLKCK	O	Subcode block clock signal. 75Hz
40	DEMPH	O	De-emphasis signal. H: on
41	MEMP	I	Emphasis input for digital audio interface.
42	MLD	I	μ -com command load input. L: load
43	MCLK	I	μ -com command clock input.
44	MDATA	I	μ -com command data input.
45	DMUTE	I	Muting input. H: mute
46	SMCK	O	MSEL=H: 1/2 divider clock signal. 8.4672MHz MSEL=L: 1/4 divider clock signal. 4.239MHz
47	STAT	O	Status signal.
48	CRC	O	Subcode CRC check result output.
49	SUBC	O	Subcode serial output data.
50	SBCK	I	Clock input for SUBC.
51	/TRON	I	Tracking servo ON signal. L: ON
52	CLVS	O	Spindle servo phase synchronous signal.
53	PC	O	Spindle motor ON signal. L: ON
54	ECM	O	Spindle motor drive signal.
55	ECS	O	Spindle motor drive signal.
56	VDD	I	Power supply (+5V).
57	/TEST	I	Test terminal. (Common: low level)
58	SSEL	I	SUBQ terminal. Output mode select.
59	MSEL	I	SMCK terminal. Output frequency select.
60	RESY	O	Frame synchronous signal.
61	DO	I	Drop out signal.
62	EFM	O	EFM signal output.
63	PCK	O	PLL clock output. 4.3218MHz
64	PDO	O	Phase compare EFM with PCK.

IC401: MN187124L (Microcomputer)

Terminal number	Port name	I/O	Outline of functions
1	VDD	I	Power supply (+5V).
2	OSC2	O	System clock output.
3	OSC1	I	System clock input. 4.23MHz
4	VSS	I	GND
5	XI	I	NC
6	XO	O	NC
7	VIN2	I/O	System reset output.
8	CNT1	I/O	Servo mode output 1.
9	CNT2	I/O	Servo mode output 2.
10	FLOCK	I/O	RF detector input.
11	CNT3	I/O	Servo mode output 3.
12	CNT4	I/O	Servo mode output 4.
13	TRV-F	I/O	Traverse servo mode output 1.
14	TRV-R	I/O	Traverse servo mode output 2.
15	REMO	I	Remote control input.
16	BLKCK	I	Subcode block clock signal. 75Hz
17	MCLK	I/O	μ -com command clock signal.
18	MLD	I/O	μ -com command load signal.
19	BUZZER	I/O	μ -com command data signal.
20	SENSE	I/O	Servo signal.
21	RST	I/O	μ -com reset signal input. L: reset
22	DMUTE	I/O	DSP mute signal. L: mute
23	STAT	I/O	Status signal.
24	VOLUP/DOWN	I/O	Volume up/down 3 state output.
25	SQCK	I/O	Subcode Q register result clock.
26	SUBQ	I/O	Subcode Q code input.
27	SBOO	I/O	NC
28	SYNC	O	NC
29	CM	I	GND
30	POS	I/O	Photo sensor input. (Position det.)
31	DNO	I/O	Photo sensor input. (Disc number det.)
32	DCHK	I/O	Photo sensor input. (Disc det.)
33	KEY4	I/O	Key input.
34	KEY3	I/O	Key input.
35	KEY2	I/O	Key input.
36	KEY1	I/O	Key input.
37	KEY0	I/O	Key input.
38	G10	O	Display output. Key scan output.
39	G9	O	Display output. Key scan output.
40	G8	O	Display output. Key scan output.
41	G7	O	Display output. Key scan output.
42	G6	O	Display output. Key scan output.
43	G5	O	Display output. Key scan output.
44	G4	O	Display output. Key scan output.
45	G3	O	Display output. Key scan output.
46	G2	I/O	Display output.
47	G1	I/O	Display output.
48		I/O	Loading motor out
49		I/O	Loading motor in
50	SPEED	I/O	Disc table rotate signal. H: low rotate
51	MCON2	I/O	Disc table up/down control signal.
52	MCON1	I/O	Disc table up/down control signal.
53	k	I/O	Display output.
54	j	I/O	Display output.
55	i	I/O	Display output.
56	h	O	Display output.
57	g	O	Display output.
58	f	O	Display output.
59	e	O	Display output.
60	d	O	Display output.
61	c	O	Display output.
62	b	O	Display output.
63	a	O	Display output.
64	Vpp	I	Negative power supply.

IC701: MN6471M (Digital Filter & D/A Converter)

Terminal number	Port name	I/O	Outline of functions
1	MLD	I	μ -com command load input. (L: load)
2	RSTB	I	Reset terminal. (L: reset)
3	IE	I	L: DSP format. H: FS format.
4	TP1	O	Digital filter test output 1.
5	TP2	O	Digital filter test output 2.
6	TEST1	I	Digital filter test input 1. (Common: low level)
7	TEST2	I	Digital filter test input 2. (Common: low level)
8		—	NC
9		—	NC
10	AV _{DD4}	I	Analog power supply 4 (+5V).
11	OUTL(-)	O	Negative L ch PWM output.
12	AV _{SS4}	I	Analog GND terminal 4.
13	AV _{SS3}	I	Analog GND terminal 3.
14	OUTL(-)	O	Positive L ch PWM output.
15	AV _{DD3}	I	Analog power supply 3 (+5V).
16		—	NC
17	AV _{DD2}	I	Analog power supply 2 (+5V).
18	OUTR(+)	O	Positive R ch PWM output.
19	AV _{SS2}	I	Analog GND terminal 2.
20	AV _{SS1}	I	Analog GND terminal 1.
21	OUTR(-)	O	Positive R ch PWM output.
22	AV _{DD1}	I	Analog power supply 1 (+5V).
23	DV _{DD1}	I	Digital power supply 1 (+5V) for OSC.
24	DV _{SS1}	I	Digital GND 1 for OSC.
25	X2	O	Crystal oscillator.
26	X1	I	Crystal oscillator. (Clock input)
27		—	NC
28	DV _{DD2}	I	Digital power supply 2 (+5V).
29	DV _{SS2}	I	Digital GND 2.
30	NSUB	I	Connect to D-V _{DD} .
31	ZFLGB	O	Zero detect output. L: zero
32	192fs	O	192fs output. 8.4672MHz
33	LRPOL	I	LRCLK polarized select.
34	LRCLK	I	LRCLK input. When LR-POL is high level; H: L ch data input. L: R ch data input. When LR-POL is low level; H: R ch data input. L: L ch data input.
35	BCLK	I	Serial input bit clock.
36	SRDATA	I	Serial data (digital) input.
37	DV _{SS3}	I	Digital GND 3.
38	DV _{DD}	I	Digital power supply (+5V).
39	384fs	O	384fs output. 16.9344MHz
40	PD	I	Power down. H: power down mode
41	MDATA	I	μ -com command data input.
42	MCLK	I	μ -com command clock input.

INFRARED REMOTE CONTROL SCHEMATIC DIAGRAM

No.	FUNCTION	No.	FUNCTION
K2	F-SKIP	K21	2
K3	INDEX FWD	K22	6
K4	SPACE	K23	10
K5	+10	K24	VOLUM ^
K6	4	K25	R-SEARCH
K7	8	K26	A-B
K8	TIME	K27	CLEAR
K9	STOP	K28	3
K10	R-SKIP	K29	7
K11	INDEX REV	K30	CHECK
K12	INTRO	K31	VOLUM V
K13	1	K32	DISC SKIP
K14	5	K33	DISC # 4
K15	9	K34	RANDOM
K16	DISPLAY	K35	DISC # 1
K17	PLAY/PAUSE	K36	DISC # 5
K18	F-SEARCH	K37	DISC # 2
K19	REPEAT	K38	DISC # 3
K20	PROG/CONT		

