

The Harman Kardon Model TU909

Manual 139A

DIGITAL SYNTHESIZED QUARTZ-LOCKED TUNER

TU909

Technical Manual

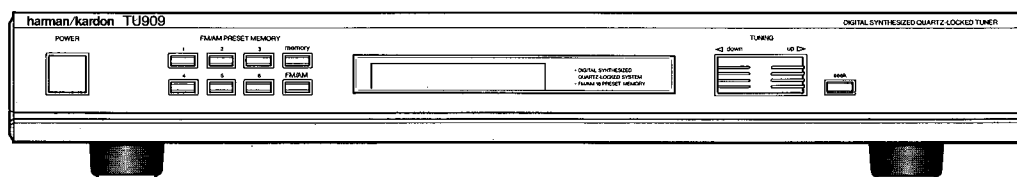

The following marks found in the parts list of this manual identify the models as follows.

- BK : North America area model Black version
- GB : General model Black version
- BB : Australia model Black version

harman/kardon

240 Crossways Park West, Woodbury, N. Y. 11797
1112-3152139A2 P-088809 1500 Printed in Japan

SPECIFICATIONS

	Nominal	Limit
• FM SECTION		
Tuning Range	87.5 ~ 108.0 MHz	
50dB Quieting Sensitivity		
Mono	15.2dBf \leq 19dBf	
Stereo	37.2dBf \leq 41dBf	
Usable Sensitivity	10.7dBf \leq 15dBf	
Image Ratio	45dB \geq 38dB	
IF Rejection	87dB \geq 70dB	
Spurious Response Rejection	78dB \geq 60dB	
Capture Ratio	1.5dB \geq 2dB	
Alternate Channel Selectivity	76dB \geq 60dB	
AM Rejection	59dB \geq 45dB	
Signal to Noise Ratio		
Mono	80dB \geq 75dB	
Stereo	73dB \geq 68dB	
Total Harmonic Distortion		
Mono	0.09% \leq 0.3%	
Stereo	0.07% \leq 0.4%	
Stereo Separation at 1 kHz	42dB \geq 35dB	
Output Level/Impedance (Stereo)	790mV/2.2k Ω	

	Nominal	Limit
• AM SECTION		
Tuning Range		
North America area model	530 ~ 1,620kHz	
General and Australia models	531 ~ 1,602kHz	
Usable Sensitivity		
External Antenna	14 μ V \leq 20 μ V	
Loop Antenna	350 μ V/m	
Selectivity	29dB \geq 25dB	
Signal to Noise Ratio	53dB \geq 48dB	
Image Rejection	40dB \geq 30dB	
IF Rejection	67dB \geq 50dB	
• DIMENSION		
(W x H x D)	17-7/16" x 2-11/16" x 14-3/16" (443 x 68 x 360 mm)	
• WEIGHT		
	7.3 lbs. (3.3 kg)	
• POWER SUPPLIES		
for North America area model	AC 120V, 60Hz	
for General and Australia models	AC 220/240V, 50/60Hz	
• POWER CONSUMPTION		
	10W	

These specifications are service target specs.

Specifications and components subject to change without notice. Overall performance will be maintained or improved.

LEAKAGE TEST (FOR SERVICE ENGINEERS IN THE U.S.A.)

Before returning the unit to the user, perform the following safety checks:

- Inspect all lead dress to make certain that leads are not pinched or that hardware is not lodged between the chassis and other metal parts in the unit.
- Be sure that any protective devices such as nonmetallic control knobs, insulating fishpapers, cabinet backs, adjustment and compartment covers or shields, isolation resistor-capacity networks, mechanical insulators, etc. which were removed for servicing are properly reinstalled.
- Be sure that no shock hazard exists; check for leakage current using Simpson Model 229 Leakage Tester, standard equipment item No. 21641, RCA Model WT540A or use alternate method as follows: Plug the power cord directly into a 120-volt AC receptacle (do not use an Isolation Transformer for this test). Using two clip leads, connect a 1500 Ohm, 10-watt resistor paralleled by a 0.15 μ F capacitor, in series with all exposed metal cabinet parts and a known earth ground, such as a water pipe or conduit. Use a VTVM or VOM with 1000 Ohms per volt, or higher sensitivity to measure the AC voltage drop across the resistor. (See Diagram.) Move the resistor connection to each exposed metal part having a return path to the chassis (antenna, metal, cabinet, screw heads, knobs and control shafts, escutcheon, etc.) and measure the AC voltage drop across the resistor. (This test should be performed with the power switch in both the On and Off positions.)

A reading of 0.35 volt RMS or more is excessive and indicates a potential shock hazard which must be corrected before returning the unit to the owner.

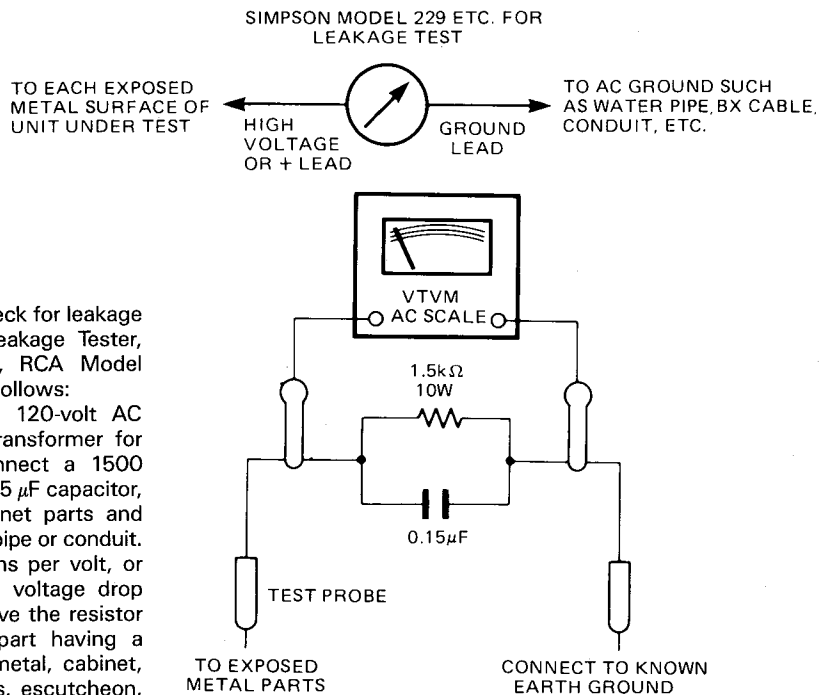

DISASSEMBLY PROCEDURES (REFER TO PAGES 5,6 AND 12)

① CABINET TOP REMOVAL

Remove 5 screws (A) and then remove the Cabinet Top (127).

② FRONT PANEL ASS'Y (AA) REMOVAL

1. Remove the Cabinet Top (127), referring to the previous step ①.
2. Remove 5 screws (B) and then remove the Front Panel Ass'y (AA).

③ MAIN P. C. BOARD (PCB-1) REMOVAL

1. Remove the Front Panel Ass'y (AA), referring to the previous step ②.
2. Disconnect the lead wire (JL1) from CN5 on the Main P. C. Board (PCB-1).
3. Remove 8 screws (C) and pull the Main P. C. Board (PCB-1) forward with the PCB-3 and PCB-4.
4. Disconnect the connectors from CN3 of PCB-3 and CN4 of PCB-4 on the Main P. C. Board.

ALIGNMENT PROCEDURES (REFER TO PAGES 10, 11, 17 AND 18)

■ AM ADJUSTMENT

Conditions : • Make the adjustment at a room temperature of 77°F (25°C).

- Set the AM mode by pressing the "FM/AM" button.
- Standard modulation of the AM signal generator is 400Hz at 30%.
- Set the Seek switch to off (put out seek indicator) position.

* General and Australia models

Step	Alignment	Connection Equipments	Measurement Frequency	Station Display	Adjustment	For
1	IF	<ul style="list-style-type: none"> • Connect the AM Test Loop Antenna cable into the output jack of AM Signal Generator. Place AM Test Loop Antenna close enough to couple signal into the AM Loop Antenna. • Connect the VTVM and oscilloscope to the OUTPUT jacks. 	1400kHz *1404kHz	1400kHz *1404kHz	T252	Maximum output level and symmetrical curve on scope.
2	Tracking		1400kHz *1404kHz	1400kHz *1404kHz	TC251	Maximum output.
3			600kHz *603kHz	600kHz *603kHz	T251	Maximum output.
4			Repeat steps 2 and 3 for optimum sensitivity.			

■ FM ADJUSTMENT

Conditions : • Set the FM mode by pressing the "FM/AM" button.

- Set the Seek switch to off (put out seek indicator) position.

	North America model	General and Australia models
FM Signal Generator	1kHz, 100% modulation	1kHz, 45% modulation
Stereo Modulator	L + R = 45.5%, L - R = 45.5%, 19kHz = 9%	L + R = 22.5%, L - R = 22.5%, 19kHz = 8%

Step	Alignment	Connection Equipments	Measurement Frequency	Station Display	Adjustment	For
1	Discriminator	<ul style="list-style-type: none"> • Connect the FM Signal Generator to FM 300Ω BAL Antenna terminals through the 300Ω balanced dummy. [1mV(65dBf) input signal] • Connect the Oscilloscope and Distortion meter to the OUTPUT jacks. • Set the Seek switch to on (seek indicator lights) position. 	97.9MHz	97.9MHz	T201(A)	Adjust T201 (A) so that the voltage across the terminal of R217 come to DC 0V ± 20mV.
2			97.9MHz	97.9MHz	T201(B)	Minimum distortion.
3			Repeat steps 1 and 2 for optimum sensitivity.			
4	Muting level		97.9MHz	97.9MHz	VR251	Adjust VR251 so that the waveform is disappear at 35 dBf input.
5	Separation	<ul style="list-style-type: none"> • Connect the Stereo Modulator to FM Signal Generator. Connect the FM Signal Generator to FM 300Ω BAL Antenna terminal through the 300Ω balanced dummy. [1mV (65 dBf) input signal] • Connect the VTVM and Oscilloscope to the OUTPUT jacks. 			VR301	Adjust so that the left channel output becomes minimum when only the right channel of the Stereo Modulator is modulated.
			97.9MHz	97.9MHz	VR301	Adjust so that the right channel output becomes minimum when only the left channel of the Stereo Modulator is modulated.

CIRCUIT DESCRIPTION

■ FM TUNER SECTION

The FM signal which has entered through the antenna is high-frequency amplified in the front end unit FE101, mixed with the output of the local oscillator and converted into the 10.7MHz intermediate-frequency.

The 10.7MHz signal is amplified in the intermediate-frequency amplifying section which consists of CF201, Q201, CF202, Q202 and CF203 and fed to pin 1 of IC201. In IC201, the signal is transmitted through the IF amplifier in two steps, and after being detected in the quadrature, it is transmitted through the post amplifier to pin 12 and then input to pin 2 of IC301. In IC301, the pilot signal is detected out of the signal which has been fed and 38kHz signal is produced. Then by this signal, stereo signal is demodulated, output from pin 4 for the left channel and from pin 7 for the right channel be fed to the amplifier.

■ AM TUNER SECTION

The AM signal which has entered through the antenna is transmitted through the tuning circuit consisting of T251 and TC251 to IC201. In IC201 it undergoes high-frequency amplification, intermediate-frequency amplification local oscillation, intermediate-frequency amplification and detection, and then output from pin 15. This signal is turned ON and OFF at Q703 and Q704 according to the signal from the input selector and fed to pin 2 of IC301.

■ MUTING CIRCUIT

If FM is received out of tuning or in a very weak field intensity, pin 41 of IC701 becomes high level. This is fed to the base of Q706, whose collector then becomes low level and the collector of Q708 high level. As a result, Q301 (R ch) and Q302 (L ch) are conducted to mute the output.

■ SYNTHESIZER SECTION

● FM

The local oscillation output at the front end is fed to pin 15 of IC702 and after being frequency divided into 30 or 32, the standard frequency is oscillated by the crystal oscillator, compared with the divided local oscillation output signal and output to pin 10. This voltage is level converted at Q701 and Q702, and fed to the varicap diode at the front end.

● AM

The local oscillation output is fed from pin 24 of IC201 to pin 13 of IC702. In IC702, the standard frequency is oscillated by the crystal oscillator, compared with the local oscillation output and output to pin 10.

■ INDICATOR SECTION

● Frequency display

The serial data sent out of pins 1 to 22, 54 and 57 to 60 of IC701, where the data is decoded to provide a signal which turns ON the indicator.

BLOCK DIAGRAM

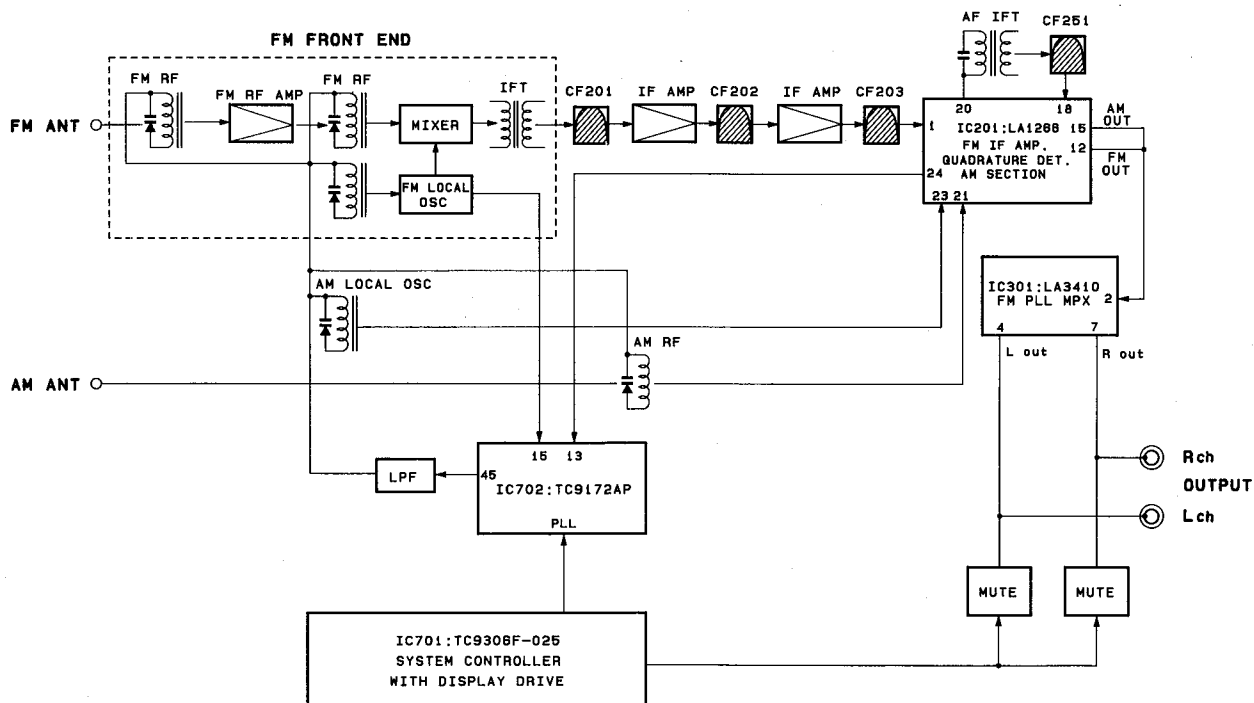

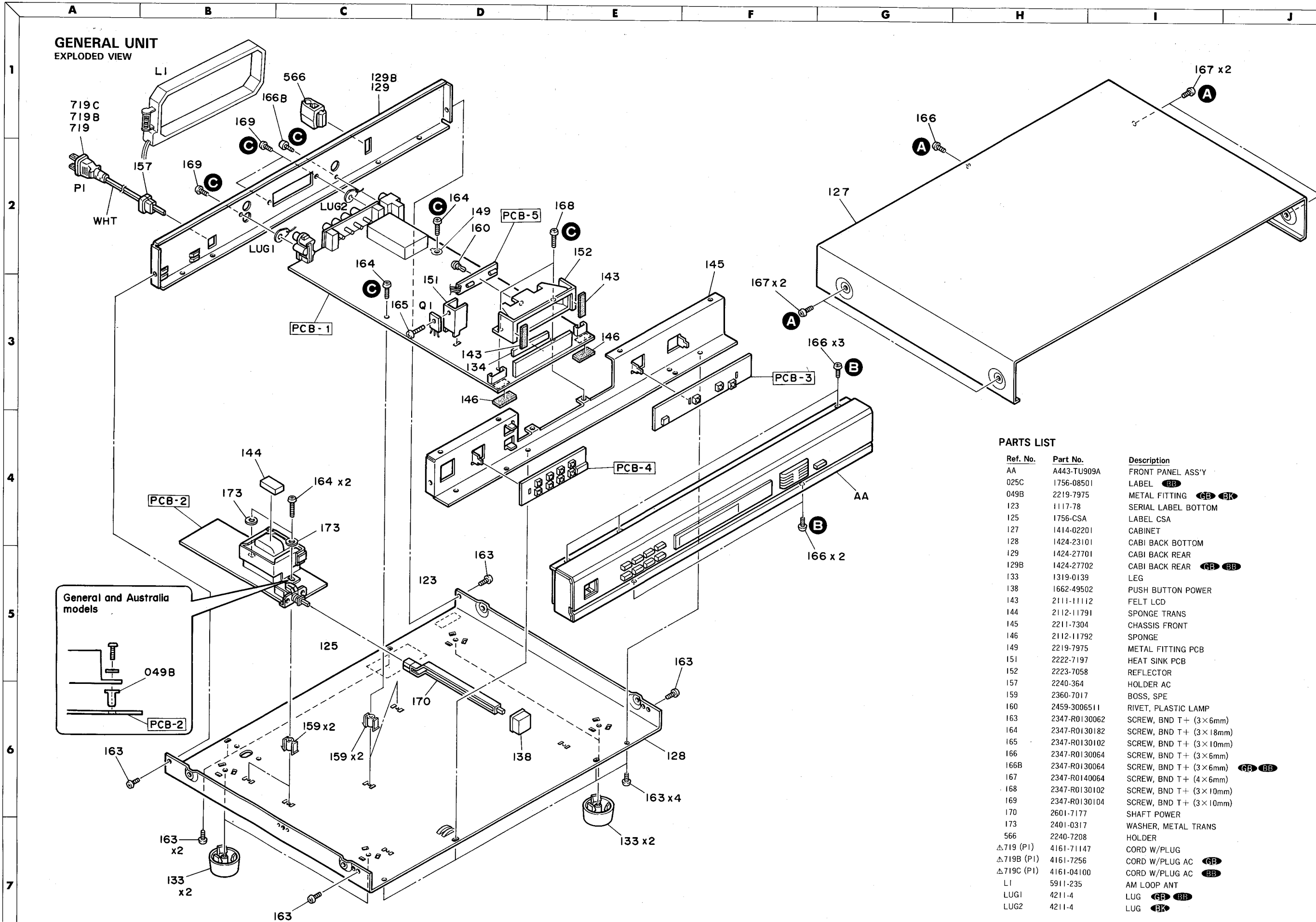

PARTS LIST

Ref. No.	Part No.	Description
AA	A443-TU909A	FRONT PANEL ASS'Y
025C	1756-08501	LABEL BB
049B	2219-7975	METAL FITTING GB BK
123	1117-78	SERIAL LABEL BOTTOM
125	1756-CSA	LABEL CSA
127	1414-02201	CABINET
128	1424-23101	CABI BACK BOTTOM
129	1424-27701	CABI BACK REAR
129B	1424-27702	CABI BACK REAR GB BB
133	1319-0139	LEG
138	1662-49502	PUSH BUTTON POWER
143	2111-11112	FELT LCD
144	2112-11791	SPONGE TRANS
145	2211-7304	CHASSIS FRONT
146	2112-11792	SPONGE
149	2219-7975	METAL FITTING PCB
151	2222-7197	HEAT SINK PCB
152	2223-7058	REFLECTOR
157	2240-364	HOLDER AC
159	2360-7017	BOSS, SPE
160	2459-3006511	RIVET, PLASTIC LAMP
163	2347-R0130062	SCREW, BND T+ (3x6mm)
164	2347-R0130182	SCREW, BND T+ (3x18mm)
165	2347-R0130102	SCREW, BND T+ (3x10mm)
166	2347-R0130064	SCREW, BND T+ (3x6mm)
166B	2347-R0130064	SCREW, BND T+ (3x6mm) GB BB
167	2347-R0140064	SCREW, BND T+ (4x6mm)
168	2347-R0130102	SCREW, BND T+ (3x10mm)
169	2347-R0130104	SCREW, BND T+ (3x10mm)
170	2601-7177	SHAFT POWER
173	2401-0317	WASHER, METAL TRANS
566	2240-7208	HOLDER
△719 (P1)	4161-71147	CORD W/PLUG
△719B (P1)	4161-7256	CORD W/PLUG AC GB
△719C (P1)	4161-04100	CORD W/PLUG AC BB
L1	5911-235	AM LOOP ANT
LUG1	4211-4	LUG GB BB
LUG2	4211-4	LUG BK

GENERAL UNIT
EXPLODED VIEW

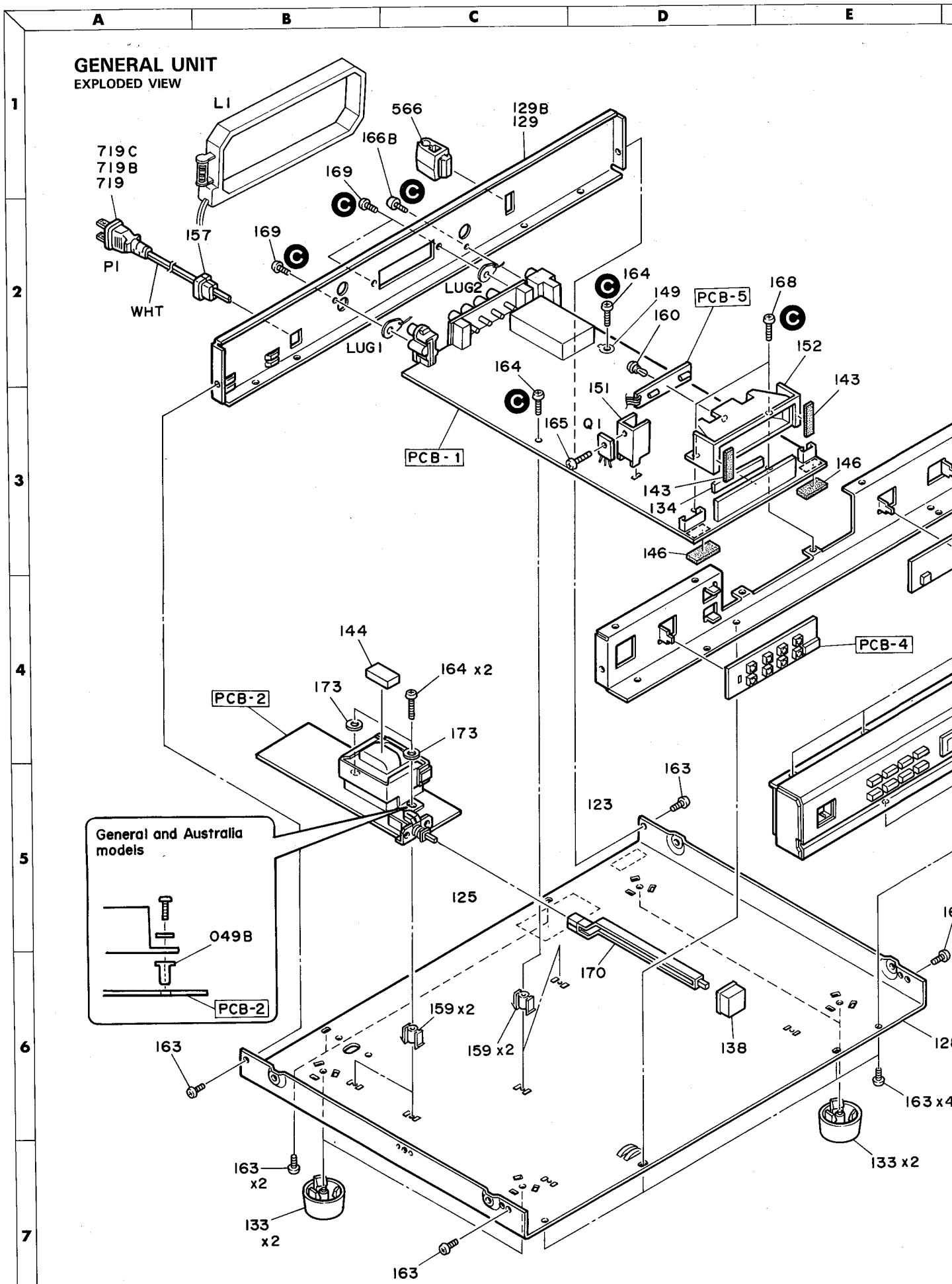

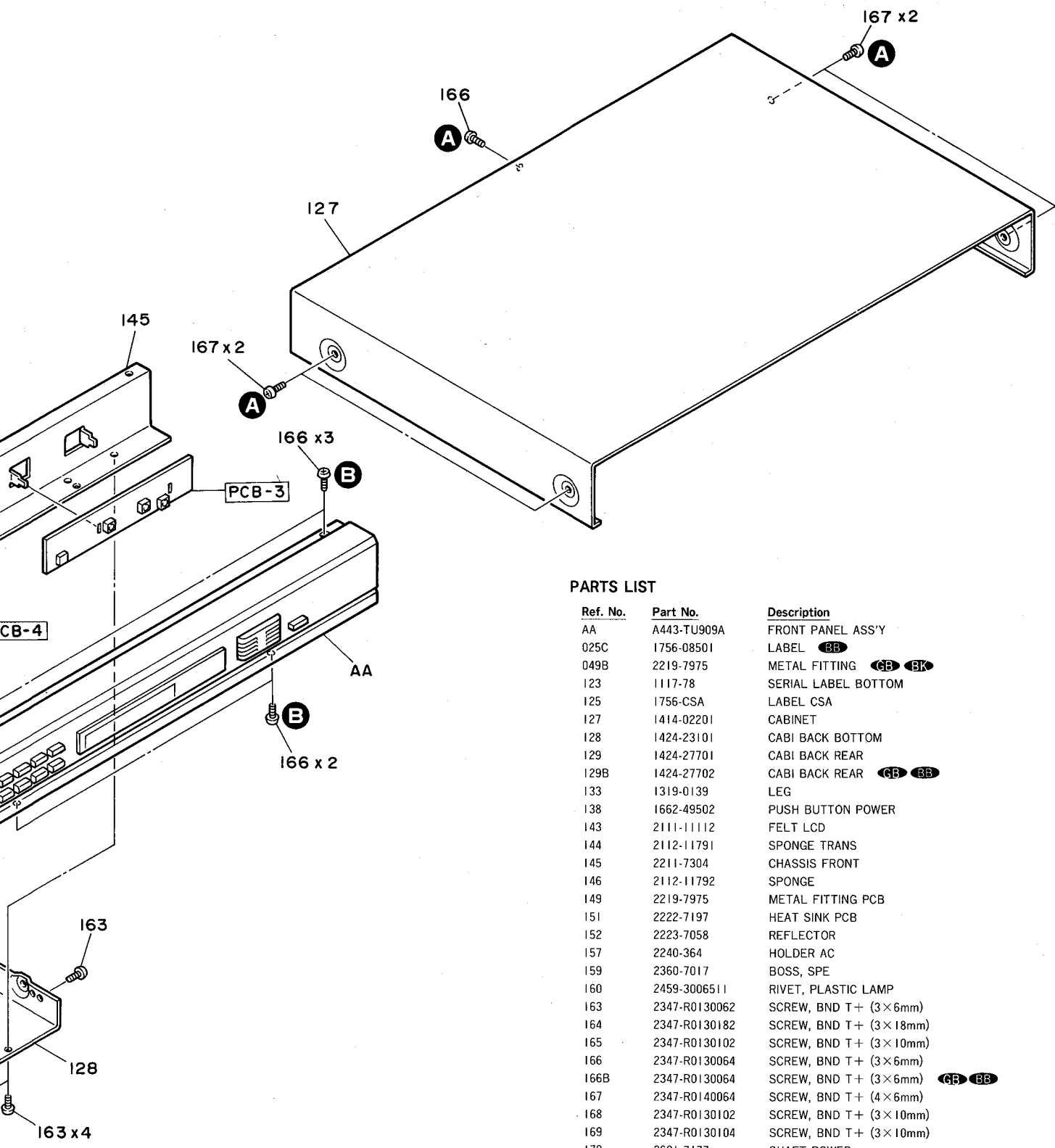
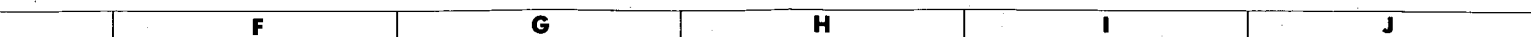

PARTS LIST

Ref. No.	Part No.	Description
AA	A443-TU909A	FRONT PANEL ASS'Y
025C	1756-08501	LABEL BB
049B	2219-7975	METAL FITTING GB BK
123	1117-78	SERIAL LABEL BOTTOM
125	1756-CSA	LABEL CSA
127	1414-02201	CABINET
128	1424-23101	CABI BACK BOTTOM
129	1424-27701	CABI BACK REAR
129B	1424-27702	CABI BACK REAR GB BB
133	1319-0139	LEG
138	1662-49502	PUSH BUTTON POWER
143	2111-11112	FELT LCD
144	2112-11791	SPONGE TRANS
145	2211-7304	CHASSIS FRONT
146	2112-11792	SPONGE
149	2219-7975	METAL FITTING PCB
151	2222-7197	HEAT SINK PCB
152	2223-7058	REFLECTOR
157	2240-364	HOLDER AC
159	2360-7017	BOSS, SPE
160	2459-3006511	RIVET, PLASTIC LAMP
163	2347-R0130062	SCREW, BND T+ (3×6mm)
164	2347-R0130182	SCREW, BND T+ (3×18mm)
165	2347-R0130102	SCREW, BND T+ (3×10mm)
166	2347-R0130064	SCREW, BND T+ (3×6mm)
166B	2347-R0130064	SCREW, BND T+ (3×6mm) GB BB
167	2347-R0140064	SCREW, BND T+ (4×6mm)
168	2347-R0130102	SCREW, BND T+ (3×10mm)
169	2347-R0130104	SCREW, BND T+ (3×10mm)
170	2601-7177	SHAFT POWER
173	2401-0317	WASHER, METAL TRANS
566	2240-7208	HOLDER
△719 (P1)	4161-71147	CORD W/PLUG
△719B (P1)	4161-7256	CORD W/PLUG AC GB
△719C (P1)	4161-04100	CORD W/PLUG AC BB
LI	5911-235	AM LOOP ANT
LUG1	4211-4	LUG GB BB
LUG2	4211-4	LUG BK

GENERAL UNIT
EXPLODED VIEW (FRONT PANEL ASS'Y)

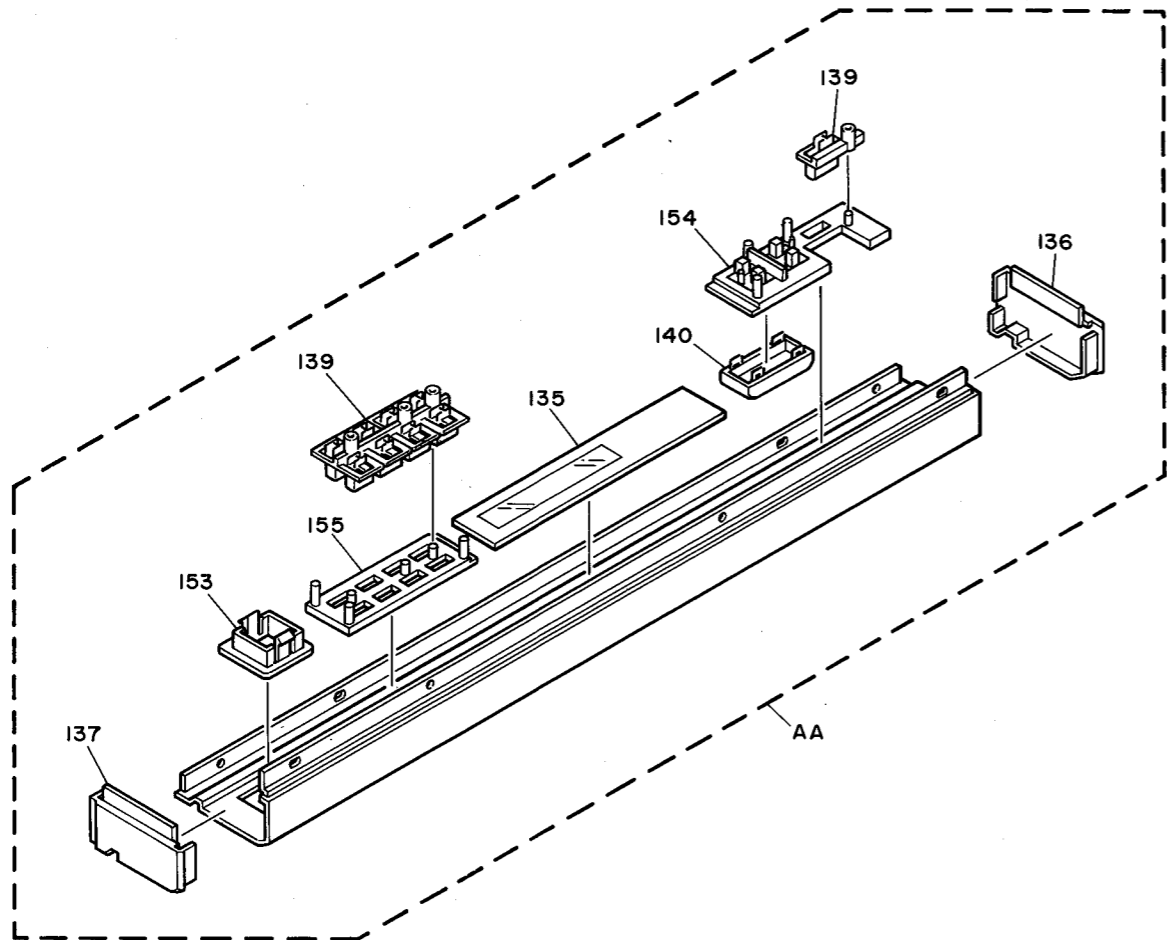

PARTS LIST

Ref. No.	Part No.	Description
AA	A443-TU909A	FRONT PANEL ASS'Y
135	I531-12002	WINDOW, FRONT
136	I562-06901	FRAME, R
137	I562-07001	FRAME, L
139	I662-37202	PUSH BUTTON, SEEK
140	I662-45002	PUSH BUTTON, UP/DOWN
153	2240-7209	HOLDER, POWER
154	2240-7332	HOLDER
155	2240-7333	HOLDER, PRESET

IC BLOCK DIAGRAM

IC201: LA1266 FM/AM IF

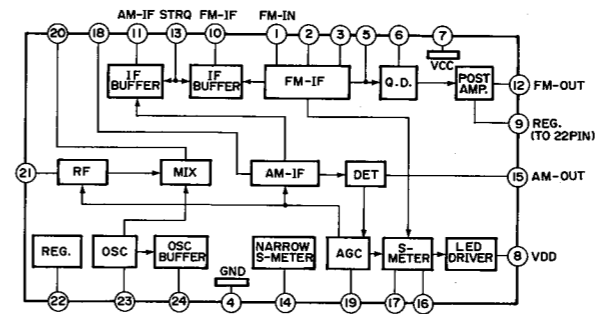

IC301: LA3410 PLL FM STEREO MPX

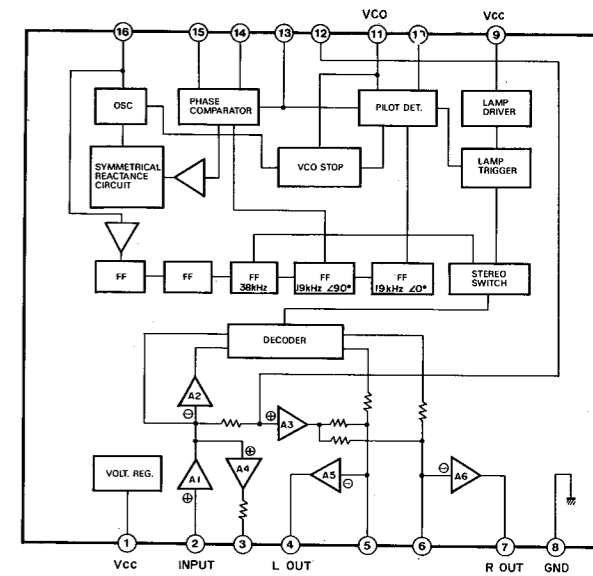

IC701: T9306F-025 MICRO PROCESSOR

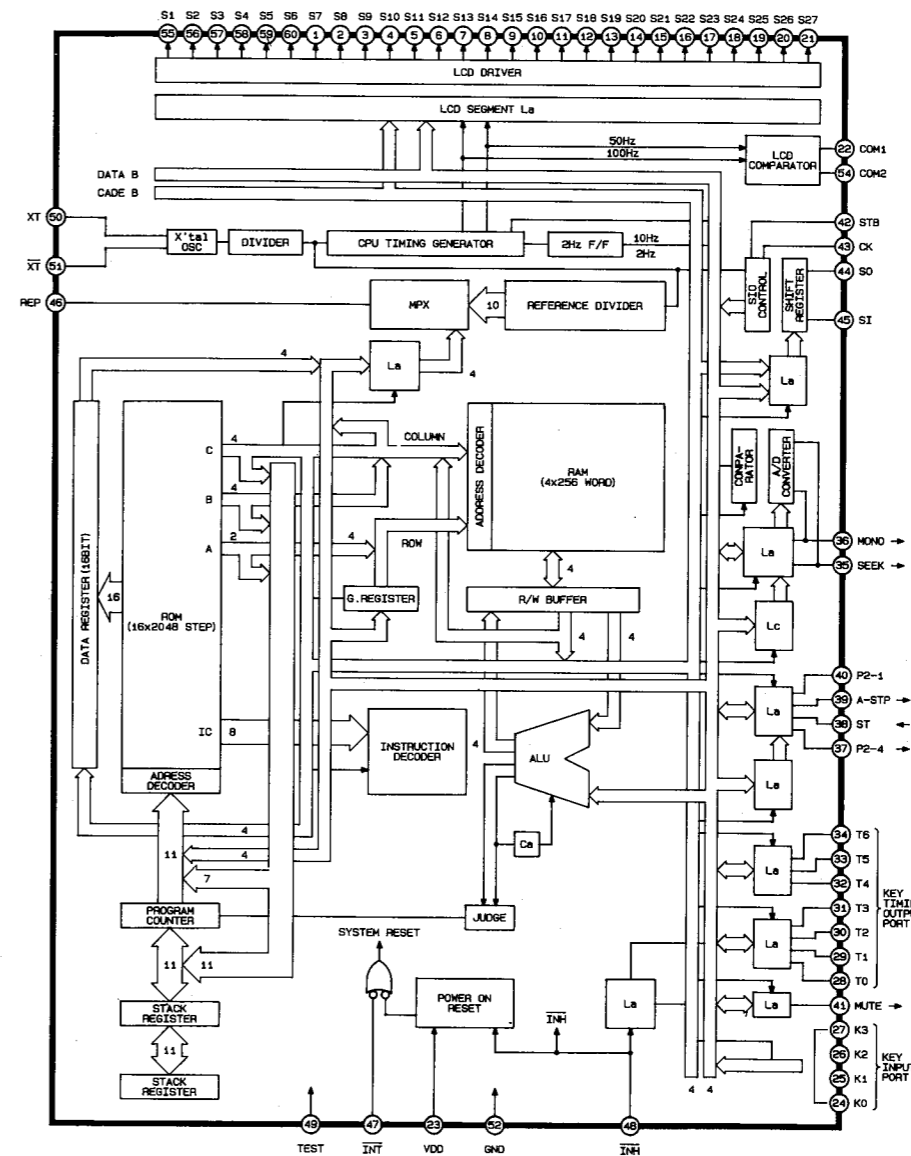

IC702: TC9172AP PLL LSI

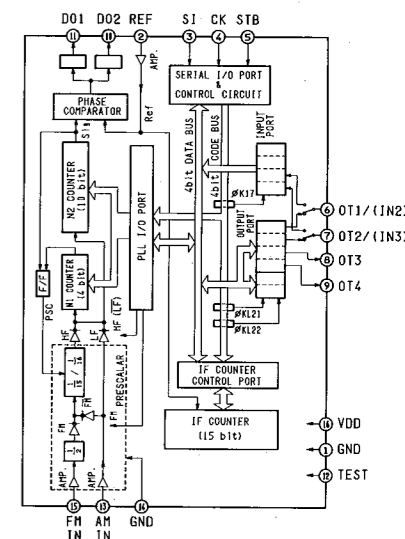

GENERAL UNIT
EXPLODED VIEW (FRONT PANEL ASS'Y)

1
2
3
4
5
6
7

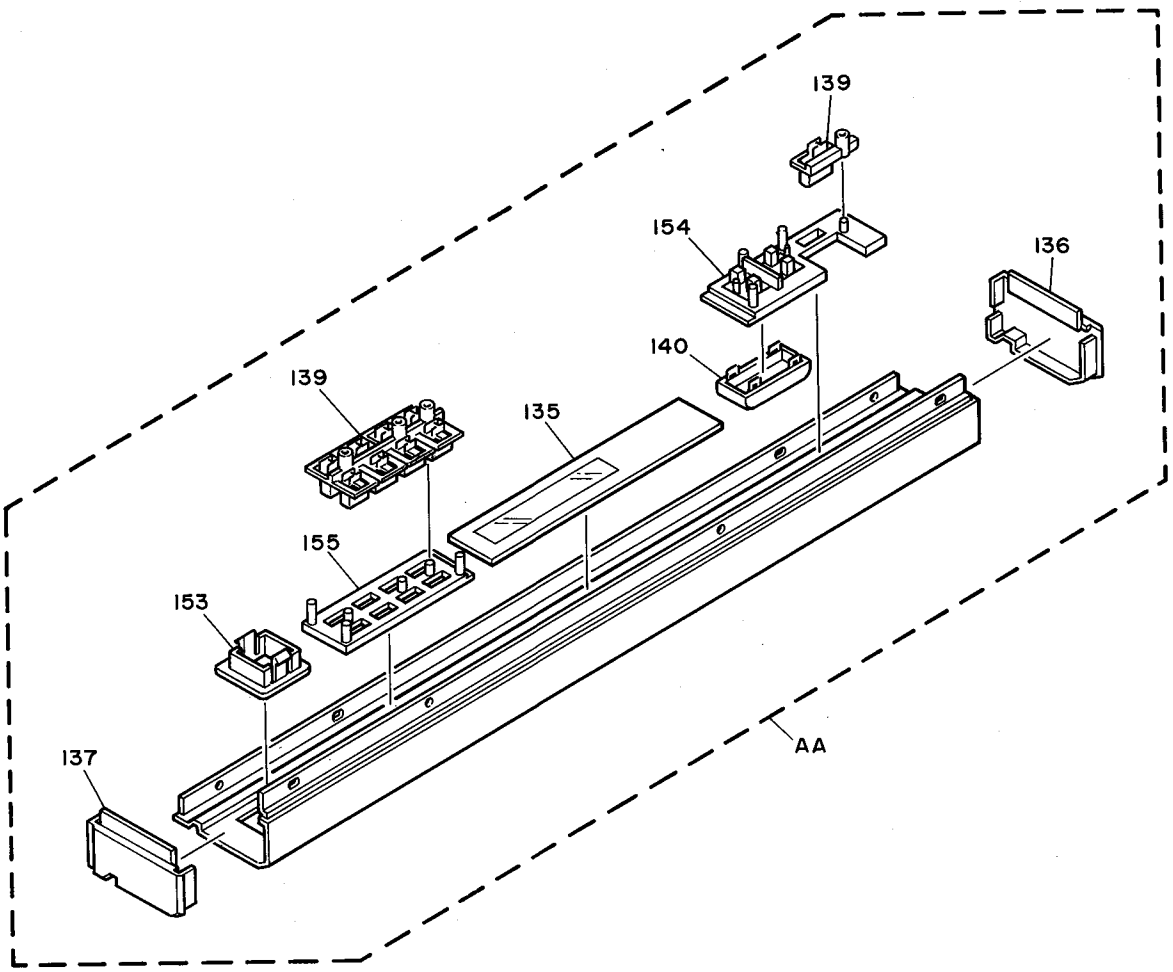

PARTS LIST

Ref. No.	Part No.	Description
AA	A443-TU909A	FRONT PANEL ASS'Y
135	1531-12002	WINDOW, FRONT
136	1562-06901	FRAME, R
137	1562-07001	FRAME, L
139	1662-37202	PUSH BUTTON, SEEK
140	1662-45002	PUSH BUTTON, UP/DOWN
153	2240-7209	HOLDER, POWER
154	2240-7332	HOLDER
155	2240-7333	HOLDER, PRESET

IC BLOCK DIAGRAM

IC201 : LA1266 FM/AM IF

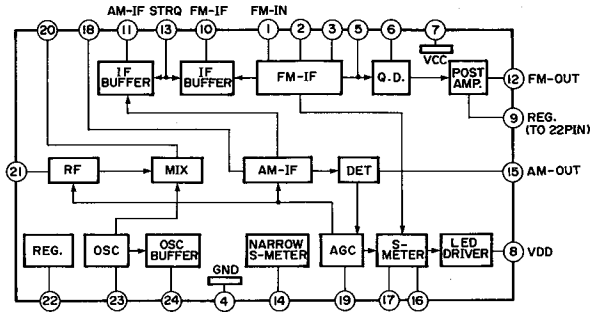

IC301 : LA3410 PLL FM STEREO MPX

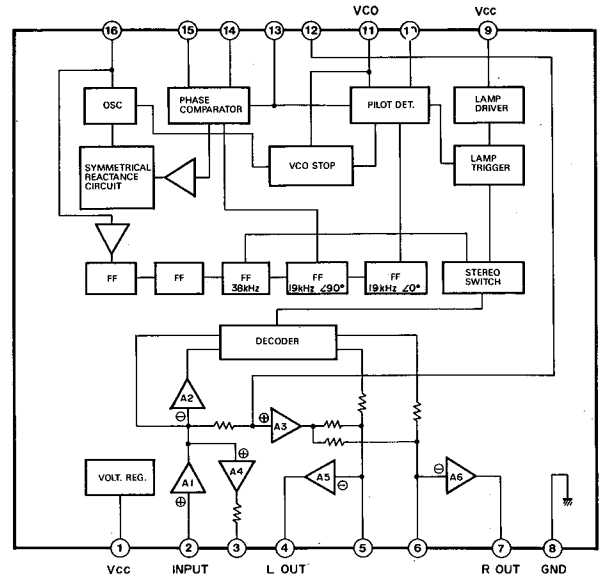

IC701 : T9306F-025 MICRO PROCESSOR

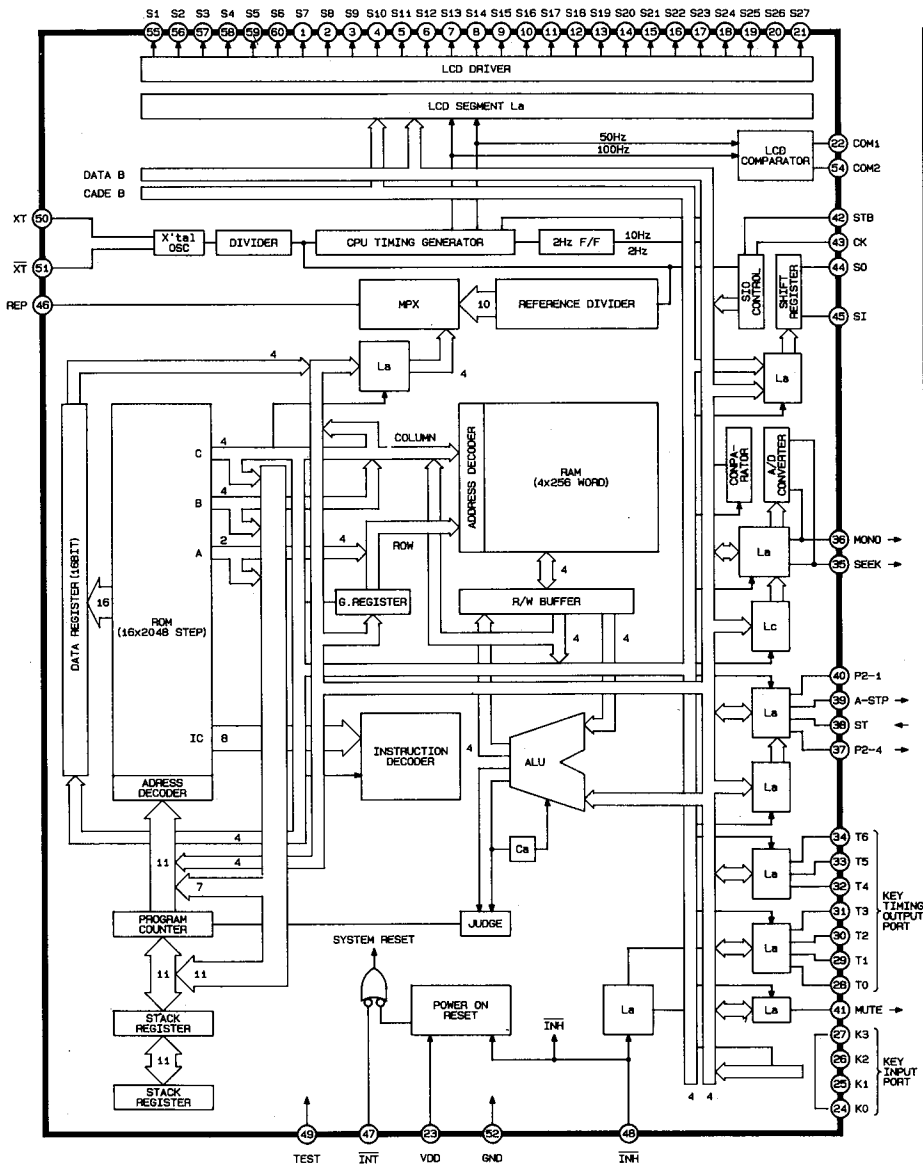

IC702 : TC9172AP PLL LSI

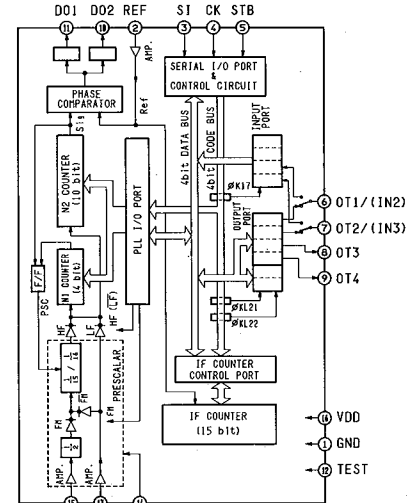

TERMINAL FUNCTION (IC701 and IC702)

IC number	Terminal number	Port name	Terminal code	I/O	Outline of functions	
					Segment name COM1	Segment name COM2
IC701	1	S7	S7	O	Received frequency display	Point 2 on level meter
	2	S8	S8	O	Received frequency display	Received frequency display
	3	S9	S9	O	Point 1 on level meter	Received frequency display
	4	S10	S10	O	Received frequency display	Received frequency display
	5	S11	S11	O	Received frequency display	Received frequency display
	6	S12	S12	O	Received frequency display	Received frequency display
	7	S13	S13	O	Received frequency display	Received frequency display
	8	S14	S14	O	Received frequency display	Received frequency display
	9	S15	S15	O	Received frequency display	Received frequency display
	10	S16	S16	O	Received frequency display	Received frequency display
	11	S17	S17	O	Received frequency display	Received frequency display
	12	S18	S18	O	Received frequency display	Received frequency display
	13	S19	S19	O	Received frequency display	Received frequency display
	14	S20	S20	O	Received frequency display	Received frequency display
	15	S21	S21	O	Received frequency display	Received frequency display
	16	S22	S22	O	Point 5 on level meter	Store mode (MEMORY)
	17	S23	S23	O		Received frequency display
	18	S24	S24	O	Received frequency display	Received frequency display
	19	S25	S25	O	MW band	FM stereo
	20	S26	S26	O	MW band	FM band
	21	S27	S27	O	LW band	SW band
	22	COM1	COM1	O	Common 1	
	23	V _{DD}	V _{DD}	I	Power supply	
	24	K0	K0	I	Key input	
	25	K1	K1	I	Key input	
	26	K2	K2	I	Key input	
	27	K3	K3	I	Key input	
	28	T0	T0	O	Key timing output	
	29	T1	T1	O	Key timing output	
	30	T2	T2	O	Key timing output	
	31	T3	T3	O	Key timing output	
	32	T4	T4	O	Key timing output	
	33	T5	T5	O	Key timing output	
	34	T6	T6	O	Key timing output	
	35	P3-2	AD IN	I	AD IN signal strength display input	
	36	P3-1	VREF	I	AD IN reference voltage input	
	37	P2-4	LOCAL IF	O	LOCAL DX select control output (FM, MW, LW)	
	38	P2-3	MONO	O	Forced output of mono control (FM mode only)	
	39	P2-2	AUTO-STOP	I	Stop signal input	
	40	P2-1	R-I	I	Remote control serial data input	
	41	MUTE	MUTE	O	Mute output	
	42	STB	STB	I	Strobe signal input	
	43	CK	CK	I	Serial clock signal input	

IC number	Terminal number	Port name	Terminal code	I/O	Outline of functions	
					Segment name COM1	Segment name COM2
IC701	44	SO	SO	O	Serial data output	
	45	SI	SI	I	Serial data input	
	46	REF	REF	I	Reference frequency input	
	47	$\overline{\text{INT}}$	$\overline{\text{INT}}$	I	Initialize input terminal	
	48	$\overline{\text{INH}}$	$\overline{\text{INH}}$	I	Normal mode (H level) Inhibit mode (L level)	
	49	TEST	TEST	I	Test terminal	
	50	XT	XT	O	Clock output	
	51	$\overline{\text{XT}}$	$\overline{\text{XT}}$	O	Clock output	
	52	GND	GND	—	GND pin	
	53	V _{DD}	V _{DD}	I	Power supply	
	54	COM2	COM2	O		Common 2
	55	S1	S1	O	Preset ch	Received frequency display
	56	S2	S2	O	Received frequency display	Received frequency display
	57	S3	S3	O	Received frequency display	Received frequency display
	58	S4	S4	O	Received frequency display	Received frequency display
	59	S5	S5	O	Point 4 on level meter	FW/SW unit
	60	S6	S6	O	Point 3 on level meter	MW/LW unit
IC702	1	GND	GND	I	GND terminal	
	2	REF	Reference frequency	I	Input signal (reference frequency) is supplied from controller side. Built-in amplifier, C coupling, small amplitude.	
	3	SI	Serial input	I/O	Serial I/O port	
	4	CK	Clock signal input		Set divide order and divide means, data for control IF counter and I/O port transmit and receive between controller and this terminal.	
	5	STB	Strobe signal input		SI, CK, STB = schmidt trigger input.	
	6	FM	Output port	O	General purpose output port, use high frequency selector and control signal output.	
	7	AM				
	8	LOCAL				
	9					
	10	Phase Comp. Output	Phase comparater output	O	Tri-state output of phase comparater, is parallel output.	
	11	TEST	Test terminal	I	Test mode control input, with built-in pull down resistor. Normally, this terminal use "open" "or" "GND".	
	12	AM _{IN}	AM local osc. input	I	Programable counter input, when AM band. Built-in amplifier, C coupling, small amplitude.	
	13	GND	Pre scaler section GND	I	Built-in pre scaler GND terminal.	
	14	FM _{IN}	FM local osc. input	I	Pre scaler input, when FM band. Built-in amplifier (f max = 120 MHz), C coupling, small amplitude.	
	15	V _{DD}	Power supply	I	Voltage supply (5V ± 10%)	

P. C. BOARDS (For North America area model)

PCB-1 Main P. C. Board

PCB-2 Power Supply P. C. Board

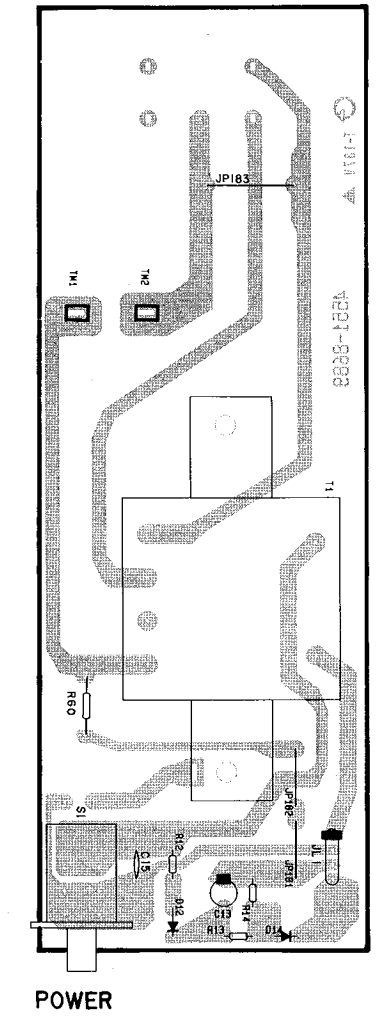
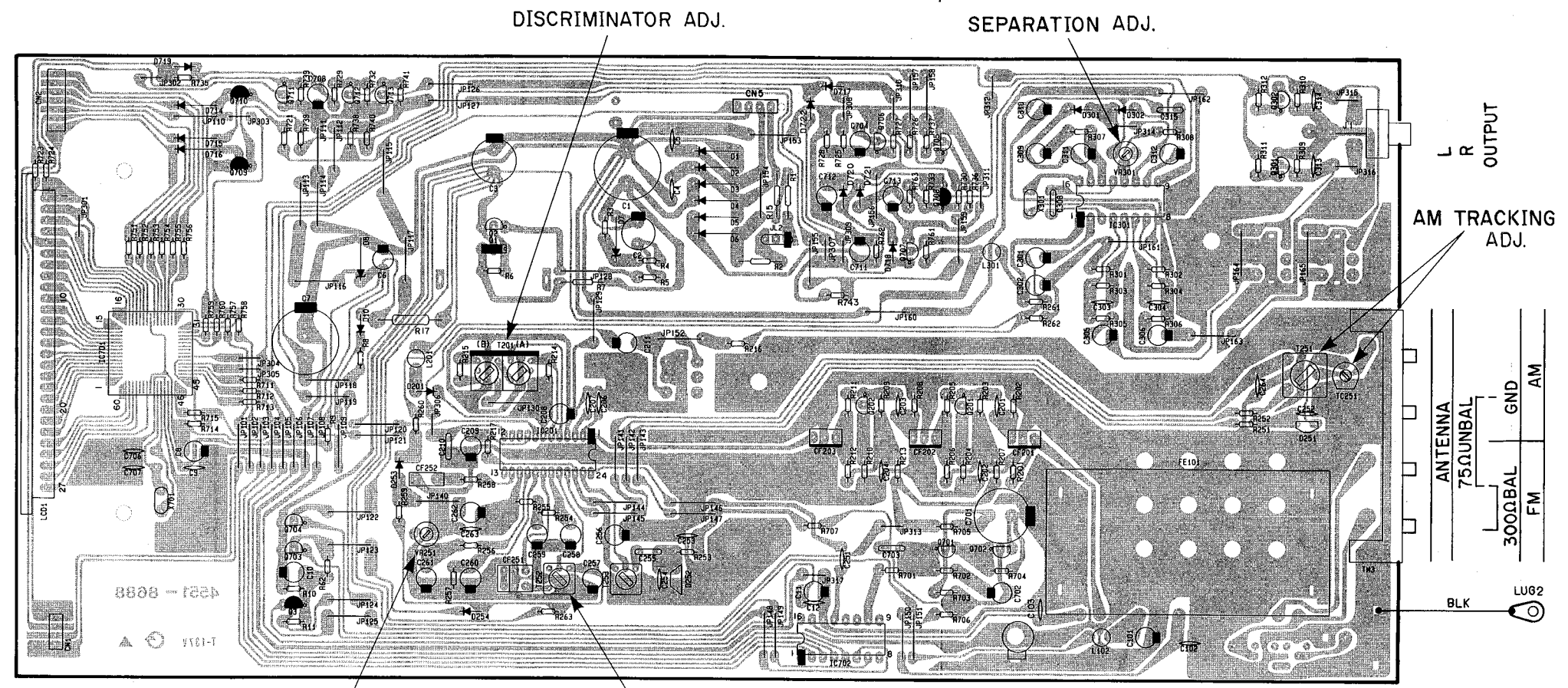

PCB-3 Up/Down P. C. Board

PCB-4 Preset P. C. Board

PCB-5 Lamp P. C. Board

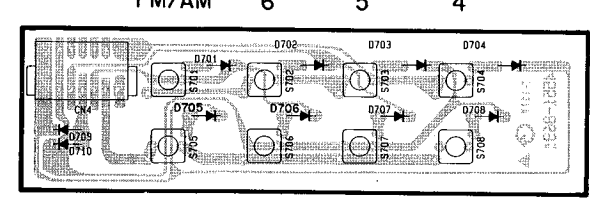
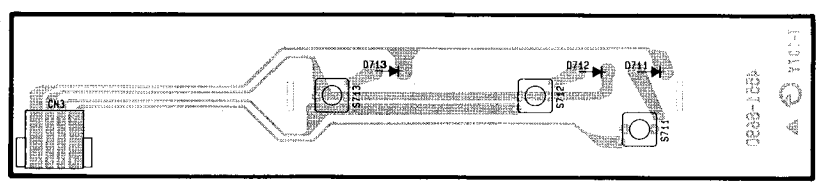

1
2
3
4
5
6
7

A B C D E

P. C. BOARDS (For North America area model)

PCB-1 Main P. C. Board

DISCRIMINATOR ADJ.

SEPAR

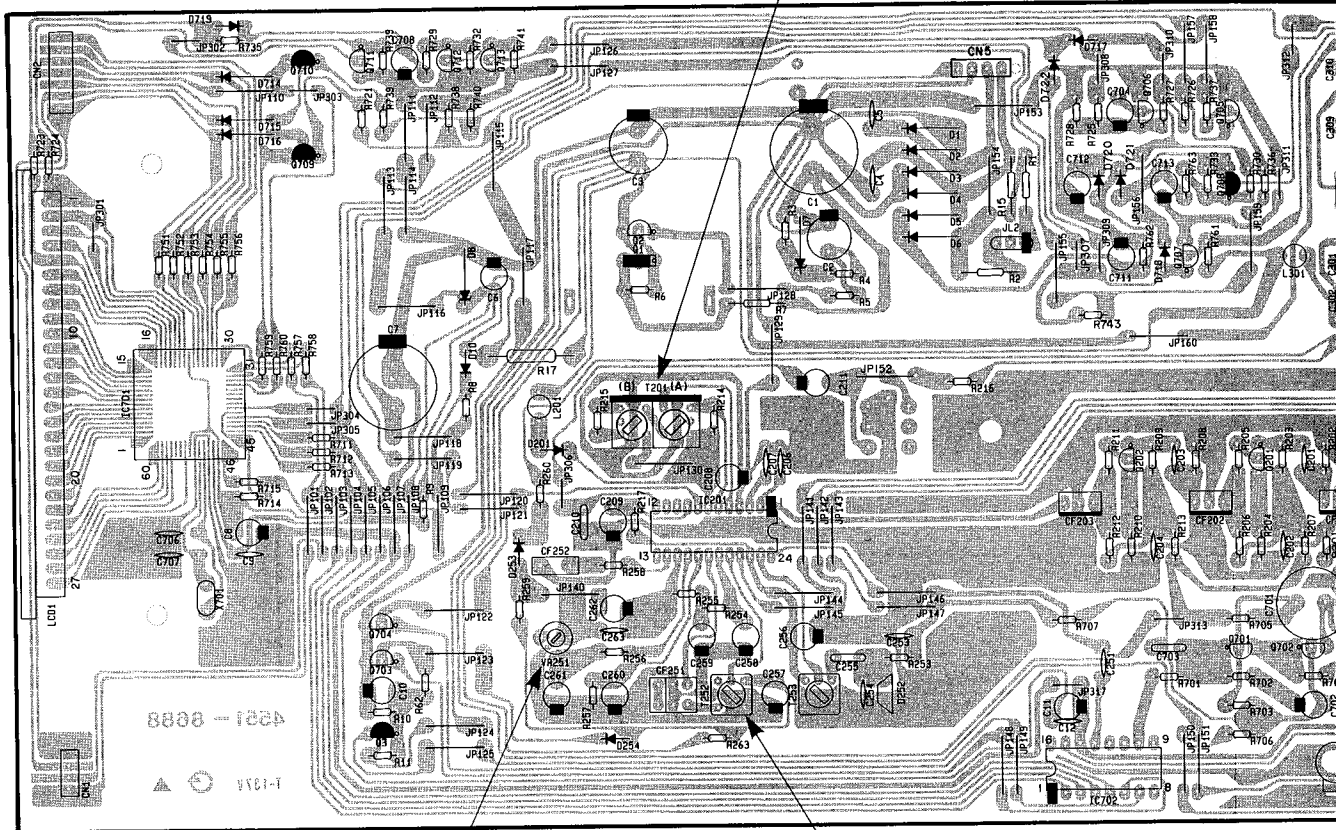

MUTING LEVEL ADJ.

AM IF ADJ

PCB-3 Up/Down P. C. Board

PCB-4 P

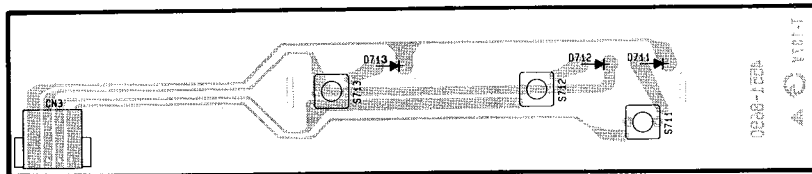

◁down TUNING up▷ seek

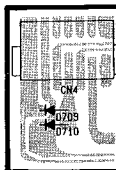

1
2
3
4
5
6
7

F

G

H

I

J

PCB-2 Power Supply P. C. Board

SEPARATION ADJ.

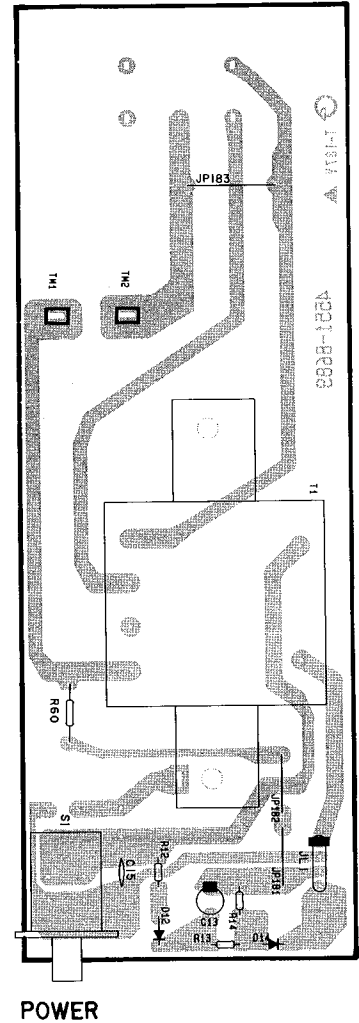
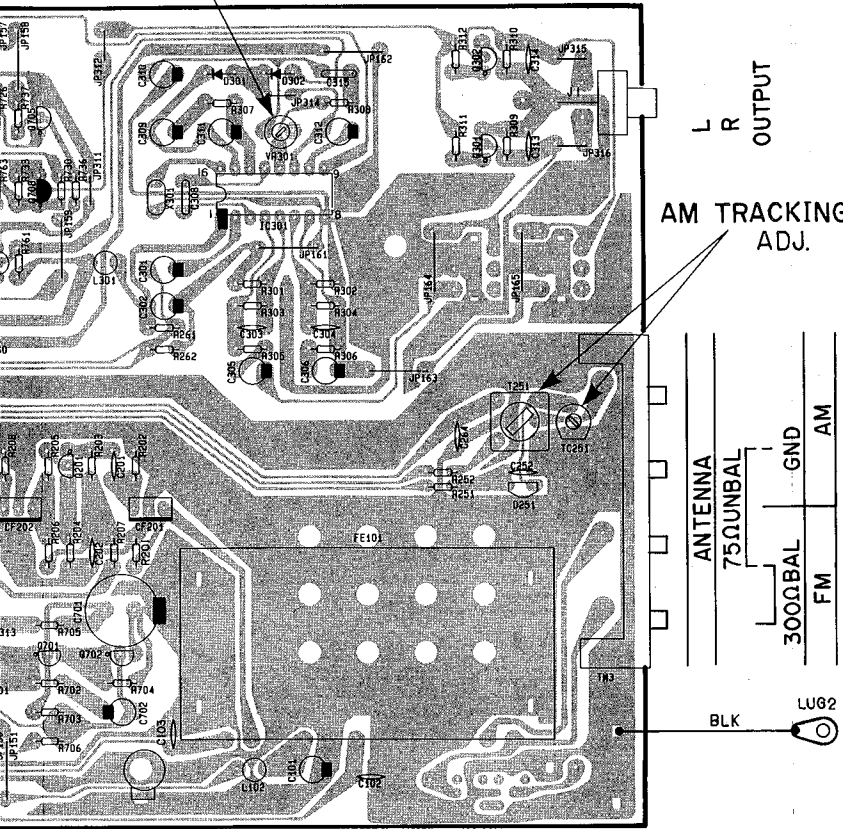

PCB-4 Preset P. C. Board

FM/AM 6 5 4

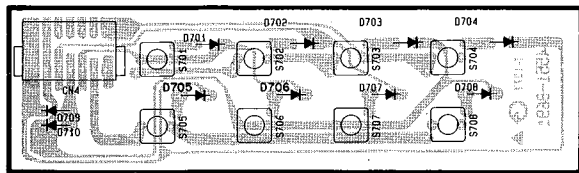

memory 3 2 1

PCB-5 Lamp P. C. Board



P. C. BOARDS (For General and Australia models)

PCB-1 Main P. C. Board

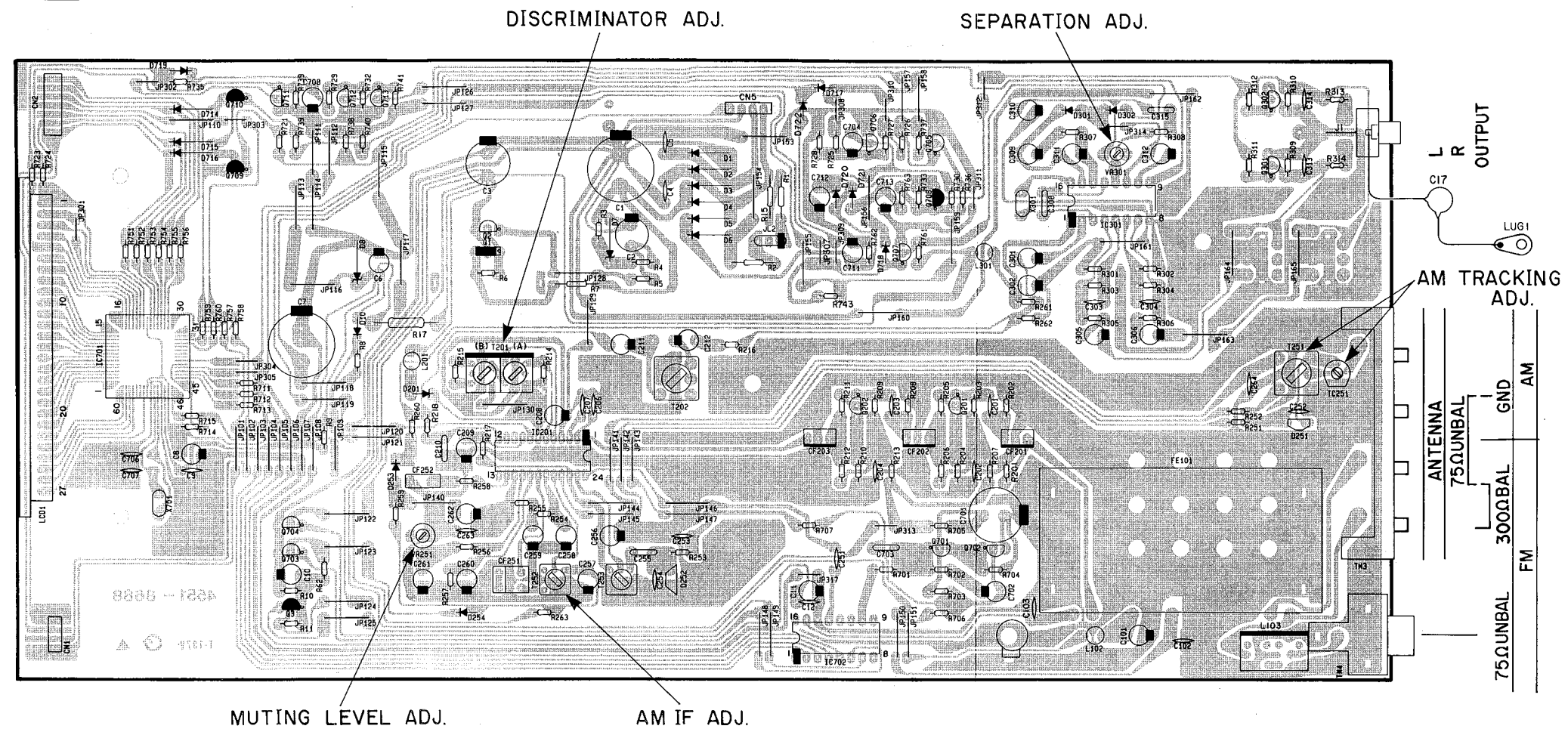

PCB-3 Tuning Switch P. C. Board

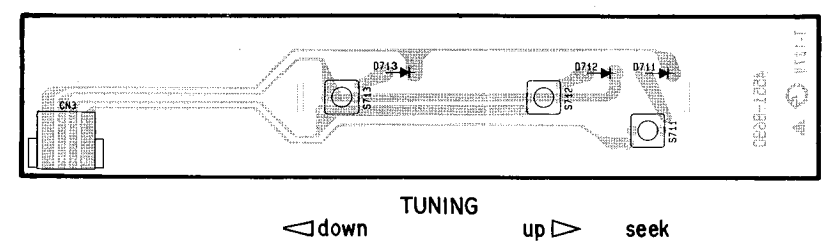

PCB-4 Preset P. C. Board

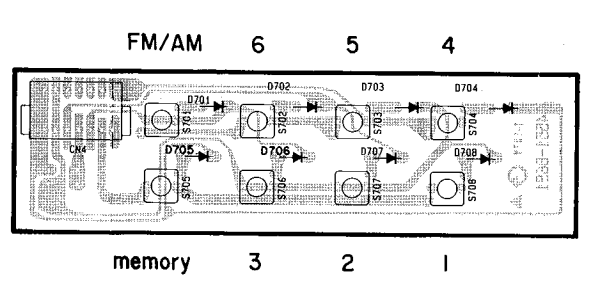

PCB-5 Lamp P. C. Board



P. C. BOARDS (For General and Australia models)

PCB-1 Main P. C. Board

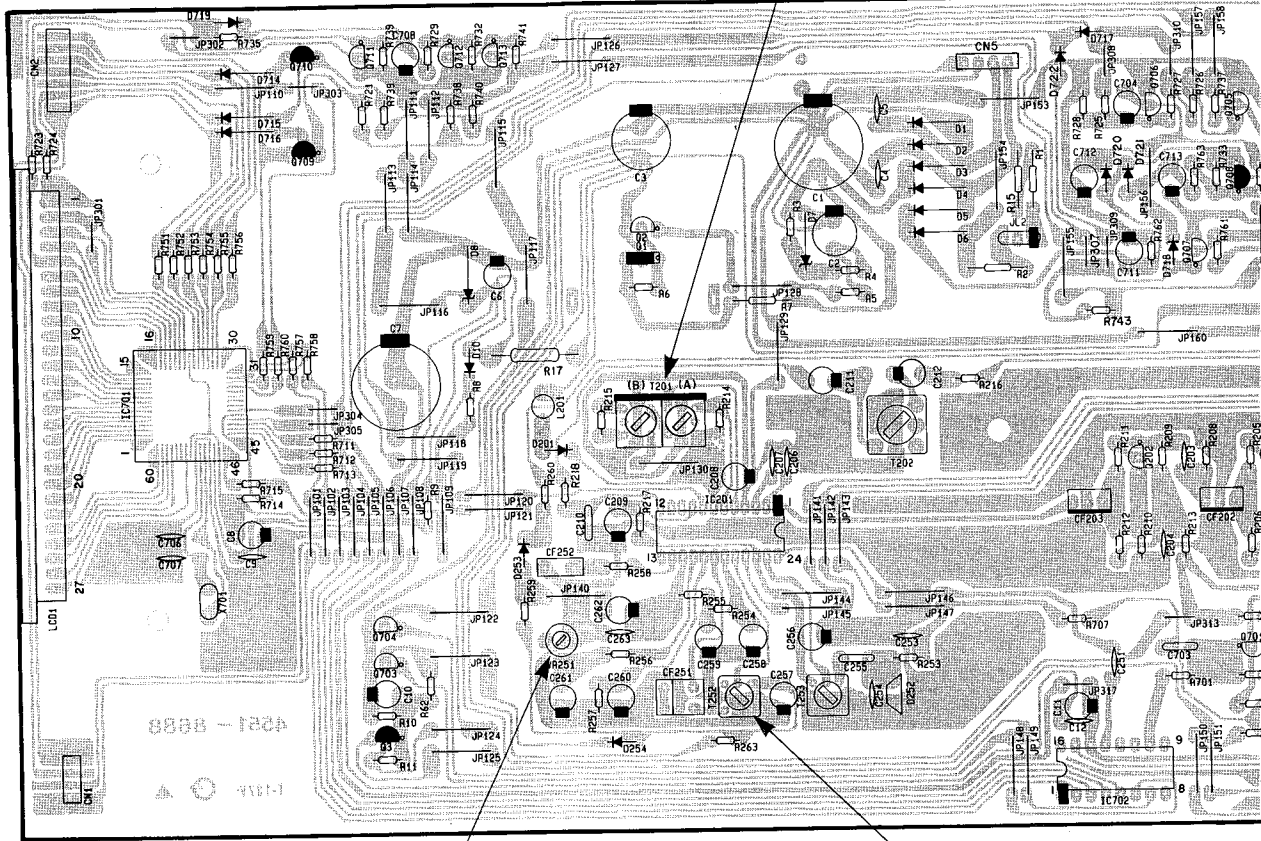

MUTING LEVEL ADJ.

DISCRIMINATOR ADJ.

AM IF ADJ.

PCB-3 Tuning Switch P. C. Board

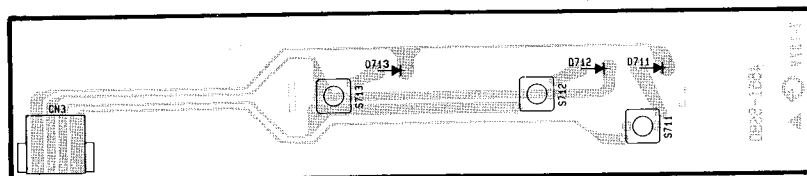

◁ down TUNING up ▷ seek

F

G

H

I

J

PCB-2 Power Supply P. C. Board

SEPARATION ADJ.

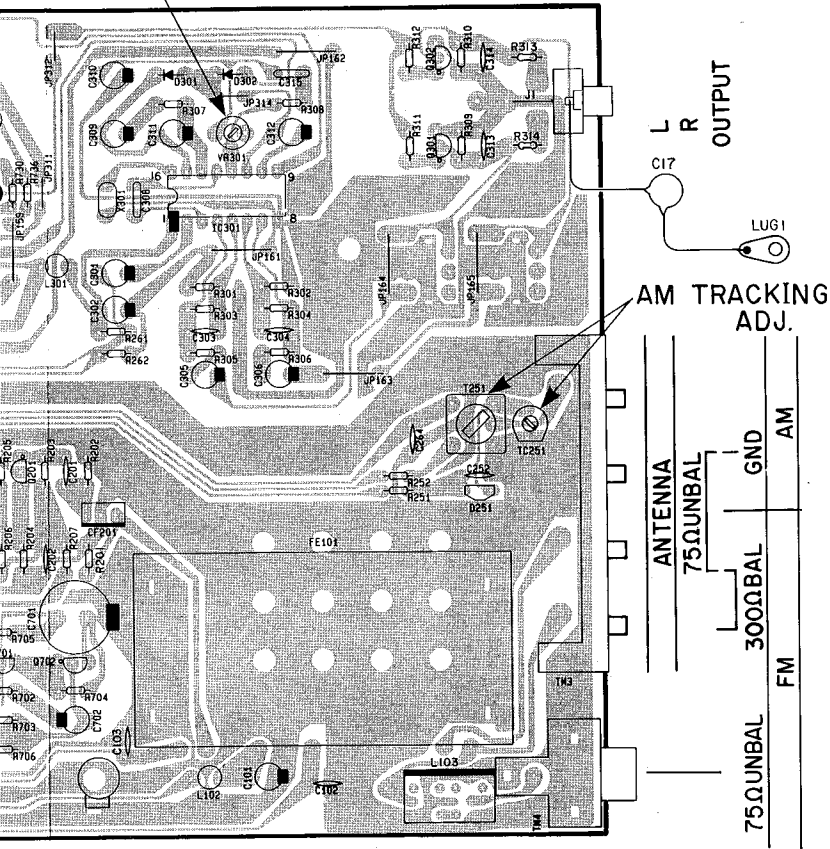

VOLTAGE SELECTOR

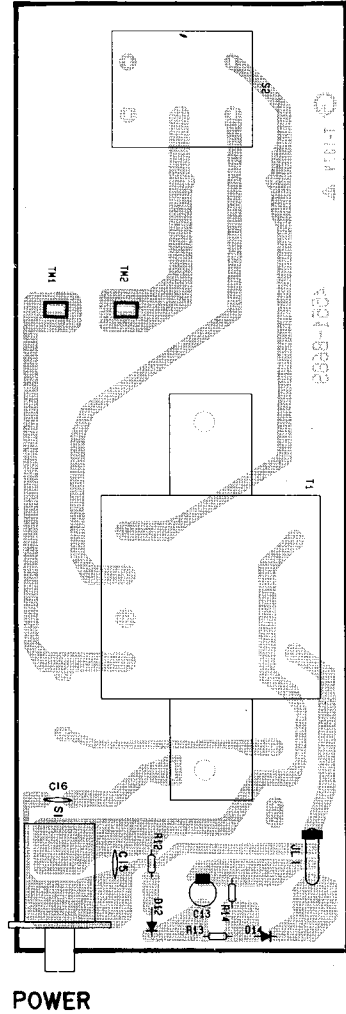

3-4 Preset P. C. Board

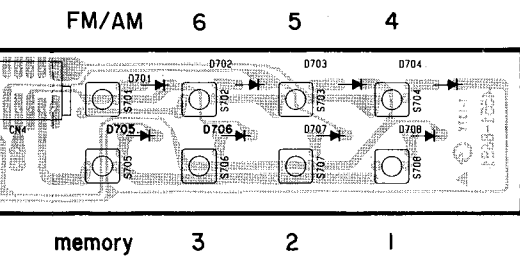

PCB-5 Lamp P. C. Board



WIRING DIAGRAM

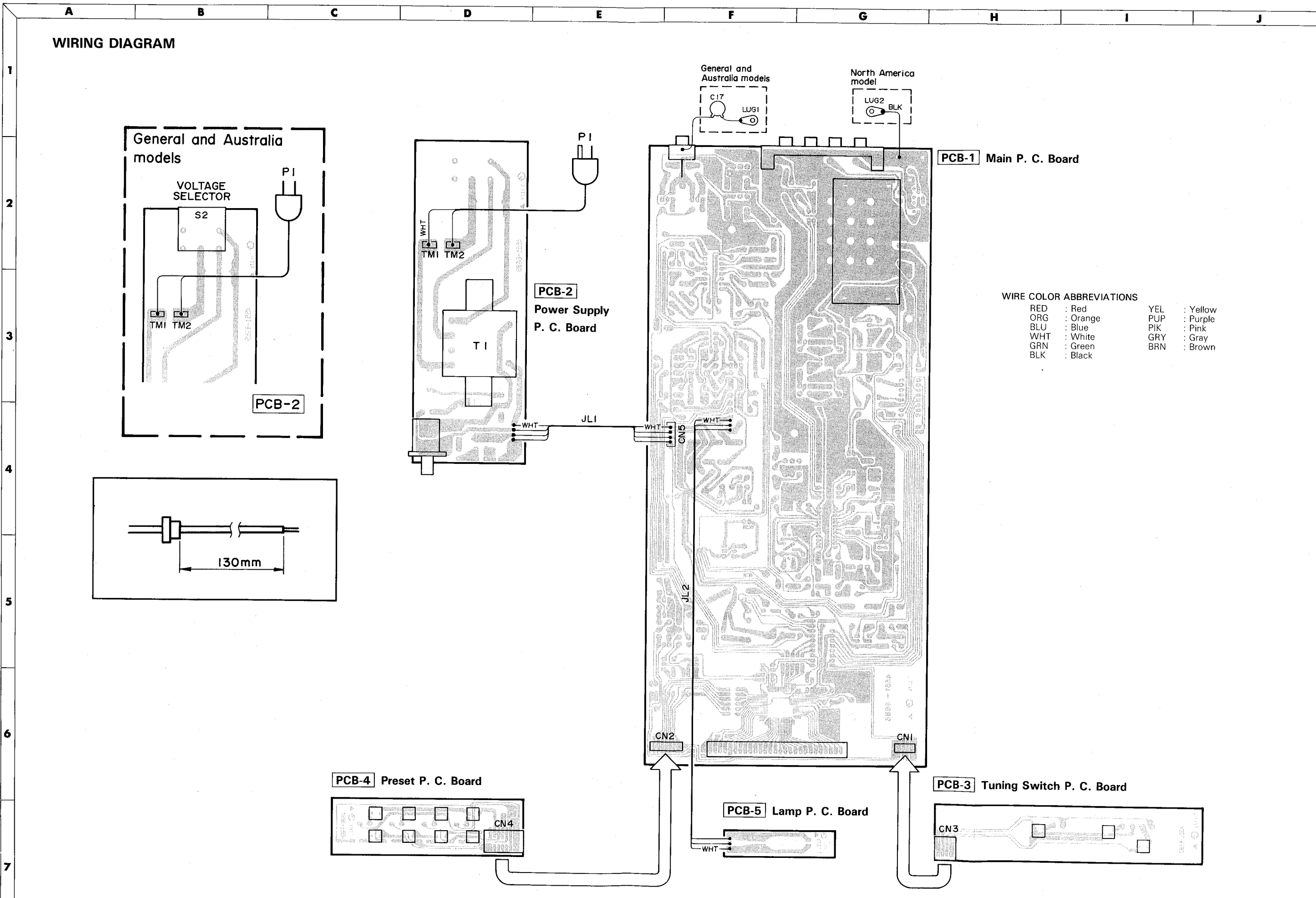

WIRING DIAGRAM

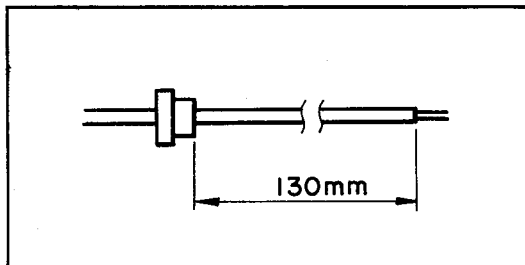
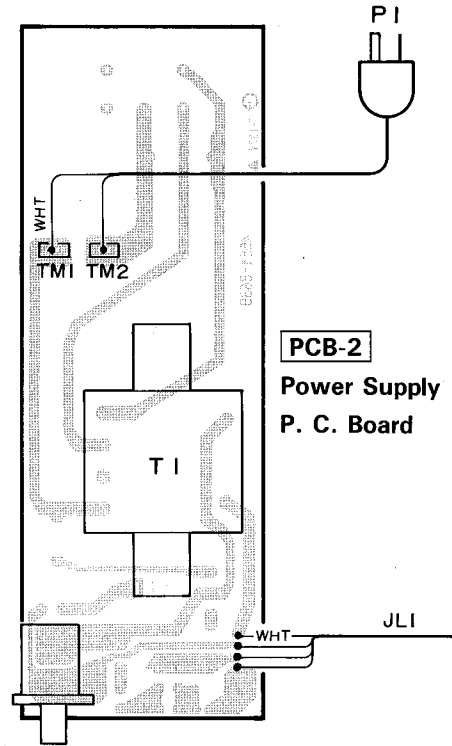
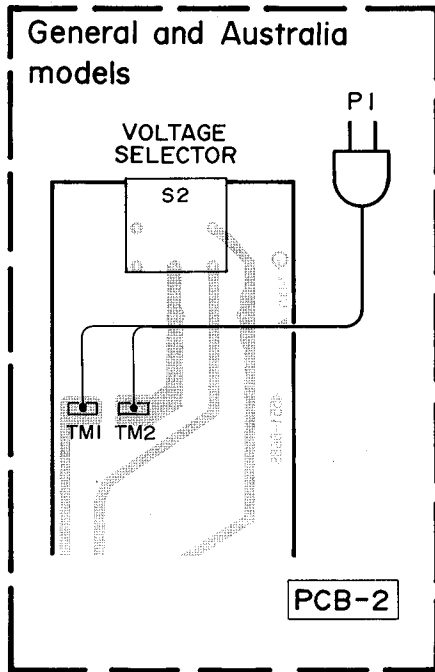

PCB-4 Preset P. C. Board

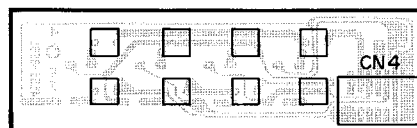

F

G

H

I

J

General and Australia models

North America model

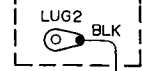
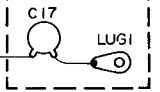

PCB-1 Main P. C. Board

WIRE COLOR ABBREVIATIONS

RED	: Red	YEL	: Yellow
ORG	: Orange	PUP	: Purple
BLU	: Blue	PIK	: Pink
WHT	: White	GRY	: Gray
GRN	: Green	BRN	: Brown
BLK	: Black		

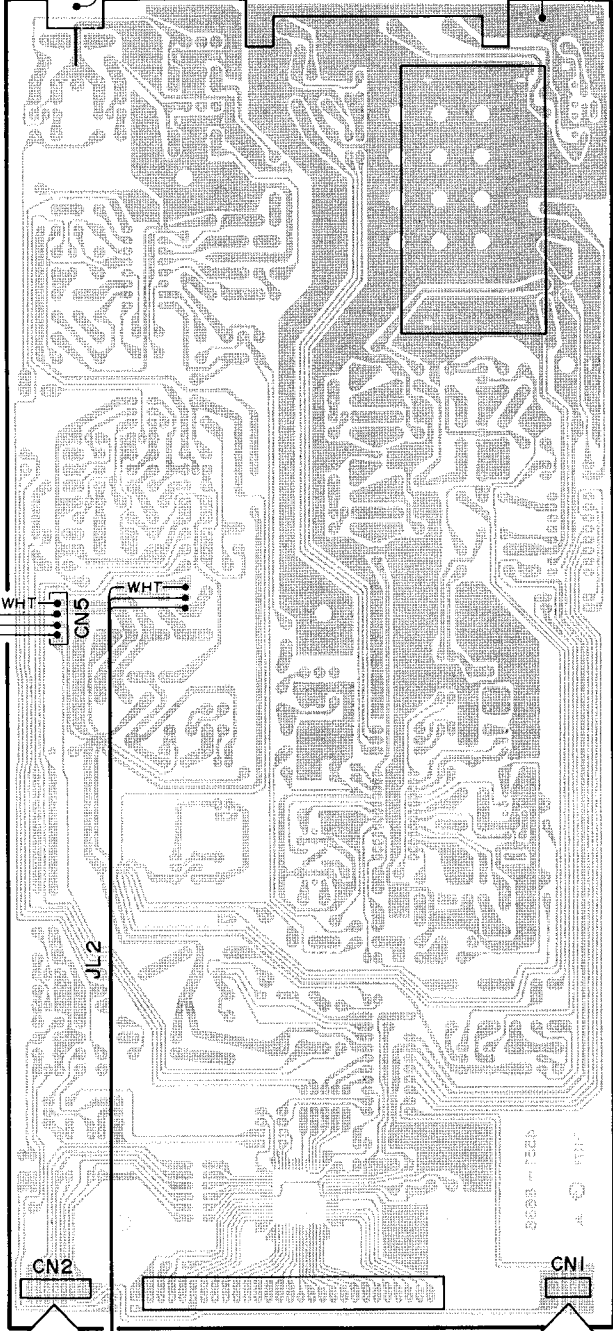

PCB-3 Tuning Switch P. C. Board

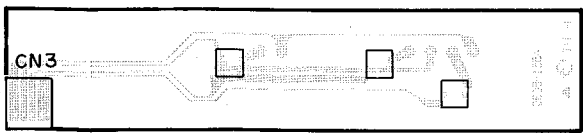

PCB-5 Lamp P. C. Board



ELECTRICAL PARTS LIST

Ser. No.	Ref. No.	Part No.	Description	Ser. No.	Ref. No.	Part No.	Description
PCB-1 MAIN P.C.BOARD							
CAPACITORS							
661	C1	5345-228D045	CAP, MINI ELE 2200 μ /25V	679	R1	5135-4R7522	RES, CBN 1/2P 4.7
662	C2	5345-476D041	CAP, MINI ELE 47 μ /25V	680	Δ R2	5102-6R85116	RES, FUSE 6.8
662	C3	5345-476D041	CAP, MINI ELE 47 μ /25V	671	R3	5232-272J16P	RES, CBN 1/6P 2.7K
667	C4	5361-473ZF	CAP, CER .047 μ	673	R4	5232-101J16P	RES, CBN 1/6P 100
667	C5	5361-473ZF	CAP, CER .047 μ	673	R5	5232-101J16P	RES, CBN 1/6P 100
658	C6	5345-107B041	CAP, MINI ELE 100 μ /10V	672	Δ R6	5232-331J16P	RES, CBN 1/6P 330
664	C7	5345-228A041	CAP, MINI ELE 2200 μ /6.3V	678	Δ R7	5102-2R25116	RES, FUSE 2.2
658	C8	5345-107B041	CAP, MINI ELE 100 μ /10V	677	R8	5232-821J16P	RES, CBN 1/6P 820
692	C9	5361-223Z921	CAP, CER .022 μ	648	R9	5232-104J16P	RES, CBN 1/6P 100K
506	C10	5345-226D041	CAP, MINI ELE 22 μ /25V	670	R10	5232-183J16P	RES, CBN 1/6P 18K
658	C11	5345-107B041	CAP, MINI ELE 100 μ /10V	671	R11	5232-272J16P	RES, CBN 1/6P 2.7K
665	C12	5361-102K918	CAP, CER 1000P	679	R15	5135-4R7522	RES, CBN 1/2P 4.7
051B	C17	5361-223ZF	CAP, CER .022 μ GB BB	668	R17	5171-221593	RES, MTL 1 220
505	C101	5345-476D041	CAP, MINI ELE 47 μ /25V	676	R62	5232-102J16P	RES, CBN 1/6P 1K
507	C102	5361-223Z921	CAP, CER .022 μ	548	R201	5232-331J16P	RES, CBN 1/6P 330
508	C103	5361-150KSL	CAP, CER 15P	549	R202	5232-391J16P	RES, CBN 1/6P 390
542	C201	5361-223Z921	CAP, CER .022 μ	551	R203	5232-154J16P	RES, CBN 1/6P 150K
542	C202	5361-223Z921	CAP, CER .022 μ	556	R204	5232-220J16P	RES, CBN 1/6P 22
542	C203	5361-223Z921	CAP, CER .022 μ	556B	R204	5232-180J16P	RES, CBN 1/6P 18 GB BB
542	C204	5361-223Z921	CAP, CER .022 μ	552	R205	5232-101J16P	RES, CBN 1/6P 100
542	C206	5361-223Z921	CAP, CER .022 μ	549	R206	5232-391J16P	RES, CBN 1/6P 390
542	C207	5361-223Z921	CAP, CER .022 μ	553	R207	5232-102J16P	RES, CBN 1/6P 1K
543	C208	5345-106F041	CAP, MINI ELE 10 μ /50V	549	R208	5232-391J16P	RES, CBN 1/6P 390
544	C209	5345-474F041	CAP, MINI ELE .47 μ /50V	551	R209	5232-154J16P	RES, CBN 1/6P 150K
546	C210	5361-101K918	CAP, CER 100P	556	R210	5232-220J16P	RES, CBN 1/6P 22
545	C211	5345-226D041	CAP, MINI ELE 22 μ /25V	556B	R210	5232-180J16P	RES, CBN 1/6P 18 GB BB
044B	C212	5345-226D041	CAP, MINI ELE 22 μ /25V GB BB	552	R211	5232-101J16P	RES, CBN 1/6P 100
576	C251	5361-103M920	CAP, CER .01 μ	549	R212	5232-391J16P	RES, CBN 1/6P 390
571	C252	5361-473ZF	CAP, CER .047 μ	553	R213	5232-102J16P	RES, CBN 1/6P 1K
571	C253	5361-473ZF	CAP, CER .047 μ	555	R214	5232-103J16P	RES, CBN 1/6P 10K
573	C254	5361-220JPH	CAP, CER 22P	559	R215	5232-332J16P	RES, CBN 1/6P 3.3K
572	C255	5359-4315851	CAP, PPP 430P	558	R216	5232-472J16P	RES, CBN 1/6P 4.7K
577	C256	5345-106F041	CAP, MINI ELE 10 μ /50V	558B	R216	5232-222J16P	RES, CBN 1/6P 2.2K GB BB
577	C257	5345-106F041	CAP, MINI ELE 10 μ /50V	558C	R216	5232-222J16P	RES, CBN 1/6P 2.2K
579	C258	5345-475F041	CAP, MINI ELE 4.7 μ /50V	557	R217	5232-123J16P	RES, CBN 1/6P 12K
579	C259	5345-475F041	CAP, MINI ELE 4.7 μ /50V	557B	R217	5232-333J16P	RES, CBN 1/6P 33K GB BB
578	C260	5345-105F041	CAP, MINI ELE 1 μ /50V	045B	R218	5232-222J16P	RES, CBN 1/6P 2.2K GB BB
581	C261	5345-474F041	CAP, MINI ELE .47 μ /50V	583	R251	5232-104J16P	RES, CBN 1/6P 100K
580	C262	5345-224F041	CAP, MINI ELE 22 μ /50V	587	R252	5232-471J16P	RES, CBN 1/6P 470
575	C263	5361-472M919	CAP, CER 4700P	583	R253	5232-104J16P	RES, CBN 1/6P 100K
571	C264	5361-473ZF	CAP, CER .047 μ	586	R254	5232-103J16P	RES, CBN 1/6P 10K
599	C301	5345-226D041	CAP, MINI ELE 22 μ /25V	586	R255	5232-103J16P	RES, CBN 1/6P 10K
600	C302	5345-476D041	CAP, MINI ELE 47 μ /25V	584	R256	5232-822J16P	RES, CBN 1/6P 8.2K
605	C303	5361-471K918	CAP, CER 470P	590	R257	5232-223J16P	RES, CBN 1/6P 22K
605B	C303	5361-221K918	CAP, CER 220P GB BB	588	R258	5232-820J16P	RES, CBN 1/6P 82
605	C304	5361-471K918	CAP, CER 470P	589	R259	5232-473J16P	RES, CBN 1/6P 47K
605B	C304	5361-221K918	CAP, CER 220P GB BB	582	R260	5232-123J16P	RES, CBN 1/6P 12K
604	C305	5345-225F041	CAP, MINI ELE 2.2 μ /50V	582B	R260	5232-153J16P	RES, CBN 1/6P 15K GB BB
604	C306	5345-225F041	CAP, MINI ELE 2.2 μ /50V	583	R261	5232-104J16P	RES, CBN 1/6P 100K
608	C308	5354-473K1HM	CAP, MYL .047 μ	583	R262	5232-104J16P	RES, CBN 1/6P 100K
601	C309	5345-474F0951	CAP, MINI ELE .47 μ /50V	585	R263	5232-272J16P	RES, CBN 1/6P 2.7K
603	C310	5345-106F041	CAP, MINI ELE 10 μ /50V	613	R301	5232-124J16P	RES, CBN 1/6P 120K
602	C311	5345-224F0951	CAP, MINI ELE 22 μ /50V	613B	R301	5232-154J16P	RES, CBN 1/6P 150K GB BB
604	C312	5345-225F041	CAP, MINI ELE 2.2 μ /50V	613	R302	5232-124J16P	RES, CBN 1/6P 120K
610	C313	5361-472M919	CAP, CER 4700P	613B	R302	5232-154J16P	RES, CBN 1/6P 150K GB BB
610	C314	5361-472M919	CAP, CER 4700P	611	R303	5232-154J16P	RES, CBN 1/6P 150K
609	C315	5361-101K918	CAP, CER 100P	611B	R303	5232-184J16P	RES, CBN 1/6P 180K GB BB
635	C701	5345-227C041	CAP, MINI ELE 220 μ /16V	611	R304	5232-154J16P	RES, CBN 1/6P 150K
633	C702	5345-684F0951	CAP, MINI ELE .68 μ /50V	611B	R304	5232-184J16P	RES, CBN 1/6P 180K GB BB
634	C703	5354-473K1HM	CAP, MYL .047 μ	612	R305	5232-332J16P	RES, CBN 1/6P 3.3K
631	C704	5345-105F041	CAP, MINI ELE 1 μ /50V	612	R306	5232-332J16P	RES, CBN 1/6P 3.3K
649	C706	5361-360J930	CAP, CER 36P	615	R307	5232-472J16P	RES, CBN 1/6P 4.7K
649	C707	5361-360J930	CAP, CER 36P	614	R308	5232-103J16P	RES, CBN 1/6P 10K
632	C708	5345-225F041	CAP, MINI ELE 2.2 μ /50V	614	R309	5232-103J16P	RES, CBN 1/6P 10K
641	C711	5345-106F041	CAP, MINI ELE 10 μ /50V	614	R310	5232-103J16P	RES, CBN 1/6P 10K
650	C712	5345-107D041	CAP, MINI ELE 100 μ /25V	614	R311	5232-103J16P	RES, CBN 1/6P 10K
620	C713	5345-475F041	CAP, MINI ELE 4.7 μ /50V	614	R312	5232-103J16P	RES, CBN 1/6P 10K
				046B	R313	5232-102J16P	RES, CBN 1/6P 1K GB BB
				046B	R314	5232-102J16P	RES, CBN 1/6P 1K GB BB
				637	R701	5232-103J16P	RES, CBN 1/6P 10K
				647	R702	5232-222J16P	RES, CBN 1/6P 2.2K

Ser. No.	Ref. No.	Part No.	Description
637	R703	5232-103J16P	RES, CBN 1/6P 10K
639	R704	5232-473J16P	RES, CBN 1/6P 47K
642	R705	5232-102J16P	RES, CBN 1/6P 1K
642	R706	5232-102J16P	RES, CBN 1/6P 1K
642	R707	5232-102J16P	RES, CBN 1/6P 1K
637	R711	5232-103J16P	RES, CBN 1/6P 10K
637	R712	5232-103J16P	RES, CBN 1/6P 10K
637	R713	5232-103J16P	RES, CBN 1/6P 10K
645	R714	5232-105J16P	RES, CBN 1/6P 1M
637	R715	5232-103J16P	RES, CBN 1/6P 10K
646	R717	5232-335J16P	RES, CBN 1/6P 3.3M
640	R721	5232-223J16P	RES, CBN 1/6P 22K
619	R723	5232-334J16P	RES, CBN 1/6P 330K
645	R724	5232-105J16P	RES, CBN 1/6P 1M
637	R725	5232-103J16P	RES, CBN 1/6P 10K
640	R726	5232-223J16P	RES, CBN 1/6P 22K
640	R727	5232-223J16P	RES, CBN 1/6P 22K
640	R728	5232-223J16P	RES, CBN 1/6P 22K
619	R729	5232-334J16P	RES, CBN 1/6P 330K
640	R730	5232-223J16P	RES, CBN 1/6P 22K
645	R732	5232-105J16P	RES, CBN 1/6P 1M
616	R733	5232-822J16P	RES, CBN 1/6P 8.2K
645	R735	5232-105J16P	RES, CBN 1/6P 1M
640	R736	5232-223J16P	RES, CBN 1/6P 22K
638	R737	5232-100J16P	RES, CBN 1/6P 10
642	R738	5232-102J16P	RES, CBN 1/6P 1K
640	R739	5232-223J16P	RES, CBN 1/6P 22K
640	R740	5232-223J16P	RES, CBN 1/6P 22K
640	R741	5232-223J16P	RES, CBN 1/6P 22K
618	R742	5232-474J16P	RES, CBN 1/6P 470K
640	R743	5232-223J16P	RES, CBN 1/6P 22K
637	R751	5232-103J16P	RES, CBN 1/6P 10K
637	R752	5232-103J16P	RES, CBN 1/6P 10K
637	R753	5232-103J16P	RES, CBN 1/6P 10K
637	R754	5232-103J16P	RES, CBN 1/6P 10K
637	R755	5232-103J16P	RES, CBN 1/6P 10K
637	R756	5232-103J16P	RES, CBN 1/6P 10K
637	R757	5232-103J16P	RES, CBN 1/6P 10K
637	R758	5232-103J16P	RES, CBN 1/6P 10K
617	R759	5232-332J16P	RES, CBN 1/6P 3.3K
637	R760	5232-103J16P	RES, CBN 1/6P 10K
644	R761	5232-332J16P	RES, CBN 1/6P 3.3K
643	R762	5232-682J16P	RES, CBN 1/6P 6.8K
639	R763	5232-473J16P	RES, CBN 1/6P 47K
INTEGRATED CIRCUITS			
531	IC201	5653-LA1266	IC, LINEAR
591	IC301	5653-LA3410	IC, LINEAR
621	IC701	5654-T9306F25	IC, DIGITAL
627	IC702	5654-TC9172AP	IC, DIGITAL
TRANSISTORS			
651	Q1	5612-1375	XISTOR, PNP A
652	Q2	5613-2603(E)or(F)	XISTOR, NPN R
653	Q3	5611-1115(E)or(F)	XISTOR, PNP R
532	Q201	5613-2058(N)or(P)	XISTOR, NPN R
532	Q202	5613-2058(N)or(P)	XISTOR, NPN R
592	Q301	5613-2878(B)	XISTOR, NPN R
592	Q302	5613-2878(B)	XISTOR, NPN R
624	Q701	5613-2240(BL)	XISTOR, NPN R
625	Q702	5613-2603(E)or(F)	XISTOR, NPN R
623	Q703	5613-RN1203	XISTOR, NPN R
623	Q704	5613-RN1203	XISTOR, NPN R
623	Q705	5613-RN1203	XISTOR, NPN R
625	Q706	5613-2603(E)or(F)	XISTOR, NPN R
623	Q707	5613-RN1203	XISTOR, NPN R
622	Q708	5611-1115(E)or(F)	XISTOR, PNP R
622	Q709	5611-1115(E)or(F)	XISTOR, PNP R
622	Q710	5611-1115(E)or(F)	XISTOR, PNP R
625	Q711	5613-2603(E)or(F)	XISTOR, NPN R
625	Q712	5613-2603(E)or(F)	XISTOR, NPN R
623	Q713	5613-RN1203	XISTOR, NPN R
DIODES			
654	ΔD1	5632-S5566B	DIODE, RECT

Ser. No.	Ref. No.	Part No.	Description
654	ΔD2	5632-S5566B	DIODE, RECT
654	ΔD3	5632-S5566B	DIODE, RECT
654	ΔD4	5632-S5566B	DIODE, RECT
654	ΔD5	5632-S5566B	DIODE, RECT
654	ΔD6	5632-S5566B	DIODE, RECT
656	D7	5635-HZ12C2L	DIODE, ZENER
657	D8	5635-HZ6B1L	DIODE, ZENER
655	D10	5631-ISS133	DIODE, DET
538	D201	5631-ISS133	DIODE, DET
561	D251	5633-ISV149	DIODE, CAP
561	D252	5633-ISV149	DIODE, CAP
562	D253	5631-ISS133	DIODE, DET
562	D254	5631-ISS133	DIODE, DET
593	D301	5631-ISS133	DIODE, DET
593	D302	5631-ISS133	DIODE, DET
636	D714	5631-IS2473	DIODE, DET
636	D715	5631-IS2473	DIODE, DET
636	D716	5631-IS2473	DIODE, DET
628	D717	5631-ISS133	DIODE, DET
628	D718	5631-ISS133	DIODE, DET
628	D719	5631-ISS133	DIODE, DET
628	D720	5631-ISS133	DIODE, DET
628	D721	5631-ISS133	DIODE, DET
628	D722	5631-ISS133	DIODE, DET
MISCELLANEOUS			
717	J1	4482-0133	PIN JACK, 2P
503	L102	5995-2R2J107	COIL W/CORE
050B	L103	5214-78	LC COMPOSITE GB BB
537	L201	5995-2R2J107	COIL W/CORE
596	L301	5995-2R2J107	COIL W/CORE
536	T201	5572-10201	DISCRI 7
043B	T202	5214-13101	LC COMPOSITE GB BB
570	T251	5933-S0102	COIL CASE, 10
565	T252	5552-70114	IFT, AM 7
564	T253	5922-00112	OSC COIL, 7
594	X301	5693-CSB456F1	OSC, CER
626	X701	5691-00720027	XTAL, OSC
535	CF201	5671-7147A	FILTER, CER S
535B	CF201	5671-7142A	FILTER, CER S GB BB
535	CF202	5671-7147A	FILTER, CER S
535B	CF202	5671-7142A	FILTER, CER S GB BB
539	CF203	5671-012A	FILTER, CER S
568	CF251	5671-7137C	FILTER, CER S
567	CF252	5671-0159	FILTER, CER S
711	CN1	4443-04501004	CONNECTOR
712	CN2	4443-04501007	CONNECTOR
705	ΔCN5	4443-040185	CONNECTOR
501	ΔFE101	6114-00401	FM TUNER
501B	FE101	6114-00402	FM TUNER GB BB
569	TC251	5371-93	TRIMMER, 1P
695	TM1	4214-122	TERMINAL
695	TM2	4214-122	TERMINAL
696	ΔTM3	4214-164	TERMINAL
042B	TM4	4214-167	TERMINAL GB BB
534	VR251	5101-10301934	RES, SEMI FIX 10K
595	VR301	5101-10401934	RES, SEMI FIX 100K
681	LCD1	5791-BP8A9041	LCD
047B	LUG1	4211-4	LUG GB BB
725	LUG2	4211-4	LUG BK
PCB-2 POWER SUPPLY P.C. BOARD			
CAPACITORS			
663	C13	5345-106F041	CAP, MINI ELE 10μ/50V
691	C15	5361-473ZF	CAP, CER .047μ
048B	C16	5361-223ZF	CAP, CER .022μ GB BB
051B	C17	5361-223ZF	CAP, CER .022μ GB BB
RESISTORS			
669	R12	5232-102J16P	RES, CBN 1/6P 1K
674	R13	5232-105J16P	RES, CBN 1/6P 1M
675	R14	5232-224J16P	RES, CBN 1/6P 220K
699	ΔR60	5135-33552	RES, CBN 1/2P 3.3M BK

Ser. No.	Ref. No.	Part No.	Description
DIODES			
666	ΔD12	5631-ISS133	DIODE, DET
666	D14	5631-ISS133	DIODE, DET
MISCELLANEOUS			
689	S1	4431-A02725	SWITCH, PUSH
689B	S1	4431-S0705102	SWITCH, PUSH (GB) (BB)
041B	ΔS2	4411-1047111	SWITCH, ROTARY (GB) (BB)
721	ΔT1	5584-S1804	XFORMER, POWER
721B	ΔT1	5584-S1805	XFORMER, POWER (GB) (BB)
701	JL1	4242-R0204101	JUMPER LEAD

PCB-3 UP/DOWN P.C.BOARD

Ser. No.	Ref. No.	Part No.	Description
DIODES			
630	D711	5631-ISS133	DIODE, DET
630	D712	5631-ISS133	DIODE, DET
630	D713	5631-ISS133	DIODE, DET
MISCELLANEOUS			
688	S711	4437-00604	SWITCH, PU-TC
688	S712	4437-00604	SWITCH, PU-TC
688	S713	4437-00604	SWITCH, PU-TC
713	CN3	4443-04401004	CONNECTOR

PCB-4 PRE SET P.C.BOARD

Ser. No.	Ref. No.	Part No.	Description
DIODES			
629	D701	5631-ISS133	DIODE, DET
629	D702	5631-ISS133	DIODE, DET
629	D703	5631-ISS133	DIODE, DET
629	D704	5631-ISS133	DIODE, DET
629	D705	5631-ISS133	DIODE, DET
629	D706	5631-ISS133	DIODE, DET
629	D707	5631-ISS133	DIODE, DET
629	D708	5631-ISS133	DIODE, DET
629	D709	5631-ISS133	DIODE, DET (BK) (BB)
629	D710	5631-ISS133	DIODE, DET (BK) (BB)
MISCELLANEOUS			
687	S701	4437-00604	SWITCH, PU-TC
687	S702	4437-00604	SWITCH, PU-TC
687	S703	4437-00604	SWITCH, PU-TC
687	S704	4437-00604	SWITCH, PU-TC
687	S705	4437-00604	SWITCH, PU-TC
687	S706	4437-00604	SWITCH, PU-TC
687	S707	4437-00604	SWITCH, PU-TC
687	S708	4437-00604	SWITCH, PU-TC
714	CN4	4443-04401007	CONNECTOR

PCB-5 LAMP P.C.BOARD

Ser. No.	Ref. No.	Part No.	Description
MISCELLANEOUS			
702	JL2	4242-R0103201	JUMPER LEAD
682	LPI	5731-00101140	LAMP
682	LP2	5731-00101140	LAMP

CHASSIS MISCELLANEOUS

Ser. No.	Ref. No.	Part No.	Description
MISCELLANEOUS			
047B		4211-4	LUG (GB) (BB)
719	ΔPI	4161-71147	CORD W/PLUG
719B	ΔPI	4161-7256	CORD W/PLUG (GB) (BB)

PACKAGE PARTS LIST

Ser. No.	Ref. No.	Part No.	Description
021B		1756-06303	LABEL (GB) (BB)
022B		1756-03108	LABEL (GB)
022C		1756-03111	LABEL (BB)
111		1221-867147	CARTON BOX
113		1222-7224	CUSHION
115		1223-R0120055	SOFT SHEET
116		1241-R0123350	POLYETHY BAG IB

Ser. No.	Ref. No.	Part No.	Description
117		1241-C1493	POLYETHY BAG SET
118		1111-J30299	OWNER GUIDE (BK)
118B		1111-J30300	OWNER GUIDE IB (GB) (BB)
119		1241-R0115300	POLYETHY BAG LOOP
120		1113-717004	OWNER CARD (BK)
120B		1111-J30235	OWNER GUIDE (GB) (BB)
121		1119-047	ATTACH SHEET
122		1119-01201	ATTACH SHEET
124		1119-0137	ATTACH SHEET (BK)
124B		1119-0135	ATTACH SHEET (GB) (BB)
683		1397-6	T FEEDER ANT T
684	L1	5911-235	ANT COIL, BC
720		4161-71184	CORD W/PLUG

ABBREVIATIONS IN PARTS LIST

CAPACITORS	RESISTORS
CAP, MINI ELE : Electrolytic	RES, CBN 1/6W : Carbon 1/6W
CAP, CER : Ceramic	RES, FUSE : Fuse
CAP, PPP : Polypropylene	RES, CEM 5P : Cement 5W
CAP, MYL : Mylar	RES, MTL 1P : Metal 1W
CAP, MCA : Mica	2.2K : 2.2kΩ
CAP, MINI BP : Bipolar	220 : 220Ω
CAP, ELE BP : Electrolytic Bipolar	TRANSISTORS
470μ : 470μF	XISTOR : Transistor
6800p : 6800pF	FET : Field Effect Transistor
.047μ : 0.047μF	CONTROLS
	RES, V CBN : Variable Carbon Resistor

NOTE

 SAFETY RELATED COMPONENT. USE ONLY EXACT REPLACEMENT PART AS SPECIFIED.

SCHEMATIC DIAGRAM (FM TUNER)

- For North America area model

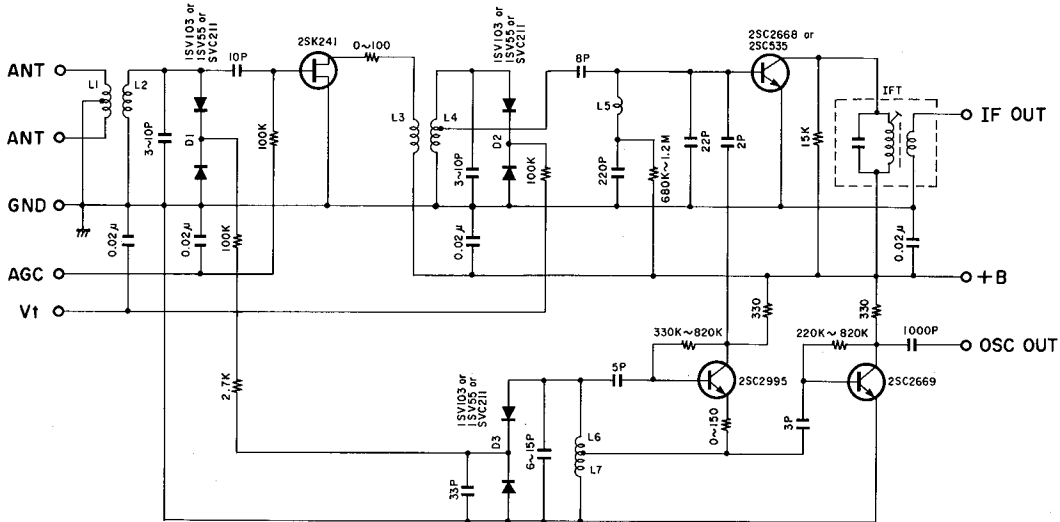

- For General and Australia models

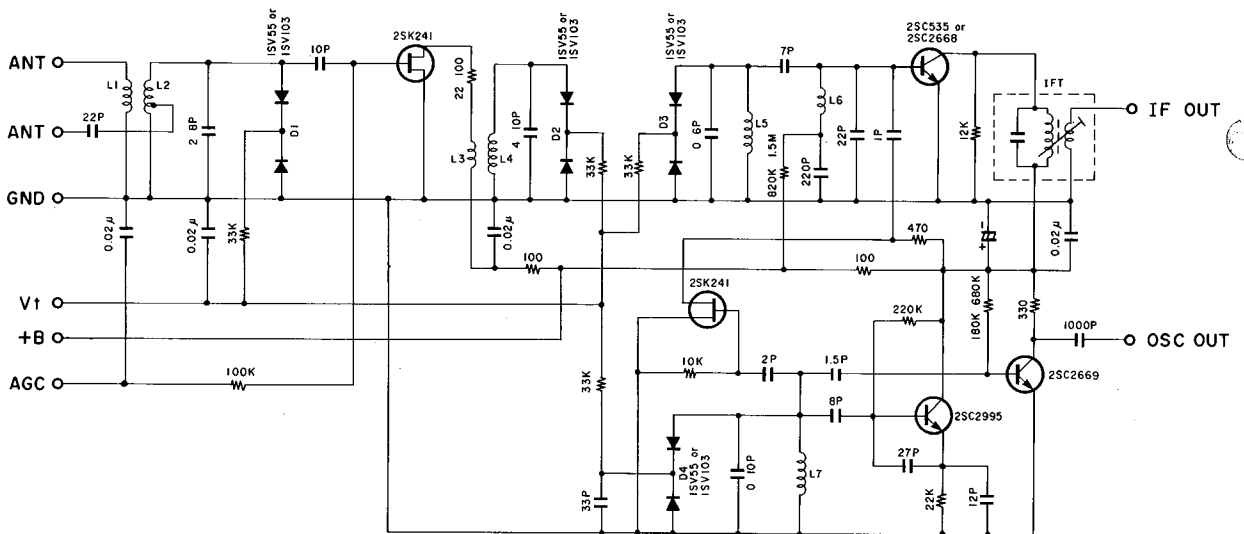

NOTE: Front End parts not available.
Schematic diagram supplied for reference only.

SCHEMATIC DIAGRAM (For North America area model)

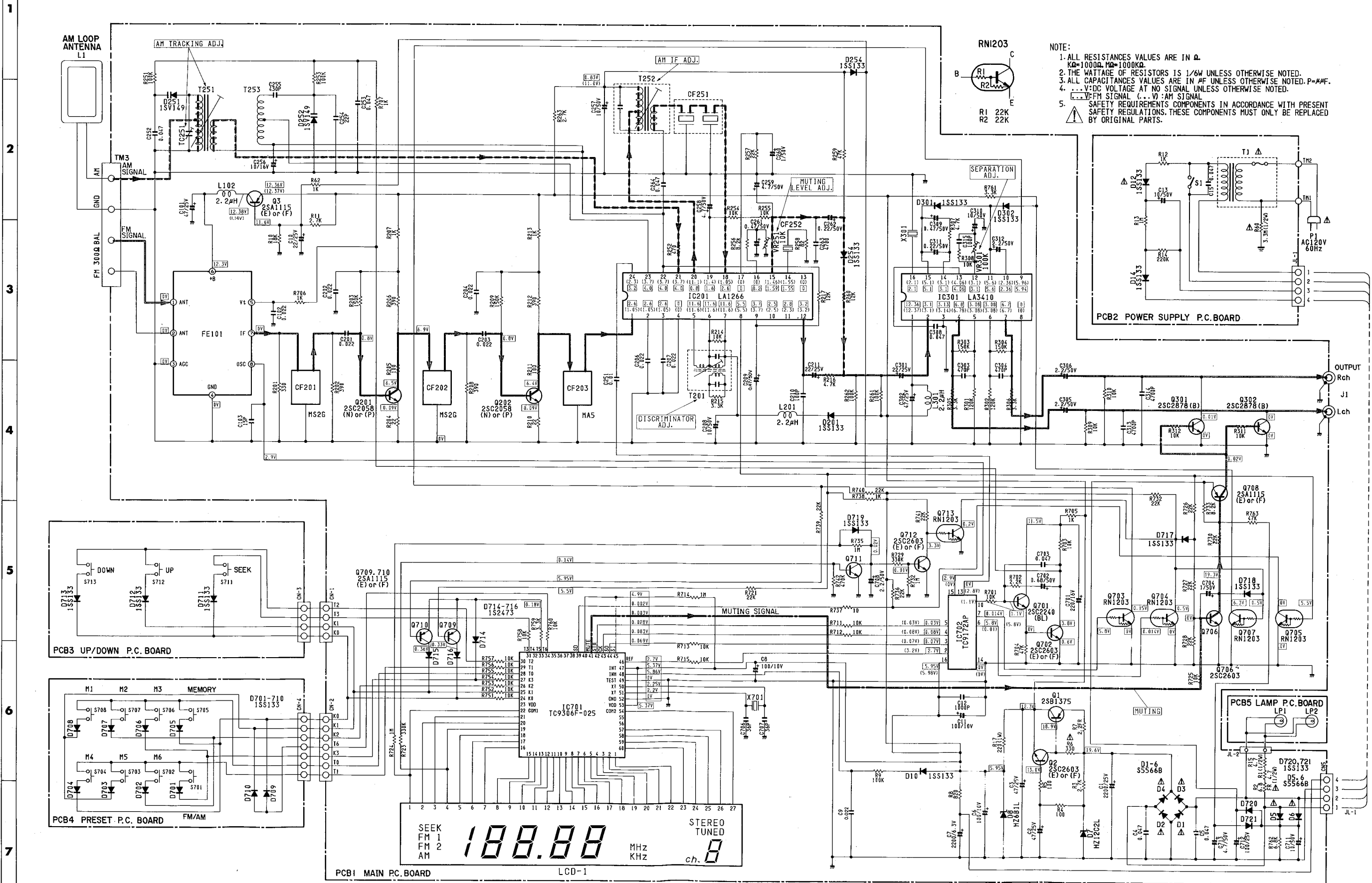

NOTE:
 1. ALL RESISTANCE VALUES ARE IN Ω .
 K Ω =1000 Ω , M Ω =1000K Ω .
 2. THE WATTAGE OF RESISTORS IS 1/6W UNLESS OTHERWISE NOTED.
 3. ALL CAPACITANCE VALUES ARE IN μ F UNLESS OTHERWISE NOTED. P=MMF.
 4. ... V:DC VOLTAGE AT NO SIGNAL UNLESS OTHERWISE NOTED.
 ... V:FM SIGNAL ... V:AM SIGNAL
 5. SAFETY REQUIREMENTS COMPONENTS IN ACCORDANCE WITH PRESENT SAFETY REGULATIONS. THESE COMPONENTS MUST ONLY BE REPLACED BY ORIGINAL PARTS.

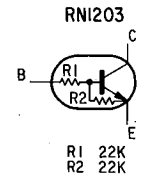

1
2
3
4
5
6
7

SCHEMATIC DIAGRAM (For North America area model)

1
2
3
4
5
6
7

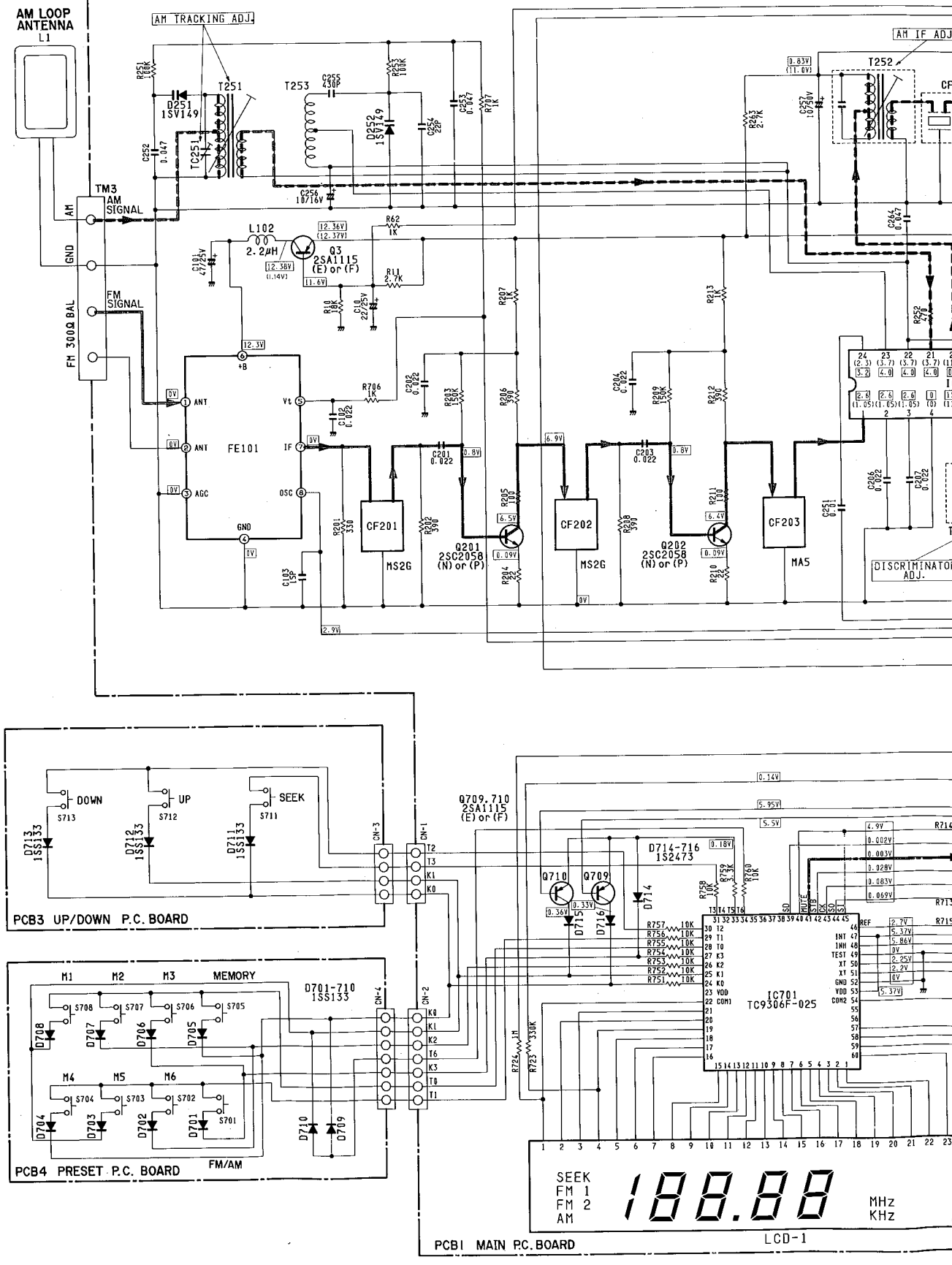

F

G

H

I

J

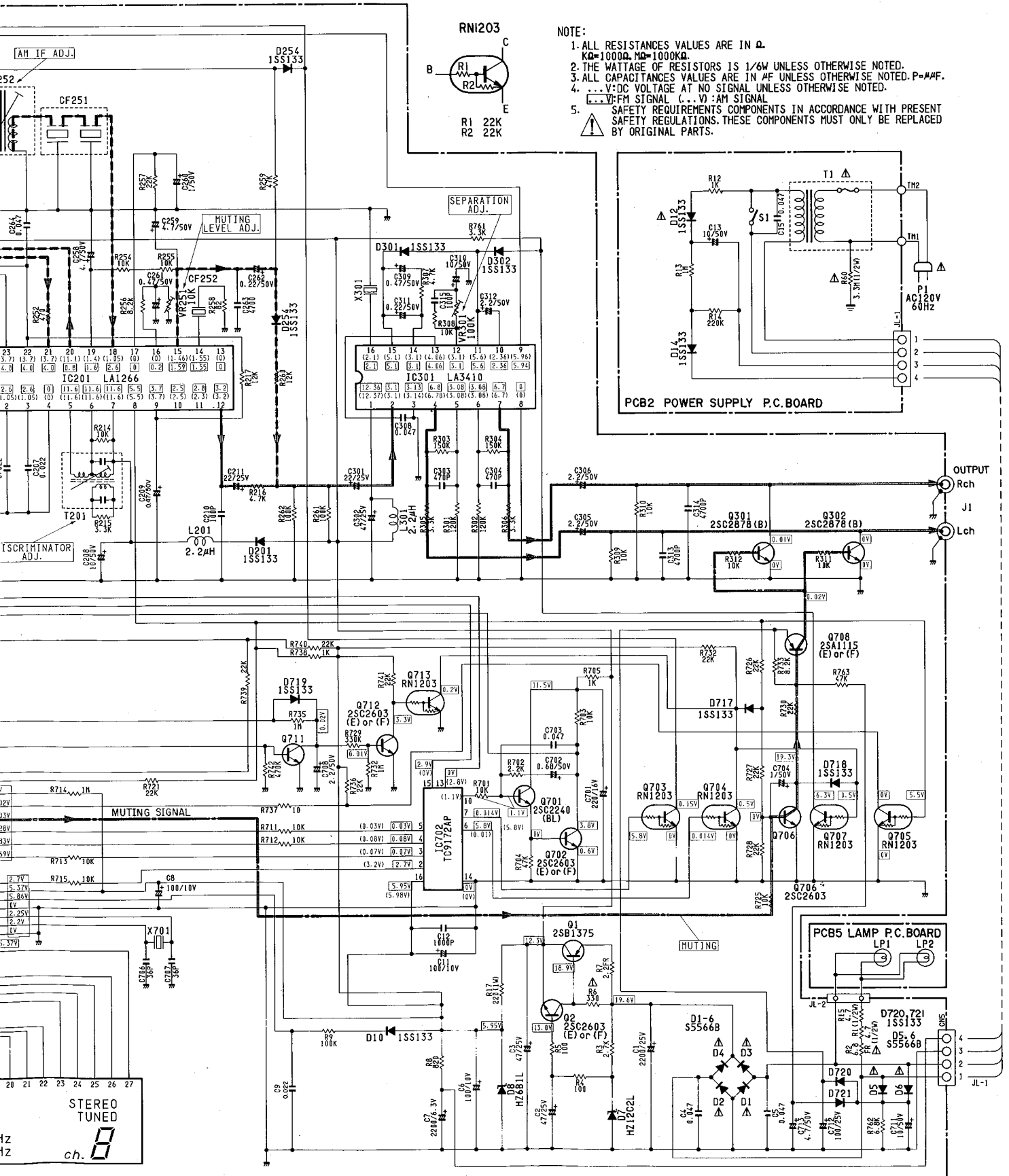

RN1203

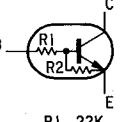

R1 22K
R2 22K

NOTE:

- 1. ALL RESISTANCES VALUES ARE IN Ω .
K Ω =1000 Ω . M Ω =1000K Ω .
- 2. THE WATTAGE OF RESISTORS IS 1/6W UNLESS OTHERWISE NOTED.
- 3. ALL CAPACITANCES VALUES ARE IN μ F UNLESS OTHERWISE NOTED. P= μ F.
- 4. ...V:DC VOLTAGE AT NO SIGNAL UNLESS OTHERWISE NOTED.
- 5. ...V:FM SIGNAL (...V):AM SIGNAL



SAFETY REQUIREMENTS COMPONENTS IN ACCORDANCE WITH PRESENT SAFETY REGULATIONS. THESE COMPONENTS MUST ONLY BE REPLACED BY ORIGINAL PARTS.

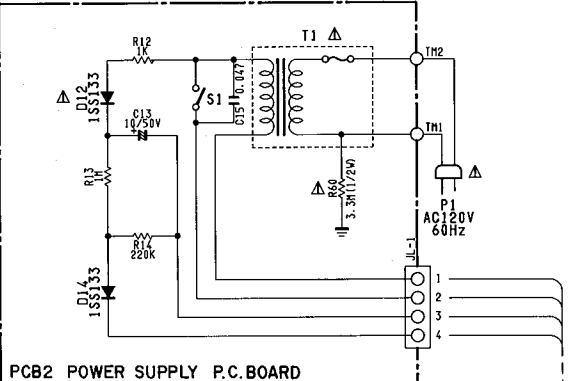

PCB2 POWER SUPPLY P.C. BOARD

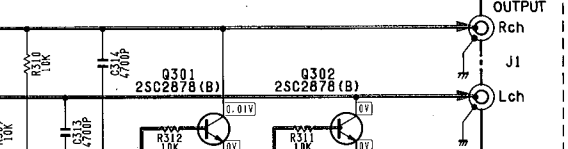

OUTPUT

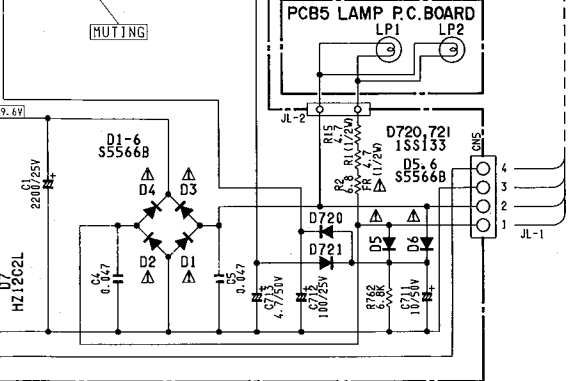
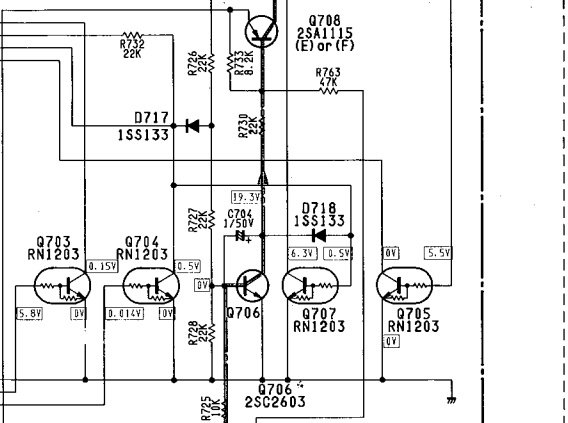

PCB5 LAMP P.C. BOARD

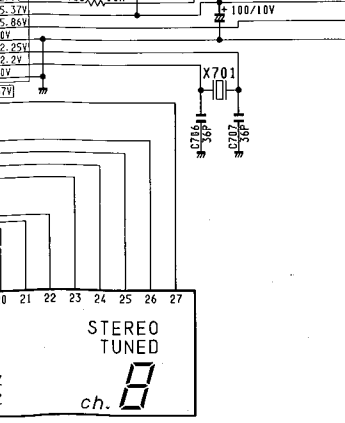
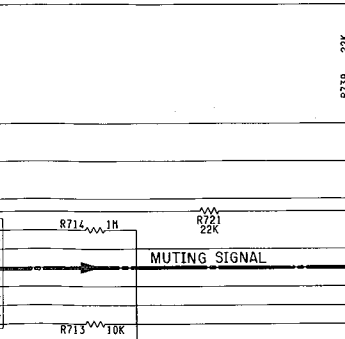
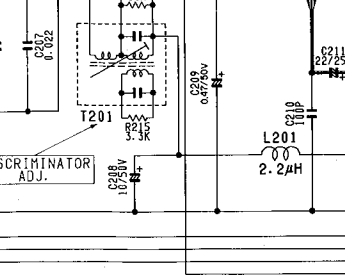
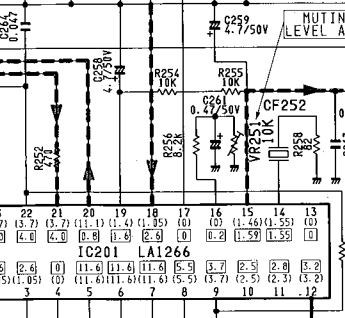
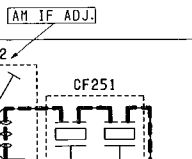

SCHEMATIC DIAGRAM (For General and Australia models)

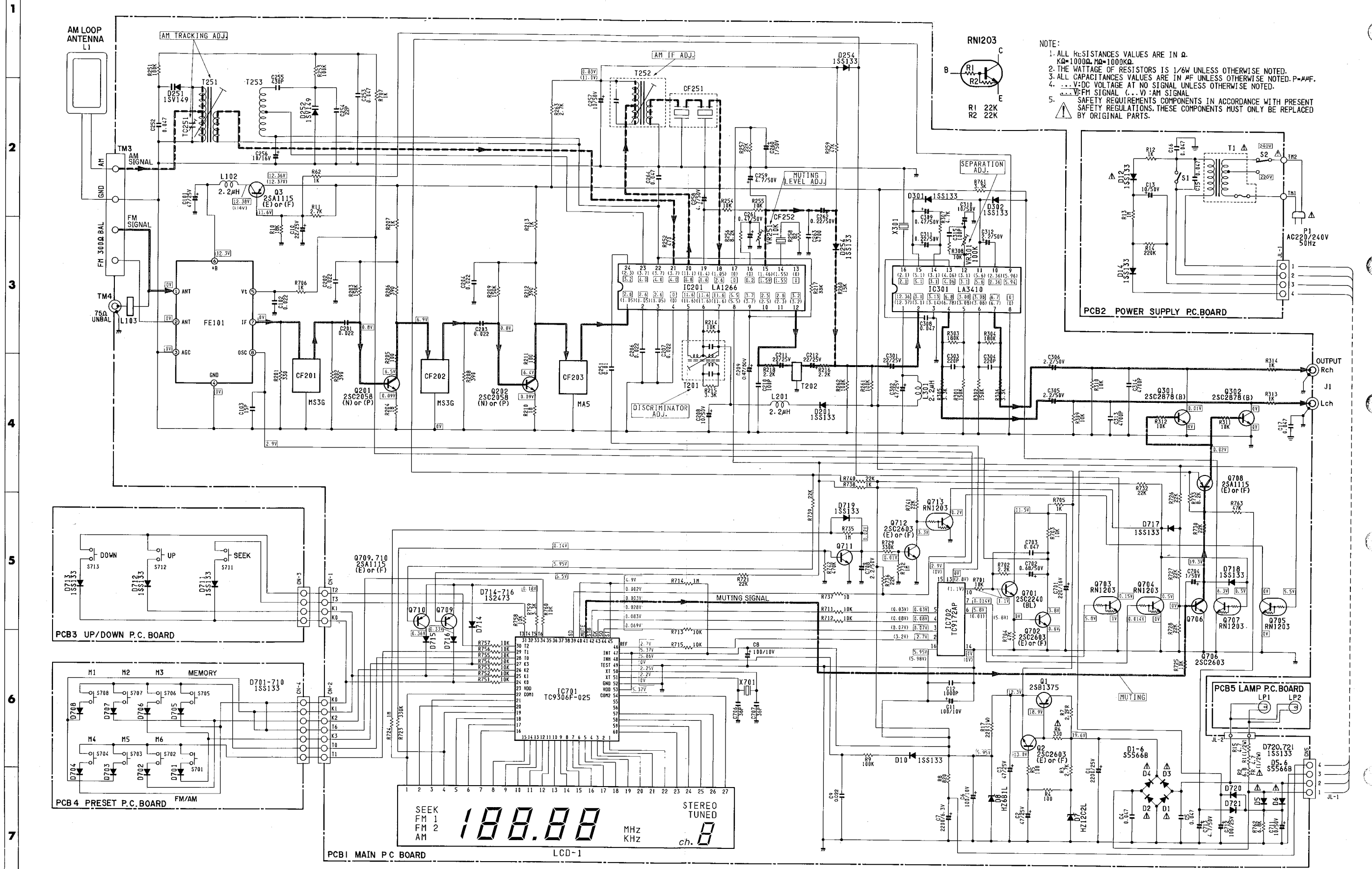

NOTE:

1. ALL RESISTANCES VALUES ARE IN Ω.
2. THE WATTAGE OF RESISTORS IS 1/6W UNLESS OTHERWISE NOTED.
3. ALL CAPACITANCES VALUES ARE IN pF UNLESS OTHERWISE NOTED. P=μF.
4. ...V:DC VOLTAGE AT NO SIGNAL UNLESS OTHERWISE NOTED.
5. ...V:FM SIGNAL (...):AM SIGNAL

SAFETY REQUIREMENTS COMPONENTS IN ACCORDANCE WITH PRESENT SAFETY REGULATIONS. THESE COMPONENTS MUST ONLY BE REPLACED BY ORIGINAL PARTS.

SCHEMATIC DIAGRAM (For General and Australia models)

1
2
3
4
5
6
7

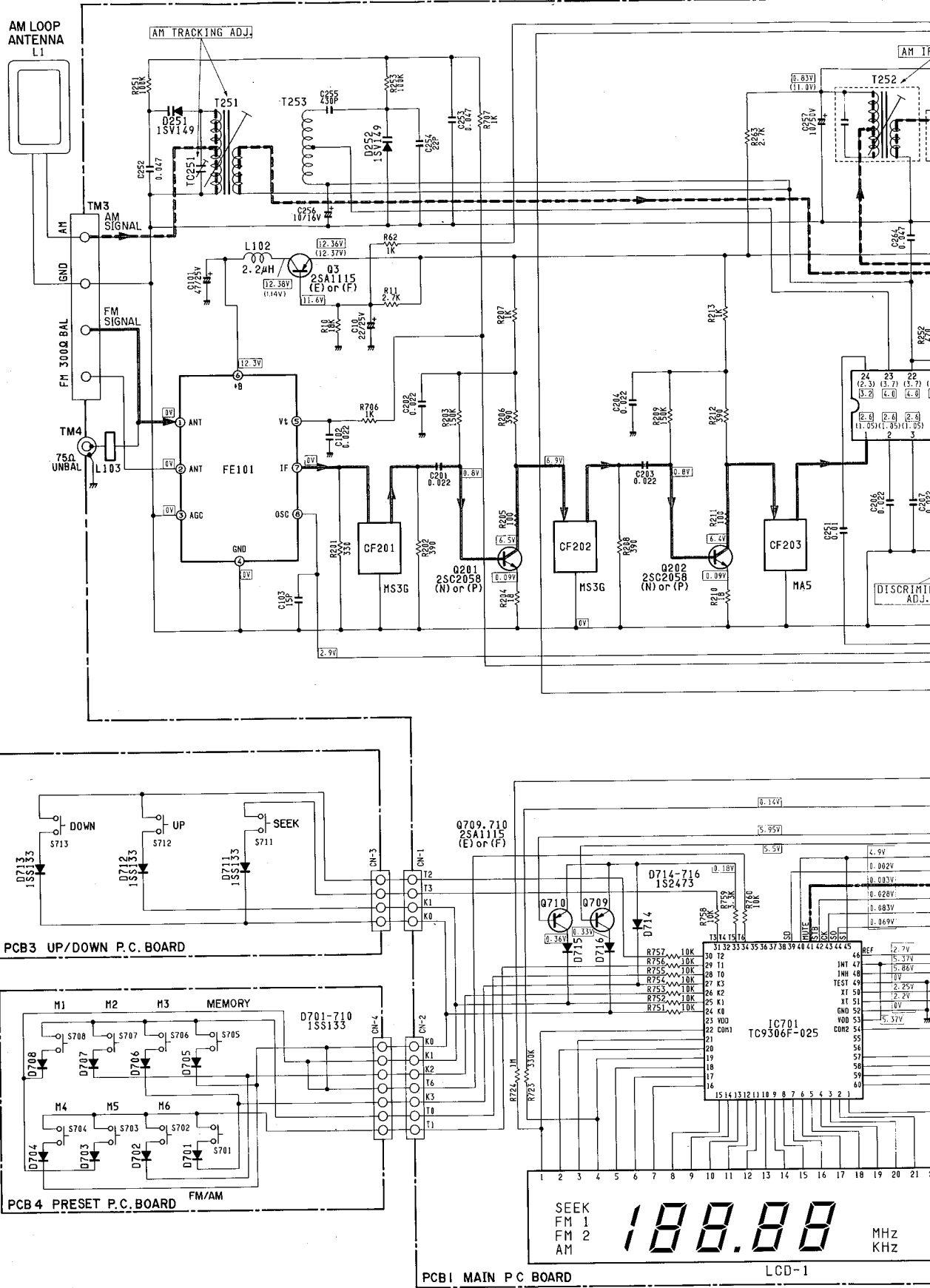

F

G

H

I

J

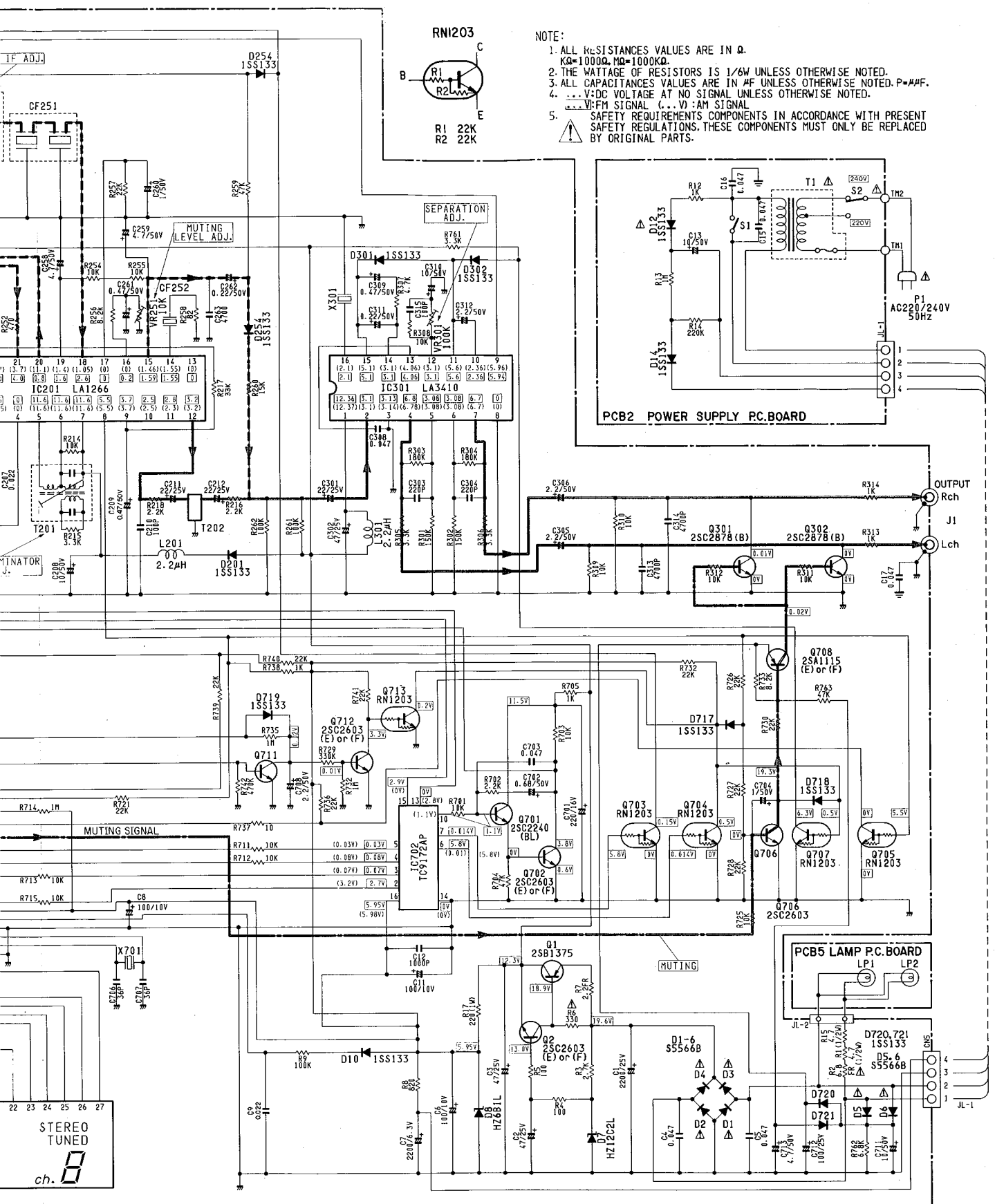

NOTE:

1. ALL RESISTANCE VALUES ARE IN Ω .
K Ω =1000 Ω , M Ω =1000K Ω .
 2. THE WATTAGE OF RESISTORS IS 1/4W UNLESS OTHERWISE NOTED.
 3. ALL CAPACITANCE VALUES ARE IN μ F UNLESS OTHERWISE NOTED. P= μ F.
 4. --- V:DC VOLTAGE AT NO SIGNAL UNLESS OTHERWISE NOTED.
 5. --- V:FM SIGNAL --- V:AM SIGNAL
- SAFETY REQUIREMENTS COMPONENTS IN ACCORDANCE WITH PRESENT SAFETY REGULATIONS, THESE COMPONENTS MUST ONLY BE REPLACED BY ORIGINAL PARTS.

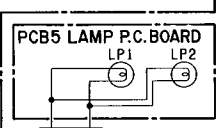
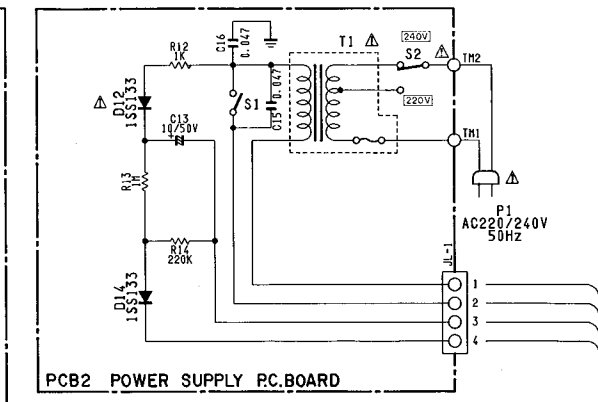
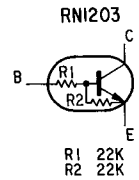

STEREO TUNED
ch.