

The Harman Kardon Model TU910

Manual No. 76A

LINEAR PHASE STEREO FM/AM TUNER

Technical Manual



harman/kardon
240 CROSSWAYS PARK WEST, WOODBURY, N.Y. 11797
1112-H15276A0 P-08845 1650 PRINTED IN JAPAN

TU910

SPECIFICATIONS

● **FM SECTION**

	Nominal	Limit
Tuning Range	87.3 ~ 108.4 MHz	
50dB Quieting Sensitivity		
Mono	15.2dBf	≤ 18dBf
Stereo	37dBf	≤ 40dBf
Usable Sensitivity	10.2dBf (IHF)	≤ 15dBf
Image Ratio	56dB	≥ 50dB
IF Rejection	83dB	≥ 80dB
Spurious Response Rejection	88dB	≥ 80dB
Capture Ratio	1.1dB	≤ 2.0dB
Alternate Channel Selectivity	65dB	≥ 50dB
AM Rejection	54dB	≥ 45dB
Signal to Noise Ratio		
for U.S.A. & Canada models		
Mono	82dB	≥ 78dB
Stereo	73dB	≥ 70dB
for General model		
Mono	76dB	≥ 72dB
Stereo	67dB	≥ 64dB
Total Harmonic Distortion		
Mono	0.06%	≤ 0.15%
Stereo	0.1%	≤ 0.3%
Stereo Separation at 1kHz		
for U.S.A. & Canada models	57dB	≥ 45dB
for General model	57dB	≥ 40dB
Output Level/Impedance (Stereo)	775mV/2.2kΩ	

● **AM SECTION**

	Nominal	Limit
Tuning Range	515 ~ 1,680 kHz	
Usable Sensitivity		
External Antenna	9μV	≤ 20μV
Loop Antenna	220μV/m	
Selectivity	53dB	≥ 35dB
Signal to Noise Ratio	53dB	≥ 50dB
Image Rejection	44dB	≥ 38dB
IF Rejection	70dB	≥ 50dB

● **DIMENSIONS (W x H x D)** 17-1/2"x2-11/16"x14-11/16"

(443 x 68 x 372 mm)

● **WEIGHT**

8 lbs. 3 oz. (3.7 kg)

● **POWER SUPPLIES**

for U.S.A. & Canada models	AC 120V, 60Hz
for General model	AC 100/120/220/240V, 50/60Hz

● **POWER CONSUMPTION**

18W

This specification is the target of servicing. But, there is a case that the specification is not applicable to the measurement condition and instrument.

Specifications and components subject to change without notice. Overall performance will be maintained or improved.

LEAKAGE TEST (FOR SERVICE ENGINEERS IN THE U.S.A.)

Before returning the unit to the user, perform the following safety checks:

1. Inspect all lead dress to make certain that leads are not pinched or that hardware is not lodged between the chassis and other metal parts in the unit.
2. Be sure that any protective devices such as nonmetallic control knobs, insulating fishpapers, cabinet backs, adjustment and compartment covers or shields, isolation resistor-capacity networks, mechanical insulators, etc. which were removed for servicing are properly reinstalled.
3. Be sure that no shock hazard exists; check for leakage current using Simpson Model 229 Leakage Tester, standard equipment item No. 21641, RCA Model WT540A or use alternate method as follows:

Plug the power cord directly into a 120-volt AC receptacle (do not use an Isolation Transformer for this test). Using two clip leads, connect a 1500 Ohm, 10-watt resistor paralleled by a 0.15μF capacitor, in series with all exposed metal cabinet parts and a known earth ground, such as a water pipe or conduit. Use a VTVM or VOM with 1000 Ohms per volt, or higher, sensitivity to measure the AC voltage drop across the resistor. (See Diagram.) Move the resistor connection to each exposed metal part having a return path to the chassis (antenna, metal, cabinet, screw heads, knobs and control shafts, escutcheon, etc.) and measure the AC voltage drop across the resistor. (This test should be performed with the power switch in both the On and Off positions.)

A reading of 0.35 volt RMS or more is excessive and indicates a potential shock hazard which must be corrected before returning the unit to the owner.

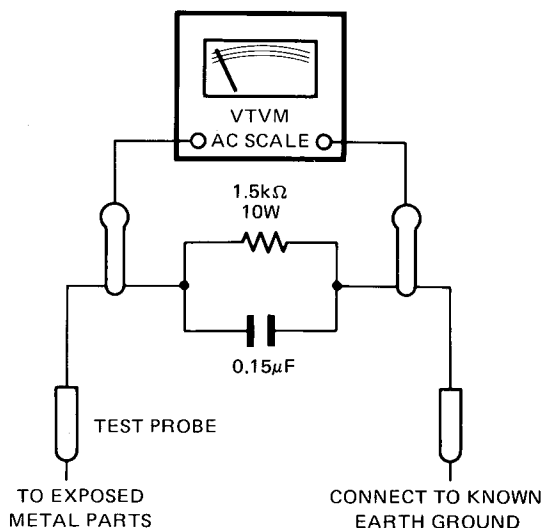
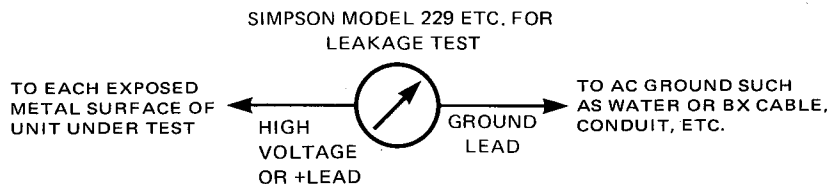

ALIGNMENT PROCEDURES (REFER TO PAGES 13 AND 14)

AM ALIGNMENT

- Conditions: ●Set the Function selector to the "am" position.
●Standard modulation of the AM Signal Generator is 400Hz at 30%.

Step	Alignment	Connection Equipments	Measurement Frequency	Dial Setting	Adjustment	For
1	IF	●Connect the AM Test Loop Antenna cable into the output jack of AM IF Sweep Generator. Place AM Test Loop Antenna close enough to couple signal into the AM Antenna (L1). ●Connect the cable from input jack of AM IF Sweep Generator to TP1 and TP2 (ground).	450kHz	Maximum frequency	T251, T252	Maximum output level and symmetrical curve on scope.
2	Tuning Range	●Connect the AM Test Loop Antenna cable into the output jack of AM Signal Generator. Place AM Test Loop Antenna close enough to couple signal into the AM Antenna (L1). Make the signal as weak as possible. ●Connect the VTVM and Oscilloscope to the Fixed Output jacks.	1680kHz	Maximum frequency	TC252	Maximum output
3			515kHz	Minimum frequency	L252	
4			Repeat steps 2 and 3 for optimum sensitivity.			
5	Tracking	●Connect the VTVM and Oscilloscope to the Fixed Output jacks.	1400kHz	1400kHz	TC251	Maximum output (When the dial pointer is set to the center of the range in which the Signal Strength indicator lights.)
6			600kHz	600kHz	L251	
7			Repeat steps 5 and 6 for optimum sensitivity.			

FM ALIGNMENT

- Conditions: ●After the Power switch is pushed on, wait for 5 minutes before adjusting so that the most stable operation is obtained.
●Before adjusting, short the TP(A) and TP(B).
●Set the Function selector to the "stereo fm" position.
●Depress the Muting switch to the "off" position.
●Depress the High Blend switch (button in).

FM Signal Generator Standard Modulation

U.S.A. & Canada models	General model
1kHz, 100% modulation	1kHz, 53% modulation

Step	Alignment	Connection Equipments	Measurement Frequency	Dial Setting	Adjustment	For
1	IF	●Connect the VTVM to the Fixed Output jack.			T101	Maximum noise
2	Tuning Range	●Connect the FM Signal Generator to FM 300Ω BAL Antenna terminals through the 300Ω balanced dummy. ●Connect the VTVM to the Fixed Output jack.	87.3MHz	Minimum frequency	L105	Maximum output with weak input signal.
3			108.4MHz	Maximum frequency	TC103	
4			Repeat steps 2 and 3 for optimum sensitivity.			
5	Tracking	●Connect the VTVM to the Fixed Output jack.	90MHz	90MHz	L102, L103	Maximum output with weak input signal.
6			106MHz	106MHz	TC101, TC102	
7			Repeat steps 5 and 6 for optimum sensitivity.			
8	Discriminator	●Connect the Oscilloscope and Distortion Meter to the Fixed Output jack.	98MHz	98MHz		Obtain intune with weak input signal.
9			98MHz	98MHz	T201(A)	Adjust so that the color of the dial illumination changes from orange to green when the output frequency of the FM Signal Generator is shifted to low frequency side and high frequency side by the same but limited amount both from 98MHz (1mV).
10			98MHz	98MHz	T201(B)	Minimum distortion
11			Repeat steps 9 and 10 for optimum sensitivity.			
12	AFC-ON					Open the TP(A) and TP(B).
13	Meter Voltage	●Connect the DC, Volt Meter to the TP3 and TP2 (ground).	98MHz	98MHz	VR201	Center position of VR201 adjustment range.
14			98MHz	98MHz	VR202	11V on DC Volt Meter at 1mV input.
15	Intune		98MHz	98MHz	VR352	Adjust so that the color of dial illumination changes from orange to green with 15μV input.

FM MPX ALIGNMENT

- Conditions: ●Set the Function selector to the "stereo fm" position.

	U.S.A. & Canada models	General model
FM Signal Generator	1kHz, 100% modulation	1kHz, 53% modulation
Stereo Modulator	L+R=45.5%, L-R=45.5%, 19kHz=9%	L+R=22.5%, L-R=22.5%, 19kHz=8%

Step	Alignment	Connection Equipments	Measurement Frequency	Dial Setting	Adjustment	For
1	Free Run	●Connect the Stereo Modulator to FM Signal Generator. Connect FM Signal Generator to FM 300Ω BAL Antenna terminals through the 300Ω balanced dummy.	98MHz (unmodulation)	98MHz	VR151	19kHz ± 0.02kHz
2	Stereo Threshold	●Connect the Frequency Counter to the TP4 and TP2 (ground). ●Connect the Oscilloscope and VTVM to the Fixed Output jacks.	98MHz	98MHz	VR351	Stereo FM indicator lights at 30μV ± 2dB input.
3	SCA Cancel	●Connect the Stereo Modulator to FM Signal Generator. Connect FM Signal Generator to FM 300Ω BAL Antenna terminals through the 300Ω balanced dummy. Apply 67kHz, 10% FM modulation SCA signal to the SCA input jack of Stereo Modulator. ●Connect the VTVM and Oscilloscope to the Fixed Output jacks through 19kHz Low Pass Filter.	98MHz	98MHz	VR501	Minimum output at 1mV input. * With the General model, set the VR501 to the center.
4	Sub-carrier Rejection	●Connect the Stereo Modulator to FM Signal Generator. Apply Signal Generator output (1mV) to FM 300Ω BAL Antenna terminals through the 300Ω balanced dummy. ●Connect the Oscilloscope and the VTVM to the Fixed Output jacks.	98MHz	98MHz	VR152	Minimum output at 19kHz pilot signal only by Stereo Modulator.
5	Separation	●Connect the Stereo Modulator to FM Signal Generator. Apply Signal Generator output (1mV) to FM 300Ω BAL Antenna terminals through the 300Ω balanced dummy. ●Connect the VTVM and Oscilloscope to the Fixed Output jacks through 19kHz Low Pass Filter.	98MHz	98MHz	VR304	Set the VR304 to the center.
					VR503	Adjust so that the right channel output becomes minimum when only the left channel of the Stereo Modulator is modulated.
6	Separation Balance		98MHz	98MHz	VR503	Adjust so that the left channel output becomes minimum when only the right channel of the Stereo Modulator is modulated.
					VR304	With the VR304, correct unbalance between minimum outputs the right and left channels.

ALIGNMENT PROCEDURES (REFER TO PAGES 13 AND 14)

AM ALIGNMENT

- Conditions: ●Set the Function selector to the "am" position.
●Standard modulation of the AM Signal Generator is 400Hz at 30%.

Step	Alignment	Connection Equipments	Measurement Frequency	Dial Setting	Adjustment	For
1	IF	<ul style="list-style-type: none"> Connect the AM Test Loop Antenna cable into the output jack of AM IF Sweep Generator. Place AM Test Loop Antenna close enough to couple signal into the AM Antenna (L1). Connect the cable from input jack of AM IF Sweep Generator to TP1 and TP2 (ground). 	450kHz	Maximum frequency	T251, T252	Maximum output level and symmetrical curve on scope.
2	Tuning Range	<ul style="list-style-type: none"> Connect the AM Test Loop Antenna cable into the output jack of AM Signal Generator. Place AM Test Loop Antenna close enough to couple signal into the AM Antenna (L1). Make the signal as weak as possible. Connect the VTVM and Oscilloscope to the Fixed Output jacks. 	1680kHz	Maximum frequency	TC252	Maximum output
3			515kHz	Minimum frequency	L252	
4			Repeat steps 2 and 3 for optimum sensitivity.			
5	Tracking		1400kHz	1400kHz	TC251	Maximum output (When the dial pointer is set to the center of the range in which the Signal Strength indicator lights.)
6			600kHz	600kHz	L251	
7			Repeat steps 5 and 6 for optimum sensitivity.			

FM ALIGNMENT

- Conditions: ●After the Power switch is pushed on, wait for 5 minutes before adjusting so that the most stable operation is obtained.
●Before adjusting, short the TP(A) and TP(B).
●Set the Function selector to the "stereo fm" position.
●Depress the Muting switch to the "off" position.
●Depress the High Blend switch (button in).

FM Signal Generator Standard Modulation

U.S.A. & Canada models	General model
1kHz, 100% modulation	1kHz, 53% modulation

Step	Alignment	Connection Equipments	Measurement Frequency	Dial Setting	Adjustment	For
1	IF	<ul style="list-style-type: none"> Connect the VTVM to the Fixed Output jack. 			T101	Maximum noise
2	Tuning Range	<ul style="list-style-type: none"> Connect the FM Signal Generator to FM 300Ω BAL Antenna terminals through the 300Ω balanced dummy. Connect the VTVM to the Fixed Output jack. 	87.3MHz	Minimum frequency	L105	Maximum output with weak input signal.
3			108.4MHz	Maximum frequency	TC103	
4			Repeat steps 2 and 3 for optimum sensitivity.			
5	Tracking		90MHz	90MHz	L102, L103	Maximum output with weak input signal.
6			106MHz	106MHz	TC101, TC102	
7			Repeat steps 5 and 6 for optimum sensitivity.			
8	Discriminator	<ul style="list-style-type: none"> Connect the Oscilloscope and Distortion Meter to the Fixed Output jack. 	98MHz	98MHz		Obtain intune with weak input signal.
9			98MHz	98MHz	T201(A)	Adjust so that the color of the dial illumination changes from orange to green when the output frequency of the FM Signal Generator is shifted to low frequency side and high frequency side by the same but limited amount both from 98MHz (1mV).
10			98MHz	98MHz	T201(B)	Minimum distortion
11			Repeat steps 9 and 10 for optimum sensitivity.			
12			AFC-ON	Open the TP(A) and TP(B).		
13	Meter Voltage	<ul style="list-style-type: none"> Connect the DC, Volt Meter to the TP3 and TP2 (ground). 	98MHz	98MHz	VR201	Center position of VR201 adjustment range.
14			98MHz	98MHz	VR202	11V on DC Volt Meter at 1mV input.
15	Intune		98MHz	98MHz	VR352	Adjust so that the color of dial illumination changes from orange to green with 15μV input.

FM MPX ALIGNMENT

Conditions: ●Set the Function selector to the "stereo fm" position.

	U.S.A. & Canada models	General model
FM Signal Generator	1kHz, 100% modulation	1kHz, 53% modulation
Stereo Modulator	L+R=45.5%, L-R=45.5%, 19kHz=9%	L+R=22.5%, L-R=22.5%, 19kHz=8%

Step	Alignment	Connection Equipments	Measurement Frequency	Dial Setting	Adjustment	For
1	Free Run	<ul style="list-style-type: none"> Connect the Stereo Modulator to FM Signal Generator. Connect FM Signal Generator to FM 300Ω BAL Antenna terminals through the 300Ω balanced dummy. 	98MHz (unmodulation)	98MHz	VR151	19kHz ± 0.02kHz
2	Stereo Threshold	<ul style="list-style-type: none"> Connect the Frequency Counter to the TP4 and TP2 (ground). Connect the Oscilloscope and VTVM to the Fixed Output jacks. 	98MHz	98MHz	VR351	Stereo FM indicator lights at 30μV ± 2dB input.
3	SCA Cancel	<ul style="list-style-type: none"> Connect the Stereo Modulator to FM Signal Generator. Connect FM Signal Generator to FM 300Ω BAL Antenna terminals through the 300Ω balanced dummy. Apply 67kHz, 10% FM modulation SCA signal to the SCA input jack of Stereo Modulator. Connect the VTVM and Oscilloscope to the Fixed Output jacks through 19kHz Low Pass Filter. 	98MHz	98MHz	VR501	Minimum output at 1mV input. * With the General model, set the VR501 to the center.
4	Sub-carrier Rejection	<ul style="list-style-type: none"> Connect the Stereo Modulator to FM Signal Generator. Apply Signal Generator output (1mV) to FM 300Ω BAL Antenna terminals through the 300Ω balanced dummy. Connect the Oscilloscope and the VTVM to the Fixed Output jacks. 	98MHz	98MHz	VR152	Minimum output at 19kHz pilot signal only by Stereo Modulator.
5	Separation	<ul style="list-style-type: none"> Connect the Stereo Modulator to FM Signal Generator. Apply Signal Generator output (1mV) to FM 300Ω BAL Antenna terminals through the 300Ω balanced dummy. Connect the VTVM and Oscilloscope to the Fixed Output jacks through 19kHz Low Pass Filter. 	98MHz	98MHz	VR304	Set the VR304 to the center.
					VR503	Adjust so that the right channel output becomes minimum when only the left channel of the Stereo Modulator is modulated.
					VR503	Adjust so that the left channel output becomes minimum when only the right channel of the Stereo Modulator is modulated.
6	Separation Balance		98MHz	98MHz	VR304	With the VR304, correct unbalance between minimum outputs the right and left channels.

DISASSEMBLY PROCEDURES (REFER TO PAGES 8 AND 14)

1 CABINET TOP (131) REMOVAL

Remove 6 screws **A** and remove the Cabinet Top (131).

2 CABINET BOTTOM (132) REMOVAL

Remove 4 screws **B** and remove the Cabinet Bottom (132).

3 FRONT PANEL ASSEMBLY (101) REMOVAL

1. Remove the Cabinet Top (131). (Refer to step **1** .)
2. Remove 5 screws **C** and remove the Front Panel Assembly (101).

4 MAIN P.C. BOARD (PCB-1) REMOVAL

1. Remove the Cabinet Top (131). (Refer to step **1** .)
2. Loosen 2 screws **D** and pull out the Shaft (198) with the Knob Assembly (104).
3. Secure the dial string to the pulley by winding adhesive tape or vinyl tape.
4. Remove 13 screws **E** and hexagon nut **F** and remove the Main P.C. Board (PCB-1). If necessary, unsolder the lead wires.

DIAL CORD STRINGING

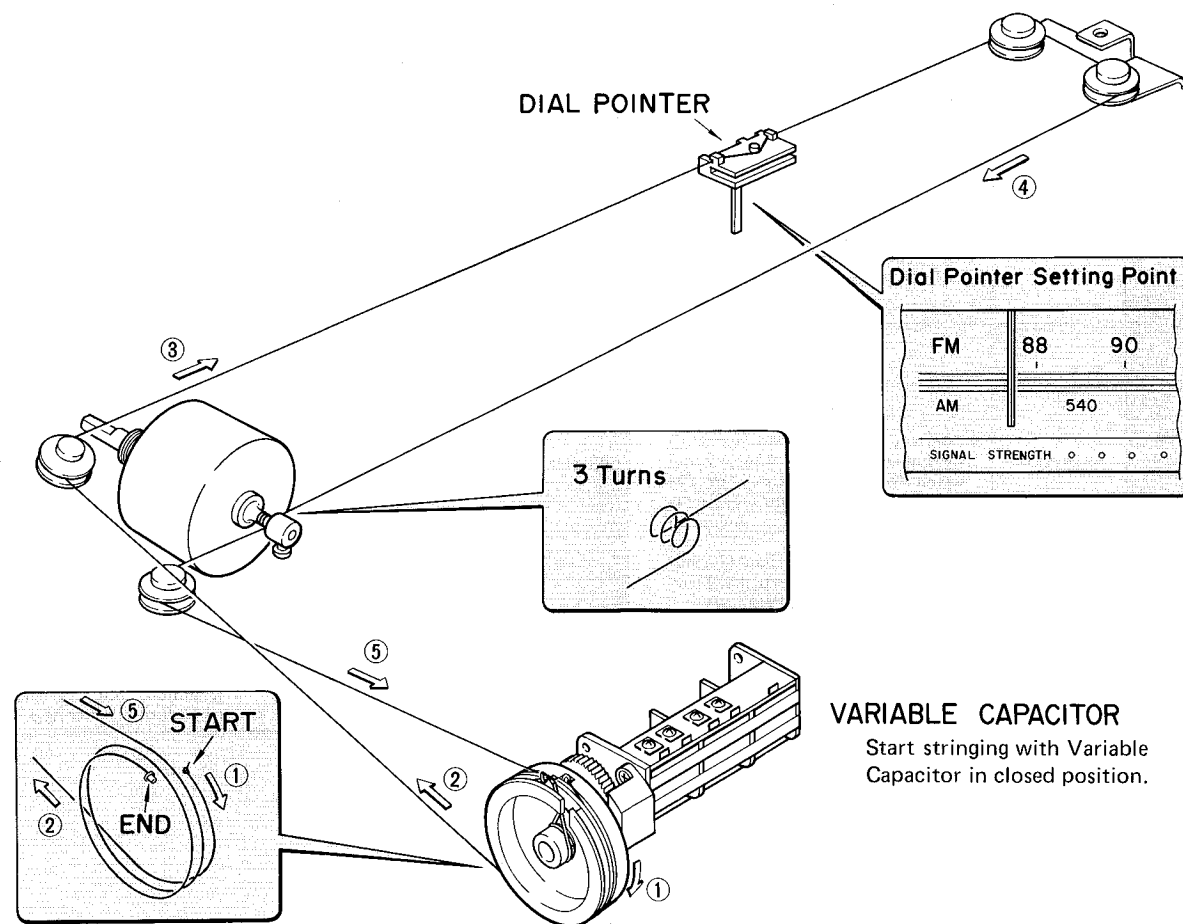

POWER CORD REPLACEMENT (FOR SERVICE ENGINEERS OTHER THAN NORTH AMERICA)

In order to prevent fire or shock hazard when replacing the power cord, follow the procedure below to replace the parts with the standard supply parts.

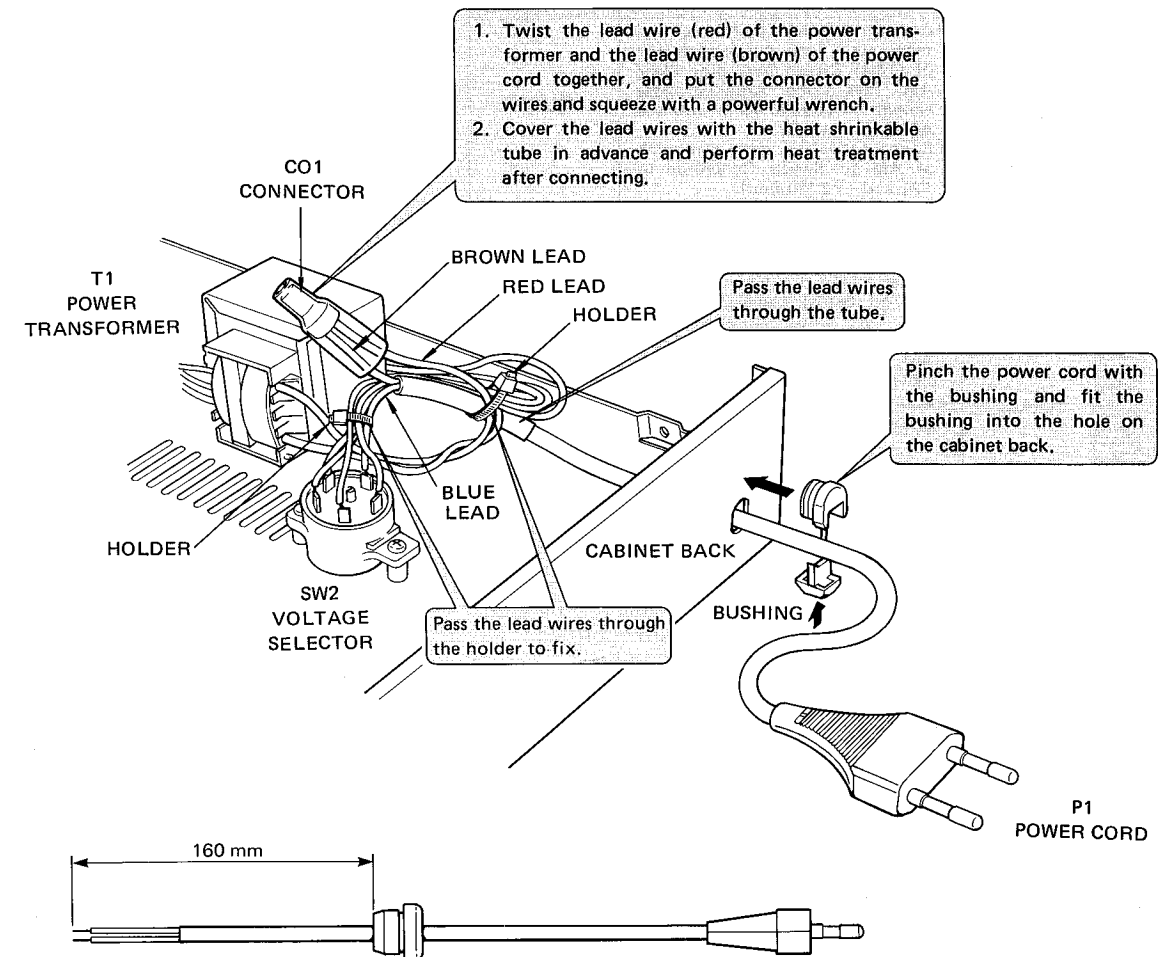

CIRCUIT DESCRIPTION

[1] SIGNAL PATH

The FM signal is amplified in the RF amp. Q101 of the front end and then mixed with the output of the local oscillator Q103 in Q102 and converted into a signal of the 10.7MHz intermediate frequency. The 10.7MHz signal is amplified in Q201 and Q202, and is fed to the ceramic filter CF201. Then the signal is amplified in Q203 and Q204, and is fed to ceramic filter CF202 and CF203. The signal is amplified in the triple IF limiter amplifiers of IC201 and it is detected in the quadrature. Then output signal is sampled and held by means of 38kHz signal produced in IC151 and it is fed to the audio power amplifier stages.

[2] MUTING OPERATION WHILE TUNING

The muting control voltage is taken out from ⑫ pin of IC201 and it is fed to the base of Q352. This causes Q352 to turn off, Q358 to become high level and muting gates Q320 (Lch) and Q319 (Rch) to become low level, thus muting operation is completed.

[3] SIGNAL INDICATOR CIRCUIT

1) FM tuner section

The signal indicator drive signal is taken out from ⑬ pin of IC201 and after passing through VR202, it is amplified in IC351 and fed to LED driver IC353.

2) AM tuner section

The signal indicator drive signal is taken out from ⑯ pin of IC251 and fed to IC351.

[4] TUNING INDICATOR CIRCUIT

In tune, the output of ③ pin of IC352 in the signal indicator circuit is fed to the base of Q359, and Q359 and Q360 become off and Q361 becomes on and then tuning indicator lamp illuminates in green color.

DISASSEMBLY PROCEDURES (REFER TO PAGES 8 AND 14)

1 CABINET TOP (131) REMOVAL

Remove 6 screws **A** and remove the Cabinet Top (131).

2 CABINET BOTTOM (132) REMOVAL

Remove 4 screws **B** and remove the Cabinet Bottom (132).

3 FRONT PANEL ASSEMBLY (101) REMOVAL

1. Remove the Cabinet Top (131). (Refer to step **1** .)
2. Remove 5 screws **C** and remove the Front Panel Assembly (101).

4 MAIN P.C. BOARD (PCB-1) REMOVAL

1. Remove the Cabinet Top (131). (Refer to step **1** .)
2. Loosen 2 screws **D** and pull out the Shaft (198) with the Knob Assembly (104).
3. Secure the dial string to the pulley by winding adhesive tape or vinyl tape.
4. Remove 13 screws **E** and hexagon nut **F** and remove the Main P.C. Board (PCB-1). If necessary, unsolder the lead wires.

DIAL CORD STRINGING

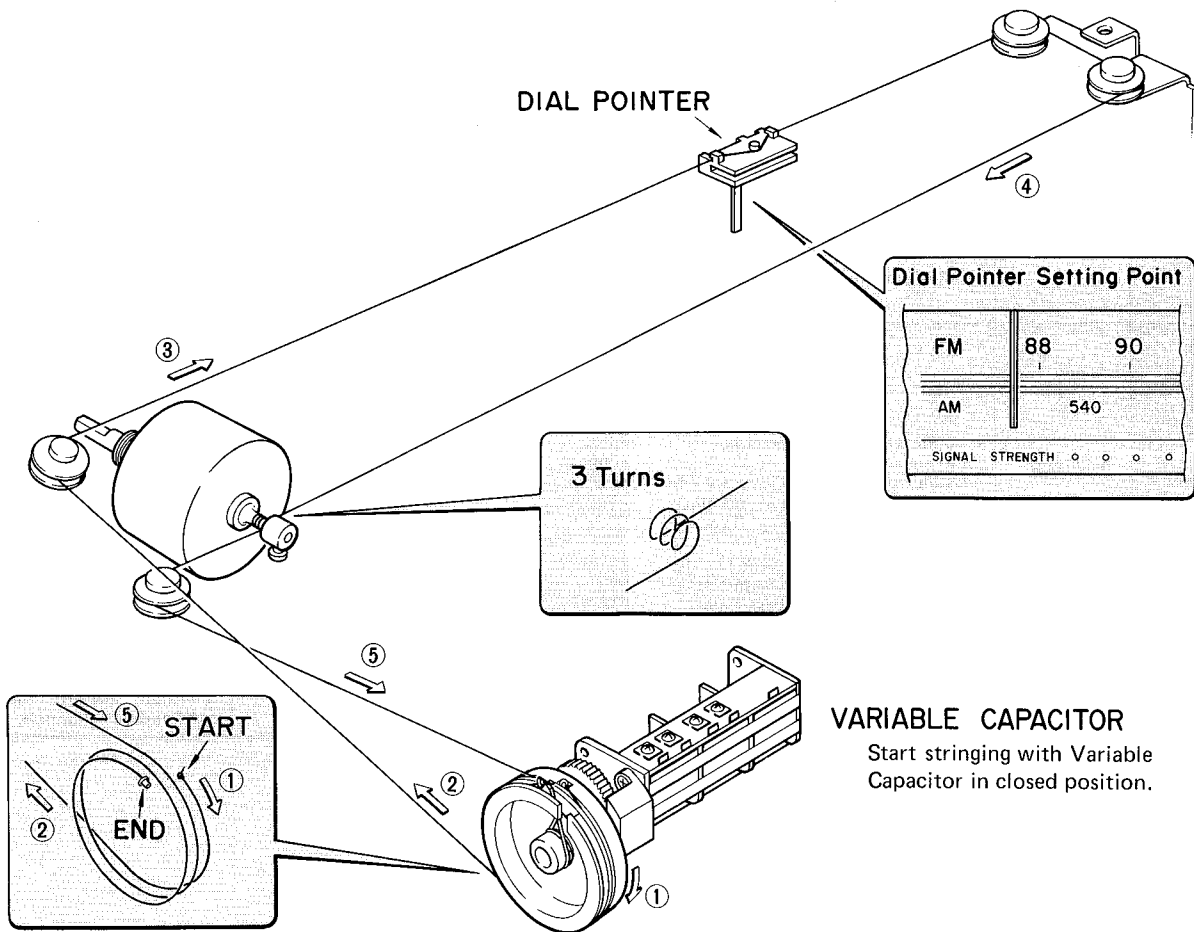

VARIABLE CAPACITOR
Start stringing with Variable Capacitor in closed position.

POWER CORD REPLACEMENT(FOR SERVICE ENGINEERS OTHER THAN NORTH AMERICA)

In order to prevent fire or shock hazard when replacing the power cord, follow the procedure below to replace the parts with the standard supply parts.

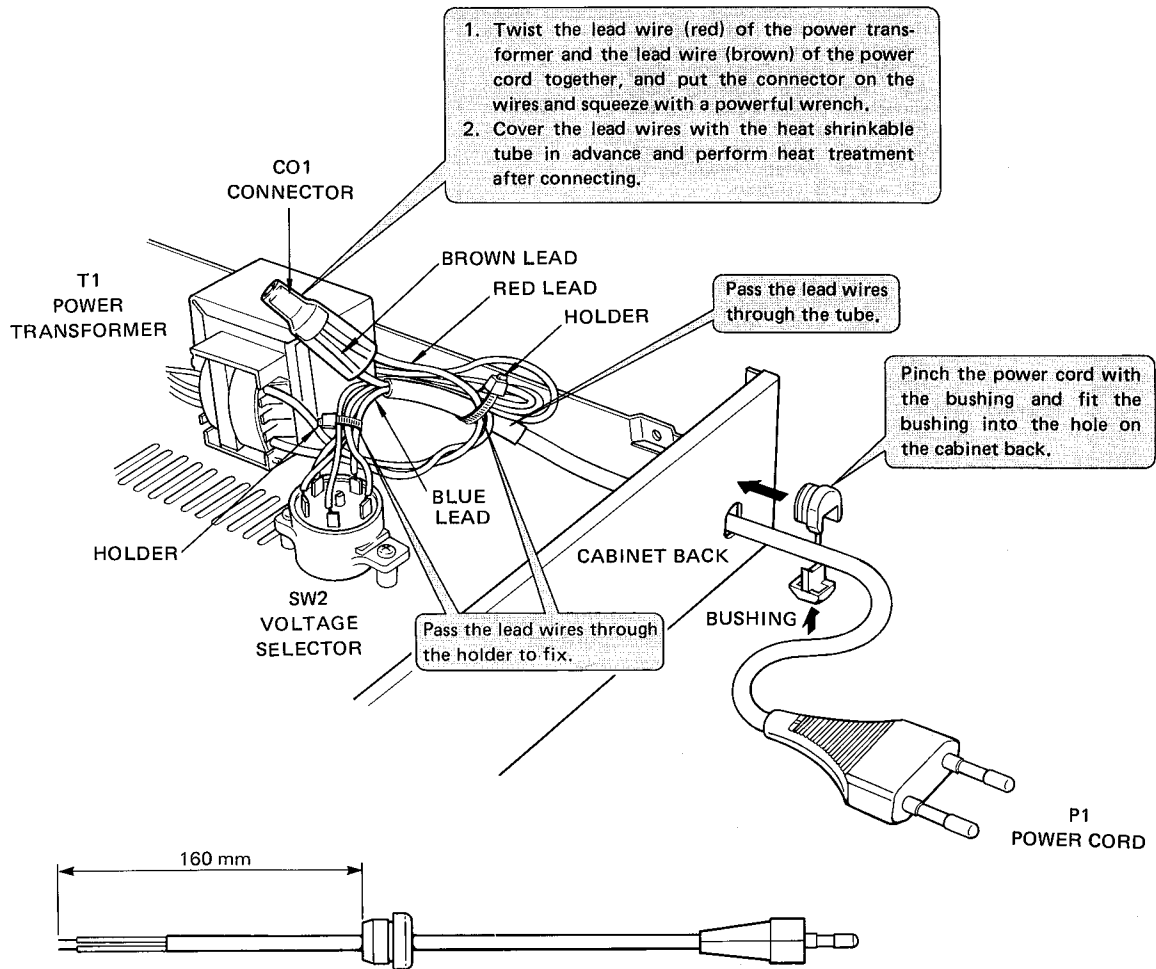

CIRCUIT DESCRIPTION

[1] SIGNAL PATH

The FM signal is amplified in the RF amp. Q101 of the front end and then mixed with the output of the local oscillator Q103 in Q102 and converted into a signal of the 10.7MHz intermediate frequency. The 10.7MHz signal is amplified in Q201 and Q202, and is fed to the ceramic filter CF201. Then the signal is amplified in Q203 and Q204, and is fed to ceramic filter CF202 and CF203. The signal is amplified in the triple IF limiter amplifiers of IC201 and it is detected in the quadrature. Then output signal is sampled and holded by means of 38kHz signal produced in IC151 and it is fed to the audio power amplifier stages.

[2] MUTING OPERATION WHILE TUNING

The muting control voltage is taken out from ⑫ pin of IC201 and it is fed to the base of Q352. This causes Q352 to turn off, Q358 to become high level and muting gates Q320 (Lch) and Q319 (Rch) to become low level, thus muting operation is completed.

[3] SIGNAL INDICATOR CIRCUIT

1) FM tuner section

The signal indicator drive signal is taken out from ⑬ pin of IC201 and after passing through VR202, it is amplified in IC351 and fed to LED driver IC353.

2) AM tuner section

The signal indicator drive signal is taken out from ⑬ pin of IC251 and fed to IC351.

[4] TUNING INDICATOR CIRCUIT

In tune, the output of ③ pin of IC352 in the signal indicator circuit is fed to the base of Q359, and Q359 and Q360 become off and Q361 becomes on and then tuning indicator lamp illuminates in green color.

BLOCK DIAGRAM

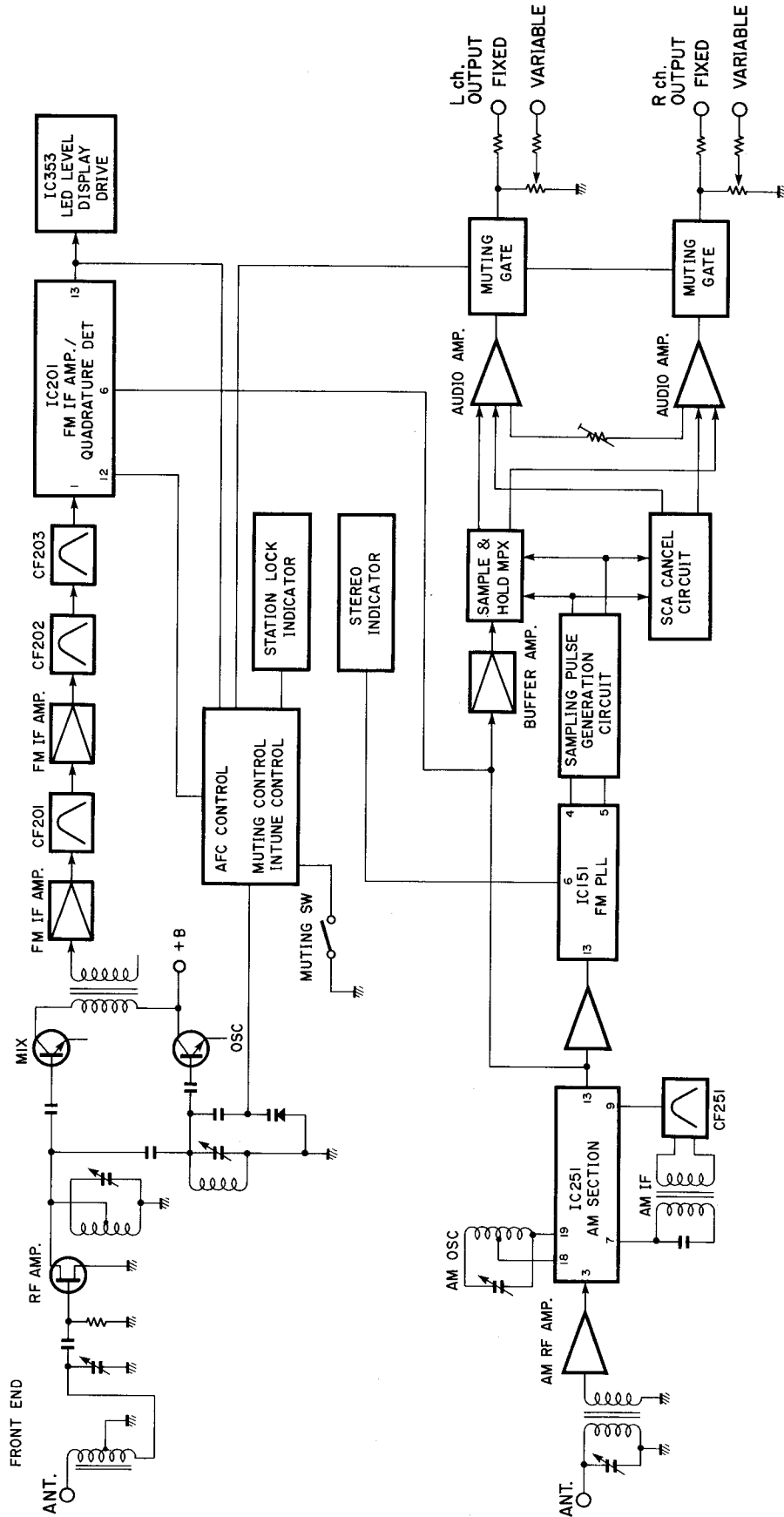

GENERAL UNIT EXPLODED VIEW

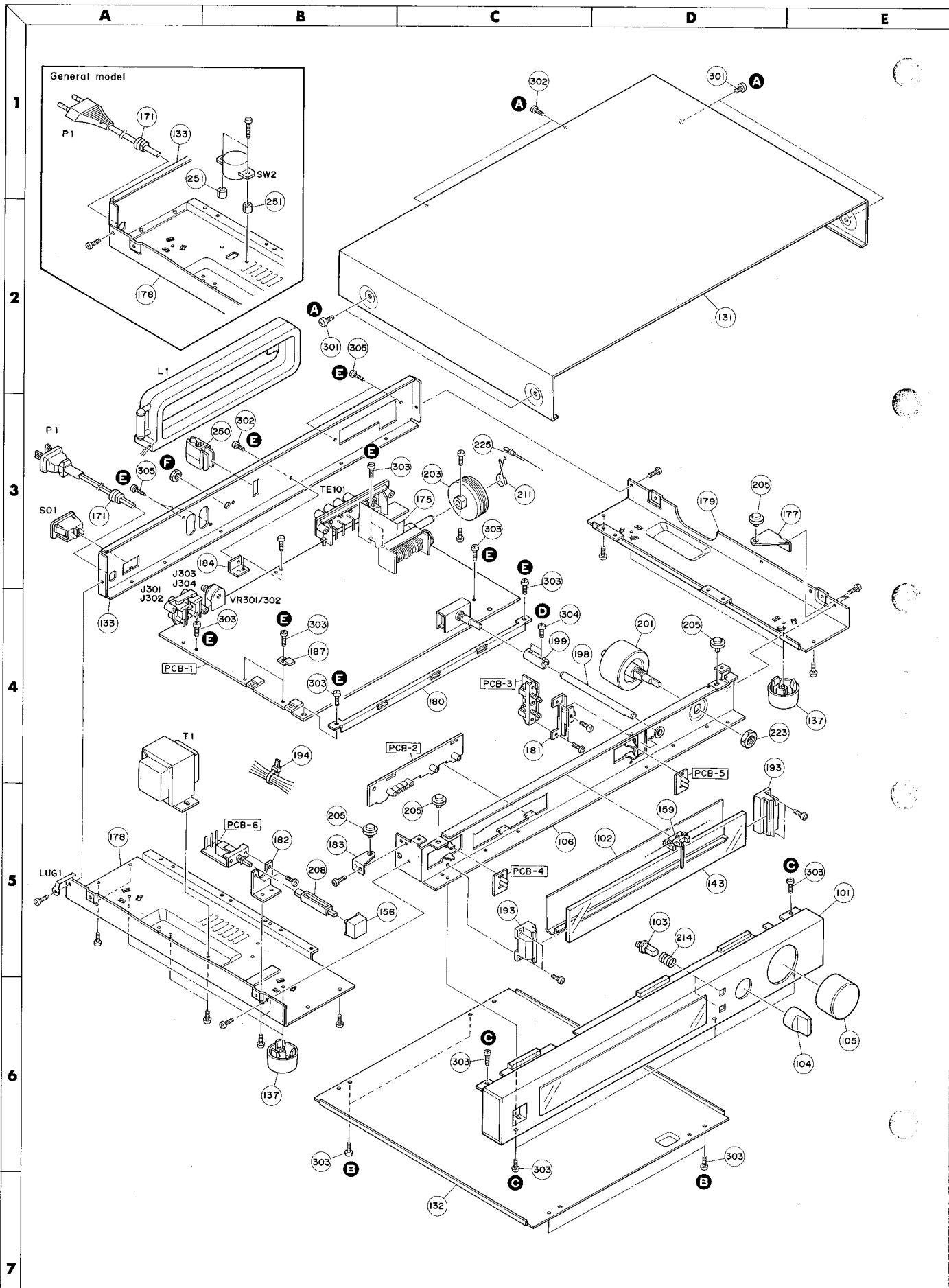

GENERAL UNIT PARTS LIST

Ref. No.	Part No.	Description
101	A443-TU910A	Front Panel Assembly
102	A554-TU910A	Dial Back Plate Assembly
103	A662-TU910A	Push Button Assembly, Muting, High Blend
104	A630-TU910A	Knob Assembly, Function
105	A630-TU910B	Knob Assembly, Tuning
106	B211-TU910A	Chassis Assembly
131	1414-02201	Cabinet Top
132	1424-13801	Cabinet Bottom
133	1424-12701	Cabinet Back (for U.S.A. & Canada models)
"	1424-13001	Cabinet Back (for General model)
137	1319-0139	Foot
143	1541-04401	Dial Panel
156	1660-00401	Push Button, Power
159	1670-00201	Dial Pointer
171	2114-415027	Bushing, Power Cord
175	2216-7147	Shield Plate
177	2219-7806	Bracket
178	2219-7981	Bracket (for U.S.A. & Canada models)
"	2219-8000	Bracket (for General model)
179	2219-7982	Bracket
180	2219-7783	Bracket
181	2219-7983	Bracket
182	2219-7984	Bracket
183	2219-7986	Bracket
184	2219-7992	Bracket
187	2222-7169	Heat Sink
193	2240-7222	Holder
194	2240-7120	Holder
198	2601-7129	Shaft
199	2601-7069	Shaft
201	2602-007118	Tuning Shaft
203	2611-7154	Dial Drum
205	2612-7001	Pulley
208	2672-7018	Lever
211	2651-0000111	Spring
214	2651-210189	Spring
223	2447-10227	Hexagon Nut
225	2424-20351	Eyelet
250	2240-7218	Holder, Antenna
251	2132-7116	Spacer
301	2347-400647	Self-Tapping Screw (+)(4 x 6 mm)
302	2347-300647	Self-Tapping Screw (+)(3 x 6 mm)
303	2347-300627	Self-Tapping Screw (+)(3 x 6 mm)
304	2322-300629	Screw (+)(3 x 6 mm)
305	2347-301041	Self-Tapping Screw (+)(3 x 10 mm)
	1111-J30167	Owner Guide (for U.S.A. model)
	1111-J30168	Owner Guide (for Canada & General models)
	1222-7224	Packing Cushion
	1221-777147	Packing Box

ELECTRICAL PARTS LIST

Ref. No.	Part No.	Description
CHASSIS MISCELLANEOUS		
△ P1	4161-71147	Power Cord (for U.S.A. & Canada models)
△ "	4161-7256	Power Cord (for General model)
△ "	4161-02100	Power Cord (for General model Australia version)
△ T1	5584-701477	Power Transformer (for U.S.A. & Canada models)
△ "	5584-701478	Power Transformer (for General model)
△ SW2	4411-104736	Rotary Switch, Voltage Selector (General model only)
△ SO1	4474-164	AC Socket, Unswitched (U.S.A. & Canada models only)
△ CO1	4443-712	Connector, Power Cord (General model only)
△ R25	5135-335J50P	Resistor, 3.3M Ω , 1/2W, Carbon (U.S.A. & Canada models only)
L1	5911-244	AM Loop Antenna
LUG1	4211-5005	Lug Terminal (U.S.A. & Canada models only)
	1397-6	Dipole Antenna (Accessory)
	4161-71184	Connection Wire (Accessory)
PCB-1 MAIN P.C. BOARD		
RESISTORS		
△ R7, 8	5102-2R2579	2.2 Ω , \pm 5%, 1/4W, Fuse
△ R13, 14, 20	5102-1004713	10 Ω , \pm 2%, 1/4W, Fuse
△ R15	5102-2204713	22 Ω , \pm 2%, 1/4W, Fuse
R157	5174-163381	16k Ω , \pm 1%, 1/4W, Metal
CONTROLS		
VR151	5101-4727173	4.7k Ω B
VR152, 202, 351, 352	5101-50371920	50k Ω B
VR201	5101-20371920	20k Ω B
VR301/302	5113-50271151	5k Ω B, Output Level
VR303	5101-30271920	3k Ω B
VR304	5101-20271920	2k Ω B
VR501	5101-50271920	5k Ω B
CAPACITORS		
C3, 4	5345-228D041	2200 μ F, \pm 20%, 25V, Electrolytic
C5, 6, 515	5345-337C041	330 μ F, \pm 20%, 16V, Electrolytic
C7, 8	5345-108C041	1000 μ F, \pm 20%, 16V, Electrolytic
C9	5345-476-25	47 μ F, \pm 20%, 25V, Electrolytic
C13	5345-107C041	100 μ F, \pm 20%, 16V, Electrolytic
C14, 15	5345-106C041	10 μ F, \pm 20%, 16V, Electrolytic
C151, 504	5345-226C0952	22 μ F, \pm 20%, 16V, Electrolytic
C152, 319, 320	5359-4725851	4700pF, \pm 5%, 100V, Polypropylene
C153	5359-6815851	680pF, \pm 5%, 100V, Polypropylene
C154, 265, 272, 508	5345-227-16	220 μ F, \pm 20%, 16V, Electrolytic
C155	5345-475D0952	4.7 μ F, \pm 20%, 25V, Electrolytic
C156	5345-225F0952	2.2 μ F, \pm 20%, 50V, Electrolytic
C158	5345-105F0952	1 μ F, \pm 20%, 50V, Electrolytic
C159, 160, 214, 502	5359-1015851	100pF, \pm 5%, 100V, Polypropylene
C161, 164, 166	5359-4715851	470pF, \pm 5%, 100V, Polypropylene
C162, 167	5359-2215851	220pF, \pm 5%, 100V, Polypropylene
C163	5359-1515851	150pF, \pm 5%, 100V, Polypropylene
C165	5359-1215851	120pF, \pm 5%, 100V, Polypropylene
C168, 169, 309, 310	5345-336C0951	33 μ F, \pm 20%, 16V, Electrolytic
C170	5359-8215851	820pF, \pm 5%, 100V, Polypropylene
C215	5345-105F0951	1 μ F, \pm 20%, 50V, Electrolytic
C216	5345-106C0951	10 μ F, \pm 20%, 16V, Electrolytic
C221, 359	5345-477C041	470 μ F, \pm 20%, 16V, Electrolytic
C257	5345-107-16	100 μ F, \pm 20%, 16V, Electrolytic
C259	5359-4315851	430pF, \pm 5%, 100V, Polypropylene
C262, 360	5345-474-50	0.47 μ F, \pm 20%, 50V, Electrolytic
C263, 267, 361, 362, 363	5345-335-25	3.3 μ F, \pm 20%, 25V, Electrolytic
C266	5345-154F0951	0.15 μ F, \pm 20%, 50V, Electrolytic
C301, 302, 323, 324, 501, 503	5359-1025851	1000pF, \pm 5%, 100V, Polypropylene
C303, 304, 307, 308	5359-1525851	1500pF, \pm 5%, 100V, Polypropylene
C305, 306, 516	5359-3025851	3000pF, \pm 5%, 100V, Polypropylene

Ref. No.	Part No.	Description
C313, 314	5345-224F0951	0.22 μ F, \pm 20%, 50V, Electrolytic
C315, 316	5345-106D0951	10 μ F, \pm 20%, 25V, Electrolytic
C317, 318	5359-1535851	0.015 μ F, \pm 5%, 100V, Polypropylene
C321, 322	5359-3925851	3900pF, \pm 5%, 100V, Polypropylene
C327	5359-6825851	6800pF, \pm 5%, 100V, Polypropylene
C351, 357	5345-476-16	47 μ F, \pm 20%, 16V, Electrolytic
C352	5345-104F0951	0.1 μ F, \pm 20%, 50V, Electrolytic
C353	5345-225-50	2.2 μ F, \pm 20%, 50V, Electrolytic
C355	5345-224F0952	0.22 μ F, \pm 20%, 50V, Electrolytic
C358	5345-106-16	10 μ F, \pm 20%, 16V, Electrolytic
VC101/102/103/251/252	5315-7112	Variable Capacitor (w/Trimmers TC101, 102, 251, 252)
TC103	5371-91	Trimmer Capacitor
INTEGRATED CIRCUIT		
IC151	5652-BA1330	BA1330
IC152	5654-TC4066BP	TC4066BP
IC153, 154	5654-TC4011BP	TC4011BP
IC155, 351	5652-M5219P	M5219P
IC201	5652-HA11225	HA11225
IC251	5652-LA1245	LA1245
IC352	5654-TC4001BP	TC4001BP
TRANSISTORS		
Q1	5611-1305(Y)	2SA1305(Y)
Q2	5613-3297(Y)	2SC3297(Y)
Q3, 151, 152, 153, 154 155, 157, 252, 303, 304, 305, 306, 309, 310, 352, 354, 356, 357, 362, 363	5613-2603(F)	2SC2603(F) or 2SC2603(E)
Q4, 5, 6, 156, 158, 307, 308, 311, 312, 315, 316, 353, 355, 358, 359	5611-1115(F)	2SA1115(F) or 2SA1115(E)
Q101	5616-2SK241(Y)	F.E.T., 2SK241(Y)
Q102	5613-535(B)	2SC535(B) or 2SC535(C)
Q103	5613-461(B)	2SC461(B) or 2SC461(C)
Q201, 202, 203, 204	5613-2058(N)	2SC2058(N) or 2SC2058(P)
Q251	5616-2SK241(Y)	F.E.T., 2SK241(Y) or 2SK241(GR1)
Q301, 302, 323, 351	5616-2SK381(D)	F.E.T., 2SK381(D)
Q313, 314	5615-2SJ103(GR)	F.E.T., 2SJ103(GR)
Q317, 318	5615-74(BL)	F.E.T., 2SJ74(BL)
Q319, 320	5613-2878(B)	2SC2878(B)
Q360, 361	5614-468(C)	2SD468(C) or 2SD468(D)
DIODES		
Δ D1	5685-1F	Bridge Silicon, SIRBA10
Δ D2, 7	5636-1S2471	1S2471
D3, 4	5635-HZ15-1L	Zener, HZ15-1L
D5	5635-HZ12B2L	Zener, HZ12B2L
D101	5633-1S2236	1S2236
D151, 152, 201, 301, 302, 351, 352, 353, 354, 355, 356, 357, 358, 359, 360, 361, 362, 363, 364, 365, 366, 367, 368, 369, 380, 501, 502, 503, 504	5631-1S2473	1S2473
COILS		
L101	5995-703027	Balun
L102	5943-70325	
L103	5943-70225	
L104	5991-7065	
L105	5942-00420	
L106, 201, 202	5995-2R2225	2.2 μ H
L251	5933-70129	
L252	5922-00112	

Ref. No.	Part No.	Description
TRANSFORMERS		
T101	5562-0237	
T201	5574-7024	
T251	5552-70113	
T252	5932-70123	
MISCELLANEOUS		
CF201, 202, 203	5671-7119A	Ceramic Filter (for U.S.A. & Canada models)
CF201	5671-7141A	Ceramic Filter (for General model)
CF202, 203	5671-7142A	Ceramic Filter (for General model)
CF251	5671-7139G	Ceramic Filter, SFP450G
CF252	5671-7137C	Ceramic Filter, BFU450C
SW301	4421-022110	Slide Switch, De-Emphasis (General model only)
SW351	4412-043717	Rotary Slide Switch, Function
J301/302/303/304	4484-31	4-Pin Jack, Output
TE101	4214-154	External Antenna Terminals (for U.S.A. & Canada models)
"	4215-58	External Antenna Terminals (for General model)
"	2132-5049	Spacer, R103, R107, R112, R258 (General model only)
PCB-2 LEVEL METER P.C. BOARD		
CAPACITOR		
C364	5345-106-16	10 μ F, \pm 20%, 16V, Electrolytic
INTEGRATED CIRCUIT		
IC353	5652-AN6875	AN6875
TRANSISTORS		
Q362, 363	5613-2603(F)	2SC2603(F) or 2SC2603(E)
DIODES		
D371, 372	5637-GL5HD10	L.E.D., GL5HD10, Red, Station Lock, Stereo FM
D373, 374, 375, 376, 377	5637-5NG510(C)	L.E.D., GL5NG510(C) or GL5NG510(B), Green, Signal Strength
PCB-3 MUTING & HIGH BLEND SWITCHES P.C. BOARD		
SW352, 353	4431-02047170	Push Switch, Muting, High Blend
PCB-4 and PCB-5 LAMP P.C. BOARDS		
LP1, 2	5731-1207144	Lamp, Green, 12V 100mA
LP3, 4	5731-1207167	Lamp, Orange, 12V 40mA
PCB-6 POWER SWITCH P.C. BOARD		
Δ SW1	4431-A027153	Push Swich, Power
J1	4443-030185	Connector, 3 Pos.

SCHEMATIC DIAGRAM

FM FRONT END

IF and FM DETECTOR

FM PLL MPX

FM PLL MPX

AUDIO AMP.

General model SW301 De-Emphasis

POWER SUPPLY

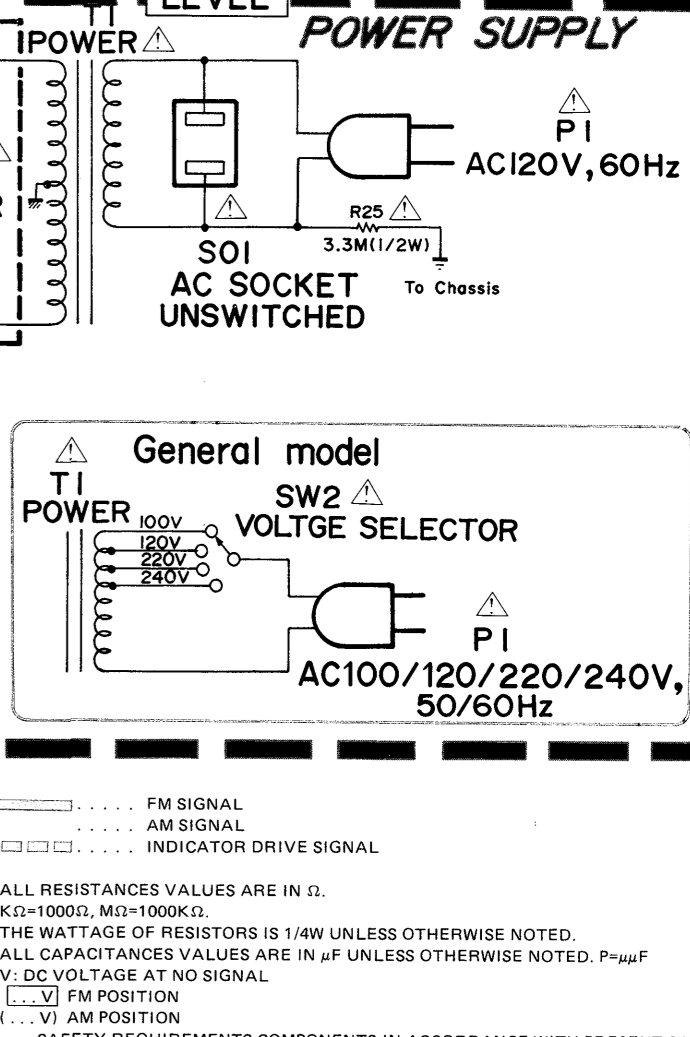
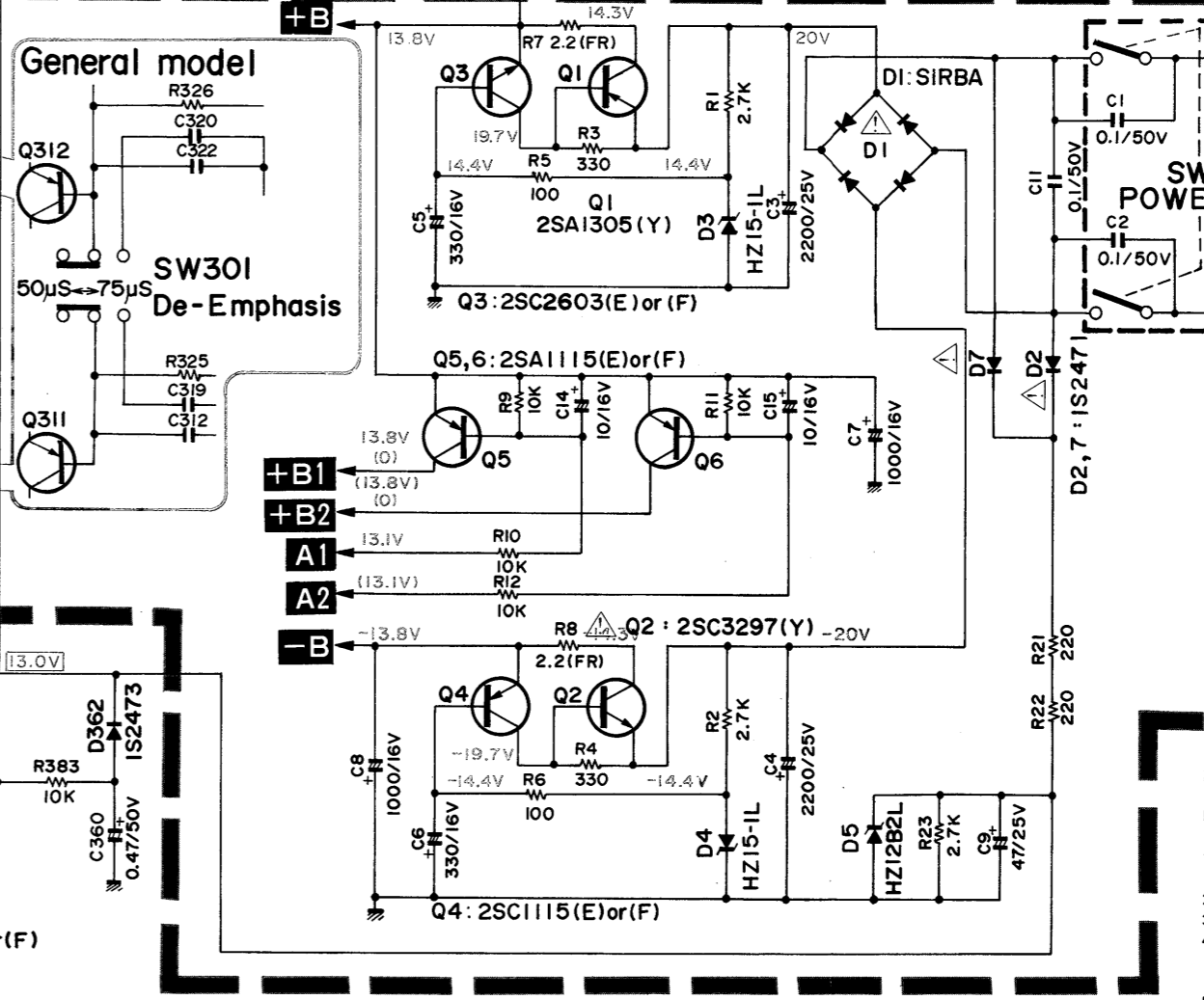
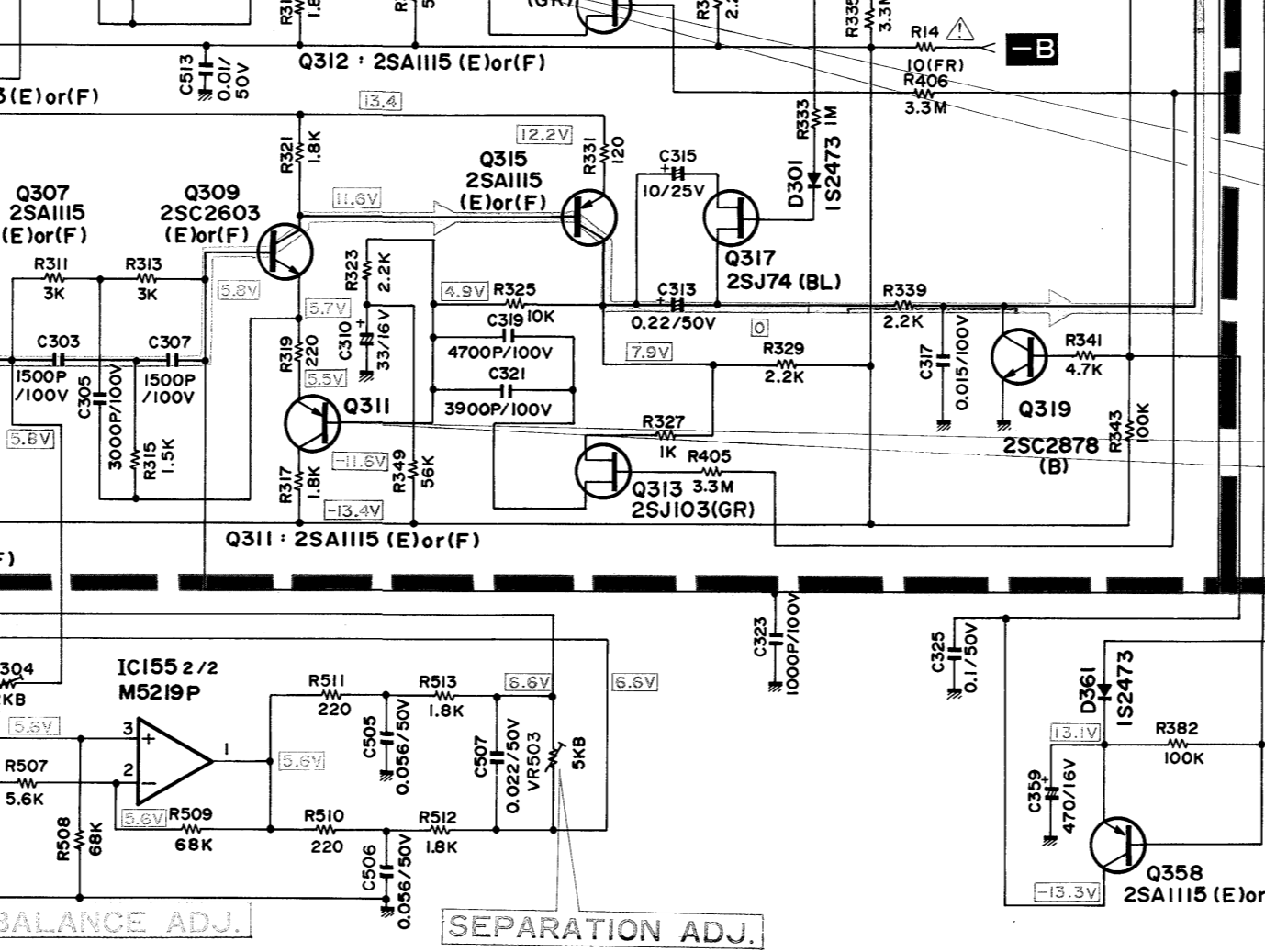
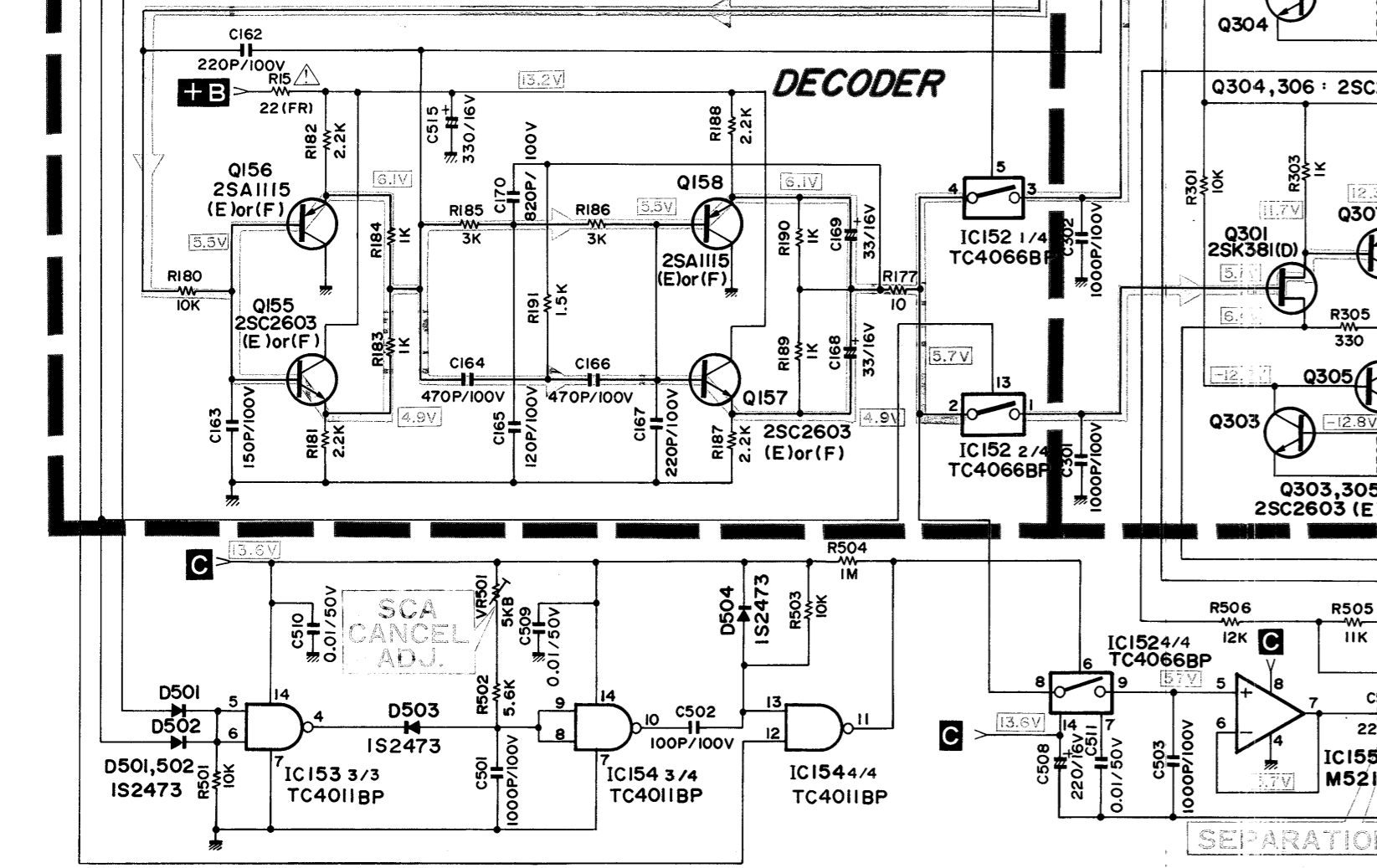
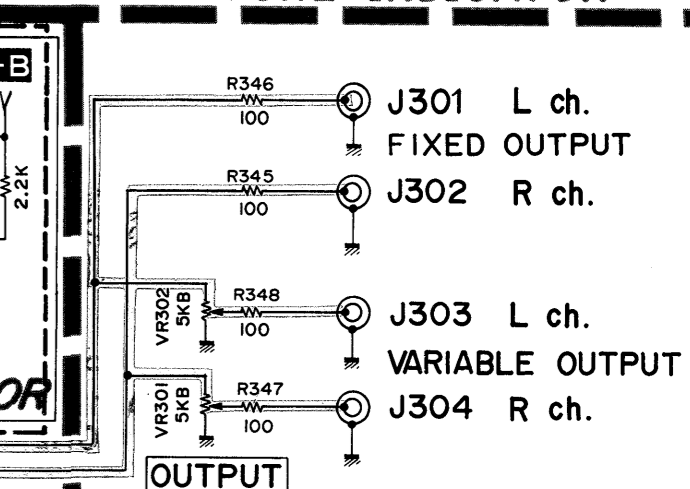
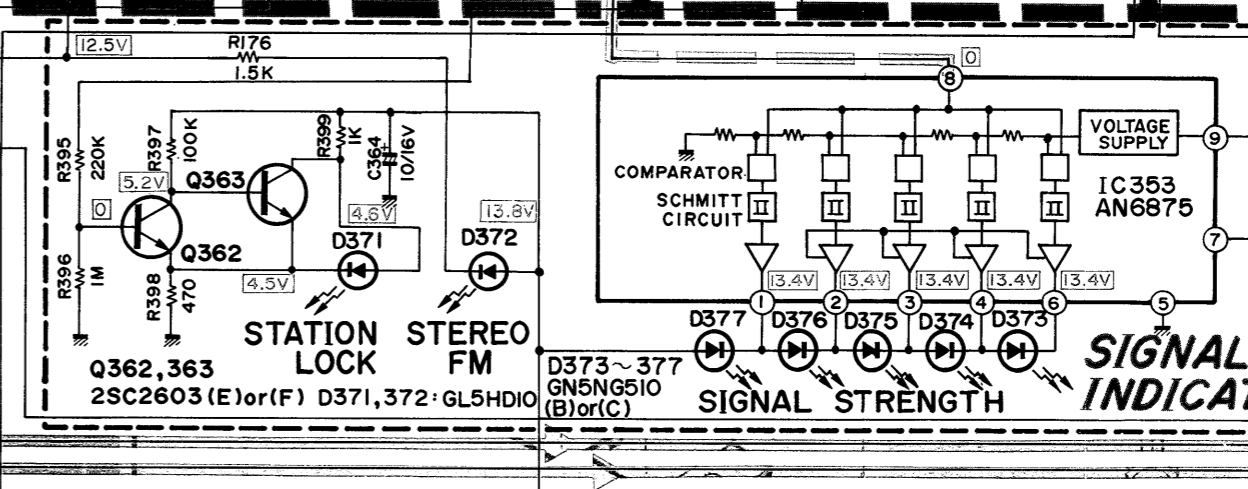
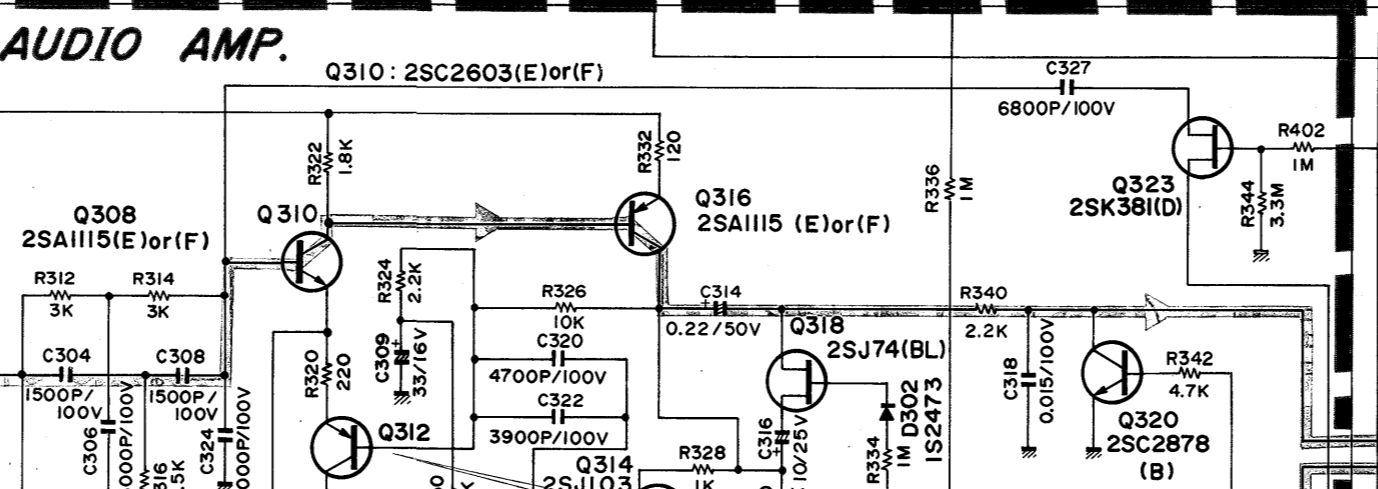
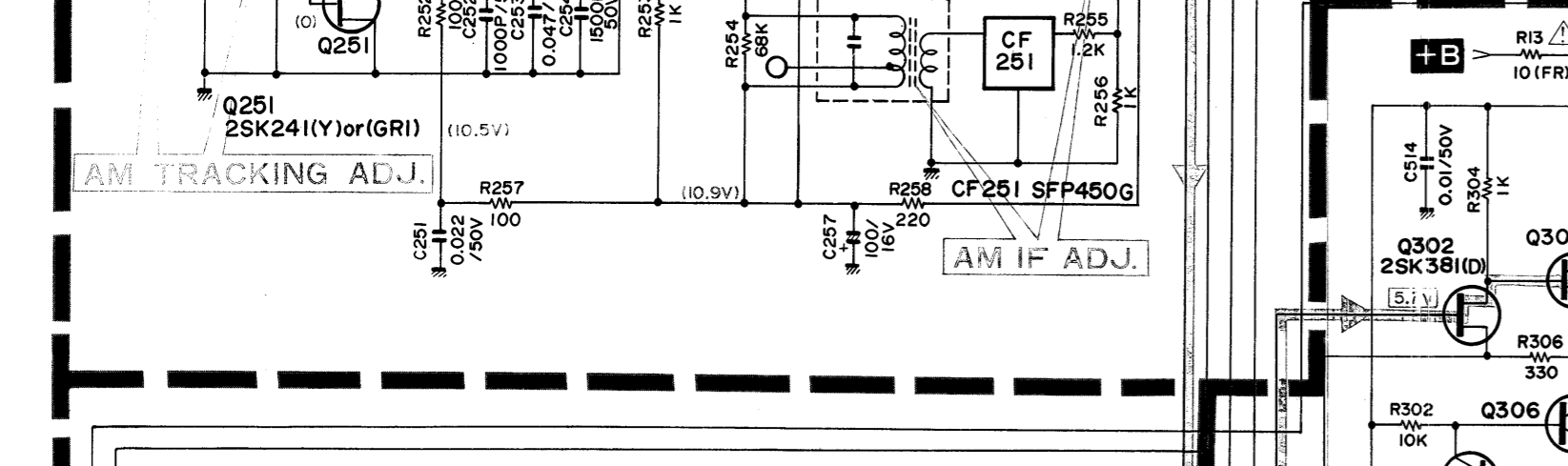
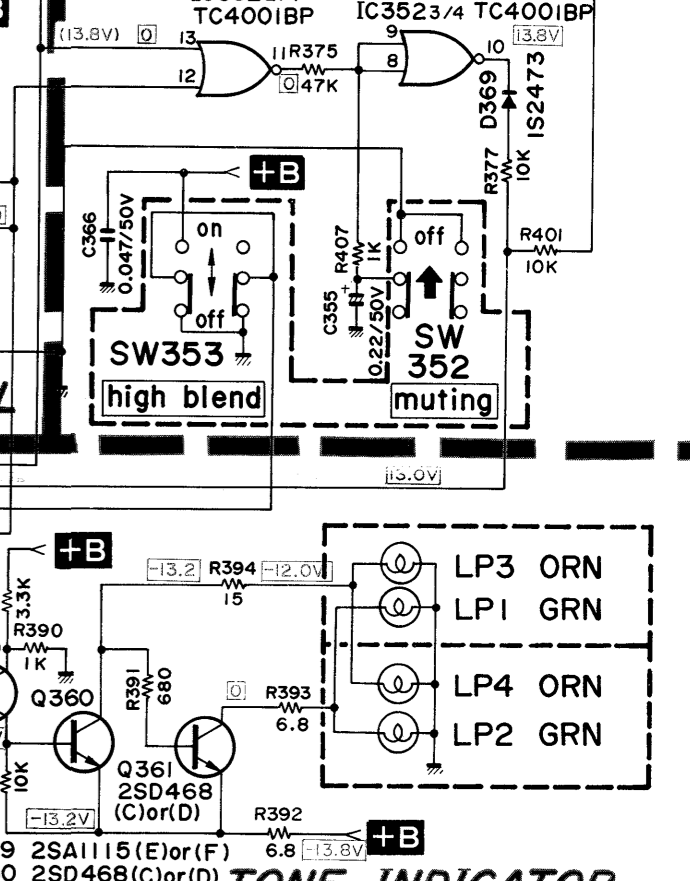
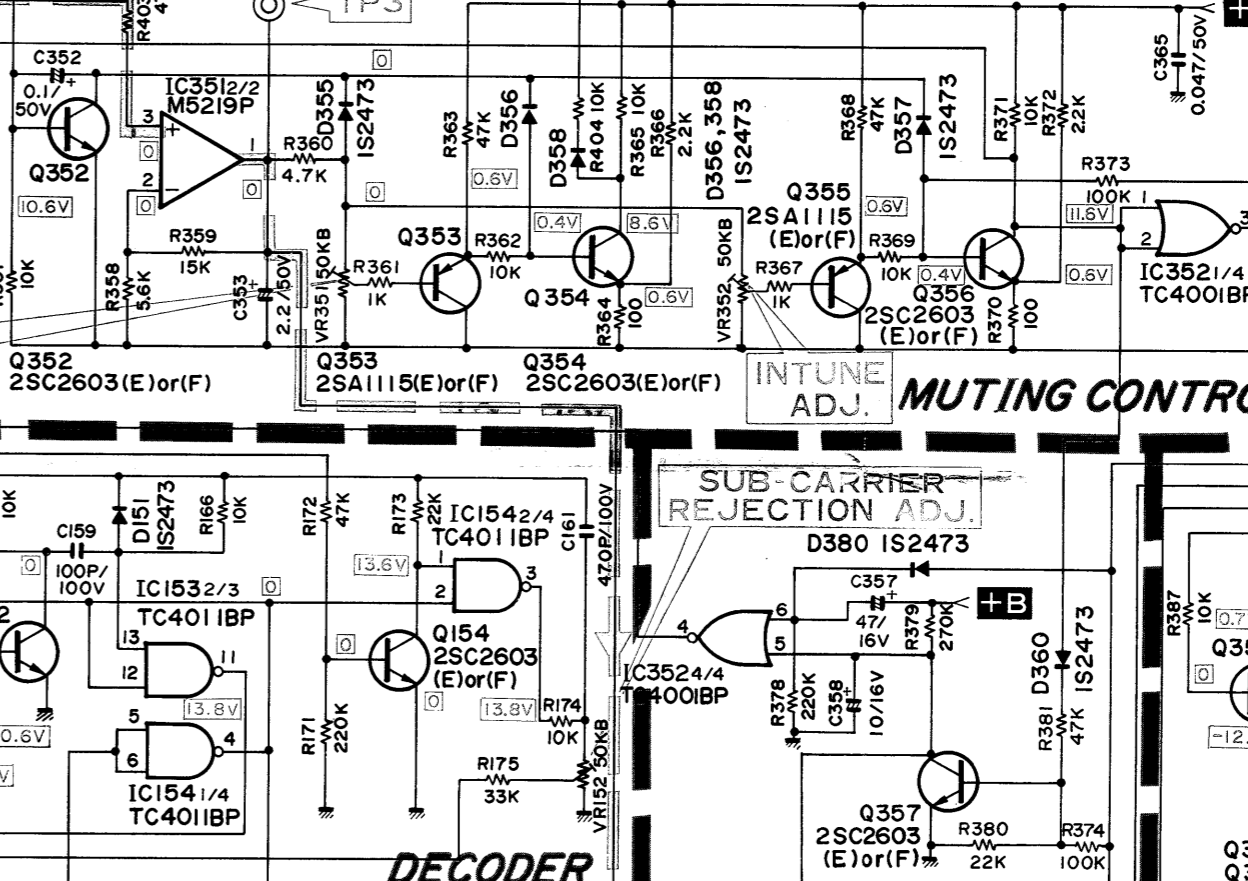
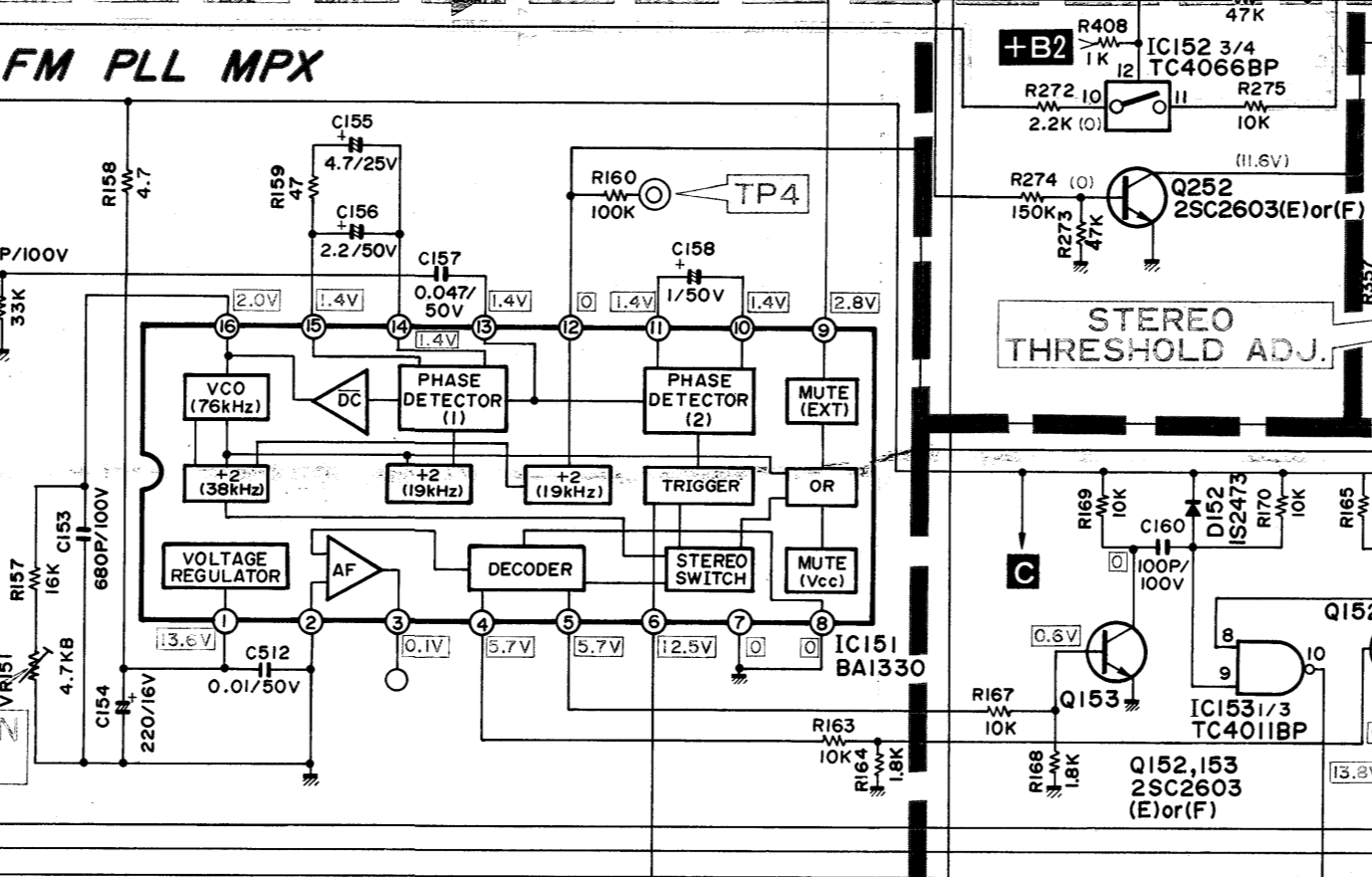
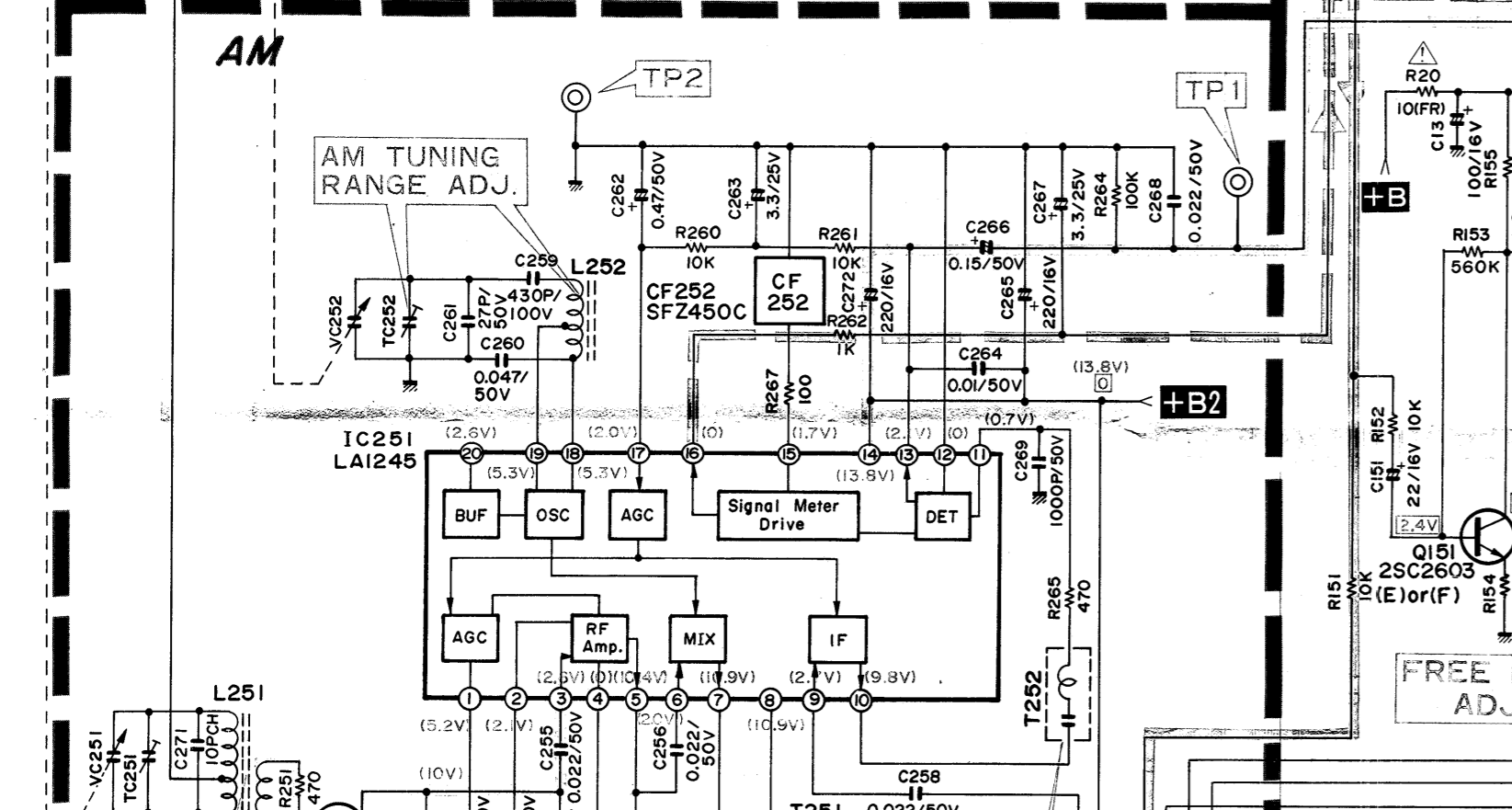
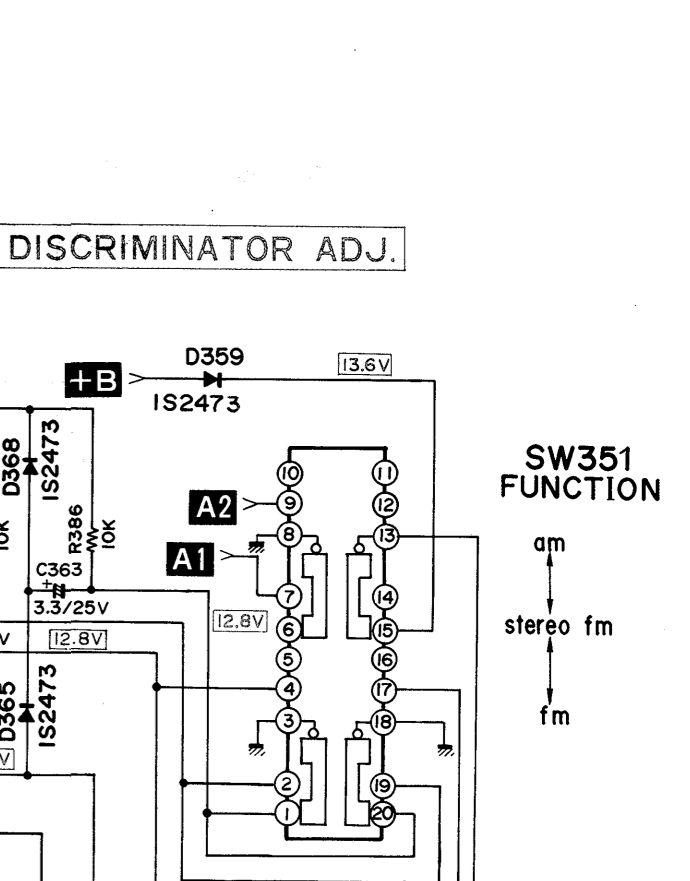
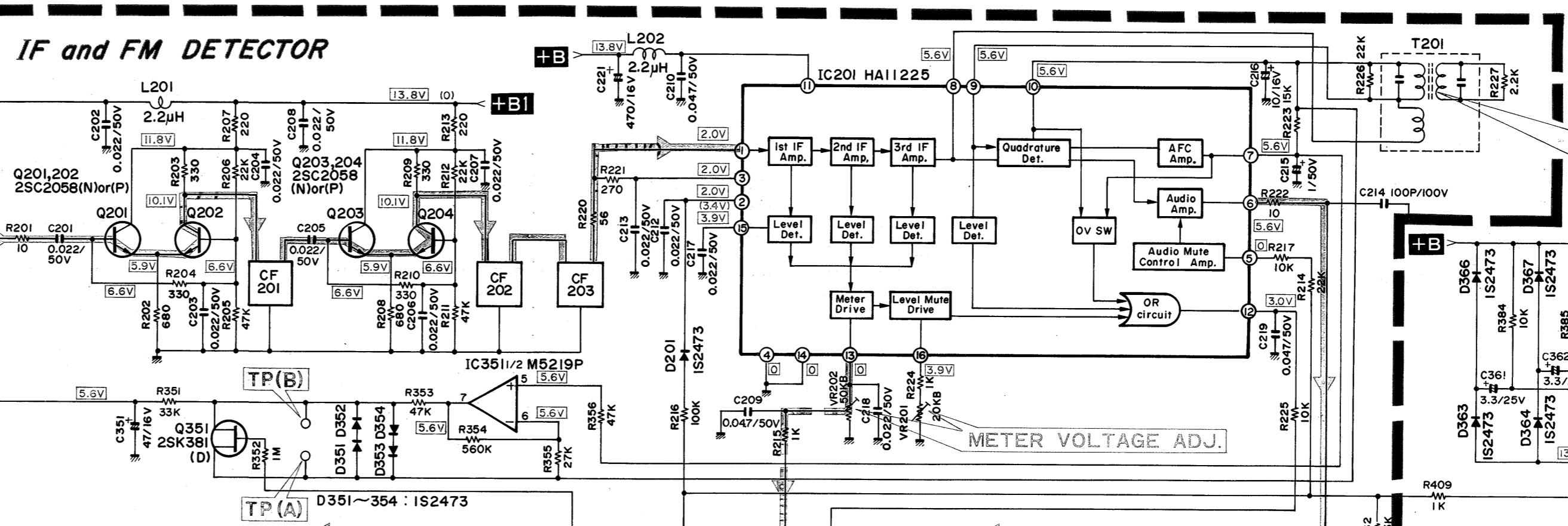
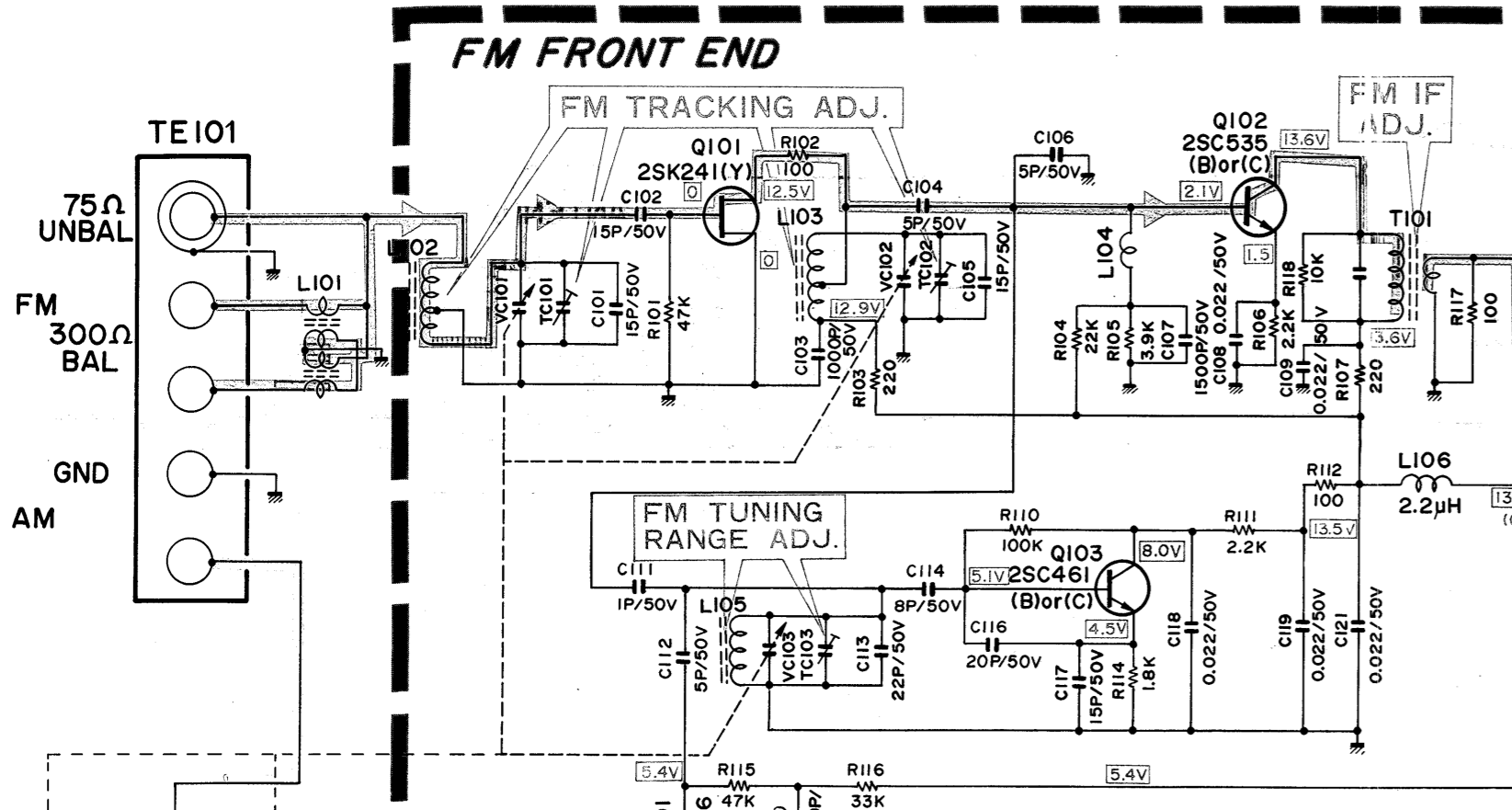

1. ALL RESISTANCE VALUES ARE IN Ω.
 2. THE WATTAGE OF RESISTORS IS 1/4W UNLESS OTHERWISE NOTED.
 3. ALL CAPACITANCE VALUES ARE IN μF UNLESS OTHERWISE NOTED. P=μF
 4. V=DC VOLTAGE AT NO SIGNAL
 5. (FM) FM POSITION
 6. (AM) AM POSITION
 7. SAFETY-REQUIREMENTS COMPONENTS IN ACCORDANCE WITH PRESENT SAFETY REGULATIONS, THESE COMPONENTS MUST ONLY BE REPLACED BY ORIGINAL PARTS.

SCHEMATIC DIAGRAM

FM FRONT END

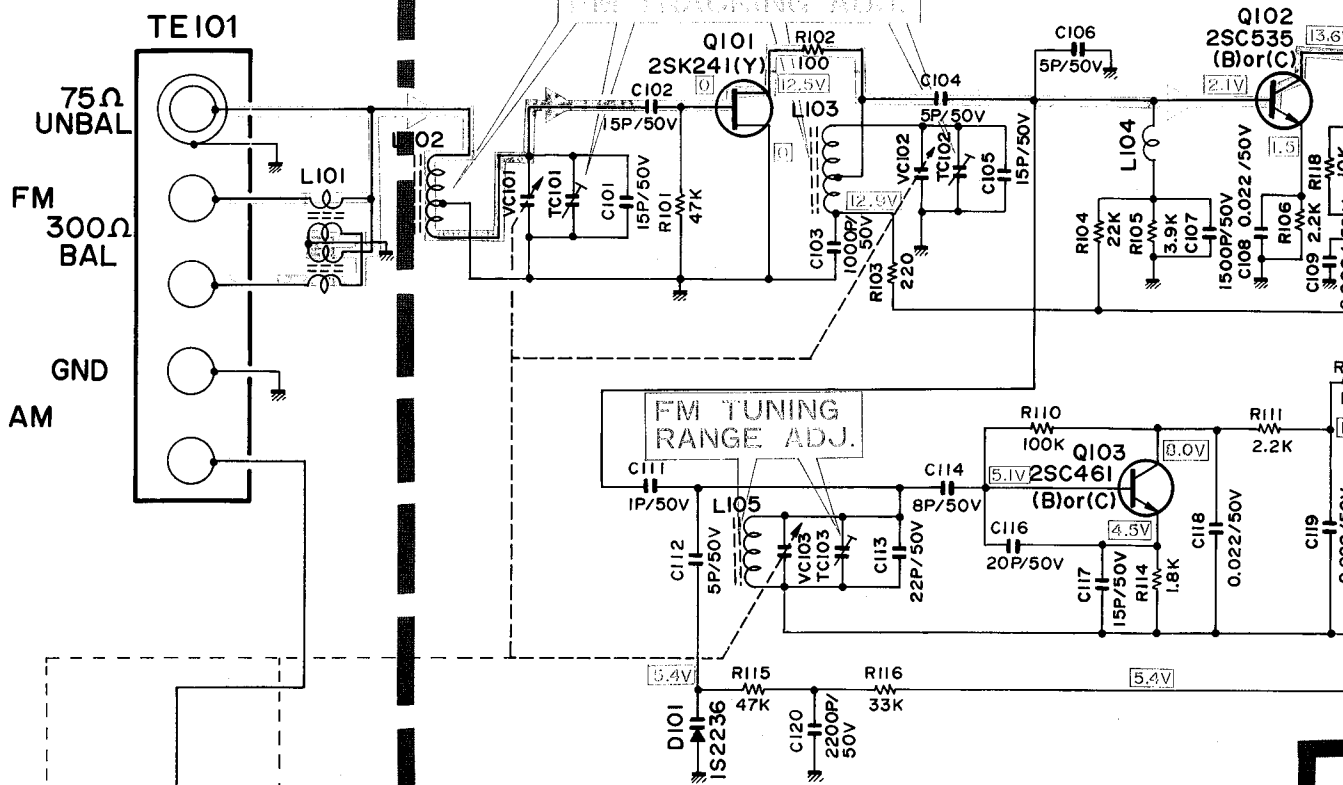

AM

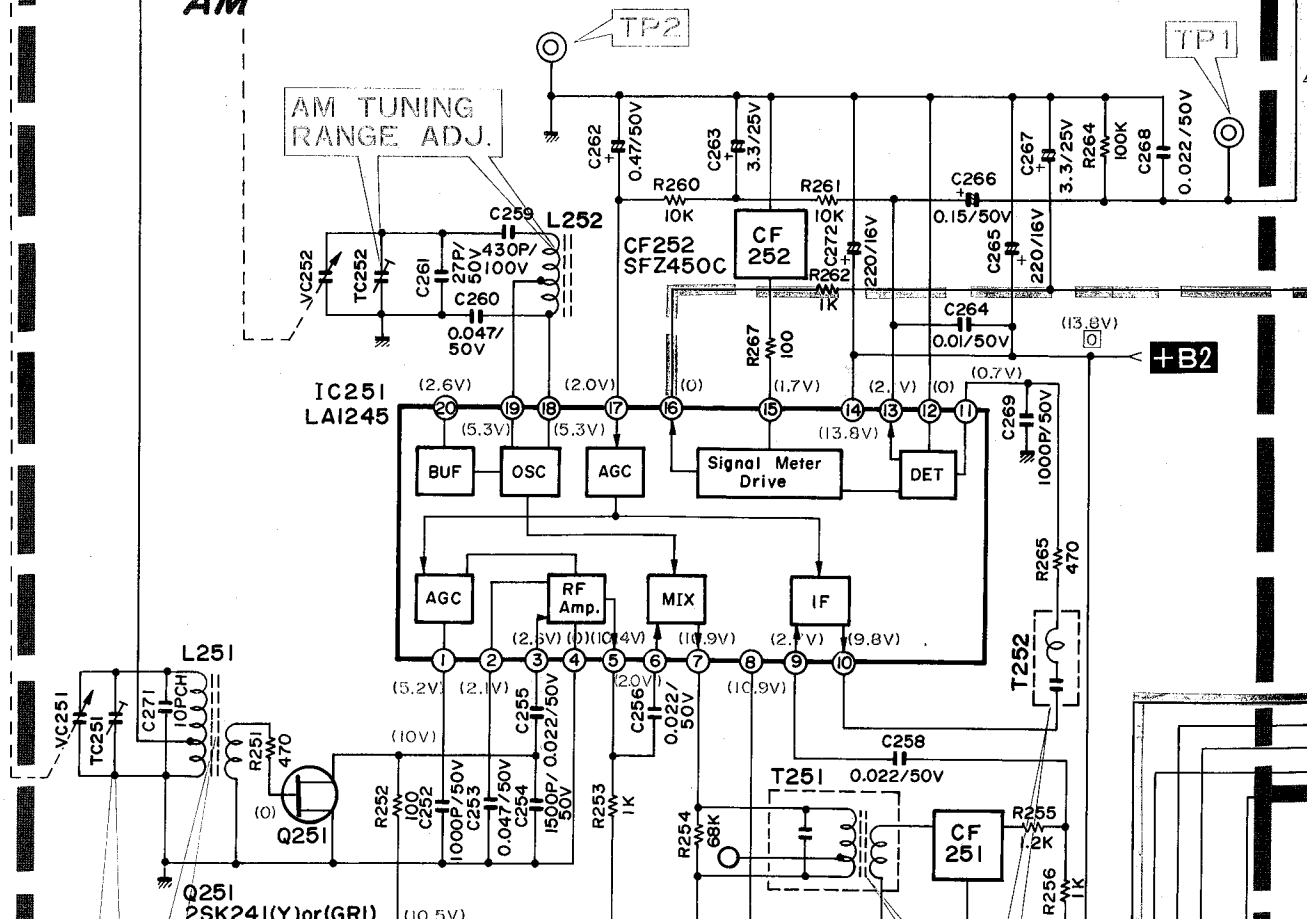

IF and FM DETECTOR

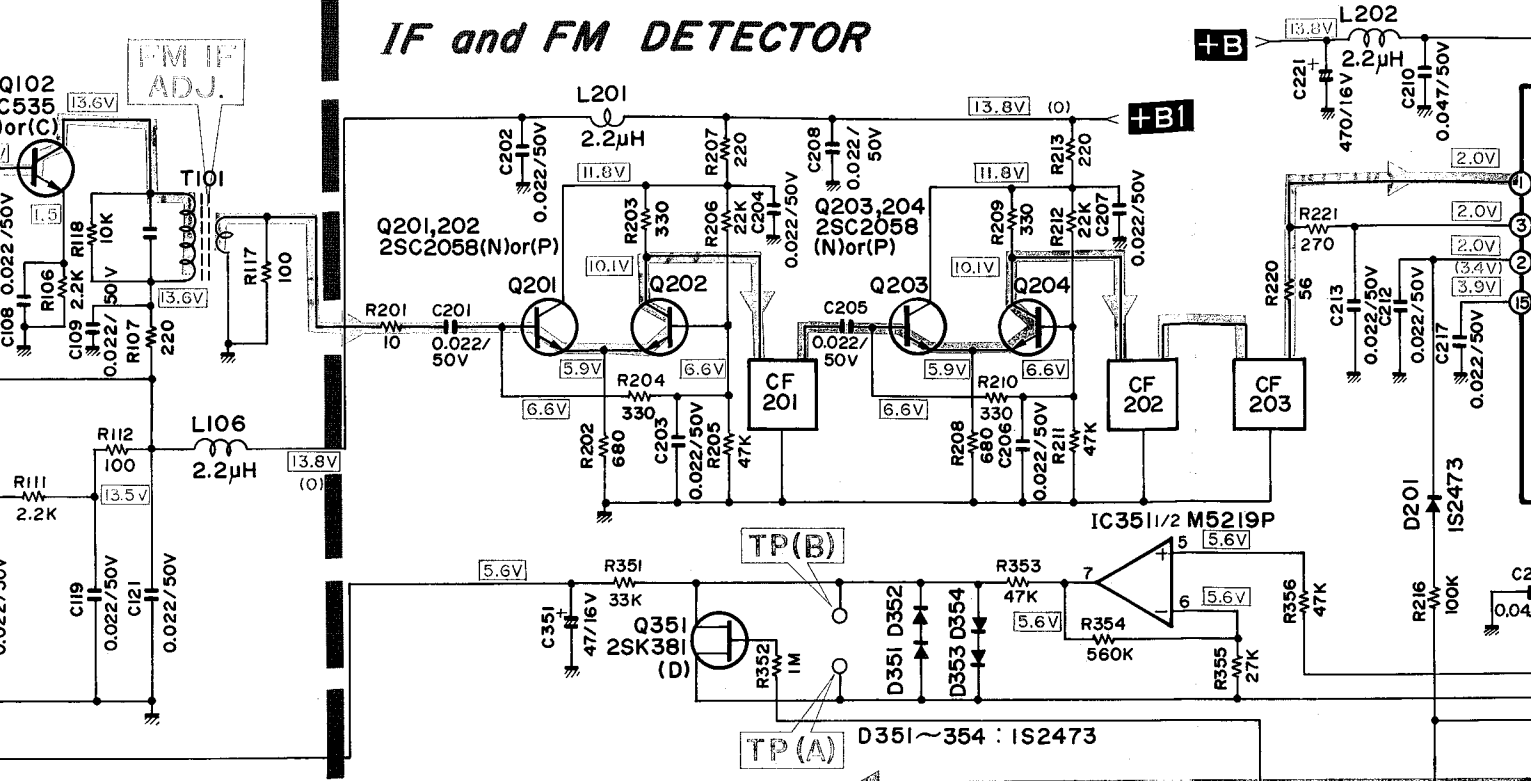

FM PLL MPX

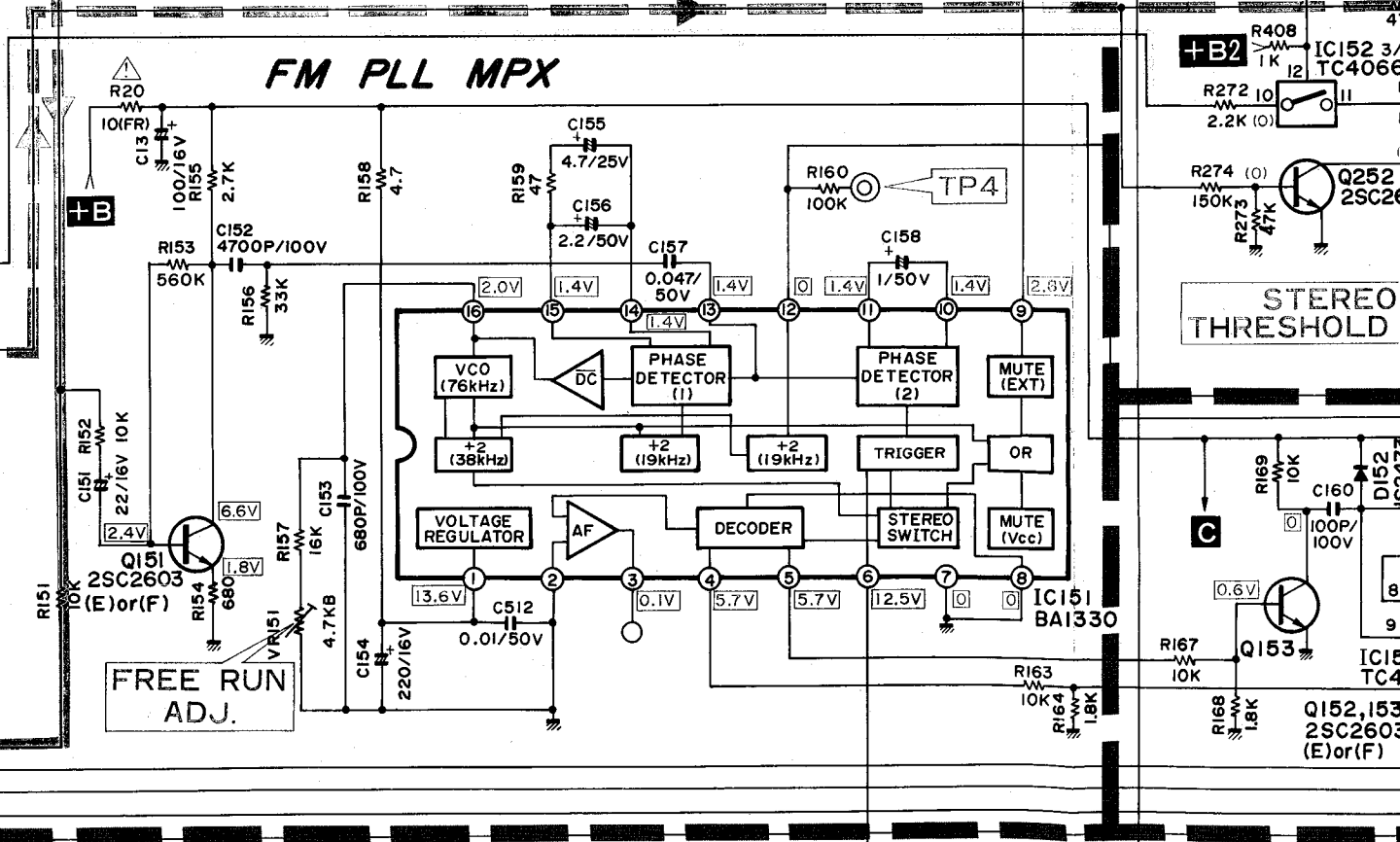

AUDIO AMP.

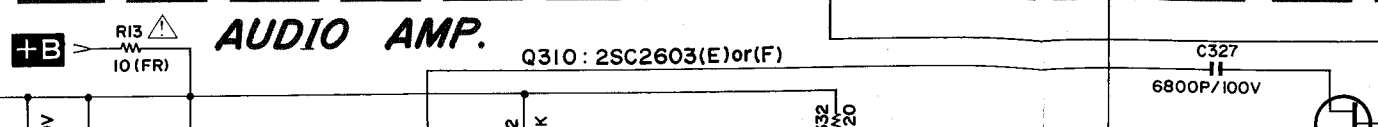

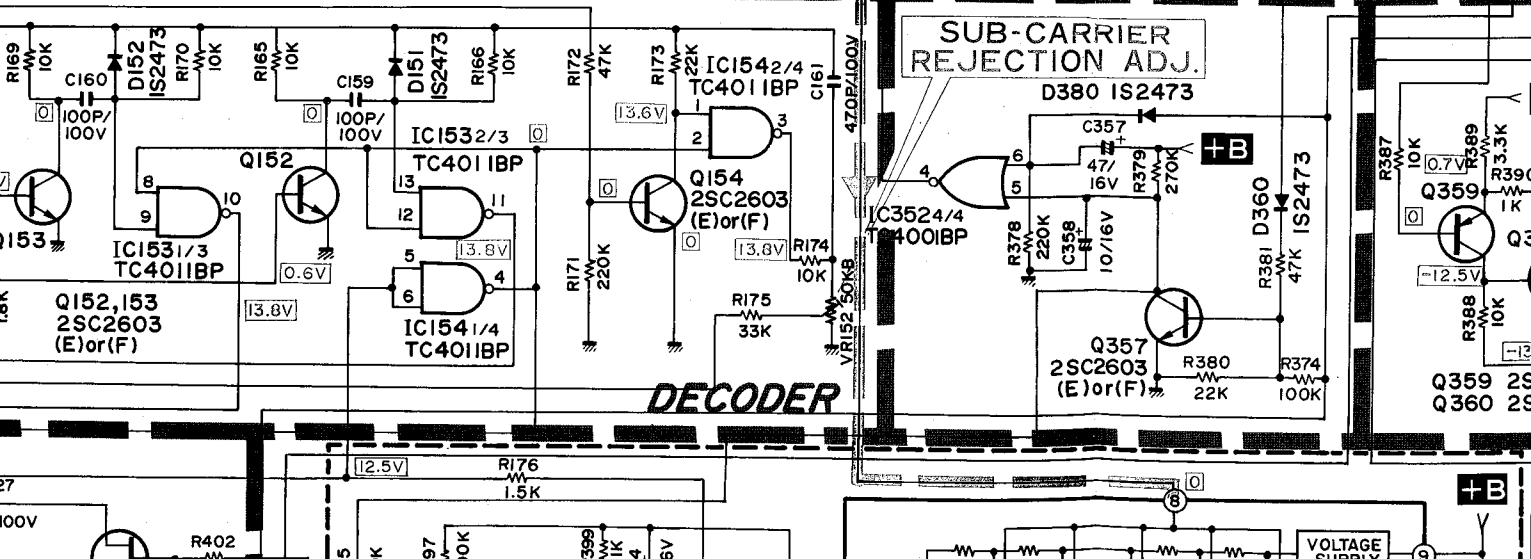
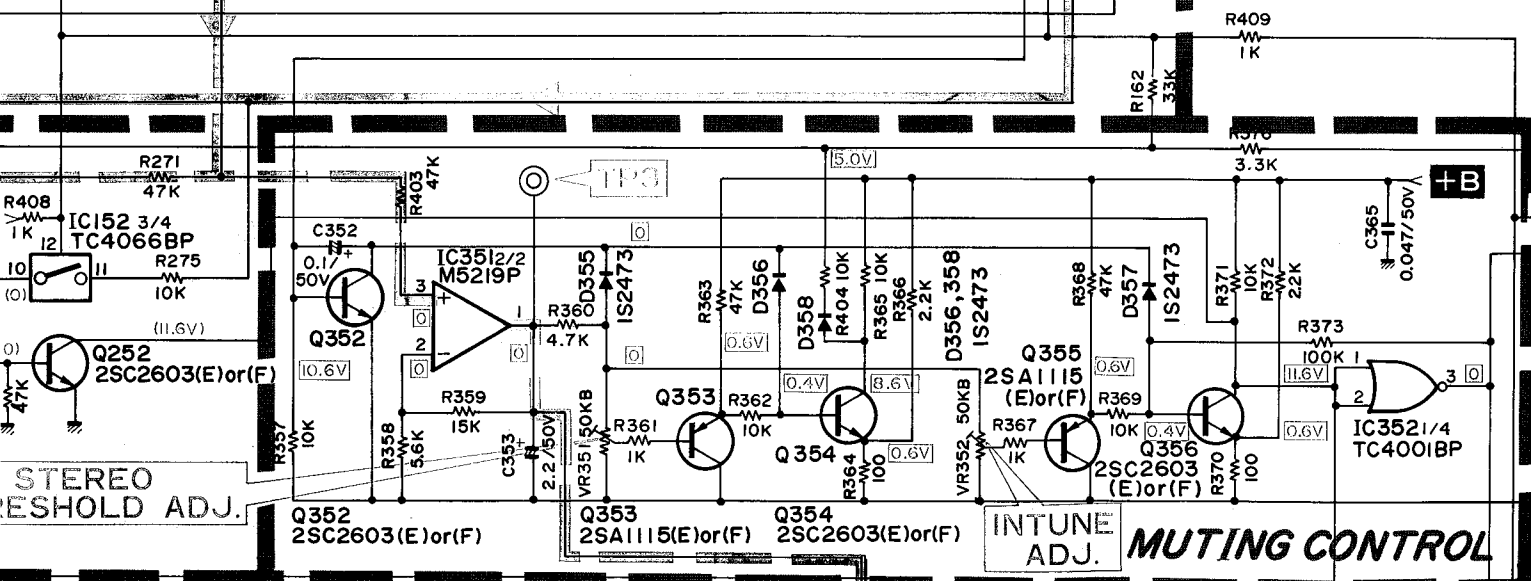
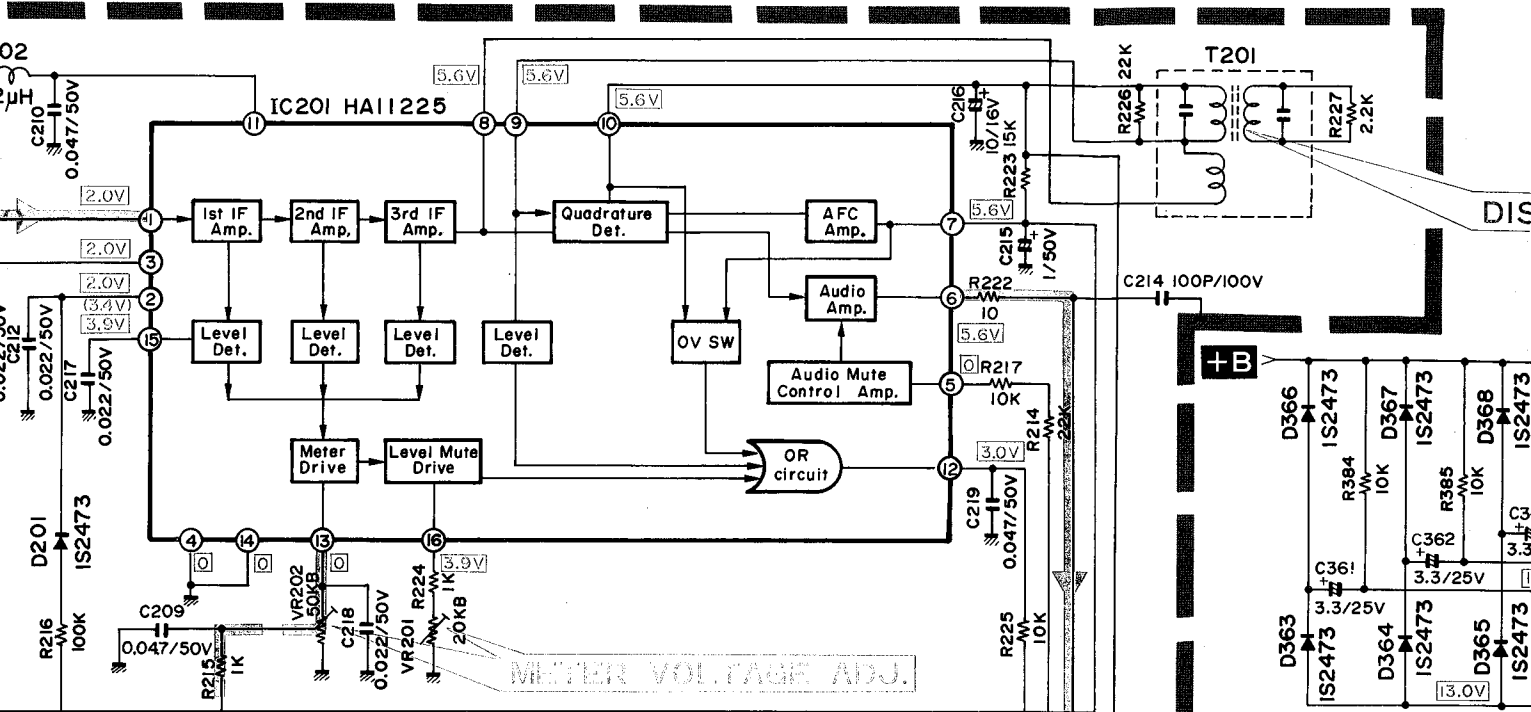

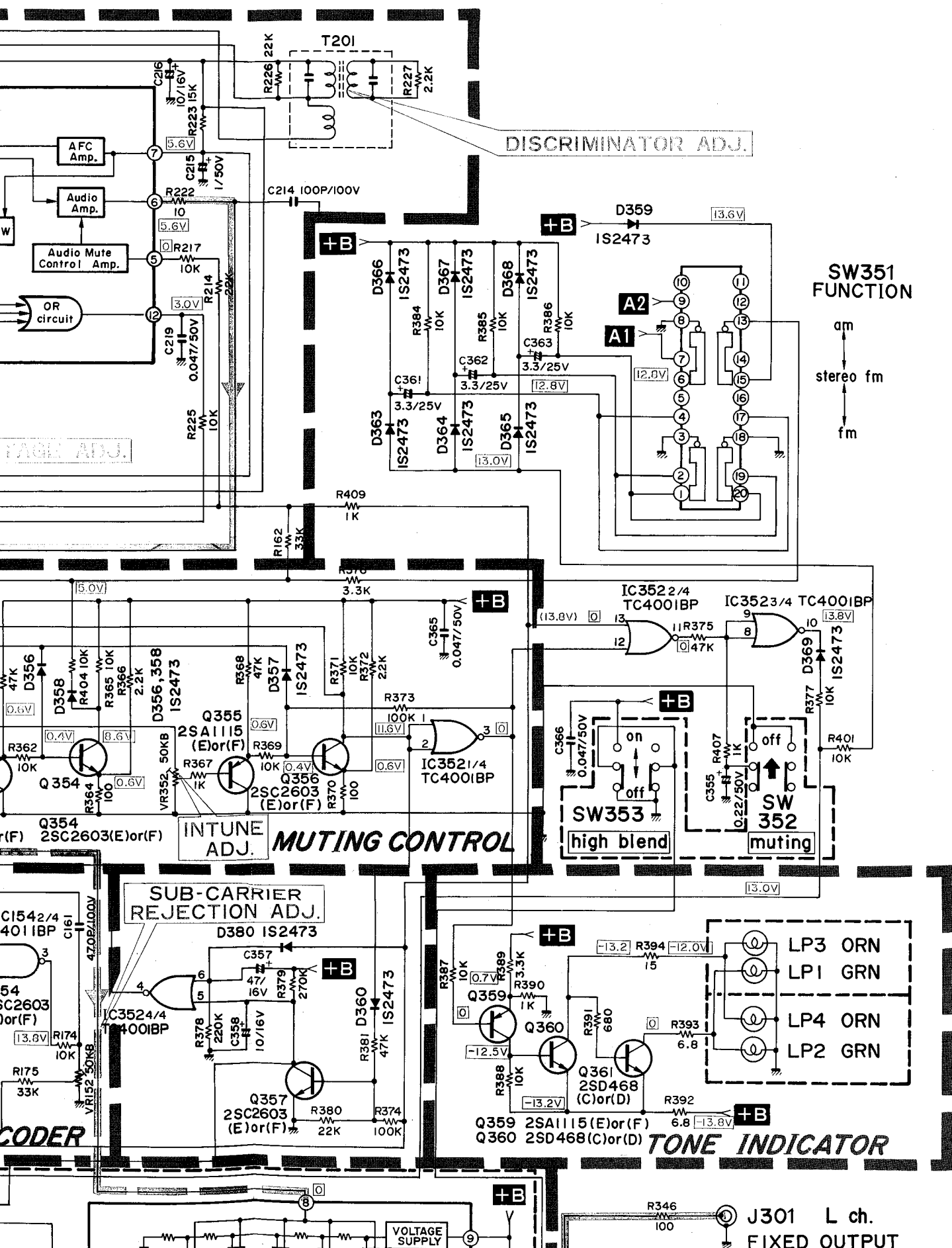

5
6
7
8
9
10

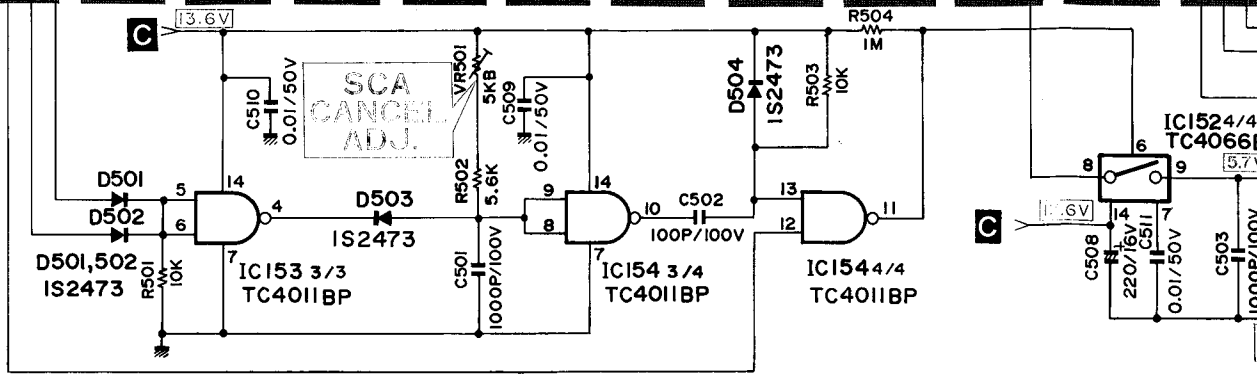
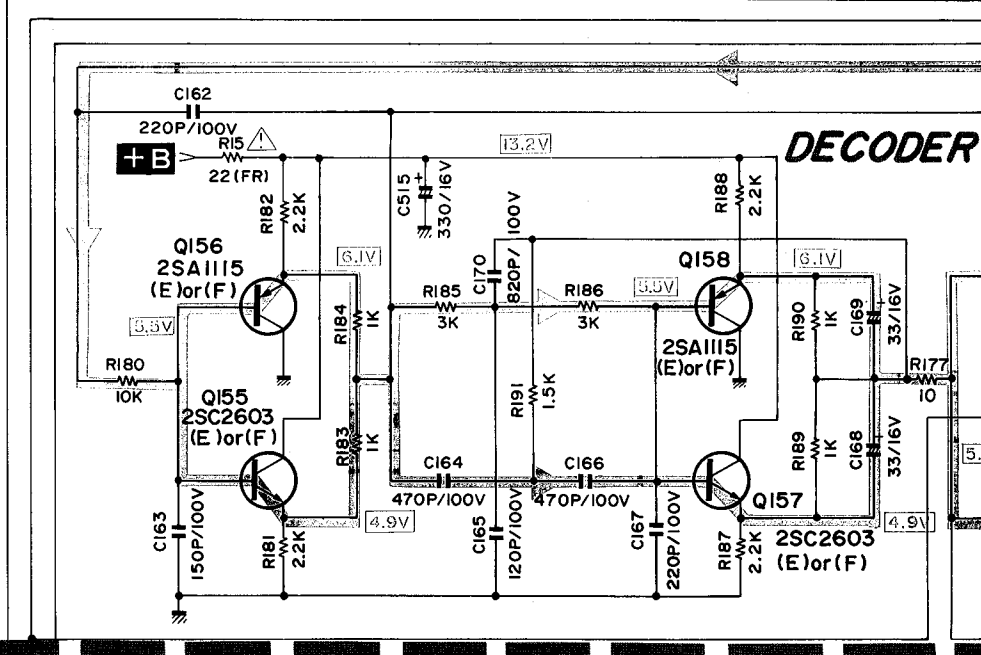
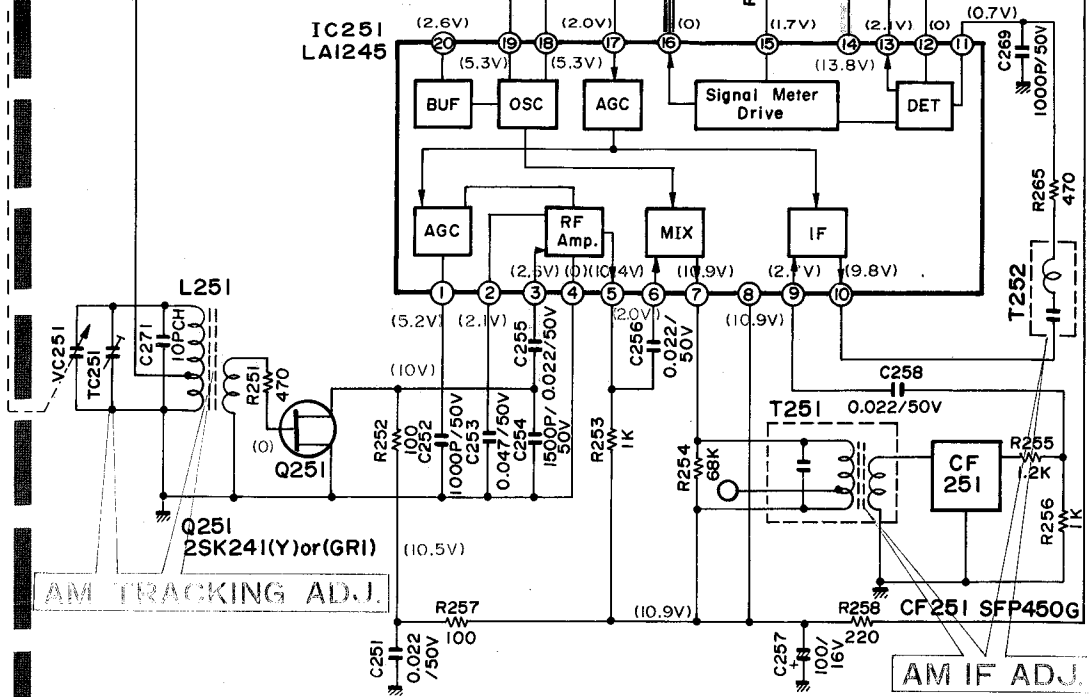

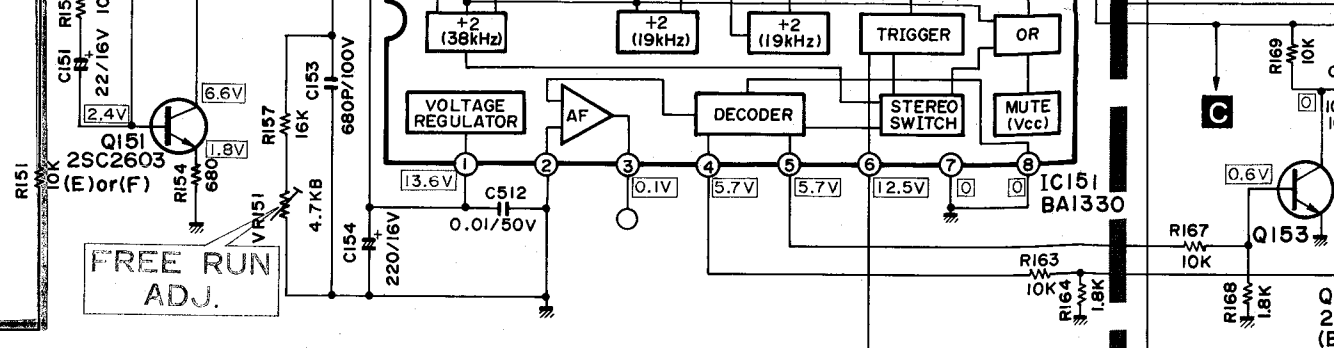

AUDIO AMP.

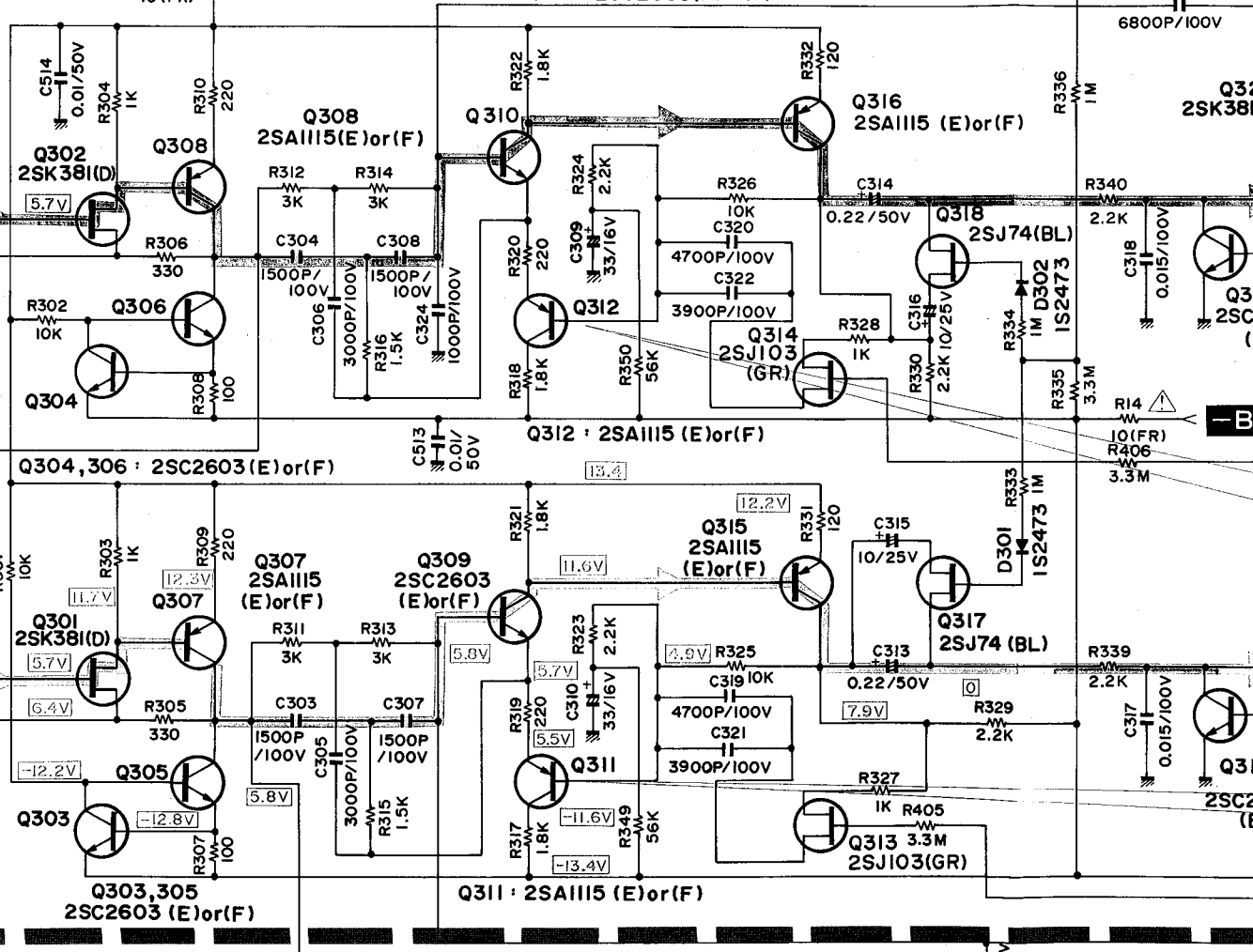

SEPARATION BALANCE ADJ.

SEPARATION ADJ.

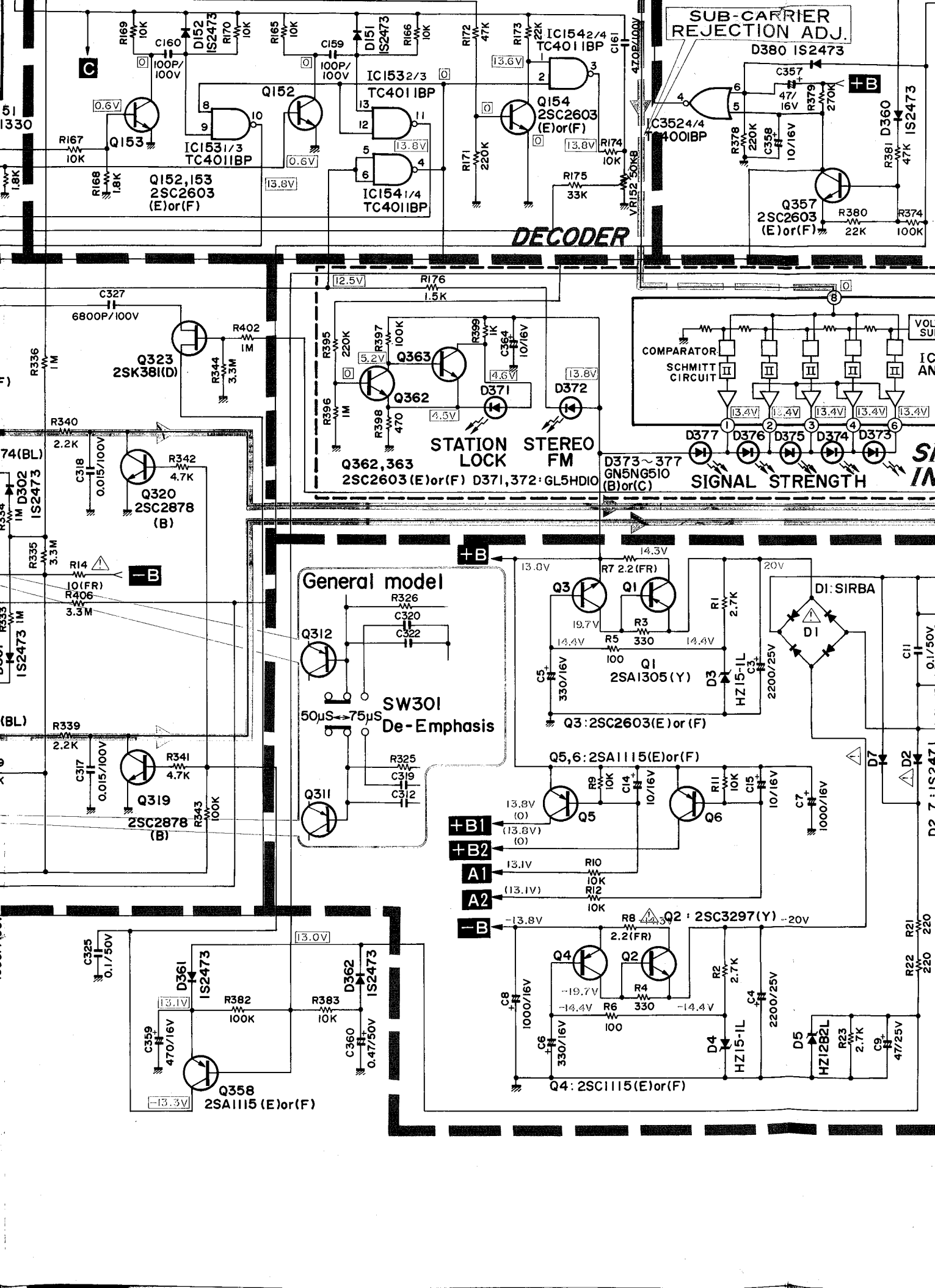

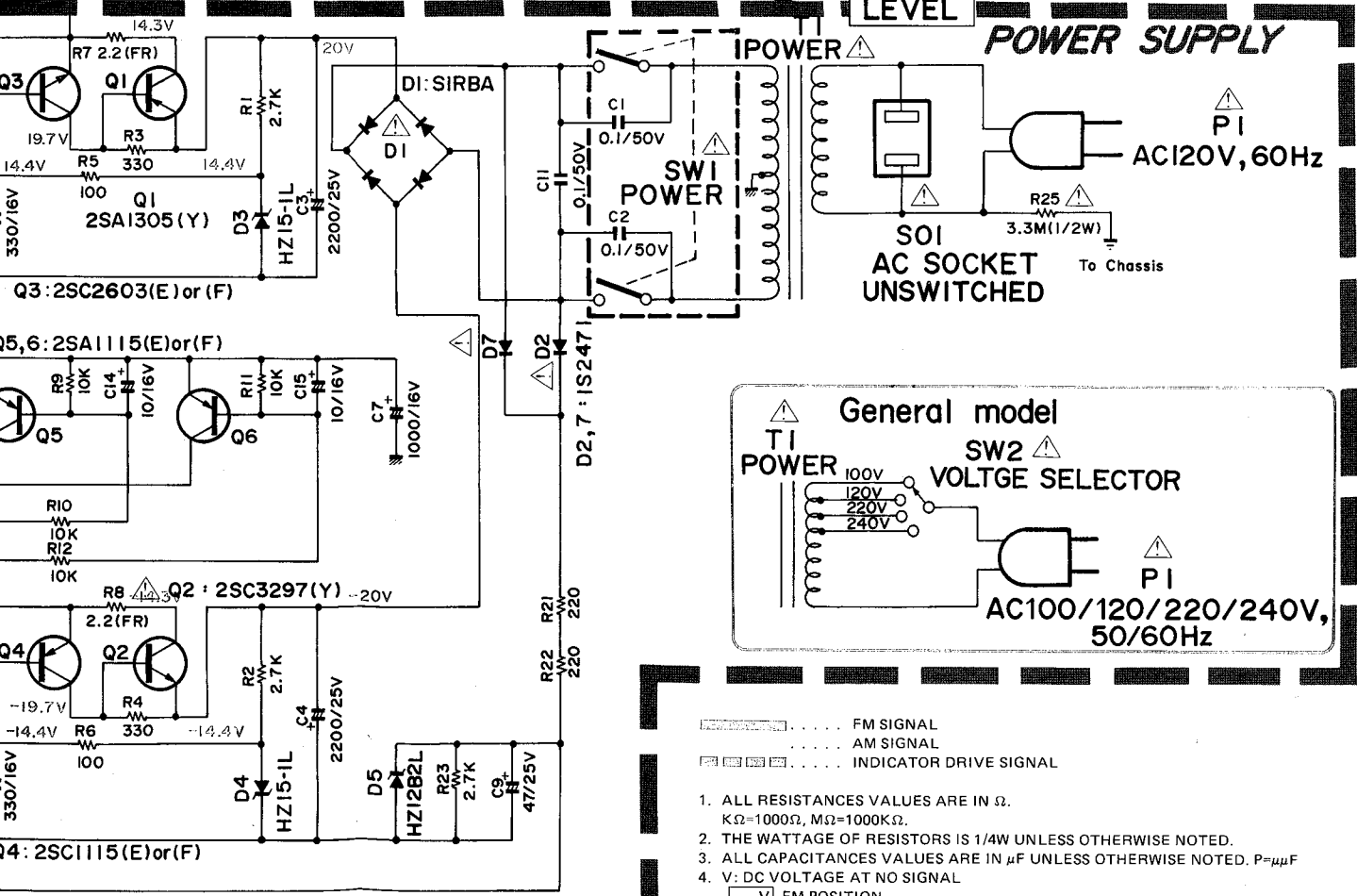
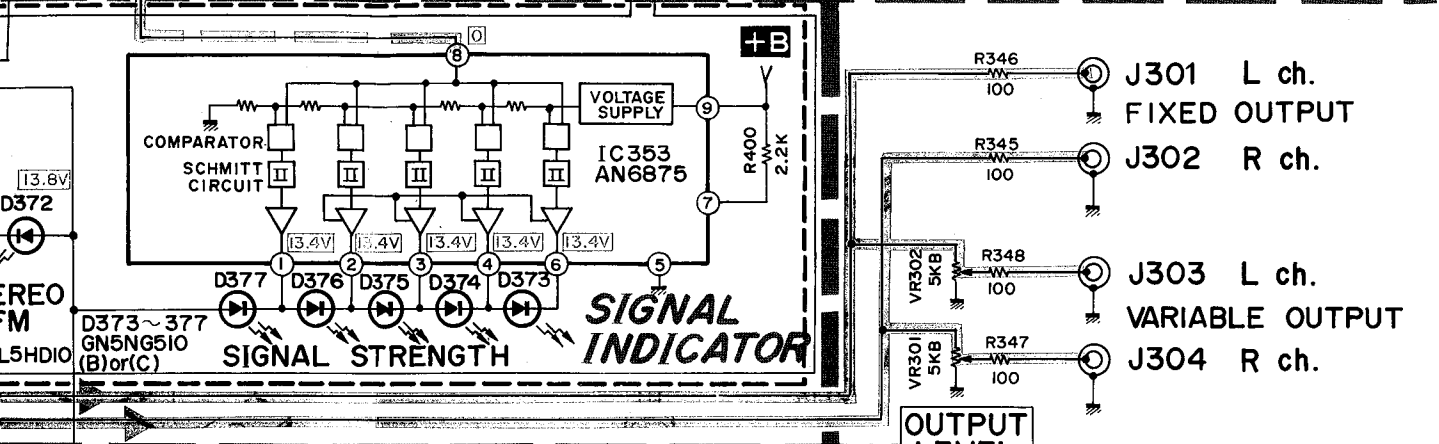
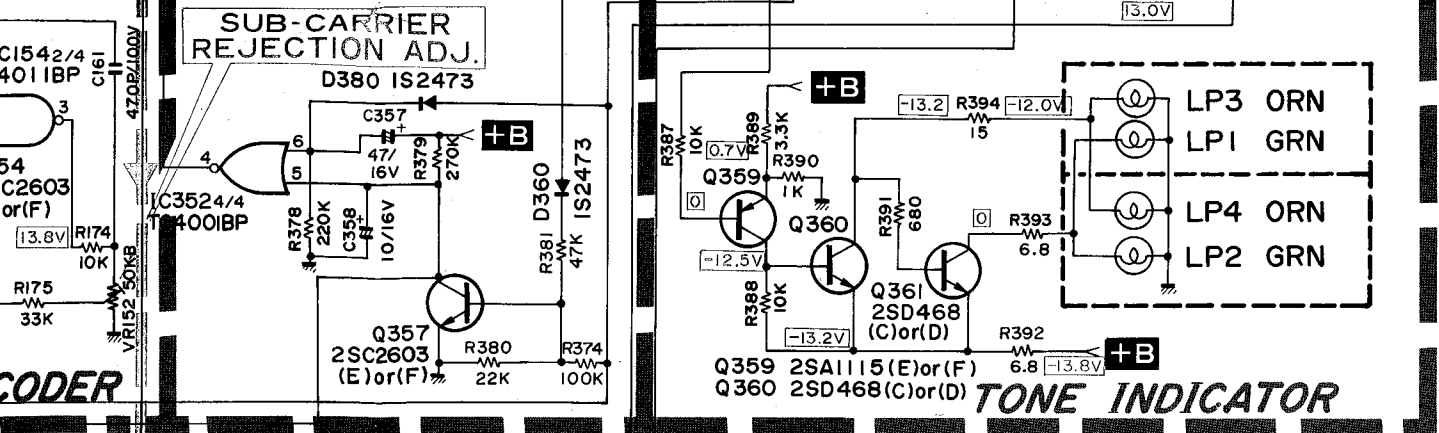

- FM SIGNAL
 - AM SIGNAL
 - INDICATOR DRIVE SIGNAL
1. ALL RESISTANCES VALUES ARE IN Ω.
 KΩ=1000Ω, MΩ=1000KΩ.
 2. THE WATTAGE OF RESISTORS IS 1/4W UNLESS OTHERWISE NOTED.
 3. ALL CAPACITANCES VALUES ARE IN μF UNLESS OTHERWISE NOTED. P=μμF
 4. V: DC VOLTAGE AT NO SIGNAL
 (... V) FM POSITION
 (... V) AM POSITION
 5. SAFETY-REQUIREMENTS COMPONENTS IN ACCORDANCE WITH PRESENT SAFETY REGULATIONS, THESE COMPONENTS MUST ONLY BE REPLACED BY ORIGINAL PARTS.

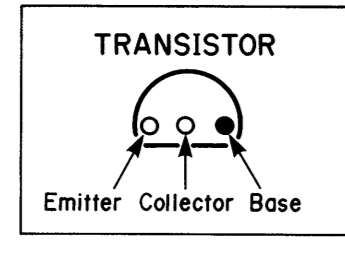
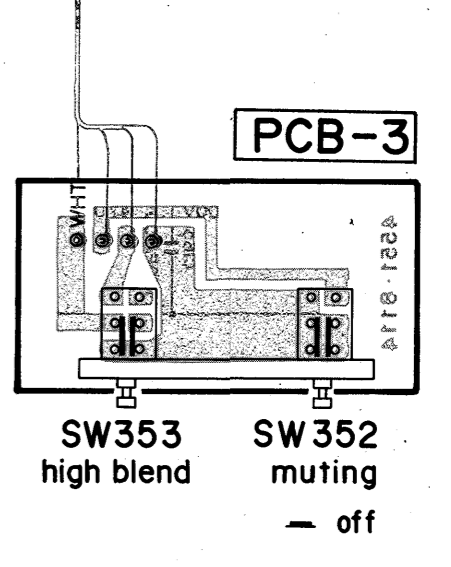
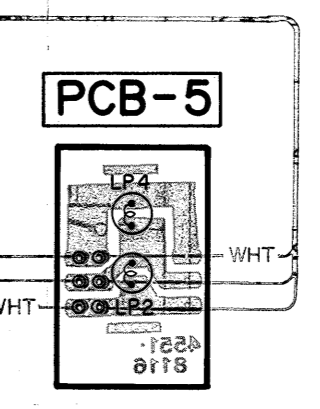
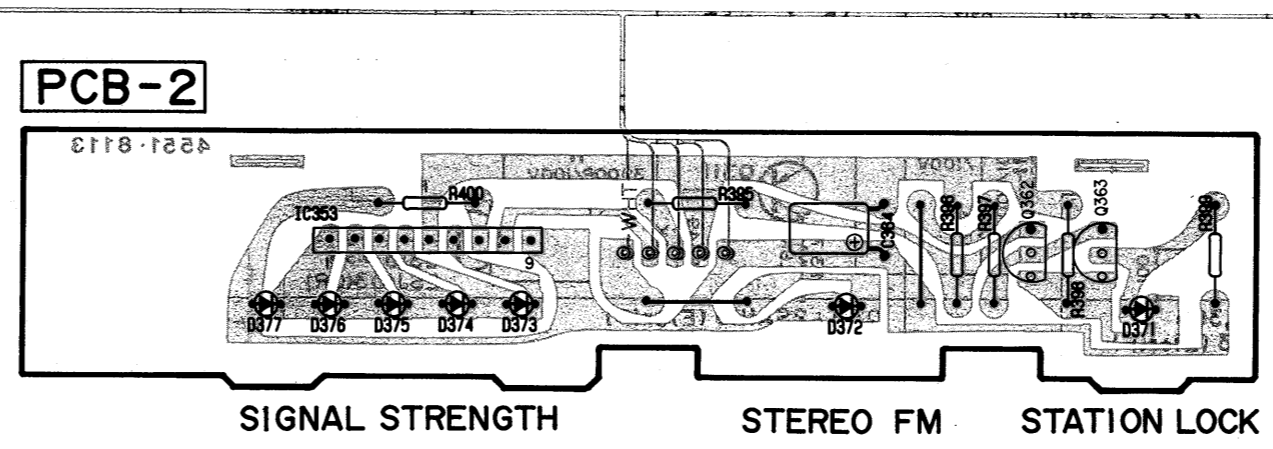
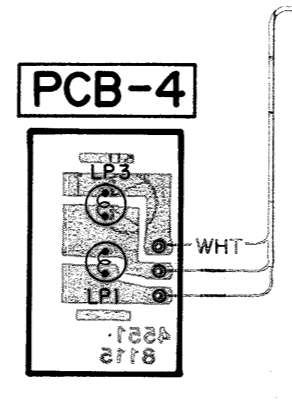
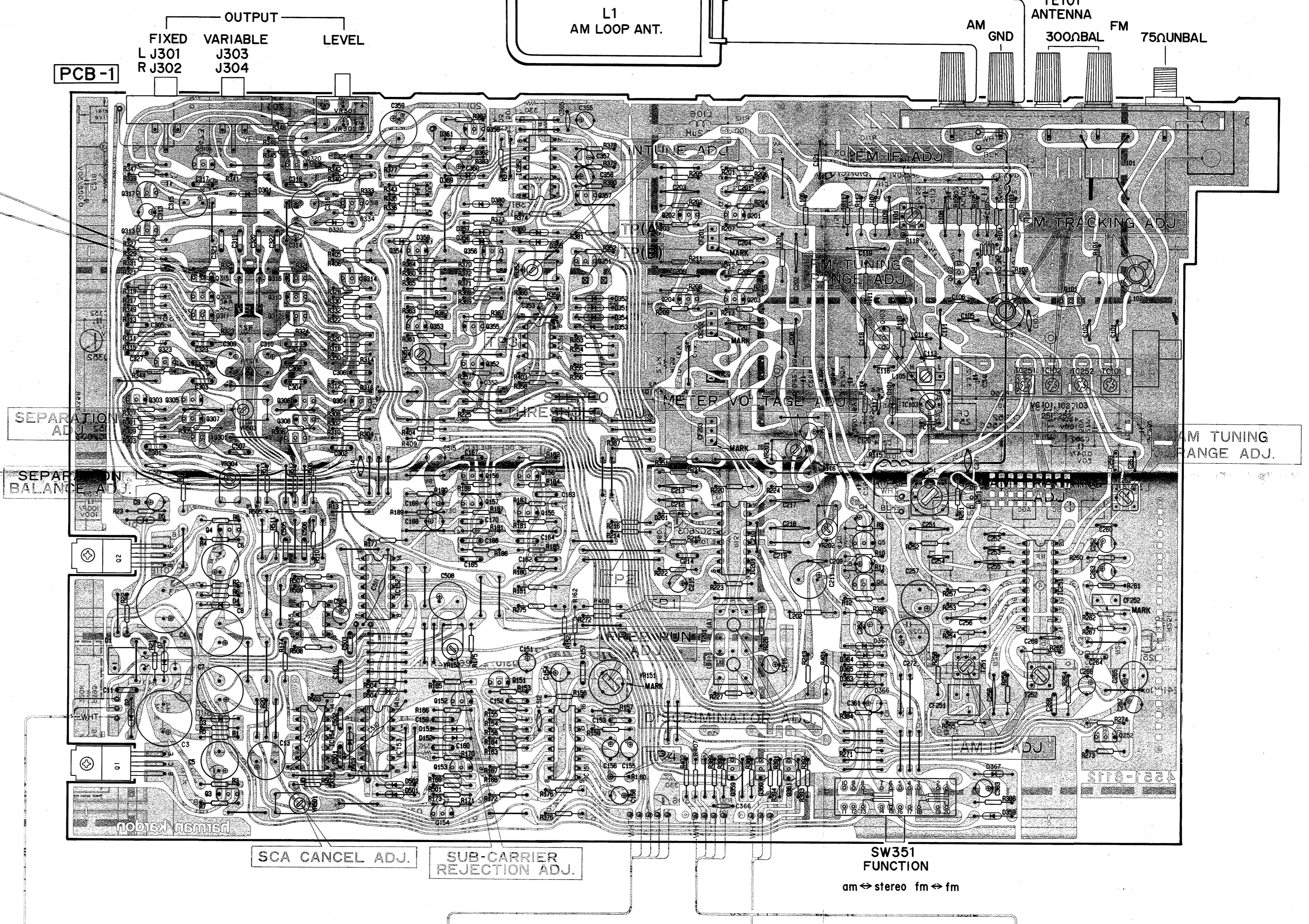
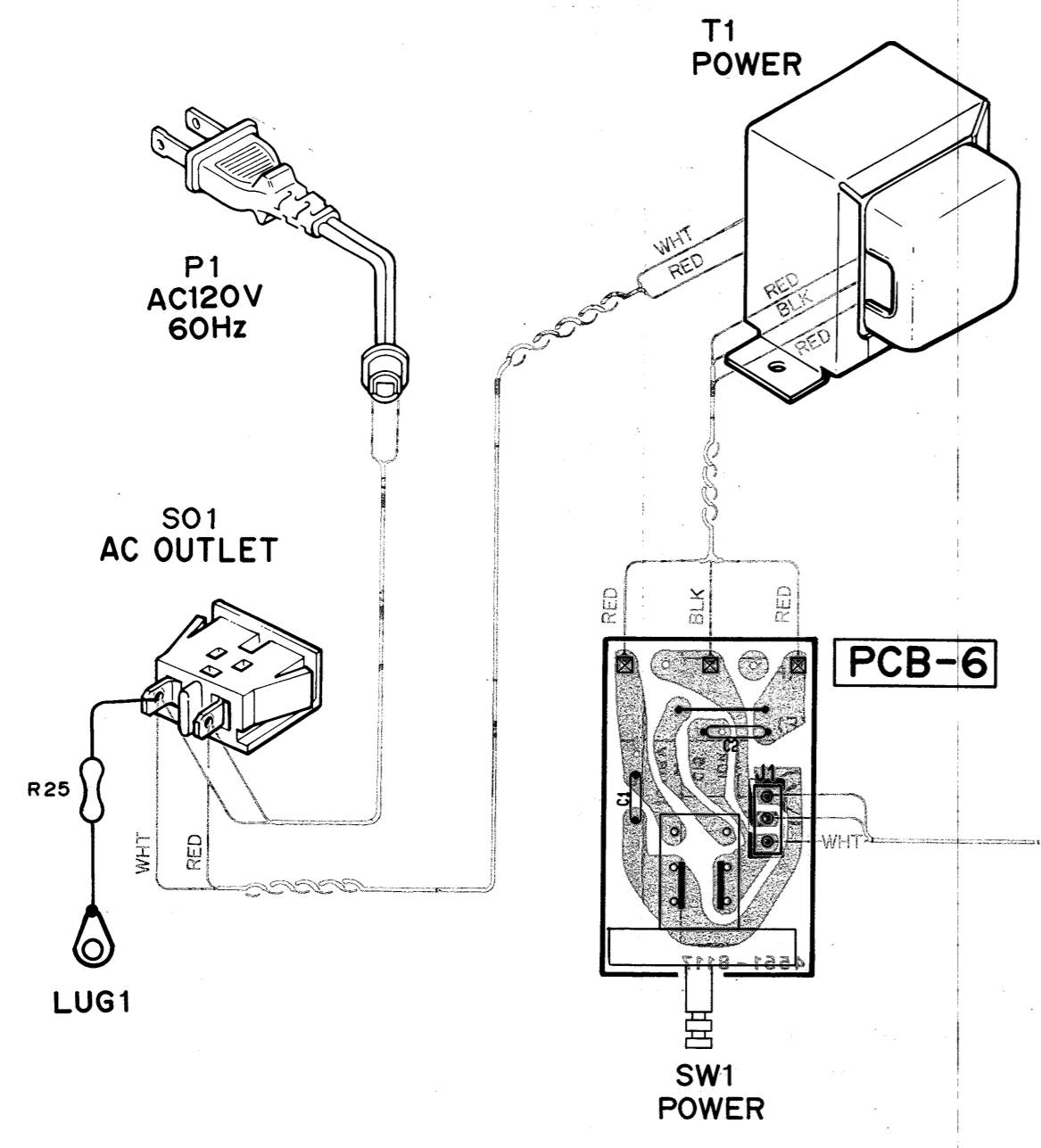
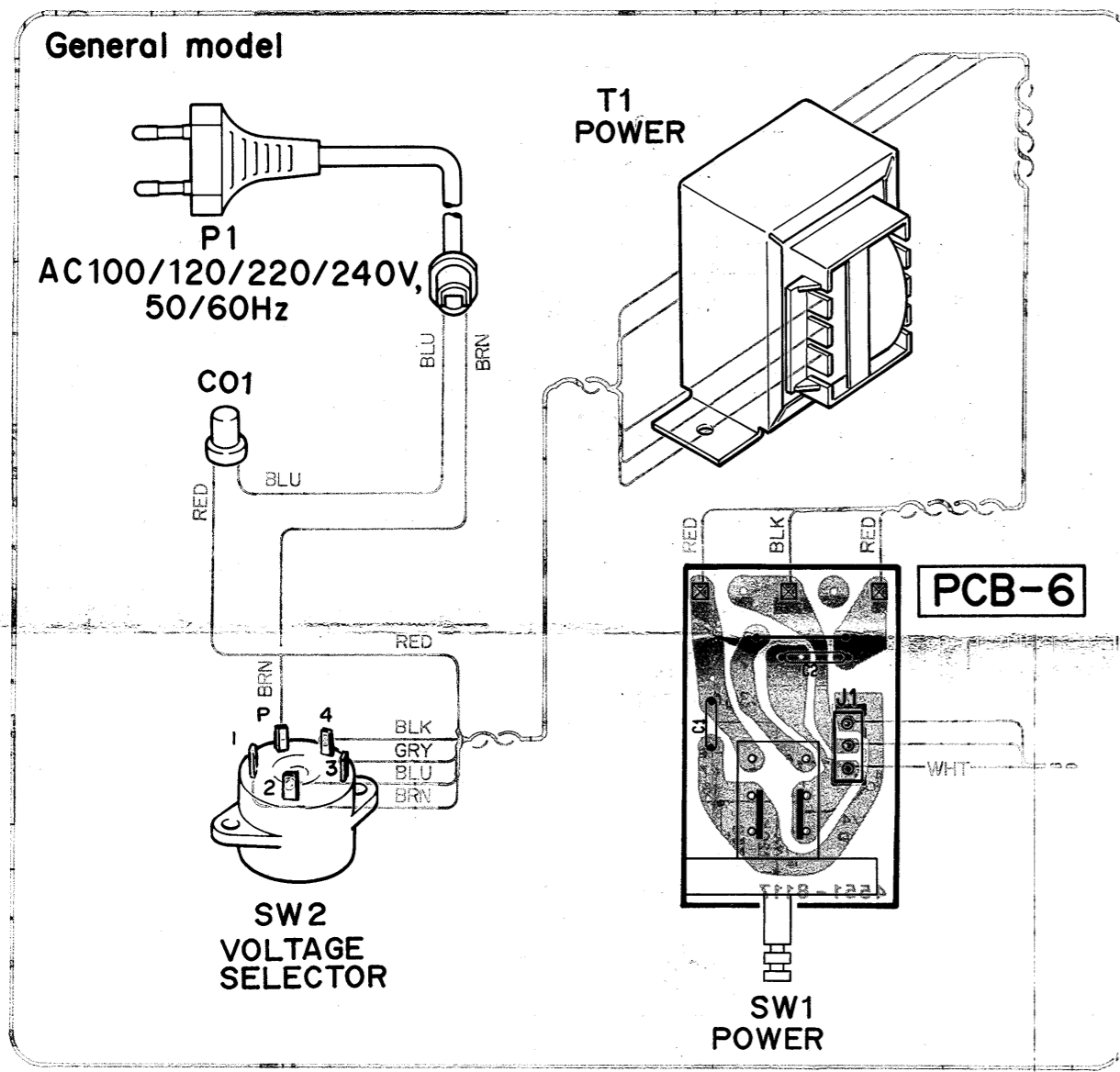
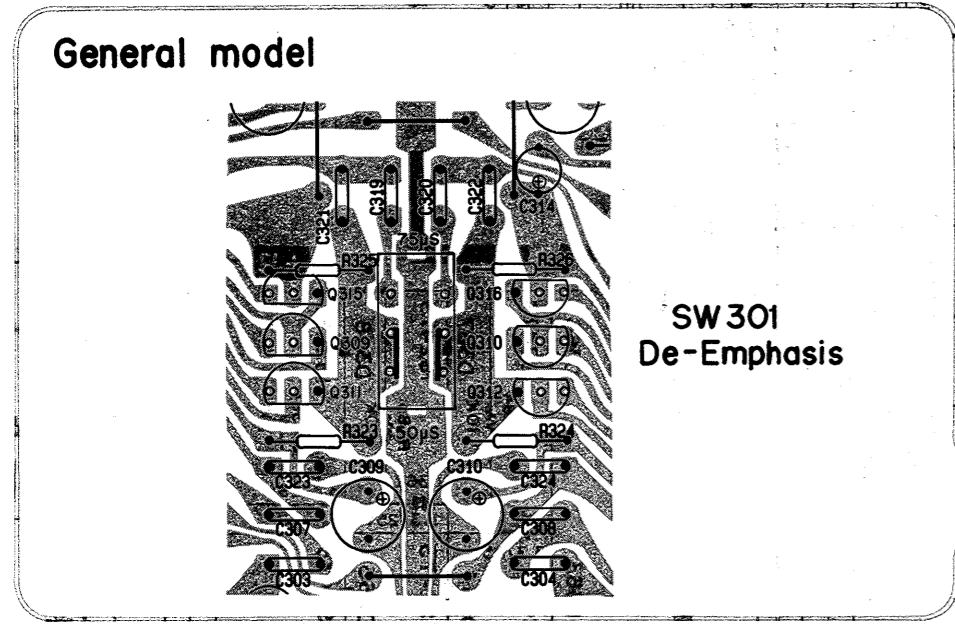

PIN CONNECTION DIAGRAM OF TRANSISTORS, DIODES AND ICs...

2SA1305 2SC3297	2SC2603 2SA1115	2SC5353 2SC461 2SC2056	2SC2878 2SD468	2SK241 2SK381	2SJ103 2SJ74	SIRBA	1S2471 HZ15-1L HZ1282L	1S2236 1S2473	GL5HD10 GL5NG10	BA1330	TC4066BP TC4001BP TC4011BP	MS219P	HA11225	AN6875	LA1245

- WIRE COLOR ABBREVIATIONS**
- RED : Red
 - ORG : Orange
 - BLU : Blue
 - WHT : White
 - GRN : Green
 - BLK : Black
 - YEL : Yellow
 - PUR : Purple
 - PIK : Pink

A B C D
WIRING DIAGRAM

1
2
3
4
5
6

General model

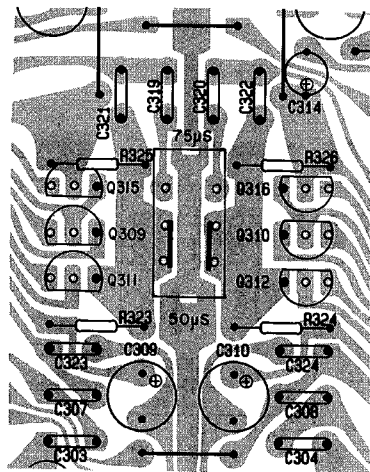

**SW 301
De-Emphasis**

General model

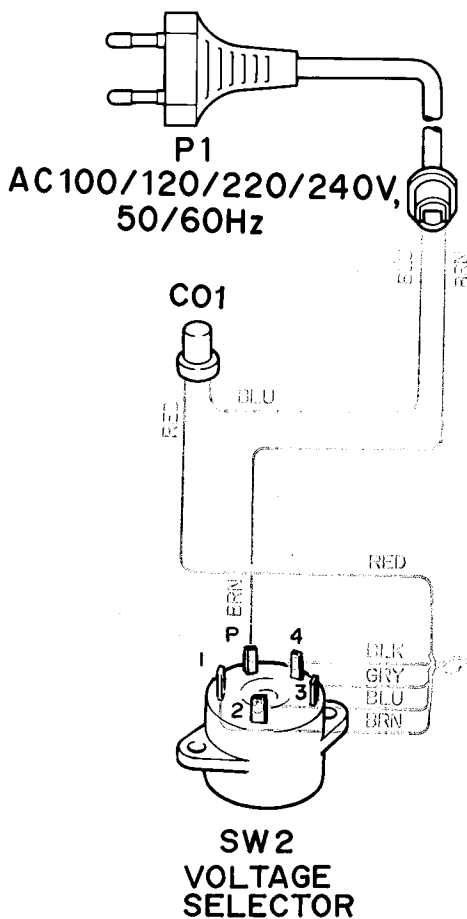

**T1
POWER**

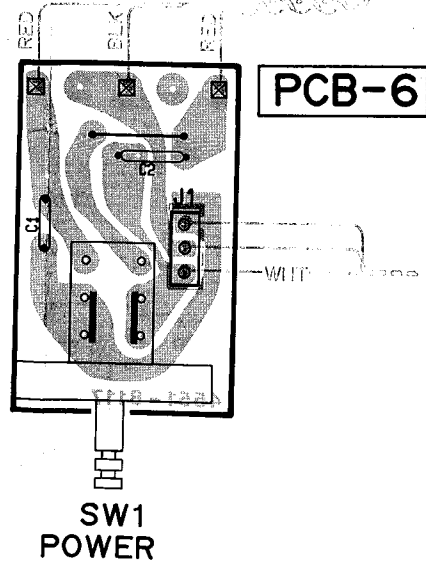
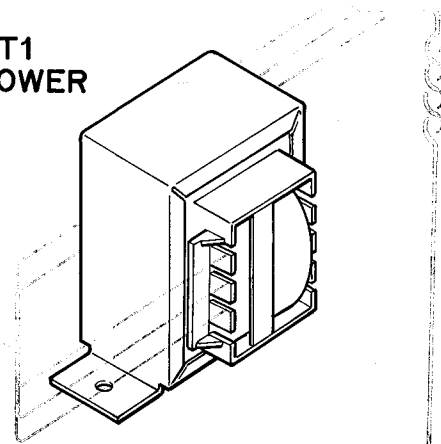

**T1
POWER**

OUTPUT
 FIXED VARIABLE LEVEL
 L J301 J303
 R J302 J304

PCB-1

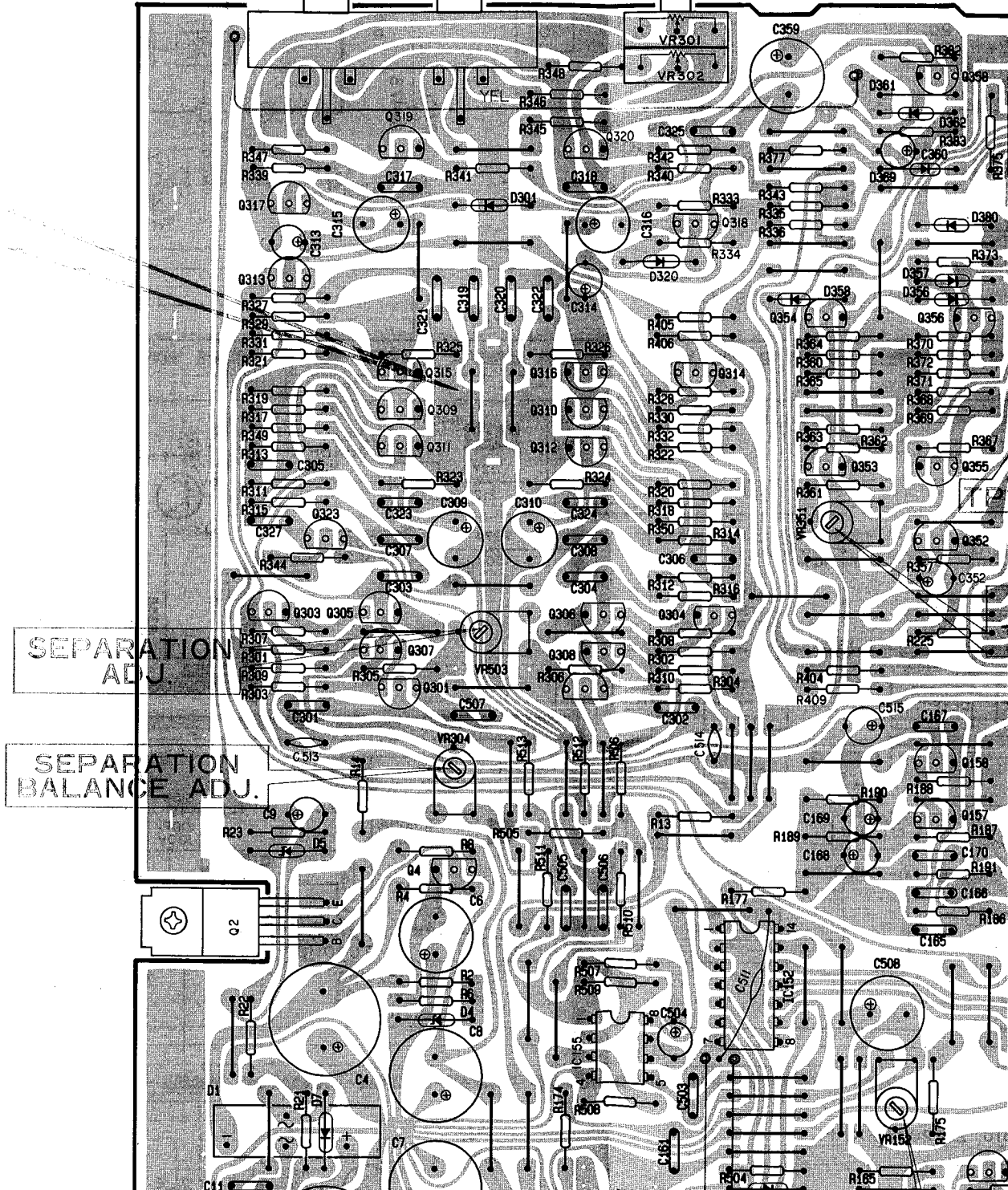

SEPARATION ADJ.

SEPARATION BALANCE ADJ.

PCB-6

L1
AM LOOP ANT.

TE101
ANTENNA
300Ω BAL

AM
GND

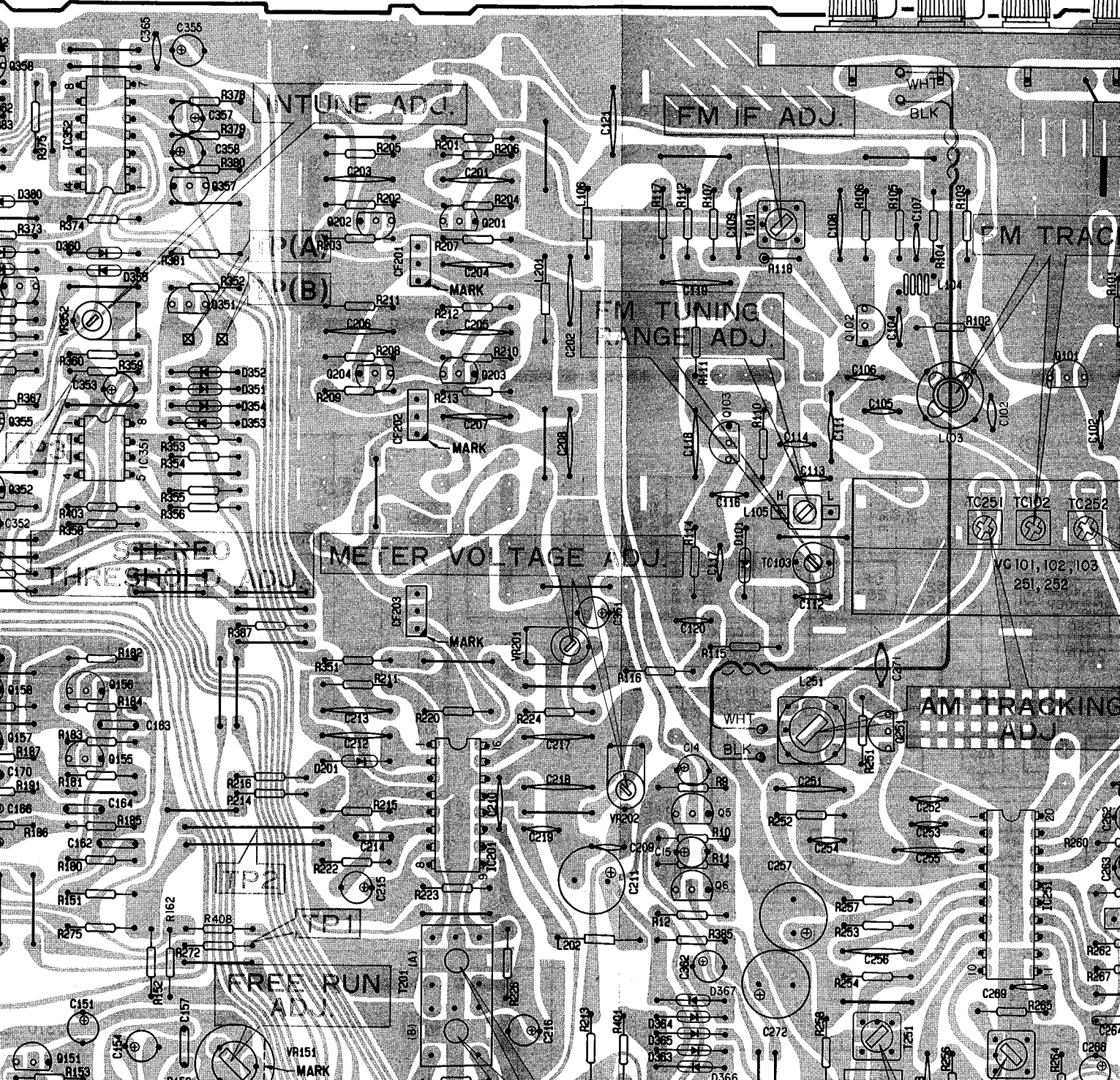

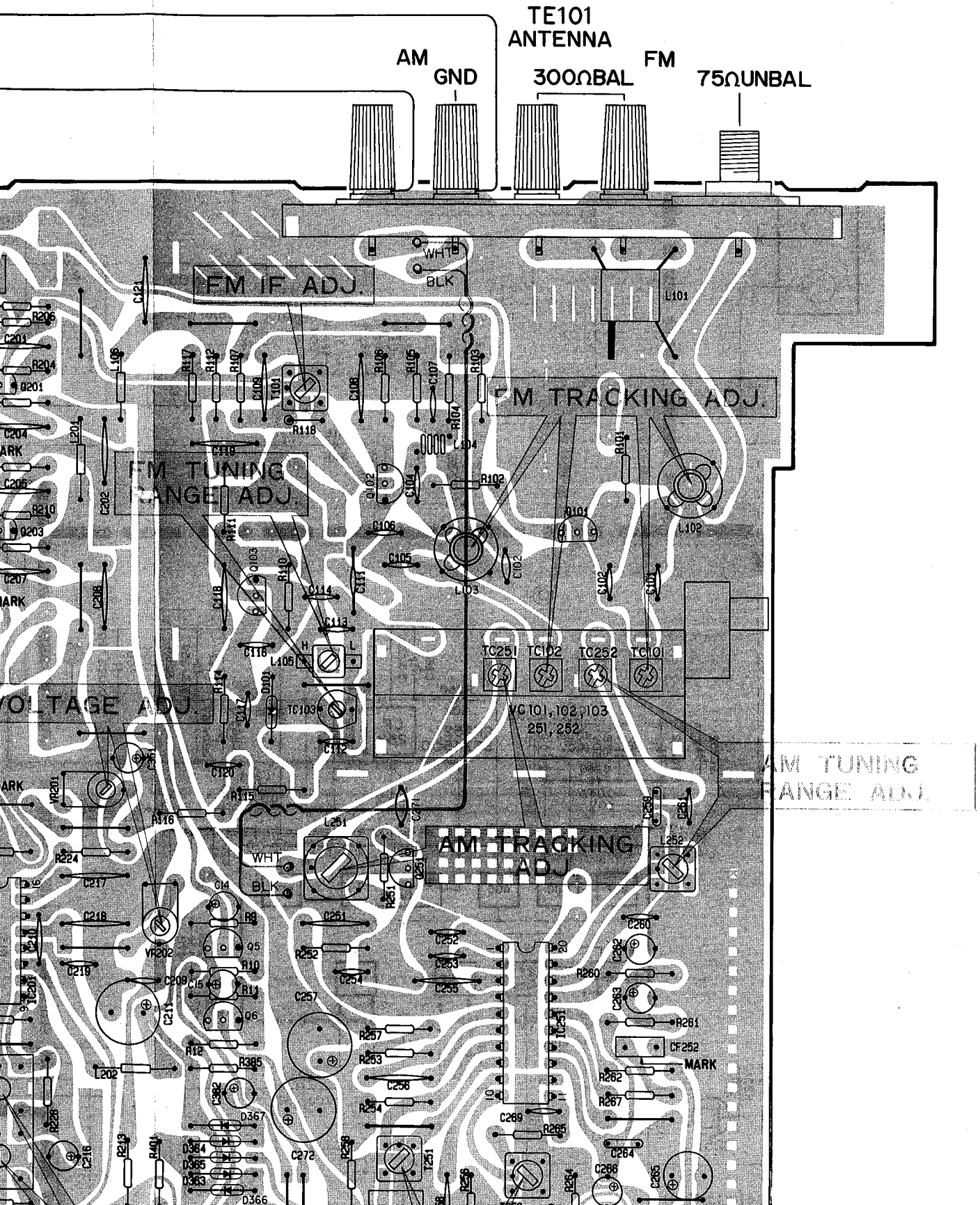

TE101
ANTENNA

AM
GND

300Ω BAL

FM

75Ω UNBAL

FM IF ADJ.

FM TRACKING ADJ.

FM TUNING
RANGE ADJ.

VOLTAGE ADJ.

AM TRACKING
ADJ.

AM TUNING
RANGE ADJ.

VC 101, 102, 103
251, 252

MARK

5

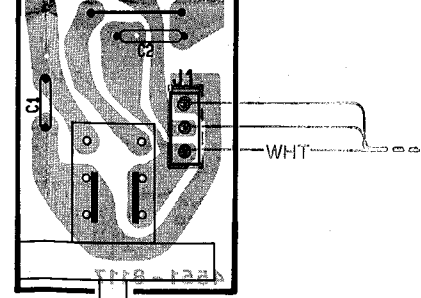
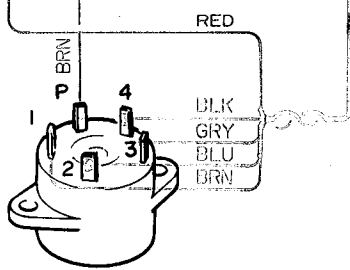

6

T1
POWER

7

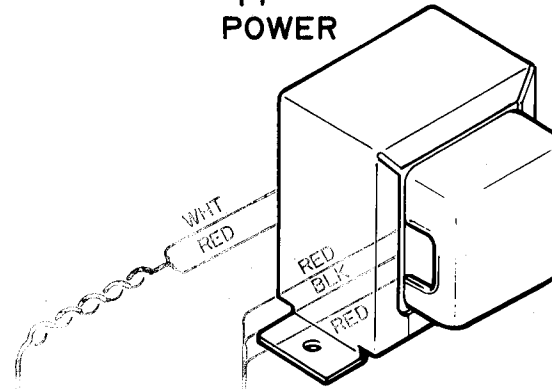
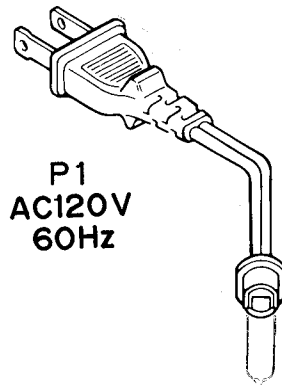

8

S01
AC OUTLET

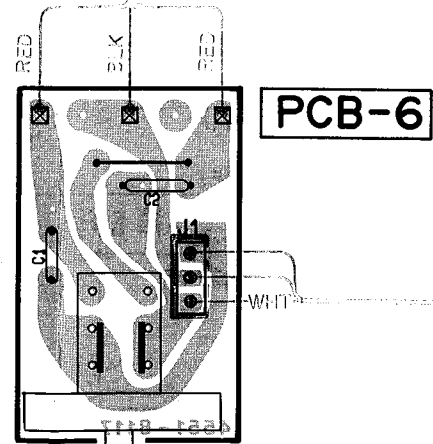
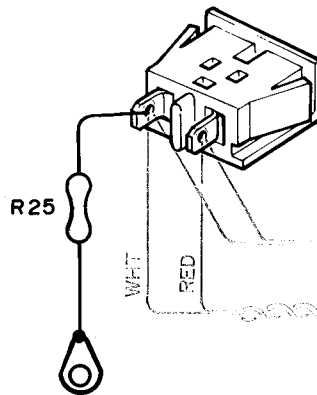

9

SW1
POWER

10

TRANSISTOR

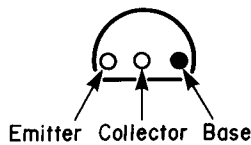

PIN CONNECT

2SA1305
2SC3297

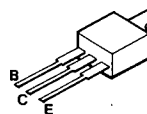

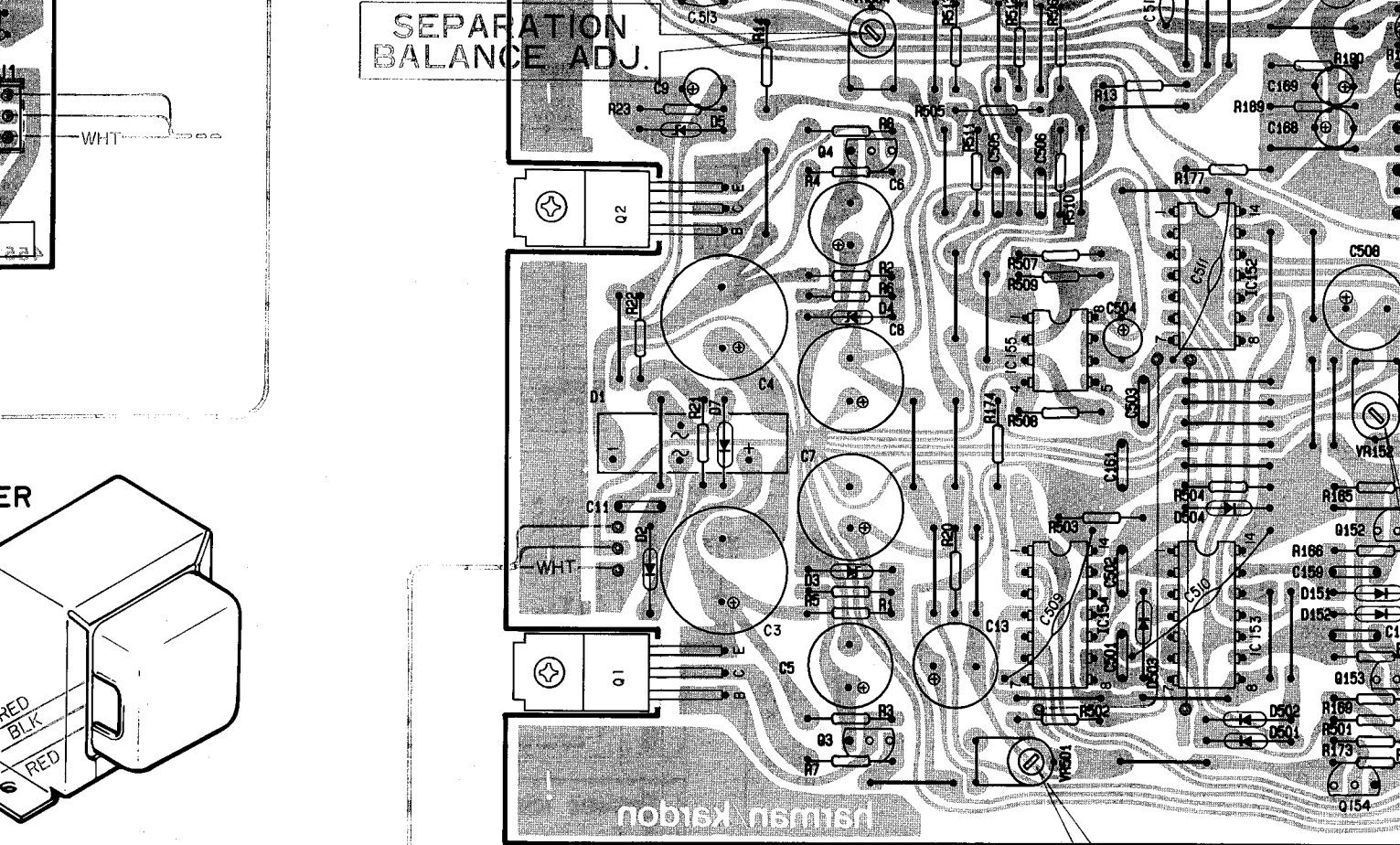

PIN CONNECTION DIAGRAM OF TRANSISTORS, DIODES AND ICS..

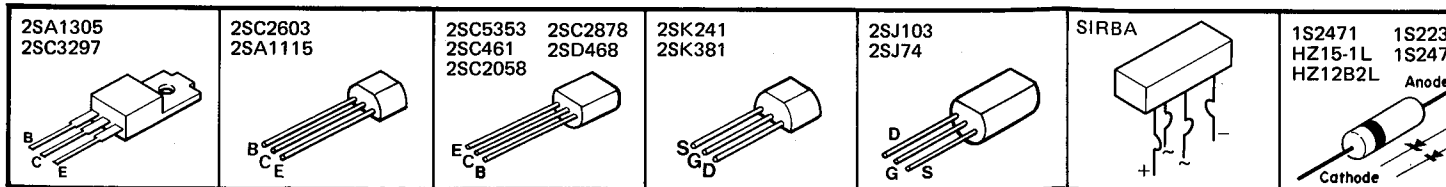

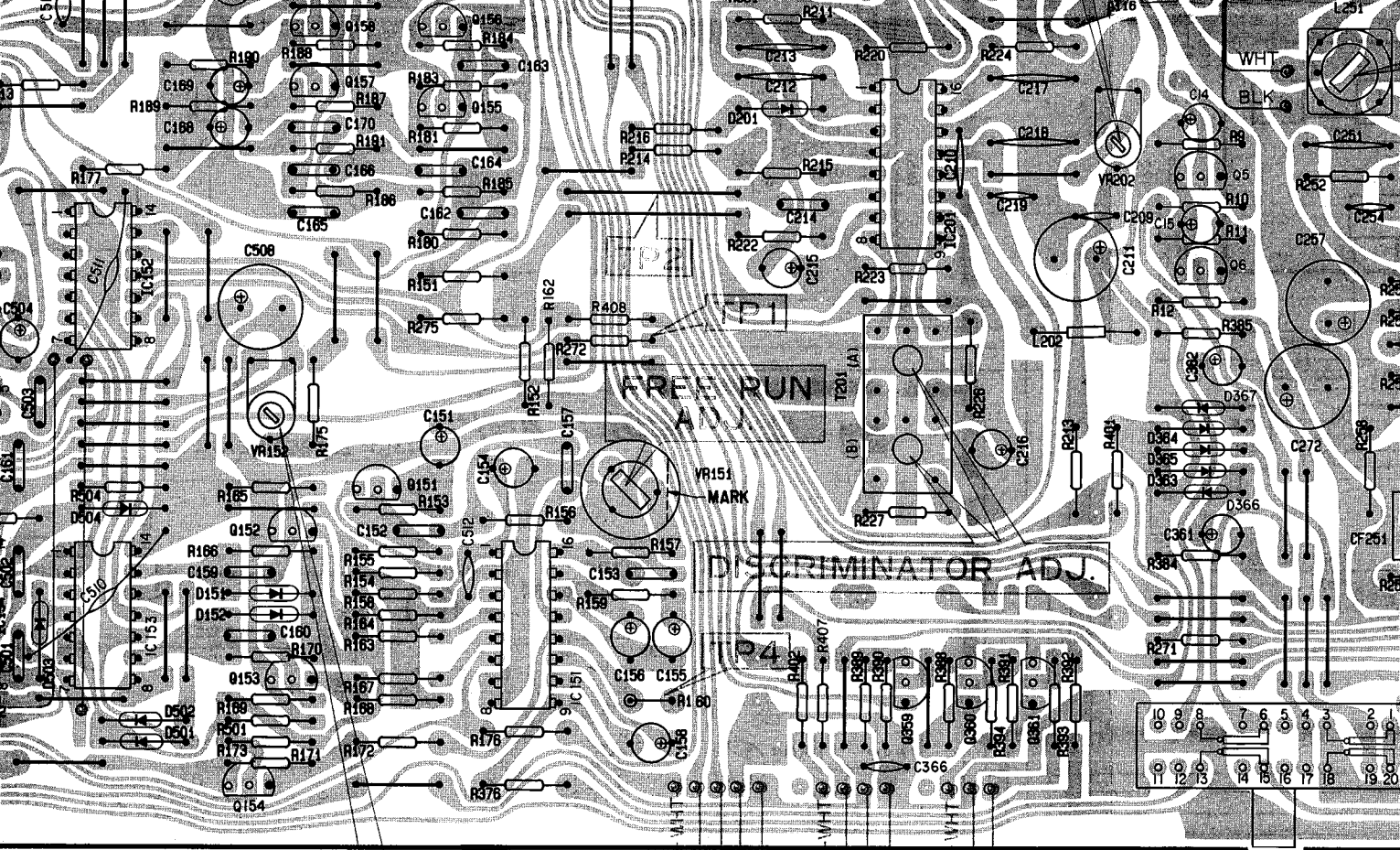

CEL ADJ.

SUB-CARRIER REJECTION ADJ.

SW351 FUNCTION

am ↔ stereo fm ↔ f

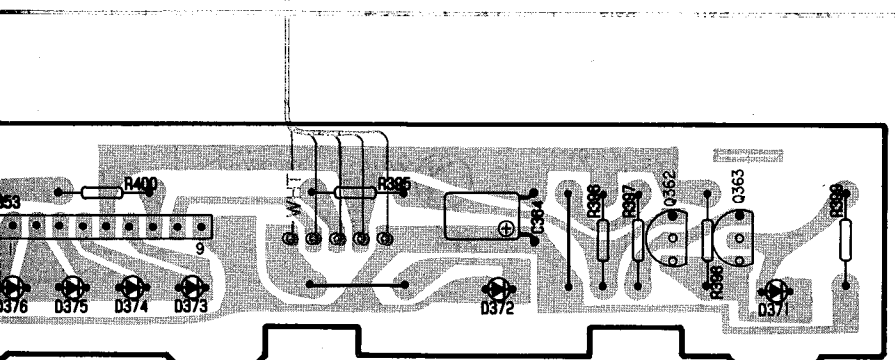

AL STRENGTH

STEREO FM

STATION LOCK

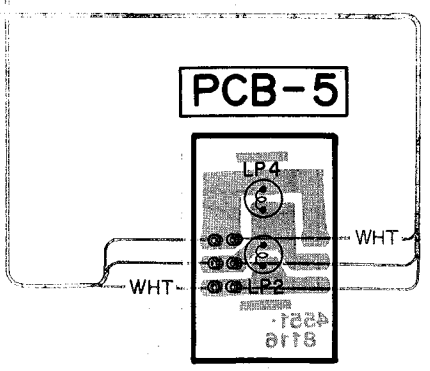

	<p>1S2471 1S2236 HZ15-1L 1S2473 HZ12B2L</p> <p>Anode</p> <p>Cathode</p>	<p>GL5HD10 GL5NG10</p> <p>Cathode</p> <p>Anode</p>	<p>BA1330</p>	<p>TC4066BP TC4001BP TC4011BP</p>	<p>M5219P</p>	<p>HA11225</p>	<p>AN6875</p>
--	---	--	---------------	---------------------------------------	---------------	----------------	---------------

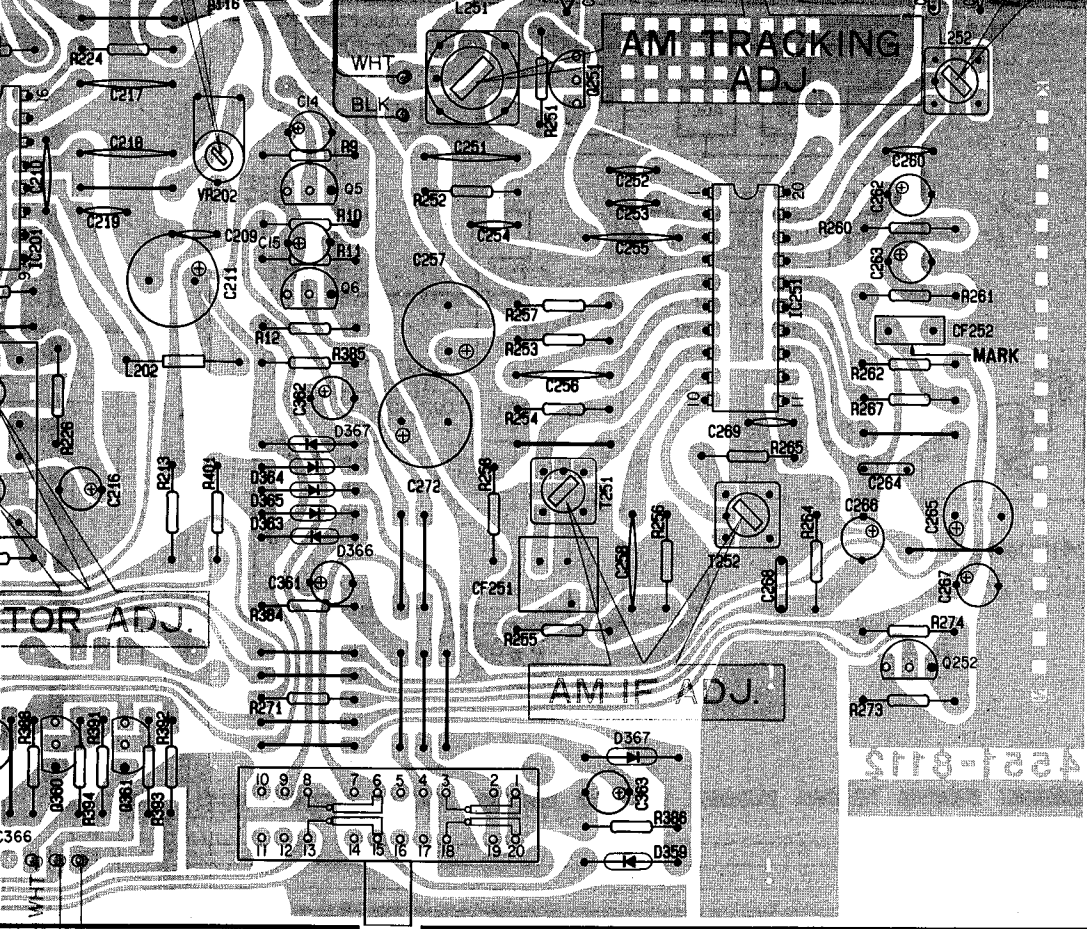

SW351
FUNCTION

am ↔ stereo fm ↔ fm

PCB-5

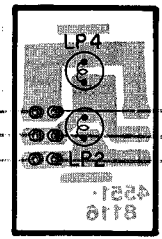

PCB-3

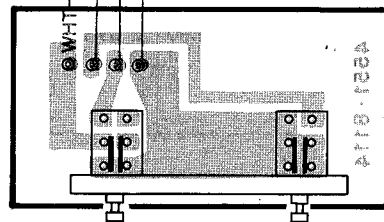

SW353
high blend

SW352
muting

— off

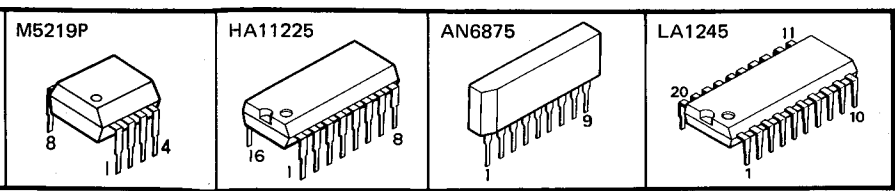

- WIRE COLOR ABBREVIATIONS
- RED : Red
 - ORG : Orange
 - BLU : Blue
 - WHT : White
 - GRN : Green
 - BLK : Black
 - YEL : Yellow
 - PUP : Purple
 - PIK : Pink