

# The Harman Kardon Model TU920

## ACTIVE TRACKING TUNER

Manual 117A

# Technical Manual

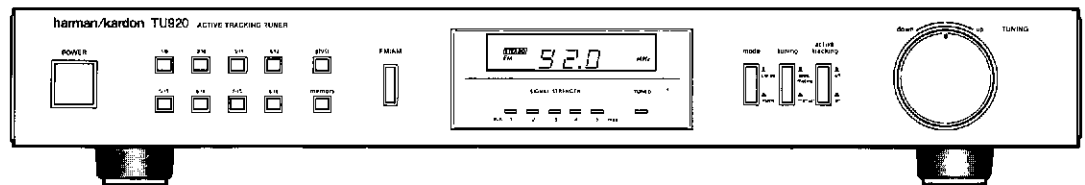

The following marks found in the parts list of this manual identify the models as follows.

- JA : North America area model
- BK : North America area model Black version
- G : General model
- GB : General model Black version

**harman/kardon**

240 Crossways Park West, Woodbury, N. Y. 11797  
1112-3152117A1 P-088709 1500 Printed in Japan

## SPECIFICATIONS

	Nominal	Limit
<b>● FM SECTION</b>		
Tuning range	87.5 ~ 108.0MHz	
50dB Quieting Sensitivity		
Mono	14.2dBf	≧ 19dBf
Mono for active tracking	14.7dBf	≧ 19dBf
Stereo	38.2dBf	≧ 41dBf
Usable Sensitivity	11.7dBf	≧ 15dBf
Image Ratio	49dB	≧ 40dB
IF Rejection	92dB	≧ 75dB
Spurious Response Rejection	94dB	
Capture Ratio	1.5dB	≧ 2dB
Alternate Channel Sensitivity	60dB	≧ 50dB
for active tracking	75dB	≧ 65dB
AM Rejection	59dB	≧ 49dB
Signal to Noise Ratio		
Mono	80dB	≧ 75dB
Stereo	73dB	≧ 68dB
Total Harmonic Distortion		
Mono	0.09%	≧ 0.3%
Mono for active tracking	0.28%	≧ 0.5%
Stereo	0.13%	≧ 0.4%
Stereo for active tracking	0.3%	≧ 0.8%
Stereo Separation at 1 kHz	52dB	≧ 40dB
for active tracking	32dB	≧ 28dB
Output Level/Impedance (Stereo)	750mV/2.2kΩ	

	Nominal	Limit
<b>● AM SECTION</b>		
Tuning range	520 ~ 1,710kHz	
Usable Sensitivity		
External Antenna	14μV	≧ 20μV
Loop Antenna	360μV/m	≧ 700μV/m
Selectivity	33dB	≧ 26dB
Signal to Noise Ratio	53dB	≧ 48dB
Image Rejection	40dB	≧ 30dB
IF Rejection	66dB	≧ 50dB
<b>● DIMENSION</b>	17-7/16" × 2-11/16" × 14-3/16"	
(W × H × D)	(443 × 68 × 360 mm)	
<b>● WEIGHT</b>	7.3 lbs. (3.3 kg)	
<b>● POWER SUPPLIES</b>		
for North America area model	AC 120V, 60Hz	
for General model	AC 220/240V, 50/60Hz	
<b>● POWER CONSUMPTION</b>	14W	

This specification is the target of servicing. But, there is a care that the specification is not applicable to the measurement condition and instrument.

Specifications and components subject to change without notice. Overall performance will be maintained or improved.

## LEAKAGE TEST (FOR SERVICE ENGINEERS IN THE U.S.A.)

Before returning the unit to the user, perform the following safety checks:

1. Inspect all lead dress to make certain that leads are not pinched or that hardware is not lodged between the chassis and other metal parts in the unit.
2. Be sure that any protective devices such as nonmetallic control knobs, insulating fishpapers, cabinet backs, adjustment and compartment covers or shields, isolation resistor-capacity networks, mechanical insulators, etc. which were removed for servicing are properly reinstalled.
3. Be sure that no shock hazard exists; check for leakage current using Simpson Model 229 Leakage Tester, standard equipment item No. 21641, RCA Model WT540A or use alternate method as follows: Plug the power cord directly into a 120-volt AC receptacle (do not use an Isolation Transformer for this test). Using two clip leads, connect a 1500 Ohm, 10-watt resistor paralleled by a 0.15 μF capacitor, in series with all exposed metal cabinet parts and a known earth ground, such as a water pipe or conduit. Use a VTVM or VOM with 1000 Ohms per volt, or higher sensitivity to measure the AC voltage drop across the resistor. (See Diagram.) Move the resistor connection to each exposed metal part having a return path to the chassis (antenna, metal, cabinet, screw heads, knobs and control shafts, escutcheon, etc.) and measure the AC voltage drop across the resistor. (This test should be performed with the power switch in both the On and Off positions.) A reading of 0.35 volt RMS or more is excessive and indicates a potential shock hazard which must be corrected before returning the unit to the owner.

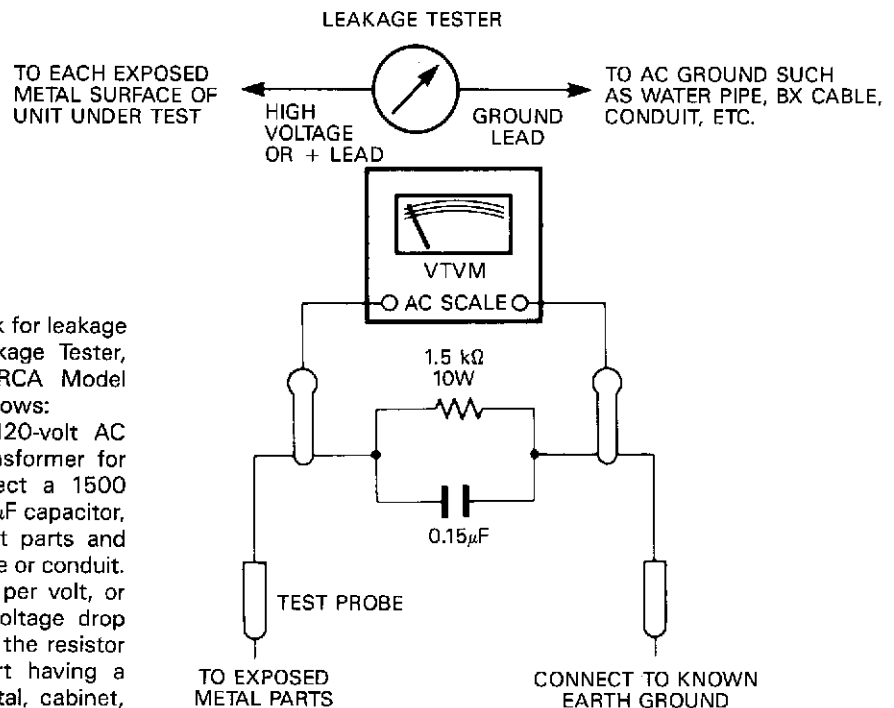

**DISASSEMBLY PROCEDURES (REFER TO PAGES 6 THROUGH 8 AND 11)**

**1 CABINET TOP REMOVAL**

Remove 6 screws (A) and then remove the Cabinet Top (131).

**2 FRONT PANEL ASS'Y (AA) REMOVAL**

1. Remove the Cabinet Top (131), referring to the previous step 1.
2. Remove 7 screws (B) and then remove the Front Panel Ass'y (AA).

**3 MAIN P. C. BOARD (PCB-1) REMOVAL**

1. Remove the Front Panel Ass'y (AA), referring to the previous step 2.
2. Unsolder the lead wires connected to the Main P. C. Board (PCB-1).
3. Remove 8 screws (C) and then remove the Main P. C. Board (PCB-1) with the Preset Switches and Tuning Switches P. C. Boards (PCB-2 and PCB-3) Chassis (173), etc.
4. Remove 2 screws (D) and then remove the Chassis (173) with PCB-2 and PCB-3.

**POWER CORD REPLACEMENT (FOR SERVICE ENGINEERS OTHER THAN NORTH AMERICA)**

In order to prevent fire or shock hazard when replacing the power cord, follow the procedure below to replace the part with the standard supply parts.

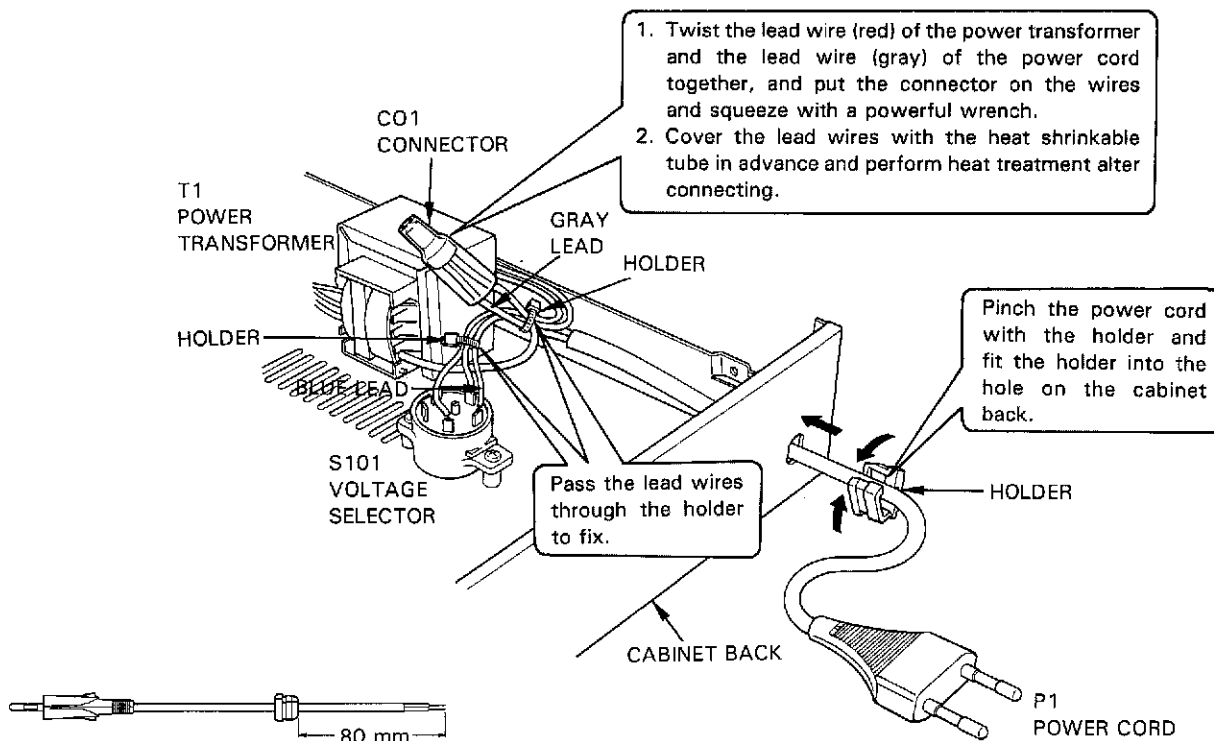

**ALIGNMENT PROCEDURES (REFER TO PAGES 9, 10, 17 AND 18)**

**AM ADJUSTMENT**

- Conditions :
- Set the AM mode by pressing the "FM/AM" button.
  - Press the "mode" switch to the "mono" (button in) position.
  - Standard modulation of the AM signal Generator is 400Hz at 30%.

Step	Alignment	Connection Equipments	Measurement Frequency	Station Display	Adjustment	For
1	IF	<ul style="list-style-type: none"> <li>• Connect the AM Test Loop Antenna cable into the output jack of AM Signal Generator.</li> <li>Place AM Test Loop Antenna close enough to couple signal into the AM Loop Antenna.</li> <li>• Connect the VTVM and oscilloscope to the OUTPUT jacks.</li> </ul>	1400kHz	1400kHz	T251	Maximum output level and symmetrical curve on scope.
2	Tracking		1400kHz	1400kHz	TC251	Maximum output.
3			600kHz	600kHz	L251	Maximum output.
4			Repeat steps 2 and 3 for optimum sensitivity.			
5			Tuned indicator	1000kHz	1000kHz	

## FM ADJUSTMENT

Conditions : ● Set the FM mode by pressing the "FM/AM" button.

- Press the "mode" switch to the "mono" (button in) position.

	U.S.A. model	General model
FM Signal Generator	1kHz, 100% modulation	1kHz, 45% modulation
Stereo Modulator	L + R = 45.5%, L - R = 45.5%, 19kHz = 9%	L + R = 22.5%, L - R = 22.5%, 19kHz = 8%

Step	Alignment	Connection Equipments	Measurement Frequency	Station Display	Adjustment	For
1	Discriminator	<ul style="list-style-type: none"> <li>● Connect the FM Signal Generator to FM 300Ω BAL Antenna terminals through the 300Ω balanced dummy. [1mV(65dBf) input]</li> <li>● Connect the Oscilloscope and Distortion meter to the OUTPUT jacks.</li> </ul>	98.1MHz ± 30 ~ 40kHz	98.1MHz	T201(A)	Adjust so that the TUNED indicator lights in the same range on both plus (+) and minus (-) sides of 98.1MHz.
2			98.1MHz	98.1MHz	T201(B)	Minimum distortion.
3			Repeat steps 1 and 2 for optimum sensitivity.			
4	Tuned indicator		98.1MHz	98.1MHz	VR351	Adjust so that the TUNED indicator lights at 22μV input. (32μV/75Ω input for General model)
5	Signal indicator		98.1MHz	98.1MHz	VR351	Adjust so that the five SIGNAL STRENGTH indicator lights at 450μV input. (500μV/75Ω input for General model)
6	Active tracking		98.1MHz	98.1MHz	L241 TC241	Adjust L203 so that the upper and lower parts of the waveform are symmetrical and TC241 so as to obtain the waveform immediately before clipping.
7	Tuned indicator		98.1MHz	98.1MHz	VR352	Adjust so that the TUNED indicator lights at 20μV input. (32μV/75Ω input for General model)
8	Signal indicator		98.1MHz	98.1MHz		Confirm the five SIGNAL STRENGTH indicator lights at 500μV input. (500μV/75Ω input for General model)
9	Separation	<ul style="list-style-type: none"> <li>● Connect the Stereo Modulator to FM Signal Generator. Connect FM Signal Generator to FM 300Ω BAL Antenna terminal through the 300Ω balanced dummy.</li> <li>● Connect the VTVM and Oscilloscope to the OUTPUT jacks.</li> <li>● Press the "mode" switch to the "stereo" (button out) position.</li> </ul>	98.1MHz	98.1MHz	VR301	Adjust so that the left channel output becomes minimum when only the right channel of the Stereo Modulator is modulated.
					VR301	Adjust so that the right channel output becomes minimum when only the left channel of the Stereo Modulator is modulated.
10	Normal AGC voltage	<ul style="list-style-type: none"> <li>● Contact the FM Signal Generator to FM 300Ω BAL Antenna terminals through the 300Ω balanced dummy. (1000μV/75Ω input)</li> </ul>	98.1MHz	98.1MHz	VR101	Adjust so that voltage becomes 1.7V.
11	Active tracking AGC voltage	<ul style="list-style-type: none"> <li>● Connect the VTVM to TP1(+) and ground(-).</li> </ul>	98.1MHz	98.1MHz	VR102	Adjust so that voltage becomes 1.7V.

## CIRCUIT DESCRIPTION

### ■ FM TUNER SECTION

The FM signal which has entered through the antenna is high-frequency amplified in the front end FE101, mixed with the output of the local oscillator and converted into the 10.7MHz intermediate-frequency.

The 10.7MHz signal is amplified in the intermediate-frequency amplifying section which consists of CF201, Q201 and CF202 and fed to 1 pin of IC201. In IC201, the signal is transmitted through the IF amplifier in two steps, and after being detected in the quadrature, it is transmitted through the post amplifier to 12 pin and then input to 2 pin of IC301. In IC301, the pilot signal is detected out of the signal which has been fed and 38kHz signal is produced. Then by this signal, stereo signal is demodulated, output from 4 pin for the left channel and from 7 pin for the right channel be fed to the amplifier.

### ■ ACTIVE TRACKING CIRCUIT

When FM reception is poor because the tuned frequency is interfered by some other strong FM signal nearby, turning ON the active tracking switch causes the signal from the tuned station to come out of IF AMP Q201 and pass through D202, CF203, IF AMP Q202 and CF204. Then it is fed to 1 pin of IC202 where its phase compared with the phase of the VCO output signal composed in Q204, D205 and L241, by the phase comparison device included in IC202. The output signal of the phase comparison device is sent out from 7 pin of IC202, transmitted through LPF consisting of Q203, R239 and C238 back to D205. As this forms the PLL circuit, the VCO output signal follows the signal within the PLL lock range only and that signal is sent through D204 to 1 pin of IC201.

### ■ AM TUNER SECTION

The AM signal which has entered through the antenna is transmitted through the tuning circuit consisting of L251 and TC251 to IC201. IN IC201 it undergoes high-frequency amplification, intermediate-frequency amplification local oscillation, intermediate-frequency amplification and detection, and then output from 15 pin. This signal is turned ON and OFF at Q703 and Q704 according to the signal from the input selector and fed to 2 pin of IC301.

### ■ MUTING CIRCUIT

If FM is received out of tuning or in a very weak field intensity, 28 pin of IC702 becomes high level. This is fed to the base of Q351, whose collector then becomes low level and the collector of Q4 high level. As a result, Q301 (L ch) and (R ch) are conducted to mute the output.

### ■ SYNTHESIZER SECTION

#### ● FM

The local oscillation output at the front end is fed to 5 pin of the prescaler IC701 and after being frequency divided into 30 or 32, it is fed to 37 pin of the PLL synthesizer IC702. In IC702, the standard frequency is oscillated by the crystal oscillator, compared with the divided local oscillation output signal and output to 34 pin. This voltage is level converted at Q701 and Q702, and fed to the varicap diode at the front end.

#### ● AM

The local oscillation output is fed from 24 pin of IC201 to 39 pin of IC702. In IC702, the standard frequency is oscillated by the crystal oscillator, compared with the local oscillation output and output to 34 pin.

### ■ INDICATOR SECTION

#### ● FREQUENCY DISPLAY

The serial data sent out of 27 pin of the PLL synthesizer IC702 is fed to 2 pin of the frequency indicating driver IC751, where the data is decoded to provide a signal which turns ON the indicator.

#### ● SIGNAL STRENGTH

The voltage corresponding to the signal level is output from 16 pin of IC201 and input into 8 pin of the level comparator IC351. D361, D362, D363, D364 and D365 of the signal strength indicator turn ON according to the signal level.

#### ● TUNING

8 pin of IC201 becomes low level when tuned and the tuned indicator D366 connected there turns ON.

## BLOCK DIAGRAM

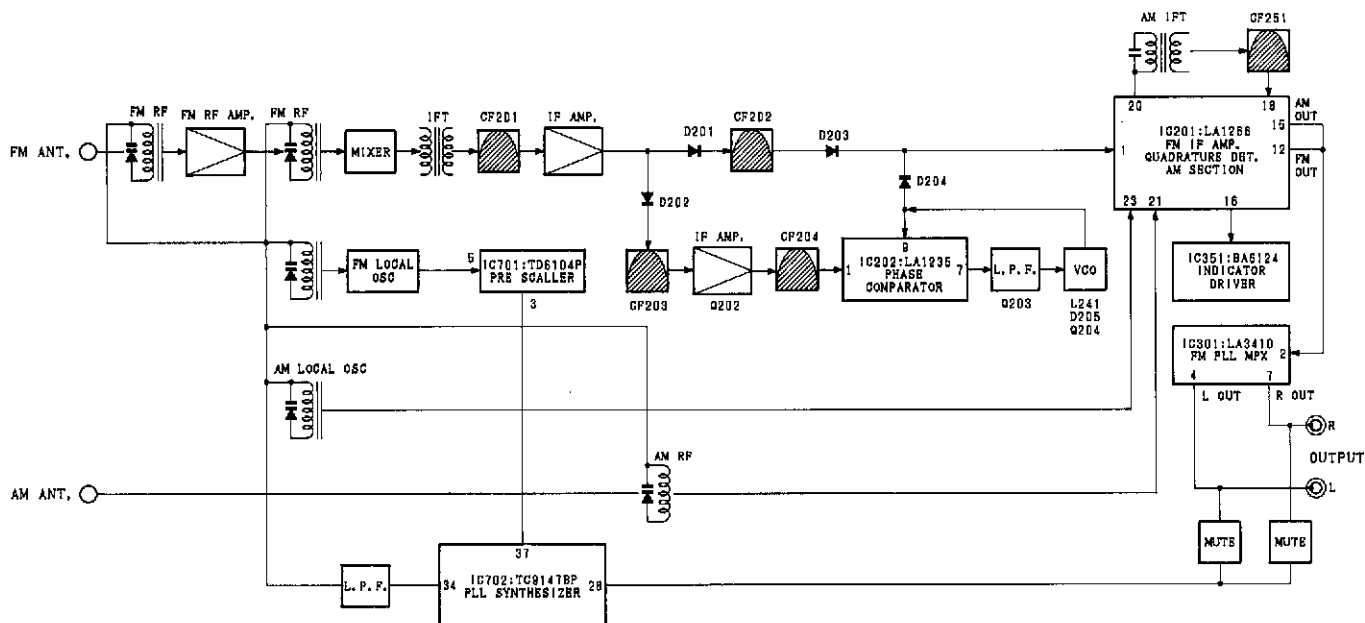

**GENERAL UNIT**  
EXPLODED VIEW (FRONT CHASSIS)

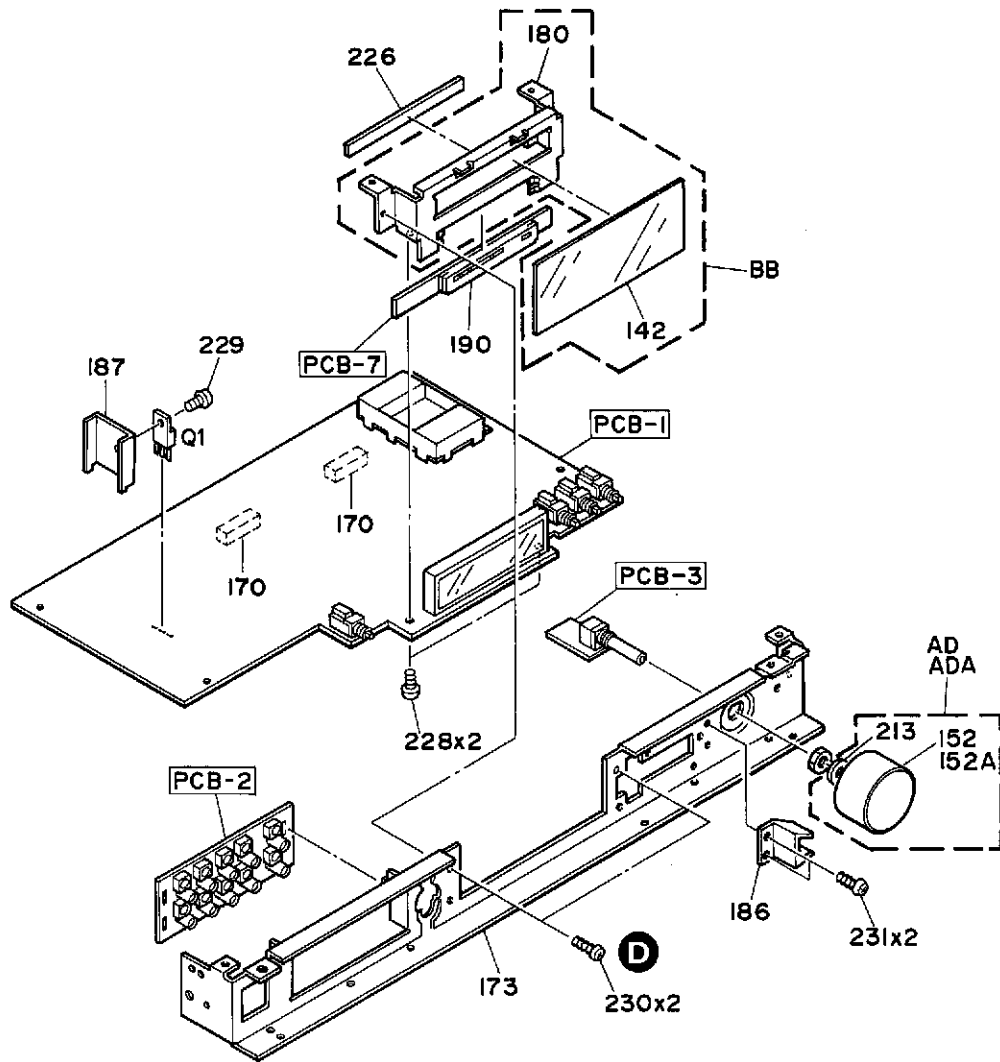

**PARTS LIST**

Ref. No.	Part No.	Description
AD	A630-TU920A	ROTARY KNOB ASS'Y UA G
ADA	A630-TU920B	ROTARY KNOB ASS'Y BK GB
BB	B219-TU920A	METAL FITTG ASS'Y
142	1531-09401	WINDOW
152	1630-03401	ROTARY KNOB UA G
152A	1630-03402	ROTARY KNOB BK GB
170	2112-11787	SPONGE
173	2211-7278	CHASSIS
180	2219-8001	METAL FITTG
186	2219-8128	METAL FITTG
187	2222-7197	HEAT SINK
190	2240-7317	HOLDER
213	2651-110518	SPRING
226	2111-11160	FELT
228	2327-R0130062	SCREW
229	2327-R0130082	SCREW
230	2347-R0130062	SCREW
231	2347-R0130062	SCREW
Q1	5614-1666(R)	TRANSISTOR

A B C D E

# GENERAL UNIT

EXPLODED VIEW

1  
2  
3  
4  
5  
6  
7

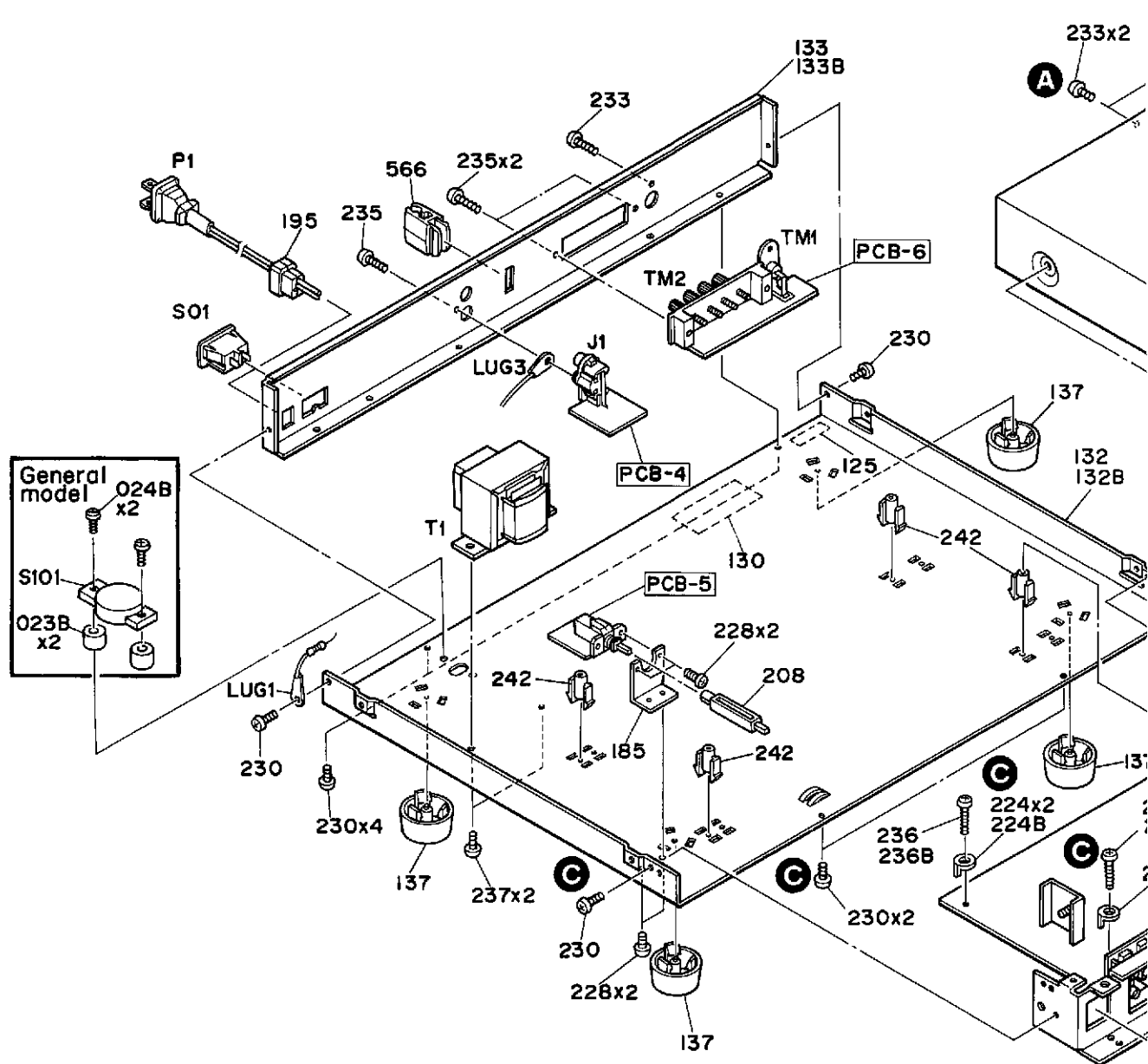

F

G

H

I

J

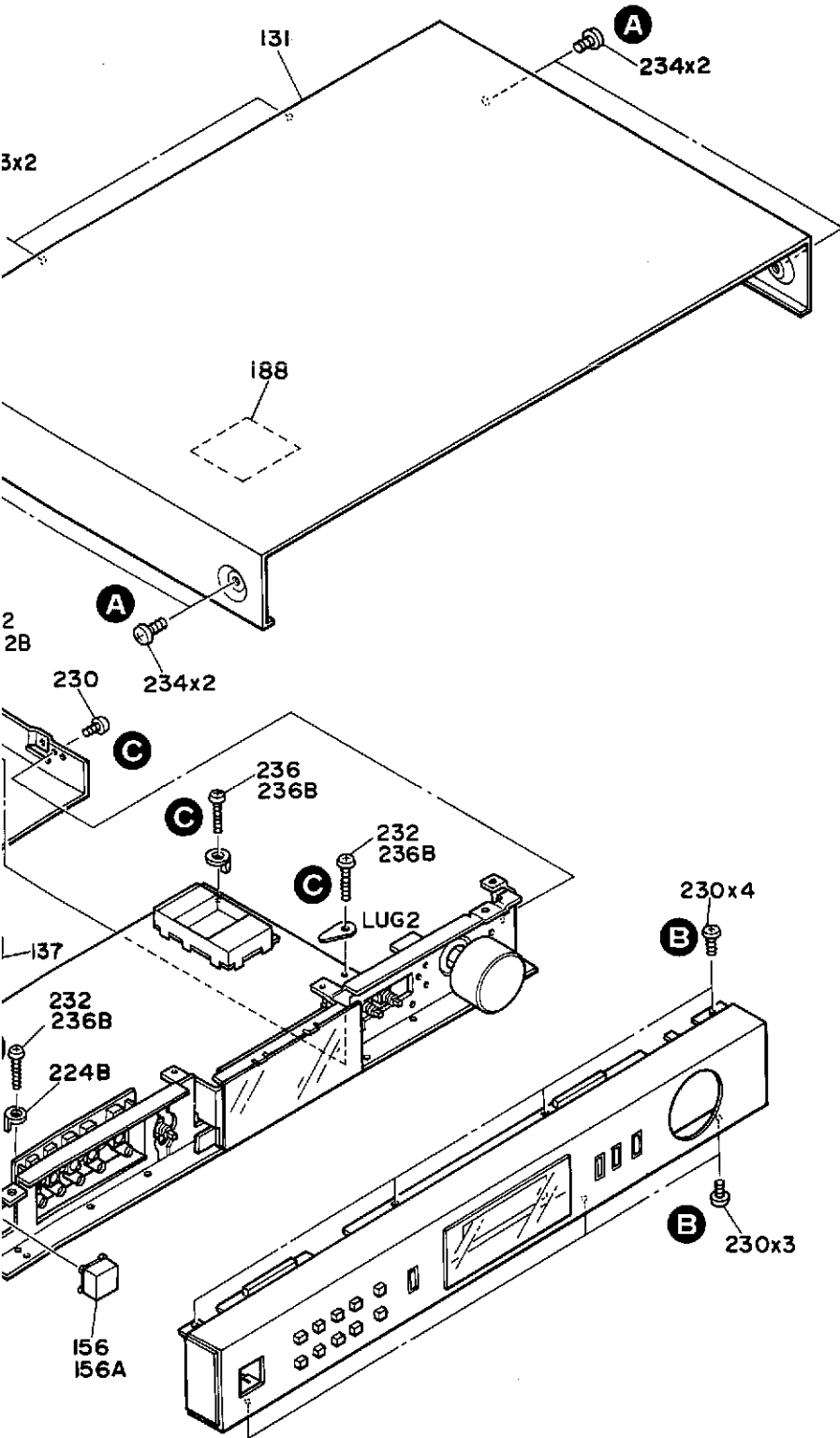

**PARTS LIST**

Ref. No.	Part No.	Description
023B	2132-7116	SPACER (G) (GB)
024B	2347-R0130122	SCREW (G) (GB)
025B	1751-14506	LABEL, FTZ (G) (GB)
125	1117-78	SERIAL LABEL
130	1756-CSA	LABEL (UA) (BK)
131	1414-02201	CABINET TOP
132	1424-23101	CABINET BOTTOM (UA) (BK)
132B	1424-23102	CABINET BOTTOM (G) (GB)
133	1424-18702	CABINET BACK (UA) (BK)
133B	1424-18802	CABINET BACK (G) (GB)
137	1319-0139	LEG
156	1660-00401	PUSH BUTTON (UA) (BK)
156A	1660-00403	PUSH BUTTON (BK) (GB)
185	2219-7984	METAL FITTG
188	2224-7091	INSULATOR
195	2240-364	HOLDER
208	2672-7018	LEVER
224	2219-7975	METAL FITTG
228	2327-R0130062	SCREW
230	2347-R0130062	SCREW
232	2347-R0130162	SCREW
233	2347-R0130064	SCREW
234	2347-R0140064	SCREW
235	2347-R0130104	SCREW
236	2347-R0130202	SCREW
237	2347-R0130082	SCREW
242	2360-7015	SPECIAL BOSS
566	2240-7208	HOLDER
LUG1	4211-4	LUG (UA) (BK)
LUG2	4211-4	LUG (G) (GB)
LUG3	4211-4	LUG (G) (GB)
ΔPI	4161-71147	CORD W/PLUG (UA) (BK)
ΔPI	4161-7256	CORD W/PLUG (G) (GB)
ΔTI	5584-701562	XFORMER, POWER (UA) (BK)
ΔTI	5584-702562	XFORMER, POWER (G) (GB)
ΔSI01	4411-102729	ROTARY SWITCH (G) (GB)
ΔSO1	4474-164	SOCKET, AC OUTLET (UA) (BK)
J1	4482-0133	PIN JACK, 2P
TM1	4214-166	TERMINAL (UA) (BK)
TM1	4214-167	TERMINAL (G) (GB)
TM2	4214-164	TERMINAL



**GENERAL UNIT**

EXPLODED VIEW (FRONT PANEL ASS'Y)

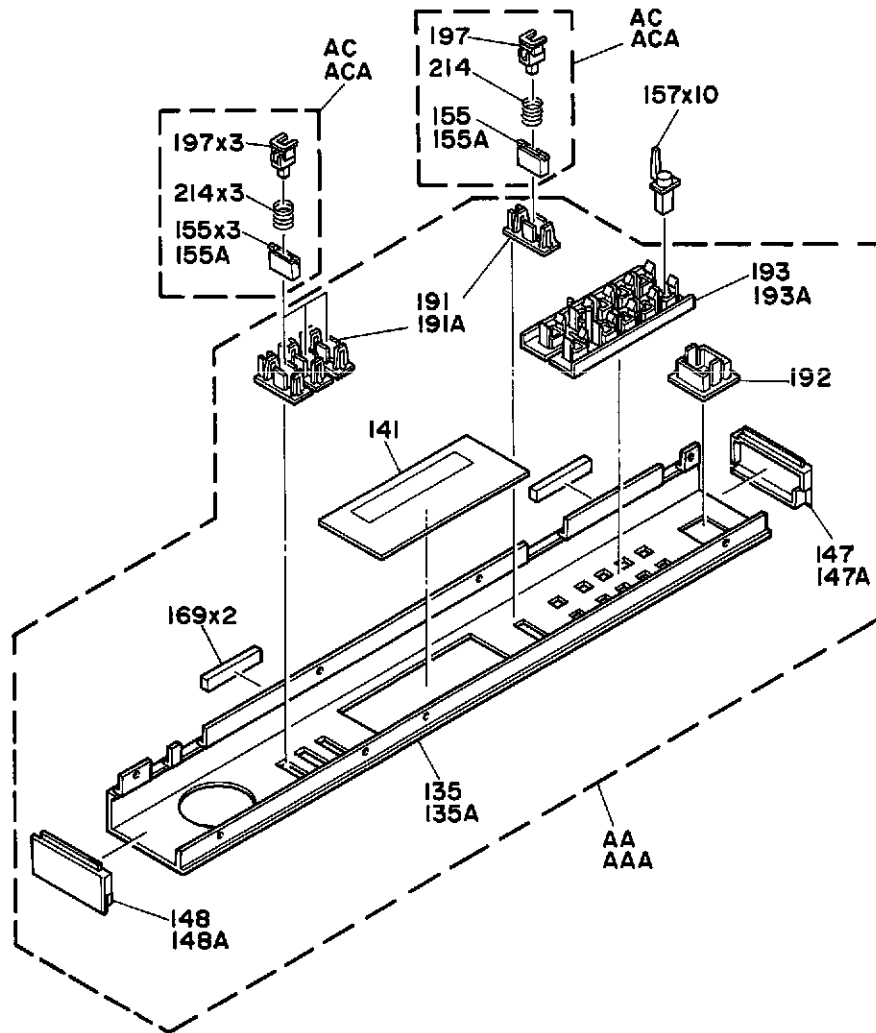

**PARTS LIST**

Ref. No.	Part No.	Description
AA	A443-TU920A	FRONT PANEL ASS'Y (U G)
AAA	A43D-TU920B	FRONT PANEL ASS'Y (BK GB)
AC	A662-TU920A	PUSH BUTTON ASS'Y
135	1443-11001	PANEL (U G)
135A	1443-11002	PANEL (BK GB)
141	1531-07003	WINDOW
147	1562-02501	FRAME L (U G)
147A	1562-02502	FRAME L (BK GB)
148	1562-02601	FRAME R (U G)
148A	1562-02602	FRAME R (BK GB)
155	1662-34201VN	PUSH BUTTON (U G)
155A	1662-34202	PUSH BUTTON (BK GB)
157	1662-26701	PUSH BUTTON
169	2112-11762	SPONGE
191	2240-7144	HOLDER (U G)
191A	2240-7275	HOLDER (BK GB)
192	2240-7209	HOLDER
193	2240-7226	HOLDER (U G)
193A	2240-7260	HOLDER (BK GB)
197	2601-7075	SHAFT
214	2651-210190	SPRING

A

B

C

D

E

# P. C. BOARDS

1

**PCB-2** Preset Switches P. C. Board

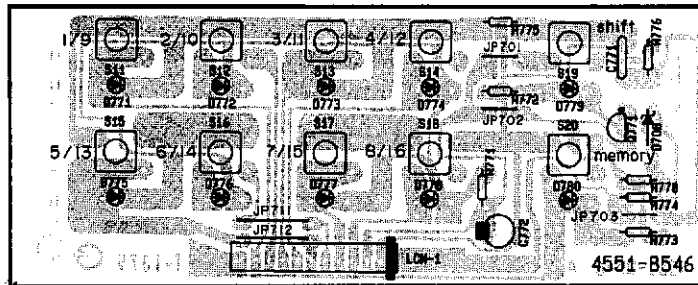

2

3

**PCB-3** Tuning Switch P. C. Board

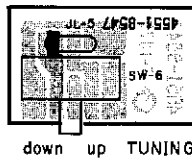

4

5

**PCB-4** Output Jack P. C. Board

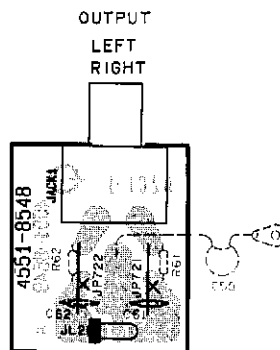

6

7

P. C. BOARDS

PCB-1 Main P. C. Board

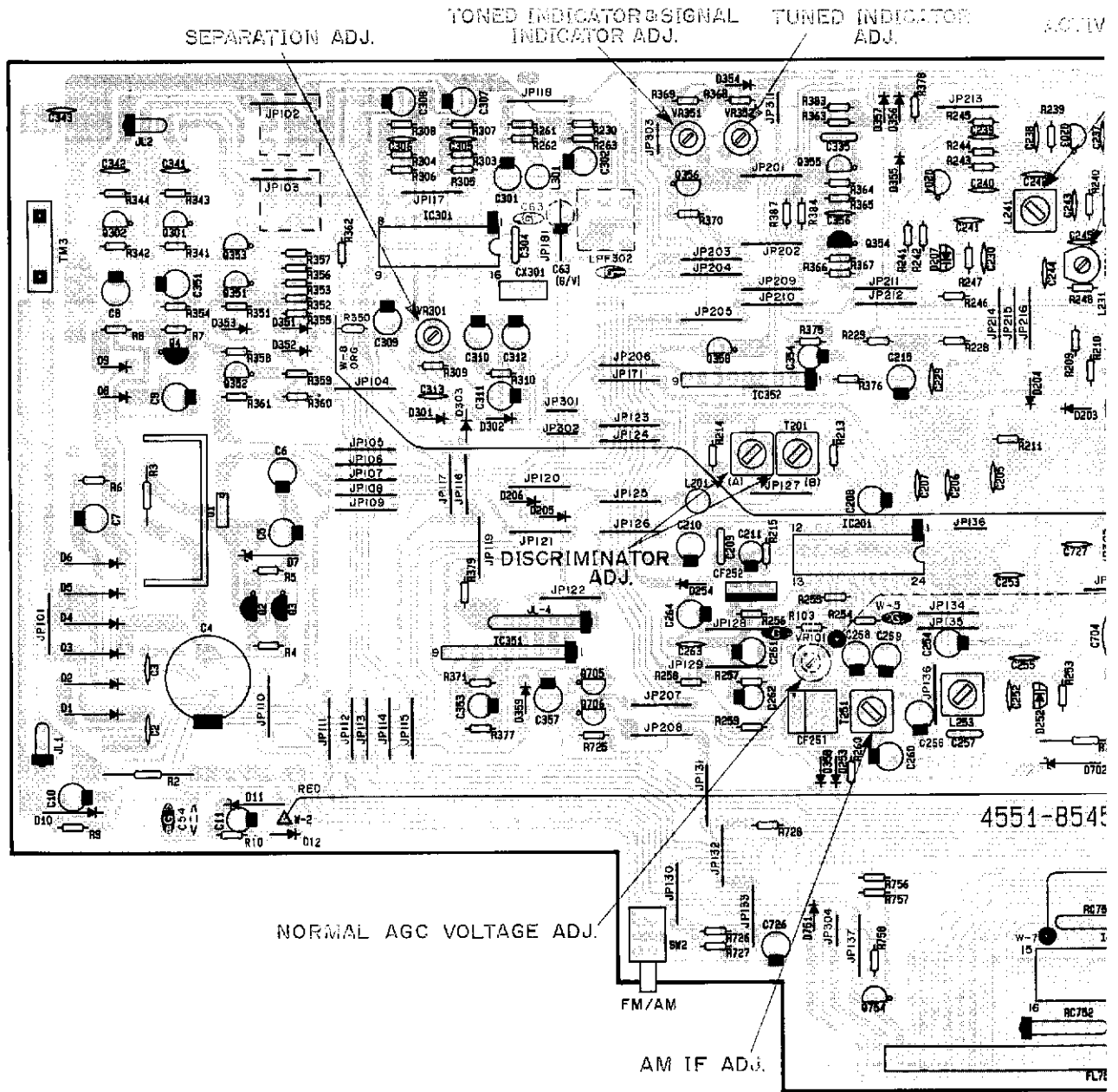

PCB-5 Power Switch P. C. Board

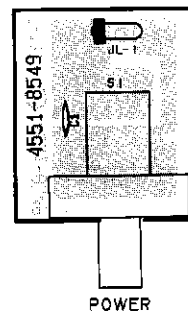

PCI



F

G

H

I

J

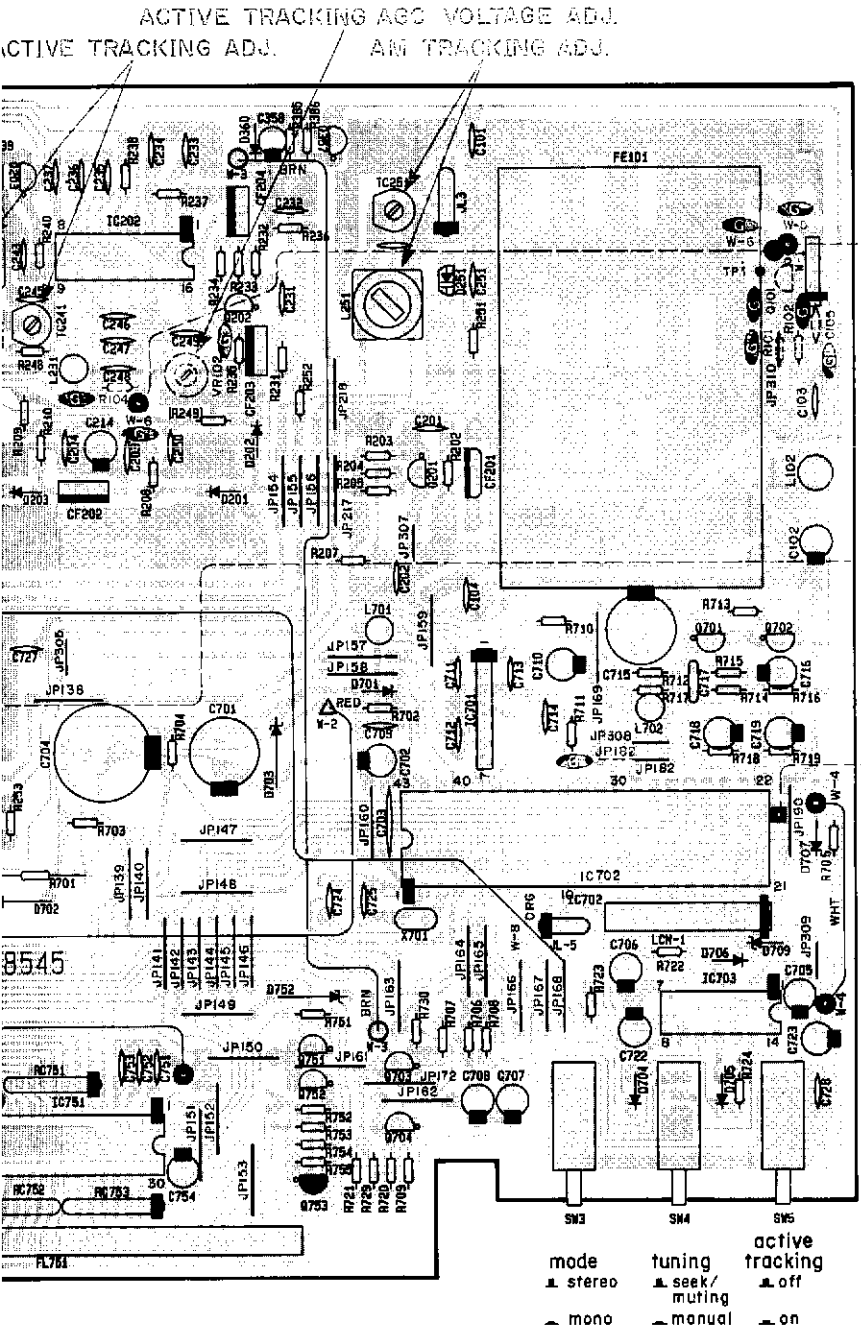

PCB-6 Antenna Terminal P. C. Board

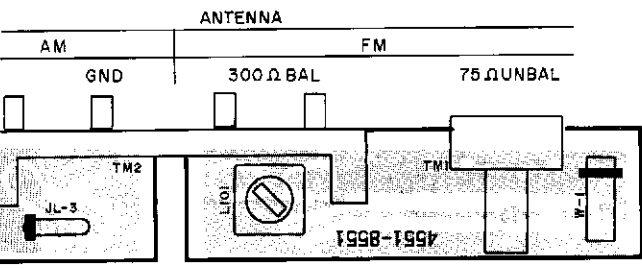

PCB-7 Indicators P. C. Board

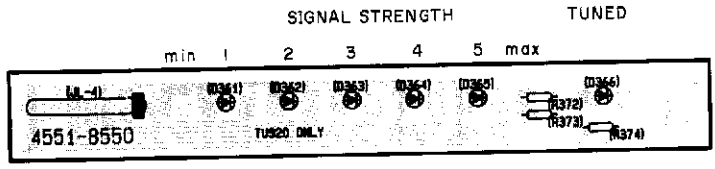

WIRING DIAGRAM

1

2

3

4

5

6

7

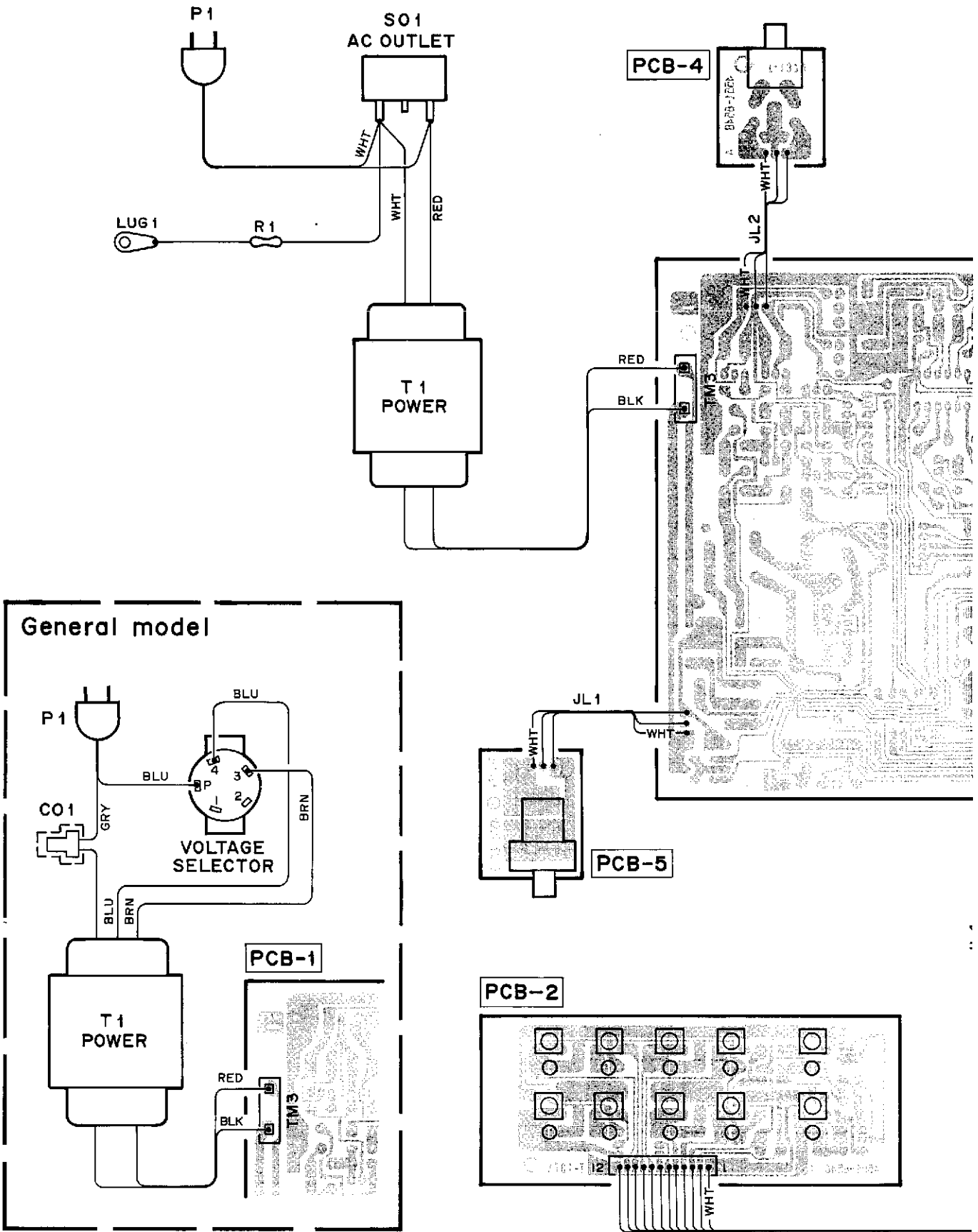

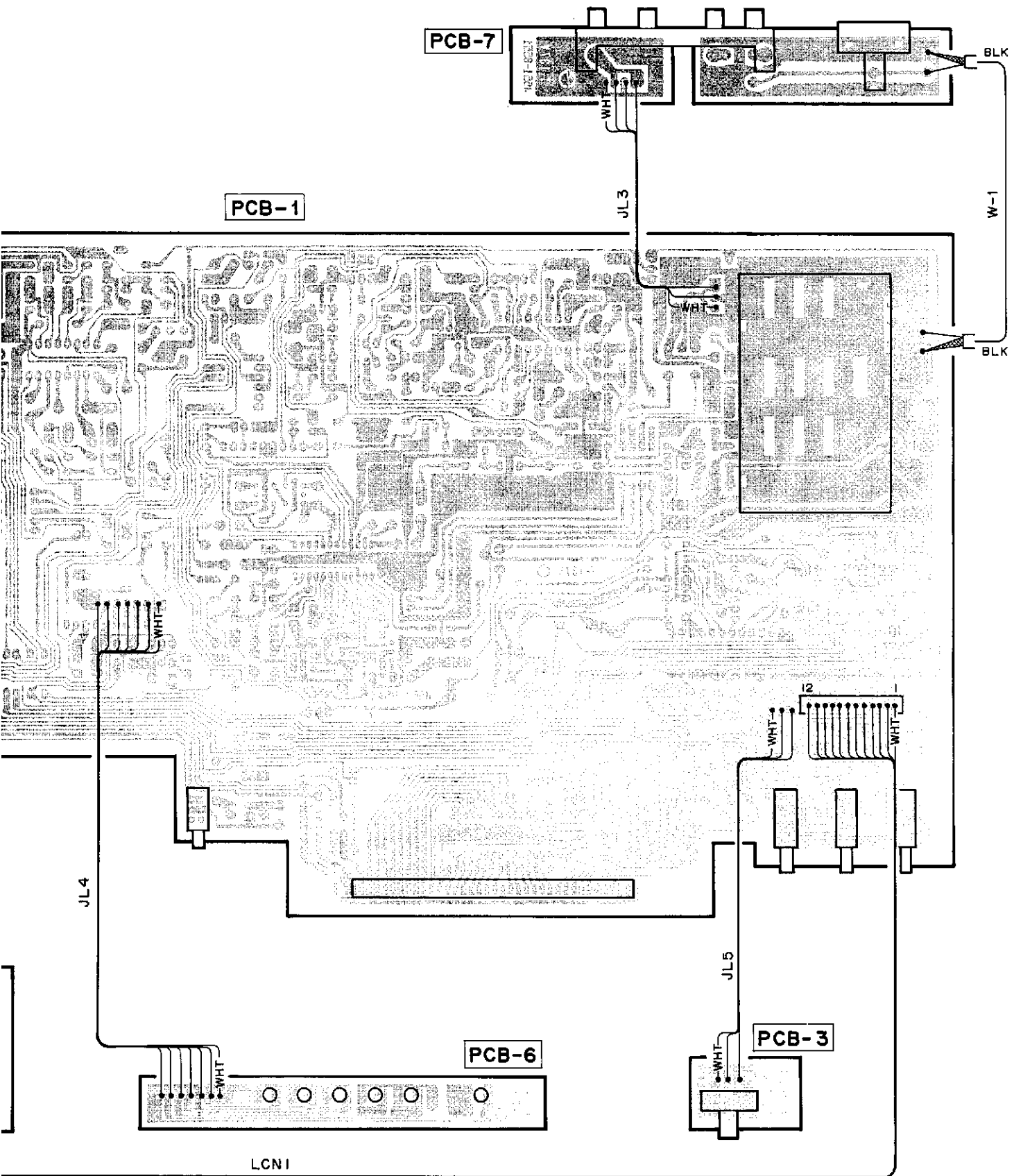

WIRE COLOR ABBREVIATIONS

Red	: RED	YEL	: Yellow
ORG	: Orange	PUP	: Purple
BLU	: Blue	PIK	: Pink
WHT	: White	GRY	: Gray
GRN	: Green	BRN	: Brown
BLK	: Black		

Ser. No.	Ref. No.	Part No.	Description	Ser. No.	Ref. No.	Part No.	Description
<b>PCB-1 MAIN P. C. BOARD</b>							
<b>CAPACITORS</b>							
786	C1	5361-473ZF	CAP, CER .047μ	637	C305	5361-471KB	CAP, CER 470p
786	C2	5361-473ZF	CAP, CER .047μ	637B	C305	5361-271KB	CAP, CER 270p
786	C3	5361-473ZF	CAP, CER .047μ	637	C306	5361-471KB	CAP, CER 470p
779	C4	5345-228D041	CAP, MINI ELE 2200μ/25V	637B	C306	5361-271KB	CAP, CER 270p
780	C5	5345-476C041	CAP, MINI ELE 47μ/16V	631	C307	5345-225F041	CAP, MINI ELE 2.2μ/50V
780	C6	5345-476C041	CAP, MINI ELE 47μ/16V	631	C308	5345-225F041	CAP, MINI ELE 2.2μ/50V
784	C7	5345-106D041	CAP, MINI ELE 10μ/25V	631	C309	5345-225F041	CAP, MINI ELE 2.2μ/50V
782	C8	5345-475D041	CAP, MINI ELE 4.7μ/25V	633	C310	5345-224F0952	CAP, MINI ELE .22μ/50V
783	C9	5345-107D041	CAP, MINI ELE 100μ/25V	634	C311	5345-106C041	CAP, MINI ELE 10μ/16V
784	C10	5345-106D041	CAP, MINI ELE 10μ/25V	632	C312	5345-474F0952	CAP, MINI ELE .47μ/50V
784	C11	5345-106D041	CAP, MINI ELE 10μ/25V	639	C313	5361-101KB	CAP, CER 100p
042B	C53	5361-223ZF	CAP, CER .022μ	679	C335	5354-104593	CAP, MYL .1μ
042B	C54	5361-223ZF	CAP, CER .022μ	636	C341	5361-472KB	CAP, CER 4700p
058B	C63	5345-226C041	CAP, MINI ELE 22μ/16V	636	C342	5361-472KB	CAP, CER 4700p
508	C101	5361-473ZF	CAP, CER .047μ	677	C343	5361-223ZF	CAP, CER .022μ
505	C102	5345-476C041	CAP, MINI ELE 47μ/16V	658	C351	5345-474F041	CAP, MINI ELE .47μ/50V
507	C103	5361-223ZF	CAP, CER .022μ	660	C353	5345-106C041	CAP, MINI ELE 10μ/16V
509	C104	5361-150KSL	CAP, CER 15p	659	C354	5345-105F041	CAP, MINI ELE 1μ/50V
053B	C105	5361-473ZF	CAP, CER .047μ	678	C356	5361-473ZF	CAP, CER .047μ
542	C201	5361-223ZF	CAP, CER .022μ	660	C357	5345-106C041	CAP, MINI ELE 10μ/16V
542	C202	5361-223ZF	CAP, CER .022μ	661	C358	5345-226C041	CAP, MINI ELE 22μ/16V
542	C203	5361-223ZF	CAP, CER .022μ	694	C701	5345-107B041	CAP, MINI ELE 100μ/10V
542	C204	5361-223ZF	CAP, CER .022μ	695	C702	5345-476B041	CAP, MINI ELE 47μ/10V
543	C205	5361-103ZF	CAP, CER .01μ	709	C703	5361-223N913	CAP, CER .022μ
542	C206	5361-223ZF	CAP, CER .022μ	693	C704	5345-228A041	CAP, MINI ELE 2200μ/6.3V
542	C207	5361-223ZF	CAP, CER .022μ	697	C705	5345-225F041	CAP, MINI ELE 2.2μ/50V
539	C208	5345-106C041	CAP, MINI ELE 10μ/16V	697	C706	5345-225F041	CAP, MINI ELE 2.2μ/50V
544	C209	5361-101KB	CAP, CER 100p	700	C707	5345-105F041	CAP, MINI ELE 1μ/50V
544B	C209	5361-271KB	CAP, CER 270p	700	C708	5345-105F041	CAP, MINI ELE 1μ/50V
539	C210	5345-106C041	CAP, MINI ELE 10μ/16V	704	C709	5361-103ZF	CAP, CER .01μ
540	C211	5345-105FD41	CAP, MINI ELE 1μ/50V	695	C710	5345-476B041	CAP, MINI ELE 47μ/10V
558	C214	5345-225F041	CAP, MINI ELE 2.2μ/50V	702	C711	5361-223ZF	CAP, CER .022μ
557	C215	5345-476C041	CAP, MINI ELE 47μ/16V	710	C712	5361-222KB	CAP, CER 2200p
601	C229	5361-223ZF	CAP, CER .022μ	703	C713	5361-220KSL	CAP, CER 22p
606	C230	5361-103ZF	CAP, CER .01μ	704	C714	5361-103ZF	CAP, CER .01μ
601	C231	5361-223ZF	CAP, CER .022μ	696	C715	5345-227C041	CAP, MINI ELE 220μ/16V
601	C232	5361-223ZF	CAP, CER .022μ	698	C716	5345-334F0951	CAP, MINI ELE .33μ/50V
601	C233	5361-223ZF	CAP, CER .022μ	708	C717	5354-473K1HM	CAP, MYL .047μ
601	C234	5361-223ZF	CAP, CER .022μ	697	C718	5345-225F041	CAP, MINI ELE 2.2μ/50V
602	C235	5361-101KB	CAP, CER 100p	697	C719	5345-225F041	CAP, MINI ELE 2.2μ/50V
602	C236	5361-101KB	CAP, CER 100p	699	C722	5345-474F041	CAP, MINI ELE .47μ/50V
603	C237	5361-473ZF	CAP, CER .047μ	699	C723	5345-474F041	CAP, MINI ELE .47μ/50V
604	C238	5361-472KB	CAP, CER 4700p	705	C724	5361-470JCH	CAP, CER 47p
601	C239	5361-223ZF	CAP, CER .022μ	705	C725	5361-470JCH	CAP, CER 47p
608	C240	5361-150JPH	CAP, CER 15p	699	C726	5345-474F041	CAP, MINI ELE .47μ/50V
606	C241	5361-103ZF	CAP, CER .01μ	702	C727	5361-223ZF	CAP, CER .022μ
607	C242	5361-180JRH	CAP, CER 18p	704	C728	5361-103ZF	CAP, CER .01μ
603	C243	5361-473ZF	CAP, CER .047μ	752	C751	5361-472KB	CAP, CER 4700p
606	C244	5361-103ZF	CAP, CER .01μ	752	C752	5361-472KB	CAP, CER 4700p
605	C245	5361-221KB	CAP, CER 220p	752	C753	5361-472KB	CAP, CER 4700p
606	C246	5361-103ZF	CAP, CER .01μ	750	C754	5345-106C041	CAP, MINI ELE 10μ/16V
601	C247	5361-223ZF	CAP, CER .022μ	<b>RESISTORS</b>			
601	C248	5361-223ZF	CAP, CER .022μ	788	R2	5171-820593	RES, MTL 1 82
606	C249	5361-103ZF	CAP, CER .01μ	793	ΔR3	5102-2R25116F	RES, FUSE 2.2
601	C250	5361-223ZF	CAP, CER .022μ	791	R4	5232-101J16P	RES, CBN 1/6P 100
577	C251	5361-473ZF	CAP, CER .047μ	790	R5	5232-223J16P	RES, CBN 1/6P 22K
580	C252	5361-220JPH	CAP, CER 22p	789	R6	5232-682J16P	RES, CBN 1/6P 6.8K
577	C253	5361-473ZF	CAP, CER .047μ	795	R7	5232-223J16P	RES, CBN 1/6P 22K
572	C254	5345-106C041	CAP, MINI ELE 10μ/16V	796	R8	5232-473J16P	RES, CBN 1/6P 47K
578	C255	5361-103ZF	CAP, CER .01μ	787	R9	5232-152J16P	RES, CBN 1/6P 1.5K
575	C257	5359-4715851	CAP, PPP 470p	794	R10	5232-102J16P	RES, CBN 1/6P 1K
571	C258	5345-475D041	CAP, MINI ELE 4.7μ/25V	059B	R63	5232-102J16P	RES, CBN 1/6P 1K
571	C259	5345-475D041	CAP, MINI ELE 4.7μ/25V	050B	R101	5232-473J16P	RES, CBN 1/6P 47K
572	C260	5345-106C041	CAP, MINI ELE 10μ/16V	051B	R102	5232-104J16P	RES, CBN 1/6P 100K
573	C261	5345-105F041	CAP, MINI ELE 1μ/50V	051B	R103	5232-563J16P	RES, CBN 1/6P 56K
572	C262	5345-106C041	CAP, MINI ELE 10μ/16V	054B	R104	5232-563J16P	RES, CBN 1/6P 56K
579	C263	5361-472KB	CAP, CER 4700p	545	R201	5232-391J16P	RES, CBN 1/6P 390
574	C264	5345-224D041	CAP, MINI ELE .22μ/25V	546	R202	5232-471J16P	RES, CBN 1/6P 470
630	C301	5345-476C041	CAP, MINI ELE 47μ/16V	547	R203	5232-154J16P	RES, CBN 1/6P 150K
629	C302	5345-226C0952	CAP, MINI ELE 22μ/16V	545	R204	5232-391J16P	RES, CBN 1/6P 390
640	C304	5354-473K1HM	CAP, MYL .047μ	548	R205	5232-101J16P	RES, CBN 1/6P 100
				551	R207	5232-102J16P	RES, CBN 1/6P 1K
				609	R208	5232-222J16P	RES, CBN 1/6P 2.2K
				610	R209	5232-331J16P	RES, CBN 1/6P 330

Ser. No.	Ref. No.	Part No.	Description	Ser. No.	Ref. No.	Part No.	Description
609	R210	5232-222J16P	RES, CBN 1/6P 2.2K	664	R366	5232-223J16P	RES, CBN 1/6P 22K
555	R211	5232-222J16P	RES, CBN 1/6P 2.2K	664	R367	5232-223J16P	RES, CBN 1/6P 22K
552	R212	5232-680J16P	RES, CBN 1/6P 68	676	R368	5232-683J16P	RES, CBN 1/6P 68K <b>UA BK</b>
553	R213	5232-103J16P	RES, CBN 1/6P 10K	676B	R368	5232-104J16P	RES, CBN 1/6P 100K <b>G GB</b>
549	R214	5232-332J16P	RES, CBN 1/6P 3.3K	675	R369	5232-563J16P	RES, CBN 1/6P 56K <b>UA BK</b>
554	R215	5232-223J16P	RES, CBN 1/6P 22K	675B	R369	5232-154J16P	RES, CBN 1/6P 150K <b>G GB</b>
554B	R215	5232-333J16P	RES, CBN 1/6P 33K <b>G GB</b>	664	R370	5232-223J16P	RES, CBN 1/6P 22K
609	R228	5232-222J16P	RES, CBN 1/6P 2.2K	663	R371	5232-103J16P	RES, CBN 1/6P 10K
620	R229	5232-332J16P	RES, CBN 1/6P 3.3K	666	R375	5232-104J16P	RES, CBN 1/6P 100K
646	R230	5232-472J16P	RES, CBN 1/6P 4.7K	666	R376	5232-104J16P	RES, CBN 1/6P 100K
610	R231	5232-331J16P	RES, CBN 1/6P 330	668	R377	5232-153J16P	RES, CBN 1/6P 15K
611	R232	5232-154J16P	RES, CBN 1/6P 150K	680	R378	5232-471J16P	RES, CBN 1/6P 470 <b>UA BK</b>
612	R233	5232-391J16P	RES, CBN 1/6P 390	680B	R378	5232-392J16P	RES, CBN 1/6P 3.9K <b>G GB</b>
613	R234	5232-101J16P	RES, CBN 1/6P 100	665	R379	5232-472J16P	RES, CBN 1/6P 4.7K
552	R235	5232-680J16P	RES, CBN 1/6P 68	674	R383	5232-222J16P	RES, CBN 1/6P 2.2K
614	R236	5232-102J16P	RES, CBN 1/6P 1K	674	R384	5232-222J16P	RES, CBN 1/6P 2.2K
615	R237	5232-471J16P	RES, CBN 1/6P 470	667	R385	5232-183J16P	RES, CBN 1/6P 18K
617	R238	5232-562J16P	RES, CBN 1/6P 5.6K	669	R386	5232-222J16P	RES, CBN 1/6P 2.2K
614	R239	5232-102J16P	RES, CBN 1/6P 1K	674	R387	5232-222J16P	RES, CBN 1/6P 2.2K
616	R240	5232-223J16P	RES, CBN 1/6P 22K	711	R701	5171-151593	RES, MTL 1 150
619	R241	5232-472J16P	RES, CBN 1/6P 4.7K	713	R702	5232-471J16P	RES, CBN 1/6P 470
618	R242	5232-104J16P	RES, CBN 1/6P 100K	714	R703	5232-103J16P	RES, CBN 1/6P 10K
610	R243	5232-331J16P	RES, CBN 1/6P 330	721	R704	5232-223J16P	RES, CBN 1/6P 22K
614	R244	5232-102J16P	RES, CBN 1/6P 1K	720	R705	5232-104J16P	RES, CBN 1/6P 100K
614	R245	5232-102J16P	RES, CBN 1/6P 1K	721	R706	5232-223J16P	RES, CBN 1/6P 22K
616	R246	5232-223J16P	RES, CBN 1/6P 22K	721	R707	5232-223J16P	RES, CBN 1/6P 22K
616	R247	5232-223J16P	RES, CBN 1/6P 22K	721	R708	5232-223J16P	RES, CBN 1/6P 22K
614	R248	5232-102J16P	RES, CBN 1/6P 1K	721	R709	5232-223J16P	RES, CBN 1/6P 22K
610	R249	5232-331J16P	RES, CBN 1/6P 330	712	R710	5232-102J16P	RES, CBN 1/6P 1K
581	R251	5232-104J16P	RES, CBN 1/6P 100K	714	R711	5232-103J16P	RES, CBN 1/6P 10K
583	R252	5232-471J16P	RES, CBN 1/6P 470	712	R712	5232-102J16P	RES, CBN 1/6P 1K
581	R253	5232-104J16P	RES, CBN 1/6P 100K	715	R713	5232-473J16P	RES, CBN 1/6P 47K
584	R254	5232-103J16P	RES, CBN 1/6P 10K	714	R714	5232-103J16P	RES, CBN 1/6P 10K
584	R255	5232-103J16P	RES, CBN 1/6P 10K	715	R715	5232-822J16P	RES, CBN 1/6P 8.2K
587	R256	5232-820J16P	RES, CBN 1/6P 82	712	R716	5232-102J16P	RES, CBN 1/6P 1K
588	R257	5232-223J16P	RES, CBN 1/6P 22K	712	R717	5232-102J16P	RES, CBN 1/6P 1K
584	R258	5232-103J16P	RES, CBN 1/6P 10K	717	R718	5232-273J16P	RES, CBN 1/6P 27K
585	R259	5232-473J16P	RES, CBN 1/6P 47K	718	R719	5232-333J16P	RES, CBN 1/6P 33K
586	R260	5232-152J16P	RES, CBN 1/6P 1.5K	722	R720	5232-472J16P	RES, CBN 1/6P 4.7K
647	R261	5232-104J16P	RES, CBN 1/6P 100K	723	R721	5232-222J16P	RES, CBN 1/6P 2.2K
647	R262	5232-104J16P	RES, CBN 1/6P 100K	720	R722	5232-104J16P	RES, CBN 1/6P 100K
646	R263	5232-472J16P	RES, CBN 1/6P 4.7K	720	R723	5232-104J16P	RES, CBN 1/6P 100K
643	R303	5232-154J16P	RES, CBN 1/6P 150K	720	R724	5232-104J16P	RES, CBN 1/6P 100K
643B	R303	5232-184J16P	RES, CBN 1/6P 180K <b>G GB</b>	731	R725	5232-153J16P	RES, CBN 1/6P 15K
643	R304	5232-154J16P	RES, CBN 1/6P 150K	720	R726	5232-104J16P	RES, CBN 1/6P 100K
643B	R304	5232-184J16P	RES, CBN 1/6P 180K <b>G GB</b>	720	R727	5232-104J16P	RES, CBN 1/6P 100K
642	R305	5232-124J16P	RES, CBN 1/6P 120K	722	R728	5232-472J16P	RES, CBN 1/6P 4.7K
642B	R305	5232-154J16P	RES, CBN 1/6P 150K <b>G GB</b>	732	R729	5232-473J16P	RES, CBN 1/6P 47K
642	R306	5232-124J16P	RES, CBN 1/6P 120K	732	R730	5232-473J16P	RES, CBN 1/6P 47K
642B	R306	5232-154J16P	RES, CBN 1/6P 150K <b>G GB</b>	755	R751	5232-223J16P	RES, CBN 1/6P 22K
644	R307	5232-332J16P	RES, CBN 1/6P 3.3K	756	R752	5232-105J16P	RES, CBN 1/6P 1M
644	R308	5232-332J16P	RES, CBN 1/6P 3.3K	754	R753	5232-473J16P	RES, CBN 1/6P 47K
645	R309	5232-103J16P	RES, CBN 1/6P 10K	754	R754	5232-473J16P	RES, CBN 1/6P 47K
648	R310	5232-472J16P	RES, CBN 1/6P 4.7K	754	R755	5232-473J16P	RES, CBN 1/6P 47K
645	R341	5232-103J16P	RES, CBN 1/6P 10K	757	R756	5232-103J16P	RES, CBN 1/6P 10K
645	R342	5232-103J16P	RES, CBN 1/6P 10K	758	R757	5232-472J16P	RES, CBN 1/6P 4.7K
645	R343	5232-103J16P	RES, CBN 1/6P 10K	758	R758	5232-472J16P	RES, CBN 1/6P 4.7K
645	R344	5232-103J16P	RES, CBN 1/6P 10K				
669	R350	5232-222J16P	RES, CBN 1/6P 2.2K			<b>INTEGRATED CIRCUITS</b>	
662	R351	5232-473J16P	RES, CBN 1/6P 47K	531	IC201	5653-LA1266	IC, LINEAR
662	R352	5232-473J16P	RES, CBN 1/6P 47K	591	IC202	5652-LA1235	IC, MONO
662	R353	5232-473J16P	RES, CBN 1/6P 47K	621	IC301	5653-LA3410	IC, LINEAR
663	R354	5232-103J16P	RES, CBN 1/6P 10K	651	IC351	5652-BA6124	IC, MONO
662	R355	5232-473J16P	RES, CBN 1/6P 47K	652	IC352	5652-BA695	IC, MONO
664	R356	5232-223J16P	RES, CBN 1/6P 22K	681	IC701	5654-TD6104P	IC, DIGITAL
662	R357	5232-473J16P	RES, CBN 1/6P 47K	682	IC702	5654-TC9147BP	IC, DIGITAL
672	R358	5232-473J16P	RES, CBN 1/6P 47K	683	IC703	5654-TC4001BP	IC, DIGITAL
662	R359	5232-473J16P	RES, CBN 1/6P 47K	741	IC751	5654-TD6301AN	IC, DIGITAL
662	R360	5232-473J16P	RES, CBN 1/6P 47K			<b>TRANSISTORS</b>	
672	R361	5232-473J16P	RES, CBN 1/6P 47K	771	Q1	5614-1666(R)	XISTOR, NPN A
673	R362	5232-100J16P	RES, CBN 1/6P 10	772	Q2	5611-1115(F)or(E)	XISTOR, PNP R
674	R363	5232-222J16P	RES, CBN 1/6P 2.2K	772	Q3	5611-1115(F)or(E)	XISTOR, PNP R
665	R364	5232-472J16P	RES, CBN 1/6P 4.7K	772	Q4	5611-1115(F)or(E)	XISTOR, PNP R
664	R365	5232-223J16P	RES, CBN 1/6P 22K	052B	Q101	5613-2603(F)or(E)	XISTOR, NPN R <b>G GB</b>



Ser. No.	Ref. No.	Part No.	Description
532	Q201	5613-2058(N)	XISTOR, NPN R
592	Q202	5613-2058(N)	XISTOR, NPN R
593	Q203	5613-2603(F)	XISTOR, NPN R
592	Q204	5613-2058(N)	XISTOR, NPN R
622	Q301	5613-2878(B)	XISTOR, NPN R
622	Q302	5613-2878(B)	XISTOR, NPN R
654	Q351	5613-2603(F)or(E)	XISTOR, NPN R
654	Q352	5613-2603(F)or(E)	XISTOR, NPN R
654	Q353	5613-2603(F)or(E)	XISTOR, NPN R
655	Q354	5611-1115(F)or(E)	XISTOR, PNP R
654	Q355	5613-2603(F)or(E)	XISTOR, NPN R
656	Q356	5613-RN1203	XISTOR, NPN R
654	Q357	5613-2603(F)or(E)	XISTOR, NPN R
656	Q358	5613-RN1203	XISTOR, NPN R
689	Q701	5613-2240(BL)	XISTOR, NPN R
685	Q702	5613-2603(F)	XISTOR, NPN R
685	Q703	5613-2603(F)	XISTOR, NPN R
685	Q704	5613-2603(F)	XISTOR, NPN R
684	Q705	5613-RN1203	XISTOR, NPN R
684	Q706	5613-RN1203	XISTOR, NPN R
747	Q751	5613-RN1203	XISTOR, NPN R
746	Q752	5613-2603(F)or(E)	XISTOR, PNP R
748	Q753	5611-1115(F)or(E)	XISTOR, PNP R
747	Q754	5613-RN1203	XISTOR, NPN R

**DIODES**

774	ΔD1	5632-S5277B-6	DIODE, RECT
774	ΔD2	5632-S5277B-6	DIODE, RECT
774	ΔD3	5632-S5277B-6	DIODE, RECT
774	ΔD4	5632-S5277B-6	DIODE, RECT
774	ΔD5	5632-S5277B-6	DIODE, RECT
774	ΔD6	5632-S5277B-6	DIODE, RECT
776	D7	5635-HZ15-1L	DIODE, ZENER
775	D8	5631-ISS133	DIODE, DET
775	D9	5631-ISS133	DIODE, DET
774	D10	5632-S5277B-6	DIODE, RECT
777	D11	5635-HZ6B1L	DIODE, ZENER
775	D12	5631-ISS133	DIODE, DET
598	D201	5631-ISS133	DIODE, DET
598	D202	5631-ISS133	DIODE, DET
598	D203	5631-ISS133	DIODE, DET
598	D204	5631-ISS133	DIODE, DET
556	D205	5631-ISS133	DIODE, DET
556	D206	5631-ISS133	DIODE, DET
599	D207	5633-ISV103	DIODE, CAP
561	D251	5633-ISV149	DIODE, CAP
561	D252	5633-ISV149	DIODE, CAP
562	D253	5631-ISS133	DIODE, DET
562	D254	5631-ISS133	DIODE, DET
623	D301	5631-ISS133	DIODE, DET
623	D302	5631-ISS133	DIODE, DET
657	D351	5631-ISS133	DIODE, DET
657	D352	5631-ISS133	DIODE, DET
657	D353	5631-ISS133	DIODE, DET
657	D354	5631-ISS133	DIODE, DET
657	D355	5631-ISS133	DIODE, DET
657	D356	5631-ISS133	DIODE, DET
657	D357	5631-ISS133	DIODE, DET
657	D358	5631-ISS133	DIODE, DET
657	D359	5631-ISS133	DIODE, DET
657	D360	5631-ISS133	DIODE, DET
688	D701	5631-ISS133	DIODE, DET
686	D702	5635-HZ9A1L	DIODE, ZENER
687	D703	5635-HZ6B1L	DIODE, ZENER
688	D704	5631-ISS133	DIODE, DET
688	D705	5631-ISS133	DIODE, DET
688	D706	5631-ISS133	DIODE, DET
688	D707	5631-ISS133	DIODE, DET
734	D709	5635-RD4R7EB2	DIODE, ZENER
742	D751	5631-ISS133	DIODE, DET
743	D752	5635-HZ11A2L	DIODE, ZENER

Ser. No.	Ref. No.	Part No.	Description
<b>COILS</b>			
503	L102	5995-2R2J107	COIL W/CORE
537	L201	5995-2R2J107	COIL W/CORE
600	L231	5995-2R2J107	COIL W/CORE
596	L241	5922-00315	OSC COIL, 7
570	L251	5933-00101	COIL CASE, 10
564	L253	5922-00215	OSC COIL, 7
627	L301	5995-2R2J107	COIL W/CORE
691	L701	5995-2R2J107	COIL W/CORE
691	L702	5995-2R2J107	COIL W/CORE

**TRANSFORMERS**

536	T201	5572-10201	DISCRI 7
565	T251	5552-00712	IFT, AM 7

**CONTROLS**

055B	VR101	5101-10401937	RES, SEMI FIX 100K	(G) (GB)
055B	VR102	5101-10401937	RES, SEMI FIX 100K	(G) (GB)
626	VR301	5101-10401937	RES, SEMI FIX 100K	
534	VR351	5101-50301937	RES, SEMI FIX 50K	(LA) (BK)
534B	VR351	5101-10401937	RES, SEMI FIX 100K	(G) (GB)
594	VR352	5101-50301937	RES, SEMI FIX 50K	(UA) (BK)
594B	VR352	5101-10401937	RES, SEMI FIX 100K	(G) (GB)

**MISCELLANEOUS**

814	S2	4431-S0602102	SWITCH, PUSH	
815	S3	4431-S0601102	SWITCH, PUSH	
815	S4	4431-S0601102	SWITCH, PUSH	
815	S5	4431-S0601102	SWITCH, PUSH	
690	X701	5691-00720022	XTAL, OSC	
535	CF201	5671-7120A	FILTER, CER S	
535B	CF201	5673-718A	FILTER ASST	(G) (GB)
535	CF202	5671-7120A	FILTER, CER S	
535B	CF202	5673-718A	FILTER ASST	(G) (GB)
595	CF203	5671-7142A	FILTER, CER S	
595	CF204	5671-7142A	FILTER, CER S	
567	CF251	5671-0159	FILTER, CER S	
568	CF252	5671-7137C	FILTER, CER S	
625	CX301	5693-CSB456F1	OSC, CER	
501	FE101	6114-00101	FM TUNER	
501B	FE101	6114-00201	FM TUNER	(G) (GB)
801	FL751	5722-14	TUBE DISPLAY	
744	RC751	5212-473J0703	R COMPOSITE	
744	RC752	5212-473J0703	R COMPOSITE	
744	RC753	5212-473J0703	R COMPOSITE	
597	TC241	5371-93	TRIMMER, IP	
569	TC251	5371-93	TRIMMER, IP	
823	TM3	4214-11033	TERMINAL	
831	LCN1	4163-01101012	CONNECTR W/W	
044B	LPF302	5214-86	LC COMPOSITE	(G) (GB)

**PCB-2 PRESET SWITCHES P. C. BOARD****CAPACITORS**

726	C771	5361-102KB	CAP, CER 1000p
727	C772	5345-106C041	CAP, MINI ELE 10μ/16V

**RESISTORS**

728	R771	5232-221J16P	RES, CBN 1/6P 220
728	R772	5232-221J16P	RES, CBN 1/6P 220
728	R773	5232-221J16P	RES, CBN 1/6P 220
730	R774	5232-472J16P	RES, CBN 1/6P 4.7K
736	R775	5232-223J16P	RES, CBN 1/6P 22K
737	R776	5232-333J16P	RES, CBN 1/6P 33K
733	R778	5232-103J16P	RES, CBN 1/6P 10K

**TRANSISTORS**

724	Q771	5613-2240(BL)	XISTOR, NPN R
-----	------	---------------	---------------

**DIODES**

725	D708	5635-RD4R7EB2	DIODE, ZENER
809	D771	5637-GL5NG40	LED

Ser. No.	Ref. No.	Part No.	Description
809	D772	5637-GL5NG40	LED
809	D773	5637-GL5NG40	LED
809	D774	5637-GL5NG40	LED
809	D775	5637-GL5NG40	LED
809	D776	5637-GL5NG40	LED
809	D777	5637-GL5NG40	LED
809	D778	5637-GL5NG40	LED
809	D779	5637-GL5NG40	LED
809	D780	5637-GL5NG40	LED
<b>MISCELLANEOUS</b>			
813	S11	4431-A017169	SWITCH, PUSH
813	S12	4431-A017169	SWITCH, PUSH
813	S13	4431-A017169	SWITCH, PUSH
813	S14	4431-A017169	SWITCH, PUSH
813	S15	4431-A017169	SWITCH, PUSH
813	S16	4431-A017169	SWITCH, PUSH
813	S17	4431-A017169	SWITCH, PUSH
813	S18	4431-A017169	SWITCH, PUSH
813	S19	4431-A017169	SWITCH, PUSH
813	S20	4431-A017169	SWITCH, PUSH

**PCB-3 TUNING SWITCH P. C. BOARD**

816	S6	4411-1D27110	SWITCH, ROTRY
837	JL5	4242-R0103201	JUMPER LEAD

**PCB-4 OUTPUT JACK P. C. BOARD**

<b>CAPACITORS</b>			
041B	C55	5361-223ZF	CAP, CER .022μ
049B	C61	5361-101KB	CAP, CER 100p
049B	C62	5361-101KB	CAP, CER 100p
<b>RESISTORS</b>			
048B	R61	5232-102J16P	RES, CBN 1/6P 1K
048B	R62	5232-102J16P	RES, CBN 1/6P 1K
<b>MISCELLANEOUS</b>			
827	J1	4482-0133	PIN JACK, 2P
834	JL2	4242-R0103201	JUMPER LEAD

**PCB-5 POWER SWITCH P. C. BOARD**

812	ΔS1	4431-A02725	SWITCH, PUSH
833	JL1	4242-R0103201	JUMPER LEAD

**PCB-6 ANTENNA TERMINAL P. C. BOARD**

511	L101	5943-00136	COIL, BBN, 10
835	JL3	4242-R0104201	JUMPER LEAD
820	TM1	4214-166	TERMINAL
820B	TM1	4214-167	TERMINAL
821	TM2	4214-164	TERMINAL

**PCB-7 INDICATORS P. C. BOARD**

<b>RESISTORS</b>			
670	R372	5232-122J16P	RES, CBN 1/6P 1.2K
670	R373	5232-122J16P	RES, CBN 1/6P 1.2K
671	R374	5232-681J16P	RES, CBN 1/6P 680
<b>DIODES</b>			
810	D361	5637-TLG121	LED
810	D362	5637-TLG121	LED
810	D363	5637-TLG121	LED
810	D364	5637-TLG121	LED
810	D365	5637-TLG121	LED
810	D366	5637-TLG121	LED
<b>MISCELLANEOUS</b>			
836	JL4	4242-R0107181	JUMPER LEAD

**ABBREVIATIONS IN PARTS LIST**

<b>CAPACITORS</b>		<b>RESISTORS</b>	
CAP, MINI ELE	: Electrolytic	RES, CBN 1/6P	: Carbon 1/6W
CAP, CER	: Ceramic	RES, FUSE	: Fuse
CAP, PPP	: Polypropylene	RES, CEM 5P	: Cement 5W
CAP, MYL	: Mylar	RES, MTL 1P	: Metal 1W
CAP, MCA	: Mica		2.2K : 2.2kΩ
CAP, MINI BP	: Bipolar		220 : 220Ω
CAP, ELE BP	: Electrolytic Bipolar	<b>TRANSISTORS</b>	
CAP, STY	: Polystyrene Film	XISTOR	: Transistor
CAP, SPE	: Special	FET	: Field Effect Transistor
CAP, TAN	: Tantalum	<b>CONTROLS</b>	
	470μ : 470μF	RES, V CBN	: Variable Carbon Resistor
	6800p : 6800pF	RES, SEMI FIX	: Semi-fixed Resistor
	.047μ : 0.047μF		

**NOTE**



SAFETY RELATED COMPONENT. USE ONLY EXACT REPLACEMENT PART AS SPECIFIED.

**CHASSIS MISCELLANEOUS**

804	ΔPI	4161-71147	CORD W/PLUG
804B	ΔPI	4161-7256	CORD W/PLUG
807	ΔTI	5584-701562	XFORMER, POWER
807B	ΔTI	5584-702562	XFORMER, POWER
792	ΔRI	5135-335J50P	RES, CBN 1/2P 3.3M
045B	ΔS101	4411-102729	ROTARY SWITCH
046B	ΔC01	4443-712	CONNECTOR
818	LUG1	4211-4	LUG
043B	LUG2	4211-4	LUG
043B	LUG3	4211-4	LUG
825	ΔS01	4474-164	SOCKET, AC OUTLET
563		5911-235	AM LOOP ANT
803		4161-71184	CORD W/PLUG, CONNECT
805		1397-6	T FEEDER ANT

**PACKAGE PARTS LIST**

026B	1119-0135	ATTACH SHEET, FTZ
111	1221-827147	CARTON BOX
111A	1221-847147	CARTON BOX
113	1222-7227	CUSHION
114	1222-7224	CUSHION
116	1223-R0120055	SOFT SHEET
117	1241-R0123350	POLYETHYLENE BAG
118	1241-R0155500	POLYETHYLENE BAG
119	1241-R0115300	POLYETHYLENE BAG
120	1111-J30275	OWNER GUIDE
120B	1111-J30276	OWNER GUIDE
121	1111-J90195	OWNER GUIDE
122	1113-717004	OWNER CARD
122B	1111-J30235	OWNER CARD, ADDENDUM SHEET
123	1119-047	ATTACH SHEET

IC BLOCK DIAGRAM

LA1266 : IC201 FM/AM IF

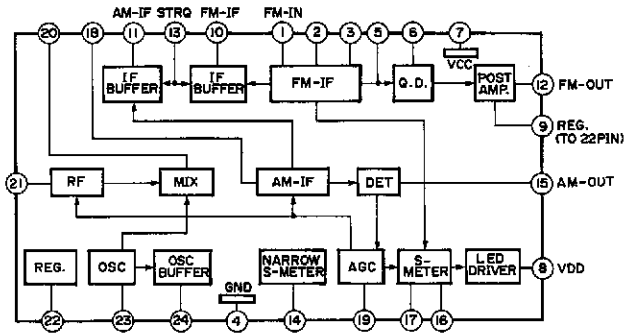

LA1235 : IC202 FM IF

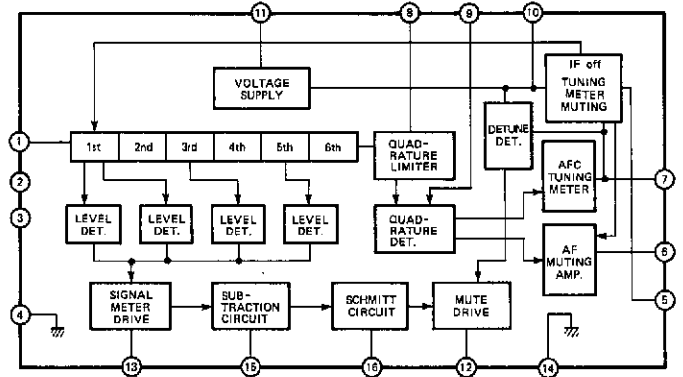

LA3410 : IC301 PLL MPX

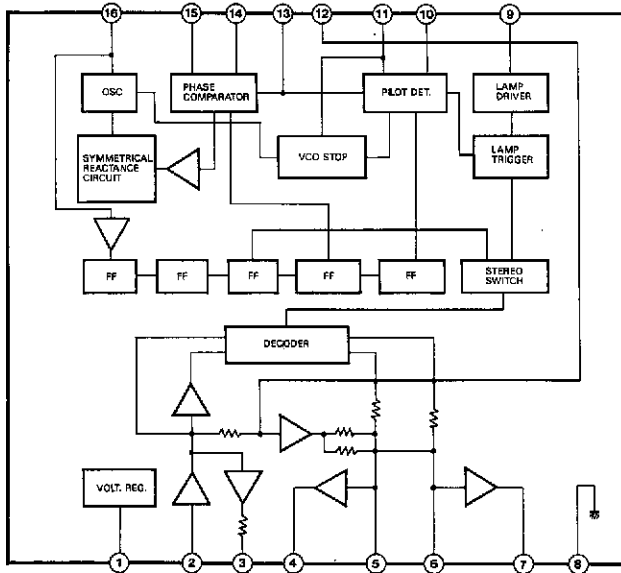

BA6124 : IC351 LEVEL METER DRIVER

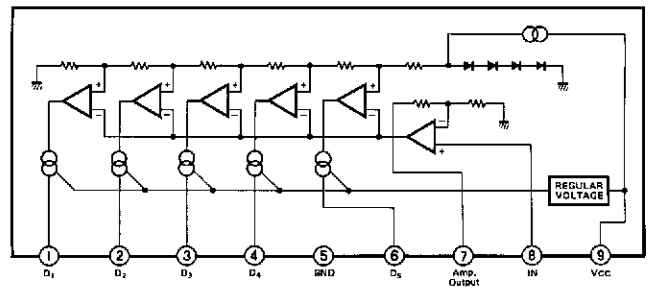

BA695 : IC352 LEVEL METER DRIVER

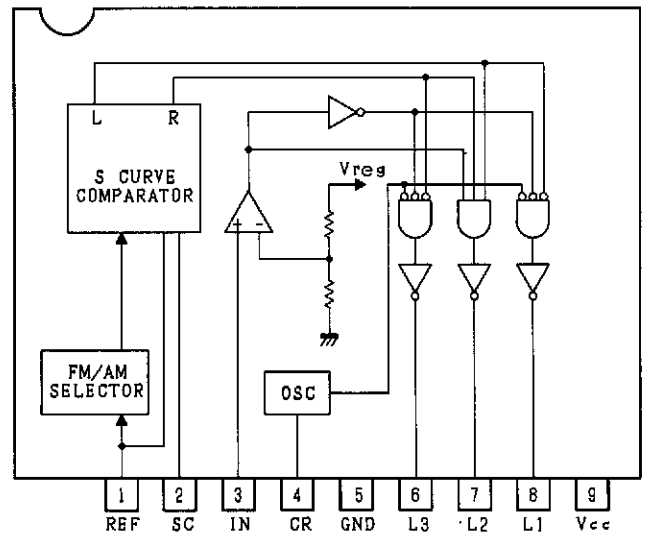

TD6104P : IC701 FM ECL PRE-SCALLER

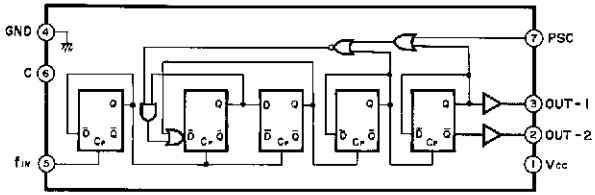

TC9147BP : IC702 DIGITAL TUNING SYSTEM LSI

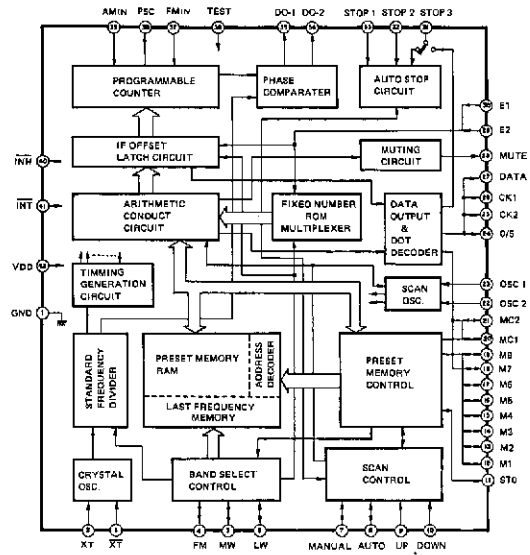

TC4001BP : IC703 QUAND 2 INPUT NOR GATE

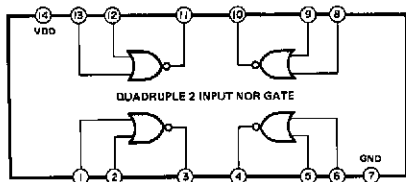

TD6301AN : IC751 LCD DRIVER

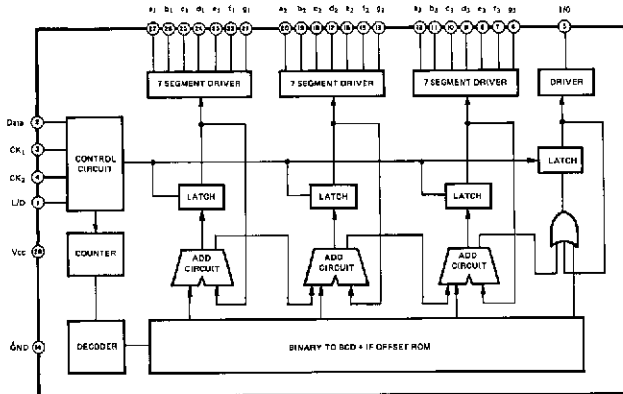

# SCHEMATIC DIAGRAM

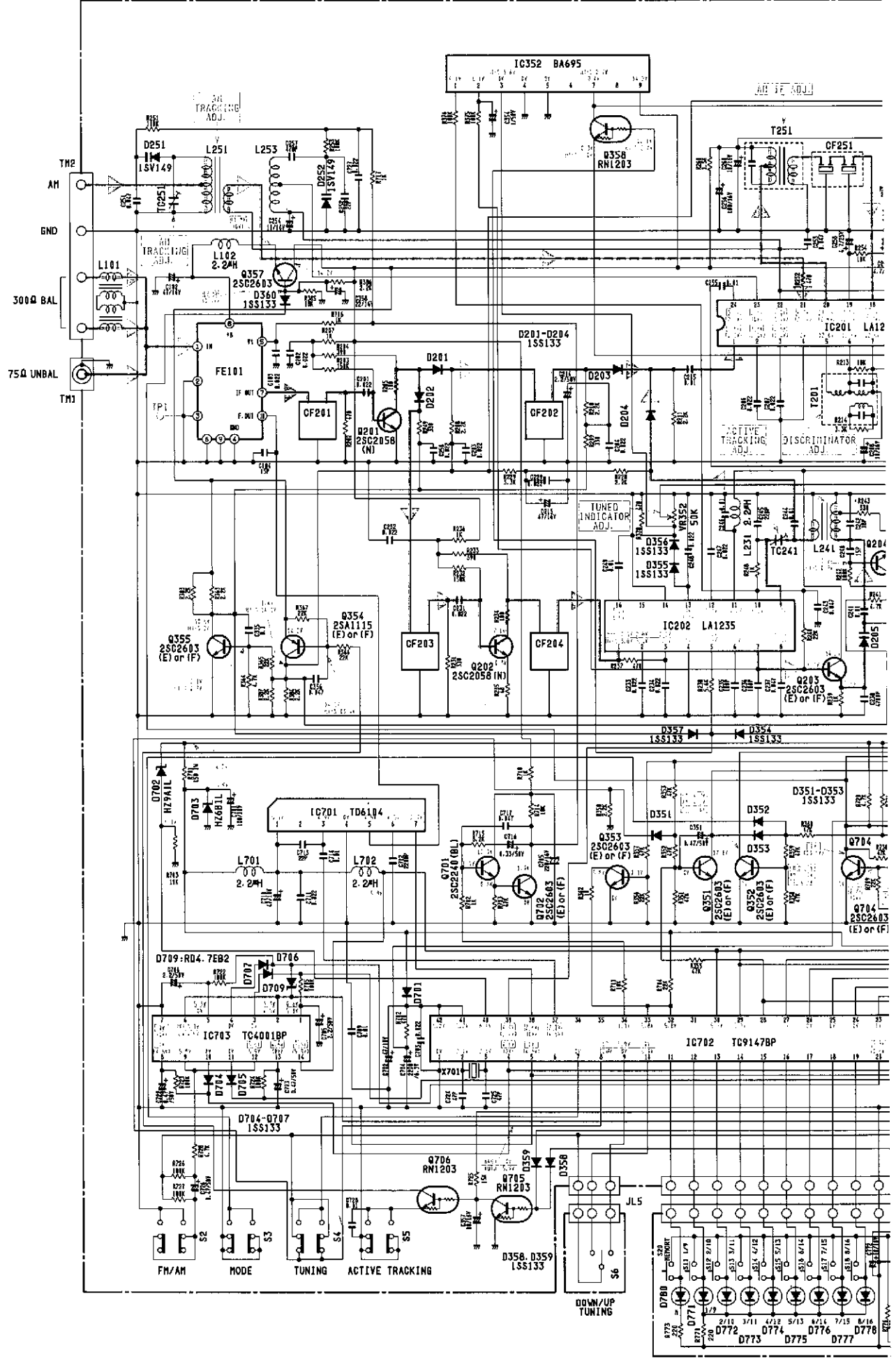

F

G

H

I

J

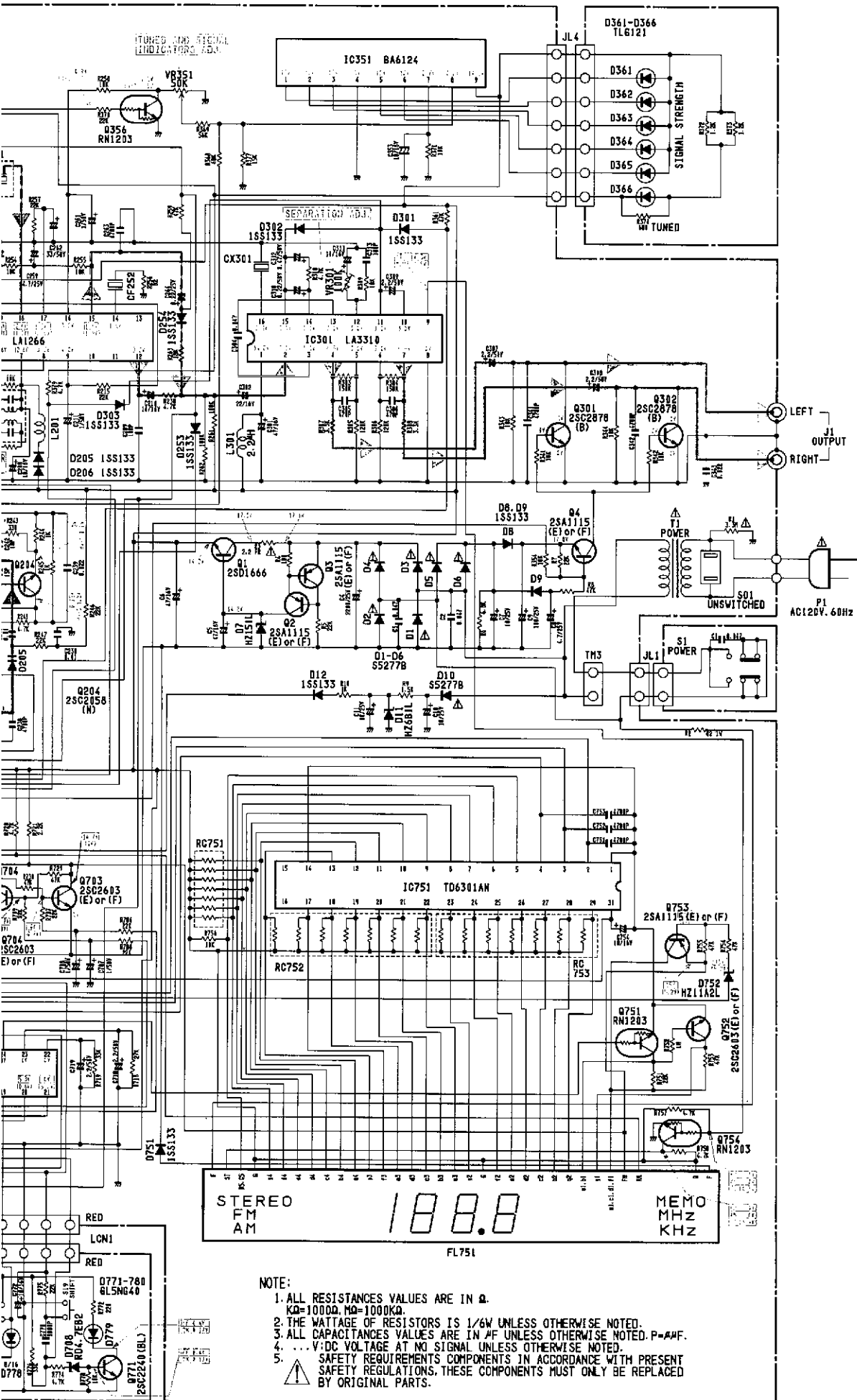

- NOTE:
1. ALL RESISTANCES VALUES ARE IN  $\Omega$ .  
K $\Omega$ =1000 $\Omega$ , M $\Omega$ =1000K $\Omega$ .
  2. THE WATTAGE OF RESISTORS IS 1/2W UNLESS OTHERWISE NOTED.
  3. ALL CAPACITANCES VALUES ARE IN  $\mu$ F UNLESS OTHERWISE NOTED. P= $\mu$ MF.
  4. ... V:DC VOLTAGE AT NO SIGNAL UNLESS OTHERWISE NOTED.
  5. SAFETY REQUIREMENTS COMPONENTS IN ACCORDANCE WITH PRESENT SAFETY REGULATIONS. THESE COMPONENTS MUST ONLY BE REPLACED BY ORIGINAL PARTS.

**SCHEMATIC DIAGRAM (For General model)**

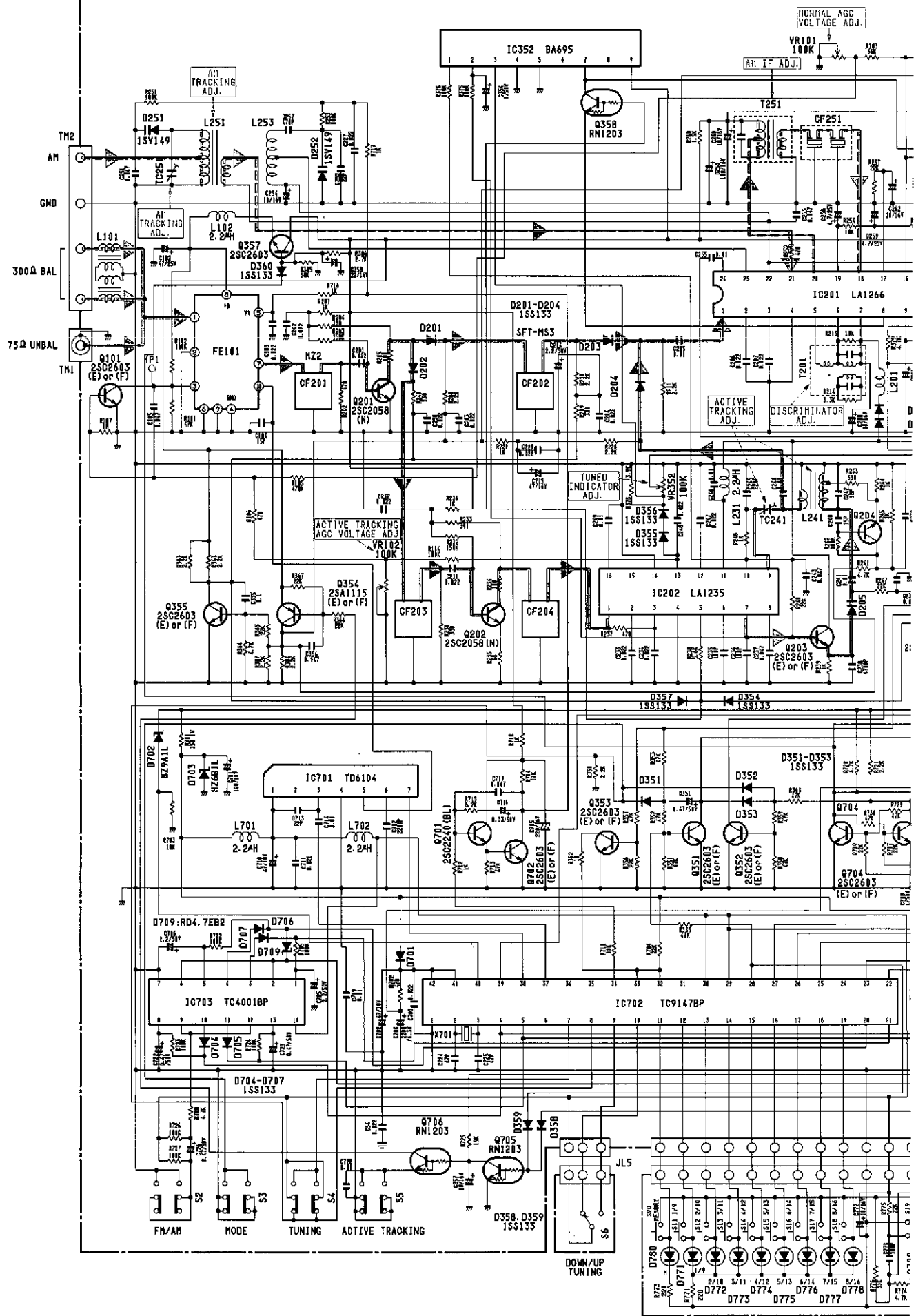

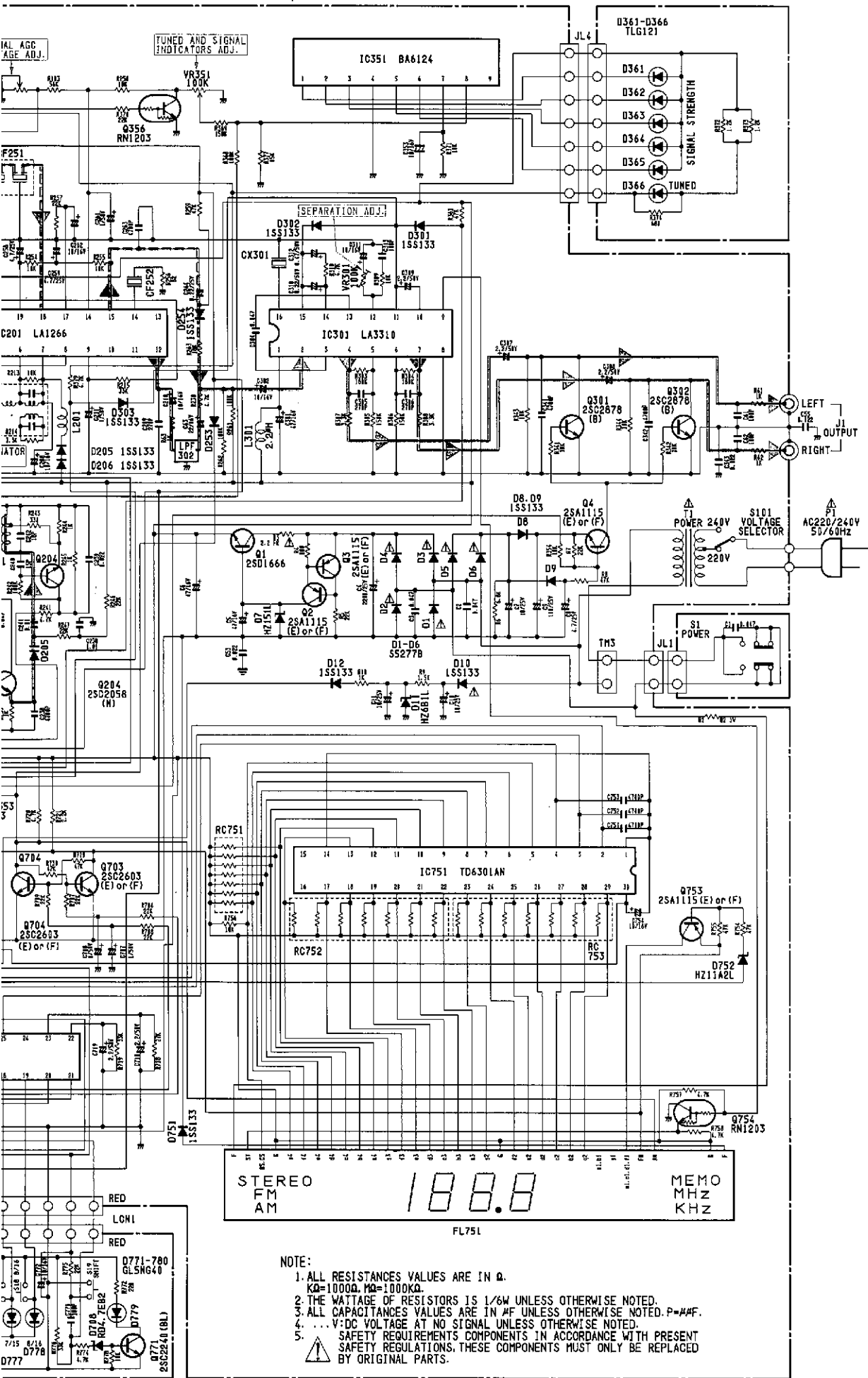

NOTE:

1. ALL RESISTANCES VALUES ARE IN  $\Omega$ .  
K $\Omega$ =1000 $\Omega$ , M $\Omega$ =1000K $\Omega$ .
2. THE WATTAGE OF RESISTORS IS 1/8W UNLESS OTHERWISE NOTED.
3. ALL CAPACITANCES VALUES ARE IN  $\mu$ F UNLESS OTHERWISE NOTED. P= $\mu$ F.
4. ...V:DC VOLTAGE AT NO SIGNAL UNLESS OTHERWISE NOTED.
5. SAFETY REQUIREMENTS COMPONENTS IN ACCORDANCE WITH PRESENT SAFETY REGULATIONS. THESE COMPONENTS MUST ONLY BE REPLACED BY ORIGINAL PARTS.