

# The Harman Kardon Model TU9600 ACTIVE TRACKING TUNER

Manual 155A

## Technical Manual

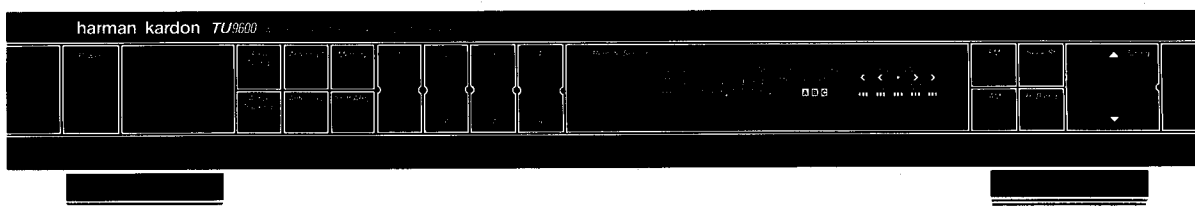

The following marks found in the parts list of this manual identify the models as follows.

- Ⓚ : North America area model Black version
- Ⓛ : International model Black version
- Ⓜ : Australia model Black version

**harman/kardon**

240 Crossways Park West, Woodbury, N.Y. 11797  
1112-3152155A8 P-079007 2000 Printed in Japan

**CONTENTS**

SPECIFICATIONS ..... 2  
 LEAKAGE TEST ..... 2  
 CONTROLS & DISPLAYS ..... 3  
 DISASSEMBLY PROCEDURES ..... 4  
 POWER CORD REPLACEMENT ..... 4  
 ALIGNMENT PROCEDURES ..... 5  
 CIRCUIT DESCRIPTION ..... 7  
 BLOCK DIAGRAM ..... 7

GENERAL UNIT  
 (EXPLODED VIEW, PARTS LIST) ..... 8  
 WIRING DIAGRAM ..... 10  
 P.C. BOARDS ..... 11  
 ELECTRICAL PARTS LIST ..... 13  
 IC BLOCK DIAGRAM ..... 18  
 IC TERMINAL FUNCTIONS ..... 21  
 SCHEMATIC DIAGRAM ..... 26

**SPECIFICATIONS**

● **FM SECTION**

	Nominal	Limit
Tuning Range	87.5 ~ 108.0MHz	
Stereo	50dB Quieting Sensitivity	
Usable Sensitivity	37.2dBf	≥ 41(48)dBf
Mono	11.7dBf	≥ 15(17)dBf
Mono for active tracking	13.2dBf	
Image Ratio	47dB	≥ 40(90)dB
IF Rejection	85dB	≥ 75(100)dB
Spurious Response Rejection	96dB	
Capture Ratio at 65dBf	1.2dB	≥ 2dB
Alternate Channel Selectivity	45dB	≥ 40dB
for active tracking	78dB	≥ 70dB
AM Rejection	60dB	≥ 45dB
Signal to Noise Ratio		
Mono	83dB	≥ 77(71)dB
Stereo	75dB	≥ 69(63)dB
Total Harmonic Distortion (65dBf 1kHz Input)		
Mono	0.09%	≥ 0.3%
Mono for active tracking	0.2%	≥ 0.5%
Stereo	0.07%	≥ 0.5%
Stereo for active tracking	0.1%	≥ 0.6%
Stereo Separation at 1kHz	58dB	≥ 40(35)dB

This figures in parenthesis ( ) in the FM section are specifications for the International model.

● **AM SECTION**

	Nominal	Limit
Tuning Range		
North America area model	520 ~ 1,620kHz	
International and Australia models	531 ~ 1,602kHz	
Usable Sensitivity	17 μVm	
Selectivity	55dB	
Signal to Noise Ratio	53dB	≥ 48dB
Image Rejection	40dB	≥ 30dB
IF Rejection	66dB	≥ 50dB
● <b>DIMENSIONS (W x H x D)</b>	17-3/8" x 2-7/8" x 13-1/2"	
	(442 x 73 x 342 mm)	
● <b>WEIGHT</b>	7.5 lbs. (3.4 kg)	

● **POWER SUPPLIES**

North America area model AC120V, 60Hz  
 International and Australia AC220/240V, 50/60Hz models

● **POWER CONSUMPTION**

North America area model 12W  
 International and Australia 12W models

These specifications are Service target specs.

Specifications and components subject to change without notice. Overall performance will be maintained or improved.

**LEAKAGE TEST (FOR SERVICE ENGINEERS IN THE U.S.A.)**

Before returning the unit to the user, perform the following safety checks:

1. Inspect all lead dress to make certain that leads are not pinched or that hardware is not lodged between the chassis and other metal parts in the unit.
2. Replace all protective devices such as nonmetallic control knobs, insulating fishpapers, cabinet backs, adjustment and compartment covers or shields, isolation resistor-capacitor networks, mechanical insulators, etc.
3. Be sure that no shock hazard exists; check for leakage current using Simpson Model 229 Leakage Tester, standard equipment item No. 21641, RCA Model WT540A or use alternate method as follows:

Plug the AC line cord directly into a 120-volt AC receptacle (do not use an Isolation Transformer for this test). Using two clip leads, connect a 1500 ohm, 10-watt resistor paralleled by a 0.15 μF capacitor, in series with all exposed metal cabinet parts and a known earth ground, such as a water pipe or conduit. Use a VTVM or VOM with 1000 ohms per volt, or higher sensitivity to measure

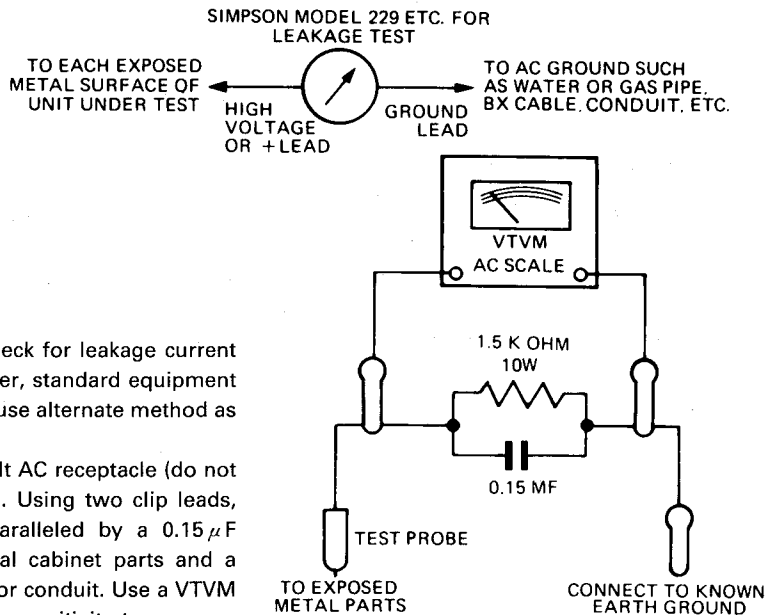

the AC voltage drop across the resistor. (See Diagram.) Move the resistor connection to each exposed metal part having a return path to the chassis (antenna, metal, cabinet, screw heads, knobs and control shafts, escutcheon, etc.) and measure the AC voltage drop across the resistor. (This test should be performed with the power switch in both the On and Off positions.) A reading of 0.35 volt RMS or more is excessive and indicates a potential shock hazard which must be corrected before returning the unit to the owner.

## CONTROLS AND DISPLAYS

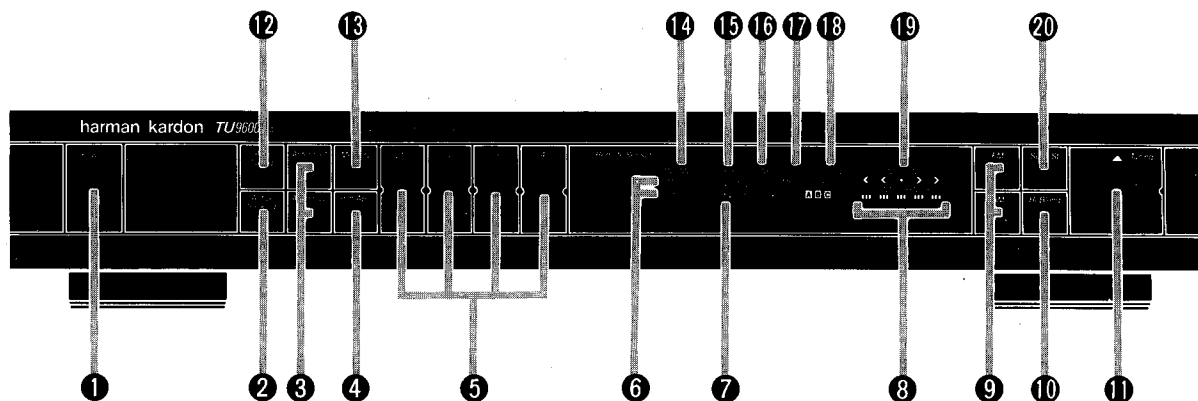

### 1 Power Switch

Press to turn the unit on and off.

### 2 Active Tracking

Press to reduce interference from adjacent stations.

### 3 Antenna 1, 2

When two FM antennas are connected to the unit, use these buttons to select desired antenna.

### 4 Shift ABC

Allows you to access 24 pre-selected stations using the 8 preset buttons.

### 5 Preset Buttons

Press to access pre-selected stations.

### 6

Indicates AM or FM band and frequency of the tuned station.

### 7

Flashes during period when a station can be entered into the memory.

### 8

Number of segments illuminated shows signal strength. when tuning stations or positioning antennas, adjust so that maximum number of segments is illuminated.

### 9 FM/AM

Press to select FM or AM reception.

### 10 Hi-Blend

When tuned to a weak signal (in Seek-St mode), press on to improve sound quality.

### 11 Tuning

Press ▲ to tune to stations with higher frequencies; press ▼ for lower frequencies.

### 12 Fine Tuning

Use with Active Tracking to reduce interference from adjacent stations.

### 13 Memory

Press to set in memory a new preset station.

### 14

Shows which antenna is in use.

### 15

Shows stereo broadcast is being received.

### 16

Indicates station is properly tuned.

### 17

Shows Seek function is on.

### 18

Shows Hi-Blend function is on.

### 19

Lights when Active Tracking is turned on. Arrows and center circle indicate Fine Tuning position.

### 20 Seek-ST

Press on for Seek tuning in stereo, off for manual tuning in mono.

**DISASSEMBLY PROCEDURES (REFER TO PAGES 8 THROUGH 10)****① CABINET TOP REMOVAL**

Remove 7 screws (A) and then remove the Cabinet Top (127).

**② FRONT PANEL ASS'Y (AA) REMOVAL**

1. Remove the Cabinet Top (127), referring to the previous step ①.
2. Disconnect the jumper leads (JL701 and JL702) from connectors (CN701A and CN702A).
3. Remove 5 screws (B) and then remove the Front Panel Ass'y (AA).

**③ MAIN P.C. BOARD (PCB-1) REMOVAL**

1. Remove the Front Panel Ass'y (AA), referring to the previous step ②.
2. Open the lid of connector (CN101) on the Main P.C. Board (PCB-1) and then disconnect the jumper lead (JL101).
3. Remove 9 screws (C) and then remove the Main P.C. Board (PCB-1).
4. Remove 4 screws (D), 2 screws (E) (North America area model only) and shaft (154) and then remove the Power Supply P.C. Board (PCB-3).  
If necessary, unsolder the lead wires connected to the PCB-3.
5. Remove 8 screws (F) and then remove the Front P.C. Board (PCB-2).

**POWER CORD REPLACEMENT (FOR SERVICE ENGINEERS OTHER THAN NORTH AMERICA)**

In order to prevent fire or shock hazard when replacing the power cord, follow the Procedure below to replace the part with the standard supply parts.

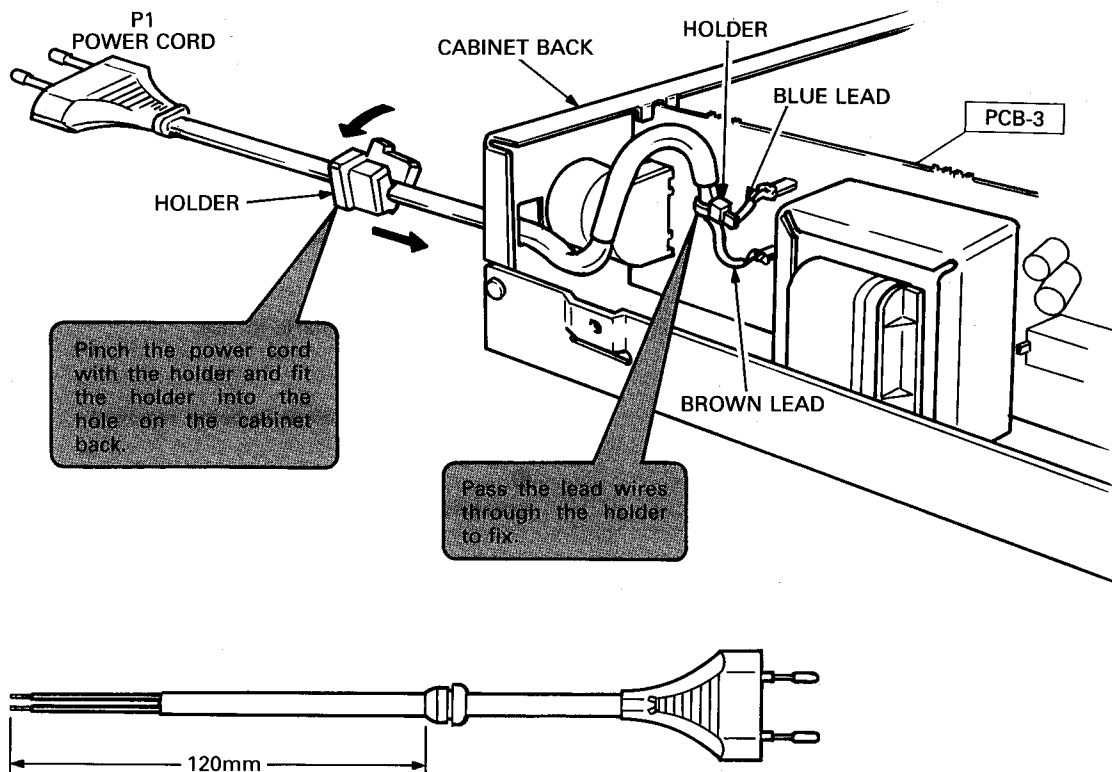

**ALIGNMENT PROCEDURES (REFER TO PAGES 11, 12, 26 AND 27)**

**■ AM ADJUSTMENT**

Conditions: ● Press the "AM" switch.

● Standard modulation of the AM signal Generator is 400Hz at 30%.

※International and Australia models

Step	Alignment	Terminals to be Connected	Measurement Frequency	Station Display	Adjustment	For
1	IF	<ul style="list-style-type: none"> <li>Connect the AM Test Loop Antenna cable into the output jack of AM Signal Generator. Place AM Test Loop Antenna close enough to couple signal into the AM Loop Antenna.</li> <li>Connect the VTVM and oscilloscope to the OUTPUT jacks.</li> </ul>	1400kHz ※1404kHz	1400kHz ※1404kHz	L251 L252	Maximum output level and symmetrical curve on scope.
2	Tracking		1400kHz ※1404kHz	1400kHz ※1404kHz	TC251	Maximum output.
3			600kHz ※603kHz	600kHz ※603kHz	T251	Maximum output.
4			Repeat steps 2 and 3 for optimum sensitivity.			
5	Signal indicator		1000kHz ※999kHz	1000kHz ※999kHz	VR251	Adjust so that the 5 SIGNAL STRENGTH indicator lights at 1000 μV/m input.

**■ FM ADJUSTMENT**

Conditions: ● Press the "FM" switch.

● Set the "Seek-ST" switch to off (put out seek indicator) position.

	North America area model	International and Australia models
FM Signal Generator	1kHz, 100% modulation	1kHz, 40kHz modulation
Stereo Modulator	L+R=45.5%, L-R=45.5%, 19kHz=9%	L+R=22.5%, L-R=22.5%, 19kHz=8%

Step	Alignment	Terminals to be Connected	Measurement Frequency	Station Display	Adjustment	For
1	Discriminator	<ul style="list-style-type: none"> <li>Connect the FM Signal Generator to FM 75 Ω UNBAL Antenna terminal. [500 μV/75 Ω (65dBf) input]</li> <li>International and Australia models: 1kHz, 40kHz mod.</li> </ul>	98.1MHz ±30~40kHz	98.1MHz	T201(A)	Adjust so that the TUNED indicator lights in the same range on both plus (+) and minus (-) sides of 98.1 MHz.
2			98.1MHz	98.1MHz	T201(B)	Minimum distortion.
3			Repeat steps 1 and 2 for optimum sensitivity.			
4	Tuned indicator		98.1MHz	98.1MHz	VR202	Adjust so that the TUNED indicator lights at 9 μV/75 Ω (30dBf) input. (32 μV/75 Ω input for International and Australia models.)
5	Signal indicator		98.1MHz	98.1MHz	VR201	Adjust so that the 5 SIGNAL STRENGTH indicator lights at 280 μV/75 Ω (60dBf) input.

Step	Alignment	Terminals to be Connected	Measurement Frequency	Station Display	Adjustment	For
6	Active tracking	<ul style="list-style-type: none"> <li>Connect the FM Signal Generator to FM 75Ω UNBAL Antenna terminal. [500 μV/75Ω (65dBf) input] [1kHz, 100kHz mod.]</li> <li>Connect the Distortion meter and Oscilloscope to the OUTPUT jacks.</li> </ul>	98.1MHz	98.1MHz	T202 TC201	Adjust T202 so that the upper and lower parts of waveform are symmetrical and TC201 so as to obtain the waveform immediately before clipping.
7	Signal indicator	( International and Australia models: ) 1kHz, 75kHz mod.	98.1MHz	98.1MHz	VR203	Adjust so that 5 SIGNAL STRENGTH light at 220 μV/75Ω (55dBf) input.
8	Pilot cancel	<ul style="list-style-type: none"> <li>Connect the Stereo Modulator to FM signal Generator.</li> <li>Connect FM signal Generator to FM signal Generator to FM 75Ω UNBAL Antenna terminal.</li> </ul>	98.1MHz	98.1MHz	VR302	Minimum output level and symmetrical curve on scope.
9	Separation	<ul style="list-style-type: none"> <li>Connect the VTVM and Oscilloscope to the OUTPUT jacks.</li> </ul>	98.1MHz	98.1MHz	VR301	Adjust so that the left channel output becomes minimum when only the right channel of the Stereo Modulator is modulated.
					VR301	Adjust so that the right channel output becomes minimum when only the left channel of the Stereo Modulator is modulated.

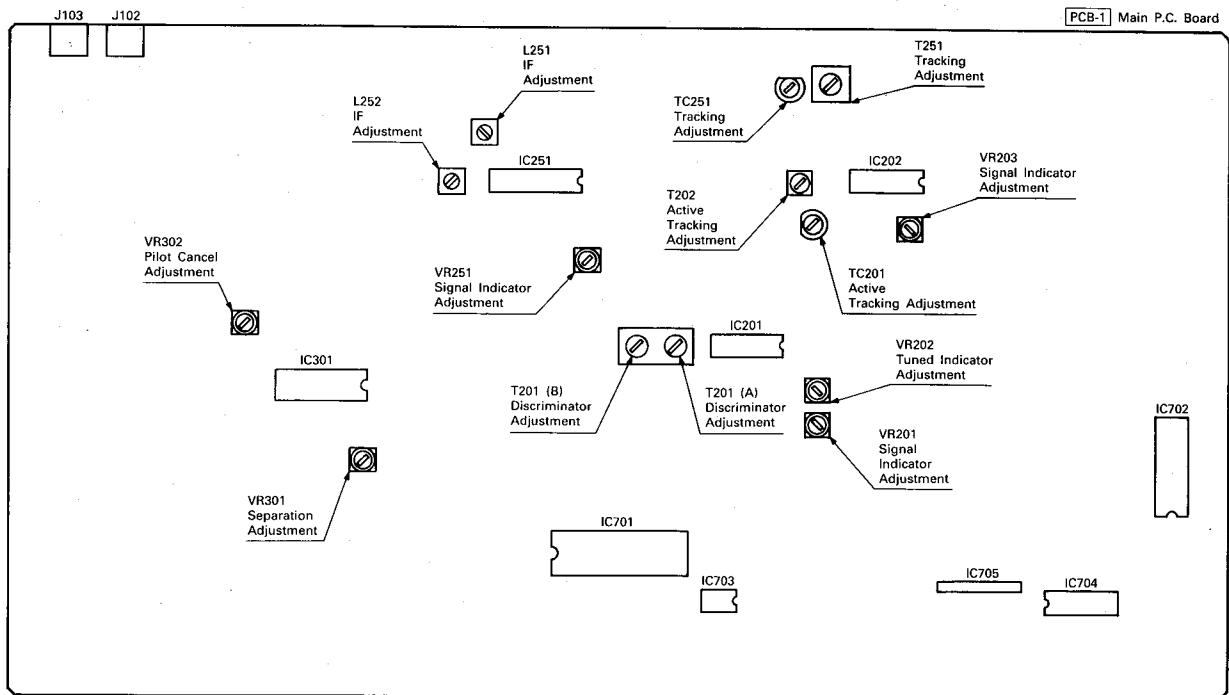

Alignment Point Location

**CIRCUIT DESCRIPTION**

**● FM TUNER SECTION**

The signal which has entered through the antenna is high-frequency amplified in front end FE101, mixed with the output of the local oscillator and converted into the 10.7MHz intermediate frequency.

The 10.7MHz signal is amplified in the intermediate frequency amplifying section which consists of CF201, Q201, CF202 and Q202 and fed to pin 1 of IC201. In IC201, the signal is transmitted through the IF amplifier in six steps, detected in the quadrature detector and after going through the AF amplifier it is sent to pin 6.

Then it is fed to pin 24 of IC301. In IC301, the pilot signal is detected and a 38kHz signal is produced. The stereo signal is demodulated by the 38kHz signal and sent to pin 8 (left channel) and pin 20 (right channel).

**● ACTIVE TRACKING CIRCUIT**

To reduce interference from strong FM adjacent stations, the Hi Q mode can be selected. In the Hi Q mode, the 10.7MHz IF signal then passes through CF203, Q203 and CF204 into pin 1 of IC202. In IC202, the phase of this signal is compared with the phase of the VCO signal generated by Q207 and Q208, varicap diode D209 and T202.

The phase comparison is made between pin 1 and pin 9 of IC202. The output of the phase comparator (pin 6 of IC202) is again fed to the external LPF transistor Q205 and Q206. The phase compared 10.7MHz signal at T202 is fed into pin 1 of IC201 through C229, D204 and C210.

When the FINE TUNE front panel control setting is changed, the DC bias voltage of varicap diode D209 changes and the center frequency of the Q207 and Q208 VCO is varied. By means of this system, interference from other FM stations can be reduced or eliminated.

**● AM TUNER SECTION**

The signal which has entered through the antenna is transmitted through the tuning circuit consisting of T251 and TC251, also fed to pin 3 of IC251. In IC251, it undergoes high-frequency amplification, local oscillation, mixing, intermediate frequency amplification and detection, and then output from pin 13. This signal is fed to pin 23 of IC301.

**● MUTING CIRCUIT**

If FM is received out of tuning or in a very weak field intensity, pin 12 of IC201 becomes high level. Then this is supplied to the base of Q707, whereby Q745 turn ON. As a result, Q311 (L ch) and Q312 (R ch) also turn ON to mute the output.

**● SYNTHESIZER SECTION**

**• FM**

The local oscillation output signal is fed from the front end unit FE101 to pin 21 of the prescaler IC702 and after being frequency divided into 15 or 16, it is fed to IC701. In IC701, the standard frequency is oscillated by the crystal oscillator, compared with the divided local oscillation output signal, it is fed to IC702 and output to pin 16. This voltage is level converted at Q701 and Q702, and fed to the varicap diode in the front end unit.

**• AM**

The local oscillation output signal is fed from pin 20 of IC251 to pin 19 of the prescaler IC702. In IC702, the standard frequency is oscillated by the crystal oscillator, compared with the local oscillation output signal, it is fed to IC702 and output to pin 16.

**● INDICATOR SECTION**

**• Frequency display**

The serial data sent out of pin 35 of the digital synthesizer tuning system micro controller IC701 is fed to pin 29 of IC706, where the data is decoded to provide a signal which turns ON the indicator.

**• Signal strength**

The voltage corresponding to the signal level is output from pin 13 of IC201 (for FM) and pin 16 of IC251 (for AM), fed to pin 8 of the level comparator IC705. Then it is further sent through Exclusive OR Q731, Q732, Q733, Q734 and Q735 to the indicator, whereby the signal strength segments 1 to 5 light according to the signal level.

**• Tuning**

When tuning, the control signal is fed to IC704 from IC701. The output is sent to Q726, Q727, Q728, Q729 and Q730 to the indicator, whereby the fine tuning segment of the indicator lights according to the tuning direction.

**TIMING CHART IC703 (AK93C46)**

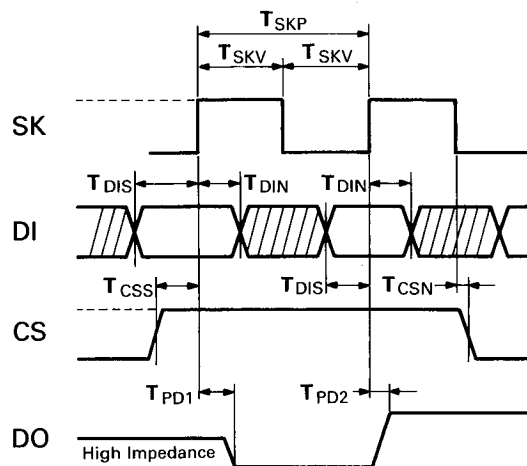

**BLOCK DIAGRAM**

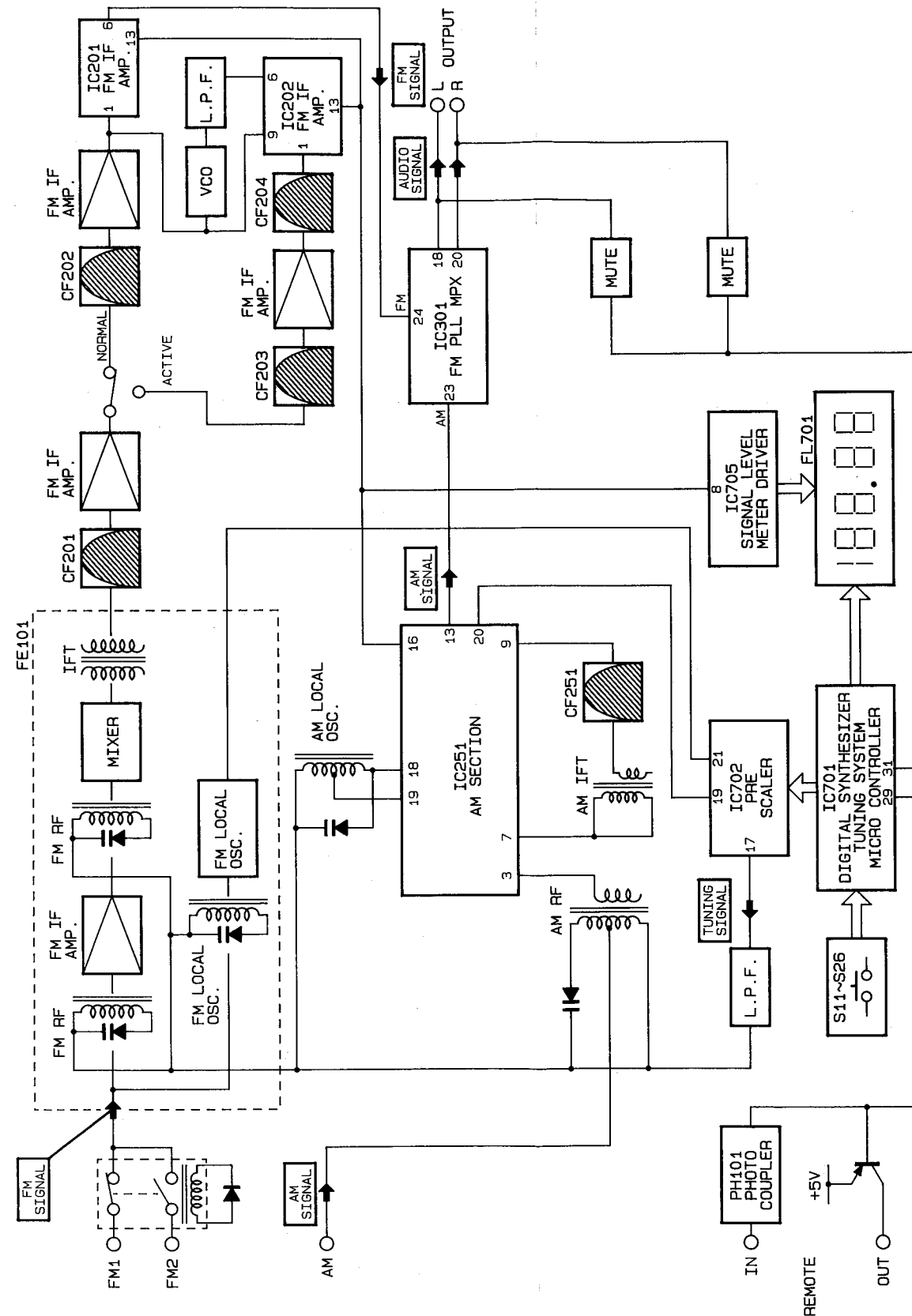

## CIRCUIT DESCRIPTION

### ● FM TUNER SECTION

The signal which has entered through the antenna is high-frequency amplified in front end FE101, mixed with the output of the local oscillator and converted into the 10.7MHz intermediate frequency.

The 10.7MHz signal is amplified in the intermediate frequency amplifying section which consists of CF201, Q201, CF202 and Q202 and fed to pin 1 of IC201. In IC201, the signal is transmitted through the IF amplifier in six steps, detected in the quadrature detector and after going through the AF amplifier it is sent to pin 6.

Then it is fed to pin 24 of IC301. In IC301, the pilot signal is detected and a 38kHz signal is produced. The stereo signal is demodulated by the 38kHz signal and sent to pin 8 (left channel) and pin 20 (right channel).

### ● ACTIVE TRACKING CIRCUIT

To reduce interference from strong FM adjacent stations, the Hi Q mode can be selected. In the Hi Q mode, the 10.7MHz IF signal then passes through CF203, Q203 and CF204 into pin 1 of IC202. In IC202, the phase of this signal is compared with the phase of the VCO signal generated by Q207 and Q208, varicap diode D209 and T202.

The phase comparison is made between pin 1 and pin 9 of IC202. The output of the phase comparator (pin 6 of IC202) is again fed to the external LPF transistor Q205 and Q206. The phase compared 10.7MHz signal at T202 is fed into pin 1 of IC201 through C229, D204 and C210.

When the FINE TUNE front panel control setting is changed, the DC bias voltage of varicap diode D209 changes and the center frequency of the Q207 and Q208 VCO is varied. By means of this system, interference from other FM stations can be reduced or eliminated.

### ● AM TUNER SECTION

The signal which has entered through the antenna is transmitted through the tuning circuit consisting of T251 and TC251, also fed to pin 3 of IC251. In IC251, it undergoes high-frequency amplification, local oscillation, mixing, intermediate frequency amplification and detection, and then output from pin 13. This signal is fed to pin 23 of IC301.

### ● MUTING CIRCUIT

If FM is received out of tuning or in a very weak field intensity, pin 12 of IC201 becomes high level. Then this is supplied to the base of Q707, whereby Q745 turn ON. As a result, Q311 (L ch) and Q312 (R ch) also turn ON to mute the output.

### ● SYNTHESIZER SECTION

#### • FM

The local oscillation output signal is fed from the front end unit FE101 to pin 21 of the prescaler IC702 and after being frequency divided into 15 or 16, it is fed to IC701. In IC701, the standard frequency is oscillated by the crystal oscillator, compared with the divided local oscillation output signal, it is fed to IC702 and output to pin 16. This voltage is level converted at Q701 and Q702, and fed to the varicap diode in the front end unit.

#### • AM

The local oscillation output signal is fed from pin 20 of IC251 to pin 19 of the prescaler IC702. In IC702, the standard frequency is oscillated by the crystal oscillator, compared with the local oscillation output signal, it is fed to IC702 and output to pin 16.

### ● INDICATOR SECTION

#### • Frequency display

The serial data sent out of pin 35 of the digital synthesizer tuning system micro controller IC701 is fed to pin 29 of IC706, where the data is decoded to provide a signal which turns ON the indicator.

#### • Signal strength

The voltage corresponding to the signal level is output from pin 13 of IC201 (for FM) and pin 16 of IC251 (for AM), fed to pin 8 of the level comparator IC705. Then it is further sent through Exclusive OR Q731, Q732, Q733, Q734 and Q735 to the indicator, whereby the signal strength segments 1 to 5 light according to the signal level.

#### • Tuning

When tuning, the control signal is fed to IC704 from IC701. The output is sent to Q726, Q727, Q728, Q729 and Q730 to the indicator, whereby the fine tuning segment of the indicator lights according to the tuning direction.

## TIMING CHART IC703 (AK93C46)

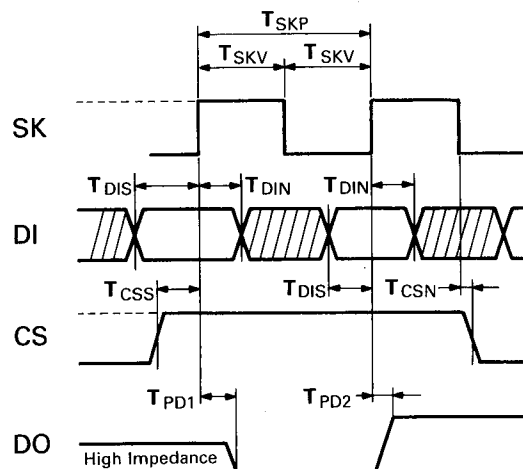



BLOCK DIAGRAM

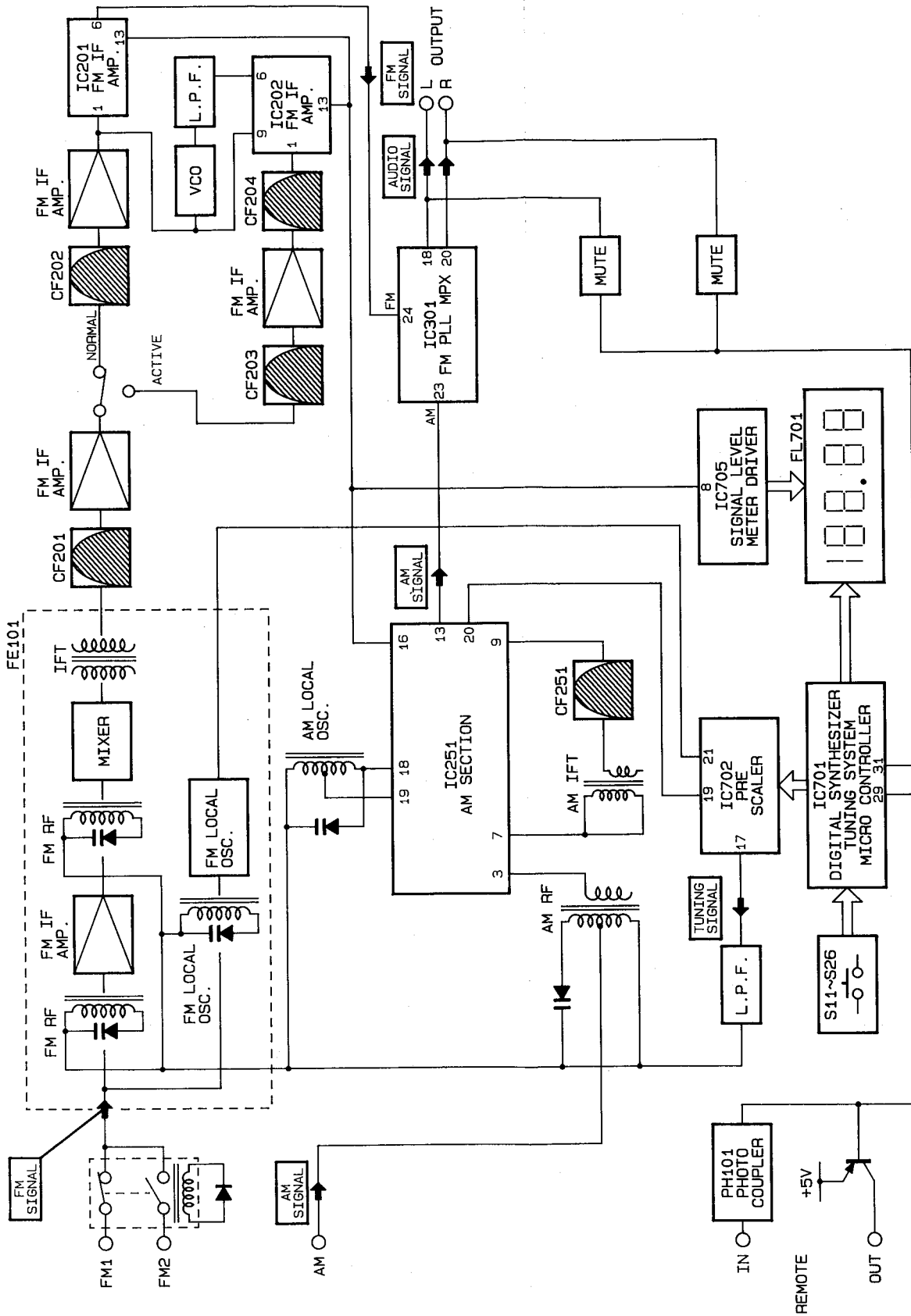

GENERAL UNIT  
EXPLODED VIEW (FRONT PANEL)

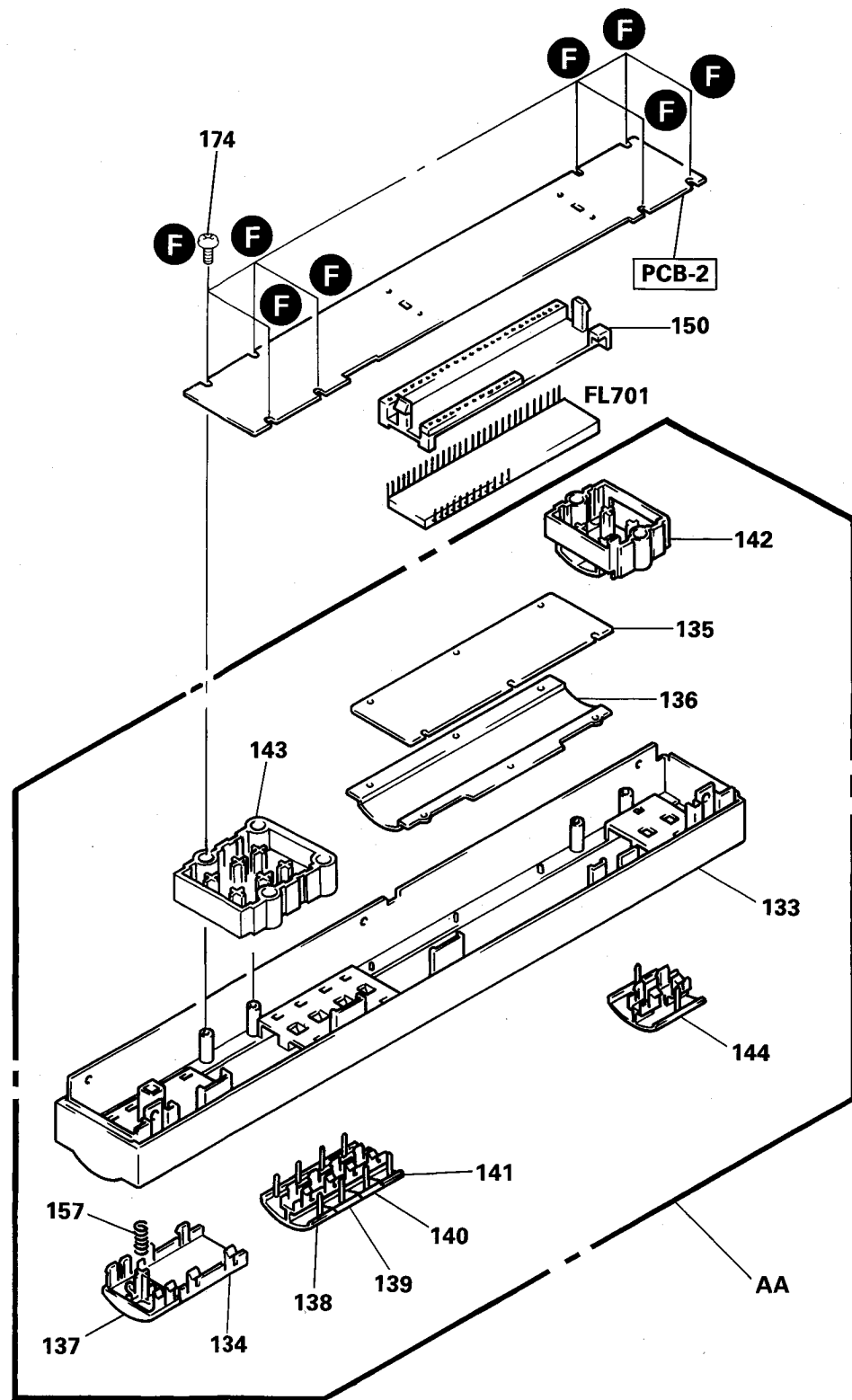

PARTS LIST

Ref. No.	Part No.	Description
AA	A442-TU9600B	FRONT PANEL ASSY (BK IB BB)
133	1442-24504	PANEL
134	1442-24602	PANEL
135	1511-19805	PLATE
136	1532-17505	WINDOW
137	1662-52001	PUSH BUTTON, POWER
138	1662-58605	PUSH BUTTON, PRESET 1/5
139	1662-58606	PUSH BUTTON, PRESET 2/6
140	1662-58607	PUSH BUTTON, PRESET 3/7
141	1662-58608	PUSH BUTTON, PRESET 4/8
142	1662-58702	PUSH BUTTON, FM, AM, SEEK-ST, HI-BLEND
143	1662-58802	PUSH BUTTON, FINE TUNING, ACTIVE TRACKING, ANTENNA 1, 2, MEMORY, SHIFT ABC
144	1662-58902	PUSH BUTTON, TUNING
150	2240-7372	HOLDER
157	2651-2101734	SPRING
174	2347-R0126082	SCREW (2.6 x 8mm)

**GENERAL UNIT  
EXPLODED VIEW (FRONT PANEL)**

1  
2  
3  
4  
5  
6  
7

A B C D E

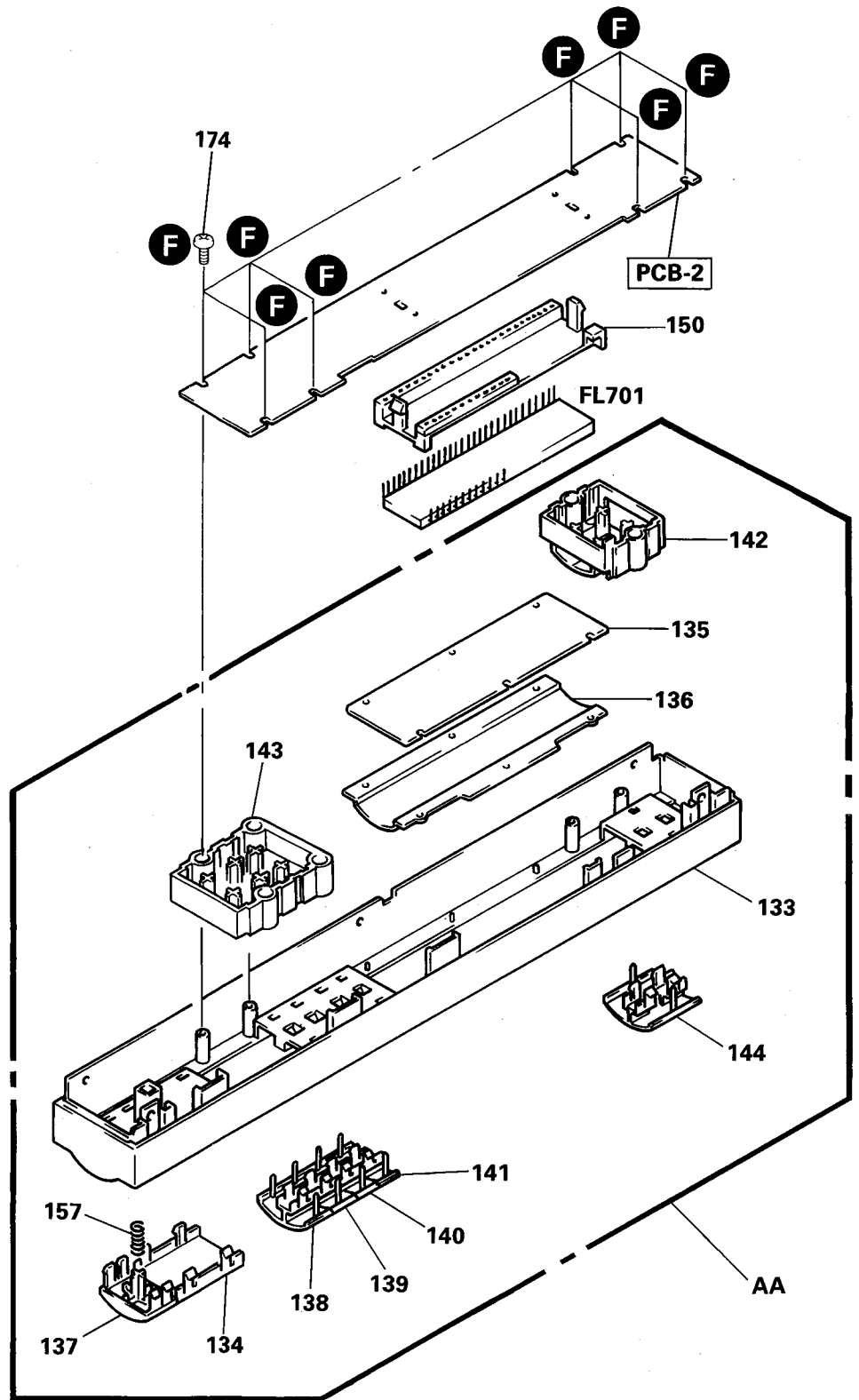

**PARTS LIST**

<u>Ref. No.</u>	<u>Part No.</u>	<u>Description</u>
AA	A442-TU9600B	FRONT PANEL ASSY <b>BK</b> <b>IB</b> <b>EB</b>
133	1442-24504	PANEL
134	1442-24602	PANEL
135	1511-19805	PLATE
136	1532-17505	WINDOW
137	1662-52001	PUSH BUTTON, POWER
138	1662-58605	PUSH BUTTON, PRESET 1/5
139	1662-58606	PUSH BUTTON, PRESET 2/6
140	1662-58607	PUSH BUTTON, PRESET 3/7
141	1662-58608	PUSH BUTTON, PRESET 4/8
142	1662-58702	PUSH BUTTON, FM, AM, SEEK-ST, HI-BLEND
143	1662-58802	PUSH BUTTON, FINE TUNING, ACTIVE TRACKING, ANTENNA 1, 2, MEMORY, SHIFT ABC
144	1662-58902	PUSH BUTTON, TUNING
150	2240-7372	HOLDER
157	2651-2101734	SPRING
174	2347-R0126082	SCREW (2.6 x 8mm)



**GENERAL UNIT  
EXPLODED VIEW**

1  
2  
3  
4  
5  
6  
7

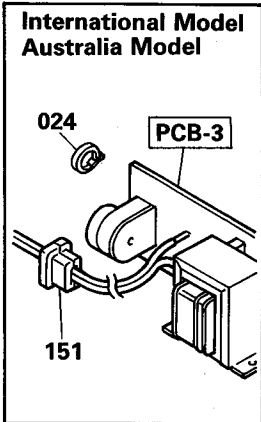
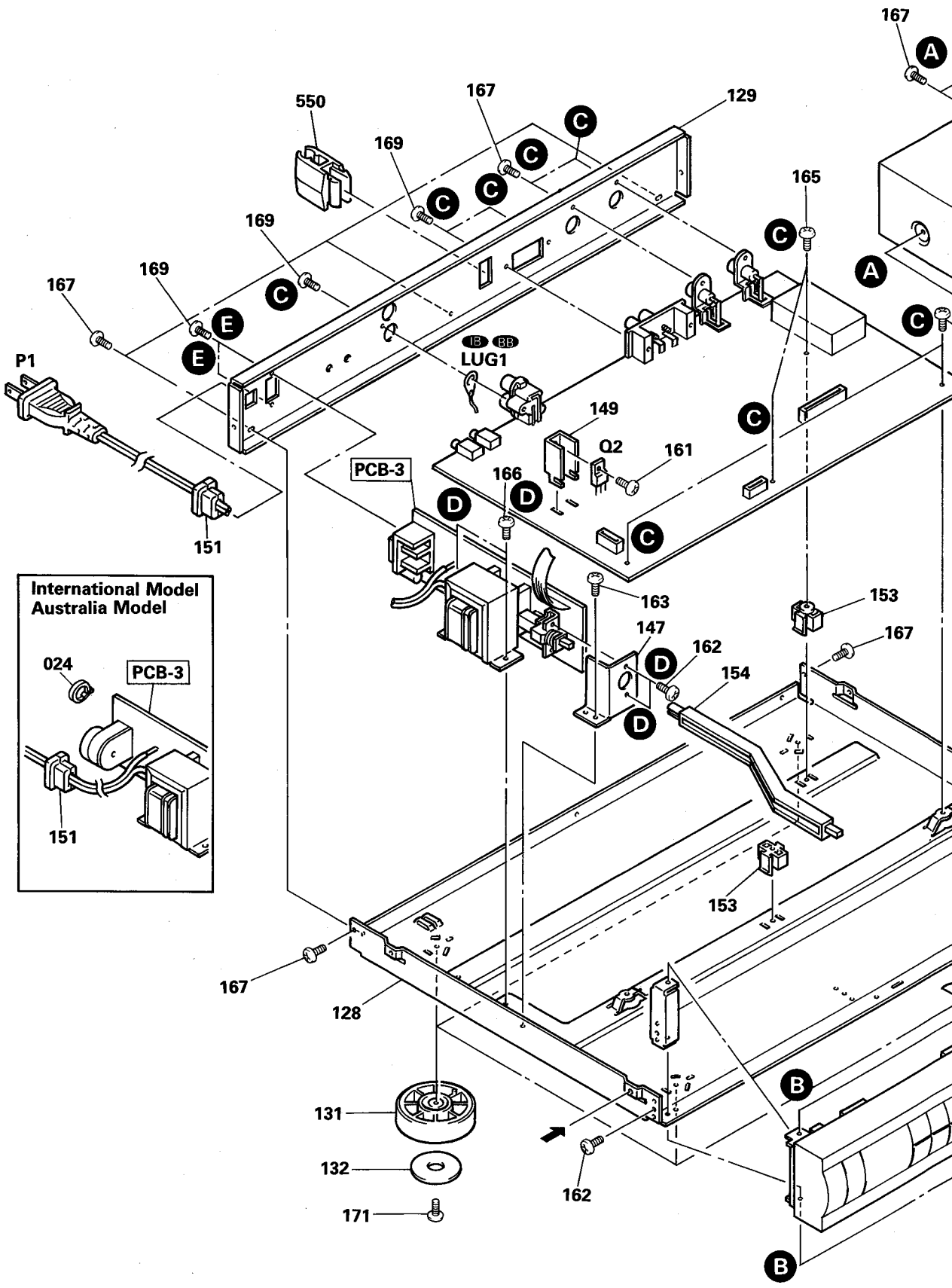

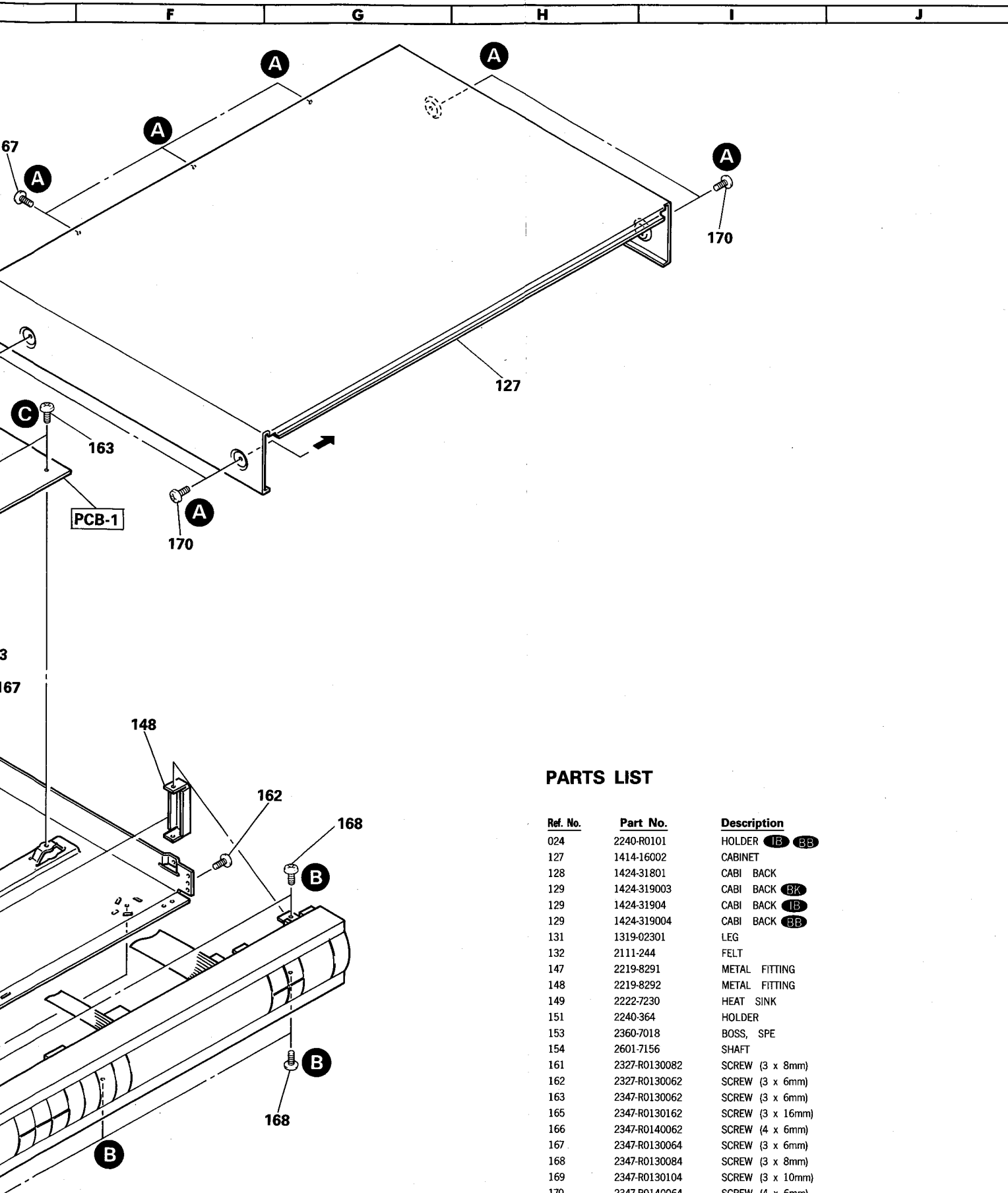

**PARTS LIST**

Ref. No.	Part No.	Description
024	2240-R0101	HOLDER <b>IB</b> <b>BB</b>
127	1414-16002	CABINET
128	1424-31801	CABI BACK
129	1424-319003	CABI BACK <b>BK</b>
129	1424-31904	CABI BACK <b>IB</b>
129	1424-319004	CABI BACK <b>BB</b>
131	1319-02301	LEG
132	2111-244	FELT
147	2219-8291	METAL FITTING
148	2219-8292	METAL FITTING
149	2222-7230	HEAT SINK
151	2240-364	HOLDER
153	2360-7018	BOSS, SPE
154	2601-7156	SHAFT
161	2327-R0130082	SCREW (3 x 8mm)
162	2327-R0130062	SCREW (3 x 6mm)
163	2347-R0130062	SCREW (3 x 6mm)
165	2347-R0130162	SCREW (3 x 16mm)
166	2347-R0140062	SCREW (4 x 6mm)
167	2347-R0130064	SCREW (3 x 6mm)
168	2347-R0130084	SCREW (3 x 8mm)
169	2347-R0130104	SCREW (3 x 10mm)
170	2347-R0140064	SCREW (4 x 6mm)
171	2347-R0140104	SCREW (4 x 10mm)
550	2240-7208	HOLDER

WIRING DIAGRAM

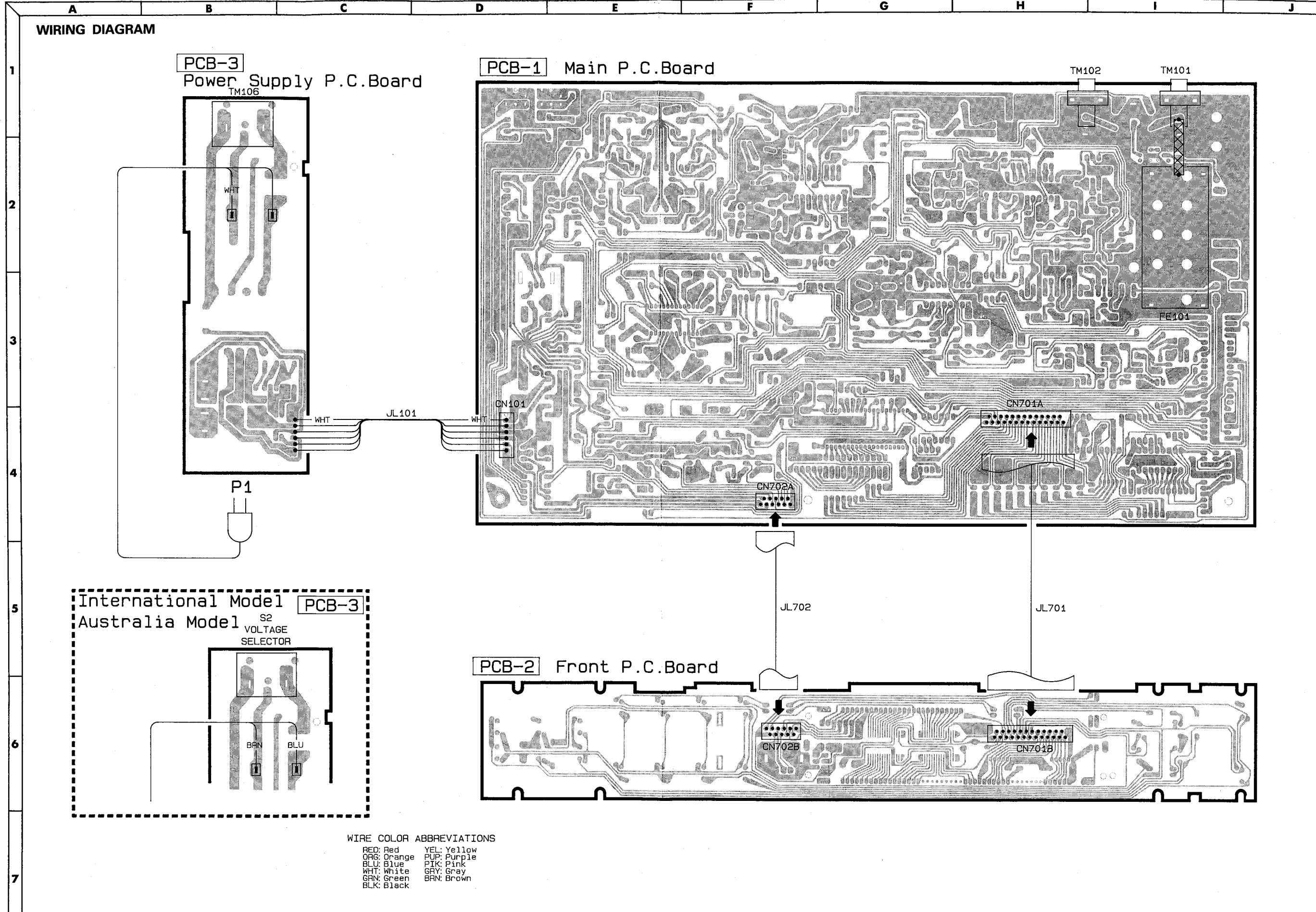

PCB-3  
Power Supply P.C. Board

PCB-1 Main P.C. Board

PCB-2 Front P.C. Board

International Model  
Australia Model

PCB-3

S2  
VOLTAGE  
SELECTOR

WIRE COLOR ABBREVIATIONS

RED: Red	YEL: Yellow
ORG: Orange	PUR: Purple
BLU: Blue	PIK: Pink
WHT: White	GRY: Gray
GRN: Green	BRN: Brown
BLK: Black	



WIRING DIAGRAM

1  
2  
3  
4  
5  
6  
7

A B C D E

**PCB-3**  
Power Supply P.C.Board  
TM106

**PCB-1** Main P.C.Board

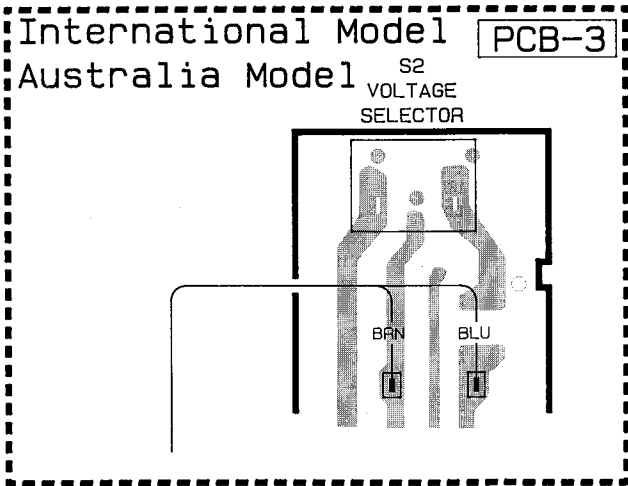
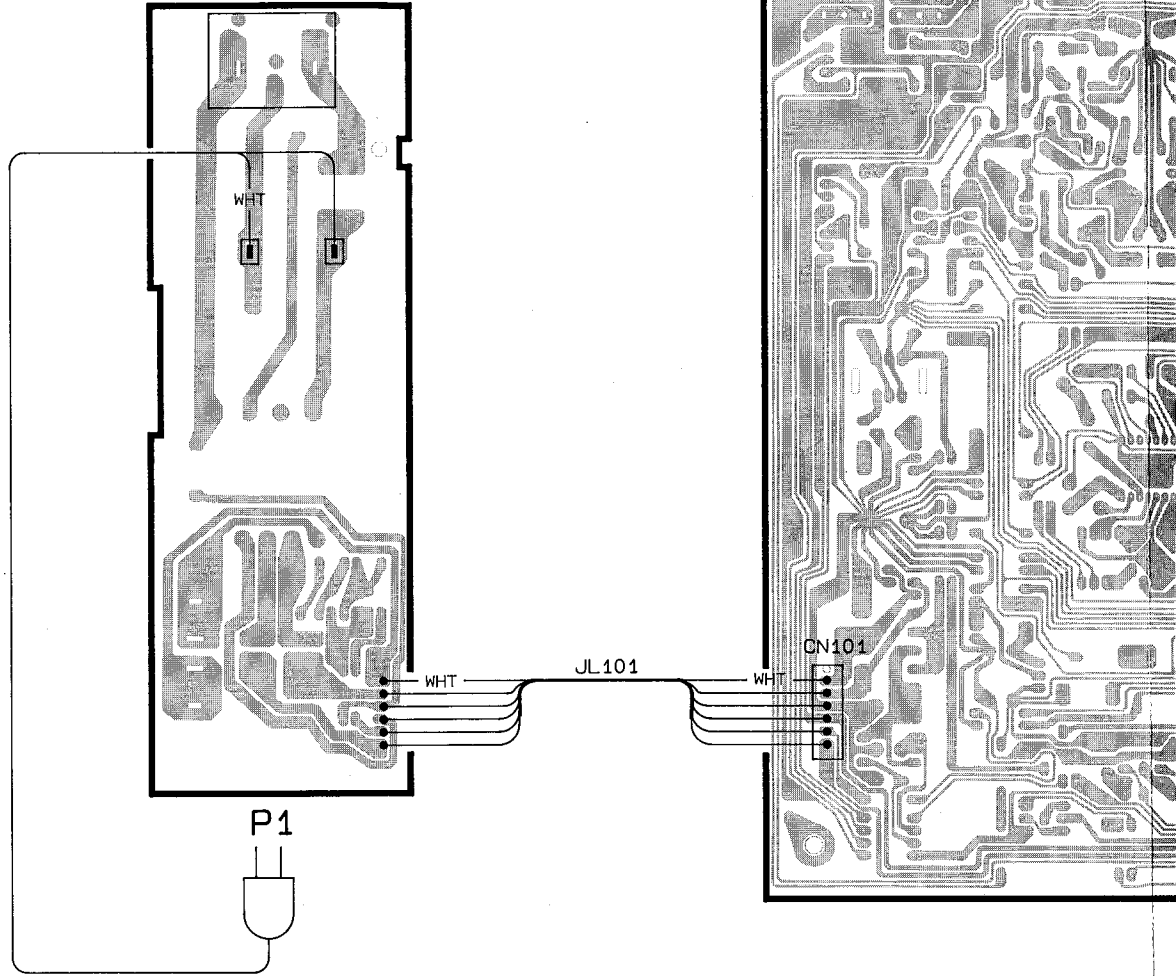

**PCB-2** Front P.C.Board

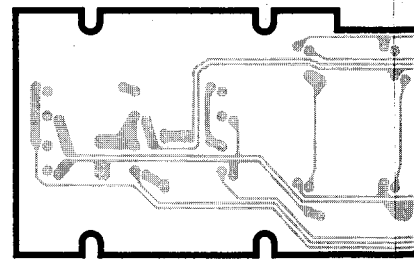

WIRE COLOR ABBREVIATIONS

- |             |             |
|-------------|-------------|
| RED: Red    | YEL: Yellow |
| ORG: Orange | PUP: Purple |
| BLU: Blue   | PIK: Pink   |
| WHT: White  | GRY: Gray   |
| GRN: Green  | BRN: Brown  |
| BLK: Black  |             |

F

G

H

I

J

C. Board

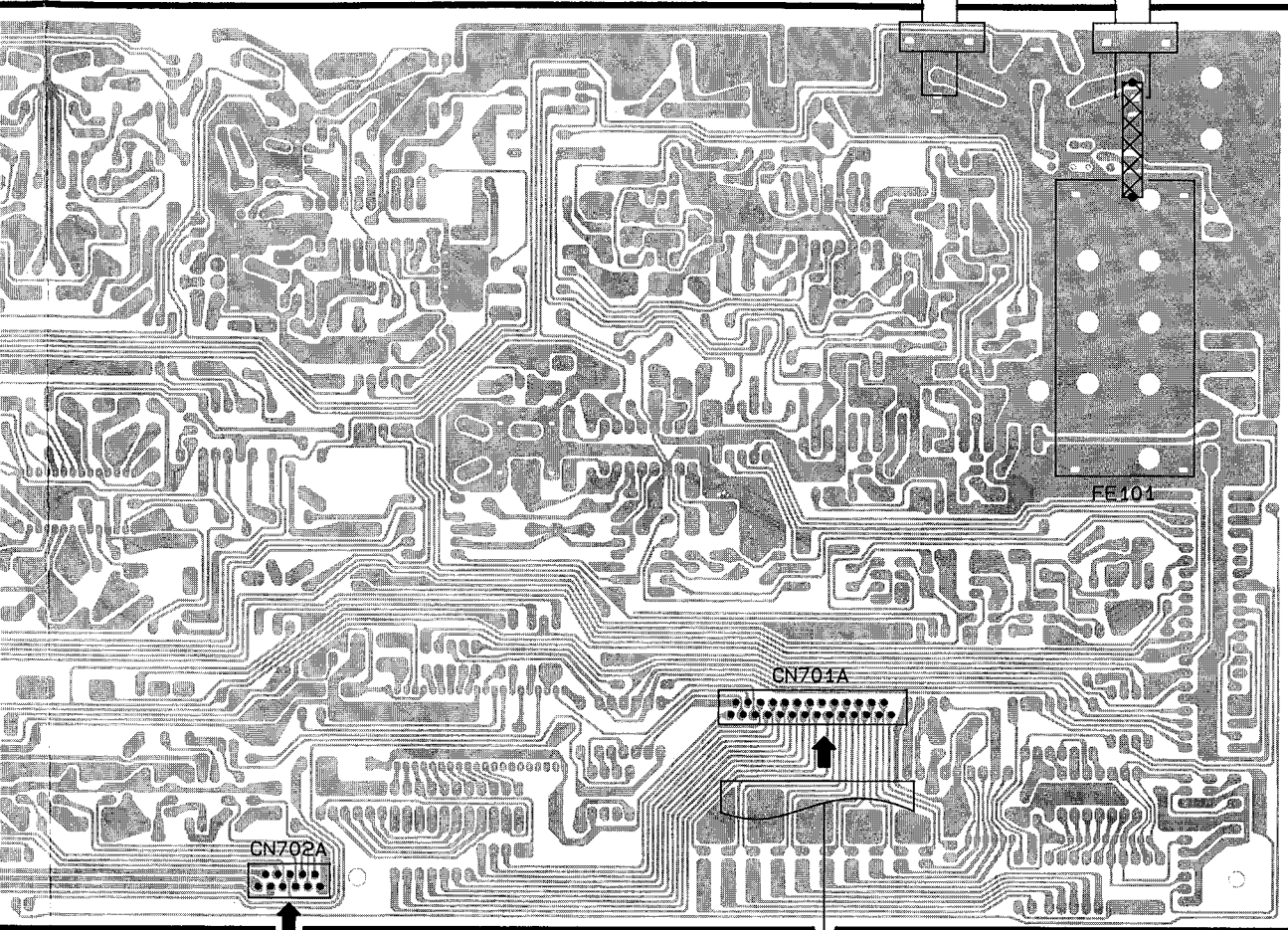

.C. Board

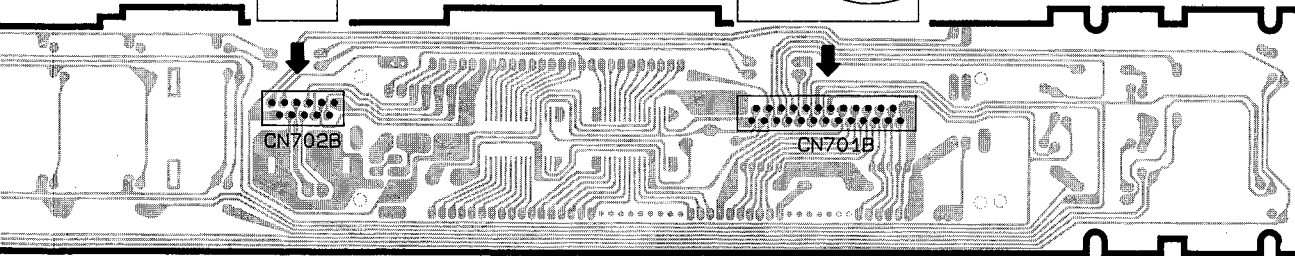

P.C. BOARDS

PCB-1 Main P.C. Board

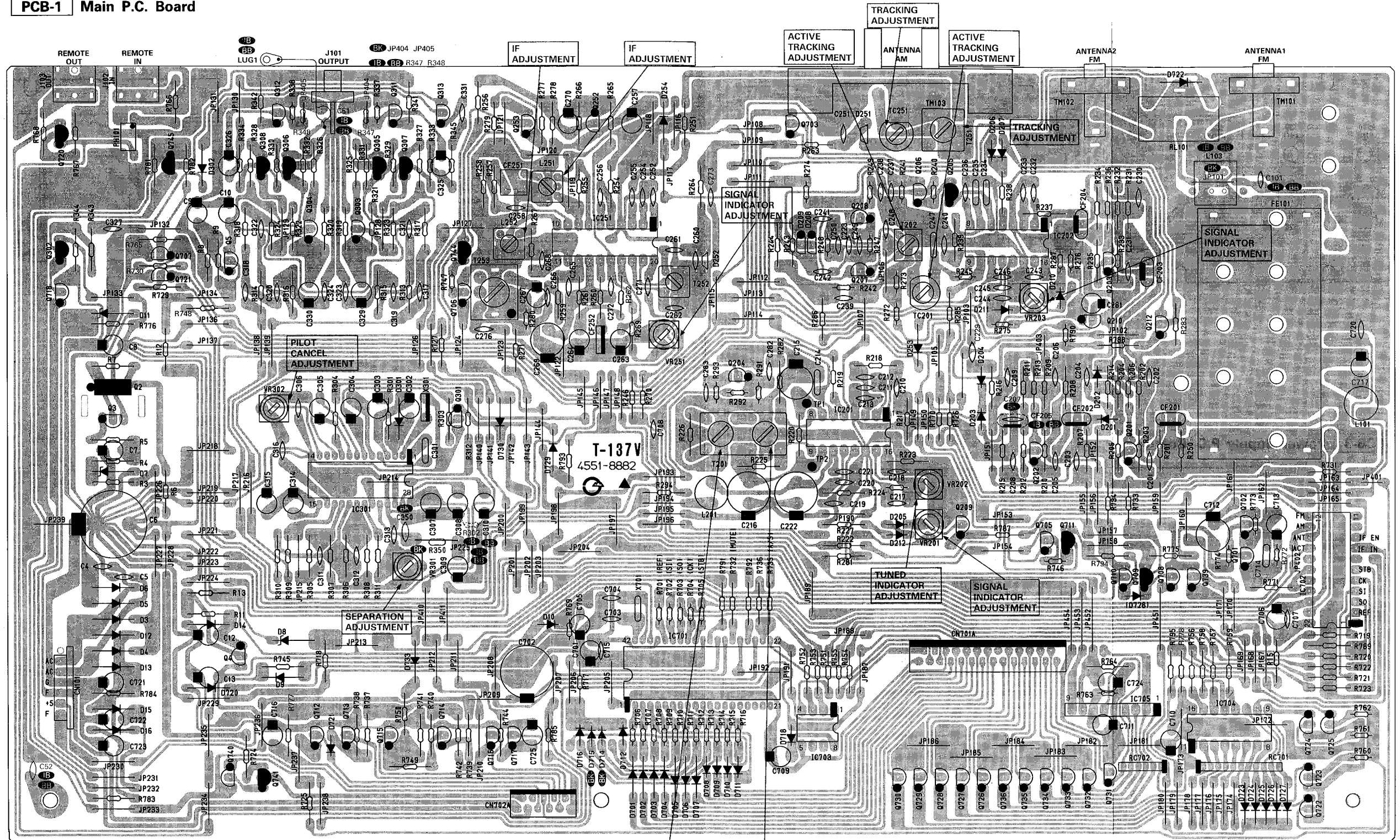

DISCRIMINATOR  
ADJUSTMENT  
T201(B)  
MINIMUM  
DISTORTION

DISCRIMINATOR  
ADJUSTMENT  
T201(A)  
CENTER  
DISTORTION

1  
2  
3  
4  
5  
6  
7





F

G

H

I

J

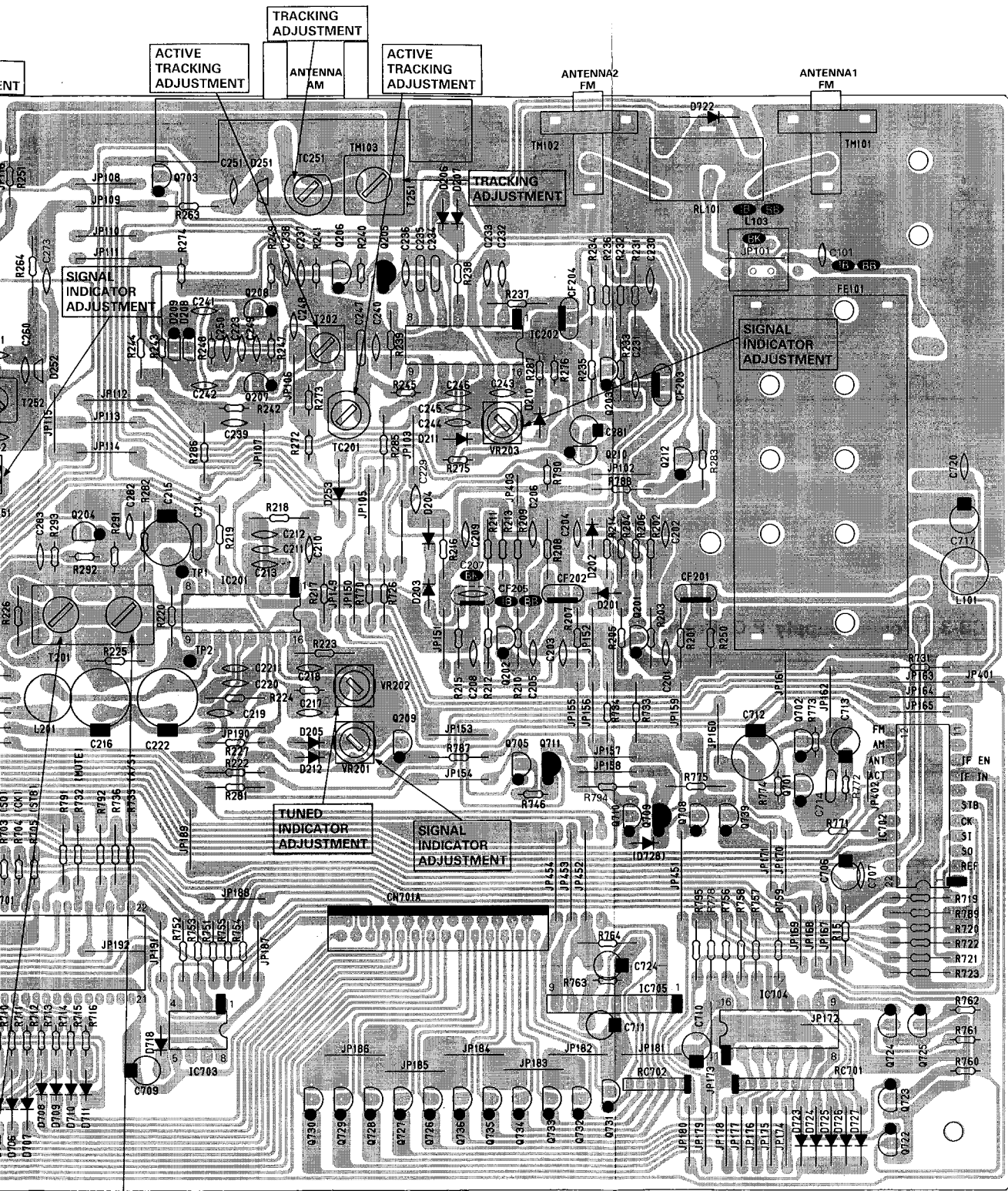

DISCRIMINATOR ADJUSTMENT  
T201(A)  
CENTER DISTORTION

P.C. BOARDS

PCB-2 Front P.C. Board

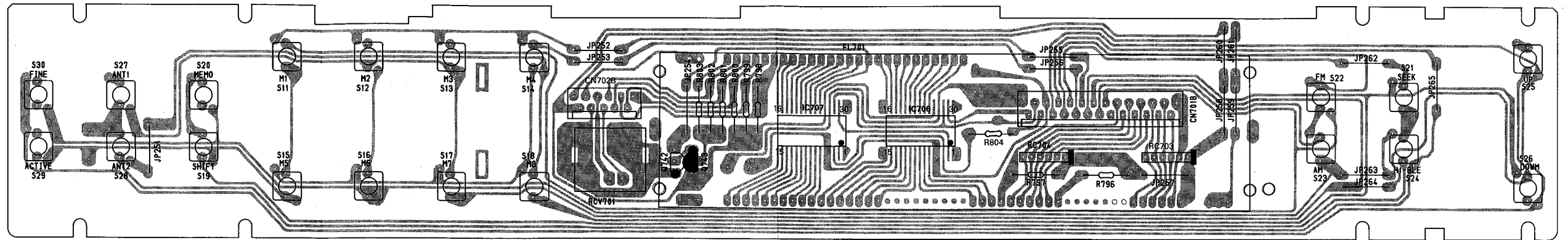

PCB-3 Power Supply P.C. Board

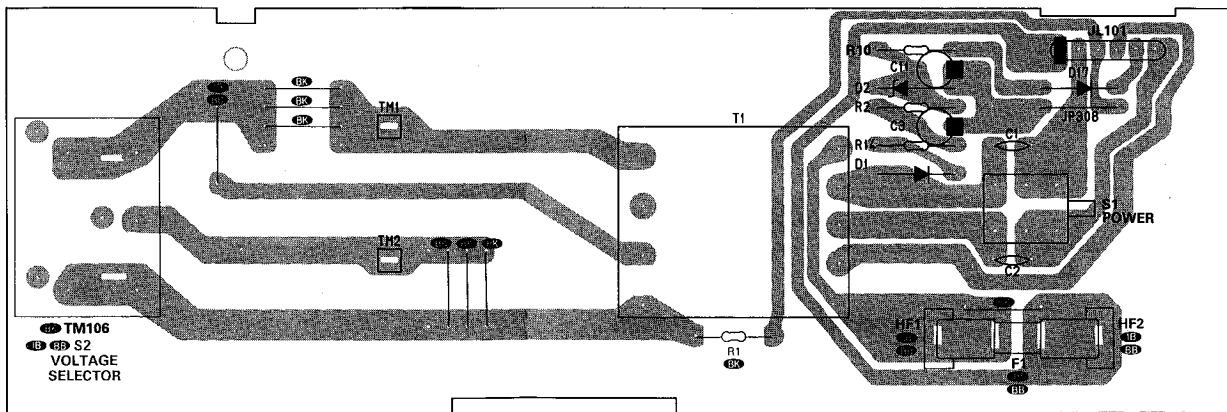

**P.C. BOARDS**

**PCB-2 Front P.C. Board**

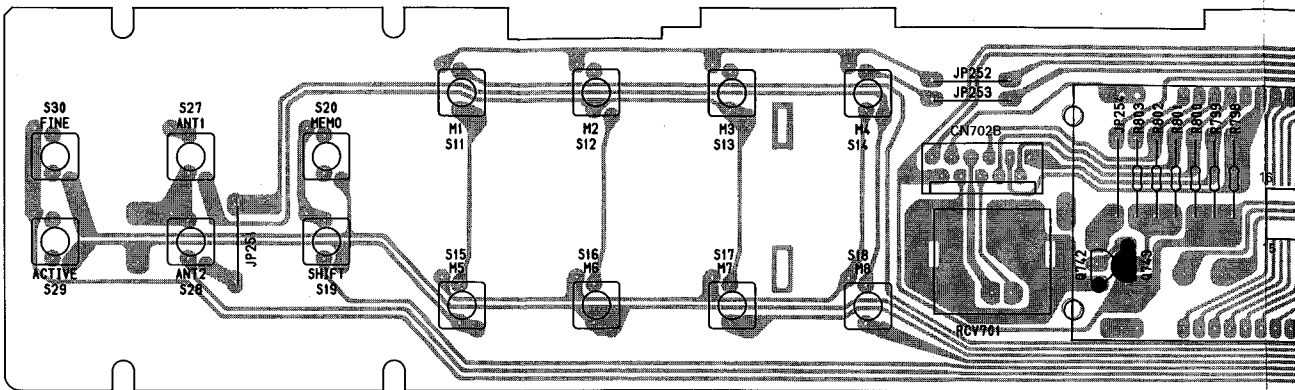

**PCB-3 Power Supply P.C. Board**

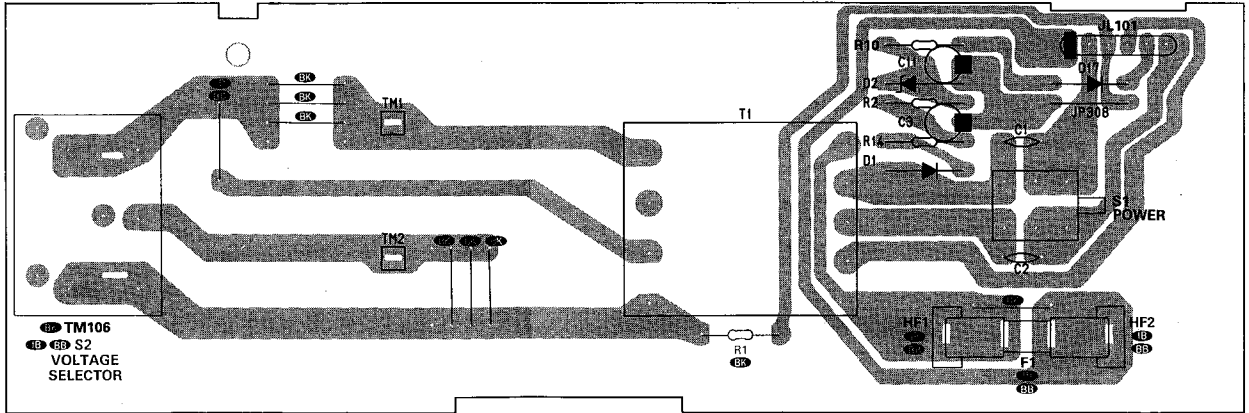

TM106  
 S2  
**VOLTAGE SELECTOR**

F

G

H

I

J

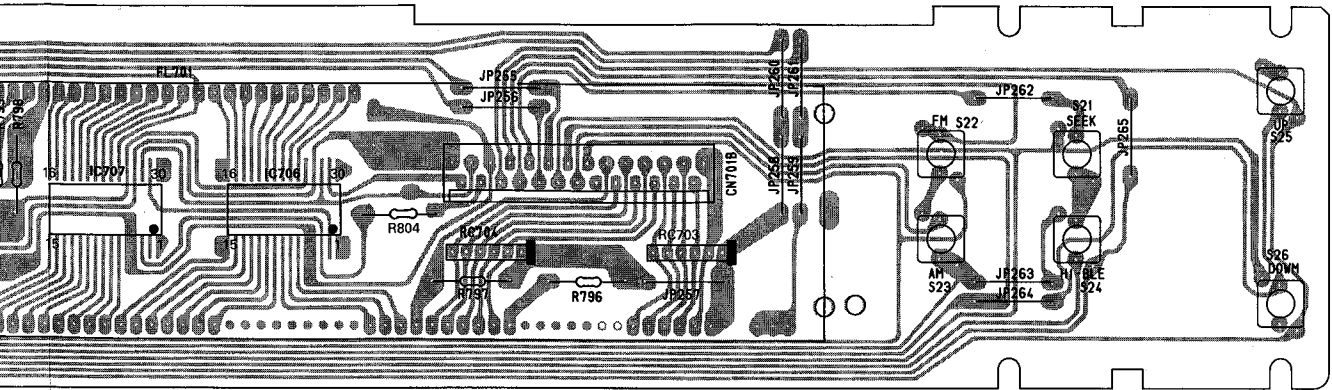



## ELECTRICAL PARTS LIST

Ser. No.	Ref. No.	Part No.	Description	Ser. No.	Ref. No.	Part No.	Description
<b>PCB-1 MAIN P.C. BOARD</b>							
<b>CAPACITORS</b>							
722	C4	5361-473ZF	CAP, CER .047 $\mu$	539	C267	5345-105F041	CAP, MINI ELE 1 $\mu$ /50V
722	C5	5361-473ZF	CAP, CER .047 $\mu$	542	C268	5361-102K918	CAP, CER 1000p
717	C6	5345-228D045	CAP, MINI ELE 2200 $\mu$ /25V	537	C269	5345-107C041	CAP, MINI ELE 100 $\mu$ /16V
715	C7	5345-107D041	CAP, MINI ELE 100 $\mu$ /25V	538	C270	5345-104F041	CAP, MINI ELE .1 $\mu$ /50V
718	C8	5345-476D041	CAP, MINI ELE 47 $\mu$ /25V	541	C271	5361-223Z921	CAP, CER .022 $\mu$
718	C9	5345-476D041	CAP, MINI ELE 47 $\mu$ /25V	543	C272	5361-473ZF	CAP, CER .047 $\mu$
718	C10	5345-476D041	CAP, MINI ELE 47 $\mu$ /25V	543	C273	5361-473ZF	CAP, CER .047 $\mu$
718	C12	5345-476D041	CAP, MINI ELE 47 $\mu$ /25V	546	C276	5359-5115851	CAP, PPP 510p
718	C13	5345-476D041	CAP, MINI ELE 47 $\mu$ /25V	483	C281	5345-474F041	CAP, MINI ELE .47 $\mu$ /50V
048C	C51	5361-223ZF	CAP, CER .022 $\mu$ <b>IB BB</b>	417	C282	5361-223Z921	CAP, CER .022 $\mu$
048C	C52	5361-223ZF	CAP, CER .022 $\mu$ <b>IB BB</b>	417	C283	5361-223Z921	CAP, CER .022 $\mu$
044C	C101	5361-180JCH	CAP, CER 18p <b>IB BB</b>	605	C301	5354-473K1HM	CAP, MYL .047 $\mu$
417	C201	5361-223Z921	CAP, CER .022 $\mu$	593	C302	5345-224F0951	CAP, MINI ELE .22 $\mu$ /50V
417	C202	5361-223Z921	CAP, CER .022 $\mu$	594	C303	5345-474F0951	CAP, MINI ELE .47 $\mu$ /50V
417	C203	5361-223Z921	CAP, CER .022 $\mu$	595	C304	5345-105F041	CAP, MINI ELE 1 $\mu$ /50V
417	C204	5361-223Z921	CAP, CER .022 $\mu$	595	C305	5345-105F041	CAP, MINI ELE 1 $\mu$ /50V
417	C205	5361-223Z921	CAP, CER .022 $\mu$	606	C306	5361-103M920	CAP, CER .01 $\mu$
417	C206	5361-223Z921	CAP, CER .022 $\mu$	596	C307	5345-476D041	CAP, MINI ELE 47 $\mu$ /25V
417	C207	5361-103ZF	CAP, CER .01 $\mu$ <b>BK</b>	596	C308	5345-476D041	CAP, MINI ELE 47 $\mu$ /25V
417	C208	5361-223Z921	CAP, CER .022 $\mu$	597	C309	5345-226D041	CAP, MINI ELE .22 $\mu$ /25V
417	C209	5361-223Z921	CAP, CER .022 $\mu$	597	C310	5345-226D041	CAP, MINI ELE 22 $\mu$ /25V
417	C210	5361-223Z921	CAP, CER .022 $\mu$	601	C311	5359-4715851	CAP, PPP 470p <b>BK</b>
417	C211	5361-223Z921	CAP, CER .022 $\mu$	601C	C311	5359-2715851	CAP, PPP 270p <b>IB BB</b>
417	C212	5361-223Z921	CAP, CER .022 $\mu$	601	C312	5359-4715851	CAP, PPP 470p <b>BK</b>
417	C213	5361-223Z921	CAP, CER .022 $\mu$	601C	C312	5359-2715851	CAP, PPP 270p <b>IB BB</b>
420	C214	5359-1015851	CAP, PPP 100p	602	C313	5359-2715851	CAP, PPP 270p
413	C215	5345-105F041	CAP, MINI ELE 1 $\mu$ /50V	598	C314	5345-474F041	CAP, MINI ELE .47 $\mu$ /50V
414	C216	5345-227C041	CAP, MINI ELE 220 $\mu$ /16V	598	C315	5345-474F041	CAP, MINI ELE .47 $\mu$ /50V
418	C217	5361-103M920	CAP, CER .01 $\mu$	606	C316	5361-103M920	CAP, CER .01 $\mu$
419	C218	5361-473ZF	CAP, CER .047 $\mu$	600	C317	5359-1525851	CAP, PPP 1500p
417	C219	5361-223Z921	CAP, CER .022 $\mu$	600	C318	5359-1525851	CAP, PPP 1500p
417	C220	5361-223Z921	CAP, CER .022 $\mu$	600	C319	5359-1525851	CAP, PPP 1500p
419	C221	5361-473ZF	CAP, CER .047 $\mu$	600	C320	5359-1525851	CAP, PPP 1500p
414	C222	5345-227C041	CAP, MINI ELE 220 $\mu$ /16V	604	C321	5359-3025851	CAP, PPP 3000p
480	C223	5361-220JUU	CAP, CER 22p	604	C322	5359-3025851	CAP, PPP 3000p
473	C229	5361-223Z921	CAP, CER .022 $\mu$	603	C323	5359-1025851	CAP, PPP 1000p
473	C230	5361-223Z921	CAP, CER .022 $\mu$	603	C324	5359-1025851	CAP, PPP 1000p
473	C231	5361-223Z921	CAP, CER .022 $\mu$	599	C325	5345-225F041	CAP, MINI ELE 2.2 $\mu$ /50V
473	C232	5361-223Z921	CAP, CER .022 $\mu$	599	C326	5345-225F041	CAP, MINI ELE 2.2 $\mu$ /50V
473	C233	5361-223Z921	CAP, CER .022 $\mu$	609	C327	5361-223Z921	CAP, CER .022 $\mu$
482	C234	5359-2215851	CAP, PPP 220p	599	C329	5345-225F041	CAP, MINI ELE 2.2 $\mu$ /50V
475	C235	5361-101K918	CAP, CER 100p	599	C330	5345-225F041	CAP, MINI ELE 2.2 $\mu$ /50V
474	C236	5361-473ZF	CAP, CER .047 $\mu$	609	C331	5361-223Z921	CAP, CER .022 $\mu$
481	C237	5359-4725851	CAP, PPP 4700p	608	C350	5361-271K918	CAP, CER 270p <b>BK</b>
473	C238	5361-223Z921	CAP, CER .022 $\mu$	661	C701	5345-476D041	CAP, MINI ELE 47 $\mu$ /25V
473	C239	5361-223Z921	CAP, CER .022 $\mu$	662	C702	5350-S010Z473	CAP, SPE .047
473	C240	5361-223Z921	CAP, CER .022 $\mu$	667	C703	5361-300JCH	CAP, CER 30p
473	C241	5361-223Z921	CAP, CER .022 $\mu$	667	C704	5361-300JCH	CAP, CER 30p
473	C242	5361-223Z921	CAP, CER .022 $\mu$	659	C705	5345-225F041	CAP, MINI ELE 2.2 $\mu$ /50V
473	C243	5361-223Z921	CAP, CER .022 $\mu$	661	C706	5345-476D041	CAP, MINI ELE 47 $\mu$ /25V
473	C244	5361-223Z921	CAP, CER .022 $\mu$	669	C707	5361-102K918	CAP, CER 1000p
473	C245	5361-223Z921	CAP, CER .022 $\mu$	668	C708	5361-223Z921	CAP, CER .022 $\mu$
474	C246	5361-473ZF	CAP, CER .047 $\mu$	661	C709	5345-476D041	CAP, MINI ELE 47 $\mu$ /25V
477	C247	5361-121K918	CAP, CER 120p	661	C710	5345-476D041	CAP, MINI ELE 47 $\mu$ /25V
473	C248	5361-223Z921	CAP, CER .022 $\mu$	660	C711	5345-106F041	CAP, MINI ELE 10 $\mu$ /50V
479	C249	5361-180JUU	CAP, CER 18p	663	C712	5345-227C041	CAP, MINI ELE 220 $\mu$ /16V
479	C250	5361-180JUU	CAP, CER 18p	664	C713	5345-684F0951	CAP, MINI ELE .68 $\mu$ /50V
543	C251	5361-473ZF	CAP, CER .047 $\mu$	665	C714	5354-473K1HM	CAP, MYL .047 $\mu$
542	C252	5361-102K918	CAP, CER 1000p	668	C715	5361-223Z921	CAP, CER .022 $\mu$
543	C254	5361-473ZF	CAP, CER .047 $\mu$	661	C716	5345-476D041	CAP, MINI ELE 47 $\mu$ /25V
541	C255	5361-223Z921	CAP, CER .022 $\mu$	661	C717	5345-476D041	CAP, MINI ELE 47 $\mu$ /25V
541	C256	5361-223Z921	CAP, CER .022 $\mu$	668	C720	5361-223Z921	CAP, CER .022 $\mu$
535	C257	5345-106F041	CAP, MINI ELE 10 $\mu$ /50V	660	C721	5345-106F041	CAP, MINI ELE 10 $\mu$ /50V
541	C258	5361-223Z921	CAP, CER .022 $\mu$	670	C722	5345-107D041	CAP, MINI ELE 100 $\mu$ /25V
545	C260	5361-180JPH	CAP, CER 18p	666	C723	5345-475F041	CAP, MINI ELE 4.7 $\mu$ /50V
547	C261	5359-4715851	CAP, PPP 470p	666	C724	5345-475F041	CAP, MINI ELE 4.7 $\mu$ /50V
543	C262	5361-473ZF	CAP, CER .047 $\mu$	659	C725	5345-225F041	CAP, MINI ELE 2.2 $\mu$ /50V
536	C263	5345-475F041	CAP, MINI ELE 4.7 $\mu$ /50V	<b>RESISTORS</b>			
536	C264	5345-475F041	CAP, MINI ELE 4.7 $\mu$ /50V	725	R3	5135-272522	RES, CBN 1/2P 2.7K
544	C265	5361-103M920	CAP, CER .01 $\mu$	726	R4	5135-101522	RES, CBN 1/2P 100
540	C266	5361-472K918	CAP, CER 4700p	726	R5	5135-101522	RES, CBN 1/2P 100
				730	$\Delta$ R6	5102-2R25116	RES, FUSE 2.2
				727	R7	5135-331522	RES, CBN 1/2P 330
				728	R8	5135-105522	RES, CBN 1/2P 1M

Ser. No.	Ref. No.	Part No.	Description	Ser. No.	Ref. No.	Part No.	Description
729	R9	5135-102522	RES, CBN 1/2P 1K	564	R277	5135-473522	RES, CBN 1/2P 47K
728	R11	5135-102522	RES, CBN 1/2P 1K	557	R278	5135-223522	RES, CBN 1/2P 22K
695	△R12	5102-3304715	RES, FUSE 33	565	R279	5135-822522	RES, CBN 1/2P 8.2K
726	R13	5135-101522	RES, CBN 1/2P 100	551	R280	5232-223J16P	RES, CBN 1/6P 22K
423	R201	5135-391522	RES, CBN 1/2P 390	439	R281	5135-104522	RES, CBN 1/2P 100K
424	R202	5135-102522	RES, CBN 1/2P 1K	505	R282	5135-103522	RES, CBN 1/2P 10K
425	R203	5135-154522	RES, CBN 1/2P 150K	494	R283	5135-562522	RES, CBN 1/2P 5.6K
423	R204	5135-391522	RES, CBN 1/2P 390	493	R285	5135-104522	RES, CBN 1/2P 100K
426	R205	5135-101522	RES, CBN 1/2P 100	493	R286	5135-104522	RES, CBN 1/2P 100K
427	R206	5135-150522	RES, CBN 1/2P 15 <b>BK</b>	501	R287	5232-103J16P	RES, CBN 1/6P 10K
427C	R206	5135-220522	RES, CBN 1/2P 22 <b>IB</b> <b>BB</b>	441	R291	5232-154J16P	RES, CBN 1/6P 150K
428	R207	5135-222522	RES, CBN 1/2P 2.2K	442	R292	5232-104J16P	RES, CBN 1/6P 100K
423	R208	5135-391522	RES, CBN 1/2P 390	443	R293	5232-102J16P	RES, CBN 1/6P 1K
424	R209	5135-102522	RES, CBN 1/2P 1K	438	R294	5135-472522	RES, CBN 1/2P 4.7K
425	R210	5135-154522	RES, CBN 1/2P 150K	611	R301	5135-472522	RES, CBN 1/2P 4.7K
423	R211	5135-391522	RES, CBN 1/2P 390	050C	R302	5232-473J16P	RES, CBN 1/6P 47K <b>IB</b> <b>BB</b>
426	R212	5135-101522	RES, CBN 1/2P 100	612	R303	5135-103522	RES, CBN 1/2P 10K
429	R213	5135-220522	RES, CBN 1/2P 22	612	R304	5135-103522	RES, CBN 1/2P 10K
428	R214	5135-222522	RES, CBN 1/2P 2.2K	613	R305	5135-154522	RES, CBN 1/2P 150K <b>BK</b>
428	R215	5135-222522	RES, CBN 1/2P 2.2K	613C	R305	5134-184522	RES, CBN 1/2P 180K <b>IB</b> <b>BB</b>
428	R216	5135-222522	RES, CBN 1/2P 2.2K	613	R306	5135-154522	RES, CBN 1/2P 150K <b>BK</b>
428	R217	5135-222522	RES, CBN 1/2P 2.2K	613C	R306	5134-184522	RES, CBN 1/2P 180K <b>IB</b> <b>BB</b>
431	R218	5135-471522	RES, CBN 1/2P 470	614	R307	5135-124522	RES, CBN 1/2P 120K
430	R219	5135-562522	RES, CBN 1/2P 5.6K	614	R308	5135-124522	RES, CBN 1/2P 120K
432	R220	5135-123522	RES, CBN 1/2P 12K <b>BK</b>	615	R309	5135-222522	RES, CBN 1/2P 2.2K
432C	R220	5135-223522	RES, CBN 1/2P 22K <b>IB</b> <b>BB</b>	615	R310	5135-222522	RES, CBN 1/2P 2.2K
434	R222	5135-103522	RES, CBN 1/2P 10K	612	R311	5135-103522	RES, CBN 1/2P 10K
435	R223	5135-683522	RES, CBN 1/2P 68K	612	R312	5135-103522	RES, CBN 1/2P 10K
436	R224	5135-223522	RES, CBN 1/2P 22K	616	R313	5135-272522	RES, CBN 1/2P 2.7K
438	R225	5135-472522	RES, CBN 1/2P 4.7K	616	R314	5135-272522	RES, CBN 1/2P 2.7K
428	R226	5135-222522	RES, CBN 1/2P 2.2K	616	R315	5135-272522	RES, CBN 1/2P 2.7K
434	R227	5135-103522	RES, CBN 1/2P 10K	616	R316	5135-272522	RES, CBN 1/2P 2.7K
485	R231	5135-391522	RES, CBN 1/2P 390	626	R317	5135-132522	RES, CBN 1/2P 1.3K
486	R232	5135-102522	RES, CBN 1/2P 1K	626	R318	5135-132522	RES, CBN 1/2P 1.3K
487	R233	5135-154522	RES, CBN 1/2P 150K	614	R319	5135-124522	RES, CBN 1/2P 120K
485	R234	5135-391522	RES, CBN 1/2P 390	614	R320	5135-124522	RES, CBN 1/4P 120K
488	R235	5135-101522	RES, CBN 1/2P 100	618	R321	5135-224522	RES, CBN 1/2P 220K
489	R236	5135-100522	RES, CBN 1/2P 10	618	R322	5135-224522	RES, CBN 1/2P 220K
490	R237	5135-331522	RES, CBN 1/2P 330	619	R323	5135-182522	RES, CBN 1/2P 1.8K
491	R238	5135-472522	RES, CBN 1/2P 4.7K	619	R324	5135-182522	RES, CBN 1/2P 1.8K
492	R239	5135-223522	RES, CBN 1/2P 22K	620	R325	5135-470522	RES, CBN 1/2P 47
495	R240	5232-332J16P	RES, CBN 1/6P 3.3K	620	R326	5135-470522	RES, CBN 1/2P 47
496	R241	5232-102J16P	RES, CBN 1/6P 1K	621	R327	5135-121522	RES, CBN 1/2P 120
497	R242	5232-223J16P	RES, CBN 1/6P 22K	616	R329	5135-272522	RES, CBN 1/2P 2.7K
493	R243	5135-104522	RES, CBN 1/2P 100K	616	R330	5135-272522	RES, CBN 1/2P 2.7K
493	R244	5135-104522	RES, CBN 1/2P 100K	623	R331	5135-242522	RES, CBN 1/2P 2.4K
496	R245	5232-102J16P	RES, CBN 1/6P 1K	623	R332	5135-242522	RES, CBN 1/2P 2.4K
493	R246	5135-104522	RES, CBN 1/2P 100K	622	R333	5135-152522	RES, CBN 1/2P 1.5K
498	R247	5232-473J16P	RES, CBN 1/6P 47K	622	R334	5135-152522	RES, CBN 1/2P 1.5K
498	R248	5232-473J16P	RES, CBN 1/6P 47K	629	R337	5232-103J16P	RES, CBN 1/6P 10K
499	R249	5232-472J16P	RES, CBN 1/6P 4.7K	629	R338	5232-103J16P	RES, CBN 1/6P 10K
490	R250	5135-331522	RES, CBN 1/2P 330	612	R341	5135-103522	RES, CBN 1/2P 10K
563	R251	5135-471522	RES, CBN 1/2P 470	612	R342	5135-103522	RES, CBN 1/2P 10K
554	R254	5135-182522	RES, CBN 1/2P 1.8K	624	R343	5135-104522	RES, CBN 1/2P 100K
556	R255	5135-683522	RES, CBN 1/2P 68K	625	R344	5135-105522	RES, CBN 1/2P 1M
557	R256	5135-223522	RES, CBN 1/2P 22K	617	R345	5135-122522	RES, CBN 1/2P 1.2K
558	R257	5135-122522	RES, CBN 1/2P 1.2K	045B	R347	5232-102J16P	RES, CBN 1/6P 1K <b>IB</b> <b>BB</b>
555	R258	5135-102522	RES, CBN 1/2P 1K	045B	R348	5232-102J16P	RES, CBN 1/6P 1K <b>IB</b> <b>BB</b>
559	R259	5135-272522	RES, CBN 1/2P 2.7K	628	R350	5135-102522	RES, CBN 1/2P 1K <b>BK</b>
560	R260	5135-820522	RES, CBN 1/2P 82	671	R701	5232-472J16P	RES, CBN 1/6P 4.7K
561	R261	5135-103522	RES, CBN 1/2P 10K	672	R702	5232-222J16P	RES, CBN 1/6P 2.2K
561	R262	5135-103522	RES, CBN 1/2P 10K	672	R703	5232-222J16P	RES, CBN 1/6P 2.2K
562	R263	5135-104522	RES, CBN 1/2P 100K	672	R704	5232-222J16P	RES, CBN 1/6P 2.2K
562	R264	5135-104522	RES, CBN 1/2P 100K	672	R705	5232-222J16P	RES, CBN 1/6P 2.2K
559	R265	5135-223522	RES, CBN 1/2P 22K	672	R706	5232-222J16P	RES, CBN 1/6P 2.2K
561	R266	5135-103522	RES, CBN 1/2P 10K	672	R707	5232-222J16P	RES, CBN 1/6P 2.2K
563	R267	5135-471522	RES, CBN 1/2P 470	672	R708	5232-222J16P	RES, CBN 1/6P 2.2K
553	R269	5135-103522	RES, CBN 1/2P 10K	672	R709	5232-222J16P	RES, CBN 1/6P 2.2K
562	R270	5135-104522	RES, CBN 1/2P 100K	672	R710	5232-222J16P	RES, CBN 1/6P 2.2K
564	R271	5135-473522	RES, CBN 1/2P 47K	672	R711	5232-222J16P	RES, CBN 1/6P 2.2K
499	R272	5232-472J16P	RES, CBN 1/6P 4.7K	672	R712	5232-222J16P	RES, CBN 1/6P 2.2K
500	R273	5232-681J16P	RES, CBN 1/6P 680	672	R713	5232-222J16P	RES, CBN 1/6P 2.2K
504	R274	5232-101J16P	RES, CBN 1/6P 100	672	R714	5232-222J16P	RES, CBN 1/6P 2.2K
498	R275	5232-473J16P	RES, CBN 1/6P 47K	672	R715	5232-222J16P	RES, CBN 1/6P 2.2K
498	R276	5232-473J16P	RES, CBN 1/6P 47K				

Ser. No.	Ref. No.	Part No.	Description	Ser. No.	Ref. No.	Part No.	Description
672	R716	5232-222J16P	RES, CBN 1/6P 2.2K				
681	R717	5135-104522	RES, CBN 1/2P 100K				
682	R718	5135-102522	RES, CBN 1/2P 1K				
683	R719	5135-472522	RES, CBN 1/2P 4.7K				
684	R720	5135-222522	RES, CBN 1/2P 2.2K				
684	R721	5135-222522	RES, CBN 1/2P 2.2K				
684	R722	5135-222522	RES, CBN 1/2P 2.2K				
684	R723	5135-222522	RES, CBN 1/2P 2.2K				
699	R724	5171-S010J470	RES, MTL 1P 47				
685	R725	5135-103522	RES, CBN 1/2P 10K				
685	R726	5135-103522	RES, CBN 1/2P 10K				
685	R727	5135-103522	RES, CBN 1/2P 10K				
685	R729	5135-103522	RES, CBN 1/2P 10K				
685	R730	5135-103522	RES, CBN 1/2P 10K				
682	R731	5135-102522	RES, CBN 1/2P 1K				
682	R732	5135-102522	RES, CBN 1/2P 1K				
687	R733	5135-222522	RES, CBN 1/2P 2.2K				
687	R734	5135-222522	RES, CBN 1/2P 2.2K				
688	R735	5135-100522	RES, CBN 1/2P 10				
686	R736	5135-473522	RES, CBN 1/2P 47K				
686	R737	5135-473522	RES, CBN 1/2P 47K				
686	R738	5135-473522	RES, CBN 1/2P 47K				
685	R739	5135-103522	RES, CBN 1/2P 10K				
686	R740	5135-473522	RES, CBN 1/2P 47K				
686	R741	5135-473522	RES, CBN 1/2P 47K				
680	R742	5135-223522	RES, CBN 1/2P 22K				
685	R744	5135-103522	RES, CBN 1/2P 10K				
681	R745	5135-104522	RES, CBN 1/2P 100K				
679	R746	5232-273J16P	RES, CBN 1/6P 27K				
679	R747	5232-273J16P	RES, CBN 1/6P 27K				
680	R748	5135-223522	RES, CBN 1/2P 22K				
680	R749	5135-223522	RES, CBN 1/2P 22K				
680	R750	5135-223522	RES, CBN 1/2P 22K				
687	R751	5135-222522	RES, CBN 1/2P 2.2K				
687	R752	5135-222522	RES, CBN 1/2P 2.2K				
687	R753	5135-222522	RES, CBN 1/2P 2.2K				
687	R754	5135-222522	RES, CBN 1/2P 2.2K				
687	R755	5135-222522	RES, CBN 1/2P 2.2K				
687	R756	5135-222522	RES, CBN 1/2P 2.2K				
687	R757	5135-222522	RES, CBN 1/2P 2.2K				
687	R758	5135-222522	RES, CBN 1/2P 2.2K				
687	R759	5135-222522	RES, CBN 1/2P 2.2K				
676	R760	5232-183J16P	RES, CBN 1/6P 18K				
677	R761	5232-513J16P	RES, CBN 1/6P 51K				
678	R762	5232-154J16P	RES, CBN 1/6P 150K				
673	R763	5232-103J16P	RES, CBN 1/6P 10K				
694	R764	5135-333522	RES, CBN 1/2P 33K				
686	R765	5135-473522	RES, CBN 1/2P 47K				
700	R766	5135-271522	RES, CBN 1/2P 270				
686	R767	5135-473522	RES, CBN 1/2P 47K				
690	R768	5135-470522	RES, CBN 1/2P 47				
674	R769	5232-102J16P	RES, CBN 1/6P 1K				
682	R770	5135-102522	RES, CBN 1/2P 1K				
685	R771	5135-103522	RES, CBN 1/2P 10K				
672	R772	5232-222J16P	RES, CBN 1/6P 2.2K				
675	R773	5232-473J16P	RES, CBN 1/6P 47K				
675	R774	5232-473J16P	RES, CBN 1/6P 47K				
682	R775	5135-102522	RES, CBN 1/2P 1K				
682	R776	5135-102522	RES, CBN 1/2P 1K				
690	R777	5135-470522	RES, CBN 1/2P 47				
696	R778	5135-101522	RES, CBN 1/2P 100				
680	R781	5135-223522	RES, CBN 1/2P 22K				
685	R782	5135-103522	RES, CBN 1/2P 10K				
686	R783	5135-473522	RES, CBN 1/2P 47K				
692	R784	5135-562522	RES, CBN 1/2P 5.6K				
682	R785	5135-102522	RES, CBN 1/2P 1K				
506	R787	5135-473522	RES, CBN 1/2P 47K				
506	R788	5135-473522	RES, CBN 1/2P 47K				
691	R789	5135-332522	RES, CBN 1/2P 3.3K				
679	R790	5232-273J16P	RES, CBN 1/6P 27K				
682	R791	5135-102522	RES, CBN 1/2P 1K				
682	R792	5135-102522	RES, CBN 1/2P 1K				
685	R793	5135-103522	RES, CBN 1/2P 10K				
685	R794	5135-103522	RES, CBN 1/2P 10K				
685	R795	5135-103522	RES, CBN 1/2P 10K				
<b>INTEGRATED CIRCUITS</b>							
				404	IC201	5652-LA1235	IC, MONO
				461	IC202	5652-LA1235	IC, MONO
				521	IC251	5652-LA1245	IC, MONO
				581	IC301	5653-LA3450	IC, LINEAR
				641	IC701	5654-T9301-20	IC, DIGITAL
				642	IC702	5654-TC9227P	IC, DIGITAL
				643	IC703	5654-AK93C46	IC, DIGITAL
				644	IC704	5654-TC9173P	IC, DIGITAL
				646	IC705	5652-BA6124	IC, MONO
<b>TRANSISTORS</b>							
				704	Q2	5612-1375	XISTOR, PNP A
				703	Q3	5613-2320(F)	XISTOR, NPN R
				701	Q4	5614-667(C)	XISTOR, NPN A
				701	Q5	5614-667(C)	XISTOR, NPN A
				406	Q201	5613-2058(N)	XISTOR, NPN R
				406	Q202	5613-2058(N)	XISTOR, NPN R
				463	Q203	5613-2058(N)	XISTOR, NPN R
				405	Q204	5613-2320(F)	XISTOR, NPN R
				465	Q205	5611-999(F)	XISTOR, PNP R
				464	Q206	5613-2320(F)	XISTOR, NPN R
				463	Q207	5613-2058(N)	XISTOR, NPN R
				463	Q208	5613-2058(N)	XISTOR, NPN R
				466	Q209	5613-RN1203	XISTOR, NPN R
				464	Q210	5613-2320(F)	XISTOR, NPN R
				466	Q212	5613-RN1203	XISTOR, NPN R
				522	Q252	5613-2320(F)	XISTOR, NPN R
				522	Q253	5613-2320(F)	XISTOR, NPN R
				584	Q301	5613-RN1203	XISTOR, NPN R
				585	Q302	5611-RN2203	XISTOR, PNP R
				586	Q303	5613-2320(F)	XISTOR, NPN R
				586	Q304	5613-2320(F)	XISTOR, NPN R
				587	Q305	5611-999(F)	XISTOR, PNP R
				587	Q306	5611-999(F)	XISTOR, PNP R
				587	Q307	5611-999(F)	XISTOR, PNP R
				587	Q308	5611-999(F)	XISTOR, PNP R
				583	Q311	5614-1450(T)	XISTOR, NPN A
				583	Q312	5614-1450(T)	XISTOR, NPN A
				588	Q313	5616-2SK381(D) OR (E)	FET, N-CH
				647	Q701	5613-2240(BL)	XISTOR, NPN R
				648	Q702	5613-2320(F)	XISTOR, NPN R
				648	Q703	5613-2320(F)	XISTOR, NPN R
				649	Q705	5613-RN1203	XISTOR, NPN R
				649	Q706	5613-RN1203	XISTOR, NPN R
				648	Q707	5613-2320(F)	XISTOR, NPN R
				649	Q708	5613-RN1203	XISTOR, NPN R
				651	Q709	5611-RN2203	XISTOR, PNP R
				649	Q710	5613-RN1203	XISTOR, NPN R
				651	Q711	5611-RN2203	XISTOR, PNP R
				649	Q712	5613-RN1203	XISTOR, NPN R
				648	Q713	5613-2320(F)	XISTOR, NPN R
				649	Q714	5613-RN1203	XISTOR, NPN R
				648	Q715	5613-2320(F)	XISTOR, NPN R
				649	Q716	5613-RN1203	XISTOR, NPN R
				649	Q717	5613-RN1203	XISTOR, NPN R
				649	Q718	5613-RN1203	XISTOR, NPN R
				651	Q720	5611-RN2203	XISTOR, PNP R
				649	Q721	5613-RN1203	XISTOR, NPN R
				649	Q722	5613-RN1203	XISTOR, NPN R
				649	Q723	5613-RN1203	XISTOR, NPN R
				649	Q724	5613-RN1203	XISTOR, NPN R
				649	Q725	5613-RN1203	XISTOR, NPN R
				649	Q726	5613-RN1203	XISTOR, NPN R
				649	Q727	5613-RN1203	XISTOR, NPN R
				649	Q728	5613-RN1203	XISTOR, NPN R
				649	Q729	5613-RN1203	XISTOR, NPN R
				649	Q730	5613-RN1203	XISTOR, NPN R
				649	Q731	5613-RN1203	XISTOR, NPN R
				649	Q732	5613-RN1203	XISTOR, NPN R
				649	Q733	5613-RN1203	XISTOR, NPN R
				649	Q734	5613-RN1203	XISTOR, NPN R
				649	Q735	5613-RN1203	XISTOR, NPN R
				649	Q736	5613-RN1203	XISTOR, NPN R
				650	Q739	5613-RN1203	XISTOR, NPN R

Ser. No.	Ref. No.	Part No.	Description
650	Q740	5613-RN1203	XISTOR, NPN R
651	Q741	5611-RN2203	XISTOR, PNP R
651	Q744	5611-RN2203	XISTOR, PNP R
652	Q745	5611-999(F)	XISTOR, PNP R
<b>DIODES</b>			
705	D3	5632-S5566B	DIODE, RECT
705	D4	5632-S5566B	DIODE, RECT
705	D5	5632-S5566B	DIODE, RECT
705	D6	5632-S5566B	DIODE, RECT
708	D7	5635-HZ12C2L	DIODE, ZENER
709	D8	5635-HZ9A1L	DIODE, ZENER
710	D9	5631-1S2473	DIODE, DET
711	D10	5631-1SS133	DIODE, DET
712	D11	5635-HZ3B-2	DIODE, ZENER
705	D12	5632-S5566B	DIODE, RECT
705	D13	5632-S5566B	DIODE, RECT
713	D14	5635-HZ6C2L	DIODE, ZENER
710	D15	5631-1S2473	DIODE, DET
710	D16	5631-1S2473	DIODE, DET
471	D201	5631-1SS133	DIODE, DET
471	D202	5631-1SS133	DIODE, DET
471	D203	5631-1SS133	DIODE, DET
471	D204	5631-1SS133	DIODE, DET
411	D205	5631-1SS133	DIODE, DET
471	D206	5631-1SS133	DIODE, DET
471	D207	5631-1SS133	DIODE, DET
467	D208	5633-1SV103	DIODE, CAP
467	D209	5633-1SV103	DIODE, CAP
471	D210	5631-1SS133	DIODE, DET
411	D211	5631-1SS133	DIODE, DET
471	D212	5631-1SS133	DIODE, DET
525	D251	5633-1SV149	DIODE, CAP
525	D252	5633-1SV149	DIODE, CAP
462	D253	5631-1S2473	DIODE, DET
524	D254	5631-1S2473	DIODE, DET
589	D301	5631-1S2473	DIODE, DET
589	D302	5631-1S2473	DIODE, DET
653	D701	5631-1S2473	DIODE, DET
653	D702	5631-1S2473	DIODE, DET
653	D703	5631-1S2473	DIODE, DET
653	D704	5631-1S2473	DIODE, DET
653	D705	5631-1S2473	DIODE, DET
653	D706	5631-1S2473	DIODE, DET
653	D707	5631-1S2473	DIODE, DET
654	D708	5631-1SS133	DIODE, DET
654	D709	5631-1SS133	DIODE, DET
654	D710	5631-1SS133	DIODE, DET
654	D711	5631-1SS133	DIODE, DET
654	D712	5631-1SS133	DIODE, DET
654	D714	5631-1SS133	DIODE, DET <b>BK</b>
654	D715	5631-1SS133	DIODE, DET <b>BK</b>
654	D716	5631-1SS133	DIODE, DET
654	D718	5631-1SS133	DIODE, DET
653	D720	5631-1S2473	DIODE, DET
654	D721	5631-1SS133	DIODE, DET
653	D722	5631-1S2473	DIODE, DET
653	D723	5631-1S2473	DIODE, DET
653	D724	5631-1S2473	DIODE, DET
653	D725	5631-1S2473	DIODE, DET
653	D726	5631-1S2473	DIODE, DET
653	D727	5631-1S2473	DIODE, DET
654	D728	5631-1SS133	DIODE, DET
653	D729	5631-1S2473	DIODE, DET
653	D730	5631-1S2473	DIODE, DET
653	D733	5631-1S2473	DIODE, DET
<b>CONTROLS</b>			
407	VR201	5101-50301934	RES, SEMI FIX 50K
408	VR202	5101-20301934	RES, SEMI FIX 20K
468	VR203	5101-50301934	RES, SEMI FIX 50K
534	VR251	5101-50301934	RES, SEMI FIX 50K
591	VR301	5101-50401934	RES, SEMI FIX 500K
592	VR302	5101-50301934	RES, SEMI FIX 50K

Ser. No.	Ref. No.	Part No.	Description
<b>COILS</b>			
402	L101	5995-2R2J107	COIL W/CORE
043C	L103	5214-78	LC COMPOSITE <b>IB</b> <b>BB</b>
402	L201	5995-2R2J107	COIL W/CORE
529	L251	5552-70113	IFT, AM 7
530	L252	5932-70123	COIL CASE, 7
<b>TRANSFORMERS</b>			
410	T201	5573-10101	DISCRI 10
470	T202	5922-10901	OSC COIL, 7
527	T251	5933-S0102	COIL CASE, 10
528	T252	5922-00512	OSC COIL, 7
526	T253	5933-S1601	COIL CASE, 10
<b>MISCELLANEOUS</b>			
737	J101	4482-0133	PIN JACK, 2P
738	J102	4451-00184	JACK, 1P
738	J103	4451-00184	JACK, 1P
590	X301	5693-CSB456F1	OSC, CER
655	X701	5691-00720027	XTAL, OSC
409	CF201	5671-0151A113	FILTER, CER S <b>BK</b>
409C	CF201	5671-2036GKA	FILTER, CER S <b>IB</b> <b>BB</b>
409	CF202	5671-0151A113	FILTER, CER S <b>BK</b>
409C	CF202	5671-2036GKA	FILTER, CER S <b>IB</b> <b>BB</b>
472	CF203	5671-0011A106	FILTER, CER S
472	CF204	5671-0011A106	FILTER, CER S
042B	CF205	5671-0011A106	FILTER, CER S <b>IB</b> <b>BB</b>
531	CF251	5671-0161D451	FILTER, CER S
532	CF252	5671-7137C	FILTER, CER S
739	CN701A	4443-05501027	CONNECTOR
741	CN702A	4443-05501011	CONNECTOR
401	FE101	6114-00401	FM TUNER <b>BK</b>
401C	FE101	6114-00402	FM TUNER <b>IB</b> <b>BB</b>
697	JL701	4242-S0327201	JUMPER LEAD
698	JL702	4242-S0311171	JUMPER LEAD
049C	LUG1	4211-4	LUG <b>IB</b> <b>BB</b>
720	PH101	5624-0N3161	PHOTO COUPLER
656	RC701	5212-103J1003	R COMPOSITE
657	RC702	5212-103J0603	R COMPOSITE
751	RL101	4331-01201	RELAY, DC
469	TC201	5371-93	TRIMMER, 1P
533	TC251	5371-93	TRIMMER, 1P
749	TM101	4214-166	TERMINAL <b>BK</b>
749C	TM101	4214-167	TERMINAL <b>IB</b> <b>BB</b>
749	TM102	4214-166	TERMINAL <b>BK</b>
749C	TM102	4214-167	TERMINAL <b>IB</b> <b>BB</b>
750	TM103	4214-229	TERMINAL
736	CN101	4443-060185	CONNECTOR

**PCB-2 FRONT P.C. BOARD**

Ser. No.	Ref. No.	Part No.	Description
<b>RESISTORS</b>			
689	R796	5135-152522	RES, CBN 1/2P 1.5K
634	R797	5135-222522	RES, CBN 1/2P 2.2K
635	R798	5135-472522	RES, CBN 1/2P 4.7K
635	R799	5135-472522	RES, CBN 1/2P 4.7K
635	R800	5135-472522	RES, CBN 1/2P 4.7K
693	R801	5135-153522	RES, CBN 1/2P 15K
693	R802	5135-153522	RES, CBN 1/2P 15K
636	R803	5135-332522	RES, CBN 1/2P 3.3K
693	R804	5135-153522	RES, CBN 1/2P 15K
<b>INTEGRATED CIRCUITS</b>			
645	IC706	5654-TB2104F	IC, DIGITAL
645	IC707	5654-TB2104F	IC, DIGITAL
<b>TRANSISTORS</b>			
702	Q742	5613-RN1203	XISTOR, NPN R
633	Q743	5611-RN2203	XISTOR, PNP R
<b>MISCELLANEOUS</b>			
732	S11	4437-00603	SWITCH, PU-TC
732	S12	4437-00603	SWITCH, PU-TC
732	S13	4437-00603	SWITCH, PU-TC
732	S14	4437-00603	SWITCH, PU-TC
732	S15	4437-00603	SWITCH, PU-TC
732	S16	4437-00603	SWITCH, PU-TC

Ser. No.	Ref. No.	Part No.	Description
732	S17	4437-00603	SWITCH, PU-TC
732	S18	4437-00603	SWITCH, PU-TC
734	S19	4437-00604	SWITCH, PU-TC
734	S20	4437-00604	SWITCH, PU-TC
734	S21	4437-00604	SWITCH, PU-TC
734	S22	4437-00604	SWITCH, PU-TC
734	S23	4437-00604	SWITCH, PU-TC
734	S24	4437-00604	SWITCH, PU-TC
732	S25	4437-00603	SWITCH, PU-TC
732	S26	4437-00603	SWITCH, PU-TC
734	S27	4437-00604	SWITCH, PU-TC
734	S28	4437-00604	SWITCH, PU-TC
734	S29	4437-00604	SWITCH, PU-TC
734	S30	4437-00604	SWITCH, PU-TC
740	CN701B	4443-05401027	CONNECTOR
742	CN702B	4443-05401011	CONNECTOR
746	FL701	5722-053	TUBE DISPLAY
658	RC703	5212-153J0503	R COMPOSITE
658	RC704	5212-153J0503	R COMPOSITE
752	RCV701	6143-00801	RECEIV BLOCK

**PCB-3 POWER SUPPLY P.C. BOARD**

**CAPACITORS**

721	C1	5361-473ZF	CAP, CER .047 $\mu$
721	C2	5361-473ZF	CAP, CER .047 $\mu$
716	C3	5345-476D041	CAP, MINI ELE 47 $\mu$ /25V
716	C11	5345-476D041	CAP, MINI ELE 47 $\mu$ /25V

**RESISTORS**

723	$\Delta$ R1	5135-335522	RES, CBN 1/2P 3.3M <b>BK</b>
724	R2	5135-152522	RES, CBN 1/2P 1.5K
719	R10	5135-102522	RES, CBN 1/2P 1K
724	R14	5135-152522	RES, CBN 1/2P 1.5K

**DIODES**

706	$\Delta$ D1	5632-S5566B	DIODE, RECT
707	D2	5635-HZ6C2L	DIODE, ZENER
714	D17	5631-1S2473	XISTOR, DET

**TRANSFORMERS**

731	$\Delta$ T1	5584-S7701	XFORMER, POWER <b>BK</b>
731C	$\Delta$ T1	5584-S7702	XFORMER, POWER <b>IB</b> <b>BB</b>

**MISCELLANEOUS**

047C	$\Delta$ F1	5732-162030	FUSE <b>IB</b> <b>BB</b>
733	S1	4431-S1003102	SWITCH, PUSH
041C	$\Delta$ S2	4411-1047111	SWITCH, ROTARY <b>IB</b> <b>BB</b>
046C	$\Delta$ HF1	4472-0131	HOLDER, FUSE <b>IB</b> <b>BB</b>
046C	$\Delta$ HF2	4472-0131	HOLDER, FUSE <b>IB</b> <b>BB</b>
743	TM1	4214-122	TERMINAL
743	TM2	4214-122	TERMINAL
744	$\Delta$ TM106	4474-02701	SOCKET <b>BK</b>
735	JL101	4242-R0206800	JUMPER LEAD

Ser. No.	Ref. No.	Part No.	Description
----------	----------	----------	-------------

**ABBREVIATIONS IN PARTS LIST**

**CAPACITORS**

CAP, MINI ELE	: Electrolytic
CAP, CER	: Ceramic
CAP, PPP	: Polypropylene
CAP, MYL	: Mylar
CAP, MCA	: Mica
CAP, MINI BP	: Bipolar
CAP, ELE BP	: Electrolytic Bipolar
470 $\mu$	: 470 $\mu$ F
6800p	: 6800pF
.047 $\mu$	: 0.047 $\mu$ F

**RESISTORS**

RES, CBN 1/6P	: Carbon 1/6W
RES, FUSE	: Fuse
RES, CEM 5P	: Cement 5W
RES, MTL 1P	: Metal 1W
2.2K	: 2.2k $\Omega$
220	: 220 $\Omega$

**TRANSISTORS**

XISTOR	: Transistor
FET	: Field Effect Transistor

**CONTROLS**

RES, SEMI FIX	: Semi-fixed Resistor
---------------	-----------------------

**CHASSIS MISCELLANEOUS PARTS LIST**

**MISCELLANEOUS**

549	L1	5911-235	ANT COIL, BC
747	$\Delta$ P1	4161-71151	CORD W/PLUG <b>BK</b>
747B	$\Delta$ P1	4161-7256	CORD W/PLUG <b>IB</b>
747D	$\Delta$ P1	4161-04100	CORD W/PLUG <b>BB</b>
745		1398-015	ADAPTER, ANT <b>BK</b>
748		4161-71184	CORD W/PLUG, CONNECTION
754		6142-02702	CONT BLOCK
755		1397-6	T FEEDER ANT

**PACKAGE PARTS LIST**

021C	1756-06303	LABEL <b>IB</b> <b>BB</b>
022C	1756-03108	LABEL <b>IB</b>
022D	1756-03111	LABEL <b>BB</b>
023C	1111-J30235	OWNER GUIDE, ADDENDUM <b>IB</b> <b>BB</b>
024D	1111-J30319	OWNER GUIDE <b>BB</b>
025D	1756-08501	LABEL <b>BB</b>
111	1221-27703	CARTON BOX <b>BK</b>
111C	1221-27704	CARTON BOX <b>IB</b> <b>BB</b>
113	1222-7363	CUSHION
114	1222-7364	CUSHION
115	1223-R0120055	SOFT SHEET
116	1241-R0123350	POLYETHYLENE BAG
117	1241-C1493	POLYETHYLENE BAG
118	1111-J30321	OWNER GUIDE <b>BK</b>
118C	1111-J30322	OWNER GUIDE <b>IB</b>
119	1241-R0115300	POLYETHYLENE BAG
120	1113-717004	OWNER CARD <b>BK</b>
121	1119-047	ATTACH SHEET <b>BK</b>
122	1119-01201	ATTACH SHEET <b>BK</b>
123	1119-0137	ATTACH SHEET <b>BK</b>

**NOTE**



SAFETY RELATED COMPONENT. USE ONLY EXACT REPLACEMENT PART AS SPECIFIED.

IC BLOCK DIAGRAM

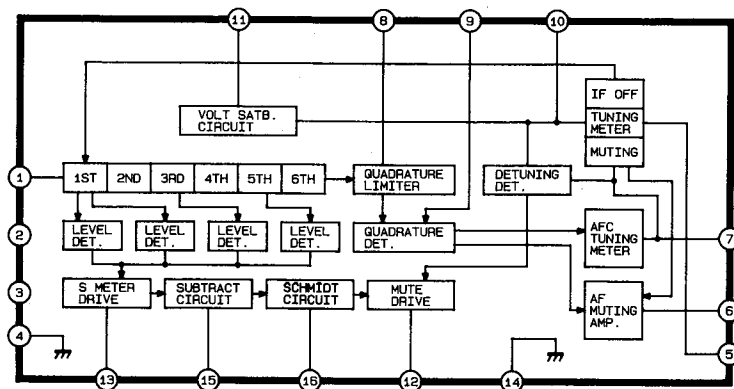

IC201, 202 : LA1235  
FM IF Amp.

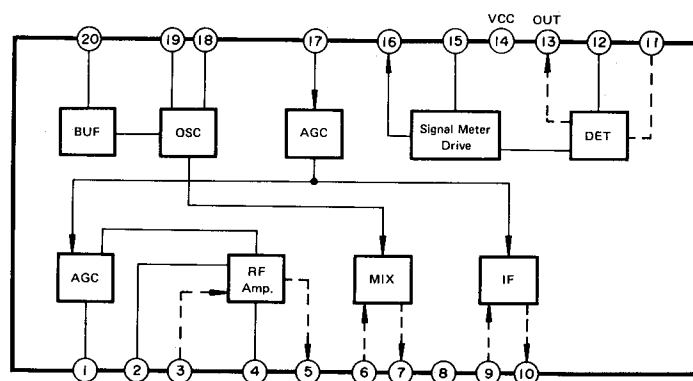

IC251 : LA1245  
AM Section

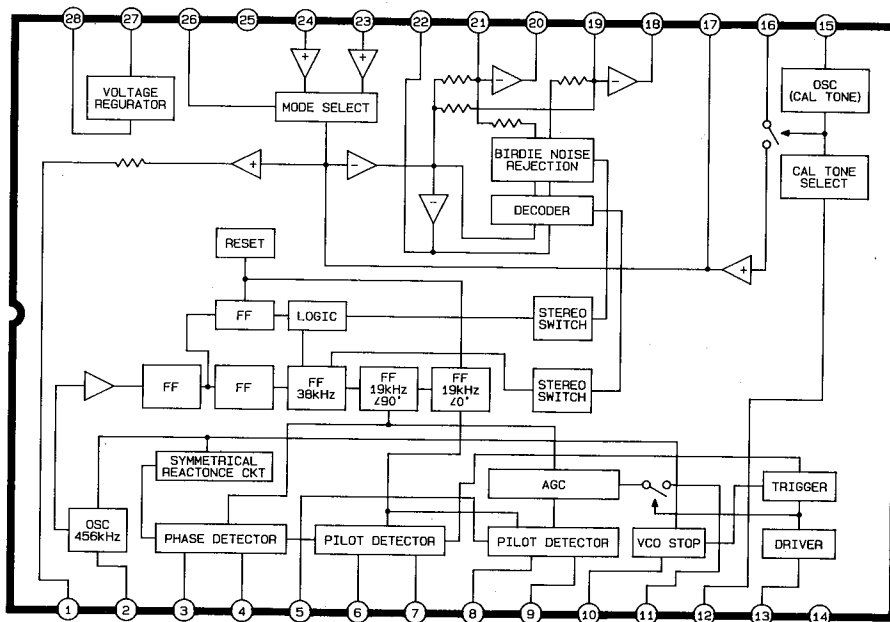

IC301 : LA3450  
FM PLL MPX



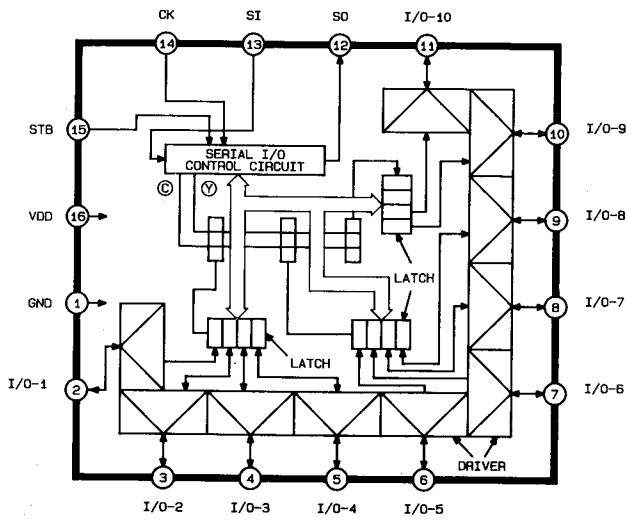

**IC704 : TC9173P  
Active Tracking  
System Controller**

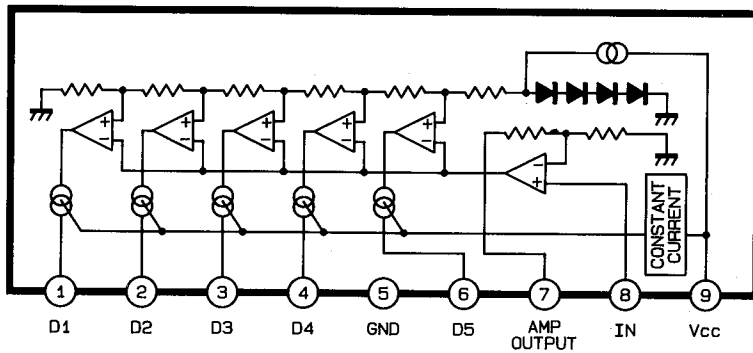

**IC705 : BA6124  
Signal Strength  
Indicator Driver**

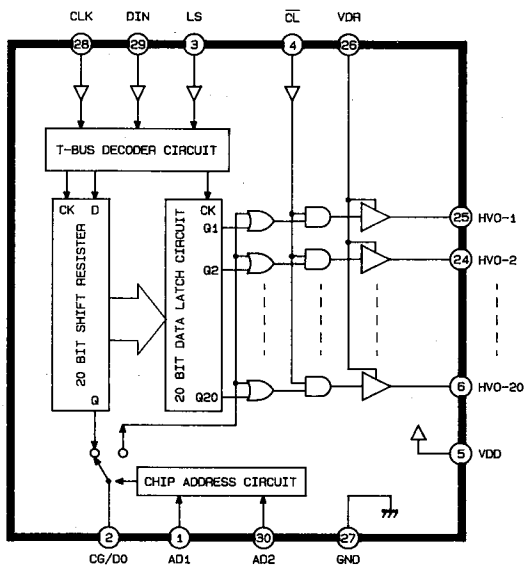

**IC706, 707 : TB2104F  
FL Tube Driver**



## IC TERMINAL FUNCTIONS

	Terminal number	Port name	Terminal code	I/O	Outline of functions
IC701	1	GND			GND pin
	2	K0		I	4-bit key input port
	3	K1		I	4-bit key input port
	4	K2		I	4-bit key input port
	5	K3		I	4-bit key input port
	6	D0		O	Digit output
	7	D1		O	Digit output
	8	D2		O	Digit output
	9	D3		O	Digit output
	10	D4		O	Digit output
	11	D5		O	Digit output
	12	D6		O	Digit output
	13	a		O	Segment output
	14	b		O	Segment output
	15	c		O	Segment output
	16	d		O	Segment output
	17	e		O	Segment output
	18	f		O	Segment output
	19	g		O	Segment output
	20	h		O	Segment output
	21	-VFL		I	Negative power terminal (4-bit key input port, digit output, segment output)
	22	P3-1		I/O	4-bit I/O port (3)
	23	P3-2		I/O	4-bit I/O port (3)
	24	P3-3		I/O	4-bit I/O port (3)
	25	P3-4		I/O	4-bit I/O port (3)
	26	P2-1		I/O	4-bit I/O port (2)
	27	P2-2		I/O	4-bit I/O port (2)
	28	P2-3		I/O	4-bit I/O port (2)
	29	P2-4		I/O	4-bit I/O port (2)
	30	P1-2		I/O	1-bit I/O port (1)
	31	MUTE		O	1-bit muting signal output port
	32	TEST		I	Test mode control input terminal

	Terminal number	Port name	Terminal code	I/O	Outline of functions
IC701	33	STB		O	Serial interface (stroke pulse output)
	34	CK		O	Serial interface (serial clock output)
	35	SO		O	Serial interface (serial data output)
	36	SI		I	Serial interface (serial data input)
	37	REF		O	Reference frequency signal output terminal
	38	$\overline{\text{INT}}$		I	Initialize input (system reset signal input terminal)
	39	$\overline{\text{INH}}$		I	Inhibit input (select signal input port of radio mode)
	40	$\overline{\text{XT}}$			Connect quartz oscillator
	41	XT			Connect quartz oscillator
	42	VDD		I	Power supply terminal
IC702	1	NC			Not connected
	2	REF		I	Reference frequency input
	3	SO		O	Serial I/O port (serial output)
	4	SI		I	Serial I/O port (serial input)
	5	CK		I	Serial I/O port (clock signal input)
	6	STB		I	Serial I/O port (stroke signal input)
	7	A-STP		I	Autostop signal input
	8	IFIN		I	IF signal input of IF counter detected autostop
	9	IN1		I	Input port
	10	OT1		O	Output port
	11	OT2		O	Output port
	12	OT3		O	Output port
	13	OT4		O	Output port
	14	OT5		O	Output port
	15	OT6		O	Output port
	16	DO2		O	Phase comparator output
	17	DO1		O	Phase comparator output
	18	TEST		I	Test mode control input
	19	AMIN		I	AM local oscillator (programmable counter input)
	20	GND			GND pin
	21	FMIN		I	FM local oscillator (pre scaler input)
	22	VDD		I	5V $\pm$ 10% power supply terminal

	Terminal number	Port name	Terminal code	I/O	Outline of functions
IC703	1	CS		I	Serial interface (chip select)
	2	SK		I	Serial interface (serial data clock)
	3	DI		I	Serial interface (serial data input)
	4	DO		O	Serial interface (serial data output)
	5	GND			GND pin
	6	NC			Not connected
	7	NC			Not connected
	8	VCC		I	Power supply terminal
IC704	1	GND	GND		GND pin
	2	I/O-1	EX-OUT	O	This output terminal have no connection with Band, and reverse when EX-IN input.
	3	I/O-2	EX-RESET	I	Reset EX-OUT
	4	I/O-3	EX-IN	I	Whenever EX-IN input, EX-OUT reverse.
	5	I/O-4	Moni-en	I	Permit to select source, T1, T2, V1 or V2.
	6	I/O-5	Func-en	I	Permit to select a function F1 through F5.
	7	I/O-6	F-Mute	O	This is the Mute output terminal when select Moni or Function.
	8	I/O-7	P-SW	I	Remote control receiver ON/OFF and P-Cont control input.
	9	I/O-8	P-CONT	O	Power supply control
	10	I/O-9	VR-UP	O	VR-UP output
	11	I/O-10	VR-DN	O	VR-DOWN output
	12	SO	SO	O	Serial data output
	13	SI	SI	I	Serial data input
	14	CK	CK	I	Serial clock signal input
	15	STB	STB	I	Strobe signal input
	16	V <sub>DD</sub>	V <sub>DD</sub>	I	5V ± 10% power supply terminal
IC706 IC707	1	AD1		I	Chip select • address set input
	2	CG/DO		I/O	Ramp test input and data output terminal
	3	LS		I	Serial data input terminal (strobe signal)
	4	$\overline{\text{CL}}$		I	Clear signal input terminal (driver off)
	5	VDD		I	Power supply terminal
	6	HVO-20		O	Driver output terminal
	7	HVO-19		O	Driver output terminal
	8	HVO-18		O	Driver output terminal

	Terminal number	Port name	Terminal code	I/O	Outline of functions
<b>IC706</b>	9	HVO-17		O	Driver output terminal
	10	HVO-16		O	Driver output terminal
	11	HVO-15		O	Driver output terminal
	12	HVO-14		O	Driver output terminal
	13	HVO-13		O	Driver output terminal
	14	HVO-12		O	Driver output terminal
	15	HVO-11		O	Driver output terminal
	16	HVO-10		O	Driver output terminal
	17	HVO-9		O	Driver output terminal
	18	HVO-8		O	Driver output terminal
<b>IC707</b>	19	HVO-7		O	Driver output terminal
	20	HVO-6		O	Driver output terminal
	21	HVO-5		O	Driver output terminal
	22	HVO-4		O	Driver output terminal
	23	HVO-3		O	Driver output terminal
	24	HVO-2		O	Driver output terminal
	25	HVO-1		O	Driver output terminal
	26	VDR		I	Power supply terminal
	27	GND			GND pin
	28	CLK		I	Serial data input terminal (clock signal)
	29	DIN		I	Serial data input terminal (data)
	30	AD2		I	Chip select • address set input

**SCHEMATIC DIAGRAM  
(FM TUNER)**

**(INFRARED REMOTE CONTROL)**

● For North America area model

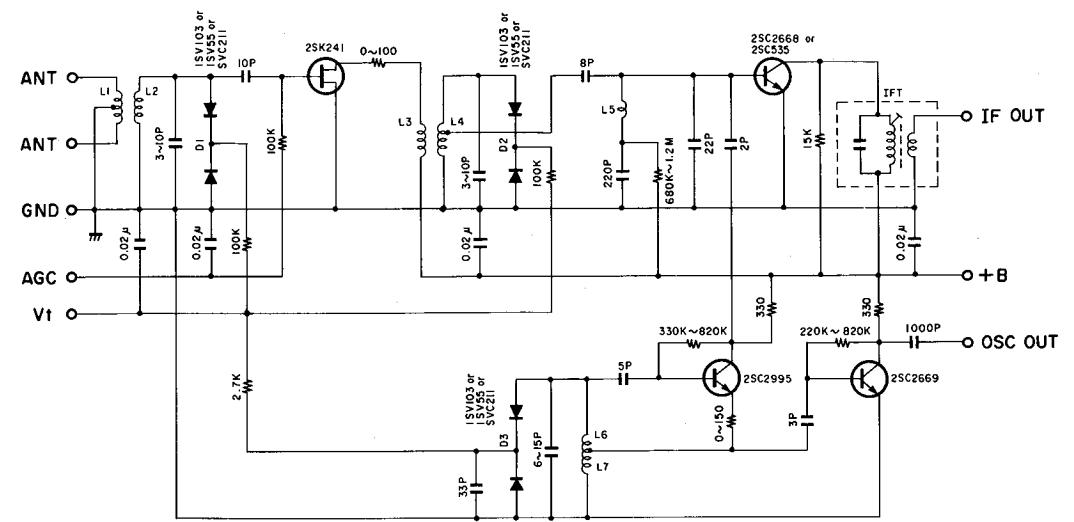

● For International and Australia models

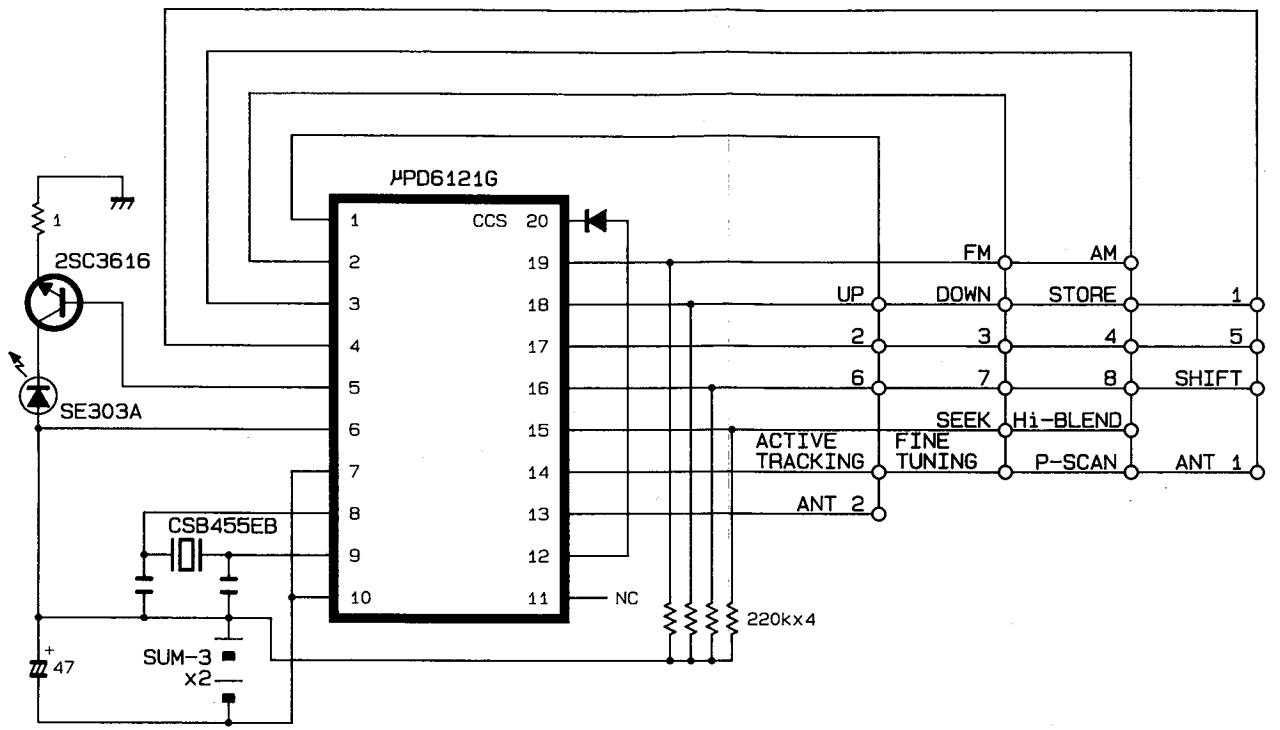
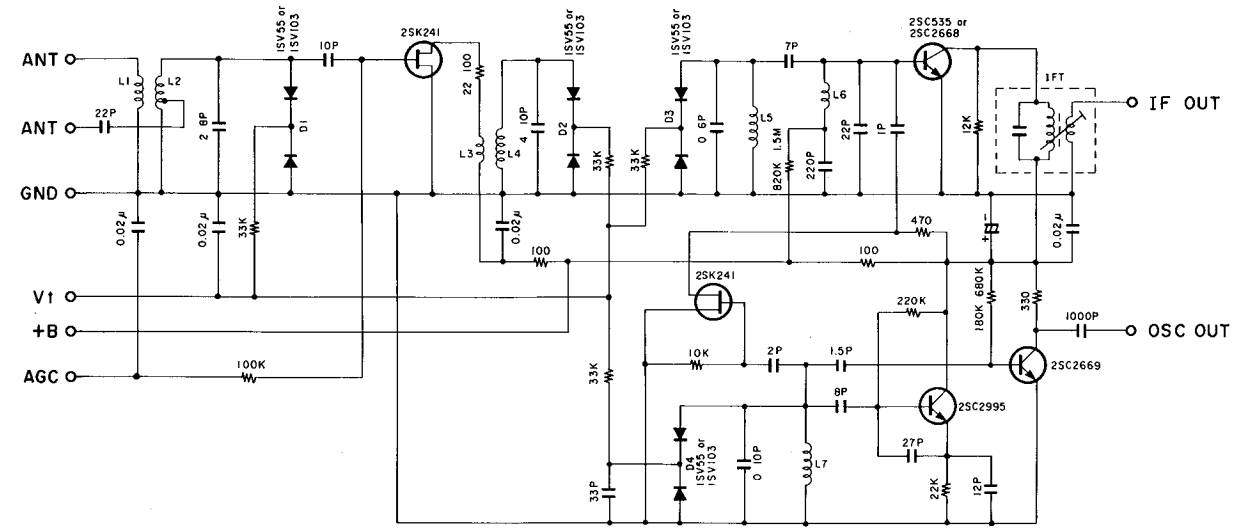

NOTE: Infrared Remote Control parts not available.  
Schematic diagram supplied for reference only.

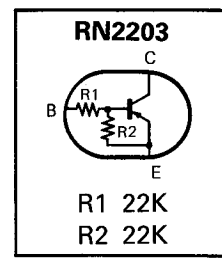
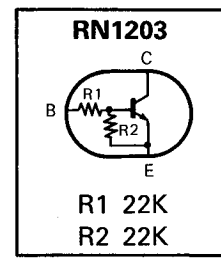

NOTE: Front End parts not available.  
Schematic diagram supplied for reference only.

**SCHEMATIC DIAGRAM  
(FM TUNER)**

● For North America area model

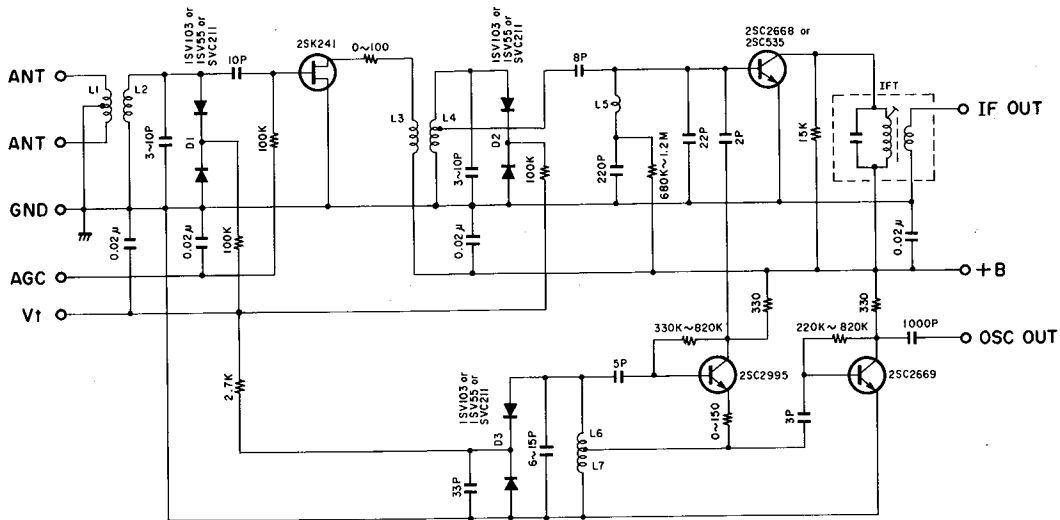

● For International and Australia models

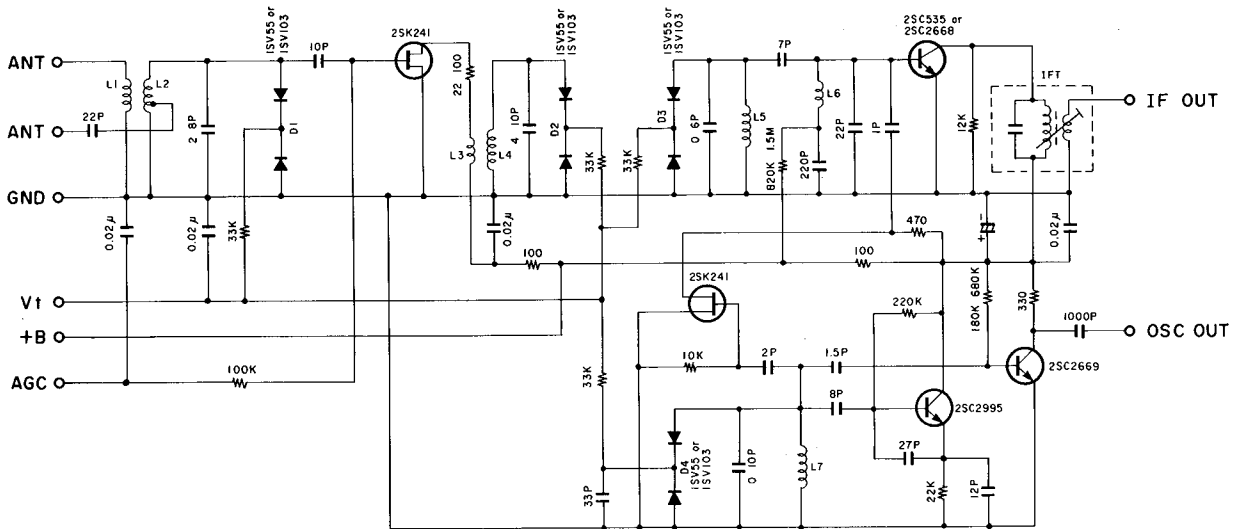

NOTE: Front End parts not available.  
Schematic diagram supplied for reference only.

(INFRARED REMOTE CONTROL)

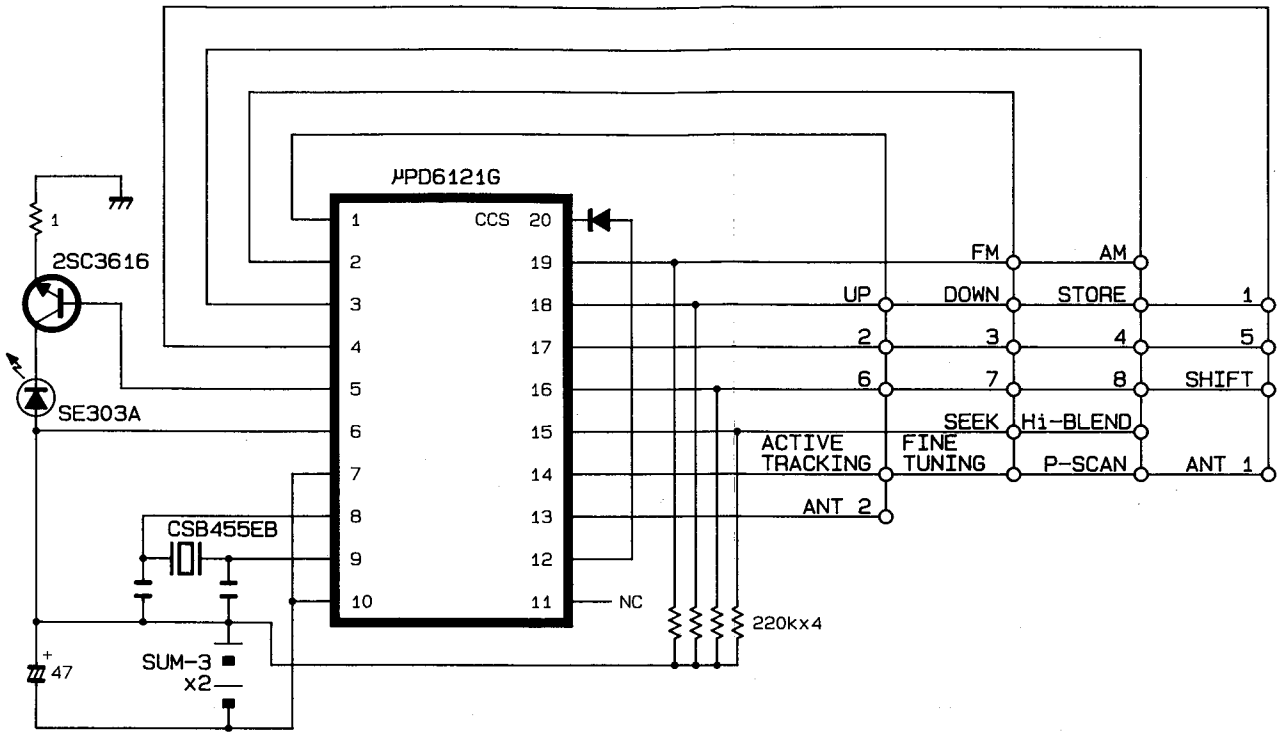

NOTE: Infrared Remote Control parts not available.  
Schematic diagram supplied for reference only.

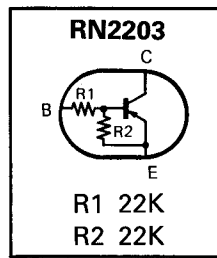
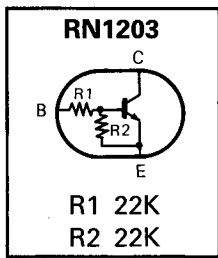

SCHMATIC DIAGRAM

Page 27

Page 27

PCB-2

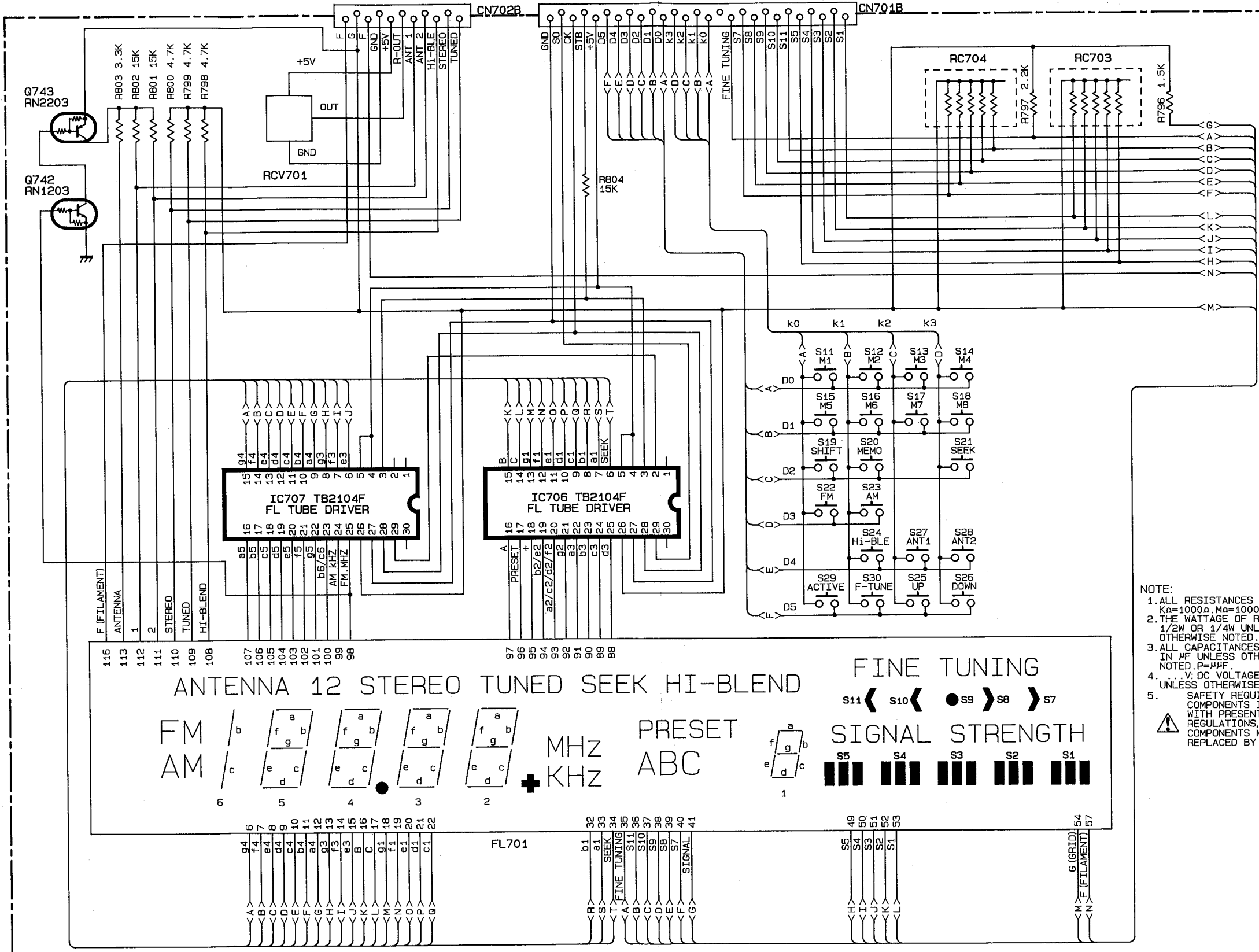

NOTE:  
 1. ALL RESISTANCE VALUES ARE IN Ω.  
 KΩ=1000Ω MΩ=1000KΩ  
 2. THE WATTAGE OF RESISTORS IS 1/2W OR 1/4W UNLESS OTHERWISE NOTED.  
 3. ALL CAPACITANCE VALUES ARE IN μF UNLESS OTHERWISE NOTED. P=μF.  
 4. ... V: DC VOLTAGE AT NO SIGNAL UNLESS OTHERWISE NOTED.  
 5. SAFETY REQUIREMENTS COMPONENTS IN ACCORDANCE WITH PRESENT SAFETY REGULATIONS, THESE COMPONENTS MUST ONLY BE REPLACED BY ORIGINAL PARTS.



SCHEMATIC DIAGRAM

Page 27

1  
2  
3  
4  
5  
6  
7

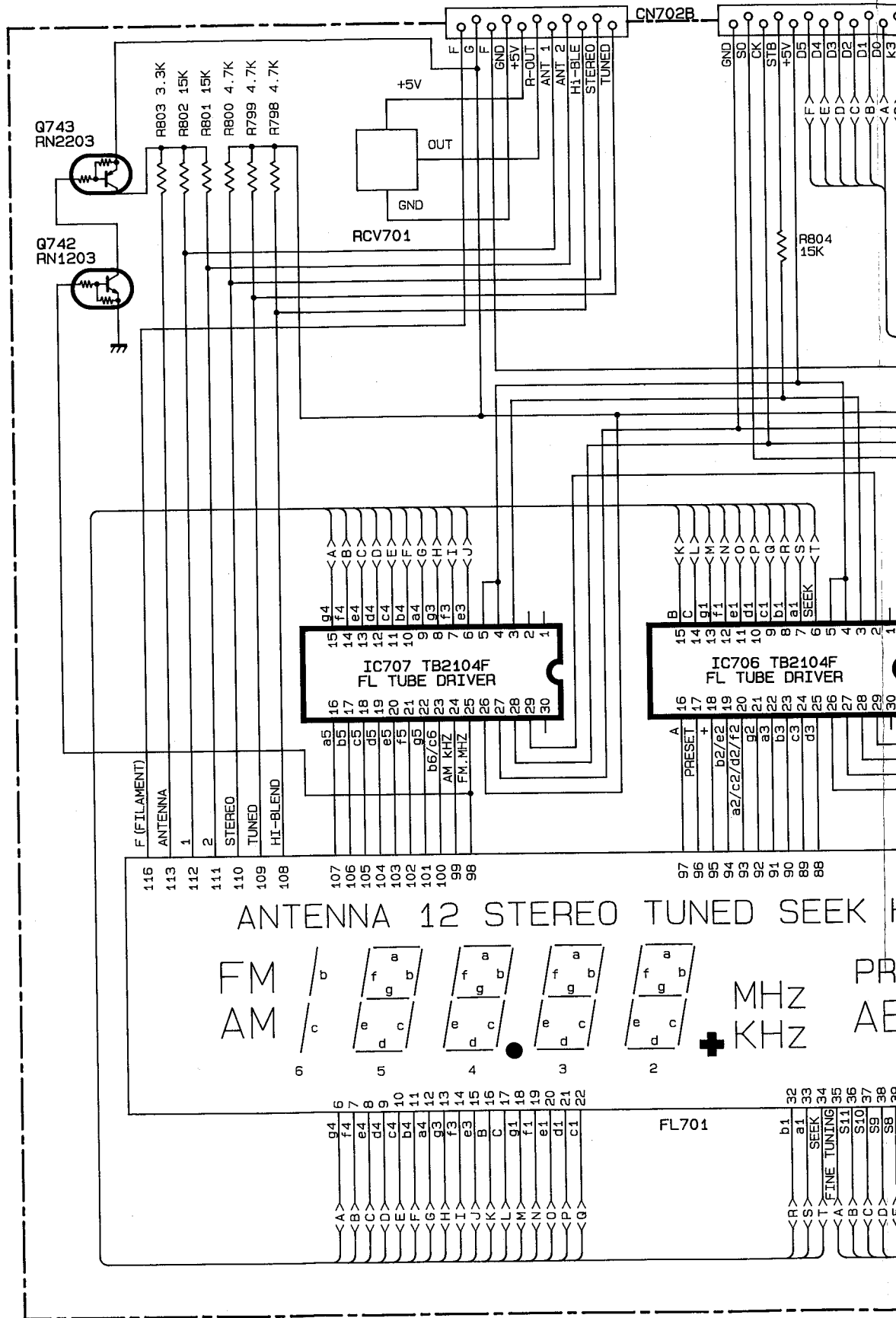



(A)

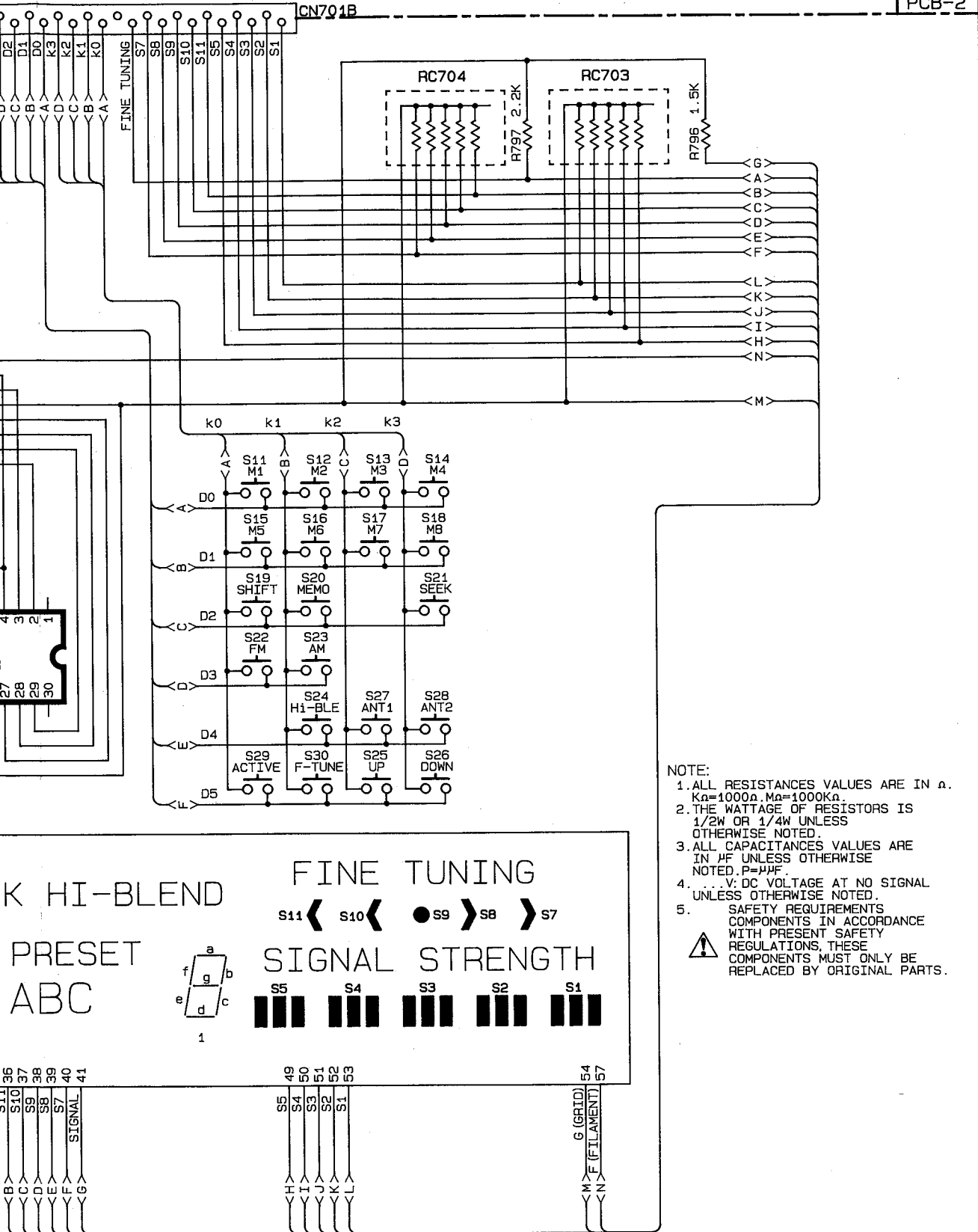

- NOTE:
1. ALL RESISTANCES VALUES ARE IN  $\Omega$ .  
K $\Omega$ =1000 $\Omega$ , M $\Omega$ =1000K $\Omega$ .
  2. THE WATTAGE OF RESISTORS IS 1/2W OR 1/4W UNLESS OTHERWISE NOTED.
  3. ALL CAPACITANCES VALUES ARE IN  $\mu$ F UNLESS OTHERWISE NOTED. P= $\mu$ F.
  4. ... V: DC VOLTAGE AT NO SIGNAL UNLESS OTHERWISE NOTED.
  5. SAFETY REQUIREMENTS COMPONENTS IN ACCORDANCE WITH PRESENT SAFETY REGULATIONS, THESE COMPONENTS MUST ONLY BE REPLACED BY ORIGINAL PARTS.





# SCHEMATIC DIAGRAM

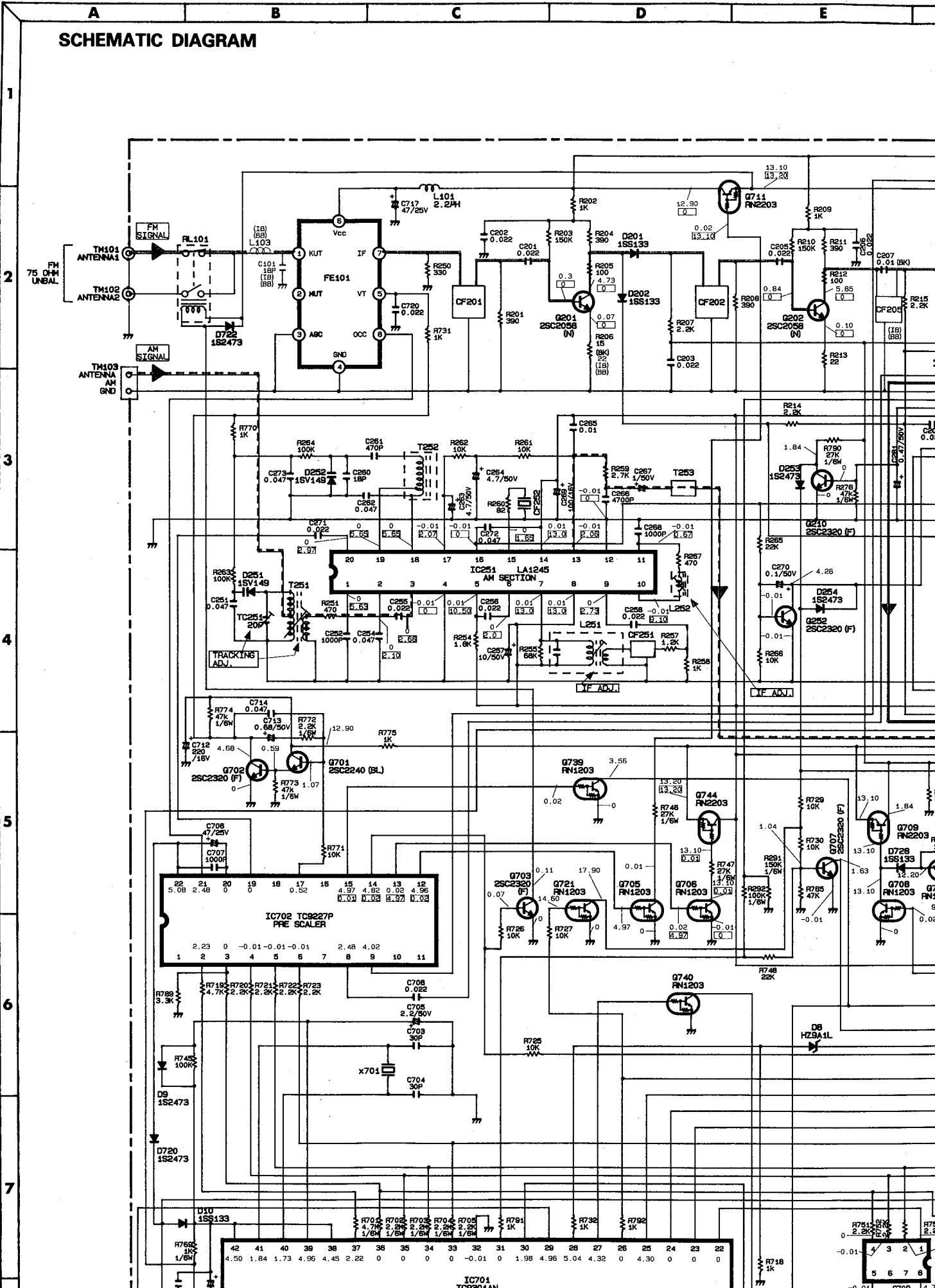

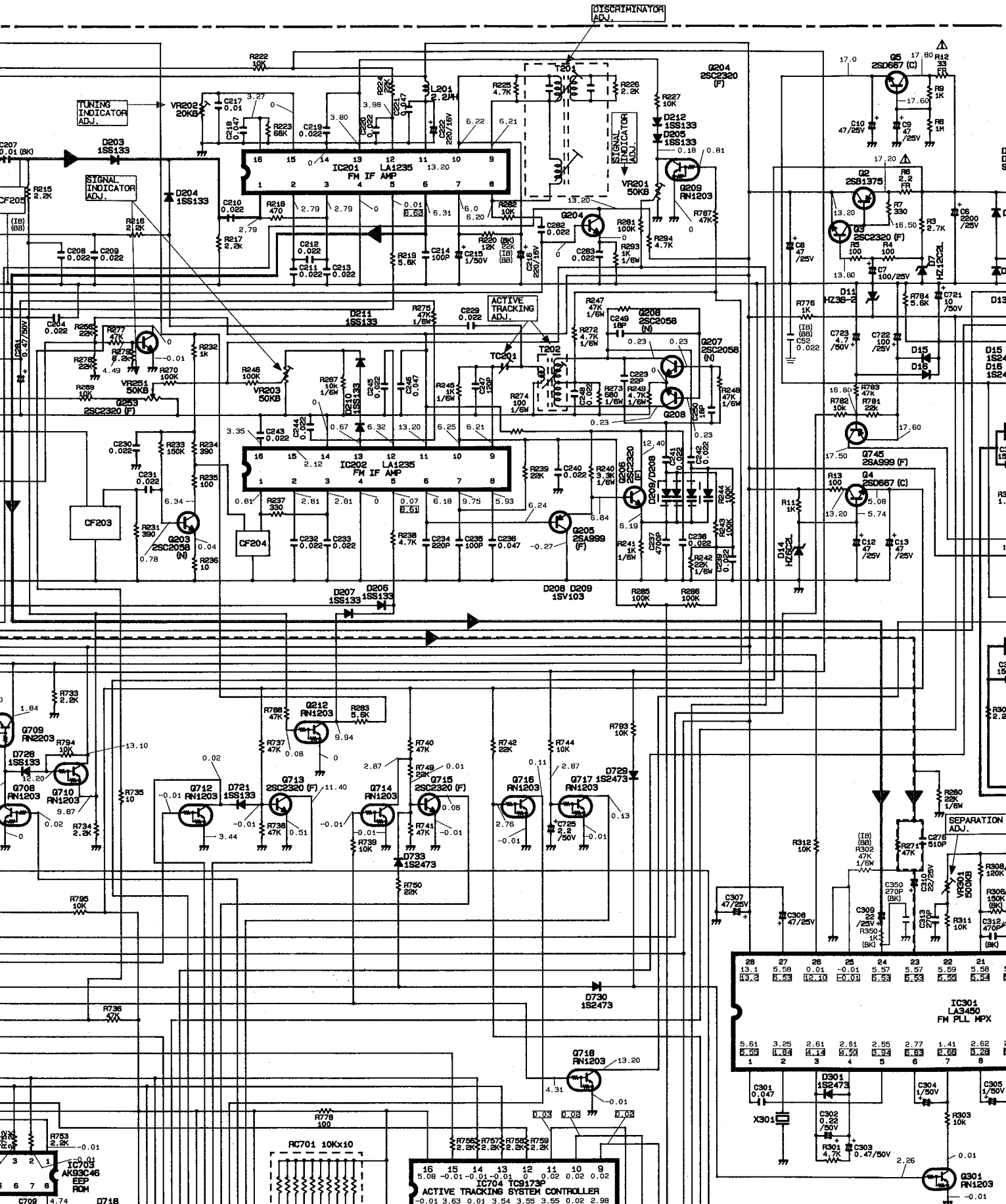

28	27	26	25	24	23	22	21
13.1	5.58	0.01	-0.01	5.57	5.57	5.59	5.58
13.2	5.53	0.00	0.00	5.53	5.53	5.55	5.54

ACTIVE TRACKING SYSTEM CONTROLLER  
 16 15 14 13 12 11 10 9  
 5.08 -0.01 -0.01 -0.01 5.57 5.55 0.02 2.99  
 -0.01 3.63 0.01 3.54 3.55 0.02 2.99

J K L M N

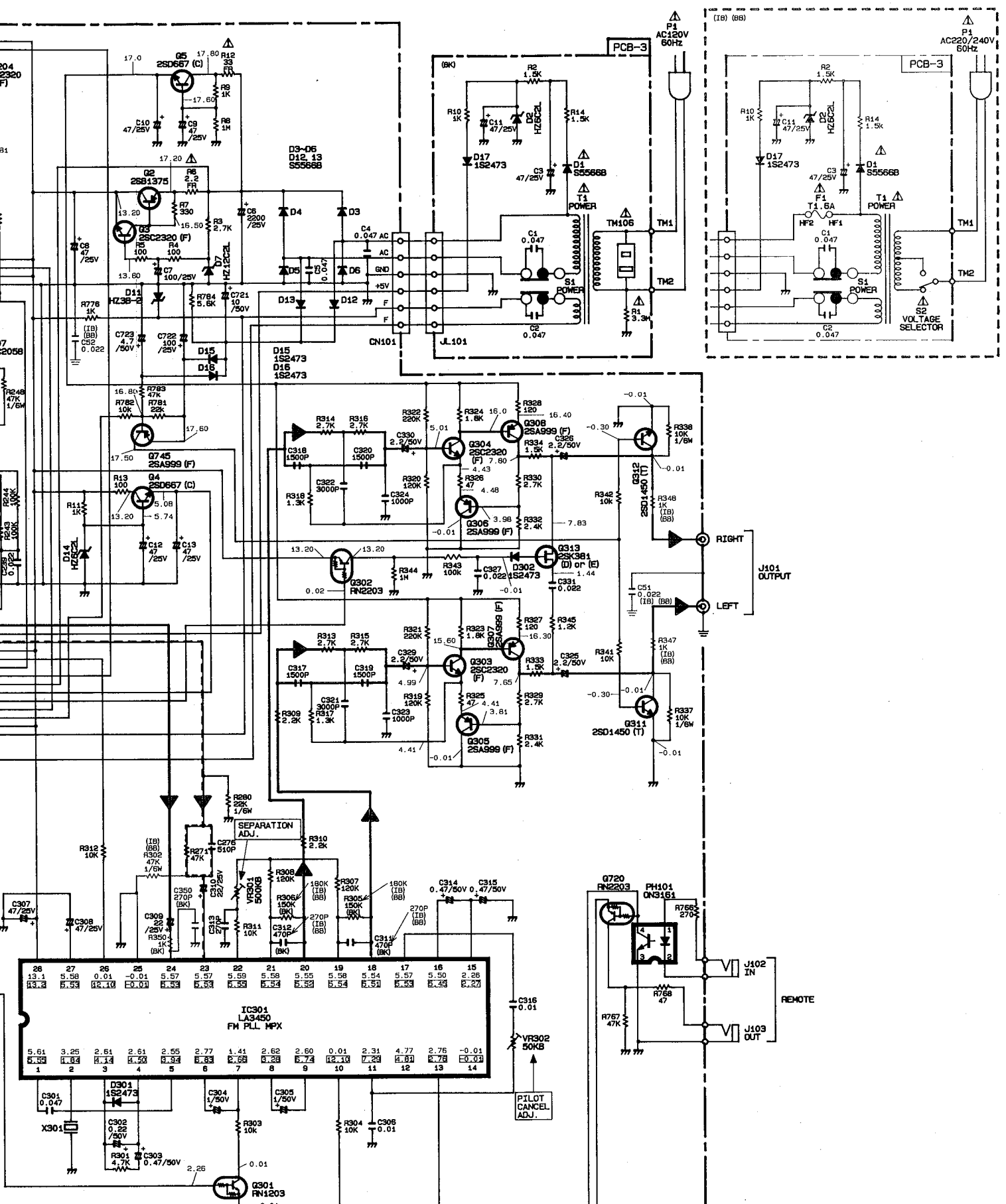

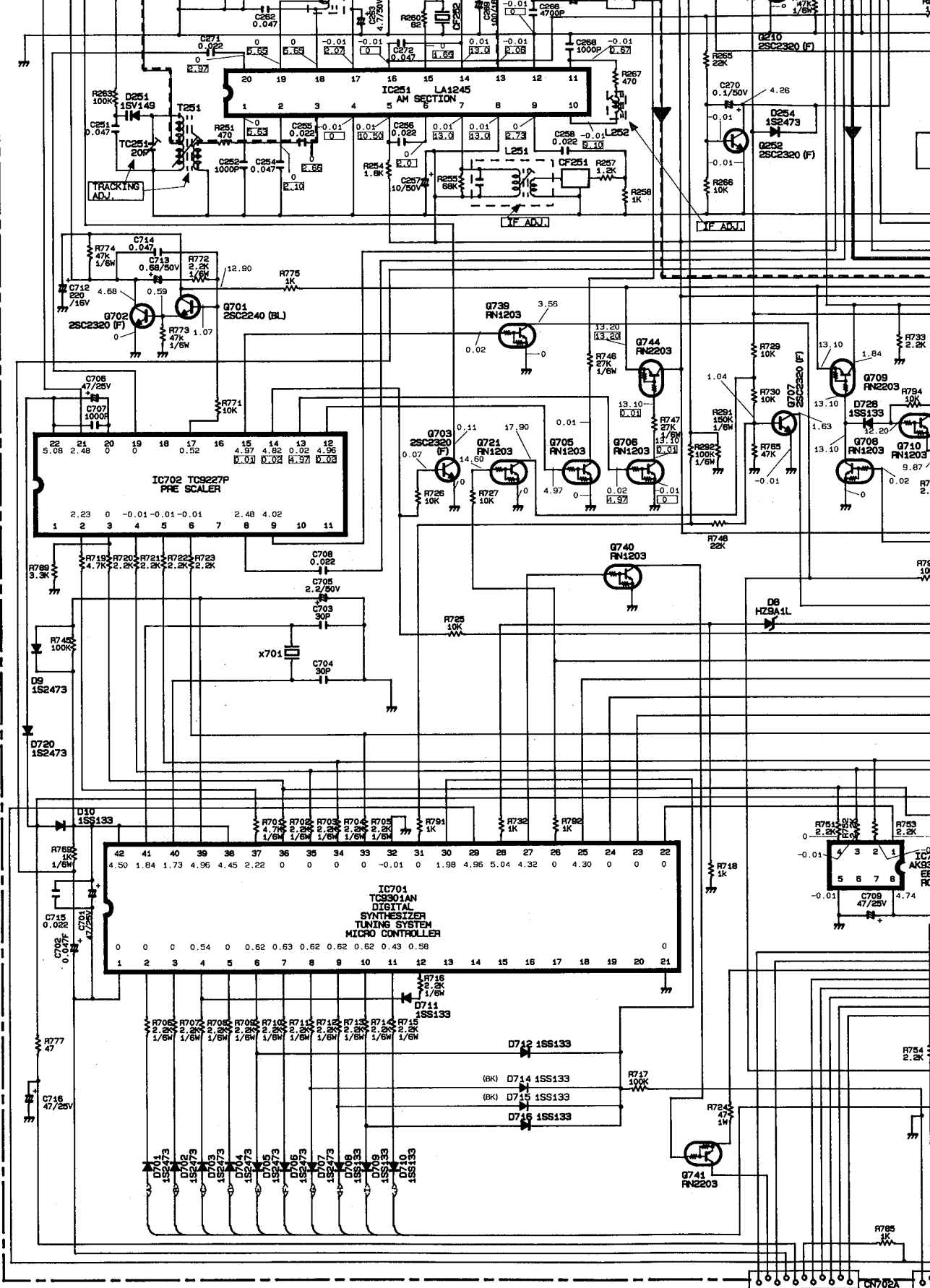

NOTE:  
 1. ALL RESISTANCES VALUES ARE IN  $\Omega$ , K $\Omega$ =1000 $\Omega$ , M $\Omega$ =1000K $\Omega$ .  
 2. THE MATH OF RESISTORS IS 1/2W OR 1/4W UNLESS OTHERWISE NOTED.  
 3. ALL CAPACITANCES VALUES ARE IN pF UNLESS OTHERWISE NOTED. P=PPF.  
 4. ...V: DC VOLTAGE AT NO SIGNAL UNLESS OTHERWISE NOTED.  
 5. SAFETY REQUIREMENTS COMPONENTS IN ACCORDANCE WITH PRESENT SAFETY REGULATIONS.  
 THESE COMPONENTS MUST ONLY BE REPLACED BY ORIGINAL PARTS.

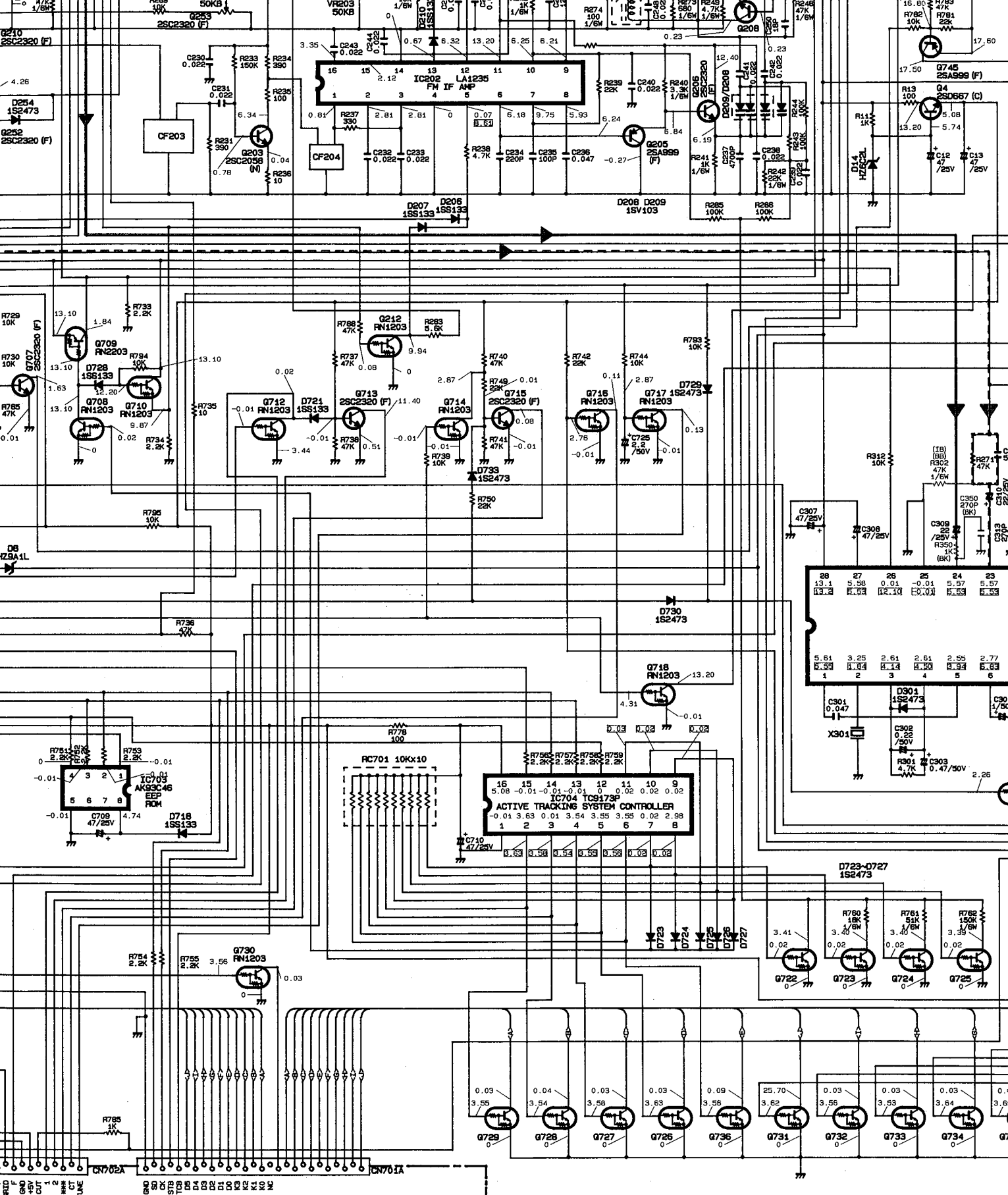

16	15	14	13	12	11	10	9
5.08	-0.01	-0.01	-0.01	0.01	0.02	0.02	0.02
-0.04	3.63	0.01	3.54	3.55	3.55	0.02	2.98
1	2	3	4	5	6	7	8

28	27	26	25	24	23
13.1	5.58	0.01	-0.01	5.97	5.57
5.53	4.34	4.13	4.50	4.34	6.03
1	2	3	4	5	6



