

# STANDARD COLOR CODE — RESISTORS AND CAPACITORS

| AXIAL LEAD RESISTOR                    | INSULATED<br>UNINSULATED<br>Color   | FIRST RING<br>BODY COLOR<br>First Figure       | SECOND RING<br>END COLOR<br>Second Figure      | THIRD RING<br>DOT COLOR<br>Multiplier   | DISC CERAMIC RMA CODE |
|--|---|--|--|---|-----------------------|
|  | BLACK<br>BROWN<br>RED<br>ORANGE<br>YELLOW<br>GREEN<br>BLUE<br>VIOLET<br>GRAY<br>WHITE | 0<br>1<br>2<br>3<br>4<br>5<br>6<br>7<br>8<br>9 | 0<br>1<br>2<br>3<br>4<br>5<br>6<br>7<br>8<br>9 | None<br>0<br>00<br>.000<br>0.000<br>00,000<br>000,000<br>0.000,000<br>00,000,000<br>000,000,000 |                       |
| <b>RADIAL LEAD DOT RESISTOR</b><br>    | <b>5-DOT RADIAL LEAD CERAMIC CAPACITOR</b><br>  |  |  | <b>EXTENDED RANGE TC CERAMIC HICAP</b><br>  |                       |
| <b>RADIAL LEAD (BAND) RESISTOR</b><br> | <b>BY-PASS COUPLING CERAMIC CAPACITOR</b><br>   |  |  | <b>AXIAL LEAD CERAMIC CAPACITOR</b><br>   |                       |

The standard color code provides all necessary information required to properly identify color coded resistors and capacitors. Refer to the color code for numerical values and the zeroes or multipliers assigned to the colors used. A fourth color band on resistors determines tolerance rating as follows: Gold = 5%, silver = 10%. Absence of the fourth band indicates a 20% tolerance rating.

The physical size of carbon resistors is determined by their wattage rating. Carbon resistors most commonly used in Heathkits are 1/2 watt. Higher wattage rated resistors when specified are progressively larger in physical size. Small wire wound resistors 1/2 watt, 1 or 2 watt may be color coded but the first band will be double width.

## MOLDED MICA TYPE CAPACITORS

|                                      |  |   |
|--------------------------------------|--|---|
| <b>CURRENT STANDARD CODE</b><br>     | <b>RMA 3-DOT (OBSOLETE)</b><br>RATED 500 W.V.D.C. ± 20% TOL.<br> | <b>BUTTON SILVER MICA CAPACITOR</b><br> |
| <b>RMA (5-DOT OBSOLETE CODE)</b><br> | <b>RMA 6-DOT (OBSOLETE)</b><br>                                  | <b>RMA 4-DOT (OBSOLETE)</b><br>         |

## MOLDED PAPER TYPE CAPACITORS

|  |   |                                |
|--|---|--------------------------------|
| <b>TUBULAR CAPACITOR</b><br><p>A 2 digit voltage rating indicates more than 900 V. Add 2 zeros to end of 2 digit number.</p> | <b>MOLDED FLAT CAPACITOR</b><br>Commercial Code<br> | <b>JAN. CODE CAPACITOR</b><br> |
|--|---|--------------------------------|

The tolerance rating of capacitors is determined by the color code. For example: red = 2%, green = 5%, etc. The voltage rating of capacitors is obtained by multiplying the color value by 100. For example: orange = 3 × 100 or 300 volts. Blue = 6 × 100 or 600 volts.

In the design of Heathkits, the temperature coefficient of ceramic or mica capacitors is not generally a critical factor and therefore Heathkit manuals avoid reference to temperature coefficient specifications.

Assembly  
and  
Operation  
of the

**HEATHKIT** by **DAYSTROM**

**STEREO  
AMPLIFIER  
MODEL AA-100**



HEATH COMPANY,  
BENTON HARBOR,  
MICHIGAN

a subsidiary of  
**DAYSTROM, INCORPORATED**

**TABLE OF CONTENTS**

|   |     |
|---|-----|
| Specifications. . . . .                       | 2   |
| Circuit Description. . . . .                  | 7   |
| Construction Notes. . . . .                   | 11  |
| Parts List. . . . .                           | 12  |
| Proper Soldering Techniques. . . . .          | 15  |
| Chassis Wiring And Soldering. . . . .         | 15  |
| Circuit Board Wiring And Soldering. . . . .   | 17  |
| Step-By-Step Procedure. . . . .               | 18  |
| Step-By-Step Assembly. . . . .                | 19  |
| Chassis Wiring. . . . .                       | 23  |
| Installation of Input Level Controls. . . . . | 32  |
| Initial Hum Balance Adjustment. . . . .       | 38  |
| Installation. . . . .                         | 38  |
| Operation. . . . .                            | 41  |
| In Case of Difficulty. . . . .                | 43  |
| Service Information. . . . .                  | 44  |
| Service. . . . .                              | 44  |
| Replacements. . . . .                         | 46  |
| Shipping Instructions. . . . .                | 46  |
| Bibliography. . . . .                         | 47  |
| Warranty. . . . .                             | 47  |
| Schematic. . . . .                            | 47* |

\*Fold-out from Page.

All prices are subject to change without notice. The Heath Company reserves the right to discontinue instruments and to change specifications at any time without incurring any obligation to incorporate new features in instruments previously sold.



**SPECIFICATIONS**

|   |  |
|---|--|
| Power Output: . . . . .   | 25 watts Stereophonic (each channel).<br>50 watts Monophonic.  |
| Music Power Rating: . . . . .                                     | 30 watts stereophonic (.7% total harmonic distortion at 1 kc.)<br>60 watts monophonic (.7% total harmonic distortion at 1 kc.) |
| Input sensitivity - volts rms<br>for 25 watts output per channel: |  |
| MONOphonic PHONO* (on Left<br>Channel only): . . . . .            | 1.5 mv.  |
| STEREOphonic PHONO*: . . . . .                                    | 1.5 mv.  |
| TAPE HEAD: . . . . .  | 1.0 mv.  |
| TUNER: . . . . .  | 0.2 V.   |
| AUXiliary 1: . . . . .  | 0.2 V.   |
| AUXiliary 2: . . . . .  | 0.2 V.   |
| *For Magnetic Cartridges  |  |
| Input Impedances:   |  |
| PHONO: . . . . .  | 47 KΩ supplied; may be changed if cartridge so requires.   |
| TAPE HEAD: . . . . .  | 470 KΩ.  |
| TUNER and AUXiliary: . . . . .                                    | 250 KΩ each.   |

- Output Impedances: . . . . . 4, 8 and 16  $\Omega$  each channel.
- Tape Recorder Output: . . . . . Approximately 0.5 volt maximum at source resistance of approximately 600  $\Omega$  from cathode follower. Minimum recommended load resistance: 150 K $\Omega$ .
- Frequency Response: . . . . .  $\pm 1$  db 30-15,000 cps at 25 watts, from auxiliary inputs, See Graph A.

GRAPH A

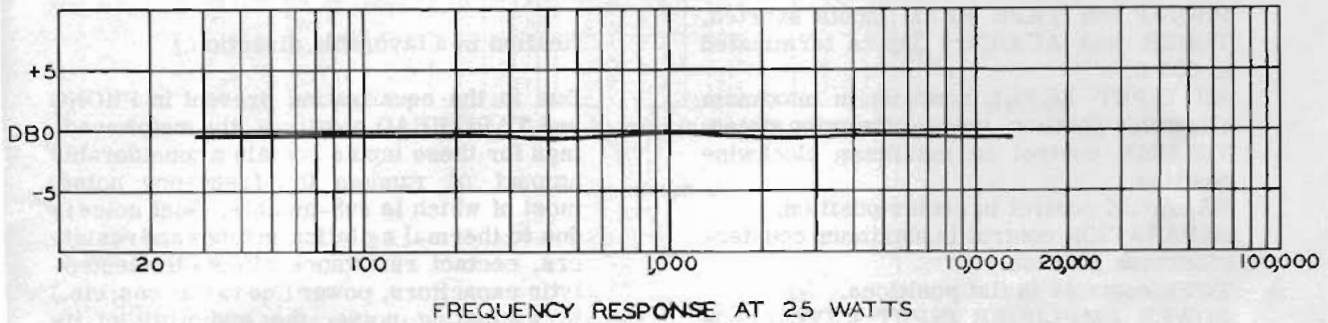

- Channel Separation: . . . . . 42 db minimum at 1000 cps.
- Damping Factor: . . . . . 15.
- Harmonic Distortion: . . . . . Less than 0.5% at 25 watts, 1000 cps. Less than 2% at 25 watts, 30-15,000 cps.
- Intermodulation Distortion: . . . . . Less than 1% at 25 watts, 60 and 6000 cps mixed 4:1. See Graph B.

GRAPH B

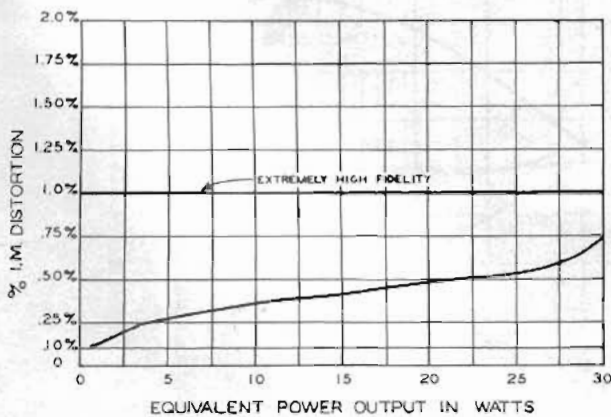

NOTE: Harmonic and intermodulation distortion specifications are typical for either channel operating at the stated power output. Measurements were made under the following conditions:

Signal generator fed to both channels simultaneously, using AUX 1 inputs in parallel.

Left Channel and Right Channel amplifiers both operating at equal power output, into individual resistive loads.

Line voltage constant, 117 volts.



**Hum and Noise:**

|  |         |
|--|---------|
| PHONO (with PHONO LEVEL control adjusted for sensitivity of 6.0 mv at 1000 cps): . . . . . | 55 db*. |
| TAPE HEAD: . . . . .   | 35 db*. |
| TUNER and AUXiliary Inputs: . . . . .  | 70 db*. |

\*The number of db below 25 watts output in either channel, measured under the following conditions:

PHONO and TAPE HEAD inputs shorted, TUNER and AUXiliary inputs terminated in 600  $\Omega$ .

All INPUT LEVEL controls in maximum clockwise position, unless otherwise stated, VOLUME control in maximum clockwise position,

BALANCE control in center position,

SEPARATION control in maximum counter-clockwise position.

TONE controls in flat positions.

POWER AMPLIFIER INPUT LEVEL controls in maximum clockwise position.

LEFT PHASE switch in NORM position.

Both SPEAKER OUTPUTS loaded with 16  $\Omega$  resistive load.

The hum and noise figures stated above are unweighted (uncorrected for hearing characteristics) and represent rms values as read on an AC vacuum tube voltmeter. (It is to be noted that the application of a "weighting characteristic" would alter the speci-

fication in a favorable direction.)

Due to the equalization present in PHONO and TAPE HEAD positions, the meter readings for these inputs contain a considerable amount of random low-frequency noise, most of which is sub-audible. (Such noise is due to thermal agitation in tubes and resistors, contact resistance effects in electrolytic capacitors, power line variations, etc.) In evaluating noise, the audibility of its various components must be considered. The extreme input sensitivity (1 millivolt) of the AA-100 TAPE HEAD input must also be borne in mind.

The actual 60 cycle hum (and harmonics) included in the readings is very small, compared to the mostly sub-audible noise components referred to above. As a matter of fact, the AA-100 is almost completely free from hum, for practical purposes.

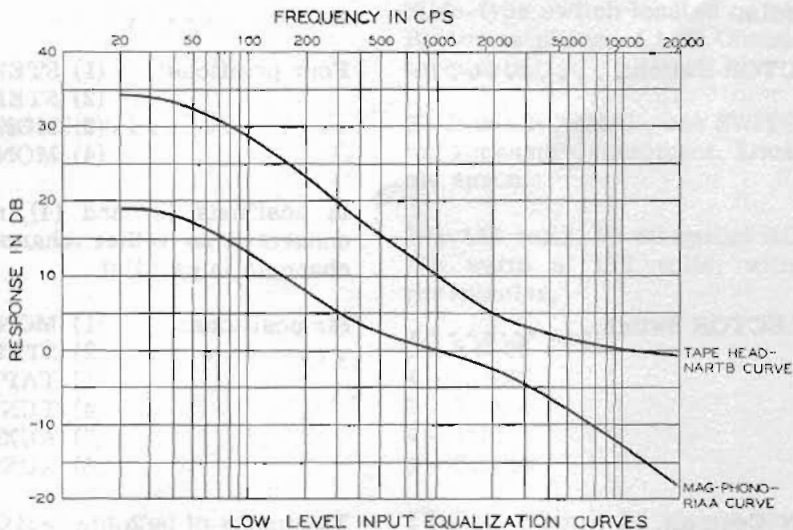

Graph C

Equalization:

PHONO: . . . . .

RIAA curve.

TAPE HEAD: . . . . .

NARTB tape playback curve. See Graph C.

Tone Controls: . . . . .

Separate BASS and TREBLE controls in each channel. BASS control provides approximately 15 db boost and 17 db cut at 30 cps, TREBLE control provides approximately 12 db boost and 20 db cut at 15,000 cps. See Graph D for curves.

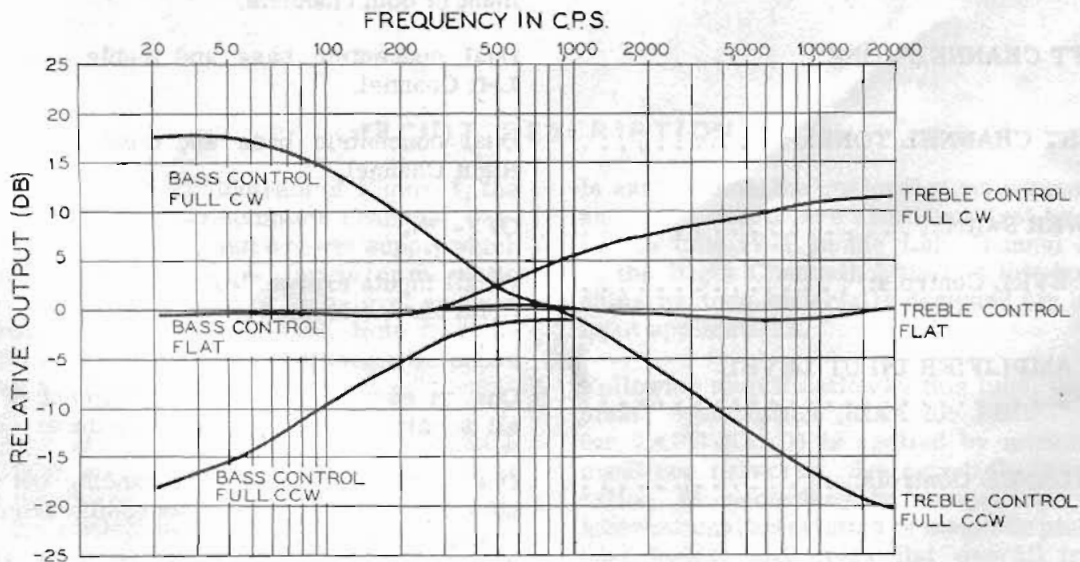

GRAPH D-TONE CONTROL CURVES

## Front Panel Controls:

|   |                 |   |
|---|-----------------|---|
| MODE SELECTOR Switch: . . . . .                 | Four positions: | (1) STEREO NORMAL<br>(2) STEREO REVERSE<br>(3) MONOPHONIC LEFT<br>(4) MONOPHONIC RIGHT  |
|   |                 | In positions (3) and (4), monophonic sources connected to either channel are fed to both channels in parallel.  |
| SOURCE SELECTOR Switch: . . . . .               | Six positions:  | (1) MONOPHonic PHONO<br>(2) STEREO PHONO<br>(3) TAPE HEAD<br>(4) TUNER<br>(5) AUXiliary 1<br>(6) AUXiliary 2  |
| SEPARATION Control: . . . . .                   |                 | The inputs of both the Left Channel and the Right Channel are <u>simultaneously</u> switched to any of the above stereo pairs of inputs. <u>Exception:</u> Position (1) is a monophonic input to the Left Channel only. |
| BALANCE Control: . . . . .                      |                 | Raises volume level of either channel while lowering it in the other. Range 8 db per channel for a total balance range of 16 db.  |
|   |                 | Mixes Left and Right Channels over a range of 0 to 100%.  |
|   |                 | (BALANCE and SEPARATION controls are concentric.)   |
| VOLUME Control: . . . . .                       |                 | Dual tandem type for simultaneous level adjustment of both channels.  |
| LEFT CHANNEL TONE: . . . . .                    |                 | Dual concentric bass and treble controls for Left Channel.  |
| RIGHT CHANNEL TONE: . . . . .                   |                 | Dual concentric bass and treble controls for Right Channel.   |
| POWER Switch: . . . . .                         |                 | OFF-ON.   |
| INPUT LEVEL Controls: . . . . .                 |                 | On all inputs except TAPE HEAD. Controls are located under chassis.   |
| POWER AMPLIFIER INPUT LEVEL Controls: . . . . . |                 | One in each channel, for adjustment of over-all sensitivity. Accessible from under chassis.   |
| HUM BALANCE Controls: . . . . .                 |                 | One in each channel, for balancing out 60 cps hum from heater circuits. Accessible from under chassis.  |

|                                       |  |
|---------------------------------------|--|
| PHASE Switch: . . . . .               | Slide-type switch located on rear chassis apron. Reverses phase of Left Channel at loudspeaker terminals.                    |
| 117 Volt Power Receptacles: . . . . . | Two: one NORMAL, one SWITCHED, for powering accessory equipment. Located on rear chassis apron.                              |
| Power Requirements: . . . . .         | 105-125 volts, 50-60 cycles AC.<br>150 watts at 117 volts, with no load on AC receptacles.                                   |
| Tube Complement: . . . . .            | 2 - EF-86<br>4 - 12AX7<br>2 - 7199<br>4 - 7591<br>1 - GZ-34  |
| Dimensions: . . . . .                 | 15-1/4" wide x 5" high x 13-1/2" deep (maximum). NOTE: Feet are included in height dimension.                                |
| Mounting Position: . . . . .          | Horizontal. A 4-3/8" x 14-7/8" opening is required for panel mounting. Vertical mounting (panel horizontal) not recommended. |
| Net Weight: . . . . .                 | 28-3/4 lbs.  |
| Shipping Weight: . . . . .            | 34-1/2 lbs.  |

The foregoing specifications are representative of the performance of the average production unit. Minor variations from the specifications are to be expected. However, such variations are held to a minimum in the Model AA-100,

through the use of printed circuit boards and high quality components. Due to these factors, plus conservative design, these normal variations may be disregarded from a performance standpoint.

## CIRCUIT DESCRIPTION

As shown in the block diagram of Figure 1, the AA-100 consists of two complete channels, designated Left and Right, and a power supply which is common to both channels. Inputs for magnetic phono, tape head, and three high-level sources are provided for each channel. Note that the Left Channel has an additional magnetic phono input for a monophonic cartridge.

All inputs are applied first to the SOURCE SELECTOR switch, which selects the desired pair of inputs for application to the two channels. (When the switch is in the MONO (monophonic) PHONO position, no input is applied to the Right Channel.)

In each channel the low level signals from PHONO and TAPE HEAD are amplified first by the type EF-86 tube (V-1 in the Left Channel and V-2 in the Right Channel). This is a low-hum, low-noise pentode especially designed for low level input applications.

Following amplification by this tube, the appropriate equalization (RIAA for PHONO, NARTB for TAPE HEAD) is applied by means of R-C equalizer networks. See Graph C. This equalization is necessary to compensate for the inherent characteristics of magnetic pickups and tape heads, and gives flat overall frequency response. In addition, the RIAA equalization pro-



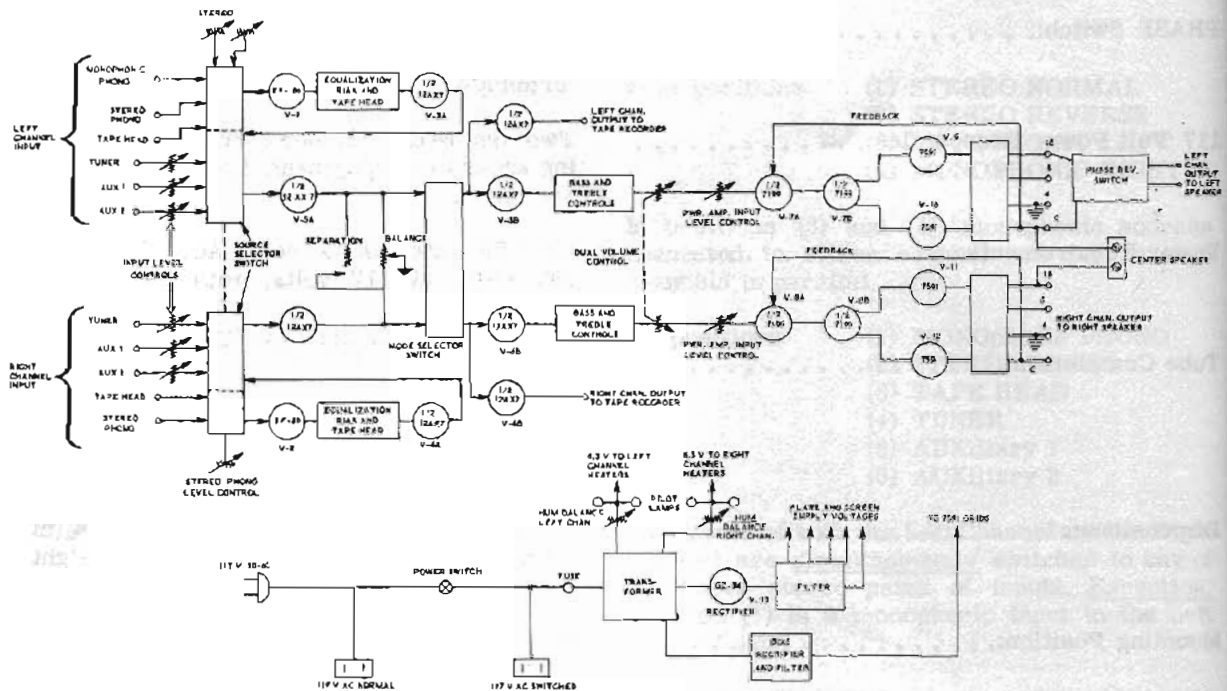

Figure 1

vides a fixed amount of high frequency roll-off (17.2 db at 15,000 cps) which exactly compensates for the high frequency pre-emphasis of the RIAA recording characteristic. This pre-emphasis helps recorded high frequency sound to override surface noise (scratch). The signal, now equalized, is further amplified by one triode section of a type 12AX7 dual triode (V-3A in the Left Channel, and V-4A in the Right Channel). At this point the signal from PHONO, in each channel, is applied to the PHONO LEVEL control (necessary for presetting volume level for a given magnetic cartridge). The Left Channel has both STEREO and MONOPHONIC phono level controls; the appropriate level control is switched into the circuit by the SOURCE SELECTOR switch. There is no level control for TAPE HEAD input of either channel because the signal voltage developed by a tape head will generally be lowest of all signal sources. Thus in making the initial level control adjustments after installing your AA-100, it is only necessary to adjust level controls for the remaining signal sources, until their individual levels equal that obtained from the tape head.

The three high level inputs for each channel are designated TUNER, AUX 1, and AUX 2, each of these having a level control.

Following the SOURCE SELECTOR switch the signal in each channel, regardless of source, is applied to one section of a type 12AX7 dual triode (V-5A in the Left Channel, and V-6A in the Right Channel). From this stage, in each channel, the signal is fed to the MODE SELECTOR switch. However, let us first consider the BALANCE and SEPARATION controls which are connected between the Left and Right Channels at this point in the circuit. The BALANCE control, R-38, is a potentiometer so connected that it forms a part of a voltage divider in both channels. (Refer to the schematic diagram for the circuit details.) In the Left Channel, this voltage divider consists of R-42, R-39, and half of R-38, when this control is in its center position. In the Right Channel, the divider consists of R-34, R-36, and the other half of R-38, since the arm of R-38 is grounded. Therefore, when the control is in its center position, the voltage division produced in each channel by the control and the associated resistors is equal, and the gain of both channels is also equal. If the control is now turned either side of center, the gain of one channel will increase while the gain of the other channel will decrease. Physically, the connections are arranged so that turning the control clockwise from center increases the volume level of the Left Channel, while de-

creasing that of the Right Channel. Of course turning the control counterclockwise from center produces the opposite effect.

The SEPARATION control, R-37, provides control over channel separation, if desired. By means of this control, any degree of mixing (i.e., reduction of channel separation) may be obtained between the two channels. A moderate degree of mixing definitely reduces the "hole-in-the-middle" effect found in some stereo program material.

When this control is turned to its extreme counterclockwise position (marked NORMAL on the panel) it is open-circuited, and there is no mixing effect whatever. As it is turned clockwise, the degree of mixing gradually increases until the two channels are completely mixed, in the extreme clockwise position.

Signals in both channels are next applied to the MODE SELECTOR switch. Figures 2A through 2D illustrate the functions of this switch in each

of its four positions.

**STEREO NORMAL** position: See Figure 2A. Signals from the Left Channel and the Right Channel inputs are fed straight through to the Left Channel output and the Right Channel output, respectively.

**STEREO REVERSE** position: See Figure 2B. In this position signals from the Left Channel inputs are fed to the Right Channel output, and signals from the Right Channel inputs are fed to the Left Channel output.

**MONO LEFT** position: See Figure 2C. In this position any input to the Left Channel may be fed simultaneously to both the Left and Right Channel outputs.

**MONO RIGHT** position: See Figure 2D. In this position any input to the Right Channel may be fed simultaneously to both the Right and Left Channel outputs.

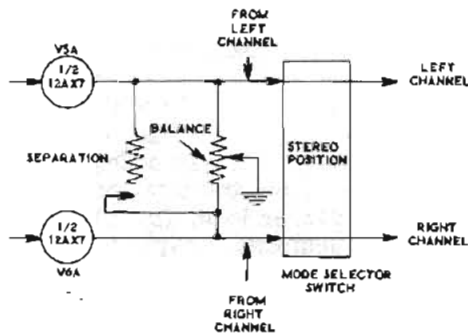

Figure 2A

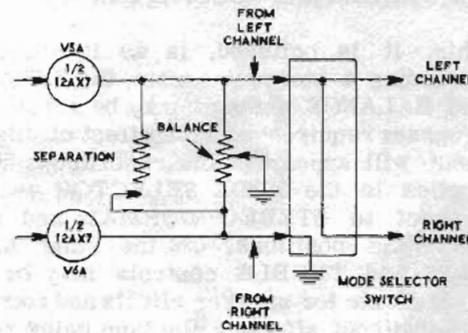

Figure 2C

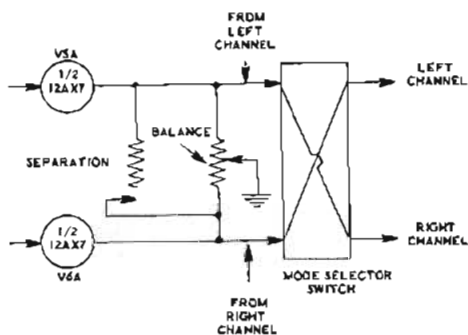

Figure 2B

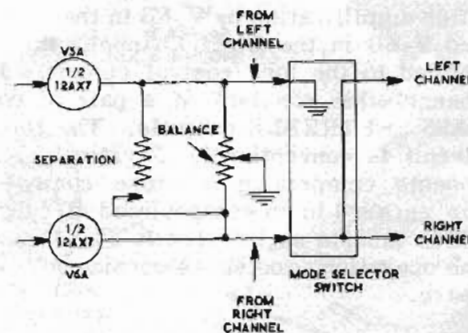

Figure 2D

The signal from the MODE SELECTOR switch feeds the remaining triode section of the 12AX7 in each channel (V-5B and V-6B). It also feeds cathode followers V-3B in the Left Channel and V-4B in the Right Channel, from which connections may be made to feed an external stereo tape recorder. Because of the low output impedance of a cathode follower, the cable(s) feeding the recorder may be any practical length without encountering high frequency loss. Also, the cathode followers give perfect circuit isolation so that the external tape recorder feed does not affect in any way the normal output of the AA-100.

Also, with respect to the tape recorder outputs it should be noted that their take-off points (in each channel) are after the BALANCE and SEPARATION controls and the MODE SELECTOR switch, but before the BASS and TREBLE controls and VOLUME control. Therefore, the tape recorder outputs will be affected by the settings of the SEPARATION and BALANCE controls and the MODE SELECTOR switch; they will not be affected by the settings of the BASS and TREBLE and VOLUME controls.

This, it is believed, is as it should be; in recording a stereo program, the SEPARATION and BALANCE controls may be adjusted as the program requires, and the effect of this adjustment will appear in the recording. The same applies to the MODE SELECTOR switch with respect to STEREO NORMAL and STEREO REVERSE positions. On the other hand, the BASS and TREBLE controls may be used to compensate for speaker effects and room acoustics, without affecting the tape being recorded. Similarly, the VOLUME control may be adjusted for any desired listening volume without affecting the recording level.

After amplification by V-5B in the Left Channel and V-6B in the Right Channel, the signal is applied to the tone control circuit. For each channel this consists of a pair of concentric BASS and TREBLE controls. The tone control circuit is conventional. Physically, the components comprising the tone control network are encased in an encapsulated circuit (#84-13) which mounts on the circuit board in virtually one operation, and saves considerable time and space.

From the tone controls, the signal in each channel is applied to its section of the dual VOLUME control, R-68 and R-60. This is the

main or "master" VOLUME control, and is operated from the front panel. It is a ganged potentiometer, thus affording single-knob volume control for both channels. In the manufacture of this control, its dual elements have been matched for close tracking, so the volume change is equal - within 2 db or better - for both channels, over most of the control rotation.

From this control the signal in each channel goes to individual level controls (PWR. AMP. INPUT LEVEL CONTROLS R-70 and R-78). By means of these, the gain of either channel may be permanently reduced to correct for differences in efficiency of the two speakers used.

Signal is then applied to each power amplifier, which consists of a type 7199 pentode-triode tube (V-7 in the Left Channel and V-8 in the Right Channel) and two type 7591 power output tubes, connected in push-pull. The pentode section of the 7199 serves as a voltage amplifier. It is direct-coupled to the triode section which is connected as a phase splitter, delivering push-pull (out-of-phase) signal voltages to the control grids of the 7591 tubes (V-9 and V-10 in the Left Channel; V-11 and V-12 in the Right Channel). Output power developed in the plate circuit of each of these tubes is added in the output transformer, where the total power is coupled to the loudspeaker load. The tubes are operated as straight pentodes, with plate, screen and bias potential chosen for maximum undistorted power output. A fixed bias of -16 volts for the control grids is derived from a separate half-wave selenium rectifier, which obtains its voltage from a tap on the high-voltage secondary winding of the power transformer.

Approximately 18 db of overall negative feedback is applied around each amplifier, from the output transformer secondary back to the cathode of the 7199 pentode section. This feedback loop reduces distortion, flattens frequency response and increases the damping factor of each power amplifier.

A pair of terminals is provided for connection to a center speaker, if desired. The amplitude of the signal obtained from these terminals is dependent upon the instantaneous phase of the signals in the Left and Right Channels, relative to each other. It is maximum when these signals happen to be in phase. If they happen to be out

of phase, and equal in amplitude, it is zero. Because this signal represents an adding of in-phase signals in the two channels, a center speaker carrying this signal tends to fill in the "hole-in-the-middle" effect present in some stereo material. In lieu of a center speaker, the SEPARATION control may be used to accomplish essentially the same effect. The CENTER SPEAKER terminals may instead be used to feed monophonic signal to a speaker in a remote location, such as another room. Satisfactory sound will be obtained from both stereo and monophonic sources.

Just ahead of the LEFT CHANNEL OUTPUT terminals is a phase-reversal switch, labelled LEFT PHASE. The switch is located on the rear chassis apron, and permits instant phase reversal if you are in doubt as to the correct phasing of speakers or stereo source material.

### CONSTRUCTION NOTES

The HEATHKIT Model AA-100 Stereo Amplifier, when constructed in accordance with the instructions in this manual, is a high quality amplifier capable of many years of trouble-free service. We urge you to take the necessary time to assemble and wire the kit carefully. Do not hurry the work and you will be rewarded with a greater sense of confidence, both in your amplifier and in your own ability.

This manual is supplied to assist you in every way to complete your kit with the least possible chance for error. The arrangement shown is the result of extensive experimentation and trial. If followed carefully, the result will be a stable instrument, operating at a high degree of dependability. We suggest that you retain the manual in your files for future reference, both in the use of the instrument and for its maintenance.

UNPACK THE KIT CAREFULLY AND CHECK EACH PART AGAINST THE PARTS LIST. In so doing, you will become acquainted with the parts. Refer to the charts and other information on the

In the power supply section, V-13, a type GZ-34 full-wave RECTIFIER tube, supplies all plate supply voltages. Decoupling and ripple filtering is accomplished by filter capacitors C-48 and C-49, in conjunction with resistors R-99 through R-102, inclusive. Separate 6.3 volt windings on the power transformer supply heater voltages to the tubes in the two channels. Each winding has a HUM-BALANCE control, permitting each channel to be individually optimized for lowest hum. A voltage divider consisting of R-96 and R-97 places a positive DC potential on the tube heaters. This eliminates hum-producing heater-to-cathode emission in tubes.

Two 117 volt power receptacles are provided on the rear chassis apron. One of these supplies power independently of the AA-100 POWER switch; the other is switched off and on with the AA-100. The primary of the power transformer is fused with a 2-ampere slow-blow fuse.

inside covers of the manual to help you identify the components. If some shortage or parts damage is found in checking the Parts List, please read the REPLACEMENT section and supply the information called for therein. Include all inspection slips in your letter to us.

In order to expedite delivery to you, we are occasionally forced to make minor substitution of parts. Such substitutions are carefully checked before they are approved and parts supplied will work satisfactorily. In checking the Parts List for resistors, for example, you may find that a resistor with a 5% tolerance has been substituted for a resistor with a 10% tolerance, as shown in the Parts List. These changes are self-evident and are mentioned here only to prevent confusion in checking the contents of your kit.

Resistors generally have a tolerance rating of 10% unless otherwise stated in the Parts List. Tolerances on capacitors are generally even greater. Limits of +100% and -50% are common for electrolytic capacitors.



## PARTS LIST

| <u>PART No.</u>  | <u>PARTS Per Kit</u> | <u>DESCRIPTION</u>                                     | <u>PART No.</u>            | <u>PARTS Per Kit</u> | <u>DESCRIPTION</u>   |
|------------------|----------------------|--|----------------------------|----------------------|--|
| <u>Resistors</u> |                      |  | <u>Resistors (Cont'd.)</u> |                      |  |
| 1-9              | 8                    | 1 K $\Omega$ 1/2 watt<br>(brown-black-red)             | 4-1                        | 4 ✓                  | 2.2 K $\Omega$ 1/2 watt low noise<br>(red-red-red or marked)             |
| 1-11             | 6                    | 1.5 K $\Omega$ 1/2 watt<br>(brown-green-red)           | 4-2                        | 2 ✓                  | 100 K $\Omega$ 1/2 watt low noise<br>(brown-black-yellow or<br>marked)   |
| 1-18             | 1                    | 5.6 K $\Omega$ 1/2 watt<br>(green-blue-red)            | 4-3                        | 2 ✓                  | 330 K $\Omega$ 1/2 watt low noise<br>(orange-orange-yellow or<br>marked) |
| 1-20             | 4                    | 10 K $\Omega$ 1/2 watt<br>(brown-black-orange)         |                            |                      |  |
| 1-22             | 1                    | 22 K $\Omega$ 1/2 watt<br>(red-red-orange)             |                            |                      |  |
| 1-23             | 2                    | 27 K $\Omega$ 1/2 watt<br>(red-violet-orange)          |                            |                      |  |
| 1-24             | 2                    | 33 K $\Omega$ 1/2 watt<br>(orange-orange-orange)       |                            |                      |  |
| 1-25             | 5                    | 47 K $\Omega$ 1/2 watt<br>(yellow-violet-orange)       |                            |                      |  |
| 1-26             | 6                    | 100 K $\Omega$ 1/2 watt<br>(brown-black-yellow)        |                            |                      |  |
| 1-29             | 2                    | 220 K $\Omega$ 1/2 watt<br>(red-red-yellow)            |                            |                      |  |
| 1-31             | 1                    | 330 K $\Omega$ 1/2 watt<br>(orange-orange-yellow)      |                            |                      |  |
| 1-33             | 6                    | 470 K $\Omega$ 1/2 watt<br>(yellow-violet-yellow)      |                            |                      |  |
| 1-35             | 6                    | 1 megohm 1/2 watt<br>(brown-black-green)               |                            |                      |  |
| 1-37             | 2                    | 2.2 megohm 1/2 watt<br>(red-red-green)                 |                            |                      |  |
| 1-44             | 2                    | 2.2 K $\Omega$ 1/2 watt<br>(red-red-red)               |                            |                      |  |
| 1-58             | 4                    | 22 K $\Omega$ 1/2 watt 5%<br>(red-red-orange-gold)     |                            |                      |  |
| 1-60             | 2                    | 68 K $\Omega$ 1/2 watt<br>(blue-gray-orange)           |                            |                      |  |
| 1-68             | 2                    | 820 K $\Omega$ 1/2 watt<br>(gray-red-yellow)           |                            |                      |  |
| 1-114            | 1                    | 8.2 K $\Omega$ 1/2 watt 5%<br>(gray-red-red-gold)      |                            |                      |  |
| 1-116            | 2                    | 6.2 K $\Omega$ 1/2 watt 5%<br>(blue-red-red-gold)      |                            |                      |  |
| 1-122            | 1                    | 3.3 K $\Omega$ 1/2 watt 5%<br>(orange-orange-red-gold) |                            |                      |  |
| 1A-17            | 2                    | 100 $\Omega$ 1 watt<br>(brown-black-brown)             |                            |                      |  |
| 1B-15            | 1                    | 1 K $\Omega$ 2 watt<br>(brown-black-red)               |                            |                      |  |
| 1B-1             | 1                    | 2.7 K $\Omega$ 2 watt<br>(red-violet-red)              |                            |                      |  |
| 3J-11            | 1 ✓                  | 1500 $\Omega$ 10 watt 10%<br>wire-wound                |                            |                      |  |
|                  |                      |  |                            |                      | <u>Controls-Switches</u>   |
|                  |                      |  | 10-52                      | 2 ✓                  | 2 K $\Omega$ control (tab mtg.)  |
|                  |                      |  | 10-103                     | 2 ✓                  | 1 megohm control (tab mtg.)  |
|                  |                      |  | 12-27                      | 2 ✓                  | Dual concentric control,<br>1 megohm both sections                       |
|                  |                      |  | 12-28                      | 1 ✓                  | Dual concentric control,<br>front - 20 K $\Omega$ , rear - 1 meg-<br>ohm |
|                  |                      |  | 12-26                      | 1 ✓                  | 1 megohm tandem control  |
|                  |                      |  | 13-3                       | 3 ✓                  | Triple control, 250 K $\Omega$<br>each section                           |
|                  |                      |  | 60-2                       | 1 ✓                  | DPDT slide switch  |
|                  |                      |  | 63-249                     | 1 ✓                  | SPST AC snap switch  |
|                  |                      |  | 63-247                     | 1 ✓                  | Printed circuit board rotary<br>switch, 6-position, 4-section            |
|                  |                      |  | 63-248                     | 1 ✓                  | Printed circuit board rotary<br>switch, 4-position, 1-section            |
|                  |                      |  |                            |                      | <u>Capacitors</u>  |
|                  |                      |  | 20-76                      | 4 ✓                  | 68 $\mu$ f $\pm$ 5% mica   |
|                  |                      |  | 21-31                      | 3 ✓                  | .02 $\mu$ f disc ceramic   |
|                  |                      |  | 21-47                      | 2 ✓                  | .01 $\mu$ f disc ceramic   |
|                  |                      |  | 23-2                       | 2 ✓                  | .005 $\mu$ f 600 V molded<br>tubular                                     |
|                  |                      |  | 23-28                      | 2 ✓                  | .1 $\mu$ f 200 V molded tubular  |
|                  |                      |  | 23-41                      | 1 ✓                  | .01 $\mu$ f 600 V molded tubular   |
|                  |                      |  | 23-42                      | 2 ✓                  | .015 $\mu$ f 600 V molded<br>tubular                                     |
|                  |                      |  | 23-50                      | 4 ✓                  | .022 $\mu$ f 400 V molded<br>tubular                                     |
|                  |                      |  | 23-52                      | 4 ✓                  | .047 $\mu$ f 400 V molded<br>tubular                                     |
|                  |                      |  | 23-53                      | 12 ✓                 | .1 $\mu$ f 400 V molded tubular  |
|                  |                      |  | 23-59                      | 2 ✓                  | .05 $\mu$ f 200 V molded<br>tubular                                      |
|                  |                      |  | 25-19                      | 1 ✓                  | 20 $\mu$ f 150 V tubular elec-<br>trolytic                               |
|                  |                      |  | 25-52                      | 1 ✓                  | 40-40-20 at 450 V-350 V-350<br>V twist prong mtg. electro-<br>lytic      |
|                  |                      |  | 25-55                      | 2 ✓                  | 50 $\mu$ f 10 V tubular electro-<br>lytic                                |



| PART No.  | PARTS Per Kit | DESCRIPTION   |
|---|---------------|---|
| <u>Capacitors (Cont'd.)</u>                         |               |   |
| 25-101  | 1             | 60-25 $\mu$ fd at 500 V-450 V twist prong mtg. electrolytic |
| <u>Transformers</u>                                 |               |   |
| 51-58   | 2             | Output  |
| 54-89   | 1             | Power   |
| <u>Circuit Boards-Sockets-Terminal Strips-Plugs</u> |               |   |
| 85-25F427   | 1             | Preamplifier circuit board                                  |
| 85-27F324   | 1             | Power amplifier circuit board                               |
| 431-5   | 1             | 4-lug terminal strip  |
| 431-7   | 1             | 6-screw terminal strip                                      |
| 431-17  | 1             | 5-screw terminal strip                                      |
| 434-2   | 1             | Octal socket  |
| 434-20  | 2             | 117 V power socket  |
| 434-21  | 4             | Pilot light socket  |
| 434-42  | 2             | Single phono socket   |
| 434-76  | 3             | Triple phono socket   |
| 434-78  | 2             | 9-pin molded socket (circuit board type) w/shield clip      |
| 434-79  | 6             | 9-pin molded socket (circuit board type)                    |
| 434-82  | 1             | Double phono socket   |
| 434-105   | 4             | Molded octal socket (circuit board type)                    |
| 438-4   | 10            | Single prong phono plug                                     |
| <u>Tubes-Lamps</u>                                  |               |   |
| 411-26  | 4             | 12AX7 tube  |
| 411-106   | 2             | EF-86 tube  |
| 411-133   | 2             | 7199 tube   |
| 411-136   | 1             | GZ-34/5AR4 tube   |
| 411-138   | 4             | 7591 tube   |
| 412-20  | 4             | #47 lamp  |
| <u>Hardware</u>                                     |               |   |
| 250-8   | 24            | #6 x 3/8" sheet metal screw                                 |
| 250-49  | 19            | 3-48 x 1/4" binder head machine screw (BHMS)                |
| 250-89  | 47            | 6-32 x 3/8" binder head machine screw (BHMS)                |
| 250-92  | 4             | 8-32 x 5/8" round head machine screw (RHMS)                 |
| 250-106   | 6             | 6-32 x 3/8" round head self-tapping screw                   |
| 250-138   | 2             | 6-32 x 3/16" binder head machine screw (BHMS)               |
| 250-172   | 5             | 3-48 x 3/8" pan head machine screw (PHMS)                   |
| 250-174   | 8             | 8-32 x 1/4" binder head machine screw (BHMS)                |
| 252-1   | 12            | 3-48 x 7/32" hex nut  |

| PART No.                                      | PARTS Per Kit | DESCRIPTION                                  |
|---|---------------|--|
| <u>Hardware (Cont'd.)</u>                     |               |  |
| 252-3   | 43            | 6-32 x 1/4" hex nut                          |
| 252-4   | 16            | 8-32 x 5/16" hex nut                         |
| 252-38  | 7             | 3/8" - 32 control nut (black finish)         |
| 253-10  | 6             | 5/8" control flat washer                     |
| 254-1   | 44            | #6 lockwasher                                |
| 254-2   | 15            | #8 lockwasher                                |
| 254-4   | 6             | Control lockwasher                           |
| 254-7   | 12            | #3 lockwasher                                |
| 255-35  | 6             | 11/16" phenolic spacer                       |
| 255-41  | 8             | 1/4" spacer                                  |
| 255-47  | 4             | .698 (approx. 11/16") x 3/8" spacer          |
| 259-2   | 1             | #8 solder lug                                |
| 259-6   | 1             | #6 solder lug                                |
| 259-11  | 1             | Spade lug                                    |
| <u>Cabinet-Chassis-Associated Metal Parts</u> |               |  |
| 90-M161                                       | 1             | Cabinet shell                                |
| 200-M283F436                                  | 1             | Chassis                                      |
| 203-M224F435                                  | 1             | Front panel                                  |
| 203-M225F430                                  | 1             | Control panel cover                          |
| 203-M226                                      | 1             | Front bottom subpanel                        |
| 204-M365                                      | 1             | Control mounting bracket                     |
| 204-M366                                      | 1             | Front panel support bracket left-hand        |
| 204-M367                                      | 1             | Front panel support bracket right-hand       |
| 204-M369                                      | 1             | Input socket mounting bracket                |
| 204-M370                                      | 1             | Chassis support bracket                      |
| 205-M268F423                                  | 1             | Bottom plate                                 |
| 210-14  | 1             | Front bezel                                  |
| <u>Knobs</u>                                  |               |  |
| 462-117                                       | 1             | Small, for flatted 1/4" shaft                |
| 462-118                                       | 3             | Large, for keyed sleeve                      |
| 462-119                                       | 3             | Small, for flatted 3/16" shaft               |
| 462-124                                       | 3             | Large, for flatted 1/4" shaft                |
| <u>Miscellaneous</u>                          |               |  |
| 57-22   | 1             | Selenium rectifier                           |
| 73-2  | 1             | Rubber grommet (large)                       |
| 73-3  | 5             | Rubber grommet (small)                       |
| 75-20   | 1             | Double phono socket insulator                |
| 75-24   | 1             | Line cord strain relief                      |
| 75-41   | 1             | Triple phono socket insulator                |
| 84-13   | 2             | Packaged electronic circuit (P.E.C. network) |

- step. In any case where there is the possibility of an unintentional short circuit, sleeving should be used. Extra sleeving is provided for this purpose.
5. Crimp or bend the lead (or leads) around the terminal to form a good joint without relying on solder for physical strength. If the wire is too large to allow bending or if the step states that the wire is not to be crimped, position the wire so that a good solder connection can still be made.
  6. Position the work, if possible, so that gravity will help to keep the solder where you want it.
  7. Place a flat side of the soldering iron tip against the joint to be soldered until it is heated sufficiently to melt the solder.

8. Then place the solder against the heated terminal and it will immediately flow over the joint; use only enough solder to thoroughly wet the junction. It is usually not necessary to fill the entire hole in the terminal with solder.
9. Remove the solder and then the iron from the completed junction. Use care not to move the leads until the solder is solidified.

A poor or cold solder joint will usually look crystalline and have a grainy texture, or the solder will stand up in a blob and will not have adhered to the joint. Such joints should be reheated until the solder flows smoothly over the entire junction. In some cases, it may be necessary to add a little more solder to achieve a smooth bright appearance.

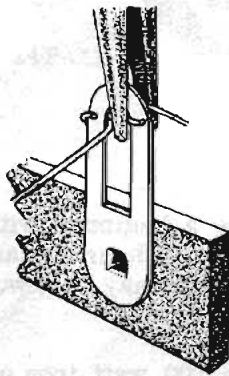

CRIMP WIRES

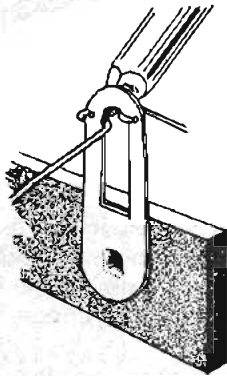

HEAT CONNECTION

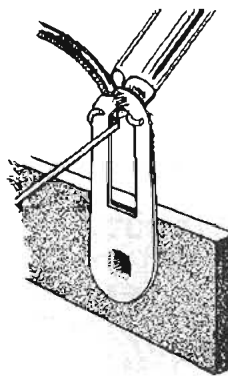

APPLY SOLDER

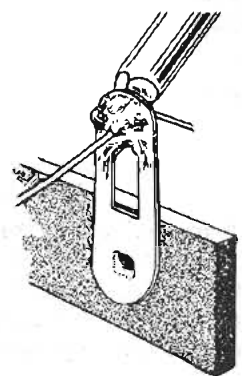

ALLOW SOLDER TO FLOW

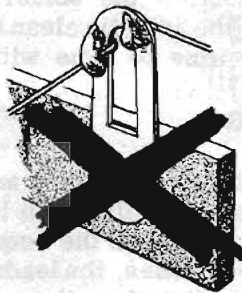

COLD SOLDER JOINT CONNECTION INSUFFICIENTLY HEATED

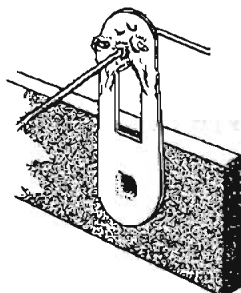

PROPER SOLDER CONNECTION

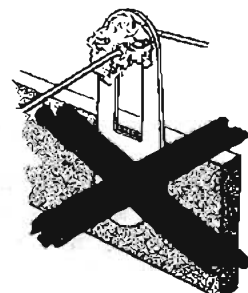

COLD SOLDER JOINT CONNECTION MOVED WHILE COOLING

NOTE: ALL GUARANTEES ARE VOIDED AND WE WILL NOT REPAIR OR SERVICE INSTRUMENTS IN WHICH ACID CORE SOLDER OR PASTE FLUXES HAVE BEEN USED. WHEN IN DOUBT ABOUT SOLDER, IT IS RECOMMENDED THAT A NEW ROLL PLAINLY MARKED "ROsin CORE RADIO SOLDER" BE PURCHASED.

The HEATHKIT Model AA-100 is a complex instrument. We very strongly urge that you follow wiring and parts layout shown in the manual. The positions of some of the wires are quite critical and changes may result in increased hum level or other undesirable performance characteristics. Special instructions regarding se-

quence of assembly and lead lengths are given to make construction of this kit as easy as possible. Wiring and mounting parts improperly may result in performance deficiencies and it may be necessary to redo work previously accomplished.

### CIRCUIT BOARD WIRING AND SOLDERING

Before attempting any work on the circuit boards, read the following instructions carefully and study Figures 3 and 4. It is only necessary to observe a few basic precautions which will insure proper operation of the unit the first time it is turned on.

Proper mounting of components on the board is essential for good performance. A good general rule to follow is that all components on the board should be mounted tightly to the board, unless instructions state otherwise. All leads should be kept as short as possible to minimize the effects

of stray capacity in the wiring. Proper and improper methods of mounting are illustrated in Figures 3 and 4.

Tubular capacitor and resistors will fit properly if the leads are bent, as shown in the accompanying figures. Disc capacitors will generally fit in place with no lead preparation other than determining that the leads are straight. Components with lugs normally require no preparation unless the lugs appear to be bent, in which case they can be straightened with pliers.

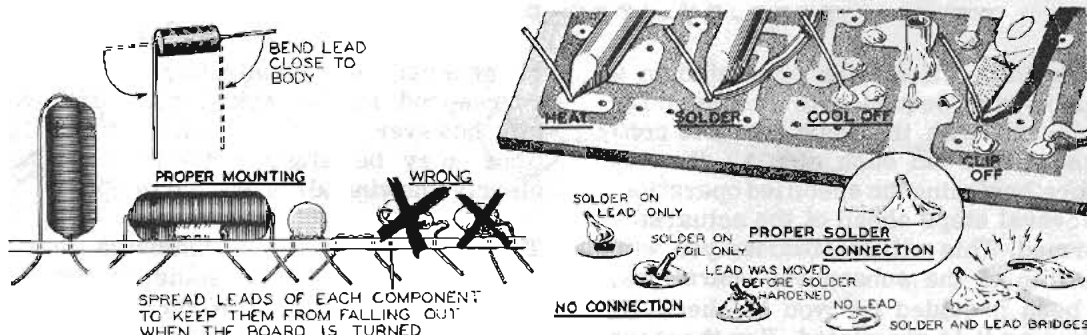

Figure 3

Parts should be inserted as instructed, and the leads bent outward slightly, as illustrated, to lock them in place.

Components will be soldered in groups; after a group of components have been installed, instructions will be given to solder them. When the components have been soldered, diagonal cutters may be used to cut off the excess leads close to the board.

The actual technique of soldering leads to a circuit board is quite simple. Position the tip of the soldering iron so that it firmly contacts both the circuit board foil and the wire, or lug, to be soldered, as shown in Figure 3. Then the solder should immediately be placed between the iron and the joint to be soldered. Remove the solder as

soon as it begins to melt and flow onto the lead and foil. Hold the tip of the iron in place only until the solder begins to flow outward over the foil; then remove the iron quickly.

Avoid overheating the connection. A soldering pencil or small iron (approximately 30 watts) is ideal for use in circuit board work. If a high wattage iron or soldering gun must be used, precautions must be taken to avoid circuit board damage due to overheating.

The use of an excessive amount of solder will increase the possibility of bridging between foil conductors or plugging holes which are to be left open for wires which may be added later on.

If solder is accidentally bridged across insulating areas between conductors, it can be cleaned off by heating the connection carefully and quickly wiping the solder away with a soft cloth. Holes which become plugged can be cleared by heating the area immediately over the hole and gently pushing the lead of a resistor through the hole from the opposite side, and withdrawing the lead before the solder rehardens. Do not force

the wire through; too much pressure before the solder has time to soften may separate the foil from the board.

In cases where foil does become damaged, repairs can usually be made with little difficulty. A break in the foil can be rejoined with a small piece of bare wire soldered across the gap, or between the foil and the lead of a component.

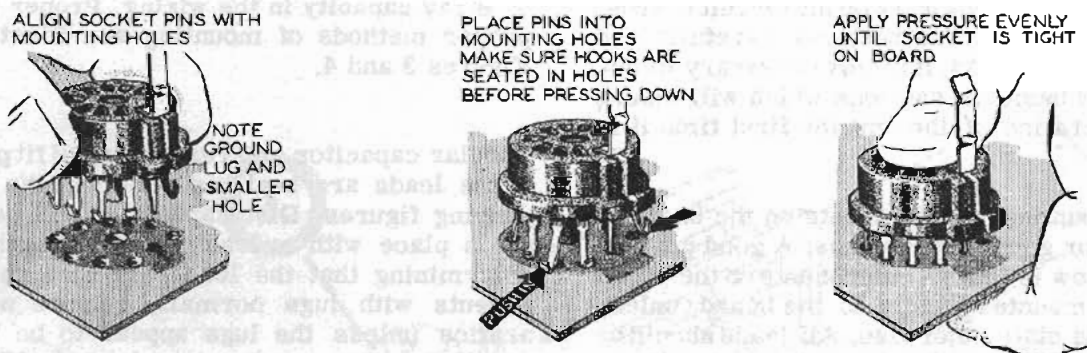

Figure 4

### STEP-BY-STEP PROCEDURE

The following instructions are presented in a logical step-by-step sequence to enable you to complete your kit with the least possible confusion. Be sure to read each step all the way through before beginning the specified operation. Also read several steps ahead of the actual step being performed. This will familiarize you with the relationship of the subsequent operations. Space has been provided for you to check off each operation as it is completed. For the steps that are contained in boxes on the illustrations, there will be a number before each of these spaces which will indicate the order in which the steps are to be performed. This check is particularly important in wiring and it may prevent omissions or errors, especially if your work is interrupted frequently as the wiring progresses. Some kit builders have also found it helpful to mark each lead or component in colored pencil on the pictorial as it is added.

The fold-out diagrams in this manual may be removed and attached to the wall above your working area; but, because they are an integral part of the instructions, they should be returned to the manual after the kit is completed.

In general, the illustrations in this manual correspond to the actual configuration of the kit; however, in some instances the illustrations may be slightly distorted to facilitate clearly showing all of the parts.

The abbreviation "NS" indicates that a connection should not be soldered yet as other wires will be added. When the last wire is installed, the terminal should be soldered and the abbreviation "S" is used to indicate this. Note that a number will appear after each solder instruction. This number indicates the number of leads that are supposed to be connected to the terminal in point before it is soldered. For example, if the instruction reads, "Connect a lead to lug 1 (S-2)," it will be understood that there will be two leads connected to the terminal at the time it is soldered. (In cases where a lead passes through a terminal or lug and then connects to another point, it will count as two leads, one entering and one leaving the terminal.)

The steps directing the installation of resistors include color codes to help identify the parts. Also, if a part is identified by a letter-number designation on the Schematic, its designation will appear in the construction step which directs its installation.



## STEP-BY-STEP ASSEMBLY

ASSEMBLY OF PREAMPLIFIER CIRCUIT BOARD (Part #85-25F427)

Refer to Figure 5 (fold-out from Page 17) for the following steps:

- ( ) Install two 9-pin tube sockets (#434-78, with shield clip) at locations V1 and V2. See also Figure 4. On each socket, solder all ten connections and the center post to the foil.
- ( ) Install four 9-pin tube sockets (#434-79) at locations V3, V4, V5 and V6. Solder all nine connections on each socket.

**NOTE:** Do not use any yellow or black hookup wire until specifically called for. Continue the assembly of the preamplifier circuit board by performing steps 3 through 82 shown on Figure 5.

Refer to Figure 6 (fold-out) for the following six steps.

- ( ) Install **MODE SELECTOR** switch #63-248.
  1. Solder all five prongs. Note procedure in Detail 6A. Hold switch wafer perpendicular to circuit board while soldering.

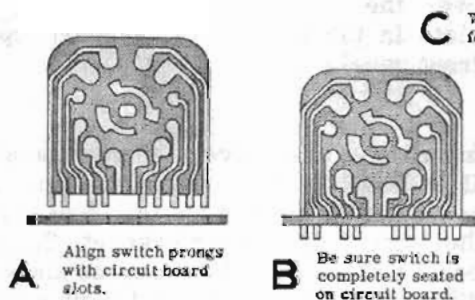

**C** Work on side of foil isle only.

Detail 6A

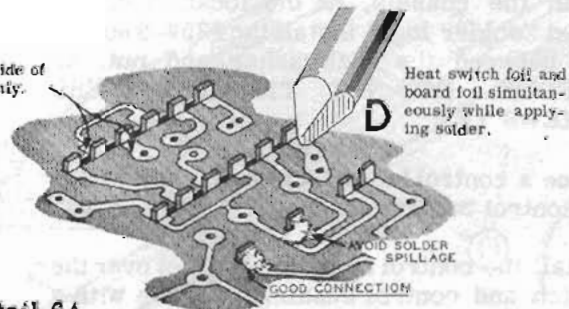
ASSEMBLY OF POWER AMPLIFIER CIRCUIT BOARD (Part #85-27F324)

- ( ) Install two 9-pin tube sockets (#434-79) V7 and V8. Solder all nine connections on each socket.

**IMPORTANT:** In the following step, each socket must be positioned with its keyway in the direction shown by the circuit board markings.

- ( ) Install the **SOURCE SELECTOR** switch #63-247. Solder all thirty-three prongs.

**NOTE:** Be sure to identify all four controls properly, before mounting.

- ( ) Install **BALANCE/SEPARATION** control #12-28. Solder all six prongs.
- ( ) Install dual **VOLUME** control #12-26. Solder all six prongs.
- ( ) Install **LEFT CHANNEL TONE** control #12-27. Solder all six prongs.
- ( ) Install **RIGHT CHANNEL TONE** control #12-27. Solder all six prongs.

- ( ) Lay the assembled circuit board aside temporarily, and proceed with assembly of the power amplifier circuit board.

- ( ) Install four octal (8-pin) tube sockets (#434-105) V9, V10, V11 and V12. Solder the eight connections on each socket.

Starting with step #3, install the remaining components as shown in Figure 7.



### INSTALLATION OF PREAMPLIFIER CIRCUIT BOARD AND FRONT PANEL

Refer to Figure 8 for the following steps.

( ) Secure the front chassis flange with two  
1. #6 sheet metal screws, one on each side of the chassis.

( ) Install two POWER AMPLIFIER INPUT  
2. LEVEL controls #10-103. Be sure to position controls as shown.

( ) Install two electrolytic capacitor mounting  
3. wafers on top of chassis.

( ) Place the preamplifier circuit board on top  
4. of the chassis in the position shown. Use 3-48 x 3/8" screws in the five holes along the rear of the circuit board. Under the chassis, mount the chassis support bracket over the same screws, then use a #3 lockwasher and a 3-48 nut on each screw. DO NOT TIGHTEN YET.

( ) Install 3-48 x 1/4" screws in the seven  
5. remaining mounting holes of the circuit board. As before, use #3 hardware underneath the chassis. At the location designated "solder lug," install the #259-6 solder lug between the lockwasher and nut. AS BEFORE, DO NOT TIGHTEN THESE SCREWS YET.

( ) Place a control lockwasher over each switch  
6. or control bushing.

( ) Install the control mounting bracket over the  
7. switch and control bushings. Secure with a 5/8" flat washer and a control nut on each bushing.

( ) Install the front panel with painted side out.  
8. Use four self-tapping screws, inserted from the underside of the chassis. Note: Since these screws actually cut threads in the panel mounting holes, you will find that they turn somewhat harder than ordinary machine screws.

NOTE: Now proceed to Figure 8A and perform the steps accompanying it.

( ) Mount the right-hand and left-hand panel  
9. brackets to the chassis with 6-32 x 3/8" BHMS, #6 lockwashers, and 6-32 nuts. Do not secure the upper portion of either bracket yet.

( ) Mount the front bottom subpanel to the  
10. front of the chassis.

( ) Mount the AC power switch. Be sure to  
11. orient the switch so that its locating lug is in the slot.

( ) Install the decorative cover over the front  
12. bottom subpanel, as shown in the detail.

( ) Using a 6-32 self-tapping screw, prethread  
13. the four holes indicated: two in the front panel and two in the bezel.

( ) Install the plastic front panel window by  
14. first inserting the bottom edge as shown in the detail. Then swing the top of the window over the front panel and engage the four slots in the four projections on top of the front panel.

( ) Install the bezel over the panel assembly.  
15. **IMPORTANT:** The mounting tabs on the bezel **MUST** be between the front panel and the control mounting bracket. Secure the bezel with four 6-32 screws as shown (note different lengths), inserted from behind the panel assembly. Tighten securely, but do not overtighten, as the threads in the aluminum parts are relatively easy to strip.

( ) Now tighten the twelve 3-48 screws holding  
16. the large circuit board.

NOTE: Now proceed to Figure 9 and perform the 9 steps accompanying it.

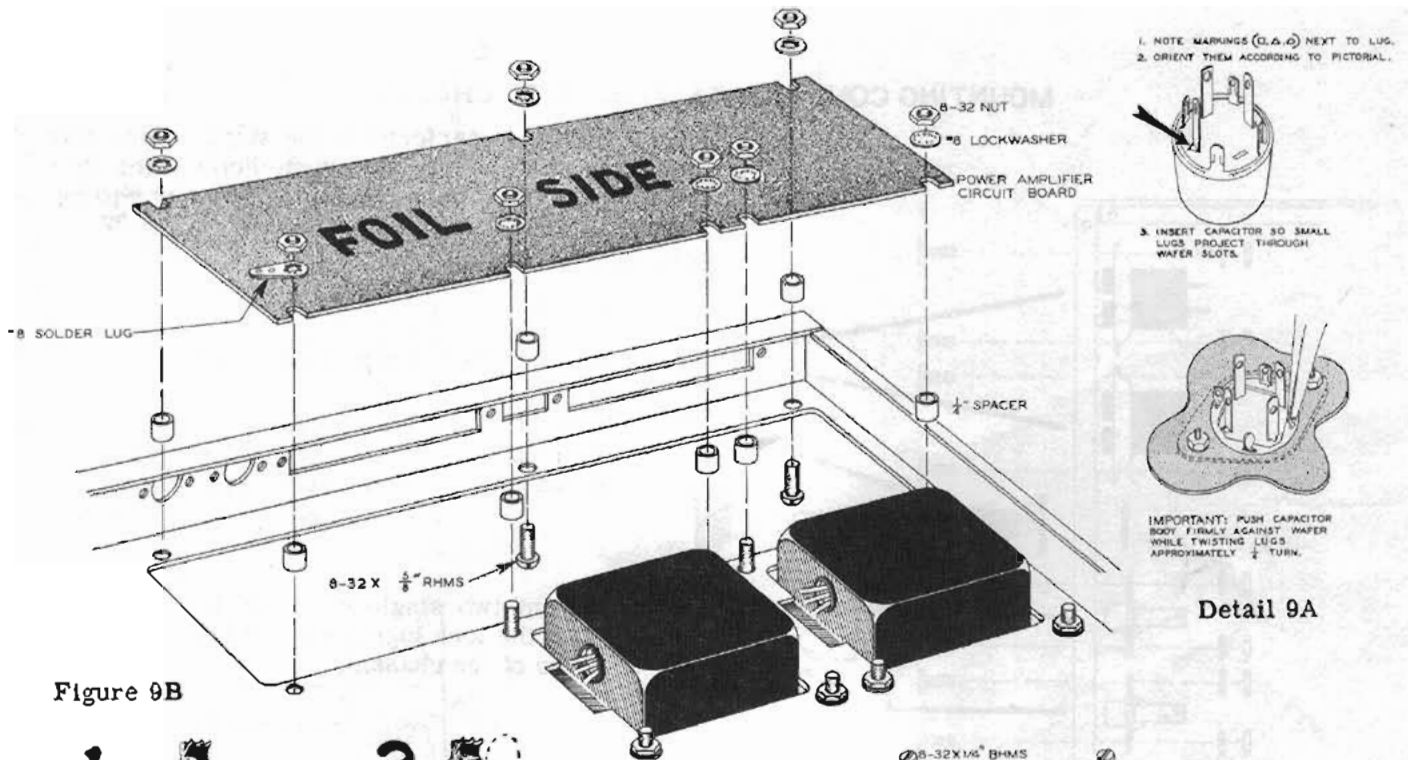
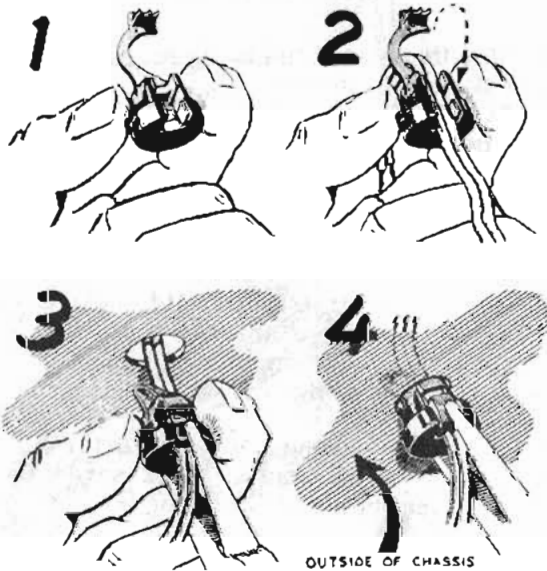

Figure 9B



Detail 10A

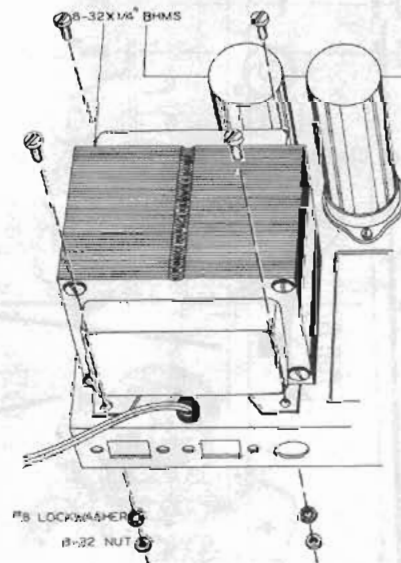

Figure 10

- ( ) Refer to Figure 9B and mount the power amplifier circuit board on the underside of the chassis. Note that a #8 solder lug is used instead of a lockwasher near one corner of the board.
- ( ) As shown in Detail 10A, install the line cord strain relief at a point 2-1/2" from the end of the line cord.

- ( ) Press strain relief into hole in chassis. See Figure 10.
- ( ) Install the power transformer on top of the chassis by first passing its leads through the rubber grommet. Secure with four 8-32 x 1/4" binder head screws, #8 lockwashers and nuts. See Figure 10.

## MOUNTING COMPONENTS ON REAR OF CHASSIS

**IMPORTANT:** In performing the steps below, note that some parts are to be mounted on the inside of the rear chassis flange, while others are to be mounted on the outside. In all cases, use 6-32 hardware, as shown.

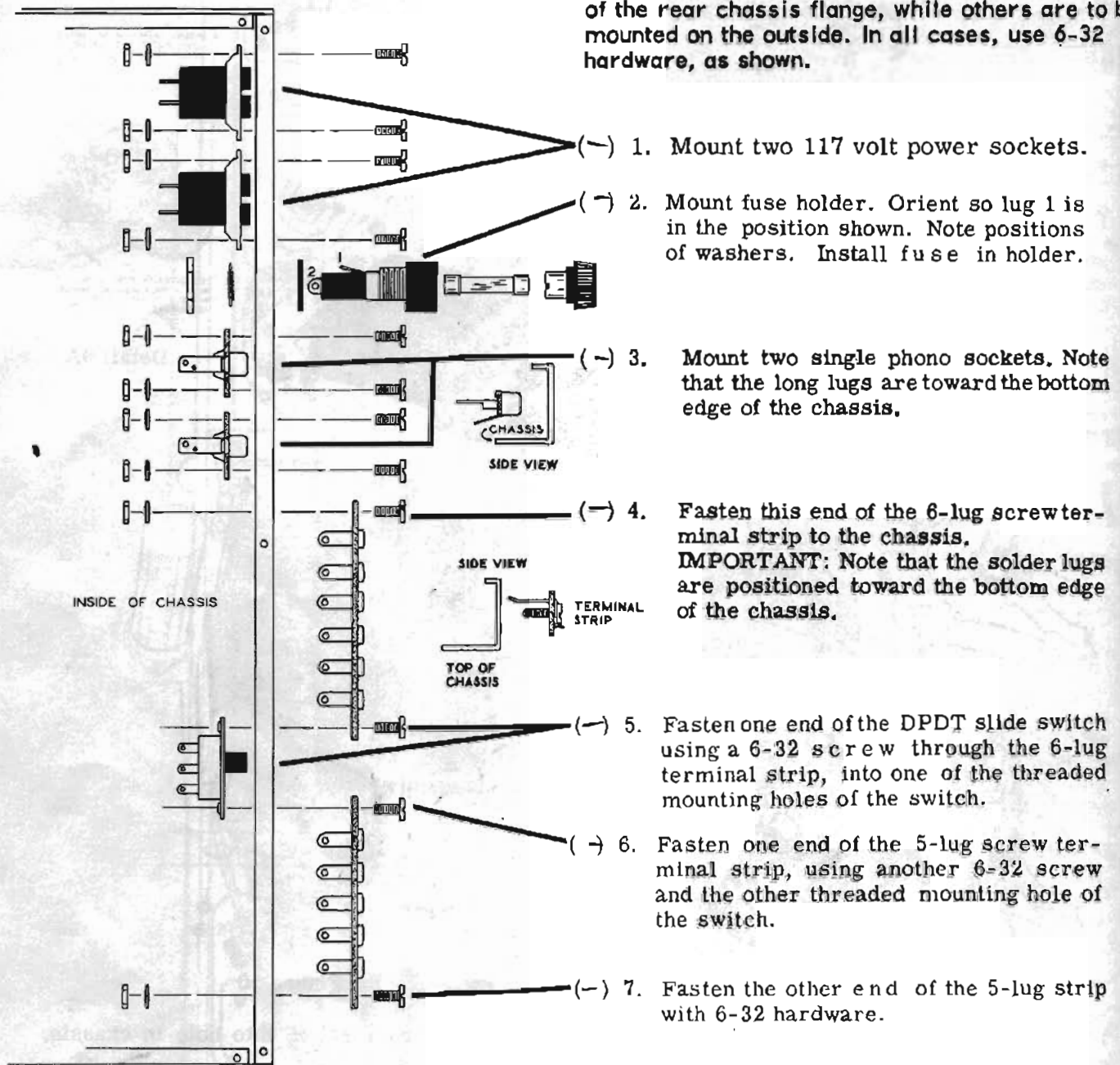

Figure 11

## CHASSIS WIRING

Refer to Figure 12 (fold-out from Page 22). Due to the large number of wires and components, the latter are shown in Detail 12A, to avoid an overcrowded illustration. In the following step-by-step instructions, refer to the appropriate illustration.

- ( ) Identify the red-yellow power transformer lead and connect it to lug 1 of capacitor D (S-1). **IMPORTANT:** Do not cut this or the remaining power transformer leads.
  - ( ) Identify the red-green power transformer lead and connect it to lug 3 of terminal strip F (NS).
  - ( ) Identify the 1.5 K $\Omega$  10 watt wire-wound resistor and slip a 3/4" length of sleeving over each lead. Position the resistor against the chassis and connect one end to lug 8 of socket C (NS). Connect the other end to the  $\blacktriangle$  marked lug of capacitor D (NS).
  - ( ) Twist together the two yellow power transformer leads. Connect either lead to lug 2 of socket C (S-1). Connect the other lead to lug 8 of socket C (NS).
  - ( ) Twist together the two red power transformer leads and connect either lead to lug 4 of socket C (S-1). Connect the other lead to lug 6 of socket C (S-1).
  - ( ) Dress the yellow and red twisted leads as shown.
- NOTE: Use the yellow and black hookup wire only when specifically called for.
- ( ) Cut a 4" length of hookup wire and remove 1/4" of insulation from each end. Connect this wire between lug 4 of terminal strip F (NS) and lug 2 of capacitor D (NS).
  - ( ) Similarly, prepare a 3" wire and connect between hole 44 on the small circuit board (S-1) and solder lug L (NS).
  - ( ) In the same manner, prepare a 5-1/2" length of hookup wire. Connect between lug 2 of capacitor D (S-2) and hole 43 on the power amplifier (small circuit board) (S-1).
  - ( ) Prepare a 6-1/4" wire and connect between hole 42 on the small circuit board (S-1) and the  $\blacktriangle$  marked lug of capacitor D (NS).
  - ( ) Prepare a 3-1/4" wire and connect between lug 8 of socket C (S-3) and the  $\blacktriangle$  marked lug of capacitor D (NS). Dress wire as shown.
  - ( ) Identify the red lead of output transformer P. Route this lead as shown and connect to the  $\blacktriangle$  marked lug of capacitor D (NS).
  - ( ) On output transformer Q, cut the red lead to a length of 6-3/4". Remove 1/4" of insulation, twist the exposed strands together, and apply a small amount of solder to the bare end. (This is called "Tinning.") Route this wire as shown, and connect the end to the  $\blacktriangle$  marked lug of capacitor D (S-3).
  - ( ) Prepare an 11" length of wire and connect one end to lug 2 of capacitor E (S-1). Route the wire as shown, and pass the other end through grommet AD. Connect this end to hole 20 on the preamplifier (large circuit board) (NS).
  - ( ) Prepare a 9" wire and connect one end to hole 33 on the small circuit board (S-1). Route as shown and connect the other end to the  $\blacktriangle$  marked lug of capacitor E (NS).
  - ( ) Prepare a 5" wire and connect one end to hole 40 of the small circuit board (S-1). Connect the other end to lug 1 of terminal strip F (NS).
  - ( ) Prepare a 12-3/4" wire and connect one end to hole 23 on the large circuit board (S-1). Pass the other end through grommet AD and connect it to the  $\blacktriangle$  marked lug on capacitor E (NS).
  - ( ) Prepare a 9-3/4" wire and connect one end to hole 24 on the large circuit board (S-1). Pass the other end through grommet AD and connect it to the  $\blacksquare$  marked lug of capacitor E (NS).
  - ( ) Slip a 1/2" length of sleeving over one lead of a 22 K $\Omega$  resistor (red-red-orange). Connect this lead to lug 2 of control T (NS). Connect the other lead to lug 3 of capacitor E (NS). Position resistor as shown.

- ( ) Slip a 1/2" length of sleeving over one lead of a .02  $\mu$ fd ceramic capacitor. Connect this end to lug 2 of control T (NS), and the other end to lug 3 of capacitor E (S-2).
- ( ) Prepare a 1-1/2" length of wire and connect between lug 2 of control T (S-3) and lug 2 of control U (NS).
- ( ) Twist together the two green power transformer leads. Connect either lead to lug 1 (NS) and the other lead to lug 3 (NS) of control U.
- ( ) Connect a 330 K $\Omega$  resistor (orange-orange-yellow) between lug 2 of control U (S-2) and the  $\blacksquare$  lug of capacitor E (NS).
- ( ) Install a 1 K $\Omega$  2 watt resistor (brown-black-red) between the  $\blacktriangle$  lug of capacitor D (S-3) and the  $\blacktriangle$  lug of capacitor E (NS). Position the resistor body so its axis is approximately 1/2" from the chassis.
- ( ) Install a 2.7 K $\Omega$  2 watt resistor (red-violet-red) between the  $\blacktriangle$  lug (S-3) and the  $\blacksquare$  lug (NS) of capacitor E.
- ( ) Install a 5.6 K $\Omega$  resistor (green-blue-red) between the  $\blacksquare$  lug (S-4) and the  $\blacktriangle$  lug (S-2) of capacitor E.
- ( ) Twist together the two brown power transformer leads and pass them under the 1 K $\Omega$  2 watt resistor. Connect either lead to lug 1 (NS) and the other lead to lug 3 (NS) of control T.
- ( ) At the end of each line cord conductor, twist the strands together and tin the ends. Connect either conductor to lug 1 of fuse holder J (NS).
- ( ) Connect the other line cord conductor to lug 2 of AC socket G (NS).
- ( ) Prepare a 1-1/4" wire and connect between lug 1 of fuse holder J (S-2) and lug 1 of socket H (NS).
- ( ) Prepare a 2-1/4" wire and connect between lug 1 of socket H (S-2) and lug 1 of socket G (S-1).
- ( ) Prepare a 13-5/8" and a 15" length of hook-up wire. Twist these two wires together after first positioning the wire ends even at one end of the pair. This is called a "twisted pair." As a guide to how tightly to twist the wires, refer to Detail 12B.
- ( ) At the end of the twisted pair having uneven ends, connect the longer wire to lug 2 of socket H (NS). Connect the shorter wire to lug 2 of socket G (S-2). Now dress the twisted pair exactly as shown in the Pictorial.
- ( ) Identify the length of spiral shielding and cut it to a length of 2-1/2". At one end, uncoil approximately 1/2" of wire. Slip this end over the free end of the twisted pair just installed, until the free ends protrude 3/4".
- ( ) Connect the uncoiled end of spiral shielding to solder lug B (S-1).
- ( ) Cut a 2-1/4" length of clear plastic sleeving and slip it over the spiral shielding.
- ( ) Connect either wire of the twisted pair to either lug on switch A (S-1), and the other wire to the remaining lug (S-1).

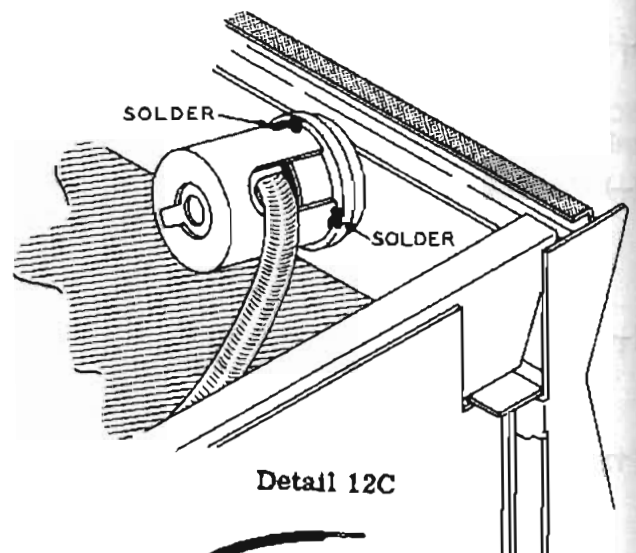

Detail 12B



- ( ) Slip the switch shield cover over the rear of switch A. Make sure the insulating liner is inside the cover. Solder the cover to the switch, as shown in Detail 12C. NOTE: Soldering will probably be easier if the metal is first scraped clean with a file or dull knife.
  - ( ) Install the .01  $\mu$ fd 600 V capacitor between lug 2 of fuse holder J (NS) and solder lug L (NS).
  - ( ) Twist together the two black power transformer leads. Connect either lead to lug 2 of the fuse holder J (S-2) and the other lead to lug 2 of socket H (S-2).
- IMPORTANT:** The electrolytic capacitor and selenium rectifier which will be installed in the following two steps must each be installed with correct polarity, or serious damage may result.
- ( ) Install the 20  $\mu$ fd 150 V tubular electrolytic capacitor (#25-19) by connecting the positive (+) lead to lug 4 of terminal strip F (NS), and the negative (-) lead to lug 2 of the same terminal strip (NS).
  - ( ) Install the selenium rectifier by connecting the + lead to lug 3 (S-2) and the other lead to lug 2 (NS) on terminal strip F.
  - ( ) Install the 8.2 K $\Omega$  5% resistor (gray-red-red-gold) between lug 1 (NS) and lug 2 (S-3) of terminal strip F.
  - ( ) Slip a 5/8" length of sleeving over each lead of the 3.3 K $\Omega$  5% resistor (orange-orange-red-gold) and connect the resistor between lug 1 (S-3) and lug 4 (S-3) of terminal strip F.
  - ( ) Connect the blue-yellow lead of output transformer Q to hole 37 on the small circuit board (S-1).
  - ( ) On the same transformer, cut the blue lead to a length of 3-1/2". Remove 1/4" of insulation from the end, twist the strands together and tin, then connect to hole 36 on the small circuit board (S-1).
  - ( ) Prepare a 3-1/2" length of hookup wire and connect between hole 39 on the small circuit board (S-1) and lug 8 on terminal strip M (NS).
  - ( ) Prepare a 1-3/4" wire and connect between hole 41 on the small circuit board (S-1) and lug 5 on terminal strip M (NS).
  - ( ) Prepare a 4" wire and connect between hole 38 on the small circuit board (S-1) and lug 3 on terminal strip M (NS).
  - ( ) Prepare two 4-1/2" wires and twist them together to form a twisted pair. At one end of the twisted pair, connect either wire to hole 34 (S-1) and the other wire to hole 35 (S-1) on the small circuit board. At the other end of the twisted pair, connect either wire to lug 1 (S-2) and the other wire to lug 3 (S-2) of control U.
  - ( ) Prepare two 8-1/4" wires and make another twisted pair. At one end, connect either wire to hole 31 (S-1) and the other wire to hole 32 (S-1) on the small circuit board. At the other end, connect either wire to lug 1 (S-2) and the other wire to lug 3 (S-2) on control T.
  - ( ) Connect the black lead from transformer Q to lug 6 of terminal strip M (S-2).
  - ( ) Connect the brown lead from transformer Q to lug 5 of terminal strip M (S-2).
  - ( ) Connect the green lead from transformer Q to lug 4 of terminal strip M (S-1).
  - ( ) Remove insulation from a 3/4" length of hookup wire and connect this between lugs 2 (S-1) and 3 (NS) of terminal strip M.
  - ( ) Connect the yellow lead from transformer Q to lug 3 of terminal strip M (S-3).
  - ( ) Cut the blue lead from transformer P to a length of 2-3/4". Remove 1/4" of insulation, tin the end, and connect to hole 28 on the small circuit board (S-1).
  - ( ) Cut the blue-yellow lead from transformer P to a length of 4-1/4". Prepare the end as before and connect to hole 27 on the small circuit board (S-1).
  - ( ) Connect the black lead from transformer P to lug 4 of slide switch N (NS).
  - ( ) Remove insulation from a 1-1/4" length of wire and connect between hole 30 of the small circuit board (S-1) and lug 5 of terminal strip O (NS).

- ( ) Prepare a 3" wire and connect between hole 26 on the small circuit board (S-1) and lug 4 on switch N (NS).
- ( ) Prepare a 3" wire and connect it between lug 5 of switch N (S-1) and lug 2 (S-1) of terminal strip O.
- ( ) Prepare a 1-1/2" wire and connect between lug 4 (S-3) and lug 3 (NS) of switch N.
- ( ) Prepare another 1-1/2" wire and connect between lug 6 (S-1) and lug 1 (NS) on switch N.
- ( ) Remove insulation from a 1" wire and connect between lug 3 of switch N (S-2) and lug 1 of terminal strip M (S-1).
- ( ) Remove insulation from a 1-1/2" wire and connect between hole 29 on the small circuit board (S-1) and lug 3 on terminal strip O (NS).
- ( ) Identify the short length of test lead wire; this is stranded wire with black rubber insulation. Cut this to a length of 4-1/2" and remove 3/16" of insulation from each end. Twist the strands together and tin the ends.
- ( ) As shown in Detail 12D, connect one end of this lead to the spade lug.

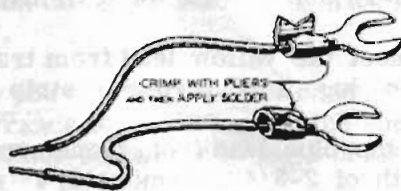

Detail 12D

- ( ) Pass the other end of this lead through the chassis hole above lug 5 of terminal strip O from the top of the chassis. Connect it to lug 1 on switch N (S-2). See Figure 12 (fold-out Page 22) and Figure 13 (fold-out Page 33).
- ( ) Prepare a 3-5/8" wire and connect between lug 2 on switch N (S-1) and lug 1 on terminal strip O (S-1).

- ( ) Connect the brown lead from transformer P to lug 5 of terminal strip O (S-2).
- ( ) Connect the green lead from the same transformer to lug 4 of terminal strip O (S-1).
- ( ) Connect the yellow lead from the same transformer to lug 3 of terminal strip O (S-2).

In each of the following steps, cut a wire of the indicated length, strip insulation as indicated, and solder one end to the indicated hole in the large circuit board, leaving the other end free for connection later, when the input level controls are installed.

| <u>LENGTH</u> | <u>REMOVE INSULATION</u> | <u>HOLE</u> |
|---------------|--------------------------|-------------|
| ( ) 1-1/2"    | 1/4" at each end         | 12          |
| ( ) 1-5/8"    | 1/4" at each end         | 14          |
| ( ) 1"        | remove all insulation    | 13          |
| ( ) 1"        | remove all insulation    | 15          |
| ( ) 1"        | remove all insulation    | 22          |
| ( ) 2-1/4"    | 1/4" at each end         | 6           |
| ( ) 1-1/4"    | 1/4" at each end         | 5           |
| ( ) 1"        | remove all insulation    | 4           |
| ( ) 1"        | remove all insulation    | 11          |
| ( ) 1-1/4"    | 1/4" at each end         | 10          |
| ( ) 1-3/4"    | 1/4" at each end         | 9           |
| ( ) 6" yellow | 1/4" at each end         | 17          |
| ( ) 6" black  | 1/4" at each end         | 18          |
|               | *twist together          |             |

- ( ) Cut a 12" length of yellow hookup wire and remove 1/4" of insulation from each end.
- ( ) Cut a 12" length of black hookup wire and remove 1/4" of insulation from one end only.

- ( ) Twist these wires together. At the end having no insulation removed from the black wire, connect the yellow wire to hole 18 on the large circuit board (S-1). Bend back the end of black wire at this end, so it cannot short circuit to the circuit board foil.
- ( ) Route this twisted pair exactly as shown, passing the other end through grommet AD. (The reason for this routing will be evident when the input socket bracket is installed later.) Connect the black wire to lug 2 (S-1) and the yellow wire to lug 1 (S-1) on phono socket K.
- ( ) In a similar manner, cut a 12-1/4" length of yellow wire and a 12-1/4" length of black wire. Remove 1/4" of insulation from each end of the yellow wire, and from one end of the black wire, and twist together.
- ( ) At the end having no insulation removed from the black wire, connect the yellow wire to hole 19 on the large circuit board (S-1). Bend back the end of black wire at this end so it cannot short circuit to the circuit board foil.
- ( ) Route this twisted pair exactly as shown, passing the other end through grommet AD. Connect the black wire to lug 2 (S-1) and the yellow wire to lug 1 (S-1) on phono socket L.

Refer to Figure 13 (fold-out from Page 33) and position the chassis as shown.

- ( ) Locate one of the pilot light sockets, a #47 lamp, and a small grommet.
  - ( ) Place the grommet on the socket as shown in Detail 13-1 and 13-2. The grommet will slide on the socket easier if it is wet.
  - ( ) Install the #47 lamp in the socket.
  - ( ) Referring to Figure 13, install the prepared pilot light socket at SA. The grommet should be pushed to the bottom of the slot at SA, and then the socket should be positioned in the grommet to the 3/8" dimension shown in Detail 13-2.
  - ( ) In the same manner, prepare and install pilot light sockets at SB, SC, and SD.
- NOTE: All circuit board connections made at this time will be soldered later.
- ( ) Prepare two 5-1/2" wires and make a twisted pair. At one end, connect either wire to either lug of pilot socket SD (S-1). Connect the other wire to the remaining lug on SD (S-1). At the other end of the twisted pair, connect either wire to either lug of pilot socket SC (NS) and the other wire to the remaining lug on SC (NS).
  - ( ) Prepare two 6-1/2" wires and make a twisted pair. At one end, connect either wire to either lug of pilot socket SC (S-2). Connect the other wire to the remaining lug on SC (S-2). At the other end of the twisted pair, insert the wires into holes LL on the large circuit board.
  - ( ) Prepare two 5-1/2" wires and make a twisted pair. At one end, connect either wire to either lug of pilot socket SB (S-1). Connect the other wire to the remaining lug on SB (S-1). At the other end of the twisted pair, connect either wire to either lug of pilot light socket SA (NS) and the other wire to the remaining lug on SA (NS).
  - ( ) Prepare two 6-1/2" wires and make a twisted pair. At one end, connect either wire to either lug of pilot socket SA (S-2). Connect the other wire to the remaining lug on SA (S-2). At the other end of the twisted pair insert the wires into the hole CC on the large circuit board.
  - ( ) Prepare two 10" wires and make a twisted pair. At one end, insert the wires into the two holes marked DD on the small circuit board. Route the twisted pair between transformers P and Q as shown. At the other end, insert the wires into holes DD on the large circuit board.
  - ( ) Prepare two 13" wires and make a twisted pair. At one end, insert the wires into holes CC (adjacent to holes DD) on the large circuit board. At the other end, insert the wires into holes CC near tube V-5.
  - ( ) Using two prepared 7-1/4" wires, make another twisted pair. At one end, insert the wires into holes EE on the large circuit board. At the other end, insert the wires into holes EE on the small circuit board.
  - ( ) Prepare a 3-1/4" wire and insert one end into hole G on the small circuit board. Connect the other end to lug 3 on control R (NS).

- ( ) Prepare a 1-3/4" wire and connect between lug 3 of control R (S-2) and lug 3 of control S (S-1).
- ( ) Prepare a 3-1/2" wire and connect one end to lug 2 of control R (S-1). Insert the other end into the hole marked "BIN" on the small circuit board. Dress this wire close to the wire from lug 3.
- ( ) Prepare a 5-3/4" wire and connect one end to lug 2 of control S (S-1). Route wire as shown and insert the other end into the hole marked "A IN" on the small circuit board.
- ( ) Prepare a 7-1/2" wire and insert one end into the hole marked "A OUT" on the large circuit board. Connect the other end to lug 1 of control S (S-1). Route this wire as shown and dress it close to the circuit board.
- ( ) Prepare a 10" wire and insert one end into the hole marked "B OUT" on the large circuit board. Connect the other end to lug 1 of control R (S-1). Route as shown and dress close to the circuit board.
- ( ) Now turn the chassis over and solder all fourteen wire connections to the large circuit board. After soldering, trim off excess wire lengths.
- ( ) In the same manner, solder all seven wire connections on the small circuit board, then trim off excess.
- ( ) Now proceed to Figure 14 for preassembly of the input socket bracket.

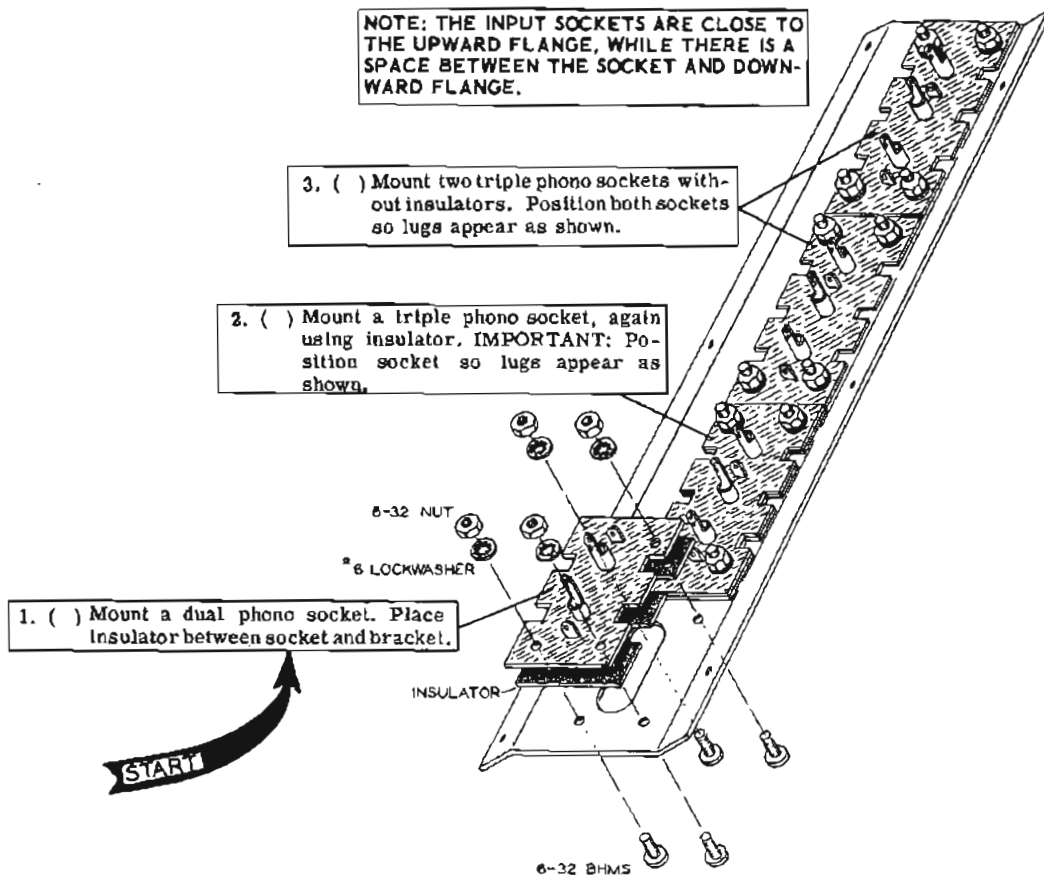

Figure 14

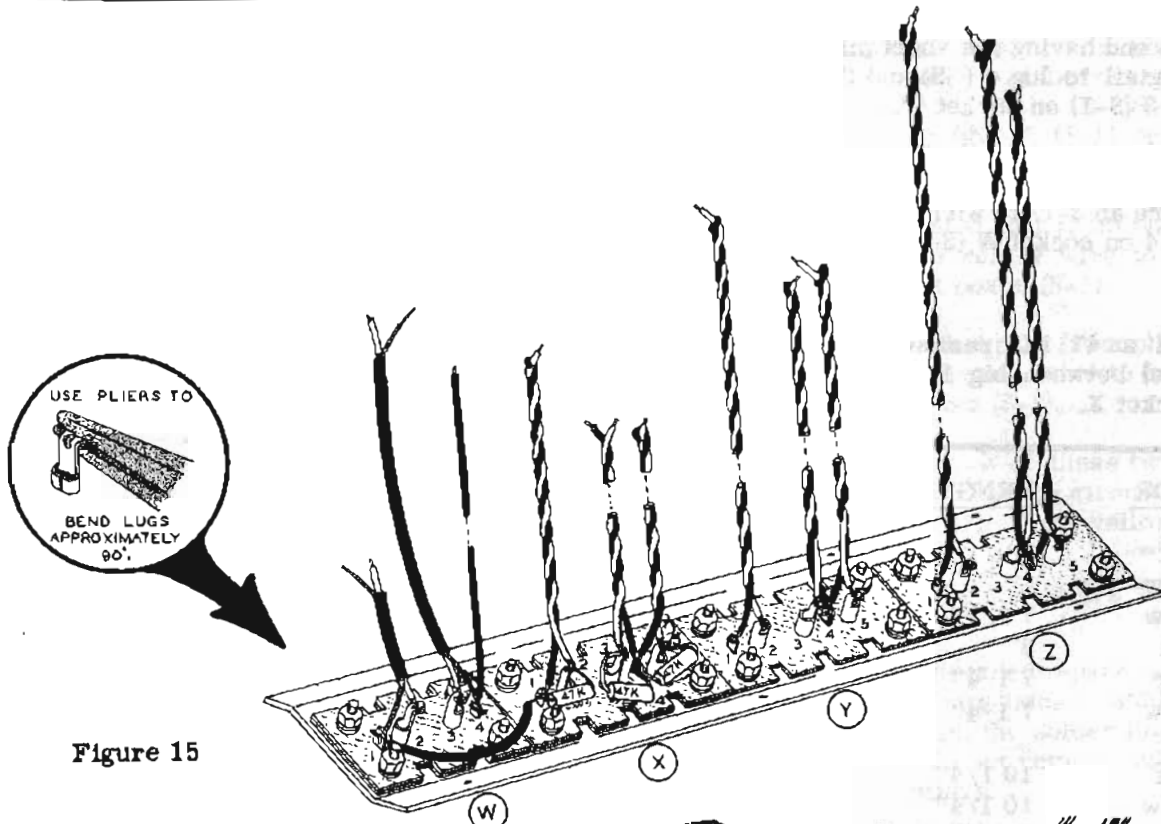

Figure 15



Detail 15A

Refer to Figure 15 for the following steps:

- ( ) Using pliers, bend all large lugs approximately 90 degrees, as shown in Figure 15 and in the inset of this figure.
- ( ) Prepare a 2-1/2" wire and connect between lug 1 on dual socket W (NS), and lug 1 on triple socket X (NS).
- ( ) Cut a 3" length of shielded cable and prepare it as shown in Detail 15B. The procedure is shown in Detail 15A.
- ( ) At the end having the short pigtail, connect the pigtail to lug 1 (S-2) and the inner conductor to lug 2 (S-1) on socket W.
- ( ) Cut a 6-1/2" length of shielded cable and prepare it as shown in Detail 15C.

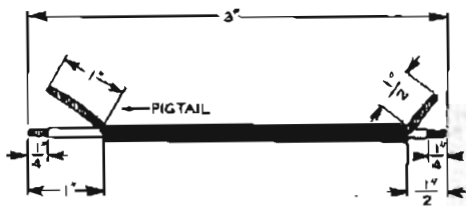

Detail 15B

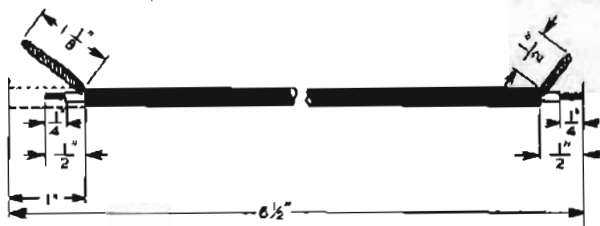

Detail 15C



- ( ) At the end having the short pigtail, connect the pigtail to lug 4 (NS) and the inner wire to lug 3 (S-1) on socket W.
- ( ) Prepare an 8-1/2" wire and connect one end to lug 4 on socket W (S-2).
- ( ) Install a 47 K $\Omega$  resistor (yellow-violet-orange) between lug 1 (NS) and lug 2 (NS) on socket X.
- ( ) Install another 47 K $\Omega$  resistor (yellow-violet-orange) between lug 3 (NS) and lug 4 (NS) on socket X.
- ( ) Install another 47 K $\Omega$  resistor (yellow-violet-orange) between lug 4 (NS) and lug 5 (NS) on socket X.

Following the step-by-step procedure in the table below, prepare and connect one end of a yellow or black wire to each phono socket lug. Then twist together the indicated pairs. Refer also to Figure 15.

|     | COLOR  | LENGTH  | STRIP     | CONNECT TO |     | Soldering Instructions |
|-----|--------|---------|-----------|------------|-----|------------------------|
|     |        |         |           | Socket     | Lug |                        |
| ( ) | Black  | 5"      | one end   | X          | 1   | (S-3) > twist          |
| ( ) | Yellow | 5"      | both ends | X          | 2   | (S-2) > twist          |
| ( ) | Yellow | 7 1/2"  | both ends | X          | 3   | (S-2) > twist          |
| ( ) | Black  | 8"      | both ends | X          | 4   | (NS) > twist           |
| ( ) | Black  | 7 1/4"  | one end   | X          | 4   | (S-4) > twist          |
| ( ) | Yellow | 7 1/4"  | both ends | X          | 5   | (S-2) > twist          |
| ( ) | Black  | 10 1/4" | one end   | Y          | 1   | (S-1) > twist          |
| ( ) | Yellow | 10 1/4" | both ends | Y          | 2   | (S-1) > twist          |
| ( ) | Yellow | 9 1/4"  | both ends | Y          | 3   | (S-1) > twist          |
| ( ) | Black  | 9 1/4"  | one end   | Y          | 4   | (NS) > twist           |
| ( ) | Black  | 8 1/2"  | one end   | Y          | 4   | (S-2) > twist          |
| ( ) | Yellow | 8 1/2"  | both ends | Y          | 5   | (S-1) > twist          |
| ( ) | Black  | 12 3/4" | one end   | Z          | 1   | (S-1) > twist          |
| ( ) | Yellow | 12 3/4" | both ends | Z          | 2   | (S-1) > twist          |
| ( ) | Yellow | 12      | both ends | Z          | 3   | (S-1) > twist          |
| ( ) | Black  | 12      | one end   | Z          | 4   | (NS) > twist           |
| ( ) | Black  | 11      | one end   | Z          | 4   | (S-2) > twist          |
| ( ) | Yellow | 11      | both ends | Z          | 5   | (S-1) > twist          |

- ( ) At the free end of each twisted pair not having insulation removed from the end of the black wire, double back the end of the black wire as shown in Figure 15.
- ( ) On the right-hand side of the chassis (power transformer side) remove three of the 3-48 screws, lockwashers, and nuts which fasten the chassis support bracket and large circuit board to the chassis.
- ( ) As shown in Detail 16A, mount the prepared input socket bracket over the flange of the chassis support bracket, and replace the three 3-48 screws, lockwashers, and nuts.

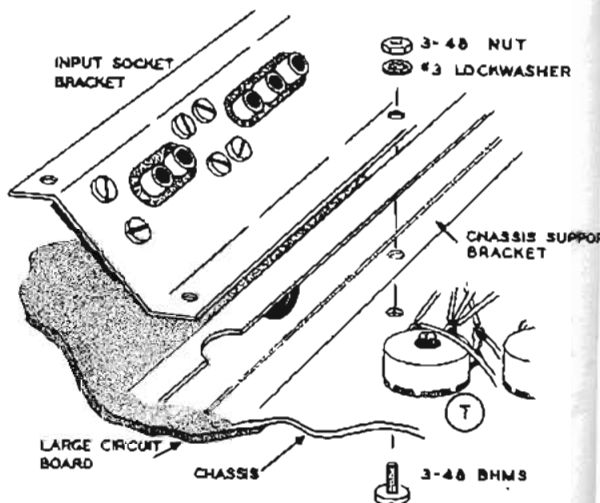

Detail 16A

Refer to Figure 16.

- ( ) Identify the single wire coming from lug 4 of dual phono socket W and connect the free end to solder lug L (S-3).
- ( ) At the free end of the longer shielded cable from phono socket W, slip a 7/8" length of sleeving over the pigtail and connect it to hole 20 on the large circuit board (S-2).
- ( ) Dress the pigtail which connects to lug 4 of dual socket W, so it will not touch lug 3 of this socket.
- ( ) Connect the inner conductor of the same cable to hole 3 (S-1).
- ( ) At the free end of the short shielded cable from phono socket W, slip a 7/8" length of sleeving over the pigtail and connect it to hole 25 on the large circuit board (S-1).
- ( ) Connect the inner conductor to hole 8 (S-1).
- ( ) Identify the twisted pair from phono socket X2. (See Figure 16 ) At the free end, connect the black wire to hole 21 (S-1) and the yellow wire to hole 2 (S-1) on the large circuit board.
- ( ) Identify the twisted pair from phono socket X1. Connect the yellow wire to hole 7 on the large circuit board (S-1).
- ( ) Identify the twisted pair from phono socket X3. Connect the yellow wire to hole 1 on the large circuit board (S-1).

NOTE: The black wires of these twisted pairs are not to be connected at the circuit board end. They serve only to shield the yellow wires, to minimize hum pickup.

The six remaining twisted pairs will be connected later.

- ( ) Install .698" threaded spacers (#255-47) on the three transformer studs and the screw stud holding the solder lug, as shown in Figure 16. Do not remove nuts. Tighten spacers with pliers.

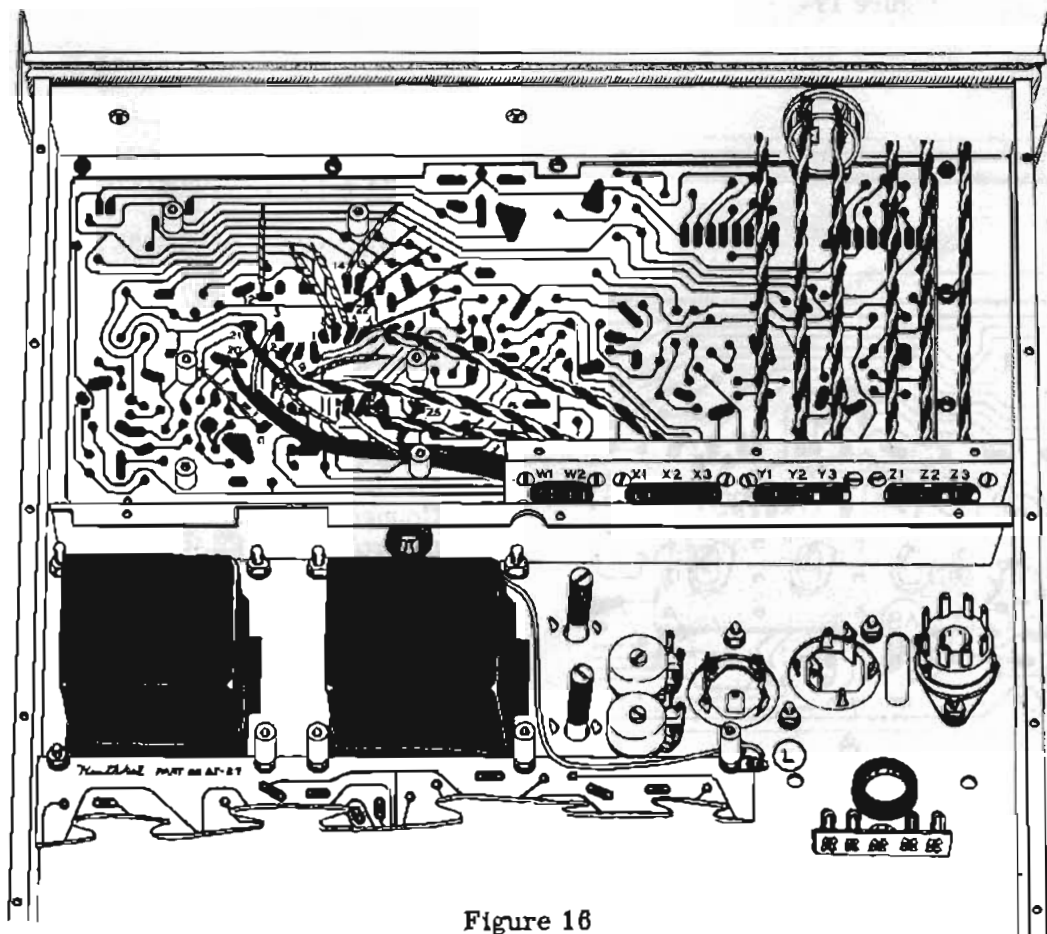

Figure 16

## INSTALLATION OF INPUT LEVEL CONTROLS

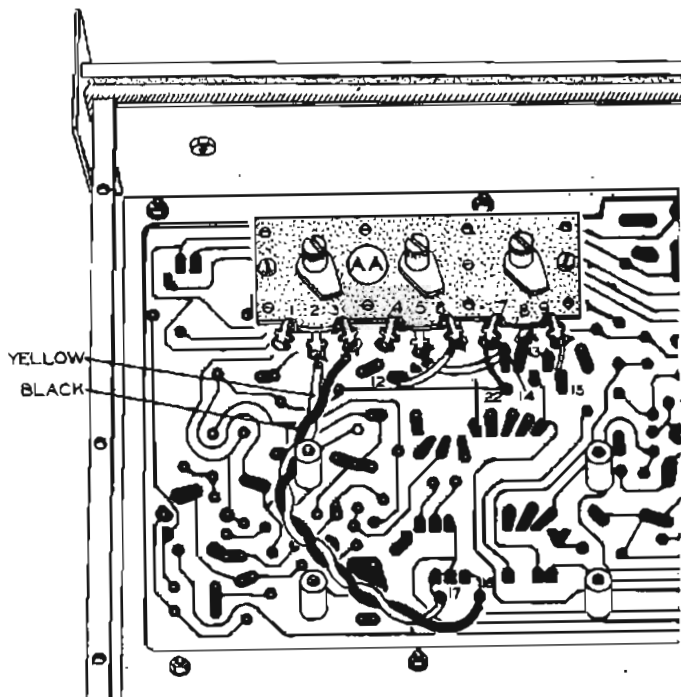

Figure 17

- ( ) As shown in Figure 17, install a triple 250 KΩ control (#13-3) at AA, on the indicated pair of phenolic spacers. Use 3-48 screws.
- ( ) Identify the twisted pair coming from circuit board holes 16 and 17. Connect the yellow wire to lug 2 (S-1) and the black wire to lug 3 (S-1) of triple control AA.
- ( ) Connect the wire from hole 14 to lug 5 of control AA (S-1).
- ( ) Connect the wire from hole 12 to lug 6 (S-1) of control AA.
- ( ) Connect the wire from hole 22 to lug 7 (NS) of control AA.
- ( ) Connect the wire from hole 13 to lug 8 of control AA (S-1).
- ( ) Connect the wire from hole 15 to lug 9 of control AA (S-1).

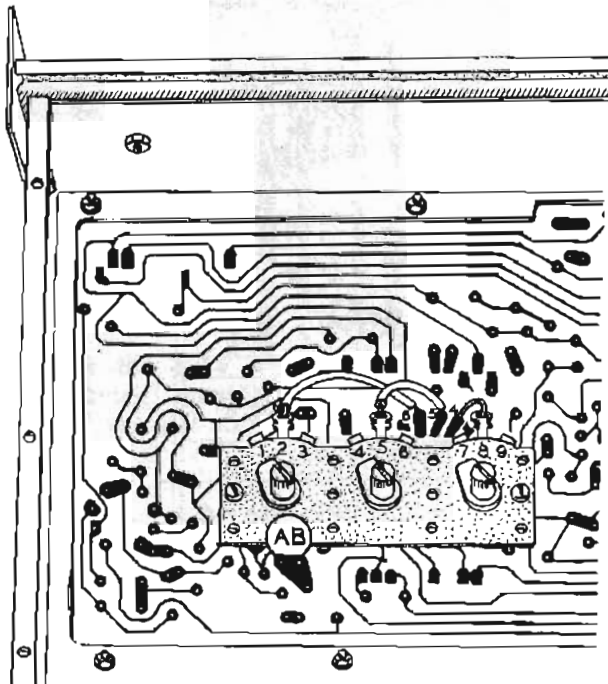

Figure 18

- ( ) Position the short wires from holes 11, 10, and 9 close to the circuit board, and pointing to the rear of the chassis.
- ( ) Install another triple 250 KΩ control AB. See Figure 18.
- ( ) Connect the wire from hole 6 to lug 2 of control AB (S-1).
- ( ) Connect the wire from hole 5 to lug 5 of control AB (S-1).
- ( ) Connect the wire from hole 4 to lug 8 of control AB (S-1).
- ( ) Slip a 5/8" length of sleeving over the wire connected to hole 11.

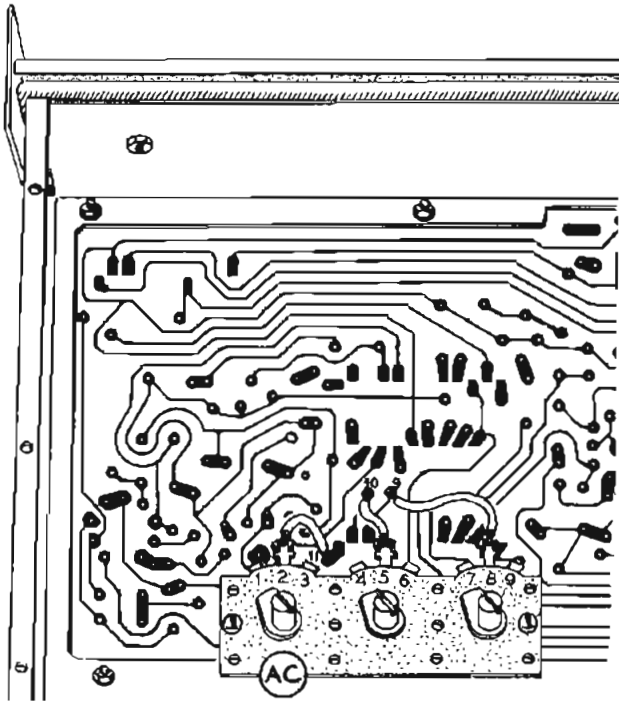

Figure 19

- ( ) Install the remaining triple 250 K $\Omega$  control AC. See Figure 19.
- ( ) Connect the wire from hole 11 to lug 2 of triple control AC (S-1).
- ( ) Connect the wire from hole 10 to lug 5 of control AC (S-1).
- ( ) Connect the wire from hole 9 to lug 8 of control AC (S-1).

Refer to Figure 20.

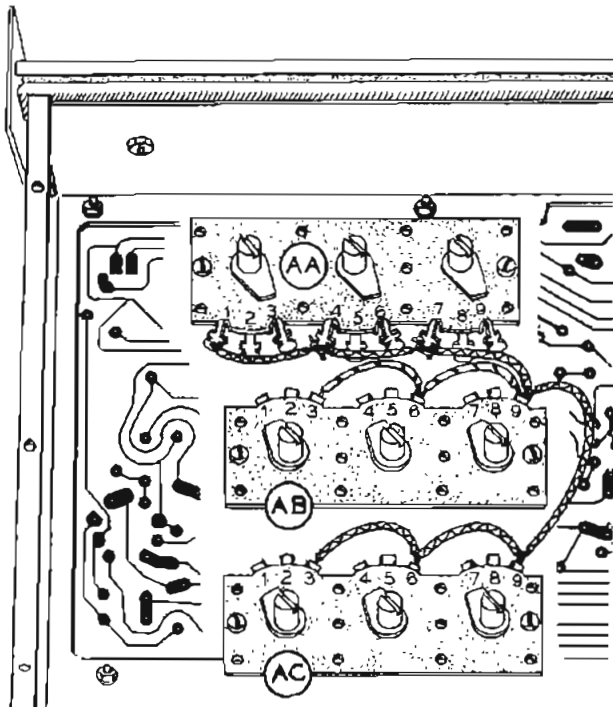

Figure 20

- ( ) Prepare a 1-3/4" wire and connect between lug 1 (S-1) and lug 4 (NS) on triple control AA.
- ( ) Prepare another 1-3/4" wire and connect between lug 4 (S-2) and lug 7 (NS) on triple control AA.
- ( ) Prepare another 1-3/4" wire and connect between lug 3 (S-1) and lug 6 (NS) on triple control AB.
- ( ) Prepare another 1-3/4" wire and connect between lug 6 (S-2) and lug 9 (NS) on triple control AB.
- ( ) Prepare another 1-3/4" wire and connect between lug 3 (S-1) and lug 6 (NS) on triple control AC.
- ( ) Prepare another 1-3/4" wire and connect between lug 6 (S-2) and lug 9 (NS) on triple control AC.
- ( ) Prepare another 1-3/4" wire and connect between lug 7 on triple control AA (S-3) and lug 9 on triple control AB (NS).
- ( ) Prepare a 2-1/4" wire and connect between lug 9 on control AB (S-3) and lug 9 on control AC (S-2).



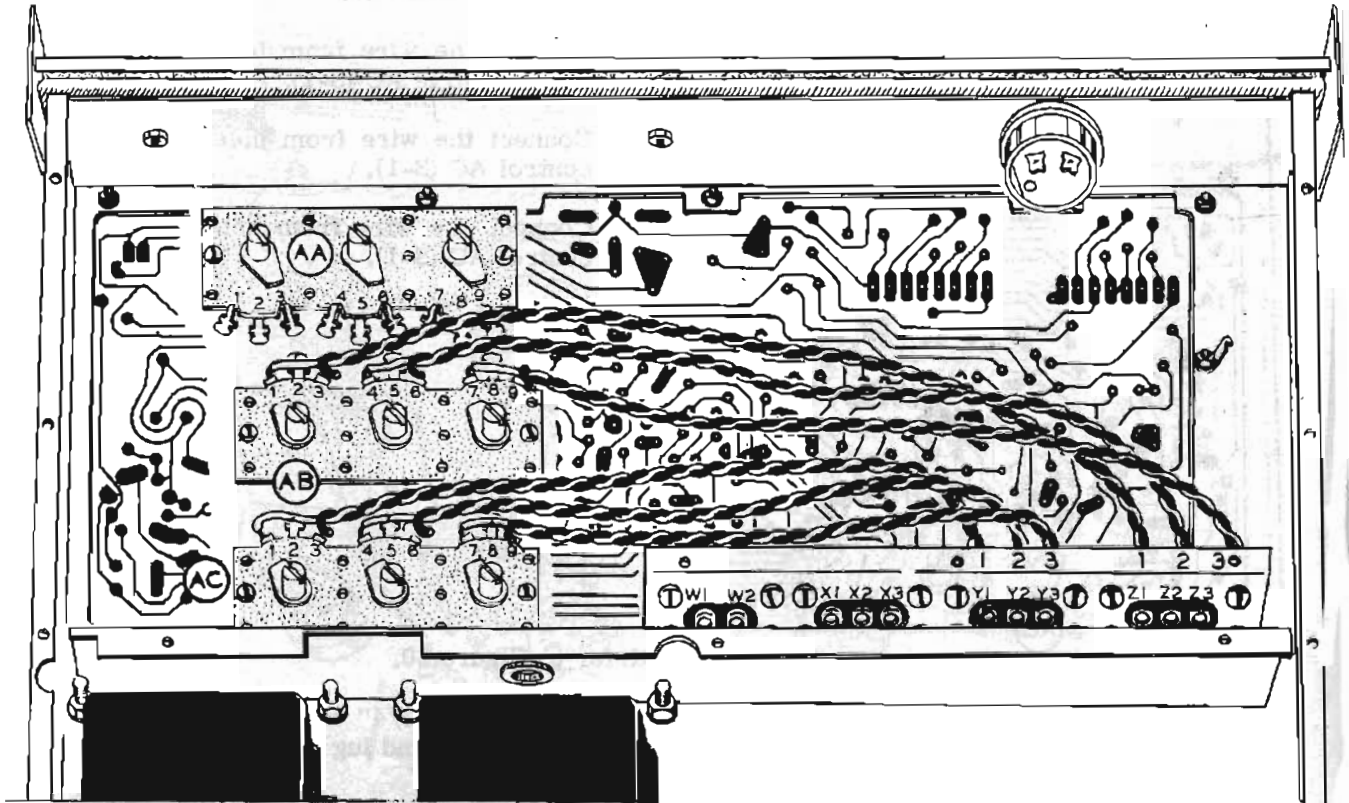

Figure 21

Refer to Figure 21.

- ( ) Identify the twisted pair coming from phono socket Y3. At the free end connect the yellow wire to lug 7 on control AC (S-1).
- ( ) Identify the twisted pair coming from phono socket Y2. At the free end connect the yellow wire to lug 4 on control AC (S-1).
- ( ) Identify the twisted pair coming from phono socket Y1. At the free end connect the yellow wire to lug 1 on control AC (S-1).
- ( ) On triple phono socket Z, identify the twisted pair coming from socket 3, and at the free end connect the yellow wire to lug 7 on control AB (S-1).
- ( ) Identify the twisted pair coming from phono socket Z2 and at the free end connect the yellow wire to lug 4 on control AB (S-1).
- ( ) At the free end of the remaining twisted pair, coming from phono socket Z1, connect the yellow wire to lug 1 on control AB (S-1).

This completes the wiring of your Model AA-100 Amplifier. At this time it would be advisable to carefully examine all connections for proper soldering, and to assure that there are no short circuits due to excess solder, or to untrimmed wire ends protruding from soldered connections. Finally, shake out all loose bits of solder and wire that may have accumulated.

**NOTE:** If you have an appropriate DC voltmeter, it would be well to check main supply voltages in the amplifier, when applying power for the first time. If it is desired to do this, do not install the bottom cover yet.

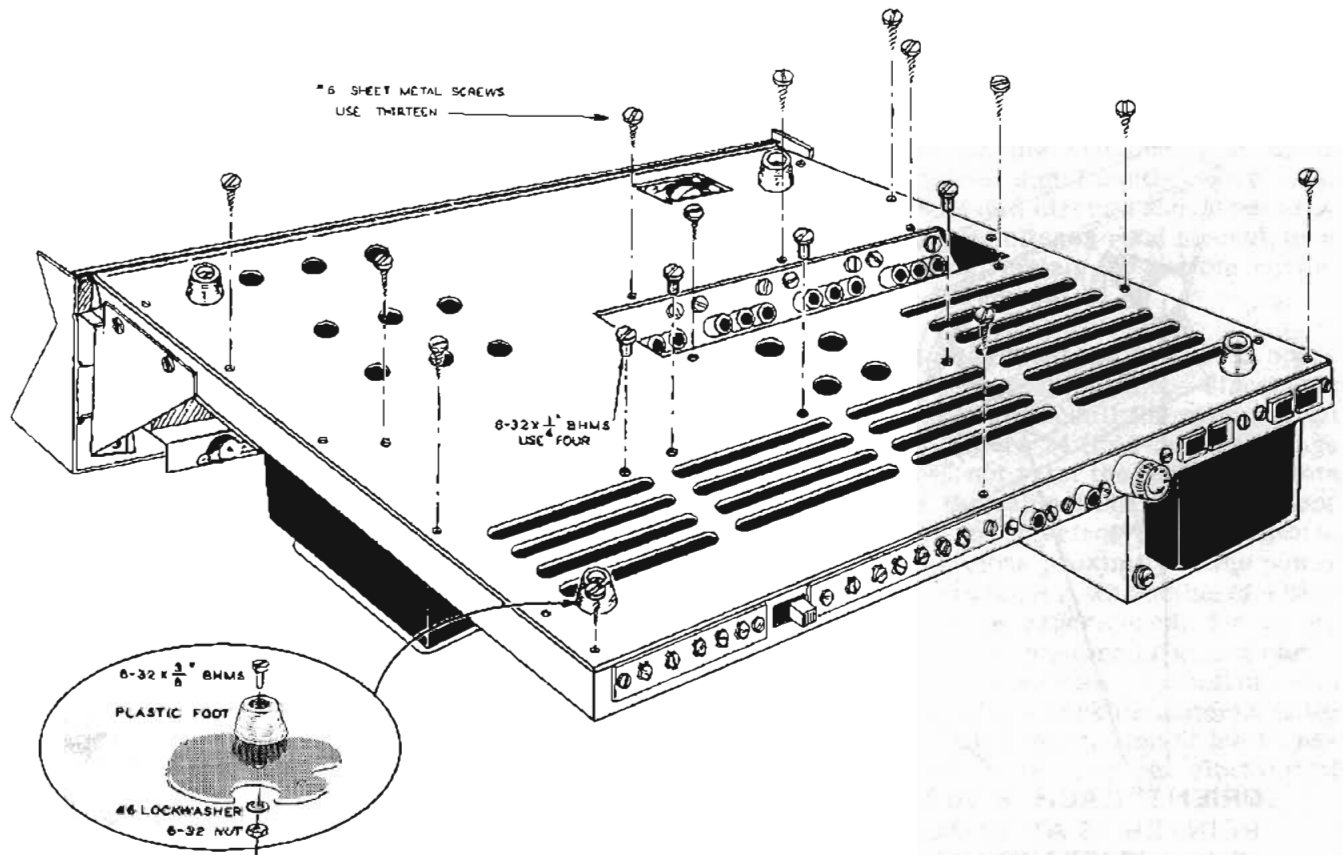

Figure 22

- ( ) As shown in Figure 22, install the four plastic feet on the chassis bottom cover. Then install the bottom cover, using thirteen #6 sheet metal screws, and four 8-32 x 1/4" BHMS. Note: Use only the screw holes indicated; the remaining six holes will be used when the cabinet shell is installed.
- ( ) Refer to Figure 23 and install all ten knobs.
- ( ) Install the nameplate as follows:
  - A. The surface to which the nameplate is to be applied should be clean and dry.
  - B. Remove the paper backing from the nameplate. A pin or pointed knife blade can be used to start removal of the paper backing and to remove any paper that might remain in the back of the nameplate. Do not touch the adhesive back with your fingers.

- C. Apply the nameplate with even finger pressure; even pressure is the key to good adherence.

**IMPORTANT:** In the following step, use care when inserting the four 7591 tubes. If these tubes are forced into their sockets with excessive pressure, the circuit board may crack.

- ( ) Insert all tubes in their proper sockets on the circuit boards. The tube type number appears near each tube socket. Do not insert the GZ-34/5AR4 rectifier tube yet.
- ( ) Install tube shields over V1 and V2 on the large circuit board. Be sure the grounding clip on each socket slips under the shield.

Your amplifier is now ready for initial test.

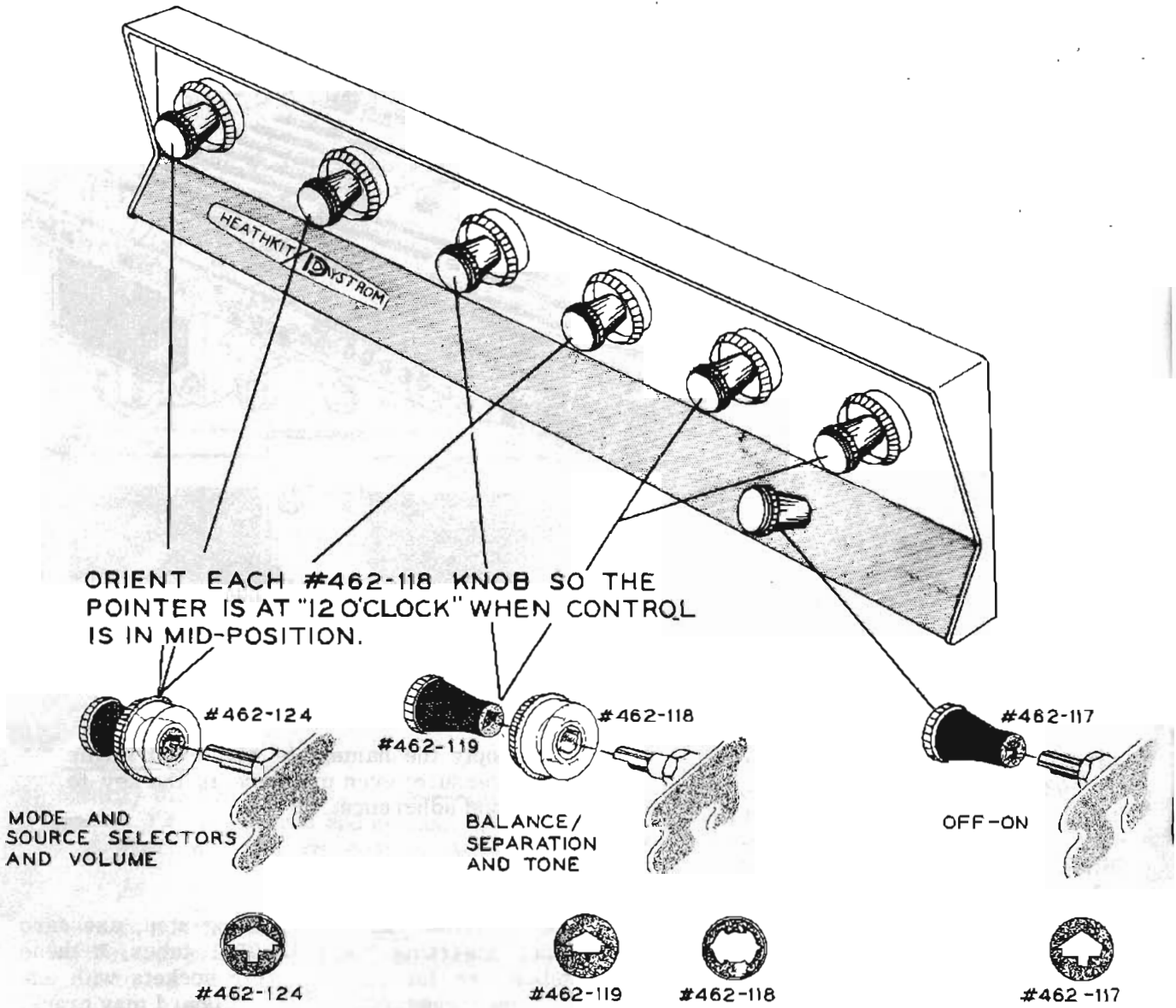

Figure 23

INITIAL TEST

In order to insure against possible serious damage which could conceivably result from a construction fault, it is recommended that the following procedure be observed in applying power to your AA-100 for the first time.

- ( ) Turn the front panel LEVEL control to its maximum counterclockwise position. The POWER switch should be in the OFF position. Plug the line cord into electrical outlet, 105-125 volts, 50/60 cycle AC only.
- ( ) Turn the POWER switch ON; the pilot lights should light. After about half a minute, the tube filaments (heaters) should be lit, and exhibit a dull red or orange glow. It is difficult to see the filaments of the EF-86 tubes; however, these tubes should become noticeably warm after a few minutes.

**CAUTION:** Do not touch any exposed leads on the circuit boards while power is on.

- ( ) Now turn the power OFF, insert the GZ-34/5AR4 tube in the octal socket (near the power transformer) and turn the power ON again. The 7591 tubes should exhibit no additional red glow than was observed prior to installing the GZ-34. The latter's filament should glow, but its gray metal plates should not turn red. Neither should the plates of the 7591's. If they do, it is a sign of excessive current drain, probably due to a short circuit; in that event, turn power OFF immediately and do not reapply power until the trouble is found and corrected. Refer to the IN CASE OF DIFFICULTY section on Page 43.

**NOTE:** A blue glow (fluorescence) around the plate structure of the 7591's is NORMAL and should not be interpreted as a sign of trouble.

- ( ) This would be a good time to check at least the main supply voltages in the amplifier. All normal DC voltages appear on the schematic. The main supply voltages are considered to be (1) The 7591 plate supply voltage - pin 8 of V-13; (2) The 7591 screen supply voltage - present at the junction of R-101 and R-102 (also hole 42 on small circuit board); (3) The bias supply voltage -

present at the junction of R-105 and R-106 (also hole 40 on small circuit board). The latter voltage is NEGATIVE with respect to chassis. Note the conditions of measurement stated on the schematic. If these voltages deviate significantly more than 10%, the associated circuits should be carefully checked. If voltages read normal, turn power OFF and install the bottom cover, as shown in Figure 22.

- ( ) If you are satisfied that the AA-100 is operating normally at this time, disconnect electrical power and install the cabinet shell as shown in Figure 24 (fold-out from Page 34). Be careful not to let the ventilating slots in the top of the cabinet shell snag the tops of the can-type electrolytic capacitors.

**NOTE:** Due to the close proximity of the power transformer to the top cover, an audible mechanical vibration may be experienced, due to the magnetic field of the transformer acting on the cover. To eliminate this, wedge a small piece of foam rubber or resilient packing material (used in packing your kit) between the top of the transformer and the cover to damp out vibration of the cover.

LOUDSPEAKER CONNECTIONS

- ( ) Connect the left speaker to the LEFT SPKR terminals. Depending upon the impedance of this speaker (4  $\Omega$ , 8  $\Omega$  or 16  $\Omega$ ), connect wire with spade lug to the appropriate screw terminal on the LEFT SPKR IMPEDANCE terminal strip.
- ( ) Connect one wire from the right speaker to the C (Common) terminal under the RIGHT SPKR terminals. Connect the other wire to the appropriate terminal (4  $\Omega$ , 8  $\Omega$  or 16  $\Omega$ ), depending upon the speaker impedance.

**NOTE:** The common (C) marked speaker terminals are not connected directly to chassis ground. Any grounding of these terminals will result in distortion and loss of power output. When measuring or installing the AA-100, the speaker leads must be ungrounded, and no connection should be made between the LEFT and RIGHT channel outputs.



### INITIAL HUM BALANCE ADJUSTMENT

( ) Set all controls as follows:

MODE SELECTOR switch - STEREO NORM.  
SOURCE SELECTOR switch - STEREO  
NORM. PHONO  
BALANCE control - 12 o'clock position  
SEPARATION control - maximum counter-  
clockwise (at normal)  
VOLUME control - maximum counterclock-  
wise

LEFT CHANNEL TONE } 12 o'clock  
RIGHT CHANNEL TONE } (flat) positions

( ) Under the chassis, set all nine INPUT LEVEL controls and the two INPUT LEVELS TO POWER AMPS controls to their maximum clockwise positions.

( ) Before making any input connections, turn POWER switch ON and wait approximately one minute for the tubes to warm up. Now advance the VOLUME control until a hum is heard in both speakers. Carefully adjust the RIGHT CHAN HUM BALANCE control until the hum level is minimum, as heard from the RIGHT speaker. Now adjust the LEFT CHAN HUM BALANCE control for minimum hum, as heard from the LEFT speaker. As the hum is progressively reduced by the HUM BALANCE controls, it will probably be necessary to turn up the VOLUME control in order to better detect the condition of minimum hum, which is quite critical. The HUM BALANCE controls should be readjusted later, after the input sources have been connected to the AA-100. The minimum hum will also be much lower when the inputs are connected.

### INSTALLATION

The Model AA-100 is primarily intended to set in an "open" location, such as a table top or shelf. Its decorative cabinet shell was designed for this type of installation. The unit may be panel mounted, if desired, by removing the feet and the cabinet shell. When mounted in this way, the cutout is completely covered by the front panel, resulting in a neat installation. Vertical mounting (panel horizontal) is not recommended.

VENTILATION is important for long component life in any piece of electronic equipment, due to the unavoidable generation of heat within the equipment. In the Model AA-100, ventilation is obtained by the open back and the slots in the cabinet shell and bottom cover. When operated on a shelf, the back of the cabinet should be at least an inch from the wall; also, a clearance of at least 2" above the top of the cabinet should be provided. If these precautions are followed, adequate air circulation will be promoted and the unit will run relatively cool.

Adequate ventilation will ordinarily be no problem if the unit is installed in an open-back cabinet, provided there is a small amount of clearance above the unit for hot air to escape.

**IMPORTANT: BECAUSE OF THE EXTREME SENSITIVITY AND HIGH POWER OUTPUT OF THE AA-100, IT IS IMPERATIVE THAT THE FOLLOWING PRECAUTION BE OBSERVED:**

**NEVER UNDER ANY CIRCUMSTANCES CONNECT OR DISCONNECT ANY INPUTS WHILE POWER IS ON, WITHOUT FIRST TURNING THE VOLUME CONTROL FULLY COUNTERCLOCKWISE. FAILURE TO OBSERVE THIS PRECAUTION MAY DAMAGE THE SPEAKERS OR OUTPUT TRANSFORMERS, NECESSITATING COSTLY REPAIR OR REPLACEMENT.**

#### INPUT CONNECTIONS

Most signal sources terminate in a standard RETMA phono plug which fits the input sockets of your AA-100. Eight plugs of this type, along with a length of shielded cable, are furnished for the purpose of making up input cables for connection to the AA-100. See Figure 25.

If you are in doubt about the correct input connections for the various types of signal sources, the following information should prove helpful.

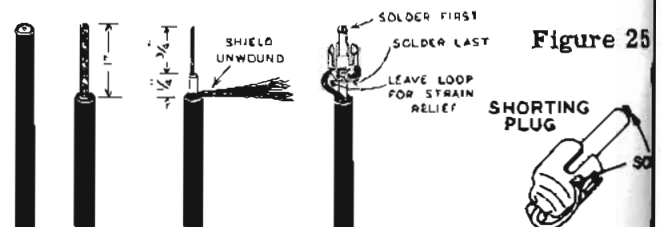

**NOTE:** The shielding of the input cable should not touch the chassis of the AA-100 at any point. Grounding to the chassis at this point could create excessive hum.

|   |  |
|---|--|
| MONO PHONO: . . . . .   | For monophonic magnetic or variable reluctance phono pickups.  |
| STEREO PHONO: . . . . .   | For stereophonic magnetic or variable reluctance phono pickups.  |
| TAPE HEAD: . . . . .  | For direct connection to playback heads on tape decks.   |
| TUNER, AUX 1, or 2: . . . . .   | For AM or FM tuners, complete tape recorders (having their own playback preamplification and equalization), crystal or ceramic phono pickups,* capacity (FM) phono pickups with required oscillator, and compensated phono pickup preamplifiers (all types).   |
| OUTPUT TO TAPE RECORDER INPUT: . . . . .  | For feeding signal to an external tape recorder to record from tuner, records, etc., either in stereo or monophonically. The "high level" input of the tape recorder should be used - this may be designated "high level," "radio," or "line." The input impedance should be at least 150,000 $\Omega$ . |
| *Crystal or ceramic pickups may also be connected to PHONO provided they are appropriately loaded (usually with a relatively low resistance) to make them "velocity responsive." Most manufacturers of these types of pickups furnish recommended termination circuits, which should be followed regardless of which input is used. |  |

**INPUT LEVEL CONTROLS**

After making all input connections, the INPUT LEVEL controls should be adjusted for approximately equal volume levels as the SOURCE SELECTOR switch is turned from one input to another.

No level controls are provided for the TAPE HEAD inputs. This is because generally the signal from the tape head will be lower in level than that from the magnetic phono pickup. Therefore, the PHONO level controls should be adjusted so as to bring the PHONO levels down to match that of the tape head. The level controls for TUNER, AUX 1 and 2 should be adjusted to the same level. If the TAPE HEAD inputs are not used, hum may be experienced when switching through the TAPE HEAD mode of the selector switch. To eliminate this hum, construct shorting plugs as shown in Figure 25, and insert them into the TAPE HEAD inputs.

Because of the very high sensitivity (1.5 millivolts) of the PHONO inputs, audible distortion may be experienced when using higher output cartridges if the PHONO INPUT LEVEL controls are operated at their maximum settings. For this reason, the following maximum settings for these controls should be observed.

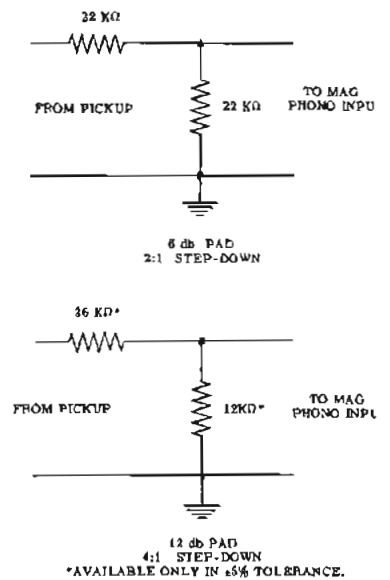

Figure 26

For cartridge output of less than 5 mv, the control may, generally, be left in the maximum clockwise position.

For cartridge output of 5 mv, turn control counterclockwise one-fifth of its rotational range below maximum clockwise position.

For cartridge output of 10 mv, turn control counterclockwise one-third of its rotational range below maximum clockwise position.

For cartridge output of 20 mv, turn control counterclockwise one-half of its rotational range below maximum clockwise position.

(These settings make allowance for high velocity recorded peaks.)

For magnetic pickups of greater output than 20 millivolts (at stylus velocity of 5 cm/sec.), an L-pad should be installed at the input socket to prevent overloading the preamplifier stages, and at the same time present the proper load to the pickup. Two L-pads are illustrated in Figure 26. They may be easily installed at the input sockets. The resistors are standard 1/2 watt values which may be secured at any radio or electronic supply store. Be sure to remove the 47 KΩ resistor already installed on each phono input socket.

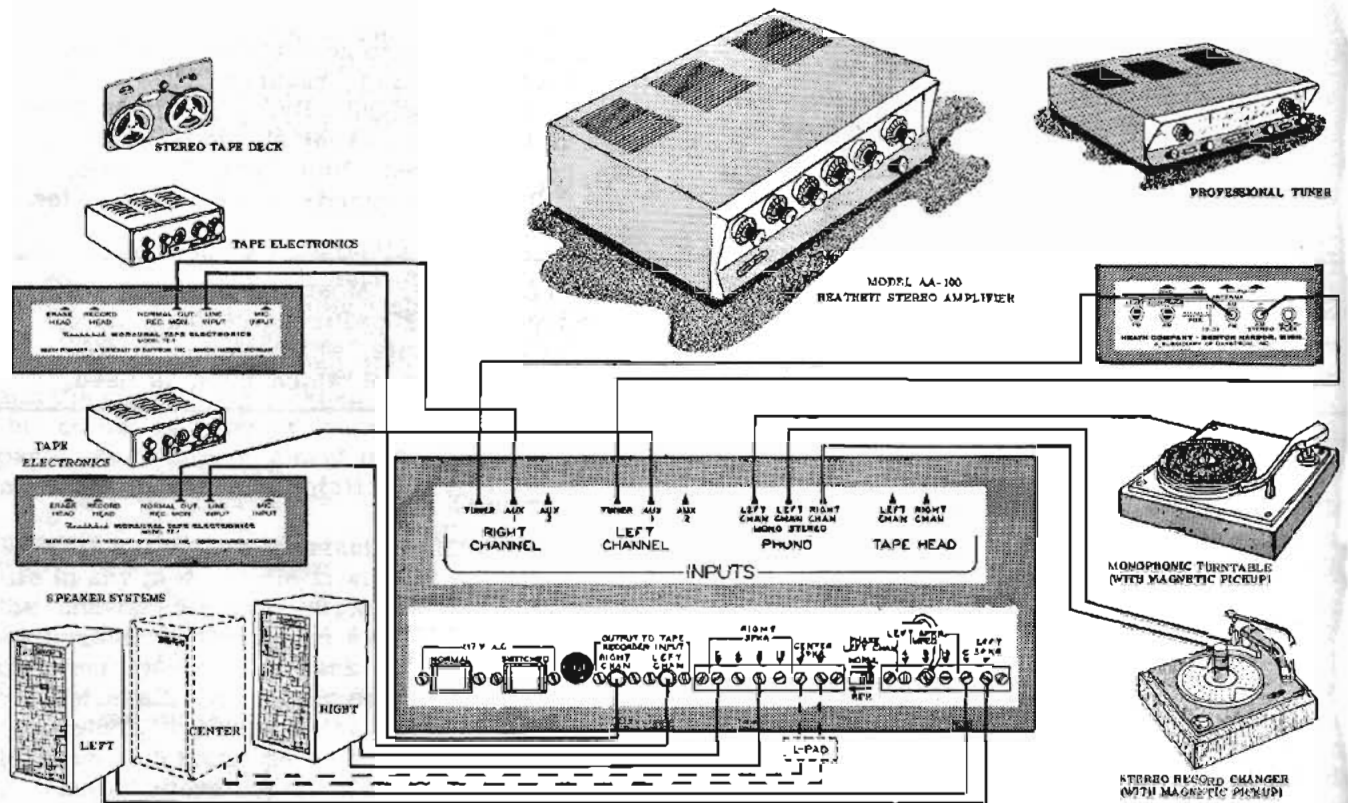

Figure 27

In addition to the INPUT LEVEL controls mentioned above, each power amplifier in the AA-100 has an INPUT LEVEL control. The normal positions of these controls are full clockwise. However, in case of a higher efficiency speaker in one channel than in the other, the gain of the first channel may be permanently reduced by means of its INPUT LEVEL control.

**ACCESSORY POWER**

Two outlets on the rear chassis apron may be used to supply power to accessory equipment, such as record changer, tape deck, or tuner. The SWITCHED outlet is controlled by the POWER switch on the AA-100. The NORMAL outlet supplies power as long as the AA-100 is

plugged into the power source. This outlet is intended for devices such as record changers or tape decks, which may be subjected to damage if power is removed without shutting off the mechanism.

Figure 27 shows connections of a complete stereo system using the AA-100.

### SPEAKER PLACEMENT

Generally, for stereo listening, the two loudspeakers should be spaced six to eight feet apart. They should be placed along a wall, either facing straight ahead or "firing in" toward each other's axis at a right angle to the wall. The optimum positions can best be determined by experiment. A great deal depends upon the size and acoustics of the room and upon the high frequency dispersion characteristics of the speakers. Identical speakers or speaker systems are recommended.

The correct speaker spacing depends to some extent upon the listener's position and distance from the speakers. In other words, if the listening position is restricted to one that is relatively close to the speakers, some improvement could

probably be obtained by moving the speakers closer together.

Remember that in stereophonic reproduction we are striving to recreate not only the sounds of "right" and "left" origin but also those near the center, as accurately in position as possible. By all means, experiment with speaker and listening positions sufficiently to arrive at the best set of conditions for your particular installation.

### ELIMINATING "HOLE-IN-THE MIDDLE" EFFECT

This effect is not uncommon in two-channel stereo reproduction. It may be due to microphone placement and/or acoustics at the recording (or broadcast) location, or it may be due to excessive speaker separation, or an unfavorable listening position.

Either of two methods may be used to eliminate or minimize the hole-in-the-middle effect: (1) Use of the SEPARATION control; (2) Use of a center speaker. Both of these methods are discussed under OPERATION.

## OPERATION

Assuming that all input and output connections have been made and that all LEVEL controls have been adjusted, any stereo source connected to corresponding inputs of the Left and Right Channels, and selected by the SOURCE SELECTOR switch, should be heard in the speakers. The MODE SELECTOR switch should be in the STEREO NORM position. The listening levels of both channels may be adjusted simultaneously by means of the VOLUME control. When the TONE control knobs are in the vertical (12 o'clock) positions, the overall response is flat. Turning either the bass or the treble control of either channel clockwise boosts bass or treble of that channel; counterclockwise rotation cuts bass or treble.

Turning the BALANCE control either way from the 12 o'clock position increases the level of one channel, and simultaneously decreases the level of the other channel. As the markings on the front panel window indicate, turning the control toward "L" shifts the sound toward the left; turning it toward "R" shifts the sound to the right. This control should be used to keep the

two channels balanced, despite any unbalance in the program material.

The normal position of the SEPARATION control (full counterclockwise) is designated on the front panel. This is the position of normally high channel separation, and maximum stereo effectiveness. Turning the control clockwise gradually mixes both channels together until, in the full clockwise position, both speakers are carrying both channels, completely mixed, and the stereo source has been made completely monophonic.

The principal purpose of the SEPARATION control is to permit whatever degree of mixing is necessary to eliminate the "hole-in-the-middle" which is present in some stereo material. This control will be found extremely effective in such cases.

The following additional use of the SEPARATION control should be noted: Any normally phased stereo phono cartridge will play monophonic records successfully if its two "hot" terminals



are tied together. Since both channels are tied together when the SEPARATION control is fully clockwise, monophonic records may be played in this way with a stereo pickup.

In the Model AA-100, a pair of output terminals for a center speaker is provided. This may be used (as an alternative to the SEPARATION control) to fill the "hole-in-the-middle." The signal for the center speaker, as derived within the AA-100, is proportional to the instantaneous sum of the left and right (A and B) signals. Therefore, it is a maximum when the A and B signals are in-phase, and zero if A and B signals happen to be completely out-of-phase.

Because of these relationships, behavior of the center speaker will be correct to give center fill without sacrificing stereo effectiveness.

An adjustable L-pad is necessary to permit adjustment of volume level of the center speaker. For optimum center fill, it will be found that only a very low level is desired for the center speaker. For this reason, there is nothing critical as to the type of speaker used; almost any speaker will suffice. The speaker voice coil impedance may be from 4 to 16 ohms. Figure 28 shows proper L-pad connection in the center speaker circuit.

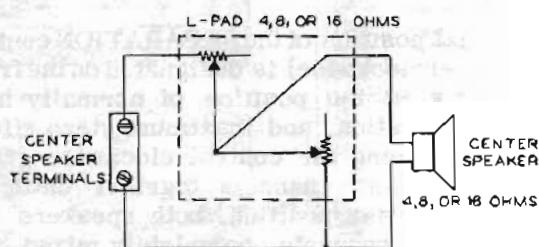

Figure 28

When the MODE SELECTOR switch is in the STEREO NORM position, the external connections should be such that the Left Channel feeds the LEFT\* speaker and the Right Channel the RIGHT speaker.

\*Defined as the listener's left when facing the speakers.

Turning the MODE SELECTOR switch to the STEREO REV position reverses the two channels, with respect to the speakers. This switch position serves as a convenient corrective for stereo material which might be reversed.

For example, many radio stations today broadcast stereo by means of simultaneous FM and AM transmission, but there is no set standard as to which is left and which is right. By means of the STEREO NORM and STEREO REV positions, the channels may be instantly reversed, if the situation demands. It is only necessary that the FM source be connected to one of the high-level inputs on one channel; for example, TUNER, Left Channel, and the AM source to the corresponding input of the other channel (in this example, TUNER, Right Channel).

Remember that when the MODE SELECTOR switch is in the STEREO NORM position, all monophonic sources connected to Left Channel inputs will be heard only in the LEFT speaker, and all monophonic sources connected to Right Channel inputs will be heard only in the RIGHT speaker. (Of course in the STEREO REV position, the reverse is true.) When the MODE SELECTOR switch is in the MONO LEFT position, all monophonic sources connect to MONO RIGHT Channel inputs will be heard in both speakers. Similarly, when the switch is in the MONO RIGHT position, all monophonic sources connected to Right Channel inputs will be heard in both speakers. For example, MONO PHONO which connects to the input of the Left Channel preamplifier only, will be heard in both speakers only when the MODE SELECTOR switch is in the MONO LEFT position.

Monophonic sources, when reproduced in this way over both speakers, may be given a "pseudo-stereo" effect by adjusting the TONE controls so that one channel contains mostly high frequencies and the other channel contains mostly low frequencies. This will give an added dimension to orchestral music, since some instruments will seem to be located on one side, and others on the other. The overall effect bears some resemblance to true stereophonic sound, hence the term "pseudo-stereo."

**SPEAKER PHASING:** The two speakers should be connected so that they are "in phase" when the LEFT PHASE switch (located on the rear

chassis apron) is in the NORM position. "In phase" means that both speaker cones move in the same direction at the same time. (If two-way speaker systems are used, phasing refers to the low-frequency woofers.)

Speaker phasing can be easily determined in the following manner: Disconnect one of the low level inputs and set the SOURCE SELECTOR switch to the corresponding input. Turn the MODE SELECTOR switch to MONO LEFT or MONO RIGHT, whichever channel the input was removed from. Advance the VOLUME control until a hum is heard in the speakers. (Turn the appropriate HUM BALANCE control, if necessary, to create a hum level.) Place the speakers

side by side. Find the position of the LEFT PHASE switch which gives the loudest hum when you stand directly in front of the speakers. If this is the NORM position, the speakers are in phase when the switch is in NORM. If it is the REV position, reverse the wires to one of the speakers; then they will be in phase when the switch is in NORM. If the HUM BALANCE controls were turned, readjust them for minimum hum again.

The switch should normally be left in the NORM position. If you encounter stereo program material which seems to be out-of-phase, you can correct it by throwing the switch to REV.

### IN CASE OF DIFFICULTY

Recheck the wiring. Trace each lead in colored pencil on the pictorial diagrams as it is checked in the amplifier. Most cases of difficulty result from wrong connections. Often having a friend check the wiring will reveal a mistake consistently overlooked.

Compare the tube socket voltages with those shown in the schematic diagram. Readings within 20% of those shown may be considered as normal. If a discrepancy is noted, check the associated circuits carefully. Any component in those circuits should be suspected until proven satisfactory.

In the case of any performance deficiency in the AA-100, it should first be noted whether the trouble is in the Left Channel, Right Channel, or both. This includes hum, noise, weak signal, distortion, or loss of signal.

Any difficulty that is common to both channels is most likely caused by a defect in the common power supply. If the difficulty is confined to one channel, tubes may be substituted from the other channel; in this way, a defective tube may be quickly isolated.

In the event that one of the circuit boards of your AA-100 has been ruined through accidental use of acid or paste fluxes, or for any other reason, a convenient repair kit is available for each of the two boards. Each kit consists of a new circuit board, new tube sockets, and all board-mounted resistors and capacitors. The #63-247 and #63-248 switches, and #212-6, #12-27, and #12-28 controls are not included

since these items can probably be successfully removed from the damaged board. This can best be accomplished by cutting up the board directly underneath the switches and controls, using diagonal cutters. Then unsolder and remove the circuit board fragments from the individual switch or control prongs. Should this effort prove unsuccessful, however, new switches and controls can be ordered as required.

The repair kits may be ordered from the following information:

- |                   |   |
|-------------------|---|
| Kit No. AAR-100-1 | Preamplifier circuit board repair kit.    |
| Kit No. AAR-20    | Power amplifier circuit board repair kit. |

### SPECIFIC TROUBLES

**HUM:** Hum in a hi-fi amplifier is usually caused by excessive heater to cathode leakage in one of the tubes, a poor ground connection, a faulty filter capacitor, or, in many cases, improperly placed leads. A faulty electrolytic filter capacitor that is responsible for hum will allow an excessive amount of AC ripple to be present in the DC B+ voltage. These capacitors can be checked either by direct substitution or with a good capacitor tester.

If hum is a problem only when using the low level inputs (PHONO and TAPE HEAD), the EF-86 and 12AX7 stages, as well as the low-level input sockets and associated wiring, should be suspected.

In many cases, hum will appear to be originating in the amplifier but is actually being picked up by the signal source, or is the result of a poor connection in the audio cable which connects the signal source to the amplifier. When considering hum, the primary concern should be with the hum heard at normal settings of the LEVEL control. It is normal to hear a very slight amount of hum and noise at the upper extreme setting of this control.

**DISTORTION:** Faulty tubes, a shorted coupling capacitor, or a resistor that has changed value can cause distortion. The tubes may be checked as previously suggested. An ohmmeter will prove helpful in checking for shorted capacitors and resistors that are out of tolerance.

**Loss of signal:** The three most common causes of signal loss are a faulty tube, a short circuit between the signal path and ground and an open coupling capacitor.

After checking the tubes, an ohmmeter can be used to check for short circuits. Most coupling capacitors have a very high leakage resistance,

therefore, an ohmmeter check would not be conclusive. Coupling capacitors are best checked on a capacitor tester or by direct substitution.

Another way to check for signal loss is by signal tracing. This is done by applying an audio voltage to an appropriate input either from an audio generator or from a high fidelity signal source and then checking progressively from the input jack at various points along the signal path with a signal tracer or an oscilloscope to determine at which point the appropriate signal is lost. After obtaining this information, the associated circuitry should be checked, as previously suggested.

If test instruments are not available for signal tracing, a .01 to .05  $\mu$ f capacitor can be used to find the stage that is not passing the applied signal. By holding one lead of this capacitor and touching the other lead to the control grid pin of each tube socket, a 60 cycle hum should be heard from the output. If, upon touching a grid pin, a hum is not heard, the associated circuitry should be suspected and thoroughly checked out.

## SERVICE INFORMATION

### SERVICE

If, after applying the information contained in this manual and your best efforts, you are still unable to obtain proper performance, it is suggested that you take advantage of the technical facilities which the Heath Company makes available to its customers.

The Technical Consultation Department is maintained for your benefit. This service is available to you at no charge. Its primary purpose is to provide assistance for those who encounter difficulty in the construction, operation or maintenance of HEATHKIT equipment. It is not intended, and is not equipped to function as a general source of technical information involving kit modifications nor anything other than the normal and specified performance of HEATHKIT equipment.

Although the Technical Consultants are familiar with all details of this kit, the effectiveness of their advice will depend entirely upon the amount and the accuracy of the information furnished by you. In a sense, YOU MUST QUALIFY for GOOD

technical advice by helping the consultants to help you. Please use this outline:

1. Before writing, fully investigate each of the hints and suggestions listed in this manual under "IN CASE OF DIFFICULTY." Possibly it will not be necessary to write.
2. When writing, clearly describe the nature of the trouble and mention all associated equipment. Specifically report operating procedures, switch positions, connections to other units and anything else that might help to isolate the cause of trouble.
3. Report fully on the results obtained when testing the unit initially and when following the suggestions under "IN CASE OF DIFFICULTY." Be as specific as possible and include voltage readings if test equipment is available.
4. Identify the kit model number and date of purchase, if available.
5. Print or type your name and address, preferably in two places on the letter.

With the preceding information, the consultant will know exactly what kit you have, what you would like it to do for you and the difficulty you wish to correct. The date of purchase tells him whether or not engineering changes have been made since it was shipped to you. He will know what you have done in an effort to locate the cause of trouble and, thereby, avoid repetitious suggestions. (The automatic letter opener sometimes cuts through the letter, hence the suggestion to print the name and address twice.) In short, he will devote full time to the problem at hand, and through his familiarity with the kit, plus your accurate report, he will be able to give you a complete and helpful answer. If replacement parts are required, they will be shipped to you, subject to the terms of the Warranty.

The Factory Service facilities are also available to you, in case you are not familiar enough with electronics to provide our consultants with sufficient information on which to base a diagnosis of your difficulty, or in the event that you prefer to have the difficulty corrected in this manner. You may return the completed instrument to the Heath Company for inspection and necessary repairs and adjustments. You will be charged a minimal service fee, plus the price of any additional parts or material required. However, if the completed kit is returned within the Warranty period, parts charges will be governed by the terms of the Warranty. State the date of purchase, if possible.

Local Service by Authorized HEATHKIT Service Centers is also available in some areas and often will be your fastest, most efficient method of obtaining service for your HEATHKIT equipment. Although you may find charges for local service somewhat higher than for factory service, the amount of increase is usually offset by the transportation charge you would pay if you elected to return your kit to the Heath Company.

HEATHKIT Service Centers will honor the regular 90 day HEATHKIT Parts Warranty on all kits, whether purchased through a dealer or directly from Heath Company; however, it will be necessary that you verify the purchase date of your kit.

Under the conditions specified in the Warranty, replacement parts are supplied without charge; however, if the Service Center assists you in locating a defective part (or parts) in your kit, or installs a replacement part for you, you may be charged for this service.

HEATHKIT equipment purchased locally and returned to Heath Company for service must be accompanied by your copy of the dated sales receipt from your authorized HEATHKIT dealer in order to be eligible for parts replacement under the terms of the Warranty.

**THIS SERVICE POLICY APPLIES ONLY TO COMPLETED EQUIPMENT CONSTRUCTED IN ACCORDANCE WITH THE INSTRUCTIONS AS STATED IN THE MANUAL.** Equipment that has been modified in design will not be accepted for repair. If there is evidence of acid core solder or paste fluxes, the equipment will be returned NOT repaired.

For information regarding modification of HEATHKIT equipment for special applications, it is suggested that you refer to any one or more of the many publications that are available on all phases of electronics. They can be obtained at or through your local library, as well as at most electronic equipment stores. Although the Heath Company sincerely welcomes all comments and suggestions, it would be impossible to design, test, evaluate and assume responsibility for proposed circuit changes for special purposes. Therefore, such modifications must be made at the discretion of the kit builder, using information available from sources other than the Heath Company.



## REPLACEMENTS

Material supplied with HEATHKIT products has been carefully selected to meet design requirements and ordinarily will fulfill its function without difficulty. Occasionally improper instrument operation can be traced to a faulty component. Should inspection reveal the necessity for replacement, write to the Heath Company and supply all of the following information.

- A. Thoroughly identify the part in question by using the part number and description found in the manual Parts List.
- B. Identify the type and model number of kit in which it is used.
- C. Mention date of purchase.
- D. Describe the nature of defect or reason for requesting replacement.

The Heath Company will promptly supply the necessary replacement. PLEASE DO NOT RETURN THE ORIGINAL COMPONENT UNTIL SPECIFICALLY REQUESTED TO DO SO. Do not dismantle the component in question as this will void the guarantee. This replacement policy does not cover the free replacement of parts that may have been broken or damaged through carelessness on the part of the kit builder.

## SHIPPING INSTRUCTIONS

In the event that your instrument must be returned for service, these instructions should be carefully followed.

Return complete amplifier with all tubes and audio cables. Remove the feet from the bottom plate and then make sure that the bottom plate and cabinet shell are secured properly before packing.

ATTACH A TAG TO THE EQUIPMENT BEARING YOUR NAME, COMPLETE ADDRESS, DATE OF PURCHASE, AND A BRIEF DESCRIPTION OF THE DIFFICULTY ENCOUNTERED. Wrap the equipment in heavy paper, exercising care to prevent damage. Place the wrapped equipment in a stout carton of such size that at least three inches of shredded paper, excelsior, or other resilient packing material can be placed between all sides of the wrapped equipment and the carton. Close and seal the carton with gummed paper tape, or alternately, tie securely with stout cord. Clearly print the address on the carton as follows:

To: HEATH COMPANY  
Benton Harbor, Michigan

Include your name and return address on the outside of the carton. Preferably affix one or more "Fragile" or "Handle With Care" labels to the carton, or otherwise so mark with a crayon of bright color. Ship by parcel post or prepaid express; note that a carrier cannot be held responsible for damage in transit if, in HIS OPINION, the article is inadequately packed for shipment.

## WARRANTY

Heath Company warrants that for a period of three months from the date of shipment, all Heathkit parts shall be free of defects in materials and workmanship under normal use and service and that in fulfillment of any breach of such warranty, Heath Company shall replace such defective parts upon the return of the same to its factory. The foregoing warranty shall apply only to the original buyer, and is and shall be in lieu of all other warranties, whether express or implied and of all other obligations or liabilities on the part of Heath Company and in no event shall Heath Company be liable for any anticipated profits, consequential damages, loss of time or other losses incurred by the buyer in connection with the purchase, assembly or operation of Heathkits or components thereof. No replacement shall be made of parts damaged by the buyer in the course of handling or assembling Heathkit equipment.

NOTE: The foregoing warranty is completely void and we will not replace, repair or service instruments or parts thereof in which acid core solder or paste fluxes have been used.

HEATH COMPANY

## BIBLIOGRAPHY

Crowhurst, Norman, "Stereophonic Sound" (Rider).

Fowler, Charles, "High Fidelity - A Practical Guide" (Audiocom).

"The Saturday Review Home Book of Recorded Music and Sound Reproduction" (Prentice-Hall).

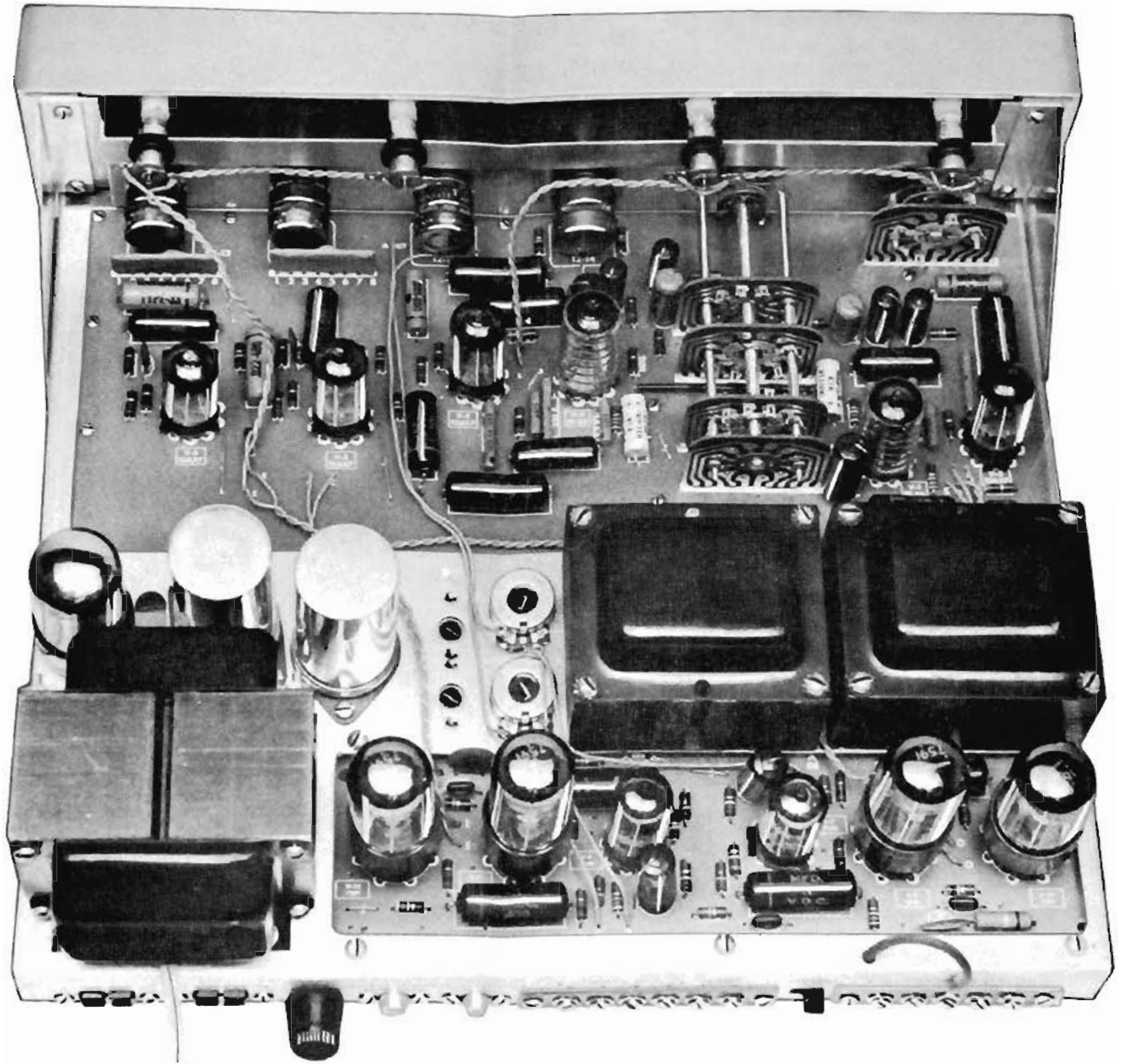

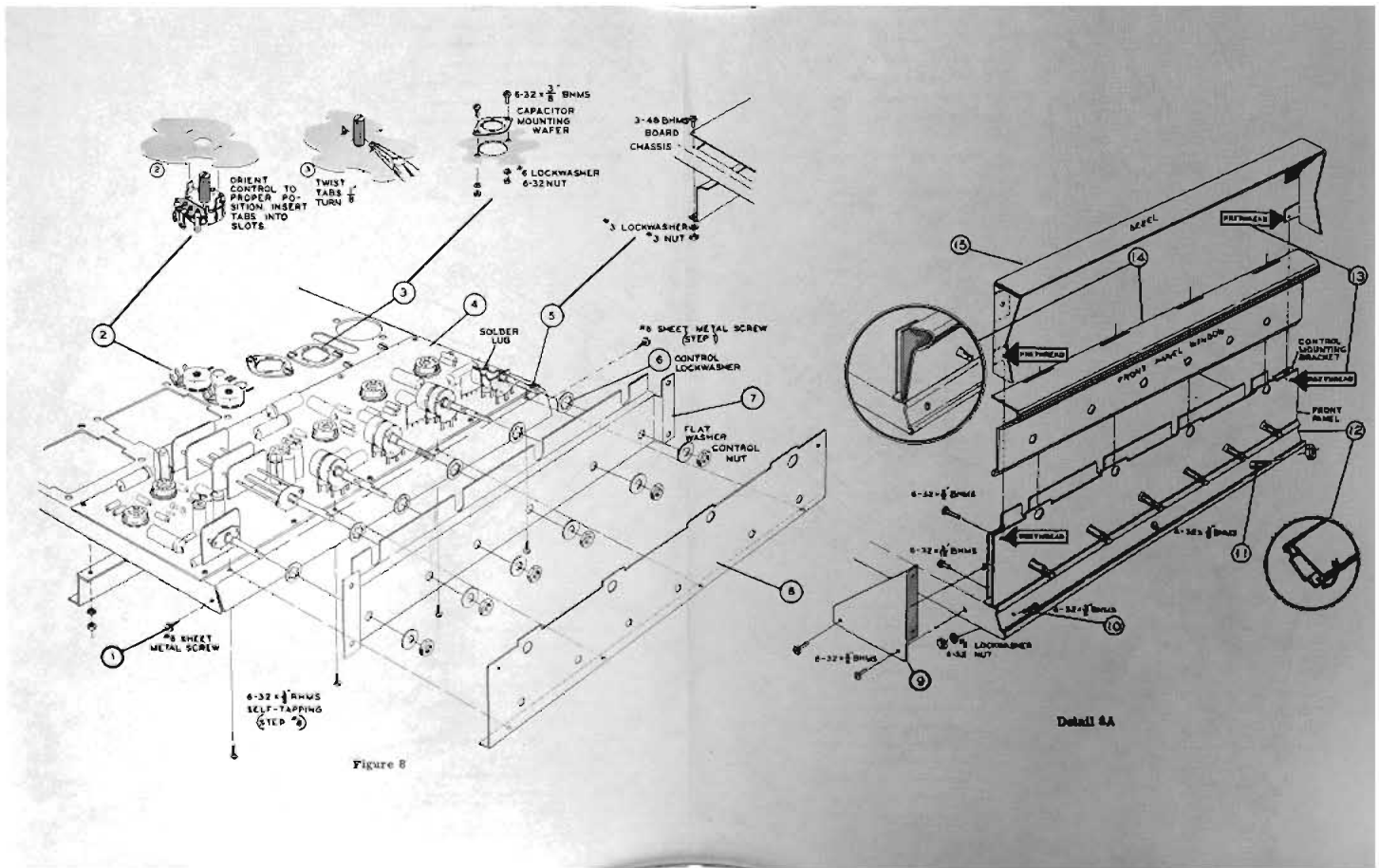





NOTE: The low-noise resistors supplied with your kit may be greater in length than the hole spacing on the circuit board. In such cases, a little extra care in positioning the resistors will result in neat installation. The illustrations below show how this should be done.

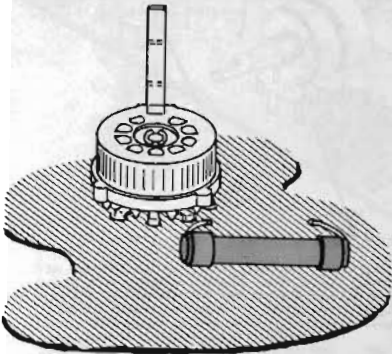

Detail 5A



IF NECESSARY TO AVOID CONTACT WITH TUBE SOCKET, POSITION RESISTOR TO ONE SIDE (DETAIL 5A) OR TO ONE END (DETAIL 5B) AS APPROPRIATE.

Detail 5B

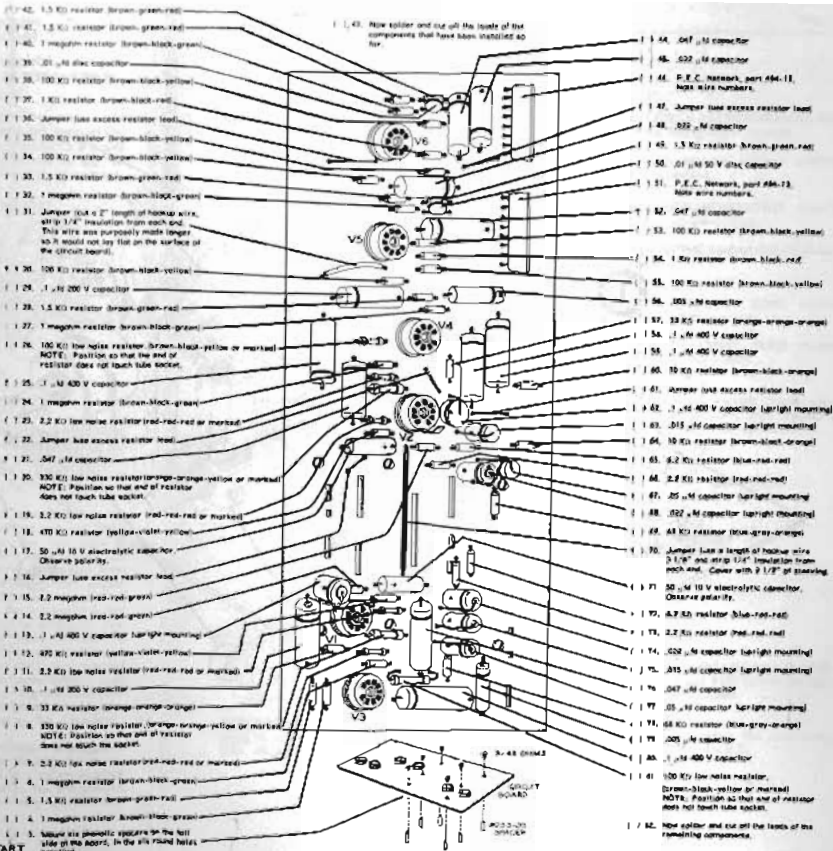

Figure 5

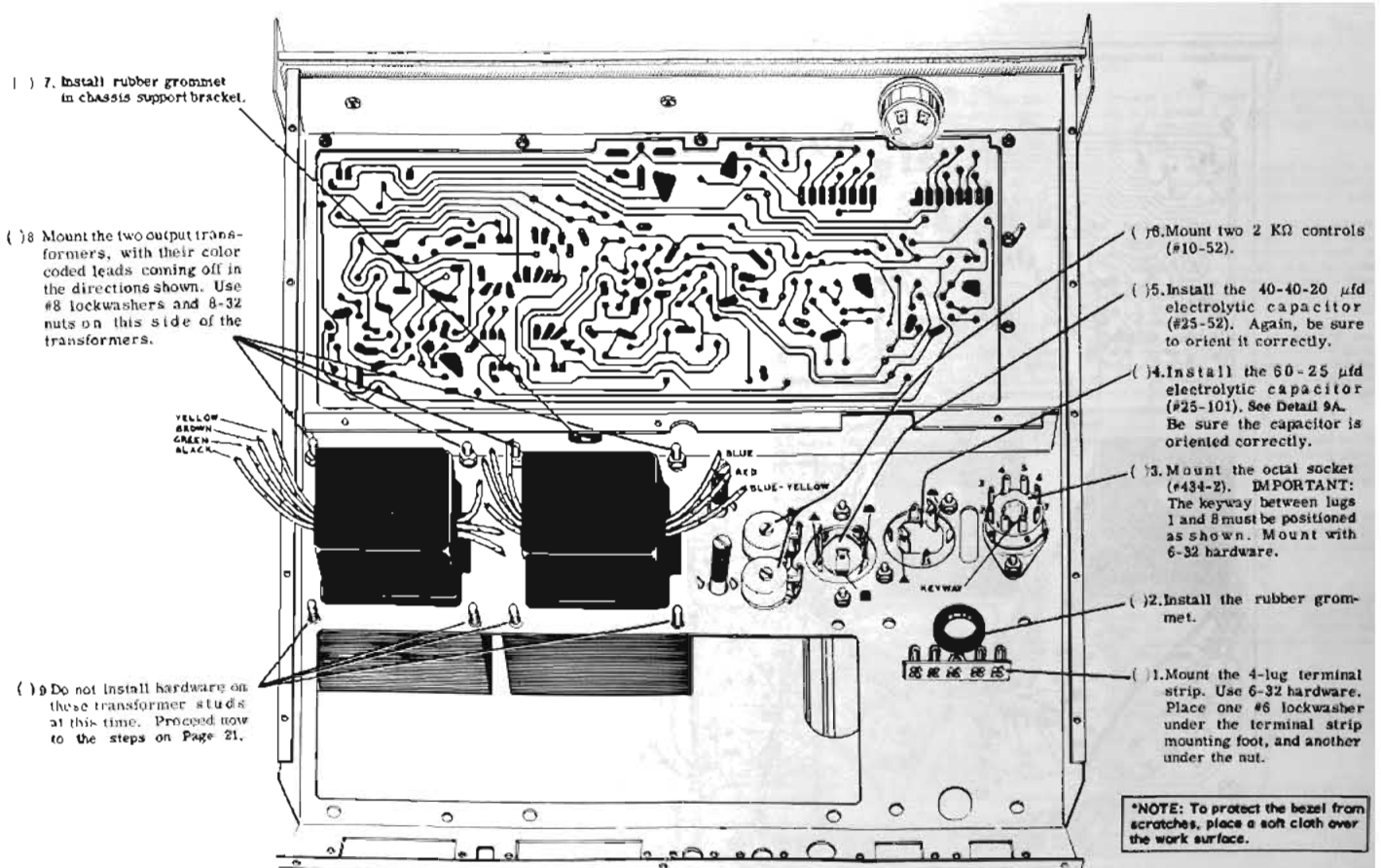
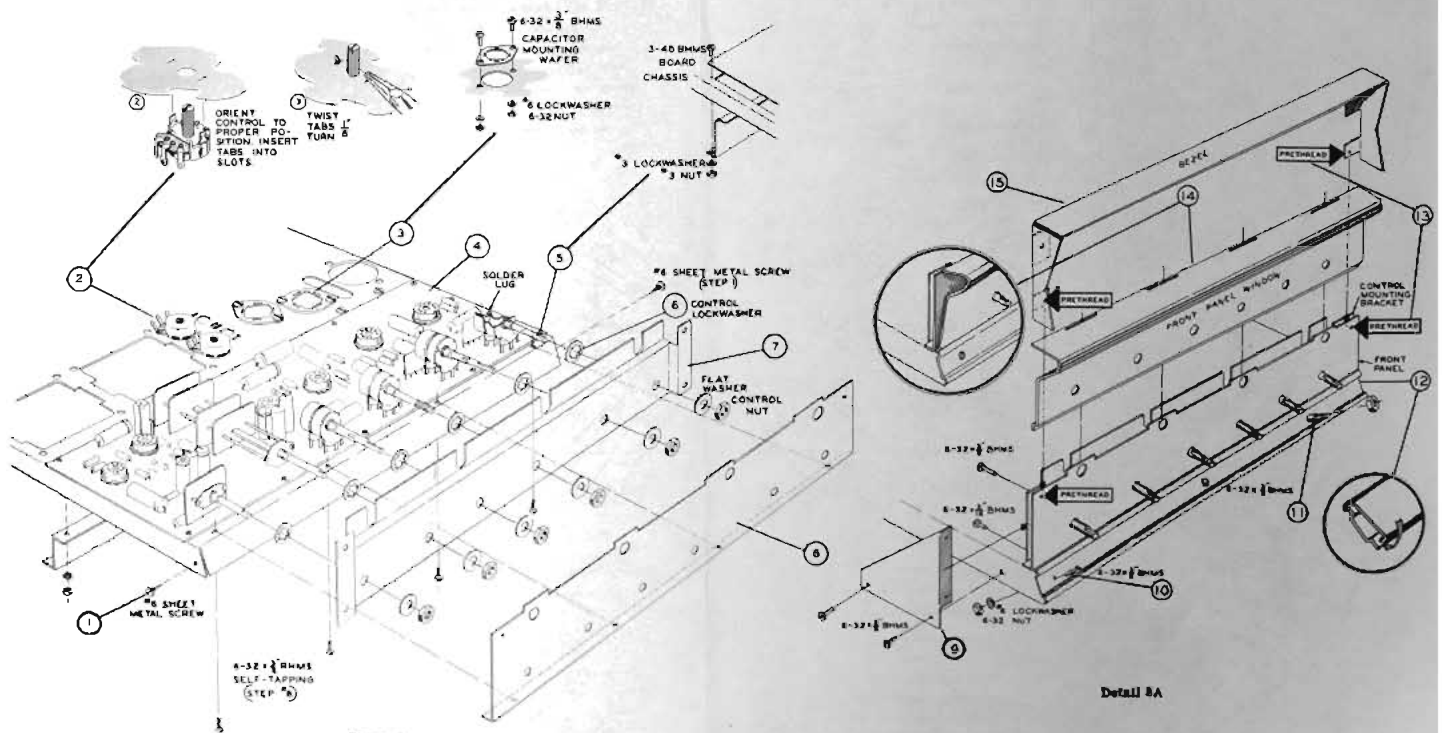

Figure 9





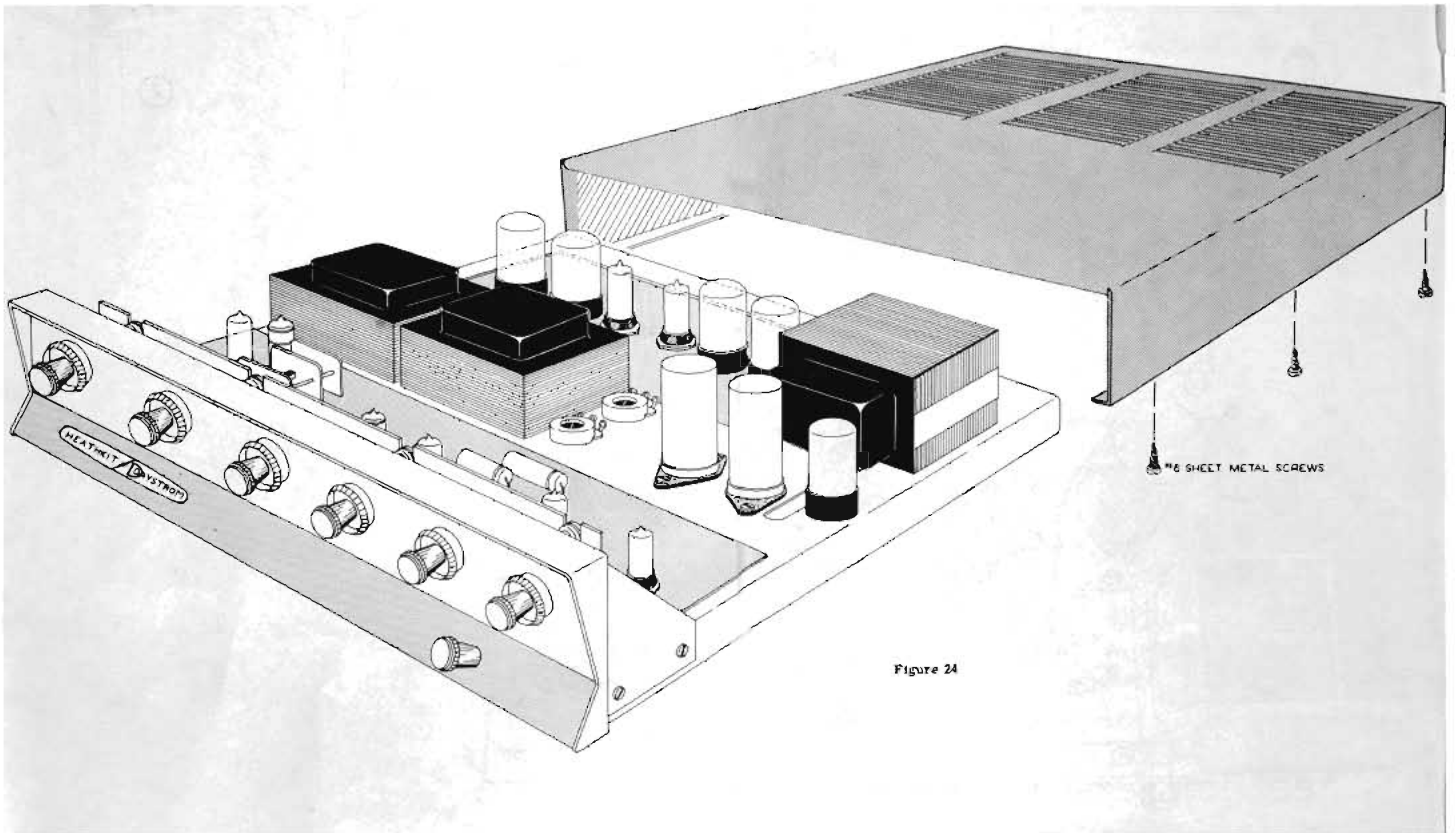

Figure 24