

AN-10

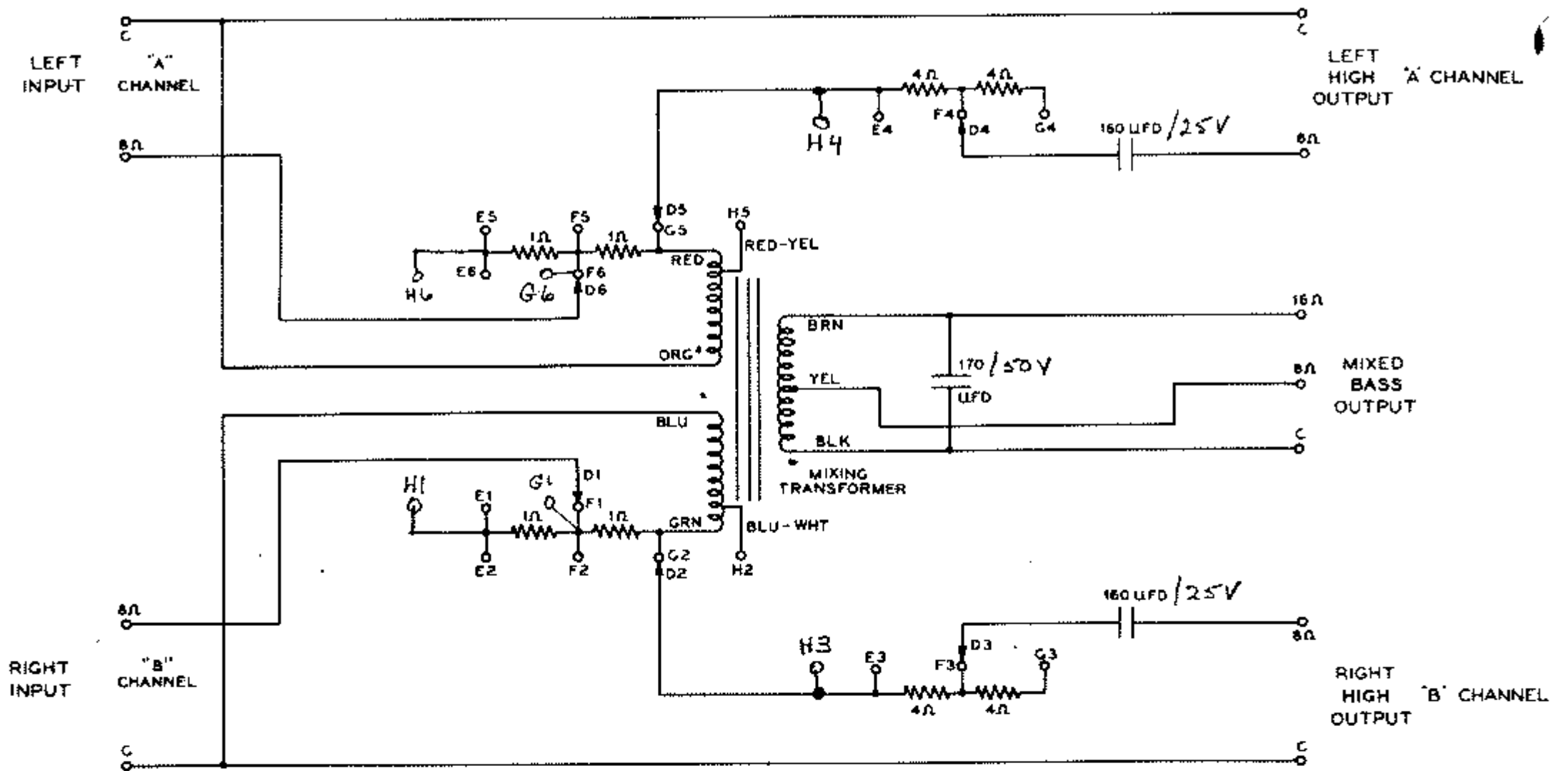

ALL RESISTORS - 7W

HEATHKIT®
MIXED LOWS STEREO
CROSSOVER
MODEL AN-10

Schematic Diagram

CIRCUIT DESCRIPTION

The HEATHKIT® Model AN-10 Mixed Lows Stereo Crossover consists basically of two high-pass filter networks and a low-pass, channel combining filter network. The level of the low-pass filter output relative to the high-pass filter outputs can be adjusted in four steps. This adjustment is used to provide the correct proportion between the acoustical output from the bass speaker and the acoustical outputs from the high frequency speakers. Refer to Figure 1 and the Schematic Diagram.

The two high-pass filters each consist of a single 160 µfd capacitor. These high-pass filters have a maximum attenuation slope of 6 db per octave below 250 cps.

Frequencies above 250 cps are transferred from the left and right amplifier outputs, through the high-pass filters, to the left and right high frequency speakers, respectively. It has

been found that the stereo effect depends mainly on these higher frequencies; therefore, if the output power levels of the two amplifiers are equal and if the high frequency speakers are identical, a true stereo effect will result when the high frequency speakers are placed sufficiently away from each other.

The secondary winding of the mixing transformer and a 170 µfd capacitor form the low-pass filter which has a maximum attenuation slope of 12 db per octave above 250 cps. This filter allows the frequencies below 250 cps, from both amplifier outputs, to reach the bass speaker for reproduction. Higher frequencies are, in effect, cut off from the bass speaker. Since it has been found that frequencies below 250 cps do not contribute to the stereo effect, the bass speaker can be placed at any convenient location without changing the stereo orientation of the high frequency speakers.