



111 Powdermill Road, Maynard, Mass.

SERVICE BULLETIN
For
MODEL 222C STEREO AMPLIFIER

SPECIFICATIONS

Table with specifications for Model 222C Stereo Amplifier, including maximum power output, harmonic distortion, frequency response, and power bandwidth.

(These characteristics are measured at a line voltage of 117 volts rms and line frequency of 60 cycles per second. No significant changes of characteristics should be experienced for normal variations of line voltages or a line frequency of 50 cycles per second).

* All H. H. Scott amplifiers and preamplifiers incorporate a sharp cutoff filter (12 db. or sharper per octave) which becomes fully operative below 20 cycles. This is designed to prevent overload of the output stage and the loudspeaker due to subsonic rumble frequencies and record eccentricity.

GENERAL SERVICE NOTES

1. Check the tubes, particularly those in the power output stage and the rectifier every year. If the tubes are outside the manufacturer's ratings or show gas, they should be replaced. Gassy tubes may damage other components of the circuit.
2. When the amplifier is being checked yearly, clean the tubes of dust so that they may radiate their heat more effectively.
3. If at any time the hum or noise increases noticeably, check the power tubes. This symptom is often an indication of gassy tubes.
4. If the amplifier blows fuses frequently, check the line voltage. If it rises above 125 volts, drop the line voltage by means of an auto-transformer or place a voltage regulator transformer between the amplifier and the line. If the line voltage is correct, check the amplifier itself. Do not use fuse sizes other than the fuse size specified.
5. D.C. Balance Adjustment:

Equipment Needed - Oscilloscope and/or AC VTVM, 16 ohm resistive load of adequate wattage (some wirewound resistors have considerable residual inductance and these should be avoided).

The balance pot for each output stage is located between the output tubes for that stage. These controls should be adjusted when the output tubes age appreciably or are replaced. To set these controls use the following procedure:

- (a) Connect the 16 ohm resistor across the output terminal of the channel under test.
- (b) Connect the oscilloscope and/or VTVM across the resistor, and turn the horizontal selector of the scope to "LINE".
- (c) Remove the phase inverter tube 6U8/6GH8 of the output stage under test.
- (d) Adjust the proper D.C. Balance Control for a minimum 120 cycle response on the scope or minimum reading on the AC VTVM.
- (e) Repeat the entire procedure for the other amplifier output stage.

6. Tests can be performed to insure that the unit meets or exceeds the specifications outlined previously. Only use parts and tubes specified by H. H. Scott, Inc. The use of non-standard parts or tubes will preclude obtaining the performance stated in the specifications.

If you have any further questions, write to:

Technical Services Dept.
 H. H. Scott, Inc.
 111 Powder Mill Road
 Maynard, Massachusetts

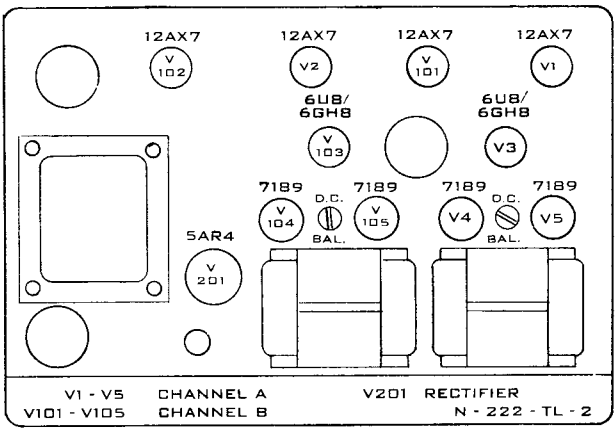

POSITION	FUNCTION
1.	BALANCE "A"
2.	BALANCE "B"
3.	MONOPHONIC RECORDS
4.	STEREO
5.	REVERSE STEREO
6.	CHANNEL "A"
7.	CHANNEL "B"

POSITION	FUNCTION
1.	PHONO
2.	TUNER
3.	EXTRA

POSITION	FUNCTION
1.	RIAA - NAB - ORTHO
2.	NAB TAPE

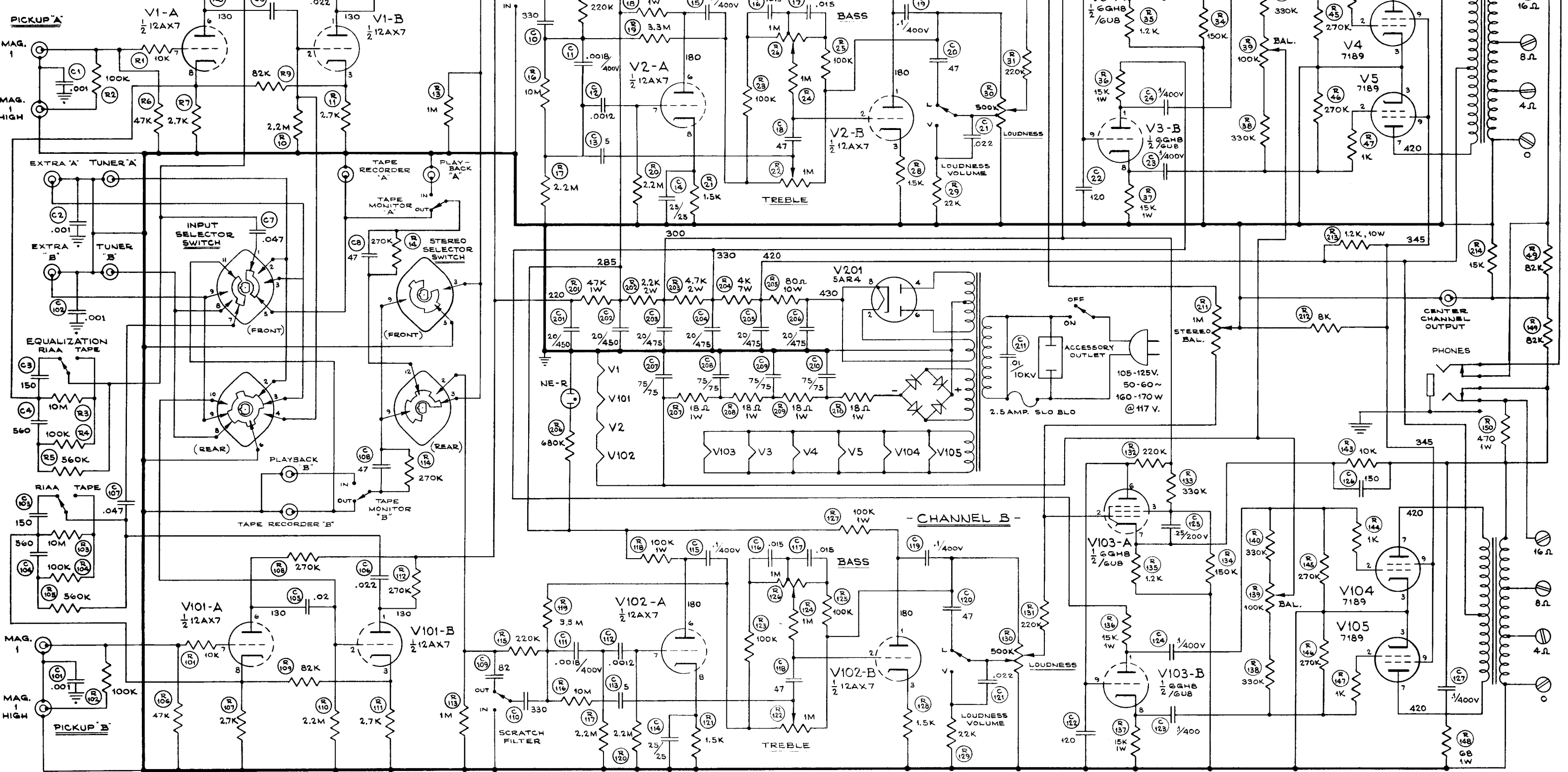

REVISIONS	DATE	BY	DESCRIPTION
1	10/19/61	J.C.	CHANGED PER ECO 10/19/61
2	10/19/61	J.C.	REVISOR PER ECO 10/19/61
3	10/27/61	J.C.	REVISOR PER ECO 10/27/61
4	11/2/61	J.C.	REVISOR PER ECO 11/2/61
5	3-15-62	J.C.	FCO # 580
6	7-16-62	J.C.	REVISOR PER ECO 7-16-62

THE FOLLOWING CONTROLS IN CHANNEL "A" ARE MECHANICALLY GANGED WITH IDENTICAL CONTROLS IN CHANNEL "B".....

1. INPUT SELECTOR
2. EQUALIZATION
3. SCRATCH FILTER
4. LOUDNESS - VOLUME
5. LOUDNESS AND POWER SWITCH

TYPE 222C STEREO AMPLIFIER

UNLESS OTHERWISE SPECIFIED

SCALE: ~

19 JULY 1961

222C CIRCUIT DIAGRAM

H. H. SCOTT, INC.
MAYNARD, MASS., U.S.A.

DR. CASSIDY ENG.

CH. PROD.

DWG NO. D-222C-C1.6