

**SERVICE MANUAL**  
**FOR**  
**2506/07 COMPACT**



Scott . . . where innovation is a tradition



H. H. Scott, Inc. 111 Powdermill Road, Maynard, Mass., 01754

## AUDIO SECTION TEST

### Set Controls to the Following:

SP-2	OFF
Input Selector	Extra
Mode Switch	Stereo
Tone Controls	Flat "0"
Loudness	Full CCW
Vol. Comp.	Loud
Sp-1	ON
Balance Pot.	"0"
Power	ON

### 1. Offset, Bias and Voltage Checks

Check main supplies for +17 volts and -17 volts  $\pm 10\%$ . At the emitter of the QP-11, on the main chassis, check for 12 VDC.

Bias measurements are to be made with meter directly across either .82 ohm resistor on driver board. Adjust bias pot (pot nearest rear panel) for .6mA.

### 2. Sensitivity Check

Audio osc. to EXTRA at .40 (+2 dB) input. Connect 8 ohm load to SP-1 jacks. Turn loudness pot to max., observe output of 16.1W (8V). Check tape output jack with trouble-shooting lead for same input signal as above.

### 3. Distortion Check

At 8V output max. distortion 0.6% @ 400 Hz.

### 3a. Balance Pot

With input and output connected to left channel, note loss of 0 dB when pot is rotated to "L" position. When pot is rotated to "R", note a 45 dB drop in output. With input and output in the right channel, pot rotation to "R" will indicate no drop in output, and in "L" position a 45 dB drop will occur.

### 4. Tape Monitor Switch Check

Audio osc. to EXTRA at .40v input to L channel. Note output at left channel speaker terminal. Put tape monitor switch in the IN position. Note loss of output. Connect jumper cable from L channel tape OUT to L channel tape IN. Note restoration of signal out. Repeat process for R channel, then return tape monitor switch to OUT position.

### 5. Speaker Switch & Phone Jack Check

SP #1 switch to OFF position. Note complete loss of signal. Loudness to min. Insert phone plug to phone jack, remove speaker leads and connect to phone plug leads. Loudness to max. Note drop of  $26 \pm 2$  dB. Switch # 1 speakers in. Return speaker leads to output jacks. Note restoration of signal. 8 ohm load to speaker #2 jacks. Speaker # 1 switch OFF, speaker # 2 switch ON, note same output as # 1 speakers. With speaker # 1 and speaker # 2 switches ON, note drop in output of 1 to 2 dB. Return speaker switch to speaker # 1 ON and speaker # 2 OFF and load to speaker # 1 jacks.

### 6. Loudness Volume Check

Loudness vol. sw. to LOUD pos. Loudness pot to 4 flat pos., osc. to 1 kHz. Take ref. Osc. to 100 Hz. Note rise of  $7 \pm 2$  dB. Loudness vol. sw. to VOL. pos., osc. to 1 kHz. Take ref. At 100 Hz and 10 kHz note  $0 \pm 2$  dB from original ref. Loudness pot to max., osc. at 1 kHz, output 8V. Loudness pot to min. Note drop of 70 dB. Loudness pot to max.

**7. Tracking Check**

In 10 dB steps check tracking of L & R channels. Output may be no more than 3 dB between channels down to 40 dB down.

**8. Crosstalk and Stereo Switch Check**

At 1 kHz loudness pot to max., adjust output to 0 dB on 3V scale, mono-stereo switch to STEREO. Remove input and place in opposite channel, output from opposite channel should be down 45 dB. Return controls to previous settings.

**9. Tone Control Check (0 dB IV range)**

Bass 100 Hz		Treble 10 kHz	
Boost	- 10 dB $\pm$ 2 dB	Boost	- 10 dB $\pm$ 2 dB
Cut	- 10 dB $\pm$ 2 dB	Cut	- 10 dB $\pm$ 2 dB

**10. Filter Response**

With 0 dB ref. @ 1 kHz, switch filter IN and check for output attenuation 10 dB  $\pm$  2 @ 10 kHz.

**11. Frequency Response Check (approx. 1 watt level)**

Osc. 0 dB 1 kHz reference on IV range. Sweep osc. from 35 Hz to 20 kHz, note maximum variation of  $\pm$  2 dB. 3 dB down point 20 Hz or lower  
3 dB down point 25-65 kHz

**12. Regulation Check**

At 1 kHz 0 dB IV range remove 8 ohm load switch. Output rise of 1 dB max.

**13. Preamp Gain Check @ 1 kHz**

Attenuate input 44 dB, input leads to phono. Output 0 dB IV range  $\pm$  1 dB. Stereo mono switch to MONO, note drop of 1 dB in output. Stereo-mono switch to STEREO.

Selector switch to MIC position. Output 0 dB  $\pm$  1 dB. Stereo-mono switch to MONO, note drop of 6 dB in output. Stereo-mono switch to STEREO.

**14. Preamp Frequency Response Check**

Phono		MIC	
1 kHz	0 dB (ref)	1 kHz	0 dB (ref.)
10 kHz	-13 $\pm$ 2 dB	10 kHz	0 dB
100 Hz	+13 $\pm$ 2 dB	100 Hz	0 dB

**15. Hum Checks (input shorted)**

Position	Loudness Pot	Max Hum
Extra	0	5 mV
Extra	10	5 mV
Phono	10	15 mV
MIC	10	15 mV

**16. Repeat steps 2 through 15 for R channel.**

CIRCUIT DIAGRAM 100-1333-013

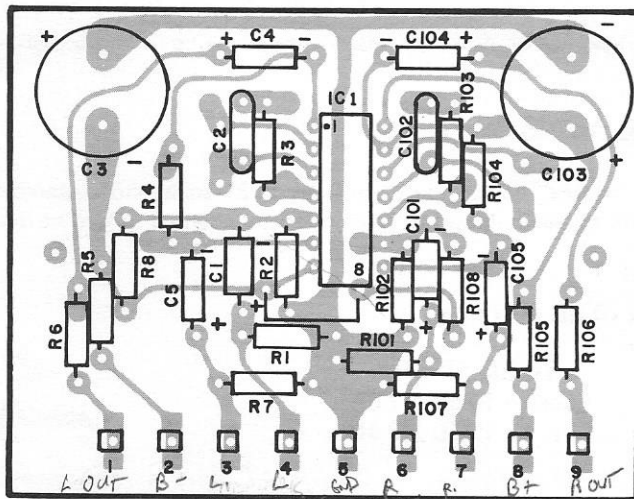

PRE AMP

NOTE:

1. CIRCLE MARK ON TOP OR INDENTATION ON LEG OF IC INDICATES PIN NO.1

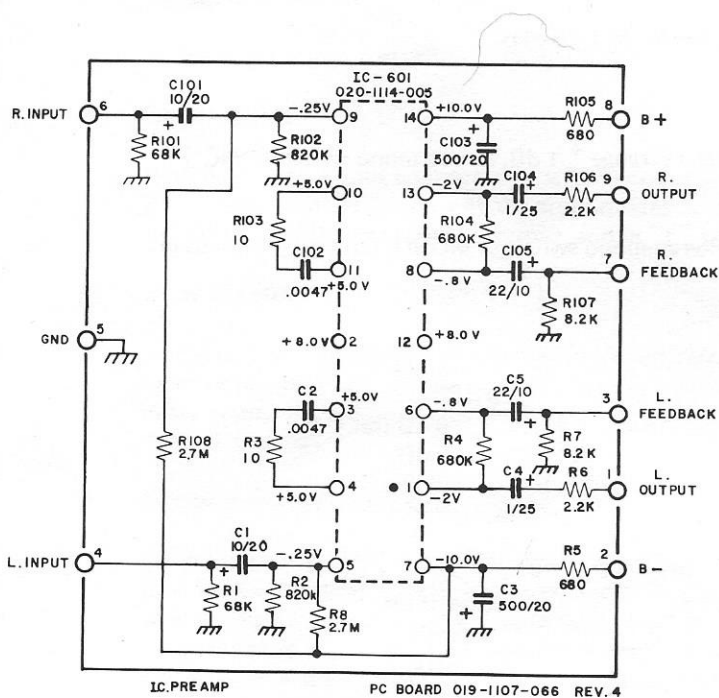

NOTES:

1. UNLESS OTHERWISE SPECIFIED, ALL RESISTANCE IN OHMS,  $\pm 10\%$ , 1/4 WATT, CAPACITANCE IN MICROFARADS.
2. HIGHEST SERIES NUMBERS ARE: R8, R108, C5, C105, IC-601.
3. CIRCLE MARK ON TOP OR INDENTATION ON LEG OF IC INDICATES PIN NO.1.
4. VOLTAGES SHOWN DO NOT APPLY TO 2506-07.

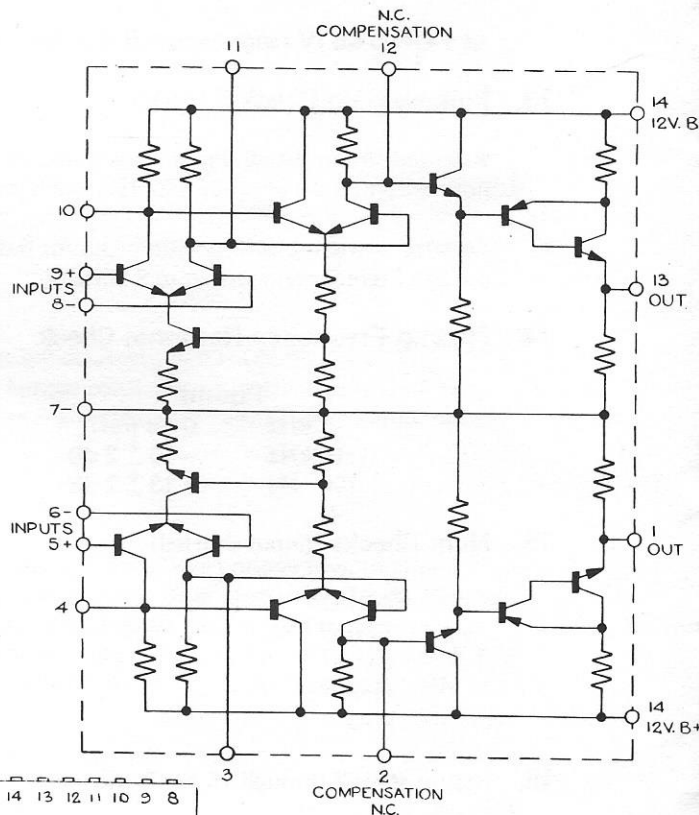

CIRCUIT DIAGRAM SC-5116 (020-1114-005)

Q1, Q101, 020-1112-005

CIRCUIT DIAGRAM 100-1334-006

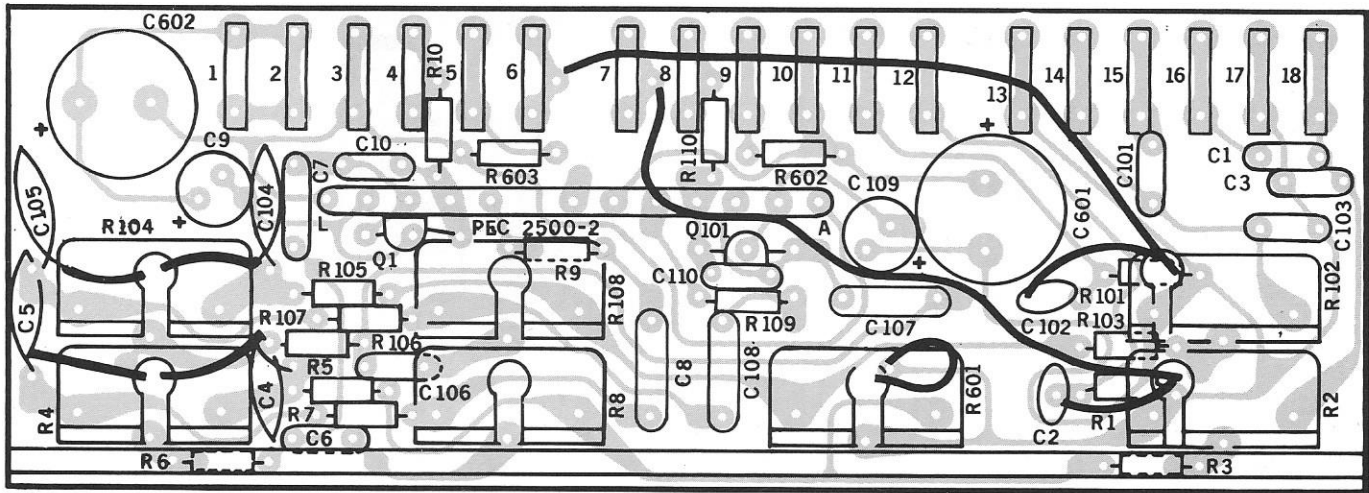

TONE CONTROL & LOUDNESS

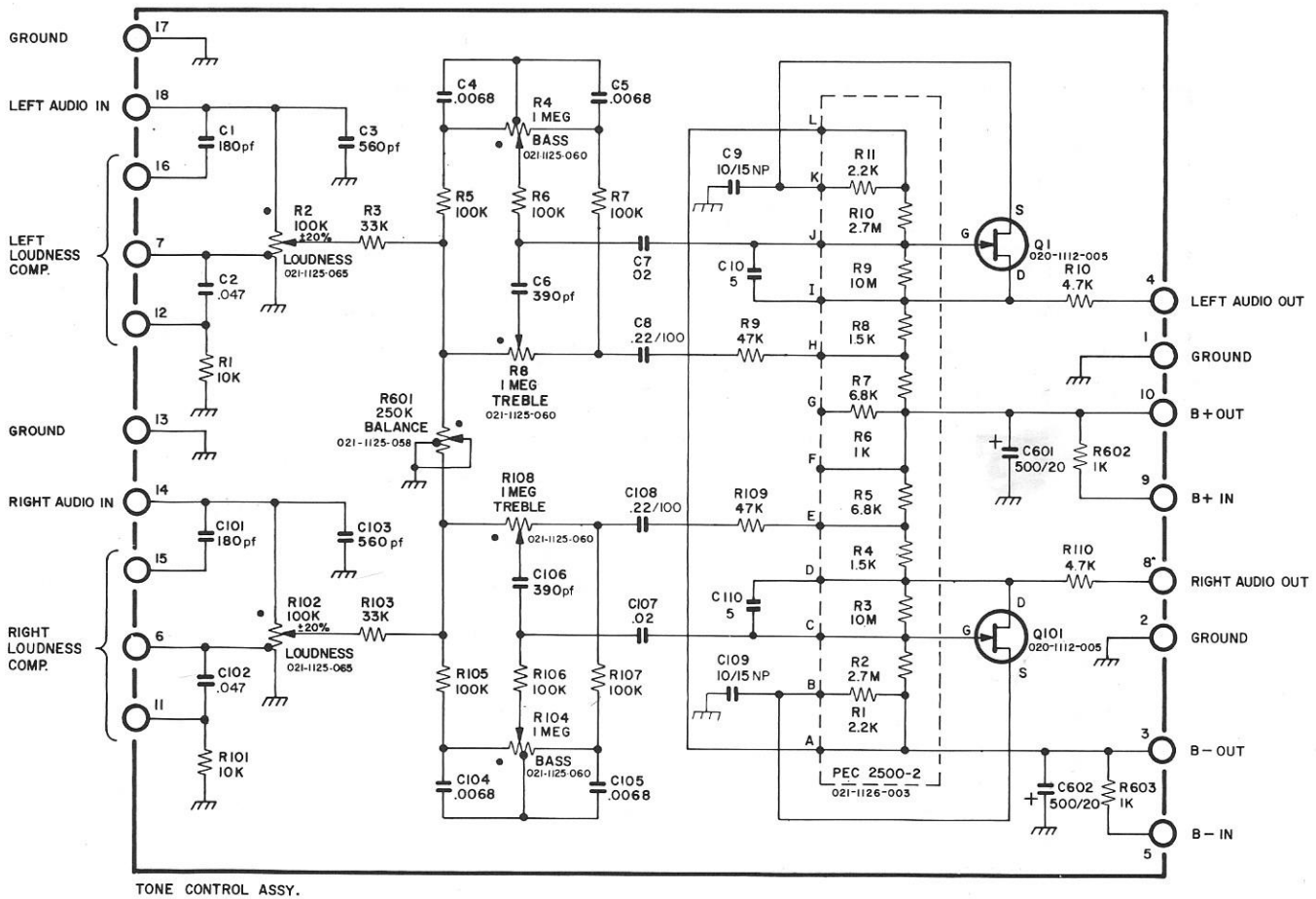

TONE CONTROL ASSY.

- NOTES:
1. UNLESS OTHERWISE SPECIFIED: RESISTANCE IN OHMS  $\pm 10\%$  1/4 WATT, AND CAPACITANCE IN MFD'S.
  2. DOT ON POTENTIOMETER INDICATES EXTREME CW POSITION VIEWED FROM KNOB END.
  3. HIGHEST SERIES NO'S ARE: R10, R110, R603, C10, C101, C602, Q1, Q101
  4. WHEN TONE CONTROLS ARE IN FLAT POSITION, THE OVERALL VOLTAGE GAIN OF THIS CIRCUIT IS APPROXIMATELY UNITY. (0db)
  5. THE FOLLOWING CONTROLS IN THE LEFT CHANNEL ARE MECHANICALLY CONNECTED TO IDENTICAL CONTROLS IN THE RIGHT CHANNEL, LOUDNESS, BALANCE, TREBLE, BASS.

Q301, QA-21, 020-1110-005  
 Q302, QA-19, 020-1110-017  
 Q303, QA-16, 020-1110-014  
 Q304, S2209, 020-1110-004  
 Q305, 2901, 020-1111-011  
 Q306, 2801, 020-1111-010

CIRCUIT DIAGRAM 100-1349-002 Rev. 1

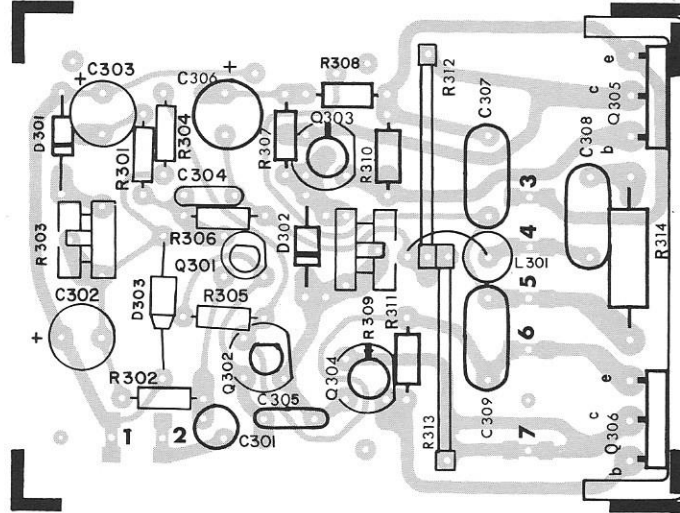

POWER AMP. DRIVER

019-1107-065/A Rev. 0

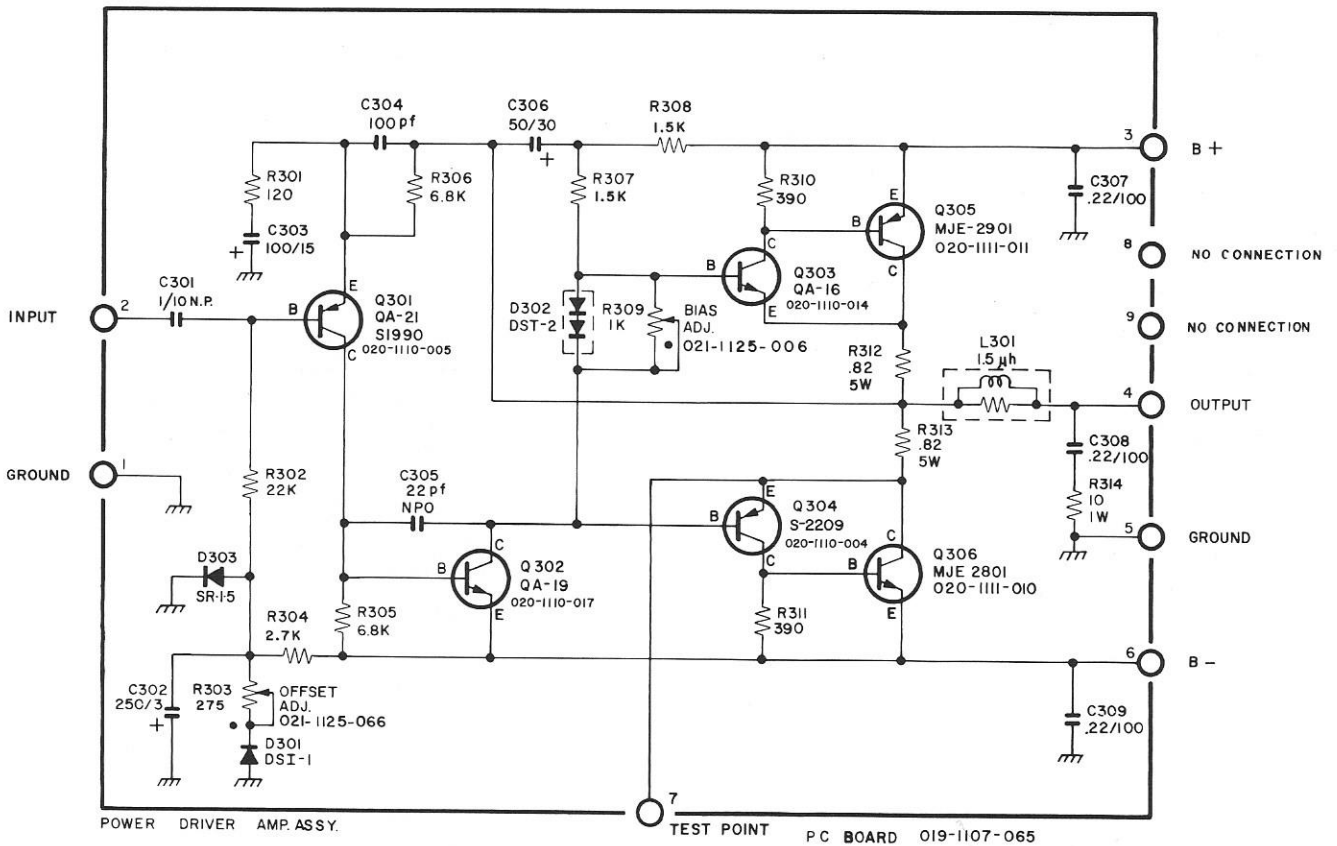

POWER DRIVER AMP. ASSY.

TEST POINT PC BOARD 019-1107-065

NOTES:

1. UNLESS OTHERWISE SPECIFIED- ALL RESISTANCE IN OHMS,  $\pm 10\%$ , 1/4 WATT, CAPACITANCE IN MFD'S.
2. HIGHEST SERIES NUMBERS ARE: R314, C309, D303, Q306, L301
3. DOT ON POTENTIOMETER INDICATES EXTREME CW POSITION VIEWED FROM KNOB END.

## AM-FM FRONT END (100-1330-017)

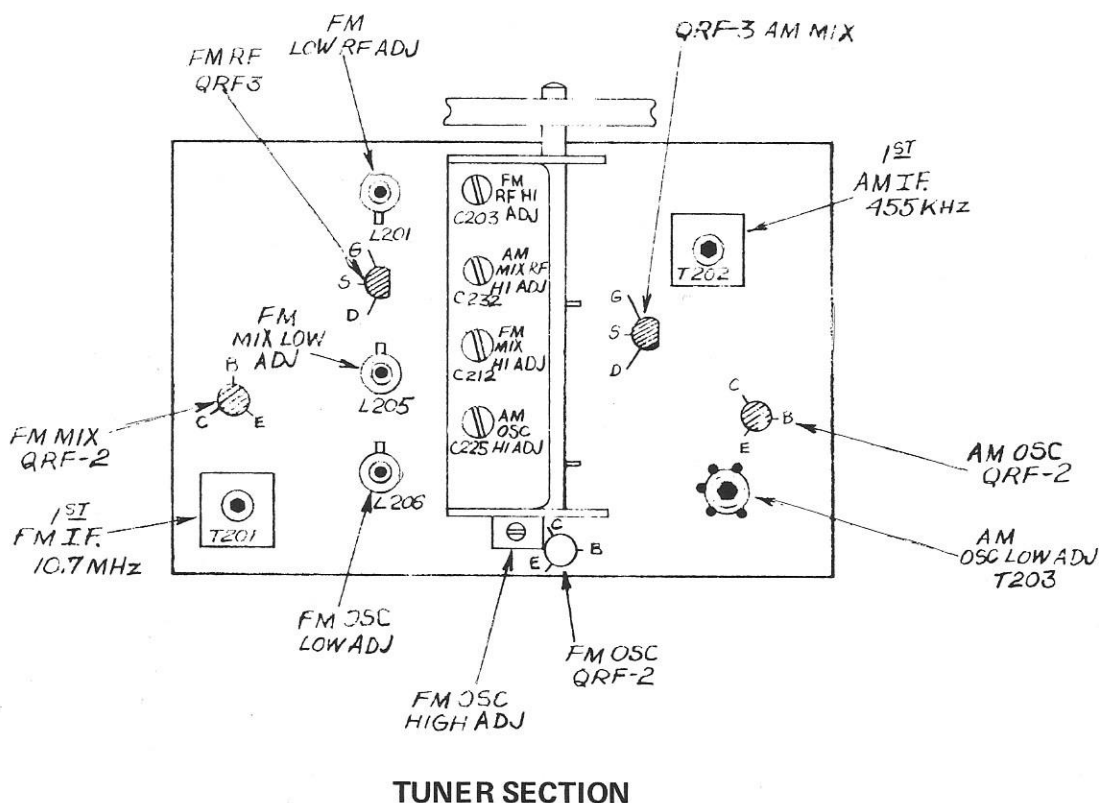
**Set Controls to the Following:**

Separation Pot	Max CCW
Input Select. Switch	FM

**PRELIMINARY CHECKS**

Make certain all transistors are firmly seated in correct sockets. Take output from Tape Out jacks.

**1. Mono Alignment and Sensitivity Check****Front End and IF Alignment**

With about 10 uV generator output, align and peak front end for max. output. With 1 or 2 K uV input, align detector. Bottom slug for max. audio output and top slug for min. distortion and perfect tune light to light.

**2. Sensitivity and Distortion**

Measure sensitivity of tuner with 3 uV rf input. Must obtain 30 dB usable sensitivity at 92, and 106 MHz. Recheck distortion, 2 K uV input. 400 Hz — max. distortion of 0.8%. Audio output spec. at 1 K 1.5 to 2.5 V.

**3. FM Hum Check**

Tune to 91.5 MHz, measure min. of 55 dB (may reverse ac plug), unmodulated carrier.

**De-emphasis Check**

Tune to 90 MHz (change mod. to 8 kHz), note decrease of  $12 \pm 2$  dB in output.

**Calibration Check**

Check calibration against stations — max. tolerance  $\pm 2$  MHz.

### 1. Preliminary 455 kHz Alignment

Set Tuning to middle of AM band, 1000 kHz. Output from Left Tape Out jack. Input from 455 kHz generator (modulated to 30% with 400 kHz) to External AM Antenna Inputs (shorting bar removed). With 2  $\mu\text{V}$  or less generator output peak the first IF can (T202) for maximum output (single tuned can). After peaking, remove 455 kHz generator leads and *reconnect* external AM antenna shorting bar.

### 2. Oscillator Adjustment

With tuning condenser maximum capacity (fully closed) adjust pointer to "0" on logging scale (center of pointer aligned with center of "0"). Couple output of AM generator (600 kHz modulated to 60% with 400 Hz) to loopstick with AM coupling loop, using mechanical stop for 1" penetration of loopstick. Tune unit to 600 kHz. Attenuate input of rf signal until signal level is just noticeable on scope (using maximum usable scope sensitivity). Adjust oscillator coil T203 while manually tuning unit for output peak as read on VTVM. Set AM generator to 1600 kHz modulated to 60% with 400 Hz.

Tune unit to 1600 kHz. Adjust oscillator trimmer C225 for maximum output as read on VTVM using weak rf input signal.

Repeat the above adjustments of oscillator coil and oscillator trimmer until no further improvement can be made.

### 3. Antenna Trimmer Adjustment

Set AM generator to 1400 kHz modulated to 60% with 400 Hz. Tune unit to 1400 kHz. Adjust antenna trimmer C232 for maximum output as read on VTVM using weak rf input signal.

### 4. 600 kHz Measurements

With unit tuned to 600 kHz and AM coupling loop set for 1" penetration, set rf attenuator for an input to the AM coupling loop equivalent to 500  $\mu\text{V}$ . Note audio output – should be between .75 and 1.25 volts from Tape Out jacks. Attenuate rf input to (approx. 10.0  $\mu\text{V}$ ). Check audio output which should not drop more than 3.0 dB from that noted for input equivalent to 500  $\mu\text{V}$ .

### 5. 1000 kHz Measurements

(a) With unit tuned to 1000 kHz and AM coupling loop set for 1" penetration, set rf attenuator for an input to the AM coupling loop equivalent to 500  $\mu\text{V}$ . Note audio output – should be between .75 and 1.25 volts from Tape Out jacks. Attenuate rf input to approx. 10.0  $\mu\text{V}$ . Check audio output which should not drop more than 3.0 dB from that noted at 500  $\mu\text{V}$ .



(b) Set rf input to the AM coupling loop equivalent to a 500  $\mu\text{V}$ . Measure harmonic distortion of audio output. Maximum allowable THD is 2.0%.

## 6. 1400 kHz Measurements

With unit tuned to 1400 kHz and AM coupling loop set for 1" penetration, set rf attenuator for an input to the AM coupling loop equivalent to approx. 620  $\mu\text{V}$ . Note audio output — should be between .75 and 1.25 volts from Tape Output jacks. Attenuate rf input to 10  $\mu\text{V}$ . Check audio output which should not drop more than 3 dB from a 500  $\mu\text{V}$  input.

## 7. Calibration

(a) With AM coupling loop set for 1" penetration, set rf attenuator for an input to the AM coupling loop equivalent to a 300  $\mu\text{V}/\text{M}$  field at 600 kHz. Tune unit to 600 kHz tuning for maximum audio output. Check calibration of Dial Pointer — should read 600 kHz  $\pm$  10 kHz.

(b) Repeat above procedure for the following frequencies:

Frequency	Calibration
800 kHz	800 kHz $\pm$ 10 kHz
1000 kHz	1000 kHz $\pm$ 20 kHz
1200 kHz	1200 kHz $\pm$ 20 kHz
1400 kHz	1400 kHz $\pm$ 10 kHz
1600 kHz	1600 kHz $\pm$ 10 kHz

## 8. Final Listen AM

Using headphones plugged into the front panel phone jack and loudness control adjusted for adequate output, slowly tune across the AM dial listening for oscillations and no output indicating shorting tuning capacitor plates.

Remove shorting bar on external antenna. Connect outside antenna to unit. Check calibration using stations. Remove outside antenna, replace shorting bar and tighten screws. Turn ac power off and remove headphones from unit. Remove all test cables.

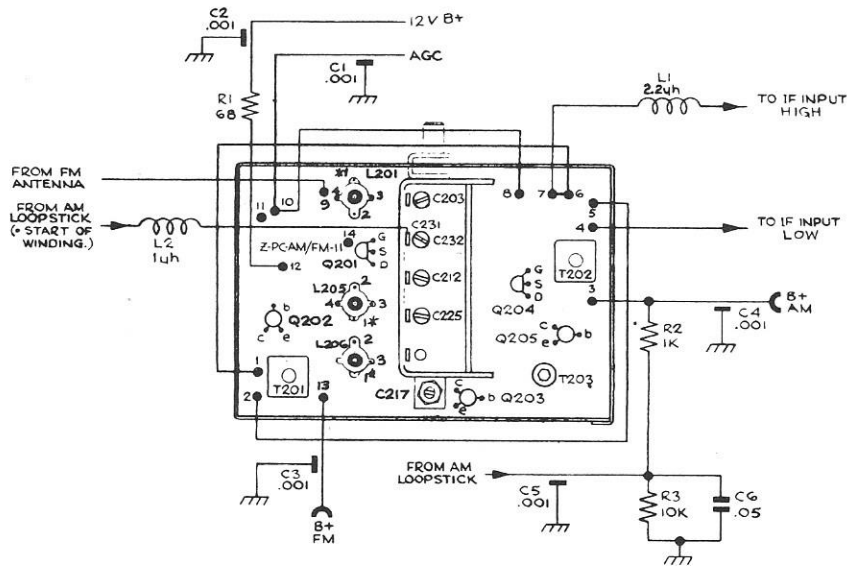

- NOTES:**
- UNLESS OTHERWISE SPECIFIED: RESISTANCE IN OHMS  $\pm 10\%$ . RESISTORS  $\frac{1}{4}$  W. CAPACITANCE IN MFD'S.
  - ARROWS INDICATE MAIN SIGNAL PATH.
  - TRIMMERS: C203 - FM ANT. } HIGH ADJ.  
C232 - AM ANT. }  
C212 - FM MIX. }  
C225 - AM OSC. }  
C217 - FM OSC. }
- COILS: L201 - FM RF. } LOW ADJ.  
L205 - FM MIX. }  
L206 - FM OSC. }
- TRANSFORMERS: T201 - FM I.F.  
T202 - AM I.F.  
T203 - AM OSC.
- TRANSISTORS AND FET'S: Q201 - FM, RF AMP.  
Q202 - FM MIX.  
Q203 - FM OSC.  
Q204 - AM, RF AMP/MIX.  
Q205 - AM OSC.
- HIGHEST SERIES NUMBERS**
- R3  
C6  
L2

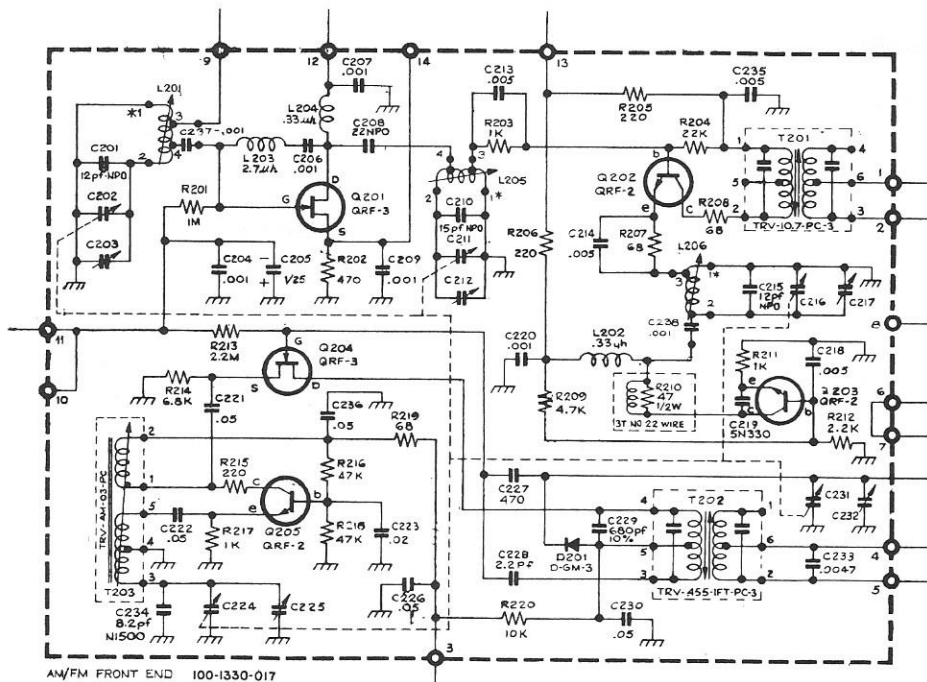
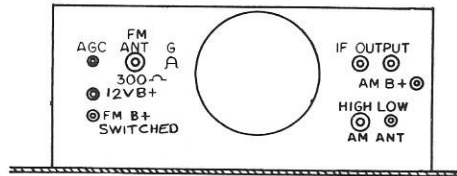

- NOTES**
- UNLESS OTHERWISE SPECIFIED: RESISTANCE IN OHMS  $\pm 10\%$ . RESISTORS  $\frac{1}{4}$  WATT. CAPACITANCE IN MFD'S. Z.X INDICATES START OF COIL WINDING.

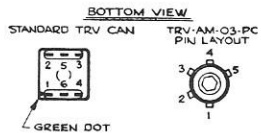
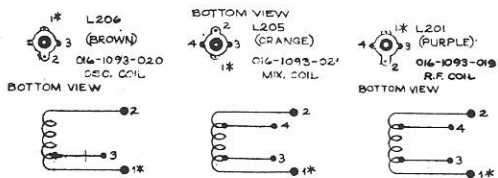

- HIGHEST SERIES NUMBERS**
- R203  
C238  
D201  
L206  
T203  
Q205

IC-301 020-1114-008  
 IC-302 020-1114-008  
 IC-303 020-1114-004  
 IC-304 020-1114-006

CIRCUIT DIAGRAM 100-1331-016 REV.2

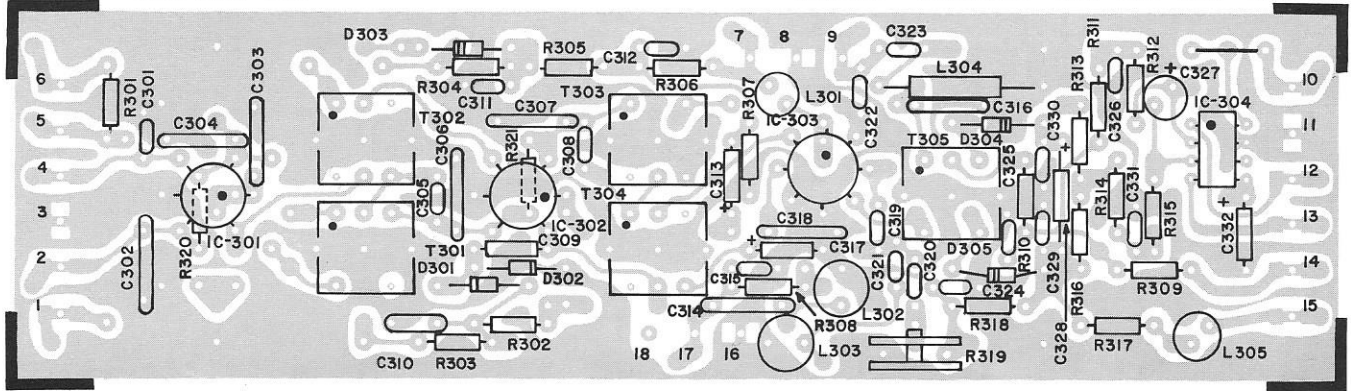

AM / FM IF

019-1107-075 Rev. 2

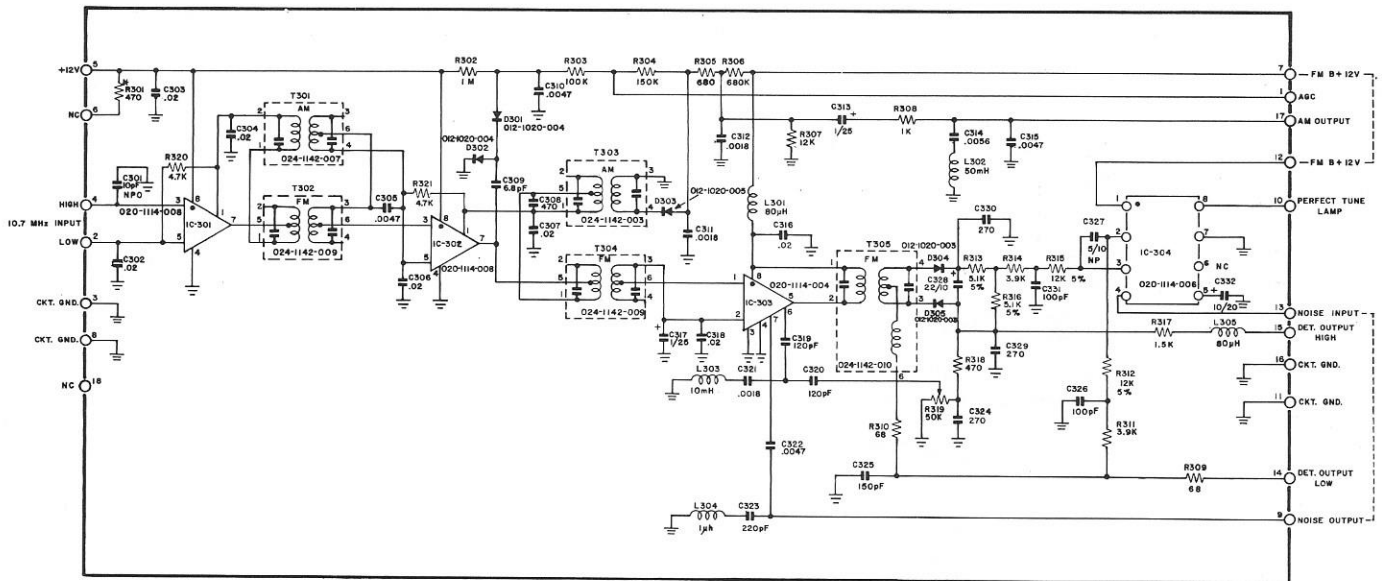

NOTES:  
 1. UNLESS OTHERWISE SPECIFIED: RESISTANCE IN OHMS ±10% 1/4 WATT,  
 AND CAPACITANCE IN MFD'S.  
 2. HIGHEST SERIES IC-304, T308, L305, D305, C332, R321.  
 3. \* PART MAY NOT BE USED IN ALL UNITS.

μA703 CIRCUIT DIAGRAM

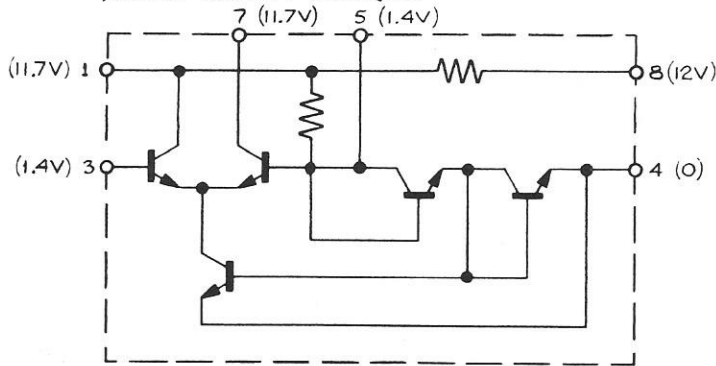

TOP VIEW

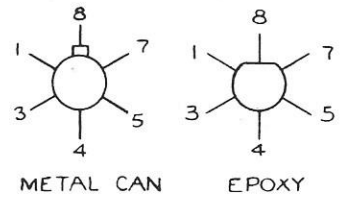

020-1114-007 LOW GAIN μA 703  
 020-1114-008 HIGH GAIN μA 703

μA719 CIRCUIT DIAGRAM

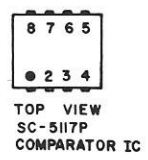
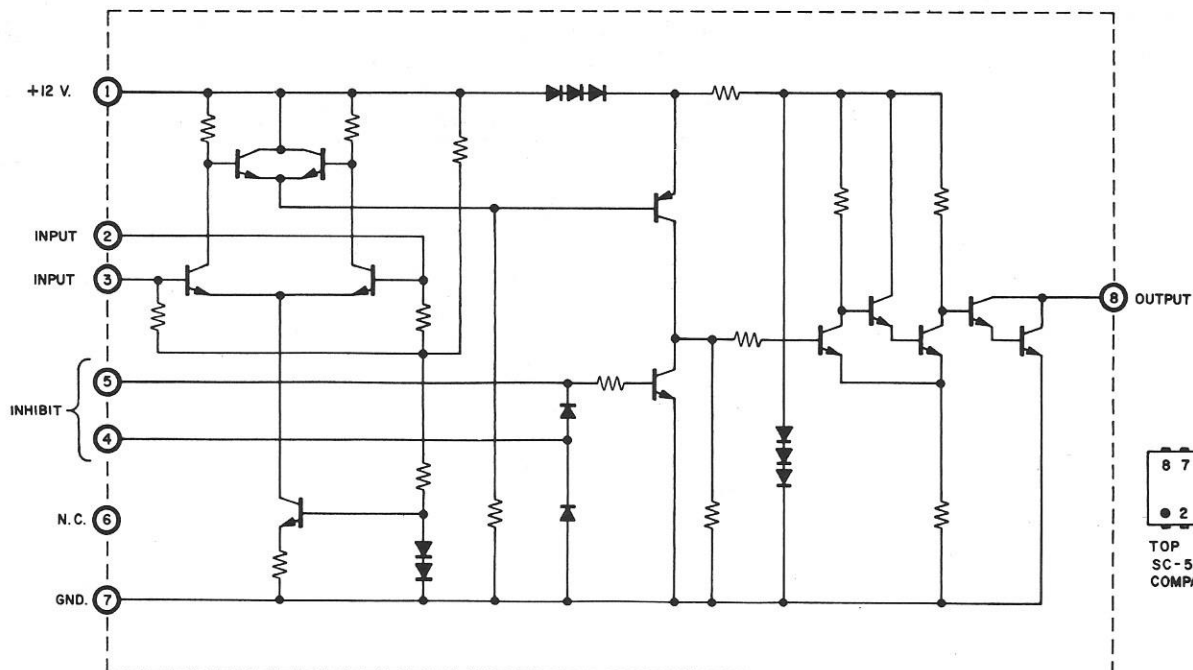
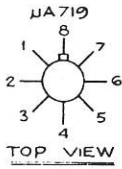
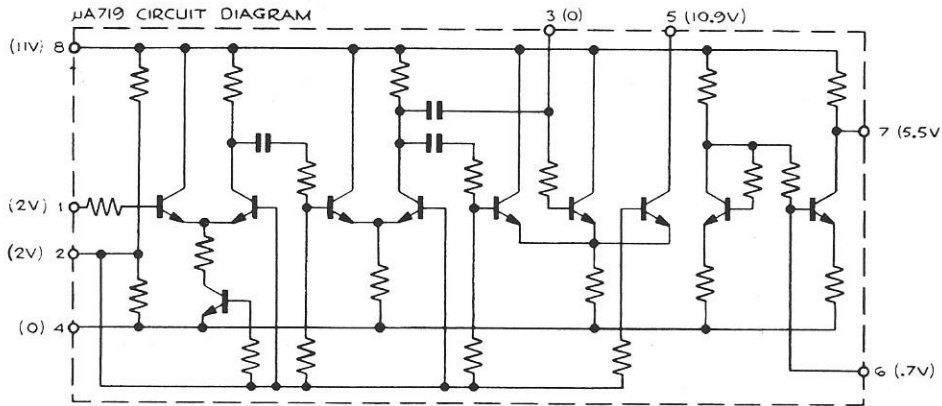

## MULTIPLEX ALIGNMENT

1. With the two pots at max in direction shown by Fig. 1, prepare to align the 67 Kc trap and the HF SEP trap. Tune to a signal modulated with 67 Kc and with a low capacity oscilloscope probe on pin 3 of IC, adjust the 67 Kc trap for minimum output. Leave probe on pin 3, tune to a stereo signal and adjust HF SEP trap for a straight base line as shown in Fig. 4.

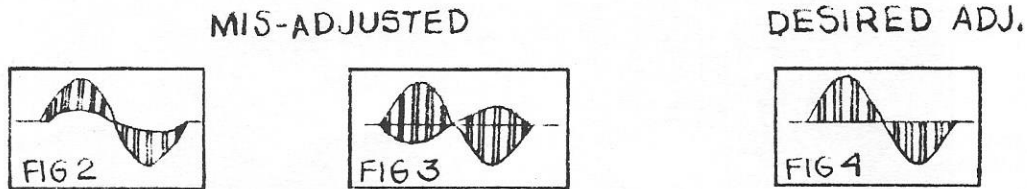

(IF THE NEXT SET OF ADJUSTMENTS ARE NOT DONE CAREFULLY, PROPER SEPARATION WILL BE DIFFICULT TO ACHIEVE)

2. Move probe to pin 1 of IC, while still on a stereo signal adjust first 19 Kc can for *maximum* output. The second 19 Kc can should also be adjusted at this point for *maximum* output.
3. Move oscilloscope probe to pin 13 and align the 38 Kc can for *maximum* output. (No alignment of the 19 Kc circuits should be done with oscilloscope probe at this point.)
4. Now that all the alignment has been completed, separation can be achieved in the usual manner by rotating the separation pot. Adjust for MAXIMUM achievable separation (absolute minimum of 30 dB).
5. Any phasing that is required must only be done by slight adjustment of the first 19 Kc can and only the first 19 Kc can.

If the 19 Kc and 38 Kc adjustments were done carefully, separation should fall within  $\pm 2$  dB between channels and going back and forth between stereo signals for readjustment should not be necessary.

6. To set stereo light, tune to either end of band, adjust pot on noise until stereo light goes off. Unit should switch to stereo on signal of 12-30 uV.

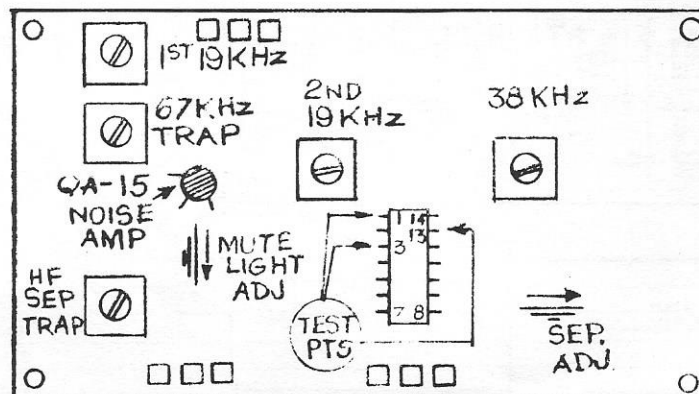

Q1, QA15, 020-1110-013  
 IC-1, 024-1114-009  
 FL-1, FL-2, 024-1144-006

CIRCUIT DIAGRAM 100-1332-006

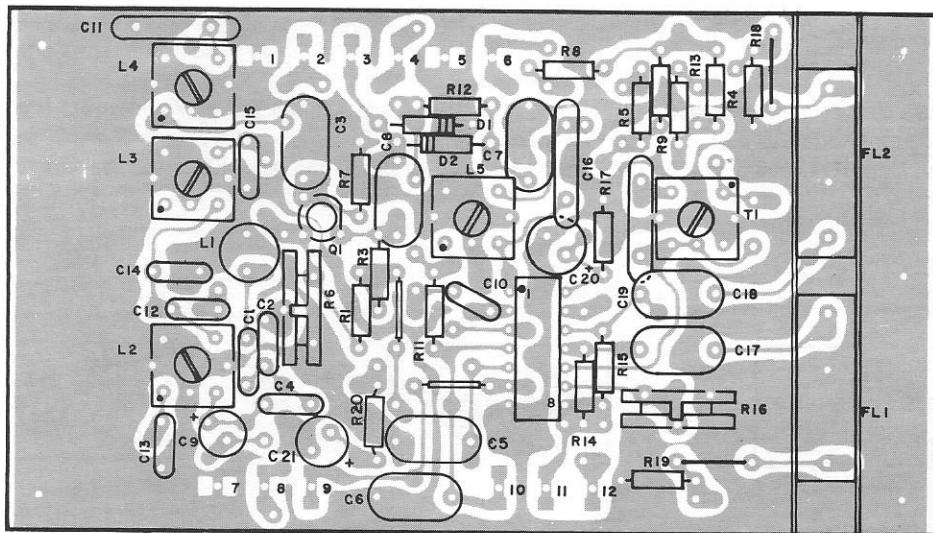

IC MULTIPLEX

NOTES

1. CIRCLE MARK ON TOP OR INDENTATION ON LEG OF IC INDICATES PIN NO.1
2. GREEN DOT ON TOP OF TRANSFORMER OR COIL CAN INDICATES PIN NO.1
3. THIS COMPONENT LABEL ARTWORK CAN NOT BE USED FOR THE PURPOSE OF SILK SCREENING A P.C. BOARD.

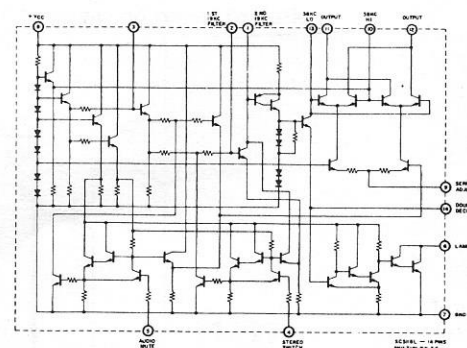
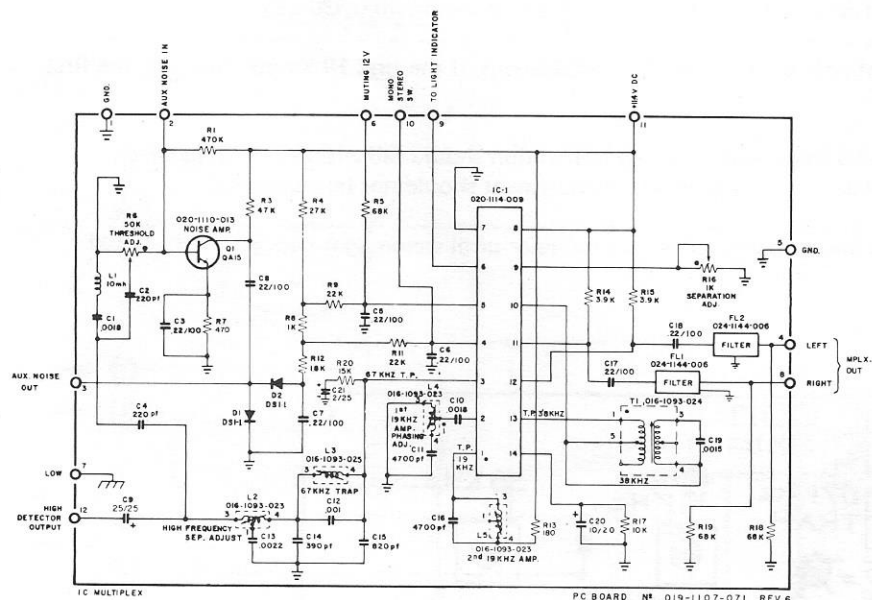

- NOTES
1. UNLESS OTHERWISE SPECIFIED: RESISTANCE IN OHMS ± 10% 1/4 WATT, AND CAPACITANCE IN MFD'S
  2. FILTER 024-1144-006 MAY BE USED IN SOME UNITS.
  3. R2 & R10 DELETED.
  4. LOWEST SERIES NUMBERS, IC1, T1, Q1, D2, L5, C21, R8, FL2
  5. CIRCLE MARK ON TOP OR INDENTATION ON LEG OF IC INDICATES PIN NO.1
  6. GREEN DOT ON TOP OF TRANSFORMER OR COIL CAN INDICATES PIN NO.1
  7. DOT OR POTENTIOMETER INDICATES EXTREME CW POSITION VIEWED FROM KNOB END
  8. ALL VOLTAGES ARE POSITIVE UNLESS OTHERWISE SPECIFIED.

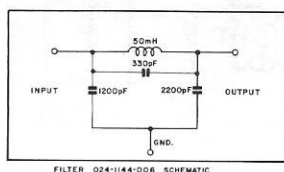

IC-1 020-1114-009

CIRCUIT VOLTAGES -HHS 2506-07- UNLESS OTHERWISE SPECIFIED;

ALL DC VOLTAGES ( $\pm 15\%$ ) MEASURED WITH RESPECT TO CHASSIS GROUND, USING  $20K\Omega/V.V.O.M.$ , AT 117VAC LINE,  $300\Omega$  LOAD ON EXTERNAL ANTENNA TERMINALS, TUNER OFF STATION AND INPUT IN "FM" POSITION.

\* VOLTAGES MEASURED UNDER SAME CONDITIONS AS ABOVE ONLY MODE SWITCH IN "STEREO" POSITION WITH STEREO SIGNAL FED INTO TUNER.

\*\* VOLTAGES MEASURED WITH INPUT SWITCH IN "AM" POSITION AND NO SIGNAL.

▲ PIN DELETED.

1. MAIN POWER SUPPLY

B+ 18 VDC  
B- 18 VDC

2. POWER SUPPLY REGULATOR - Q401

E	B	C
11.0	11.5	24

3. AM-FM FRONT END - 100-1330-017

	E	B	C		E	B	C
Q202	0.2	0.8	10.4	**	0.2	0.8	10.4
Q203	3.4	3.0	10.4		3.4	3.0	10.4
Q205	0	0	0		3.6	4.0	10.4
	GATE DRAIN SOURCE				GATE DRAIN SOURCE		
Q201	0	11.0	1.7	**	0	11.0	1.7
Q204	0	0	0		0	8.8	1.7

4. AM-FM IF AMP - 100-1331-016

	1	2	3	4	5	6	7	8
IC301	10.4	▲	1.5	0	1.5	▲	10.4	11.2
IC302	10.4	▲	1.5	0	1.5	▲	10.4	11.2
IC303	2.0	2.0	0	0	11.2	0.7	5.7	11.2
IC304	11.2	5.0	5.0	0	0	0	0	0.75/170 ON OFF

5. IC MULTIPLEX - 100-1332-006

Q1	E	B	C
	0.4	0.7	6.2

VOLTAGES DO NOT CHANGE FROM "MONO" TO "STEREO" MODE ON Q1.

IC1	1	2	3	4	5	6	7
	11.2	2.0	2.4	0.8	1.3	0.75	0
*	11.4	0.3	4.0	9.5	9.5	4.0	1.4

6. PREAMP - 100-1333-013

IC1	1	2	3	4	5	6	7
	0	7.0	4.0	4.0	0	-0.5	-8.0
	8	9	10	11	12	13	14
	-0.5	0	4.0	4.0	7.0	0	8.8

7. TONE CONTROL - 100-1334-006

	GATE	DRAIN	SOURCE
Q1	-7.0	-0.8	-9.5
Q101	-7.0	+0.2	-10.0

8. POWER AMP - 100-1349-002 (LEFT & RIGHT CHANNELS)

	E	B	C
Q301	-0.8	-1.0	-17.5
Q302	-18.0	-17.5	-0.8
Q303	-0.25	0.3	18.0
Q304	-0.25	-0.8	-18.0
Q305	18.0	18.0	0.25
Q306	-18.0	-17.5	-0.25

BIAS CURRENT

BIAS CURRENT OF THE POWER AMP P.C. BOARD SHALL BE MEASURED AS FOLLOWS:

V.O.M. SET TO MEASURE D.C. CURRENT.

MINUS OR COMMON PROBE OF V.O.M. TO COLLECTOR OF Q306 AND POSITIVE PROBE TO COLLECTOR OF Q305.

READ 1.2mA ( $\pm 5\%$ ), NO SIGNAL PRESENT.

D.C. OFFSET VOLTAGE

WITH NO SIGNAL APPLIED, READ 0 VOLTS  $\pm 150$  mV AT SPEAKER OUTPUT JACK, WITH RESPECT TO CHASSIS.

A.G.C. VOLTAGE (FRONT END A.G.C. TERMINAL)

+0.1V TO -0.75V WITH 0 TO 100  $\mu$ V SIGNAL FED INTO  $300\Omega$  EXTERNAL FM ANTENNA.

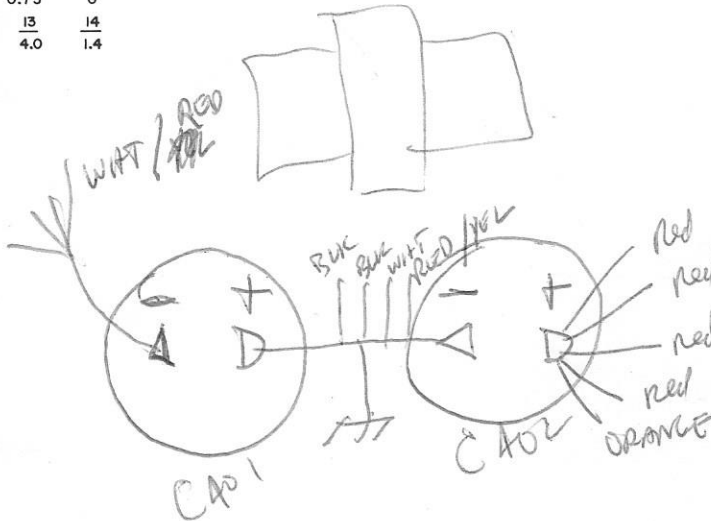

INPUT SELECTOR SW. POSITION INDICATES FULL CCW

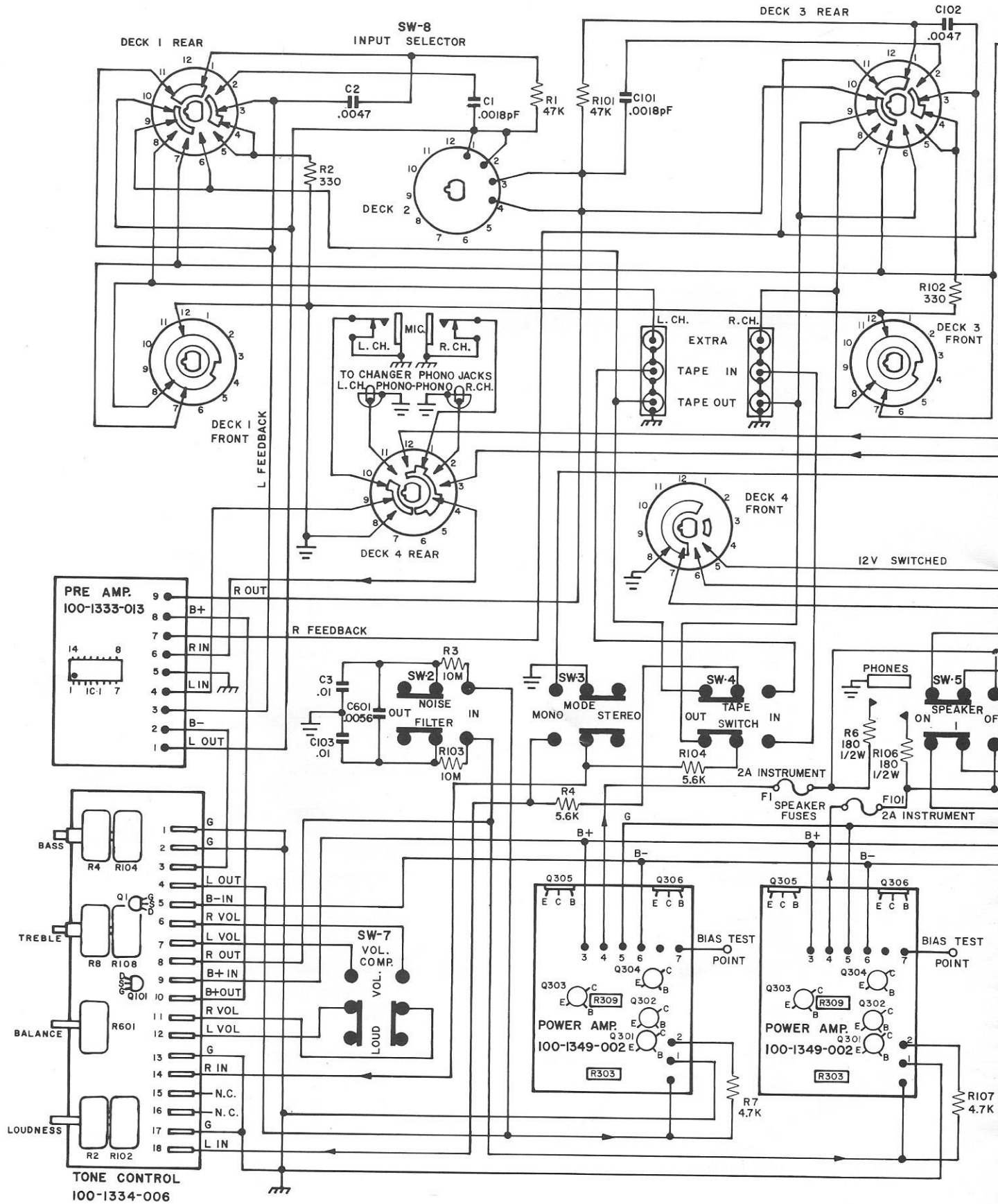



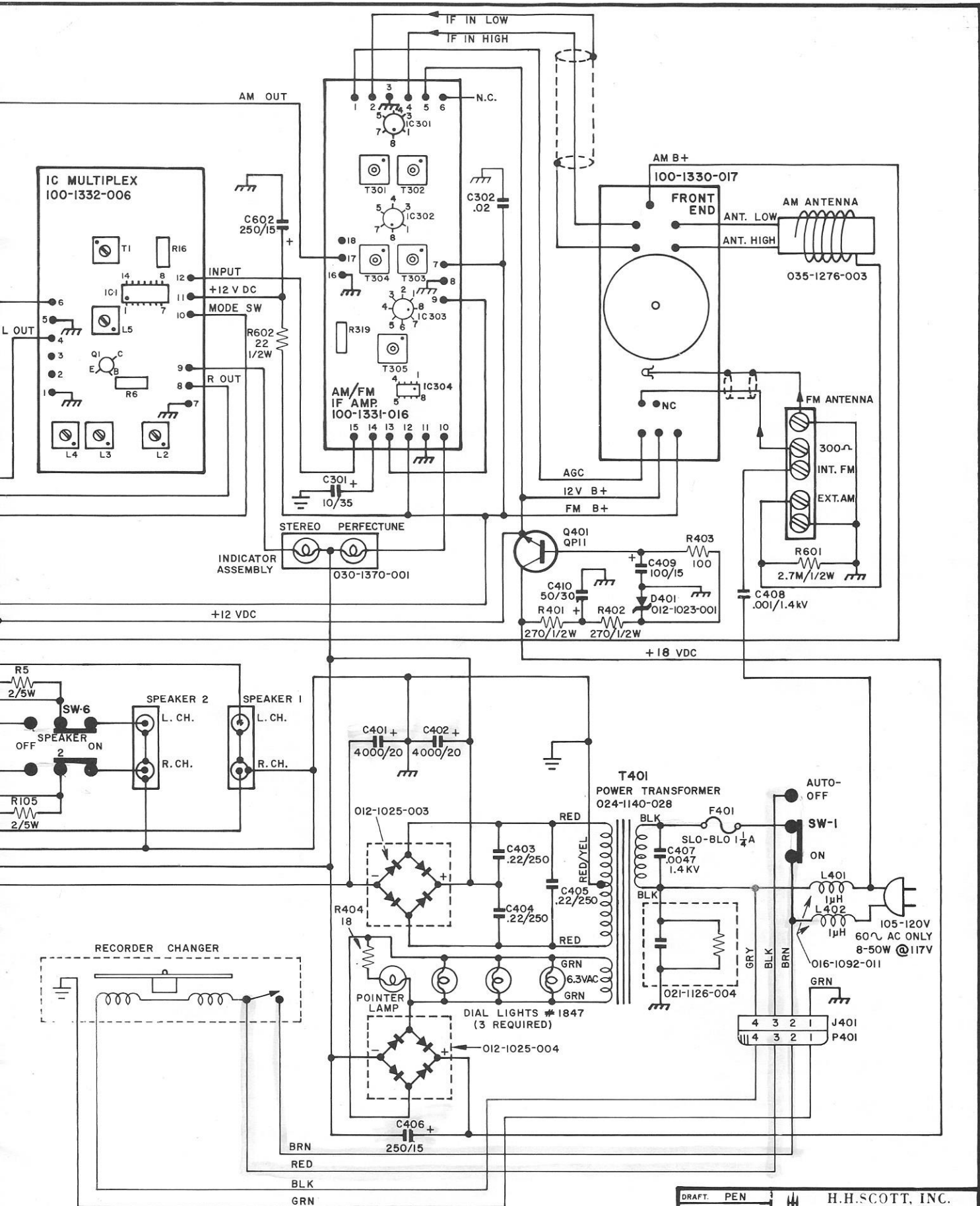

DRAFT: PEN	3	H.H. SCOTT, INC. MAYNARD, MASS.
CH.		
ENG. <i>[Signature]</i>		CIRCUIT DIAGRAM
SHEET 1 OF 2	SIZE D	
DATE 8-14-69	DWG NO. 2506-07-C1	REV 1

QTY. PER UNIT	PART NUMBER	OLD PART NUMBER	DESCRIPTION
2	011-1000-006	CC-.0018	Ceramic Capacitor .0018 mfd 500v
2	011-1000-010	CC-.0047	" " .0047 mfd 500v
1	011-1000-011	CC-.0047/1.4KV	" " .0047 mfd 1.4 KV
1	011-1000-012	CC-.0056	" " .0056 mfd 500v
2	011-1000-017	CC-.01-20%	" " .01 mfd 500v
1	011-1000-018	CC-02	" " .02 mfd 500v
1	011-1000-060	CC-.001/1.4KV	" " .001 mfd 1.4KV
2	011-1004-025		Elect. Capacitor, Can 400 mfd 20v
2	011-1006-052	CETM-250/15	Elect. Capacitor, Tub. 250 mfd 15v
1	011-1006-024	CETM-10/15	" " 10 mfd 15v
1	011-1006-037	CETM-100/15	" " 100 mfd 15v
1	011-1006-019	CETM-50/75	" " 50 mfd 75v
3	011-1008-008	CMM-.22/250	Molded Mylar Capacitor .22 mfd 250v
1	012-1023-001	DZ-12	Zener Diode
1	012-1025-003		Bridge Rectifier 2 amps 100v
1	012-1025-004		" " 150 m.a. 15v
4	013-1030-002	F-AGX-2	Fuse
1	013-1031-007	F-SB-1¼	Fuse, Slo-Blo
1	015-1060-003	J-2-Q	Input Jack
2	015-1060-005	J-2-T	" "
1	015-1061-007	J-3-ST-8	Phone Jack
2	015-1061-008	J-8-M	Min. Phone Jack
2	016-1092-011	L-RF-1S	Coils (Consists of 54 1/8" of WM-22 & 1½" IT-S4 Tubing)
3	018-1100-032		Single Knob
2	018-1100-033		Rear Knob
2	018-1100-034		Front Knob
1	018-1100-037		Tuning Knob
7	018-1100-038		Push Button Knobs
1	018-1102-095		Front Panel
1	018-1104-016		Panel Inlay
1	018-1105-070		AM/FM Dial
1	020-1111-003	QP-11	Power Transistor
2	021-1123-046	RW5-2	Wirewound Resistor 5W 2 ohms
1	021-1126-004		Package Res./CC
1	023-1137-033	SRW-125-2	Rotary Switch
1	023-1138-013		7 Sect. Pushbutton Switch

QTY. PER UNIT	PART NUMBER	OLD PART NUMBER	DESCRIPTION
1	024-1140-028		Power Transformer
1	026-1152-004	WP-6xT-1	Line Cord
1	027-1162-007		Cabinet W/1-032-1250-244 & 1-032-1250-244
1	028-1165-		Carton
1			Cacoon
1			Filler – Changer Hold-down
1	028-1167-019	CTF-51	Avis Strap
1	028-1167-020	CTF-52	Buckle
2	028-1169-001	CTF-16	Staples
10	028-1169-002	CTF-24	"
3	030-1189-008	V-PL-1847	Bulb
3	030-1190-012	X-PL-U10	Socket
1	030-1192-001	XF-3AG	Fuse Post W/nut & washer
2	030-1192-002	XF-HJM	" " "
1	030-1193-001	X-Q-3	Transistor Socket
1	030-1194-001	X-AC-MR	AC Molded Receptacle
1	030-1285-003	I-J-2-Q	Jack Insulator
2	030-1285-004	I-J-2-T	" "
1	030-1370-001		Indicator Assy.
1	031-1197-026		Dial Cord
1	031-1198-014		Dial Pointer Assy. (Includes 1-030-1189-015 5 volt, 60 m.a. bulb)
1	031-1274-005	PL-480-134-1	Changer Plug
1	031-1328-005		Cord Drive
1	032-1251-091	Z-AM/FM-11-M2	Top Cover (Front End)
1	032-1251-106	NEW	Bottom Cover
1	032-1251-115	NEW	Dust Cover (Separate Parts List on the Dust Cover) .2589 P/L
1	032-1252-101	NEW	Front Chassis
1	032-1252-102	NEW	Main Chassis
1	032-1256-010	NEW	Dial Pointer Track
1	032-1258-001		Bushing Plate
1	033-1260-012	NEW	Changer (Includes 1 Pickering Cartridge V15/AT-S-033-1262-009)

QTY. PER UNIT	PART NUMBER	OLD PART NUMBER	DESCRIPTION
1	034-1271-017	NP-148	Nameplate
1	035-1276-010	Z-ANT-AM-12	AM Antenna
1	100-1330-017		Front End Assy.
1	100-1331-016	NEW	AM/FM IF Board Assy.
1	100-1332-006	NEW	IC Multiplex Board Assy.
1	100-1333-013		Pre-amp Board Assy.
1	100-1334-006	NEW	Tone Control Board Assy.
2	100-1349-002	NEW	Driver/Power Board Assy.
			DELETE:
1	024-1140-028		Transformer
1	030-1188-009	TS-3A	3 Pin Terminal
1	030-1188-010	TS-3B	3 Pin Terminal
1	Model 715		Changer W/60Hz Pulley (Garrard Pt. # 58921)
			ADD:
1	024-1140-038		Transformer
2	030-1188-013	TS-4A	4 Pin Terminal
1	023-1135-004	SS-22-0	Slide Switch
1	Model 715		Changer W/50Hz Pulley (Garrard Pt. #58920)
1	013-1031-005	F-SB-.7/250	Fuse

Scott . . . where innovation is a tradition



H. H. Scott, Inc. 111 Powdermill Road, Maynard, Mass., 01754