

H. H. SCOTT, INC.  
111 Powder Mill Road  
Maynard, Mass.

SERVICE BULLETIN

For

MODEL 310D BROADCAST MONITOR FM TUNER

SPECIFICATIONS

(These specifications are minimum - all H. H. Scott 310D tuners must meet or exceed these figures).

Usable Sensitivity (IHFM) (For less than 3% Total Noise, distortion, hum -30 db)	2.0 microvolts
Signal to Noise Ratio	60 db below 100% modulation
Total Harmonic Distortion	0.5 %
Frequency Deviation	0.02 %
Frequency Response	20-20,000 cps $\pm$ 1 db
Capture Ratio	2.2 db
Selectivity	50 db
Spurious Response Rejection	85 db
Hum	66 db
AM Suppression	60 db
Audio Output (100% modulation)	4 - 6 volts
Tuning Range	87-109 mc
Accuracy of Calibration	0.5 %
Output Impedance	3000 ohms
Minimum Recommended Load Resistance	100,000 ohms
Minimum Recommended Cable Capacitance	1000 mmfds
Maximum Recommended Length of Output Lead	70 feet
Range of Line Voltage and Frequency	105-125 volt 50/60 cps
Power Consumption - AC ONLY - <u>DO NOT OPERATE</u> <u>WITH DIRECT</u> <u>CURRENT</u>	50 watts

GENERAL SERVICE NOTES

Service, other than replacement of either pilot lights or vacuum tubes is usually not required. If the tuner is not operating properly, all external connections should be checked to make sure that the difficulty is in the tuner. Generally, it is advisable to replace the connection to the tuner with a tape recorder or similar device to check out the amplifier performance. If the difficulty appears to be located in the tuner, the level control should be first checked, to insure that it is rotated away from its extreme counter-clockwise position. Then, the vacuum tubes should be checked by replacing them with new ones, one by one. The tubes should be tight in their sockets and provided with shields where applicable. Tube defects frequently do not show up in a tube tester. Only operation in the tuner will insure the proper working of a vacuum tube.

Part No. D-310D-2

The pilot light may be simply replaced by the following procedure:

1. First set the tuning dial so that the heavy white lines line up with the pointers on the dial and the logging scale is towards the top of the panel. In this position, the tuning condensers are closed.
2. Unscrew and remove the tuning knob and dial. This will permit access to the pilot light which is a #47 bulb.

After the bulb has been replaced, use the following procedure:

1. Close the condenser plates by rotating the condenser to the extreme counter-clockwise position.
2. Replace the dial, lining up the heavy white lines of the dial with the pointers and keeping the logging scale toward the top of the front panel.
3. Replace the tuning knob.

#### ALIGNMENT INSTRUCTIONS

Note: No attempt should be made to align the tuner or repair it unless the person so doing has had extensive experience in tuner alignment and repair procedures and has the necessary laboratory equipment. Without proper experience or equipment, the repairman may seriously damage the tuner.

1. Equipment required: VTVM (AC), FM Signal Generator (must be of high quality), Oscilloscope, 400 cps null filter or distortion analyzer, and insulated alignment tools.
2. Equipment setup: Connect signal generator directly to the 300 ohm antenna input of the tuner using a matching impedance network if necessary. The audio output of the 310D then feeds into the 400 cps null and from the null to the oscilloscope and VTVM in parallel. If no null is available (a schematic for making one of these very simple and useful devices is available from the Engineering Dept.), the tuner can still be serviced. However, it will not be possible to measure the tuner's "Usable Sensitivity" as per IHFM standards, or align the detector.
3. Allow tuner and test equipment to warm up fully before beginning alignment. Adjust line voltage for 117 volts. Remove bottom cover of tuner. Always tune primary and secondary of I.F. transformers at the same time, using one alignment tool in each hand.
4. Set generator and tuner for 92 mc. Generator should be modulating a 400 cps signal at 75 kc deviation. Adjust output of generator so that a barely adequate sine wave appears on the scope (on the order of 2 to 4 microvolts input to tuner). The null filter should be switched out of the setup, so the tuner is feeding directly to the VTVM and scope. Peak the IF's and the primary of the ratio detector (the bottom slug) for maximum reading on the VTVM.
5. Adjust the secondary of the ratio detector (top slug) for maximum reading on VTVM and cleanest response on the scope. There will be more than one maximum point, but only one will be "clean" on the scope.
6. Return generator output back down to 2 to 4 microvolts. Adjust antenna coil for maximum output. Tune generator and tuner to 106 mc. with same output and deviation, and adjust antenna trimmer for maximum output. Repeat this operation until best results are obtained.
7. If calibration is off, repeat "6" except adjust oscillator coils for correct tracking at 92 mc. and oscillator trimmer for correct tracking at 106 mc.

3. Squelch (interstation noise suppressor) adjustment: Turn tuning dial off station so that regular interstation hiss is audible. Set front panel Noise Suppressor control to "3". Adjust DINS level on top rear of chassis so that relay clicks in.

MISCELLANEOUS SERVICE PROCEDURES AND TESTS - (Qualified technicians only)

Note: Replace bottom plate before testing.

1. Test for IHFM Usable Sensitivity measurements: Use 117 volt regulated line, set generator and tuner at 92 mc. with 4 microvolt input. This test is performed at each of the standard test frequencies with the signal generator connected to the tuner under test through the standard 300 ohm dummy antenna. The signal generator should be frequency modulated with standard test modulation. The controls of the tuner shall be set to the normal control settings. The signal intensity should then be reduced to the least value which will produce a 30 decibel rise in indicated output with standard test modulation as compared with the indicated output with standard test modulation measured through a 400 cps null filter. This test serves to indicate the relative freedom of the tuner from objectionable internal receiver noise during pauses in modulation when receiver noise is least likely to be masked by modulation. This test also serves to indicate the relative freedom of the tuner from objectionable distortion during periods of maximum modulation.
2. Audio output: With 1000 microvolt input, 75 kc deviation, maximum output should be 4-6 volts.
3. Automatic Gain Control: The maximum permissible difference in output between an input of 3 microvolts and 1000 microvolts is 3 db.
4. FM Hum: At 100 mc., 1000 microvolts input, 400 cycle modulation, take a reference reading the remove modulation. A 50 db drop should be noted. Have level control at maximum.
5. AC Hum: As above but with no modulation and level control at minimum. Hum should not exceed .002 volts.
6. Oscillation Check: Check entire FM band for oscillation, with and without antenna, at 105 and 130 volt line.

If any of the above tests are not met, then the unit should be carefully tested for alignment, tube weakness, or component failure. All H. H. Scott tuners are carefully tested before leaving the factory so that they will exceed the published specifications. There is no reason why they should not continue to perform that way for a long time, or why they cannot be brought back to this condition if service is necessary.

IMPORTANT:

Unless proper precision test and service equipment is used, it will be impossible to properly service or test the tuner.

If there are any questions or problems, write to:

Technical Services Dept.  
H. H. Scott, Inc.  
111 Powder Mill Road  
Maynard, Massachusetts

H. H. SCOTT 310D BROADCAST MONITOR TUNER COMPONENT LAYOUT

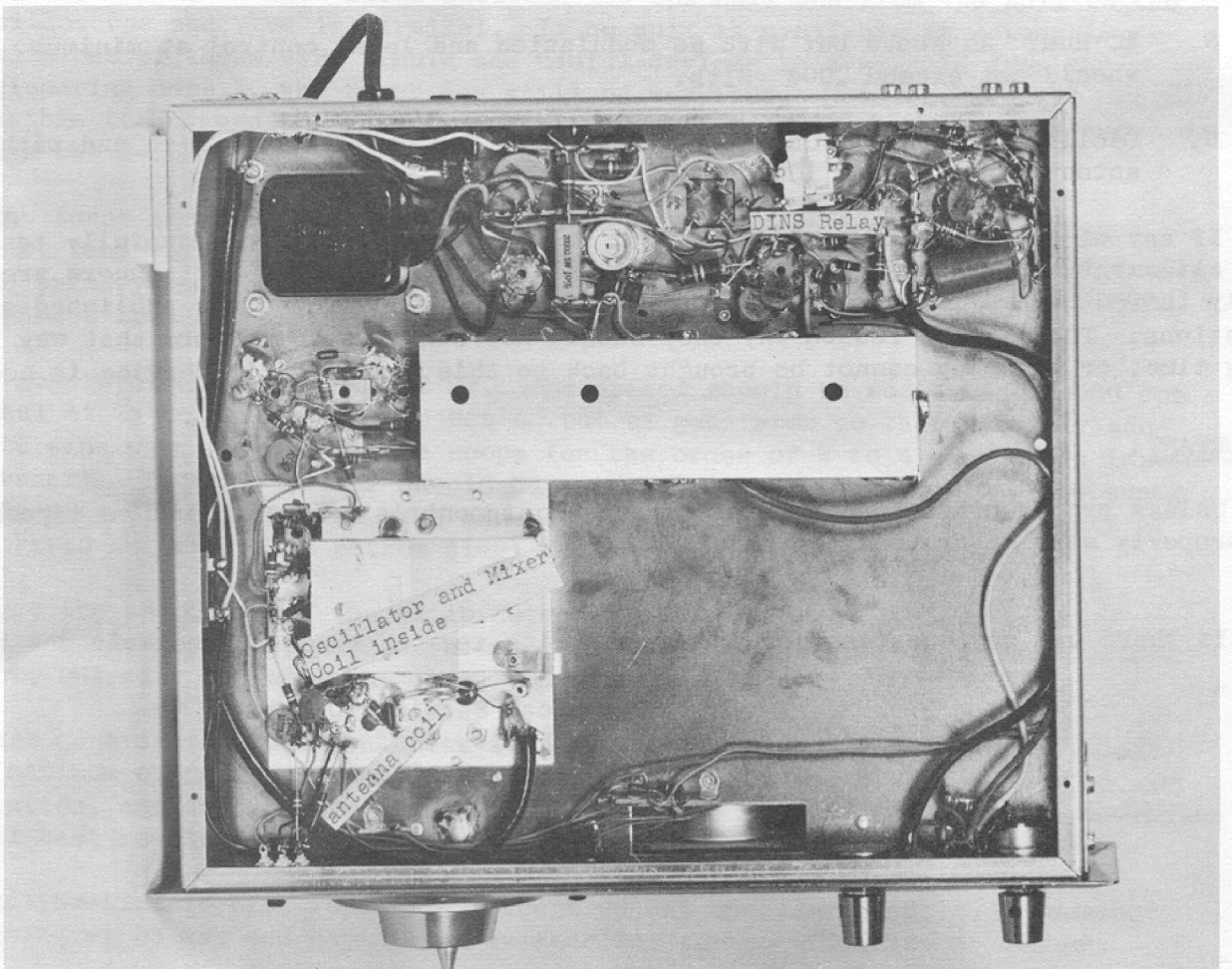
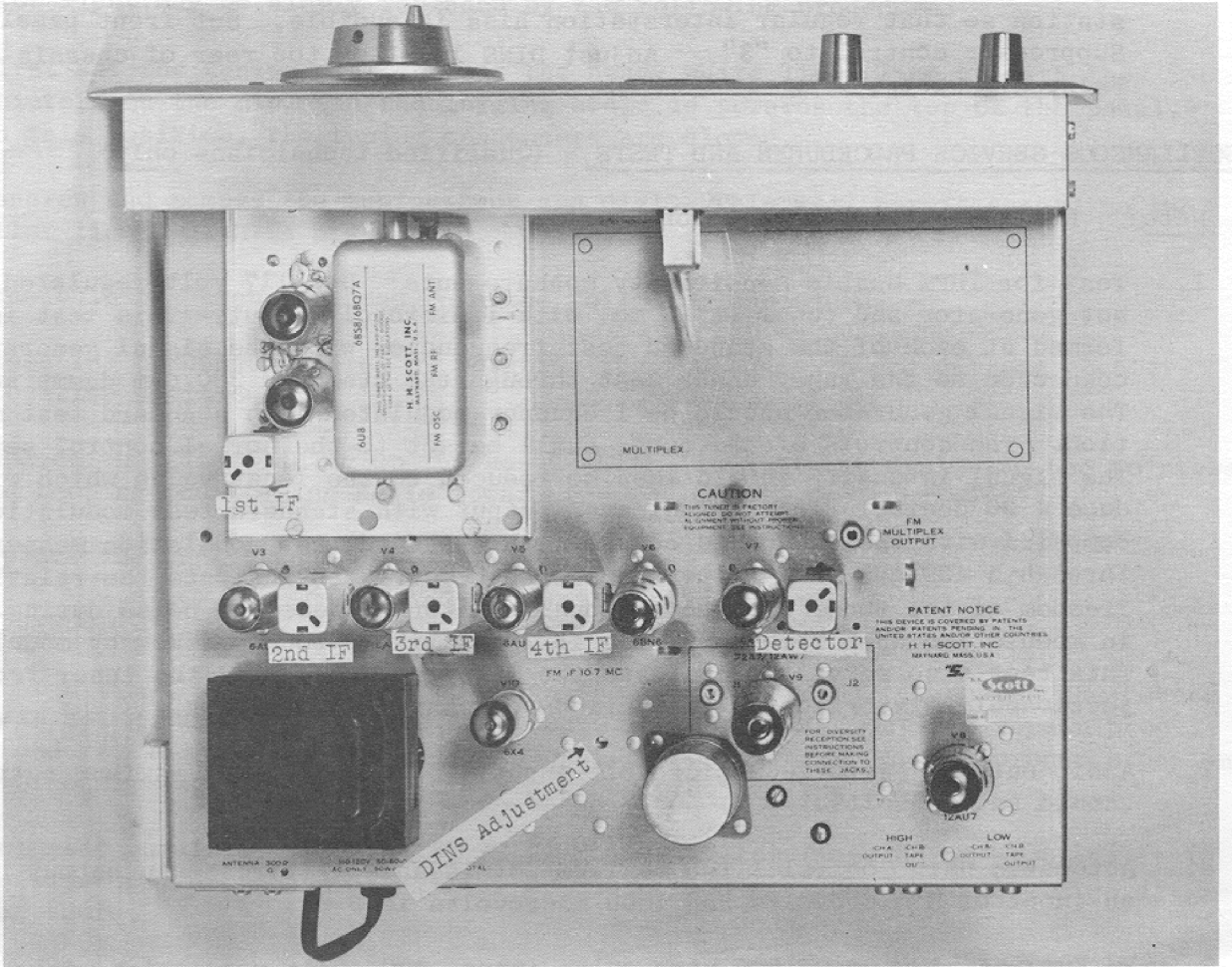

6B5B/6BQ7A

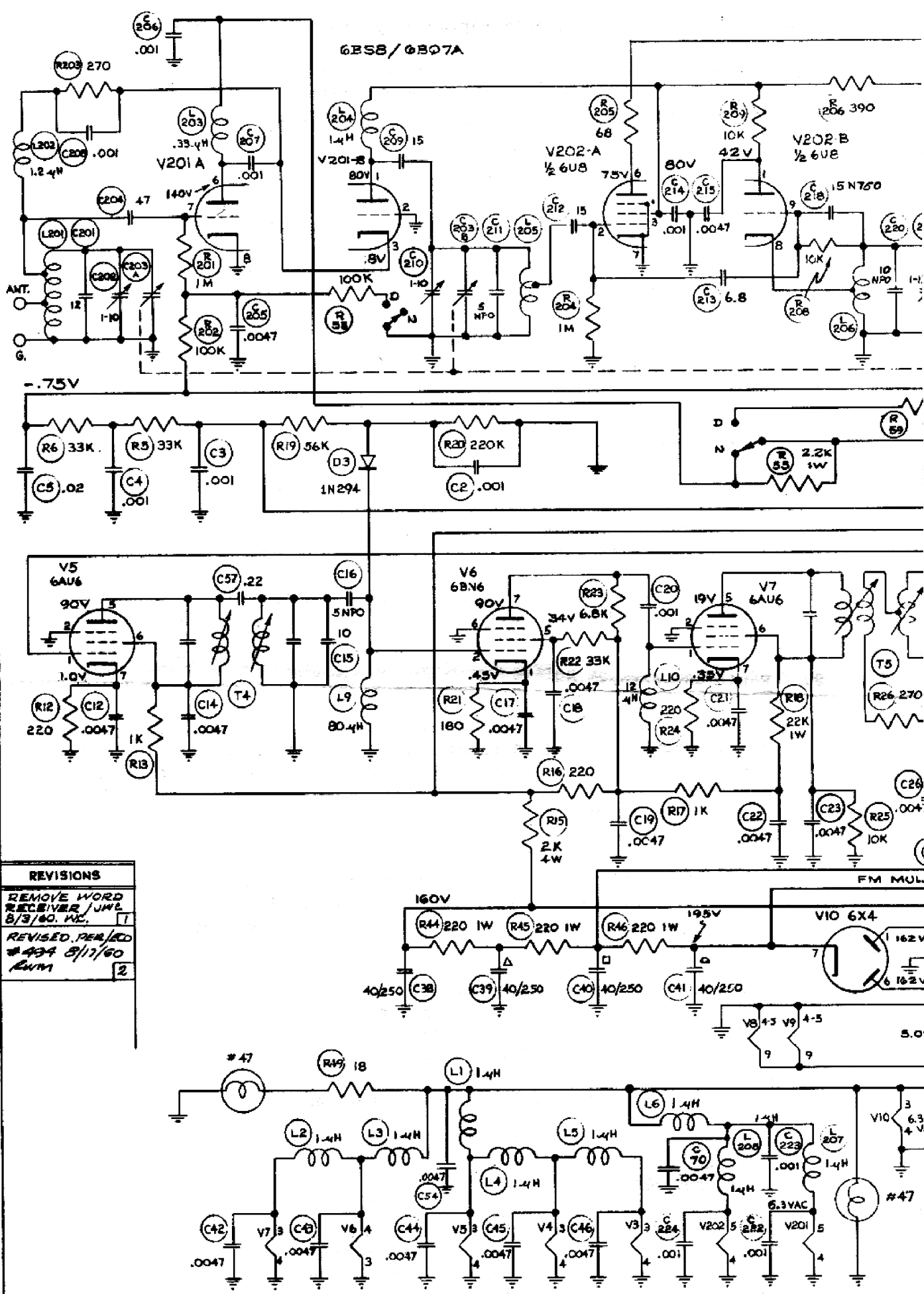

REVISIONS	
REMOVE WORD RECEIVER/JWL 8/3/60. KC.	1
REVISED PER/EDD #434 8/11/60 RWV	2

HIGHEST R R73  
HIGHEST C C70

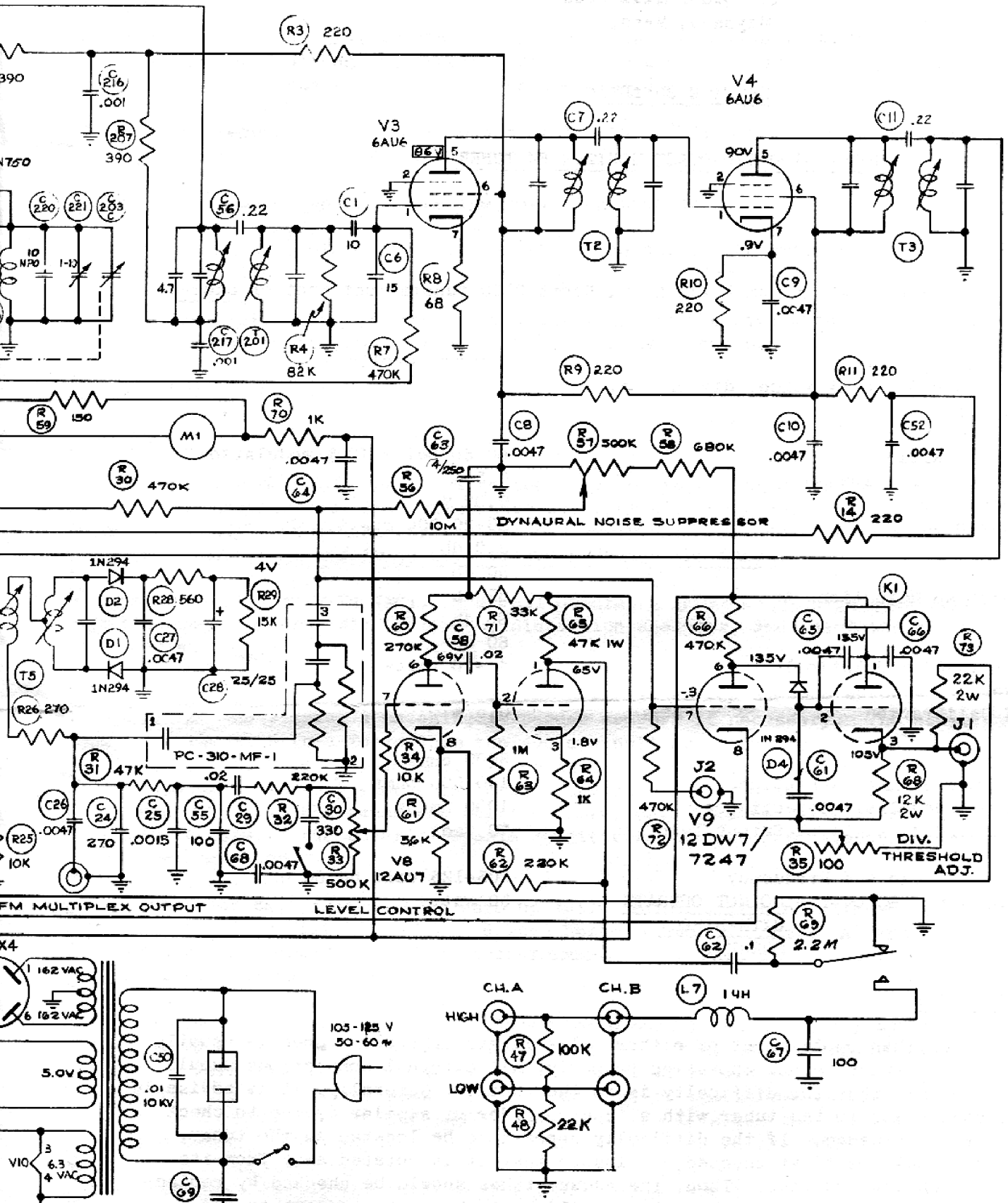

VOLTAGES MEASURED WITH V.T.V.M NOISE SUPPRESSOR POT AT MAX. C.C.W AND TUNED OFF STATION WIT 300.Ω LOAD ON ANT. TERMINALS & 117V LINE. *SWITCH IN NORM. DIST.-NORM.*

UNLESS OTHERWISE SPECIFIED  
 ALL DIMENSIONS ARE IN INCHES  
 TOLERANCE ON FRACTIONAL DIMENSIONS = 1/64  
 TOLERANCE ON DECIMAL DIMENSIONS = .005  
 TOLERANCE ON ANGULAR DIMENSIONS = 1/2°  
 BREAK SHARP CORNERS.

SCALE:	5/10/60.
310D CIRCUIT DIAGRAM	
HERMON HOSMER SCOTT, INC. CAMBRIDGE, MASS., U.S.A.	
DR: DYSZCZYK/AC	ENG:
CH: DFM	PROD:
DWG. NO. C-310D-C1 SUB 2	