

SCOTT 325R/335R

FM IF Amplifier

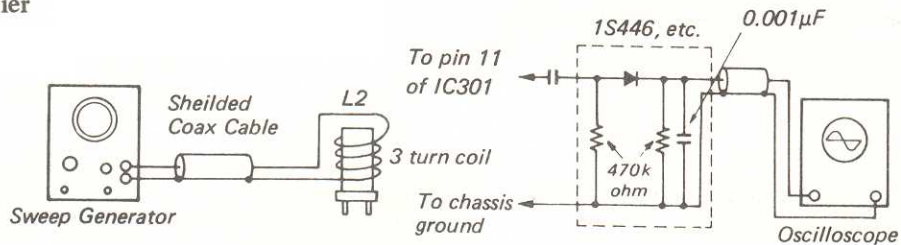

- 1) Mute the FM local oscillator by shorting L4.
- 2) Connect the oscilloscope to pin 11 of IC301.
- 3) Apply 10.7 MHz signal from the sweep generator to L2 in the manner as shown above.
- 4) Adjust L201 for correct figure as shown. It may be necessary to increase or decrease the sweep generator output for adjustment convenience.



Correct

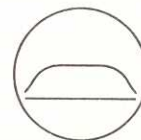

Incorrect,
as too low



Incorrect,
as too narrow

FM RF Tracking

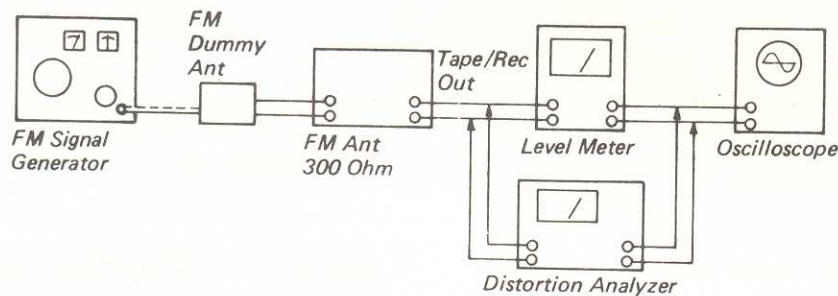

- 1) Apply 90 MHz, 1 kHz and 100% modulated, 25 dBf signal level to the FM antenna terminals.
- 2) Tune the unit to 90 MHz.
- 3) Observe the oscilloscope connected to the Tape/Rec output terminal for symmetrical sine wave. If failed, adjust L4.
- 4) Adjust L1 and L2 for maximum level meter reading. Reduce input from the 25 dBf level as necessary to maintain noise on sine wave.
- 5) Readjust the signal generator for 106 MHz, and retune unit.
- 6) Repeat step 3. If failed, adjust the OSC. trimming capacitor mounted on the tuning capacitor.
- 7) Adjust the trimming capacitors, for mixer and RF.
- 8) Repeat as necessary until product specifications are met.

Center Tuning Indicator (LED Pointer Assy.)

Connect DMM (switched to DC volts) between chassis and pin 15 of IC201. Tune receiver to signal generator with output level set at 65 dBf. Carefully tune for lowest AGC voltage (approx. 2.5).

FM Distortion

With unit connected as above for tuning indicator adjustment, adjust T203 for minimum harmonic distortion.

FM Signal Strength Display

- 1) At 98 MHz, with receiver connected and tuned to FM generator, apply 65 dBf signal to unit antenna.
- 2) Adjust R217 until all five LEDs are lighted.

Mute Threshold Adjust

- 1) At 98 MHz, 20 dBf signal level, and set-up connected as above, tune unit with mute switch in the OFF position.

Multiplex Pilot Adjust

- 1) Apply 98 MHz, 65 dBf signal to the unit with no modulation.

Stereo Separation

- 1) Apply 98 MHz, 65 dBf left channel signal to the unit modulated with 1 kHz, 9% pilot signal.
- 2) Connect a digital voltmeter to the right channel Tape/Rec output terminal.
- 3) Adjust R315 for minimum leakage (minimum level) on the voltmeter.

AM IF Amplifier

- 1) Apply 455 kHz sweep generator output to the unit AM antenna terminal.
- 2) Connect scope to pin number 12 of IC3.
- 3) Adjust T8 to obtain maximum and symmetrical display as shown.

AM Tracking

- 1) Apply 600 kHz, 30% modulated with 1 kHz to the AM bar antenna. See test setup figure. (Distance between the AM bar antenna and emitting loop antenna should be 2 feet.)
- 2) Adjust signal generator output so that a sine wave appears on the scope.

Reconnect DMM to terminals 603 and 604 on display board 3014-513-8108. Adjust T202 for zero volts on DMM.

Since there is some interaction between coil settings repeat center-tune and distortion adjustments for optimum results.

- 3) Reduce RF generator output to minimum, tune receiver off station and adjust R621 on display board until both green LEDs in pointer assembly are turned ON and all signal strength LEDs are turned OFF.

NOTE: R217 replaced with fixed resistor in some production units.

- 2) Switch MUTE ON and adjust R220 until FM output is muted.

- 2) Adjust R317 for 76 kHz reading on the frequency counter connected between TP and chassis ground. A deviation of +200 Hz is acceptable.

- 4) Apply 98 MHz, 65 dBf right channel signal to the unit modulated same as step 1.
- 5) Move digital voltmeter to the left channel Tape/Rec output terminal.
- 6) Check for approximately the same leakage as in step 3.



- 3) Adjust L102 for maximum audio output on the digital voltmeter connected parallel with the scope. When turning core, always adjust signal generator output to maintain low input level. Do not change voltmeter range. Moreover, always keep the generator output as low as possible to avoid

SCOTT 325R/335R

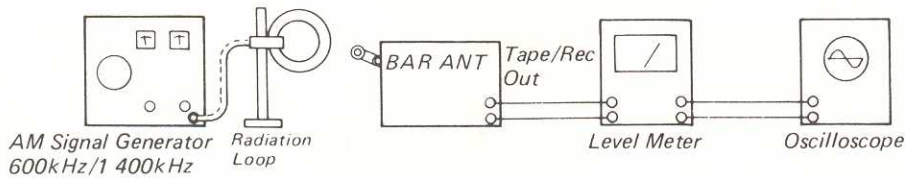

- AGC action and to keep the measurements accurate.
- Adjust the AM loopstick antenna core for maximum output reading on the voltmeter.
 - Shift generator frequency to 1,400 kHz with same modulation condition.
 - Repeat step 2.
 - Adjust OSC. trimmer for maximum voltmeter reading.
 - Adjust Ant. trimmer for maximum reading on the voltmeter.
 - Repeat items 3 through 8 for best tracking and maximum sensitivity.

Audio Adjustments

Equipment Required

Audio signal generator.
Digital multimeter.
Speaker load resistors, 8 ohm 100 watt.

The following adjustments are the same for both the left and right channels.

Bias Adjustment

- Connect 8 ohm load resistors to the Speaker A terminals, and set the Speaker A switch to ON position.
- Turn the Volume control fully counterclockwise.
- Turn R1412 fully counterclockwise.
- Using digital multimeter set meter to read 200 mV. Connect probes across R1423 and R1424 (Voltmeter bias test points, L channel). Turn unit ON. Let it idle for at least one minute. Adjust R1412 for 20 mV across the resistors.
- Perform the same procedure for the right channel, except measure voltage across R1473 and R1474 (voltmeter bias test). Adjustment is made with R1462.
- Leave the amplifier on for about 30 minutes, then recheck measurement. A tolerance of $\pm 25\%$ is acceptable. Readjust if necessary.

Power Indicator Adjust

- With 8 ohm speaker loads connected, increase output until 15.5V are measured across output loads.
- Adjust R803 and R853 until all green LEDs are ON.
- Increase output level and note red LEDs switch ON.

Dial Cord Stringing

- Loosen the screw securing the drum to the variable capacitor shaft.
- Tie the end of the cord "A" as shown to the fixing protrusion on the drum.
- Wind the cord two turns around the drum then thread it through the rollers, etc., following the illustration.
- Tie the end of the cord to the coiled spring so that the proper tension of the dial cord is obtained.
- Align the pointer position for the correct frequency indication on the tuning dial.
- Secure the screw on the drum.

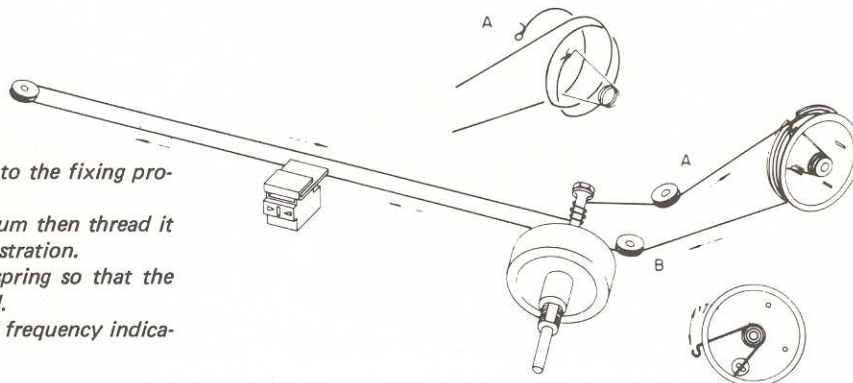

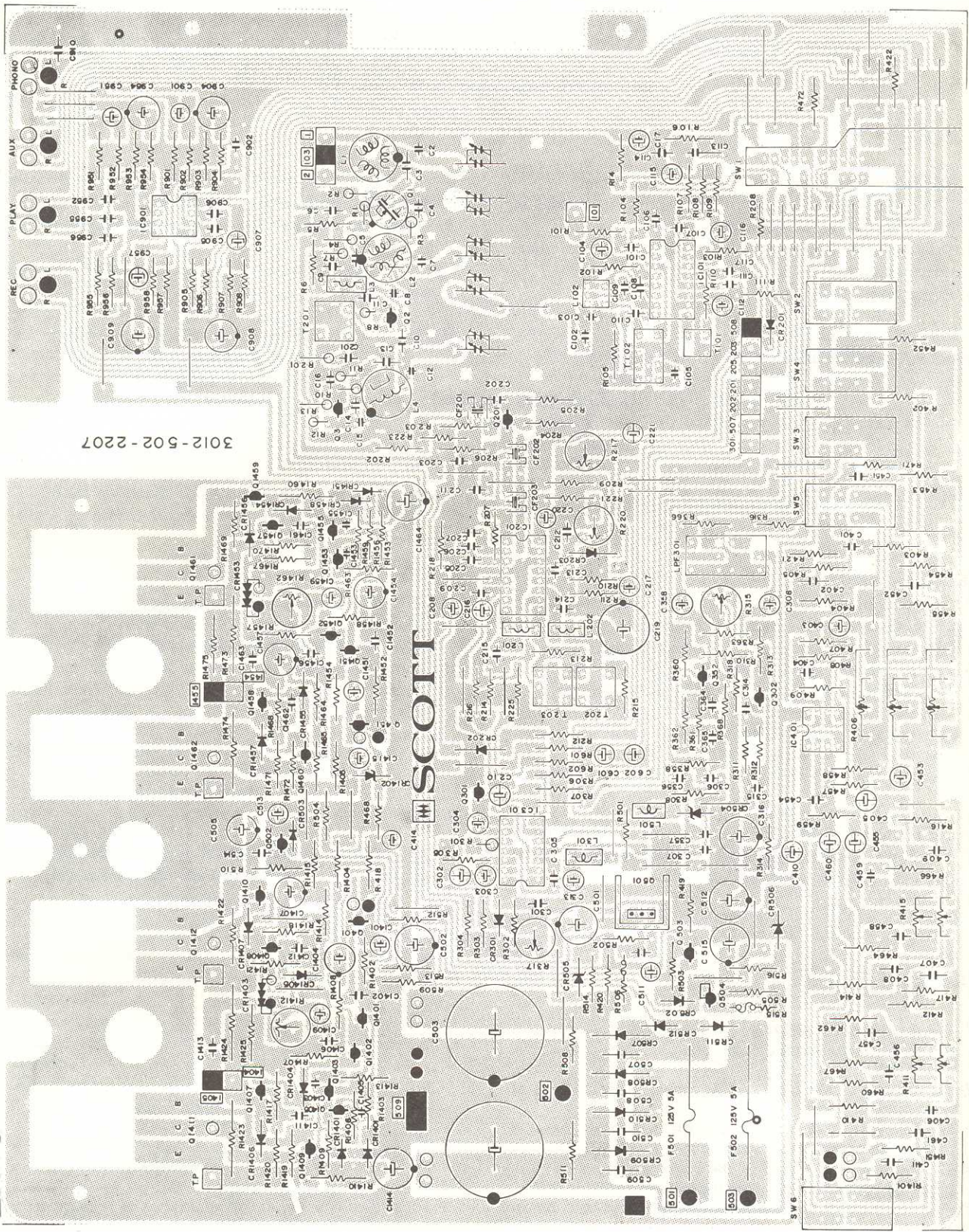

3012-502-2207

SCOTT

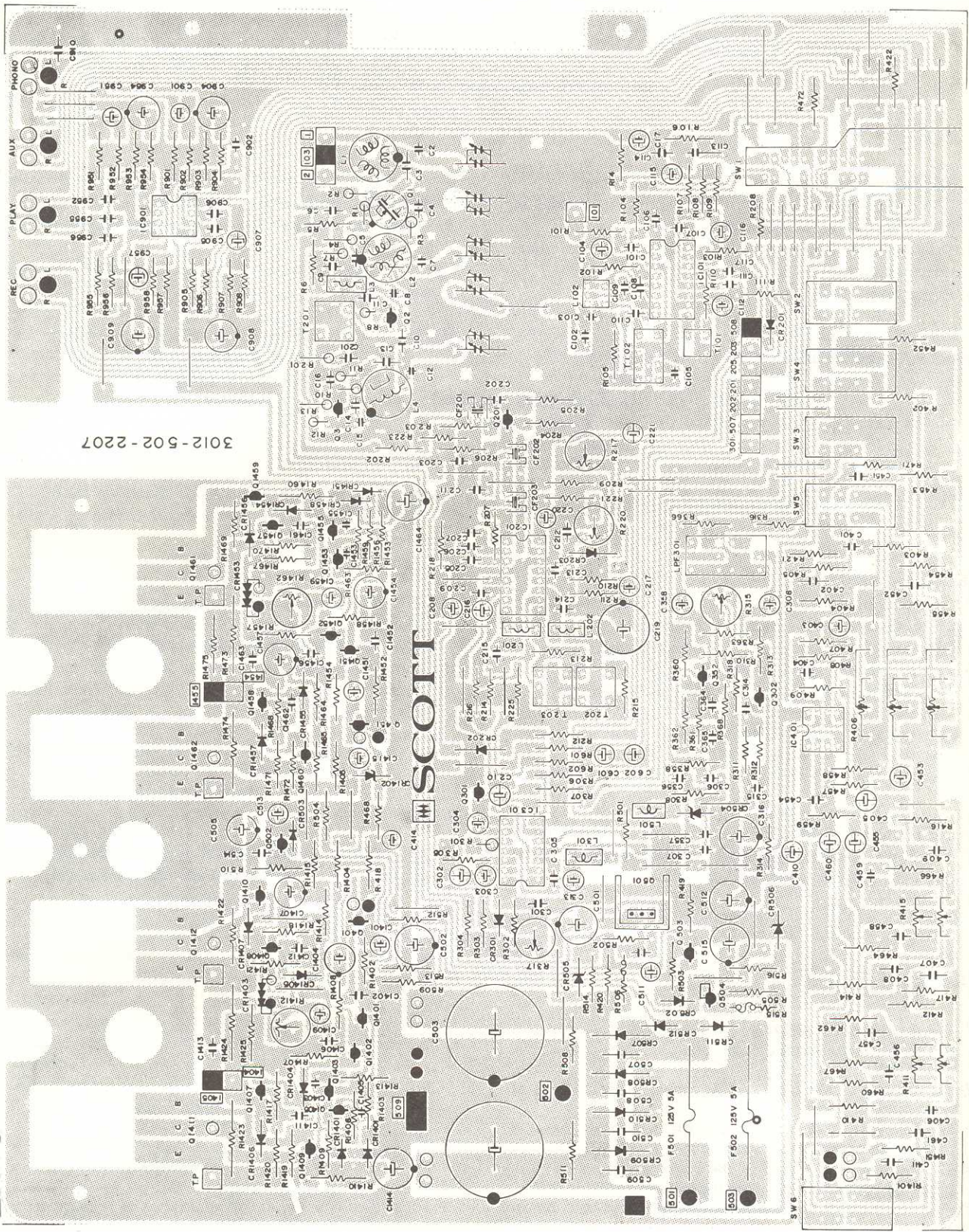

SCOTT 325R/335R

Symbol/ Exp. View No.	Description	Specification	Part No.	Used In
	Power transformer	117V	2869-177-6103	335R
	Power transformer	117V	2869-192-0100	325R
	Tuning shaft	--	5104-506-5101	both
	Aux jack	PC-8 input	3334-500-8107	both
	Wheel, drum	Tuning cap drum	5224-501-1109	both
	Spring, dial	--	6674-501-9107	both
	Screw	Top cover mtg.	7128-540-2032	both
	Washer	Top cover mtg.	7734-500-1106	both
	Side cabinet, R	--	6103-500-1107	both
	Side cabinet, L	--	6103-500-2102	both
	Volume knob	--	7724-505-7108	both
	Rotary knob	Tone/selector	7724-505-6103	both
	Balance knob	Plastic	7724-506-0106	both
	Front panel	w/o window	7702-507-1207	335R
	Front panel	w/o window	7702-507-1100	325R
	Back plate, volume	--	7714-504-7100	both
	Window, dial	Plastic	7653-502-5104	both
	Pully, guide	--	5264-501-3104	both
	Pully, guide	--	5214-501-3104	both
	Bolt, decoration	--	7734-500-3205	both
	Bracket, guide pointer	--	6613-504-7109	both
	Cap - pointer	94HB ABS	8003-500-3106	both
	Scale, dial	0.8 AL	8012-503-6108	both
	Bracket, ant bar	--	6614-117-3100	both
	Coil, ant bar		2509-305-1016	both
	Terminal board, push	Spkr	3304-501-6105	both
	Jack, AC outlet	125V, 15A S1 6444	3334-500-1005	both
	Switch, push	ESB 70274T spst	3529-102-0200	both
	Foot	Rubber, black	6074-500-2101	both
	Cabinet, top	1.0T vinyl on steel	6102-502-5106	both
	Guide, knob	PE Soft Natural	6463-500-1106	both
	Knob, tuning	ALB	7724-505-5108	both
	Varicon, air	C-752-J	1809-317-0201	both
	Jack, earphone	HLJ0190-01-020 3P	3333-101-7102	both
	Switch, push	SUF33 2C2P	3529-203-0406	both
		H12.5x 2/H18		
	Potentiometer	GM70E20FM7C100K	1269-111-1309	both
	Potentiometer	FJ60E25FM11W250K	1299-102-0107	both
		B100K		
	Switch, push	SUF43 H=18mm	3529-203-0503	both
.SW1	Switch, rotary, slide	HRW0332-01-250 4C4P	3509-101-0207	both
(C503,504)	Knob, mould balance	ABS black	8414-500-3100	both
	Capacitor, elect	35V 6800M-PCB	1619-018-2400	both
	Dial cord		0729-140-2016	both
	Terminal board, screw	4T screw	3304-101-5201	both
	Guide, knob P	ABS grey	6464-501-5106	both
	Spring, push knob P	STS #27 P10.4	6674-506-5102	both
	Knob, push P	94HB ABS	7724-505-8103	both
	Guide, knob F	94HB ABS Sanding	6463-500-7106	both

Transistors

Symbol/ Exp. View No.	Description	Specification	Part No.	Used In
Q501	FET	3SK 45	2139-601-4602	both
Q502, 503	Transistor, bipolar	KSC1674-0	2139-301-0508	both
Q201	Transistor, bipolar	KSC838-0	2139-301-5808	both
Q301, 503, 1407, 1457, 601, 602	Transistor, bipolar	KSC945-Y	2139-302-7409	both
Q801, 851	Transistor, bipolar	KSC945-Y	2139-302-7409	335R
Q603, 604, 605, 1408, 1458	Transistor, bipolar	KSA733-Y	2139-301-3802	both
Q302, 352	Transistor, bipolar	KSA539-Y	2139-103-2904	both
Q501	Transistor, bipolar	KSD288-0	2149-401-2609	both
Q502, 504, 1403, 1405, 1410, 1453, 1455, 1460	Transistor, bipolar	KSA708-Y	2139-103-7103	both
Q1401, 1402, 1451, 1452	Transistor, bipolar	KTC-2440-BL	2139-305-6704	both
Q1409, 1459	Transistor, bipolar	KSC-1008-Y	2149-301-4309	both
Q1411, 1461	Transistor, output	TIP-41B	2149-305-1102	325R
Q1412, 1462	Transistor, output	TIP-42B	2149-201-9606	325R
Q1411, 1461	*Transistor, output	2SC1827	2149-301-710	325R
Q1412, 1462	*Transistor, output	2SA769Y	2149-101-430	325R
Q1411, 1461	Transistor, output	2SC2577-Y	2149-401-3206	335R
Q1412, 1462	Transistor, output	2SA1102-Y	2149-201-0106	335R

NOTE! *Used in 325R with SN 11050001 and up.

Diodes

CR201, 202, 203, 301, 502, 503, 1401, 1404 1405, 1408, 1451 1454, 1455, 204 1458, 605	Diode, switching	1SS53	2169-301-2901	325R 335R
CR804, 854, 805, 855, 806, 856, 807, 857, 808, 858	Diode, switching	1SS53	2169-301-2901	335R
CR505, 506	Diode, zener	1Z14	2169-404-1700	325R
CR505, 506	Diode, zener	RD18E	2169-403-2207	335R
CR504, 1402	Diode, zener	RD12E	2169-403-1105	335R
CR507, 508, 509, 510	Diode, rectifier	IN5173 - 300V, 2A	2169-201-1305	both
CR511, 512	Diode, rectifier	IN4001 - 50V, 1A	2169-201-0504	both
CR1406, 1407, 1456, 1457	Diode, rectifier	IN4003 - 200V, 1A	2169-201-0708	both
CR1403, 1453	Varistor	STV-3H	2189-105-1007	both
CR601	LED - meter	LN-05202P	2309-117-0102	both
CR302, 801, 851, 604	LED - square	LN217RP	2309-120-0102	both
CR802, 852	LED - meter	LN5302P GRN	2309-119-0205	335R
CR803, 853	LED - square	LN317 GP	2309-119-0108	335R
CR602, 603	LED - stereo	LD57A GRN 5P1	2309-101-7506	both

SCHEMATIC DIAGRAM 335R

335R

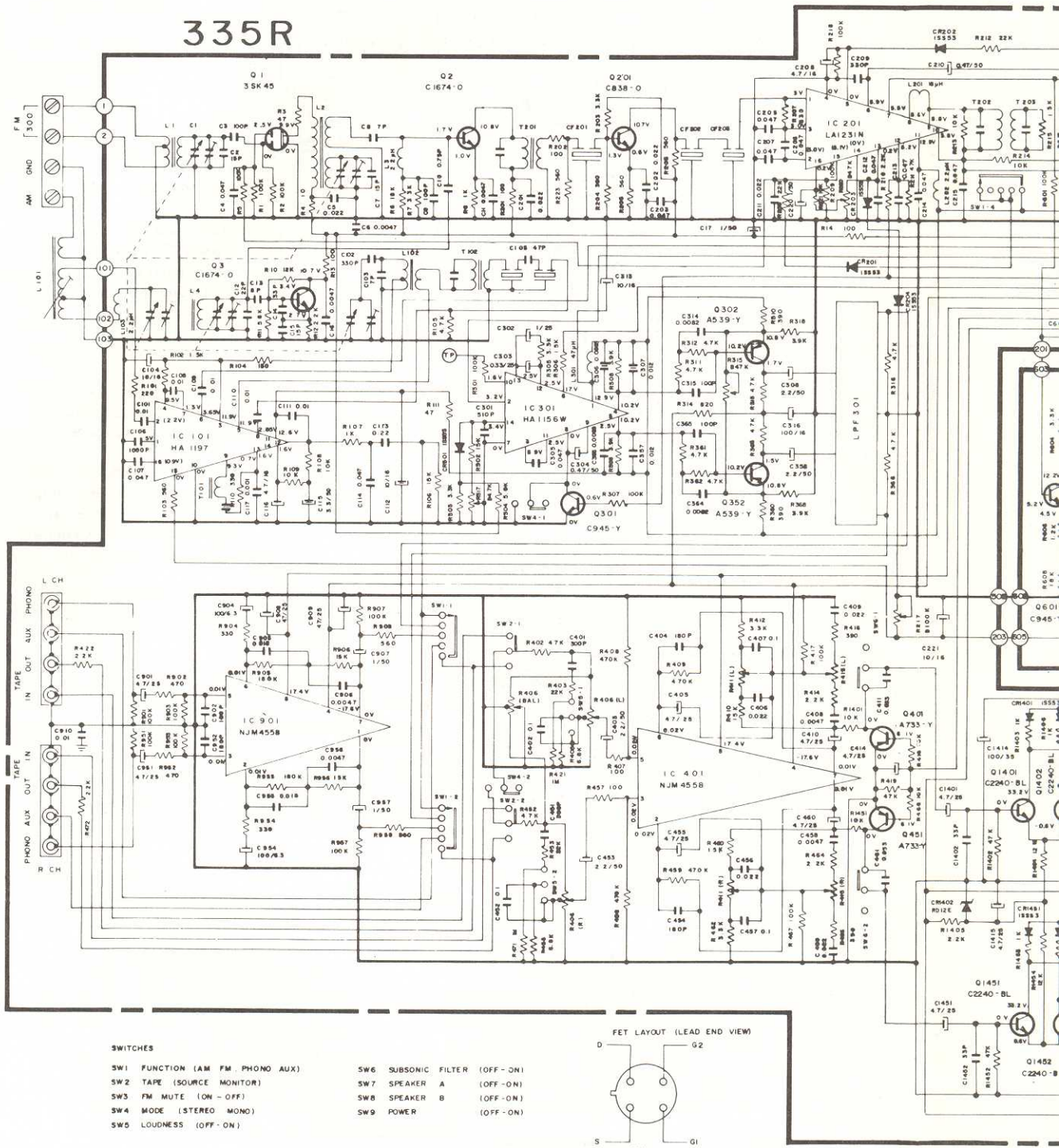

SWITCHES

- SW1 FUNCTION (AM FM PHONO AUX)
- SW2 TAPE (SOURCE MONITOR)
- SW3 FM MUTE (ON - OFF)
- SW4 MODE (STEREO MONO)
- SW5 LOUDNESS (OFF - ON)
- SW6 SUBSONIC FILTER (OFF - ON)
- SW7 SPEAKER A (OFF - ON)
- SW8 SPEAKER B (OFF - ON)
- SW9 POWER (OFF - ON)

FET LAYOUT (LEAD END VIEW)

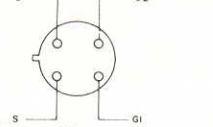

TRANSISTOR LAYOUT (LEAD END VIEW)

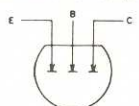

FRONT VIEW

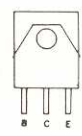
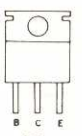

TOP VIEW

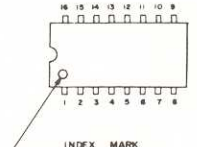

INDEX MARK

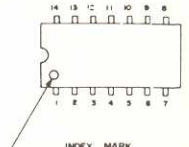

- Q2 Q3 Q201 Q301 Q302 Q352 Q502 Q503
- Q601 Q602 Q603 Q604 Q1401 Q1451 Q1402 Q1452
- Q1405 Q1455 Q1407 Q1457 Q1408 Q1458 Q1409
- Q1459 Q1410 Q1460

- Q1411 Q1461
- Q1412 Q1462

- IC101, IC201
- IC601 IC801, IC851

- IC301

- IC401
- IC901

NOTICE:

MANY OF THE TRANSISTORS USED IN THIS CIRCUIT ARE IDENTIFIED BY A "K" PREFIX IN PLACE OF THE MORE FAMILIAR "2". WHEN IT IS NECESSARY TO REPLACE DEVICES THE 2 SERIES MAY BE USED HOWEVER SERVICE PERSONNEL MUST OBSERVE PROPER LEAD CONNECTIONS.

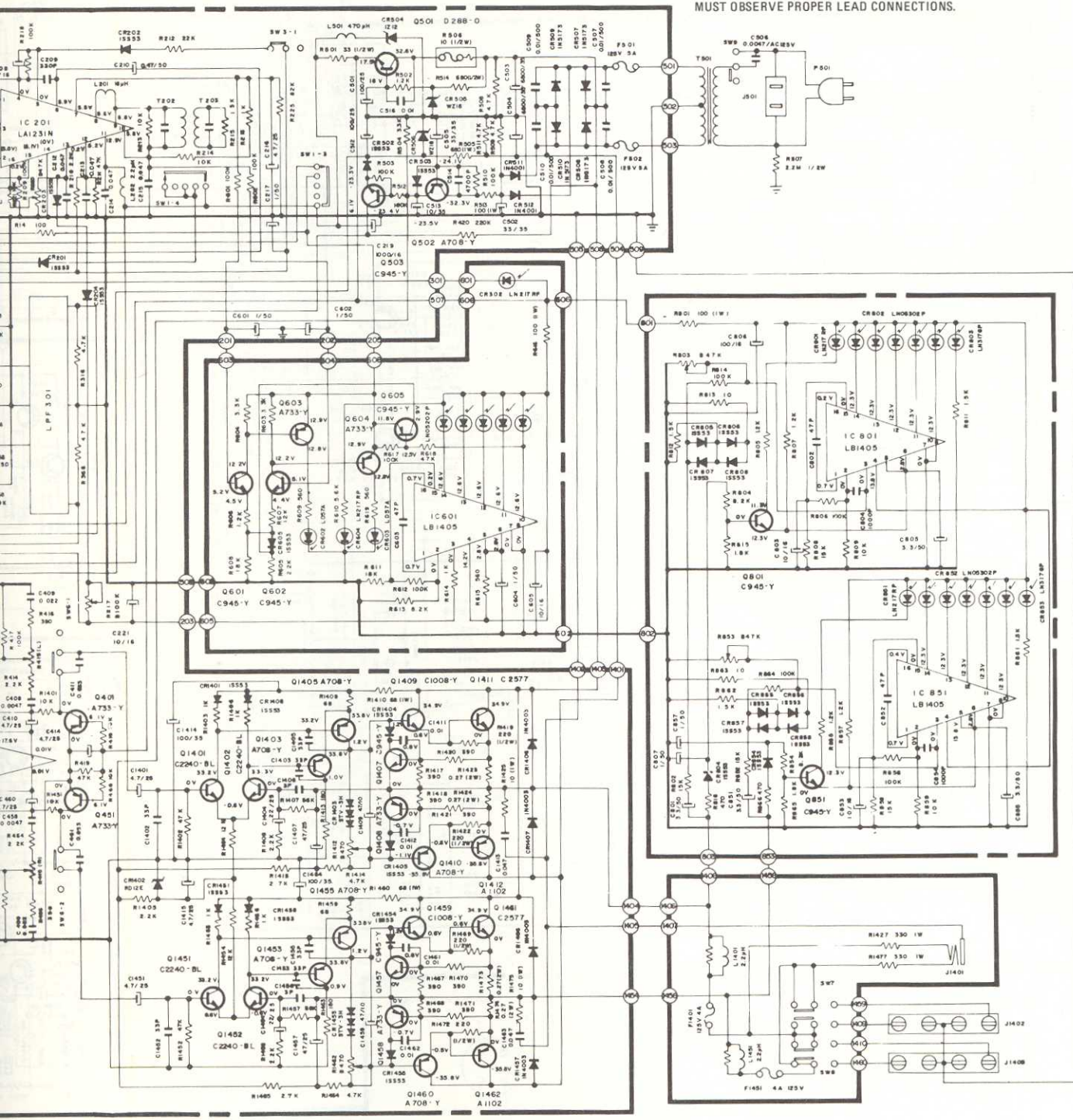

NOTE

1. ALL RESISTANCE VALUES IN OHM K K OHM M MEGA OHM, ALL RESISTORS 1/4W UNLESS OTHERWISE SPECIFIED
2. UNLESS OTHERWISE NOTED IN SCHEMATIC ALL CAPACITORS IN MFD PF, PICOFARAD
3. THERE MIGHT BE SLIGHT CHANGES IN THE ACTUAL SET.
4. ALL VOLTAGES ARE DC UNLESS OTHERWISE SPECIFIED, DC VOLTAGES SHOWN ARE MEASURED FROM CHASSIS WITH NO SIGNAL INPUT, LOUDNESS SWITCH IN OFF POSITION, LINE VOLTAGE 120V USING A HIGH IMPEDANCE DIGITAL MULTIMETER

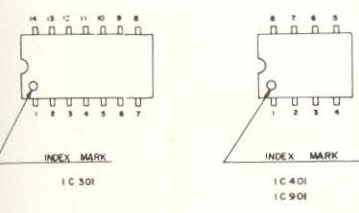

IC 301
IC 401
IC 901

SCHEMATIC DIAGRAM 335R

NOTICE:
 MANY OF THE TRANSISTORS USED IN THIS CIRCUIT ARE IDENTIFIED BY A "K" PREFIX IN PLACE OF THE MORE FAMILIAR "2".
 WHEN IT IS NECESSARY TO REPLACE DEVICES THE 2 SERIES MAY BE USED HOWEVER SERVICE PERSONNEL MUST OBSERVE PROPER LEAD CONNECTIONS.

335R

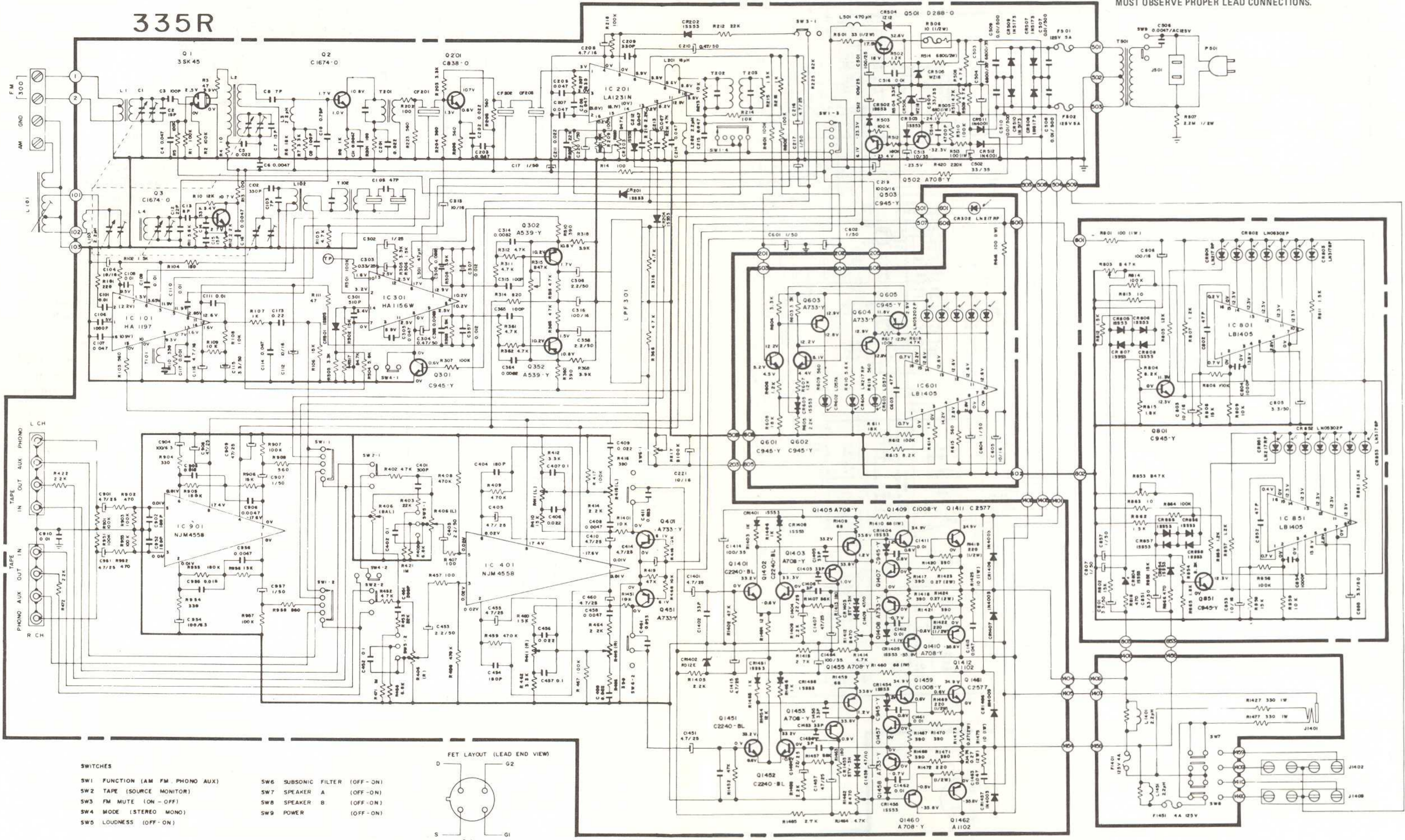

- SWITCHES**
- SW1 FUNCTION (AM FM PHONO AUX)
 - SW2 TAPE (SOURCE MONITOR)
 - SW3 FM MUTE (ON - OFF)
 - SW4 MODE (STEREO MONO)
 - SW5 LOUDNESS (OFF - ON)
 - SW6 SUBSONIC FILTER (OFF - ON)
 - SW7 SPEAKER A (OFF - ON)
 - SW8 SPEAKER B (OFF - ON)
 - SW9 POWER (OFF - ON)

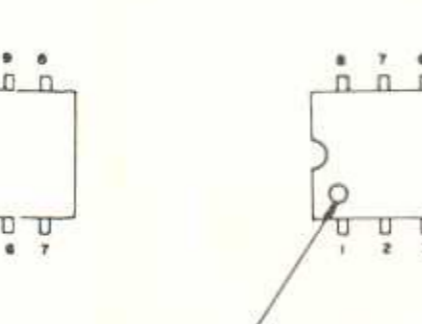
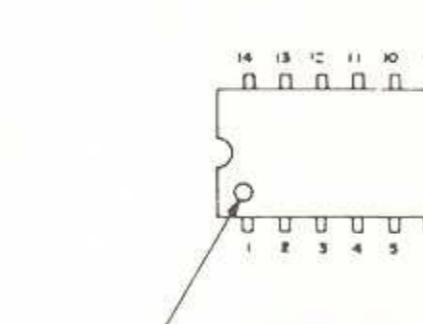
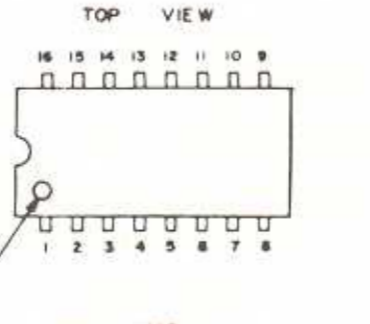
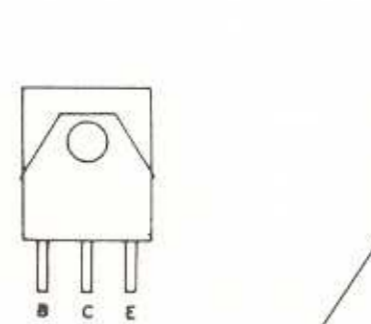
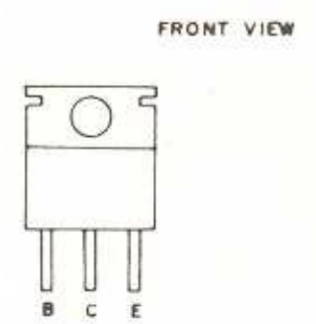
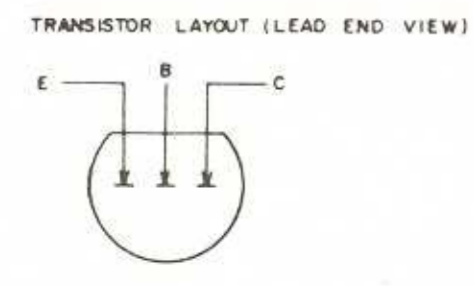
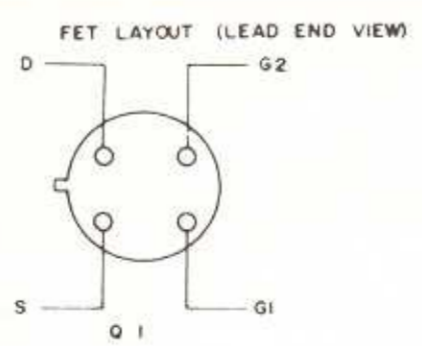

- NOTE**
1. ALL RESISTANCE VALUES IN OHM K K OHM M MEGA OHM, ALL RESISTORS 1/4W UNLESS OTHERWISE SPECIFIED
 2. UNLESS OTHERWISE NOTED IN SCHEMATIC ALL CAPACITORS IN MFD PF, PICO FARAD
 3. THERE MIGHT BE SLIGHT CHANGES IN THE ACTUAL SET.
 4. ALL VOLTAGES ARE DC UNLESS OTHERWISE SPECIFIED, DC VOLTAGES SHOWN ARE MEASURED FROM CHASSIS
- WITH NO SIGNAL INPUT, LOUDNESS SWITCH IN OFF POSITION, LINE VOLTAGE 120V USING
 A HIGH IMPEDANCE DIGITAL MULTIMETER

- Q2 Q3 Q201 Q301 Q302 Q352 Q502 Q503
 Q601 Q602 Q603 Q604 Q1401 Q1451 Q1402 Q1452
 Q1405 Q1455 Q1407 Q1457 Q1408 Q1458 Q1409
 Q1459 Q1410 Q1460

- Q1411 Q1461
 Q1412 Q1462

- IC101, IC201
 IC601 IC801, IC851

- IC301

- IC401
 IC901

SCHEMATIC DIAGRAM 325R

SCOTT 325R/335R

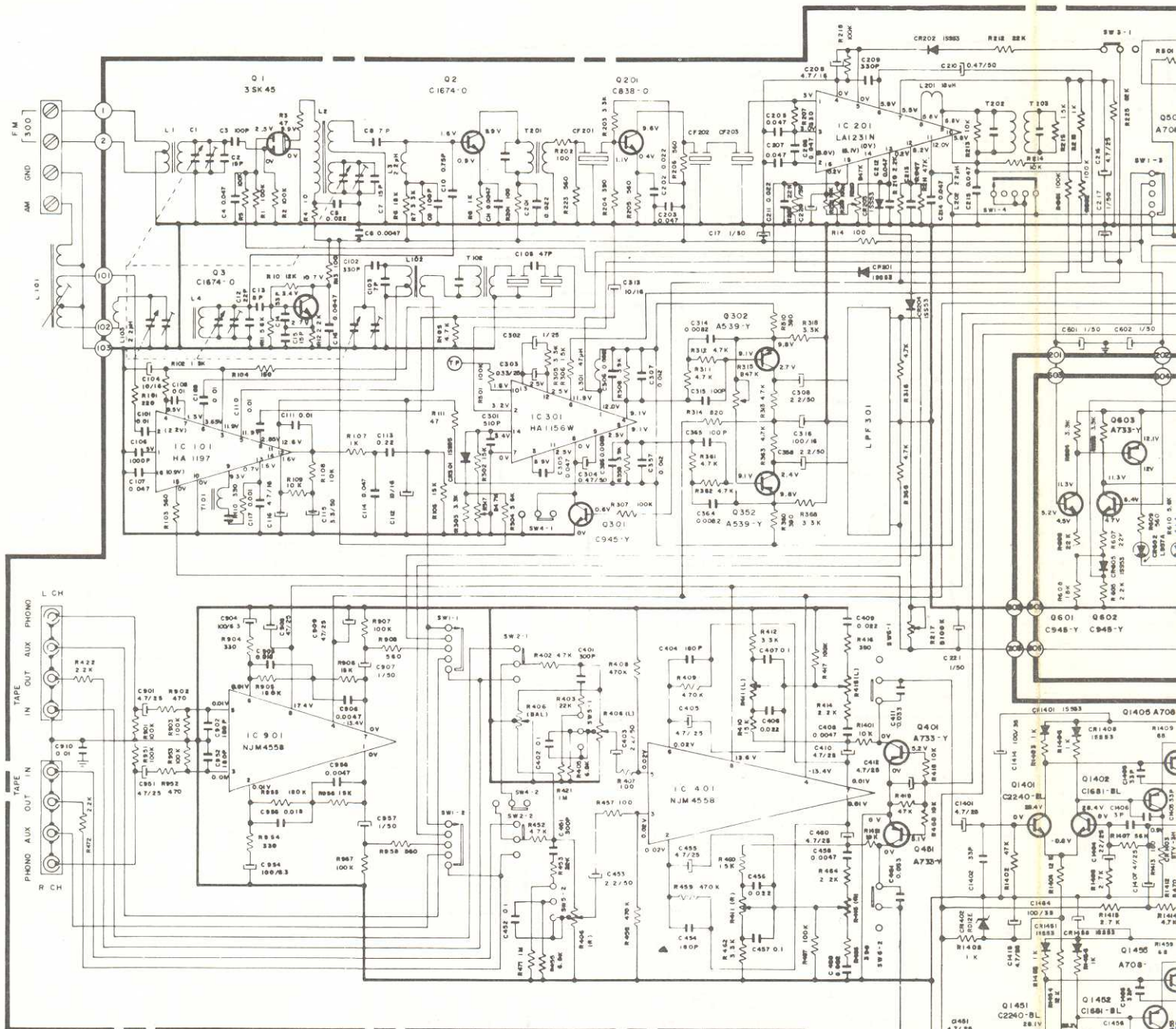

SWITCHES

- SW1 FUNCTION (AM FM PHONO AUX)
- SW2 TAPE (SOURCE MONITOR)
- SW3 FM MUTE (ON-OFF)
- SW4 MODE (STEREO MONO)
- SW5 LOUDNESS (OFF-ON)
- SW6 SUBSONIC FILTER (OFF-ON)
- SW7 SPEAKER A (OFF-ON)
- SW8 SPEAKER B (OFF-ON)
- SW9 POWER (OFF-ON)

TRANSISTOR LAYOUT (LEAD END VIEW)

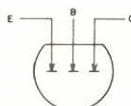

FRONT VIEW



FET LAYOUT (LEAD END VIEW)

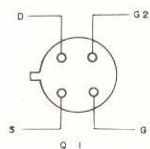

TOP VIEW

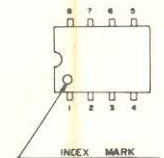
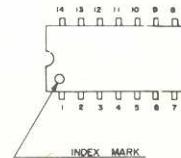
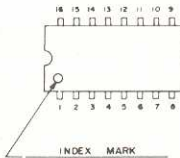

- Q2 Q3 Q201 Q301 Q302 Q352 Q502 Q503
- Q601 Q602 Q603 Q604 Q1401 Q1451 Q1402 Q1452
- Q1405 Q1455 Q1407 Q1457 Q1408 Q1458 Q1409
- Q1459 Q1410 Q1460

- Q1411 Q1461
- Q1412 Q1462

- IC101, IC201
- IC601

- IC301

- IC401
- IC901

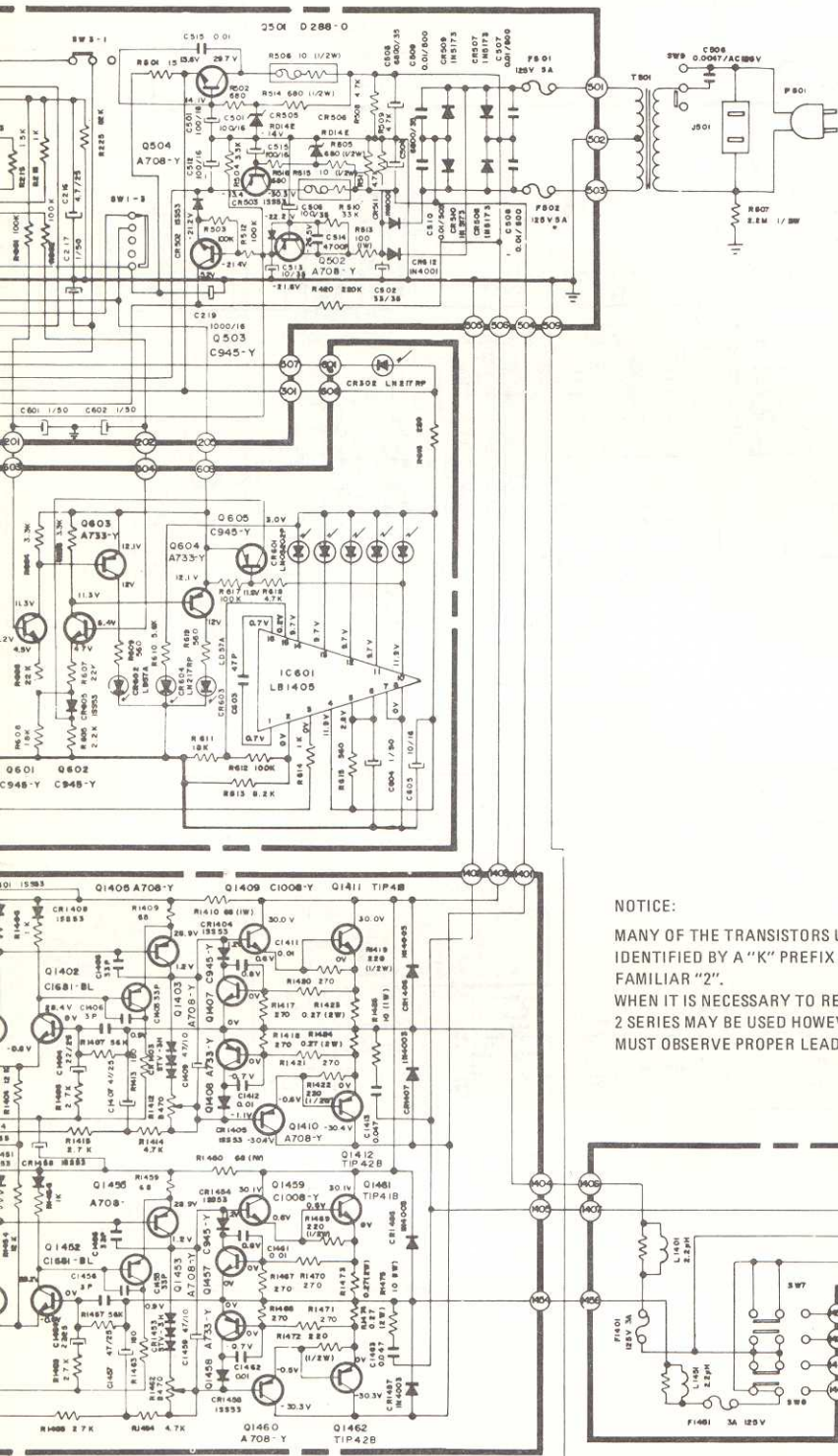

REVISIONS

325R

Output transistor change: Serial No. 11050001 and up. Q1411, 1461 from tip 41B to KSC 1827-4 Q1412, 1462 from tip 42B to KSA 769-4.

325R - 335R

Power Transformer

Three types of power transformers may be supplied, any one of the three is suitable for replacement.

325R
Pt. No.

335R
Pt. No.

2869-192-0100
2869-192-040
2869-192-050

2869-177-6103
2869-177-640
2869-177-650

325R - 335R

Commencing with serial number 11030001 both models have a primary fuse installed, the fuse is mounted in an in-line fuse holder accessible only after top cover removal. 325R uses a 2A 250V fuse, 335R uses a 3A 250V fuse.

325R - 335R

Resistors, R1414 and R1464 in the output bias circuit changed from 4.7K to 3.9K.

NOTICE:

MANY OF THE TRANSISTORS USED IN THIS CIRCUIT ARE IDENTIFIED BY A "K" PREFIX IN PLACE OF THE MORE FAMILIAR "2".
WHEN IT IS NECESSARY TO REPLACE DEVICES THE 2 SERIES MAY BE USED HOWEVER SERVICE PERSONNEL MUST OBSERVE PROPER LEAD CONNECTIONS.

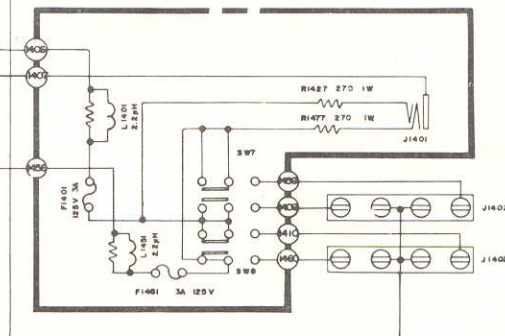

NOTE

1. ALL RESISTANCE VALUES IN OHM K K OHM M MEGA OHM, ALL RESISTORS 1/4W UNLESS OTHERWISE SPECIFIED
2. UNLESS OTHERWISE NOTED IN SCHEMATIC ALL CAPACITORS IN MFD PF: PICOFARAD.
3. THERE MIGHT BE SLIGHT CHANGES IN THE ACTUAL SET.
4. ALL VOLTAGES ARE DC UNLESS OTHERWISE SPECIFIED, DC VOLTAGES SHOWN ARE MEASURED FROM CHASSIS

WITH NO SIGNAL INPUT, LOUDNESS SWITCH IN "OFF" POSITION, LINE VOLTAGE 120V USING

A HIGH IMPEDANCE DIGITAL MULTIMETER.

7 6 5
2 3 4
X MARK
401
901

SCHEMATIC DIAGRAM 325R

SCOTT 325R/335R

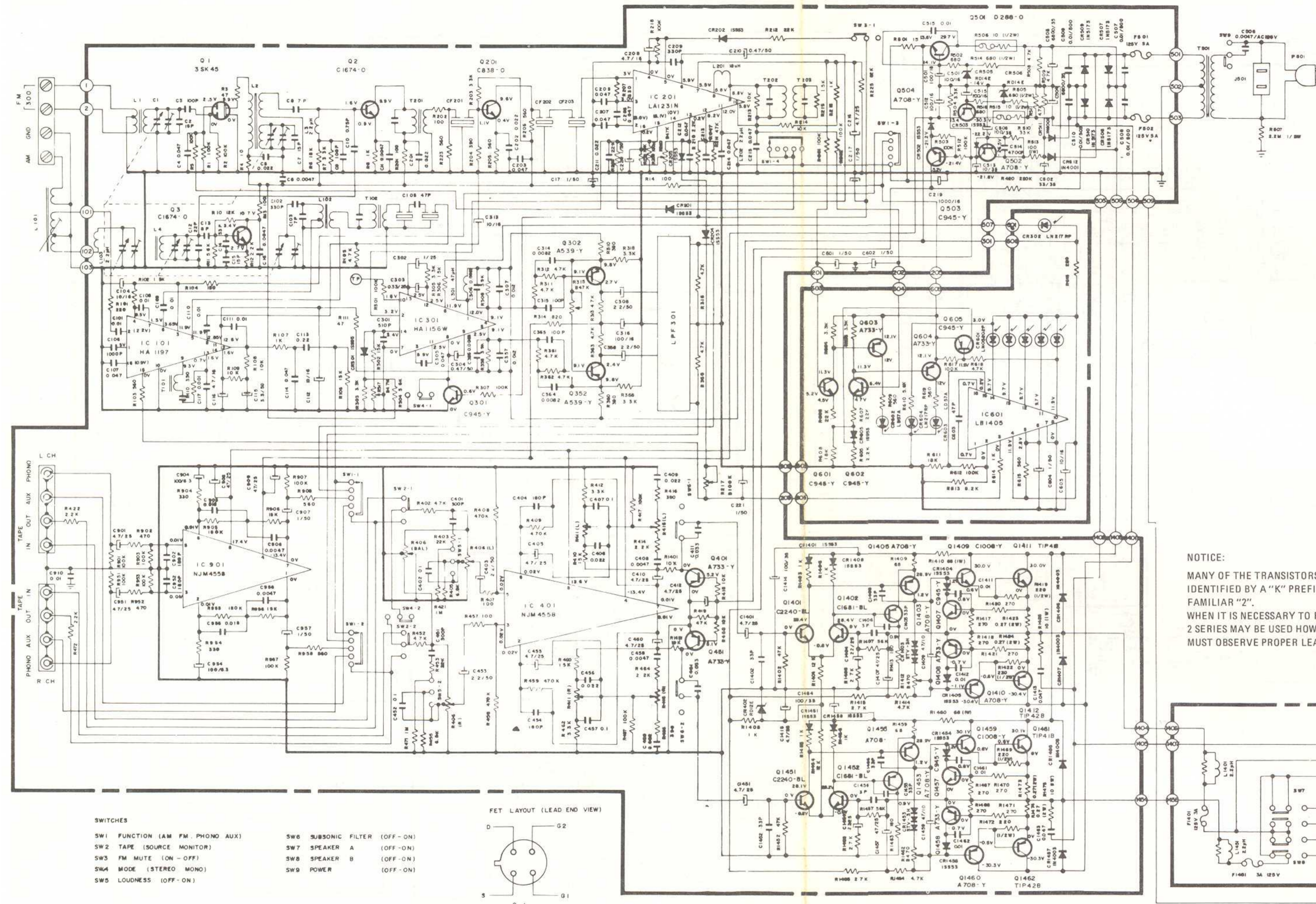

REVISIONS

325R
Output transistor change: Serial No. 11050001 and up, Q1411, 1461 from tip 41B to KSC 1827-4 Q1412, 1462 from tip 42B to KSA 769-4.

325R - 335R
Power Transformer
Three types of power transformers may be supplied, any one of the three is suitable for replacement.

325R Pt. No.	335R Pt. No.
2869-192-0100	2869-177-6103
2869-192-040	2869-177-640
2869-192-050	2869-177-650

325R - 335R
Commencing with serial number 11030001 both models have a primary fuse installed, the fuse is mounted in an in-line fuse holder accessible only after top cover removal. 325R uses a 2A 250V fuse, 335R uses a 3A 250V fuse.

325R - 335R
Resistors, R1414 and R1464 in the output bias circuit changed from 4.7K to 3.9K.

NOTICE:

MANY OF THE TRANSISTORS USED IN THIS CIRCUIT ARE IDENTIFIED BY A "K" PREFIX IN PLACE OF THE MORE FAMILIAR "2". WHEN IT IS NECESSARY TO REPLACE DEVICES THE 2 SERIES MAY BE USED HOWEVER SERVICE PERSONNEL MUST OBSERVE PROPER LEAD CONNECTIONS.

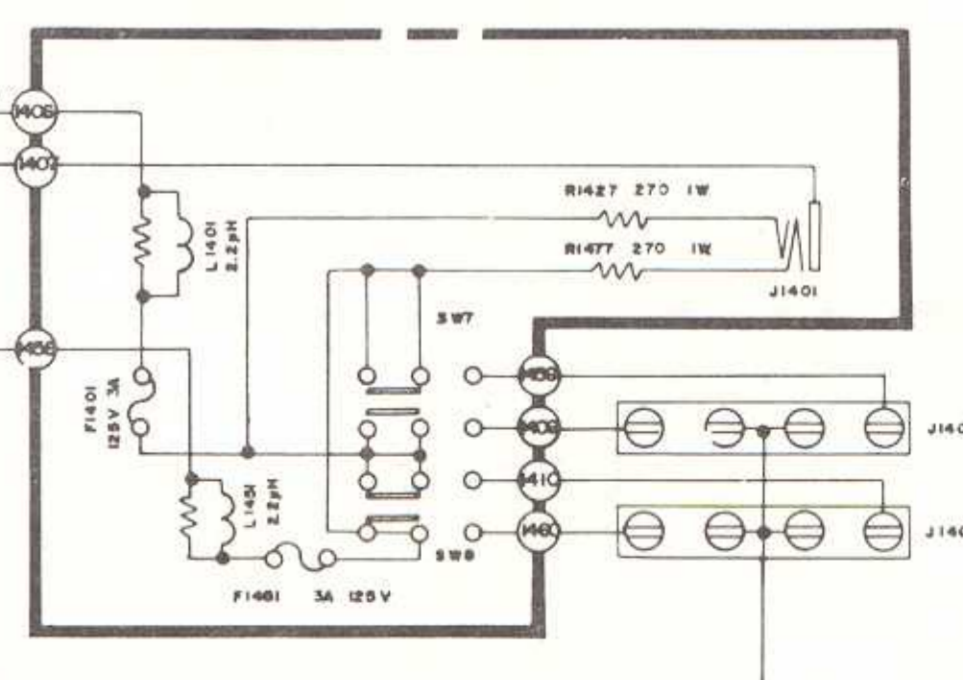

- SWITCHES**
- SW1 FUNCTION (AM FM. PHONO AUX)
 - SW2 TAPE (SOURCE MONITOR)
 - SW3 FM MUTE (ON-OFF)
 - SW4 MODE (STEREO MONO)
 - SW5 LOUDNESS (OFF-ON)
 - SW6 SUBSONIC FILTER (OFF-ON)
 - SW7 SPEAKER A (OFF-ON)
 - SW8 SPEAKER B (OFF-ON)
 - SW9 POWER (OFF-ON)

TRANSISTOR LAYOUT (LEAD END VIEW)

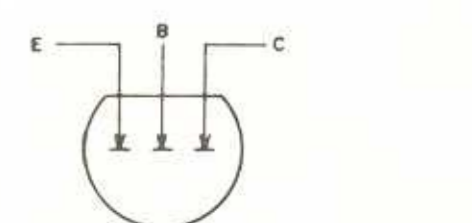

RONT VIEW

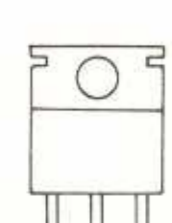

FET LAYOUT (LEAD END VIEW)

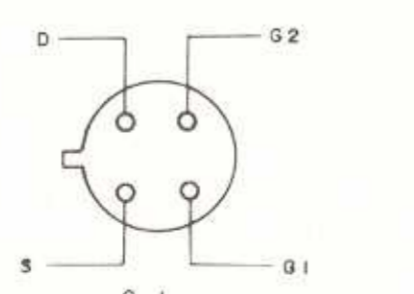

TOP VIEW

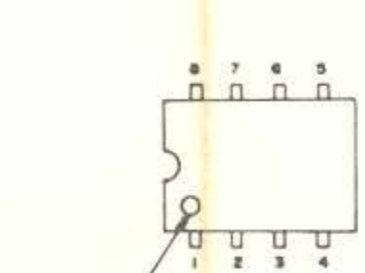
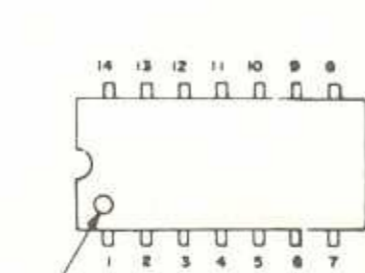
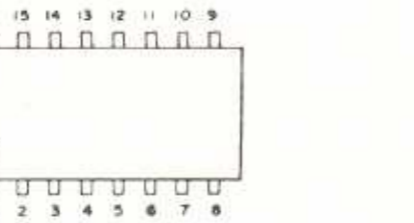

NOTE

- ALL RESISTANCE VALUES IN OHM K K.OHM M:MEGA OHM, ALL RESISTORS 1/4W UNLESS OTHERWISE SPECIFIED.
- UNLESS OTHERWISE NOTED IN SCHEMATIC ALL CAPACITORS IN MFD PF:PICOFARAD.
- THERE MIGHT BE SLIGHT CHANGES IN THE ACTUAL SET.
- ALL VOLTAGES ARE DC UNLESS OTHERWISE SPECIFIED, DC VOLTAGES SHOWN ARE MEASURED FROM CHASSIS WITH NO SIGNAL INPUT, LOUDNESS SWITCH IN 'OFF' POSITION, LINE VOLTAGE 120V USING A HIGH IMPEDANCE DIGITAL MULTIMETER.

Q2 Q3 Q201 Q301 Q302 Q352 Q502 Q503
Q601 Q602 Q603 Q604 Q1401 Q1451 Q1402 Q1452
Q1405 Q1455 Q1407 Q1457 Q1408 Q1458 Q1409
Q1459 Q1410 Q1460

Q504
Q1411 Q1461
Q1412 Q1462

IC101, IC201
IC601

IC301

IC401
IC901

SCOTT 325R/335R

Symbol/ Exp. View No.	Description	Specification	Part No.	Used In
L-1	Coil - ant, FM	100MHZ 0.7 PI UEW	2509-015-0103	both
L-2	Coil - RF, MM	100MHZ 0.7 PI UEW	2519-004-0104	both
L140, 151	Coil - choke 3P	2.2UH-K W/RD	2429-006-0102	both
L-3, L202	Coil - choke	2.2 UH-K 030	2429-002-0100	both
L-4	Coil - OSC, FM	100MHZ 0.7 PI	2539-007-0103	both
L-201	Coil - choke	18UH-K Q30	2429-002-0508	both
L-301	Coil - choke	47UH-K Q30	2429-002-0702	both
L-102	Coil - OSC, MW	7mm can	2539-403-0204	both
T-102	Filter - ceramic, AM	7mm can	4529-313-0106	both
T-101	Trans - IF, AM	7mm can	2749-118-0204	both
T-201	Trans - IF, FM A	10mm can	2739-105-0209	both
T-202	Trans - IF, FM F	TKAEA 246 38AVO	2739-127-0100	both
T-203	Trans - IF, FM G	TKAE A 246 39X	2739-128-0103	both
CF201, 202, 203	Filter, ceramic	SFE 10.7MA8	4529-309-0103	both
LPF301	Low pass filter	208 BLRB-3451N	4529-415-0208	both
F501, 502	Fuse - w/lead	NOR 125V 5A	4709-131-3105	both
F140, 151	Fuse - w/lead	NOR 125V 3A	4709-131-2703	325R
F140, 151	Fuse - w/lead	NOR 125V 4A	4709-131-3009	335R
R217	VR - semi	SR19R B100K	1249-102-0704	both
R220, 315	VR - semi	SR19R B47K	1249-102-0607	both
R317	VR - semi	SR19R B4.7K	1249-102-0209	both
R1412, 1462	VR - semi	SR19R B470	1249-102-0102	both
R1410, 1460	Resistor, metal oxide	RS1P-68 1W	1049-301-1106	both
R1423, 1424, 1473, 1474	Res, cement, metal	RS2P 0.27J	1049-901-3605	both
IC601	IC - display	LB1405	2119-203-4000	both
IC101	IC - AM IF	HA1197	2119-201-0907	both
IC201	IC - FM DET	LA1231N	2119-201-0208	both
IC301	IC - MPX	HA1196W	2119-202-1701	both
IC401, 901	IC - tone, pre	NJM4558D	2119-401-0303	both
IC801, 851	IC - display	LB1405	2119-203-4000	335R
C1404, 1464, 505	Cap, elect	CE04W 35V 100M	1609-402-1009	both
C502, 505	Cap, elect	CE04W 35V 33M	1609-402-0800	both
C904, 954	Cap, elect	CE04W 6.3V 100M	1609-401-1006	both
C513	Cap, elect	CE04W 35V 10M	1609-402-0606	both
C512	Cap, elect	CE04W 25V 100M	1609-401-6807	335
C303	Cap, alum solid	25V 0.33 M-K	1629-101-6208	both
C302	Cap, alum solid	25V 1M-K	1629-101-6509	both

Symbol/ Exp. View No.	Description	Specification	Part No.	Used In
R1425, 1475	Res, metal oxide	RS1P-10 1W	1049-301-0101	both
R142, 777	Res, metal oxide	RS1P-270 1W	1049-301-1805	325R
R506, 515	Res, fusible	RF1P-10 1W	1059-003-4008	both
R1427, 1477	Res, metal oxide	RS1P-330 1W	1049-301-1902	335R
R513, 801, 616	Res, metal oxide	RS1P-100 1W	1049-301-1300	both
R505	Res, metal oxide	RS1P 680 1W	1049-301-2305	335R

Capacitors

C301	Cap, polystyrene	CQ09S 50V 510J	1509-452-1108	both
C102	Cap, polystyrene	CQ09S 50V 330J	1509-452-1001	both
C305, 107, 1463, 1413, 114	Cap, polyester	M50V 0.047M-J	1509-121-2207	both
C307, 357	Cap, polyester	M50V 0.012M-J	1509-121-2100	both
C306, 356	Cap, polyester	M50V 0.0068M-J	1509-121-2102	both
C314, 364	Cap, polyester	M50V 0.0082M-J	1509-121-1309	both
C101, 108, 109, C113	Cap, polyester	M50V 0.01M-J	1509-121-1406	both
C117	Cap, polyester	M50V 0.12M-J	1509-121-2702	both
C402, 452, 407, 457	Cap, polyester	M50V 0.001M-J	1509-121-0100	both
C406, 456, 409, 459	Cap, polyester	M50V 0.1M-J	1509-121-2605	both
C411, 461	Cap, polyester	M50V 0.022M-J	1509-121-1804	both
C408, 458, 906, 956	Cap, polyester	M50V 0.033M-J	1509-121-2003	both
C905, 955	Cap, polyester	M50V 0.0047M-J	1509-121-1008	both
C604, 807, 857, 17, 220, 217, 601, 602, 907, 957	Cap, elect	M50V 0.018M-J	1509-121-1600	both
C605, 221, 313, 104, 112	Cap, elect	CE04W 50V 1M	1609-402-2101	both
C208, 116	Cap, elect	CE04W 50V 10M	1609-401-4302	both
C210, 304	Cap, elect	CE04W-16V 4.7M	1609-401-4205	both
C216, 410, 460, 1401, 1415, 1451, 901, 951, 405, 455, 414	Cap, elect	CE04W-50V 0.47	1609-402-2004	both
C219	Cap, elect	CE04W-25V 4.7M	1609-401-6302	both
C308, 358, 403, 453	Cap, elect	CE04W 16V 1000M	1609-401-5103	both
C316, 501, 512, 515, 806	Cap, elect	CE04W 50V 2.2M	1609-402-2208	both
C115, 801, 851, 805, 855	Cap, elect	CE04W 16V 100M	1609-401-4700	both
C1404, 1454	Cap, elect	CE04W-50V 3.3M	1609-402-2305	both
C1457, 908, 909, 1407	Cap, elect	CE04W 25V 22M	1609-401-6506	both
C1459, 1409	Cap, elect	CE04W 25V 47M	1609-401-6700	both
	Cap, elect	CE04W 10V 47M	1609-401-2700	both