

SERVICE MANUAL

stereo components

R306

R307

R307L

A406

A407

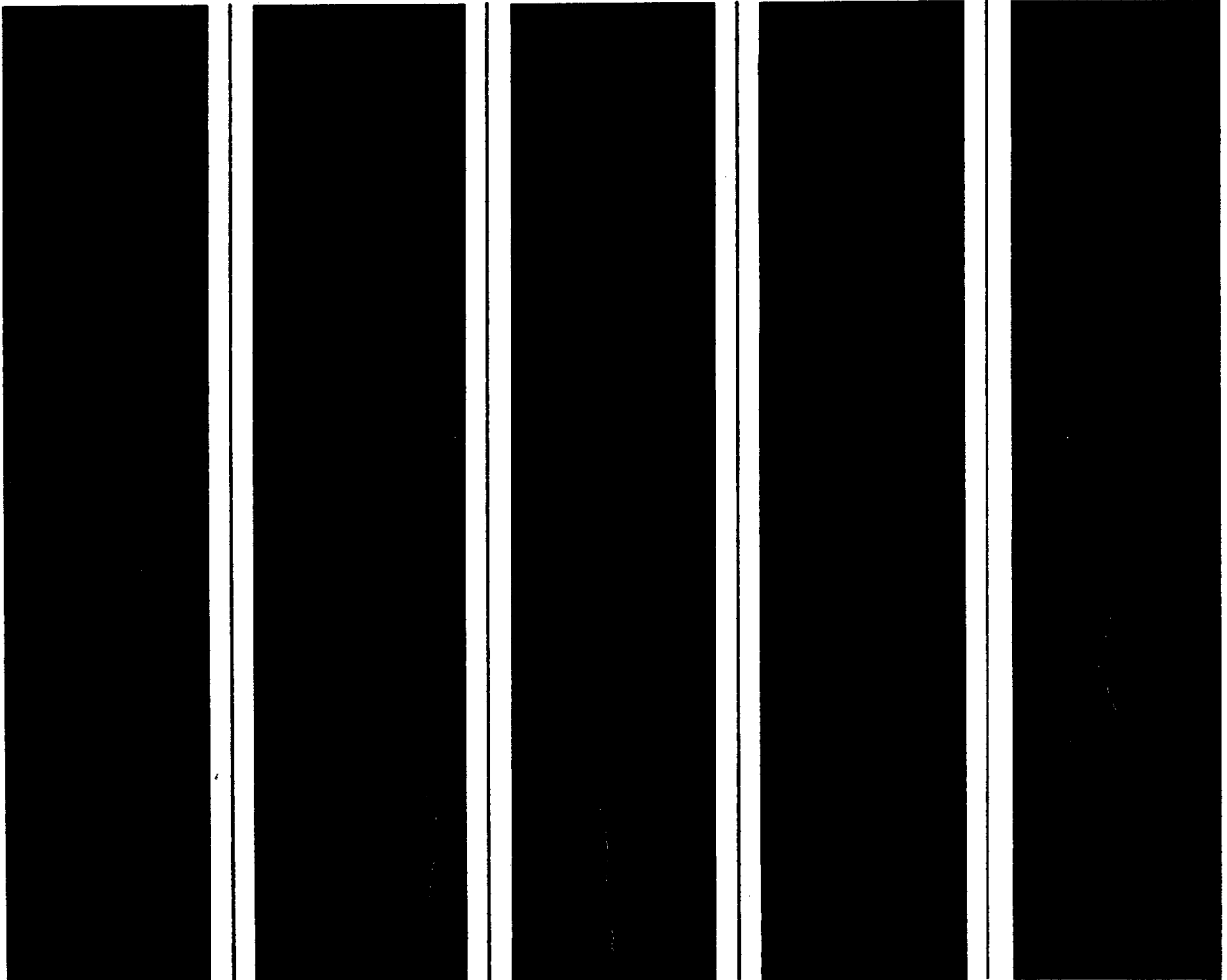

 **SCOTT**[®]
The Name to listen to.

H. H. SCOTT, INC., 20 Commerce Way, Woburn, Mass. 01801, Tel. 617 933-8800

-----NOTICE-----

The following safety precautions must be followed to assure continued reliability and safety against fire and shock hazard:

- 1.) Replacement parts used during servicing of this appliance must have identical characteristics as those offered and recommended by H. H. Scott, Inc.
- 2.) Satisfactory and approved service procedures dictate that ALL PARTS, no matter how apparently unimportant, be replaced exactly as in the original design.

EXAMPLES:

- a) Braided glass tubing over resistors.
 - b) Heatsinks on transistors.
 - c) Ceramic tube spacers.
 - d) All mechanical parts, i.e. covers, brackets, screws etc.
- 3.) A dielectric test is to be performed on each appliance following the re-assembly and before returning the unit to the customer.
 - 4.) The dielectric test, to be performed on H. H. Scott, Inc. electronic components serviced in the U. S. and Canada for use in these countries, shall consist of not less than the following:*
 - 1.) A dielectric tester designed to supply not less than 1100 volts at 60 Hz and employing leakage current indicator/s is to be used.
 - 2.) The tester is to be connected per the instructions enclosed with the instrument, or as follows:
 - a) The tester is connected to the power line receptacle, and the power switch is turned ON.
 - b) Sufficient time is allowed for the tester supply to stabilize and then the output voltage is adjusted for 1080 volts.
 - c) Leads of the tester, usually marked GND and HV, are connected between chassis GND and both blades of the male plug of the power cord.
 - d) Switch tester to "test" and observe leakage indicator.
- LEAKAGE CURRENT MUST NOT EXCEED 0.5 mA.

* Dielectric tests made by service personnel in countries other than United States and Canada must use test equipment and procedures specified by the safety agency serving that country.

EQUIPMENT SPECIFICATIONS

AMPLIFIER SECTION

	A406	A407	R306	R307/L
*Power Output	15 Watts	15 Watts	15 Watts	18 Watts***
Max. THD @rated output . . .	0.5% . . .	0.3% . . .	0.5% . . .	0.5%
Max. IMD @rated output . . .	0.3% . . .	0.3% . . .	0.5% . . .	0.3%
Input sensitivity - Phono . . .	2.5 mV . . .	2.5 mV . . .	2.5 mV . . .	2.5 mV
- Aux . . .	150 mV . . .	160 mV . . .	150 mV . . .	160 mV
Signal-to-noise ratio				
- Phono . . .	70 dB . . .	70 dB . . .	70 dB . . .	70 dB
- Aux . . .	80 dB . . .	80 dB . . .	80 dB . . .	80 dB
Separation - Phono . . .	42 dB . . .	42 dB . . .	42 dB . . .	42 dB
- Aux . . .	46 dB . . .	46 dB . . .	46 dB . . .	46 dB
Damping Factor	35 . . .	35 . . .	35 . . .	35

POWER REQUIREMENTS

Line voltage & Frequency . . All above listed units are 120 Volts AC; 60 Hz.

Power Consumption-Max. . . . 190W . . . 190W . . . 125W . . . 125W

WEIGHT

Net Weight	15 lbs . . .	15 lbs . . .	23 lbs . . .	23 lbs.
	6.8 kg	6.8 kg	10.5 kg	10.5 kg
Shipping Weight	16.2 lbs	16.2 lbs	26.6 lbs	26.6 lbs
	7.4 kg	7.4 kg	12.1 kg	12.1 kg

FM TUNER SECTION

	R306	R307/L
Tuning Range	87.5 - 108 MHz	87.5 - 108 MHz
Usable sensitivity - Mono . . .	12 dBf (2.2 μ V)	12 dBf (2.2 μ V)
- Stereo	30.3 dBf (18 μ V)	30.3 dBf (18 μ V)
Sensitivity for 50 dB signal-to-noise ratio		
- Mono	16.1 dBf (3.5 μ V)	16.1 dBf (3.5 μ V)
- Stereo	42.1 dBf (70 μ V)	42.1 dBf (70 μ V)
Signal-to-noise ratio at 65 dBf		
- Mono	68 dB	68 dB
- Stereo	65 dB	65 dB
Stereo Separation @ 1 kHz . . .	40 dB	40 dB
Stereo Threshold	7 to 15 μ V	7 to 15 μ V
Muting Threshold	7 to 15 μ V	7 to 15 μ V

AM TUNER SECTION

Tuning Range	515 - 1620 kHz	515 - 1620 kHz
Usable sensitivity	150 μ V/m	150 μ V/m
Selectivity, minimum	35 dB	35 dB
Signal-to-noise ratio	50 dB	50 dB
THD at 40% modulation	2%	2%

* Per H. H. Scott, Inc. output power statement as required by the Federal Trade Commission.

*** 40 Hz - 20 kHz.

DIAL CORD STRINGING INSTRUCTIONS—R306

- 1.) Start with tuning capacitor plates fully meshed; tuning drum turned all the way toward front of unit.
- 2.) Tie dial cord end to eyelet on tuning drum spoke closest to front of unit.
- 3.) Bring dial cord through inside slot of tuning drum.
- 4.) Follow arrow direction to pulley "A"; wind cord around flywheel capstan 3 full turns clockwise.
- 5.) Continue to pulleys "B", "C" and "D".
- 6.) Wind cord around tuning drum 2 1/2 turns clockwise.
- 7.) Attach spring to cord; bring cord through outside slot of tuning drum and attach spring to eyelet of spoke.
- 8.) Set pointer at "0" log and attach cord to tabs.
- 9.) Rotate tuning knob in both directions to check for satisfactory pointer travel and dial cord tension.
- 10.) A drop of suitable glue on pointer tabs is suggested to prevent slipping.

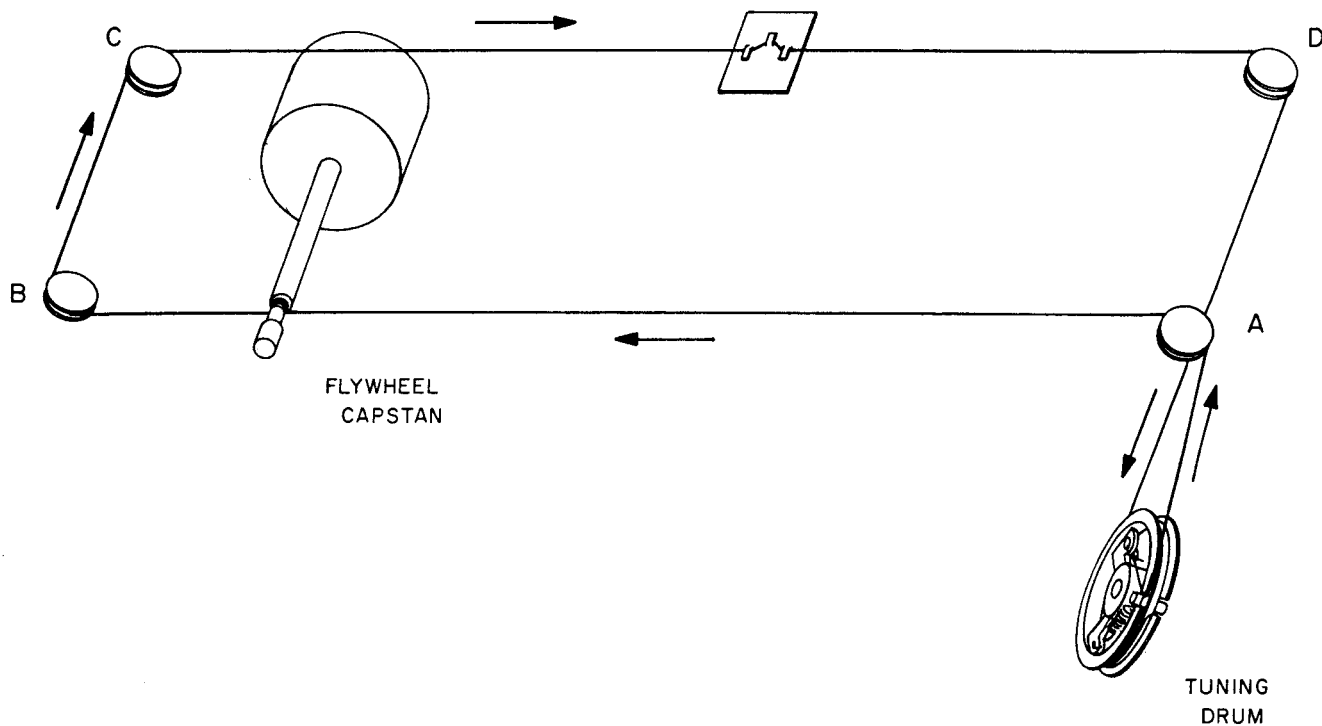

DIAL CORD STRINGING INSTRUCTIONS—R307

- 1.) With rear of unit facing you, turn front end drum all the way to the right. (plates open)
- 2.) Form fixed loop on one end of dial cord and attach to tab at inside top of front end drum.
- 3.) Bring dial cord through slot and follow arrows to pulley "A", "B", "C" and "D".
- 4.) Wrap cord 3 full turns around flywheel capstan, counterclockwise, and return to front end drum.
- 5.) Wind cord $2\frac{1}{2}$ turns around drum, clockwise, and attach to spring end protruding through slot in drum.
- 6.) Attach pointer to dial cord at tabs. Rotate tuning knob for satisfactory pointer travel and dial cord action. A drop of suitable glue on pointer tabs will prevent slipping of pointer.

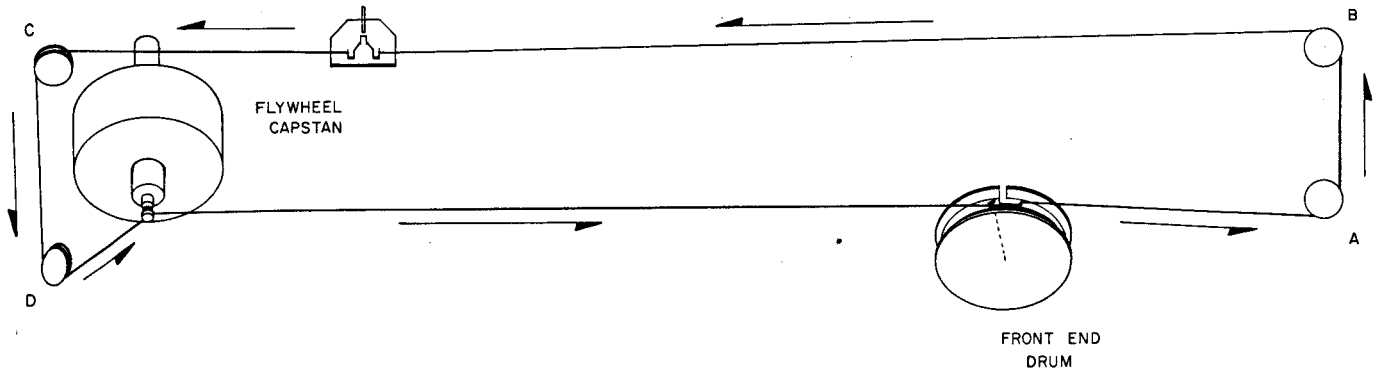

CIRCUIT DESCRIPTION OF THE POWER AMPLIFIER

Refer to schematic diagram

Q506 and Q510 are the power output devices and Q505 and Q509 are the drivers. These transistors provide current gain to drive the loudspeaker load. The differential input transistors, Q501 and Q502, along with the voltage amplifier, Q503, provide the necessary voltage gain and feedback to minimize distortion. Resistors, R505 and R506, control the amount of negative feedback and the gain of the driver.

Q504, with resistors R507, R508 and R509, set the bias in the output stage to maintain class AB operation and prevent crossover distortion. Q507 and Q508 are the protection transistors. The protection transistors will conduct when the AC voltage drop across R516 and R517 exceeds a preset level. This level is determined by R512, R513, R515 and R518. When the protection transistors conduct, they provide a short circuit signal path, that in turn, limits the signal drive on the base of Q505 and Q509.

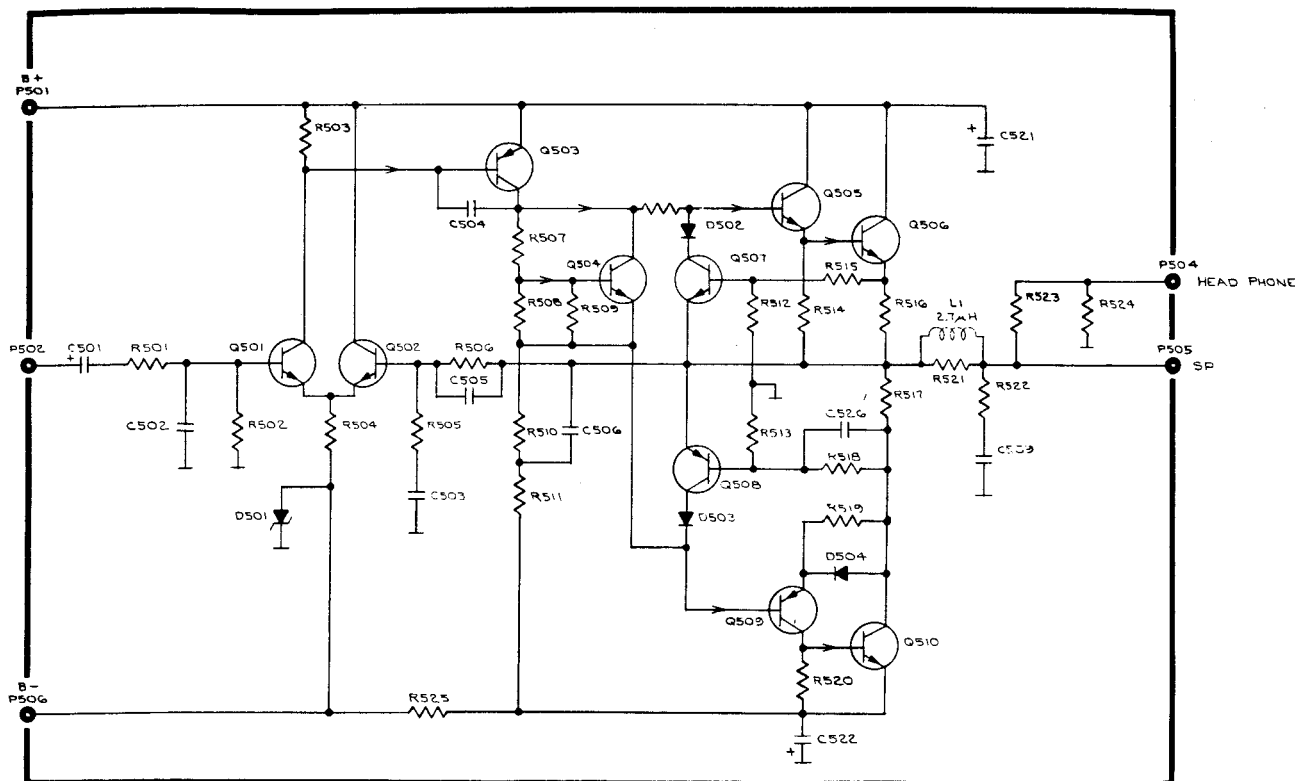

RECOMMENDED EQUIPMENT

1. AC vacuum tube voltmeter
2. DC millivolt meter or DMM
3. Oscilloscope
4. Volt-Ohm meter
5. Harmonic Distortion meter
6. AM Signal Generator
7. FM Signal Generator
8. Multiplex Generator
9. Audio Oscillator
10. Standard AM dummy antenna (200 μ F ceramic or mica capacitor)
11. Standard FM dummy antenna for 300 ohm balanced input
(see circuit, Figure FM-1)
12. Suitable alignment tools, cables, etc.
13. Two 8 ohm resistive loads, compensated for L & C (min. 100W)
14. Variable power line transformer
15. Suitable line voltage and current monitoring meters
16. Frequency counter

As an alternate to separate meters and generators, there are available, excellent combined components which are highly recommended as a substitute for audio and RF testing equipment listed above.

All tests are to be made with 120V AC line. Unless otherwise specified, supply input to both channels and read both outputs.

To simplify troubleshooting of tone and power circuits, input is connected to the Aux input with controls set as follows: (use mode switch as required)

Front Panel

Input Selector Aux
Tone Controls Flat (12 O'clock)
Loudness Minimum (full CCW)
Balance 12 O'clock
Speakers A + B

NOTE: When troubleshooting defective power circuits, it is sometimes useful to switch a small line voltage lamp in series with equipment under test before applying power. The lamp will limit the current drawn, thus preventing further damage to circuit components. The variable power line transformer is also useful to determine if additional short circuits exist, if used with a power line ampere and volt meter.

Where a standard FM antenna matching network is not available for the particular signal generator in use, a suitable network can be assembled on a small phenolic, or plastic board, using the circuit below.

The completed assembly should use short leads for connection to the receiver antenna terminals. Some generator cables may permit the circuit block to be attached directly to the cable terminals.

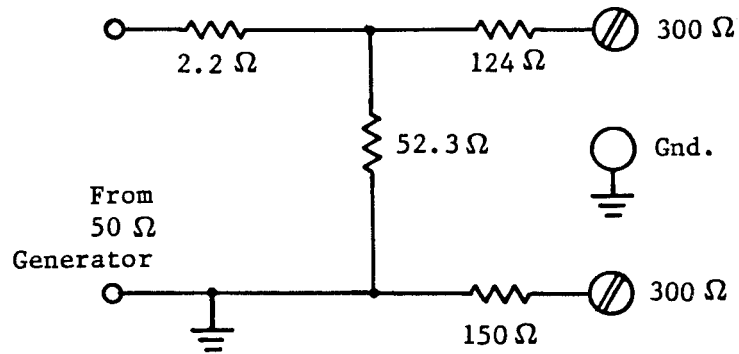

Fig. 3

Note: All resistors are 1/2 Watt, carbon composition, selected on a DVM, or Wheatstone bridge.

----- NOTICE -----

Scott Electronic Components are manufactured with a Serial No. code to identify the manufacturing plant and the year of manufacture. The following information will explain the code.

- 1) The first six digits are the unit serial number.
- 2) The first of the two letter suffix is the manufacturing plant code.
- 3) The second letter identifies the year of manufacture.
A-1975 B-1976 C-1977 D-1978 etc.

H. H. Scott, Inc. reserves the right to make changes in model design and technology without giving prior notice.

AUDIO TEST PROCEDURE

TEST	INPUT	CONTROL SETTINGS	TEST EQUIPMENT	SCALE SETTINGS	MEASURE AT		READINGS	TOL.
					POSITIVE PROBE	NEGATIVE PROBE		
DC Resistance Check	None Unit "Off"	_____	VOM	Ohms X 1000	+ Filter cap	P505 } P508 } R306/7 P807 } P804 } A406/7	6K (R306/7) 15K (A406/7)	<u>±</u> 1K
DC Resistance Check	None Unit "Off"	_____	VOM	Ohms X 10		P505 } R306/7 P508 } P807 } A406/7 P804 }	- Filter cap 40 Ω (R306/7) 50 Ω (A406/7)	<u>±</u> 1K
B+ Supply	None Unit "On"	Volume "Minimum" Selector "Aux"	VOM	Volts 60 DC	+ Filter cap	Chassis	27.5V	<u>±</u> 5%
B- Supply	Same as above	Same as above	VOM	Volts 60 DC	Chassis	- Filter cap	27.5V	<u>±</u> 5%
Regulated B+ Voltage	Same as above	Same as above	VOM	Volts 60 DC	P510 R306/7 P901 A406/7	Chassis	+13V DC	<u>±</u> 10%
Output Offset Voltage	Same as above	Same as above	VOM	12mA DC	Speaker #1 "H"	Speaker #1 "O"		<u>±</u> 4mA
			or DC Milli-voltmeter	100mV	Speaker #1 "H"	Speaker #1 "O"		<u>±</u> 100mV
Bias Check with heat-sink temp. approx. 100° F 40° C	Same as above	Same as above Adjust: R508 or R533 of R306/7; R809 or R832 of A406/7	VOM	12mA DC	Emitter of: Q506 } R306/7 Q516 } Q807 } A406/7 Q817 }	Collector of: Q510 } R306/7 Q520 } Q810 } A406/7 Q820 }	Adjust pad for 0.2mA DC nominal	+100% -0
			DC Milli-volt meter	<u>≥</u> mV DC			Adjust for 5 mV	+100% -0

AUDIO TEST PROCEDURE

TEST	INPUT	CONTROL SETTINGS	TEST EQUIPMENT	SCALE SETTINGS	MEASURE AT		READINGS	TOL.
					POSITIVE PROBE	NEGATIVE PROBE		
Audio Level 8 ohm	1000 Hz Aux.	Selector "Aux" Mode Switch "Mono" Volume "Max."	AC VTVM Scope	30V 5V/DIV	Speaker #1 "H" 8 ohm load	Speaker #1 "O" 8 ohm load	Adjust input for: 10.9V R306/7 10.9V A406/7 at outputs. Input level should be .15V. Output not clipped w/117V AC line.	With input <u>+2dB</u>
					Repeat for Speaker ---2---			
Tape Inputs	Tape In 1000 Hz	Tape Monitor Switch "Monitor"	AC VTVM	30V	Speaker #1 "H" 8 ohm load	Speaker #1 "O" 8 ohm load	Output 10.9V with input of .15V	Input <u>+2dB</u>
Tape Monitor Output	Aux	Selector "Aux" Volume "Min."	AC VTVM	1V	Tape Out	Ground	Output of .15V with input of .15V	
Frequency Response Power Amp and Tone Control	Aux	Tone Control "Flat" Volume "Max." Adjust Bal. for center	AC VTVM	1V	Speaker #1 "H" 8 ohm load	Speaker #1 "O" 8 ohm load	Adjust input for 0dB (.775V) out. (3dB down points should be below 10 Hz and above 30 kHz)	<u>+1dB</u>
Tone Control Response	Aux 1000 Hz	Selector "Aux" Mode Switch "Mono" Tone Control "Flat"	AC VTVM	1V	Speaker #1 "H" 8 ohm load	Speaker #1 "O" 8 ohm load	Adjust output for 0dB (0.78V) Note: 100 Hz Bass boost 10dB Bass cut 10dB 10 kHz Treble boost 10dB Treble cut 10dB	<u>+2dB</u>

AUDIO TEST PROCEDURE

TEST	INPUT	CONTROL SETTINGS	TEST EQUIPMENT	SCALE SETTINGS	MEASURE AT		READINGS	TOL.
					POSITIVE PROBE	NEGATIVE PROBE		
Loudness Compensation	Aux 1000 Hz 100 Hz 10 kHz ----- Increase input 20dB	Selector "Aux" Tone Control "Flat" Volume "11 O'clock" Loud Sw. "On"	AC VTVM	1V	Speaker #1 "H" 8 ohm load	Speaker #1 "O" 8 ohm load	Adjust output for 0dB. Freq. to 10 kHz; note 3dB increase. Freq. to 100 Hz note 7dB increase.	+2dB
Crosstalk	Aux Left Channel 1000 Hz	Selector "Aux" Tone Control "Flat" Loud Sw. "Off" Volume "Max." Mode Switch "Stereo"	AC VTVM	1V	Speaker #1 "H" 8 ohm load	Speaker #1 "O" 8 ohm load	Set output for 0dB. Read right channel output 45dB down	Min.
Balance Control	Aux 1000 Hz Left Channel Right Channel	Selector "Aux" Tone Control "Flat" Loud Sw. "Off" Volume "Max." Mode Switch "Mono"	AC VTVM	1V	Speaker #1 "H" 8 ohm load	Speaker #1 "O" 8 ohm load	Set output for 0dB. Rotate balance control note 45dB drop in output. Chk attenuation both channels. Change inputs.	Min.

AUDIO TEST PROCEDURE

TEST	INPUT	CONTROL SETTINGS	TEST EQUIPMENT	SCALE SETTINGS	MEASURE AT		READINGS	TOL.
					POSITIVE PROBE	NEGATIVE PROBE		
Harmonic* Distortion	Aux 20 Hz 1000 Hz 20,000 Hz	Selector "Aux" Mode Switch "Mono" Balance "Equal" Volume "Max."	AC VTVM Harmonic Distortion Analyzer	30V	Speaker #1 "H" 8 ohm load	Speaker #1 "O" 8 ohm load	Set output to 10.9V Measure distortion. 0.3% THD or less (R307/L See spec. P-2)	Max. 0.3% THD
Damping Factor	Aux 1000 Hz	Selector "Aux" Mode Switch "Mono" Balance "Center" Volume "Max."	AC VTVM	10V	Speaker #1 "H" 8 ohm load	Speaker #1 "O" 8 ohm load	Set output to 8V. Remove load & note increase in level of both channels. Max. 0.5dB	
Headphone Output	Aux 1000 Hz	Selector "Aux" Mode Switch "Mono"	AC VTVM	1V			Note level 20dB below speaker level.	+2dB

* Note: Power line Voltage 120 VAC \leq 2.0% line THD.

AM MW
TEST PROCEDURE

STEP	ANTENNA	SIGNAL GENERATOR COUPLING	SIGNAL GENERATOR FREQUENCY	INPUT SELECTOR SWITCH	DIAL SETTING	TEST INSTRUMENTS	ADJUST	REMARKS
1.	Connect external antenna terminal thru 200 pF dummy antenna.	External antenna terminal. Keep signal level low.	455 kHz 60% mod. 400 Hz	AM MW	Approx. 600 kHz (No sta.)	Scope VTVM @ Tape Output	I.F. Coil T106 (R306) T104 (R307)	Adjust for maximum signal output.
2.	Same as above	Same as above	600 kHz	Same	600 kHz	Same	AM MW Osc. T105 (R306) L14 (R307)	Adjust for calibration.
3.	Same as above	Same as above	1400 kHz	Same	1400 kHz	Same	AM MW Osc. Trimmer AM2 (R306) AM1 (R307) (F.E. assy.)	Adjust for calibration.
4.	Same as above	Same as above	1400 kHz	Same	1400 kHz	Same	MW R.F. Trimmer. AM1 (R306) AM2 (R307) (F.E. assy.)	Adjust for maximum signal.
5.	Same as above	Same as above	600 kHz	Same	600 kHz	Same	MW Antenna Slug at end of antenna.	Adjust for maximum signal.
6. Repeat steps 2, 3, 4 & 5 for maximum.								
7.	Same as step 1	300 μ V Generator output	1400 kHz 60% mod.	AM MW	1400 kHz	VTVM & Distortion Analyzer.	Detector T107 (R306) T105 (R307)	Adjust for maximum undistorted output (1% or less). Output should fall between 400 and 600 mV.

AM LW
TEST PROCEDURE

STEP	ANTENNA	SIGNAL GENERATOR COUPLING	SIGNAL GENERATOR FREQUENCY	INPUT SELECTOR SWITCH	DIAL SETTING	TEST INSTRUMENTS	ADJUST	REMARKS
8.	Same as Step 1	Same as Step 1	150 kHz	AM LW	150 kHz	Same as Step 1	AM LW Osc. L14	Adjust for calibration
9.	Same as above	Same as above	350 kHz	Same	350 kHz	Same	AM LW Osc. Trimmer	Adjust for calibration
10.	Same as above	Same as above	350 kHz	Same	350 kHz	Same	LW RF Trimmer	Adjust for max. signal
11.	Same as above	Same as above	150 kHz	Same	150 kHz	Same	LW Antenna Slug at end of antenna	Adjust for max. signal
12. Repeat steps 8, 9, 10 and 11 for maximum.								
NOTE: AM IF is aligned at the factory using sweep generator. Do not disturb coil adjustment unless replacement coils are installed. Align new coil using 5 kHz generator modulation. Adjust for maximum audio output.								

FM
TEST PROCEDURE

STEP	ANTENNA	SIGNAL GENERATOR COUPLING	SIGNAL GENERATOR FREQUENCY	INPUT SELECTOR SWITCH	DIAL SETTING	OUTPUT METER	ADJUST	REMARKS
1.	Dummy antenna Figure FM-1	External 300 ohm term. Use low signal level.	10.7 MHz 100% mod.	FM	Off Station	VTVM @ Tape Output	Front End IF T101	Adjust for maximum signal strength meter indication.
2.	Same as above	Same as above	90 MHz 1 kHz Mod. Keep gen. output low.	FM	90 MHz	Same	Front End L10 (R306) L7 (R307)	Adjust for dial calibration.
3.	Same as above	Same as above	Same	Same	90 MHz	Same	Front End L8,L9 (R306) L1,L3 (R307)	Adjust for maximum audio output. Keep signal level low.
4.	Same as above	65 dBf (1000 μ V)	Same	Same	90 MHz	Same	Quadrature Detector T102	Adjust for maximum output and minimum distortion.
5.	Same as above	External 300 ohm term. Use low signal level.	106 MHz Keep gen. output low.	Same	106 MHz	Same	TCO	Adjust for dial calibration.
6.	Same as above	Same as above	106 MHz	Same	106 MHz	Same	TCA, TCR ₁	Adjust for maximum audio output, keep input level low for noisy signal.
7.	Repeat steps 2, 3, 5 and 6 until no further improvement is noted. Check specification.							
8.	Dummy Antenna Figure FM-1	External 300 ohm term. 10 μ V	106 MHz	FM	106 MHz	VTVM @ Tape Output	VR101	Mute switch ON. Adjust VR101 so unit will mute below 10 μ V.

NOTE: Step No. 8 for R306 only.

MULTIPLEX

USE 19 kHz OUTPUT OF MX GENERATOR TO TRIGGER OSCILLOSCOPE HORIZONTAL

STEP	ANTENNA	SIGNAL GENERATOR COUPLING	SIGNAL GENERATOR FREQUENCY	INPUT SELECTOR SWITCH	DIAL SETTING	OUTPUT METER	ADJUST	REMARKS
1.	Dummy antenna Figure FM-1	External 300 ohm term.	Use convenient freq.	FM Mono	Tune to Gen.	VTVM @ Tape Output	VR103 for stationary waveform	Generator output to zero. Scope vertical to TP1 (R306) P114 (R307). Muting ON (19 kHz Osc. adj.)
2.	Same as above	Same as above	Same	FM Stereo	Same	Same		Generator output 1000 uV (65 dBf), note waveform is synchronized.
3.	Same as above	Same as above	Same	Same	Same	Same	VR102	Adjust for maximum separation.
4.	Note: Multiplex filter coils T103 & T104 in R306 and coils L101, L102, L103 and L104 in R307 are pre-aligned. Do not adjust unless circuit component is replaced. If necessary, adjust for null at specified frequency.							

DE-EMPHASIS: With output level reference at 400 Hz, switch modulation frequency to 10 kHz. Output level as follows: (+1 dB)

75 μS 13.7 dB
50 μS 9.5 dB

Note: The above procedures assume an FM Multiplex Stereo Generator, modulated with pilot. Channels are manually switched to optimize channel separation.

NOTE: To change de-emphasis from 75 μS to 50 μS, remove jumpers from Tuner PCB near C141 and C144.

SEMICONDUCTOR
OUTLINES

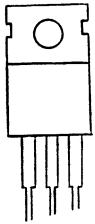

2SD 234
FT 3055

B C E

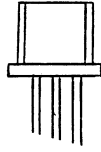

2SC 372
2SA 495
2SC 1000
2SC 733
2SC 374

E C B

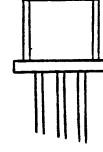

2SK 19

D S G

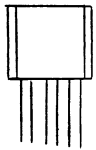
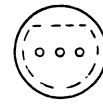

MPS A05
MPS A56

E B C

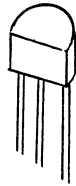

MPS 9630
MPS 9680
MPS 9633
FCS 9016
FCS 9018

E B C

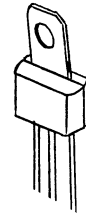

MPS U01

E B C

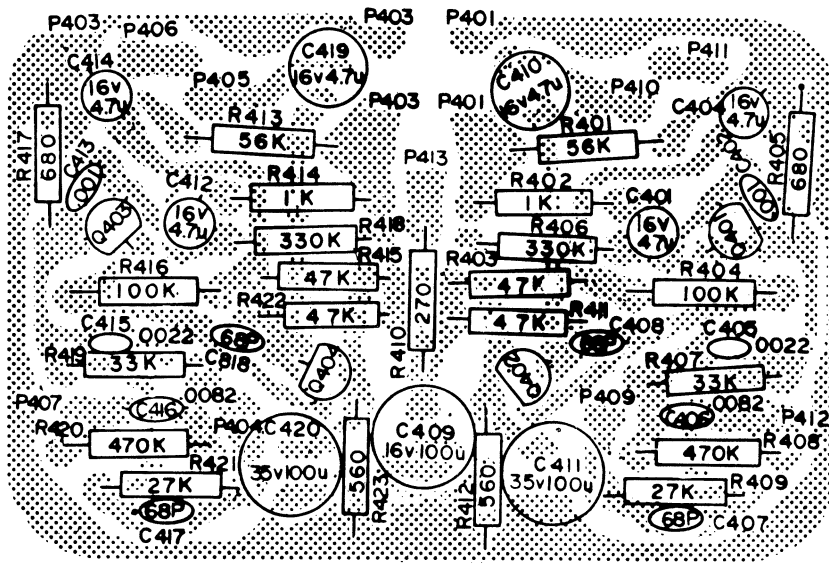

A406 PREAMP BOARD
 Assy No. 100-1333-040

A407 PREAMP BOARD
 Assy No. 100-1333-043

SEE CIRCUIT DIAGRAMS FOR DIFFERENCE IN COMPONENT VALUES

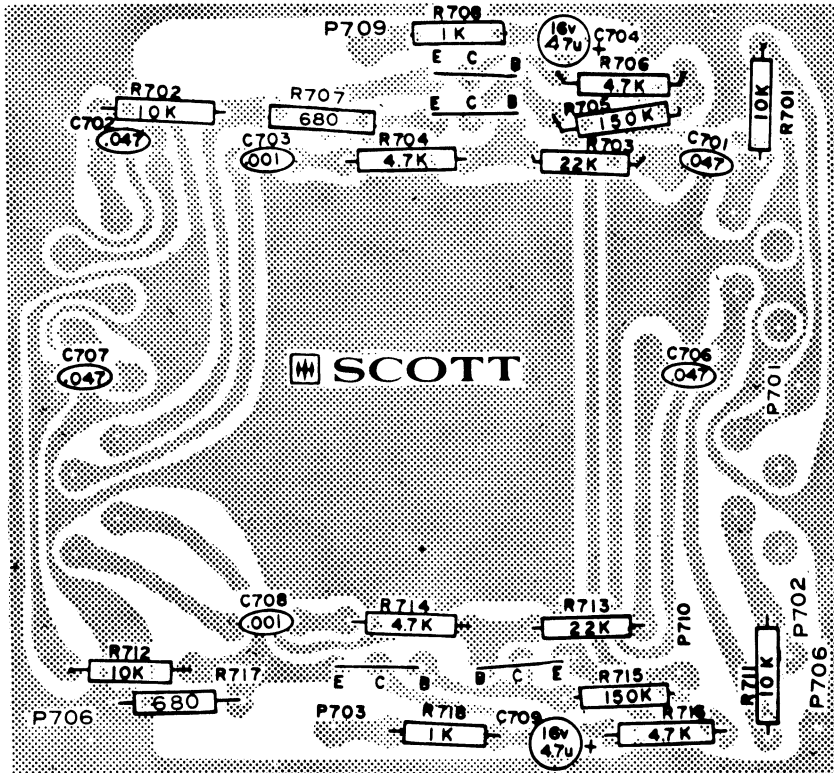

A406/A407 TONE BOARD "A"
 Assy No. 100-1334-033

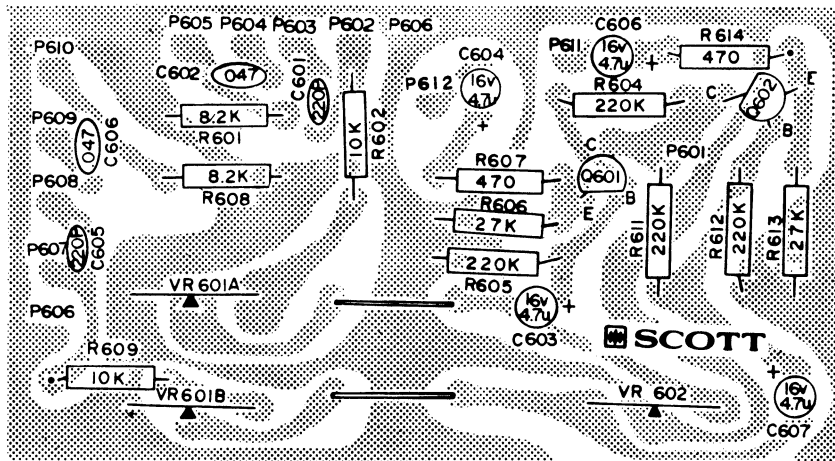

A406/A407 TONE BOARD "B"
 Assy No. 100-1334-034

SCOTT

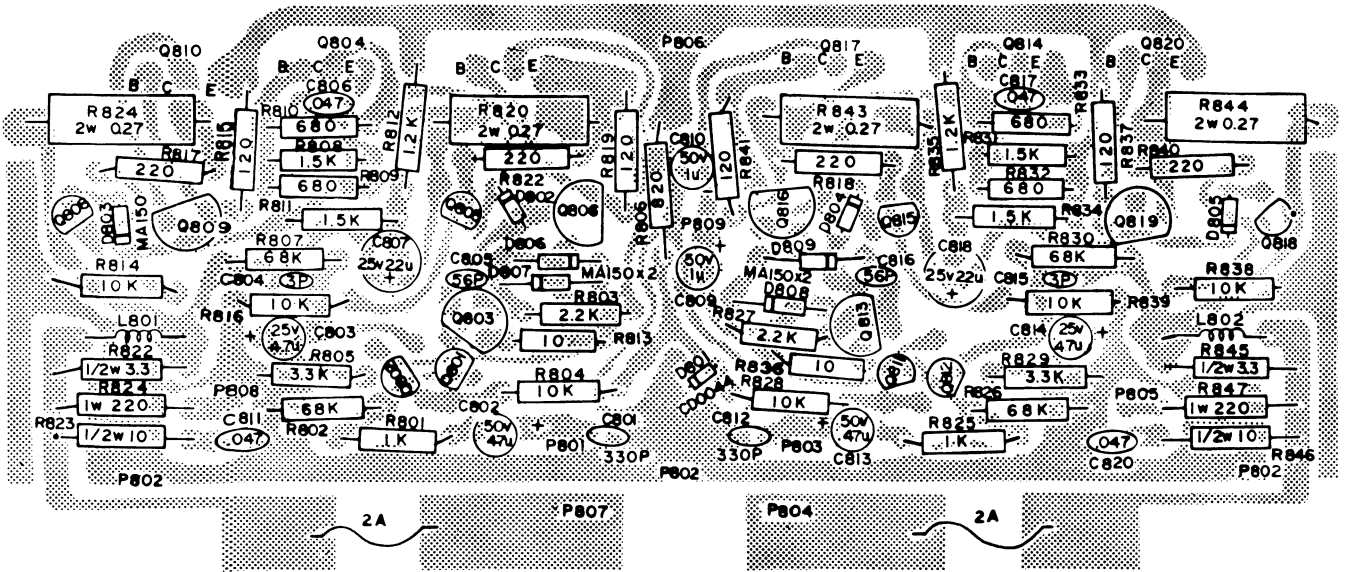

A406 DRIVER BOARD
 Assy No. 100-1335-024

A407 DRIVER BOARD
 Assy No. 100-1335-027

SEE CIRCUIT DIAGRAMS FOR DIFFERENCE IN COMPONENT VALUES

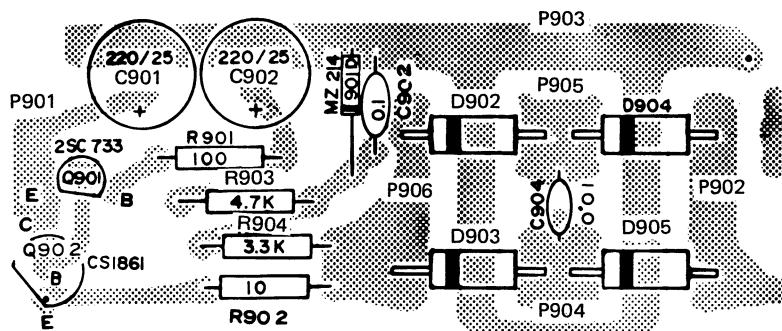

SCOTT

A406 POWER SUPPLY
 Assy No. 100-1340-044

A407 POWER SUPPLY
 Assy No. 100-1340-046

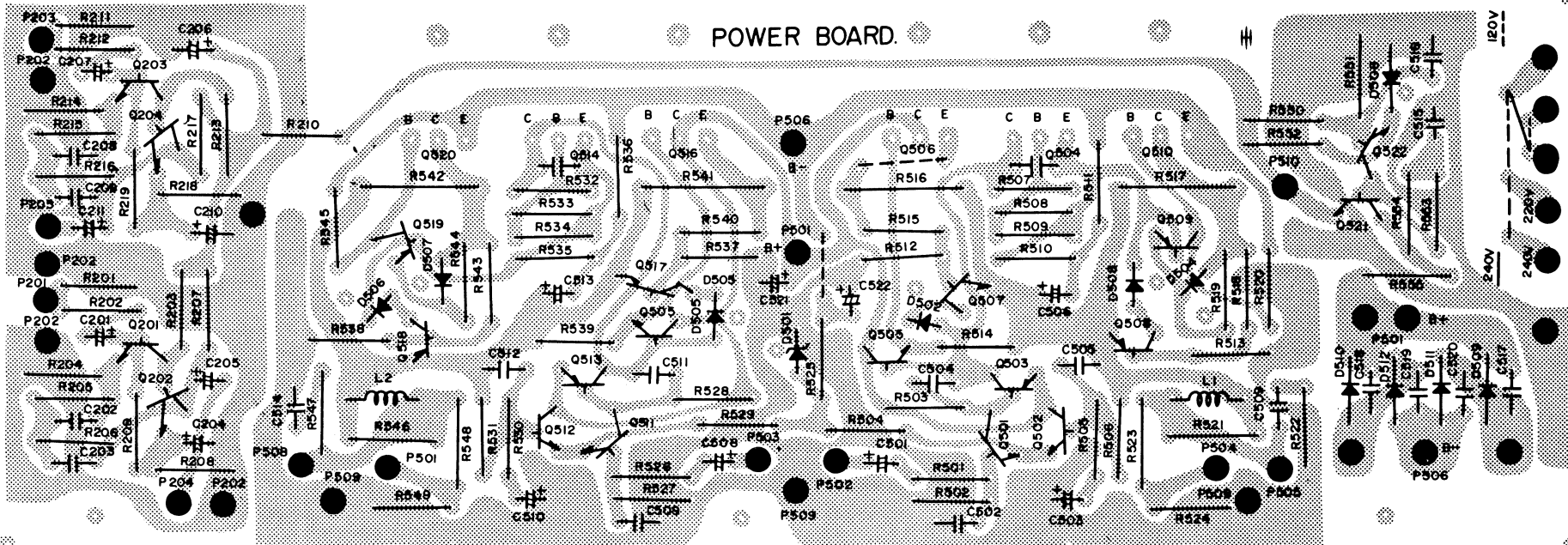

POWER BOARD.

R306 POWER AMP/PREAMP
Assy No. 100-1349-019

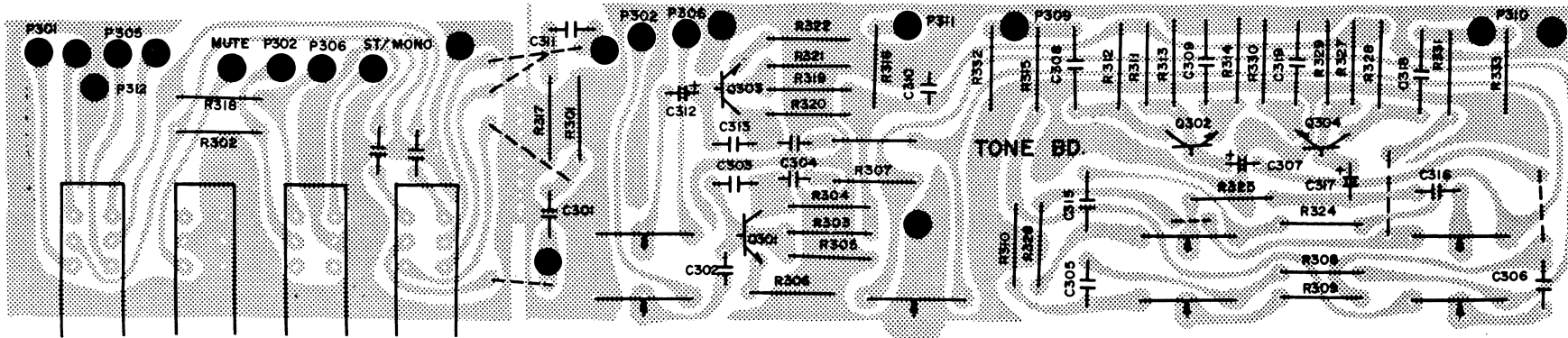

R306 PUSH SWITCH BOARD
Assy No. 100-1352-039

R306 TONE CONTROL BOARD
Assy No. 100-1334-036

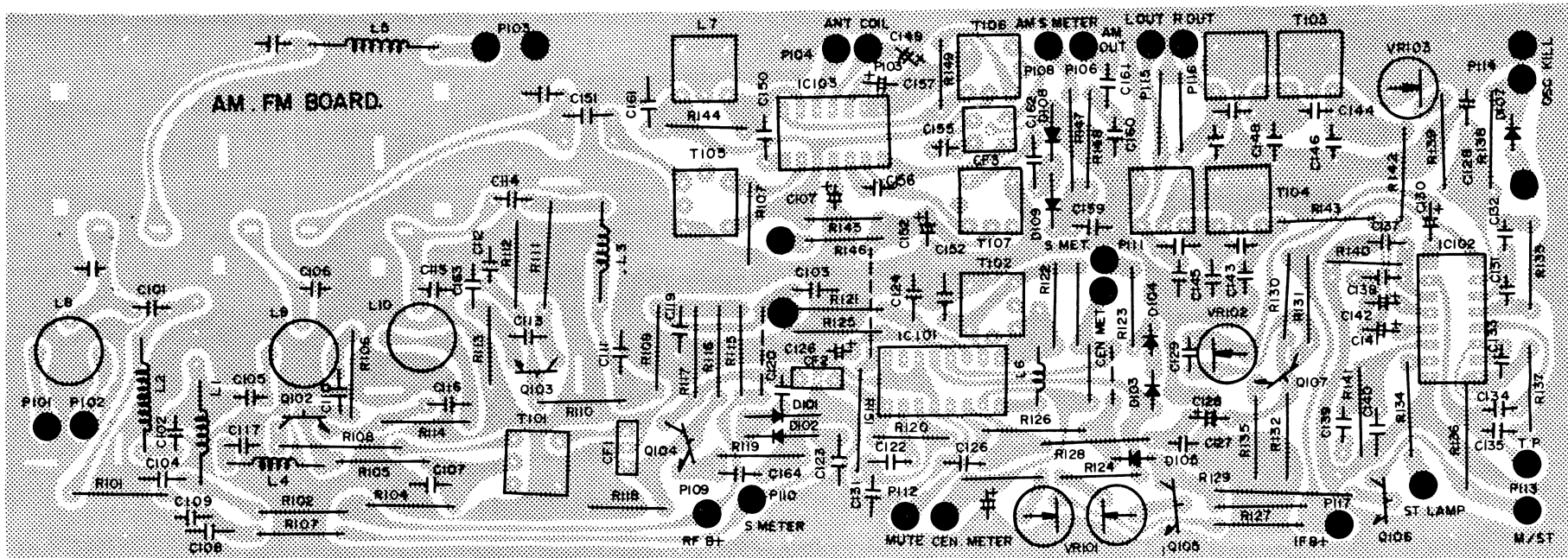

R306 TUNER BOARD
 Assy No. 100-1351-010

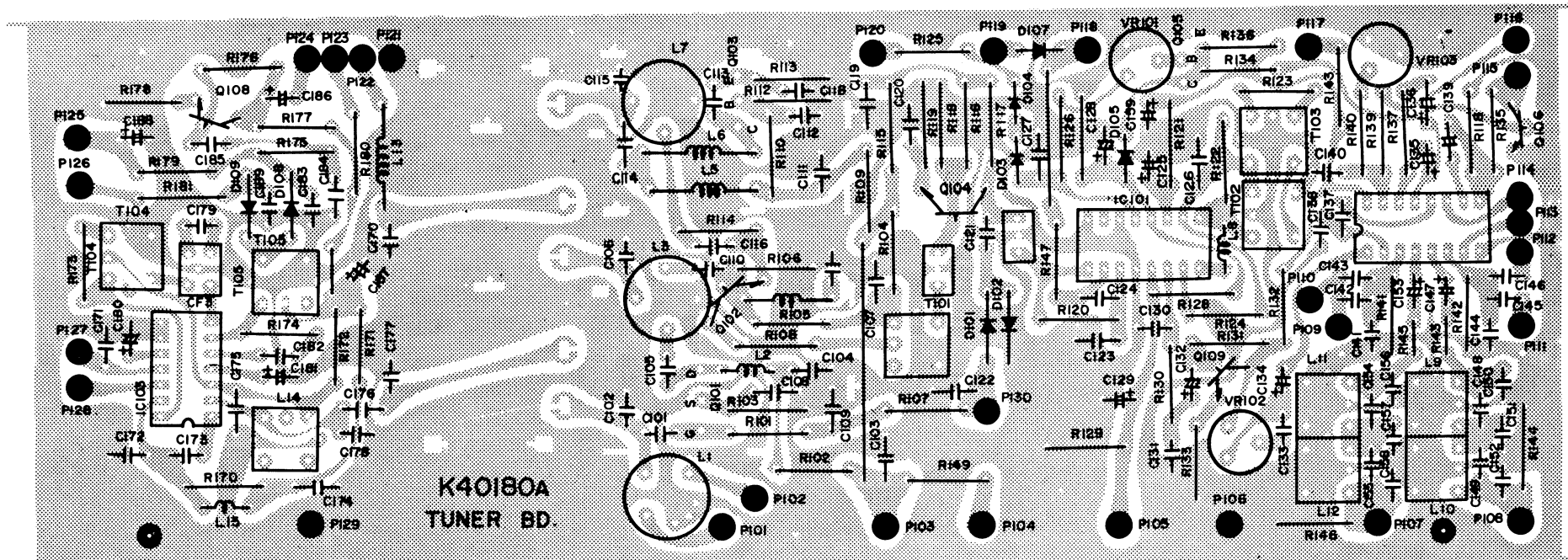

R307L TUNER BOARD (LW)
Assy No. 100-1351-014

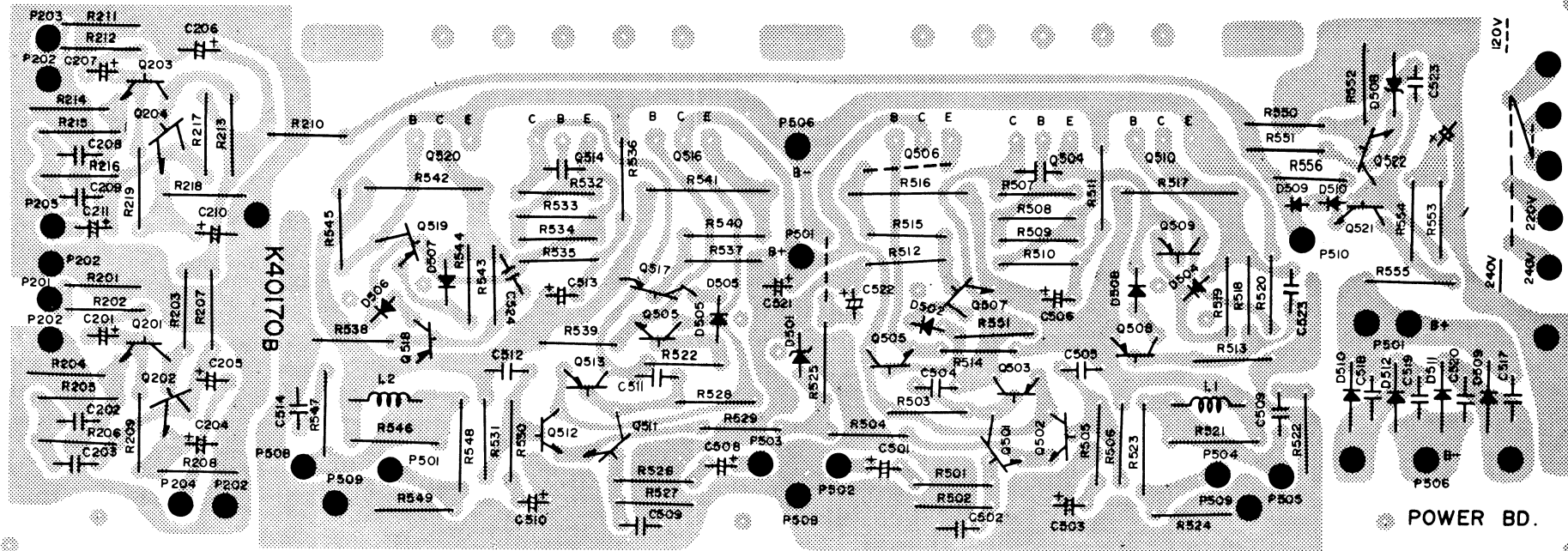

R307/R307L POWER AMP/PREAMP
 Assy No. 100-1349-020

23

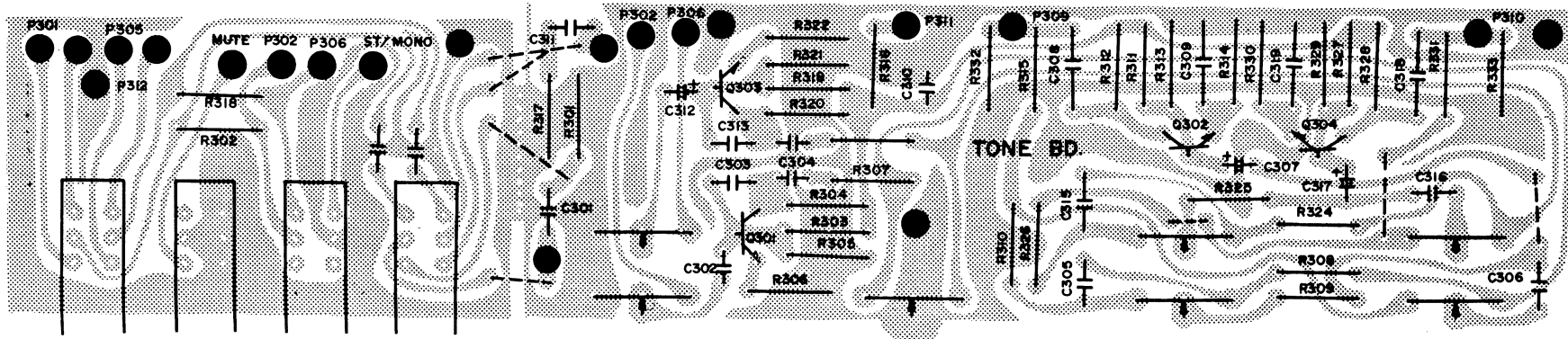

R307/R307L PUSH SWITCH BOARD
 Assy No. 100-1352-040

R307/R307L TONE BOARD
 Assy No. 100-1334-037

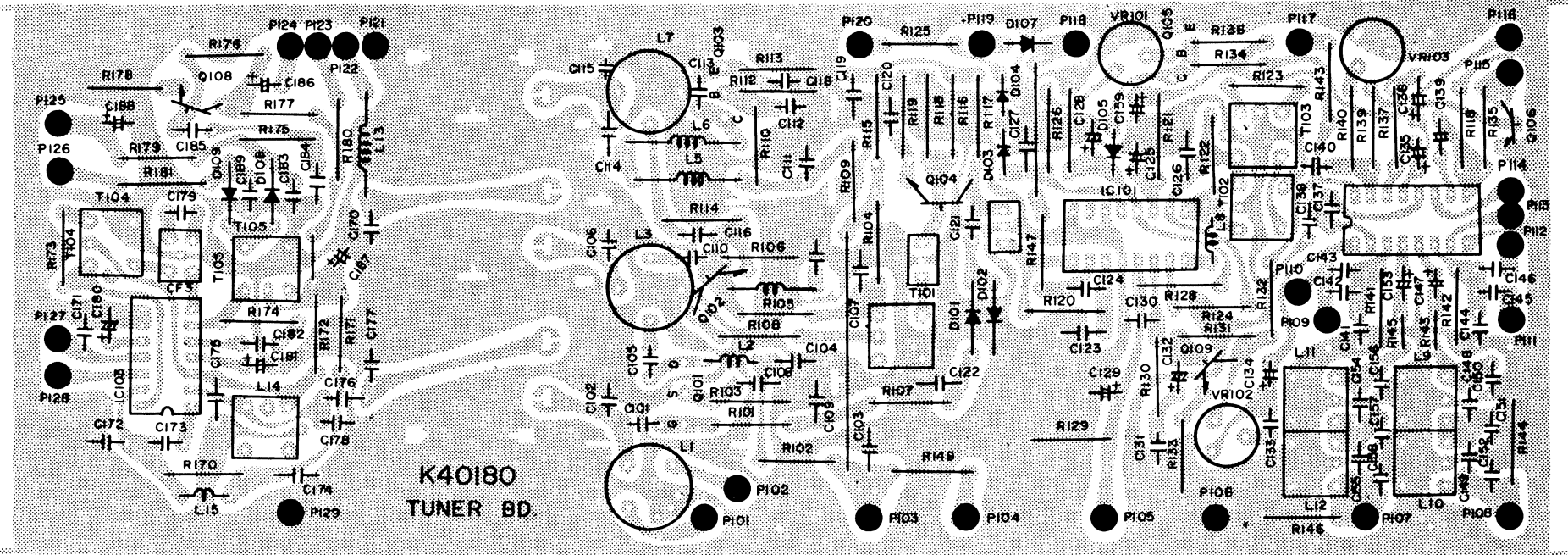

R307 TUNER BOARD (MW)
Assy No. 100-1351-011

PRODUCTION CIRCUIT CHANGES

- MODEL R307
- 1) Change regulator pass transistor from MPS A05 to FT 5321
 - 2) Production units were also built using MPS A05 (with heat sink) but with stereo indicator supplied through 1.2K. R555 changed from 10 ohm, 0.5W to 22 ohm, 0.5W.
- MODEL R306
- 1) 270 ohm resistors were added between collector of Q503 and Q513 and the base of Q505 and Q515. Add capacitor C526 and C527 for symmetrical clipping with 4 ohm loads.

SCHEMATIC DIAGRAM
Model No. R306

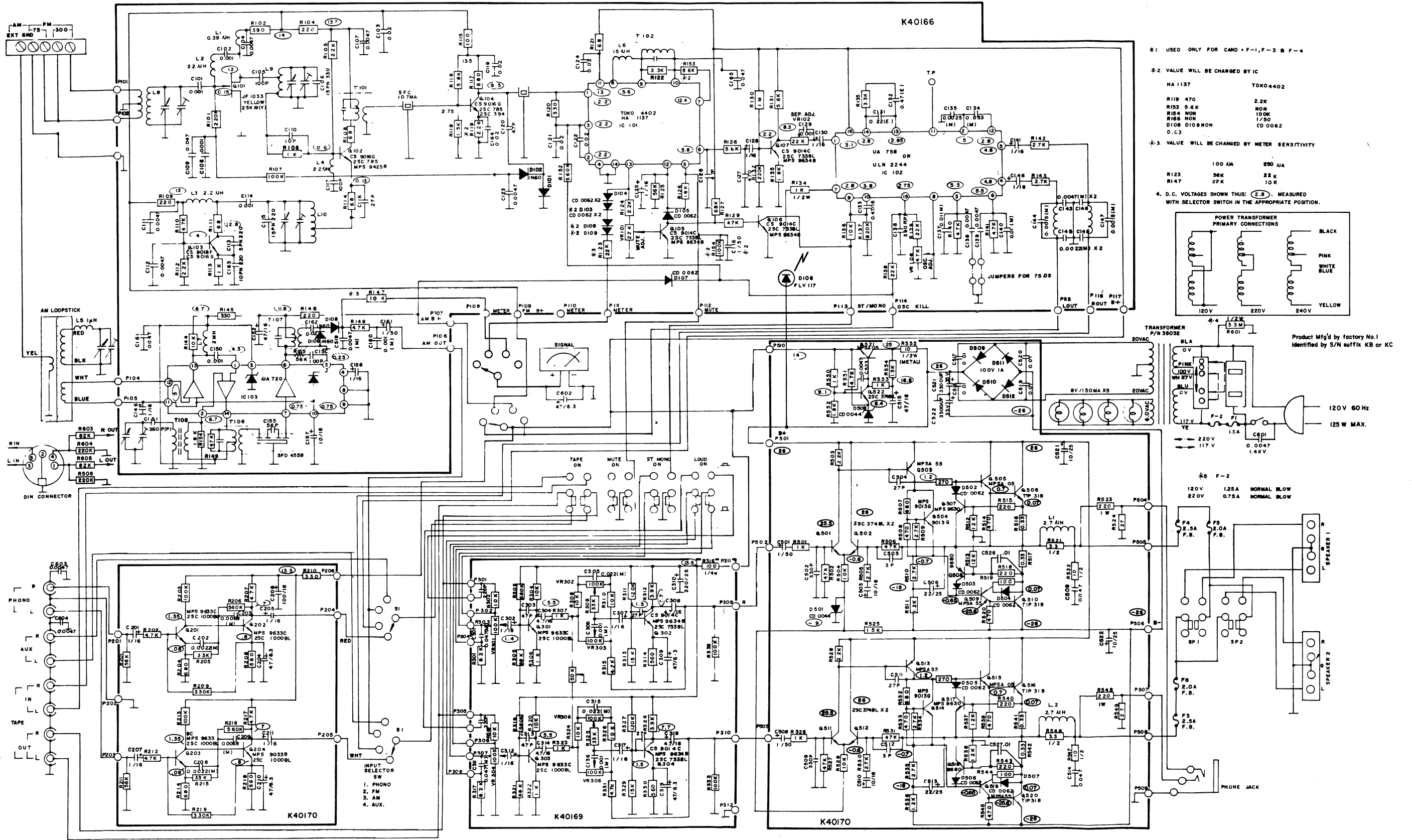

SCHEMATIC DIAGRAM
Model No. R307

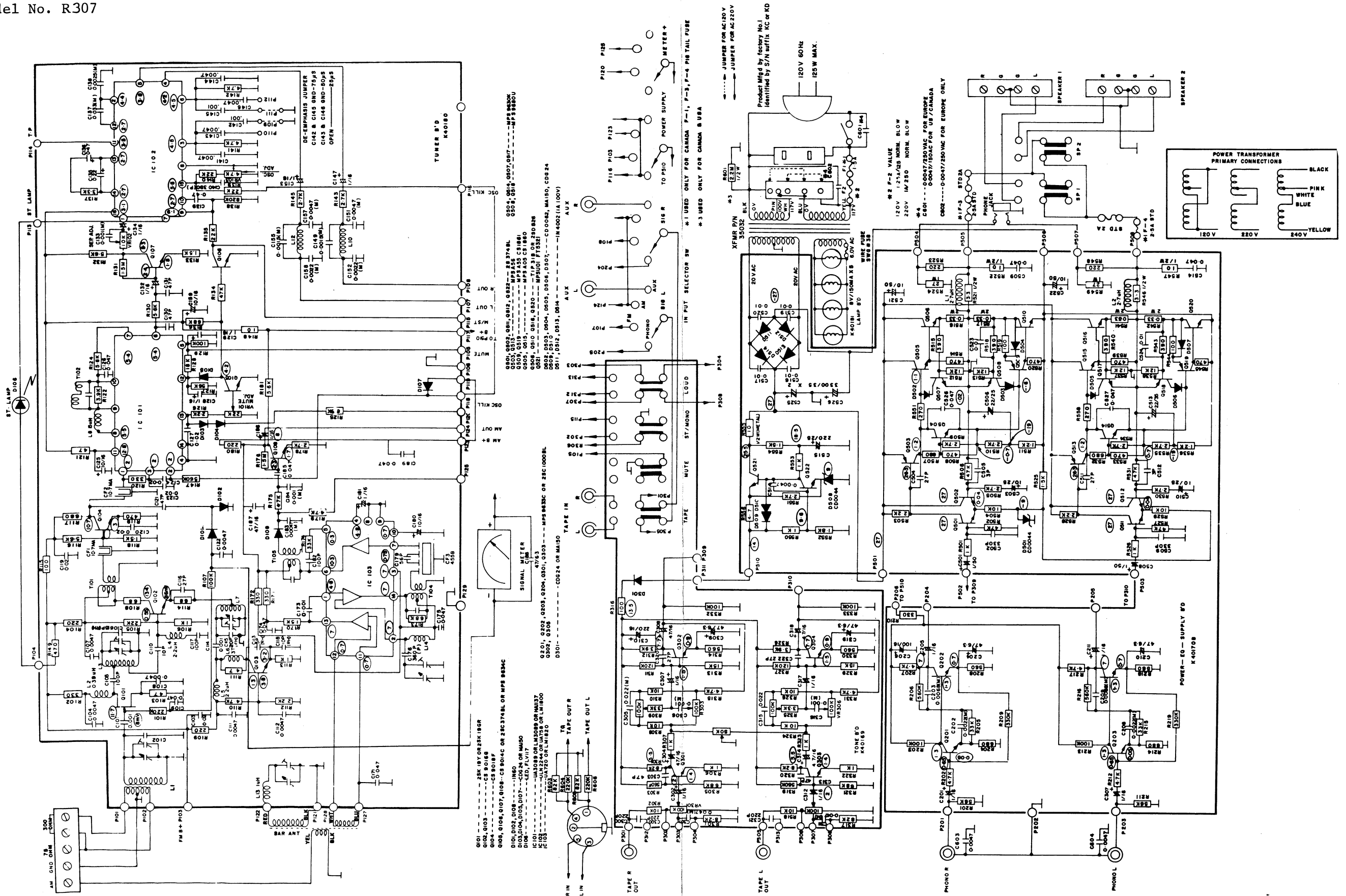

SCHEMATIC DIAGRAM
Model No. R307L

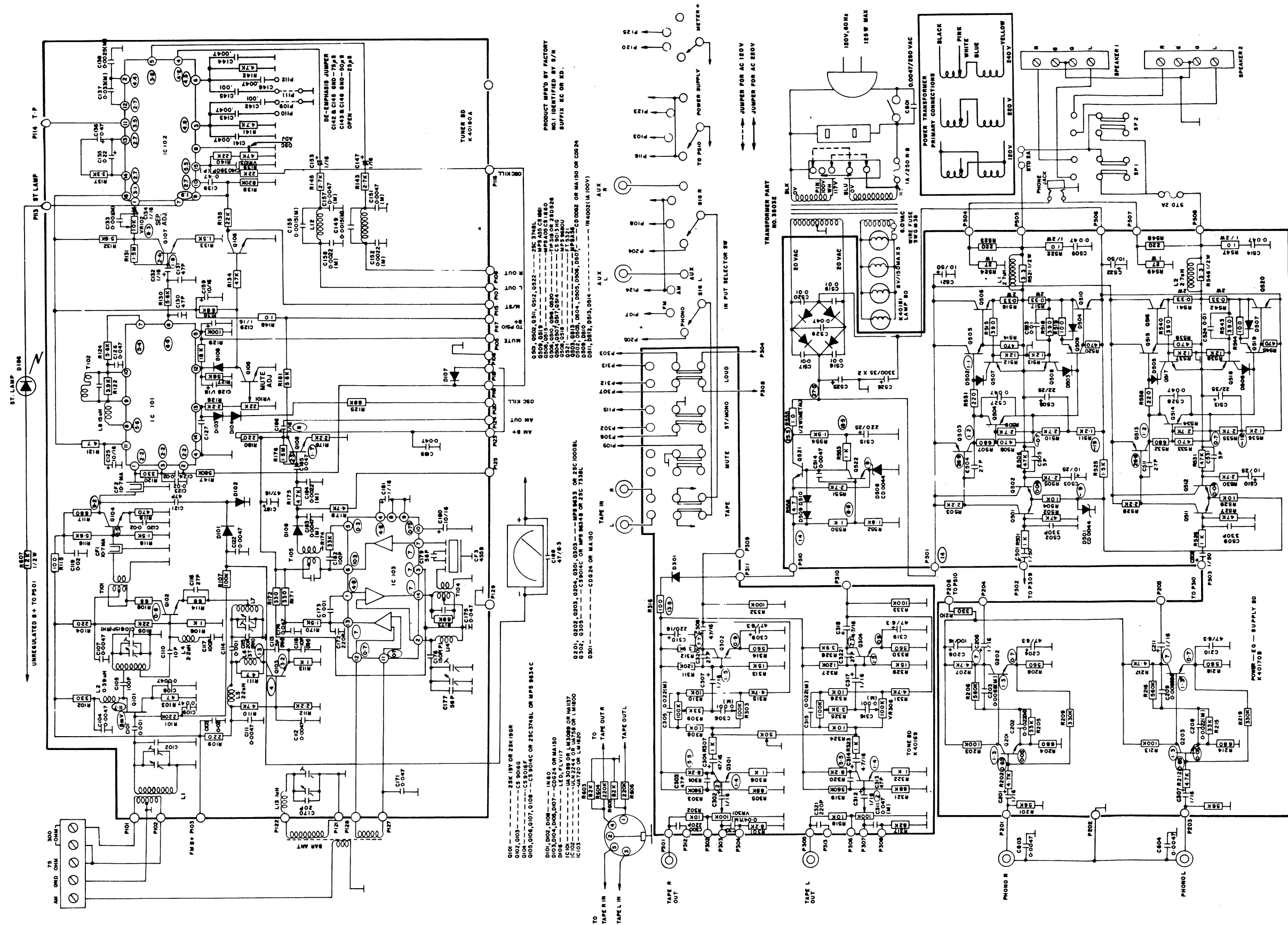

SCHEMATIC DIAGRAM
Model No. A406

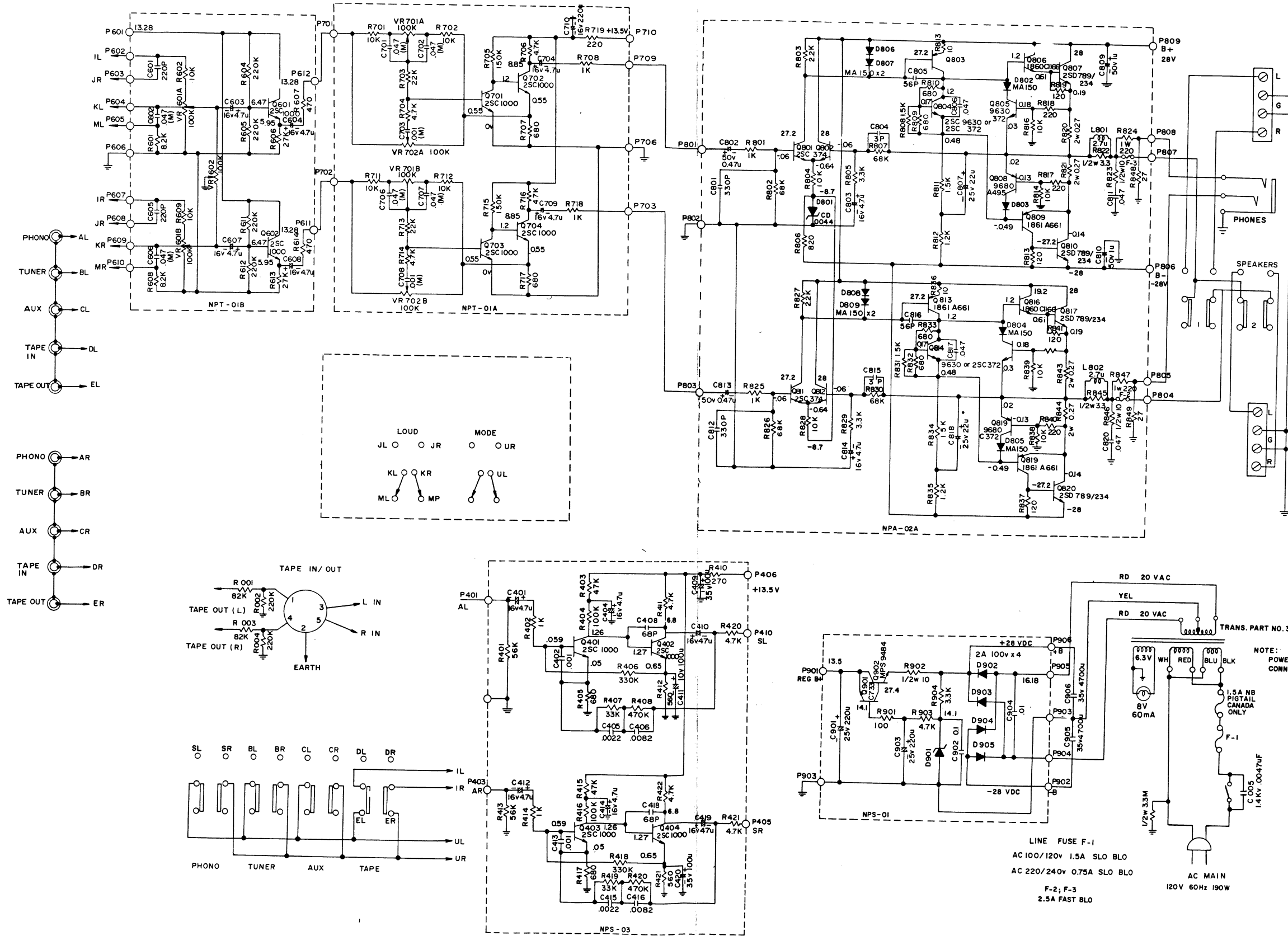

SCHEMATIC DIAGRAM
Model No. A407

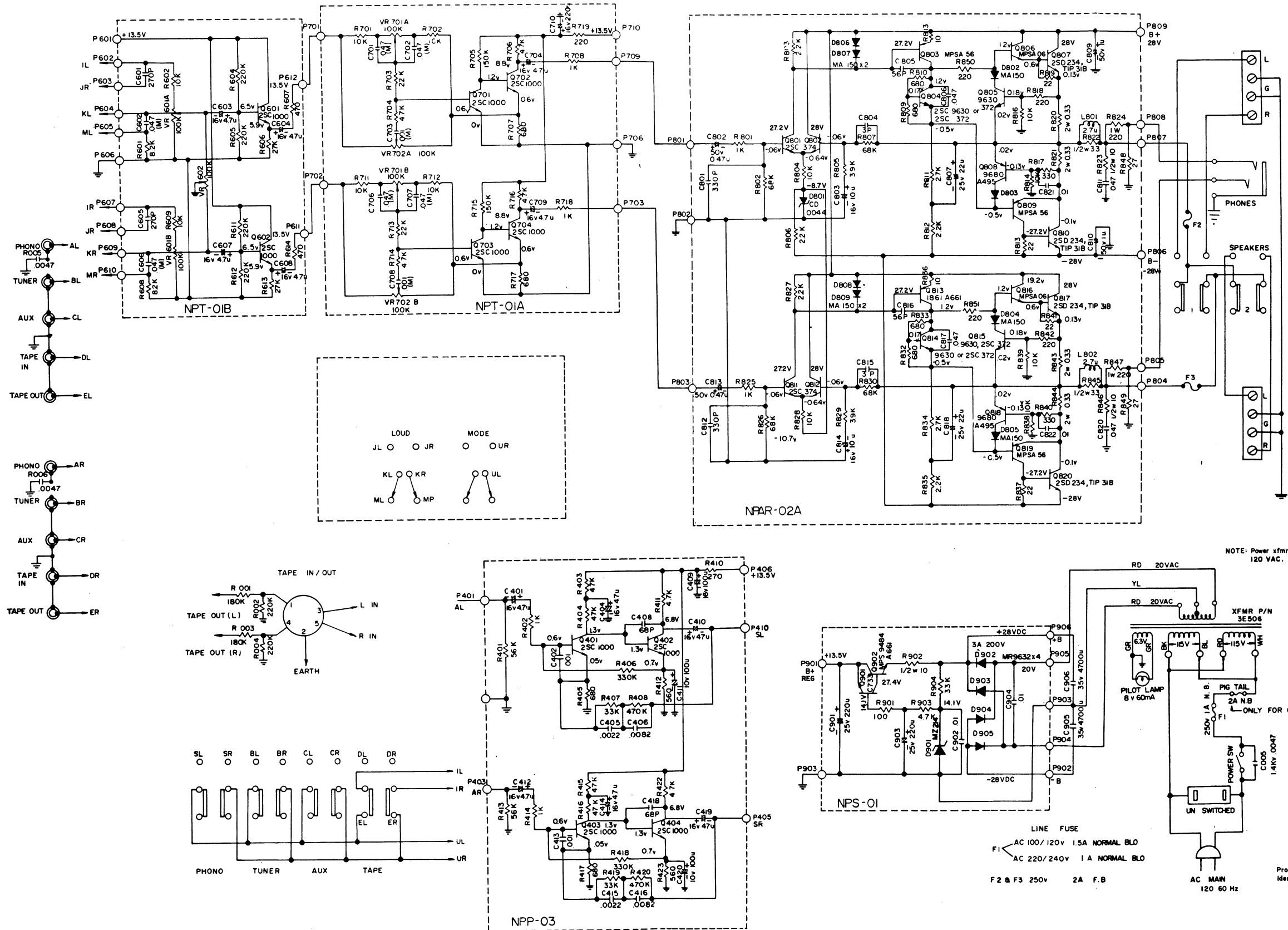

NOTE: Power xfmr shown is connected for 120 VAC.

Product Mfg'd by factory No.2 identified by suffix PC or PD

PARTS LIST

H. H. SCOTT PART NO.	DESCRIPTION	
011-1003-014	Capacitor, Tuning	R306/7
011-1004-031	Capacitor, Elect., Can 4700/35V	A406/7
011-1004-032	Capacitor, Elect., Can 3300/35V	R306/7
012-1020-004	Diode 1N 60	R306/7
012-1021-001	Diode, SI MA 150; 1N4148	A11
012-1023-009	Diode, Zener CD-0044	A11
012-1023-012	Diode, Zener MZ 214B	A406/7
012-1024-002	Diode, Rectifier 2A 100V	A406/7
012-1024-014	Diode, Rectifier 1A 100V 1N4002	R306/7
012-1018-002	Diode, Light Emitting	R306/7
015-1060-021	Jack, Input 8 Pin	R306/7
015-1060-013	Jack, Input 10 Pin	A406/7
015-1061-014	Jack, Phone	A406/7
015-1061-018	Jack, Phone	A11
015-1065-015	Jack, Din	A11
017-1095-038	Meter, Signal Strength	R306/7
018-1100-178	Knob, Volume	A406/7
018-1100-179	Knob, Control	A11
018-1100-180	Knob, Push Button	A11
018-1100-181	Knob, Lever	A406/7
018-1100-182	Knob, Slide	A406/7
018-1100-183	Knob, Tuning	R306/7
018-1102-170	Panel, Front	R306
018-1102-172	Panel, Front	A406
018-1102-177	Panel, Front	R307
018-1102-178	Panel, Front	A407
018-1105-123	Dial Scale	R306/7
020-1110-052	Transistor 2SC 733	A406/7
020-1110-053	Transistor MPS 9630; 2SC 372	A11
020-1110-054	Transistor 2SC 374	A11
020-1110-055	Transistor MPS 9680; 2SA 495	R306/7
020-1110-056	Transistor MPS A56	A11
020-1110-057	Transistor MPS A05	A11
020-1110-058	Transistor 2SC 1000	A406/7
020-1110-061	Transistor FCS 9016	R306/7
020-1110-062	Transistor MPS 9633	R306/7
020-1110-064	Transistor FCS 9018	R306/7
020-1111-051	Transistor TIP 31B	R306/7*
020-1111-058	Transistor 2SD 234	A406/7*
020-1112-008	Transistor 2SK 19; 2N 3823	R306/7

*Note: Part No. 020-1111-052 (MJE 3055T or FT 3055) is recommended for replacement in service units for part Nos. 020-1111-051 and 1-058.

PARTS LIST

H. H. SCOTT PART NO.	DESCRIPTION	
020-1114-014	Integrated Circuit FM μ A 3089	R306/7
020-1114-031	Integrated Circuit AM μ A 720	R307
020-1114-032	Integrated Circuit MX μ A 758	R306/7
021-1125-137	Potentiometer, Balance	R306/7
021-1125-139	Potentiometer, Volume	R306/7
021-1125-143	Potentiometer, Tone	R306/7
021-1125-159	Potentiometer, Volume	A406/7
021-1125-160	Potentiometer, Balance	A406/7
021-1125-161	Potentiometer, Tone	A406/7
023-1136-025	Switch, Lever	A406/7
023-1137-094	Switch, Rotary	R306/7
023-1138-059	Switch, Power	A11
023-1138-067	Switch, Push, 2 gang	R306/7
023-1138-068	Switch, Push, 4 gang	R306/7
024-1140-083	Transformer (35032)	R306/7
024-1140-087	Transformer (3E506)	A406/7
027-1157-045	Cabinet	R306/7
030-1187-037	Terminal, Antenna	R306/7
030-1187-038	Terminal, Speaker	R306/7
030-1187-039	Terminal, Speaker	A406/7
030-1189-027	Lamp, Fuse Type 8V 300mA	R307
030-1189-031	Lamp, Fuse Type 8V 150mA	R306/7
030-1189-035	Lamp, Lead Type 8V 60mA	A406/7
030-1192-010	Fuse Holder	R306/7
030-1192-015	Fuse Holder	A406/7
030-1194-008	Receptacle, AC outlet	R306/7
030-1194-010	Receptacle, AC outlet	A407
031-1198-027	Dial Pointer	R306/7
100-1333-040	Assy., Preamp	A406
100-1333-043	Assy., Preamp	A407
100-1334-033	Assy., Tone "A"	A406/7
100-1334-034	Assy., Tone "B"	A406/7
100-1334-036	Assy., Tone	R306
100-1334-037	Assy., Tone	R307
100-1335-024	Assy., Driver	A406
100-1335-027	Assy., Driver	A407
100-1340-044	Assy., Power Supply	A406
100-1340-046	Assy., Power Supply	A407
100-1349-019	Assy., Power Amp-Preamp	R306
100-1349-020	Assy., Power Amp-Preamp	R307
100-1351-010	Assy., Tuner	R306
100-1351-011	Assy., Tuner	R307
100-1352-039	Assy., Push Switch	R306
100-1352-040	Assy., Push Switch	R307

USEFUL INFORMATION

dBf to Microvolt

Table - - - 300 ohms

MICROVOLTS	DBF	MICROVOLTS	DBF
1	5.228	5.5	20.03
1.1	6.056	6	20.79
1.2	6.812	6.5	21.48
1.3	7.507	7	22.13
1.4	8.151	7.5	22.73
1.5	8.750	8	23.29
1.6	9.311	8.5	23.81
1.7	9.837	9	24.31
1.8	10.33	9.5	24.78
1.9	10.80	10	25.22
2	11.24	10.5	25.62
2.1	11.67	11	26.05
2.2	12.07	11.5	26.44
2.3	12.46	12	26.81
2.4	12.83	12.5	27.16
2.5	13.18	13	27.50
2.6	13.52	13.5	27.83
2.7	13.85	14	28.15
2.8	14.17	14.5	28.45
2.9	14.47	15	28.75
3	14.77	15.5	29.03
3.1	15.05	16	29.31
3.2	15.33	16.5	29.57
3.3	15.59	17	29.83
3.4	15.85	17.5	30.08
3.5	16.11	18	30.33
3.6	16.35	18.5	30.57
3.7	16.59	19	30.80
3.8	16.82	19.5	31.02
3.9	17.05	20	31.24
4	17.26	20.5	31.46
4.1	17.48	21	31.67
4.2	17.69	21.5	31.87
4.3	17.89	22	32.07
4.4	18.09	22.5	32.27
4.5	18.29	23	32.46
4.6	18.48	23.5	32.65
4.7	18.67	24	32.83
4.8	18.85	24.5	33.01
4.9	19.03	25	33.18
5	19.20	26	33.52

MICROVOLTS	DBF	MICROVOLTS	DBF
27	33.85	76	42.84
28	34.17	77	42.95
29	34.47	78	43.07
30	34.77	79	43.18
31	35.05	80	43.29
32	35.33	81	43.39
33	35.59	82	43.50
34	35.85	83	43.61
35	36.11	84	43.71
36	36.35	85	43.81
37	36.59	86	43.91
38	36.82	87	44.01
39	37.05	88	44.11
40	37.26	89	44.21
41	37.48	90	44.31
42	37.69	91	44.40
43	37.89	92	44.50
44	38.09	93	44.59
45	38.29	94	44.69
46	38.48	95	44.78
47	38.67	96	44.87
48	38.85	97	44.96
49	39.03	98	45.05
50	39.20	99	45.14
51	39.38	100	45.22
52	39.54	101	45.31
53	39.71	102	45.40
54	39.87	103	45.48
55	40.03	104	45.56
56	40.19	105	45.65
57	40.34	106	45.73
58	40.49	107	45.81
59	40.64	108	45.89
60	40.79	109	45.97
61	40.93	110	46.05
62	41.07	111	46.13
63	41.21	112	46.21
64	41.35	113	46.29
65	41.48	114	46.36
66	41.61	115	46.44
67	41.75	116	46.51
68	41.87	117	46.59
69	42.00	118	46.66
70	42.13	119	46.73
71	42.25	120	46.81
72	42.37	121	46.88
73	42.49	122	46.95
74	42.61	123	47.02
75	42.73	124	47.09
		125	47.16