

**SERVICE MANUAL**  
**stereo components**

**A417**

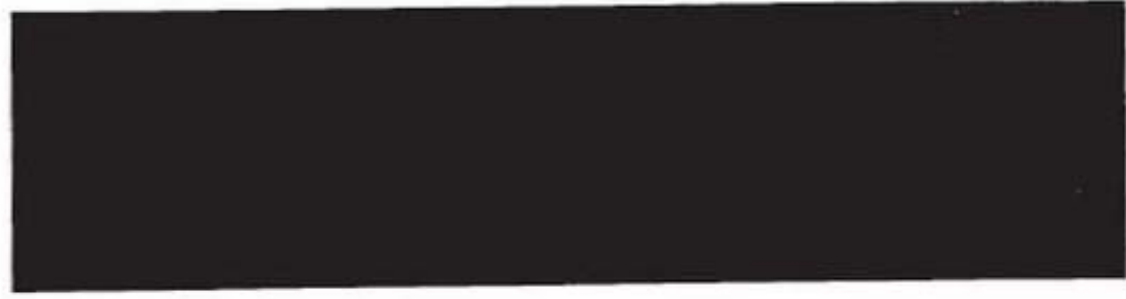

**A437**



**A457**



 **SCOTT**<sup>®</sup>

**The Name to listen to.**

H. H. SCOTT, INC., 20 Commerce Way, Woburn, Mass. 01801, Tel. 617 933-8800

-----NOTICE-----

The following safety precautions must be followed to assure continued reliability and safety against fire and shock hazard:

- 1.) Replacement parts used during servicing of this appliance must have identical characteristics as those offered and recommended by H. H. Scott, Inc.
- 2.) Satisfactory and approved service procedures dictate that ALL PARTS, no matter how apparently unimportant, be replaced exactly as in the original design.  
EXAMPLES:
  - a) Braided glass tubing over resistors.
  - b) Heatsinks on transistors.
  - c) Ceramic tube spacers.
  - d) All mechanical parts, i.e. covers, brackets, screws etc.
- 3.) A dielectric test is to be performed on each appliance following the re-assembly and before returning the unit to the customer.

4.) The dielectric test, to be performed on H. H. Scott, Inc. electronic components serviced in the U. S. and Canada for use in these countries, shall consist of not less than the following:\*

- 1.) A dielectric tester designed to supply not less than 1100 volts at 60 Hz and employing leakage current indicator/s is to be used.
- 2.) The tester is to be connected per the instructions enclosed with the instrument, or as follows:
  - a) The tester is connected to the power line receptacle, and the power switch is turned ON.
  - b) Sufficient time is allowed for the tester supply to stabilize and then the output voltage is adjusted for 1080 volts.
  - c) Leads of the tester, usually marked GND and HV, are connected between chassis GND and both blades of the male plug of the power cord.
  - d) Switch tester to "test" and observe leakage indicator.  
LEAKAGE CURRENT MUST NOT EXCEED 0.5 mA.

\* Dielectric tests made by service personnel in countries other than United States and Canada must use test equipment and procedures specified by the safety agency serving that country.

EQUIPMENT SPECIFICATIONS

	A417	A437	A457
*Power Output	25 Watts	42 Watts	60 Watts
Max. THD @ rated output	0.3%	0.3%	0.2%
Max. IMD @ rated output	0.3%	0.15%	0.1%
Input Sensitivity - Phono	2.5 mV	2.5 mV	2.5 mV
- Mic	6.0 mV	6.0 mV	6.0 mV
- Aux	160 mV	160 mV	160 mV
- Tuner	160 mV	160 mV	160 mV
Signal - Noise Ratio, weighted (input shorted)	70 dB	75 dB	75 dB
- Phono	75 dB	80 dB	80 dB
- Mic	80 dB	85 dB	85 dB
- Aux	80 dB	85 dB	85 dB
- Tuner	80 dB	85 dB	85 dB
- Tape	80 dB	85 dB	85 dB
Frequency Response @ 1 Watt (+1 dB)	20 Hz-20 kHz	20 Hz-20 kHz	20 Hz-20 kHz
- Phono	16 Hz-32 kHz	15 Hz-35 kHz	15 Hz-35 kHz
- Aux	47,000 ohms	47,000 ohms	47,000 ohms
Input Impedance	60,000 ohms	60,000 ohms	60,000 ohms
- Phono	42 dB	42 dB	42 dB
- Aux	46 dB	46 dB	46 dB
Separation	35	35	35
Damping Factor			

POWER REQUIREMENTS

Line Voltage	120V AC	120V AC	120V AC
Frequency	60 Hz	60 Hz	60 Hz
Power Consumption - Full load	190 Watts	360 Watts	420 Watts
- Idle	8 Watts	12 Watts	12 Watts

WEIGHT

Net Weight	15 lbs. 6.8 kg	20 lbs. 9.2 kg	23 lbs. 10.2 kg
Shipping Weight	16.2 lbs. 7.4 kg	23.5 lbs. 10.6 kg	26.5 lbs. 12 kg

\*Per H. H. Scott, Inc. output power statement as required by the Federal Trade Commission.

## RECOMMENDED EQUIPMENT

1. AC Vacuum tube voltmeter
2. DC millivolt meter or DMM
3. Oscilloscope
4. Volt-Ohm meter
5. Harmonic Distortion meter
6. Audio Oscillator
7. Suitable tools, cables, etc.
8. Two 8 ohm resistive loads, compensated for L & C (min. 100W)
9. Variable power line transformer
10. Suitable line voltage and current monitoring meters

As an alternate to separate meters and generators, there are available, excellent combined components which are highly recommended as a substitute for audio testing equipment listed above.

All tests are to be made with 120V AC line. Unless otherwise specified, supply input to both channels and read both outputs.

To simplify troubleshooting of tone and power circuits, input is connected to the Aux input, with controls set as follows: (use mode switch as required)

### Front Panel

Input Selector . . . . .	Aux
Tone Controls . . . . .	Flat ("0")
Loudness . . . . .	Minimum (full CCW)
Balance . . . . .	12 O'clock
Speakers . . . . .	A + B (1 + 2)

NOTE: When troubleshooting defective power circuits, it is sometimes useful to switch a small line voltage lamp in series with equipment under test before applying power. The lamp will limit the current drawn, thus preventing further damage to circuit components. The variable power line transformer is also useful to determine if additional short circuits exist, if used with a power line ampere and volt meter.

### ----- NOTICE -----

Scott Electronic Components are manufactured with a serial number code to identify the manufacturing plant and the year of manufacture. The following information will explain the code.

- 1) The first six digits are the unit serial number.
- 2) The first of the two letter suffix is the manufacturing plant code.
- 3) The second letter identifies the year of manufacture.

A-1975 B-1976 C-1977 D-1978 etc.

H. H. Scott, Inc. reserves the right to make changes in model design and technology without giving prior notice.

AUDIO TEST PROCEDURE A417 AND A437  
Serial No. SUFFIX PC OR PD

TEST	INPUT	CONTROL SETTINGS	TEST EQUIPMENT	SCALE SETTINGS	MEASURE AT		READINGS	TOL.
					POSITIVE PROBE	NEGATIVE PROBE		
DC Resistance Check	None Unit "Off"		VOM	Ohms X 1000	+ Filter cap	P807 } P804 } A417 P305 } P306 } A437	15K A417 8K A437 Measure	+1K
DC Resistance Check	None Unit "Off"		VOM	Ohms X 10	P807 } P804 } A417 P305 } P306 } A437	- Filter cap	40 Ohms	+1K
B+ Supply	None Unit "On"	Volume "Minimum" Selector "Aux"	VOM	Volts 60 DC	+ Filter cap	Chassis	31.5V DC A417 38.0V DC A437	+5%
B- Supply	None Unit "On"	Same as Above	VOM	Volts 60 DC	Chassis	- Filter cap	-31.5V DC A417 -38.0V DC A437	+5%
Regulated B+ Voltage	Same	Same	VOM	Volts 60 DC	P901 A417 P311 A437 Supply Board	Chassis	+13V DC A417 +15V DC A437	+10%
Output Offset Voltage	Same	Same	VOM	12mA DC	Speaker A (1) "L" or "R"	Speaker A (1) "C"	+1.25 mA	Max.
			DC Milli-voltmeter	100mV	Speaker A "L" or "R"	Speaker A "C"	+25 mV	Max.
Bias Check	Same	Same Adjust R809 or R832-A417 R323 or R324 in A437 or adjust bias pot if pro- vided.	VOM	12mA DC	Emitter of: Q807 } Q817 } A417 Q17 } Q18 } A437	Collector of: Q810 } Q820 } A417 Q19 } Q20 } A437	Adjust pad for 0.2mA DC nomi- nal.	+100% -0
			DMM	mV	Emitter of: Same as above	Collector of: Same as above	5mV	+100% -0



AUDIO TEST PROCEDURE A417 AND A437  
Serial No. SUFFIX PC OR PD

TEST	INPUT	CONTROL SETTINGS	TEST EQUIPMENT	SCALE SETTINGS	MEASURE AT		READINGS	TOL.
					POSITIVE PROBE	NEGATIVE PROBE		
Audio Level 8 Ohm	1000 Hz Aux	Selector "Aux" Mode Switch "Mono" Volume "Maximum"	AC VTVM Scope	30V 5V/DIV	Speaker A (1) "L" or "R" 8 ohm load	Speaker A (1) "G" 8 ohm load	Adjust input for: 14.1V A417 18.3V A437 at outputs. Input level should be 0.15V. Output not clipped w/120V AC line.	w/input +2dB
					Repeat for speaker ----B---- (2)			
Tape Inputs	Tape In 1000 Hz	Tape Monitor Switch "Monitor"	AC VTVM	30V	Speaker A "L" or "R" 8 ohm load	Speaker A "G" 8 ohm load	Output: 14.1V A417 18.3V A437 w/input of .15 Volt	Input +2dB
Tape Monitor Output	Aux	Selector "Aux" Volume "Minimum"	AC VTVM	1V	Tape Out	Ground	Output of .15V w/input of .15V	
Mode Switch A437 Only L & R L R Stereo Rev. Stereo	Aux L 0.025V " " " " "	Volume "Maximum"	AC VTVM	1V	Speaker A "R" Right Channel	Speaker A "G" Right Channel	Output level 0 dB 0 dB both chan. 0 dB both chan. No output 0 dB L chan. 0 dB R chan.	
Frequency Response Power Amp & Tone Control	Aux	Tone Control "0" Volume "Maximum" Balance "Center"	AC VTVM	1V	Speaker A "L" or "R" 8 ohm load	Speaker A "G" 8 ohm load	Adjust input 0 dB (.775V) out. (3 dB down points should be below 10 Hz and above 30 kHz)	

AUDIO TEST PROCEDURE A417 AND A347  
Serial No. SUFFIX PC OR PD

TEST	INPUT	CONTROL SETTINGS	TEST EQUIPMENT	SCALE SETTINGS	MEASURE AT		READINGS	TOL.
					POSITIVE PROBE	NEGATIVE PROBE		
Tone Control Response	Aux 1000 Hz	Selector "Aux" Mode Switch "Mono" Tone Control "0"	AC VTVM	1V	Speaker A (1) "L" or "R" 8 ohm load	Speaker A (1) "G" 8 ohm load	Adjust output for 0 dB (.78V) Note: 100 Hz Bass Boost 10 dB Bass cut 10 dB 10 kHz Treble boost 10 dB Treble Cut 10 dB	+2dB
Loudness Compensation	Aux 1000 Hz 100 Hz 10 kHz ----- Increase input 20 dB	Selector "Aux" Tone Control "0" Volume "11 O'clock" Loud Switch "On"	Same	Same	Speaker A "L" or "R" 8 ohm load	Speaker A "G" 8 ohm load	Adjust output for 0 dB. Freq. to 10 kHz; Note 3 dB increase. Freq. to 100 Hz; Note 7 dB increase.	+2dB  +2dB
Crosstalk	Aux Left Channel 1000 Hz	Selector "Aux" Tone Control "0" Loud Switch "Off" Volume "Max" Mode Switch "Stereo"	Same	Same	Speaker A "L" 8 ohm load	Speaker A "G" 8 ohm load	Set output for 0 dB. Read right channel output 45 dB down.	Min.
High & Low Filter A437 Only	1 kHz 100 Hz 10 kHz	Selector "Aux" Mode Switch "Mono"	AC VTVM	1V	Speaker A "L" or "R"	Speaker A "G"	Max. 1 dB change @1 kHz Low Filter -8 dB @ 100 Hz High Filter -3 dB @ 10 kHz	+2dB

AUDIO TEST PROCEDURE A417 AND A437  
Serial No. SUFFIX PC OR PD

TEST	INPUT	CONTROL SETTINGS	TEST EQUIPMENT	SCALE SETTINGS	MEASURE AT		READINGS	TOL.
					POSITIVE PROBE	NEGATIVE PROBE		
Meters A437	Aux 1 kHz	Mono	AC VTVM	30V	Speaker A "L" or "R"	Speaker A "G"	W/output level at 18.3V both channels, Amplifier in normal operating position. Check & set meters for 100% reading. Check for app. $\frac{1}{2}$ scale meter indication with 0.36V output.	+2dB
Balance Control	Aux 1000 Hz Left Channel Right Channel	Selector "Aux" Tone Control "0" Loud Switch "Off" Volume "Max" Mode Switch "Mono"	AC VTVM	1V	Speaker A "L" or "R" 8 ohm load	Speaker A "G" 8 ohm load	Set output for 0 dB. Rotate balance control. Note 45 dB drop in output. Check attenuation both channels. Change inputs.	Min.
Harmonic* Distortion	Aux 20 Hz 1000 Hz 20,000 Hz	Selector "Aux" Mode Switch "Mono" Balance "Equal output" Volume "Max"	AC VTVM Harmonic Distortion Analyzer	30V	Speaker A "L" or "R" 8 ohm load	Speaker A "G" 8 ohm load	Set output to: 14.1V A417 18.3V A437 Measure Distortion.	0.3% THD

\*Note: Power line voltage 120V AC < 2.0% line THD.



AUDIO TEST PROCEDURE A417 AND A437  
Serial No. SUFFIX PC OR PD

TEST	INPUT	CONTROL SETTINGS	TEST EQUIPMENT	SCALE SETTINGS	MEASURE AT		READINGS	TOL.
					POSITIVE PROBE	NEGATIVE PROBE		
Damping Factor	Aux 1000 Hz	Selector "Aux" Mode Switch "Mono" Balance "Center" Volume "Max"	AC VTVM	10V	Speaker A "L" or "R" 8 ohm load	Speaker A "G" 8 ohm load	Set output to 8 volts, remove load & note increase in level of both channels. Max. 0.5 dB	
Main Amp input A437	Remove jumper link, plug to M. A. in		AC VTVM	1V	Speaker A "L" or "R"	Speaker A "G"	Note reduction in level 12 dB Replace link	+1dB
Head Phone Output	Aux 1000 Hz	Aux Mono	AC VTVM	1V			Note level 20 dB below speaker level	+2dB

AUDIO TEST PROCEDURE A437 AND A457  
Serial No. SUFFIX KC OR KD

TEST	INPUT	CONTROL SETTINGS	TEST EQUIPMENT	SCALE SETTINGS	MEASURE AT		READINGS	TOL.
					POSITIVE PROBE	NEGATIVE PROBE		
DC Resistance Check	None Unit "Off"		VOM	Ohms X 1000	+ Filter cap	P810 } P805 } A437 P606 } P604 } A457	12K Measure	+1K
DC Resistance	Same		VOM	Ohms X 10	P810 } P805 } A437 P606 } P604 } A457	- Filter cap	40 ohms	+1K
B+ Supply	None Unit "On"	Volume "Min" Selector "Aux"	VOM	Volts 60 DC	+ Filter cap	Chassis	38V DC A437 44V DC A457	+5%
B- Supply	Same	Same	VOM	Volts 60 DC	Chassis	- Filter cap	-38V DC A437 -44V DC A457	+5%
Regulated B+ Voltage	Same	Same	VOM	Volts 60 DC	P901 A437 P611 A457 Supply Board	Chassis	+13V DC	+10%
Output Offset Voltage	Same	Same	VOM	12mA DC	Speaker A "L" or "R"	Speaker A "C"	+1.25 mA	Max.
			DC Milli-voltmeter	100mV	Speaker A "L" or "R"	Speaker A "C"	+25 mV	Max.
Bias Check	Same	Same Adjust R809 or R830-A437 Change value of R611 or R640, or adj. bias pot if provided, in A457.	VOM	12mA DC	Emitter of: Q807 } Q817 } A437 Q609 } Q619 } A457	Collector of: Q810 } Q820 } A437 Q610 } Q620 } A457	Adjust pad for 0.2mA DC nominal.	+100% -0
			DMM	mV	Same as above	Same as above	5mV	+100% -0

AUDIO TEST PROCEDURE A437 AND A457  
Serial No. SUFFIX KC OR KD

TEST	INPUT	CONTROL SETTINGS	TEST EQUIPMENT	SCALE SETTINGS	MEASURE AT		READINGS	TOL.
					POSITIVE PROBE	NEGATIVE PROBE		
Audio Level 8 ohm	Aux 1000 Hz	Selector "Aux" Mode Switch "Mono" Volume "Max"	AC VTVM Scope	30V 5V/DIV	Speaker A "L" or "R" 8 ohm load	Speaker A "G" 8 ohm load	Adjust input for: 18.3V A437 21.9V A457 at outputs. input level should be 0.15V. Output not clipped w/120V line.	w/input +2dB
Tape Inputs	Tape In 1000 Hz	Tape Monitor Switch "Monitor"	Same	30V	Speaker A "L" or "R" 8 ohm load	Speaker A "G" 8 ohm load	Output: 18.3V A437 21.9V A457 w/input of 0.15V	Input +2dB
Tape Monitor Output	Aux	Selector "Aux" Volume "Min"	AC VTVM	1V	Tape Out	Ground	Output of 0.15V w/input of 0.15V	
Mode Switch Switch L & R L R Stereo Rev. Ster.	Aux L 0.025V " " " " "	Volume "Max"	AC VTVM	1V	Speaker A "R"	Speaker A "G"	Output Level 0 dB 0 dB both chan. 0 dB both chan. No output 0 dB L chan. 0 dB R chan.	
Frequency Response Power Amp & Tone Control	Aux	Tone Control "0" Volume "Max" Balance "Center"	AC VTVM	1V	Speaker A "L" or "R" 8 ohm load	Speaker A "G" 8 ohm load	Adjust input for 0 dB (.775V) out (3dB down points should be below 10 Hz and above 30 kHz)	+1dB



AUDIO TEST PROCEDURE A437 AND A457  
Serial No. SUFFIX KC OR KD

TEST	INPUT	CONTROL SETTINGS	TEST EQUIPMENT	SCALE SETTINGS	MEASURE AT		READINGS	TOL.
					POSITIVE PROBE	NEGATIVE PROBE		
Tone Control Response	Aux 1000 Hz	Selector "Aux" Mode Switch "Mono" Tone Control "0"	AC VTVM	1V	Speaker A "L" or "R" 8 ohm load	Speaker A "G" 8 ohm load	Adjust output 0 dB (0.78V) Note: 100 Hz Bass boost 10dB Bass cut 10dB 10 kHz Treble boost 10dB Treble cut 10dB	+2dB
Loudness Compensation	Aux 1000 Hz 100 Hz 10 kHz ----- Increase input 20dB 20 dB	Selector "Aux" Tone Control "0" Volume "11 O'clock" Loud. Sw. "On"	AC VTVM	1V	Speaker A "L" or "R" 8 ohm load	Speaker A "G" 8 ohm load	Adjust output for 0dB. Freq. to 10 kHz; Note 3dB incre- ase. Freq. to 100 Hz; note 7dB increase.	
Crosstalk	Aux Left Channel 1000 Hz	Selector "Aux" Tone Control "0" Loud. Sw. "Off" Volume "Max" Mode Switch "Stereo"	AC VTVM	1V	Speaker A "L" 8 ohm load	Speaker A "G" 8 ohm load	Set output for 0dB, read right channel output 45 dB down.	Min.
Low & High Filter	1 kHz 100 Hz 10 kHz	Selector "Aux" Mode Switch "Mono"	AC VTVM Scope	1V	Speaker A "L" or "R"	Speaker A "G"	Max. 1dB Change @ 1 kHz Low Filter @ 100 Hz -8dB A437 -3dB A457 High Filter @ 10 kHz -3dB Both	+2dB



AUDIO TEST PROCEDURE A437 AND A457  
Serial No. SUFFIX KC OR KD

TEST	INPUT	CONTROL SETTINGS	TEST EQUIPMENT	SCALE SETTINGS	MEASURE AT		READINGS	TOL.
					POSITIVE PROBE	NEGATIVE PROBE		
Meters	Aux 1 kHz	Mono	AC VTVM	30V	Speaker A "L" or "R"	Speaker A "G"	W/output level at: 18.3V A437 21.9V A457 both channels, amplifier in normal operat- ing position, check & set meters for 100% reading. Check for app. $\frac{1}{2}$ scale meter indicat- ion w/0.36V-A437 output. 0.3V-A457	$\pm 2$ dB
Balance Control	Aux 1000 Hz Left Channel Right Channel	Selector "Aux" Tone Control "0" Loud Sw. "Off" Volume "Max" Mode Switch "Mono"	AC VTVM	1V	Speaker A "L" or "R" 8 ohm load	Speaker A "G" 8 ohm load	Set output for 0dB. Rotate balance control. Note 45dB drop in output. Check attenuation both channels. change inputs.	Min.
Harmonic* Distortion	Aux 20 Hz 1000 Hz 20,000 Hz	Selector "Aux" Mode Switch "Mono" Balance "Equal" Volume "Max"	AC VTVM Harmonic Distortion Analyzer	30V	Speaker A "L" or "R" 8 ohm load	Speaker A "G" 8 ohm load	Set output to: 18.3V A437 21.9V A457 Measure distort- ion.	0.3% THD 0.2% THD

\*Note: Power line Voltage 120V AC < .2.0% line THD.

AUDIO TEST PROCEDURE A437 AND A457  
Serial No. SUFFIX KC OR KD

TEST	INPUT	CONTROL SETTINGS	TEST EQUIPMENT	SCALE SETTINGS	MEASURE AT		READINGS	TOL.
					POSITIVE PROBE	NEGATIVE PROBE		
Audio Level 8 ohm	Aux 1000 Hz	Selector "Aux" Mode Switch "Mono" Volume "Max"	AC VTVM Scope	30V 5V/DIV	Speaker A "L" or "R" 8 ohm load	Speaker A "G" 8 ohm load	Adjust input for: 18.3V    A437 21.9V    A457 at outputs. input level should be 0.15V. Output not clipped w/120V line.	w/input <u>+2dB</u>
					Repeat for Speaker --B--			
Tape Inputs	Tape In 1000 Hz	Tape Monitor Switch "Monitor"	Same	30V	Speaker A "L" or "R" 8 ohm load	Speaker A "G" 8 ohm load	Output: 18.3V    A437 21.9V    A457 w/input of 0.15V	Input <u>+2dB</u>
Tape Monitor Output	Aux	Selector "Aux" Volume "Min"	AC VTVM	1V	Tape Out	Ground	Output of 0.15V w/input of 0.15V	
Mode Switch Switch L & R L R Stereo Rev. Ster.	Aux L 0.025V " " " " "	Volume "Max"	AC VTVM	1V	Speaker A "R"	Speaker A "G"	Output Level 0 dB 0 dB both chan. 0 dB both chan. No output 0 dB L chan. 0 dB R chan.	
Frequency Response Power Amp & Tone Control	Aux	Tone Control "0" Volume "Max" Balance "Center"	AC VTVM	1V	Speaker A "L" or "R" 8 ohm load	Speaker A "G" 8 ohm load	Adjust input for 0 dB (.775V) out (3dB down points should be below 10 Hz and above 30 kHz)	<u>+1dB</u>

## CIRCUIT DESCRIPTION OF THE POWER AMPLIFIER

Refer to schematic diagram

Q506 and Q510 are the power output devices and Q505 and Q509 are the drivers. These transistors provide current gain to drive the loudspeaker load. The differential input transistors, Q501 and Q502, along with the voltage amplifier, Q503, provide the necessary voltage gain and feedback to minimize distortion. Resistors, R505 and R506, control the amount of negative feedback and the gain of the driver.

Q504, with resistors R507, R508 and R509, set the bias in the output stage to maintain class AB operation and prevent crossover distortion. Q507 and Q508 are the protection transistors. The protection transistors will conduct when the AC voltage drop across R516 and R517 exceeds a preset level. This level is determined by R512, R513, R515 and R518. When the protection transistors conduct, they provide a short circuit signal path, that in turn, limits the signal drive on the base of Q505 and Q509.

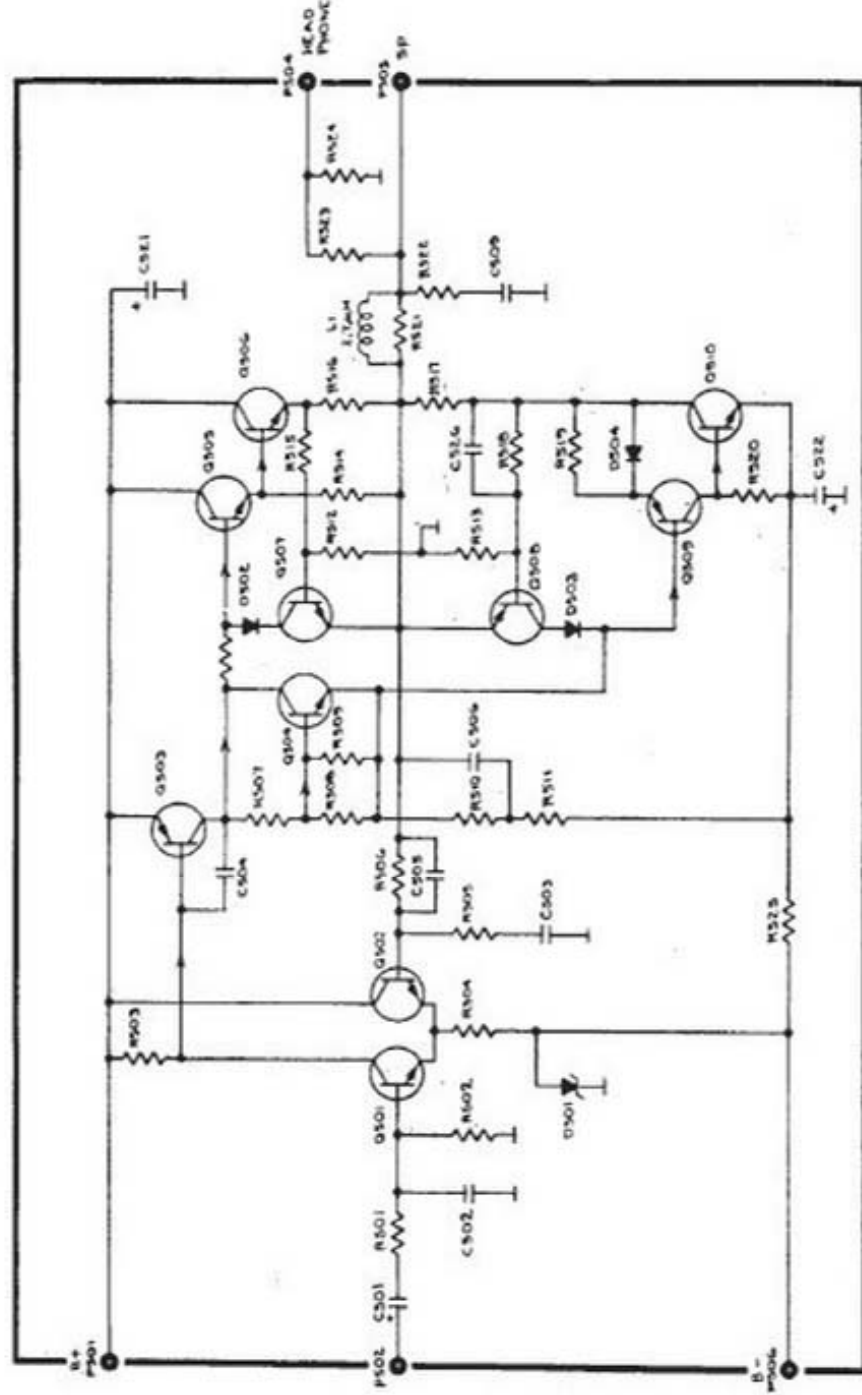

SEE Page 14-1



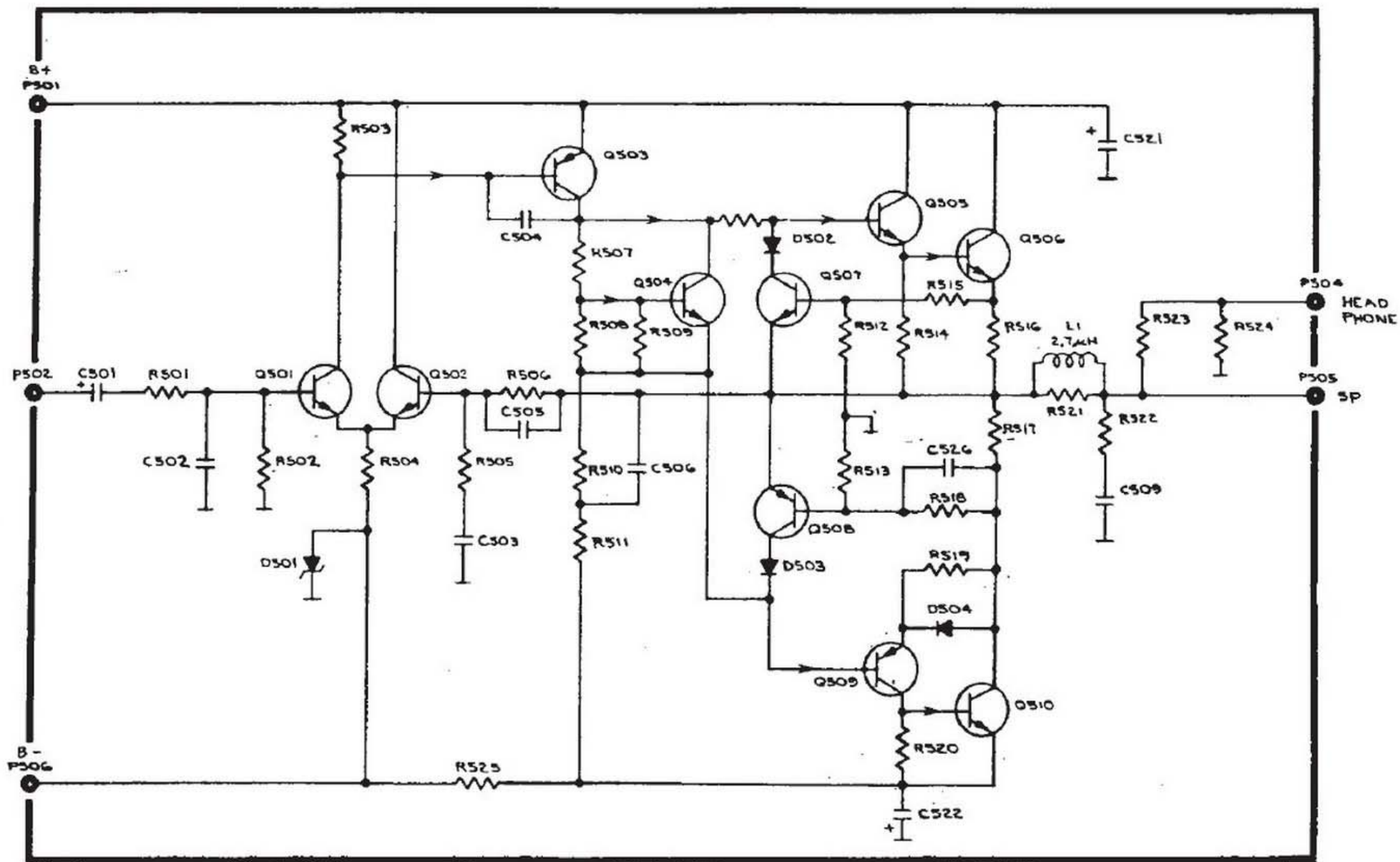



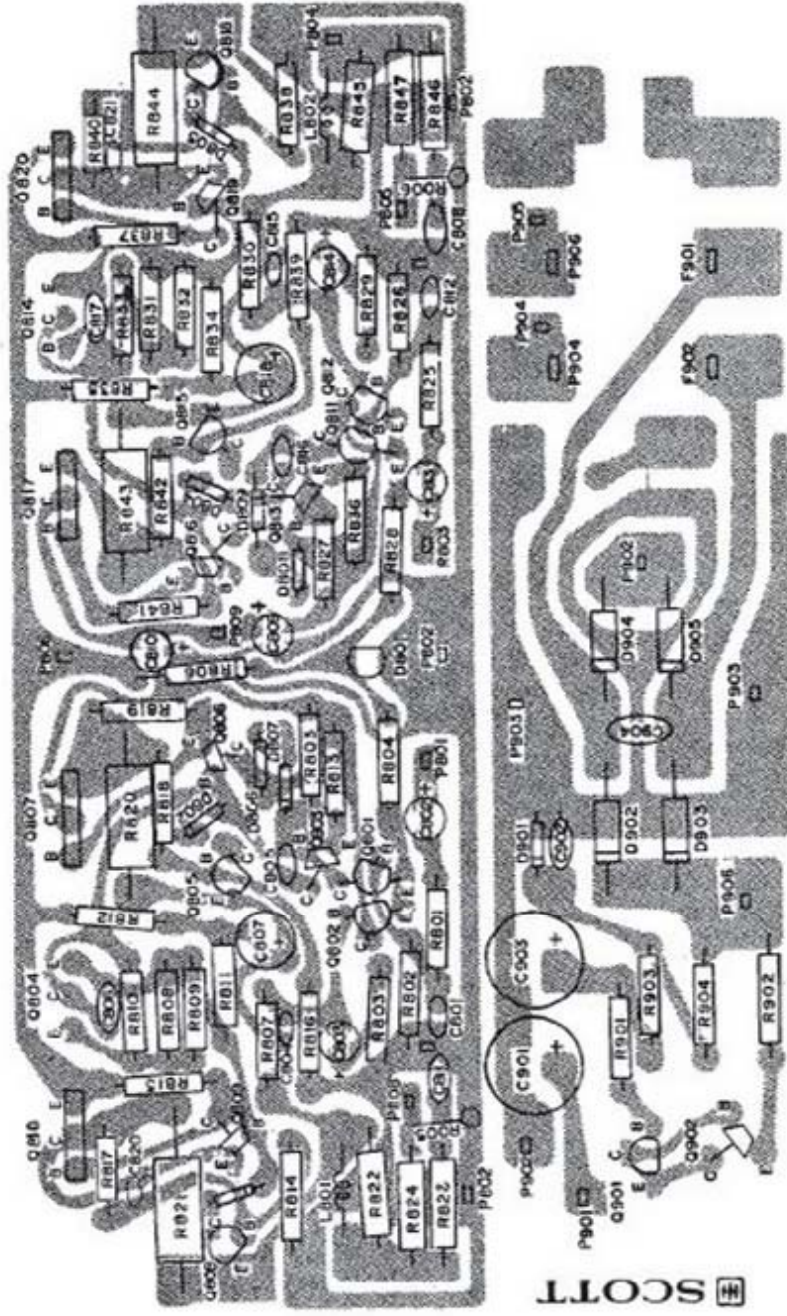

A417 DRIVER/REGULATOR  
 Assy No. 100-1335-031

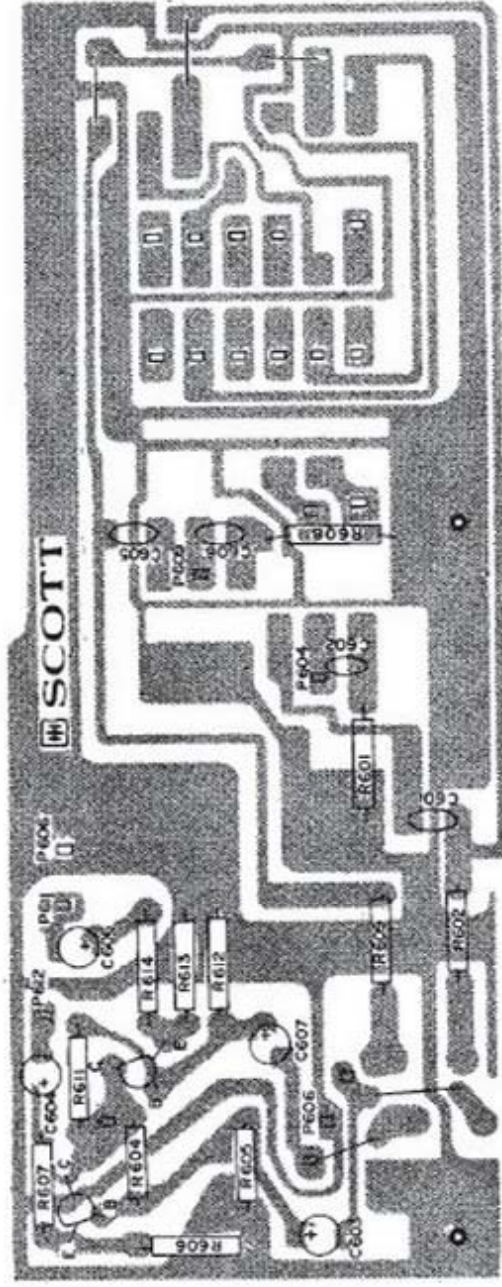

A417 TONE BOARD "B"  
 Assy No. 100-1334-041



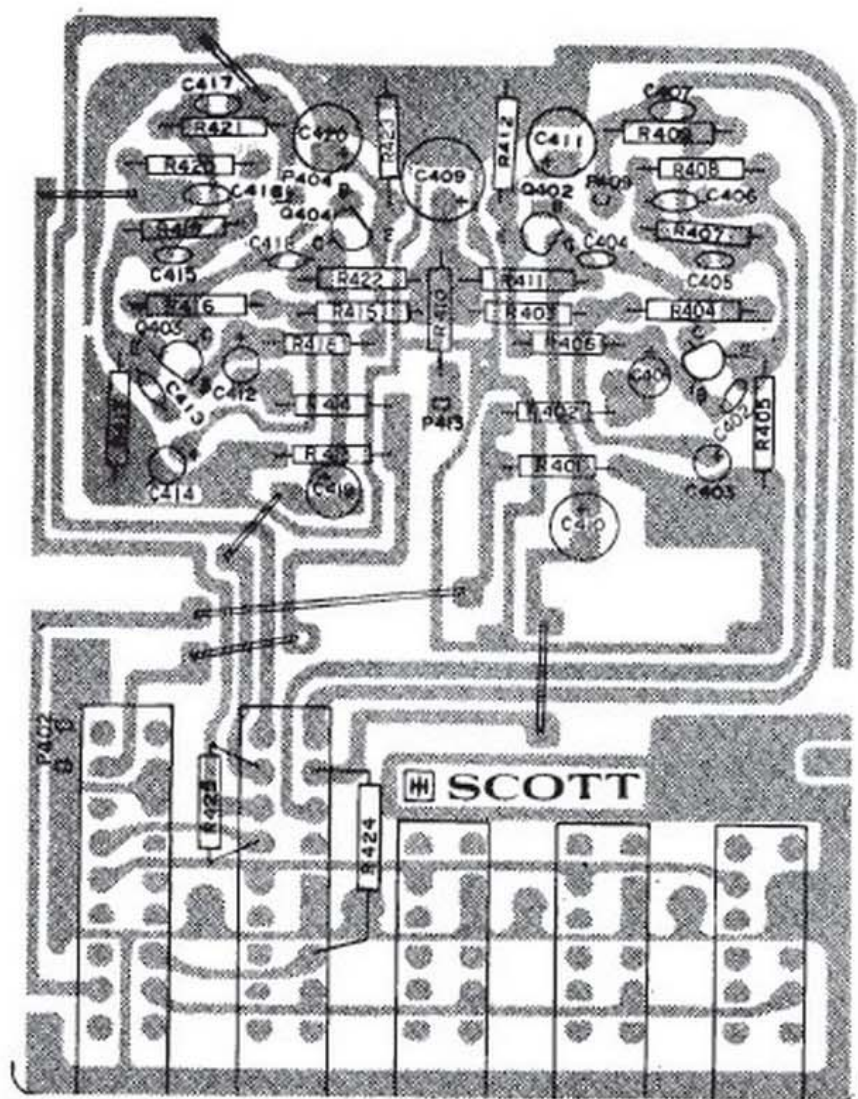

A417 PREAMP SWITCH BOARD  
 Assy No. 100-1333-047

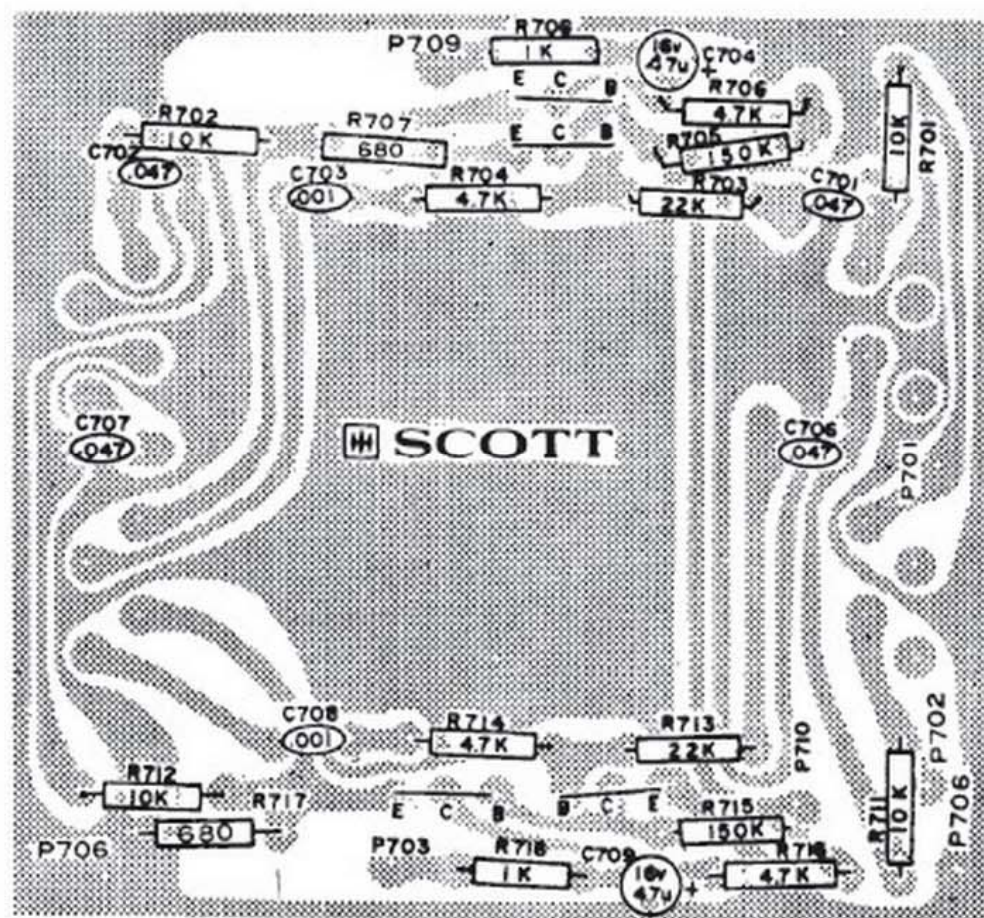

A417 TONE BOARD "A"  
 Assy No. 100-1334-033



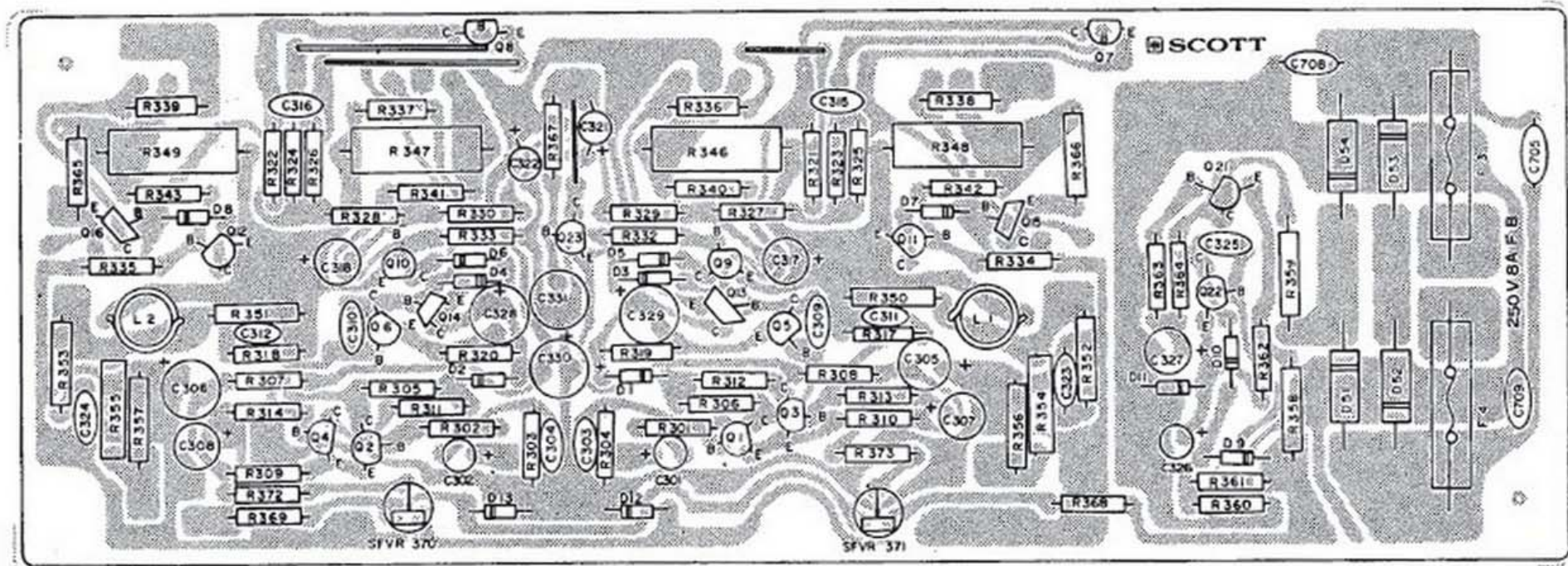

A437 DRIVER/REGULATOR BOARD  
 Assy No. 100-1335-034



A437 SPEAKER SWITCH BOARD  
 Assy No. 100-1352-043

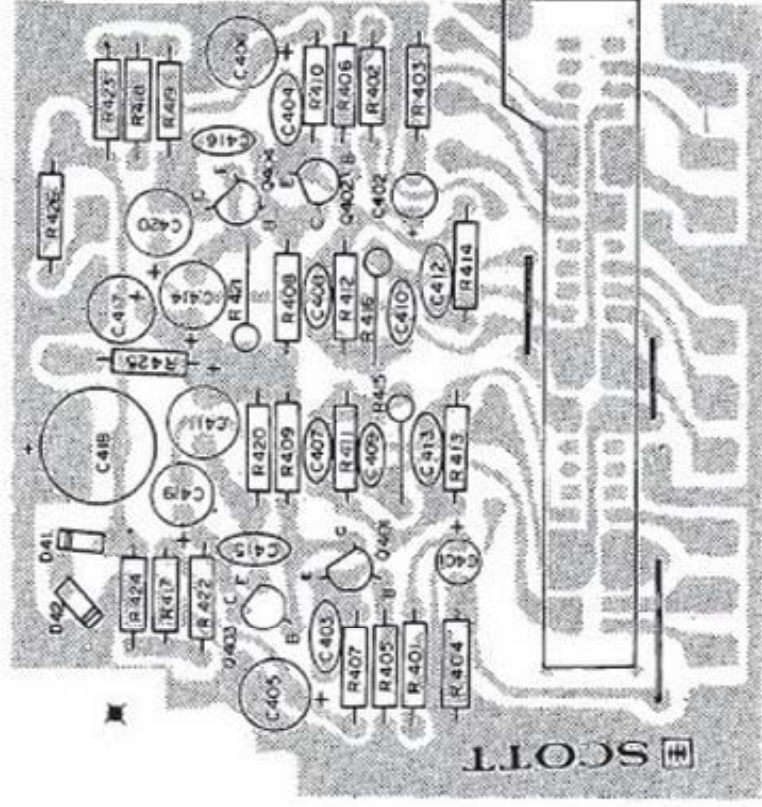

A437 PREAMP/SWITCH BOARD  
 Assy No. 100-1333-048

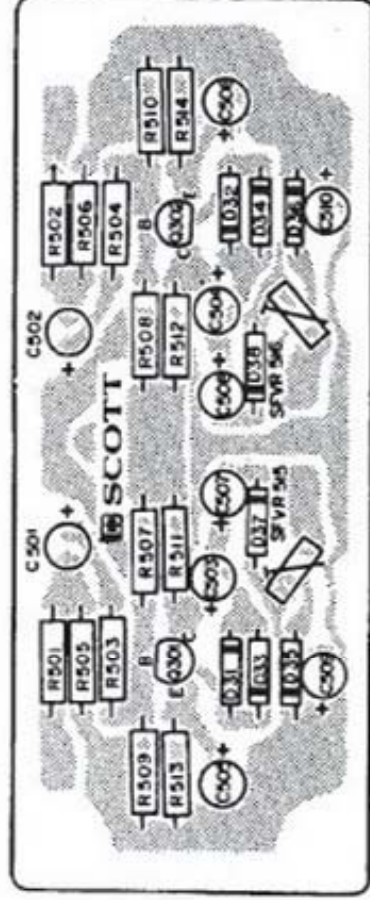

A437 METER DRIVE  
 Assy No. 100-1335-032



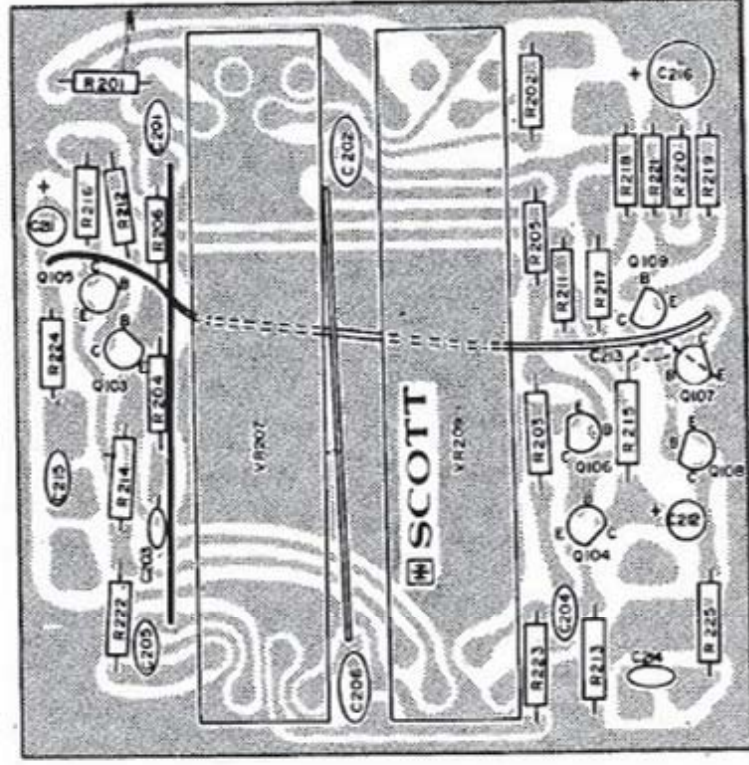

A437 TONE BOARD "A"  
 Assy No. 100-1334-045

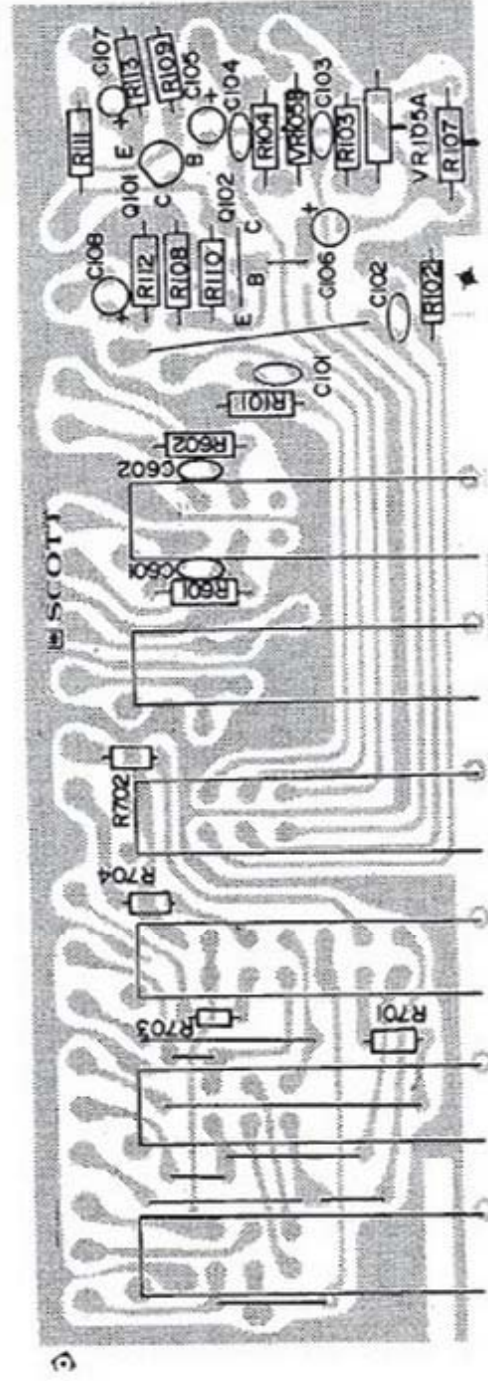

A437 TONE BOARD "B"  
 Assy No. 100-1334-046

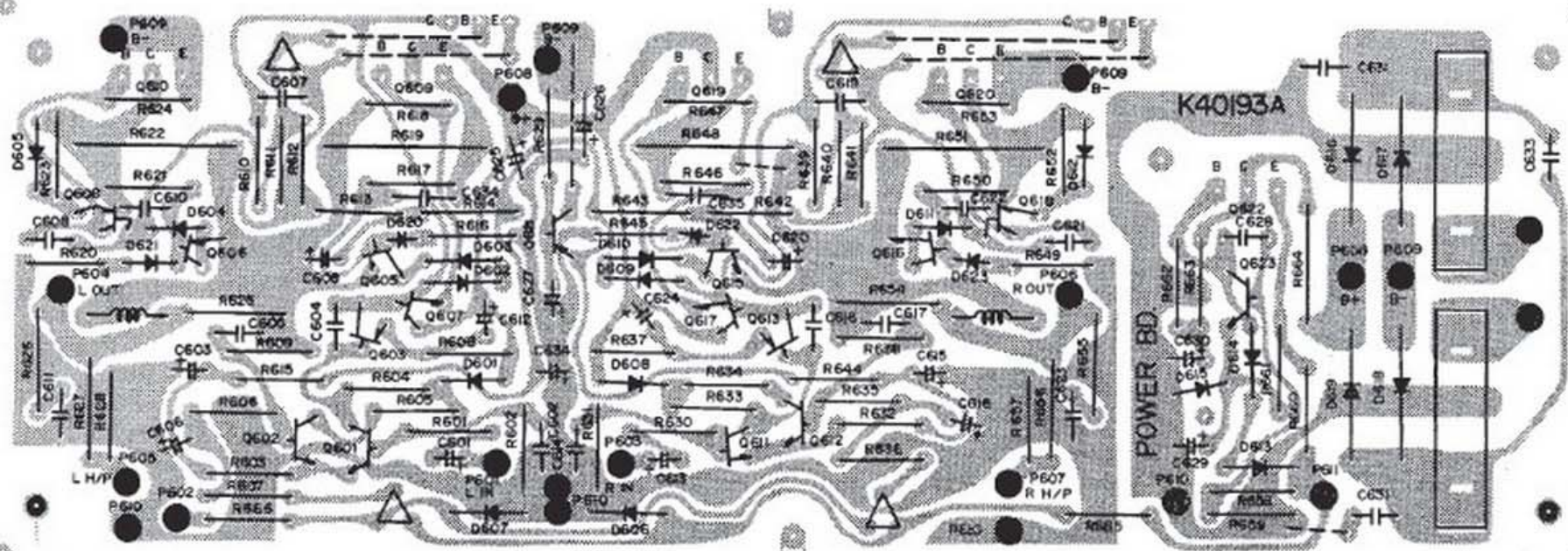

A457 DRIVER/REGULATOR BOARD  
 Assy No. 100-1335-033

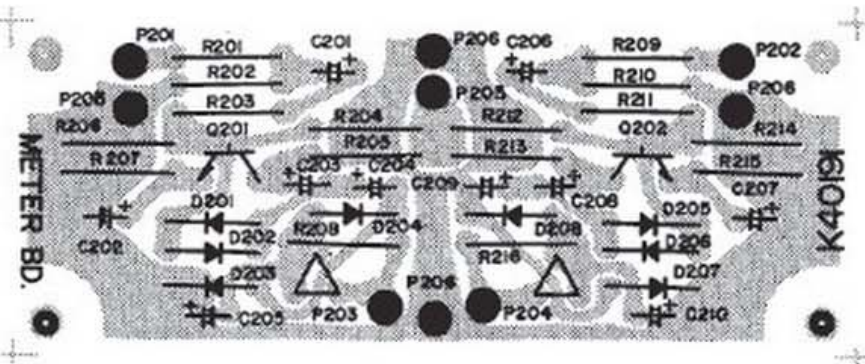

A457 METER DRIVE BOARD  
 Assy No. 100-1335-035



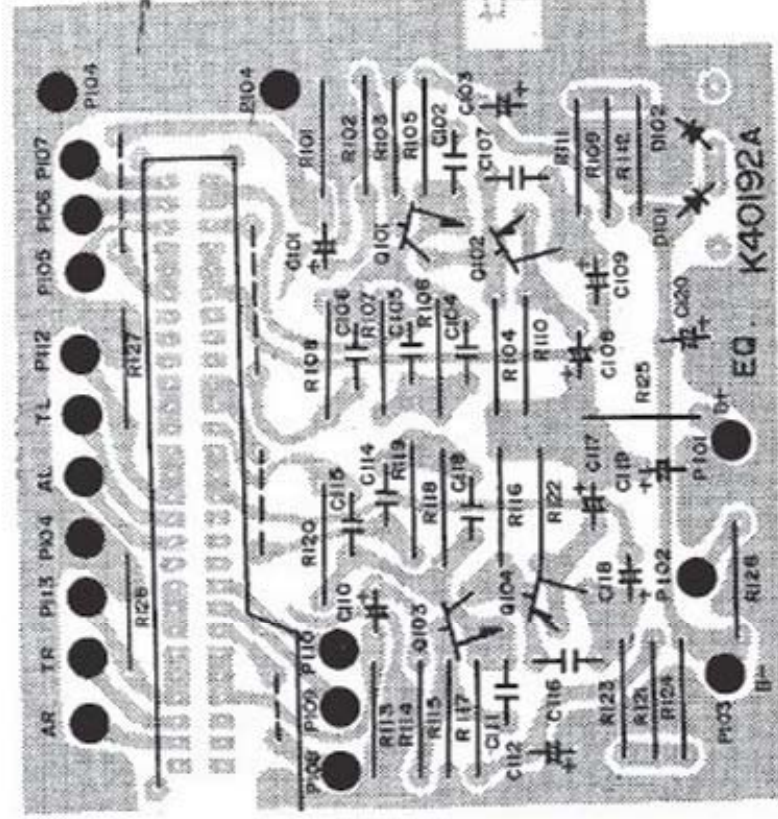

A457 PREAMP/SWITCH  
 Assy No. 100-1333-049

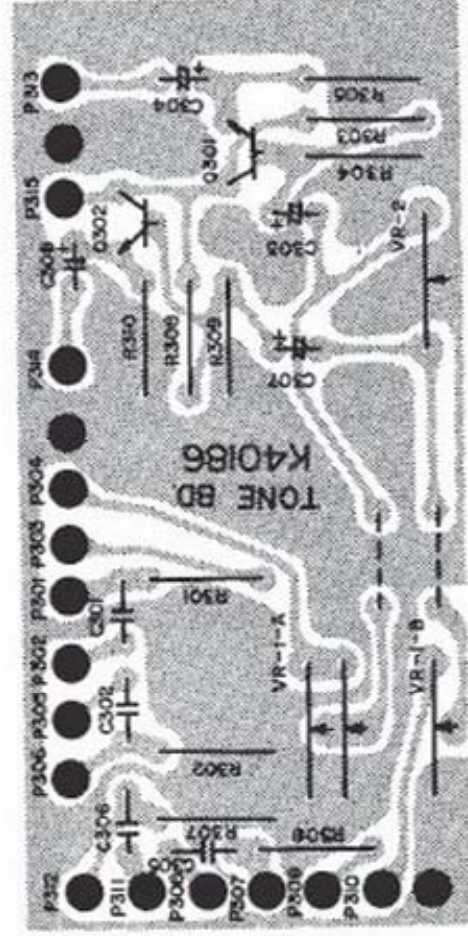

A 457 TONE BOARD "A"  
 Assy No. 100-1334-042

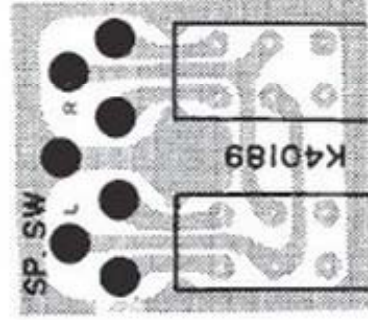

A457 SPEAKER SWITCH BOARD  
 Assy No. 100-1352-045



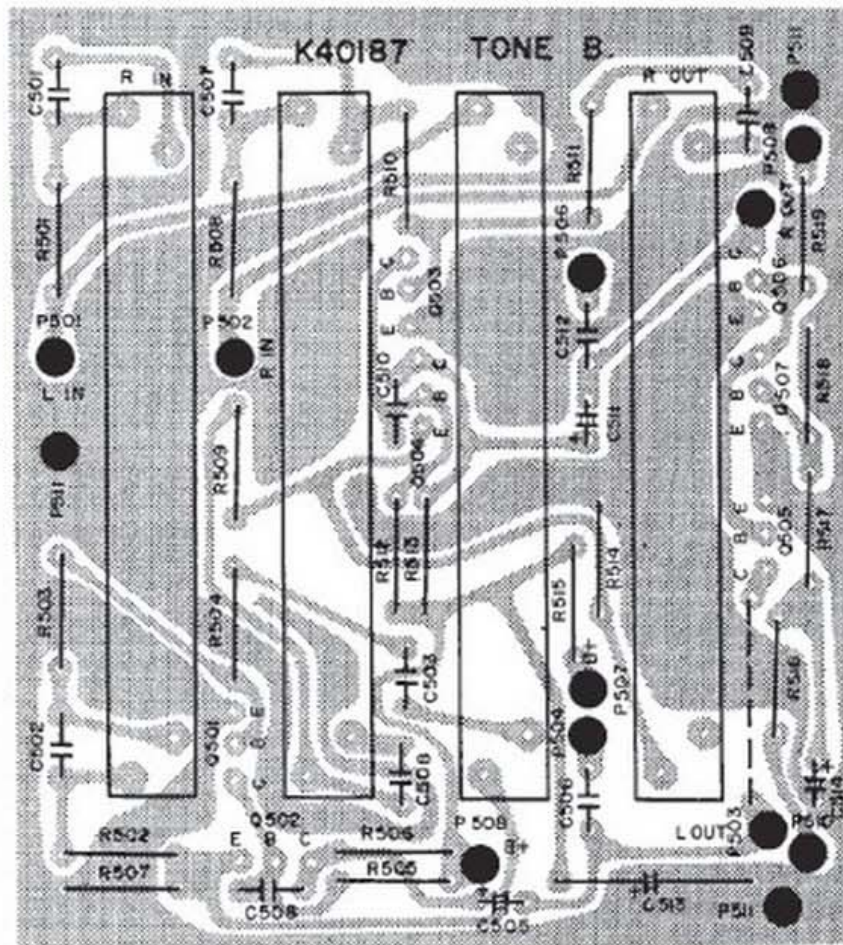

A457 TONE BOARD "B"  
 Assy No. 100-1334-043

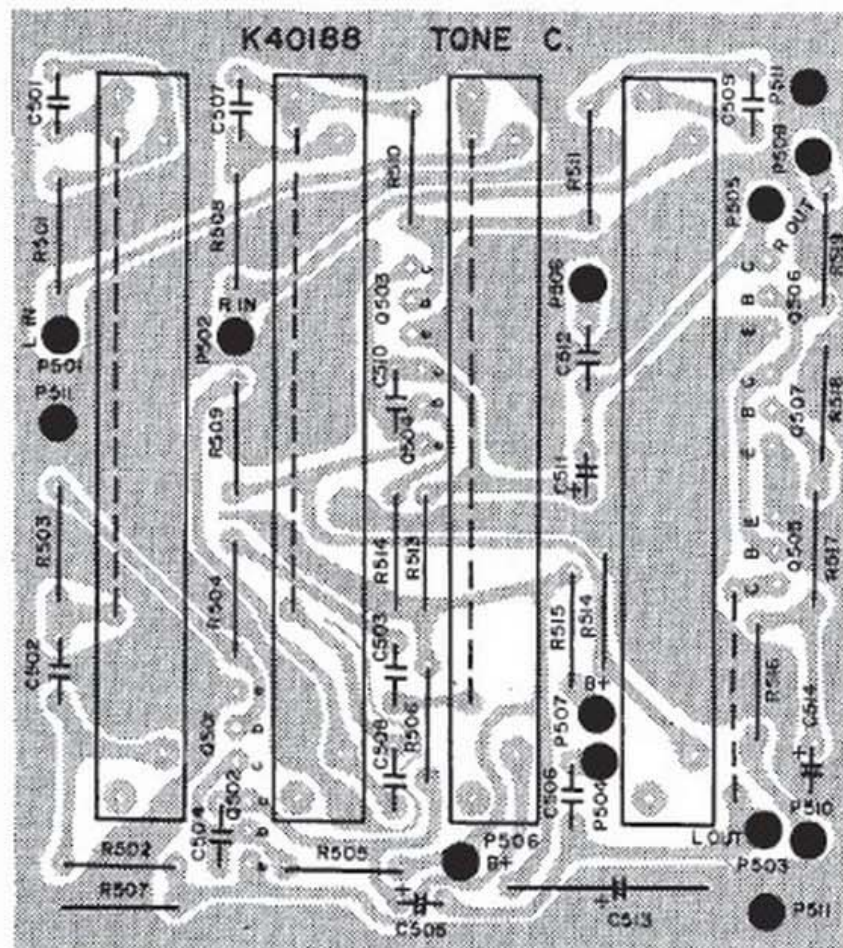

A457 TONE BOARD "C"  
 Assy No. 100-1334-044

NOTE: PRODUCT MAY BE MANUFACTURED USING  
 EITHER TONE BOARD "B" OR "C"



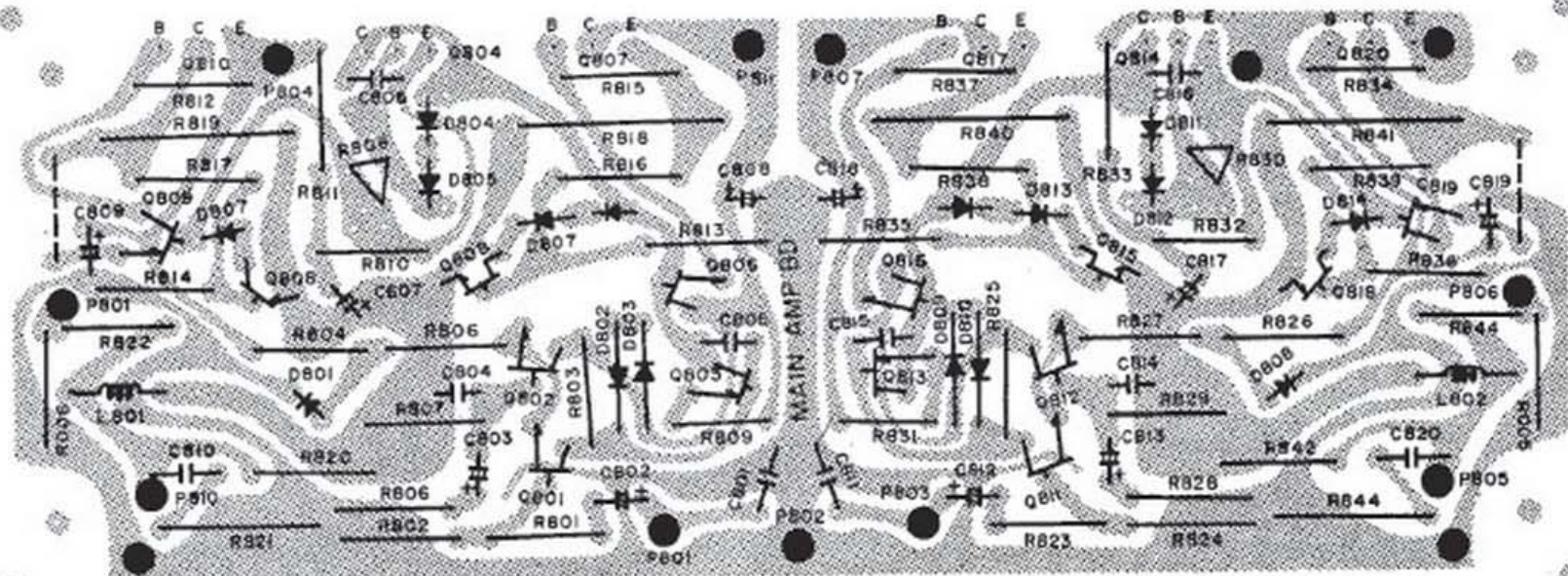

A437 DRIVER BOARD  
 Assy No. 100-1335-036

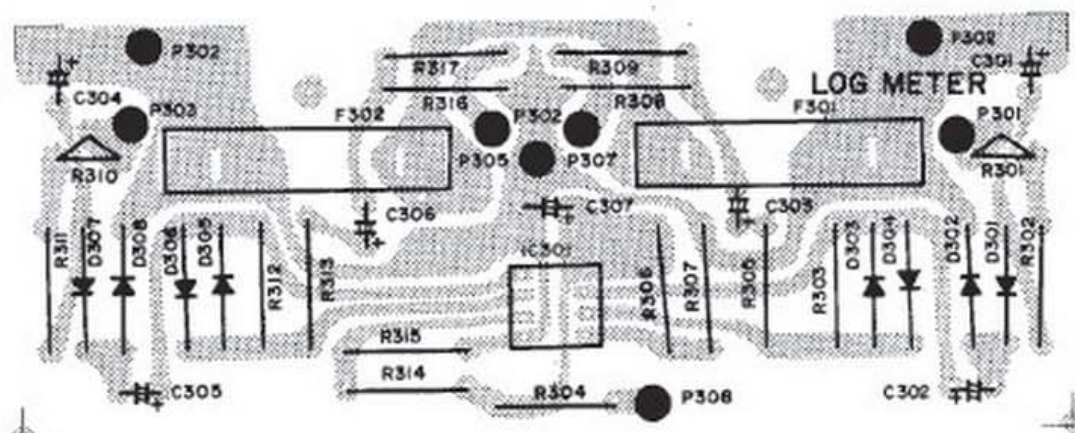

A437 METER DRIVE BOARD  
 Assy No. 100-1335-037







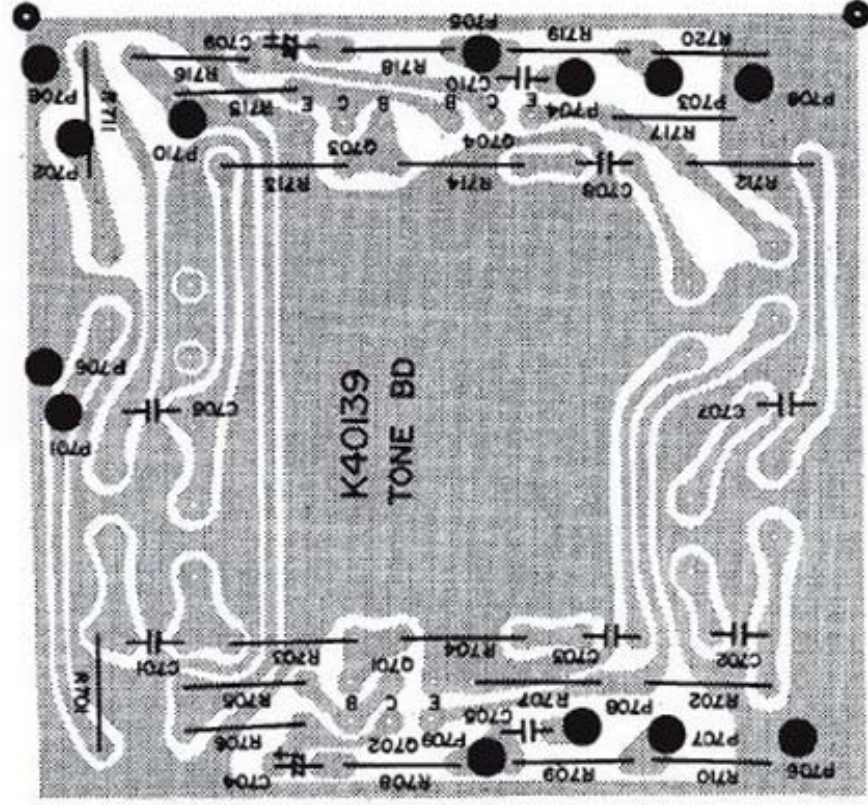

A437 TONE BOARD "B"  
Assy No. 100-1334-048

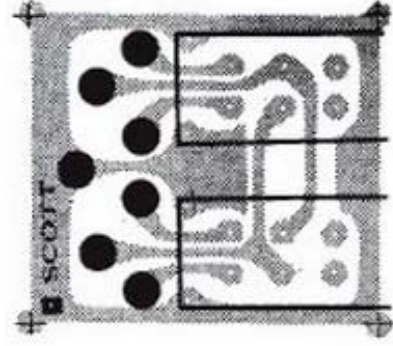

A437 SWITCH BOARD  
Assy No. 100-1352-028

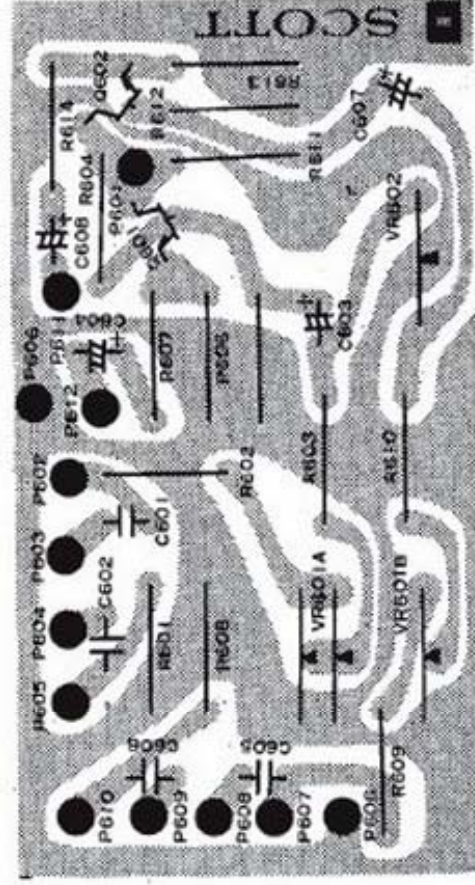

A437 TONE BOARD "A"  
Assy No. 100-1334-047



## CIRCUIT DIAGRAM NOTES

The following resistors are safety critical components, and must be replaced ONLY with parts approved by H. H. Scott, Inc.:

Model No. A417

R815; R817; R818; R819;  
R837; R840; R841; R842.

Model No. A437 With Serial No. Suffix PC or PD.

R336; R337; R338; R339;  
R340; R341; R342; R343.

Model No. A437 With Serial No. Suffix KC or KD.

R812; R815; R816; R817;  
R834; R837; R838; R839.

Model No. A457

R617; R618; R621; R624;  
R646; R647; R650; R653.

NOTE: Shunt resistor, 470 ohm,  $\frac{1}{2}$  watt, may be added across the output emitter resistor\* to adjust tolerance and provide symmetrical operation of protection circuit in the following units:

Model No. A437 With Serial No. Suffix KC or KD.  
\*R819, 818, 840 and 841.

Model No. A457 With Serial No. Suffix KC or KD.  
\*R622, 619, 648 and 651.

SEMICONDUCTOR OUTLINES

MPS 9630  
MPS 9632  
MPS 9633  
MPS 9484  
MPS 9680  
MPS 9700  
MPS 9750



MPS A06  
MPS L51  
MPS A55  
LBC 547  
2N 5400  
2N 5401



2SC 733  
2SC 374  
2SC 372  
2SA 495  
2SA 494  
2SA 842  
2SC 1000

MPS U56  
MPS U55

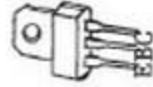

2SA 661  
2SC 1166



2SD 525  
2SD 234  
TIP 31B

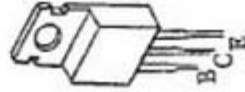

2SD 371  
2SD 428

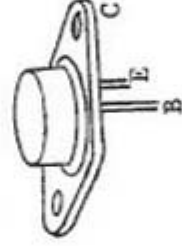

# SCHEMATIC DIAGRAM

## Model N° A417

4 BIAS CURRENT OF OUTPUT TRANSISTORS IS MEASURED AS FOLLOWS: SET VOM TO 17mA RANGE. MEASURE CURRENT ACROSS BOTH 0.27 OHM RESISTORS ON THE DRIVER AMPLIFIER BOARD. READ DIAL ON TRIPLET 850A ON 15mA SCALE. USE SAME PROCEDURE FOR EACH CHANNEL. ALLOW 5 MINUTE WARM-UP BEFORE ADJUSTING BIAS. SEE ALSO LISTING PROCEDURE.

NOTES:  
 1 RESISTANCE IN OHMS (%), (1/4W), (1/2W), CAPACITANCE IN MICROFARADS, UNLESS OTHERWISE SPECIFIED.  
 2 UNLESS OTHERWISE SPECIFIED, ALL DC VOLTAGES ±15% UNLESS WITH RESPECT TO CHASSIS GROUND, USING VOM, POWER LINE 100VAC.  
 3 DC OUTPUT VOLTAGE WITH NO SIGNAL APPLIED, READ 0 VOLTS ±25% AT SPEAKER & OUTPUT TERMINAL. 125.7V IS 1.25 MA ON TRIPLET 850A 15mA SCALE.

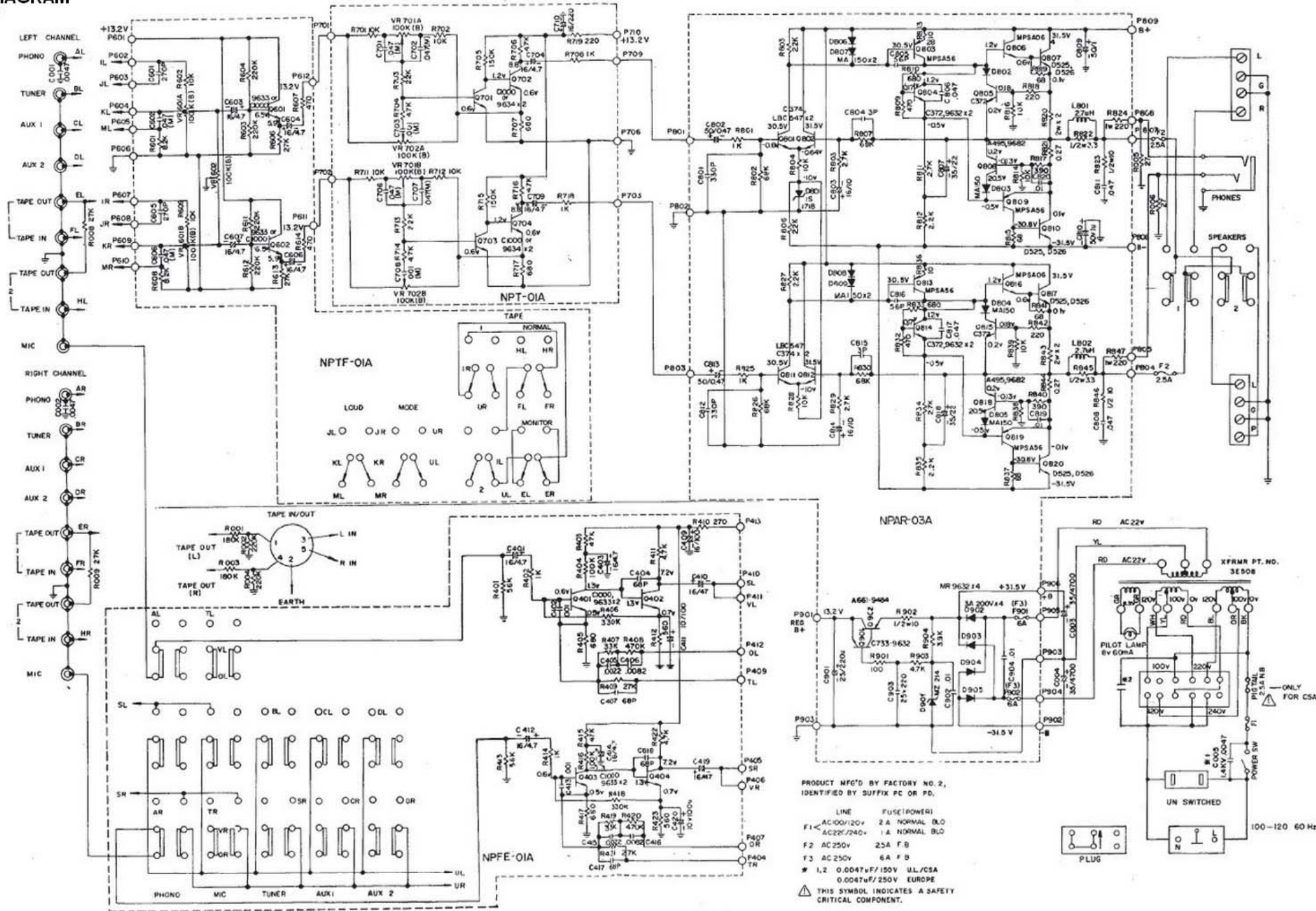

PRODUCT MFG'D BY FACTORY NO. 2, IDENTIFIED BY SUFFIX PC OR PD.

LINE	FUSE (POWER)
F1	AC100/120V 2 A NORMAL BLO
F2	AC220/240V 1 A NORMAL BLO
F3	AC 250V 25A F.B
F4	AC 250V 6A F.B

\* 1.2 0.0047uF/150V UL/CSA  
 0.0047uF/250V EUROPE

THIS SYMBOL INDICATES A SAFETY CRITICAL COMPONENT.



# SCHEMATIC DIAGRAM Model N° A417

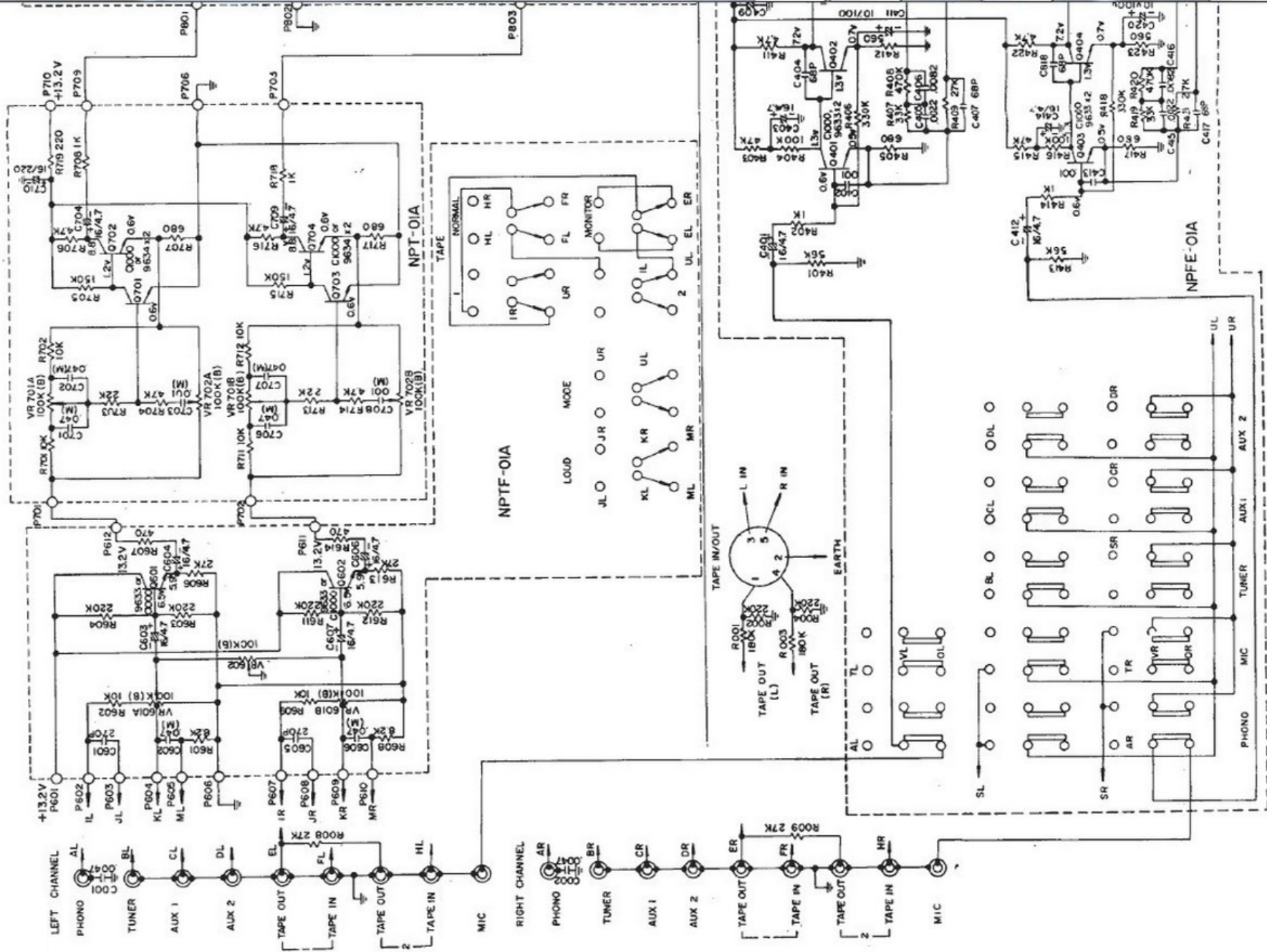

4 BIAS CURRENT OF OUTPUT TRANSISTORS IS MEASURED AS FOLLOWS SET VOM TO 12MA RANGE  
MEASURE CURRENT ACROSS BOTH 27 OHM RESISTORS ON THE DRIVER AMPLIFIER BOARD  
READ 0.2MA ON TRIPLET 500A OR 12MA SCALE USE SAME PROCEDURE FOR OTHER CHANNEL.  
ALLOW 5 MINUTE WARM-UP BEFORE ADJUSTING BIAS (SEE ALSO TEST PROCEDURE)

NOTES  
1 RESISTANCE IN OHMS ±10%, 1/4W. CAPACITANCE IN MICROFARADS, UNLESS OTHERWISE SPECIFIED.  
2 UNLESS OTHERWISE SPECIFIED, ALL DC VOLTAGES ±1% MEASURED WITH RESPECT TO CHASSIS  
GROUND, USING VTVM, POWER LINE 120VAC  
3 DC OFFSET VOLTAGE - WITH NO SIGNAL APPLIED, READ 0 VOLTS ±25MV AT SPEAKER A OUTPUT  
TERMINAL (25 MV IS 125 MA ON TRIPLET 500A 12MA SCALE)









# SCHEMATIC DIAGRAM

## Model N° A457

### NOTES:

1. RESISTANCE IN OHMS  $\pm 10\%$ ,  $1/4W$ ; CAPACITANCE IN MICROFARADS, UNLESS OTHERWISE SPECIFIED.
2. UNLESS OTHERWISE SPECIFIED, ALL DC VOLTAGES  $\pm 15\%$  MEASURED WITH RESPECT TO CHASSIS GROUND, USING VTVM, POWER LINE 120VAC

3. DC OFFSET VOLTAGE - WITH NO SIGNAL APPLIED, READ 0 VOLTS  $\pm 25mV$  AT SPEAKER A OUTPUT TERMINAL (25 mV IS 1.25 mA ON TRIPLET 630A 12mA SCALE).

4. BIAS CURRENT OF OUTPUT TRANSISTORS IS MEASURED AS FOLLOWS: SET VOM TO 12mA RANGE. MEASURE CURRENT ACROSS BOTH 0.27 OHM RESISTORS ON THE DRIVER AMPLIFIER BOARD. READ 0.2mA ON TRIPLET 630A ON 12mA SCALE. USE SAME PROCEDURE FOR OTHER CHANNEL. ALLOW 5 MINUTE WARM-UP BEFORE ADJUSTING BIAS. (SEE ALSO TEST PROCEDURE).

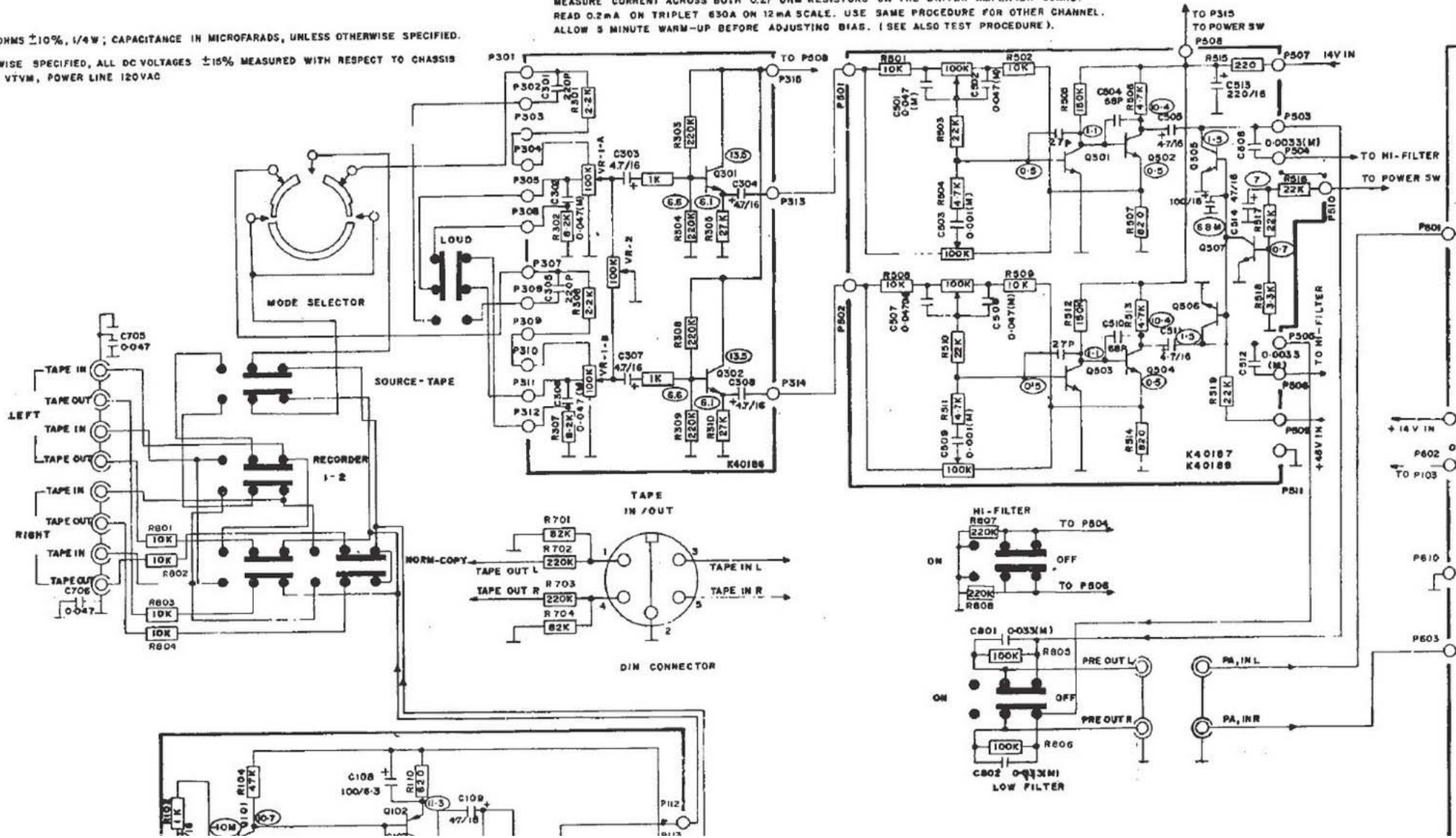

8804

DIN CONNECTOR

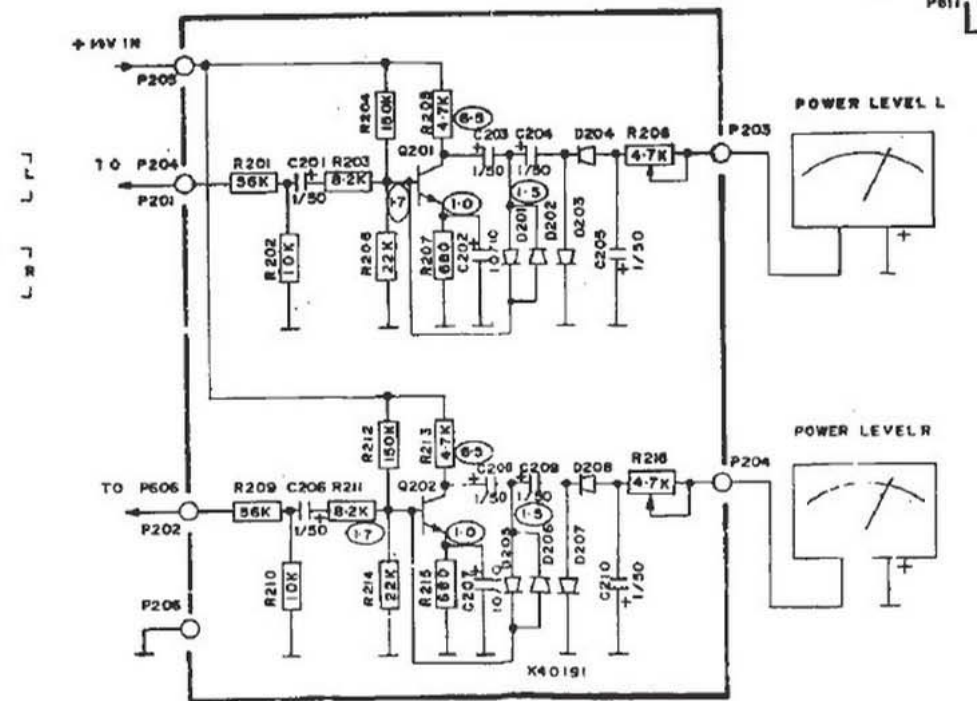
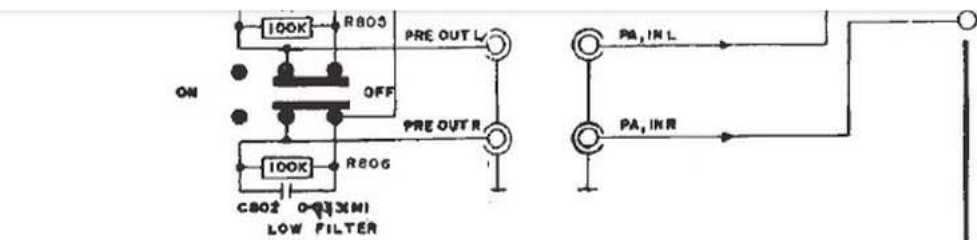
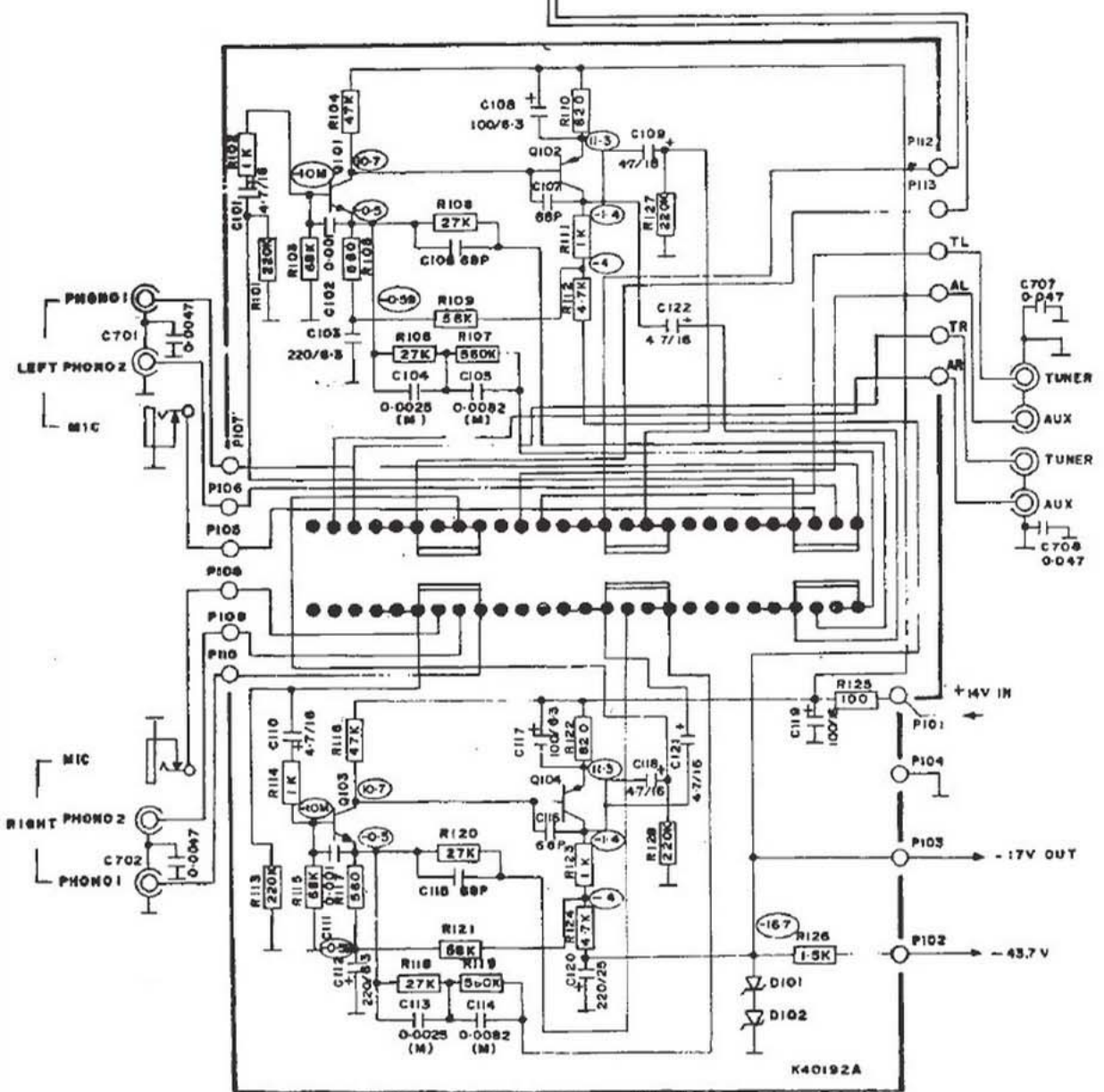

- C101, Q103 Q301, Q302, Q501 Q502 Q503 Q504 ----- 2SC 732BL (A) OR MPS 9633L/D (B)
- Q102, Q104 ----- 2SA 494 GR (A) OR 2SA 842 GR/BL (A)
- Q505, Q506, Q507, Q823, Q201, Q202 ----- CS 8013HG (B) OR MPS 8632 I (B)
- Q801, Q802, Q811, Q812 ----- 2SC 1000 BL (A)
- Q621 ----- CS 1821 (B) OR MPS A55 (B) 2SA 661 O (D)
- Q605, Q615 ----- 2SC 372 (A) OR MPS 9630 U (B)
- Q606, Q616 ----- 2SA 485 (A) OR MPS 9680 U (B)
- Q804, Q814 ----- MPS 9630 K (B)
- Q822 ----- 2SD, 234 (C) OR TIP 31B (C)

	F1	F2	C703	C704
U.S.A	4A/125V.STD	—	0.0047/150V.AC	0.0047/150 VAC
CANADA	4A/125VMB	5A/125VMB	0.0047/125V AC	0.0047/150 VAC
EUROPE	2A/250V.STD	—	0.0047/250V.AC	0.0047/250VAC

5% 3W 5W8 COPPER WIRE



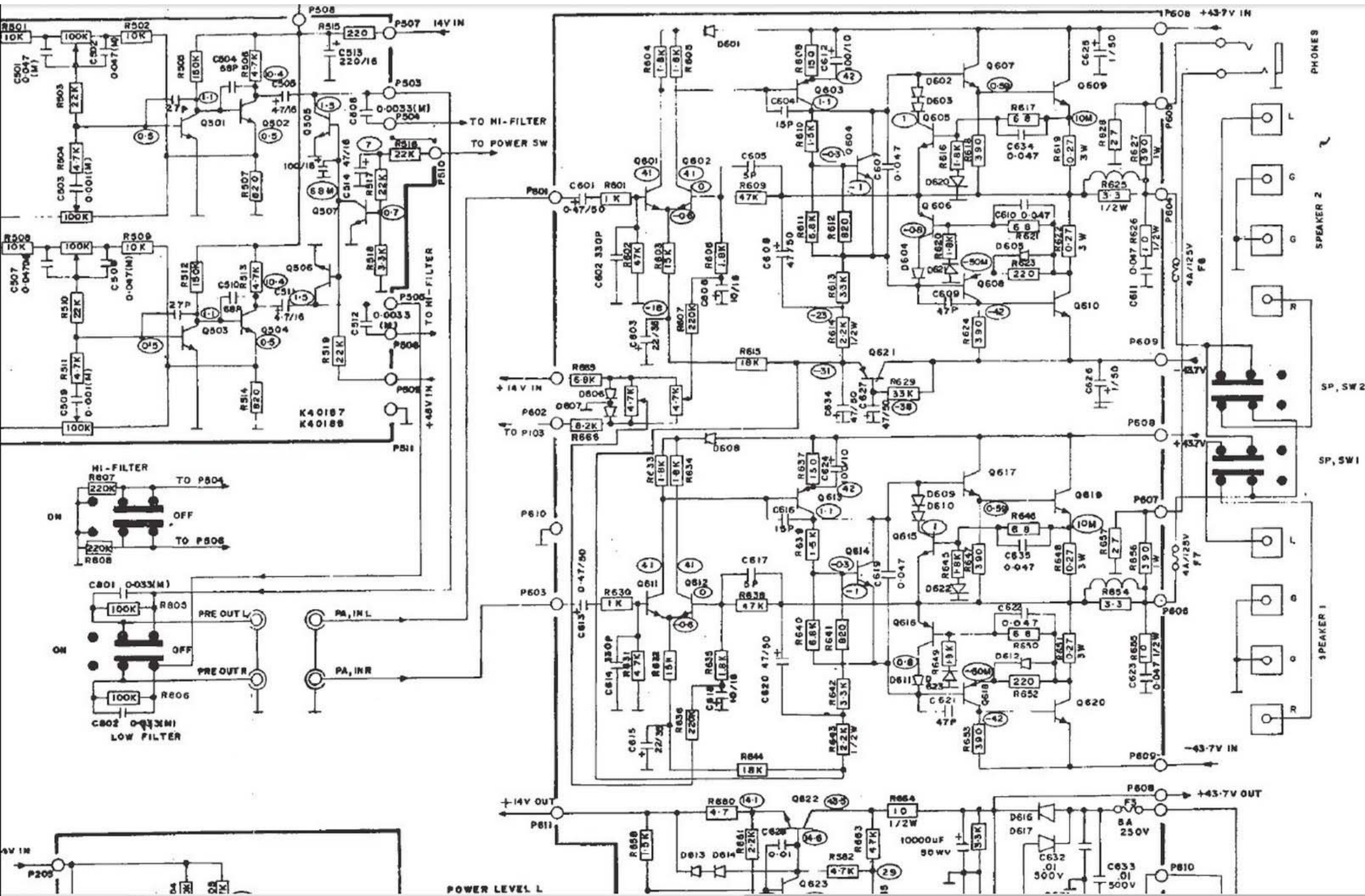

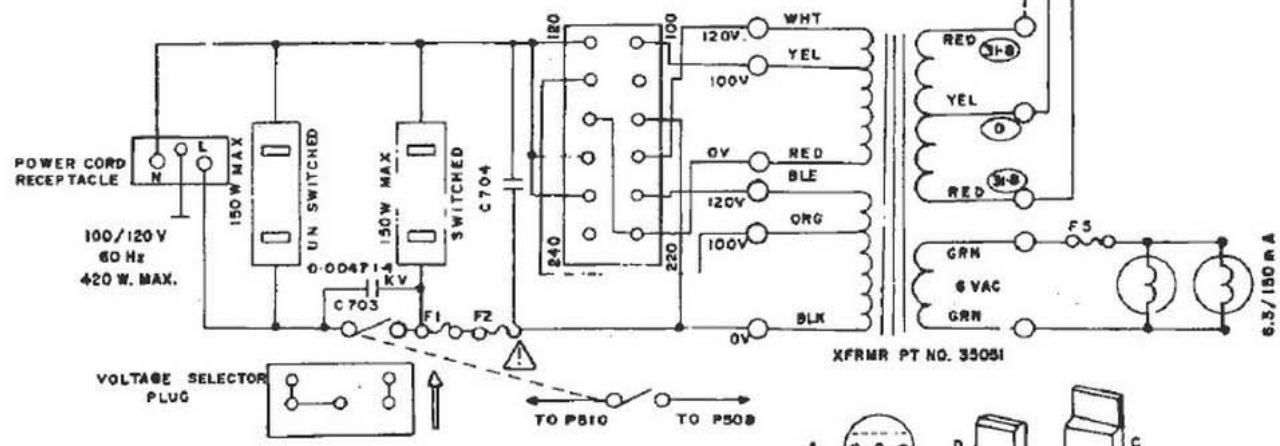
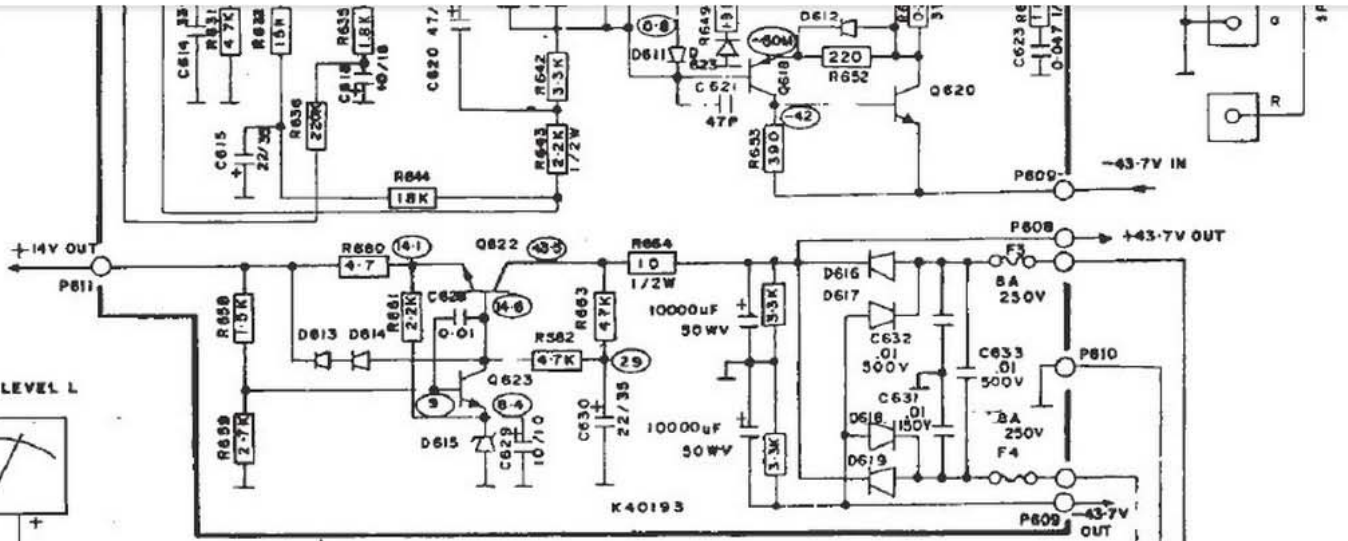
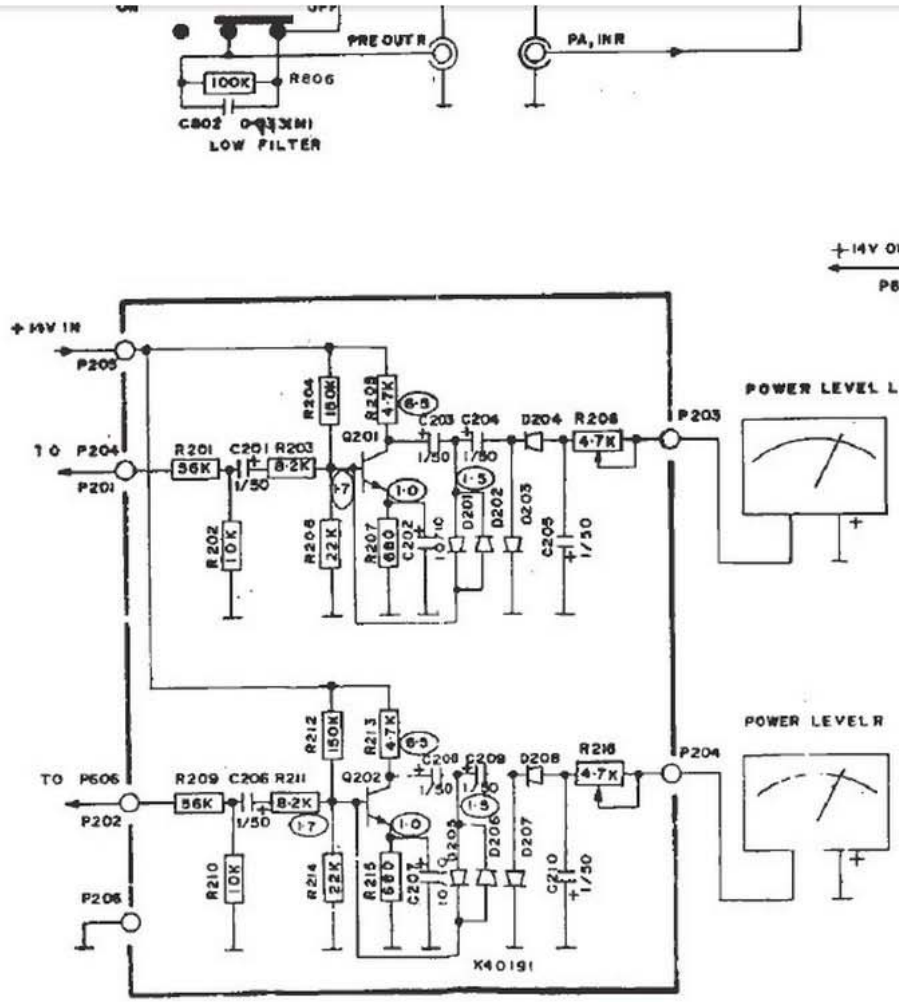

- Q101, Q103, Q301, Q302, Q501, Q502, Q503, Q504 --- 2SC 732BL (A) OR MPS 9633C/D (B)
- Q102, Q104 --- 2SA 494 OR (A) OR 2SA 842 GR/BL (A)
- Q505, Q506, Q507, Q823, Q201, Q202 --- CS 9013HG (B) OR MPS 9632 I (B)
- Q601, Q602, Q68, Q817 --- 2SC 1000 BL (A)
- Q621 --- CS 1861 (B) OR MPS A55 (B) 2SA 661 O (D)
- Q605, Q615 --- 2SC 372 (A) OR MPS 9630 U (B)
- Q606, Q616 --- 2SA 495 (A) OR MPS 9680 U (B)
- Q804, Q614 --- MPS 9630 K (B)
- Q822 --- 2SD 234 (C) OR TIP 318 (C)

- Q607, Q617 --- 2SC 16280 (C)
- Q608, Q618 --- 2SA 8160 (C)
- Q609, Q610, Q619, Q620 --- 2SD 428 O (E)
- D10, D102, D615 --- CD0044 OR MA 1091
- D601, D602, D603, D604, D605, D606, D607, D608, D609 --- CDG 24 OR MA 150
- D610, D611, D612, D613, D614, D201, D202, D205
- D206
- D203, D204, D207, D208 --- IN60 PAIR
- D616, D617, D618, D619 --- 3R 3AM OR P300D
- Q803, Q813 --- 2N6400 OR 2N6401

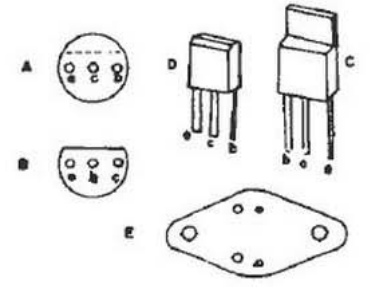

F1 4A/125V STD — 0.0047/150V AC 0.0047/150 VAC  
 CANADA 4A/125VMB 5A/125VMB 0.0047/125V AC 0.0047/150 VAC  
 EUROPE 2A/250V STD — 0.0047/250V AC 0.0047/250 VAC  
 F5 #38 SWG COPPER WIRE

PRODUCT MFG'D BY FACTORY NO.1,  
 IDENTIFIED BY S/N SUFFIX KC OR KD.  
 THIS SYMBOL INDICATES A SAFETY CRITICAL COMPONENT.