

LEFT CHANNEL

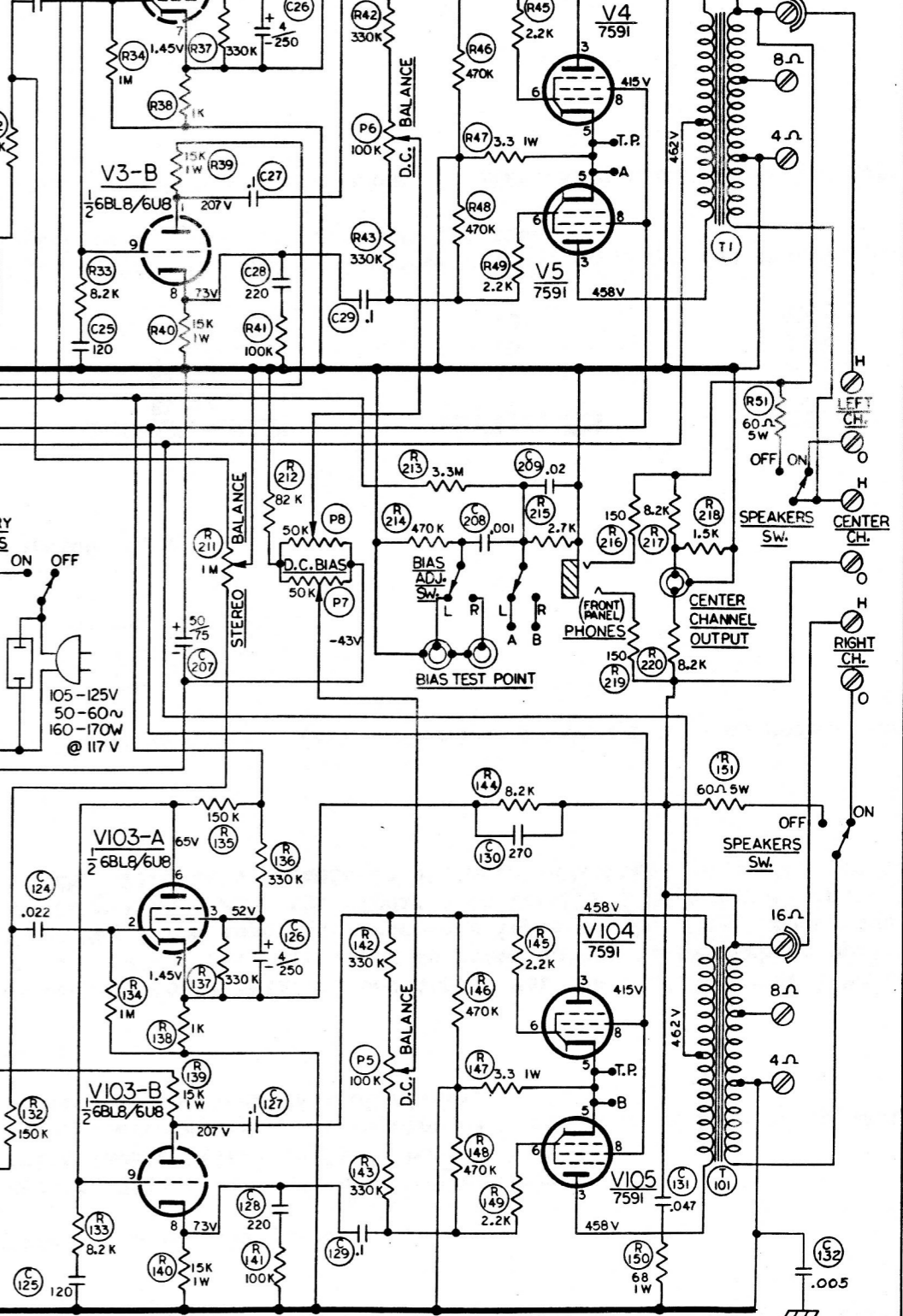
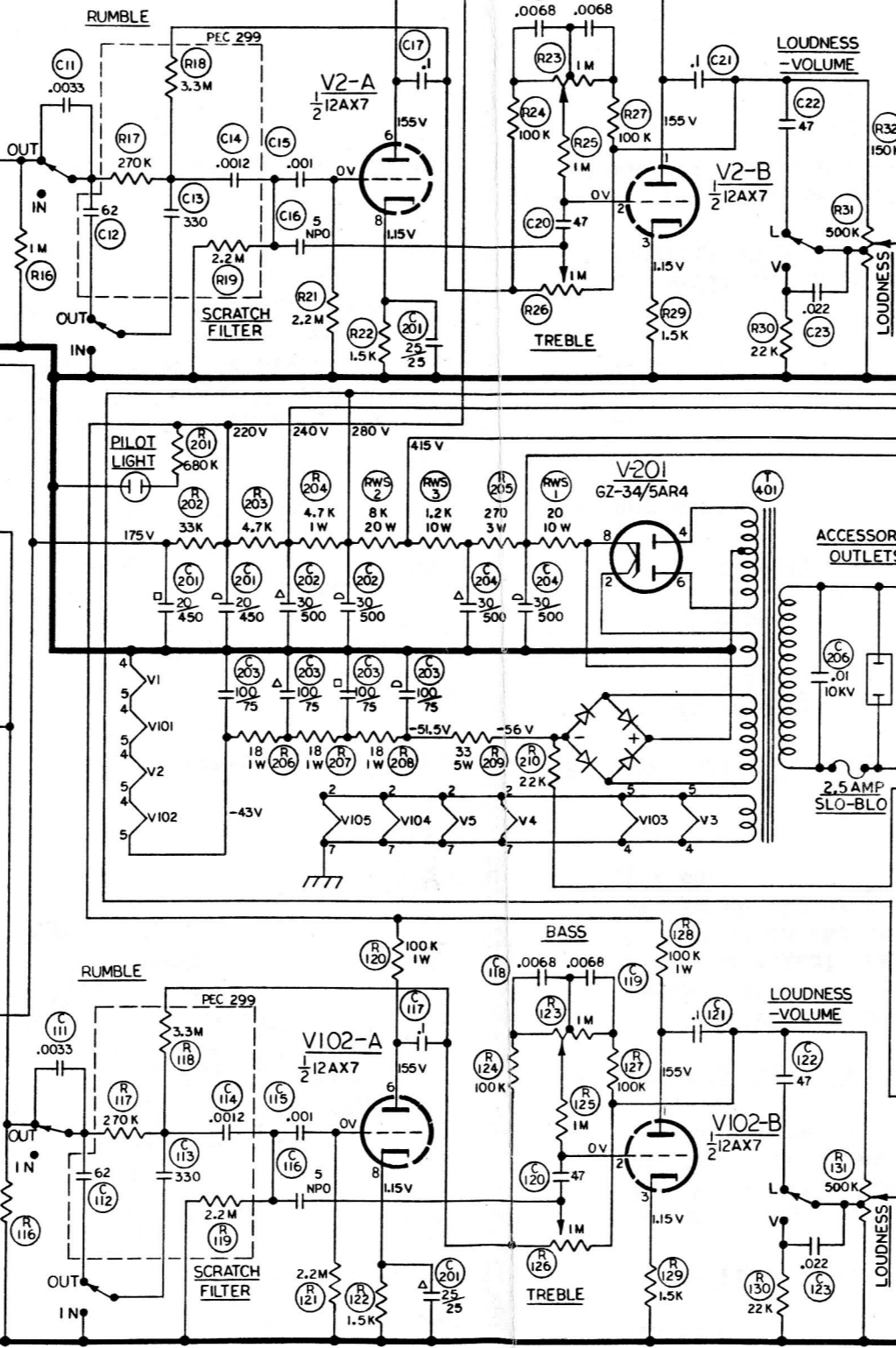
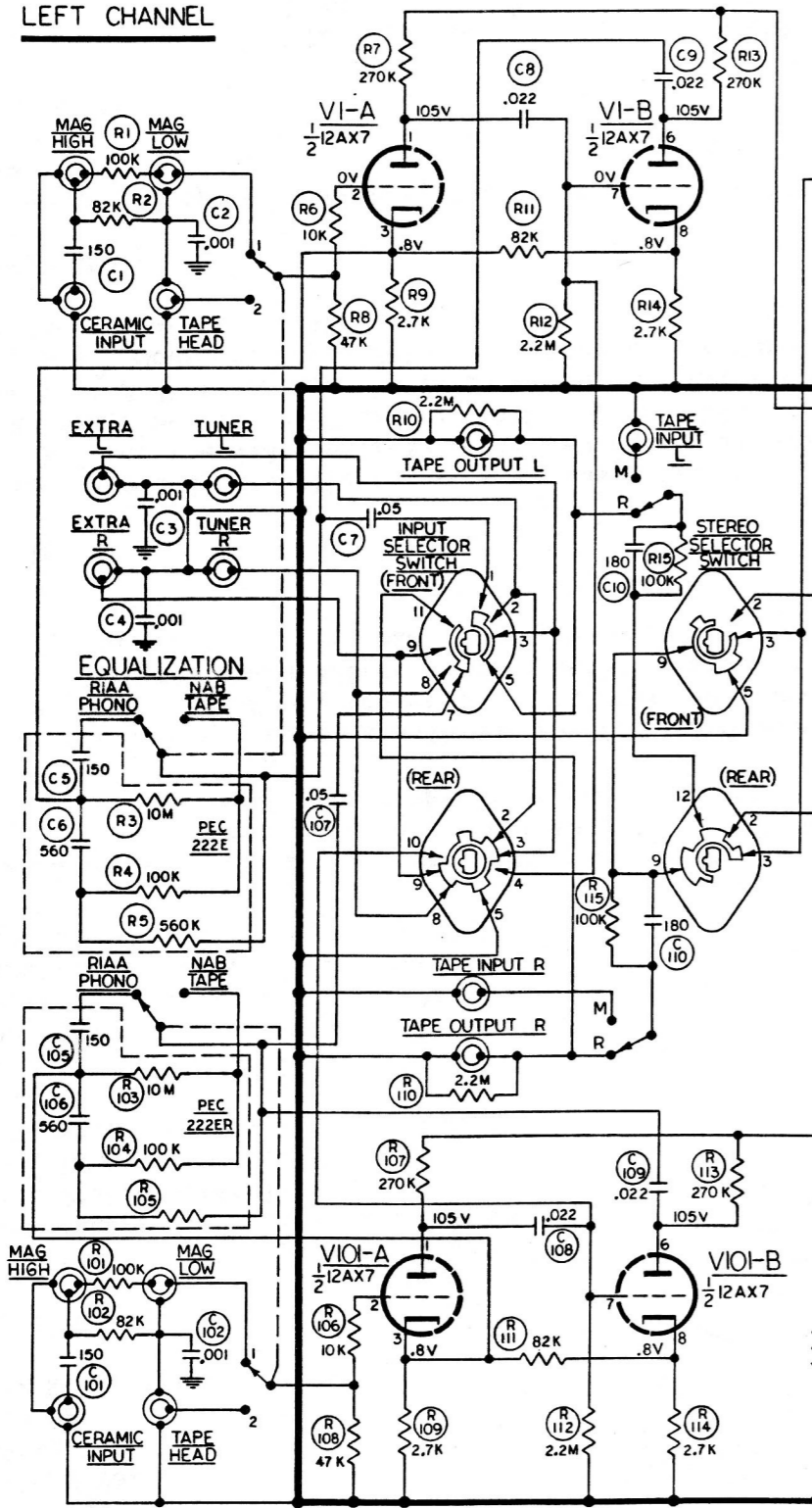

RIGHT CHANNEL

INPUT SELECTOR

POSITION	FUNCTION
1	PHONO
2	TUNER
3	EXTRA

STEREO SELECTOR SW.

POSITION	FUNCTION
1	BALANCE L
2	BALANCE R
3	MONOPHONIC RECORDS
4	STEREO
5	REVERSE STEREO
6	LEFT INPUT
7	RIGHT INPUT

EQUALIZATION SW.

POSITION	FUNCTION
1	RIAA-NARTB-ORTHO
2	NAB TAPE

THE FOLLOWING CONTROLS IN LEFT CHANNEL ARE MECHANICALLY GANGED WITH IDENTICAL CONTROLS IN RIGHT CHANNEL

- 1-INPUT SELECTOR
- 2-SCRATCH FILTER
- 3-RUMBLE FILTER
- 4-LOUDNESS AND POWER SW.
- 5-SPEAKER SW.