

price \$6.00

SERVICE MANUAL

solid state integrated stereo receivers

R33AS

R36AS

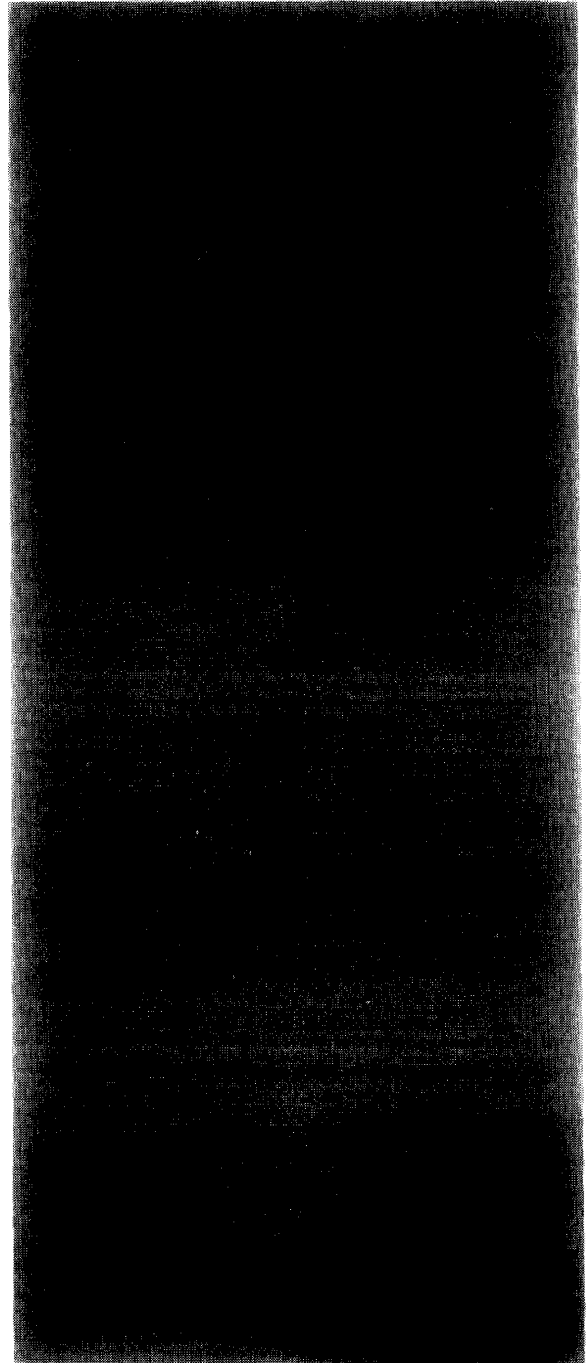
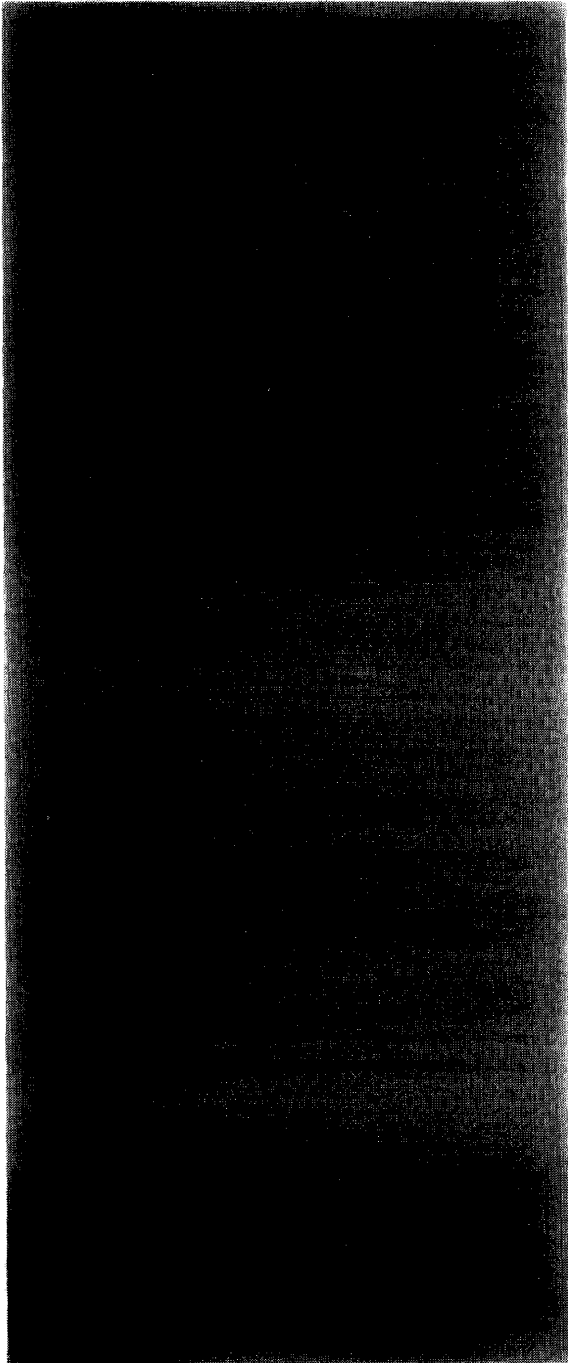

SCOTT®

where innovation is a tradition

H. H. SCOTT, INC., 111 Powder Mill Road, Maynard, Massachusetts 01754 Tel. 617 897-8801

TABLE OF CONTENTS

	Page
Audio Test Procedure -----	2
FM Test Procedure -----	5
AM Test Procedure -----	7
Trouble Shooting Guide -----	9
R-33S Circuit Diagram -----	11
R-36S Circuit Diagram -----	12
FM Front End -----	13
FM IF Amp -----	14
FM Multiplex Amp -----	15
AM IF Amp -----	16
AM Front End -----	17
DC Regulator -----	17
Preamp -----	18
Tone Amp -----	19
R-33S Power Amp -----	20
R-36S Power Amp -----	21
Dial Cord Stringing -----	22

AUDIO TEST PROCEDURE

Equipment Required

Audio Oscillator (H.P. 200CD or equivalent)

THD 0.25% maximum

Frequency Range 20Hz - 20KHz min.

AC Voltmeter (H.P. 400CD or equivalent)

Range 3mV - 30V rms minimum

Volt-Ohm Meter (Triplet Model 630 or equivalent)

20,000 Ohms per Volt DC

20 Ohm internal resistance on 12mA range

Harmonic Distortion Analyzer (H.P. 331A or equivalent)

Oscilloscope (RCA W091A or equivalent)

Two 8 Ohm Resistive Loads

Minimum of 30W dissipation

Variable Transformer or 120V regulated line

Set Controls as Follows

Input Selector - "EXTRA"

Mode Switch - "STEREO"

Tone Controls - Flat

Volume - Minimum

Balance - "0" Center

Speaker Switch - Spkr 1 - "ON"; Spkr 2 - "OFF"

Power Switch - "OFF"

Comp Switch - "Volume"

1. Resistance Checks

Check both sides of power cord to chassis - Read 650K Ohms
With negative lead on chassis, measure collector resistance.

R33 - Q609 and Q610 - Approx. 7K Ohms
R36 - Q641 and Q661 - Approx. 7K Ohms

2. Power On Voltages

Supply Voltage

R33 - +52V DC
R36 - +65V DC

Driver Balance

R33 - Collector of Q611 and Q612 - +26V DC
R36 - Terminals 8 and 15 - +32V DC

Voltage Regulator

Pin 7 should be +13V - Adjust VR801 if necessary

Driver Bias Adjustment (using Triplet 630 VOM on 12mA range)

R33 - Adjust VR603 and VR604 for 0.5mA across R627 and R628 respectively.
R36 - Adjust VR601 and VR621 for 0.8mA across R642 and R662 respectively.

3. Amplifier Measurements

Connect Audio Oscillator at 1,000Hz to left "Extra" input. 0.5V +2dB
Connect 8 Ohm loads to "Spkr 1" terminals. Turn volume control to maximum. Observe output level.

R33 - 12.6V rms (20 Watts)
R36 - 15.5V rms (30 Watts)

Repeat for right channel.

Push mode switch to "Mono". Increase input until output starts clipping.

R33 - Adjust VR601 for symmetrical clipping of left output
Adjust VR602 for symmetrical clipping of right output
R36 - Adjust VR602 for symmetrical clipping in both channels

Measure harmonic distortion

Should be less than 0.5% at rated output both channels
Return mode switch to "Stereo" position

4. Tone Control Check

Adjust input for 0dB output (.78V)

	<u>Bass 100Hz</u>	<u>Treble 10KHz</u>
--	-------------------	---------------------

Boost	10 +2dB	Boost	10 +2dB
Cut	10 +2dB	Cut	10 +2dB

5. Frequency Response - at 0dB output

+1dB 25 to 15KHz
3dB down points 17Hz and 25KHz

6. Noise Filter Check - at 10KHz

Note drop of 10 +2dB with filter "In"

7. Comp Switch Check

Adjust input for 0dB output with volume control at 10 O'Clock
Reference 1KHz

Comp switch at	<u>Volume</u>	<u>Loudness</u>
	100Hz 0dB	100Hz +10 <u>+2dB</u>
	10KHz 0dB	10KHz +2 <u>+1dB</u>

8. Pre Amp Gain Tests

Attenuate input 46dB from level in step 4
Connect input to "Phono" and switch selector to "Phono"
Volume at maximum. Note output of 0 +2dB at 1KHz.

Response Check

1KHz	0dB (reference)
10KHz	-13 <u>+2dB</u>
100Hz	-13 <u>+2dB</u>

9. Hum and Noise Measurements

<u>Position</u>	<u>Volume</u>	<u>Input</u>	<u>Output (hum & noise)</u>
Extra	Min.	Open	3mV
Extra	Max.	Open	5mV
Phono	Max.	Shorted	15mV

Repeat steps 4 to 9 for right channel

FM TEST PROCEDURE

Equipment Required

Vacuum Tube Voltmeter	H.P. 400D	
Oscilloscope	RCA W091A	or
Volt-Ohm Meter	Triplett 630	equivalent
Distortion Meter	H.P. 331A	
FM Generator (or source)	Measurements Mod. 88	
MX Generator (or source)	Scott Mod. 830	
Audio Generator (or source)	H.P. 200CD	

Set Controls to the Following

Input Selector Switch	FM
Muting	OFF
Mode	STEREO

Preliminary Checks

Inspect unit for defects, such as broken wafers, cracked terminals and jacks, loose transformers, binding tuning condenser, broken components, lead dress, scrap in unit, etc. Make certain all transistors are firmly seated in correct sockets.

Take output from tape out jacks.

Switch unit on, check voltage at power supply board.
Terminal 8 should measure +12 +1V.

1. Mono Alignment and Sensitivity Check

Front End and IF Alignment

With about 10 uV generator output, align and peak front end for maximum output.

With 3 uV input, align IF's for maximum audio. (IF's are pre-aligned, adjust only if repairs are made which dictate realignment)

With 1 or 2K uV input, align detector for minimum distortion, (0.5% or less). On R36 adjust top slug of detector for meter centertune on hash. Adjust bottom slug for minimum distortion.

2. Sensitivity and Distortion

Measure sensitivity of tuner with 2.2 uV RF input. Must obtain 30dB usable sensitivity at 92, 98, and 106 MHz.

Recheck distortion, 2K uV input. 400Hz - maximum distortion of 0.5%.
Audio output 1.5V +2dB.

3. FM Hum Check (1.0mV on antenna terminal)

Switch modulation OFF, measure minimum of 65dB reduction of output.

4. Deemphasis Check (1.0mV on antenna term.)

Tune to 92 MHz (change mod. to 8.2 kHz), note decrease of 12 \pm 2dB in output.

5. Calibration Check

Check calibration against stations - max. tolerance \pm 0.2 MHz.

6. Multiplex Alignment

- a. Connect audio oscillator, tuned to 67 kHz, to input (term. No. 1 & GND) adjust T302 for minimum indication at TP-2 as observed on oscilloscope.
- b. Tune front end to stereo signal and adjust T301 for straight base line of composite signal when observed on oscilloscope using low capacitance probe.
- c. Move probe to TP-1, peak T303 and T304 for max. 19 kHz.
- d. Move probe to TP-3 and adjust T305 for max. 38 kHz.
- e. Adjust T305 for 40dB separation at TAPE OUTPUT JACKS, slight touch-up of T303 and T301 is permitted to obtain rated separation.
- f. Check stereo distortion (1.0mV input) max. 0.7%

7. Centertune, Muting and Stereo Threshold Adjustment

- a. Tune front end to mono signal, (1.0mV input), max. meter indication, check harmonic distortion which must be 0.5% or less. (DO NOT READJUST TUNING FOR BALANCE OF ITEM No. 7 ADJUSTMENTS). If necessary, adjust detector T203 and T204 for centertune indication on meter of R36 - Recheck harmonic distortion.
- b. Adjust VR201 for unit to switch from the MUTED condition (push-button IN) with 2.5-7uV on antenna terminals.

8. Final Listen Check

Check all inputs and outputs (including phone jack), switches, and controls for proper operation. Check over-all appearance and for scrap inside unit. Check for proper switching of stereo light and squelch circuit. Check calibration against stations - specs are within 0.2MHz. Perform factory dielectric test. (1100 vac between chassis and power transformer primary).

AM TEST PROCEDURE

1. 455 kHz Alignment

Set tuning to middle of AM band, 1000 kHz. Output from Left Tape Out jack. Input from 455 kHz generator to AM loop antenna. With 2mV or less generator output peak all IF coils, T101, T201, T202, T203, T204 and T205 for max. output, keeping input level as low as possible.

2. Oscillator Adjustment

With tuning condenser maximum capacity (fully closed) adjust pointer to "0" logging, left edge of dial.

Couple output of AM generator (600kHz modulated to 60% with 400Hz) to loop-stick with AM coupling loop.

Tune unit to 600kHz. Attenuate input of RF signal until signal level is just noticeable on scope (using maximum usable scope sensitivity).

Adjust oscillator coil (T102) for output peak, as read on VTVM.

Set AM generator to 1600kHz modulated to 60% with 400Hz.

Tune unit to 1600kHz. Adjust oscillator trimmer for maximum output, as read on VTVM, using weak RF input signal.

Repeat the above adjustments of oscillator coil and oscillator trimmer until no further improvement can be made.

3. Antenna Trimmer Adjustment

Set AM generator to 1400kHz modulated to 60% with 400Hz. Tune unit to 1400kHz. Adjust antenna trimmer (TC5) for maximum output, as read on VTVM, using weak RF input signal.

4. Tune to 600kHz and adjust ANT., tuning for maximum output.

5. AGC Potentiometer Adjustment

Tune unit to 1.0MHz. Couple output of AM generator to loop for 300mV/M. Adjust VR201 (on IF board) for OUTPUT VOLTAGE of 0.6 - 0.95 volts. Harmonic distortion must not exceed 0.9%.

6. Sensitivity Measurements

Tune unit and generator to 600kHz. With coupler installed in the "MEASUREMENTS" position, attenuator set for 22uV (-50dB).

Audio output must be between 0.3 and 0.6 volts.

7. Repeat above measurements at each 200kHz point above 600kHz and note that output measures between 0.3 and 0.6 volts.

8. Calibration

Check calibration at 200kHz intervals. Maximum calibration error shown in chart below. Using AM signal available at test bench attenuator.

Calibration

800 kHz	<u>+10</u> kHz
1000 kHz	<u>+20</u> kHz
1200 kHz	<u>+20</u> kHz
1400 kHz	<u>+10</u> kHz
1600 kHz	<u>+10</u> kHz

9. AM Final Listen

Using headphones plugged into the front panel phone jack and loudness control adjusted for adequate output, slowly tune across the AM dial, listening for oscillations and no output.

Remove shorting bar on external antenna. Connect outside antenna to unit. Check calibration and tuning meter indication, using stations. Remove outside antenna, replace shorting bar and tighten screws. Turn AC power off and remove headphones from unit. Remove all test cables.

TROUBLE SHOOTING GUIDE

<u>SYMPTON</u>	<u>LOCATION</u>	<u>CHECK</u>
No Power	Rear Panel	Power Fuse Power Cord
Blows Power Fuse	Driver Board	Q609, 610, 611, & 612 (R33) Q641, 642, 661, & 662 (R36)
	DC Regulator	D801 - 804 Shorted
	Chassis	C503 Leaky
No Output all positions Unit lights up	Rear Panel	Speaker Fuses
	Tone Control	B+ on pin 4 Q501 & Q521
	Driver Board	B+ and Balance Voltages C613 & C614 (R33) Open C641 & C661 (R36) Open
No Phono	Preamp Board	B+ on pin 5
	Input Switch	Check Continuity
No FM Normal Background Noise	Front End	+12V on pin 4 Q1, 2, 3, and 4 L1, 2, 3, 4, and 5
	FM IF Board	Q201
FM Completely Dead	FM IF Board	IC201 & IC202 Q205 & Q206 T202, 203, and 204 Check +12V on pins 2 and 10
	Multiplex Board	+13 on pins 3 and 7 +35 on pin 9 IC301 Q301, 302, and 303 T301 & T302
Poor FM Sensitivity	Front End	Alignment Q1, Q2 L1, 2, and 3
	FM IF Board	Q201, 202, and 203 IC201 & IC202
No FM Stereo	Multiplex Board	Alignment IC301 T303, 304, and 305
	FM IF Board	Q207 & Q208

<u>SYMPTON</u>	<u>LOCATION</u>	<u>CHECK</u>
No AM	AM Front End	AM Antenna loopstick Open Q101 & Q102 +12V on pins 3 and 5 T101 & T102
	AM IF Board	T201, 202, 203, 204, and 205 Q201 & Q202 D201 & D202

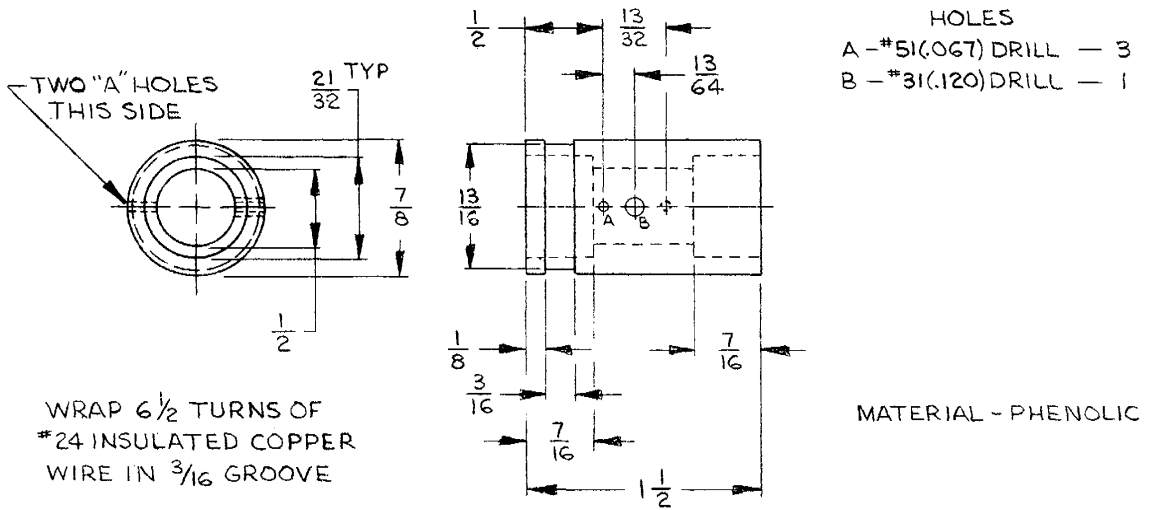

AM COUPLER

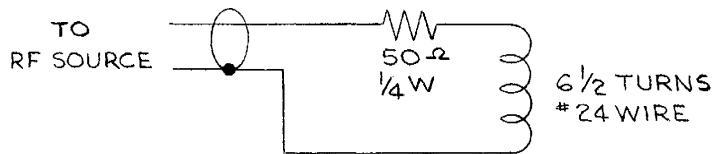

CIRCUIT DIAGRAM



LABEL

R33AS CIRCUIT DIAGRAM

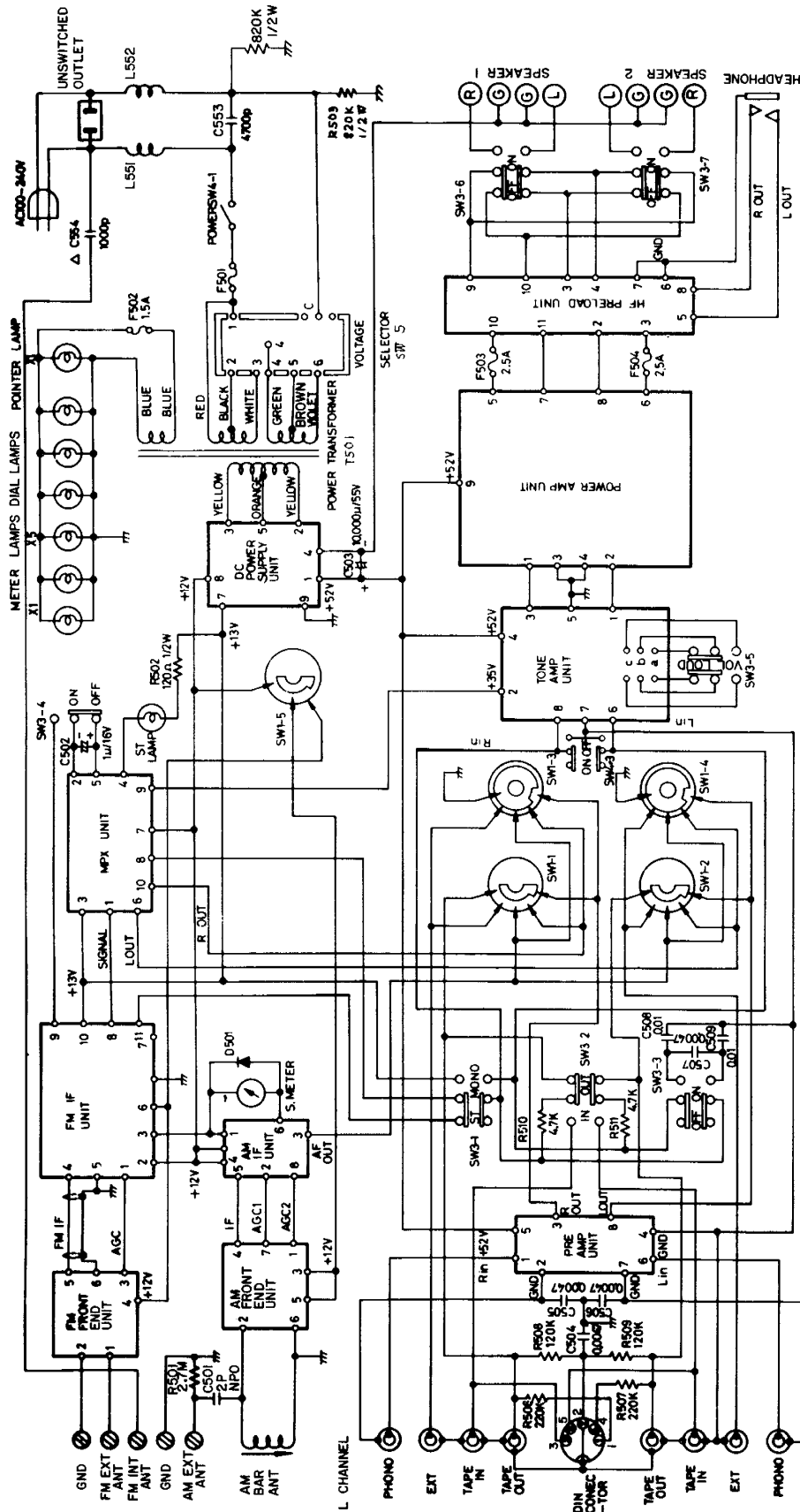

CAPACITOR Δ 400V AC
 UNLESS OTHERWISE SPECIFIED RESISTOR IN OHMS $\pm 10\%$ 1/4WATT
 AND CAPACITANCE IN μF

- PUSH SW
- SW3-1 STEREO-MONO
 - SW3-2 TAPE IN-OUT
 - SW3-3 HIGH FILTER
 - SW3-4 MUTING
 - SW3-5 LOUDNESS
 - SW3-6 SPEAKER 1
 - SW3-7 SPEAKER 2
 - SW4-1 POWER SW
 - SW4-2 POWER SW

- FUNCTION
- 1 PHONO
 - 2 FM
 - 3 AM
 - 4 EXTERNAL
 - 5 COMMON

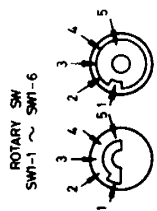

R36AS CIRCUIT DIAGRAM

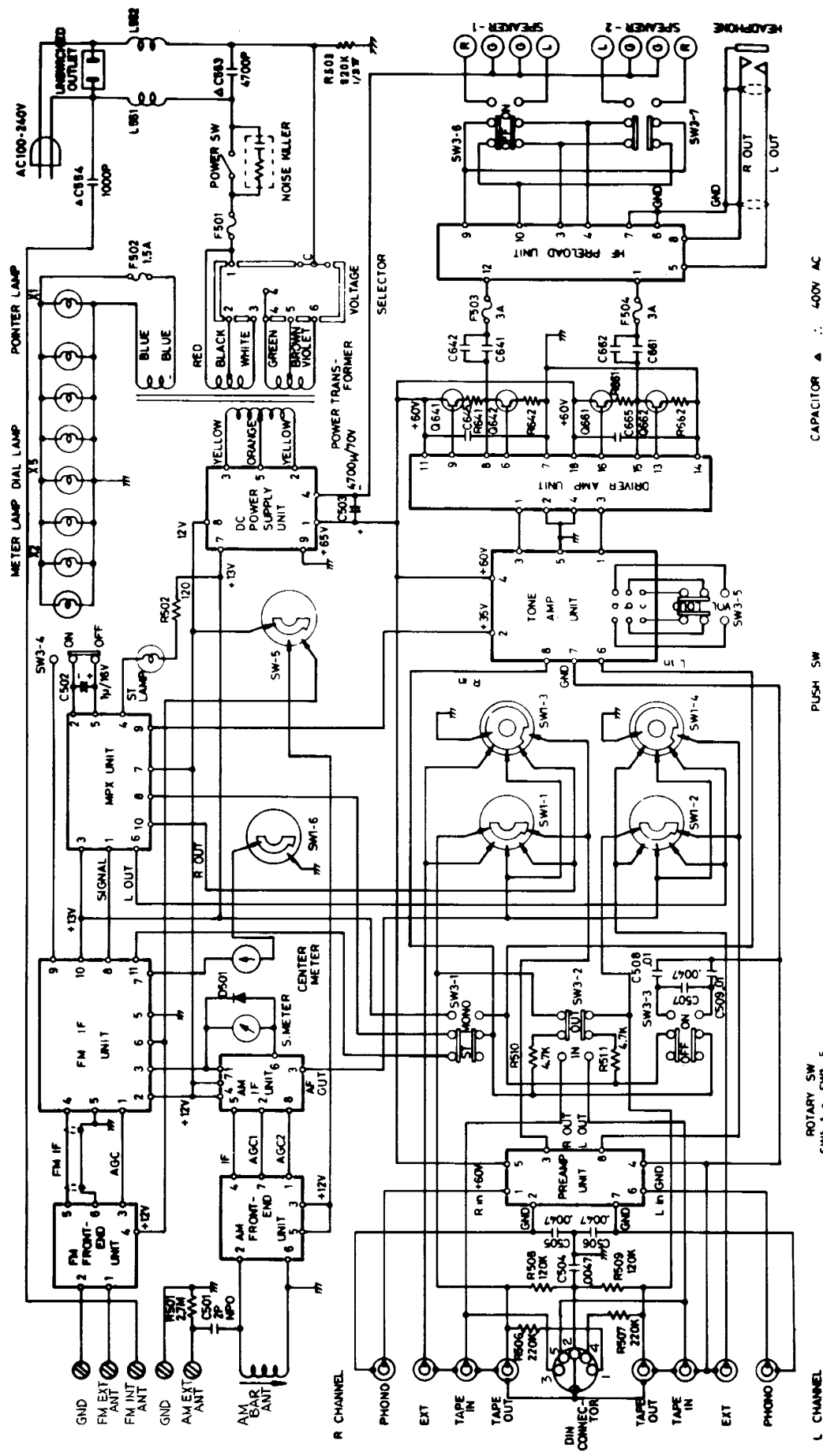

ROTARY SW
 SW1-1 ~ SW1-5

PUSH SW
 SW3-1
 SW3-2
 SW3-3
 SW3-4
 SW3-5
 SW3-6
 SW3-7

FUNCTION
 PHONO
 FM
 AM
 EXTERNAL
 COMMON

POSITION
 1
 2
 3
 4
 5

STEREO MONO
 TAPE IN - OUT
 HIGH FILTER
 MUTING
 LOUDNESS
 SPEAKER 1
 SPEAKER 2

CAPACITOR Δ ∴ 400V AC
 UNLESS OTHERWISE SPECIFIED RESISTOR IN OHMS 10% 1/8 WATT
 AND CAPACITANCE IN μF

FM FRONT END



(BOTTOM VIEW)

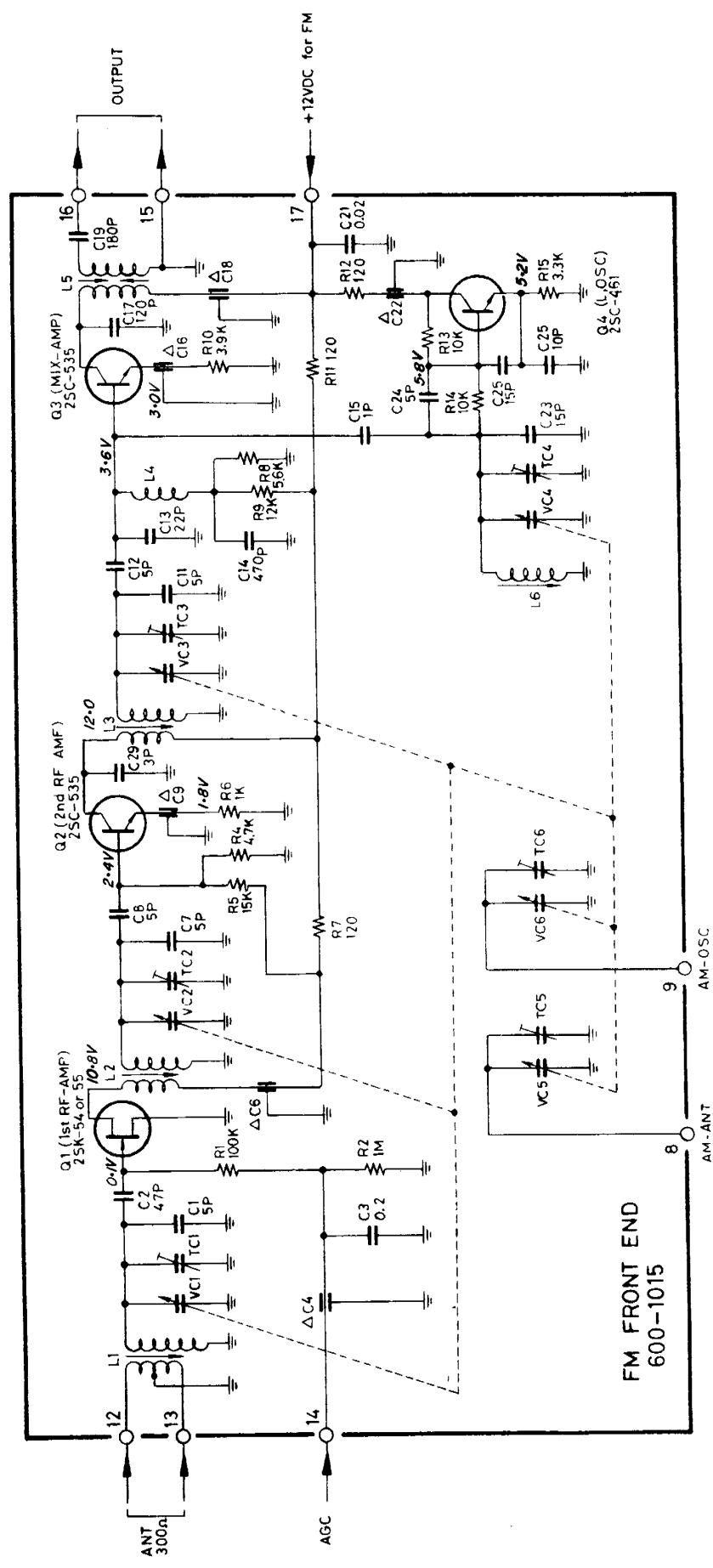

UNLESS OTHERWISE SPECIFIED, ALL RESISTOR IN OHMS, ±5%, 1/4WATT, Δ0.001μF ±20%, 50WV
 ALL CAPACITOR IN MFDS, 50WV.
ALL VOLTAGES ±10%

FM IF AMP.

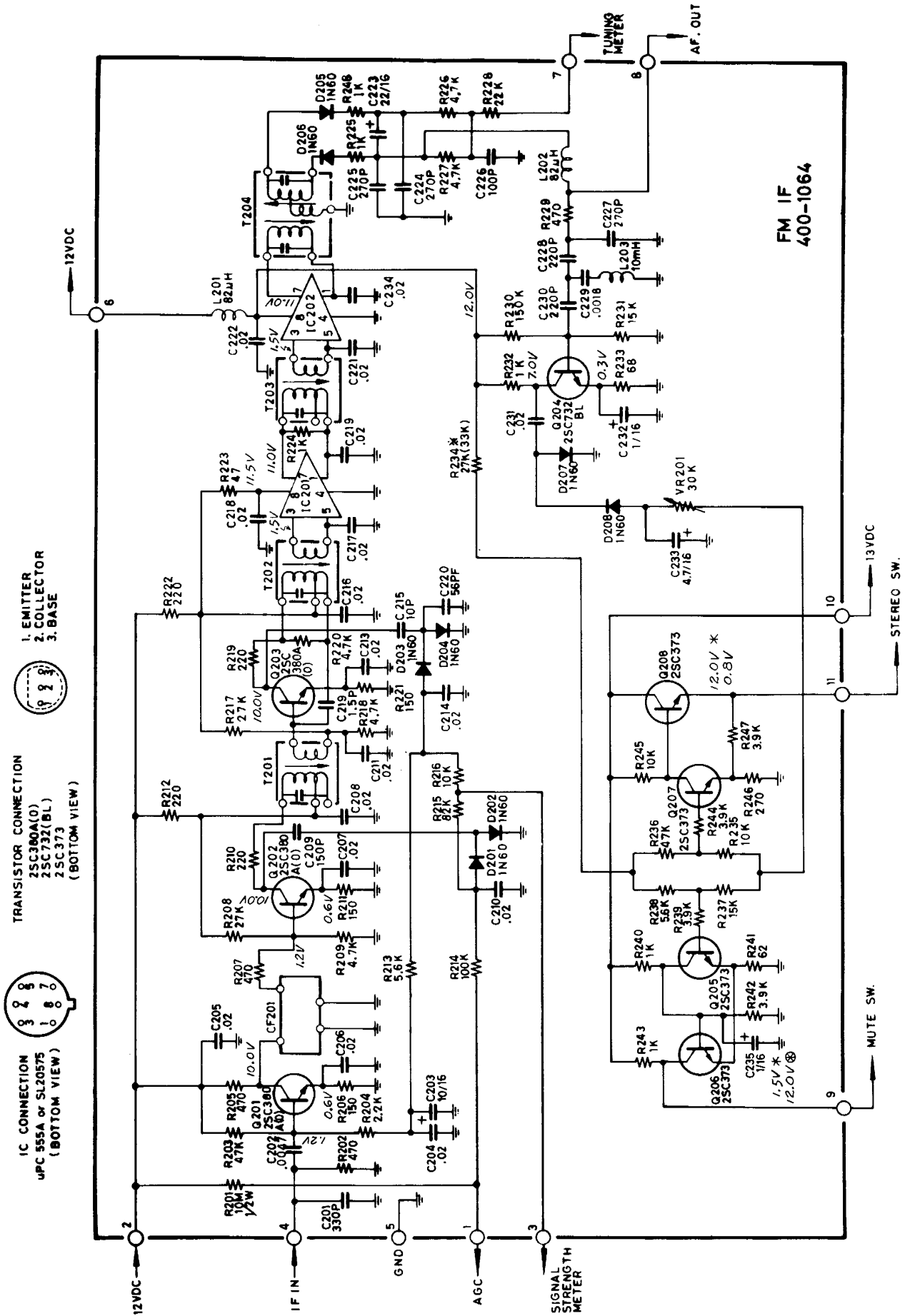

IC CONNECTION
 UPC 555A or SL20575
 (BOTTOM VIEW)

TRANSISTOR CONNECTION
 2SC380A(O)
 2SC732(BL)
 2SC373
 (BOTTOM VIEW)

1. EMITTER
 2. COLLECTOR
 3. BASE

- NOTES:
- UNLESS OTHERWISE SPECIFIED, ALL RESISTORS IN OHM, $\pm 10\%$, 1/4W, ALL CAPACITORS IN MFD, 50WV, VOLTAGES $\pm 10\%$.
 - * RF INPUT (MONO).
 - ⊗ MUTE SWITCH OFF.

FM MPX AMP.

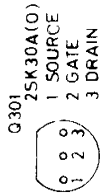
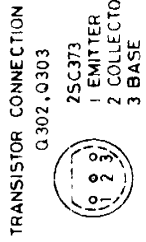
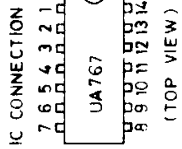

(TOP VIEW)

(BOTTOM VIEW)

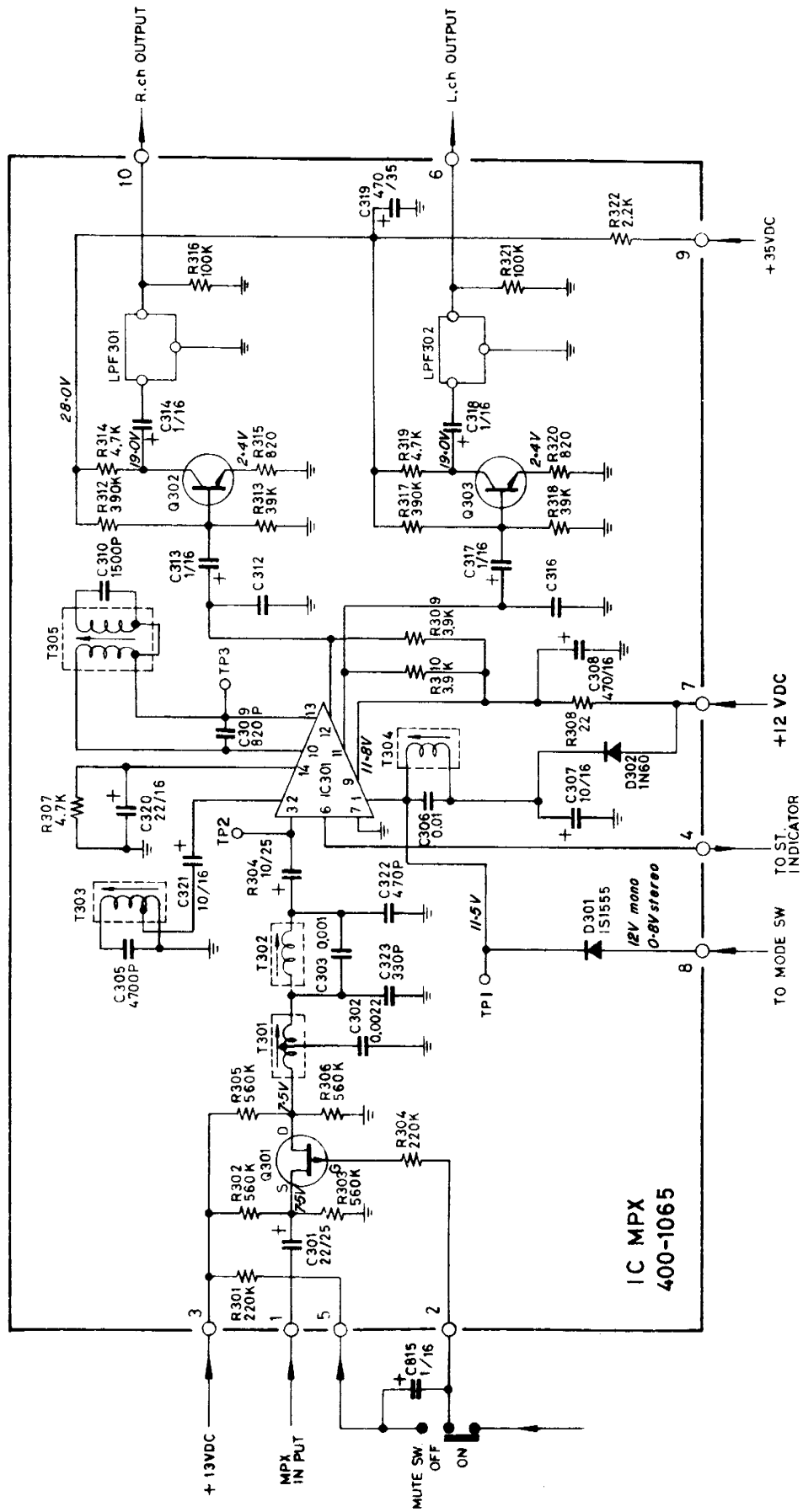

UNLESS OTHERWISE SPECIFIED, ALL RESISTOR IN OHMS, $\pm 5\%$, 1/4WATT, ALL CAPACITOR IN MFDS, 50WV, ALL VOLTAGES $\pm 10\%$

C312, C316 0.01 μ F (50 μ S) ; C317, C318 0.015 μ F (75 μ S) ;

AM IF AMP.

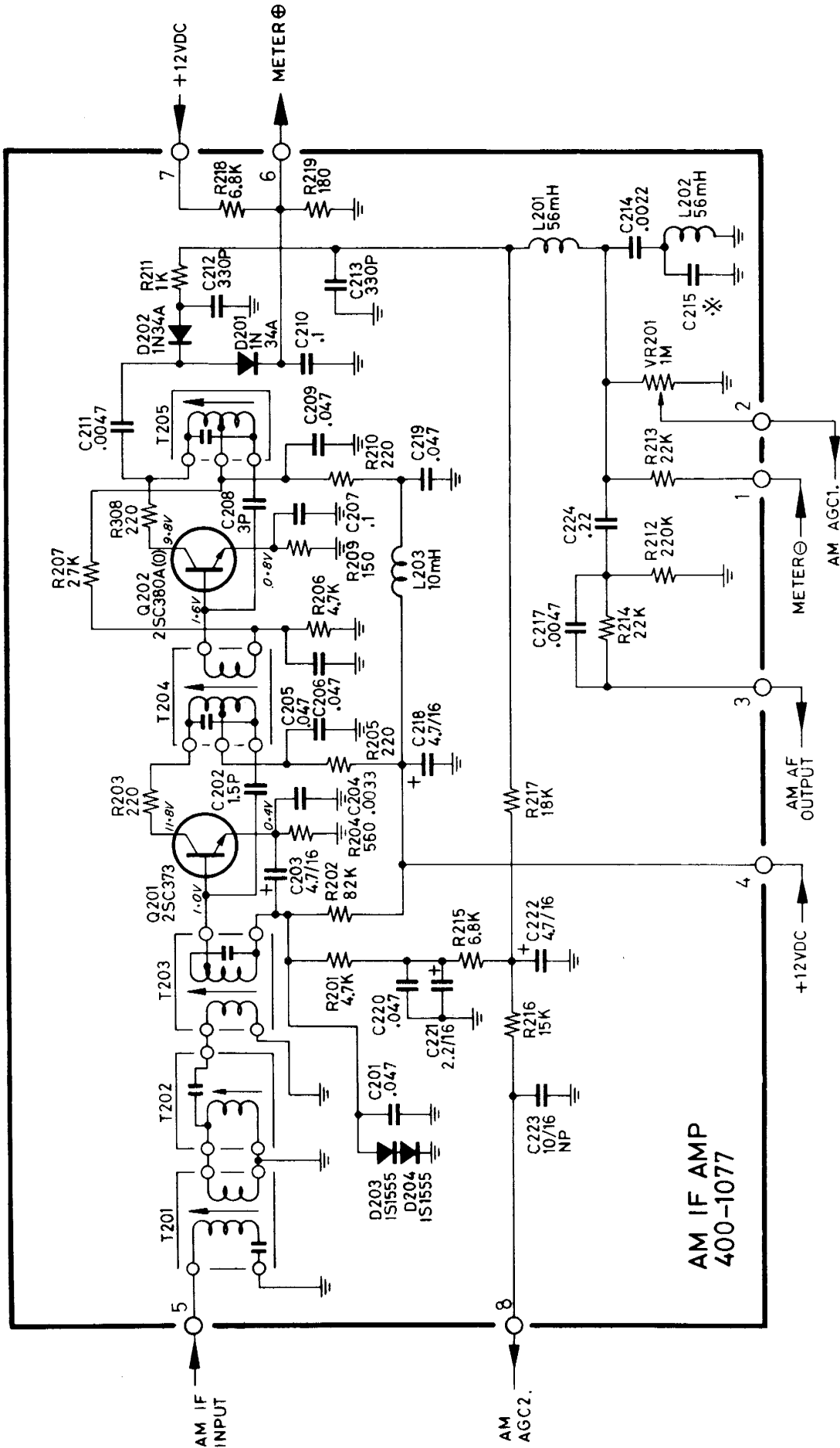

NOTE: UNLESS OTHERWISE SPECIFIED, ALL RESISTANCE IN OHMS, $\pm 10\%$, 1/4WATT, CAPACITANCE IN MFDS.

*-0.0022 μ F (for USA)
0.0033 μ F (for Europe)

ALL VOLTAGES $\pm 10\%$

TRANSISTOR CONNECTION
2SC373 1. EMITTER
2SC380A(0) 2. COLLECTOR
3. BASE



(BOTTOM VIEW)

AM FRONT END

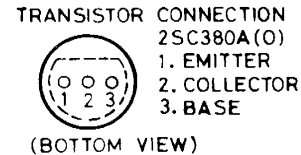
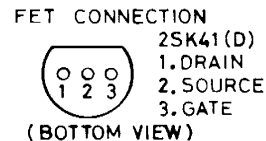
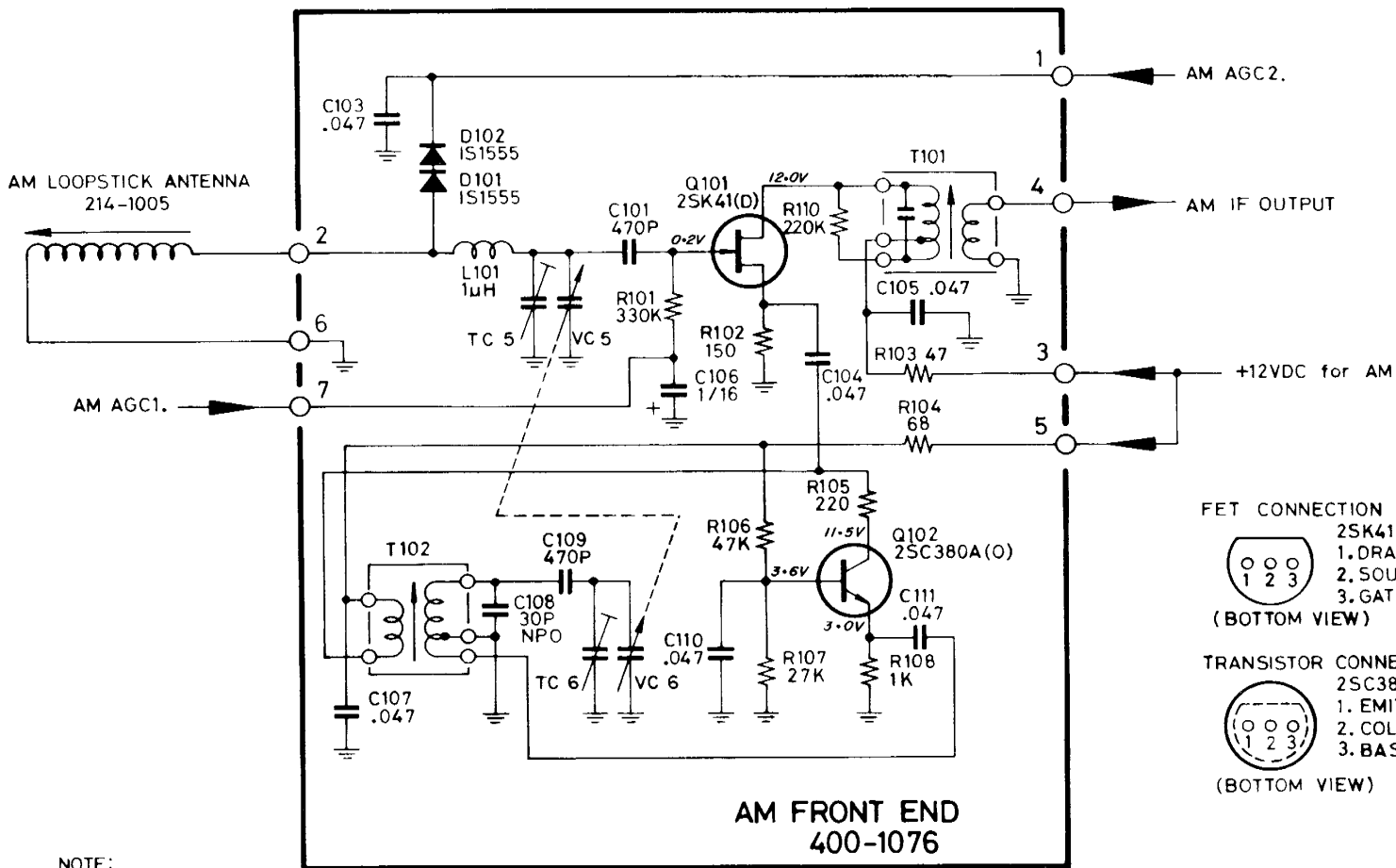

TRANSISTOR CONNECTION

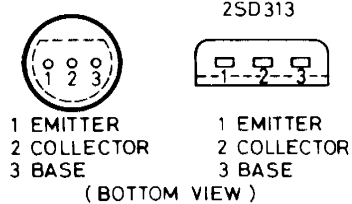

DC REGULATOR

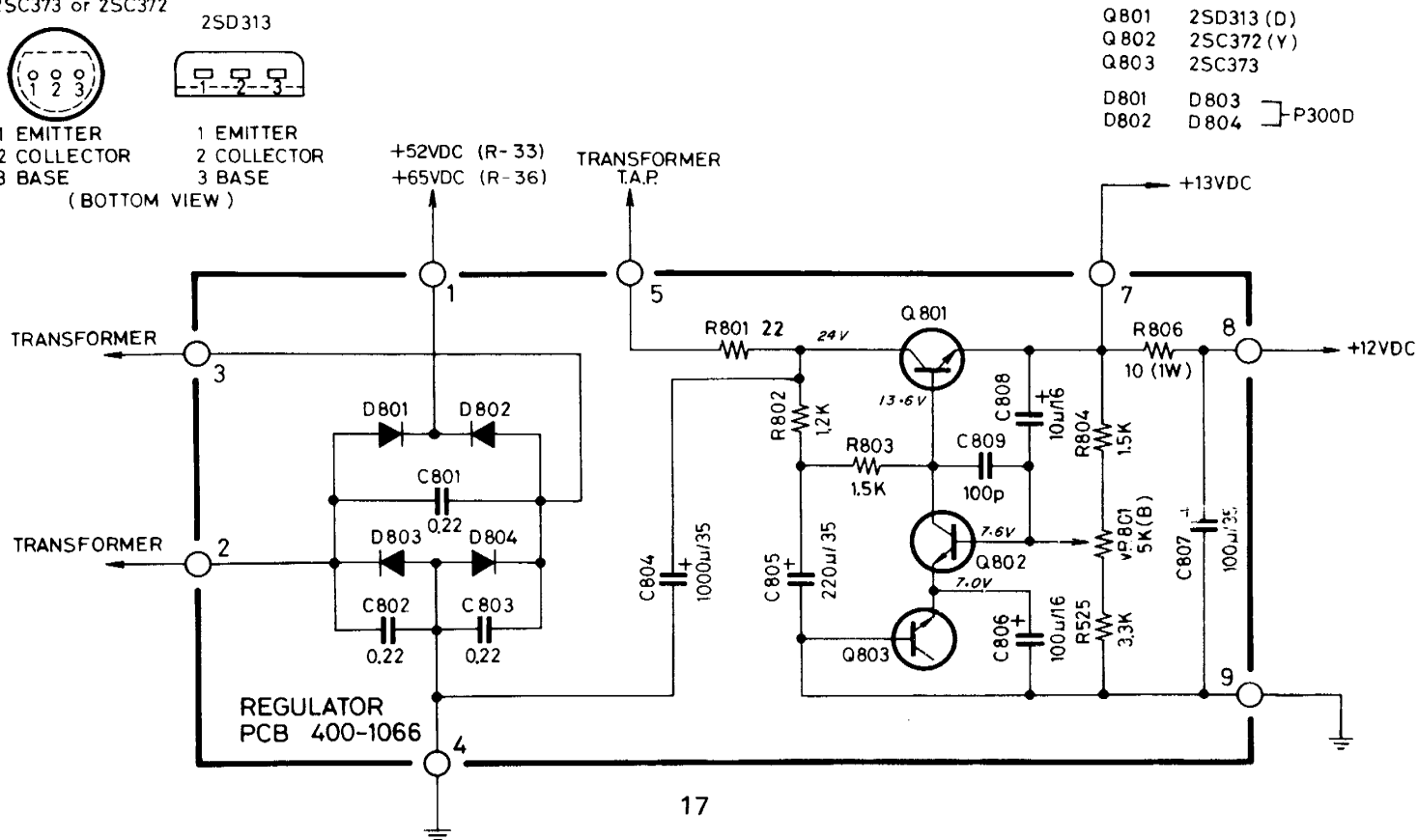

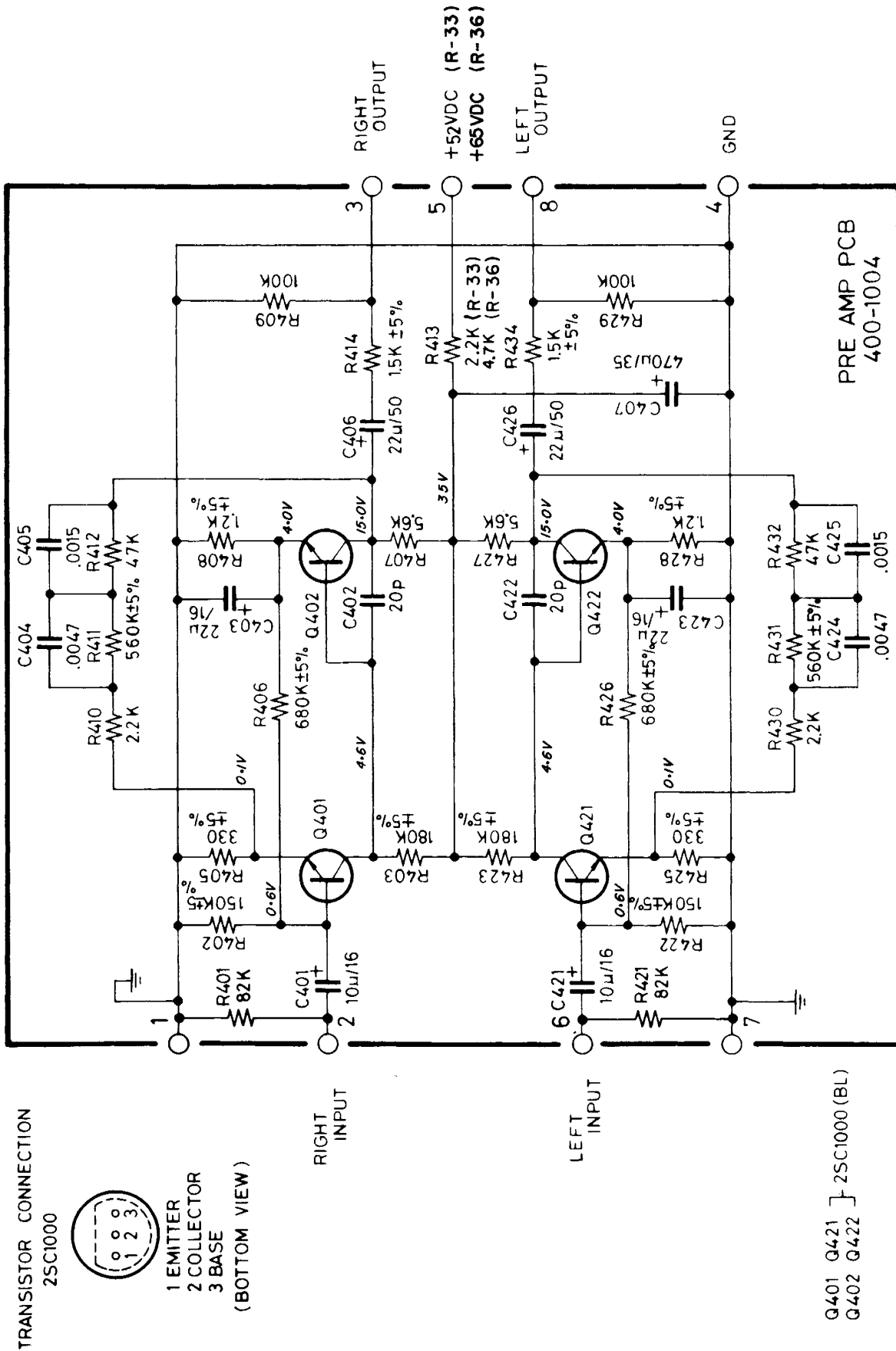

TRANSISTOR CONNECTION

2SC1000



1 EMITTER
2 COLLECTOR
3 BASE
(BOTTOM VIEW)

RIGHT INPUT

LEFT INPUT

Q401 Q421 } 2SC1000 (BL)
Q402 Q422 }

ALL VOLTAGES ±10%

TONE AMP.

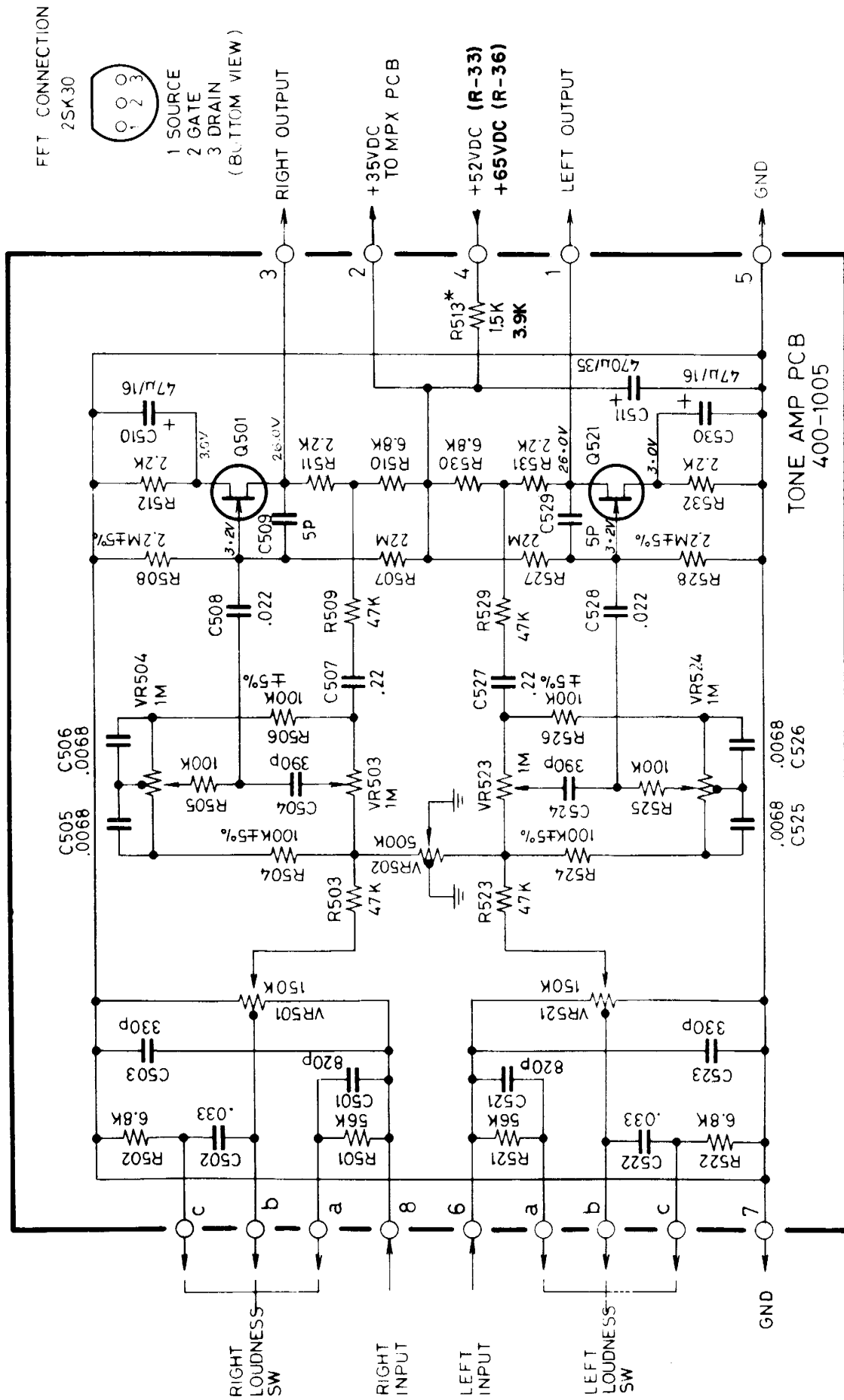

FFT CONNECTION
2SK30

1 SOURCE
2 GATE
3 DRAIN
(BOTTOM VIEW)

Q501 Q521 2SK30(O) or (Y)
* 1.5K R-33
3.9K R-36
ALL VOLTAGES ±10%

R33AS POWER AMP.

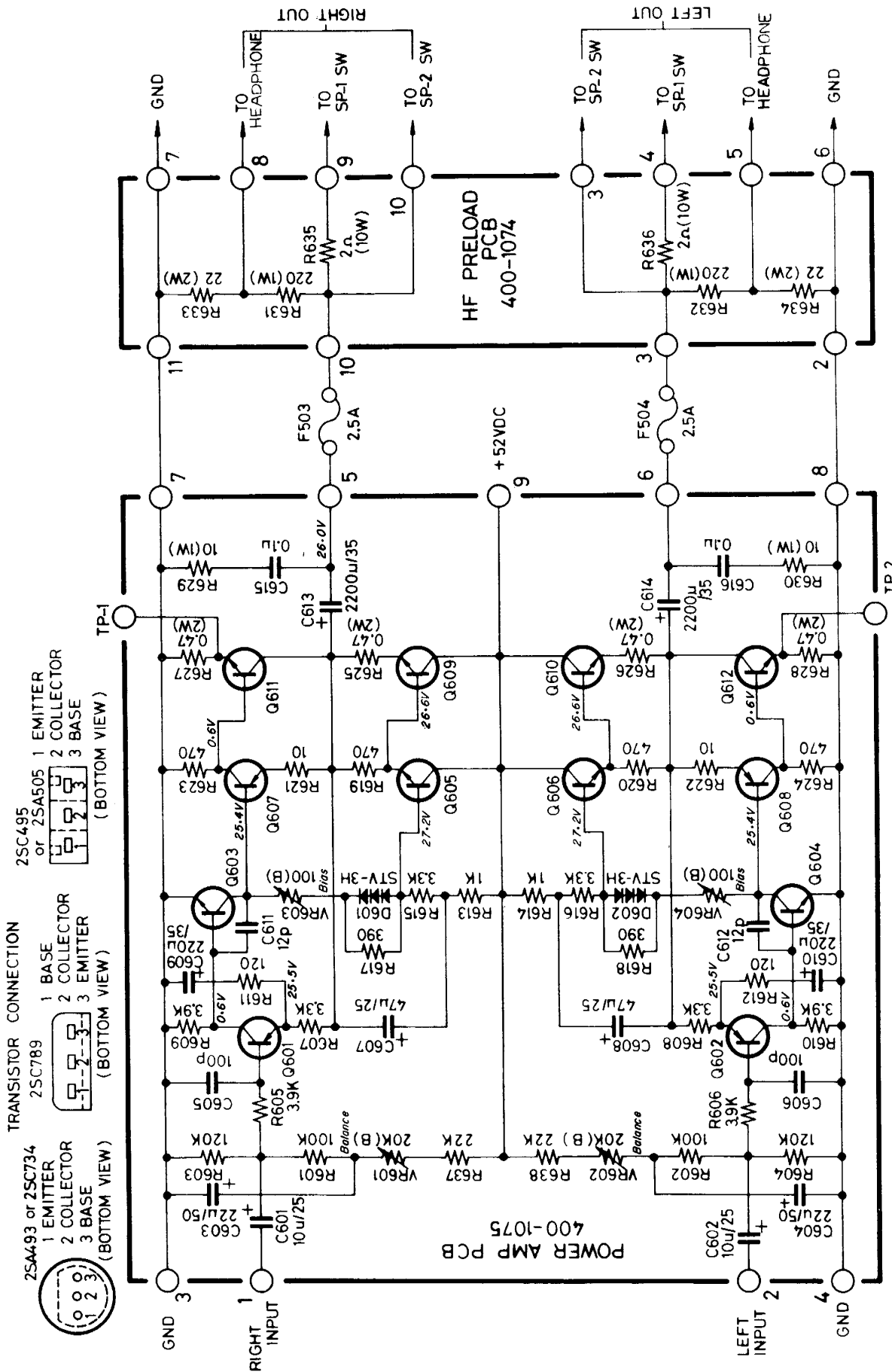

- Q601 Q602 25A493 (GR)
 - Q603 Q604 2SC734 (O)
 - Q605 Q606 2SC495 (O)
 - Q607 Q608 2SC505 (O)
 - Q609 Q610 J-25C789(O)
 - Q611 Q612
- ALL VOLTAGES ±10%

R36AS POWER AMP.

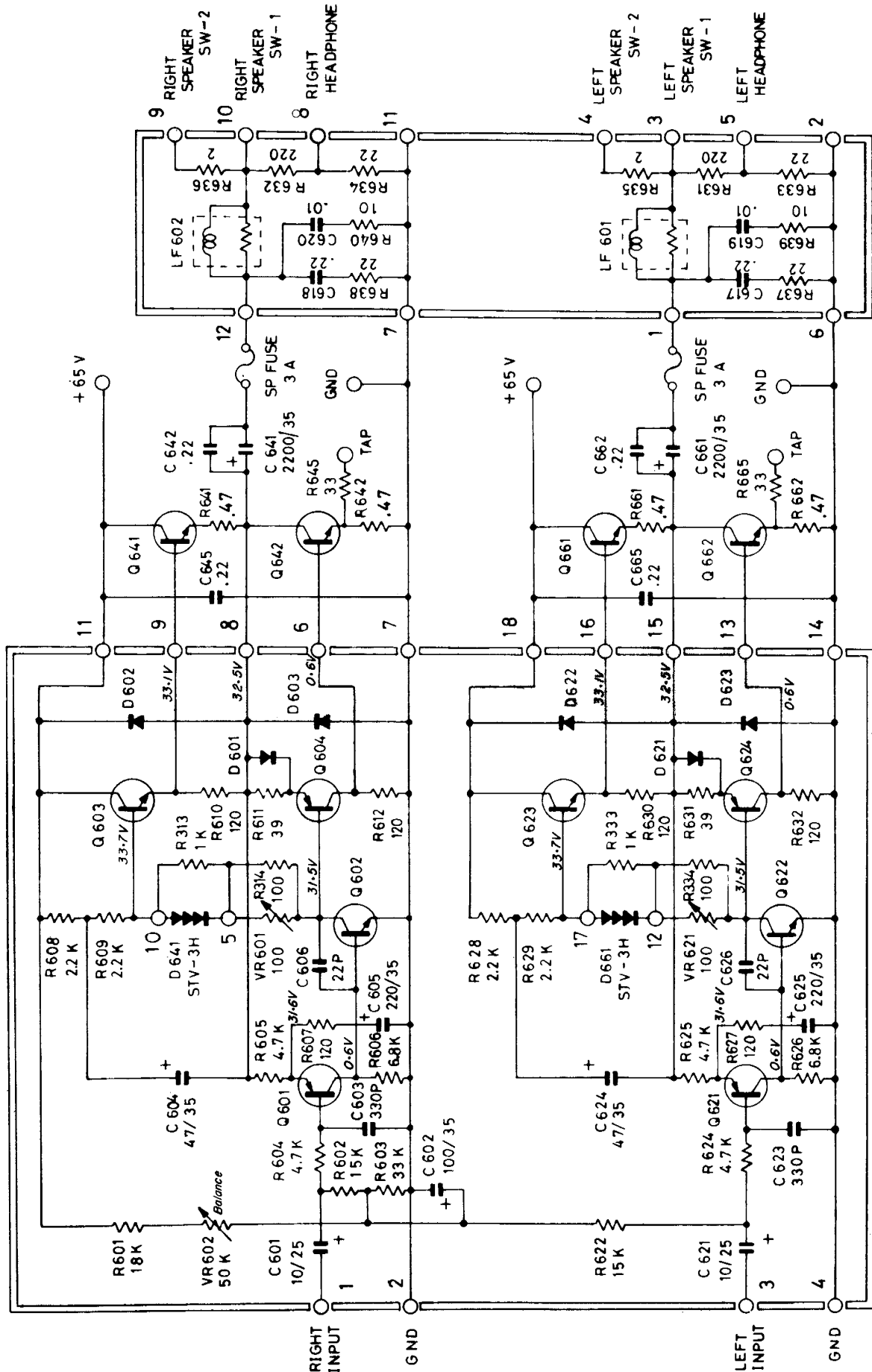

H F PRELOAD PCB UNIT

DRIVER PCB UNIT

NOTE : Q601, Q621 2SA561 Q602, Q622 2SC983 Q603, Q623 2SC1382
 Q604, Q624 2SA682 Q641, Q642, Q661, Q662, 2SD201
 D601, D602, D603, D621, D622, D623, RA-1Z

ALL VOLTAGES ±10%

DIAL CORD STRINGING

DIAL CORD RE-STRINGING PROCEDURE FOLLOW SEQUENCE 1 THRU 7

