

price \$8.00

SERVICE MANUAL

solid state integrated stereo receivers

R77S

R75S

R74S

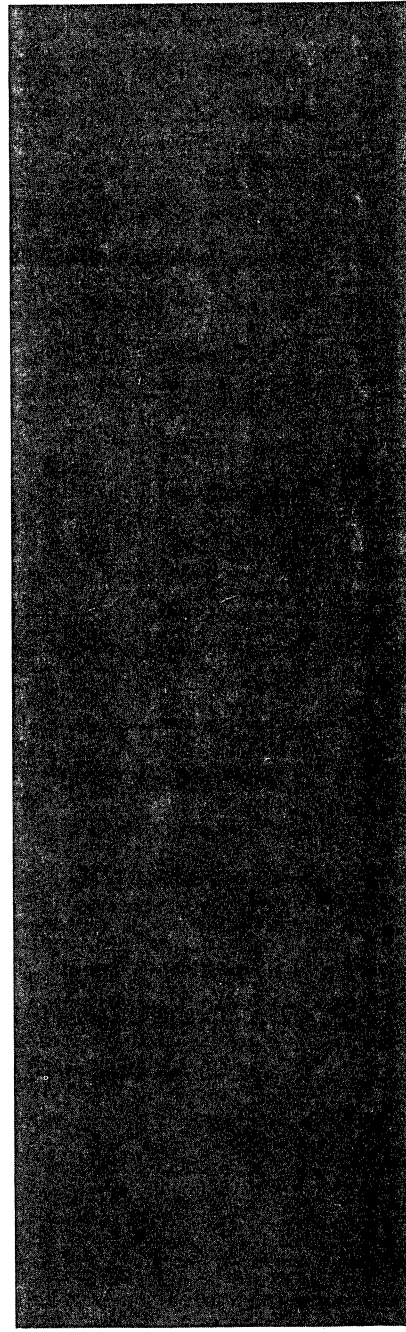
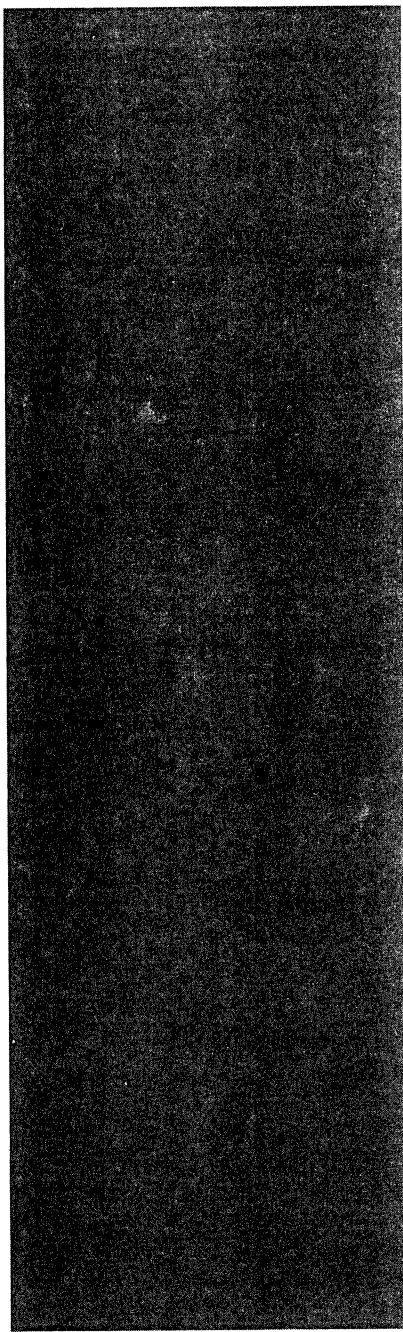
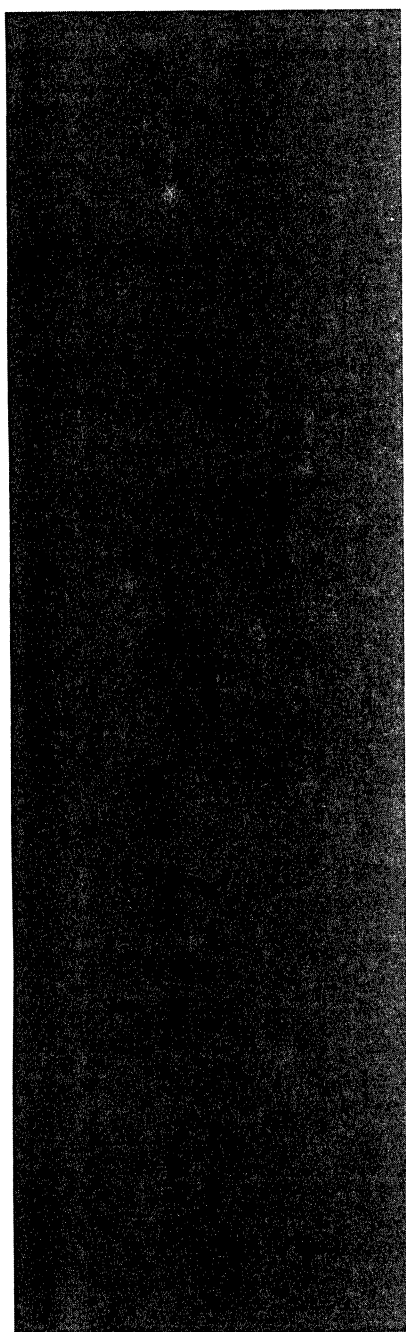

SCOTT® ...where innovation is a tradition

H. H. SCOTT, INC., 111 Powder Mill Road, Maynard, Massachusetts 01754 Tel. 617 897-8801

TABLE of CONTENTS

	<i>Page Number</i>
Balun	1
Front End/JFet	2
Front End/Mos Fet	3
FM IF	4
FM IF (AGC Amp)	5
Multiplex	6
AM IF	7
Pre-Amp	8
Switchboard (R77S and R75S)	9
Speaker Switchboard (R77S and R75S)	10
Switchboard (R74S)	11
Tone Control	12
Regulator	13
Driver (R77S)	14
Driver (R75S)	15
Driver (R74S)	16
Audio Test	17-22
FM Test	23-26
AM Test	27-29
Parts List	30-31
Chassis Layout (R74S)	32
Chassis Layout (R75S)	33
Chassis Layout (R77S)	34
Addendum	35
Dial Cord Replacement	36-37
Overall Circuit Diagram (R74S)	38-39-40
Overall Circuit Diagram (R77S and R75S)	42-43-44

BALUN ASSEMBLY 100-1348-003/004

CIRCUIT
DIAGRAM 100-1348-003

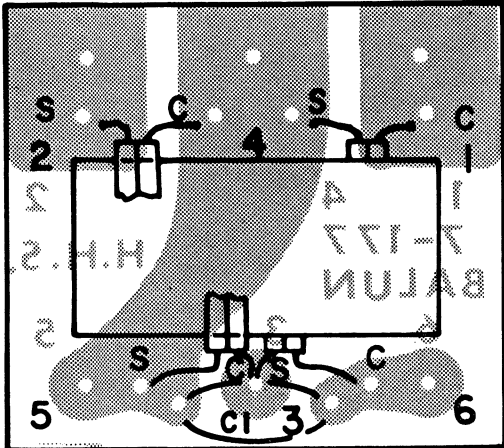

P.C.B. PART NO. 019-1007-177

CIRCUIT
DIAGRAM 100-1348-004

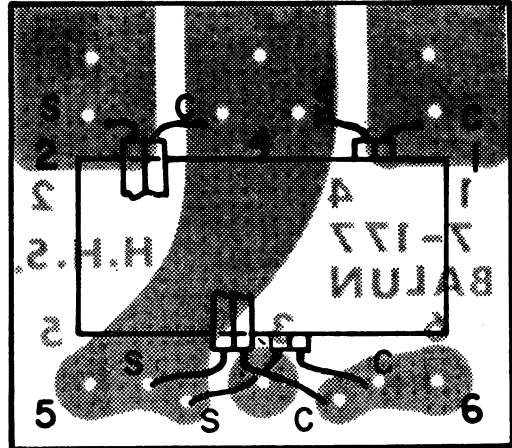

P.C.B. PART NO. 019-1107-177

NOTE: BOTH ASSEMBLIES USE BALUN COIL PART NO.
024-1143-007

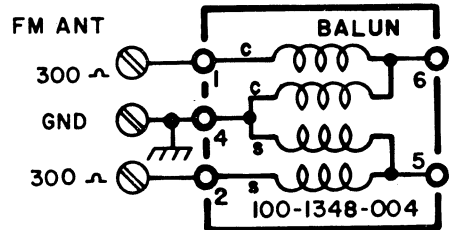
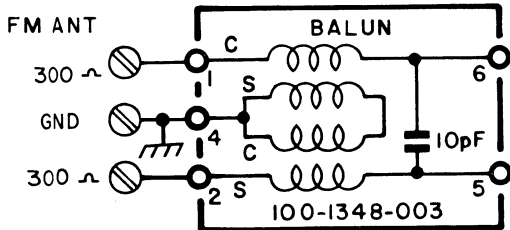

FRONT END ASSEMBLY 100-1330-029

NOTE:
1. JUMPER BETWEEN TERMINALS 10 AND 15 IS DELETED FROM 100-1330-029 ASSEMBLY.

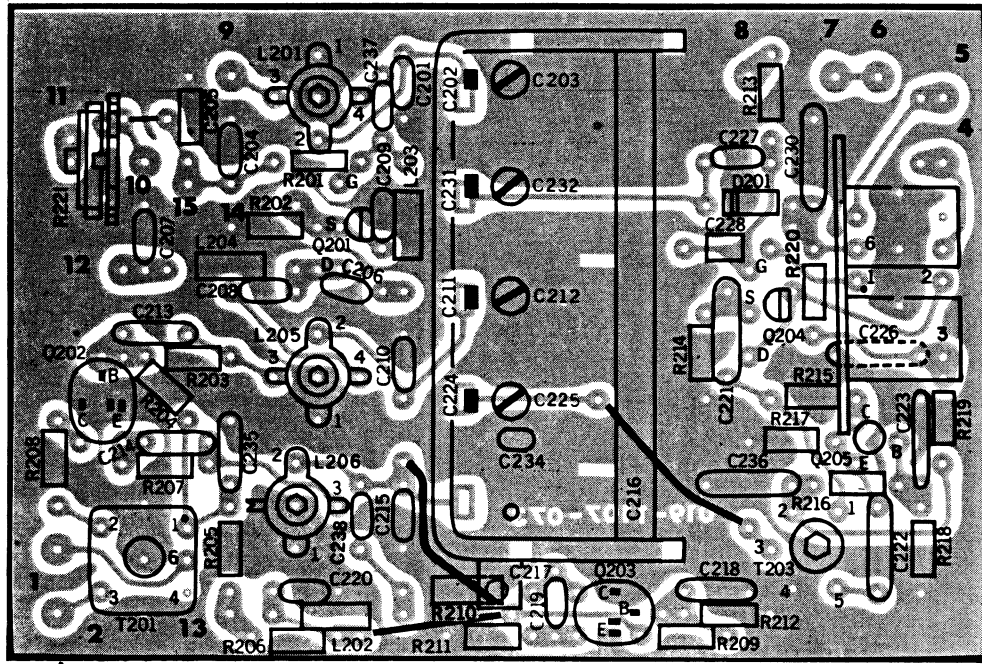

AM/FM FRONT END

019-1107-073

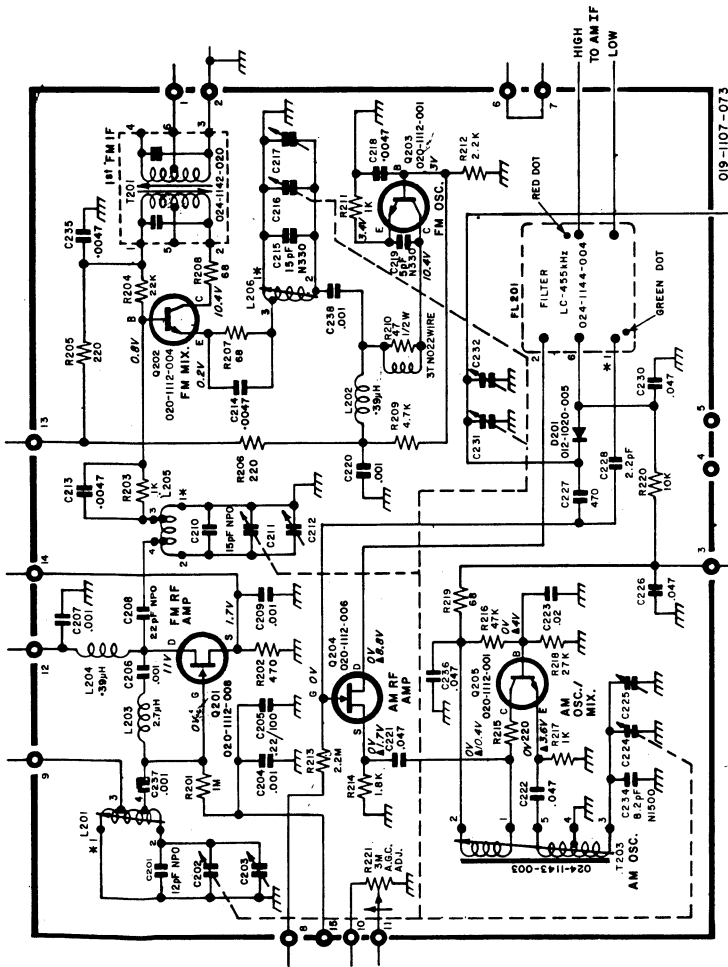

BOTTOM VIEW

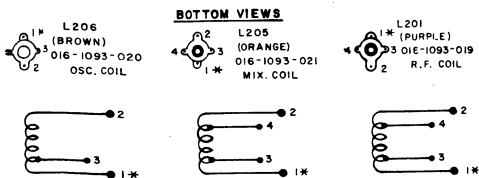

BOTTOM VIEW

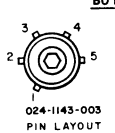

GREEN DOT STANDARD 024-1142-CAN

BOTTOM VIEW

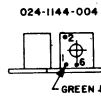

GREEN DOT

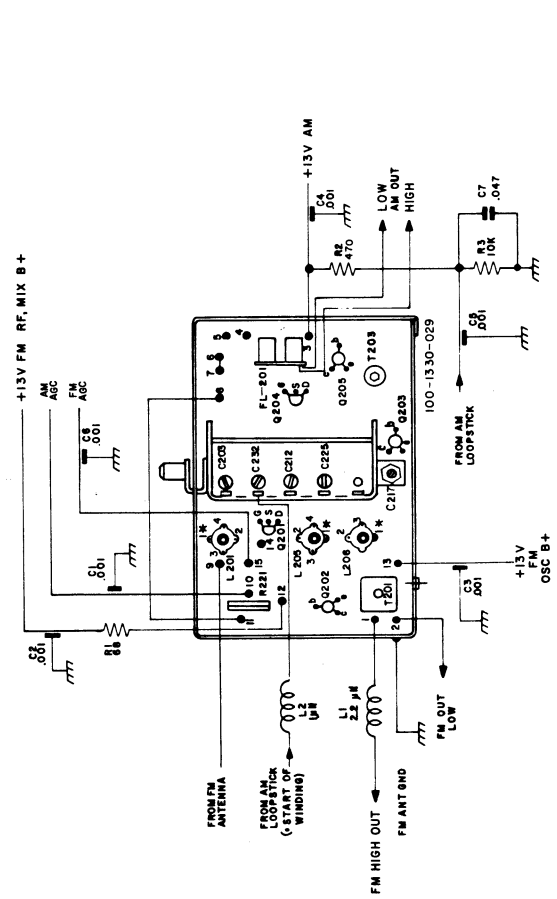

NOTES:

- UNLESS OTHERWISE SPECIFIED; RESISTANCE IN OHMS $\pm 10\%$. RESISTORS 1/4 WATT. CAPACITANCE IN MFD'S.
- * INDICATES START OF COIL WINDING.
- COMPONENTS DELETED: C229, C235.
- Δ INDICATES VOLTAGE MEASURED WITH INPUT SWITCH IN "AM" POSITION AND NO SIGNAL.
- ALL VOLTAGES $\pm 15\%$.

FRONT END ASSEMBLY 100-1330-037

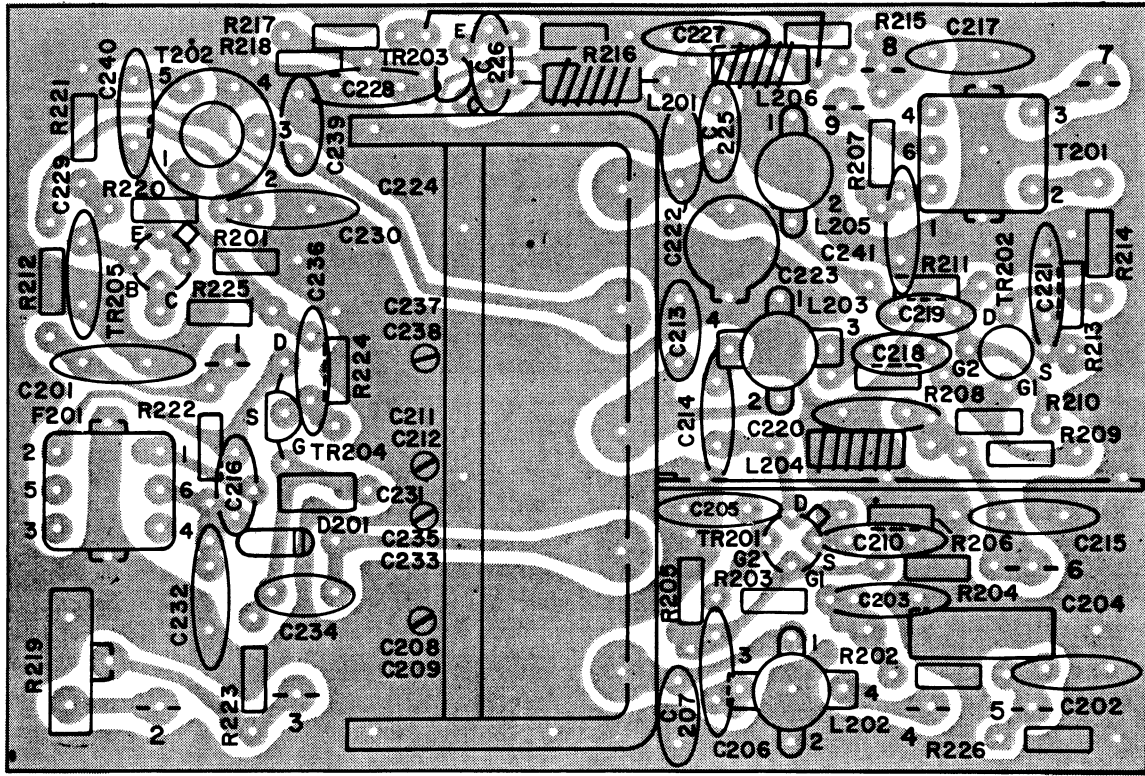

019-3107-018

NOTE:
1. C216, C217 NOT USED IN ALL UNITS.

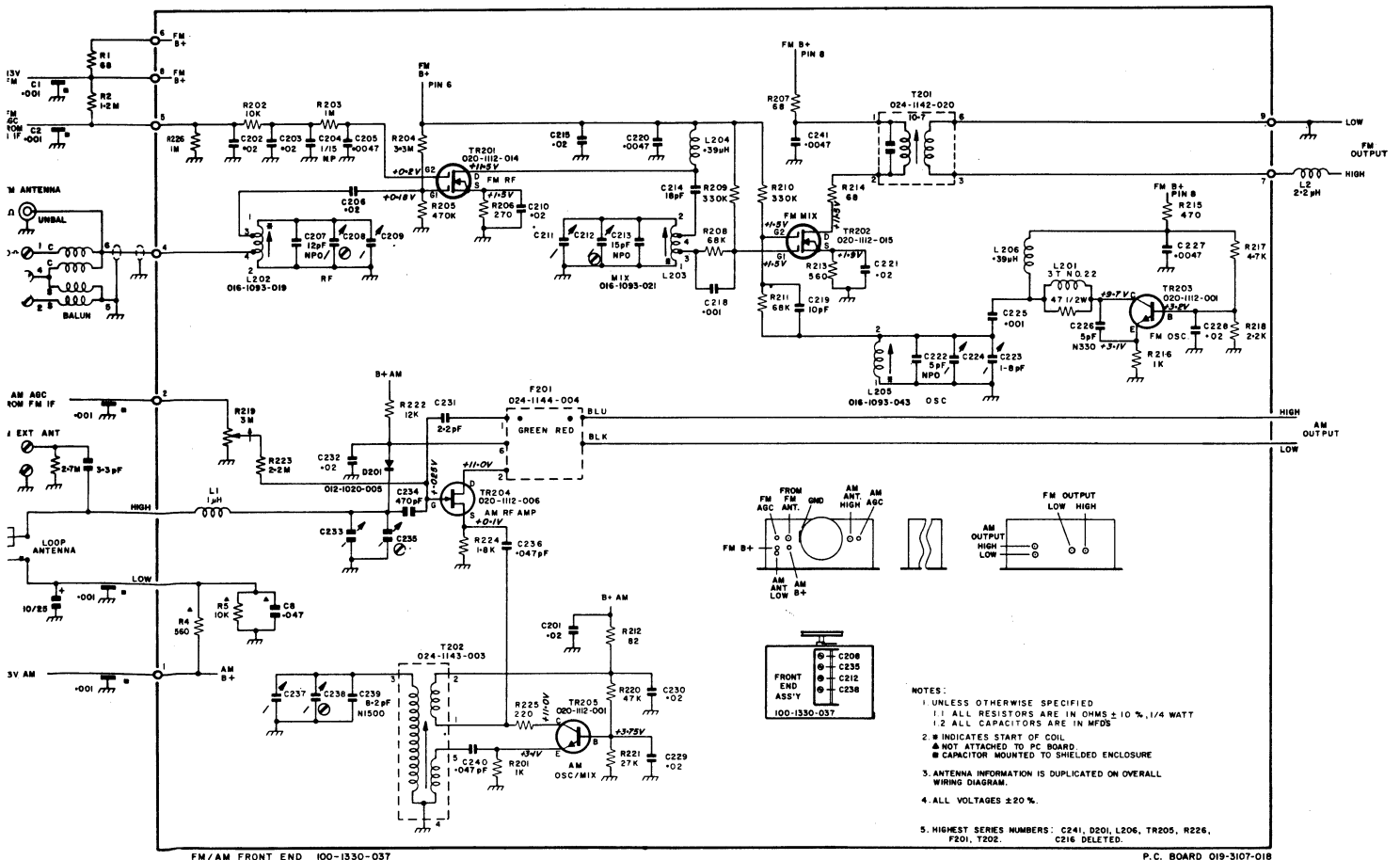

IF AMPLIFIER ASSEMBLY 100-1331-040

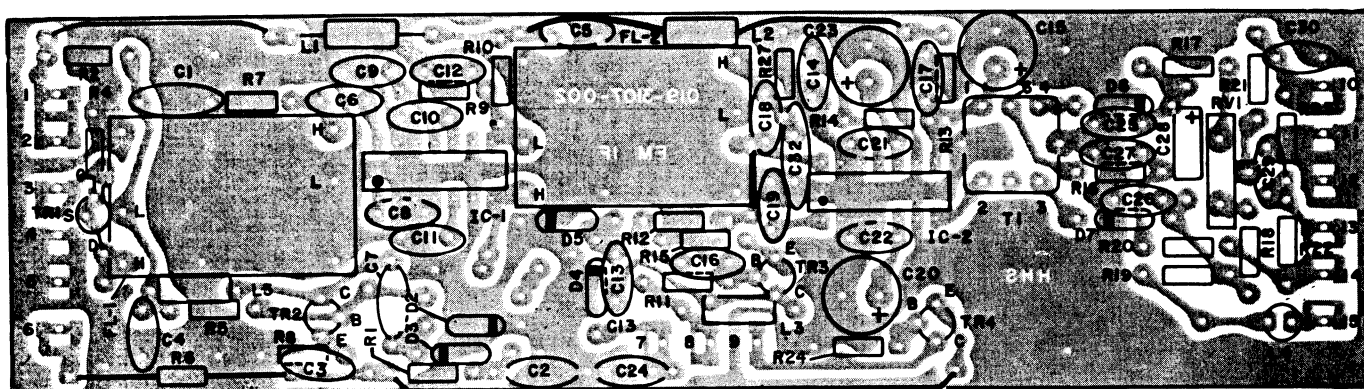

019-3107-002

- NOTE:**
1. R28 & C31. ARE TACKED TO BOTTOM OF BOARD.
 2. D2 & D3 HAVE INCORRECT CATHODE INDICATION ON PC BOARD.
 3. R7 NOT USED IN ALL UNITS.

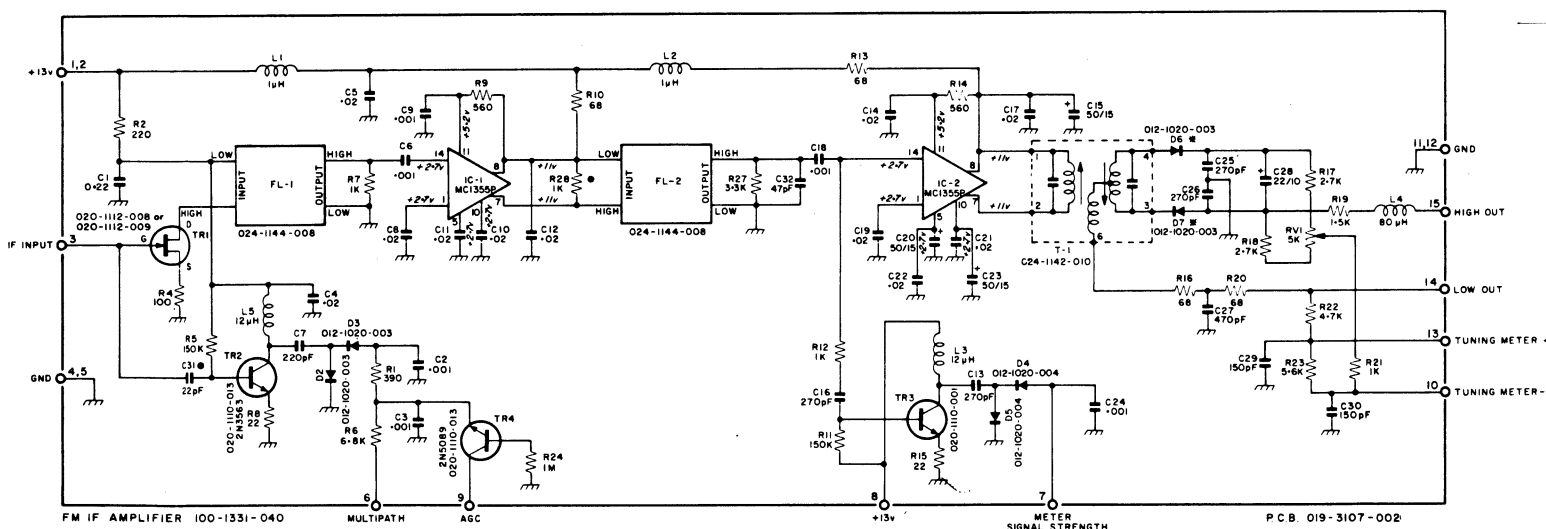

FM IF AMPLIFIER 100-1331-040

MULTIPATH

AGC

METER SIGNAL STRENGTH

P.C.B. 019-3107-002

NOTE: CORRECT P/N FOR TR3 IS 020-1112-001.

NOTES:

1. UNLESS OTHERWISE SPECIFIED:
 - A. RESISTANCE IN OHMS $\pm 5\%$, 1/4 W.
 - B. CAPACITANCE IN MFDS.
2. ALL VOLTAGES $\pm 10\%$.
3. IC1 & IC2 - ALL PINS NOT SHOWN ARE GROUNDED.
4. * R28 TACKED TO ETCHED SIDE OF BOARD & C31 ALSO.
5. * D6 & D7 ARE MATCHED POINT CONTACT GERMANIUM DIODES.
3. HIGHEST SERIES NUMBERS: R28, RV1, C32, D7, FL-2, IC-2, TR4, L5 T-1
4. COMPONENTS DELETED: R3, R25, R26, D1

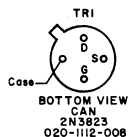
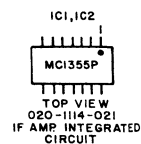

IF AMPLIFIER ASSEMBLY 100-3331-001

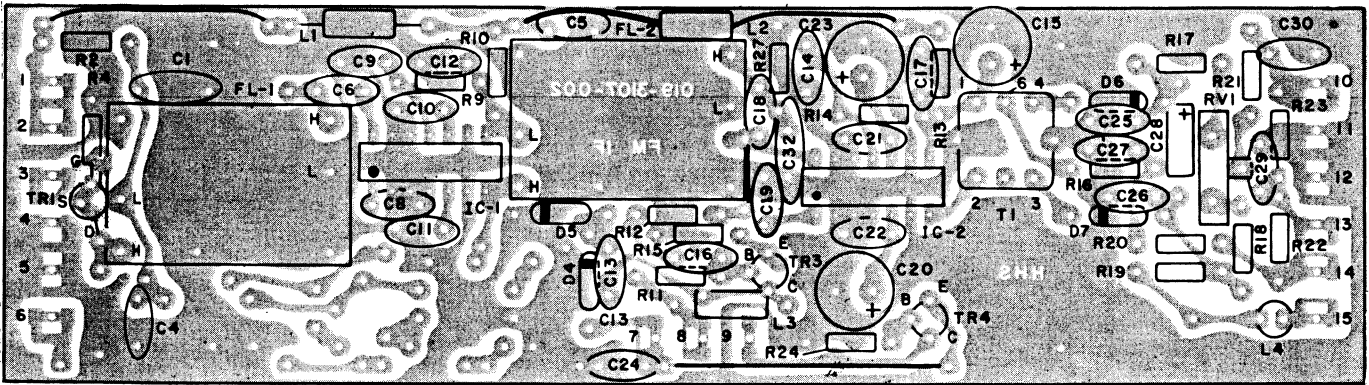

019-3107-002

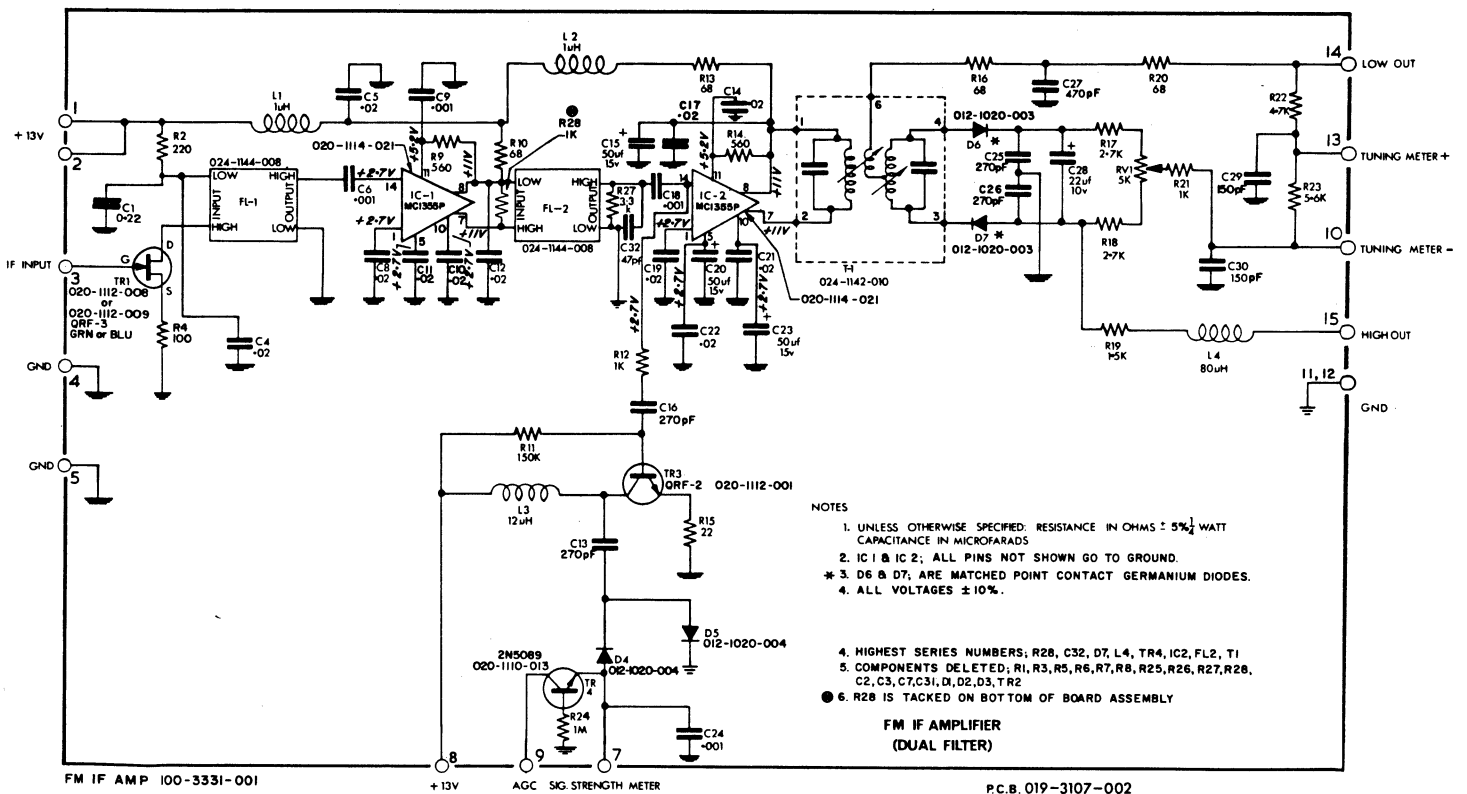

FM IF AMP 100-3331-001

P.C.B. 019-3107-002

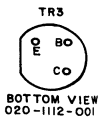

MULTIPLEX DEMODULATOR ASSEMBLY 100-3332-001

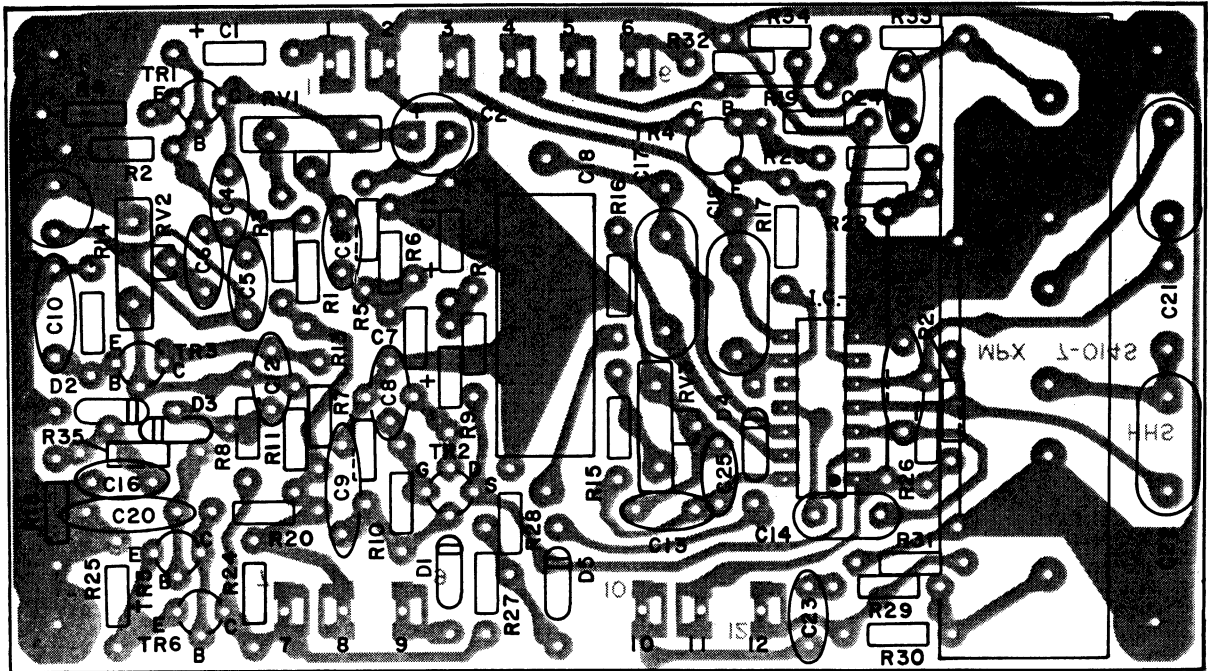

019-3107-014

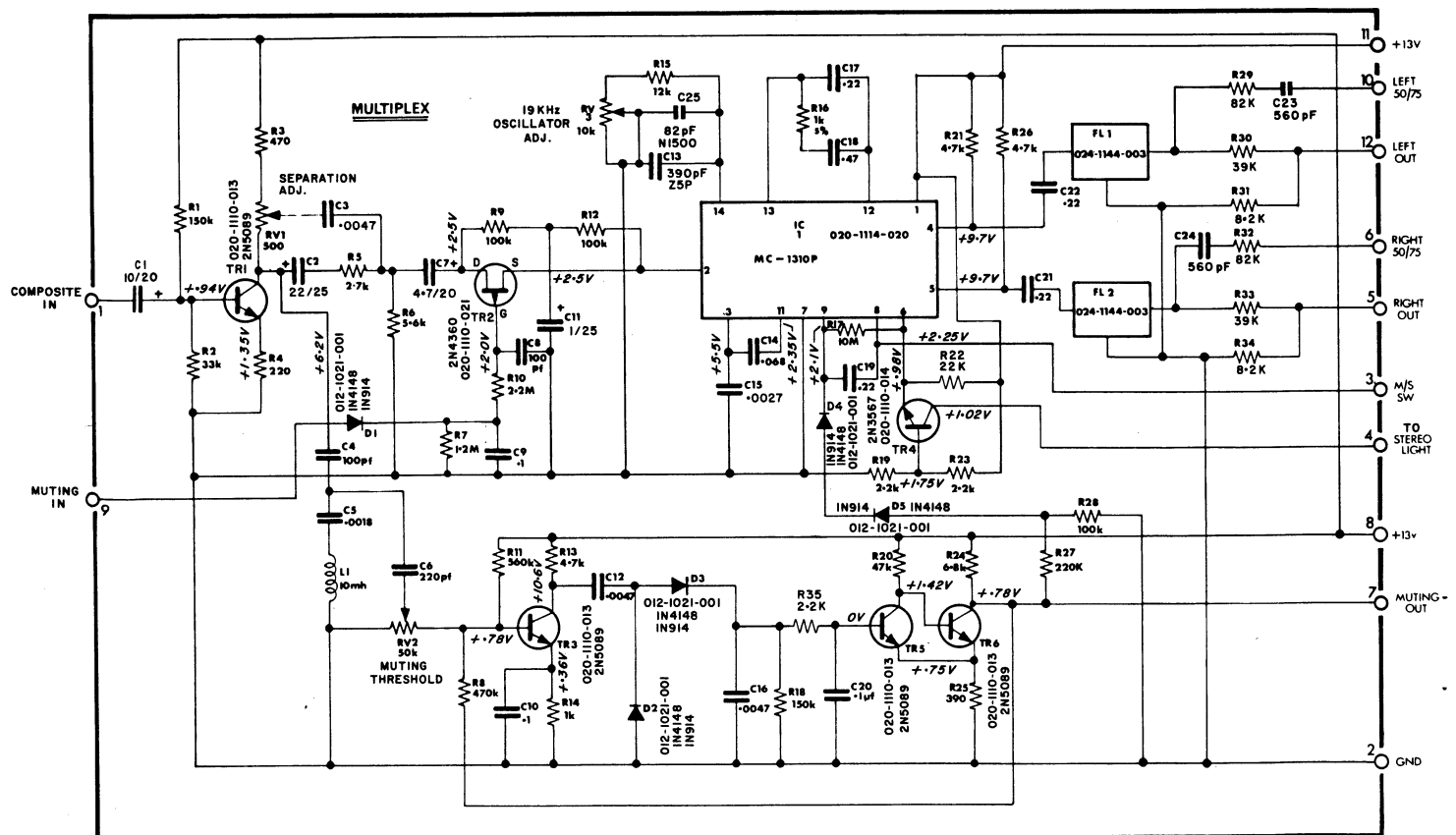

MULTIPLEX 100-3332-001

019-3107-014

- NOTES:
1. UNLESS OTHERWISE SPECIFIED: RESISTANCE IN OHMS $\pm 5\%$, 1/4 WATT AND CAPACITANCE IN MFDS.
 2. ALL VOLTAGES $\pm 10\%$, MEASURED IN STEREO MODE.
 3. MULTIPLEX ASSEMBLY WITH SINGLE MODULE FOR FL-1&FL-2, REFER TO PART NO. 024-1144-007.

4. HIGHEST SERIES NUMBERS: C25, R35, RV3, TR6, D5, IC1, FL2.
5. R35 WAS 201.

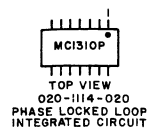
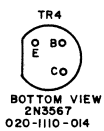
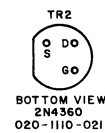

AM IF AMPLIFIER ASSEMBLY 100-1331-023

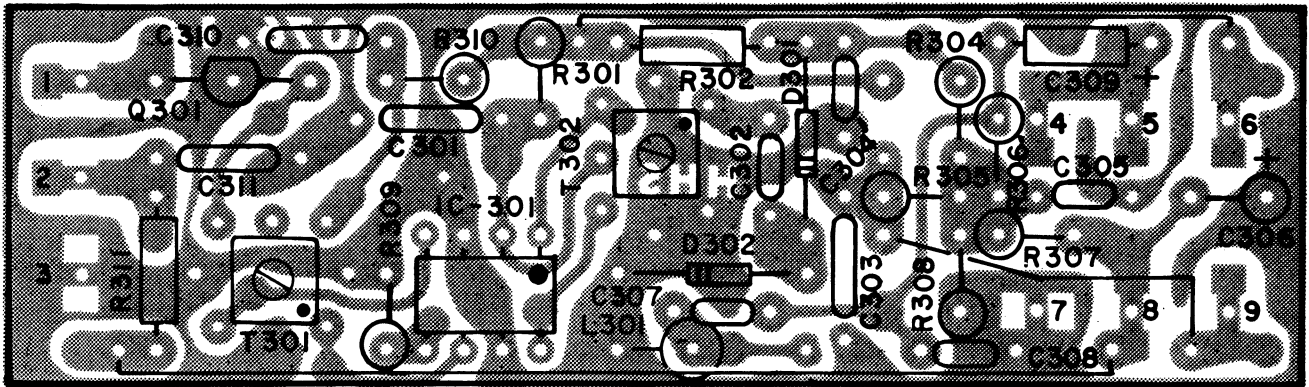

019-1107-076

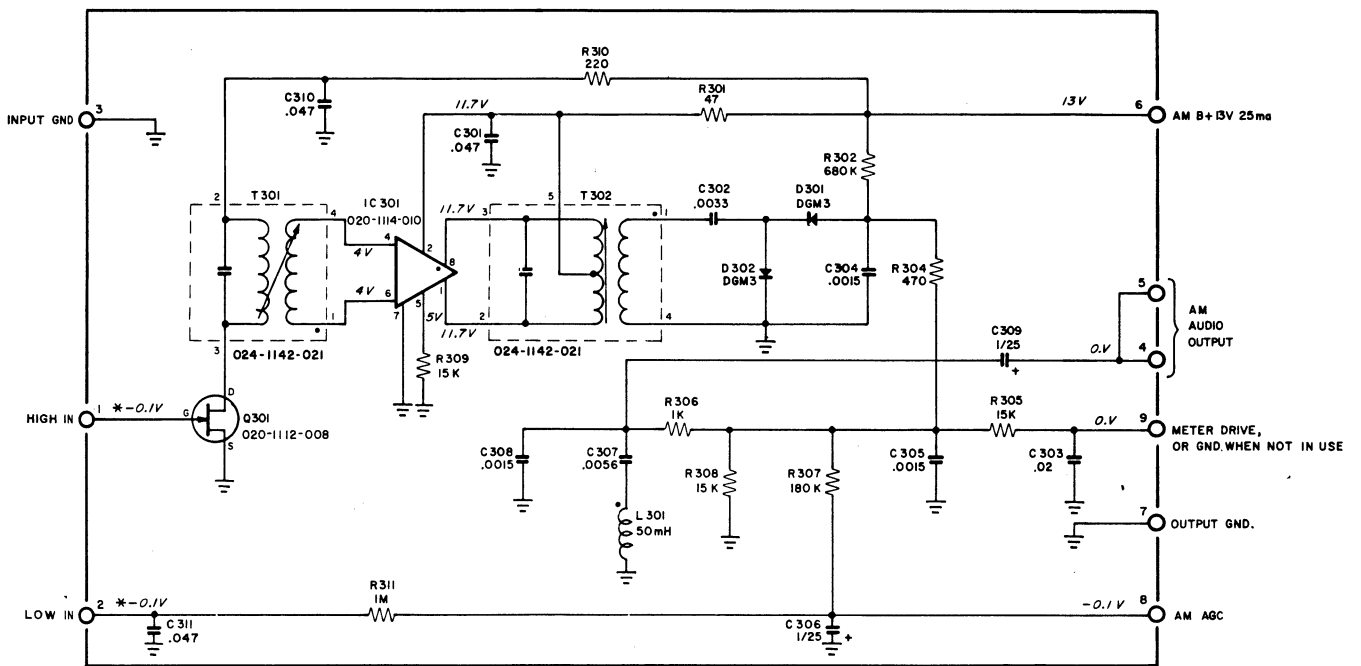

AM IF STRIP 100-1331-023

019-1107-076

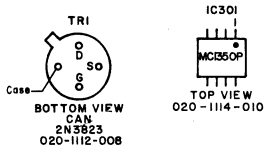

NOTES:

1. UNLESS OTHERWISE SPECIFIED; RESISTANCE IN OHMS $\pm 10\%$ 1/4 WATT, AND CAPACITANCE IN MFD'S
2. IC 301 IS 020-1114-010, T 301 AND T 302 ARE 016-1093-024, Q 301 IS 020-1112-008
3. HIGHEST SERIES NUMBERS, C 311, R 311, L 301, IC 301, T 302, Q 301, D 302.
4. GREEN DOT ON TOP OF TRANSFORMER OR COIL CAN INDICATES PIN NO 1.
5. DOT ON TOP OR TIP ON SIDE OF IC INDICATES PIN NO 8.
6. * HIGH INPUT IMPEDANCE METER ONLY (10 M Ω OR HIGHER).
7. DOT ON CHOKE INDICATES START OF WINDING.
8. COMPONENTS DELETED; R 303

PREAMPLIFIER ASSEMBLY 100-3333-001

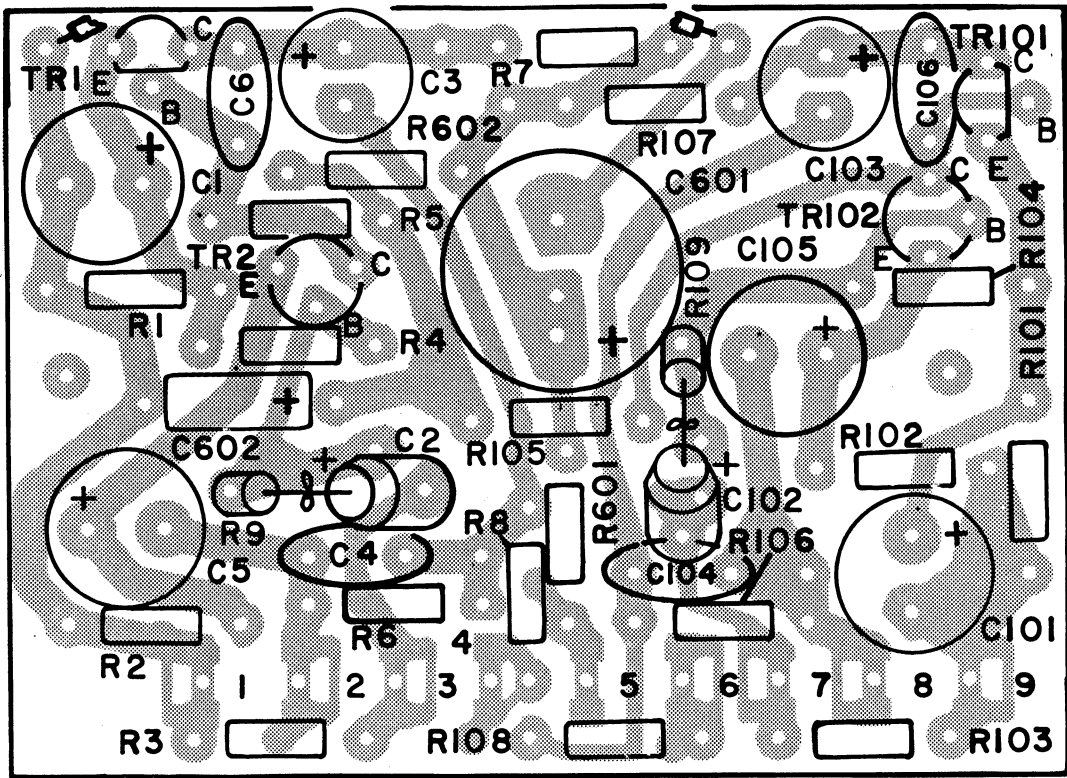

019-3107-017

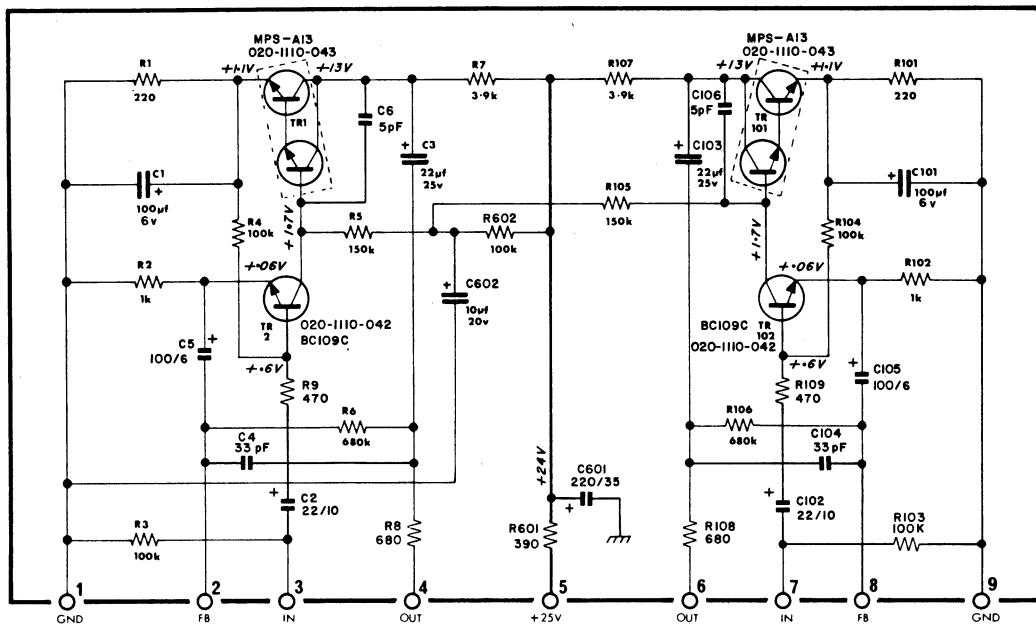

PREAMP 100-3333-001

019-3107-017

NOTES:

1. UNLESS OTHERWISE SPECIFIED: RESISTANCE IN OHMS $\pm 10\%$, 1/4 WATT AND CAPACITANCE IN MFD'S.
2. ALL VOLTAGES $\pm 10\%$.
3. HIGHEST SERIES NUMBERS: C6, C106, R9, R109, TR2, TR102, R602, C602.

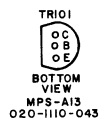

SWITCHBOARD ASSEMBLY 100-1352-017

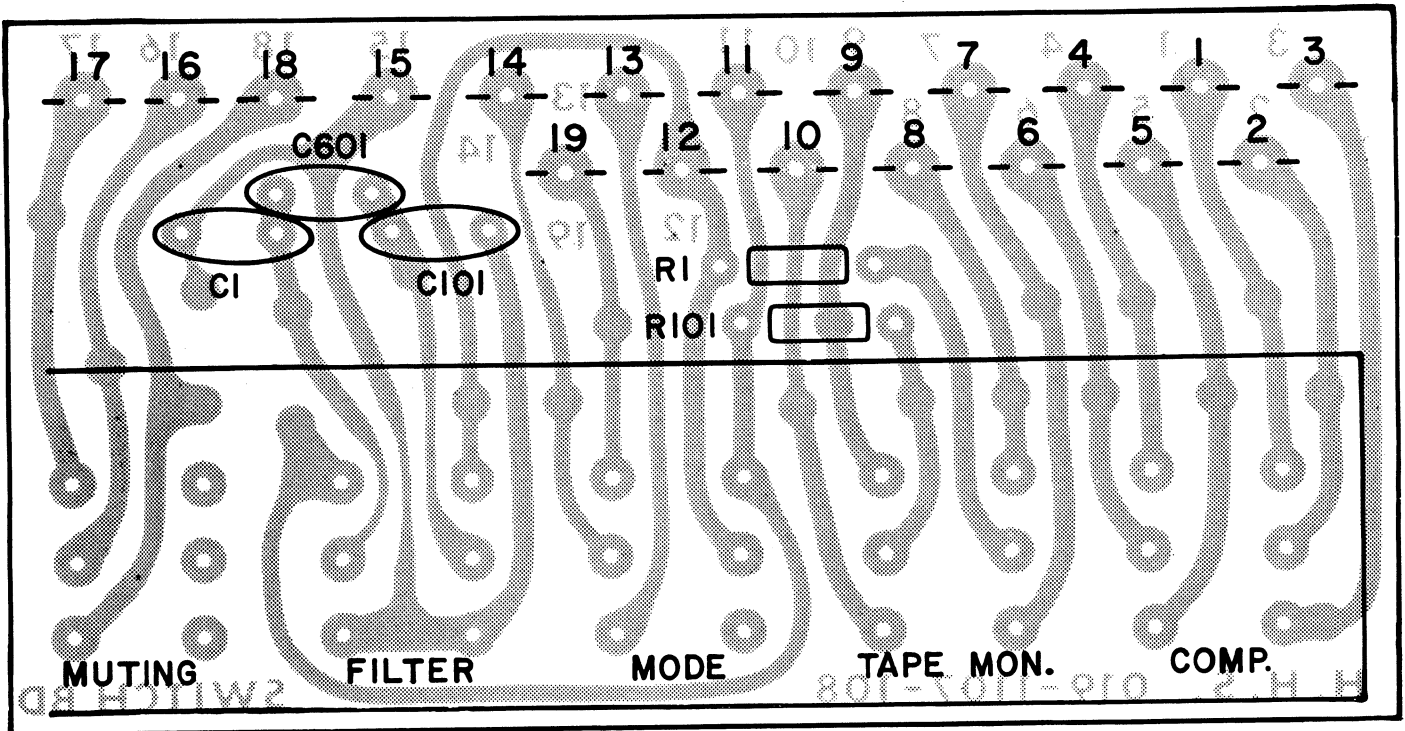

019-1107-108

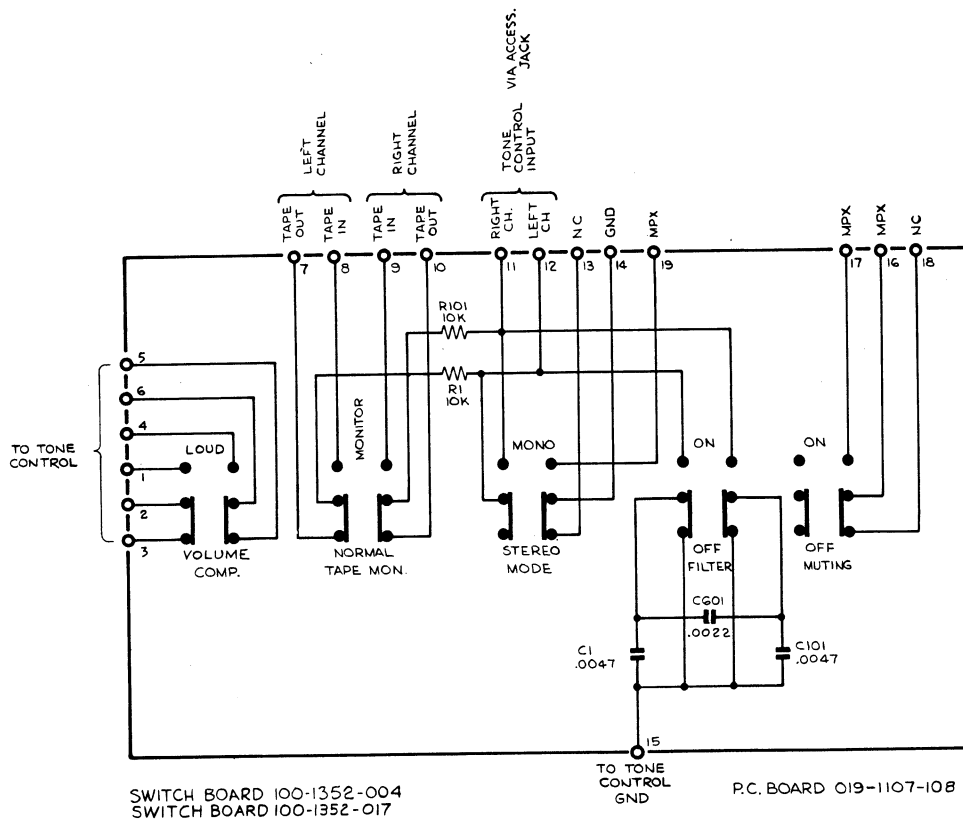

- NOTES:
1. UNLESS OTHERWISE SPECIFIED: RESISTANCE IN OHMS $\pm 10\%$ $\frac{1}{4}$ WATT, CAPACITANCE IN MFD'S.
 2. HIGHEST SERIES NO'S ARE: R1, R101, C1, C101 & C601
 3. AC POWER SWITCH IS MECHANICALLY CONNECTED TO OTHER SWITCHES ON BOARD.

SPEAKER SWITCHBOARD ASSEMBLY 100-1352-018

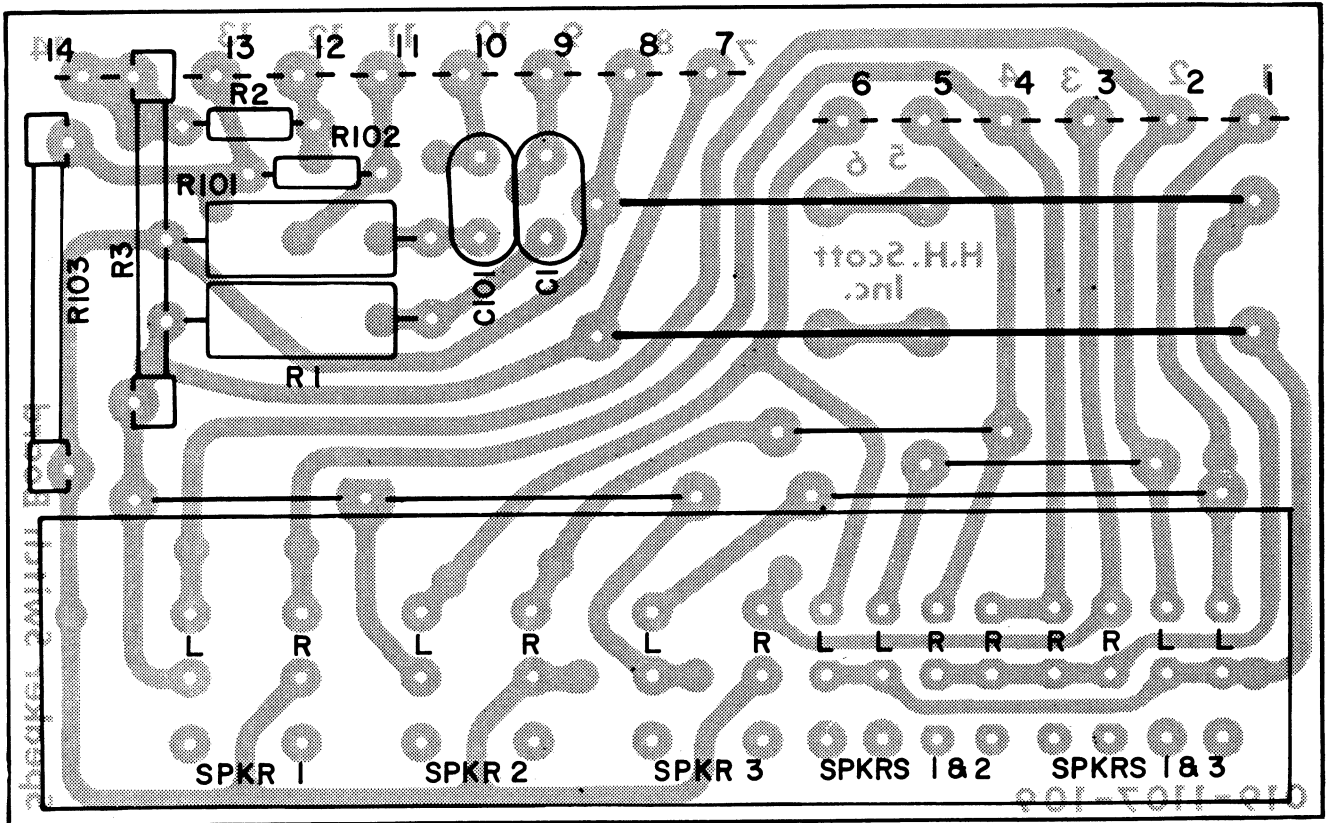

019-1107-109

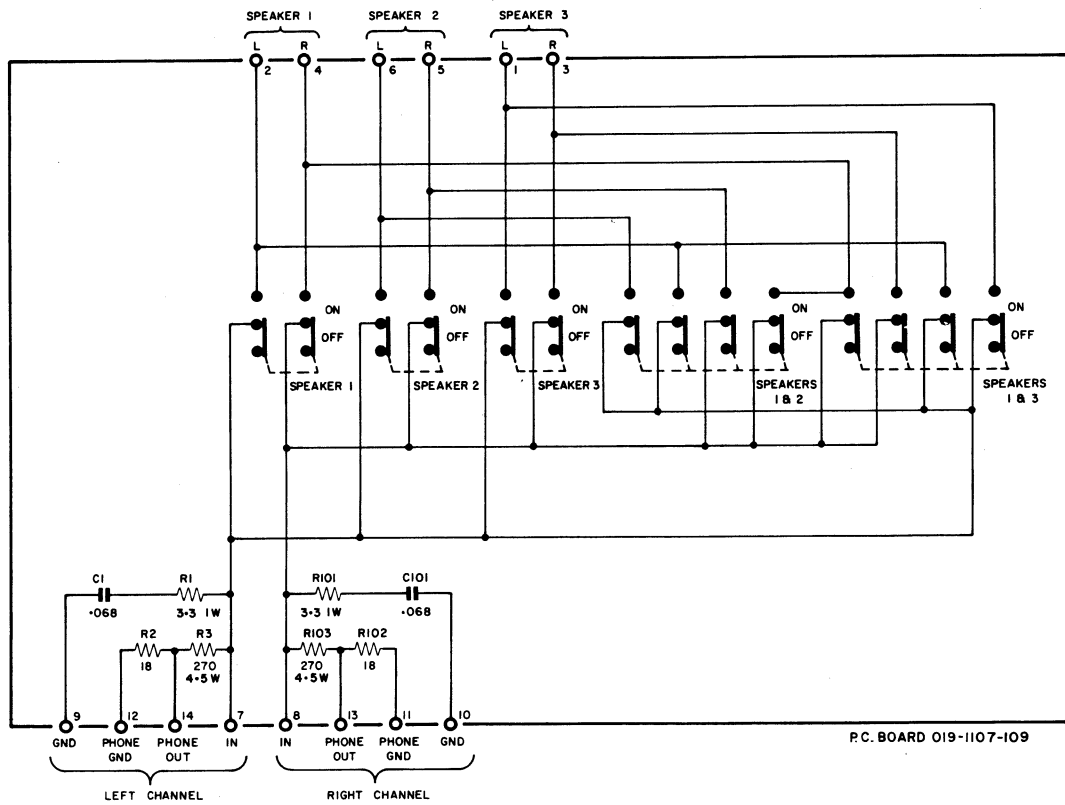

- NOTES:
1. UNLESS OTHERWISE SPECIFIED; RESISTANCE IN OHMS $\pm 10\%$ 1/4 WATT, CAPACITANCE IN MFD'S.
 2. HIGHEST SERIES NO'S ARE; R5, R105, C1, C101
 3. COMPONENTS DELETED; R4, R5, R104, R105

SWITCH ASSEMBLY 100-1352-016

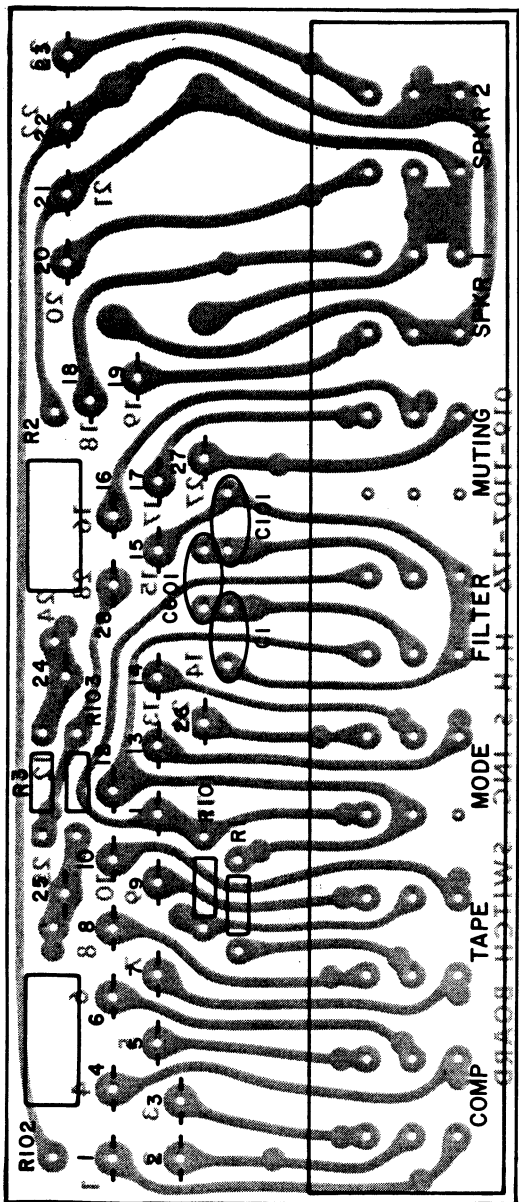

019-1107-176

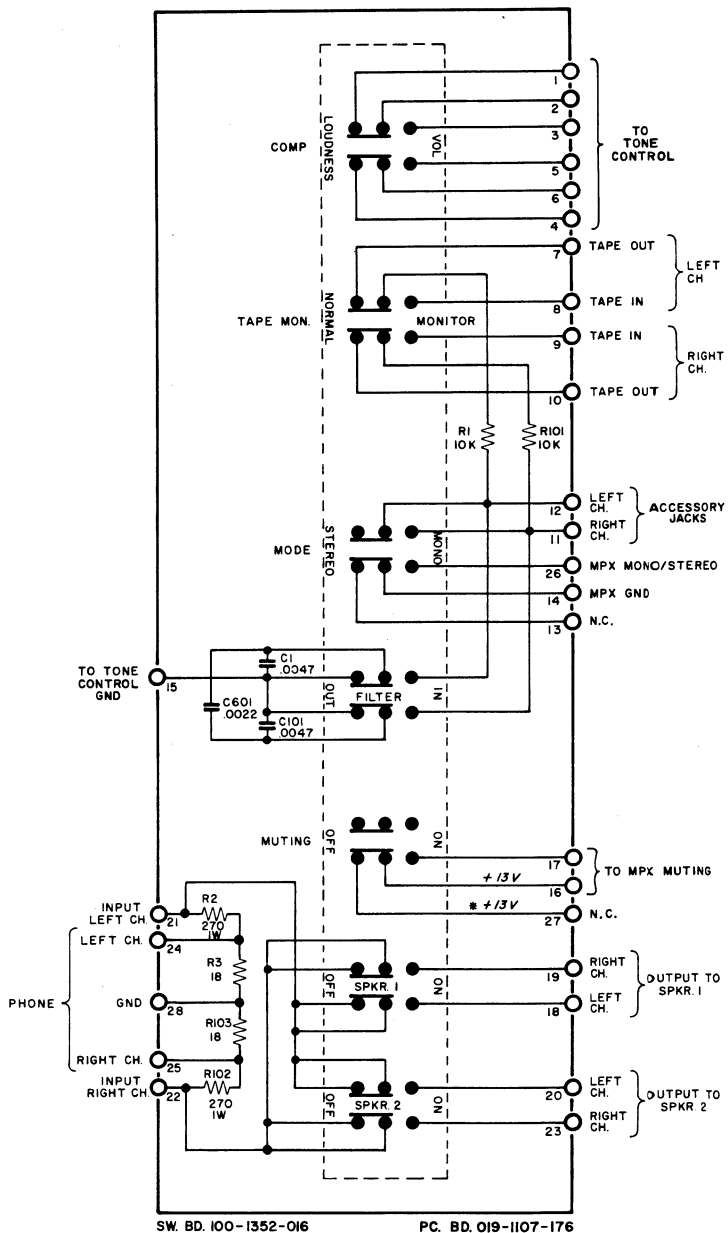

SW. BD. 100-1352-016

PC. BD. 019-1107-176

- NOTES:
1. UNLESS OTHERWISE SPECIFIED:
 - A. RESISTANCE IN OHMS, ±10% 1/4 WATT
 - B. CAPACITANCE IN MFD'S.
 2. * WHEN MUTING IS OFF
 3. ALL VOLTAGES ±10%

TONE CONTROL ASSEMBLY 100-1334-018/019

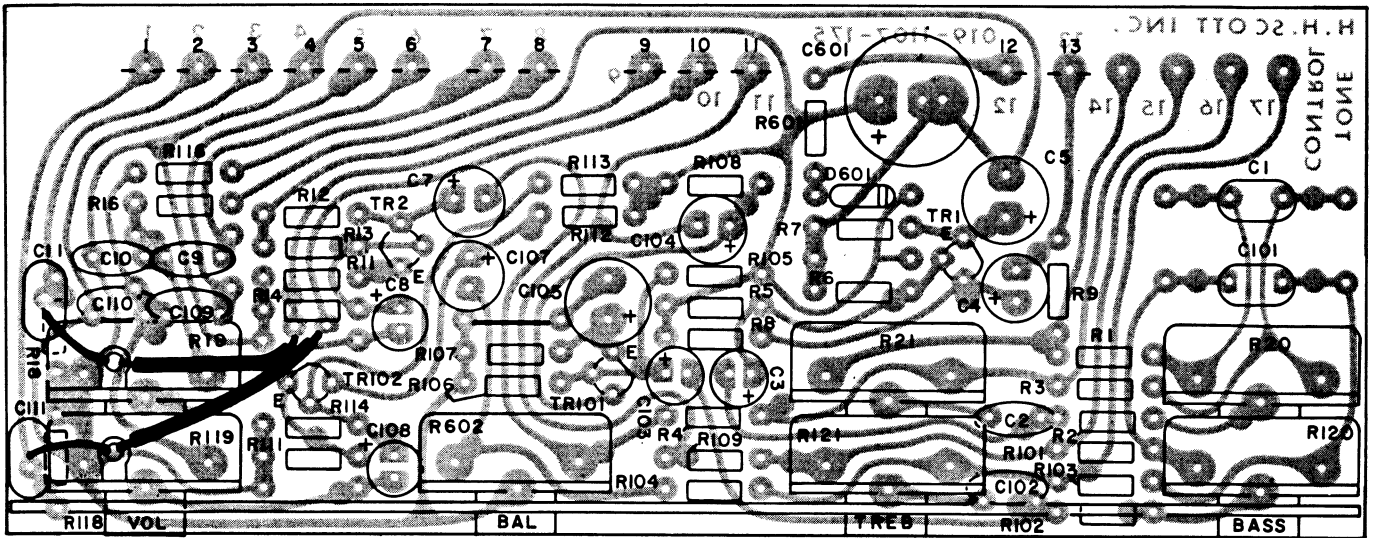

019-1107-175

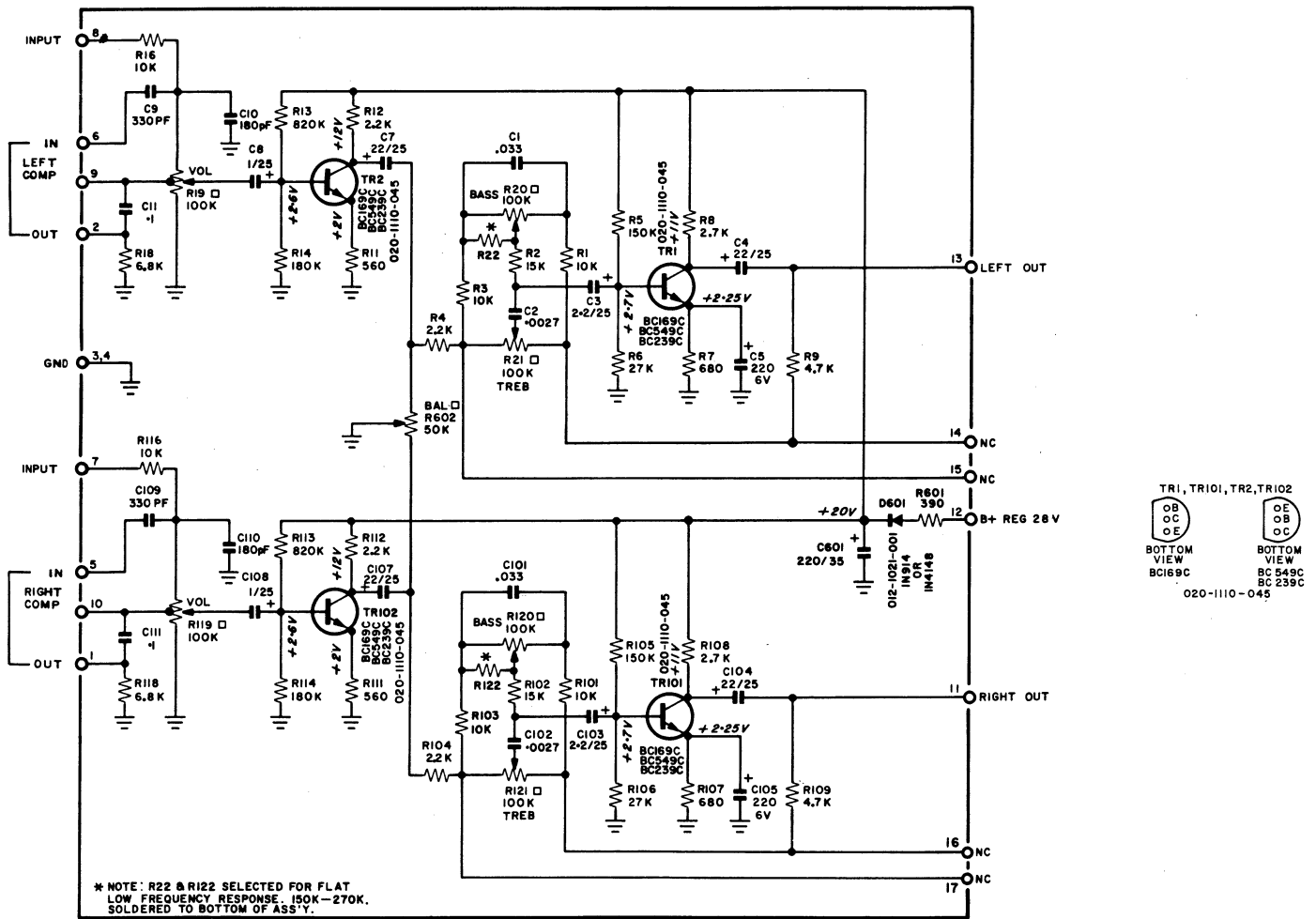

* NOTE: R22 & R122 SELECTED FOR FLAT LOW FREQUENCY RESPONSE. 150K-270K. SOLDERED TO BOTTOM OF ASS'Y.

TONE CONTROL 100-1334-018 - 100-1334-019

P.C. BOARD 019-1107-175

NOTES:

1. UNLESS OTHERWISE SPECIFIED:
A. RESISTANCE IN OHMS $\pm 5\% 1/4W$.
B. CAPACITANCE IN MFD'S.
2. ALL VOLTAGES $\pm 10\%$.
3. HIGHEST SERIES NUMBERS: C11, C111, C601, D601, R22, R122, R602, Q2, Q102.

□ ASSEMBLIES ARE IDENTICAL WITH THE EXCEPTION OF POTENTIOMETERS WHICH ARE:
100-1334-018 100-1334-019

- | | |
|------------------------------|------------------------------|
| □ VOLUME - 021-1125-120 100K | □ VOLUME - 021-1125-120 100K |
| □ BALANCE - 021-1125-119 50K | □ BALANCE - 021-1125-122 50K |
| □ TONE - 021-1125-121 100K | □ TONE - 021-1125-125 100K |

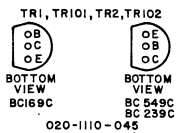

REGULATOR ASSEMBLY 100-3340-001

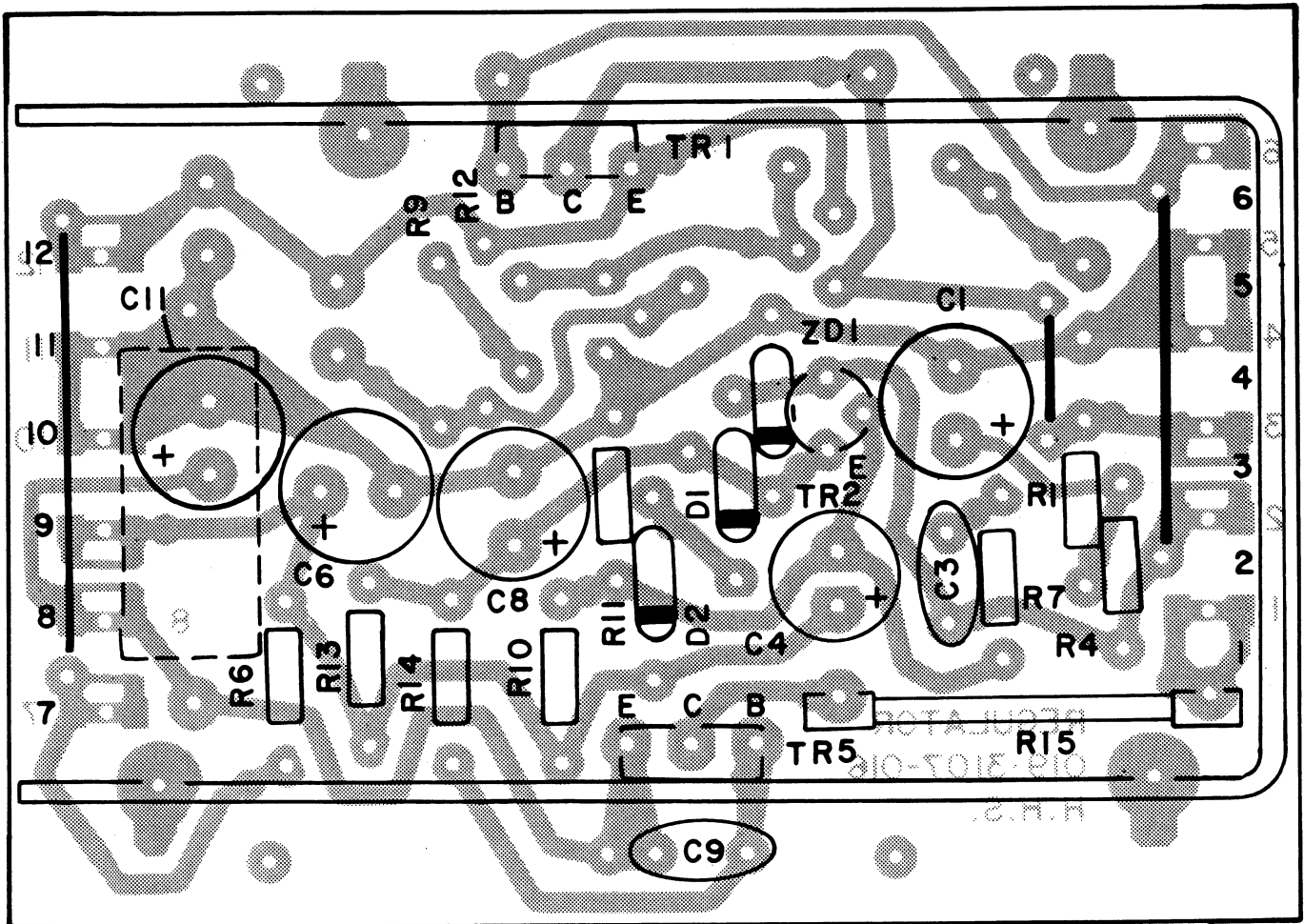

019-3107-016

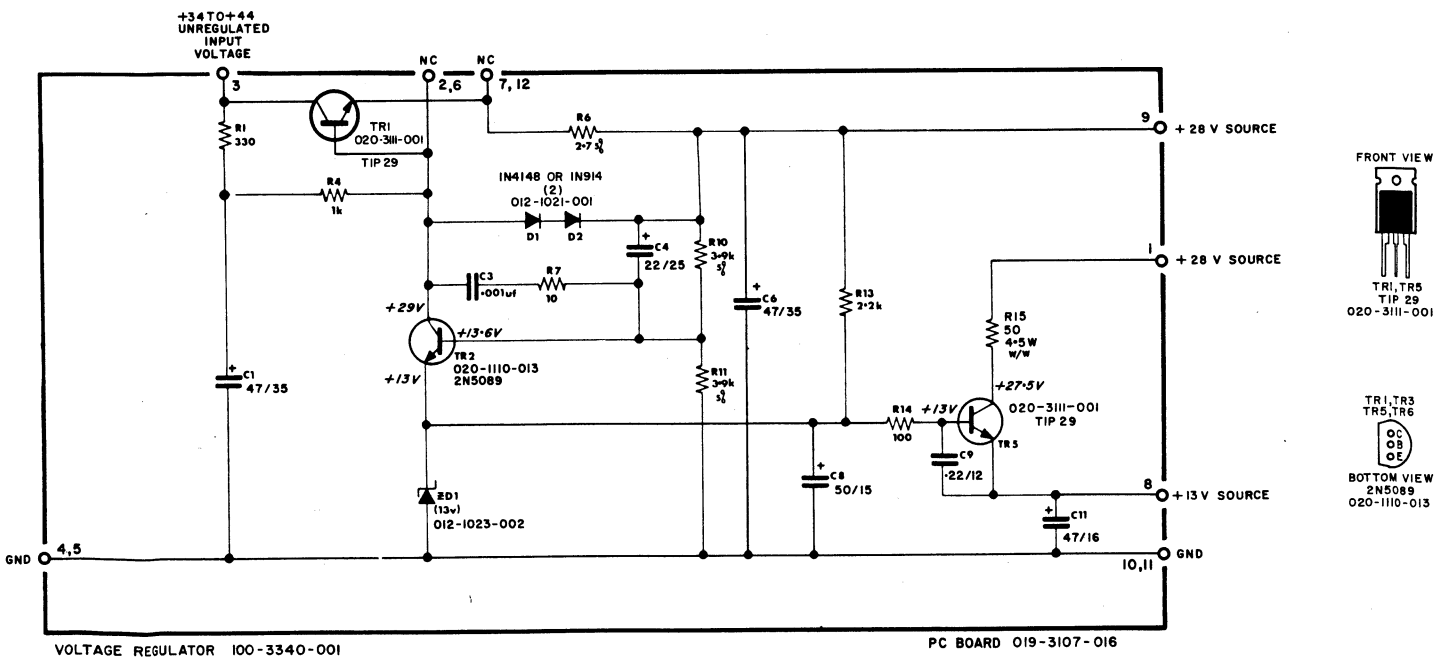

- NOTES:
1. UNLESS OTHERWISE SPECIFIED: RESISTANCE IN OHMS $\pm 10\%$, 1/4 WATT AND CAPACITANCE IN MFD'S.
 2. ALL VOLTAGES $\pm 10\%$.
 3. HIGHEST SERIES NUMBERS: C11, R15, TR5, ZD1, D2.
 4. COMPONENTS DELETED: C2, C5, C7, C10, R2, R3, R5, R8, R9, R12, TR3, TR4.
 5. TERMINALS 1&9 EXTERNALLY CONNECTED WITH JUMPER.

DRIVER ASSEMBLY 100-3335-001

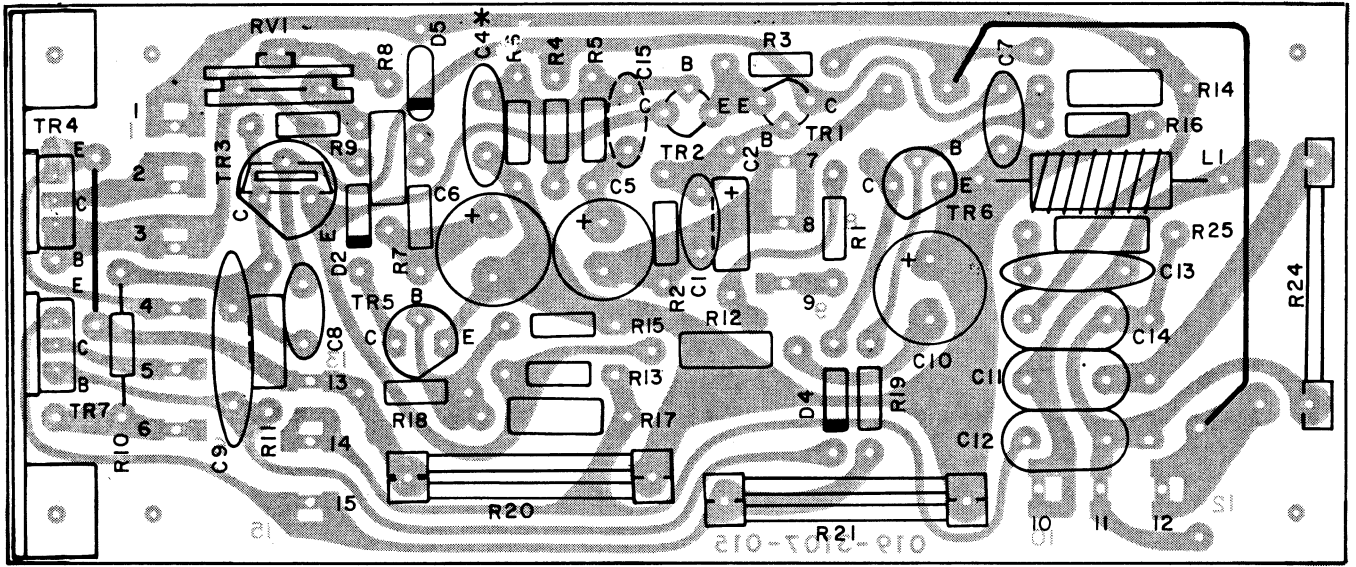

NOTE:
1. *C4 ELIMINATED ON ASSEMBLY 100-3335-004

019-3107-015

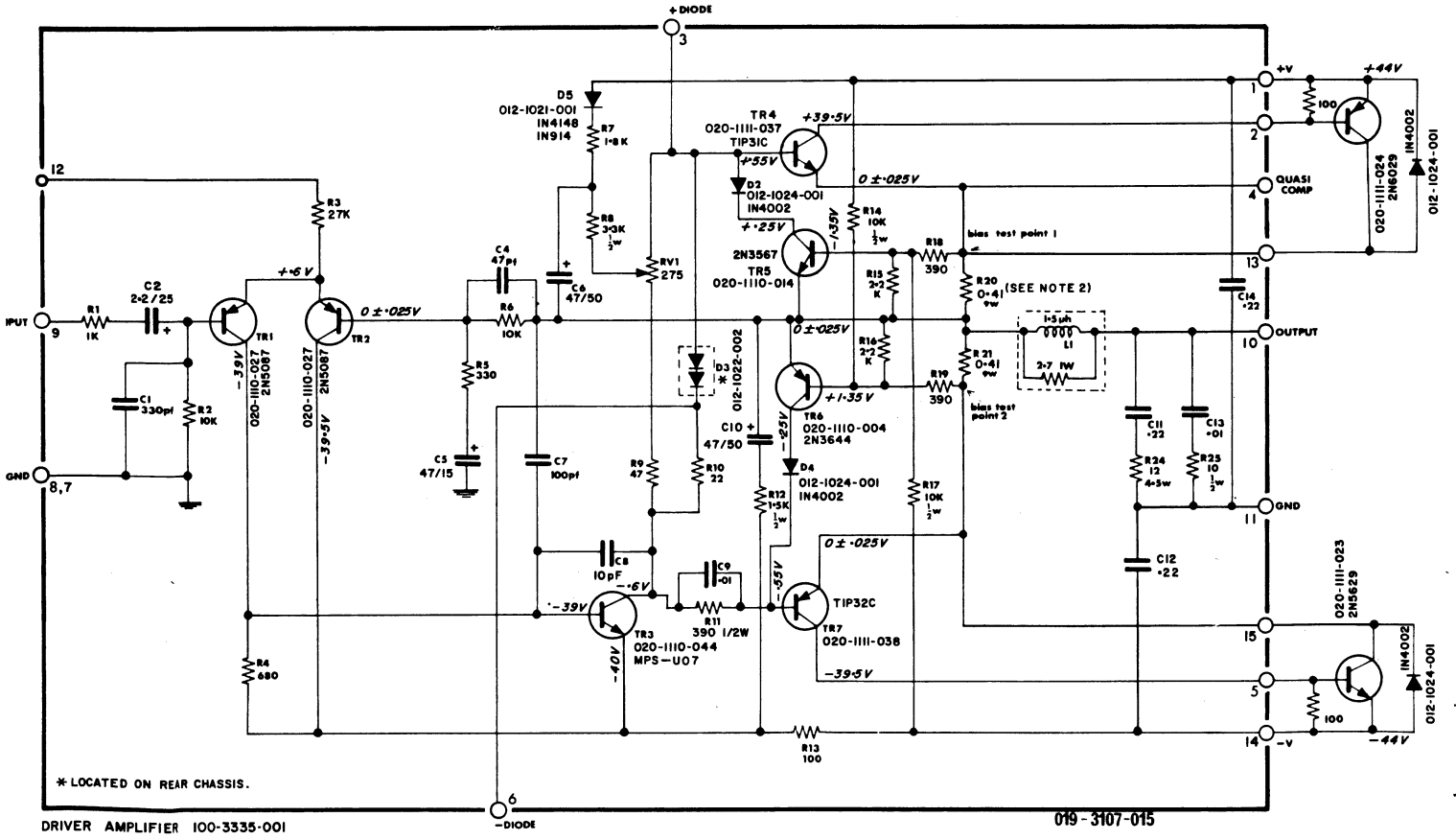

DRIVER AMPLIFIER 100-3335-001

019-3107-015

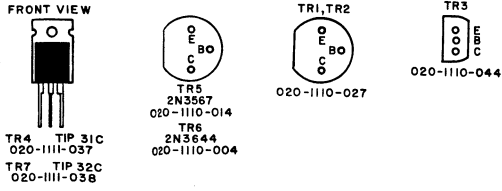

- NOTES:
- UNLESS OTHERWISE SPECIFIED: ALL RESISTANCE IN OHMS $\pm 10\%$, 1/4 WATT AND CAPACITANCE IN MFD'S.
 - R20 AND R21 MAY CONSIST OF PARALLEL PAIRS, TWO .82 IN PARALLEL.
 - ALL VOLTAGES $\pm 10\%$.
 - HIGHEST SERIES NUMBERS: C14, R25, D5, TR7, RV1
 - COMPONENTS DELETED: R22, R23, C3, D3, D1
 - OUTPUT TRANSISTOR CIRCUIT INFORMATION IS DUPLICATED ON OVERALL WIRING DIAGRAM.

DRIVER ASSEMBLY 100-3335-002

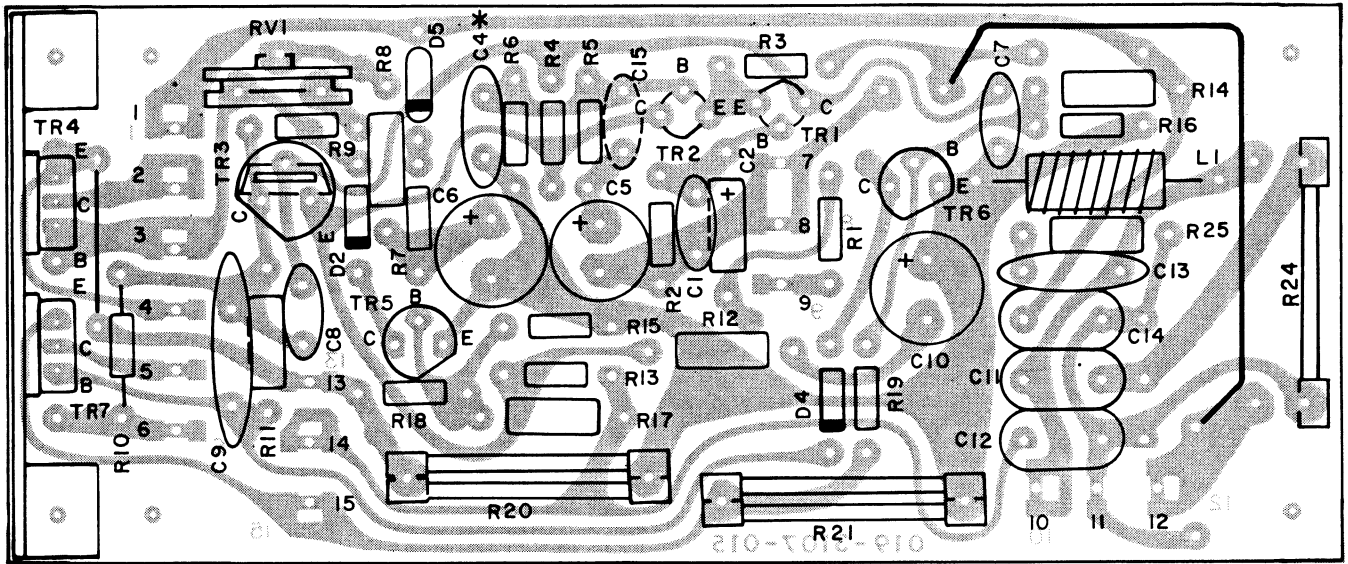

NOTE:
1. *C4 ELIMINATED ON ASSEMBLY 100-3335-004

019-3107-015

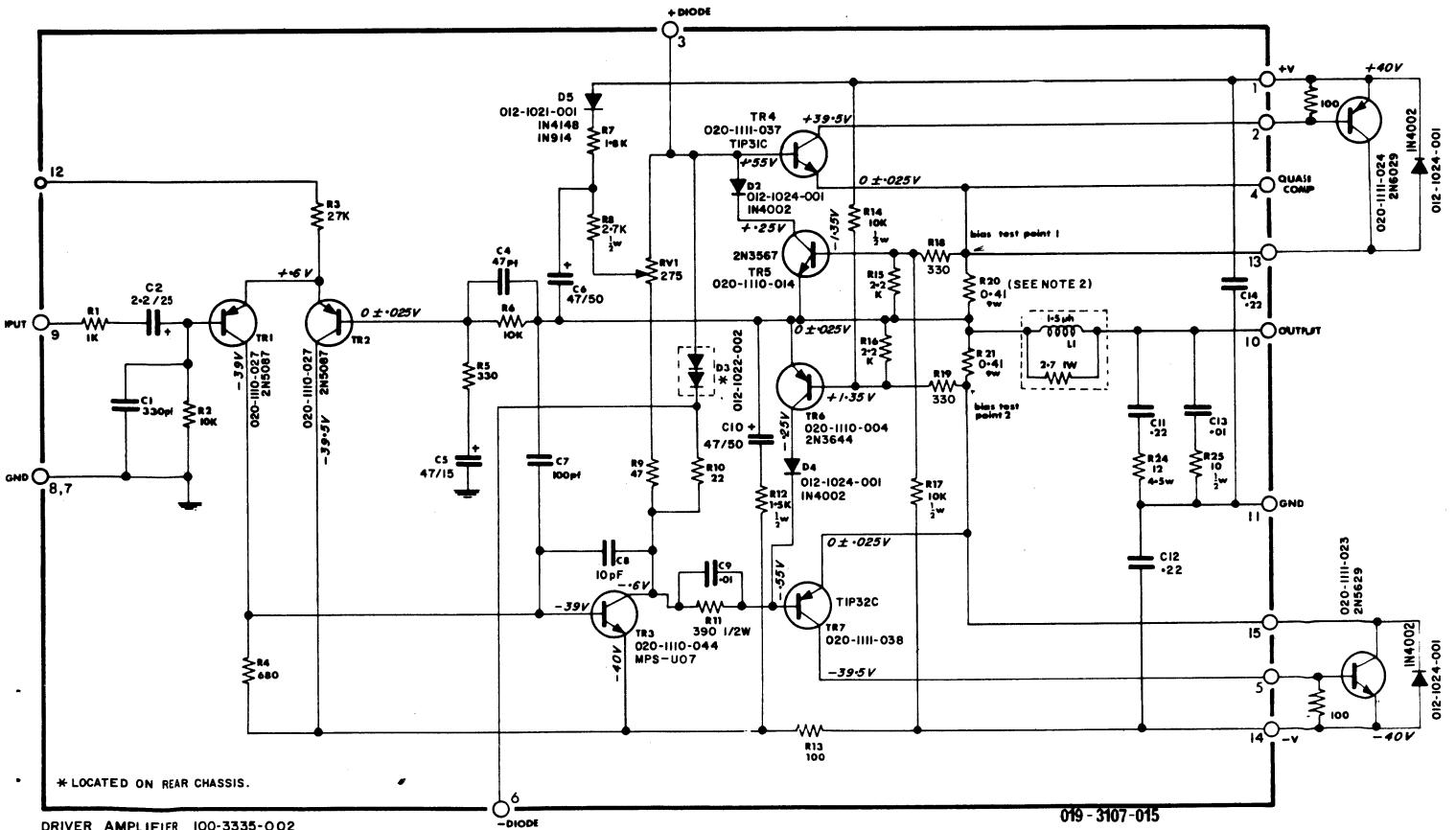

* LOCATED ON REAR CHASSIS.

DRIVER AMPLIFIER 100-3335-002

019-3107-015

- NOTES:
1. UNLESS OTHERWISE SPECIFIED: ALL RESISTANCE IN OHMS $\pm 10\%$, 1/4 WATT AND CAPACITANCE IN MFD'S.
 2. R20 AND R21 MAY CONSIST OF PARALLEL PAIRS, TWO $\cdot 82$ IN PARALLEL.
 3. ALL VOLTAGES $\pm 10\%$.
 4. HIGHEST SERIES NUMBERS: C14, R25, D5, TR7, RV1
 5. COMPONENTS DELETED: R22, R23, C3, D3, D1
 6. OUTPUT TRANSISTOR CIRCUIT INFORMATION IS DUPLICATED ON OVERALL WIRING DIAGRAM.

DRIVER ASSEMBLY 100-3335-004

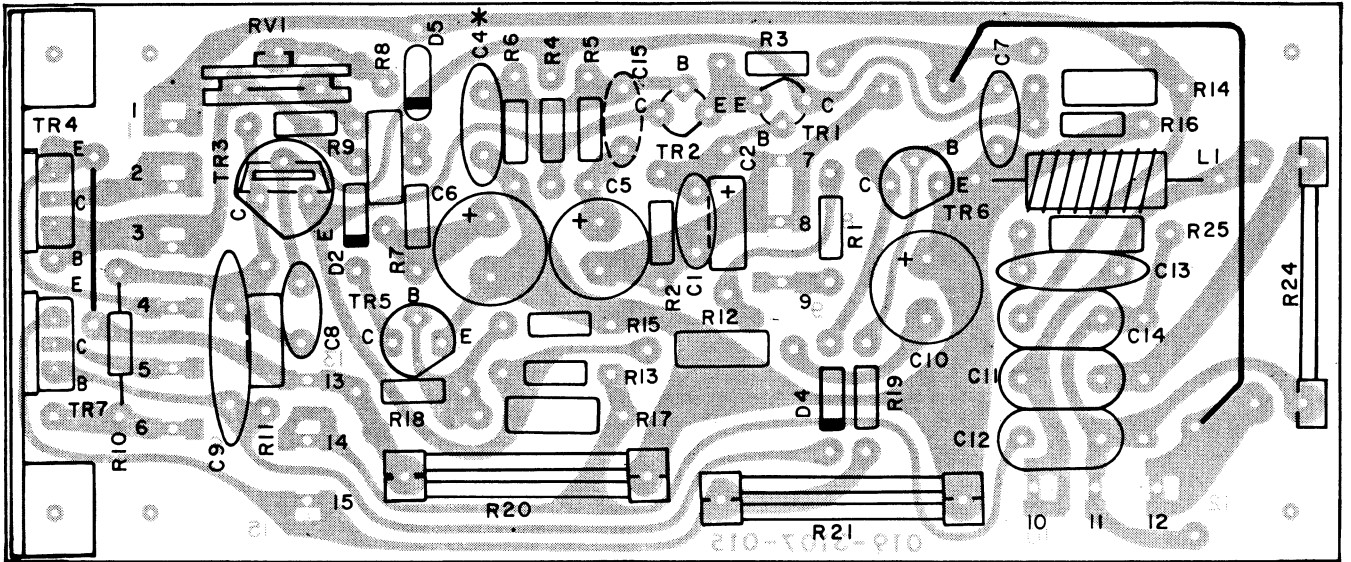

NOTE:
1. *C4 ELIMINATED ON ASSEMBLY 100-3335-004

019-3107-015

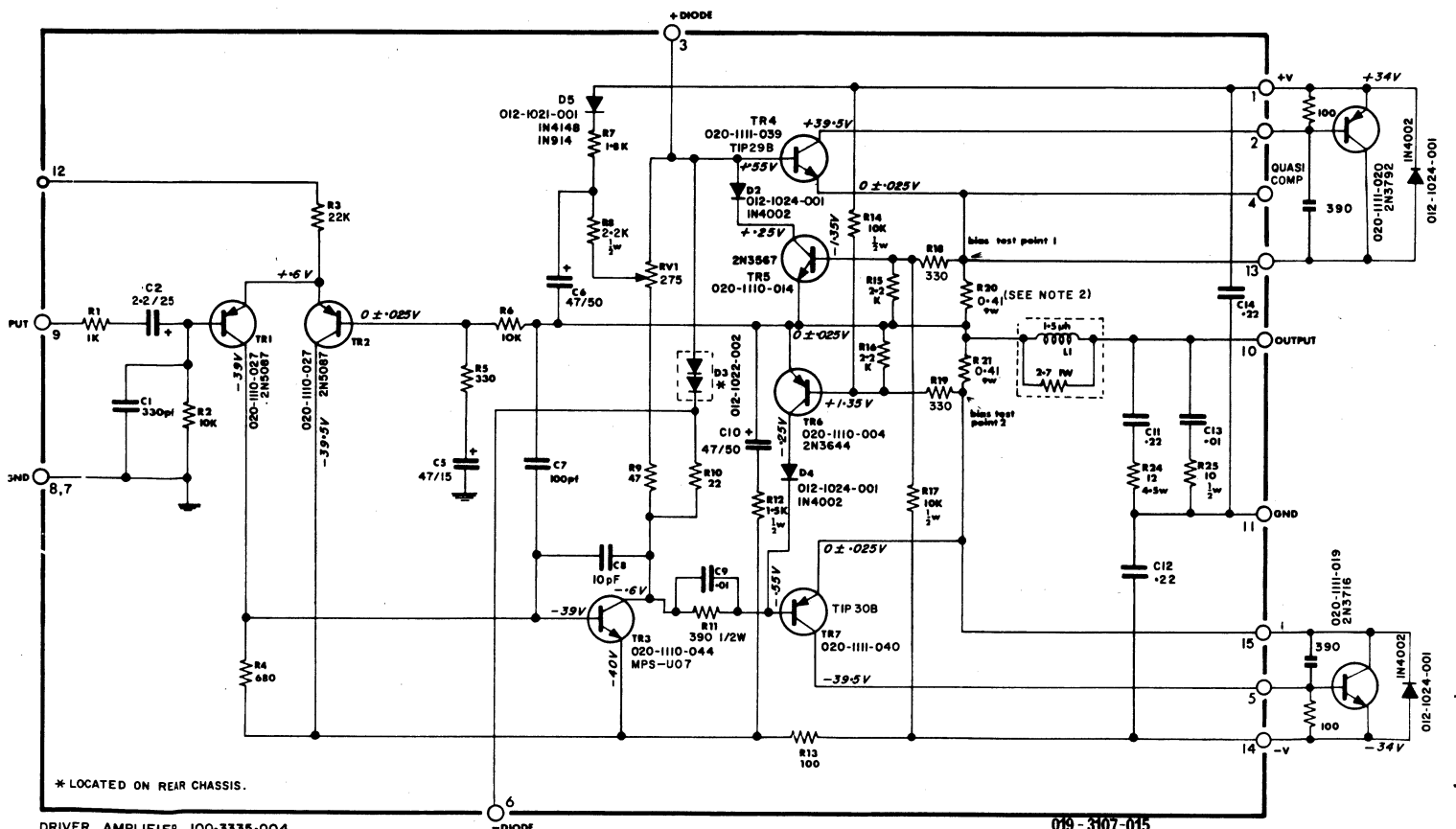

* LOCATED ON REAR CHASSIS.

DRIVER AMPLIFIER 100-3335-004

019-3107-015

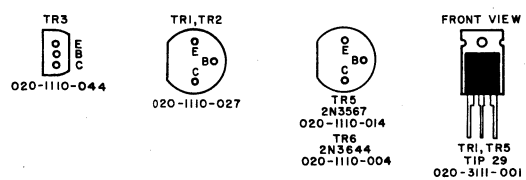

- NOTES:
1. UNLESS OTHERWISE SPECIFIED: ALL RESISTANCE IN OHMS $\pm 10\%$, 1/4 WATT AND CAPACITANCE IN MFD'S.
 2. R20 AND R21 MAY CONSIST OF PARALLEL PAIRS, TWO .82 IN PARALLEL.
 3. ALL VOLTAGES $\pm 10\%$.
 4. HIGHEST SERIES NUMBERS: C14, R25, D5, TR7, RVI
 5. COMPONENTS DELETED: R22, R23, C3, D3, D1, C4
 6. OUTPUT TRANSISTOR CIRCUIT INFORMATION IS DUPLICATED ON OVERALL WIRING DIAGRAM.

TEST PROCEDURE

TEST EQUIPMENT REQUIRED

1. Audio Oscillator
THD less than 0.25%
Frequency range 20-40,000Hz
Output voltage 0-10V rms (600 Ω)
2. DC Voltmeter
Range 1.5V - 150V dc
3. AC Voltmeter
Range 3mV - 30V rms full scale
Input impedance more than 1m
4. Harmonic Distortion Analyzer
Range 1% full scale THD
Input sensitivity 1V rms or better
Frequency range 20-20,000Hz
5. Oscilloscope
Vertical bandwidth 5Hz - 5MHz \pm 3dB
Sensitivity 0.2V/cm or better
6. Volt-Ohm Meter (Multimeter: Triplet Model 630A or equivalent)
DC 20k Ω /V
AC 5k Ω /V
20 Ω internal resistance 12mA DC current scale or DC millivoltmeter
0-100mV full scale
7. FM RF Signal Generator
Range 88-108MHz
Maximum deviation \pm 150kHz
RF output .1 μ V - 100 μ V
Provision for external modulation
THD less than 0.5% at \pm 75kHz deviation at 400Hz
8. FM Multiplex Generator
Minimum 45dB separation
Must have sufficient output to modulate RF generator
9. Resistive Dummy Loads- compensated for L-C; 20Hz - 20kHz
Two 8 Ω loads; 80W minimum
Two 4 Ω loads; 125W minimum
10. Audio Attenuator
1dB step from 0-100dB (not required if Oscillator has attenuator built in)
11. Variac (5A) or regulated 120V line source
12. AM Generator
400Hz modulation (0-100%)
Output: 1 μ V - 1V
Range: 500kHz - 30MHz
Distortion: less than 1%
13. Calibrated Test Loop Antenna (General Radio or equivalent)

Set controls to following positions for test procedure. Deviate from these settings as instructed in the chart below. Return to these settings at the beginning of each new test. All tests should be made with 120V AC line. Unless otherwise specified, supply input to both channels and read both outputs.

Front Panel

Input Selector	Tape 2
Tone Controls	Flat (12 o'clock)
Loudness	Minimum (full CCW)
Balance	12 o'clock
Speaker #1	On (push in)

Rear Panel

Preamp Sensitivity	High (up)
Deemphasis Switch (FM)	75 μ sec. (North America)
	50 μ sec. (Europe and U.K.)

AUDIO TEST

TEST	INPUT	CONTROL SETTINGS	TEST EQUIPMENT	SCALE SETTINGS	MEASURE AT		READINGS	TOL.
					POSITIVE PROBE	NEGATIVE PROBE		
ENP Output transistor	None Unit "OFF"		Triplet 630A	OHMS X 1000	Pin 10 Driver (100-3335-001) R77S (100-3335-002) R75S (100-3335-004) R74S	Pin 1 Driver (100-3335-001) R77S (100-3335-002) R75S (100-3335-004) R74S	1.5kΩ	+150Ω
MIN Output transistor	None Unit "OFF"		Triplet 630A	OHMS X 1000	Pin 10 Driver	Pin 14 Driver	1.5kΩ	+150Ω
B+ Supply	None Unit "ON"	Volume-MINIMUM Selector-FM	Triplet 630A	Volts 60 DC	Pin 1 Driver	Chassis	+44V DC (R77S) +40V DC (R75S) +35V DC (R74S)	+4.4V +4V +3.5V
B- Supply	None Unit "ON"	Volume-MINIMUM Selector-FM	Triplet 630A	Volts 60 DC	Chassis	Pin 14 Driver	-44V DC (R77S) -40V DC (R75S) -35V DC (R74S)	+4.4V +4V +3.5V
Regulated B+ Voltage	None Unit "ON"	Volume-MINIMUM Selector-FM	Triplet 630A	Volts 60 DC	Pin 9 Regulator Pin 8 Regulator (100-3340-001)	Chassis Chassis	+28V DC +13V DC	+2.8V +1.3V
Output Offset Voltage	None Unit "ON"	Volume-MINIMUM Selector-TAPE 2	Triplet 630A DC Milli-volt Meter	12mA DC ≥ 25mV	Speaker #1 "H" Speaker #1 "H"	Speaker #1 "O" Speaker #1 "O"	+1.2 mA +25mV	Max. Max.
Bias Adjust	None Unit "ON"	Set Bias Pot R306 to center of rotation. Allow 5 min. to warm up.	Triplet 630A DC Milli-volt Meter	12mA DC only ≥ 200mV	Pin 13 Driver Pin 13 Driver	Pin 15 Driver Pin 15 Driver	Adjust R306 for 0.2mA DC 0.5mV	+0 +0

AUDIO TEST

TEST	INPUT	CONTROL SETTINGS	TEST EQUIPMENT	SCALE SETTINGS	MEASURE AT		READINGS	TOL.
					POSITIVE PROBE	NEGATIVE PROBE		
Audio Level 8 Ω	1000Hz	Selector-TAPE-2 Mono Switch "IN" Volume-MAXIMUM	AC VTVM Scope	30V 5V/DIV	Speaker #1 "H" 8 Ω load high (75W min. R77S) (50W min. R75S) (40W min. R74S)	Speaker #1 "O" 8 Ω load low	Adjust input for 24.5V (R77S) 20.0V (R75S) 18.0V (R74S) at output. Input level should be .4V. Output not clipped w/ 120V AC line.	
	1000Hz Tape-2	Selector-TAPE-2 Mono Switch "IN" Volume-MAXIMUM	AC VTVM Scope	30V 5V/DIV	Speaker #1 "H" 4 Ω load high (100W min. R77S) (90W min. R75S) (50W min. R74S)	Speaker #1 "O" 4 Ω load low	Adjust input for 20.0V (R77S) 19.0V (R75S) 14.0V (R74S) at output. Wave form should not show clip- ping w/both channels driven at 120V line.	
Phono 1 Sensitivity	1000Hz	Selector- PHONO-1 Volume- MAXIMUM	AC VTVM	30V	Speaker #1 "H" 8 Ω load high	Speaker #1 "O" 4 Ω load low	Adjust input for 24.5V (R77S) 20.0V (R75S) at output. Input should be 6.0mV	+1dB
	1000Hz Phono-1	Selector- PHONO-2 Volume- MAXIMUM Preamp Sens. HIGH	AC VTVM	30V	Speaker #1 "H" 8 Ω load high	Speaker #1 "O" 8 Ω load low	Adjust input for 24.5V (R77S) 20.0V (R75S) at output. Input should be 2.2mV	+1dB
Phono 2 High	1000Hz	Selector- PHONO-2 Volume- MAXIMUM Preamp Sens. LOW	AC VTVM	30V	Speaker #1 "H" 8 Ω load high	Speaker #1 "O" 8 Ω load low	Adjust input for 24.5V (R77S) 20.0V (R75S) at output. Input should be 6mV	+1dB
	1000Hz Phono-2	Selector- PHONO-2 Volume- MAXIMUM Preamp Sens. HIGH	AC VTVM	30V	Speaker #1 "H" 8 Ω load high	Speaker #1 "O" 8 Ω load low	Adjust input for 24.5V (R77S) 20.0V (R75S) at output. Input should be 6mV	+1dB
Phono 2 Low	1000Hz	Selector- PHONO-2 Volume- MAXIMUM Preamp Sens. LOW	AC VTVM	30V	Speaker #1 "H" 8 Ω load high	Speaker #1 "O" 8 Ω load low	Adjust input for 24.5V (R77S) 20.0V (R75S) at output. Input should be 6mV	+1dB
	1000Hz Phono-2	Selector- PHONO-2 Volume- MAXIMUM Preamp Sens. HIGH	AC VTVM	30V	Speaker #1 "H" 8 Ω load high	Speaker #1 "O" 8 Ω load low	Adjust input for 24.5V (R77S) 20.0V (R75S) at output. Input should be 6mV	+1dB
Model R74S Only	Phono-1	Preamp Sens. LOW	AC VTVM	30V	Speaker #1 "H" 8 Ω load high	Speaker #1 "O" 8 Ω load low	6mV for 18V output	+1dB
	Phono-2	Preamp Sens. HIGH	AC VTVM	30V	Speaker #1 "H" 8 Ω load high	Speaker #1 "O" 8 Ω load low	2.2mV	+1dB

AUDIO TEST

TEST	INPUT	CONTROL SETTINGS	TEST EQUIPMENT	SCALE SETTINGS	MEASURE AT		READINGS	TOL.
					POSITIVE PROBE	NEGATIVE PROBE		
Tape Inputs	Tape In 1000Hz	Tape Monitor Sw. - "IN"	AC VTVM	30V	Speaker #1 "H" 8Ω load high	Speaker #1 "O" 8Ω load low	Output of 24.5V (R77S) 20.0V (R75S) 18.0V (R74S) with input of .4V±1dB	
Tape Monitor Output	Tape-2	Selector-TAPE 2 Volume-MAXIMUM	AC VTVM	1V	Tape Out	Ground	Output of .4V with input of .4V	
Speaker 2 and Spkr. 1 & 2	Tape-2 1000Hz	Selector-TAPE 2 Mono Switch-"IN" Volume-MAXIMUM Spkr. 2 in Spkr. 1 & 2 in	AC VTVM	30V	Speaker #2 "H" 8Ω load high	Speaker #2 "O" 8Ω load low	Output 0dB 24.5V (R77S) 20.0V (R75S) 18.0V (R74S) Input of .4V±1dB Same with Speaker 1 & 2 in	
Speaker 3 and Spkr. 1 & 3 (R77S & R75S) Speaker 2 and Spkr. 1 & 2 (R74S)	Tape-2 1000Hz	Selector-TAPE 2 Mono Switch-"IN" Volume-MAXIMUM Spkr. 3 or Spkr. 1 & 3 Spkr. 2 or Spkr. 1 & 2	AC VTVM	30V	Speaker #3 "H" 8Ω load high (R77S & R75S) Speaker #2 "H" 8Ω load high (R74S)	Speaker #3 "O" 8Ω load low (R77S & R75S) Speaker #2 "O" 8Ω load low (R74S)	Output 24.5V (R77S) 20.0V (R75S) 18.0V (R74S) Input .4V±1dB Same with Spkr. 1&3 Same with Spkr. 1&2	
Frequency Response Power Amp & Tone Control	Tape-2 (20Hz to 20kHz)	Tone Control-FLAT Volume-MAXIMUM Adjust balance for center	AC VTVM	1V	Speaker #3 "H" 8Ω load high (R77S & R75S) Speaker #2 "H" 8Ω load high (R74S)	Speaker #3 "O" 8Ω load low (R77S & R75S) Speaker #2 "O" 8Ω load low (R74S)	Adjust input for 0dB (.775V) out. (3dB down points should be below 10Hz and above 30kHz)	±1dB

AUDIO TEST

TEST	INPUT	CONTROL SETTINGS	TEST EQUIPMENT	SCALE SETTINGS	MEASURE AT		READINGS	TOL.
					POSITIVE PROBE	NEGATIVE PROBE		
Frequency Response Phono (RIAA)	Phono-2 1000Hz	Selector- PHONO 2 Keep settings listed above	AC VTVM	1V	Speaker #3 "H" 8Ω load high (R77S & R75S) Speaker #2 "H" 8Ω load high (R74S)	Speaker #3 "O" 8Ω load low (R77S & R75S) Speaker #2 "O" 8Ω load low (R74S)	Adjust input for 0dB (.775V) out Note: 100Hz +12.5dB 10kHz -13.0dB	+1dB
Tone Control Response	Tape-2 1000Hz	Selector- TAPE 2 Mono Switch- "IN" Tone Control- FLAT	AC VTVM	3V	Speaker #3 "H" 8Ω load high (R77S & R75S) Speaker #2 "H" 8Ω load high (R74S)	Speaker #3 "O" 8Ω load low (R77S & R75S) Speaker #2 "O" 8Ω load low (R74S)	Adjust output for -10dB Note: 100Hz Base boost +10dB Base Cut -10dB 10kHz Treble boost +10dB Treble cut -10dB	+2dB +2dB
Filter	Tape-2 10kHz	Selector- TAPE 2 Tone Control FLAT Mono Switch- IN Balance Cont- for equal balance	AC VTVM	3V	Speaker #3 "H" 8Ω load high (R77S & R75S) Speaker #2 "H" 8Ω load high (R74S)	Speaker #3 "O" 8Ω load low (R77S & R75S) Speaker #2 "O" 8Ω load low (R74S)	Adjust output for 0dB Filter Switch-IN Note: -10dB	+2dB
Loudness Compensation	Tape-2 1000Hz	Selector- TAPE 2 Tone Control FLAT Volume-#4 Filter Sw.- OUT	AC VTVM	3V	Speaker #3 "H" 8Ω load high (R77S & R75S) Speaker #2 "H" 8Ω load high (R74S)	Speaker #3 "O" 8Ω load low (R77S & R75S) Speaker #2 "O" 8Ω load low (R74S)	Adjust output for -10dB. Frequency, 10kHz; Note 1dB in- crease. Frequency to 100Hz; Note 7dB increase	+2dB +2dB

AUDIO TEST

TEST	INPUT	CONTROL SETTINGS	TEST EQUIPMENT	SCALE SETTINGS	MEASURE AT		READINGS	TOL.
					POSITIVE PROBE	NEGATIVE PROBE		
Crosstalk	Tape-2 Left Channel 1000Hz	Selector-TAPE-2 Tone Contr.-FLAT Comp. Switch-CUT Volume Contr.-MAXIMUM	AC VTVM	3V	Speaker #3 "H" 8Ω load high (R77S & R75S) Speaker #2 "H" 8Ω load high (R74S)	Speaker #3 "O" 8Ω load low (R77S & R75S) Speaker #2 "O" 8Ω load low (R74S)	Set output for 0dB Read right channel output 40dB down Set output for 18.0V Read right channel output 40dB down	Min. Min.
Balance Control	Tape-2 Left Channel 1000Hz Right Channel 1000Hz	Same as above Mode Switch IN Balance CCW Balance CW	AC VTVM	30V	Speaker #3 "H" 8Ω load high (R77S & R75S) Speaker #2 "H" 8Ω load high (R74S)	Speaker #3 "O" 8Ω load low (R77S & R75S) Speaker #2 "O" 8Ω load low (R74S)	Set output for 0dB Note 45dB drop in output. Note 45dB drop in output	+2dB +2dB
Harmonic Distortion	Tape 2 50Hz 100Hz 10,000Hz	Selector-TAPE 2 Mode Switch IN Balance Cont. CENTER Volume-MAXIMUM	AC VTVM Harmonic Distortion Analyzer	30V	Speaker #3 "H" 8Ω load high (R77S & R75S) Speaker #2 "H" 8Ω load high (R74S)	Speaker #3 "O" 8Ω load low (R77S & R75S) Speaker #2 "O" 8Ω load low (R74S)	Set output to 24.5V (R77S) 20.0V (R75S) 18.0V (R74S) Distortion: ≤ 0.5% @ { 50Hz 1000Hz 10,000Hz	
Damping Factor	Tape 2 1000Hz	Selector-TAPE 2 Mode Switch IN Balance Cont. CENTER Volume-MAXIMUM	AC VTVM	30V	Speaker #3 "H" 8Ω load high (R77S & R75S) Speaker #2 "H" 8Ω load high (R74S)	Speaker #3 "O" 8Ω load low (R77S & R75S) Speaker #2 "O" 8Ω load low (R74S)	Set output to 24.5V (R77S) 20.0V (R75S) 18.0V (R74S) Remove & note increase in level ≤ 0.5dB	

FM TEST

FM TUNER SECTION (Includes Multiplex)

This procedure assumes that all subassemblies are properly presigned. In the case of a badly misaligned unit, it would be best to align the IF amplifier and the Multiplex before aligning the front end. In the normal case, the technician should rely on the oscilloscope indication for center tuning while peaking the front end since the center-tune meter is adjusted after the front end.

Controls should be set as per Basic Control settings for the Audio Tests, except that the selector should be set to "FM". Connect the balanced input attenuator to the 300 ohm terminals (see figure FM-1). Use 400 Hz modulation and ± 75 kHz deviation, unless otherwise specified. All signals should be observed at the TAPE OUTPUT JACKS during adjustment of the front end, IF amplifier and multiplex.

FIGURE FM-1

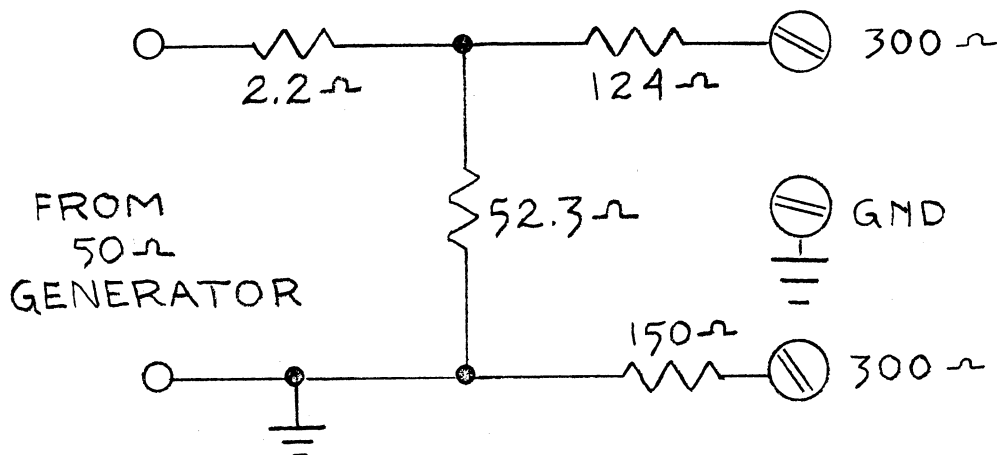

Note:-- All resistors $\frac{1}{2}$ watt carbon. All resistors should be bridge or DVM selected.

FM TEST

J FET
FIGURE FM-2

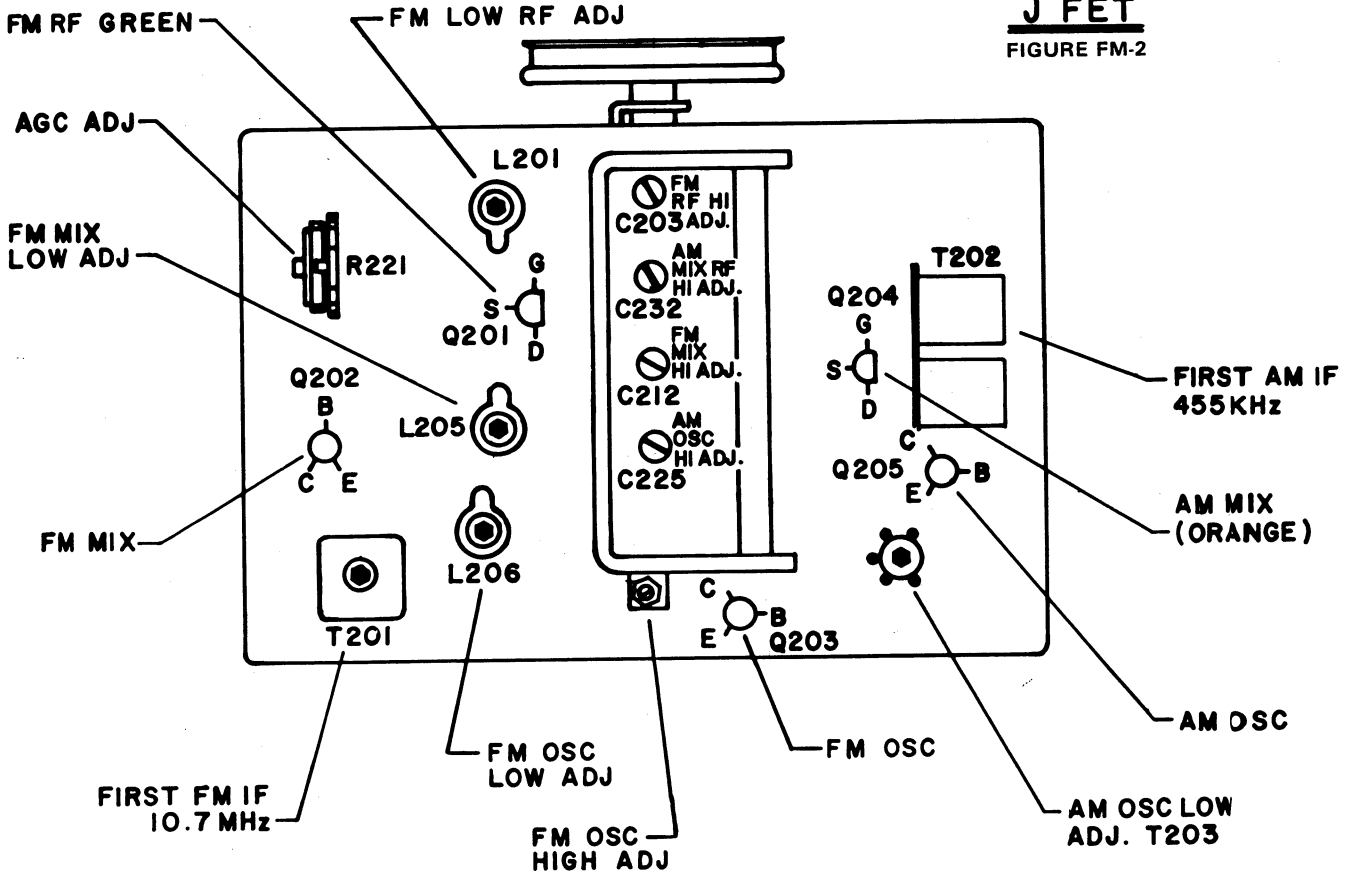

MOS FET
FIGURE FM-3

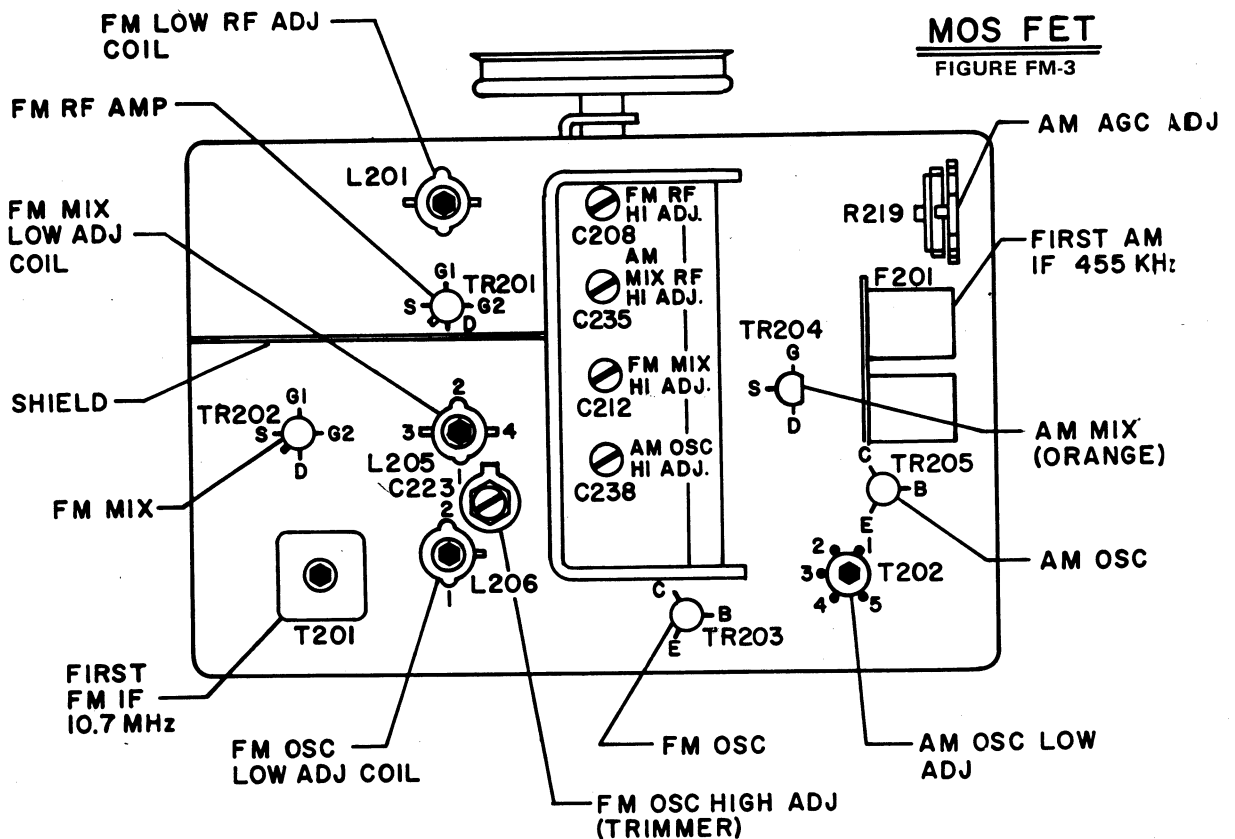

FRONT END COMPONENT IDENTIFICATION

FM TEST

TEST	GENERATOR	COMPONENT ADJUSTED	ADJUST FOR
1. First IF Can on Front End	10.7 MHz signal Source Loose couple to input of Front End	T201 (see figure FM-2 & FM-3)	Maximum Signal Strength Meter indication
2. a) OSC trimmer b) ANT trimmer c) MIX trimmer	FM Generator to 106 MHz Set output level to produce 20dB S/N ratio.	Figures: FM-2 FM-3 a) C217 C223 b) C203 C208 c) C212 C212	a) Max. audio output b) Max. audio output c) Max. audio output Dial pointer on 106 MHz
3. a) OSC coil b) ANT coil c) MIX coil	FM Generator to 90 MHz Set output level to produce 20dB S/N ratio.	a) L206 } see b) L201 } fig. c) L205 } FM-2 } or } FM-3	a) Max. audio output b) Max. audio output c) Max. audio output Dial pointer on 90 MHz
4. Repeat steps 2 & 3 in their entirety until no further improvement can be made. Minimum IHF sensitivity is 1.9 μ V at 90 MHz and 106 MHz. Check calibration against stations. Tolerance \pm 200 kHz.			
5. Signal Strength Meter	Any FM frequency Set RF output for 50 μ V at antenna (100 μ V from generator)	None	Signal strength meter should read halfscale or better
6. Detector Alignment & distortion	FM Generator to 90 MHz Output 7 μ V	T1 Top & Bottom slugs. (100-3331-001 IF)	Bottom slug for max. output. Top slug for min. distortion. It should be \leq .5% Unit should be tuned exactly to 90 MHz.
7. Center Tune Meter Adjust	90 MHz 7 μ V 90 MHz 100 μ V	Adjust receiver Adjust RV1 on IF	Equal noise on peaks of sine wave on scope. Center-tune indication on meter.
8. Output Level	FM Generator to any FM frequency. 1000 μ V from generator. (mono, but keep receiver in stereo mode) <u>+75 kHz deviation</u>	None	Output should be between 2.0 & 4.0V No more than 1dB difference between channels. Distortion \leq 0.6% @ 400 Hz

FM TEST

TEST	GENERATOR	COMPONENT ADJUSTED	ADJUST FOR
9. 19 kHz Pilot Alignment	FM stereo generator at 98 MHz with accurate 19 kHz pilot.	RV3 (on multiplex) Initially set at either extreme.	Rotate RV3 until stereo light comes on. Note this setting. Continue to rotate RV3 until stereo light goes off. Note this setting and set pot halfway between two noted settings.
10. Separation Pot Adjustment	Modulated (1kHz) stereo signal on Left Channel.	Adjust RV1 VTVM connected to Right Channel.	Adjust RV1 for minimum output level. Reverse channels and check for equal separation of 35dB minimum and within ± 2 dB between channels.
11. Muting Adjustment	Reduce FM generator to 0 μ V	Push 'Muting' Switch on.	Adjust RV2 slightly beyond point at which tuner mutes.
12. Hum	Increase FM generator output level to 100 μ V with unmodulated RF.	None	Output should be ≤ 60 dB @ ± 75 kHz modulation.
13. Deemphasis a) 75 μ sec. b) 50 μ sec.	Tune to a strong FM mono signal with 400Hz and 8200Hz modulation.	Deemphasis sw. 75 μ sec. Deemphasis sw. 50 μ sec.	8200Hz output should be 12dB below 400Hz 8200Hz output should be 9.5dB below 400Hz output.

AM TEST

AM Tuner Section

Controls should be set as per Basic Control settings for the Audio Tests, except that the selector should be set to "AM". All signals should be observed at the tape output jacks.

Before commencing the tests, close the tuning capacitor (plates fully meshed) and adjust the dial pointer to the left end of the line for the AM dial scale.

After alignment, slowly tune across the AM band and listen for oscillations and/or no output (indicating shorting tuning capacitor plates). Connect an outside antenna and note calibration using local broadcast stations.

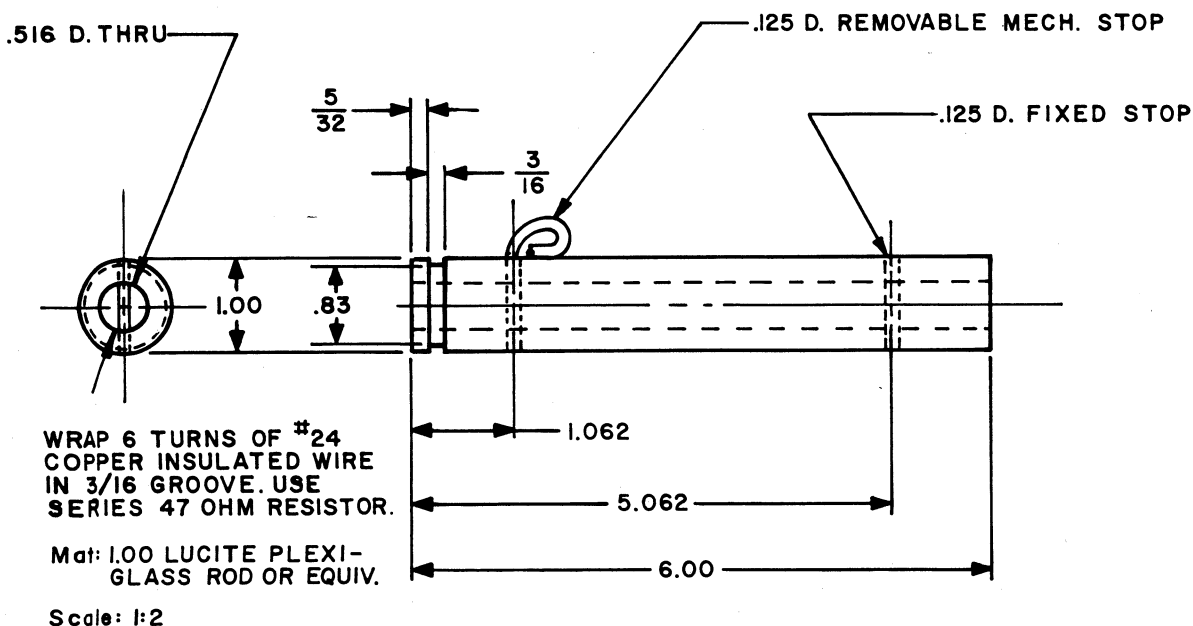

FORM FOR AM COUPLING LOOP

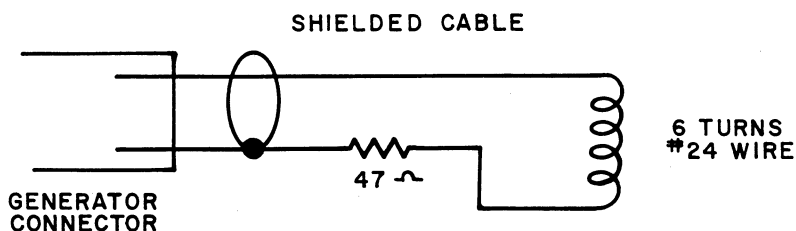

CIRCUIT FIGURE AM-1

AM TEST

TEST	INPUT	GENERATOR	COMPONENT ADJUSTED	ADJUST FOR
1. IF Amp Peak	External AM antenna input (remove shorting bar)	455kHz, 30% @ 400Hz 2000 μ V	T302 and T301 on 100-1331-023 IF	Max. output
2. a) OSC Coil Adjust	AM coupling loop, 1" penetration. See fig. AM-1. Be sure to replace shorting bar.	600kHz, 60% @ 400Hz	T203 fig. FM-2 T202 fig. FM-3	Max. output. Then reduce signal input until signal is barely visible on scope. Sensitivity at maximum. Readjust T203 for maximum output.
b) OSC Trimmer adjust	AM coupling loop, 1" penetration. See fig. AM-1. Be sure to replace shorting bar.	1600kHz, 60% @ 400Hz	C225 fig. FM-2 C238 fig. FM-3	Repeat above procedure except adjust C225 or C238.
3. Repeat both parts of step 2 above, until no further improvement can be made.				
4. Mixer Trimmer	AM coupling loop, 1" penetration	1400kHz, 60% @ 400Hz	C232 fig. FM-2 C235 fig. FM-3	Max. output. Keep RF signal weak.
5. AGC Adjust	AM coupling loop, full 5" penetration (remove stop)	600kHz, 60% @ 400Hz, 200 μ V input to loop.	R221 fig. FM-2 R219 fig. FM-3	0.95V audio output. Then return AM coupling loop to 1" penetration (use mech. stop) and observe less than 0.3V drop in audio output.
6. 600kHz Measurements	AM coupling loop, 1" penetration	600kHz, 60% @ 400Hz, 500 μ V RF then 10 μ V		Note audio output, should be between 0.65V and 1.25V from tape out jacks. Reading should not drop more than 3dB when RF output is attenuated to 10 μ V from 500 μ V.
7. 1000Hz Measurements	AM coupling loop, 1" penetration	1000kHz, 60% @ 400Hz, 500 μ V RF, then 10 μ V		Note audio output, should be between 0.65V and 1.25V from tape out jacks. Reading should not drop more than 3dB when RF output is attenuated to 10 μ V from 500 μ V.

AM TEST

TEST	INPUT	GENERATOR	COMPONENT ADJUSTED	ADJUST FOR
1400 kHz measurement	AM coupling loop, 1" penetration	1400 KHz, 60% @ 400 Hz, 620 μ V RF, then 10 μ V		Note audio output, should be between 0.65V and 1.25V from tape out jacks. Reading should not drop more than 3 dB when RF output is attenuated to 10 μ V from 620 μ V.
Distortion measurement	AM coupling loop, 1" penetration	1000 KHz, 60% @ 400 Hz, 500 μ V RF		Measure audio distortion at tape output jack; total Harmonic distortion should not exceed 2%.
0. Calibration	AM coupling loop, 1" penetration Use SS meter peak to indicate proper tuning.	Set RF level for 10 μ V, 60% 400 Hz 600 KHz 800 KHz 1000 KHz 1200 KHz 1400 KHz 1600 KHz		Check calibration as follows: pointer should read: 600 KHz \pm 10 KHz 800 KHz \pm 10 KHz 1000 KHz \pm 10 KHz 1200 KHz \pm 10 KHz 1400 KHz \pm 10 KHz 1600 KHz \pm 10 KHz
1. Meter check	AM coupling loop, 1" penetration	Noise-then 600 μ V RF signal		Meter should read in first block on noise under normal household conditions; meter should read no lower than first block with 600 μ V RF input.

PARTS LIST

QTY.

PER UNIT

H.H.S. PART NUMBER

DESCRIPTION

QTY.	H.H.S. PART NUMBER	DESCRIPTION	
2	011-1000-001	Ceramic Capacitor	.001 Mfd.
4	011-1000-003	Ceramic Capacitor	.005 Mfd.
2	011-1000-005	Ceramic Capacitor	.0015 Mfd.
2	011-1000-010	Ceramic Capacitor	.0047 Mfd.
1	011-1000-012	Ceramic Capacitor	.0056 Mfd.
1	011-1000-018	Ceramic Capacitor	.02 Mfd.
4	011-1000-055 (R74S only)	Ceramic Capacitor	390 pF
1	011-1000-060	Ceramic Capacitor	.001 Mfd/1.4kV
2	011-1000-073	Ceramic Capacitor	.0047 Mfd/1.4kV
4	011-1004-029 (R77S only)	Filter Capacitor	5000/50V
2	011-1004-029 (R75S & R74S)	Filter Capacitor	5000/50V
1	011-1006-048	Electrolytic Capacitor	1000/55V
1	011-1006-052	Electrolytic Capacitor	250/15V
4	011-1008-008	Mylar Capacitor	.22/250V
1	011-1008-010	Mylar Capacitor	.47/250V
2	012-1022-002	Dual Diode	
4	012-1024-001	Rectifier	0.5A/100 PIV
1	012-1024-002	Rectifier	0.1A/200 PIV
1	012-1025-002	Bridge Rectifier	10A/200 PIV
1	013-1031-008 (R74S only)	Fuse, Slo-Blo	1.25A/250V
1	013-1031-011 (R74S only)	Fuse, Slo-Blo	2.5A/125V
1	013-1031-013 (R77S only)	Fuse, Slo-Blo	5A/125V
1	013-1031-015 (R75S only)	Fuse, Slo-Blo	3.2A/125V
2	013-1031-017 (R77S & R75S)	Fuse, Speaker	5A/32V
1	013-1031-019 (R75S only)	Fuse, Slo-Blo	1.6A/250V
1	013-1031-020 (R77S only)	Fuse, Slo-Blo	2.5A/250V
2	013-1031-021 (R74S only)	Fuse, Speaker	4A/250V
1	015-1061-005	Phone Jack	
1	015-1065-009	AM Antenna Jack	
1	015-1065-017	75ohm Antenna Jack (not found in R74S)	
2	015-1070-002	Shorting Link	
1	015-1075-013	75ohm Antenna Plug (not found in R74S)	
1	015-1075-014	AC Switching Plug	
1	017-1095-033	Meter, Signal Strength	} Order only in pairs
1	017-1095-034	Meter, Center Tune	
11	018-1100-097 (R77S & R75S)	Push-Button Knob	
8	018-1100-097 (R74S only)	Push-Button Knob	
1	018-1100-152	Tuning Knob	
5	018-1100-153	Function Knob	
1	018-1102-137 (R77S)	Front Panel	
1	018-1102-138 (R75S)	Front Panel	
1	018-1102-139 (R74S)	Front Panel	
1	018-1104-081	Plexi-Glass Inlay	
1	018-1105-108	Dial	
2	020-1111-019 (R74S)	Power Transistor	NPN
2	020-1111-020 (R74S)	Power Transistor	PNP
2	020-1111-023 (R77S & R75S)	Power Transistor	NPN
2	020-1111-024 (R77S & R75S)	Power Transistor	PNP
1	021-1121-022 (R77S & R75S)	1/2w Resistor	820ohm
1	021-1121-058	1/2w Resistor	820K
1	021-1121-064	1/2w Resistor	2.7M
1	021-1131-037	1/2w Resistor	33ohm
2	021-1131-041	1/2w Resistor	47ohm
4	021-1131-049	1/2w Resistor	100ohm
1	021-1131-051 (R74S only)	1/2w Resistor	120ohm
1	021-1131-057	1/2w Resistor	220ohm

PARTS LIST

QTY. UNIT	H.H.S. PART NUMBER	DESCRIPTION	
2	021-1131-067 (R77S only)	1/2w Resistor	560ohm
1	021-1131-071 (R77S only)	1/2w Resistor	820ohm
3	021-1131-071 (R75S & R74S)	1/2w Resistor	820ohm
1	021-1131-101	1/2w Resistor	15K
2	021-1131-113	1/2w Resistor	47K
2	021-1131-123	1/2w Resistor	120K
2	021-1131-129	1/2w Resistor	220K
1	023-1137-072	Rotary Switch	
1	024-1140-062 (R77S)	Power Transformer	
1	024-1140-065 (R75S)	Power Transformer	
1	024-1140-066 (R74S)	Power Transformer	
1	026-1152-009	Power Cord (USA)	
1	026-1152-011	Power Cord (European)	
1	028-1165-133	Carton	
1	028-1166-213	Filler, Wrap-Around	
1	028-1166-214	Filler, Back	
1	028-1166-215	Filler, Front	
2	028-1166-216 (R77S only)	Filler, Side	
1	028-1168-016	Poly Bag	
1	030-1181-016	Terminal Lug	
8	030-1181-029	6 Post Amp Connector	
3	030-1181-031	3 Post Amp Connector	
1	030-1183-008	Terminal Lug	
1	030-1187-024	Terminal, Ground	
6	030-1189-013 (R77S & R75S)	Function Lamp	
1	030-1189-013 (R74S)	Function Lamp	
7	030-1189-019	Dial Lamp	
5	030-1190-011	Dial Lamp Socket	
2	030-1190-013	Meter Lamp Socket	
2	030-1192-001	Channel Fuse Holder	
1	030-1192-006	Power Fuse Holder	
1	030-1194-007	AC Receptacle	
1	031-1197-034	Dial Cord	
1	031-1198-024	Pointer Assembly	
4	031-1200-006	Feet	
1	100-1330-037	Front End Assembly	
1	100-1331-040	FM/IF Assembly	
1	100-1331-023	AM/IF Assembly	
1	100-1334-019 (R77S & R75S)	Tone Control Assembly	
1	100-1334-018 (R74S)	Tone Control Assembly	
1	100-1348-004	Balun Assembly	
1	100-1352-016 (R74S)	Speaker Switch Assembly	
1	100-1352-017 (R77S & R75S)	Function Switch Assembly	
1	100-1352-018 (R77S & R75S)	Speaker Switch Assembly	
1	100-3332-001	Multiplex Assembly	
1	100-3333-001	Pre-Amp Assembly	
2	100-3335-001 (R77S)	Driver Assembly	
2	100-3335-002 (R75S)	Driver Assembly	<i>inches - Platine</i>
2	100-3335-004 (R74S)	Driver Assembly	
1	110-1404-007	Flywheel Assembly	
2	110-1407-008 (R77S & R75S)	Heat Sink Assembly	
2	110-1407-010 (R74S)	Heat Sink Assembly	
1	110-1410-003	Antenna Bracket Assembly	
1	110-1406-007	Dial Pointer Track Assembly	
1	110-1452-026	AM Antenna Assembly	

CHASSIS LAYOUT R74S

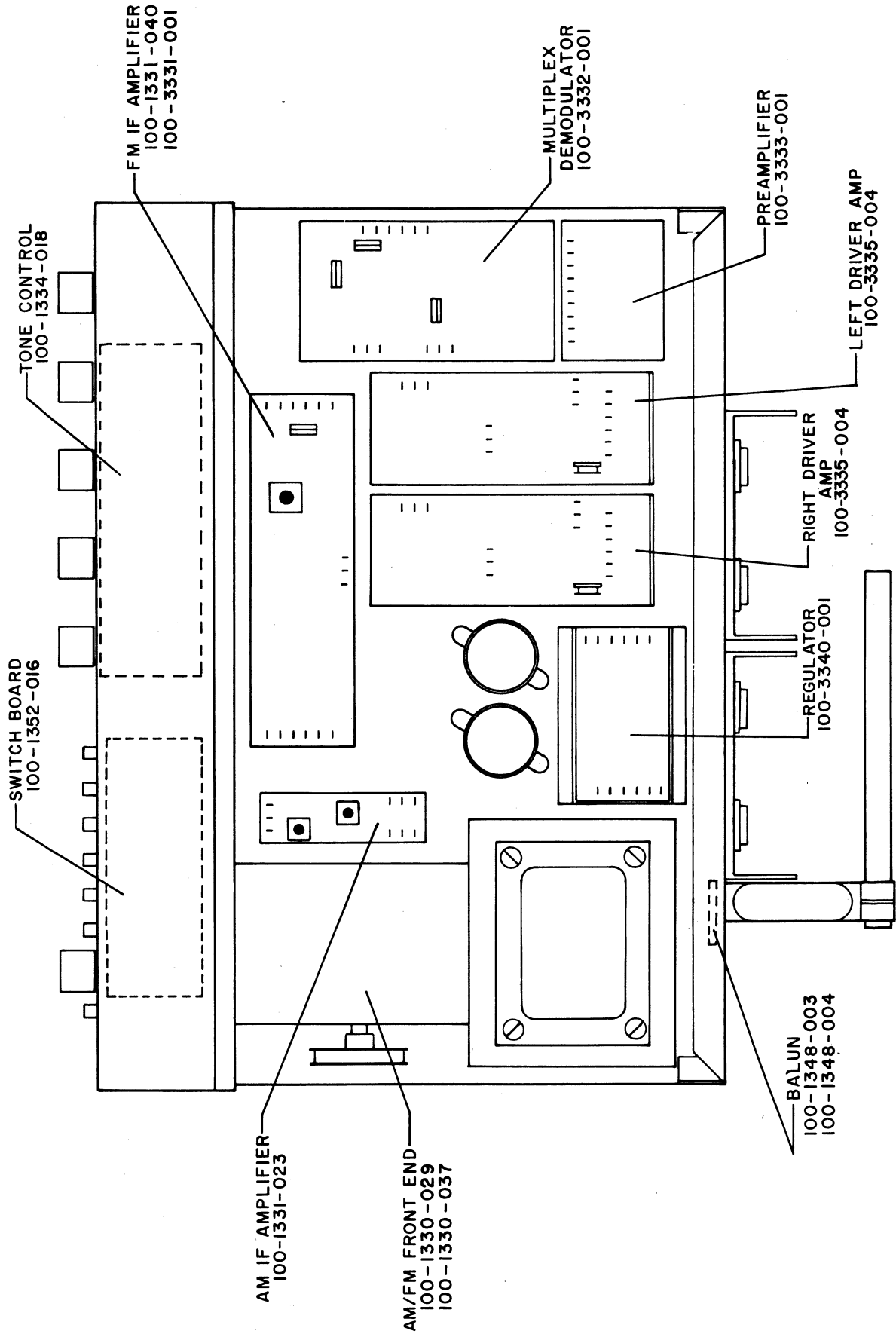

CHASSIS LAYOUT R75S

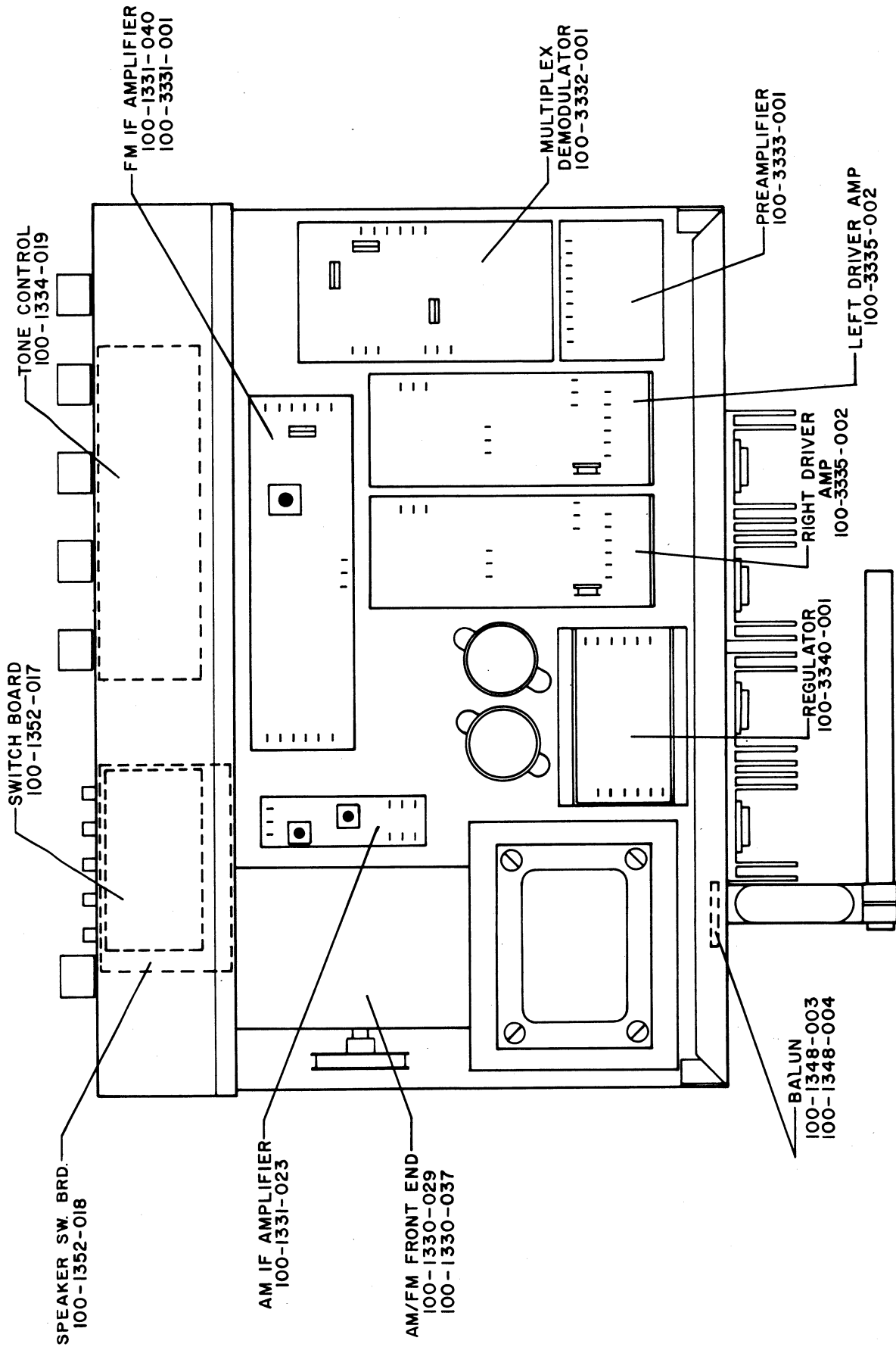

CHASSIS LAYOUT R77S

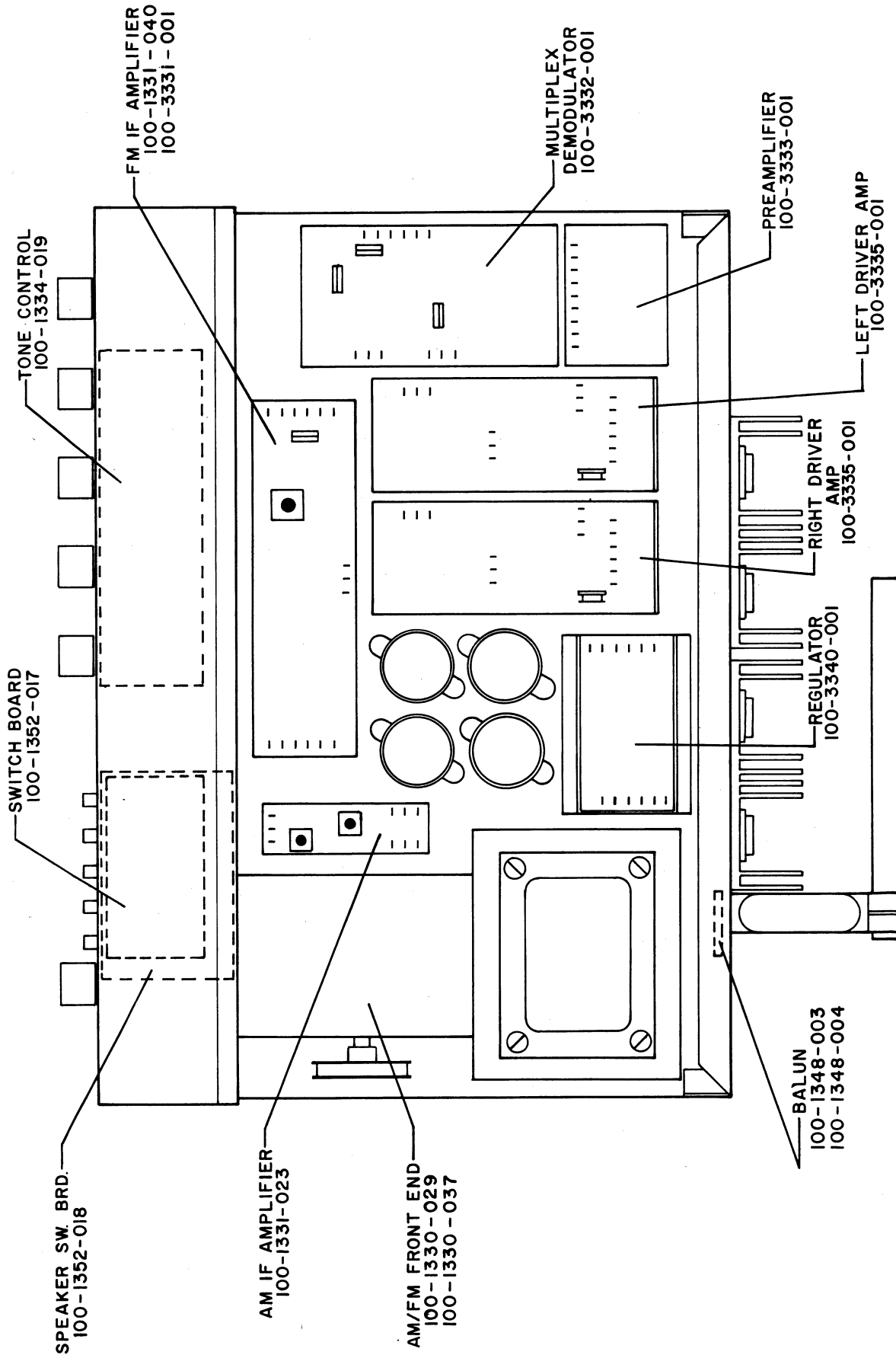

ADDENDUM

Chassis layouts on pages 32 through 34 and overall circuit diagrams on pages 36 through 43 apply to receivers with Serial Numbers as follows:

0415500 and above	R74S
0408000 and above	R75S
0404150 and above	R77S

For receivers with lower Serial Numbers, note the following module changes:

- 1) Balun 100-1348-003
(PC layout and circuit diagram on page 1)
- 2) AM/FM Front End 100-1330-029
(PC layout and circuit diagram on page 2)
- 3) FM IF 100-3331-001
(PC layout and circuit diagram on page 5)

DIAL CORD ARRANGEMENT

- 1) Remove old dial cord from unit, saving all springs that are attached to dial cord.
- 2) Rotate tuning capacitor dial drum to its maximum clockwise position. String cord with rear of unit facing you.
- 3) Attach middle loop in dial cord to spring on dial drum.
- 4) Wrap short length portion of dial cord around arm of dial drum and run dial cord over stud in slot at rear of dial drum. Wrap short length around drum $1\frac{1}{2}$ times and leave resting there.
- 5) Start long length of dial cord from stud in slot at front of dial drum. Place over pulley 'A' and then wrap three full turns around flywheel pulley in direction shown in diagram. Now place dial cord around pulleys 'B', 'C', and 'D' in that sequence.
- 6) Attach larger spring to both ends of dial cord and then loop dial cord over and around pulley 'E'.
- 7) Attach dial cord to pointer under tabs at rear of dial pointer.

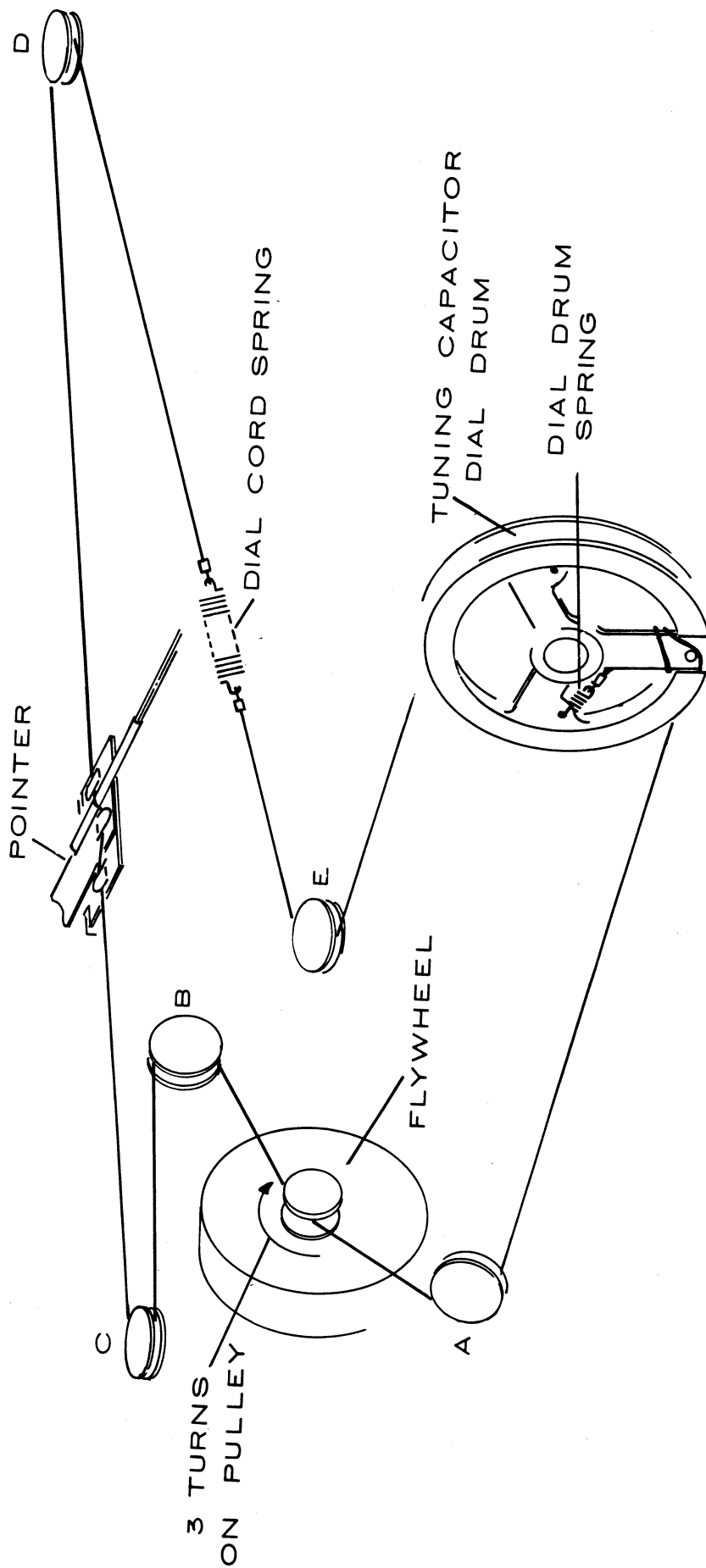

FOR USE WITH
SINGLE VOLTAGE
TRANSFORMER ONLY.
SEE NOTE 11.

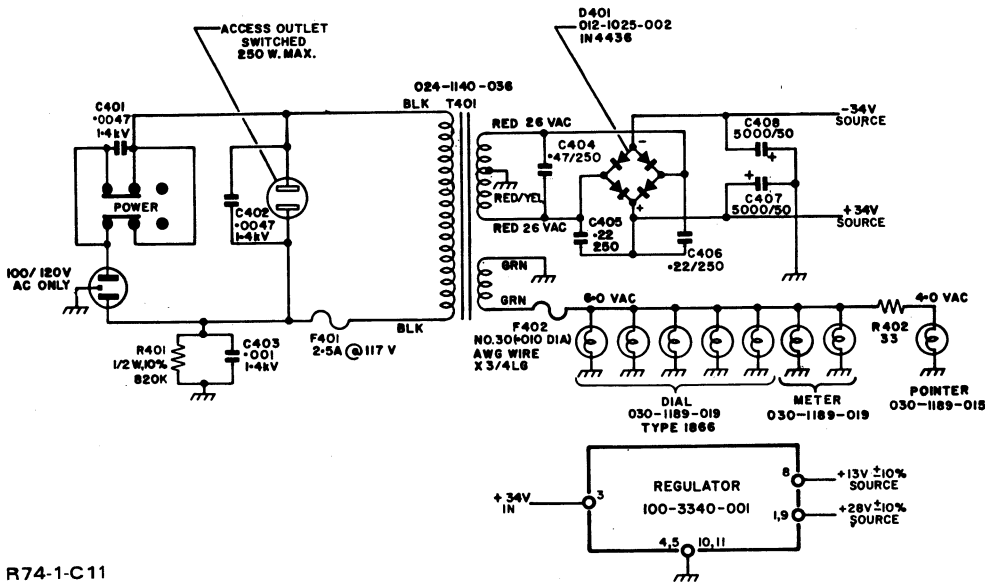

R74-1-C11

NOTES:

1. RESISTANCE IN OHMS $\pm 10\%$ 1/4 WATT, CAPACITANCE IN MFD'S, UNLESS OTHERWISE SPECIFIED.
2. ARROW HEADS INDICATE MAIN SIGNAL PATH.
3. VOLTAGES ALSO SHOWN ON SUBASSEMBLY DIAGRAMS.
4. UNLESS OTHERWISE SPECIFIED, ALL D.C. VOLTAGES $\pm 15\%$ MEASURED WITH RESPECT TO CHASSIS GROUND, USING 20K Ω /V VOM AT 120 VAC LINE, 300 Ω EXTERNAL ANTENNA, TUNER OFF STATION AND INPUT IN "FM" POSITION.
5. D.C. OFFSET VOLTAGE
WITH NO SIGNAL APPLIED, READ 0 VOLTS ± 25 mV AT SPEAKER 1 OUTPUT TERMINAL. (25mV IS 1.25mA ON TRIPLETT 630A 12mA SCALE).
6. BIAS CURRENT OF THE POWER AMP P.C. BOARD SHALL BE MEASURED AS FOLLOWS: VOM SET TO MEASURE D.C. CURRENT. MINUS OR COMMON PROBE OF VOM TO PIN 15 AND POSITIVE TO PIN 13 OF DRIVER AMPLIFIER BOARD. READ 1.2mA ON TRIPLETT 630A ON 12mA SCALE. USE SAME PROCEDURE FOR OTHER CHANNEL. ALLOW 5 MINUTE WARM-UP BEFORE ADJUSTING BIAS.
7. FM AGC VOLTAGE (FRONT END A.G.C. TERMINAL) $+10$ TO -2.10 V WITH 0 TO 100 μ V SIGNAL FED INTO 300 Ω EXTERNAL FM ANTENNA. AM A.G.C. VOLTAGE 0 TO -4.7 V WITH 0 TO 500 μ V SIGNAL FED TO LOOPSTICK WITH ANTENNA COUPLER PER TEST SPEC.
8. HIGHEST SERIES NUMBERS ARE: R6, R106, R402, R607, C6, C106, C408, C606, D3, D103, D601, D401, F1, F101, F402, L601, S601, T401, TR2, TR102.
9. THE FOLLOWING CONTROLS IN THE LEFT CHANNEL ARE MECHANICALLY GANGED WITH IDENTICAL CONTROLS IN THE RIGHT CHANNEL. BASS, TREBLE AND VOLUME CONTROL.
10. ROTARY SWITCH S601 SHOWN IN MAX COUNTER CLOCKWISE POSITION (POS 1). POSITIONS ARE:
1 PHONO 1
2 PHONO 2
3 FM
4 AM
5 TAPE 2
(FRONT DECK SHOWN FROM KNOB END AND REAR DECK SHOWN FROM END OPPOSITE KNOB)
11. CIRCUIT IS APPLICABLE TO UNITS WITH SERIAL NUMBERS:
0413601 - 0414100

NOTES:

1. RESISTANCE IN OHMS $\pm 10\%$ 1/4 WATT, CAPACITANCE IN MFD'S, UNLESS OTHERWISE SPECIFIED.
2. ARROW HEADS INDICATE MAIN SIGNAL PATH.
3. VOLTAGES ALSO SHOWN ON SUBASSEMBLY DIAGRAMS.
4. UNLESS OTHERWISE SPECIFIED, ALL D.C. VOLTAGES $\pm 15\%$ MEASURED WITH RESPECT TO CHASSIS GROUND, USING 20K Ω /V VOM AT 120 VAC LINE, 300 Ω EXTERNAL ANTENNA, TUNER OFF STATION AND INPUT IN "FM" POSITION.
5. D.C. OFFSET VOLTAGE
WITH NO SIGNAL APPLIED, READ 0 VOLTS ± 25 mV AT SPEAKER 1 OUTPUT TERMINAL. (25mV IS 1.25mA ON TRIPLETT 630A 12mA SCALE).
6. BIAS CURRENT OF THE POWER AMP P.C. BOARD SHALL BE MEASURED AS FOLLOWS: VOM SET TO MEASURE D.C. CURRENT. MINUS OR COMMON PROBE OF VOM TO PIN 15 AND POSITIVE TO PIN 13 OF DRIVER AMPLIFIER BOARD. READ 1.2mA ON TRIPLETT 630A ON 12mA SCALE. USE SAME PROCEDURE FOR OTHER CHANNEL. ALLOW 5 MINUTE WARM-UP BEFORE ADJUSTING BIAS.
7. FM AGC VOLTAGE (FRONT END A.G.C. TERMINAL) $+10$ TO -2.10 V WITH 0 TO 100 μ V SIGNAL FED INTO 300 Ω EXTERNAL FM ANTENNA. AM A.G.C. VOLTAGE 0 TO -4.7 V WITH 0 TO 500 μ V SIGNAL FED TO LOOPSTICK WITH ANTENNA COUPLER PER TEST SPEC.
8. HIGHEST SERIES NUMBERS ARE: R6, R106, R402, R607, C6, C106, C408, C606, D3, D103, D601, D401, F1, F101, F402, L601, S601, T401, TR2, TR102.
9. THE FOLLOWING CONTROLS IN THE LEFT CHANNEL ARE MECHANICALLY GANGED WITH IDENTICAL CONTROLS IN THE RIGHT CHANNEL. BASS, TREBLE AND VOLUME CONTROL.
10. ROTARY SWITCH S601 SHOWN IN MAX COUNTER CLOCKWISE POSITION (POS 1). POSITIONS ARE:
1 PHONO 1
2 PHONO 2
3 FM
4 AM
5 TAPE 2
(FRONT DECK SHOWN FROM KNOB END AND REAR DECK SHOWN FROM END OPPOSITE KNOB)
11. CIRCUIT IS APPLICABLE TO UNITS WITH SERIAL NUMBERS:
0414101 - 414500

R74S-2-C11

FOR USE WITH
DUAL VOLTAGE
TRANSFORMER ONLY.
SEE NOTE 11.

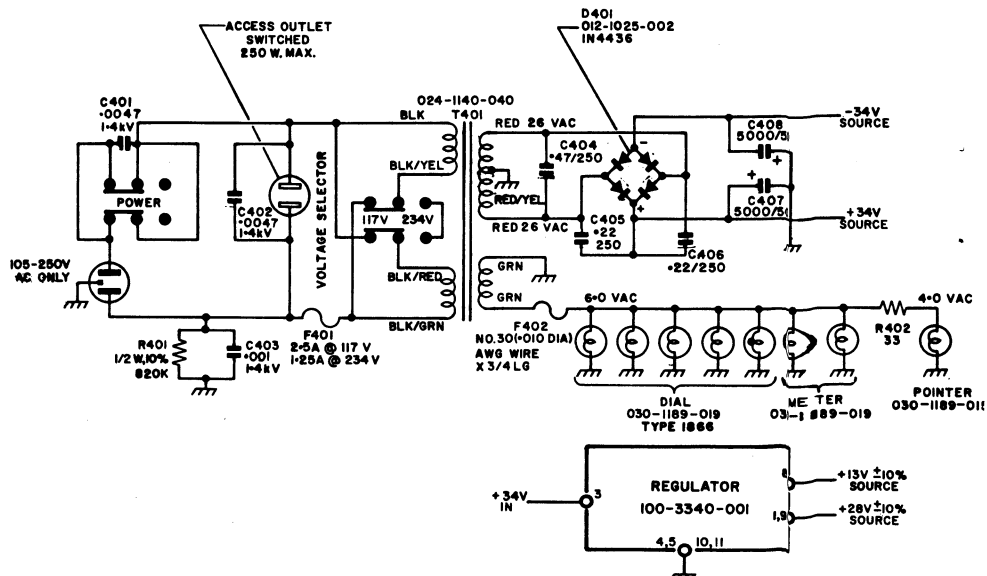

CIRCUIT DIAGRAM R74S

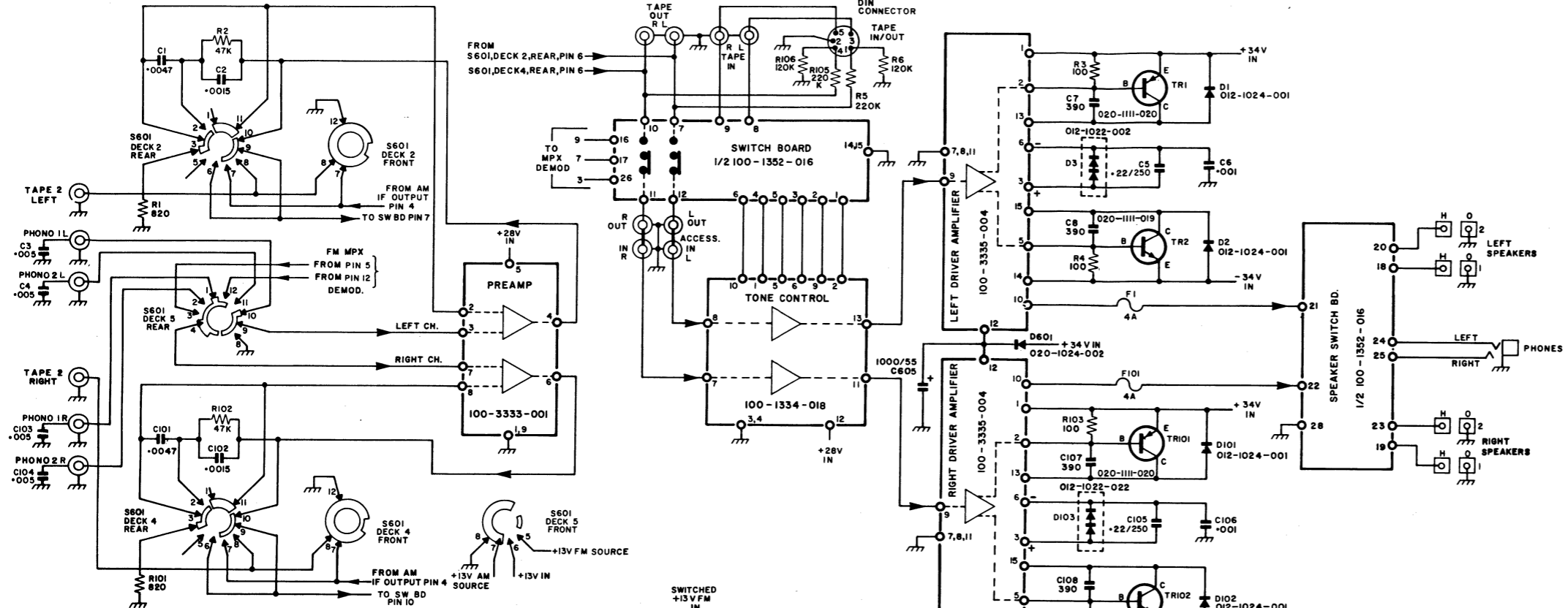

- NOTES:
1. RESISTANCE IN OHMS $\pm 10\%$ 1/4 WATT, CAPACITANCE IN MPD'S, UNLESS OTHERWISE SPECIFIED.
 2. ARROW HEADS INDICATE MAIN SIGNAL PATH.
 3. VOLTAGES ALSO SHOWN ON SUBASSEMBLY DIAGRAMS.
 4. UNLESS OTHERWISE SPECIFIED ALL D.C. VOLTAGES $\pm 15\%$ MEASURED WITH RESPECT TO CHASSIS GROUND, USING 20K Ω /V VOM AT 120 VAC LINE, 300 Ω EXTERNAL ANTENNA. TUNER OFF STATION AND INPUT IN "FM" POSITION.
 5. D.C. OFFSET VOLTAGE WITH NO SIGNAL APPLIED, READ 0 VOLTS ± 25 mV AT SPEAKER 1 OUTPUT TERMINAL. (25mV IS 1.25mA ON TRIPLET 630A 12mA SCALE.)
 6. BIAS CURRENT OF THE POWER AMP P.C. BOARD SHALL BE MEASURED AS FOLLOWS: VOM SET TO MEASURE D.C. CURRENT. MINUS OR COMMON PROBE OF VOM TO PIN 15 AND POSITIVE TO PIN 13 OF DRIVER AMPLIFIER BOARD. READ 1.2mA ON TRIPLET 630A ON 12mA SCALE. USE SAME PROCEDURE FOR OTHER CHANNEL. ALLOW 5 MINUTE WARM-UP BEFORE ADJUSTING BIAS.
 7. FM AGC VOLTAGE (FRONT END A.G.C. TERMINAL) $+10$ TO -2.10 V WITH 0 TO 100 μ V SIGNAL FED INTO 300 Ω EXTERNAL FM ANTENNA. AM A.G.C. VOLTAGE 0 TO -4.7 V WITH 0 TO 5000 μ V SIGNAL FED TO LOOPSTICK WITH ANTENNA COUPLER PER TEST SPEC.
 8. HIGHEST SERIES NUMBERS ARE: R6, R106, R402, R607, C8, C108, C408, C608, D3, D103, D603, D401, F1, F101, F402, L601, S601, T401, TR2, TR102.
 9. THE FOLLOWING CONTROLS IN THE LEFT CHANNEL ARE MECHANICALLY GANGED WITH IDENTICAL CONTROLS IN THE RIGHT CHANNEL. BASS, TREBLE, AND VOLUME CONTROL.
 10. ROTARY SWITCH S601 SHOWN IN MAX COUNTER CLOCKWISE POSITION (POS 1). POSITIONS ARE:

1	PHONO 1
2	PHONO 2
3	FM
4	AM
5	TAPE 2
- (FRONT DECKS SHOWN FROM KNOB END AND REAR DECKS SHOWN FROM END OPPOSITE KNOB)

11. CIRCUIT IS APPLICABLE TO UNITS WITH SERIAL NUMBERS: 041501 - 0415900
USE WITH J FET F.E. R74S-4-C1

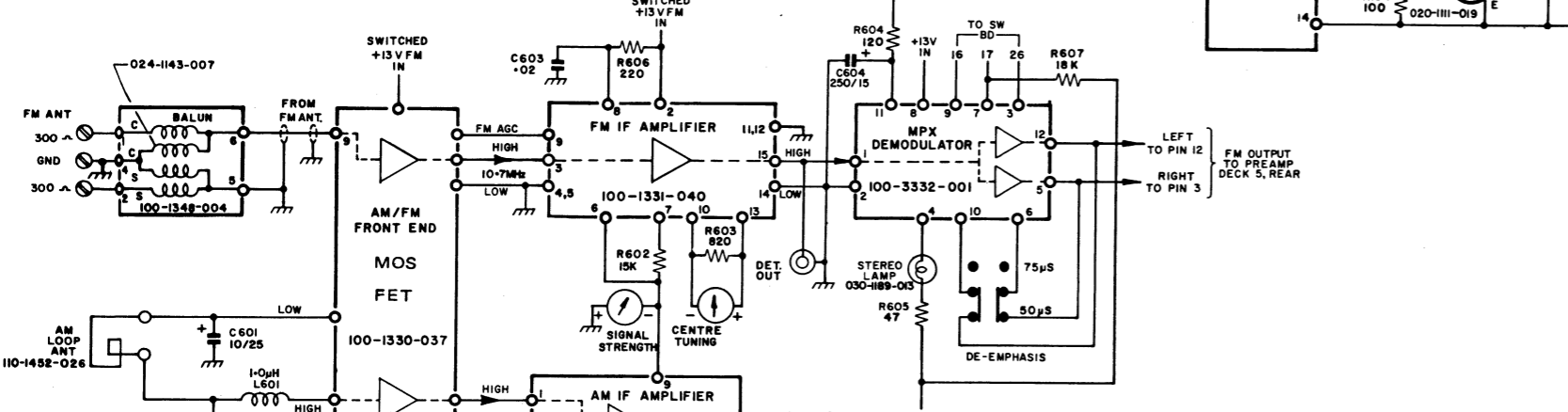

- NOTES:
1. RESISTANCE IN OHMS $\pm 10\%$ 1/4 WATT, CAPACITANCE IN MPD'S, UNLESS OTHERWISE SPECIFIED.
 2. ARROW HEADS INDICATE MAIN SIGNAL PATH.
 3. VOLTAGES ALSO SHOWN ON SUBASSEMBLY DIAGRAMS.
 4. UNLESS OTHERWISE SPECIFIED ALL D.C. VOLTAGES $\pm 15\%$ MEASURED WITH RESPECT TO CHASSIS GROUND, USING 20K Ω /V VOM AT 120 VAC LINE, 300 Ω EXTERNAL ANTENNA. TUNER OFF STATION AND INPUT IN "FM" POSITION.
 5. D.C. OFFSET VOLTAGE WITH NO SIGNAL APPLIED, READ 0 VOLTS ± 25 mV AT SPEAKER 1 OUTPUT TERMINAL. (25mV IS 1.25mA ON TRIPLET 630A 12mA SCALE)
 6. BIAS CURRENT OF THE POWER AMP P.C. BOARD SHALL BE MEASURED AS FOLLOWS: VOM SET TO MEASURE D.C. CURRENT. MINUS OR COMMON PROBE OF VOM TO PIN 15 AND POSITIVE TO PIN 13 OF DRIVER AMPLIFIER BOARD. READ 1.2mA ON TRIPLET 630A ON 12mA SCALE. USE SAME PROCEDURE FOR OTHER CHANNEL. ALLOW 5 MINUTE WARM-UP BEFORE ADJUSTING BIAS.
 7. FM AGC VOLTAGE (FRONT END A.G.C. TERMINAL) $+10$ TO -2.10 V WITH 0 TO 100 μ V SIGNAL FED INTO 300 Ω EXTERNAL FM ANTENNA. AM A.G.C. VOLTAGE 0 TO -4.7 V WITH 0 TO 5000 μ V SIGNAL FED TO LOOPSTICK WITH ANTENNA COUPLER PER TEST SPEC.
 8. HIGHEST SERIES NUMBERS ARE: R6, R106, R402, R607, C8, C106, C408, C608, D3, D103, D603, D401, F1, F101, F402, L601, S601, T401, TR2, TR102.
 9. THE FOLLOWING CONTROLS IN THE LEFT CHANNEL ARE MECHANICALLY GANGED WITH IDENTICAL CONTROLS IN THE RIGHT CHANNEL. BASS, TREBLE AND VOLUME CONTROL.
 10. ROTARY SWITCH S601 SHOWN IN MAX COUNTER CLOCKWISE POSITION (POS 1). POSITIONS ARE:

1	PHONO 1
2	PHONO 2
3	FM
4	AM
5	TAPE 2
- (FRONT DECKS SHOWN FROM KNOB END AND REAR DECKS SHOWN FROM END OPPOSITE KNOB)

11. CIRCUIT IS APPLICABLE TO UNITS WITH SERIAL NUMBERS: 0415501 - 0421000
USE WITH MOS FET F.E. R74S-4-C11

FOR USE WITH QUAD VOLTAGE TRANSFORMER ONLY. SEE NOTE 11.

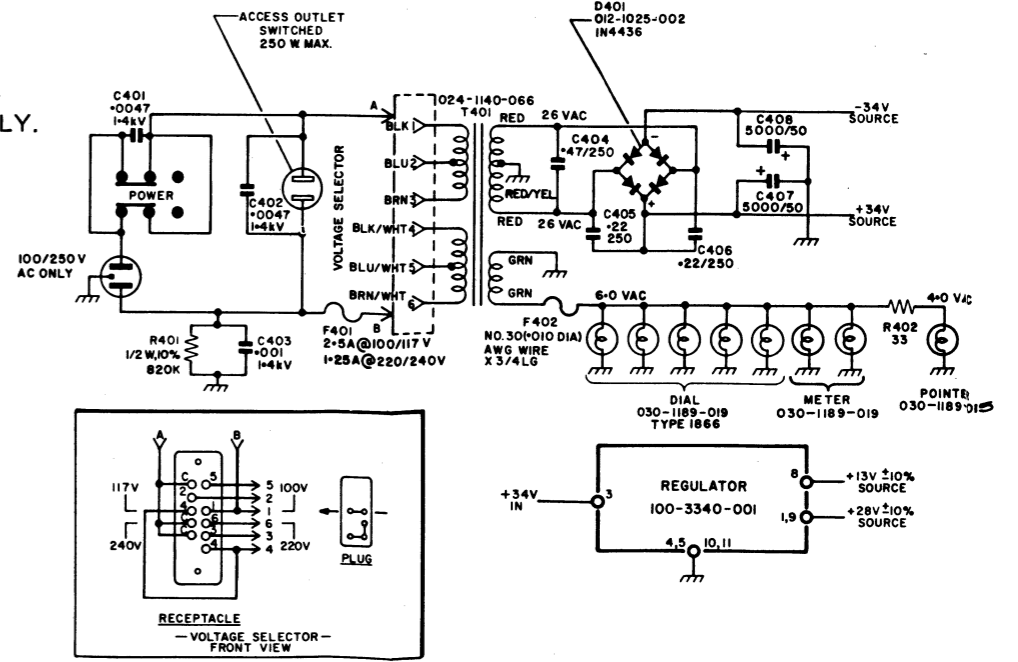
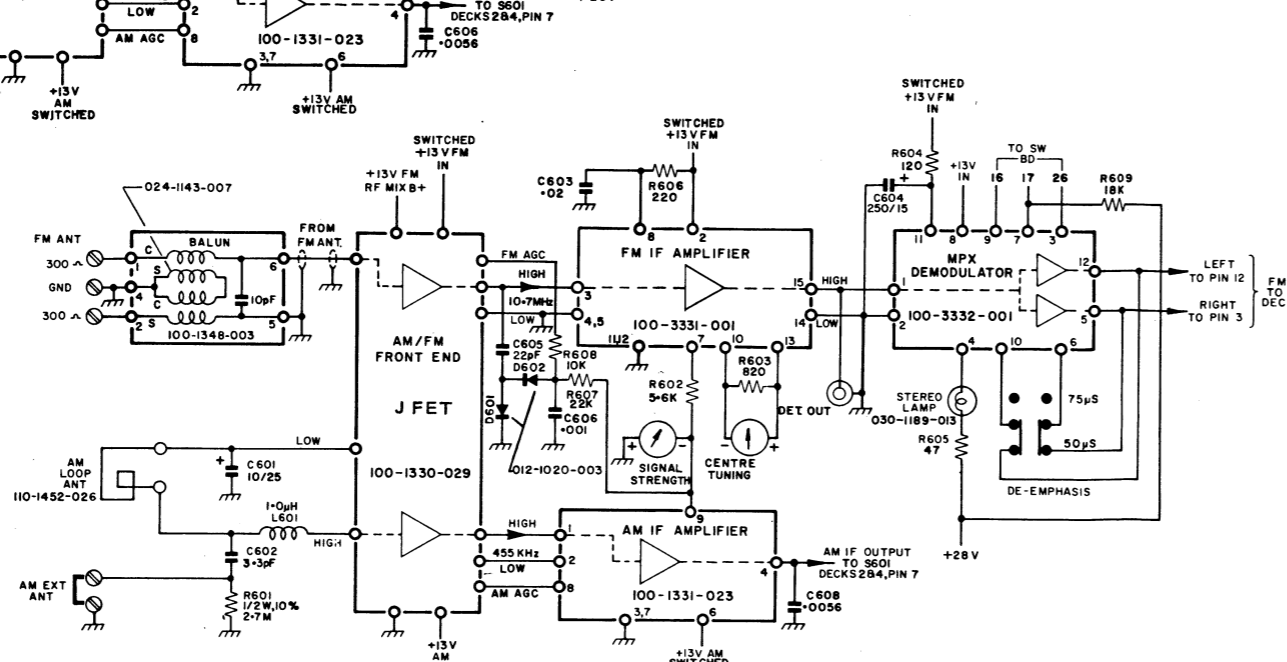

NOTES

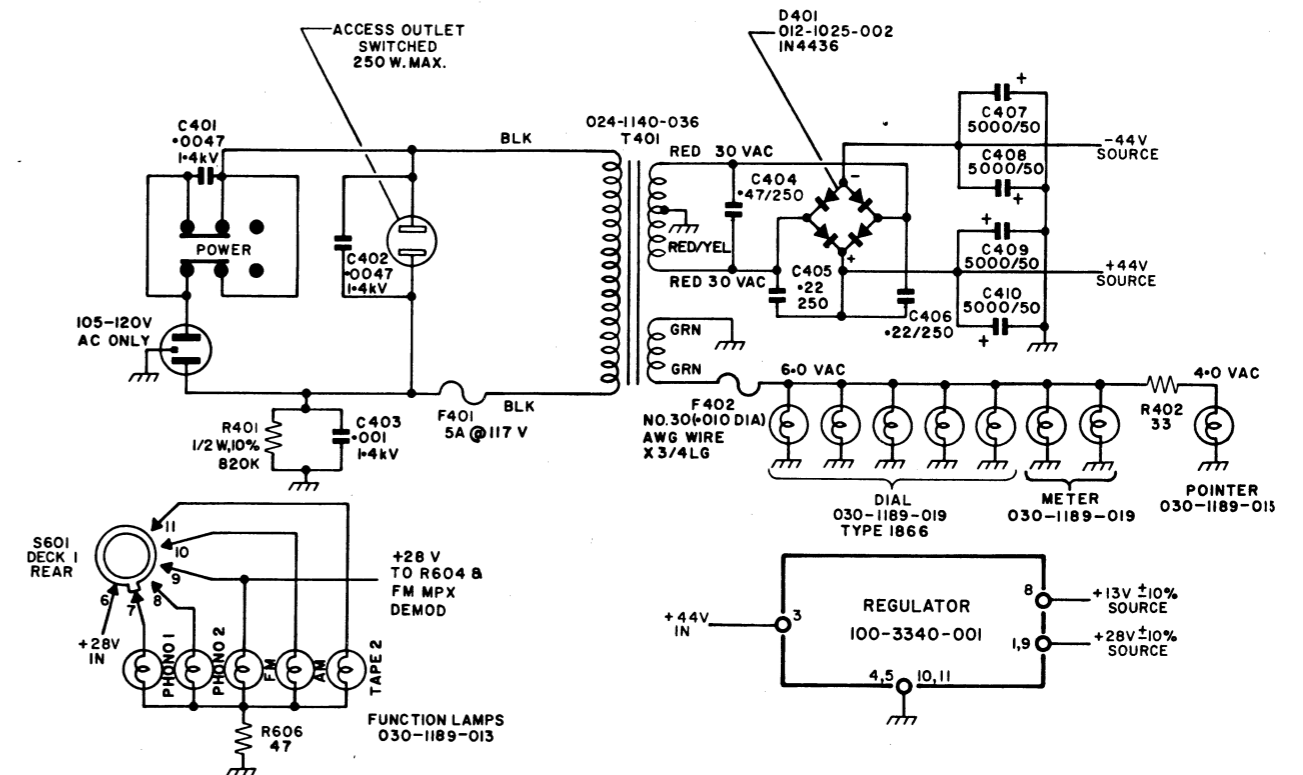

R77-1-C11

NOTES:

1. RESISTANCE IN OHMS $\pm 10\%$ 1/4 WATT, CAPACITANCE IN MFD'S, UNLESS OTHERWISE SPECIFIED.
2. ARROW HEADS INDICATE MAIN SIGNAL PATH.
3. VOLTAGES ALSO SHOWN ON SUBASSEMBLY DIAGRAMS.
4. UNLESS OTHERWISE SPECIFIED, ALL D.C. VOLTAGES $\pm 15\%$ MEASURED WITH RESPECT TO CHASSIS GROUND, USING 20K Ω /V VOM AT 120 VAC LINE, 300 μ A EXTERNAL ANTENNA, TUNER OFF STATION AND INPUT IN "FM" POSITION.
5. D.C. OFFSET VOLTAGE
WITH NO SIGNAL APPLIED, READ 0 VOLTS ± 25 mV AT SPEAKER 1 OUTPUT TERMINAL. (25mV IS 1.25mA ON TRIPLETT 630A 12mA SCALE)
6. BIAS CURRENT OF THE POWER AMP P.C. BOARD SHALL BE MEASURED AS FOLLOWS:
VOM SET TO MEASURE D.C. CURRENT, MINUS OR COMMON PROBE OF VOM TO PIN 15 AND POSITIVE TO PIN 13 OF DRIVER AMPLIFIER BOARD. READ 1.2mA ON TRIPLETT 630A ON 12mA SCALE. USE SAME PROCEDURE FOR OTHER CHANNEL.
ALLOW 5 MINUTE WARM-UP BEFORE ADJUSTING BIAS.
7. FM AGC VOLTAGE (FRONT END A.G.C. TERMINAL) $+10$ TO -2.10 V WITH 0 TO 100 μ V SIGNAL FED INTO 300 μ A EXTERNAL FM ANTENNA. AM A.G.C. VOLTAGE 0 TO -4.7 V WITH 0 TO 5000 μ V SIGNAL FED TO LOOPSTICK WITH ANTENNA COUPLER PER TEST SPEC.
8. HIGHEST SERIES NUMBERS ARE: R6, R106, R402, R608, C6, C106, C410, C606, D3, D103, D601, D401, F1, F101, F402, L601, S601, T401, TR2, TR102.
9. THE FOLLOWING CONTROLS IN THE LEFT CHANNEL ARE MECHANICALLY GANGED WITH IDENTICAL CONTROLS IN THE RIGHT CHANNEL. BASS, TREBLE AND VOLUME CONTROL.
10. ROTARY SWITCH S601 SHOWN IN MAX COUNTER CLOCKWISE POSITION (POS 1).
POSITIONS ARE:
1 PHONO 1
2 PHONO 2
3 FM
4 AM
5 TAPE 2

(FRONT DECKS SHOWN FROM KNOB END AND REAR DECKS SHOWN FROM END OPPOSITE KNOB)
11. CIRCUIT IS APPLICABLE TO UNITS WITH SERIAL NUMBERS:
0402001 - 0404150

FOR USE WITH
SINGLE VOLTAGE
TRANSFORMER ONLY.
SEE NOTE 11.

CIRCUIT DIAGRAM R77S AND R75S

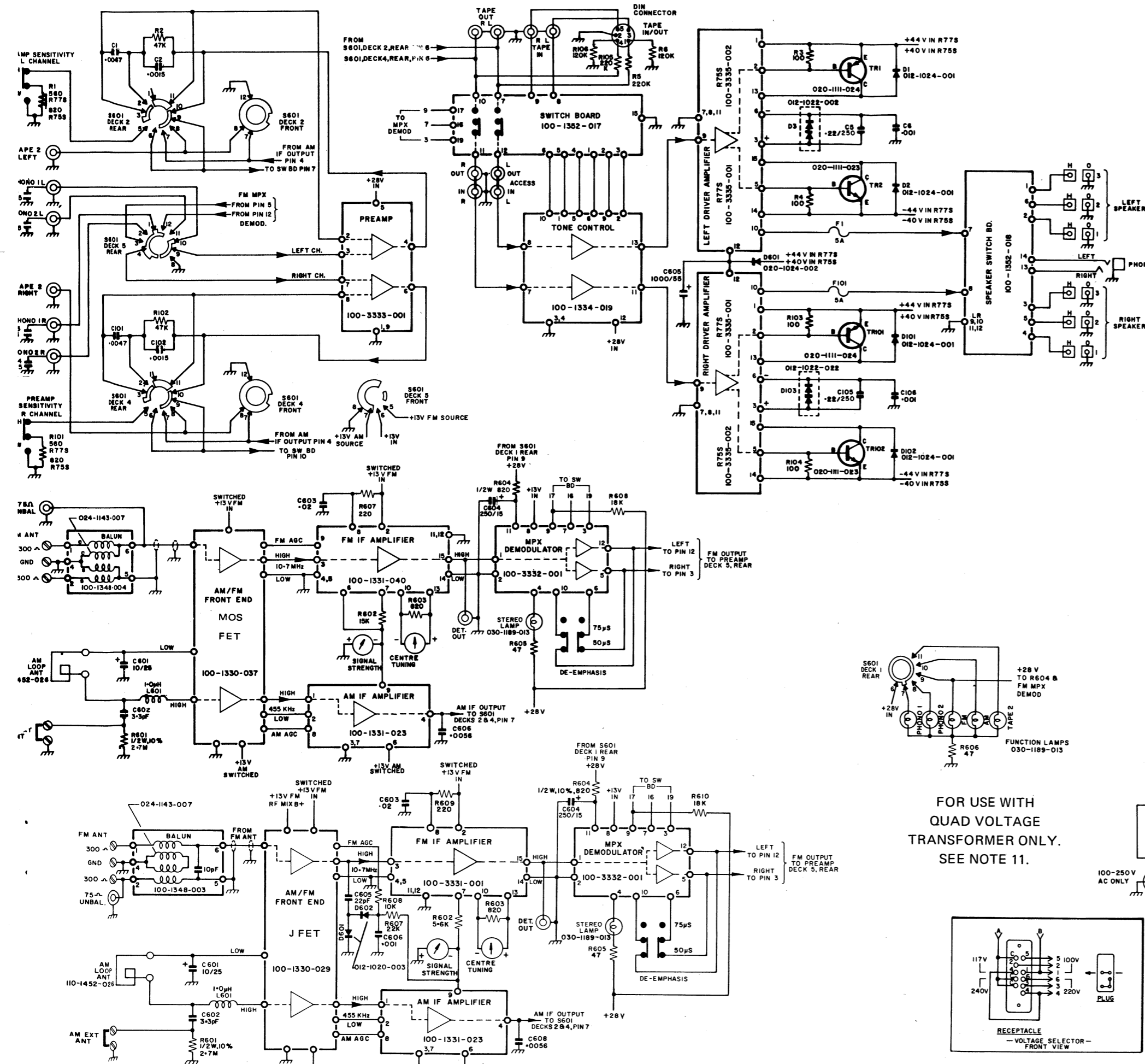

- NOTES:
- RESISTANCE IN OHMS $\pm 10\%$ 1/4 WATT, CAPACITANCE IN MFD'S, UNLESS OTHERWISE SPECIFIED.
 - ARROW HEADS INDICATE MAIN SIGNAL PATH.
 - VOLTAGES ALSO SHOWN ON SUBASSEMBLY DIAGRAMS.
 - UNLESS OTHERWISE SPECIFIED, ALL D.C. VOLTAGES $\pm 1\%$ MEASURED WITH RESPECT TO CHASSIS GROUND, USING 20K Ω /V VOM AT 120 VAC LINE, 300 μ A EXTERNAL ANTENNA. TUNER OFF STATION AND INPUT IN "FM" POSITION.
 - D.C. OFFSET VOLTAGE WITH NO SIGNAL APPLIED, READ 0 VOLTS ± 25 mV AT SPEAKER 1 OUTPUT TERMINAL. (25mV IS 1.25mA ON TRIPLETT 630A 12mA SCALE)
 - BIAS CURRENT OF THE POWER AMP P.C. BOARD SHALL BE MEASURED AS FOLLOWS: VOM SET TO MEASURE D.C. CURRENT, MINUS OR COMMON PROBE OF VOM TO PIN 15 AND POSITIVE TO PIN 13 OF DRIVER AMPLIFIER BOARD. READ 1.2mA ON TRIPLETT 630A ON 12mA SCALE. USE SAME PROCEDURE FOR OTHER CHANNEL. ALLOW 5 MINUTE WARM-UP BEFORE ADJUSTING BIAS.
 - FM AGC VOLTAGE (FRONT END A.G.C. TERMINAL) ± 1.0 TO -2.10 V WITH 0 TO 100 μ V SIGNAL FED INTO 300 μ A EXTERNAL FM ANTENNA. AM A.G.C. VOLTAGE 0 TO -4.7 V WITH 0 TO 5000 μ V SIGNAL FED TO LOOPSTICK WITH ANTENNA COUPLER PER TEST SPEC.
 - HIGHEST SERIES NUMBERS ARE: R6, R106, R402, R610, C6, C106, C410, C606, D3, D103, D603, D401, F1, F101, F402, L601, S601, T401, TR2, TR102.
 - THE FOLLOWING CONTROLS IN THE LEFT CHANNEL ARE MECHANICALLY GANGED WITH IDENTICAL CONTROLS IN THE RIGHT CHANNEL. BASS, TREBLE AND VOLUME CONTROL.
 - ROTARY SWITCH S601 SHOWN IN MAX COUNTER CLOCKWISE POSITION (POS 1). POSITIONS ARE:

1	PHONO 1
2	PHONO 2
3	FM
4	AM
5	TAPE 2

 (FRONT DECKS SHOWN FROM KNOB END AND REAR DECKS SHOWN FROM END OPPOSITE KNOB)
 - CIRCUIT IS APPLICABLE TO UNITS WITH SERIAL NUMBERS:

0401001 - 0401500	R77S
0406001 - 0408000	R75S

 USE WITH J FET F.E. R77S-4-C1
R75S-4-C1

- NOTES:
- RESISTANCE IN OHMS $\pm 10\%$ 1/4 WATT, CAPACITANCE IN MFD'S, UNLESS OTHERWISE SPECIFIED.
 - ARROW HEADS INDICATE MAIN SIGNAL PATH.
 - VOLTAGES ALSO SHOWN ON SUBASSEMBLY DIAGRAMS.
 - UNLESS OTHERWISE SPECIFIED ALL D.C. VOLTAGES $\pm 1\%$ MEASURED WITH RESPECT TO CHASSIS GROUND, USING 20K Ω /V VOM AT 120 VAC LINE, 300 μ A EXTERNAL ANTENNA. TUNER OFF STATION AND INPUT IN "FM" POSITION.
 - D.C. OFFSET VOLTAGE WITH NO SIGNAL APPLIED, READ 0 VOLTS ± 25 mV AT SPEAKER 1 OUTPUT TERMINAL. (25mV IS 1.25mA ON TRIPLETT 630A 12mA SCALE)
 - BIAS CURRENT OF THE POWER AMP P.C. BOARD SHALL BE MEASURED AS FOLLOWS: VOM SET TO MEASURE D.C. CURRENT, MINUS OR COMMON PROBE OF VOM TO PIN 15 AND POSITIVE TO PIN 13 OF DRIVER AMPLIFIER BOARD. READ 1.2mA ON TRIPLETT 630A ON 12mA SCALE. USE SAME PROCEDURE FOR OTHER CHANNEL. ALLOW 5 MINUTE WARM-UP BEFORE ADJUSTING BIAS.
 - FM AGC VOLTAGE (FRONT END A.G.C. TERMINAL) ± 1.0 TO -2.10 V WITH 0 TO 100 μ V SIGNAL FED INTO 300 μ A EXTERNAL FM ANTENNA. AM A.G.C. VOLTAGE 0 TO -4.7 V WITH 0 TO 5000 μ V SIGNAL FED TO LOOPSTICK WITH ANTENNA COUPLER PER TEST SPEC.
 - HIGHEST SERIES NUMBERS ARE: R6, R106, R402, R608, C6, C106, C410, C606, D3, D103, D601, D401, F1, F101, F402, L601, S601, T401, TR2, TR102.
 - THE FOLLOWING CONTROLS IN THE LEFT CHANNEL ARE MECHANICALLY GANGED WITH IDENTICAL CONTROLS IN THE RIGHT CHANNEL. BASS, TREBLE AND VOLUME CONTROL.
 - ROTARY SWITCH S601 SHOWN IN MAX COUNTER CLOCKWISE POSITION (POS 1). POSITIONS ARE:

1	PHONO 1
2	PHONO 2
3	FM
4	AM
5	TAPE 2

 (FRONT DECKS SHOWN FROM KNOB END AND REAR DECKS SHOWN FROM END OPPOSITE KNOB)
 - CIRCUIT IS APPLICABLE TO UNITS WITH SERIAL NUMBERS:

0401501 - 0406000	R77S
0408001 - 0411000	R75S

 USE WITH MOS FET F.E. R77S-4-C11
R75S-4-C11

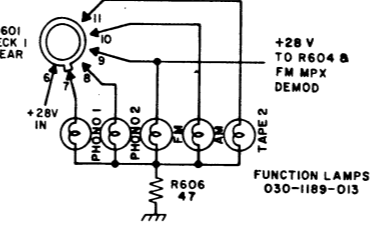

FOR USE WITH QUAD VOLTAGE TRANSFORMER ONLY. SEE NOTE 11.

