

price \$7.00

SERVICE MANUAL
solid state stereo components

T-311S A-236S R-31S R-34S

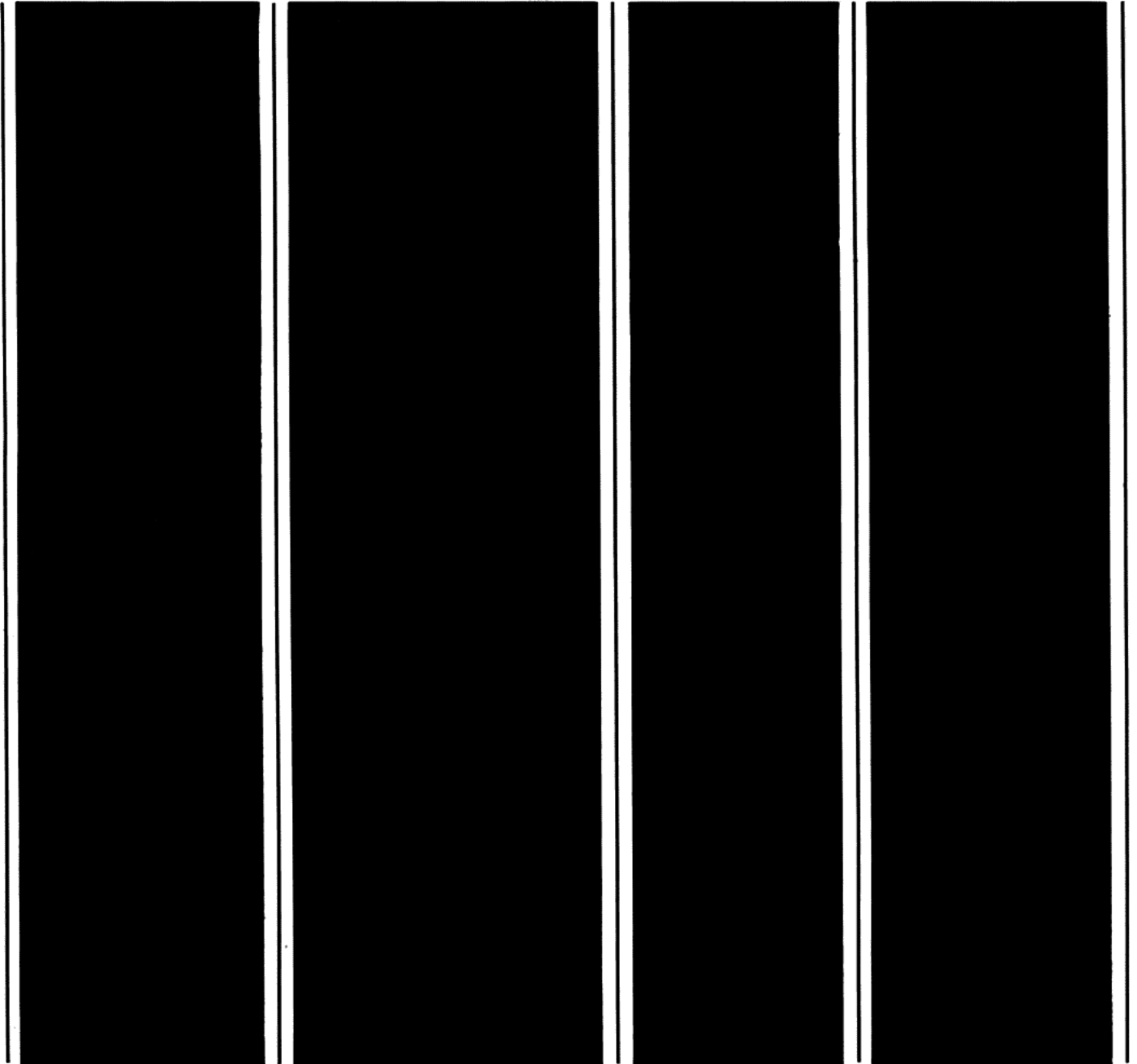

W SCOTT® ...where innovation is a tradition

H. H. SCOTT, INC., 111 Powder Mill Road, Maynard, Massachusetts 01754, Tel. 617 897-8801

TABLE OF CONTENTS

	Page Number
Audio Specifications	1
FM and AM Specifications	2
General Specifications	3
Figure FM-1	4
Test and Alignment	5
Audio Test Procedure	6-9
Tuner Alignment Procedure	10
FM Alignment Procedure	11
Multiplex Alignment Procedure	12
Front End Circuit Diagram	13
Dial Cord Stringing Diagram	14
Dial Cord Stringing Instructions	15
Notes	16
T-311S Circuit Diagram	17-18
A-236S Circuit Diagram	19-20
R-31S Circuit Diagram	21-22
R-34S Circuit Diagram	23-24
Notes	25

AUDIO SPECIFICATIONS
R-31S, A-236S AND R-34S

Output Power:
 R-31S & A-236S _ 15W
 R-34S _ _ _ _ _ 20W

per channel, min. RMS, at 8 ohms from
 20 Hz to 20 kHz, with no more than
 0.5% total harmonic distortion.

Phono Sensitivity		2.5 mV @ 1 kHz
Aux. Sensitivity		150 mV
Signal - to - noise ratio	Phono	60 dB
	Aux.	70 dB
	Tape Input	70 dB
Frequency Response	Aux.	-3 dB @ 10 Hz & 30 kHz
Maximum Input Signal (IHF)	Phono	28 dB
Phono Input Impedance		47000 ohms
Aux. & Tape Input Impedance		60K - 110K ohms
Tape Input Sensitivity		150 mV
Tape Output Level		150 mV
Damping Factor		35

Controls

Bass Range	@ 100 Hz	+10 dB (+2 dB)
Treble Range	@ 10 kHz	+10 dB (+2 dB)
Loudness Comp.	+7 dB @ 100 Hz	+2 dB
	+2 dB @ 10 kHz	+2 dB
Separation, High Level		50 dB @ 1 kHz
Balance Control Range		60 dB @ 1 kHz
Headphone Output Level		-24 dB (ref. spkr. output)
Headphone Output Impedance		10 - 15 ohms

**FM SPECIFICATIONS
R-31S, R-34S AND T-311S**

Tuning Range		87.5 - 108 MHz
Sensitivity (IHF)		2.5 μ V
Selectivity (alternate chan.)		55 dB
Capture Ratio		2.5 dB
Signal - to - noise ratio	Re: 100% mod.	64 dB
Total Harmonic Distortion	Mono	0.8%
	Stereo	1.0%
Stereo Separation	@ 1 kHz	35 dB
	@ 10 kHz	18 dB
Calibration Accuracy		0.2%
Antenna Input		300 ohm, Bal.
Audio Frequency Response		50 Hz - 12 kHz \pm 2 dB
Image Response		60 dB
Spurious Response		85 dB
Subcarrier Suppression		50 dB
SCA Suppression		55 dB
Muting Sensitivity		4 μ V typ.
Stereo Threshold Sensitivity		7 μ V typ.
Deemphasis		50 & 75 μ S switchable

**AM SPECIFICATIONS
R-31S, R-34S AND T-311S**

Tuning Range		535 - 1605 kHz
AM Sensitivity		150 μ V/m
Image Rejection		45 dB
Total Harmonic Distortion	Re: 60% mod.	2.0% @ 5 mV/m
IF Rejection		30 dB
Selectivity		40 dB
Hum & Noise	Re: 100% mod.	55 dB

GENERAL SPECIFICATIONS

Power Requirement 100, 120, 220 or 240 Volts
50 or 60 Hz

Power Consumption:

R-31S	17W min. 90W max.
A-236S	15W min. 75W max.
R-34S	17W min. 100W max.
T-311S	14 Watts

Dimensions:

R-31S & R-34S	Width	17 7/8 in.	455 mm
	Depth	12 in.	305 mm
	Height	5 1/2 in.	140 mm

T-311S & A-236S	Width	15 5/16 in.	390 mm
	Depth	10 1/4 in.	260 mm
	Height	5 1/2 in.	140 mm

Net Weight:

R-31S	16.5 lbs	7.5 kg
R-34S	17.6 lbs	8.0 kg
A-236S	11.8 lbs	5.4 kg
T-311S	10.0 lbs	4.6 kg

Shipping Weight:

Add approximately 5 lbs (2.3 kg) for standard container and materials.

Where a standard FM antenna matching network is not available for the particular signal generator in use, A suitable network can be assembled on a small phenolic, or plastic board, using the circuit below.

The completed assembly should use short leads for connection to the receiver antenna terminals. Some generator cables may permit the circuit block to be attached directly to the cable terminals.

FIGURE FM-1

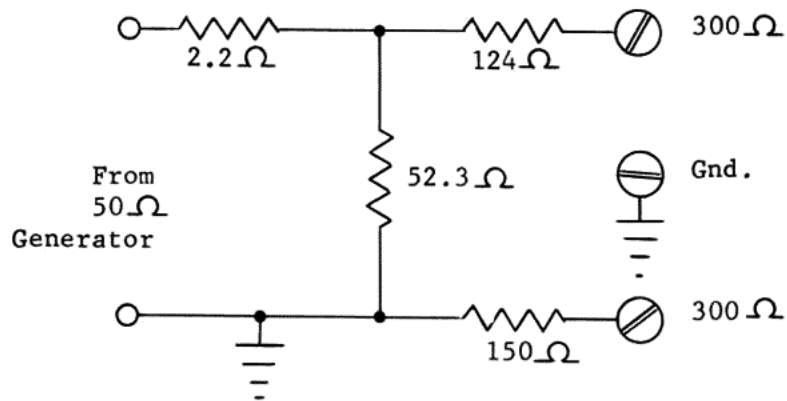

Note: All resistors are 1/2 Watt, carbon composition, selected on a DVM, or Wheatstone bridge.

TEST AND ALIGNMENT PROCEDURES

RECOMMENDED EQUIPMENT

(or equivalent)

1. AC vacuum tube Voltmeter (H.P. 400D)
2. Oscilloscope
3. Volt-Ohm meter (Triplett model 630)
4. Harmonic Distortion meter (H.P. 331A)
5. AM Signal Generator (H.P. 606A)
6. FM Signal Generator (Measurements Corp. model 88)
7. Multiplex Generator (Scott model 830)
8. Audio Oscillator (H.P. 200 CD)
9. Standard AM dummy antenna (200 μ F ceramic or mica capacitor)
10. Standard FM dummy antenna for 300 ohm balanced input (see circuit, Figure FM-1)
11. Suitable alignment tools, cables, etc.
12. Two 8 ohm resistive loads, compensated for L & C (min. 30W)
13. Variable power line transformer (General Radio 5A)
14. Suitable line Voltage and current monitoring meters

Note: Equipment specifications are minimum.

Set controls to following positions for test procedure. Deviate from these settings as instructed in the test procedures. Return to these settings at the beginning of each new test. All tests are to be made with 117V AC line. Unless otherwise specified, supply input to both channels and read both outputs.

Front Panel

Input Selector	Aux
Tone Controls	Flat (12 O'clock)
Loudness	Minimum (full CCW)
Balance	12 O'clock
Speaker #1	On

Note: When troubleshooting defective power circuits, it is sometimes useful to switch a small line voltage lamp in series with equipment under test before applying power. The lamp will limit the current drawn, thus preventing further damage to circuit components.

The variable power line transformer is also useful to determine if additional short circuits exist, if used with a power line current and Volt meter.

AUDIO TEST PROCEDURE

TEST	INPUT	CONTROL SETTINGS	TEST EQUIPMENT	SCALE SETTINGS	MEASURE AT		READINGS	TOL.
					POSITIVE PROBE	NEGATIVE PROBE		
PNP Output transistor Q301 & Q303	None Unit "OFF"		Triplet 630A •	Ohms X 1000	+ Filter cap	P307 P309	12K	+1K
NPN Output transistor	None Unit "OFF"		Triplet 630A	Ohms X 1000	P307 P309	- Filter cap	3K	+1K
B+ Supply	None Unit "On"	Volume "Minimum" Selector "FM"	Triplet 630A	Volts 60 DC	+ Filter cap	Chassis	+25V DC (R-34S) +23V DC (R-31S & A-236) +19V DC (T-311S)	+15%
B- Supply	None Unit "On"	Volume "Minimum" Selector "FM"	Triplet 630A	Volts 60 DC	Chassis	- Filter cap	-25V DC (R-34S) -23V DC (R-31S & A-236) N. A. (T-311S)	+15%
Regulated B+ Voltage	None Unit "On"	Volume "Minimum" Selector "FM"	Triplet 630A	Volts 60 DC	P601 Regulator/ Supply Board	Chassis	+13V DC	+10%
Output Offset Voltage	None Unit "On"	Volume "Minimum" Selector "Aux."	Triplet 630A	12mA DC	Speaker #1 "H"	Speaker #1 "O"	+4mA	Max.
			DC Milli- Voltmeter	100mV	Speaker #1 "H"	Speaker #1 "O"	+100mV	Max.
Bias Check	None Unit "On"	None, if necessary, adj. padd- ing resis- tor across R308 L. Ch. R339 R. Ch.	Triplet 630A	12mA DC only	"E" of Q301 "E" of Q303	"C" of Q302 "C" of Q304	Adjust pad for 0.2mA DC nominal	+100% -0

AUDIO TEST PROCEDURE

TEST	INPUT	CONTROL SETTINGS	TEST EQUIPMENT	SCALE SETTINGS	MEASURE AT		READINGS	TOL.
					POSITIVE PROBE	NEGATIVE PROBE		
Audio Level 8 ohm	1000 Hz Aux. 1	Selector "Aux." Mono Switch "In" Volume "Maximum"	AC VTVM Scope	30V 5V/DIV	Speaker #1 "H" 8 ohm load high 15W (A-236 & R-31) 20W (R-34)	Speaker #1 "O" 8 ohm load low	Adjust input for 10.96V (A-236 & R-31) 12.65V (R-34) at output. Input level should be .15V. Output not clipped with 117V AC line.	
Tape Inputs	Tape In 1000 Hz	Tape Monitor Switch "Monitor"	AC VTVM	30V	Speaker #1 "H" 8 ohm load high	Speaker #1 "O" 8 ohm load low	Output of 10.96V (A-236 & R-31) 12.65V (R-34) with input of .15V ± 1 dB	
Tape Monitor Output	Aux.	Selector "Aux." Volume "Minimum"	AC VTVM	1V	Tape Out	Ground	Output of 0.15V with input of 0.15V	
Speaker 2	Aux. 1000 Hz	Selector "Aux." Mono Switch "Mono" Volume "Maximum" Spkr. 2 On	AC VTVM	30V	Speaker #2 "H" 8 ohm load high	Speaker #2 "O" 8 ohm load low	Output 0 dB 10.96V (A-236 & R-31) 12.65V (R-34) Input of .15V ± 1 dB	
Frequency Response Power Amp & Tone Control	Aux. (20 Hz to 20 kHz)	Tone Control "Flat" Volume "Maximum" Adjust balance for center	AC VTVM	1V	Speaker #1 "H" 8 ohm load high	Speaker #1 "O" 8 ohm load low	Adjust input for 0 dB (.775V) out. (3 dB down points should be below 10 Hz and above 30 kHz)	± 1 dB

AUDIO TEST PROCEDURE

TEST	INPUT	CONTROL SETTINGS	TEST EQUIPMENT	SCALE SETTINGS	MEASURE AT		READINGS	TOL.
					POSITIVE PROBE	NEGATIVE PROBE		
Frequency Response Phono (RIAA)	Phono 1000 Hz	Selector "Phono" Keep setting listed above	AC VTVM	1V	Speaker #1 "H" 8 ohm load high	Speaker #1 "O" 8 ohm load low	Adjust input for 0 dB (.775V) out Note: 100 Hz +12.5 dB 10 kHz -13.0 dB	± 2 dB
Tone Control Response	Aux. 1000 Hz	Selector "Aux." Mode Switch "Mono" Tone Control "Flat"	AC VTVM	3V	Speaker #1 "H" 8 ohm load high	Speaker #1 "O" 8 ohm load low	Adjust output for -10 dB Note: 100 Hz Bass boost +10 dB Bass cut -10 dB 10 kHz Treble boost +10 dB Treble cut -10 dB	± 2 dB ± 2 dB ± 2 dB
Loudness Compensation	Aux. 1000 Hz	Selector "Aux." Tone Control "Flat" Volume "11 O'clock" Loudness Sw. "On"	AC VTVM	3V	Speaker #1 "H" 8 ohm load high	Speaker #1 "O" 8 ohm load low	Adjust output for -10 dB. Frequency, 10 kHz; Note 3 dB increase. Frequency to 100 Hz; Note 7 dB increase	-1 dB +2 dB ± 3 dB
Crosstalk	Aux. Left Channel	Selector "Aux." Tone Control "Flat" Comp. Sw. "Off" Volume "Maximum" Mode Switch "Stereo"	AC VTVM	3V	Speaker #1 "H" 8 ohm load high	Speaker #1 "O" 8 ohm load low	Set output for 0 dB Read right channel output 30 dB down	Min.

AUDIO TEST PROCEDURE

TEST	INPUT	CONTROL SETTINGS	TEST EQUIPMENT	SCALE SETTINGS	MEASURE AT		READINGS	TOL.
					POSITIVE PROBE	NEGATIVE PROBE		
Balance Control	Aux. Left Channel 1000 Hz	Selector "Aux." Tone Control "Flat" Comp. Sw. "Off" Volume "Maximum" Mode Switch "Mono" Balance CCW	AC VTVM	3V	Speaker #1 "H" 8 ohm load high	Speaker #1 "O" 8 ohm load low	Set output for 0 dB Note 45 dB drop in output, right chan.	+2 dB
		Balance CW			"	"	Note 45 dB drop in output, left chan.	+2 dB
Harmonic* Distortion	Aux. 20 Hz 1000 Hz 20,000 Hz	Selector "Aux." Mode Switch "Mono" Balance "Center" Volume "Maximum"	AC VTVM Harmonic Distortion Analyzer	30V	Speaker #1 "H" 8 ohm load high	Speaker #1 "O" 8 ohm load low	Set output to 10.96V (A-236 & R-31) 12.65V (R-34) Distortion: 0.5% @ 20 Hz 1000 Hz 20,000 Hz	
*Note: Power line Voltage 117 VAC < 2.0% line THD.								
Damping Factor	Aux. 1000 Hz	Selector "Aux." Mode Switch "Mono" Balance "Center" Volume "Maximum"	AC VTVM	30V	Speaker #1 "H" 8 ohm load high	Speaker #1 "O" 8 ohm load low	Set output to 10.96V (A-236 & R-31) 12.65V (R-34) Remove & note increase in level Max. 0.5 dB	

TUNER ALIGNMENT PROCEDURE

Set dial pointer for zero logging with tuning capacitor fully closed.

AM ALIGNMENT

STEP	ANTENNA	SIGNAL GENERATOR COUPLING	SIGNAL GENERATOR FREQUENCY	INPUT SELECTOR SWITCH	DIAL SETTING	OUTPUT METER	ADJUST	REMARKS
1.	Direct ext. antenna term. thru 200 pF dummy antenna	External ant. terminal, keep signal level low	455 kHz 60% mod. 400 Hz	AM	600 kHz Off station	VTVM @ Tape output	T102 on IF Yellow & Black	Generator modulation 30% Output 1000 μ V Audio output 25-50 mV
2.	Same as above	Same as above	600 kHz	Same	Same	Same	AM-0 (Red)	Adjust for calibration
3.	Same as above	Same as above	1400 kHz	Same	1400 kHz Off stn.	Same	Osc. trimmer	Rear section of Front End Adjust for calibration
4.	Same as above	Same as above	Same as above	Same	Same	Same	Ant. trimmer	R.F. trimmer, Front End
5.	Same as above	Same as above	600 kHz	Same	600 kHz	Same	Ant. slider under brkt.	Antenna- soften wax, adjust slider, adjust for maximum
6.	Repeat steps 2, 3, 4 & 5 for maximum.							
7.	Same as step 1	300 μ V output	1400 kHz	AM	1400 kHz	0.15V	Check specification	Signal strength meter 2.5-5 Audio output 0.15V

FM ALIGNMENT

STEP	ANTENNA	SIGNAL GENERATOR COUPLING	SIGNAL GENERATOR FREQUENCY	INPUT SELECTOR SWITCH	DIAL SETTING	OUTPUT METER	ADJUST	REMARKS
1.	Dummy antenna Figure FM-1	External 300 ohm term. Use low signal level	10.7 MHz 100% mod.	FM	Off Station	VTVM @ Tape Output	Front End IF	Adjust for maximum signal strength meter indication
2.	Same as above	Same as above	90 MHz	Same	90 MHz	Same	Front End LO	Adjust for maximum output
3.	Same as above	Same as above	Same	Same	Same	Same	Front End LA LR LR	Adjust for maximum Keep signal level low
4.	Same as above	No Output	Same	Same	Off Station Use noise only	Same	Detector T101 Blue	R-34 Use center tune meter R-31 & T-311 Use DC VTVM connected, negative to Gnd., positive to P116. Adjust for zero DC Volts
5.	Same as above	External 300 ohm term. Use low signal level	90 MHz	FM	90 MHz	VTVM @ Tape Output	T101 Red	Adjust for maximum output and minimum distortion
6.	Same as above	Same as above	106 MHz	Same	106 MHz	Same	TCO	Tune for center tune
7.	Same as above	Same as above	106 MHz	Same	106 MHz	Same	TCA, TCR & TCR	Adjust for maximum, keep input level low for noisy signal
8.	Repeat steps 2, 3, 6 & 7 until no further improvement is noted. Check specification.							

DIAL CORD DIAGRAM

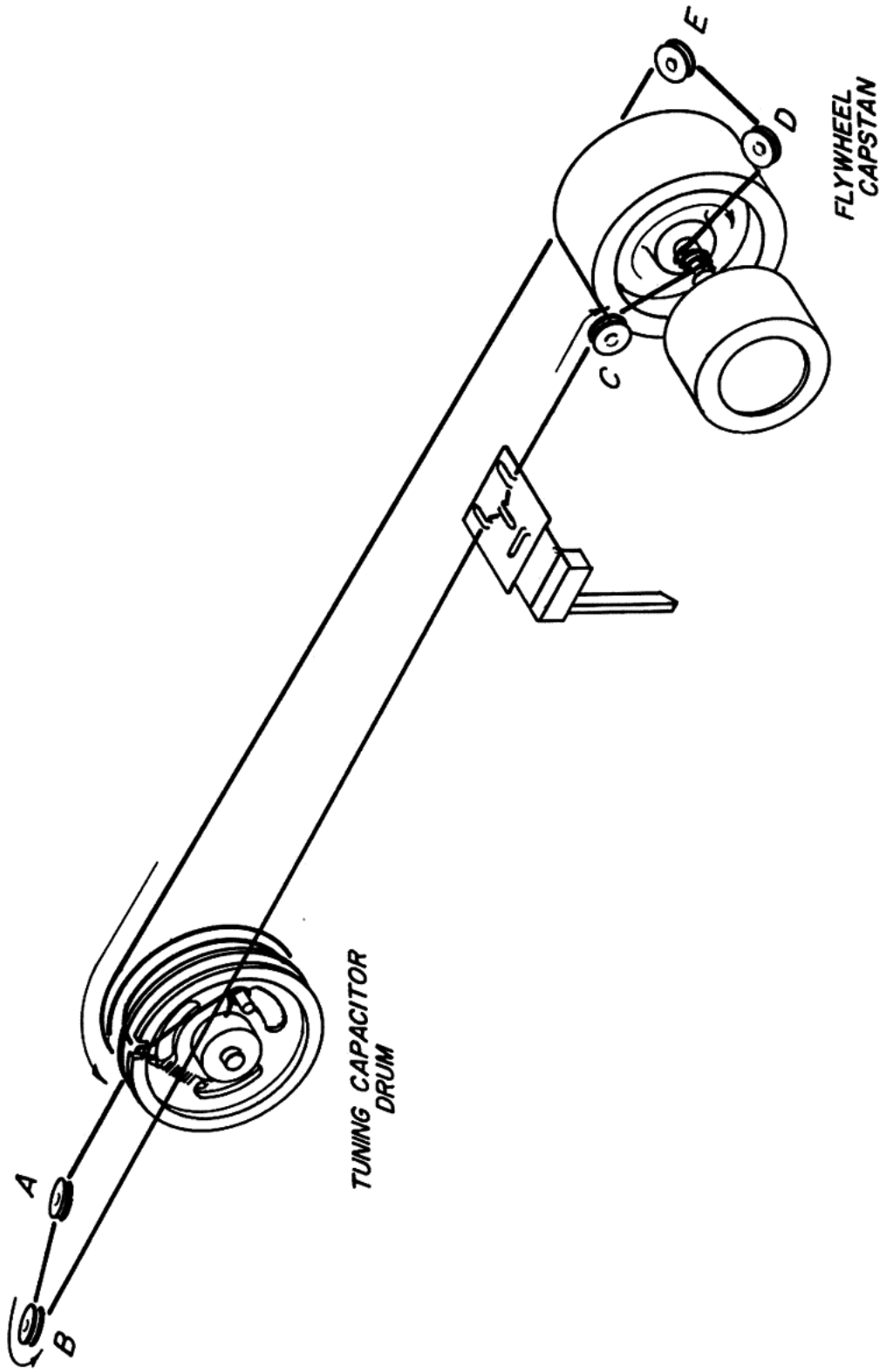

DIAL CORD STRINGING INSTRUCTIONS

1. Set tuning capacitor to open. (plates out)
2. Tie end of dial cord around peg on tuning capacitor drum.
3. Install cord around pulleys "A", "B" and "C".
4. Install cord over the top of flywheel capstan, winding the cord clockwise, 3 turns, exiting on the inside top.
5. Install the cord around pulleys "D" and "E".
6. Wind cord counter clockwise around tuning drum, 2 turns, from back to front, exiting at notch in tuning drum.
7. Tie spring to end of cord approx. 1/4 inch outside of notch for suitable tension and install free end of spring in slot as shown.
8. Position pointer at 100 on logging scale.
9. Secure knots at both ends of cord with drops of glue, taking care not to get glue on other places.

1115 CIRCUIT DIAGRAM

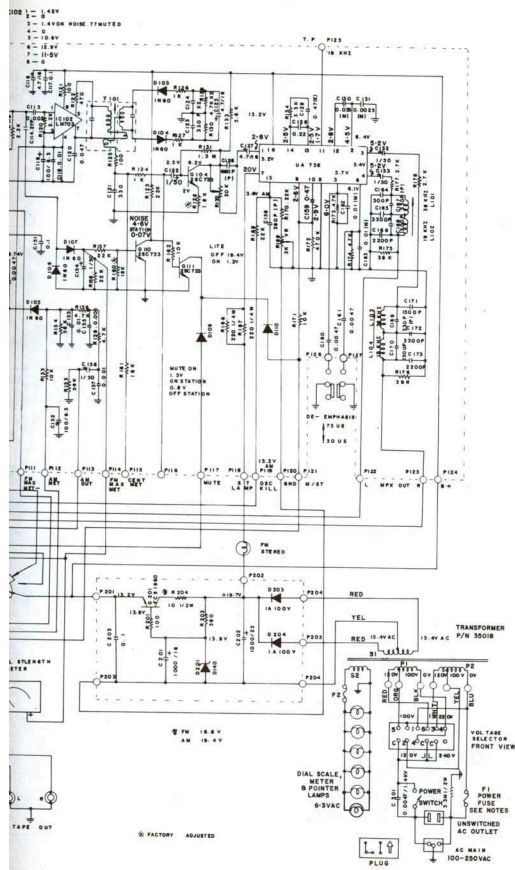

A-236S CIRC

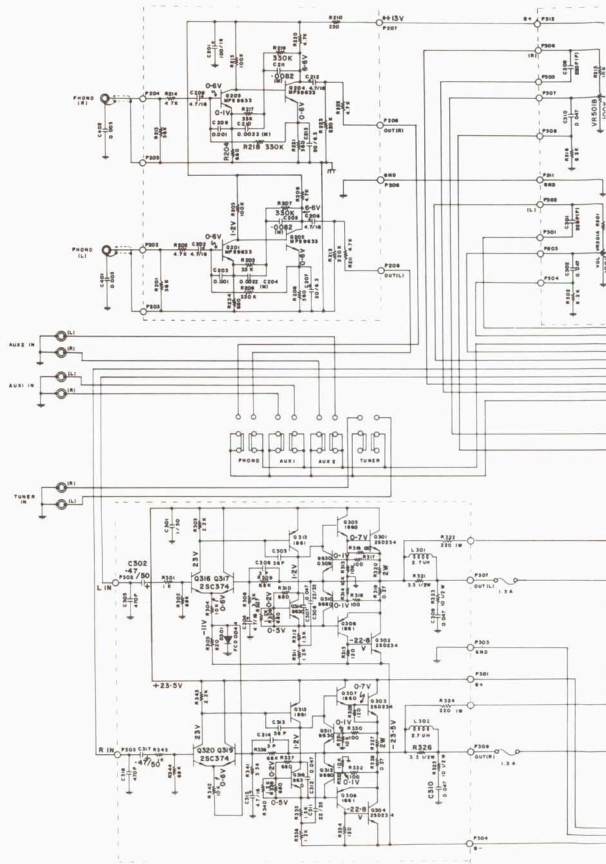

R-31S AND R-34S NOTES

Unless otherwise specified, all capacitors are in microfarads, all resistors are in ohms, $\frac{1}{2}$ Watt, 10% (or less) tolerance, and all voltages $\pm 10\%$, measured with 20,000 ohm per Volt VOM. 117V power line.

C306 and C314 not used in some units.

Front ends marked FL-311 or FL-315 may be used in some production.

LAMPS

Pointer	6.3V	40 mA
Function	12V	40 mA
Stereo	12V	80 mA
Dial	6.3V	220 mA

FUSES

Speaker	1.5A	Fast-Blo (R-34; 2A)
Power	1.5A	Slo-Blo @ 100-125V
	0.7A	Slo-Blo @ 220-240V
Dial	Suitable length of #30 Awg. copper (0.010 inch dia.)	

Switch (S-1) Replace only with original approved type.