

HITACHI

SERVICE MANUAL

TK

No. 1918E

CP-10EX

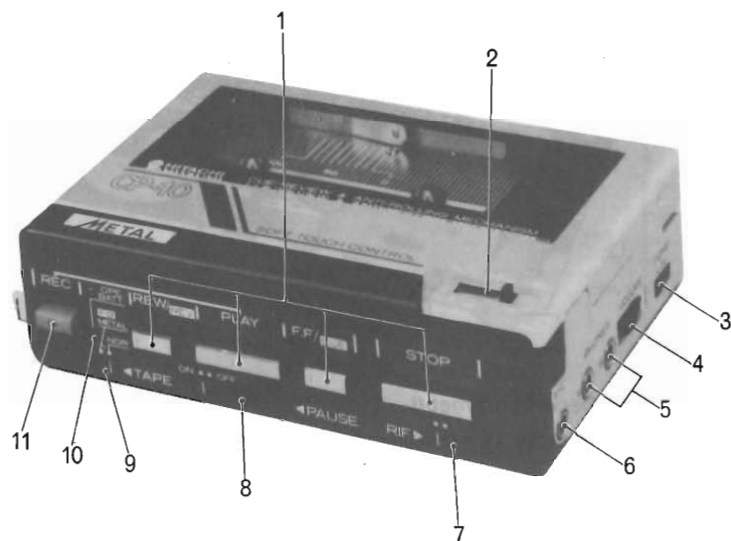

CONTENTS

Disassembly.....	2
Block diagram	3
Adjustment	3
Erase head replacement	4
Schematic diagram	5
Circuit board diagram.....	7
Exploded view	9
Lubrication.....	10
Replacement parts list.....	11
Inspection of mechanism.....	13

KEY TO ILLUSTRATIONS

- | | |
|----------------------|---------------------------------|
| 1. OPERATION BUTTONS | 7. RIF SWITCH |
| 2. TAPE COUNTER | 8. PAUSE SWITCH |
| 3. TONE SWITCH | 9. TAPE SELECT SWITCH |
| 4. VOLUME CONTROL | 10. OPERATION/BATTERY INDICATOR |
| 5. HEADPHONE JACKS | 11. RECORD BUTTON |
| 6. MICROPHONE JACK | |

SPECIFICATIONS

Tape :	Cassette tape (C-30, 60, 90)	Input Sensitivity and Impedance :	Microphone : 0.4 mV, 3.3k ohms
Track System :	4 track 2 channel	Output Impedance :	Headphone : 8 ohms to 300 ohms
Tape Speed :	4.75 cm/s	Wow and Flutter :	0.35% (WRMS)
Recording System :	AC Bias, 57 kHz	Fast Forward or Rewinding Time :	150 sec. (Using C-60)
Erasing System :	AC erase	Semiconductors :	ICs : 4
Frequency Response :	Metal : 50 to 14,000 Hz Normal : 50 to 12,000 Hz		Transistors : 9
S/N (Signal to Noise Ratio) :	50 dB		Diodes : 2
Distortion :	3%		LED : 1
Motor :	DC micromotor	Power Output :	30 mW + 30 mW (T.H.D. 10%)
Cross Talk :	50 dB (Between tracks) 30 dB (Between channels)	Power Supply :	DC 3V ("AA" cell × 2 or IEC R6 × 2)
Erase Ratio :	50 dB	Power Consumption :	160 mA (with no signal)
		Dimensions :	120(W) × 33.5(H) × 80(D) mm
		Weight :	320 g (with batteries)

SPECIFICATIONS AND PARTS ARE SUBJECT TO CHANGE FOR IMPROVEMENT

STEREO CASSETTE RECORDER

April 1983

TOKAI WORKS

DISASSEMBLY

1. Cassette lid

Remove (A) (three) screws.

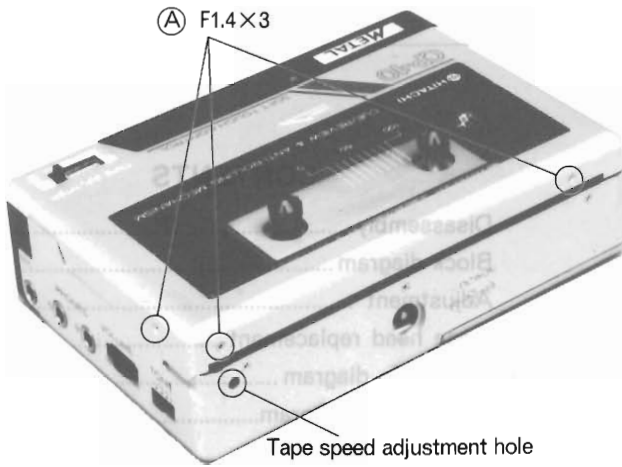

2. Escutcheon

Remove (B) (five) screws.

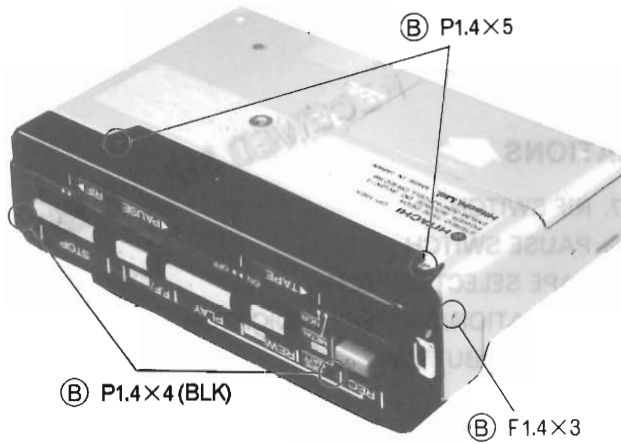

4. Main PC board

Remove (D) (two) screws.

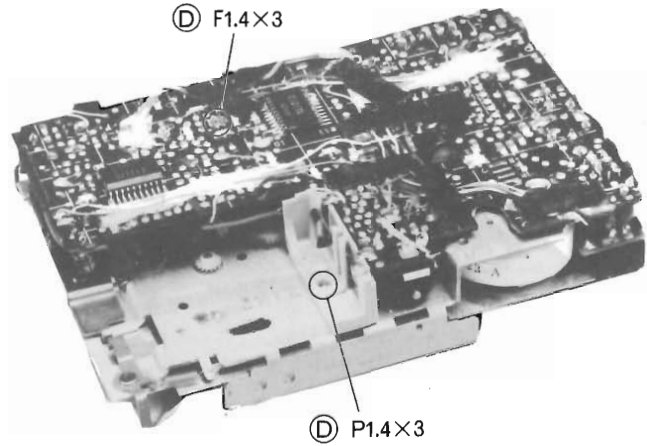

5. Decoration metal

Remove (E) (two) screws.

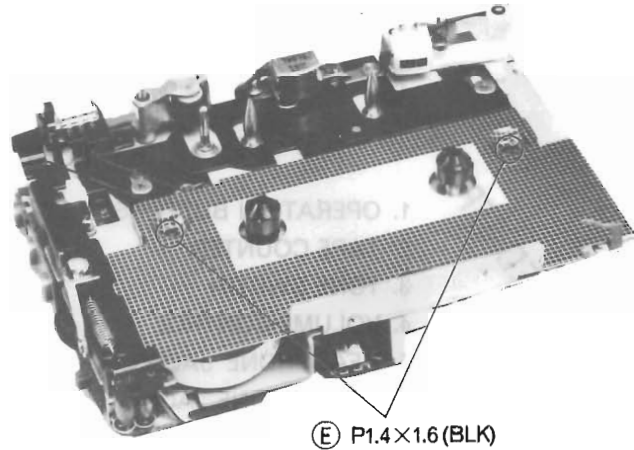

3. Rear case

1) Remove (C) (four) screws.

2) Lift the record button side of the chassis a little and take out the chassis carefully.

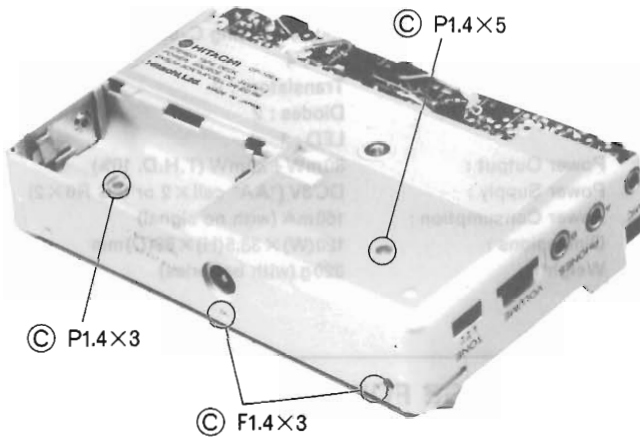

6. Eject/counter holder

Remove (F) (two) screws.

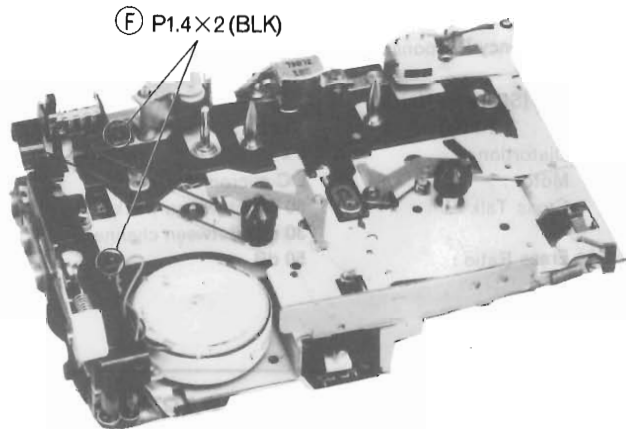

BLOCK DIAGRAM

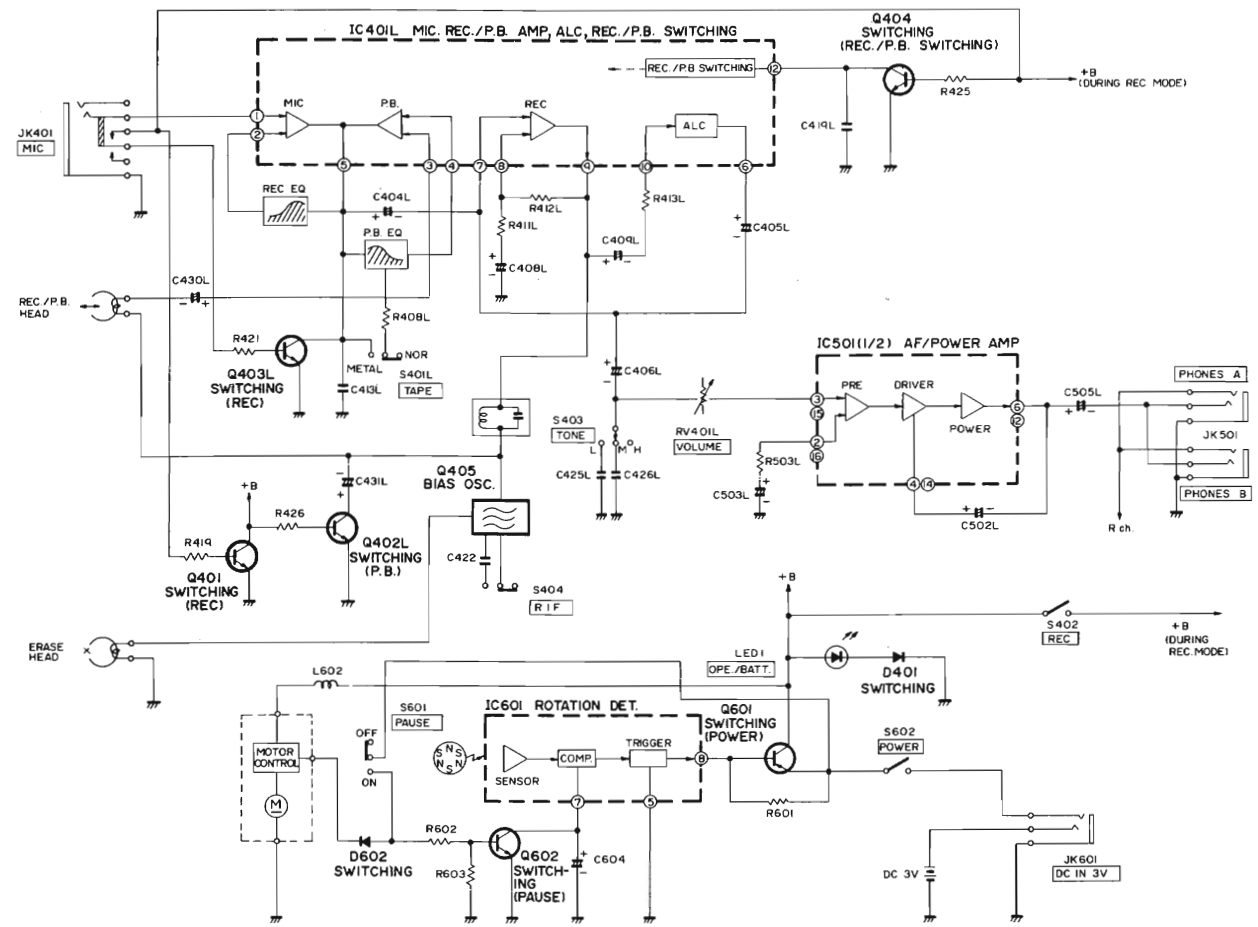

ADJUSTMENT

Perform the following adjustments in the sequence stated after cleaning the heads, pressure roller, and capstan with a head cleaning stick moistened in alcohol.

Step	Adjustment Item	Measuring Instrument and connection			Check Tape	Mode	Adjusted Position	Adjusted	Remarks
		Measuring Instrument	Input Terminal	Output Terminal					
1	Tape speed	• Frequency counter	—	Headphone jacks	Tape speed adjustment tape (3,000Hz)	Playback	Semivariable resistor in the motor PC board	3,005 Hz ±10Hz	Note 1
2	Head azimuth	• VTVM	—	Headphone jacks	Head azimuth adjustment tape (10 kHz)	Playback	Azimuth adjusting screw	Output Max.	Note 2
3	Record bias	• VTVM	—	Both ends of R430R (10Ω)	—	Record	RT401	3.7mV	Note 3

Note :

1. Adjust within 30 sec. after heat-running for more than 20 minutes.
2. When the maximum values of both channels are different, adjust to the maximum value of the L channel. In this case, the difference between the maximum values of both channels should be within 2 dB.
3. 1) Set the RIF switch to the "B" position in the recording mode.
2) Connect the VTVM to both ends of R430R (10Ω) and adjust RT401 so that the bias current is 3.7mV.

ERASE HEAD REPLACEMENT

Replace the erase head according to the procedure shown below.

1. Replace the erase head with the new one specified as replacement parts.

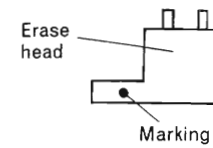

Erase heads in mass production products : Red, Blue or Black marking

Erase heads as replacement parts : No marking

2. Unsolder sections (A), (B), (C) and (D) shown below.

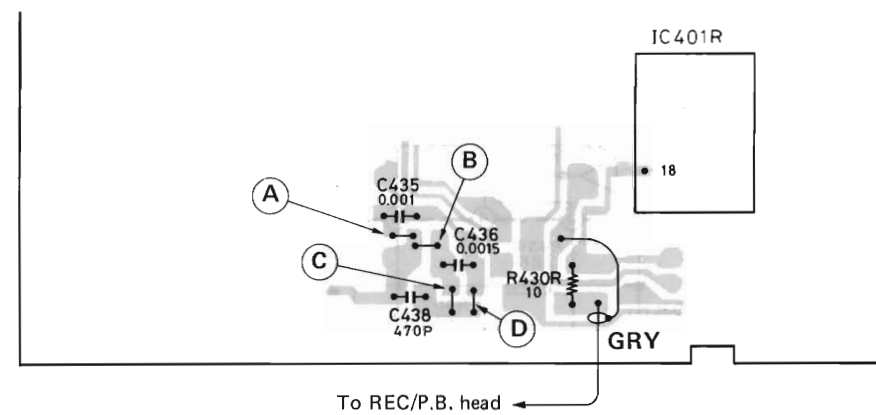

3. Solder section (E) shown below.

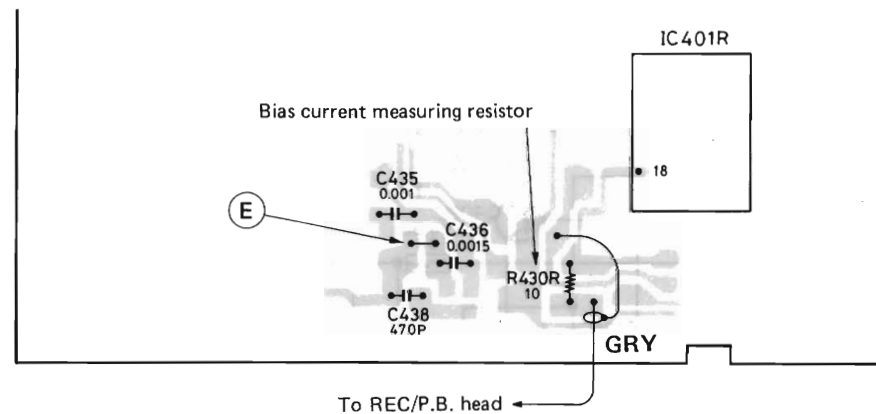

4. Re-adjust the record bias current according to Step 3 in page 3 "ADJUSTMENT".

SCHMATIC DIAGRAM

IC401L,R μPC1217G MIC, REC./P.B AMP, ALC, REC./P.B. SWITCHING	Q401 2SC1623(L5-6) SWITCHING (REC)	Q402L,R 2SC2462D SWITCHING (PLAY)	Q403L,R 2SC1623(L5-6) SWITCHING (REC.)	Q404 2SC1623(L5-6) SWITCHING (REC./PLAY)	Q405 2SC2603-E BIAS OSC	IC501 BA5204 AF/POWER AMP	D602 ISS133HV SWITCHING	Q602 2SC1623(L5-6) SWITCHING (PAUSE)	IC601 PST 517 ROTATION DET.	D401 MA152WA SWITCHING	LED1 SLC22UR OPE,BATT.	Q601 2SB1001 SWITCHING (POWER)
---	---	--	---	---	-------------------------------	------------------------------------	-------------------------------	---	--------------------------------------	------------------------------	------------------------------	---

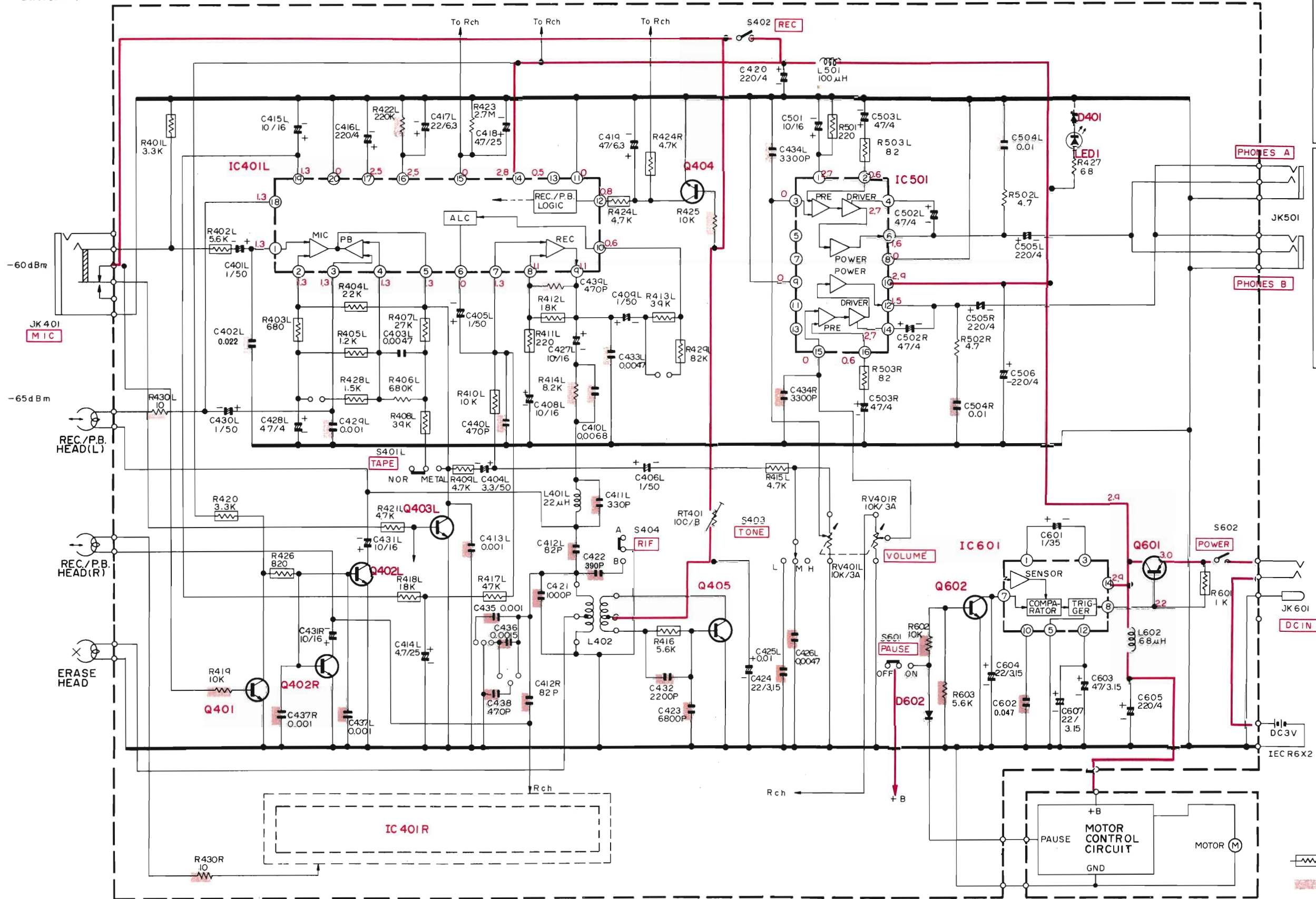

Note

1. Voltage measured at base of chassis with minimum volume control and no signal.
2. Nomenclature of Resistors and Capacitors.

Circuit No.	
Value	No indicated Ω(Ohm) M : 1000KΩ
Tolerance	No indicated ±5% K : ±10% M : ±20%
Wattage	No indicated ¼W
Sort	No indicated Carbon film RC : Composition RW : Wire wound RS : Oxide metal film RN : Fixed metal film

Circuit No.	
Value	No indicated μF P : pF
Tolerance	No indicated ±10% J : ±5% M : ±20% Z : +80%, -20% D : ±0.5pF C : ±0.25pF
Sort	⊞ Ceramic ⊞ Electrolytic ⊞ Mylar ⊞ Polyester ⊞ Styrol
Voltage	No indicated 50WV

3. Be sure to make your orders of resistors and capacitors with value, voltage, tolerance and sort.
4. When replacing capacitors marked with *, use specified ones stated on parts list since required temperature characteristics.

⊞ : PRINTED RESISTORS
⊞ : CHIP PARTS

CIRCUIT BOARD DIAGRAM

- :CHIP PARTS
- :PRINTED RESISTORS
- :THROUGH HOLES

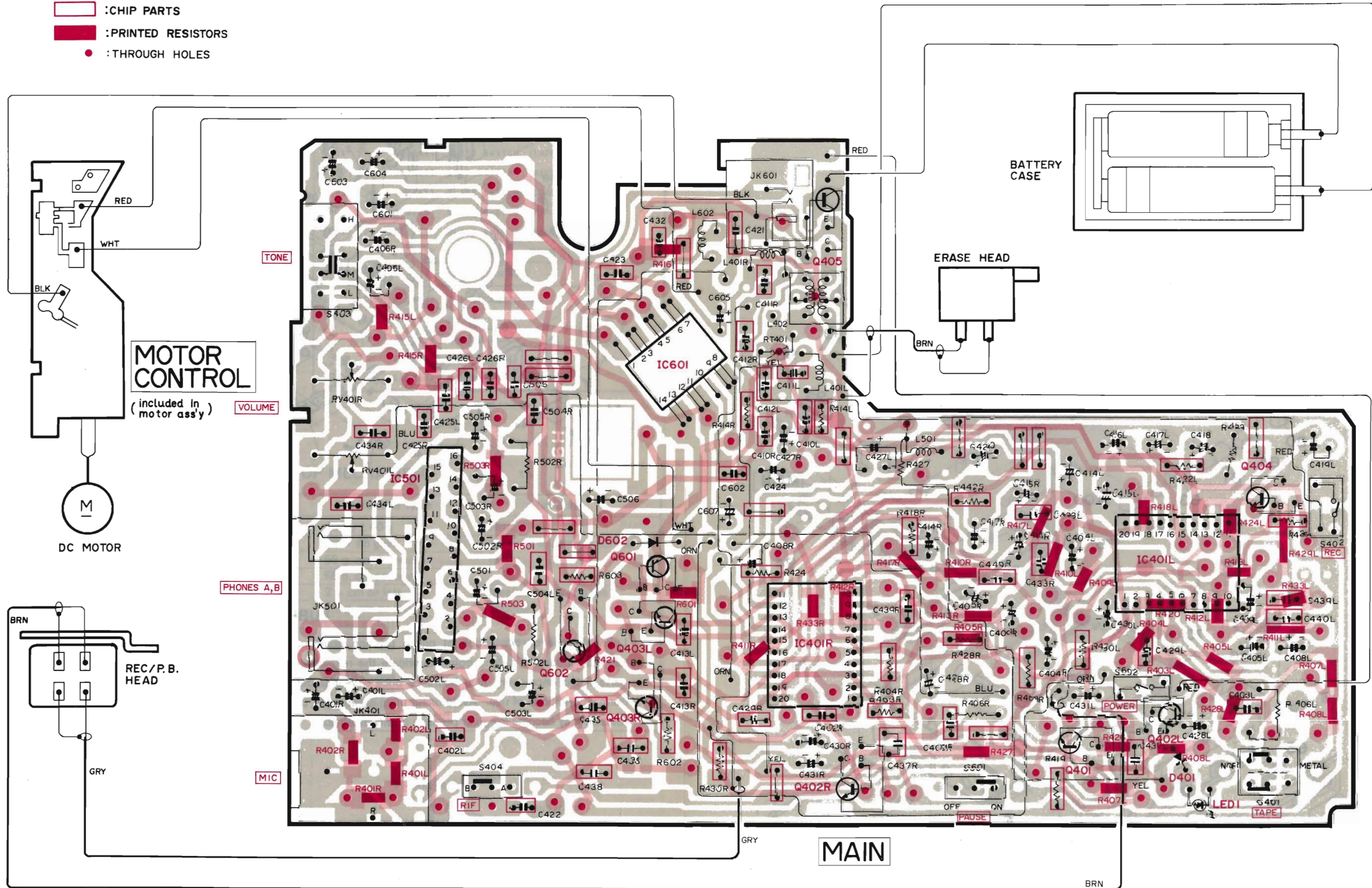

EXPLODED VIEW (Cabinet)

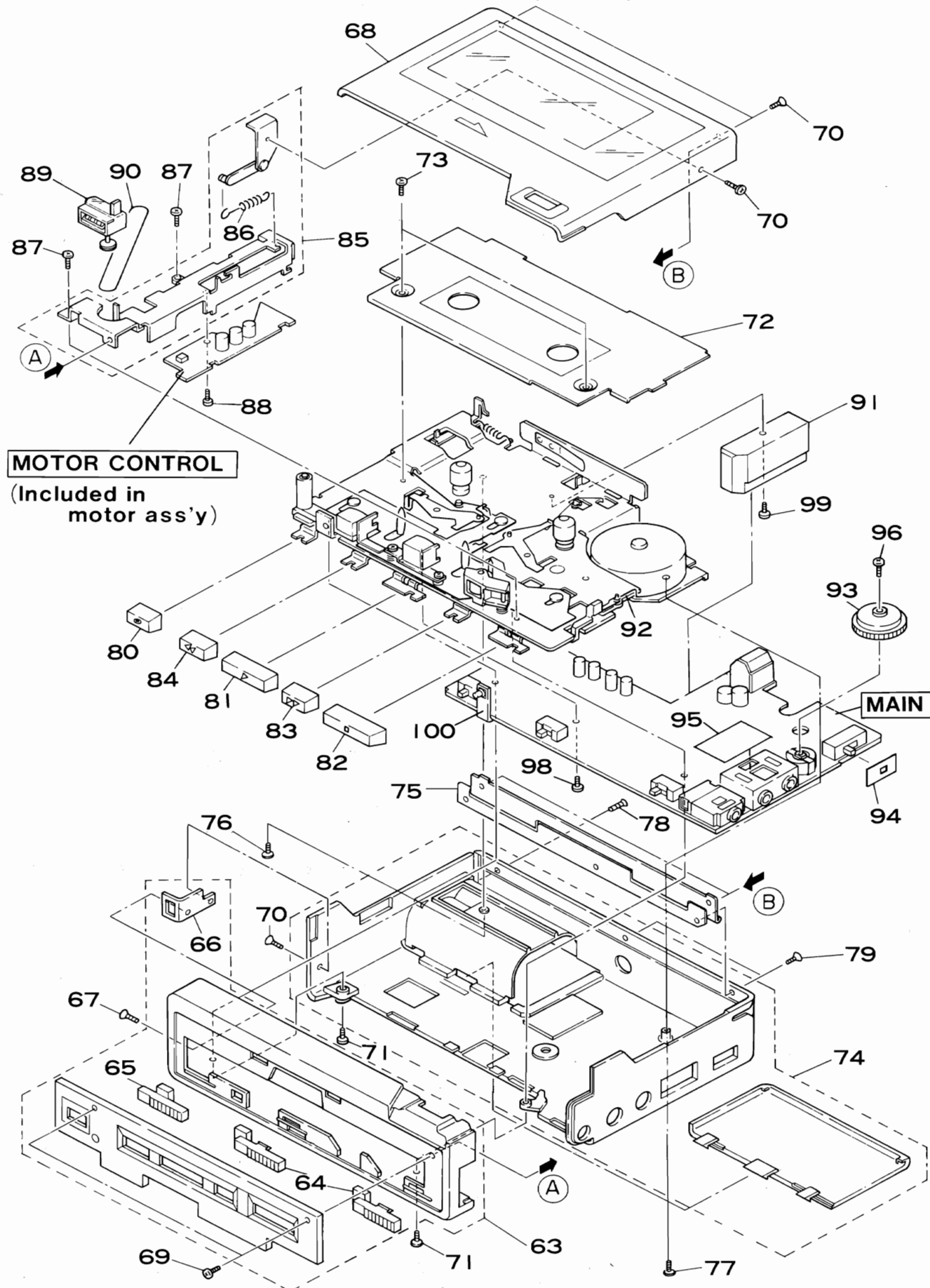

MOTOR CONTROL
(Included in motor ass'y)

MAIN

EXPLODED VIEW (Mechanism-SR-1A)

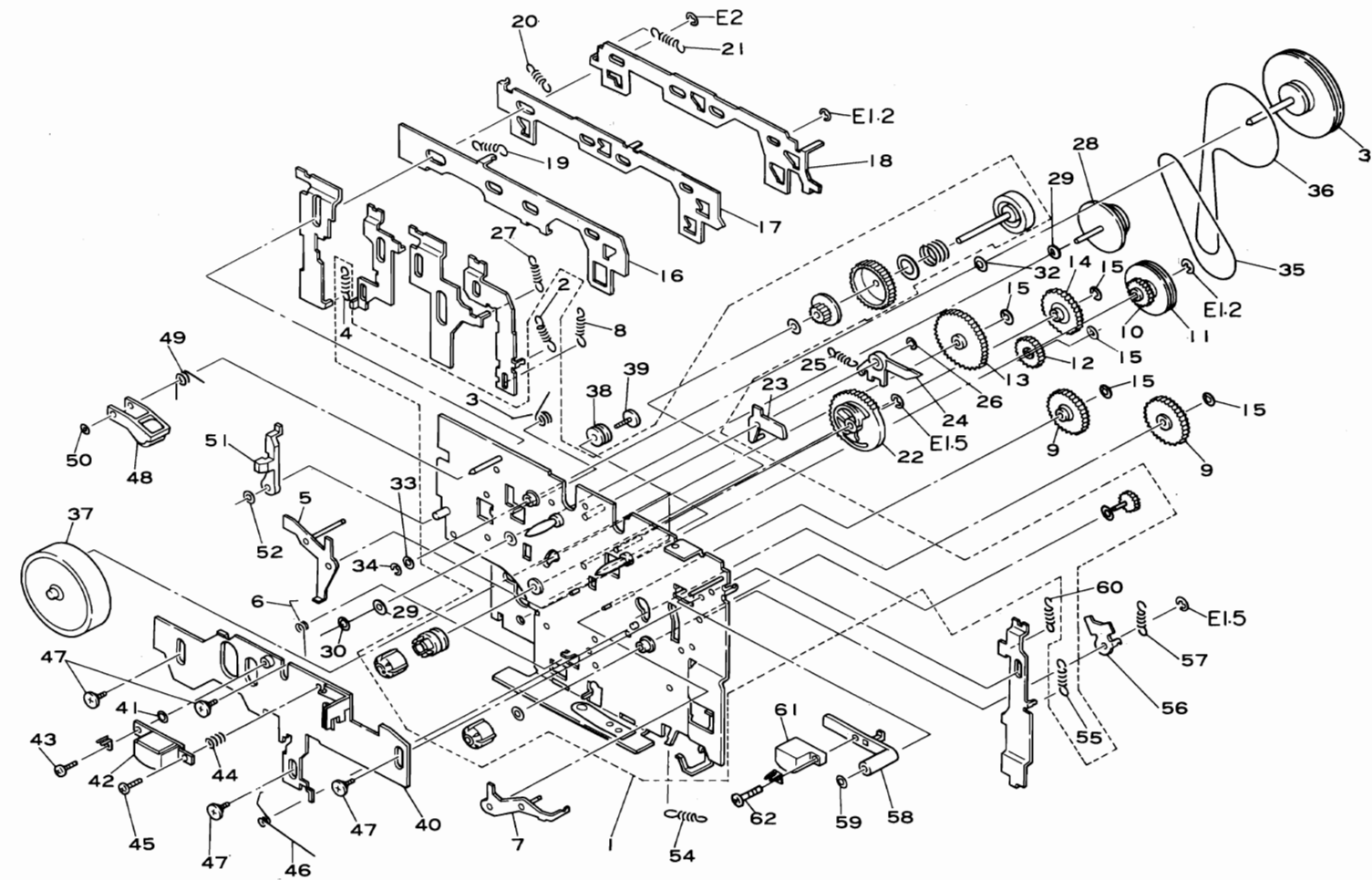

LUBRICATION

Lubricate one or two drops of oil to rotating point or lubricate grease to sliding point. Lubricate the respective parts listed once every 1000 hours or once a year under normal conditions of use. Avoid oiling them excessively, or rotation may become irregular because of oil splashes.

Lubrication point		Oil or Grease
Rotary section	Metal and metal	Pan motor oil (10W-40)
	Mold and metal	Sonic slider oil (#1600)
Sliding section	Metal and metal	Hitasol (MO-138)
	Mold and mold Mold and metal	Floil (GB-TS-1)
Spring resonance prevention		Floil (GB-TS-1)

Note: Components marked without numbers in this drawing are not specified as replacement parts.

REPLACEMENT PARTS LIST

SYMBOL-NO	P-NO	DESCRIPTION	SYMBOL-NO	P-NO	DESCRIPTION
MECHANISM (SR - 1A)			46	6548516	HEAD PLATE SPRING
1	7044231	SUB CHASSIS ASSEMBLY	47	7782822	SPECIAL SCREW
2	6543124	SPRING	48	6774491	PRESSURE ROLLER ARM ASSEMBLY
3	6548487	SPRING	49	6548533	SPRING
4	6543072	SPRING	50	7787563	POLY SLIDER WASHER
5	7350762	F.F ARM ASSEMBLY	51	6774581	REVIEW/CUE ARM
6	6548521	SPRING	52	7787563	POLY SLIDER WASHER
7	7350781	REWIND ARM ASSEMBLY	53	—	—
8	6543091	SPRING	54	6542512	GEAR SPRING
9	6432491	REWIND IDLER GEAR	55	6543071	SPRING
10	6432462	GEAR	56	7350931	RECORD PLATE
11	6423032	MIDDLE PULLEY	57	6543102	SPRING
12	6432442	PLAY IDLER GEAR	58	6775081	ERASE HEAD ARM
13	6432451	F.F IDLER GEAR	59	7787563	POLY SLIDER WASHER
14	6432621	POWER ASSIST IDLER GEAR	60	6543082	SPRING
15	7787571	WASHER	61	5445521	ERASE HEAD
16	7350712	REVIEW/CUE PLATE	62	8691106	BT SCREW-2MMD x 6MM
17	7350722	LOCK PLATE	MISCELLANEOUS		
18	7354021	SWITCH PLATE	63	6244855	ESCUTCHEON ASSEMBLY
19	6543131	SPRING	64	6293443	SLIDE KNOB (PAUSE/RIF)
20	6543111	SPRING	65	6293401	SLIDE KNOB (TAPE)
21	6543082	SPRING	66	7351541	STRAP HOLDER
22	6432524	POWER ASSIST CAM GEAR	67	8722005	FLAT SCREW-1.4MMDX3MM
23	6774461	PLAY LOCK ARM	68	6094325	CASSETTE LID ASSEMBLY
24	6774471	TRIGGER ARM	69	8714005	PAN HEAD SCREW-1.4MMDX4MM
25	6542514	SPRING	70	8722005	FLAT SCREW-1.4MMDX3MM
26	7788591	WASHER	71	8712027	PAN HEAD SCREW-1.4MMDX5MM
27	6543151	SPRING	72	6636732	DECORATION METAL
28	6423053	ANTI PULLEY ASSEMBLY	73	8714022	PAN HEAD SCREW-1.4MMDX1.6MM
29	7778854	POLY SLIDER WASHER	74	6037205	REAR CASE ASSEMBLY
30	7786213	WASHER	75	6337512	HINGE ASSEMBLY
31	6374292	FLYWHEEL ASSEMBLY	76	8712024	PAN HEAD SCREW-1.4MMDX3MM
32	7772625	SPRING	77	8712027	PAN HEAD SCREW-1.4MMDX5MM
33	7786119	POLY SLIDER WASHER	78	8722004	FLAT SCREW-1.4MMDX2MM
34	7774841	E RING-1.6MMD	79	8722005	FLAT SCREW-1.4MMDX3MM
35	6355791	BELT	80	6058011	BUTTON (RECORD)
36	6355521	BELT-1.0MMD	81	6058033	BUTTON (PLAY)
37	5577661	DC MOTOR	82	6058034	BUTTON (STOP)
38	6590271	RUBBER PLATE	83	6058023	BUTTON (F.F)
39	7782831	SCREW FOR MOTOR MOUNTING	84	6058024	BUTTON (REWIND)
40	7350744	HEAD PLATE ASSEMBLY	85	7351694	EJECT/COUNTER HOLDER ASSEMBLY
41	7779923	WASHER	86	6543043	SPRING
42	5449281	RECORD PLAYBACK HEAD	87	8714023	PAN HEAD SCREW-1.4MMDX2MM
43	8741103	SCREW (2MMD x 3MM)	88	8712024	PAN HEAD SCREW-1.4MMDX3MM
44	6520683	HEAD SPRING	89	5559621	COUNTER
45	7780553	SPECIAL SCREW-2MMDX6MM	90	6355721	COUNTER BELT

SYMBOL-NO	P-NO	DESCRIPTION	SYMBOL-NO	P-NO	DESCRIPTION
MISCELLANEOUS			C435	0247003	CERAMIC CHIP 1000PF+-20X
91	6771586	BATTERY TERMINAL HOLDER ASSEMBLY	C436	0247056	CERAMIC CHIP 1500PF+-10X
92	6548606	SPRING	C437LR	0247003	CERAMIC CHIP 1000PF+-20X
93	6292492	VOLUME KNOB	C438	0247039	CERAMIC CHIP 470PF+-5X
94	7765792	SPACER	C439LR	0247039	CERAMIC CHIP 470PF+-5X
95	7766889	SPACER	C440LR	0247039	CERAMIC CHIP 470PF+-5X
96	7780901	PAN HEAD SCREW-1.7MMDX4MM	C501	0256155	ELECTROLYTIC 10UF 16V
97	—	—	C502LR	0256166	ELECTROLYTIC 47MF,4V
98	8722023	FLAT SCREW-1.4MMDX3MM	C503LR	0256166	ELECTROLYTIC 47MF,4V
99	8712024	PAN HEAD SCREW-1.4MMD x 3MM	C504LR	0247007	CERAMIC CHIP 0.01UF+-20X
100	6774831	LED HOLDER	C505LR	0256162	ELECTROLYTIC 220MF 4V
CAPACITORS			C506	0256162	ELECTROLYTIC 220MF 4V
C401LR	0256366	TANTALUM 1.0UF 35V	C601	0256366	TANTALUM 1.0UF 35V
C402LR	0247010	CERAMIC CHIP 0.022 MF+-20%	C602	0247072	CERAMIC CHIP 0.047 MF+-10X
C403LR	0247061	CERAMIC CHIP 4700PF+-10X	C603	0256395	TANTALUM ELECTROLYTIC 47MF 3V
C404LR	0256153	ELECTROLYTIC 3.3UF 50V	C604	0256391	TANTALUM ELECTROLYTIC 22MF 3.15V
C405L	0256151	ELECTROLYTIC 1.0UF 50V	C605	0256162	ELECTROLYTIC 220MF 4V
C405R	0256366	TANTALUM 1.0UF 35V	C606	0247003	CERAMIC CHIP 1000PF+-20X
C406LR	0256366	TANTALUM 1.0UF 35V	C607	0256391	TANTALUM ELECTROLYTIC 22MF 3.15V
C408LR	0256155	ELECTROLYTIC 10UF 16V	RESISTORS		
C409LR	0256151	ELECTROLYTIC 1.0UF 50V	RT401	5007441	SEMI VARIABLE 100 OHM
C410LR	0247062	CERAMIC CHIP 6800PF+-10X	RV401	5008821	VARIABLE RESISTOR 10KOHM(A)
C411LR	0247037	CERAMIC CHIP 330PF+-5X	R001-013	0127972	CHIP JUMPER RESISTOR
C412LR	0247030	CERAMIC CHIP 82PF+-5X	R403R	0127933	CHIP RESISTOR 680 OHM+-5X
C413LR	0247003	CERAMIC CHIP 1000PF+-20X	R404R	0127951	CHIP RESISTOR 22KOHM+-5X
C414LR	0256154	ELECTROLYTIC 4.7UF 25V	R405R	0127936	CHIP RESISTOR 1.2KOHM+-5X
C415LR	0256155	ELECTROLYTIC 10UF 16V	R409R	0127943	CHIP RESISTOR 4.7KOHM+-5X
C416LR	0256162	ELECTROLYTIC 220MF 4V	R414LR	0127946	CHIP RESISTOR 8.2KOHM+-5X
C417LR	0256161	ELECTROLYTIC 22MF 6.3V	R418R	0127950	CHIP RESISTOR 18KOHM+-5X
C418	0256154	ELECTROLYTIC 4.7UF 25V	R419	0127947	CHIP RESISTOR 10KOHM+-5X
C419	0256166	ELECTROLYTIC 47MF 4V	R422LR	0127963	CHIP RESISTOR 220KOHM+-5X
C420	0256162	ELECTROLYTIC 220MF 4V	R424R	0127943	CHIP RESISTOR 4.7KOHM+-5X
C421	0247003	CERAMIC CHIP 1000PF+-20X	R425	0127947	CHIP RESISTOR 10KOHM+-5X
C422	0247038	CERAMIC CHIP 390 PF+-5X	R428R	0127937	CHIP RESISTOR 1.5KOHM+-5X
C423	0247062	CERAMIC CHIP 6800PF+-10X	R430LR	0127911	CHIP RESISTOR 10 OHM+-5X
C424	0256391	TANTALUM ELECTROLYTIC 22MF,3.15V	R602	0127947	CHIP RESISTOR 10KOHM+-5X
C425LR	0247007	CERAMIC CHIP 0.01UF+-20X	R603	0127944	CHIP RESISTOR 5.6KOHM+-5X
C426LR	0247061	CERAMIC CHIP 4700PF+-10X	SEMI-CONDUCTORS		
C427LR	0256386	TANTALUM ELECTROLYTIC 10MF,3.15V	D401	5329302	MICRO PACKAGE DIODE MA152WA
C428LR	0256166	ELECTROLYTIC 47MF,4V	D602	5331591	DIODE 1SS133HV
C429LR	0247003	CERAMIC CHIP 1000PF+-20X	IC401LR	5355702	IC #PC1217G
C430LR	0256151	ELECTROLYTIC 1.0UF 50V	IC501	5355691	IC BA5204
C431LR	0256155	ELECTROLYTIC 10UF 16V	IC601	5355872	IC PST517
C432	0247057	CERAMIC CHIP 2200PF+-10X	LED1	5380621	LED SLC-22UR
C433LR	0247061	CERAMIC CHIP 4700PF+-10X			
C434LR	0247059	CERAMIC CHIP 0.033MF+-20X			

SYMBOL-NO	P-NO	DESCRIPTION	SYMBOL-NO	P-NO	DESCRIPTION
SEMI-CONDUCTORS			L501	5152472	CHOKE COIL 100 MICRO H
Q401	5329043	MICRO PACKAGE TRANSISTOR 2SC1623(L5-6)	L602	5152561	CHOKE COIL 68 MICR H
Q402LR	5329192	MICRO PACKAGE TRANSISTOR 2SC2462D	MISCELLANEOUS		
Q403LR	5329043	MICRO PACKAGE TRANSISTOR 2SC1623(L5-6)	JK401	5673491	JACK-3.5MMD (MIC)
Q404	5329043	MICRO PACKAGE TRANSISTOR 2SC1623(L5-6)	JK501	5679942	JACK (PHONES A, B)
Q405	5323011	TRANSISTOR 2SC2603E	JK601	5672091	DC JACK
Q601	5329681	MICRO PACKAGE TRANSISTOR 2SB1031	S401	5622461	SLIDE SWITCH (TAPE)
Q602	5329043	MICRO PACKAGE TRANSISTOR 2SC1623(L5-6)	S402	5603432	LEAF SWITCH (REC)
COILS			S403	5622451	SLIDE SWITCH (TONE)
L401LR	5152652	CHOKE COIL	S404	5622481	SLIDE SWITCH (RIF)
L402	5261232	BIAS OSCILLATOR COIL	S601	5622481	SLIDE SWITCH (PAUSE)
			S602	5603432	LEAF SWITCH (POWER)
			FOR ACCESSORIES		
			5732142		HEADPHONE (HD-10P)
			7753453		BELT
			6037121		CARRYING CASE
			5792151		BATTERY CASE
			5421902		MICROPHONE (UCM-400W)



HITACHI SALES CORPORATION OF AMERICA
Eastern Regional Office
 1200 Wall Street West, Lyndhurst, New Jersey 07071,
 U.S.A.
 Tel. 201-935-8980

Mid-Western Regional Office
 1400 Morse Ave., Elk Grove Village, Ill. 60007, U.S.A.
 Tel. 312-593-1550

Southern Regional Office
 510 Plaza Drive, College Park, Georgia 30349, U.S.A.
 Tel. 404-763-0360

Western Regional Office
 401 West Artesia Boulevard, Compton, California 90220
 U.S.A.
 Tel. 213-537-8383

HITACHI SALES CORPORATION OF HAWAII, INC.
 3219 Koapaka Street, Honolulu, Hawaii 96819, U.S.A.
 Tel. 808-836-3621

HITACHI (HSC) CANADA INC.
 3300 Trans-Canada Highway, Pointe Claire, Quebec,
 H9RU1B1, Canada
 Tel. 514-697-9150

HITACHI SALES EUROPA GmbH
 Postfach 801060 Rungedamm 2, 2050 Hamburg 80,
 West Germany
 Tel. 040-734 11-0

HITACHI SALES (U.K.) Ltd.
 Hitachi House, Station Road, Hayes, Middlesex UB3
 4DR, England
 Tel. 01-848-8787

HITACHI SALES SCANDINAVIA AB
 Rissneleden 8, Box 7138, 172-07 Sundbyberg, Sweden
 Tel. 08-98 52 80

HITACHI SALES NORWAY A/S
 Oerebekk 1620, Gressvik, P.O. Box 46, N-1601,
 Fredrikstad, Norway
 Tel. 032-28255

SUOMEN HITACHI OY
 Takojankatsu 5, 15800 Lahti 80, Finland
 Tel. Lahti 44 241

HITACHI SALES A/S
 Kuldysen 13, DK-2630, Taastrup, Denmark
 Tel. 02-999200

HITACHI SALES A.G.
 Bahnhofstrasse, 19, 5600 Lenzburg, Switzerland
 Tel. 064-513621

HITACHI SALES WARENHANDELS GMBH
 A-1180/Wien, Kreuzgasse 27, Austria
 Tel. 0222-439367

HITACHI-FRANCE S.A.
 95-101 Rue Charles Michels,
 93200 SAINT-DENIS, France
 Tel. 821 6015

HITACHI SALES ITALIANA, S.P.A.
 Via Cristoforo Colombo 49, Trezzano sul naviglio
 (Milano), Italy
 Tel. 02-44 59 031

HITACHI SALES BELGIUM S.A.
 56, Chaussee de Namur B-1400 Nivelles, Belgium
 Tel. (003267) 227181

HITACHI SALES IBERICA, S.A.
 Gran Via Carlos Tercero, 101, 1-1, Barcelona-28,
 Spain
 Tel. 330-8652

HITACHI SALES AUSTRALIA Pty Ltd.
 153 Keys Road, Moorabbin, Victoria 3189 Australia
 Tel. 555-8722

HITACHI Ltd. TOKYO JAPAN
 Head Office: THE HITACHI ATAGO BLDG.
 No. 15-12, 2-Chome Nishi-Shinbashi
 Minato-Ku, Tokyo 105, Japan
 Tel. Tokyo (03) 502-2111

INSPECTION OF MECHANISM

Item	Checking item	Reference value	Remarks	
1	Pressure of pressure roller	200 g ± 40 g	Note 1	
2	Take-up torque	30 ~ 65 g.cm	Measure in cassette torque meter	
3	Fast forward torque	55 g. cm or more		
4	Rewin torque	55 g. cm or more		
5	Back tension torque	2 g. cm or less		Measure without tape counter
6	Button operation force	Supply	4.5 g. cm or less	
		Play button	0.3 kg or less	Measure without leaf switches (REC, Power)
		Fast forward button	0.8 kg or less	
		Rewind button	0.5 kg or less	
		Stop button	0.5 kg or less	
7	Flywheel thrust gap	0.1 ~ 0.2 mm		

Note:

1. Set this unit in the playback mode and press the pressure roller in the direction of the arrow using a fan type tension gauge, and measure the pressure when the pressure roller is released from the capstan.

