



# HITACHI

## SERVICE MANUAL

TK

No. 1896E

**CP-90S/CP-900S**

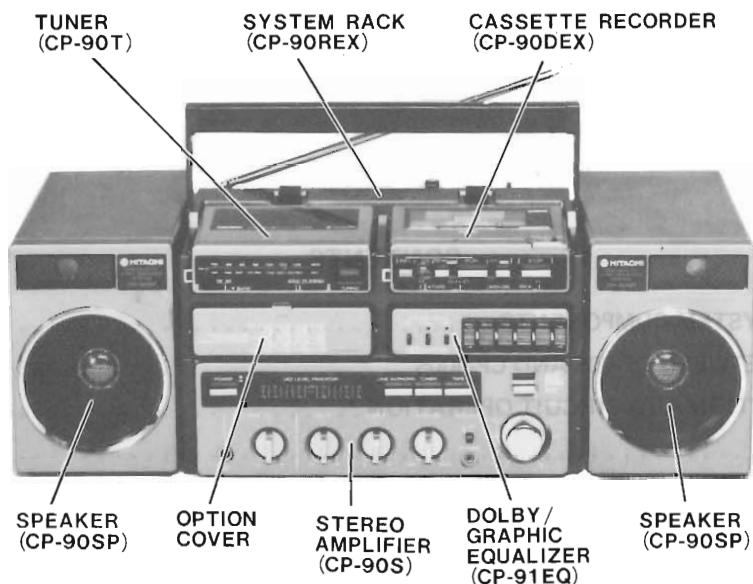

<CP-90S>

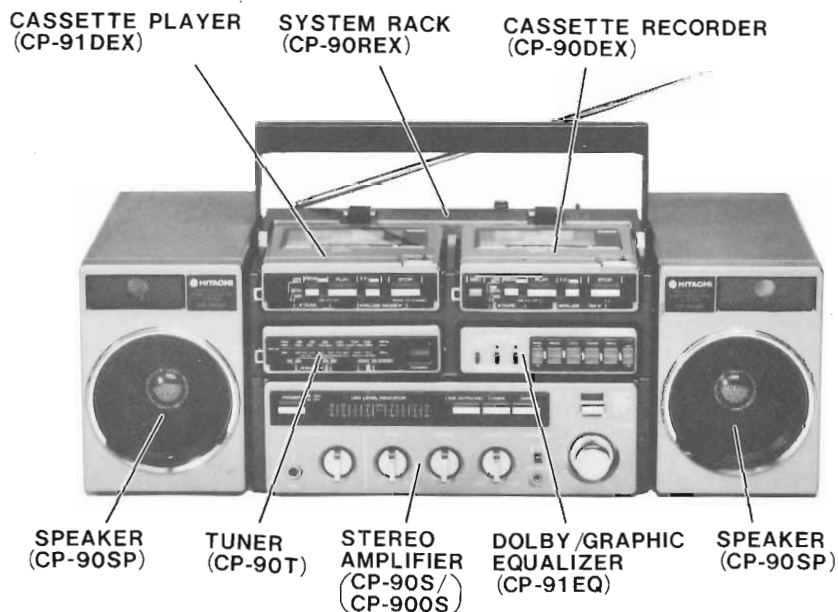

<CP-900S>

SPECIFICATIONS AND PARTS ARE SUBJECT TO CHANGE FOR IMPROVEMENT

**RADIO CASSETTE TAPE RECORDER**

March 1983

TOKAI WORKS

**SAFETY PRECAUTIONS**

The following precautions should be observed when servicing.

1. Since many parts in the unit have special safety-related characteristics, always use genuine Hitachi's replacement parts. Especially critical parts in the power circuit block should not be replaced with other makes. Critical parts are marked with  in the schematic diagram and circuit board diagram.
2. Before returning a repaired unit to the customer, the service technician must thoroughly test the unit to ascertain that it is completely safe to operate without danger of electrical shock.
3. Before returning a repaired unit to the customer, the service technician must measure the leakage-current or resistance to determine that the exposed parts are acceptably insulated from the power circuit.

**CONTENTS**

CP-90S/CP-900S SYSTEM COMPONENTS .....	3
DIFFERENCES BETWEEN CP-90S AND CP-900S .....	3
SYSTEM CONNECTION AND CIRCUIT OPERATION .....	4
1. CP-90S .....	4
2. CP-900S .....	7
DESCRIPTION OF NEW CIRCUIT .....	10
1. SBBS (Super Bass Boost System) circuit (CP-90S/CP-900S) .....	10
2. AC-DC combination erase head (CP-90DEX) .....	11
CAUTIONS ON REPAIRING PRINTED RESISTOR .....	11
TUNER CP-90TH/TE/TW .....	13
STEREO AMPLIFIER CP-90S/900S, SYSTEM RACK CP-90REX, SPEAKER CP-90SP .....	33
STEREO CASSETTE RECORDER CP-90DEX .....	55
DOLBY/GRAPHIC EQUALIZER CP-91EQ .....	69
STEREO CASSETTE PLAYER CP-91DEX .....	77

CP-90S/CP-900S SYSTEM COMPONENTS

Model Components		CP-90S						CP-900S			
		H	HC	E	E(BS)	EZ	EW	E	AU	W	W(HK)
Stereo Amplifier	CP-90S	○	○	○	○	○	○	○			
	CP-900S								○	○	○
Tuner	CP-90TH	○	○								
	CP-90TE			○	○	○	○	○			
	CP-90TW								○	○	○
Cassette Recorder	CP-90DEX	○	○	○	○	○	○	○	○	○	○
Dolby/Graphic Equalizer	CP-91EQ	○	○	○	○	○	○	○	○	○	○
System Rack	CP-90REX	○	○	○	○	○	○	○	○	○	○
Speaker	CP-90SP	○	○	○	○	○	○	○	○	○	○
Cassette Player	CP-91DEX							○	○	○	○

DIFFERENCES BETWEEN CP-90S AND CP-900S

- The cassette player (CP-91DEX) is not provided in the CP-90S.
- The position where the tuner is assembled in the rack is different.
- The function select buttons to be pressed are different as shown below.

Details of operation		Function select button to be pressed	
		CP-90S	CP-900S
<ul style="list-style-type: none"> <li>• When listening to radio or when recording while listening to radio</li> <li>• When recording from the wireless microphone</li> <li>• When mixing playback or mixing recording of radio and wire microphone</li> </ul>		LINE IN /PHONO <input type="checkbox"/> TUNER <input checked="" type="checkbox"/> TAPE <input type="checkbox"/>	TUNER/ LINE IN /PHONO <input checked="" type="checkbox"/> TAPE <input type="checkbox"/> TAPE <input type="checkbox"/>
	<ul style="list-style-type: none"> <li>• When recording from the wire microphone</li> </ul>	<input checked="" type="checkbox"/> <input type="checkbox"/> <input type="checkbox"/>	<input type="checkbox"/> <input checked="" type="checkbox"/> <input type="checkbox"/>
	<ul style="list-style-type: none"> <li>• When playing the tape or when mixing playback of the tape and wire microphone</li> </ul>	Cassette recorder <input type="checkbox"/> <input type="checkbox"/> <input checked="" type="checkbox"/> Cassette player <input type="checkbox"/> <input checked="" type="checkbox"/> <input type="checkbox"/>	<input type="checkbox"/> <input type="checkbox"/> <input checked="" type="checkbox"/> <input type="checkbox"/> <input checked="" type="checkbox"/> <input type="checkbox"/>
<ul style="list-style-type: none"> <li>• When recording while mixing tape and wire microphone</li> </ul>		<input type="checkbox"/> <input checked="" type="checkbox"/> <input type="checkbox"/>	<input type="checkbox"/> <input checked="" type="checkbox"/> <input type="checkbox"/>

shows the button to be pressed.

## SYSTEM CONNECTION AND CIRCUIT OPERATION

## 1. CP-90S

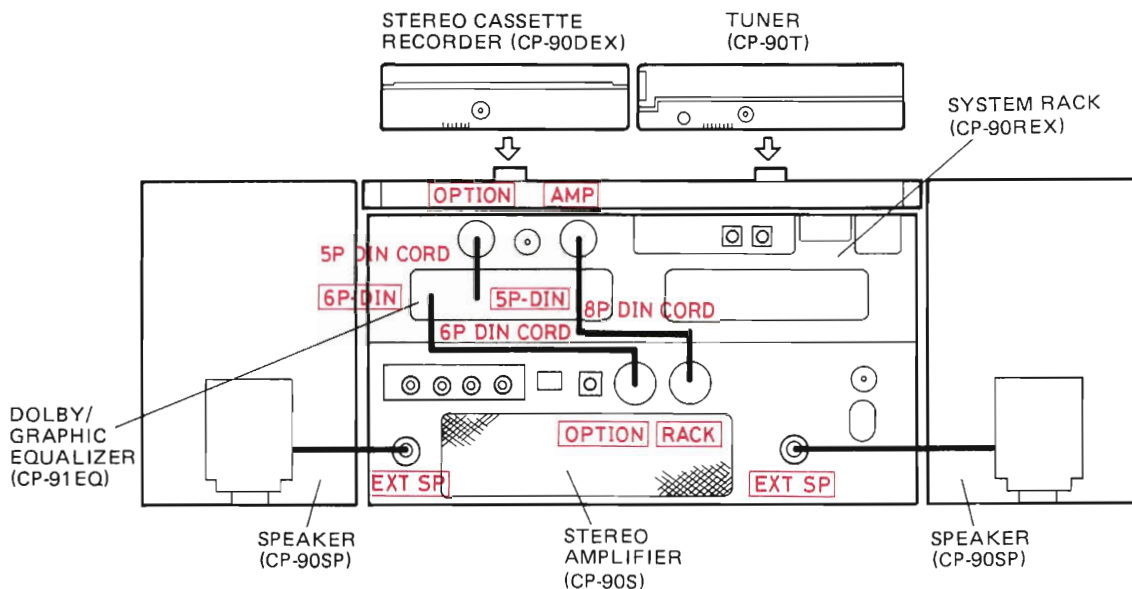

## (1) When the Tuner (CP-90T) is operating

The TUNER switch (S403) is set to ON, so the +3V power is derived from JK403 pin ⑧ of CP-90S and input to 8P pin connector pin ④ of CP-90T via CP-90REX.

The radio signal is derived from 8P pin connector pin ① (right) and pin ② (left) and input to JK403 pin ④ (left) and pin ⑤ (right) of CP-90S via CP-90REX. The LINE IN/PHONO switch (S404) and the TAPE switch (S402) have

been switched over to OFF, so the radio signal is amplified by Q401 and IC402, derived from JK404 pin ② (right) and pin ⑤ (left) and sent to the Dolby/Graphic Equalizer (CP-91EQ). The radio signal with its tone controlled by the graphic equalizer amplifier (IC803) is sent to CP-90S from DIN802 pin ① (right) and pin ③ (left) and is derived via the volume control/amplifier circuits.

## (2) When the stereo cassette recorder (CP-90DEX) is operating

## 1) During play

The TAPE switch (S402) is set to ON, so the TUNER switch (S403) and the LINE IN/PHONO switch (S404) are switched over to OFF. The +3V power is supplied to 8P pin connector pin ④ from JK403 pin ② via CP-90REX.

The play signal is amplified by the preamplifier (IC401), output from 8P pin connector pin ① (right) and pin ② (left) and sent to CP-90REX. The DIN switch (S951) has been switched over to ON, so the play signal is sent to DIN 801 of CP-91EQ from JK951 pin ③ (right) and pin ⑤ (left) and decoded via the play Dolby NR circuit, then it is sent to JK951 of CP-90REX from DIN801 pin ① (left) and pin ④ (right). This play signal is applied to CP-90S from JK952 pin ① (right) and pin ③ (left), and is output via the graphic equalizer circuit the same as during CP-90T operation.

## 2) During recording

The TUNER switch (S403) is set to ON during recording of the tuner signal and the LINE IN/PHONO switch (S404) is set to ON during recording of line input (or phono input) signal, so the TAPE switch (S402) is changed over to OFF.

The record signal is amplified by Q401 and IC402, and derived from JK403 pin ① (right) and pin ③ (left) via Q402 and S402, then it is sent to CP-90REX. This record signal is applied to DIN801 of CP-91EQ from JK951 pin ① (left) and pin ④ (right), and encoded via the record Dolby NR circuit, then it is derived from DIN801 pin ③ (right) and pin ⑤ (left). This output is sent to 8P pin connector pin ① (right) and pin ② (left) of CP-90DEX via CP-90REX and recorded via the record amplifier (IC401).

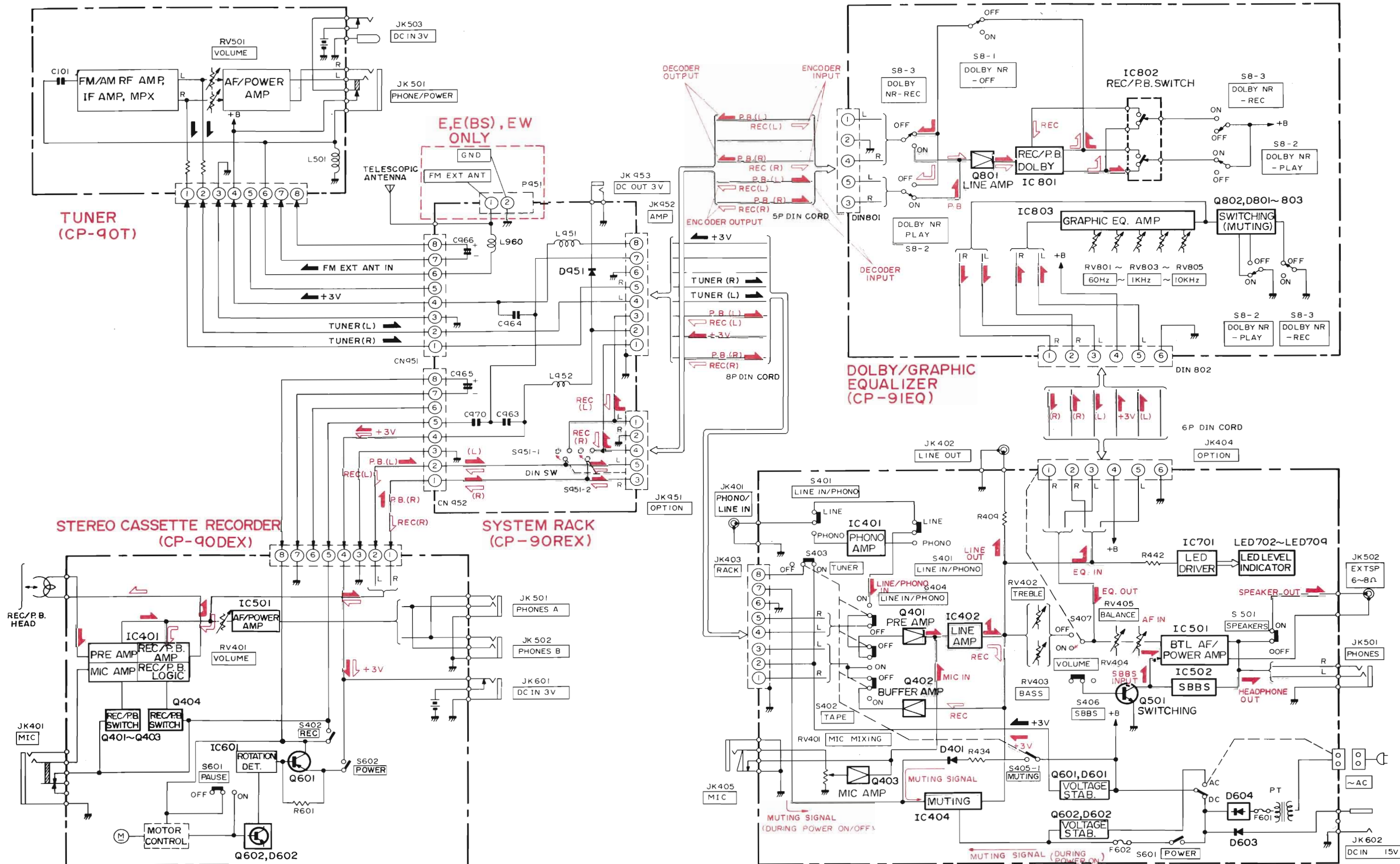

2. CP-900S

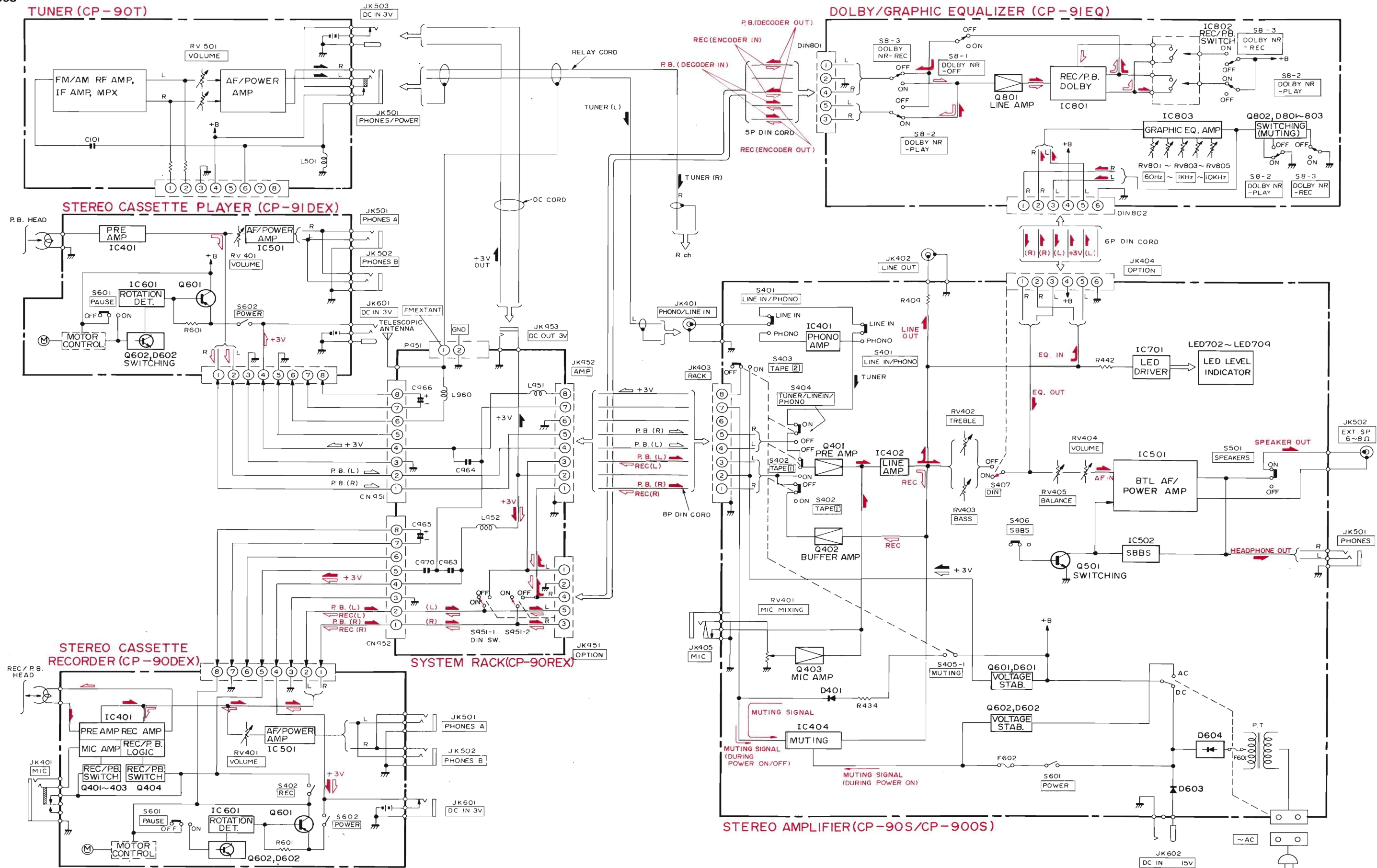

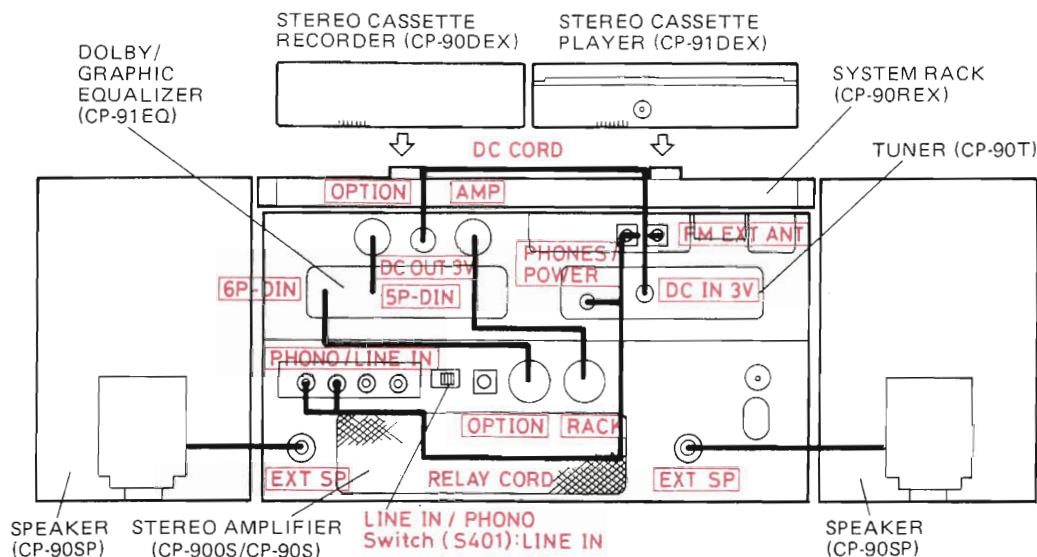

### (1) When the Tuner (CP-90T) is operating

The +3V power is input to the DC IN3V jack (JK503) from JK403 pin ② of CP-900S/CP-90S via the DC OUT 3V jack (JK953) of CP-90REX. The relay cord plug is inserted into the headphone jack (JK501), so this +3V power input is supplied to the circuit via JK501.

The radio signal is output from JK501 and sent to the PHONO/LINE IN jack (JK401). The LINE IN/PHONO select switch (S401) is switched to LINE IN and the TUNER/LINE IN/PHONO switch (S404) to ON, so the signal is fed to the amplifier circuit via S401 and S404. S407 is a DIN switch with OPTION jack (JK404) built-in and switched over to ON when the 6P DIN cord is connected to JK404, so the signal amplified via the line amplifier (IC402) is sent to the Dolby NR/Graphic Equalizer circuit (CP-91EQ) from JK404 pin ⑤ (left) and pin ② (right) without passing through the tone control circuit, then it is input to JK404 pin ③ (left) and pin ① (right) again after adjusting its tone via the graphic equalizer amplifier (IC803), and is output via the volume control circuit and amplifier circuit.

The tuner output is changed according to the volume, so fix the volume to "6".

### (2) When the stereo cassette player (CP-91DEX) is operating

When the TAPE ② switch (S403) is switched over to ON, the +3V power is supplied to 8P pin connector pin ④ from CP-900S/CP-90S via CP-90REX and the stereo cassette player is operated when the power switch (S602) is set to ON by button operation.

The play signal is amplified by the preamplifier (IC401) and derived from 8P pin connector pin ① (right) and pin ② (left), then sent to rack input jack (JK403) pin ④ (left)

and pin ⑤ (right) of CP-900S/CP-90S via CP-90REX. This signal is output via the graphic equalizer as in operation of the CP-90T.

### (3) When the stereo cassette recorder (CP-90DEX) is operating

The +3V power is supplied to 8P pin connector pin ④ from JK403 pin ② of CP-900S/CP-90S via CP-90REX and the stereo cassette recorder is operated when the power switch (S602) is set to ON by button operation.

#### 1) During play

The play signal is amplified by the preamplifier (IC401) and derived from 8P pin connector pin ① (right) and pin ② (left), then sent to CP-90REX.

The DIN switch (S951) has been switched over to ON, so the play signal is sent to DIN801 of the Dolby NR/Graphic Equalizer (CP-91EQ) from JK951 pin ③ (right) and pin ⑤ (left) without passing through the switch, decoded by the play Dolby NR circuit, derived from DIN801 pin ① (left) and pin ④ (right) again and sent to JK951 of CP-90REX.

This play signal is further sent to CP-900S/CP-90S from JK952 pin ① (right) and pin ③ (left).

#### 2) During recording

The TUNER/LINE IN/PHONO switch (S404) is set to ON during recording of the tuner signal and the TAPE ② switch (S403) is set to ON during recording (dubbing) of the signal from the stereo cassette player, so the TAPE ① switch (S402) is switched to OFF. The record signal is amplified by Q401 and IC402, and derived from JK403 pin ① (right) and pin ③ (left) via Q402 and S402, then it is sent to CP-90REX. This record signal is

supplied to DIN801 of CP-91EQ from JK951 pin ① (left) and pin ④ (right), and encoded via the record Dolby NR circuit, then it is output from DIN801 pin ③ (right) and pin ⑤ (left). This output is sent to 8P pin

connector pin ① (right) and pin ② (left) of CP-90DEX via CP-90REX and recorded via the record amplifier (IC401).

### DESCRIPTION OF NEW CIRCUIT

#### 1. SBBS (Super Bass Boost System) Circuit (CP-90S/CP-900S)

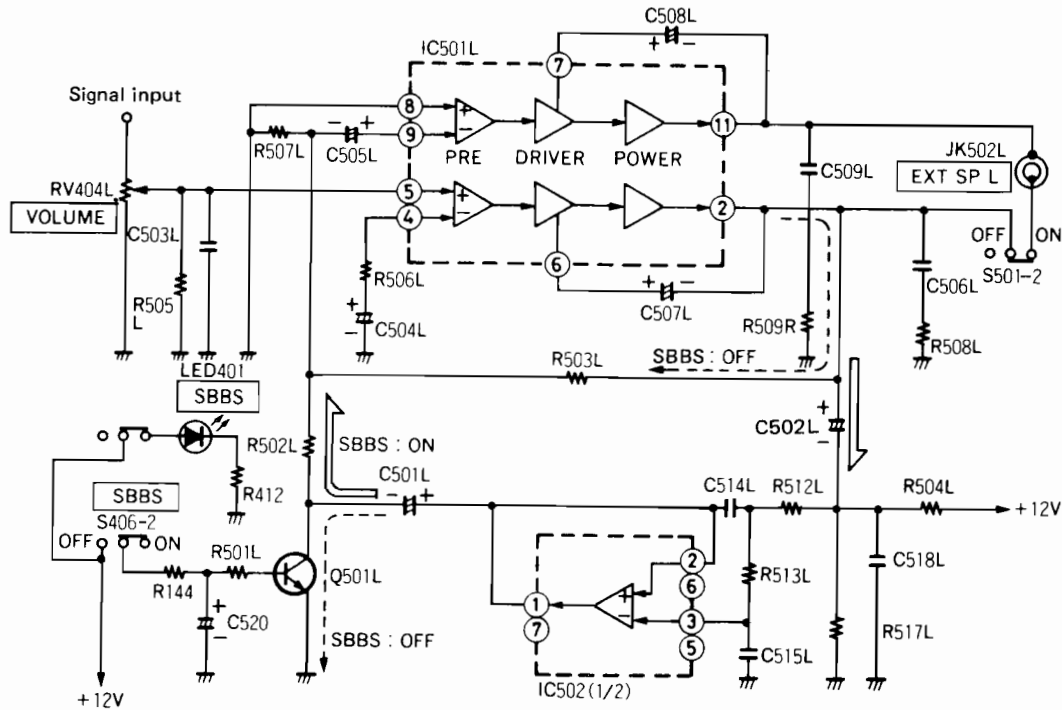

This circuit combines a BTL amplifier and low-pass filter, boosts the super bass frequency band at the minimum resonance frequency  $f_0$  (approx. 140 Hz) or less of the mini-speaker (caliber: 9 cm) and compensates for lack of low frequencies. When the SBBS switch (S406) is set to OFF, the SBBS signal (inversion signal) is applied to GND via Q501L by the activation of the switching transistor (Q501L), so the inversion signal circuit of IC501L (BTL amp) amplifies and outputs the inverted input signal resulting from the feedback resistor (R503L).

When S406 is set to ON, the SBBS indicator (LED401) is lit and at the same time Q501L is set to OFF, so the SBBS signal is fed to the inversion signal circuit of IC501L via C501L. The active low-pass filter composed of R512L, R513L, C514L, C515L and IC502 (1/2) passes frequencies less than the minimum resonance frequency ( $f_0$ ) of the mini-speaker.

The free-edge speaker with the edge made from special rubber is used to improve the effect further and the speaker box which uses a high density compound resin combined with a special inorganic filler to enhance its acoustic characteristics.

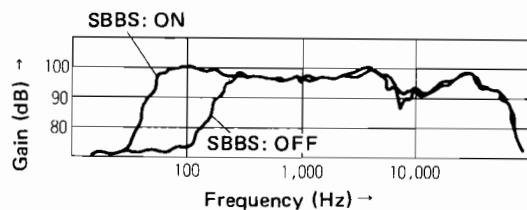



**2. AC-DC combination erase head (CP-90DEX)**

A higher erase ratio is required to record and playback sound with less noise and distortion, so AC erasing with high erase ratio is ideal, but it requires large power, so the DC erase (magnetic erase) is used for the mini-tape recorder. The AC-DC combination erase head used in CP-90DEX is an erase head with combined AC erase and

DC erase (magnetic erase); DC erase is applied by the magnet first and then AC erase is applied. Power is reduced by approx. 60% compared with an AC erase head and at the same time, the erase ratio equivalent to that using an AC erase head can be obtained.

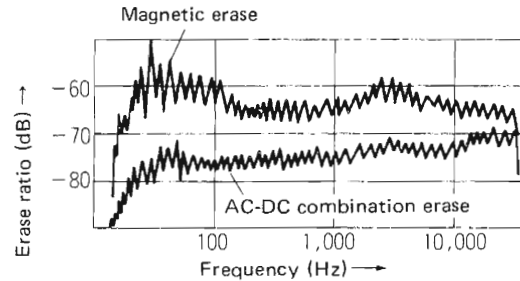
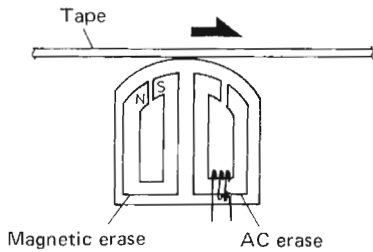

**CAUTIONS ON REPAIRING PRINTED RESISTOR**

**1. Cautions during soldering**

Do not heat the resistor and conductor directly. The resistor and conductor may be broken by heat or the resistance may be changed when the resistor or conductor is heated directly by a soldering iron or when the heat from the soldering iron is conducted via the parts lead.

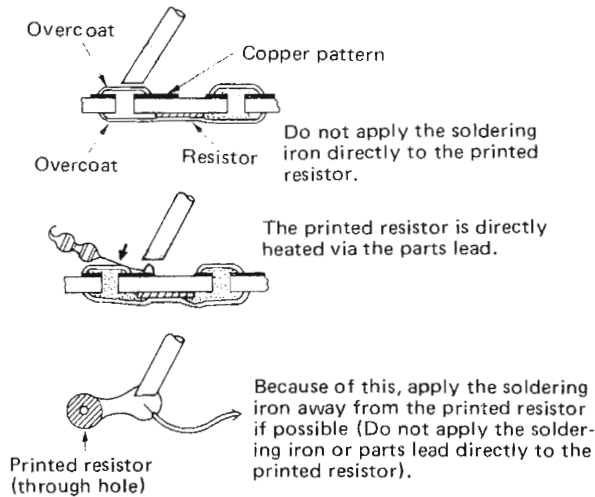

#### 4. How to repair

##### (1) Printed resistor

Check printed resistors and perform the following when they are faulty.

- ① Cut the resistor completely as shown in the diagram. When it is not cut completely, it causes unstable operation or trouble.
- ② Solder a resistor with a resistance equal to that of the printed resistor to the copper pattern to which the printed resistor has been connected as shown in the diagram.

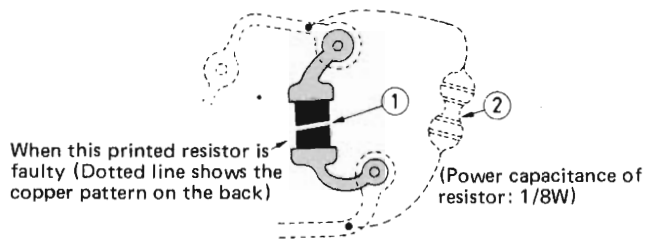

##### (2) Printed pattern

Check the pattern in the way same as the printed resistor. When the printed pattern is disconnected, solder 0.65  $\phi$  plated wire or 7/0.2 solder-plated UL wire to the copper pattern connected to the printed pattern.

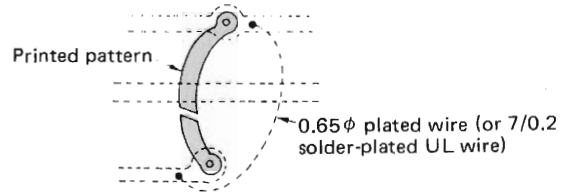

## TUNER

## CP-90TH/CP-90TE/CP-90TW

## KEY TO ILLUSTRATIONS

1. FM STEREO INDICATOR
2. BAND SELECTOR
3. BAND SELECTOR (CP-90TE, CP-90TW ONLY)
4. MODE SWITCH
5. TUNING CONTROL
6. VOLUME CONTROL

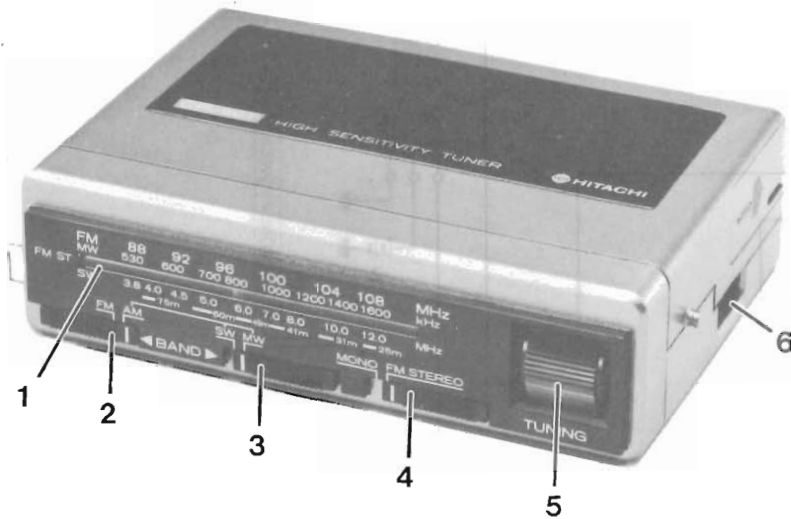

## SPECIFICATIONS

Item		CP-90TH	CP-90TE	CP-90TW
Tuning Range	FM	88 to 108 MHz	87.5 to 108 MHz	88 to 108 MHz
	SW			3.8 to 12 MHz
	AM(MW)		530 to 1605 kHz	
	LW		150 to 285 kHz	
Intermediate Frequency	FM		10.7 MHz	
	AM	455 kHz	468 kHz	455 kHz
Sensitivity	FM		0 dB (Max.), 8 dB (Pra.)	
	SW			42 dB (Max.), 52 dB (Pra.)
	AM(MW)		35 dB (Max.), 48 dB (Pra.)	
	LW		40 dB (Max.), 53 dB (Pra.)	
Antennas	FM		Telescopic antenna (Rack part)	
	AM	Ferrite antenna		
	SW/MW			Ferrite antenna
	MW/LW		Ferrite antenna	
Semiconductors	ICs		4	
	Transistors	3	2	2
	FET		1	
	Diodes		2	
	LED		1	
Power Output		30 mW + 30 mW (T.H.D. 10%)		
Output Impedance		Headphone: 8 ~ 300 $\Omega$		
Power Supply		DC: 3V ("AA" cell or IEC R6 x 2)		
Power Consumption		30 mA (with no signal)		
Dimensions		120(W) x 33.5(H) x 80(D) mm		
Weight		160 g (with batteries)		

BLOCK DIAGRAM

1. CP-90TH

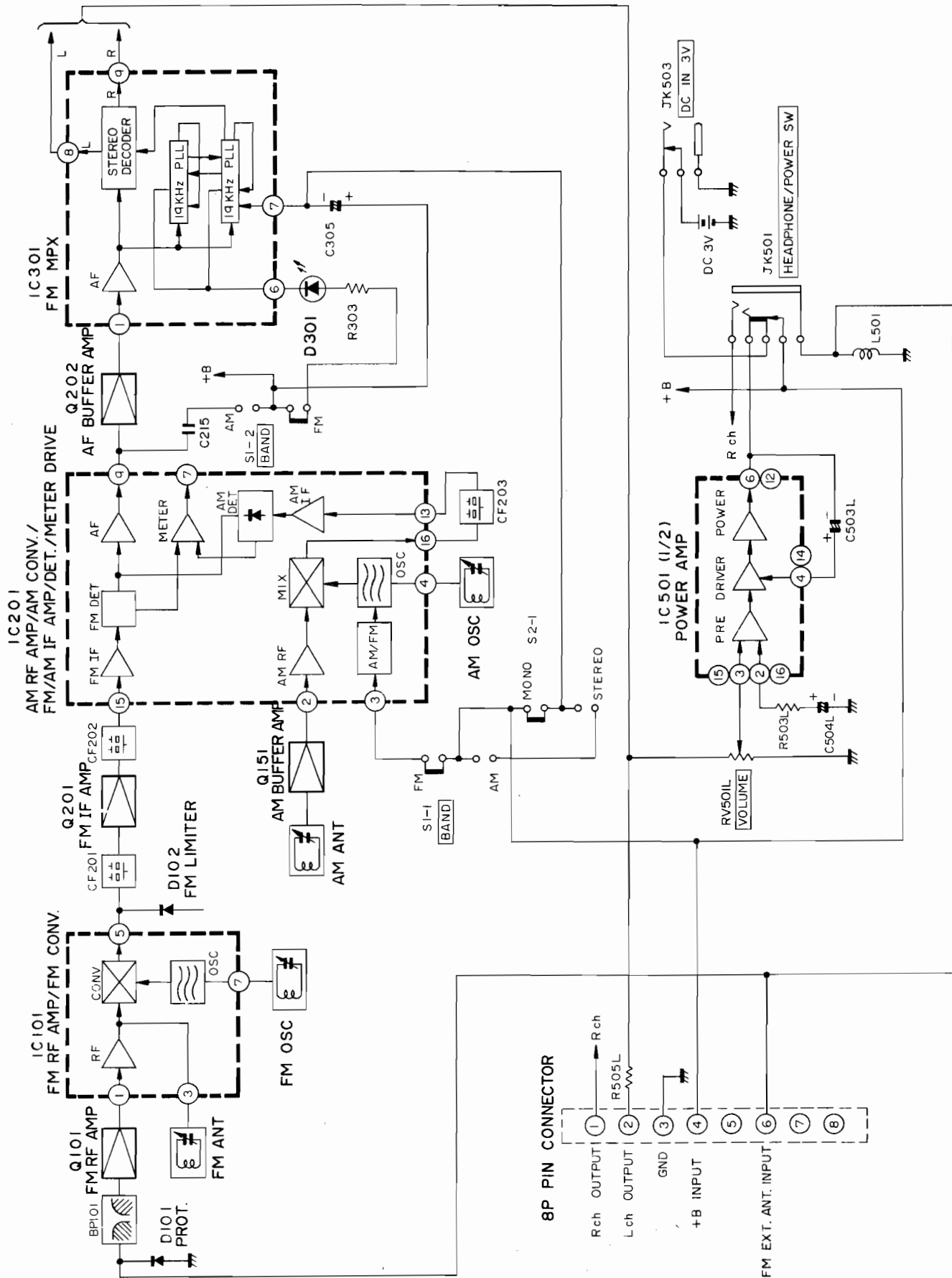

2. CP-90TE/TW

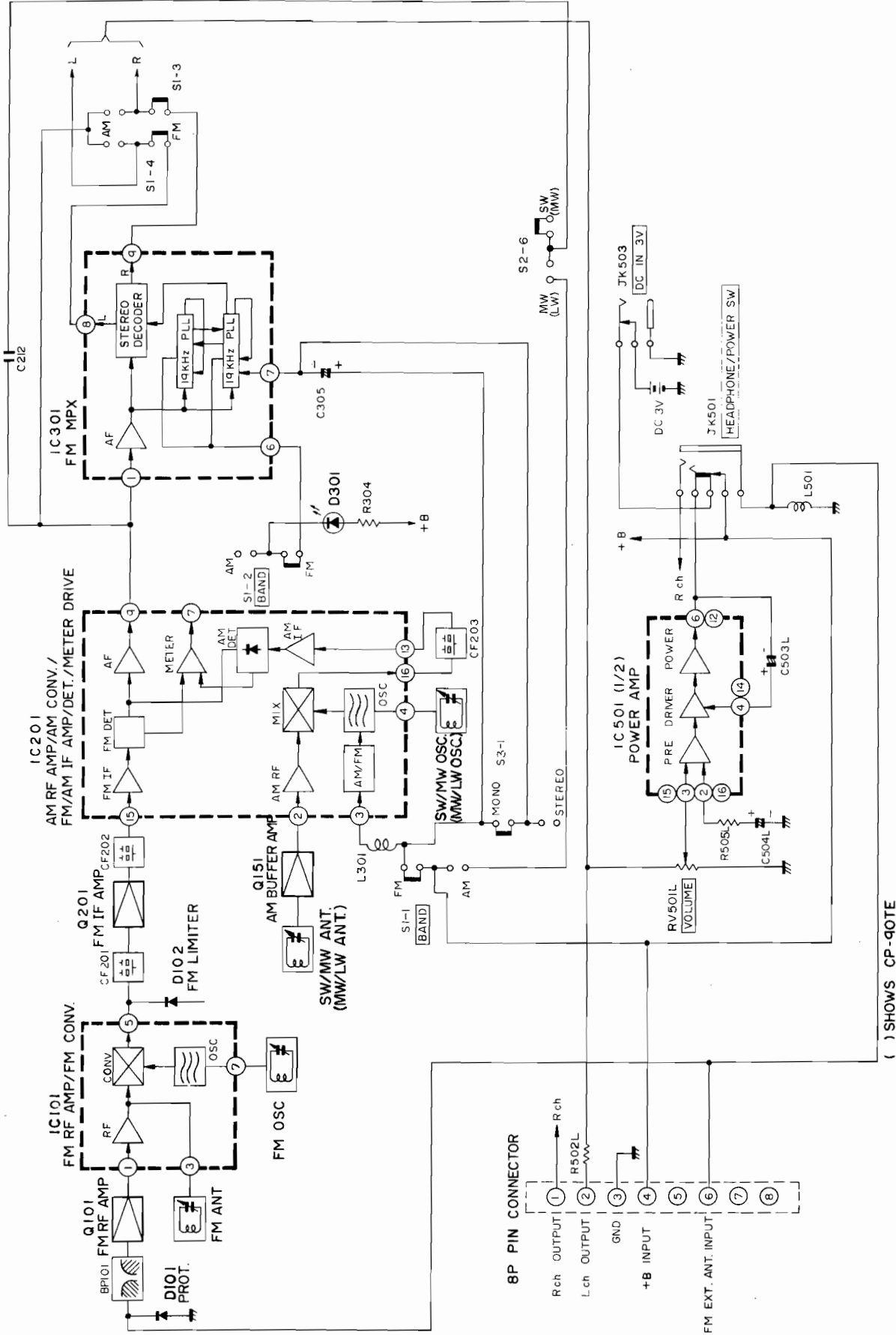

### CONNECTORS

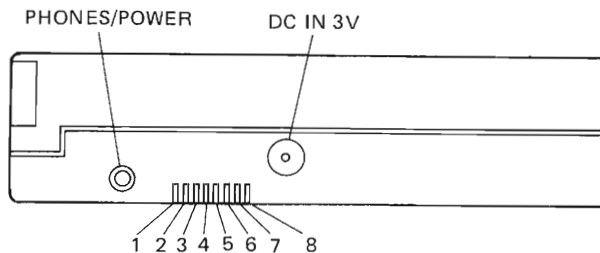

System CP-90S			System CP-900S		
Connector	Terminal	Input/Output	Connector	Terminal	Input/Output
8P pin connector	1	R signal output	Phones/Power		R signal output
	2	L signal output			L signal output
	3	GND	DC IN 3V		FM ANT. input
	4	+3V power input			+3V power input
	5	—	<b>Independently</b>		
	6	FM EXT. ANT. input	Phones/Power		R signal output
	7	—			L signal output
	8	—		FM ANT. input	
				Power switch	
			DC IN 3V		+3V power input

### DISASSEMBLY

#### 1. Escutcheon and Upper Case

1) Remove two\* knobs (Band, Stereo/Mono).

\* three knobs for CP-90TE/TW.

2) Remove (A) (three) screws.

#### 2. Main PC Board

Remove (B) (two) screws.

#### 3. Connector PC Board

Remove (C) (two) screws and unsolder the soldering part.

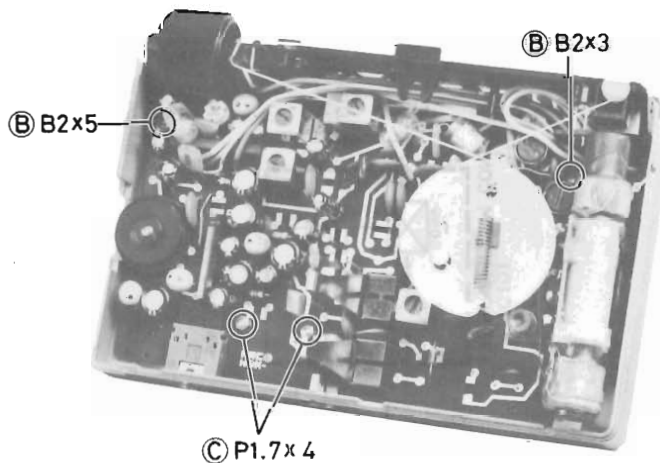
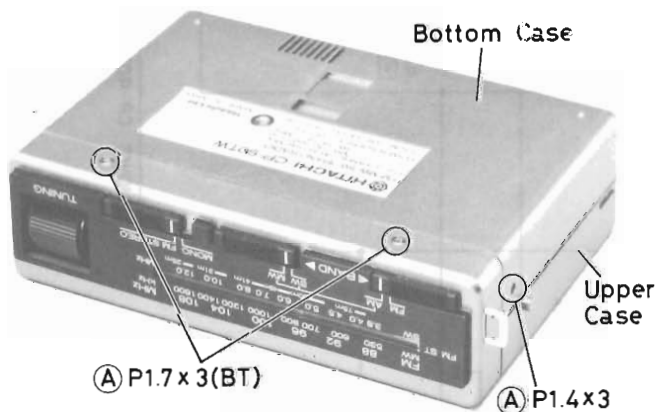

## ADJUSTMENT

## 1. CP-90TH

Step	Adjustment Item	Measuring Instrument and Connection			Genescope or Signal Generator Frequency	Dial Pointer Position	Adjust	Reading
		Measuring Instrument	Input Terminal	Output Terminal				
1	(1) FM IF	Turn T203 fully counterclockwise.						
	(2) S-Curve	• Genescope (10.7 MHz)	TP3	TP4	10.7 MHz	Highest	T201	Note 1
2	(1) FM OSC. (Covering)	• FM signal generator (400Hz 30% mod.) • Oscilloscope • VTVM	TP1, 2 (thru FM dummy antenna) (Note 3)	Headphone socket (8 $\Omega$ load)	87 MHz	Lowest	L102	Output Max.
					109 MHz	Highest	CT102	
	(3)				Repeat steps (1) and (2)			
3	(1) FM ANT. (Tracking)	• Oscilloscope • VTVM	TP1, 2 (thru FM dummy antenna) (Note 3)	Headphone socket (8 $\Omega$ load)	90 MHz	90 MHz	L101	Output Max.
					106 MHz	106 MHz	CT101	
	(3)				Repeat steps (1) and (2)			
4	(1) FM MPX (Multiplex)	• Frequency counter	Connect a 10 $\mu$ F 25V electrolytic capacitor between the No.1 pin of IC301 and ground.	TP5	—	—	RT301	76 kHz $\pm$ 500 Hz (Note 4)
5	(1) AM IF	• Genescope (455 kHz)	Ferrite-core antenna (Note 5)	TP4	455 kHz	Highest	T202 T204	Note 6
					Repeat step (1)			
6	(1) AM OSC. (Covering)	• AM signal generator (400 Hz, 30% mod.) • VTVM	Ferrite-core antenna (Note 5)	Headphone socket (8 $\Omega$ load)	520 kHz	Lowest	L152	Output Max.
					1650 kHz	Highest	CT152	
	(3)				Repeat steps (1) and (2)			
7	(1) AM ANT. (Tracking)	• VTVM	Ferrite-core antenna (Note 5)	Headphone socket (8 $\Omega$ load)	600 kHz	600 kHz	L151	Output Max.
					1400 kHz	1400 kHz	CT151	
	(3)				Repeat steps (1) and (2)			

2. CP-90TE

\* For West Germany

Step	Adjustment Item	Measuring Instrument and Connection			Genescope or Signal Generator Frequency	Dial Pointer Position	Adjust	Reading
		Measuring Instrument	Input Terminal	Output Terminal				
1	(1) FM IF	Turn T203 fully counterclockwise.						
	(2) S-Curve	• Genescope (10.7 MHz)	TP3	TP4	10.7 MHz	Highest	T201 T203	Note 1 Note 2
2	(1) FM OSC. (Covering)	• FM signal generator (400Hz 30% mod.)	TP1, 2 (thru FM dummy antenna) (Note 3)	Headphone socket (8 Ω load)	87 MHz (87.5MHz*)	Lowest	L103	Output Max.
					109 MHz (108MHz*)	Highest	CT102	
					Repeat steps (1) and (2)			
3	(1) FM ANT. (Tracking)	• Oscilloscope • VTVM			90 MHz	90 MHz	L102	Output Max.
					106 MHz	106 MHz	CT101	
					Repeat steps (1) and (2)			
4	(1) FM MPX (Multiplex)	• Frequency counter	Connect a 10 μF 25V electrolytic capacitor between the No.1 pin of IC301 and ground.	TP5	—	—	RT301	76 kHz ± 500 Hz (Note 4)
5	(1) AM IF	• Genescope (468 kHz)	Ferrite-core antenna (Note 5)	TP4	468 kHz	Highest	T202 T204	Note 6
							Repeat step (1)	
6	(1) LW OSC. (Covering)	• AM signal generator (400Hz, 30% mod.)	Ferrite-core antenna (Note 5)	Headphone socket (8 Ω load)	145 kHz	Lowest	L155	Output Max.
					295 kHz	Highest	CT153	
					Repeat steps (1) and (2)			
7	(1) LW ANT. (Tracking)	• VTVM			160 kHz	160 kHz	L153	Output Max.
					260 kHz	260 kHz	CT152	
					Repeat steps (1) and (2)			
8	(1) MW OSC. (Covering)	• AM signal generator (400Hz, 30% mod.)	Ferrite-core antenna (Note 5)	Headphone socket (8 Ω load)	520 kHz	Lowest	L156	Output Max.
					1650 kHz	Highest	CT154	
					Repeat steps (1) and (2)			
9	(1) MW ANT. (Tracking)	• VTVM			600 kHz	600 kHz	L151	Output Max.
					1400 kHz	1400 kHz	CT151	
					Repeat steps (1) and (2)			



## 3. CP-90TW

Step	Adjustment Item	Measuring Instrument and Connection			Genescope or Signal Generator Frequency	Dial Pointer Position	Adjust	Reading
		Measuring Instrument	Input Terminal	Output Terminal				
1	(1) FM IF	Turn T203 fully counterclockwise.						
	(2) S-Curve	• Genescope (10.7 MHz)	TP3	TP4	10.7 MHz	Highest	T201	Note 1
2	(1) FM OSC. (Covering)	• FM signal generator (400Hz 30% mod.)	TP1, 2 (thru FM dummy antenna) (Note 3)	Headphone socket (8 $\Omega$ load)	87 MHz	Lowest	L103	Output Max.
					109 MHz	Highest	CT102	
					Repeat steps (1) and (2)			
3	(1) FM ANT. (Tracking)	• Oscilloscope • VTVM	TP1, 2 (thru FM dummy antenna) (Note 3)	Headphone socket (8 $\Omega$ load)	90 MHz	90 MHz	L102	Output Max.
					106 MHz	106 MHz	CT101	
					Repeat steps (1) and (2)			
4	(1) FM MPX (Multiplex)	• Frequency counter	Connect a 10 $\mu$ F 25V electrolytic capacitor between the No.1 pin of IC301 and ground.	TP5	—	—	RT301	76 kHz $\pm$ 500 Hz (Note 4)
5	(1) AM IF	• Genescope (455 kHz)	Ferrite-core antenna (Note 5)	TP4	455 kHz	Highest	T202 T204	Note 6
					Repeat step (1)			
6	(1) MW OSC. (Covering)	• AM signal generator (400Hz, 30% mod.)	Ferrite-core antenna (Note 5)	Headphone socket (8 $\Omega$ load)	520 kHz	Lowest	L155	Output Max.
					1650 kHz	Highest	CT153	
					Repeat steps (1) and (2)			
7	(1) MW ANT. (Tracking)	• VTVM	Ferrite-core antenna (Note 5)	Headphone socket (8 $\Omega$ load)	600 kHz	600 kHz	L153	Output Max.
					1400 kHz	1400 kHz	CT152	
					Repeat steps (1) and (2)			
8	(1) SW OSC. (Covering)	• AM signal generator (400Hz, 30% mod.)	Ferrite-core antenna (Note 5)	Headphone socket (8 $\Omega$ load)	3.7 MHz	Lowest	L156	Output Max.
					12.5 MHz	Highest	CT154	
					Repeat steps (1) and (2)			
9	(1) SW ANT. (Tracking)	• VTVM	Ferrite-core antenna (Note 5)	Headphone socket (8 $\Omega$ load)	4.0 MHz	4.0 MHz	L151	Output Max.
					11.0 MHz	11.0 MHz	CT151	
					Repeat steps (1) and (2)			

**Note:**

1. Feed in a weak signal to TP3 from the genescope. Adjust T201 for maximum gain and the waveform shown in Figure 1. If the center of the waveform cannot be lined up on the marker, adjust the right/left balance.

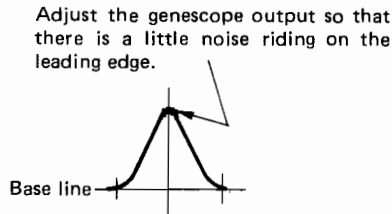

Fig. 1

2. Use the T203 core to form the S-curve shown in Figure 2. Adjust the symmetry of A and B about point C for linearity.

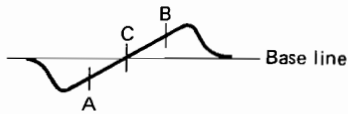

Fig. 2

3. FM dummy antenna shows Figure 3.

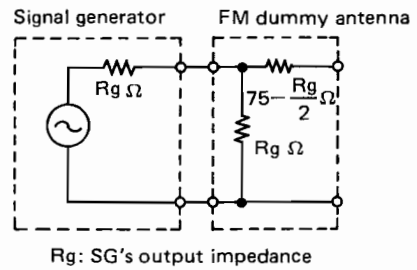

Fig. 3

4. Connect the frequency counter to TP5, via a resistor of 220 kΩ.
5. Connect AM signal generator to loop antenna, bring near to ferrite antenna.
6. Feed in a weak signal from the genescope. Adjust T202 and T204 for maximum gain and the waveform of Figure 4.

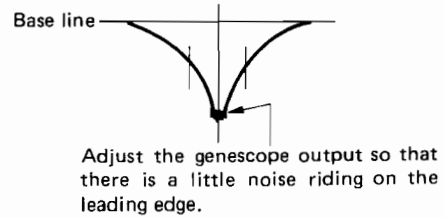
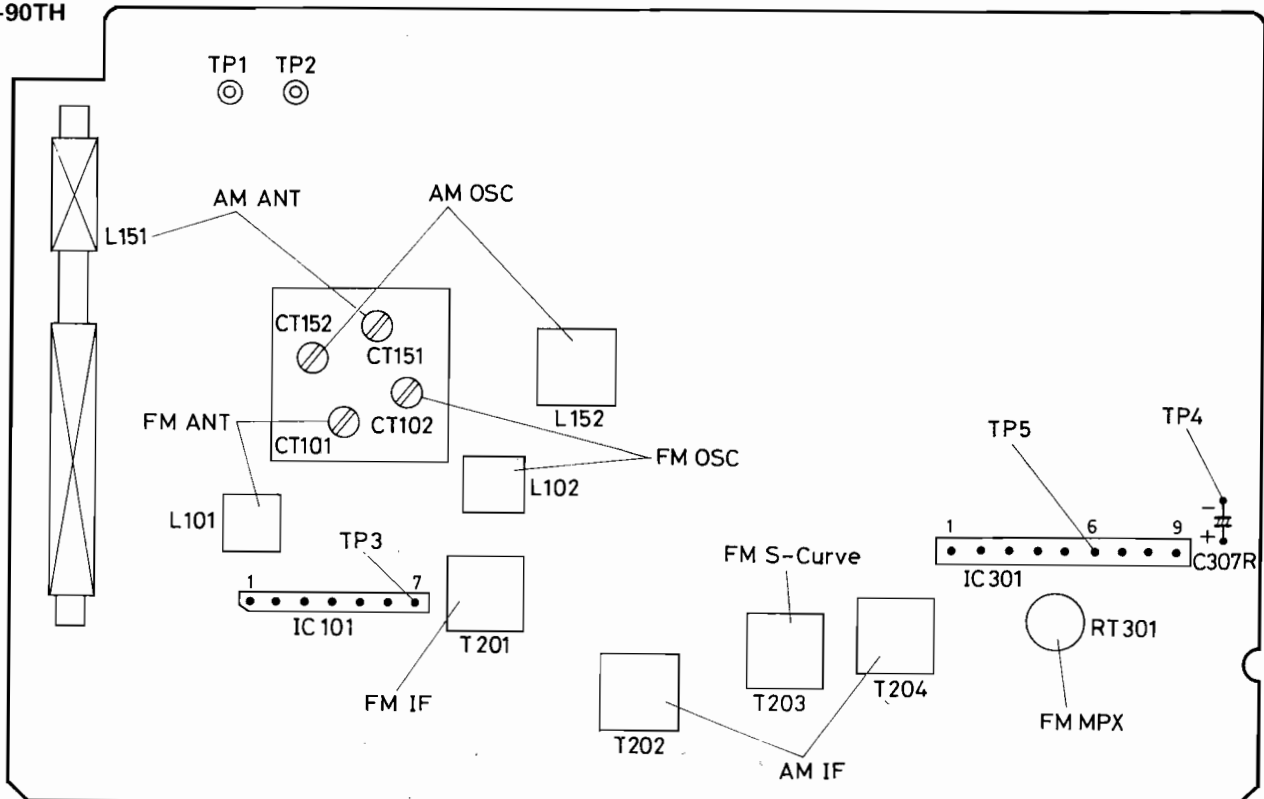

Fig. 4

**ADJUSTMENT PARTS LOCATION**

1. CP-90TH



2. CP-90TE/TW

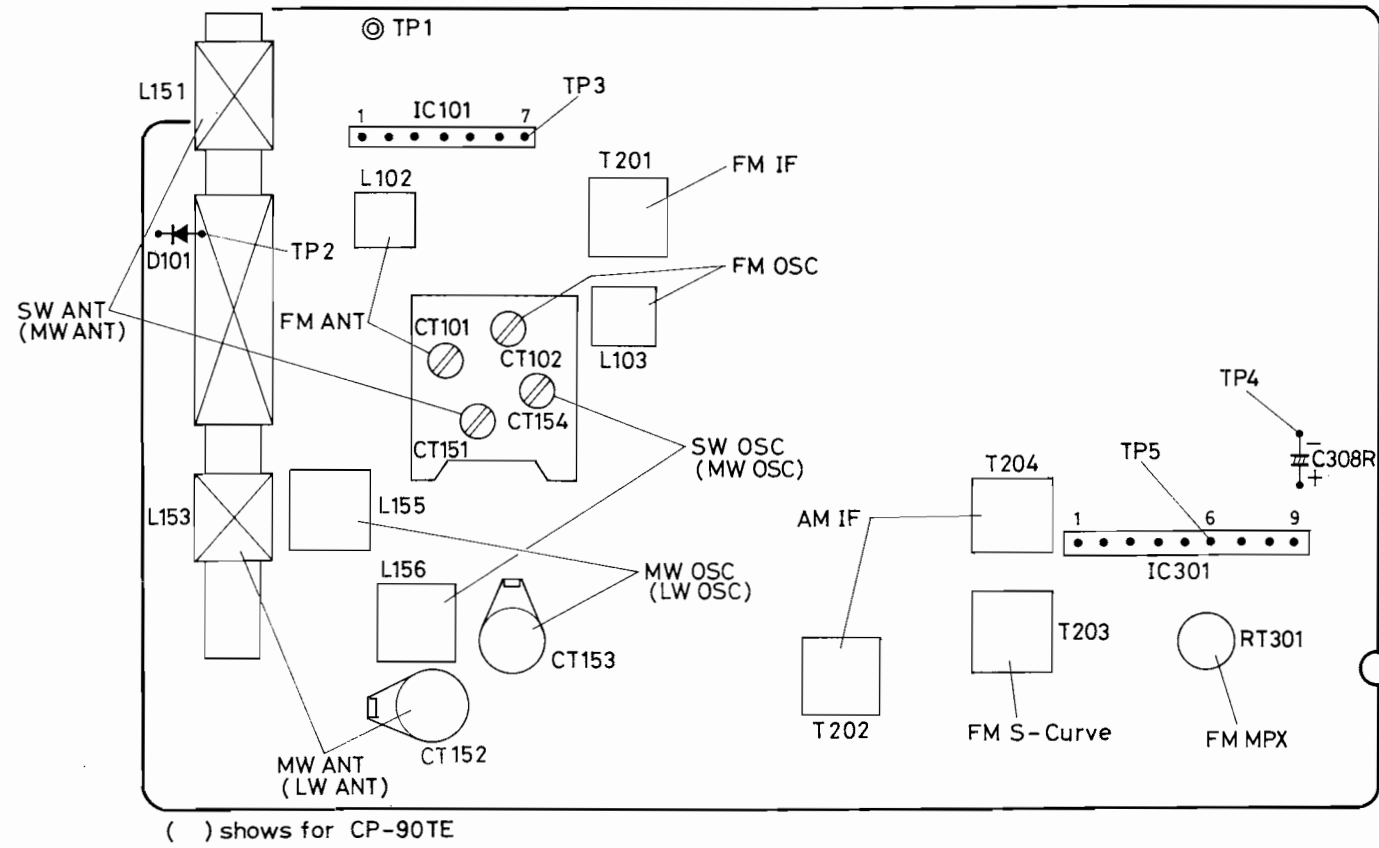

DIAL CORD STRINGING

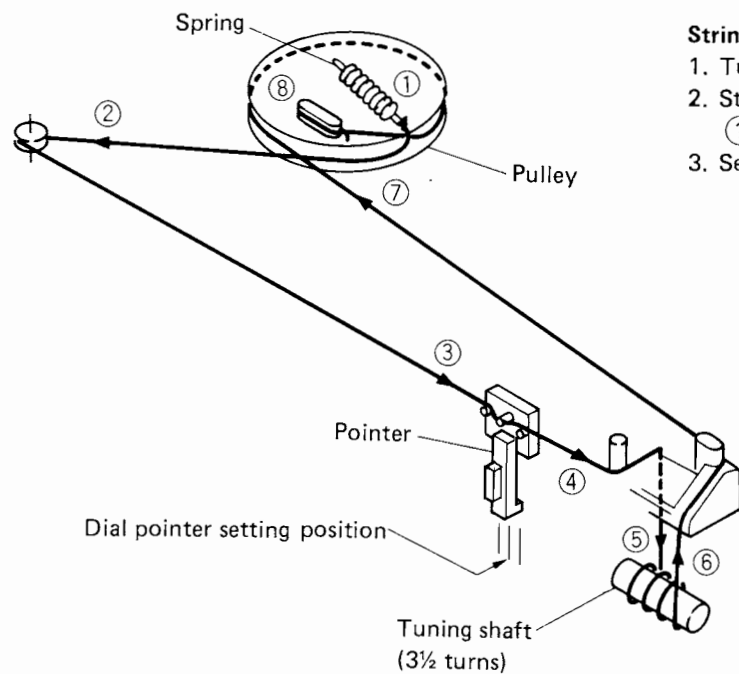

Stringing Method

1. Turn the pulley fully clockwise.
2. String the dial cord in the direction of the arrow (Nos. ① - ⑧).
3. Set the pointer to the setting position.

EXPLODED VIEW

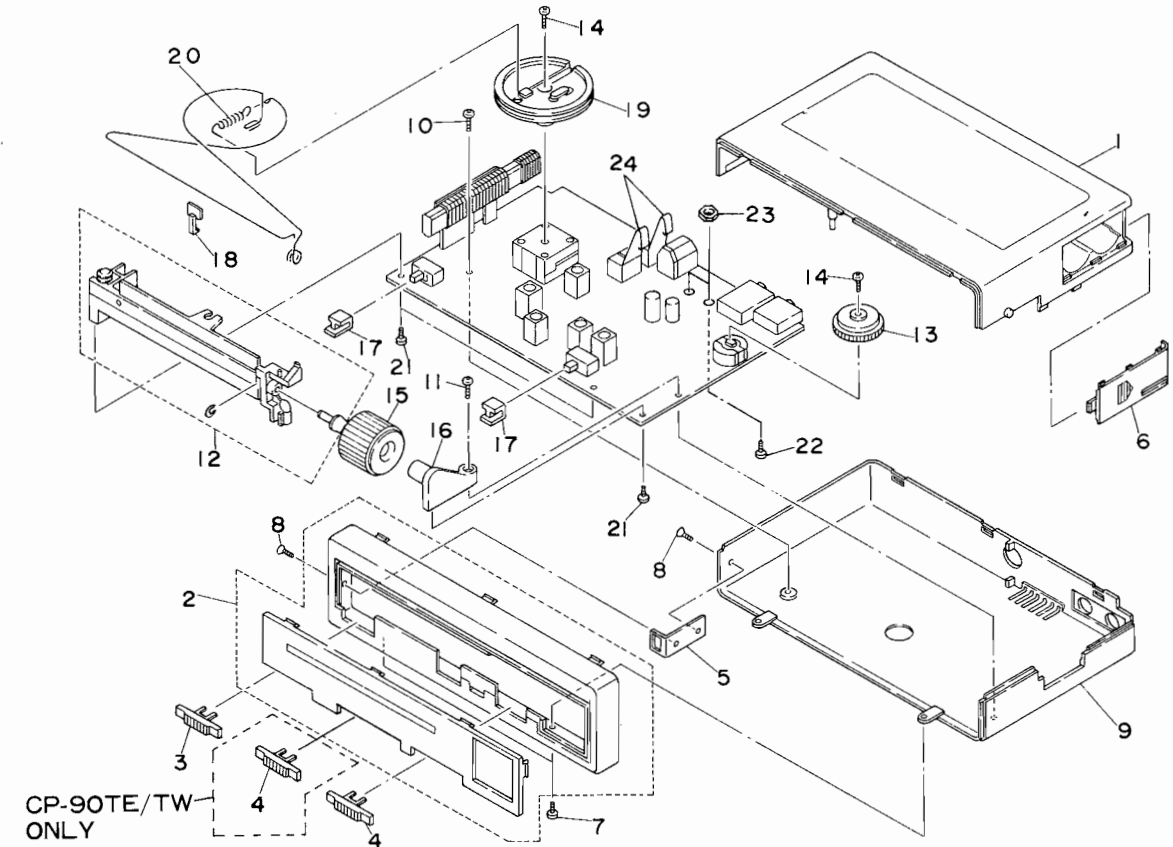

Note: Components marked without numbers in this drawing are not specified as replacement parts.

REPLACEMENT PARTS LIST

SYMBOL-NO	P-NO	DESCRIPTION	SYMBOL-NO	P-NO	DESCRIPTION
MISCELLANEOUS					
1	6038002	UPPER CASE ASSEMBLY	11	8741105	BIND SCREW-2MMD x 5MM
2	6244892	FRONT PANEL ASSEMBLY [CP-90TW]	12	6775001	CHASSIS ASSEMBLY
2	6244893	FRONT PANEL ASSEMBLY [CP-90TE]	13	6292492	VOLUME KNOB
2	6244894	FRONT PANEL ASSEMBLY [CP-90TH]	14	7780901	PAN HEAD SCREW-1.7MMDx4MM
3	6293453	SLIDE KNOB (BAND)	15	6285841	TUNING KNOB
4	6293451	SLIDE KNOB	16	6774981	BEARING
5	7351861	STRAP	17	6774991	JOINT SHAFT
6	6174481	BATTERY LID ASSEMBLY	18	6774931	POINTER
7	8612001	BT PAN HEAD SCREW-1.7MMDx3MM	19	6423101	PULLEY [CP-90TH]
8	8712004	PAN HEAD SCREW-1.4MMDx3MM	19	6423102	PULLEY [CP-90TE/CP-90TW]
9	6037992	UNDER CASE ASSEMBLY [CP-90TW]	20	6316232	SPRING M
9	6037993	UNDER CASE ASSEMBLY [CP-90TE]	21	8612003	BT PAN HEAD SCREW-1.7MMDx5MM
9	6037994	UNDER CASE ASSEMBLY [CP-90TH]	22	7780901	PAN HEAD SCREW-1.7MMDx4MM
10	8741103	BIND SCREW-2MMD x 3MM	23	7772472	NUT-1.7MMD
			24	7451581	BATTERY TERMINAL

SCHMATIC DIAGRAM (CP-90TH)

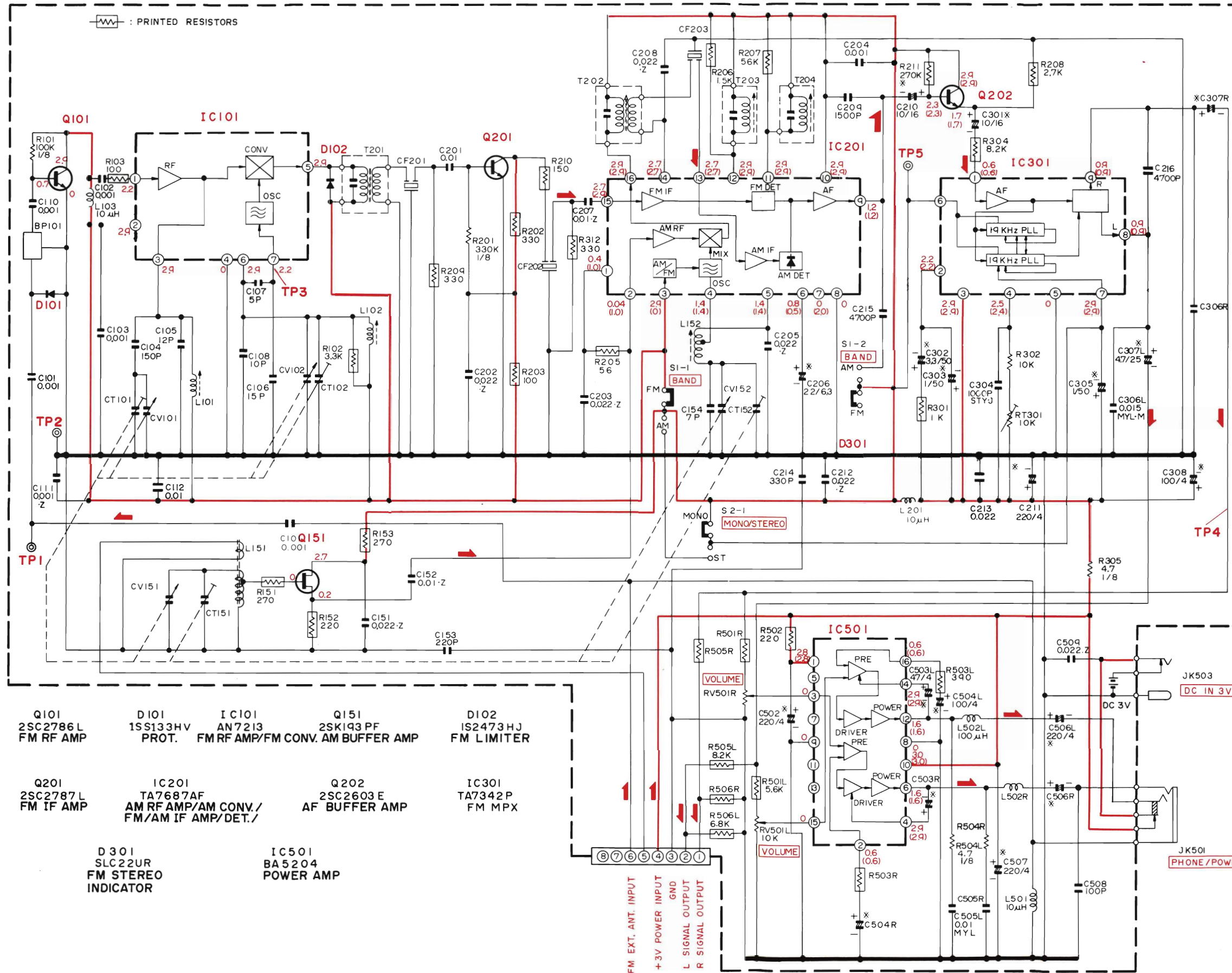

- Q101 2SC2786 L FM RF AMP
- D101 1SS133HV PROT.
- IC101 AN7213 FM RF AMP/FM CONV. AM BUFFER AMP
- Q151 2SK143 PF AM BUFFER AMP
- D102 IS2473 HJ FM LIMITER
- Q201 2SC2787 L FM IF AMP
- IC201 TA7687AF AM RF AMP/AM CONV./FM/AM IF AMP/DET./
- Q202 2SC2603 E AF BUFFER AMP
- IC301 TA7342 P FM MPX
- D301 SLC22UR FM STEREO INDICATOR
- IC501 BA5204 POWER AMP

Note

1. Voltage measured at base of chassis with minimum volume control and no signal.
  2. Nomenclature of Resistors and Capacitors.
- | Circuit No. |   |
|-------------|---|
| Value       | No indicated Ω(Ohm)<br>M : 1000 kΩ  |
| Tolerance   | No indicated ±5%<br>K : ±10%<br>M : ±20%  |
| Wattage     | No indicated ¼W   |
| Sort        | No indicated Carbon film<br>RC : Composition<br>RW : Wire wound<br>RS : Oxide metal film<br>RN : Fixed metal film |
- 
- | Circuit No. |  |
|-------------|--|
| Value       | No indicated μF<br>P : PF  |
| Tolerance   | No indicated ±10%<br>J : ±5%<br>M : ±20%<br>Z : +80% -20%<br>D : ±0.5pF<br>C : ±0.25pF |
| Sort        | Ceramic<br>Electrolytic<br>Mylar<br>Polyester<br>Styrol                                |
| Voltage     | No indicated 50WV  |

3. Be sure to make your orders of resistors and capacitors with value, voltage, tolerance and sort.
4. When replacing capacitors marked with \*, use specified ones stated on parts list since required temperature characteristics.

CIRCUIT BOARD DIAGRAM (CP-90TH)

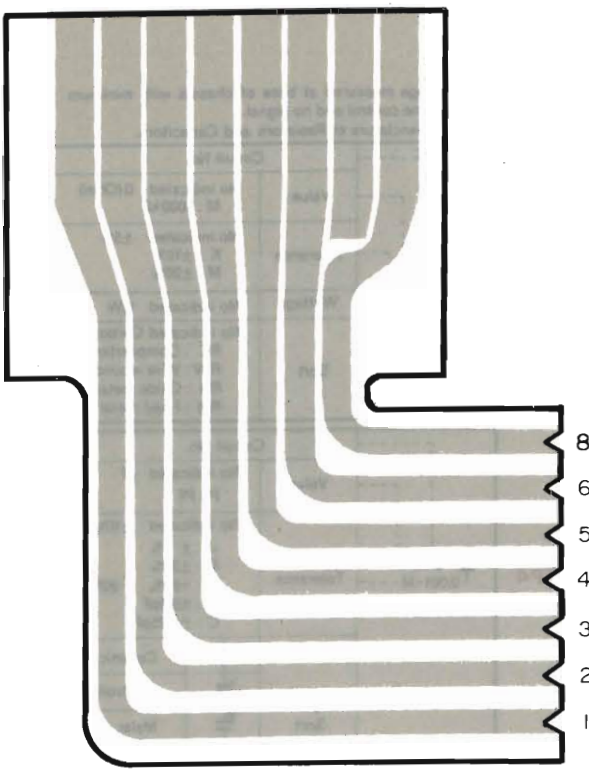

CONNECTOR

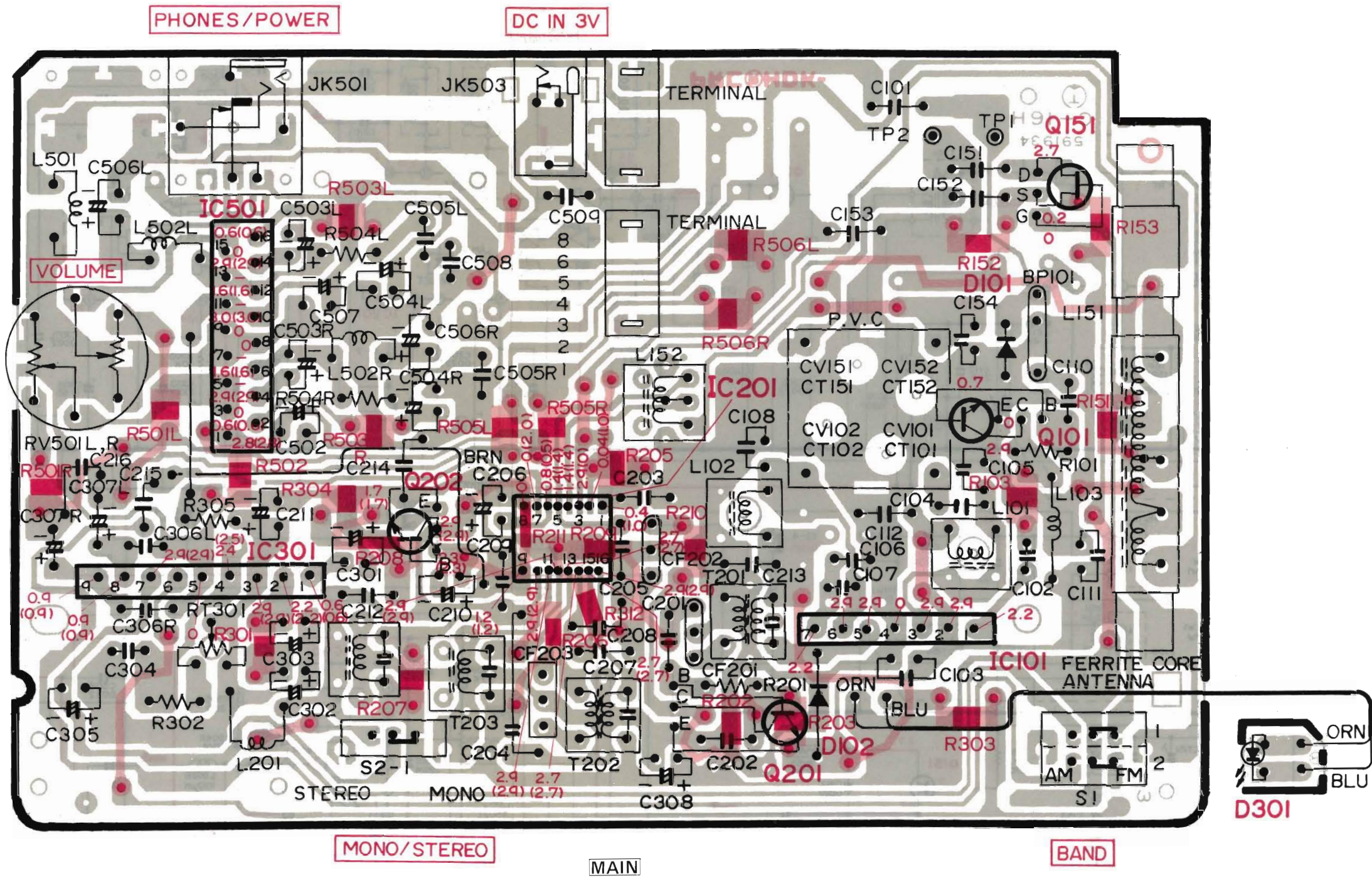

SCHMATIC DIAGRAM (CP-90TE/CP-90TW)

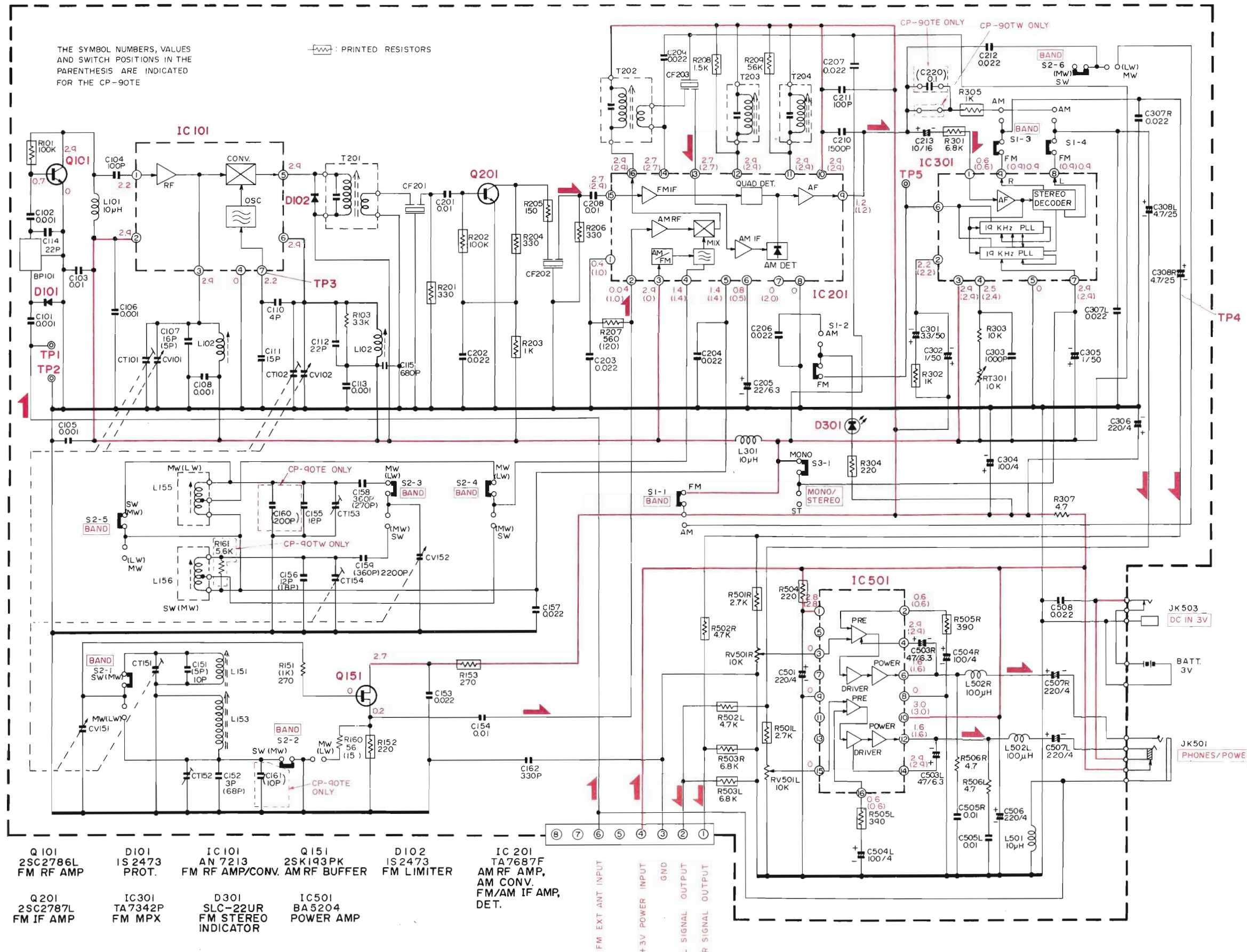

Note

1. Voltage measured at base of chassis with minimum volume control and no signal.
2. Nomenclature of Resistors and Capacitors.

Circuit No.	
Value	No indicated Ω(Ohm) M : 1000 kΩ
Tolerance	No indicated ±5% K : ±10% M : ±20%
Wattage	No indicated ¼W
Sort	No indicated Carbon film RC : Composition RW : Wire wound RS : Oxide metal film RN : Fixed metal film

Circuit No.	
Value	No indicated μF P : PF
Tolerance	No indicated ±10% J : ±5% M : ±20% Z : +80%, -20% D : ±0.5pF C : ±0.25pF
Sort	Ceramic Electrolytic Mylar Polyester Styrol
Voltage	No indicated 50WV

3. Be sure to make your orders of resistors and capacitors with value, voltage, tolerance and sort.
4. When replacing capacitors marked with \*, use specified ones stated on parts list since required temperature characteristics.

CIRCUIT BOARD DIAGRAM (CP-90TE/CP-90TW)

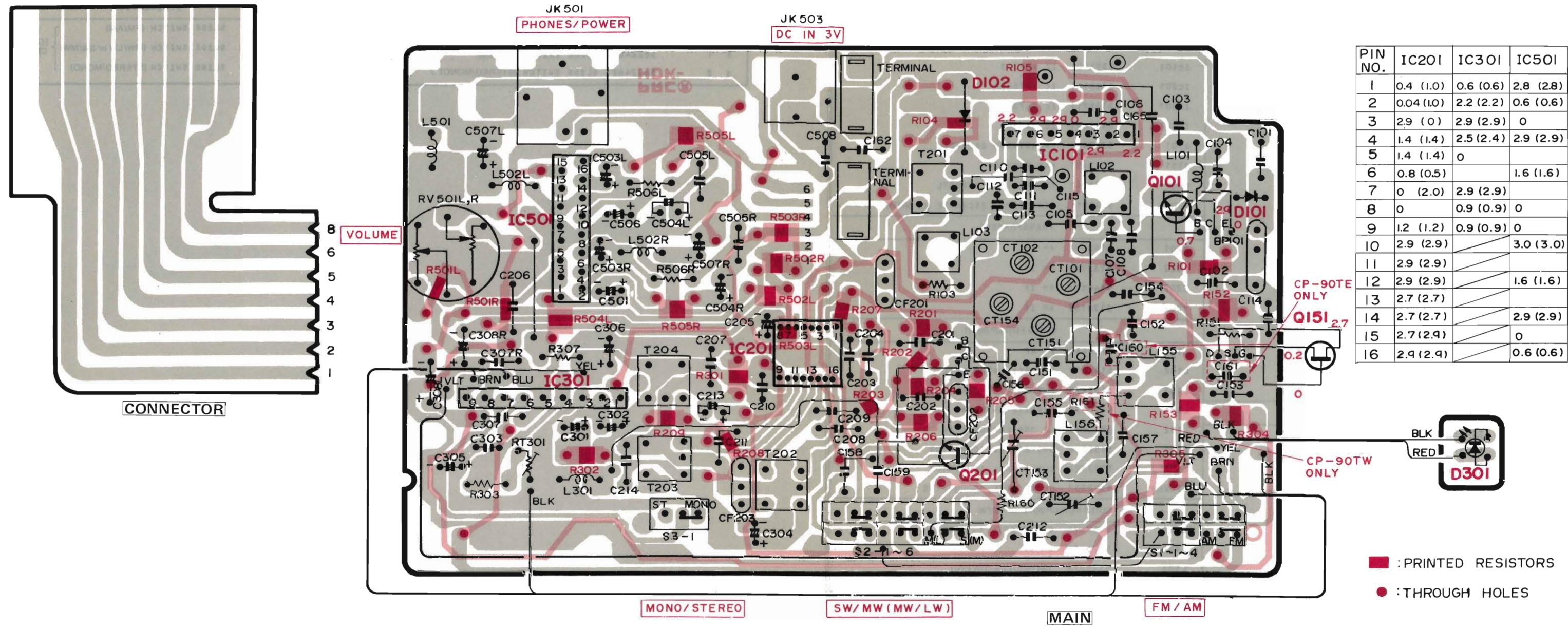

PIN NO.	IC201	IC301	IC501
1	0.4 (1.0)	0.6 (0.6)	2.8 (2.8)
2	0.04 (1.0)	2.2 (2.2)	0.6 (0.6)
3	2.9 (0)	2.9 (2.9)	0
4	1.4 (1.4)	2.5 (2.4)	2.9 (2.9)
5	1.4 (1.4)	0	
6	0.8 (0.5)		1.6 (1.6)
7	0 (2.0)	2.9 (2.9)	
8	0	0.9 (0.9)	0
9	1.2 (1.2)	0.9 (0.9)	0
10	2.9 (2.9)		3.0 (3.0)
11	2.9 (2.9)		
12	2.9 (2.9)		1.6 (1.6)
13	2.7 (2.7)		
14	2.7 (2.7)		2.9 (2.9)
15	2.7 (2.4)		0
16	2.4 (2.4)		0.6 (0.6)

## REPLACEMENT PARTS LIST

SYMBOL-NO	P-NO	DESCRIPTION	SYMBOL-NO	P-NO	DESCRIPTION
CAPACITORS FOR CP-90TH					
CT101-102	5052821	VARIABLE CAPACITOR	D101-102	5330574	DIODE SILICON 1S2473HC [CP-90TE/CP-90TW]
CT151-152	5052821	VARIABLE CAPACITOR	D301	5380621	LED SLC-22UR
CV101-102	5052821	VARIABLE CAPACITOR	IC101	5351901	IC AN7213
CV151-152	5052821	VARIABLE CAPACITOR	IC201	5368141	IC TA7687F
C206	0256161	ELECTROLYTIC 22MF 6.3V	IC301	5355711	IC TA7342P
C210	0256155	ELECTROLYTIC 10UF 16V	IC501	5355691	IC BA5204
C211	0256162	ELECTROLYTIC 220MF 4V	Q101	5323451	TRANSISTOR 2SC2786L
C301	0256155	ELECTROLYTIC 10UF 16V	Q151	5323431	FET 2SK193PK
C302	0256153	ELECTROLYTIC 3.3UF 50V	Q201	5323441	TRANSISTOR 2SC2787L
C303	0256151	ELECTROLYTIC 1.0UF 50V	Q202	5323011	TRANSISTOR 2SC2603E [CP-90TH]
C305	0256151	ELECTROLYTIC 1.0UF 50V	TRANSFORMERS		
C307LR	0256154	ELECTROLYTIC 4.7UF 25V	T201	5140071	FM IF
C308	0256167	ELECTROLYTIC 100MF 4V	T202	5130128	AM IF
C502	0256162	ELECTROLYTIC 220MF 4V	T203	5148113	FM IF
C503LR	0256166	ELECTROLYTIC 47MF 4V	T204	5130129	AM IF
C504LR	0256167	ELECTROLYTIC 100MF 4V	COILS FOR CP-90TH		
C506LR	0256162	ELECTROLYTIC 220MF 4V	L101	5126482	FM RF
C507	0256162	ELECTROLYTIC 220MF 4V	L102	5126312	FM OSCILLATOR COIL
CAPACITORS FOR CP-90TE/CP-90TW					
CT101-102	5052831	VARIABLE CAPACITOR	L103	5152475	CHOKE COIL 10 MICRO H
CT151	5052831	VARIABLE CAPACITOR	L151	5110571	FERRITE ANTENNA
CT152	5058091	TRIMMER CAPACITOR 8PF	L152	5120685	AM OSCILLATOR COIL
CT153	5058091	TRIMMER CAPACITOR 8PF [CP-90TW]	L201	5152324	CHOKE COIL 10UH+-10%
CT153	5058104	TRIMMER 50PF [CP-90TE]	L501	5152324	CHOKE COIL 10UH+-10%
CT154	5052831	VARIABLE CAPACITOR	L502LR	5152337	CHOKE COIL 100UH+-10%
CV101-102	5052831	VARIABLE CAPACITOR	COILS FOR CP-90TE/CP-90TW		
CV151-152	5052831	VARIABLE CAPACITOR	L101	5152475	CHOKE COIL 10 MICRO H
C205	0256161	ELECTROLYTIC 22MF 6.3V	L102	5126482	FM RF
C301	0256153	ELECTROLYTIC 3.3UF 50V	L103	5126278	FM OSCILLATOR COIL
C302	0256151	ELECTROLYTIC 1.0UF 50V	L151	5113751	FERRITE ANTENNA [CP-90TW]
C304	0256167	ELECTROLYTIC 100MF 4V	L151	5113752	FERRITE ANTENNA [CP-90TE]
C305	0256151	ELECTROLYTIC 1.0UF 50V	L155	5140236	MW OSCILLATOR COIL [CP-90TW]
C306	0256162	ELECTROLYTIC 220MF 4V	L155	5140237	LW OSCILLATOR COIL [CP-90TE]
C308LR	0256154	ELECTROLYTIC 4.7UF 25V	L156	5140235	SW OSCILLATOR COIL [CP-90TW]
C501	0256162	ELECTROLYTIC 220MF 4V	L156	5140236	MW OSCILLATOR COIL [CP-90TE]
C503LR	0256166	ELECTROLYTIC 47MF 4V	L301	5152324	CHOKE COIL 10UH+-10%
C504LR	0256167	ELECTROLYTIC 100MF 4V	L501	5152324	CHOKE COIL 10UH+-10%
C506	0256162	ELECTROLYTIC 220MF 4V	L502LR	5152337	CHOKE COIL 100UH+-10%
C507LR	0256162	ELECTROLYTIC 220MF 4V	MISCELLANEOUS		
RESISTORS					
RT301	5007435	SEMI VARIABLE 10KOHM	5951312	CONNECTOR P.W.B	
RV501LR	5008821	VARIABLE RESISTOR 10KOHM(A)	BP101	5162511	BAND PASS FILTER
SEMI-CONDUCTORS					
D101	5331591	DIODE 1S5133HV } [CP-90TH]	CF201-202	5160301	CERAMIC FILTER 10.7MHZ
D102	5330574	DIODE 1S2473 }	CF203	5160084	CERAMIC FILTER 455KHZ [CP-90TH/CP-90TW]
			CF203	5160201	CERAMIC FILTER 468KHZ [CP-90TE]
			JK501	5673492	JACK-3.5MMD
			JK503	5672091	DC JACK

SYMBOL-NO	P-NO	DESCRIPTION	SYMBOL-NO	P-NO	DESCRIPTION
MISCELLANEOUS					
S 1	5622461	SLIDE SWITCH (FM/AM)	S 1	5622591	SLIDE SWITCH (FM/AM)
S 2	5622462	SLIDE SWITCH (STEREO/MONO) } [CP-90TH]	S 2	5622592	SLIDE SWITCH (MW/LW or SW/MW) } [CP-90TE/CP-90TW]
			S 3	5622462	SLIDE SWITCH (STEREO/MONO) }



**STEREO AMPLIFIER  
SYSTEM RACK  
SPEAKER**

**CP-90S/CP-900S  
CP-90REX  
CP-90SP**

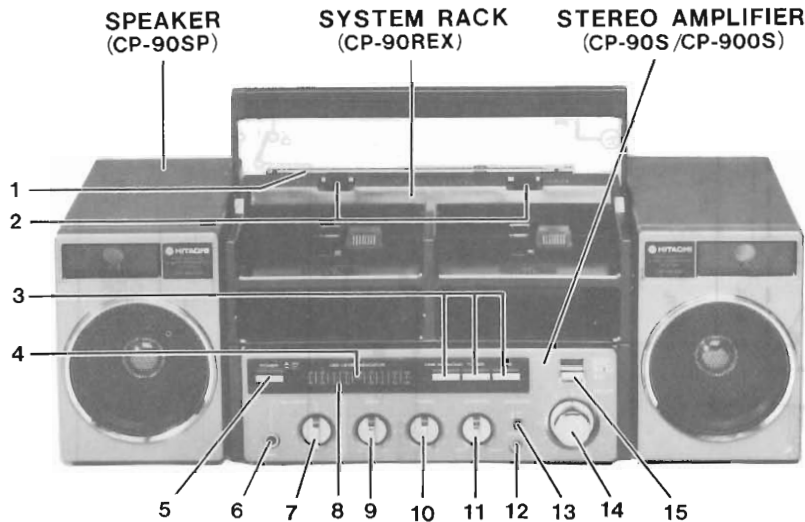

**KEY TO ILLUSTRATIONS**

1. TELESCOPIC ANTENNA
2. RELEASE BUTTONS
3. FUNCTION SELECTORS
4. OPERATION INDICATOR [FOR H, HC, AU, W, EW]
4. AC POWER INDICATOR [FOR E, EZ, E(BS)]
5. POWER SWITCH [FOR H, HC, AU, W, EW]
5. OPERATE SWITCH [FOR E, EZ, E(BS)]
6. MIC MIXING SOCKET
7. MIC MIXING VOLUME CONTROL
8. LED LEVEL INDICATORS
9. BASS CONTROL
10. TREBLE CONTROL
11. BALANCE CONTROL
12. HEADPHONE SOCKET
13. SPEAKER SWITCH
14. VOLUME CONTROL
15. SBBS SWITCH

**SPECIFICATIONS**

Semiconductors:	ICs: 8 Transistors: 10 Diodes: 7 LEDs: 2	AC: 220V, 50Hz, (For E, EZ) 240V, 50Hz [For E(BS), AU] DC: 15V (Use car battery adaptor)
Input Sensitivity and Impedance:	Mix. Mic.: 0.3 mV, 3.3K ohms Line in: 450 mV, 50K ohms Phono in: 6 mV, 50K ohms	Power Consumption: 35W (For H, HC) 54W [For E, EZ, E(BS)] 38W (For W, EW, AU)
Output Level and Load Impedance:	Line out: 775 mV, 1K ohms Headphone: 8 to 300 ohms Ext. Speaker: 6 to 8 ohms	Dimensions: Amplifier: 276(W) x 83(H) x 201(D) mm System Rack: 276(W) x 88(H) x 168(D) mm Speaker: 112(W) x 163(H) x 164(D) mm
Power Output: Speakers:	12W/CH (T.H.D. 10%) 9 cm, 6 ohms x 2 2 cm ceramic tweeter x 2	Weight: Amplifier: 2.8 kg System Rack: 1.2 kg Speaker: 1.5 kg x 2
Power Supply:	AC: 110-127V/200-220V/ 230-250V, 50/60 Hz [For H, HC, W, EW]	

BLOCK DIAGRAM

Stereo Amplifier (CP-90S/CP-900S)

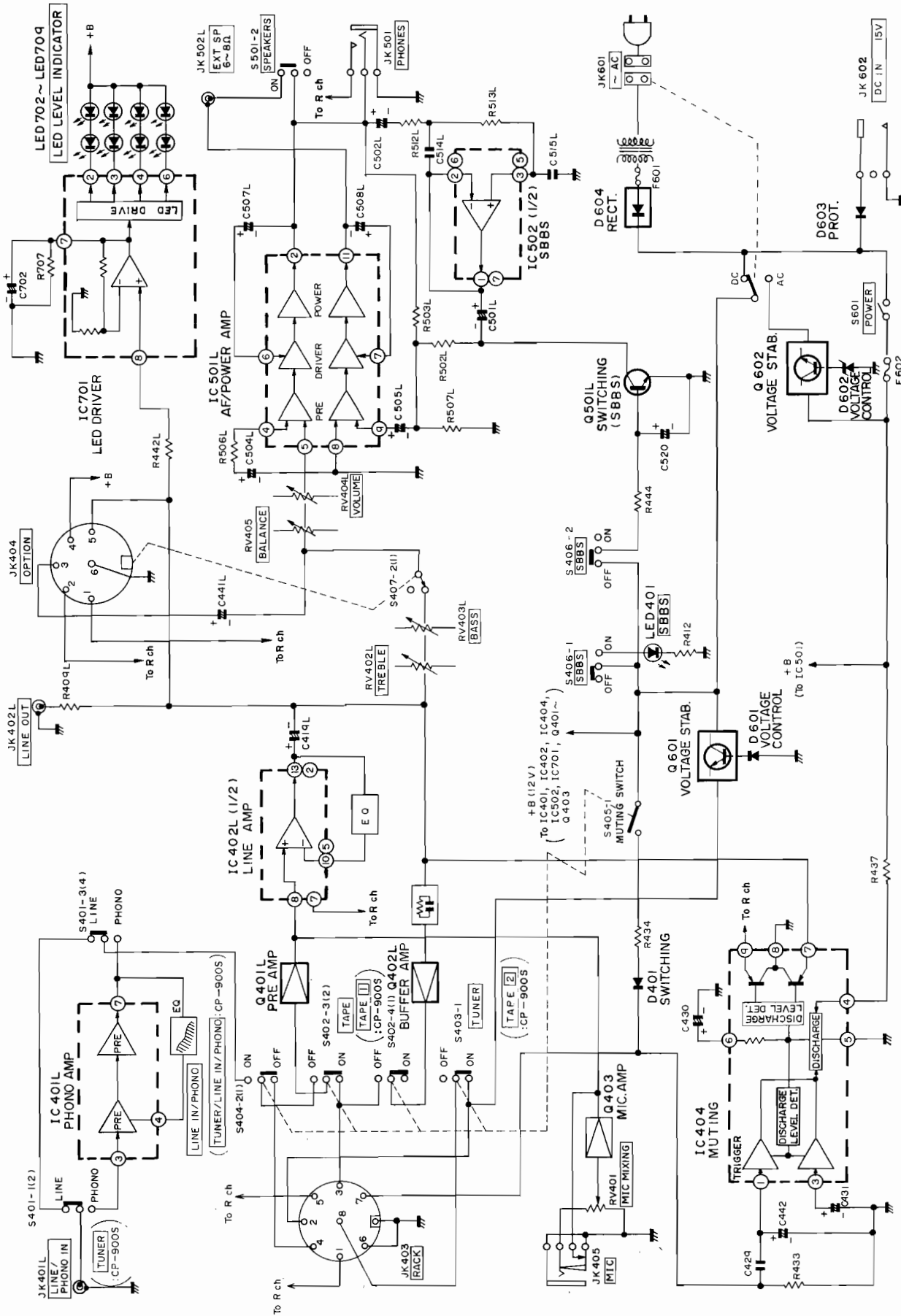

CONNECTORS

1. Stereo Amplifier (CP-90S/CP-900S)

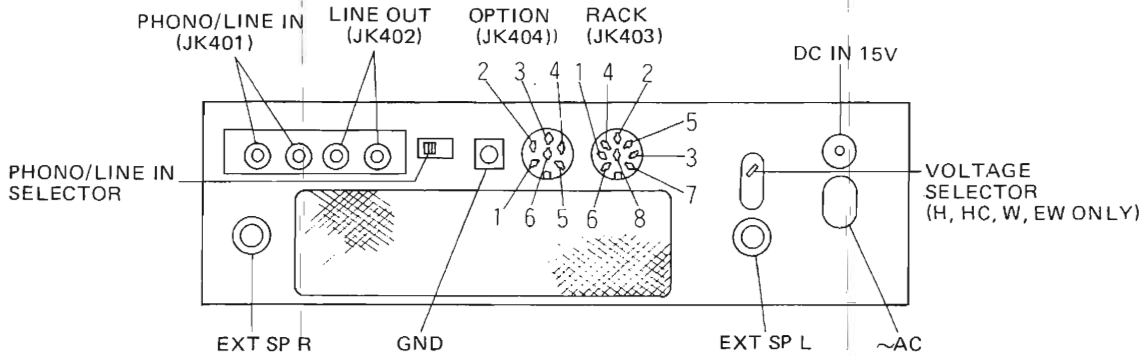

System CP-90S			System CP-900S		
Connector	Terminal	Input/Output	Connector	Terminal	Input/Output
PHONO/ LINE IN (JK401)		Phono or Line input (L, R)	PHONO/ LINE IN (JK401)		CP-90T signal input (L, R)
LINE OUT (JK402)		Line output (L, R)	LINE OUT (JK402)		Line output (L, R)
GND		Amplifier GND	GND		Amplifier GND
RACK (JK403) for CP-90REX	1	CP-90DEX R signal input/ output	RACK (JK403) for CP-90REX	1	CP-90DEX R signal input/ output
	2	+3V power output		2	+3V power output
	3	CP-90DEX L signal input/ output		3	CP-90DEX L signal input/ output
	4	CP-90T L signal input		4	CP-91DEX L signal input
	5	CP-90T R signal input		5	CP-91DEX R signal input
	6	GND		6	Blank
	7	Muting signal input		7	Muting signal input
	8	CP-90T +3V power output		8	+3V power output for CP-91DEX
OPTION (JK404) for CP-91EQ	1	CP-91EQ R signal input	OPTION (JK404) for CP-91EQ	1	CP-91EQ R signal input
	2	CP-91EQ R signal output		2	CP-91EQ R signal output
	3	CP-91EQ L signal input		3	CP-91EQ L signal input
	4	+12V power output		4	+12V power output
	5	CP-91EQ L signal output		5	CP-91EQ L signal output
	6	GND		6	GND
DC IN 15V		Car adaptor power input	DC IN 15V		Car adaptor power input
~AC		AC power input	~AC		AC power input
EXT SP L, R		Speaker output (L, R)	EXT SP L, R		Speaker output (L, R)

2. System Rack (CP-90REX)

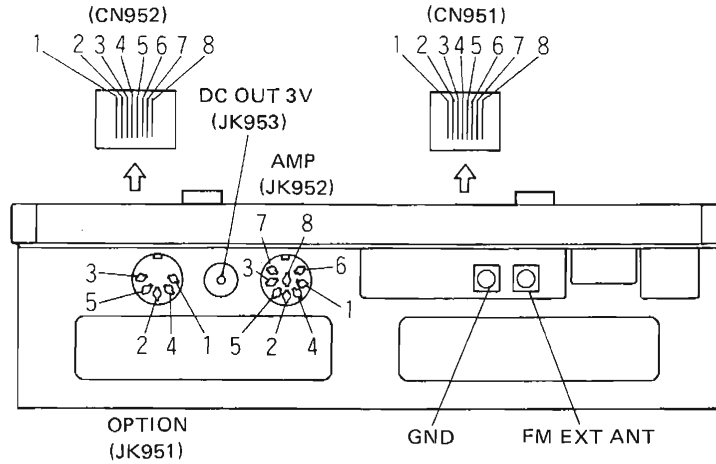

System CP-90S			System CP-900S		
Connector	Terminal	Input/Output	Connector	Terminal	Input/Output
CN951 Connector for CP-90T	1	R signal input	CN951 Connector for CP-91DEX	1	R signal input
	2	L signal input		2	L signal input
	3	GND		3	GND
	4	+3V power output		4	+3V power output
	5	Blank		5	Motor GND
	6	FM EXT. antenna output		6	Blank
	7	Blank		7	Blank
	8	Blank		8	Blank
CN952 Connector for CP-90DEX	1	R signal input/output	CN952 Connector for CP-90DEX	1	R signal input/output
	2	L signal input/output		2	L signal input/output
	3	GND		3	GND
	4	+3V power output		4	+3V power output
	5	REC muting input		5	REC muting input
	6	Blank		6	Blank
	7	Motor GND		7	Motor GND
	8	Motor +B		8	Motor +B
OPTION (JK951) for CP-91EQ	1	L decoder input/encoder output	OPTION (JK951) for CP-91EQ	1	L decoder input/encoder output
	2	GND		2	GND
	3	R encoder input/decoder output		3	R encoder input/decoder output
	4	R decoder input/encoder output		4	R decoder input/encoder output
	5	L encoder input/decoder output		5	L encoder input/decoder output
AMP (JK952) for CP-90S	1	CP-90DEX R signal input/output	AMP (JK952) for CP-900S	1	CP-90DEX R signal input/output
	2	+3V power input		2	+3V power input
	3	CP-90DEX L signal input/output		3	CP-90DEX L signal input/output
	4	CP-90T L signal output		4	CP-91DEX L signal output
	5	CP-90T R signal output		5	CP-91DEX R signal output
	6	GND		6	GND
	7	Muting signal input/output		7	Muting signal input/output
	8	CP-90T +3V power input		8	CP-91DEX +3V power input
GND		Antenna GND	GND		Antenna GND
FM EXT ANT		FM external antenna input	FM EXT ANT		FM external antenna input
DC OUT 3V(JK953)			DC OUT 3V(JK953)		CP-90T +3V power output

## DISASSEMBLY

## 1. Stereo Amplifier (CP-90S/CP-900S)

## 1. Back cover

After removing the (A) (eight) joint holder fixing screws, remove the (B) (six) screws.

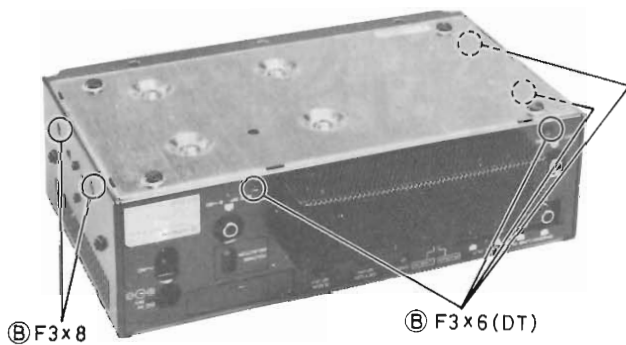

## 2. Front panel

- 1) Remove the five knobs (Mic mixing, Bass, Treble, Balance, Volume).
- 2) Remove the (C) (two) screws.

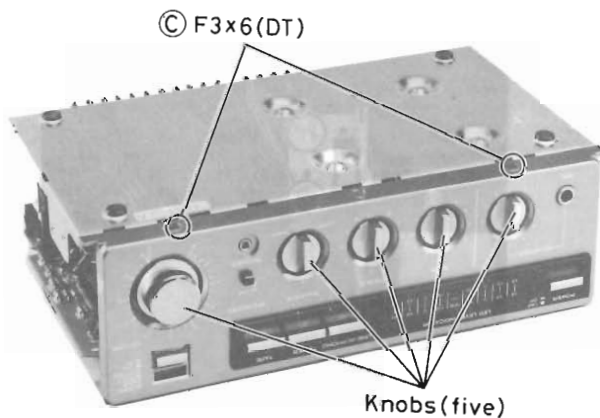

## 3. Switch/Jack PC board

After removing the (D) (five) screws, remove the (E) (two) connectors.

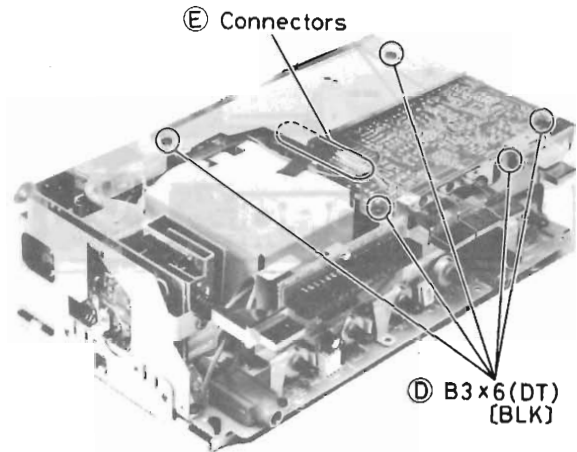

## 4. Power PC board

- 1) Remove the (F) (two) power PC board bracket fixing screws.
- 2) Lift up the power PC board bracket and remove the (G) (two) connectors.
- 3) Remove the (H) (two) screws.

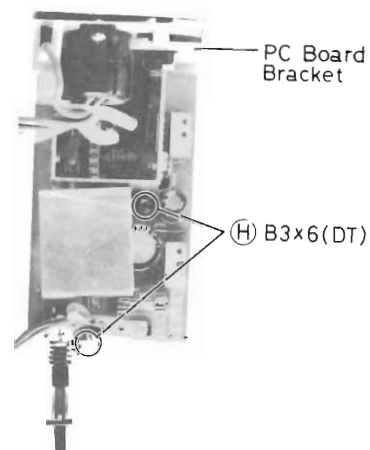
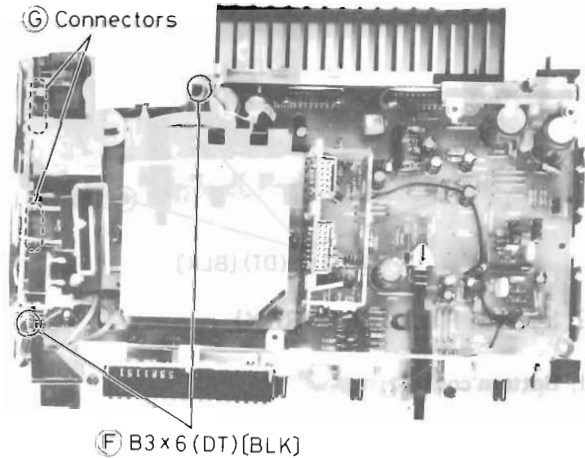

**5. Indicator PC board**

Remove the (I) (two) tabs and lift up the PC board.

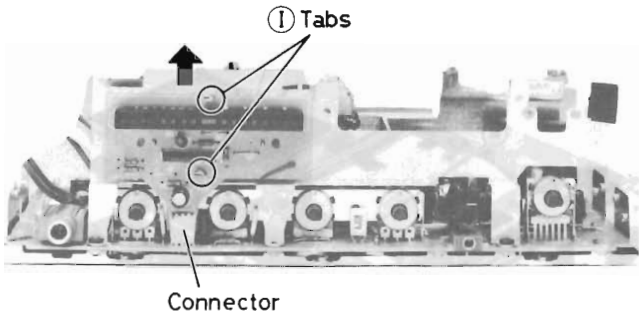

**6. Audio PC board**

Remove the (J) (three) screws.

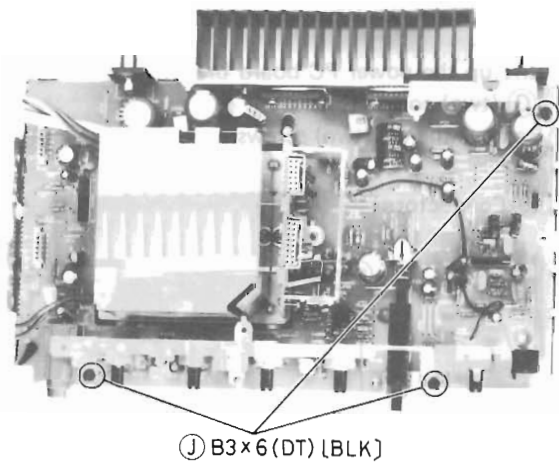

**2. Rack PC board**

- 1) Remove the (L) (six) PC board cover fixing screws.
- 2) Push the 8P connectors in the direction of the arrow and remove the PC board.

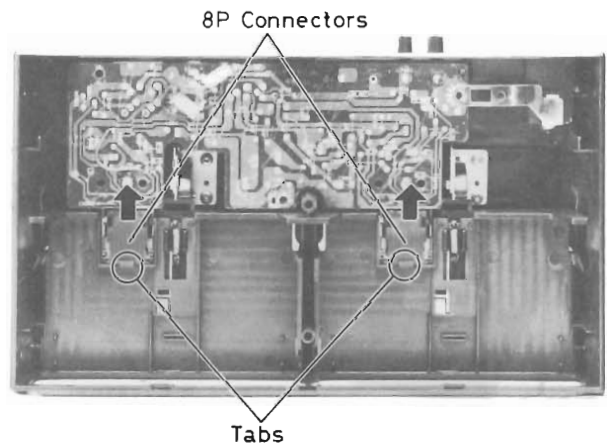
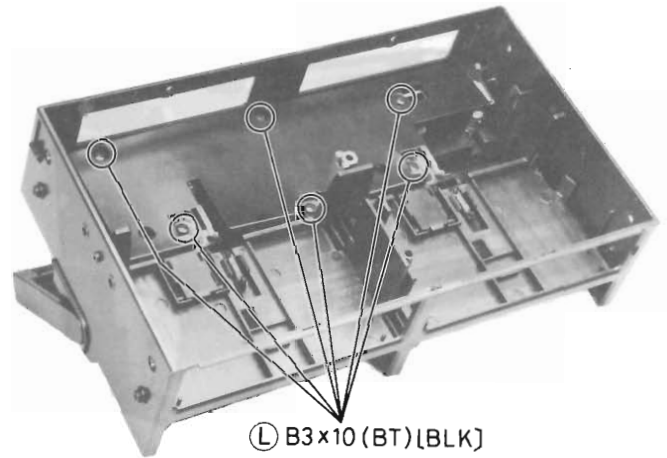

**2. System Rack (CP-90REX)**

**1. Bottom cover**

Remove the (K) (seven) screws.

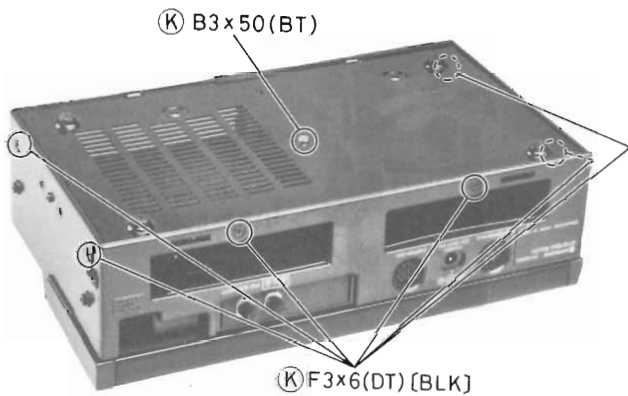

**3. Release button**

Remove the (M) (two) screws.

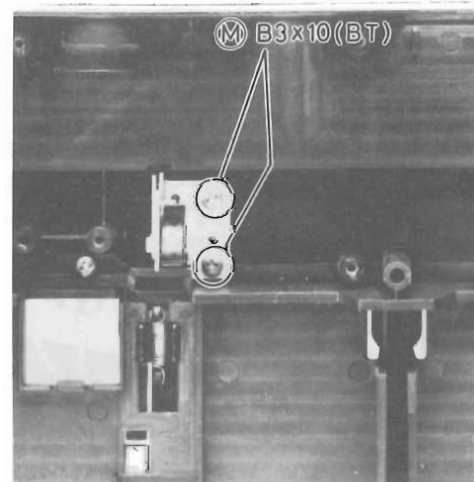

3. Speaker (CP-90SP)

1. Baffle plate assembly

Remove the (N) (four) screws.

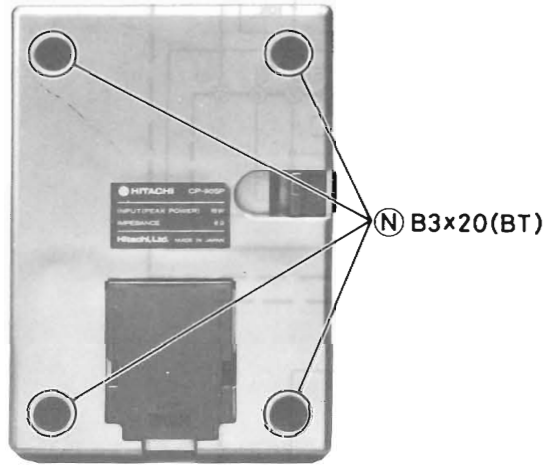

2. Woofer/Tweeter

Remove the (O) (six) screws.

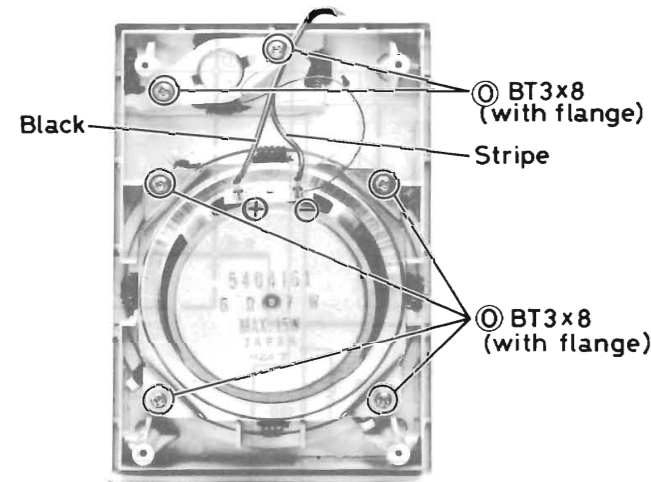

REPLACEMENT PARTS LIST

SYMBOL-NO	P-NO	DESCRIPTION	SYMBOL-NO	P-NO	DESCRIPTION
CAPACITORS			C961	0209010	CERAMIC DISC (RESISTOR SHAPE) 1000P F+-10%
C415LR	0208135	CERAMIC DISC (RESISTOR SHAPE) 33PF+-5%	RESISTORS		
C420LR	0209010	CERAMIC DISC (RESISTOR SHAPE) 1000P F+-10%	RC601-602	0186451	CR PACK [CP-90SH/HC, CP-900SAU/W]
C421LR	0209026	CERAMIC DISC (RESISTOR SHAPE) 0.01M F+-30%	RV401	5008931	VARIABLE RESISTOR 10KOHM(B)
C424LR	0209010	CERAMIC DISC (RESISTOR SHAPE) 1000P F+-10%	RV402LR	5008931	VARIABLE RESISTOR 10KOHM(B)
C434LR	0209023	CERAMIC DISC (RESISTOR SHAPE) 3300P F+-30%	RV403LR	5008931	VARIABLE RESISTOR 10KOHM(B)
C436LR	0209025	CERAMIC DISC (RESISTOR SHAPE) 6800P F+-30%	RV404LR	5001192	VARIABLE RESISTOR 10KOHM(A)
C442	0209026	CERAMIC DISC (RESISTOR SHAPE) 0.01M F+-30%	RV405	5008931	VARIABLE RESISTOR 10KOHM(B)
C447LR	0209010	CERAMIC DISC (RESISTOR SHAPE) 1000P F+-10%	SEMI-CONDUCTORS		
C503LR	0209010	CERAMIC DISC (RESISTOR SHAPE) 1000P F+-10%	D401	5330573	DIODE 1S2473
C605	0256648	ELECTROLYTIC 2200MF 25V	D601	5330716	ZENER DIODE HZ4C2
C701	0256163	ELECTROLYTIC 100MF 16V	D602	5330531	ZENER DIODE SILICON HZ-12A
C702	0256155	ELECTROLYTIC 10MF 16V	D603	5330501	DIODE SILICON UO-5B
			D604	5330831	DIODE S5VB10
			D951-952	5330573	DIODE 1S2473
			IC401LR	5350251	IC HA1406
			IC402LR	5357002	IC TA1024A

SYMBOL-NO	P-NO	DESCRIPTION	SYMBOL-NO	P-NO	DESCRIPTION
SEMI-CONDUCTORS					
IC404	5352791	IC TA7324P	△ F602	5720173	FUSE 0.5A [CP-90SE/EZ/E(BS)/EW]
IC501LR	5355681	IC AN7156N	△ F602	5720174	FUSE 0.63A [CP-900SE/AU/W]
IC502	5369181	IC H5218L	△ F602	5721401	FUSE 0.5A [CP-90SH/HC]
IC701	5352571	IC BA6124	△ F603	5720175	FUSE 0.8A [CP-90SEW, CP-900SW]
LED401	5381141	LED LND2026P3	JK401LR } JK402LR }	5676261	PIN JACK ASSEMBLY (PHONO/LINE IN, LINE OUT)
LED701-709	5381151	LED SLP5054-05	JK403	5677131	8P DIN SOCKET (RACK)
Q401LR	5321293	TRANSISTOR 2SC1740LN-R	JK404	5677401	6P DIN SOCKET (OPTION)
Q402LR	5321293	TRANSISTOR 2SC1740LN-R	JK405	5674451	JACK-6.4MM (MIC MIXING)
Q403	5321293	TRANSISTOR 2SC1740LN-R	JK501	5673402	JACK-3.5MM (HEADPHONE)
Q501LR	5322462	TRANSISTOR 2SD636R	JK502LR	5676331	PIN JACK (EXT. SP.)
Q601	5323461	TRANSISTOR 2SD1266PQ	△ JK601-602	5652122	AC-DC SOCKET [CP-90SH/HC/EW, CP-900SAU/W]
Q602	5323461	TRANSISTOR 2SD1266PQ	△ JK601-602	5653242	AC-DC SOCKET [CP-90SE/EZ/E(BS), CP-900SE]
Q901	5321252	2SA844D	JK951	5677192	5P DIN SOCKET (OPTION)
TRANSFORMERS					
△ PT601	5213373	POWER TRANSFORMER [CP-90SE/EZ, CP-900SE]	JK952	5677131	8P DIN SOCKET (AMP)
△ PT601	5213374	POWER TRANSFORMER [CP-90SE(BS), CP-900SAU]	JK953	5672091	DC JACK (DC OUT 3V)
△ PT601	5213375	POWER TRANSFORMER [CP-90SH/HC/EW, CP-900SW]	PL401	5663714	6P CONNECTOR PLUG
COILS					
L501-502	5150761	CHOKO COIL	PL402	5663715	8P CONNECTOR PLUG
L951-952	5150579	CHOKO COIL 510 MICRO H	PL601	5663714	6P CONNECTOR PLUG
L954-955	5150579	CHOKO COIL 510 MICRO H	PL602	5663714	6P CONNECTOR PLUG
L956-957	5123271	FM TRAP COIL 0.5MH	S0401	5653574	6P CONNECTOR SOCKET
L960	5150013	CHOKO COIL 0.25 MICRO H	S0402	5653575	8P CONNECTOR SOCKET
MISCELLANEOUS					
	5659101	BACK COVER [CP-90SH/HC/EW, CP-900SAU/W]	S0601	5653574	6P CONNECTOR SOCKET
	5659121	BACK COVER [CP-90SE/EZ/E(BS), CP-900SE]	S0602	5653574	6P CONNECTOR SOCKET
	5686193	FM EXT ANTENNA TERMINAL [CP-90SE/E(BS)/EW, CP-900SE/AU/W]	S401	5622022	SLIDE SWITCH (PHONO/LINE IN)
	5686201	TERMINAL PLATE (GND)	S402-405	5634553	PUSH SWITCH (FUNCTION, MUTE)
△ F601	5721066	FUSE 6.3A [CP-90SE/EZ/E(BS)/EW, CP-900SE/AU/W]	S406	5634419	PUSH SWITCH (SBBS)
△ F601	5721411	FUSE 5A [CP-90SH/HC]	S501	5634561	PUSH SWITCH (SPEAKER)
			S601	5634571	PUSH SWITCH (POWER)
			△ S602	5605054	VOLTAGE SELECTOR SWITCH [CP-90SH/HC/EW, CP-900SW]

**SCHEMATIC DIAGRAM (Stereo Amplifier, CP-90S/CP-900S)**

- |                                   |                                    |                                       |                               |                                   |  |                               |  |                           |                                 |                               |                                      |                                  |                                     |                                 |                               |                          |  |                        |
|-----------------------------------|------------------------------------|---------------------------------------|-------------------------------|-----------------------------------|--|-------------------------------|--|---------------------------|---------------------------------|-------------------------------|--------------------------------------|----------------------------------|-------------------------------------|---------------------------------|-------------------------------|--------------------------|--|------------------------|
| IC 401L,R<br>HA 1406<br>PHONO AMP | Q 401L,R<br>2SC1740LN-R<br>PRE AMP | Q 402L,R<br>2SC1740LN-R<br>BUFFER AMP | D 401<br>IS 2473<br>SWITCHING | IC 402L,R<br>TA 1024A<br>LINE AMP | Q 501L,R<br>2SD636-R<br>SWITCHING<br>(SBB S) | IC 701<br>BA6124<br>LED DRIVE | IC 501L,R<br>AN7156N<br>BTL AF/POWER AMP | IC 502<br>M5218L<br>SBB S | Q 403<br>2SC1740LN-R<br>MIC AMP | IC 404<br>TA 7324 P<br>MUTING | Q 601<br>2SD 1266PQ<br>VOLTAGE STAB. | D 601<br>HZ 4C2<br>VOLTAGE CONT. | Q 602<br>2SD1266PQ<br>VOLTAGE STAB. | D 602<br>HZ12A<br>VOLTAGE CONT. | LED 401<br>LN0202GP3<br>SBB S | D 604<br>S5VB10<br>RECT. | LED 701-LED 709<br>SLP5054-05<br>LED LEVEL INDICATOR | D 603<br>U058<br>PROT. |
|-----------------------------------|------------------------------------|---------------------------------------|-------------------------------|-----------------------------------|--|-------------------------------|--|---------------------------|---------------------------------|-------------------------------|--------------------------------------|----------------------------------|-------------------------------------|---------------------------------|-------------------------------|--------------------------|--|------------------------|

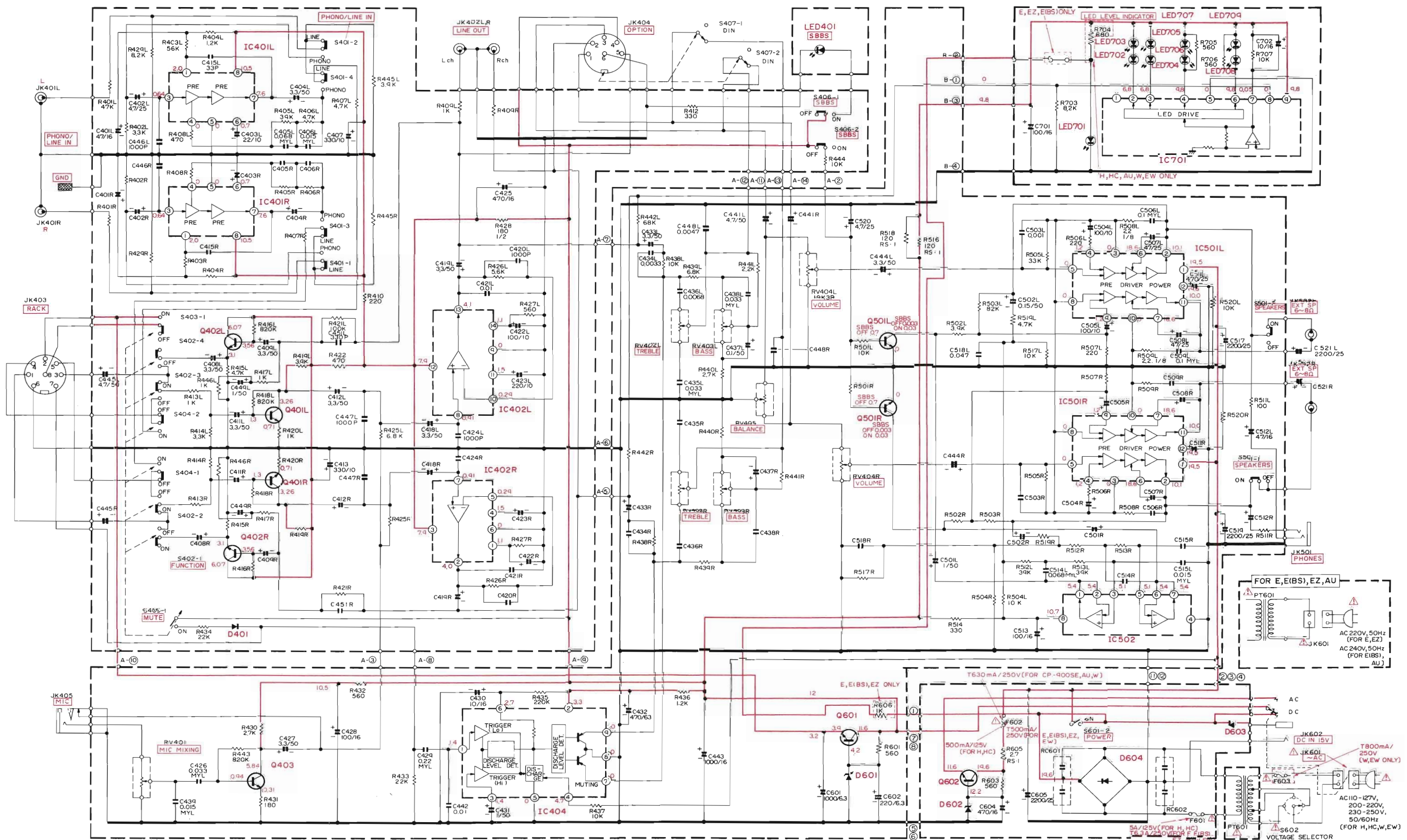



CIRCUIT BOARD DIAGRAM (Stereo Amplifier, CP-90S/CP-900S)

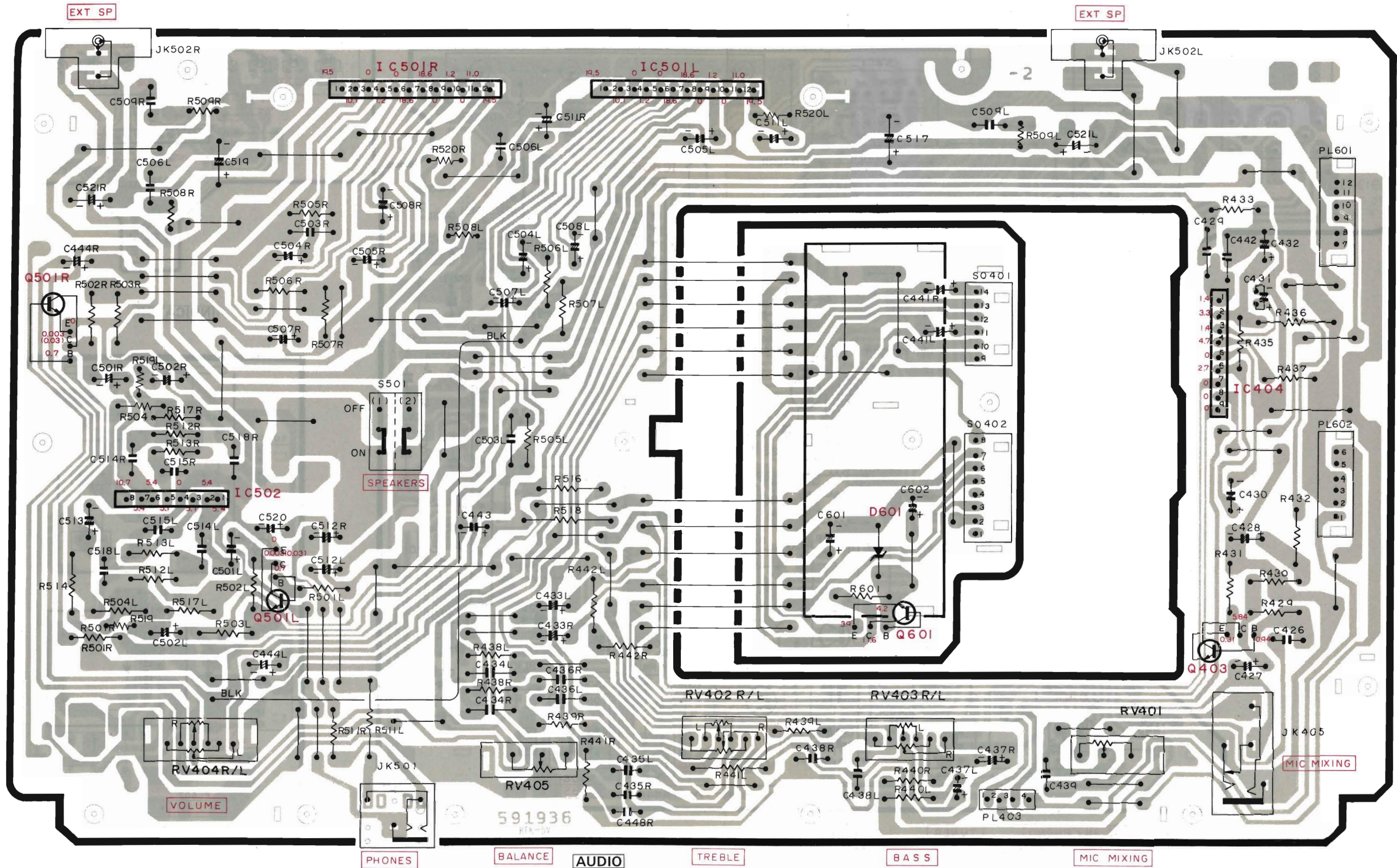

CIRCUIT BOARD DIAGRAM (Stereo Amplifier, CP-90S/CP-900S)

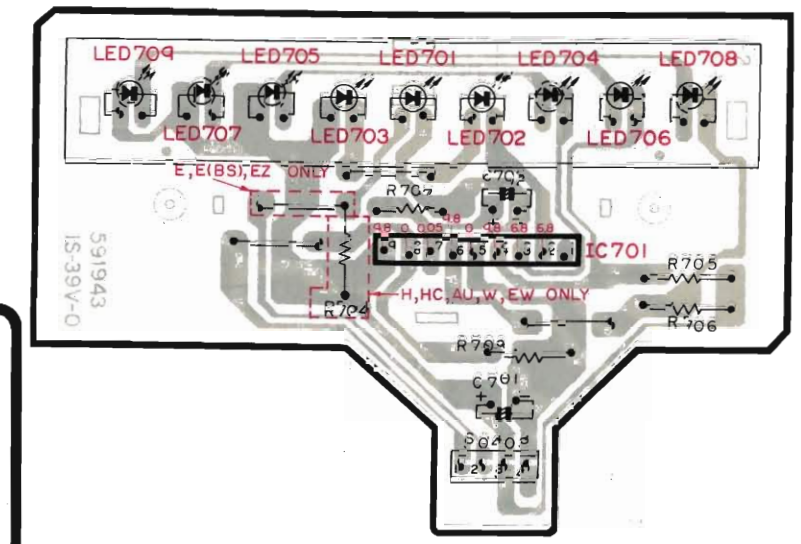
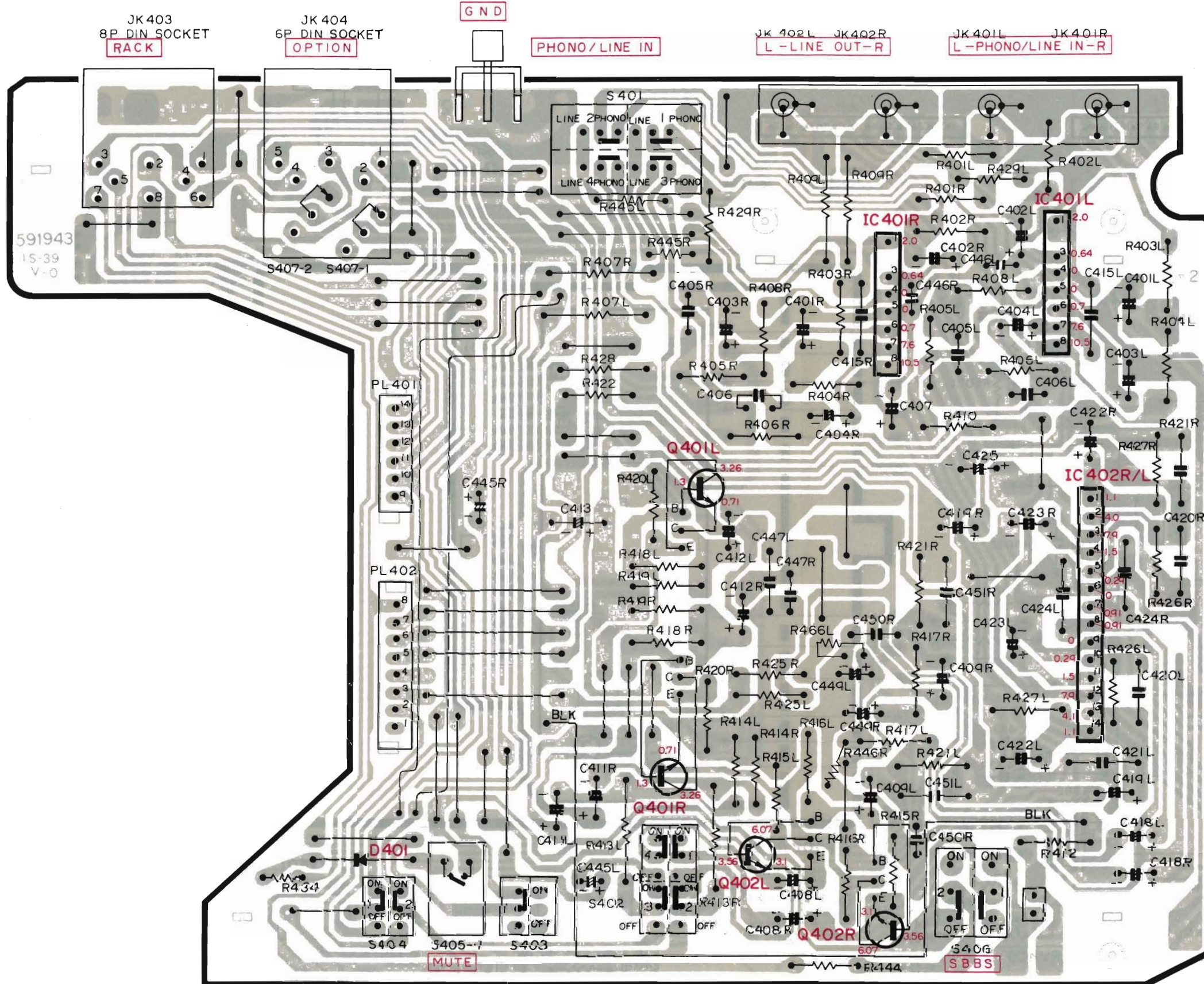

INDICATOR

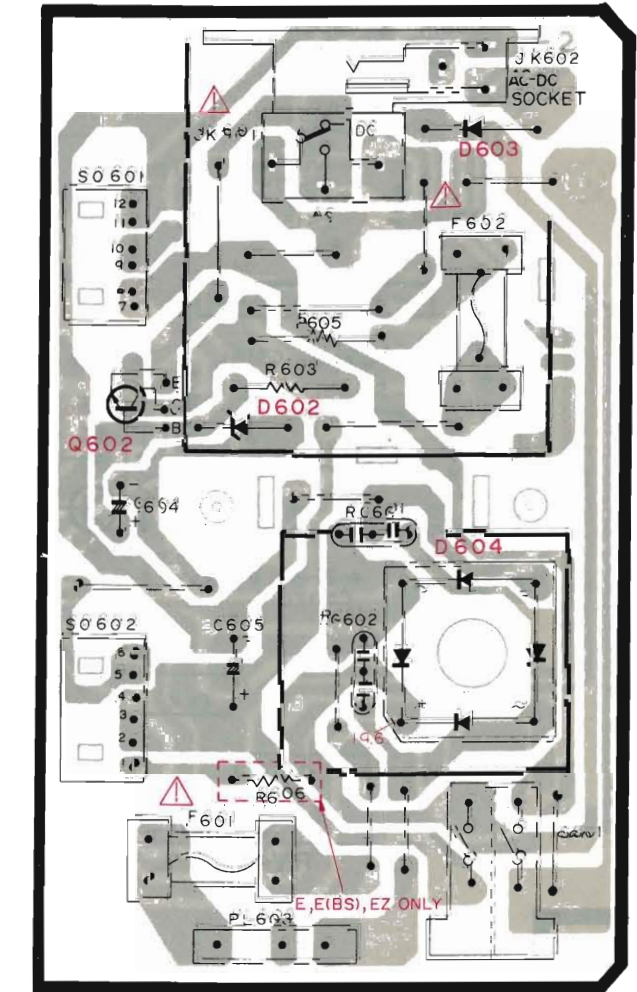

POWER

CP-90S: LINE IN / PHONO    TUNER    TAPE  
 CP-900S: ( TUNER / LINE IN / PHONO ) ( TAPE [2] ) ( TAPE [1] )  
 SWITCH/JACK

WIRING DIAGRAM (Stereo Amplifier, CP-90S/CP-900S)

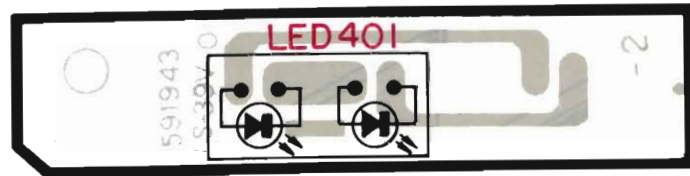

LED

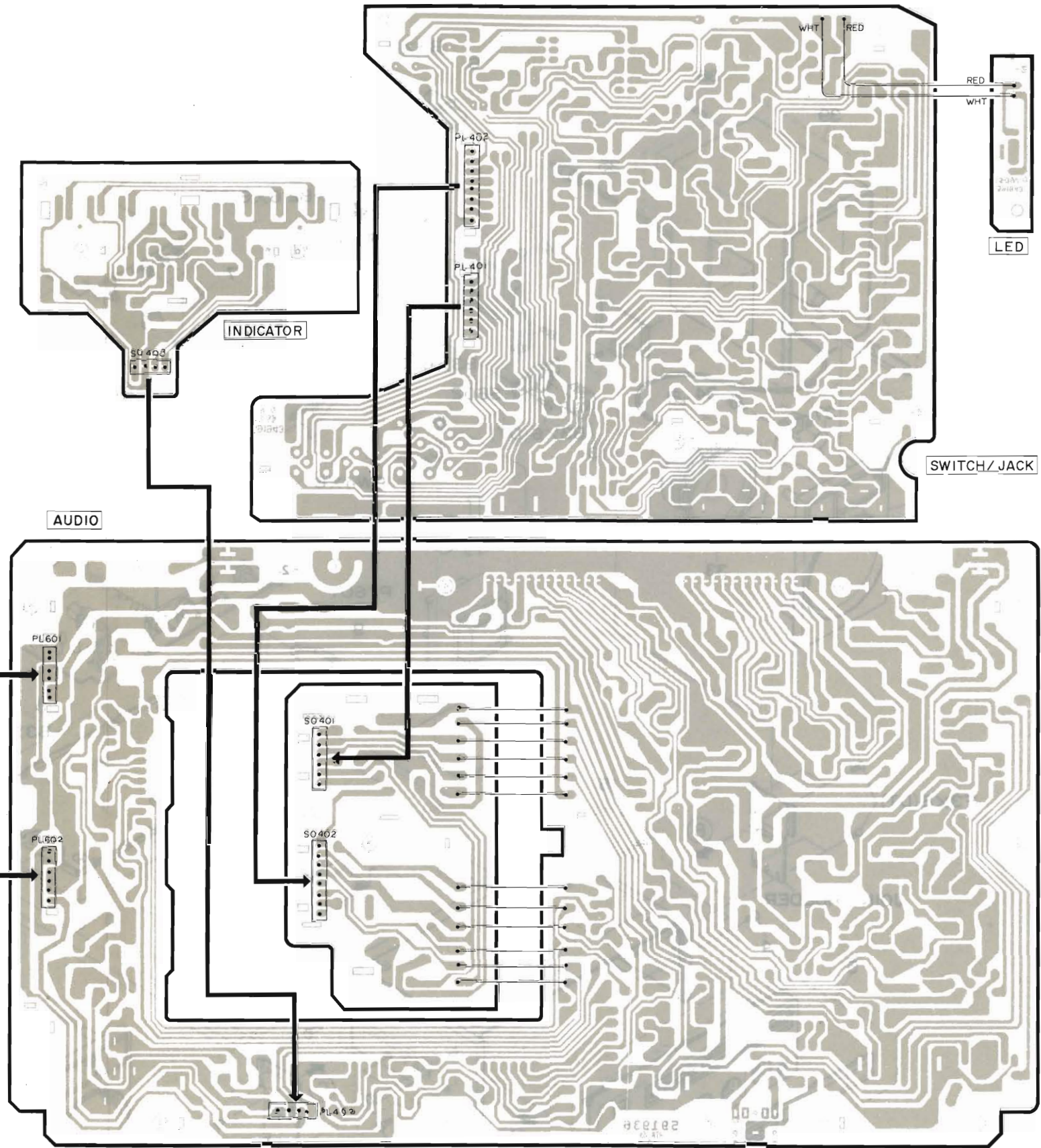
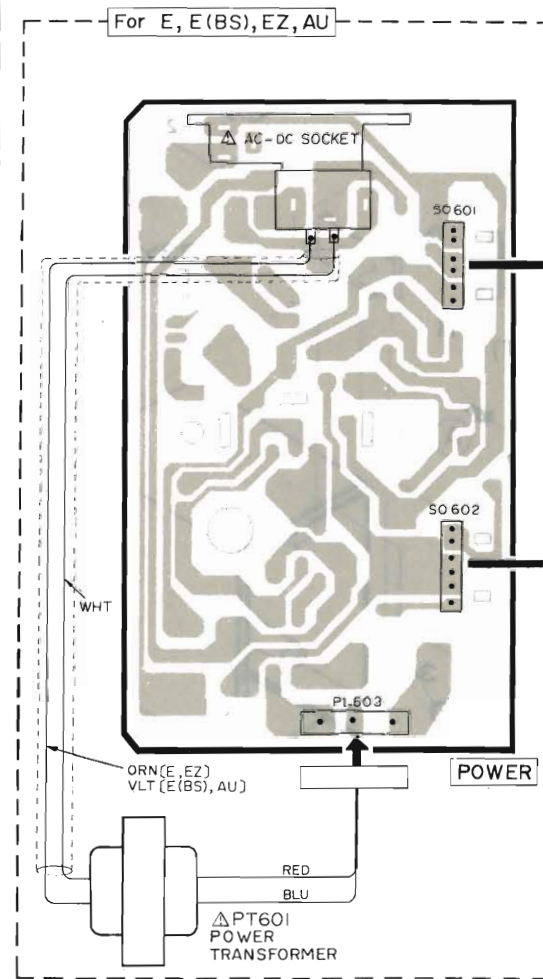
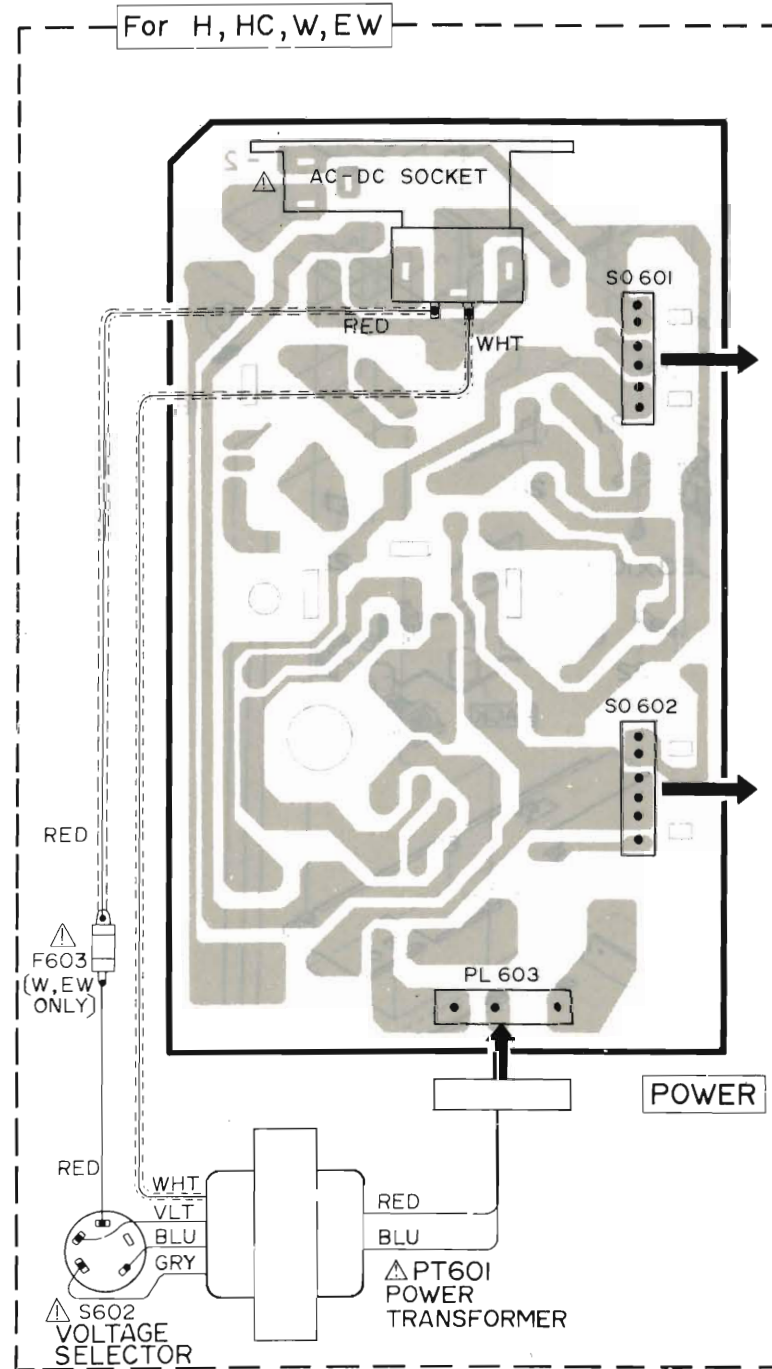





## REPLACEMENT PARTS LIST

SYMBOL-NO.	P-NO.	DESCRIPTION	SYMBOL-NO.	P-NO.	DESCRIPTION
FOR CASE ASSEMBLY			24	8678408	DT SCREW-3MMD x 8MM
1	6284051	KNOB (MIX MIC, BASS, TREBLE, BALANCE)	25	7351111	UP BUTTON ASSEMBLY
2	6284211	KNOB (VOLUME)	26	6774641	UP SLIDER
3	8602406	DT FLAT SCREW-3MMD x 6MM	27	6774651	SHAFT
4	8724408	FLAT SCREW-3MMD x 8MM (BLACK)	28	7351051	ANTENNA TERMINAL
5	6226213	FRONT PANEL ASSEMBLY [CP-90SH/HC/EW]	29	6541605	SPRING
5	6226214	FRONT PANEL ASSEMBLY [CP-90SE/EZ/E(BS)]	30	8699410	BT BIND SCREW-3MMDx10MM(BLACK)
5	6226215	FRONT PANEL ASSEMBLY [CP-900SAU/W]	31	6036952	R-SPEAKER BOX ASSEMBLY [CP-90SH/HC/EZ/E(BS)/EW, CP-900SAU/W]
5	6226216	FRONT PANEL ASSEMBLY [CP-900SE]	31	6036954	R-SPEAKER BOX ASSEMBLY [CP-90SE, CP-900SE]
6	6293361	PUSH BUTTON (POWER)	32	6036863	R-BAFFLE PLATE ASSEMBLY
7	6293371	PUSH BUTTON (FUNCTION)	33	5404161	SPEAKER-9CM
8	6293381	PUSH BUTTON (SBBS)	34	7781133	BT SCREW-3MMD x 8MM
9	6293391	PUSH BUTTON (SPEAKER)	35	5746981	SPEAKER CORD [CP-90SE/EZ/E(BS)/EW, CP-900SE/AU/W]
10	6774431	MOULD LEG	35	5746982	SPEAKER CORD [CP-90SH/HC]
11	7350601	CONNECTOR BRACKET	36	7781146	BT SCREW-3MMD x 20MM
△	6746881	FUSE COVER [CP-90SEW, CP-900SW]	37	5419071	SPEAKER-2CM
△	6769241	SWITCH COVER [CP-90SH/HC/EW, CP-900SW]	38	6774412	SPEAKER HOLDER
14	8678406	DT SCREW-3MMD x 6MM (BLACK)	39	6036972	L-SPEAKER BOX ASSEMBLY [CP-90SH/HC/EZ/E(BS)/EW, CP-900SAU/W]
15	6036792	AMP COVER ASSEMBLY [CP-900SW]	39	6036974	L-SPEAKER BOX ASSEMBLY [CP-90SE, CP-900SE]
15	6036793	AMP COVER ASSEMBLY [CP-900SAU]	40	6036864	L-BAFFLE PLATE ASSEMBLY
15	6036794	AMP COVER ASSEMBLY [CP-90SE]	FOR ACCESSORIES		
15	6036795	AMP COVER ASSEMBLY [CP-90SEZ]	△	5660212	SIEMENS PLUG [CP-90SH/HC/EW, CP-900SW]
15	6036796	AMP COVER ASSEMBLY [CP-90SE(BS)]		5746952	8P DIN CORD [CP-90SH/HC]
15	6036797	AMP COVER ASSEMBLY [CP-90SH]		5746951	8P DIN CORD [CP-90SE/EZ/E(BS)/EW, CP-900SE/AU/W]
15	6036798	AMP COVER ASSEMBLY [CP-90SHC]		5732102	HEADPHONE (CP-90P)
15	6038282	AMP COVER ASSEMBLY [CP-900SE]	△	5747262	POWER CORD [CP-90SH/HC]
15	6038283	AMP COVER ASSEMBLY [CP-90SEW]	△	5747321	POWER CORD [CP-90SE/EZ, CP-900SE]
16	7351123	RACK PLATE ASSEMBLY	△	5746341	POWER CORD [CP-90SE(BS)]
17	6774602	RACK LID	△	5747472	POWER CORD [CP-90SEW, CP-900SW]
18	8602406	DT FLAT SCREW-3MMD x 6MM	△	5747172	POWER CORD [CP-900SAU]
19	—————	—————		7351983	JOINT HOLDER
20	6774762	RACK CASE ASSEMBLY [CP-900SAU/W]		8603408	DT FLAT SCREW-3MMD x 8MM
20	6774763	RACK CASE ASSEMBLY [CP-90SH/HC/EZ]		6037121	CARRYING CASE ASSEMBLY
20	6774764	RACK CASE ASSEMBLY [CP-90SE/E(BS)/EW, CP-900SE]		5746911	DC CORD [CP-900SE/AU/W]
21	6974481	HANDLE ASSEMBLY		5746921	RELAY CORD [CP-900SE/AU/W]
22	6531142	SPRING		6774431	MOULD LEG
23	5752711	ROD ANTENNA		7782951	SPECIAL SCREW

# STEREO CASSETTE RECORDER CP-90DEX

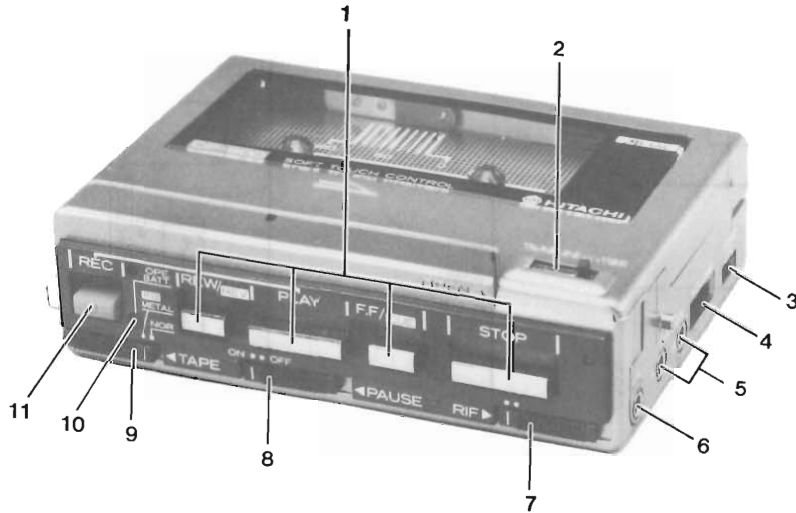

## KEY TO ILLUSTRATIONS

1. OPERATION BUTTONS
2. TAPE COUNTER
3. TONE SWITCH
4. VOLUME CONTROL
5. HEADPHONE SOCKETS
6. MICROPHONE SOCKET
7. RIF SWITCH
8. PAUSE SWITCH
9. TAPE SELECT SWITCH
10. OPERATION/BATTERY INDICATOR
11. RECORD BUTTON

## SPECIFICATIONS

**Tape:** Cassette tape (C-30, 60, 90)  
**Track System:** 4 track 2 channel  
**Tape Speed:** 4.75 cm/s  
**Recording System:** AC Bias, 57 kHz  
**Erasing System:** AC erase  
**Frequency Response:** Metal: 50 to 14,000 Hz  
 Normal: 50 to 12,000 Hz  
**S/N (Signal to Noise Ratio):** 50 dB  
**Distortion:** 2%  
**Motor:** DC micromotor  
**Cross Talk:** 50 dB (Between tracks)  
 30 dB (Between channels)  
**Erase Ratio:** 50 dB

**Input Sensitivity and Impedance:** Microphone: 0.3 mV, 3.3k ohms  
 Headphone: 8 ohms to 300 ohms  
**Output Impedance:** 0.2% (WRMS)  
**Wow and Flutter:** 0.2% (WRMS)  
**Fast Forward or Rewinding Time:** 120 sec. (Using C-60)  
**Semiconductors:** ICs: 4  
 Transistors: 9  
 Diode: 2  
 LED: 1  
**Power Output:** 30 mW + 30 mW (T.H.D. 10%)  
**Power Supply:** DC 3V ("AA" cell x 2 or IEC R6 x 2)  
**Power Consumption:** 160 mA (with no signal)  
**Dimensions:** 120(W) x 33.5(H) x 80(D) mm  
**Weight:** 320 g (with batteries)

## CONNECTORS

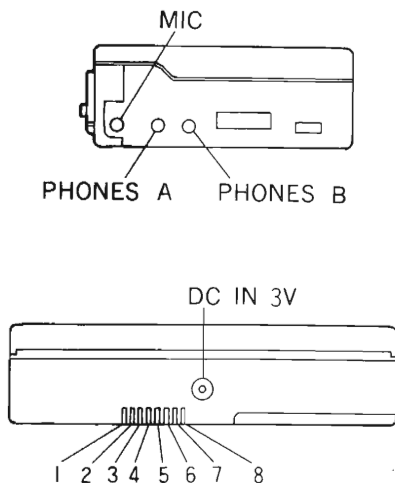

System CP-90S/CP-900S		
Connector	Terminal	Input/Output
8P pin Connector	1	R signal input/output
	2	L signal input/output
	3	GND
	4	+3V power input
	5	REC +B
	6	
	7	Motor GND
	8	Motor +B
Independently		
MIC		MIC input
PHONES	A	Headphone output
	B	Headphone output
DC IN 3V		+3V power input

BLOCK DIAGRAM

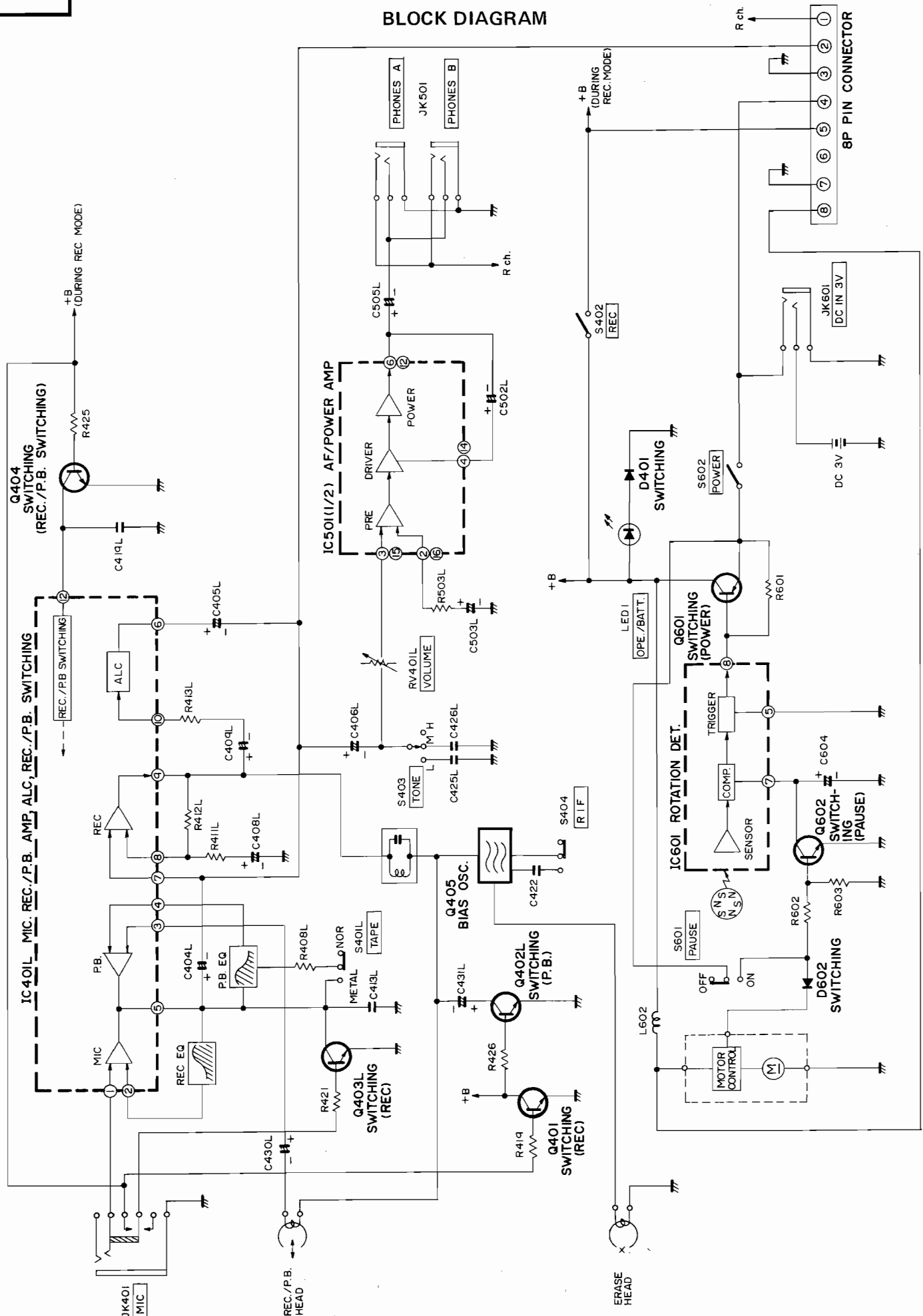



DISASSEMBLY

1. Cassette lid

Remove (A) (three) screws.

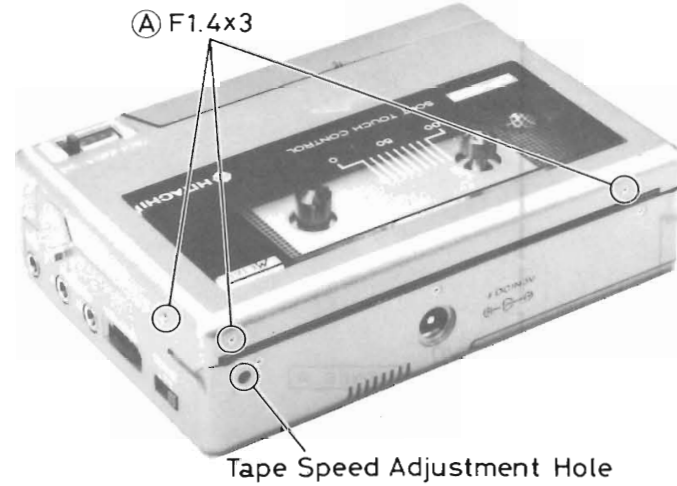

2. Escutcheon

Remove (B) (five) screws.

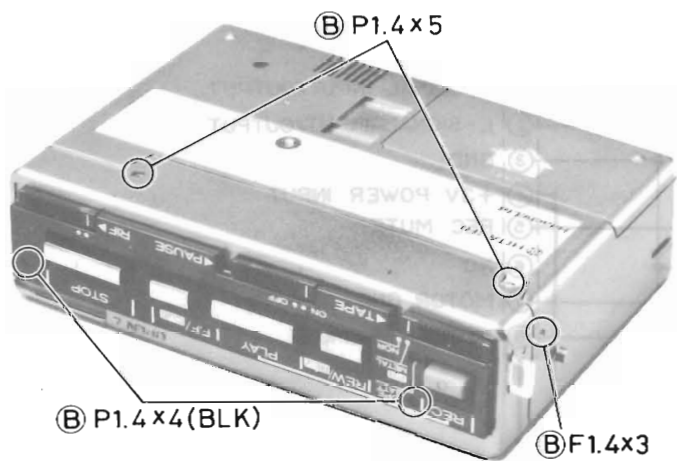

3. Rear case

1) Remove (C) (four) screws.  
2) Lift the record button side of the chassis a little and take out the chassis carefully.

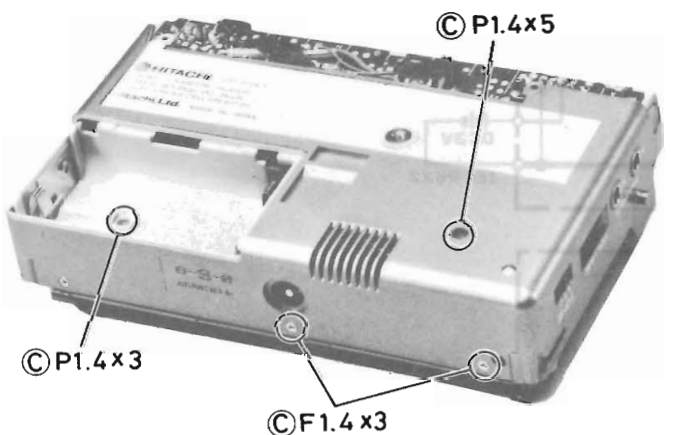

4. Main PC board

Remove (D) (three) screws.

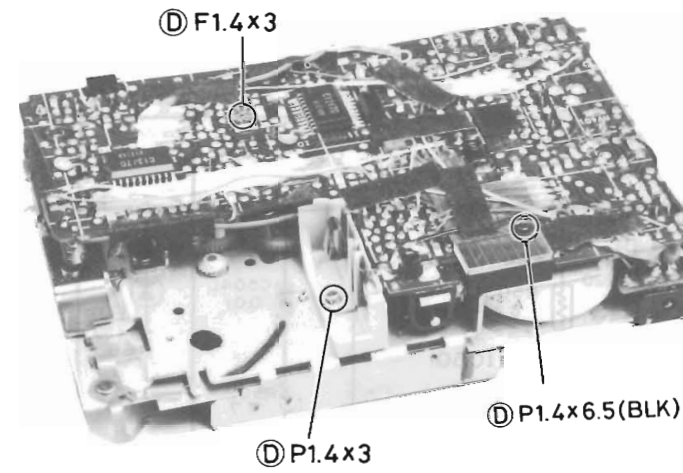

5. Decoration metal

Remove (E) (two) screws.

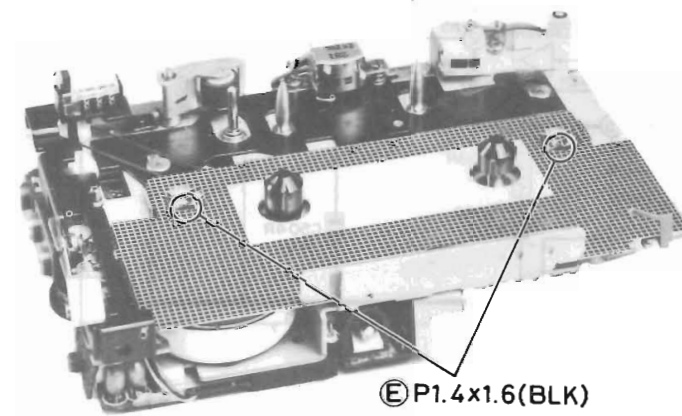

6. Eject/counter holder

Remove (F) (two) screws.

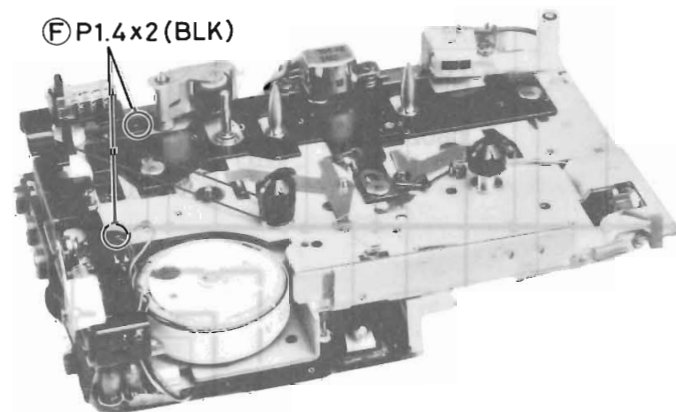

ADJUSTMENT

Perform the following adjustments in the sequence stated after cleaning the head, pressure roller, and capstan with a head cleaning stick moisted in alcohol.

Step	Adjustment Item	Measuring Instrument and connection			Check Tape	Mode	Adjusted Position	Adjusted Value	Remarks
		Measuring Instrument	Input Terminal	Output Terminal					
1	Tape speed	• Frequency counter	—	Headphone socket	Tape speed adjustment tape (3,000 Hz)	Playback	Semivariable resistor in the motor PC board	3,005Hz ±10 Hz	Note 1
2	Head azimuth	• VTVM	—	Headphone socket	Head azimuth adjustment tape (10 kHz)	Playback	Azimuth adjusting screw	Output Max.	Note 2
3	Record bias	• VTVM	—	Both ends of R430R (10 Ω)	—	Record	RT401	3.7 mV	Note 3

Note:

1. Adjust within 30 sec. after heat-running for more than 20 minutes.
2. When the maximum values of both channels are different, adjust to the maximum value of the L channel. In this case, the difference between the maximum values of both channels should be within 2 dB.
3. 1) Set the RIF switch to the "B" position in the recording mode.  
2) Connect the VTVM to both ends of R430R (10Ω) and adjust RT401 so that the bias current is 3.7 mV.

INSPECTION OF MECHANISM

Item	Checking item	Reference value	Remarks	
1	Pressure of pressure roller	200 g ± 40 g	Note 1	
2	Take-up torque	30 ~ 65 g.cm	Measure in cassette torque meter	
3	Fast forward torque	55 g. cm or more		
4	Rewind torque	55 g. cm or more		
5	Back tension torque	Take-up	2 g. cm or less	Measure without tape counter
		Supply	4.5 g. cm or less	
6	Button operation force	Play button	0.3 kg or less	Measure without leaf switches (REC, Power)
		Fast forward button	0.8 kg or less	
		Rewind button	0.5 kg or less	
		Stop button	0.5 kg or less	
		Record button	0.3 kg or less	
7	Flywheel thrust gap	0.1 ~ 0.2 mm		

Note:

1. Set this unit in the playback mode and press the pressure roller in the direction of the arrow using a fan type tension gauge, and measure the pressure when the pressure roller is released from the capstan.

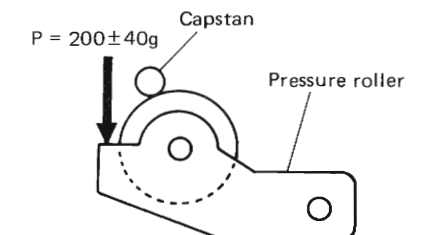

SCHMATIC DIAGRAM

IC401L,R μPC1217G MIC, REC./P.B. AMP, ALC, REC./P.B. SWITCHING	Q401 2SC1623(L5-6) SWITCHING (REC)	Q402L,R 2SC2462D SWITCHING (PLAY)	Q403L,R 2SC1623(L5-6) SWITCHING (REC.)	Q404 2SC1623(L5-6) SWITCHING (REC./PLAY)	Q405 2SC2603-E BIAS OSC	IC501 BA5204 AF/POWER AMP	D602 ISS133HV SWITCHING	Q602 2SC1623(L5-6) SWITCHING (PAUSE)	IC601 PST517 ROTATION DET.	D401 MA152WA SWITCHING	LED1 SLC22UR OPE, BATT.	Q601 2SB1001 SWITCHING (POWER)
--	---	--	---	---	-------------------------------	------------------------------------	-------------------------------	---	-------------------------------------	------------------------------	-------------------------------	---

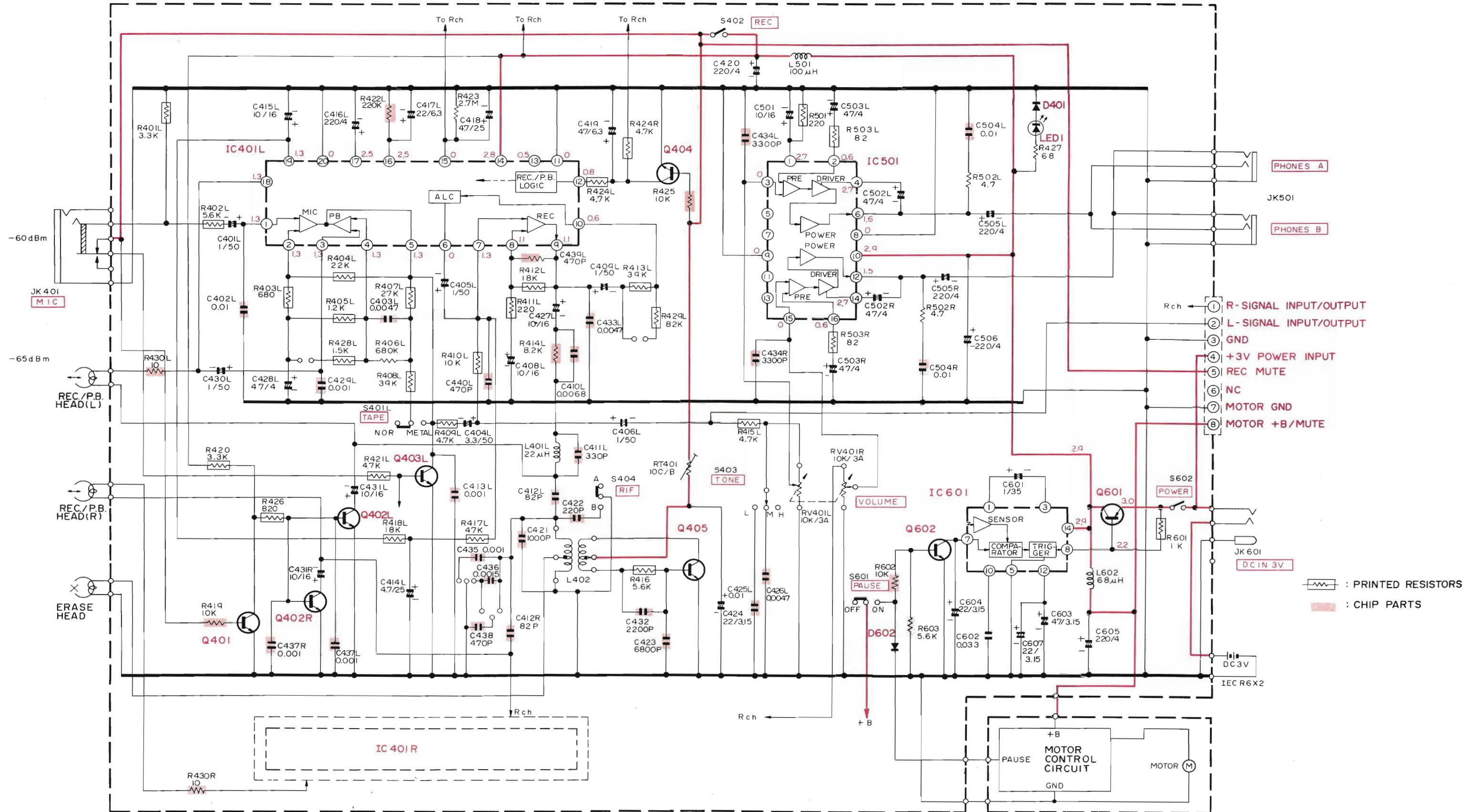

CIRCUIT BOARD DIAGRAM

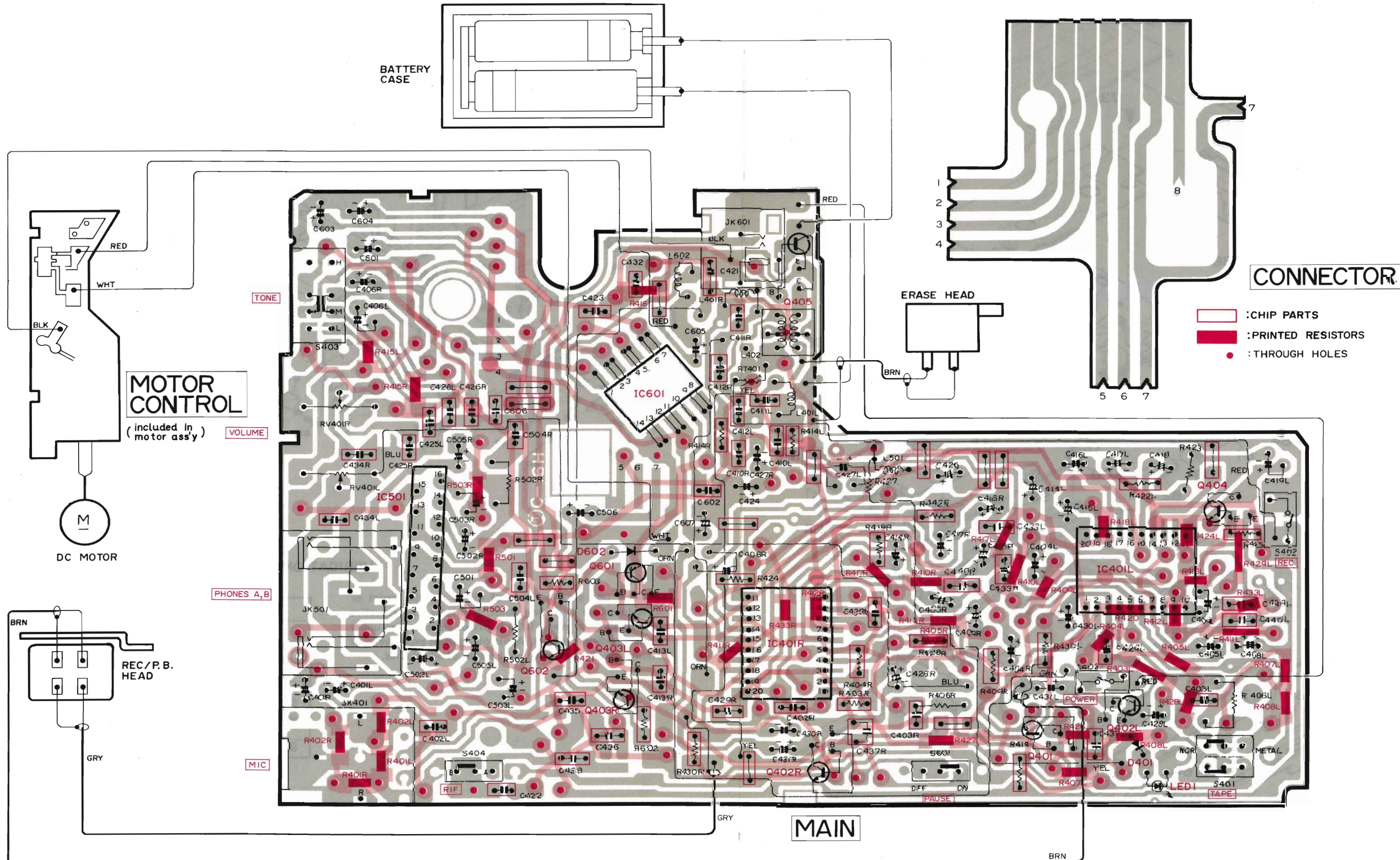

TONE

MOTOR CONTROL  
(included in motor ass'y)

VOLUME

PHONES A,B

MIC

REC/P.B. HEAD

MAIN

CONNECTOR

- :CHIP PARTS
- :PRINTED RESISTORS
- :THROUGH HOLES

EXPLODED VIEW (Cabinet)

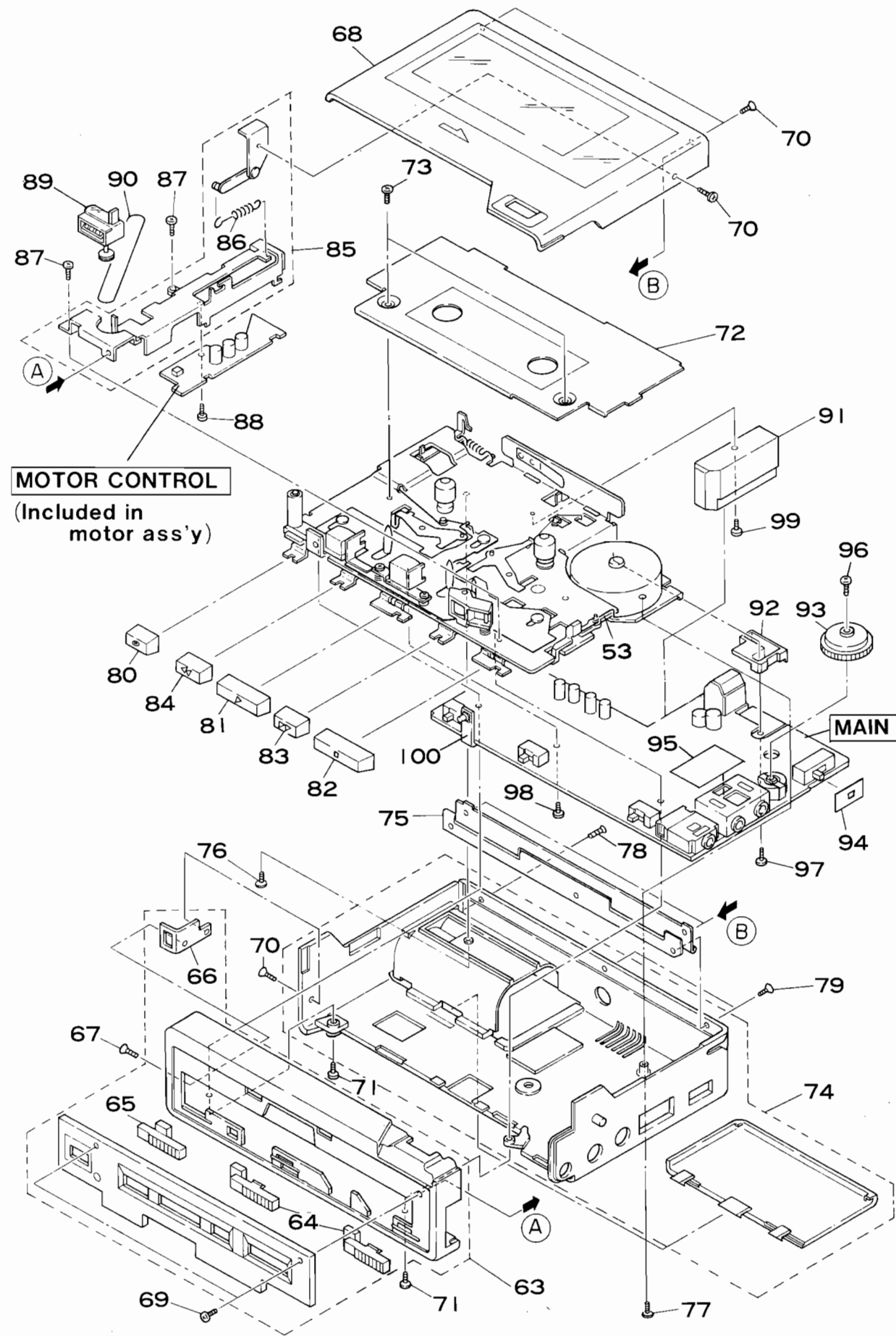

EXPLODED VIEW (Mechanism - SR - 1A)

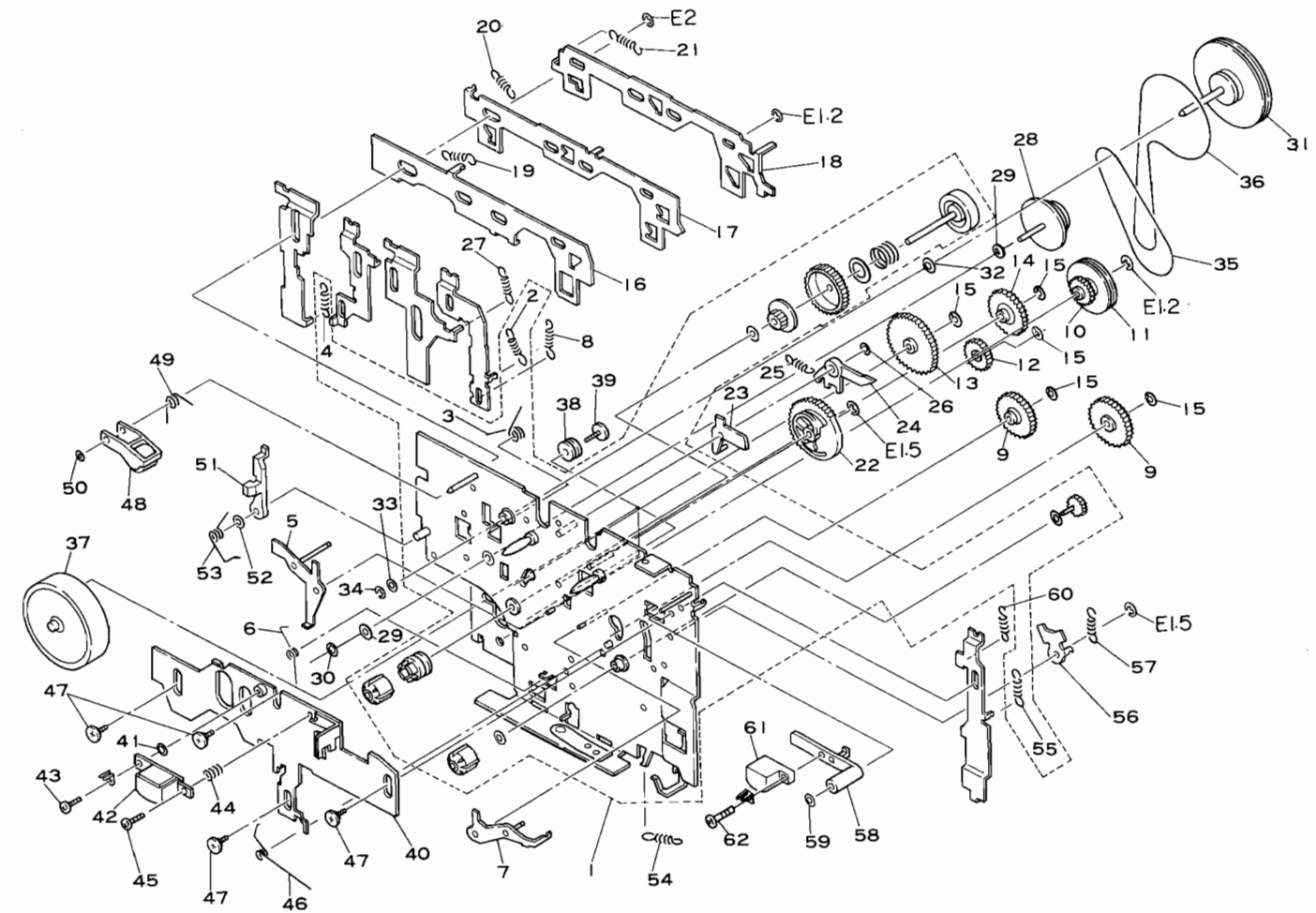

LUBRICATION

Lubricate one or two drops of oil to rotating point or lubricate grease to sliding point. Lubricate the respective parts listed once every 1000 hours or once a year under normal conditions of use. Avoid oiling them excessively, or rotation may become irregular because of oil splashes.

Lubrication point		Oil or Grease
Rotary section	Metal and metal	Pan motor oil (10W-40)
	Mold and metal	Sonic slider oil (#1600)
Sliding section	Metal and metal	Hitasol (MO-138)
	Mold and mold Mold and metal	Floil (GB-TS-1)
Spring resonance prevention		Floil (GB-TS-1)

Note: Components marked without numbers in this drawing are not specified as replacement parts.

## REPLACEMENT PARTS LIST

SYMBOL-NO	P-NO	DESCRIPTION	SYMBOL-NO	P-NO	DESCRIPTION
		MECHANISM (SR - 1A)	46	6548516	HEAD PLATE SPRING
1	7044231	SUB CHASSIS ASSEMBLY	47	7782822	SPECIAL SCREW
2	6543124	SPRING	48	6774491	PRESSURE ROLLER ARM ASSEMBLY
3	6548487	SPRING	49	6548533	SPRING
4	6543072	SPRING	50	7787563	POLY SLIDER WASHER
5	7350761	F.F ARM ASSEMBLY	51	6774581	REVIEW/CUE ARM
6	6548521	SPRING	52	7787563	POLY SLIDER WASHER
7	7350781	REWIND ARM ASSEMBLY	53	6548605	SPRING
8	6543091	SPRING	54	6542512	GEAR SPRING
9	6432491	REWIND IDLER GEAR	55	6543071	SPRING
10	6432462	GEAR	56	7350931	RECORD PLATE
11	6423032	MIDDLE PULLEY	57	6543102	SPRING
12	6432442	PLAY IDLER GEAR	58	6775081	ERASE HEAD ARM
13	6432451	F.F IDLER GEAR	59	7787563	POLY SLIDER WASHER
14	6432621	POWER ASSIST IDLER GEAR	60	6543062	SPRING
15	7787571	WASHER	61	5445521	ERASE HEAD
16	7350712	REVIEW/CUE PLATE	62	8691106	BT SCREW-2MMD x 6MM
17	7350722	LOCK PLATE			MISCELLANEOUS
18	7354021	SWITCH PLATE	63	6244851	ESCUTCHEON ASSEMBLY
19	6543131	SPRING	64	6293441	SLIDE KNOB(PAUSE, RIF)
20	6543111	SPRING	65	6293401	SLIDE KNOB(TAPE)
21	6543082	SPRING	66	7351541	STRAP HOLDER
22	6432524	POWER ASSIST CAM GEAR	67	8722005	FLAT SCREW-1.4MMDX3MM
23	6774461	PLAY LOCK ARM	68	6094323	CASSETTE LID ASSEMBLY
24	6774471	TRIGGER ARM	69	8714005	PAN HEAD SCREW-1.4MMDX4MM
25	6542514	SPRING	70	8722005	FLAT SCREW-1.4MMDX3MM
26	7788591	WASHER	71	8712027	PAN HEAD SCREW-1.4MMDX5MM
27	6543151	SPRING	72	6636732	DECORATION METAL
28	6423053	ANTI PULLEY ASSEMBLY	73	8714022	PAN HEAD SCREW-1.4MMDX1.6MM
29	7778854	POLY SLIDER WASHER	74	6037203	REAR CASE ASSEMBLY
30	7786213	WASHER	75	6337512	HINGE ASSEMBLY
31	6374292	FLYWHEEL ASSEMBLY	76	8712024	PAN HEAD SCREW-1.4MMDX3MM
32	7772625	SPRING	77	8712027	PAN HEAD SCREW-1.4MMDX5MM
33	7786119	POLY SLIDER WASHER	78	8722004	FLAT SCREW-1.4MMDX2MM
34	7774841	E RING-1.6MMD	79	8722005	FLAT SCREW-1.4MMDX3MM
35	6355791	BELT	80	6058011	BUTTON (RECORD)
36	6355521	BELT-1.0MMD	81	6058033	BUTTON(PLAY)
37	5577661	DC MOTOR	82	6058034	BUTTON(STOP)
38	6590271	RUBBER PLATE	83	6058023	BUTTON (F.F)
39	7782831	SCREW FOR MOTOR MOUNTING	84	6058024	BUTTON(REWIND)
40	7350744	HEAD PLATE ASSEMBLY	85	7351694	EJECT/COUNTER HOLDER ASSEMBLY
41	7779923	WASHER	86	6543043	SPRING
42	5449281	RECORD PLAYBACK HEAD	87	8714023	PAN HEAD SCREW-1.4MMDX2MM
43	8741103	SCREW (2MMD x 3MM)	88	8712024	PAN HEAD SCREW-1.4MMDX3MM
44	6520683	HEAD SPRING	89	5559621	COUNTER
45	7780553	SPECIAL SCREW-2MMDX6MM	90	6355721	COUNTER BELT

SYMBOL-NO	P-NO	DESCRIPTION	SYMBOL-NO	P-NO	DESCRIPTION
MISCELLANEOUS			C435	0247003	CERAMIC CHIP 1000PF+-20X
91	6771584	BATTERY TERMINAL HOLDER ASSEMBLY	C436	0247056	CERAMIC CHIP 1500PF+-10X
92	6774781	P.W.B HOLDER	C437LR	0247003	CERAMIC CHIP 1000PF+-20X
93	6292492	VOLUME KNOB	C438	0247039	CERAMIC CHIP 470PF+-5X
94	7765792	SPACER	C439LR	0247039	CERAMIC CHIP 470PF+-5X
95	7766889	SPACER	C441LR	0256372	TANTALUM ELECTROLYTIC 0.22MF+-20X 35V
96	7780901	PAN HEAD SCREW-1.7MMDX4MM	C501	0256155	ELECTROLYTIC 10UF 16V
97	7782842	PAN HEAD SCREW-1.4MMDX6.5MM	C502LR	0256166	ELECTROLYTIC 47MF,4V
98	8722023	FLAT SCREW-1.4MMDX3MM	C503LR	0256166	ELECTROLYTIC 47MF,4V
99	8712024	PAN HEAD SCREW-1.4MMD x 3MM	C504LR	0247007	CERAMIC CHIP 0.01UF+-20X
100	6774831	LED HOLDER	C505LR	0256162	ELECTROLYTIC 220MF 4V
CAPACITORS			C506	0256162	ELECTROLYTIC 220MF 4V
C401LR	0256366	TANTALUM 1.0UF 35V	C601	0256366	TANTALUM 1.0UF 35V
C402LR	0247006	CERAMIC CHIP 0.01MF+80-20X	C602	0247066	CERAMIC CHIP 0.033MF+-10X
C403LR	0247061	CERAMIC CHIP 4700PF+-10X	C603	0256395	TANTALUM ELECTROLYTIC 47MF 3V
C404LR	0256153	ELECTROLYTIC 3.3UF 50V	C604	0256391	TANTALUM ELECTROLYTIC 22MF 3.15V
C405L	0256151	ELECTROLYTIC 1.0UF 50V	C605	0256162	ELECTROLYTIC 220MF 4V
C405R	0256366	TANTALUM 1.0UF 35V	C606	0247003	CERAMIC CHIP 1000PF+-20X
C406LR	0256366	TANTALUM 1.0UF 35V	C607	0256391	TANTALUM ELECTROLYTIC 22MF 3.15V
C408LR	0256155	ELECTROLYTIC 10UF 16V	RESISTORS		
C409LR	0256151	ELECTROLYTIC 1.0UF 50V	RT401	5007441	SEMI VARIABLE 100 OHM
C410LR	0247062	CERAMIC CHIP 6800PF+-10X	RV401	5008821	VARIABLE RESISTOR 10KOHM(A)
C411LR	0247037	CERAMIC CHIP 330PF+-5X	R001-013	0127972	CHIP JUMPER RESISTOR
C412LR	0247030	CERAMIC CHIP 82PF+-5X	R403R	0127933	CHIP RESISTOR 680 OHM+-5X
C413LR	0247003	CERAMIC CHIP 1000PF+-20X	R404R	0127951	CHIP RESISTOR 22KOHM+-5X
C414LR	0256154	ELECTROLYTIC 4.7UF 25V	R405R	0127936	CHIP RESISTOR 1.2KOHM+-5X
C415LR	0256155	ELECTROLYTIC 10UF 16V	R409R	0127943	CHIP RESISTOR 4.7KOHM+-5X
C416LR	0256162	ELECTROLYTIC 220MF 4V	R414LR	0127946	CHIP RESISTOR 8.2KOHM+-5X
C417LR	0256161	ELECTROLYTIC 22MF 6.3V	R418R	0127950	CHIP RESISTOR 18KOHM+-5X
C418	0256154	ELECTROLYTIC 4.7UF 25V	R419	0127947	CHIP RESISTOR 10KOHM+-5X
C419LR	0256166	ELECTROLYTIC 47MF 4V	R422LR	0127963	CHIP RESISTOR 220KOHM+-5X
C420	0256162	ELECTROLYTIC 220MF 4V	R424R	0127943	CHIP RESISTOR 4.7KOHM+-5X
C421	0247003	CERAMIC CHIP 1000PF+-20X	R425	0127947	CHIP RESISTOR 10KOHM+-5X
C422	0247035	CERAMIC CHIP 220PF+-5X	R428R	0127937	CHIP RESISTOR 1.5KOHM+-5X
C423	0247062	CERAMIC CHIP 6800PF+-10X	R430LR	0127911	CHIP RESISTOR 10 OHM+-5X
C424	0256391	TANTALUM ELECTROLYTIC 22MF,3.15V	R432R	0127944	CHIP RESISTOR 5.6KOHM+-5X
C425LR	0247007	CERAMIC CHIP 0.01UF+-20X	R602	0127947	CHIP RESISTOR 10KOHM+-5X
C426LR	0247061	CERAMIC CHIP 4700PF+-10X	R603	0127944	CHIP RESISTOR 5.6KOHM+-5X
C427LR	0256386	TANTALUM ELECTROLYTIC 10MF,3.15V	SEMI-CONDUCTORS		
C428LR	0256166	ELECTROLYTIC 47MF,4V	D401	5329302	MICRO PACKAGE DIODE MA152WA
C429LR	0247003	CERAMIC CHIP 1000PF+-20X	D602	5331591	DIODE 1SS133HV
C430LR	0256151	ELECTROLYTIC 1.0UF 50V	IC401LR	5355701	IC #PC12176
C431LR	0256155	ELECTROLYTIC 10UF 16V	IC501	5355691	IC BA5204
C432	0247057	CERAMIC CHIP 2200PF+-10X	IC601	5355872	IC PST517
C433LR	0247061	CERAMIC CHIP 4700PF+-10X	LED1	5380621	LED SLC-22UR
C434LR	0247059	CERAMIC CHIP 0.022MF+-20X			

SYMBOL-NO	P-NO	DESCRIPTION	SYMBOL-NO	P-NO	DESCRIPTION
SEMI-CONDUCTORS			L501	5152472	CHOKE COIL 100 MICRO H
Q401	5329043	MICRO PACKAGE TRANSISTOR 2SC1623(L5-6)	L602	5152561	CHOKE COIL 68 MICR H
Q402LR	5329192	MICRO PACKAGE TRANSISTOR 2SC2462D	MISCELLANEOUS		
Q403LR	5329043	MICRO PACKAGE TRANSISTOR 2SC1623(L5-6)	JK401	5673491	JACK-3,5MMD (MIC)
Q404	5329043	MICRO PACKAGE TRANSISTOR 2SC1623(L5-6)	JK501,502	5679942	JACK (PHONES A, B)
Q405	5323011	TRANSISTOR 2SC2603E	JK601	5672091	DC JACK (TAPE)
Q601	5329681	MICRO PACKAGE TRANSISTOR 2SB1001	S401	5622461	SLIDE SWITCH
Q602	5329043	MICRO PACKAGE TRANSISTOR 2SC1623(L5-6)	S402	5603432	LEAF SWITCH (REC)
COILS			S403	5622451	SLIDE SWITCH (TONE)
L401LR	5152652	CHOKE COIL	S404	5622481	SLIDE SWITCH (RIF)
L402	5261232	BIAS OSCILLATOR COIL	S601	5622481	SLIDE SWITCH (PAUSE)
			S602	5603432	LEAF SWITCH (POWER)

## ERASE HEAD REPLACEMENT

Replace the erase head according to the procedure shown below.

1. Replace the erase head with the new one specified as replacement parts.

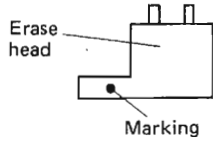

Erase heads in mass production products: Red, Blue or Black marking

Erase heads as replacement parts: No marking

2. Unsolder sections (A), (B), (C) and (D) shown below.

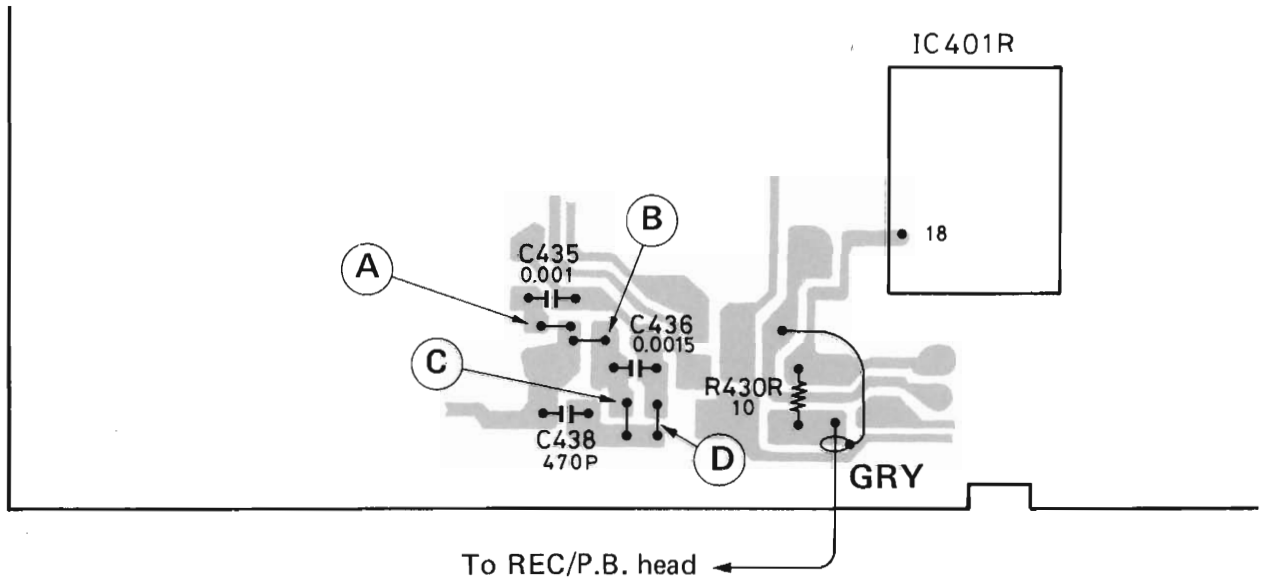

3. Solder section (E) shown below.

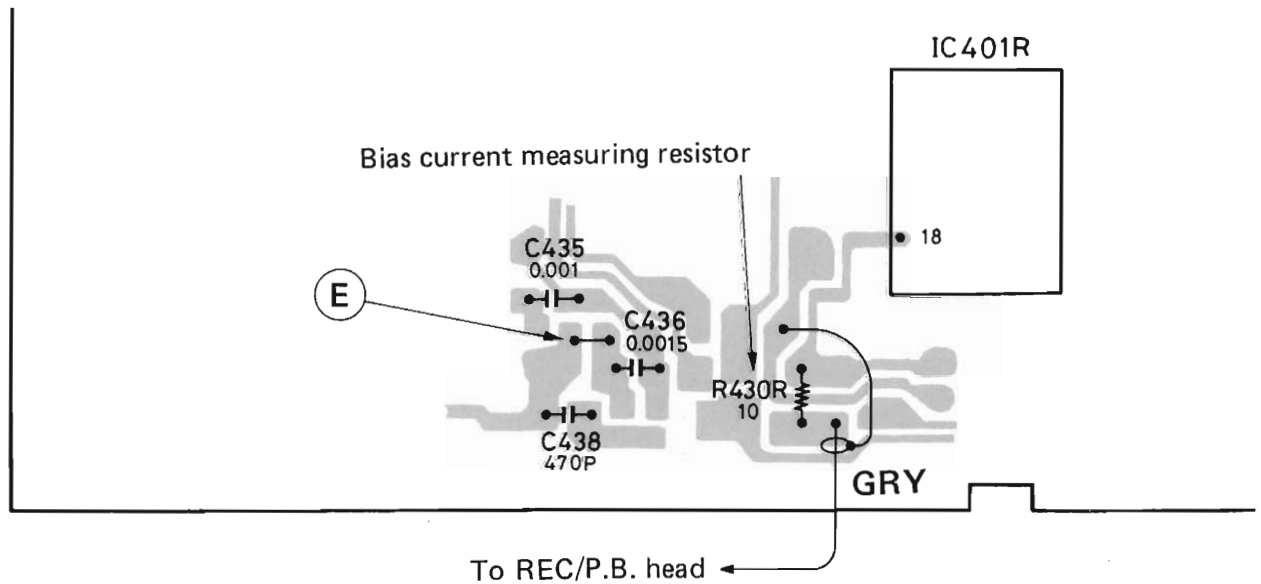

4. Re-adjust the record bias current according to Step 3 in page 58 "ADJUSTMENT".



# DOLBY /GRAPHIC EQUALIZER CP-91EQ

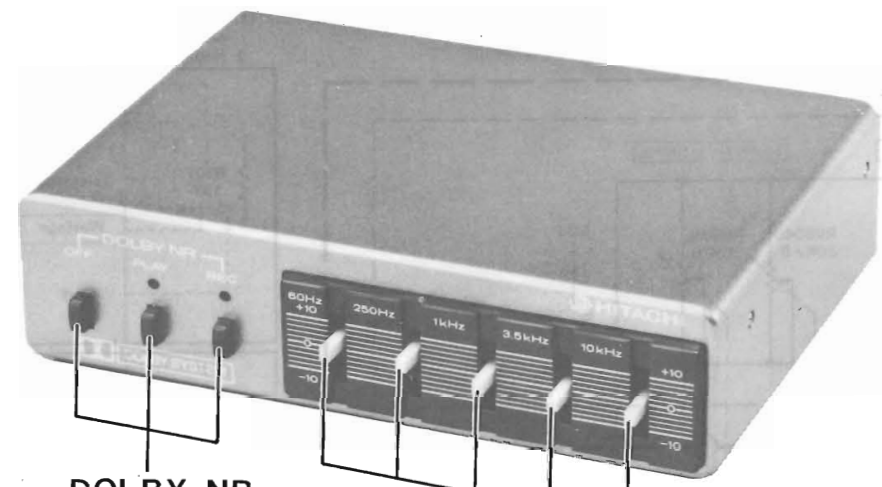

DOLBY NR SWITCHES

GRAPHIC EQUALIZER CONTROLS

### SPECIFICATIONS

- |  |  |
|--|--|
| Equalizer Frequencies: 60 Hz, 250 Hz, 1 kHz, 3.5 kHz, 10 kHz | Current Consumption: 45 mA (with no signal)            |
| Adjustment Range: ±10 dB                                     | Semiconductors: 3 ICs, 4 transistors, 3 diodes, 2 LEDs |
| Gain: 0 dB   | Dimensions: 120(W) x 33.5(H) x 80(D) mm                |
| Signal to Noise Ratio: 80 dB                                 | Weight: 200 g  |
| Distortion: 1 kHz, 0.5%                                      |  |

### CONNECTORS

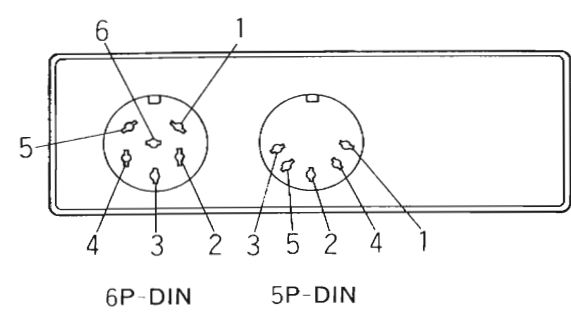

Connector	Terminal	Input/Output
5P DIN socket	1	L Decoder output/Encoder input
	2	GND
	3	R Decoder input/Encoder output
	4	R Decoder output/Encoder input
	5	L Decoder input/Encoder output
6P DIN socket	1	R Equalizer output
	2	R Equalizer input
	3	L Equalizer output
	4	+12V Power supply
	5	L Equalizer input
	6	GND

### BLOCK DIAGRAM

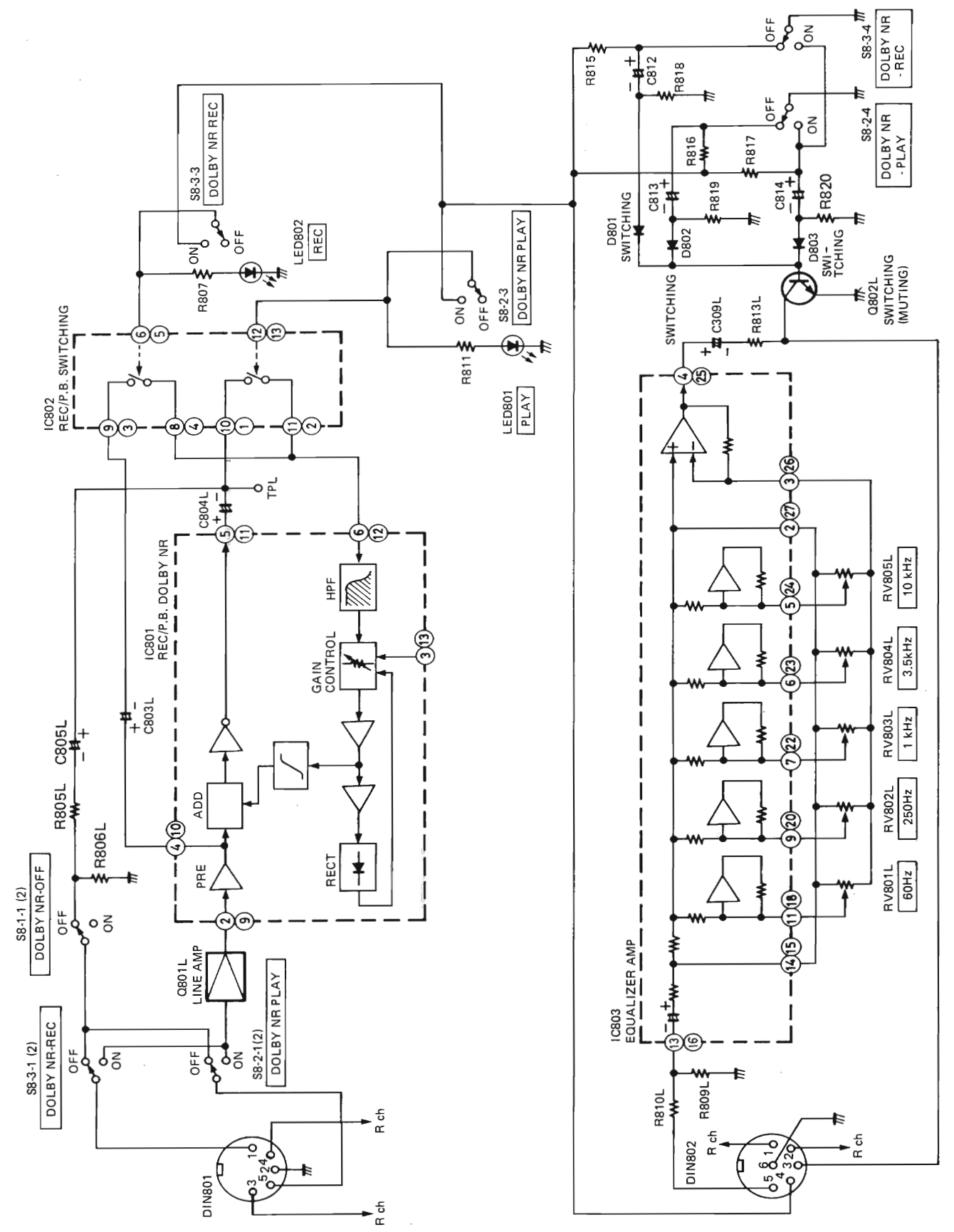

SCHMATIC DIAGRAM

Q801L,R  
2SC1740LNR  
LINE AMP

IC801  
TA3003S  
REC./P.B.  
DOLBY NR

IC802  
HD14066B  
REC./P.B.  
SWITCH

LED801  
SLP214B  
PLAY

LED802  
SLP114B  
REC

IC803  
EA1010  
EQ. AMP

D801  
ISS133-HV  
SWITCHING

D802  
ISS133-HV  
SWITCHING

D803  
ISS133-HV  
SWITCHING

Q802L,R  
2SC2603E  
SWITCHING  
(MUTING)

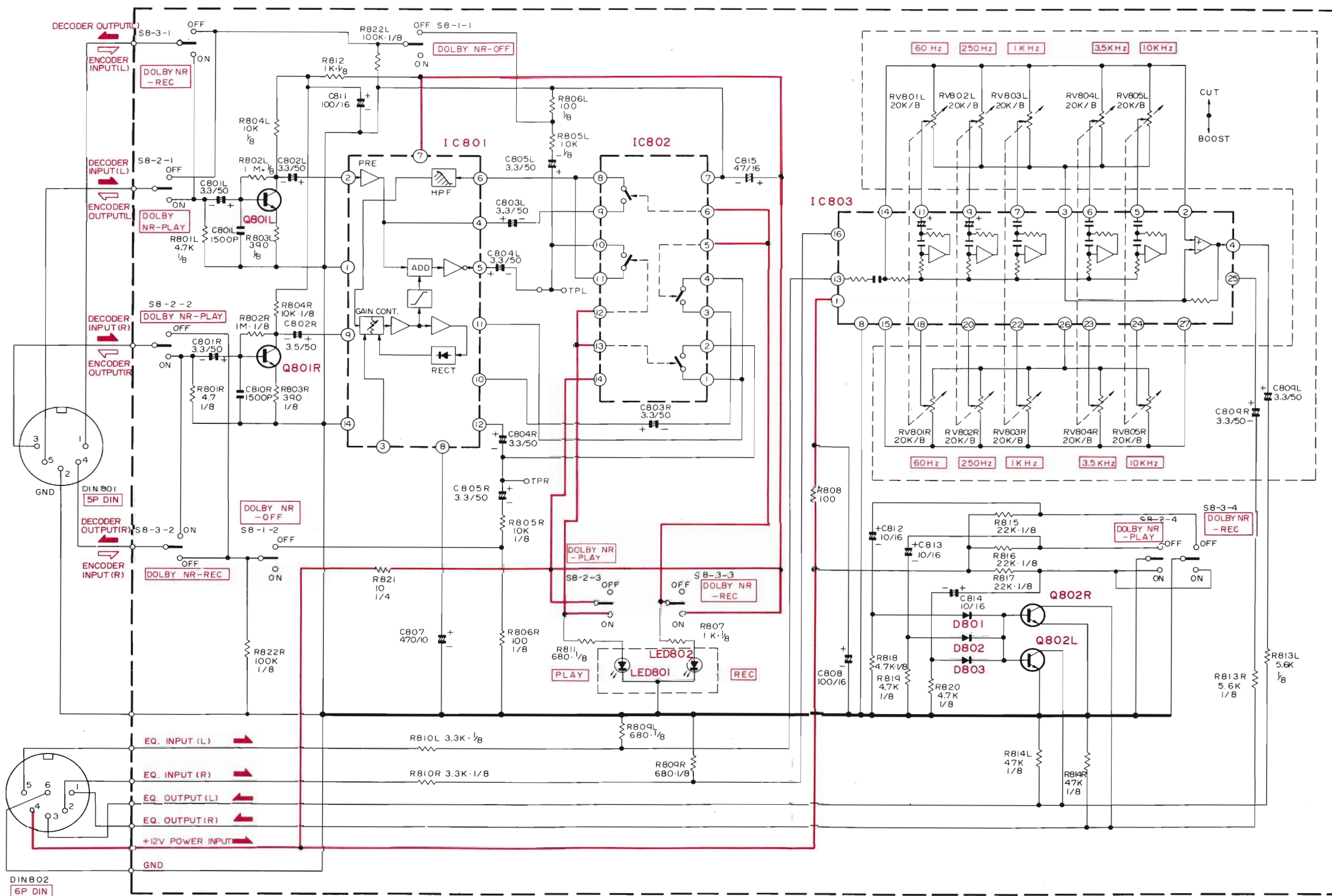

Note

1. Voltage measured at base of chassis with minimum volume control and no signal.
2. Nomenclature of Resistors and Capacitors.

		Circuit No.	
R101 150-K	Value	No indicated	Ω(Ohm)
	Tolerance	No indicated	±5%
	Wattage	No indicated	¼W
RS-1-K	Sort	No indicated	Carbon film
			RC : Composition RW : Wire wound RS : Oxide metal film RN : Fixed metal film

		Circuit No.	
C101 0.001-M	Value	No indicated	µF
	Tolerance	No indicated	±10%
	Sort		Ceramic
C102 0.1/16	Voltage		Electrolytic
			Mylar
			Polyester
			Styrol

3. Be sure to make your orders of resistors and capacitors with value, voltage, tolerance and sort.
4. When replacing capacitors marked with \*, use specified ones stated on parts list since required temperature characteristics.

CIRCUIT BOARD DIAGRAM

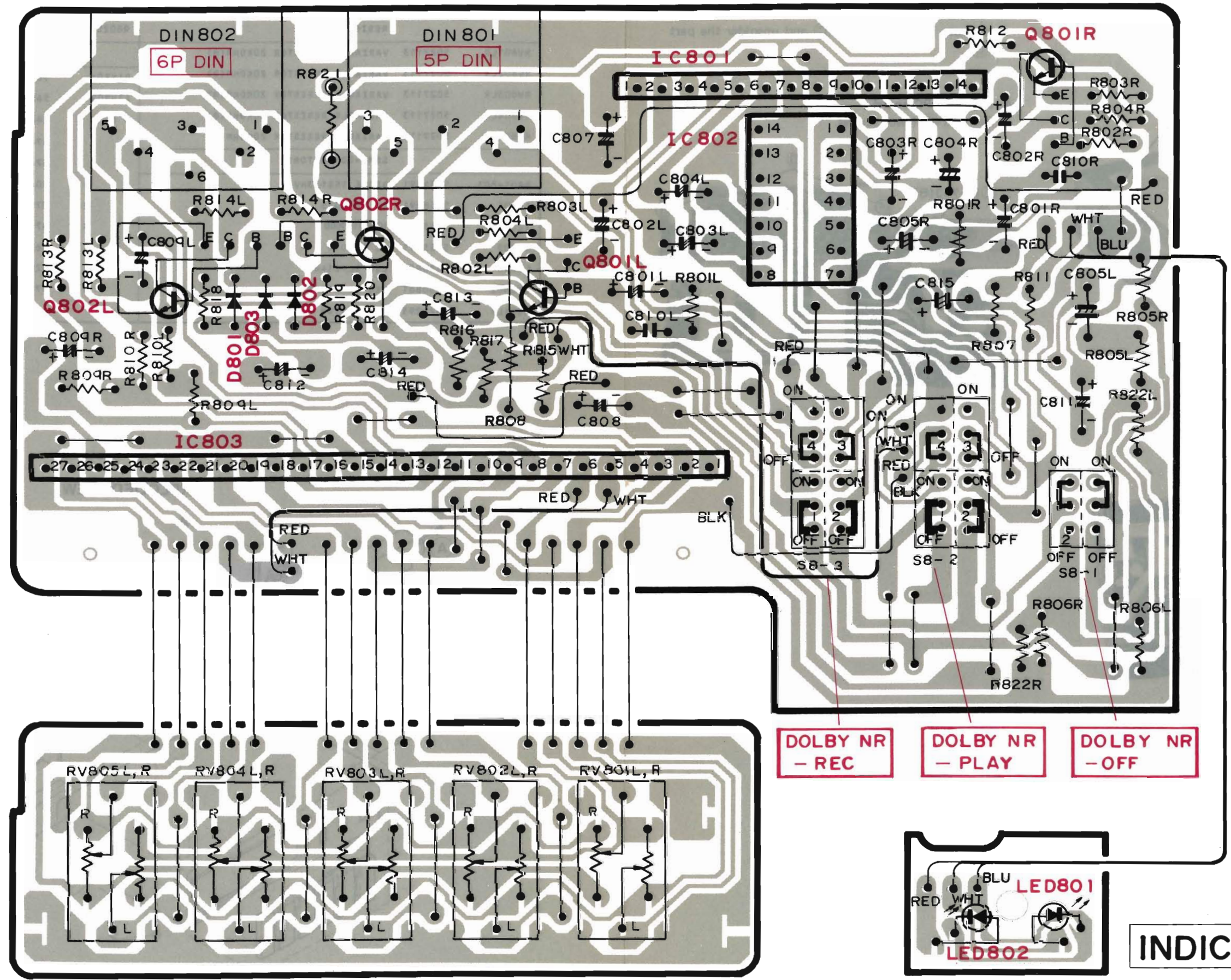

MAIN

VOLUME

INDICATOR

10KHz
3.5KHz
1KHz
250Hz
60Hz

DISASSEMBLY

1. Case

Remove (A) (five) screws and pull the chassis in the direction of the arrow.

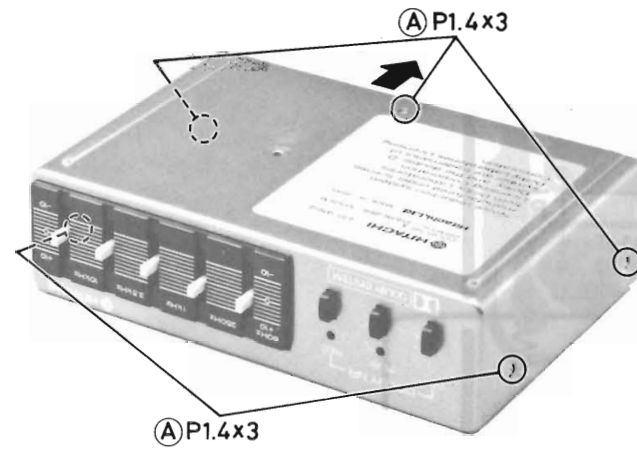

2. Main PC board

Remove (B) (two) screws.

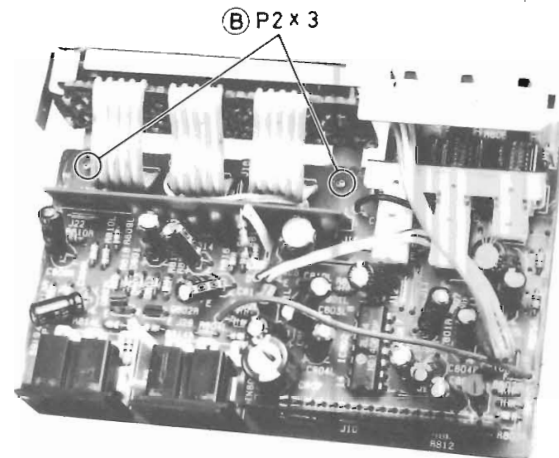

3. Volume PC board

Release locking the tab (C) and unsolder the part (D).

4. Indicator PC board

Remove (E) (two) screws.

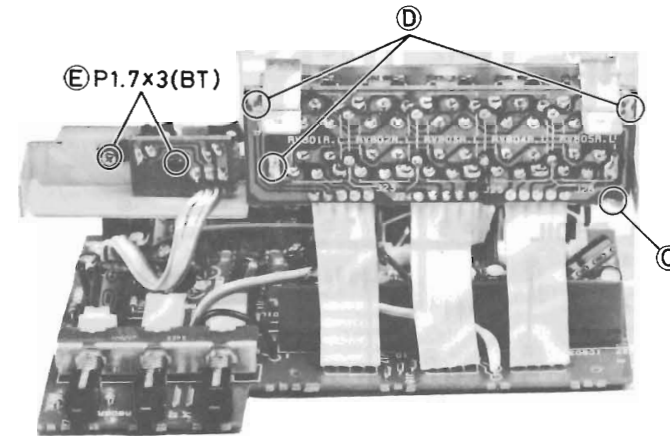

REPLACEMENT PARTS LIST

SYMBOL-NO	P-NO	DESCRIPTION	SYMBOL-NO	P-NO	DESCRIPTION
		RESISTORS	Q802LR	5323011	TRANSISTOR 2SC2603E
RV801LR	5027113	VARIABLE RESISTOR 20KOHM(B)			MISCELLANEOUS
RV802LR	5027113	VARIABLE RESISTOR 20KOHM(B)	DIN801	5653791	5P DIN SOCKET
RV803LR	5027113	VARIABLE RESISTOR 20KOHM(B)	DIN802	5653861	6P DIN SOCKET
RV804LR	5027113	VARIABLE RESISTOR 20KOHM(B)	S 8	5634554	PUSH SWITCH (DOLBY NR-OFF/PLAY/REC)
RV805LR	5027113	VARIABLE RESISTOR 20KOHM(B)		5746942	6P DIN CORD
		SEMI-CONDUCTORS		5746962	5P DIN CORD
D801-803	5331591	DIODE 1SS133HV	1	6037932	FRONT CASE ASSEMBLY
IC801	5358091	IC TA3003S	2	8712024	PAN HEAD SCREW-1.4MMD x 3MM
IC802	5365491	IC HD14066B	3	8711103	PAN HEAD SCREW-2MMDX3MM
IC803	5355411	IC EA1010	4	8612001	BT PAN HEAD SCREW-1.7MMDX3MM
LED801	5380882	LED SLP214B	5	6293471	PUSH BUTTON
LED802	5380881	LED SLP-114B	6	6771541	LED HOLDER
Q801LR	5321293	TRANSISTOR 2SC1740LN-R			

EXPLODED VIEW

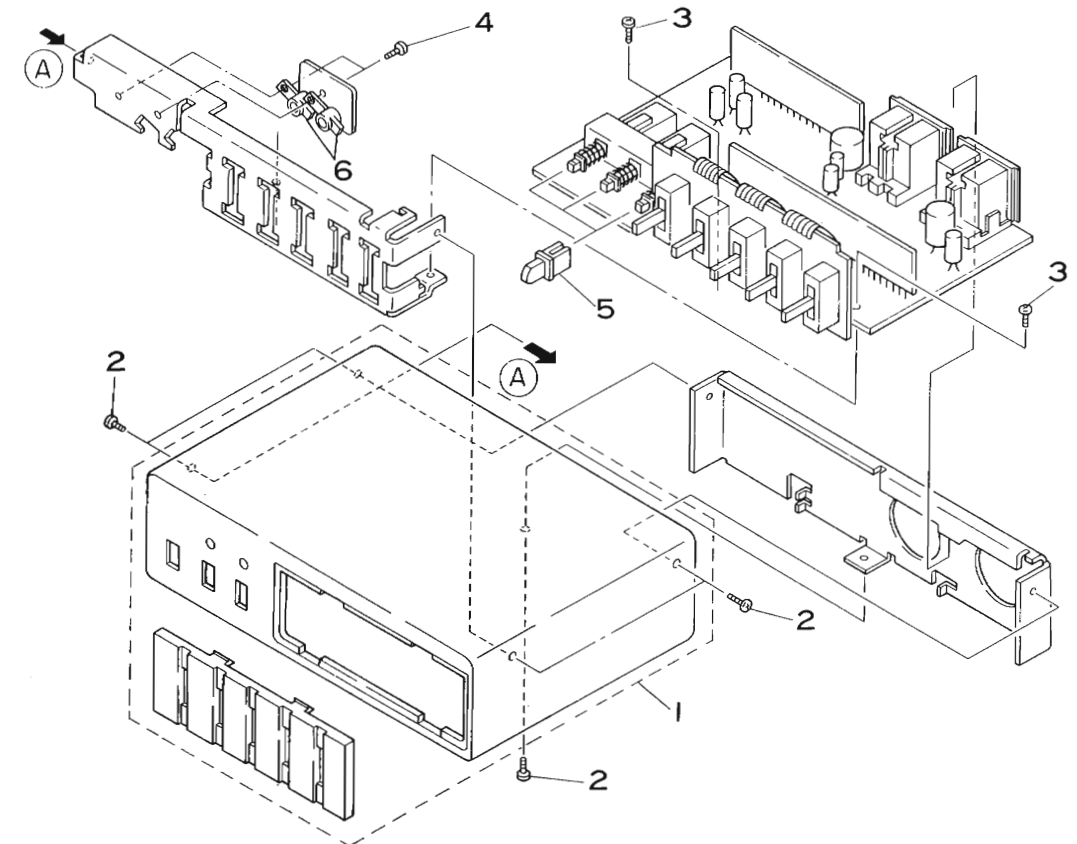

Note: Components marked without numbers in this drawing are not specified as replacement parts.

# STEREO CASSETTE PLAYER CP-91DEX

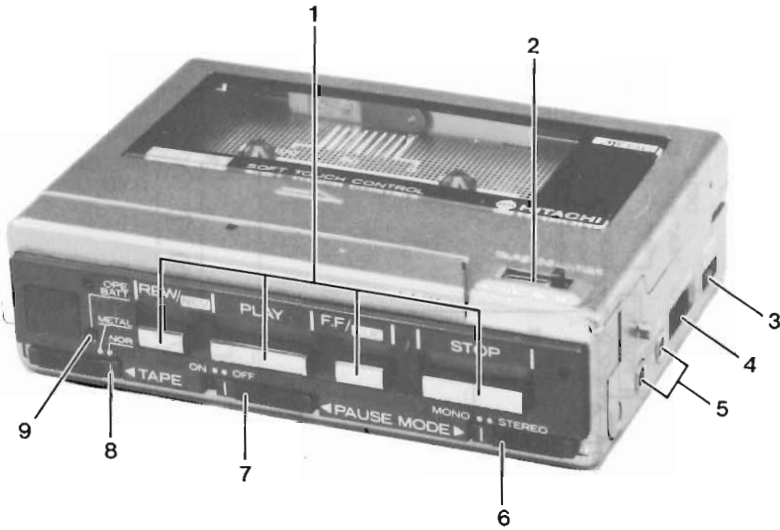

## KEY TO ILLUSTRATIONS

1. OPERATION BUTTONS
2. TAPE COUNTER
3. TONE SWITCH
4. VOLUME CONTROL
5. HEADPHONE SOCKETS
6. MODE SWITCH
7. PAUSE SWITCH
8. TAPE SELECT SWITCH
9. OPERATION/BATTERY INDICATOR

## SPECIFICATIONS

Tape: Cassette tape (C-30, 60, 90)  
 Track System: 4 track 2 channel stereo  
 Tape Speed: 4.75 cm/s  
 Frequency Response: Normal: 50 to 12,000 Hz  
 Metal: 50 to 14,000 Hz  
 S/N (Signal to Noise Ratio): 50 dB  
 Cross Talk: 50 dB (Between tracks)  
 30 dB (Between channels)  
 Distortion: 2%

Wow and Flutter: 0.2% (WRMS)  
 Output Impedance: Headphones: 8 ~ 300 ohms  
 Power Output: 30 mW + 30 mW (T.H.D. 10%)  
 Power Supply: DC 3V ("AA" cell or IEC R6x2)  
 Current Consumption: 160 mA (with no signal)  
 Semiconductors: 4 ICs, 2 transistors, 2 diode, 1 LED  
 Motor: DC micromotor  
 Dimensions: 120(W) x 33.5(H) x 80(D) mm  
 Weight: 320 g (with batteries)

## CONNECTORS

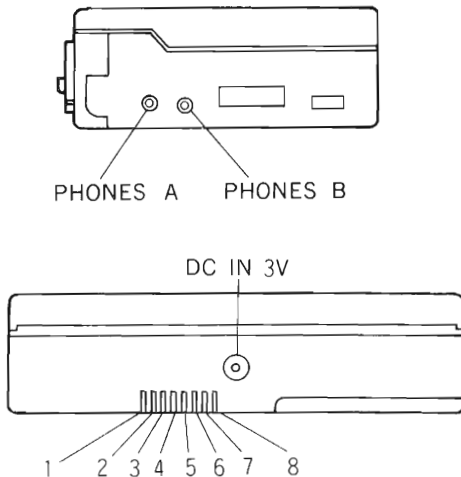

System CP-900S		
Connector	Terminal	Input/Output
8P Pin Connector	1	R Signal output
	2	L Signal output
	3	GND
	4	+3V power input
	5, 6	Blank
	7	Motor GND
	8	Motor +B
	Independently	
Connector	Terminal	Input/Output
PHONES	A	Headphone output (stereo)
	B	Headphone output (stereo)
DC IN 3V		+3V power input

BLOCK DIAGRAM

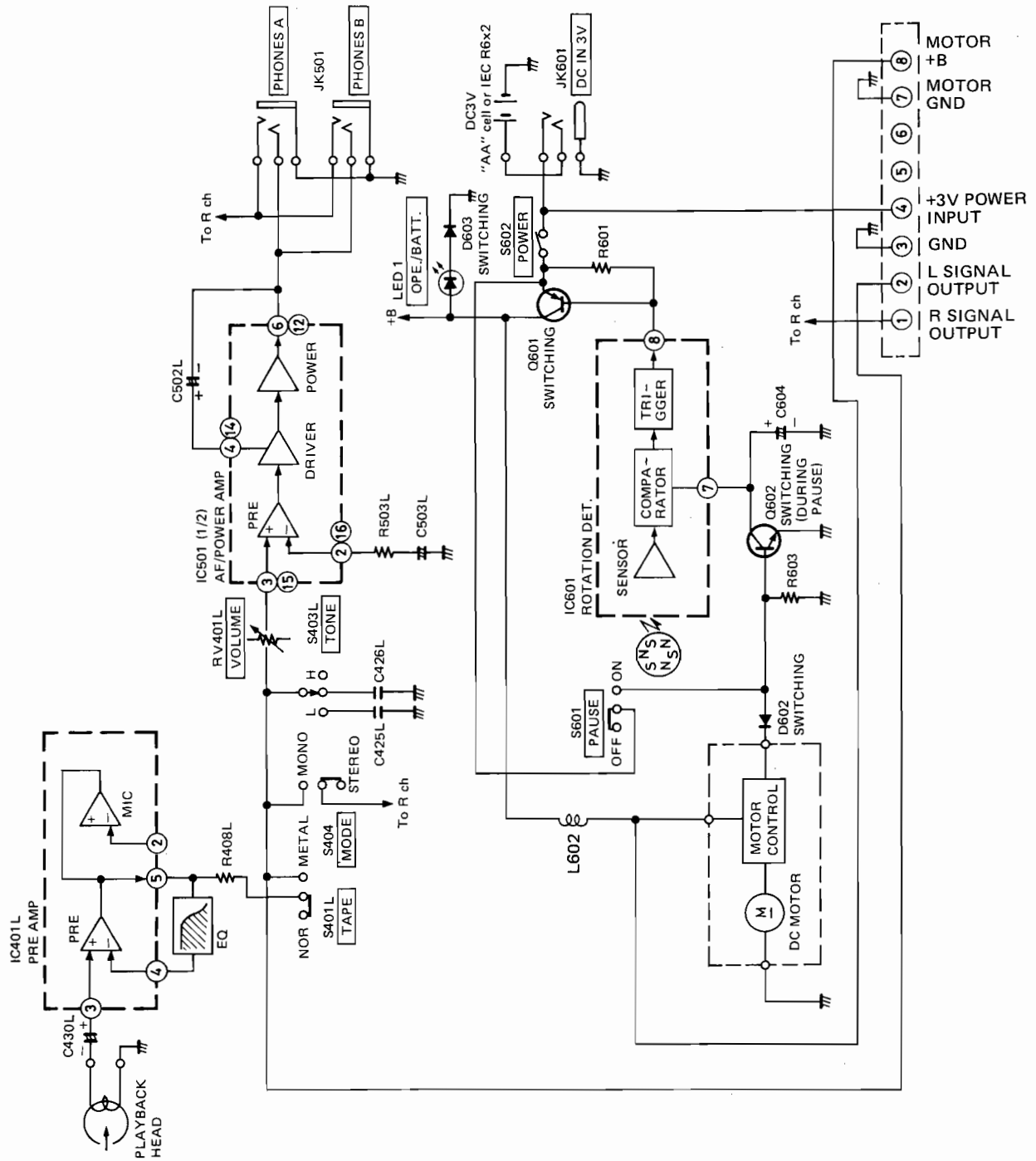

**DISASSEMBLY**

1. **Cassette lid**  
Remove (A) (three) screws.

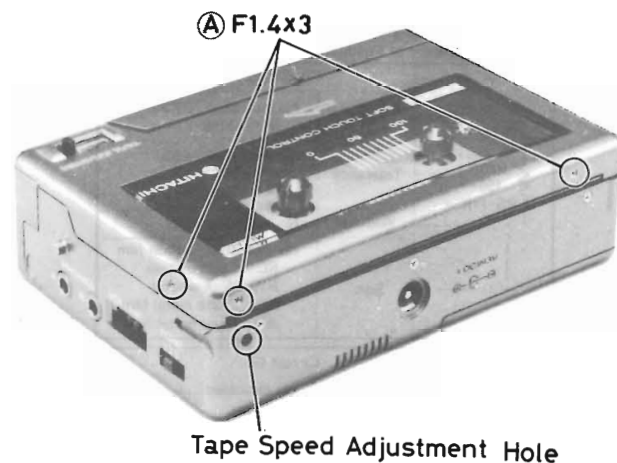

4. **Main PC board**  
Remove (D) (three) screws.

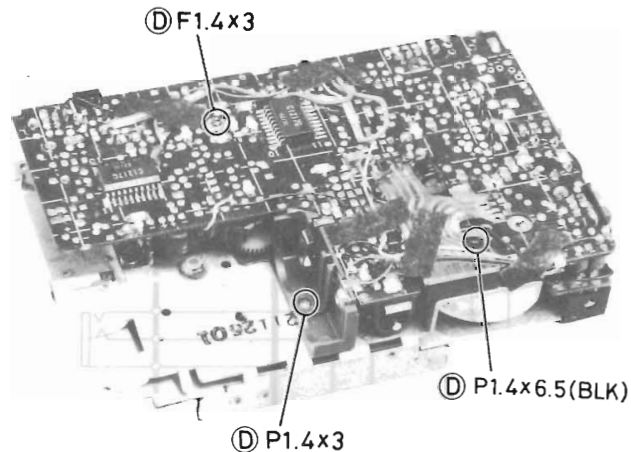

2. **Escutcheon**  
Remove (B) (five) screws.

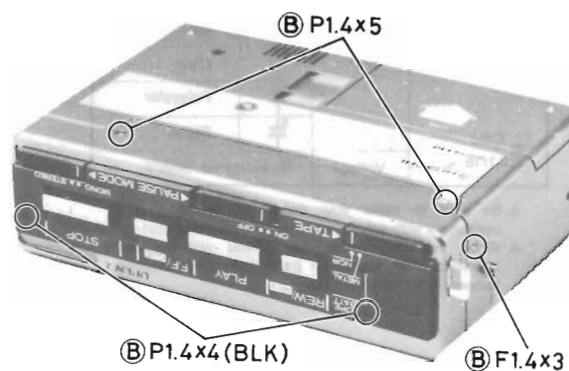

5. **Decoration metal**  
Remove (E) (two) screws.

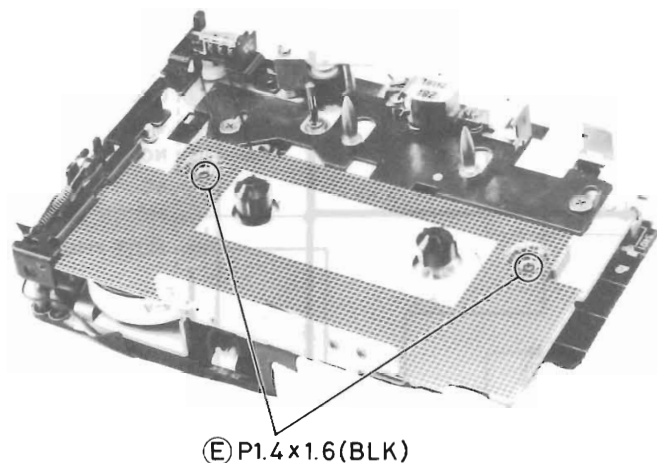

3. **Rear case**  
Open the battery lid and remove (C) (four) screws. Then take out the chassis from the rear case by carefully lifting the tape selector side of the chassis.

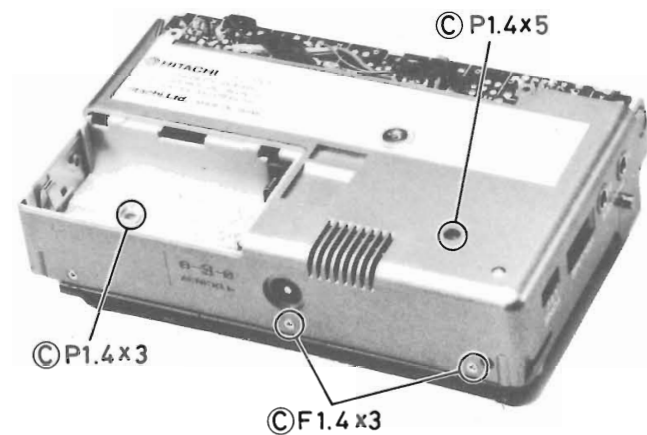

6. **Eject/counter holder**  
Remove (F) (two) screws.

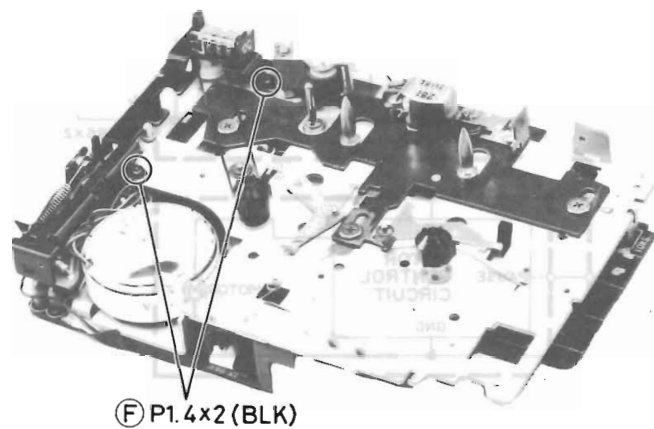

**ADJUSTMENT**

Perform the following adjustments in the sequence stated after cleaning the head, pressure roller, and capstan with a head cleaning stick moistened in alcohol.

Step	Adjustment Item	Measuring Instrument and Connection			Check Tape	Mode	Adjusted Position	Adjusted Value	Remarks
		Measuring Instrument	Input Terminal	Output Terminal					
1	Tape speed	• Frequency counter	—	Head-phone socket	Tape speed test tape (3,000Hz)	Playback	Semivariable resistor in the motor PC board	3,005Hz ±10Hz	Note 1
2	Head azimuth	• VTVM	—	Head-phone socket	Head azimuth test tape (10kHz)	Playback	Azimuth adjusting screw	Output Max.	Note 2

**Note:**

- Adjust within 30 sec. after heat-running for more than 20 minutes.
- When the maximum values of both channels are different, adjust to the maximum value of the L channel. In this case, the difference between the maximum values of both channels should be within 2 dB.

**INSPECTION OF MECHANISM**

Item	Checking item	Reference value	Remarks	
1	Pressure of pressure roller	200 g ± 40 g	Note 1	
2	Take-up torque	30 ~ 65 g.cm	Measure in cassette torque meter	
3	Fast forward torque	55 g.cm or more		
4	Rewind torque	55 g.cm or more	Measure without tape counter	
5	Back tension torque	Take-up		2 g. cm or less
		Supply	4.5 g.cm or less	
6	Button operation force	Play button	0.3 kg or less	Measure without leaf switch (Power)
		Fast forward button	0.8 kg or less	
		Rewind button	0.5 kg or less	
		Stop button	0.5 kg or less	
7	Flywheel thrust gap	0.1 ~ 0.2 mm		

**Note:**

- Set this unit in the playback mode and press the pressure roller in the direction of the arrow using a fan type tension gauge, and measure the pressure when the pressure roller is released from the capstan.

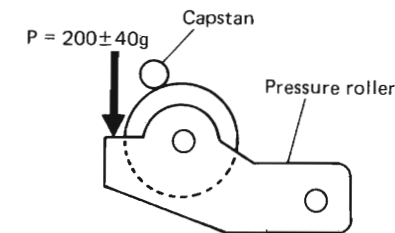

**LUBRICATION:** Refer to CP-90DEX

SCHMATIC DIAGRAM

IC401L,R  
μPC1217G  
PRE AMP

IC501  
BA5204  
AF/POWER  
AMP

D602  
ISS133HV  
SWITCHING

Q602  
2SC1623  
SWITCHING  
(PAUSE)

IC601  
PST517  
ROTATION  
DET.

D603  
MAI52WA  
SWITCHING

LED1  
SLC22UR  
OPE.,BATT.

Q601  
2SB1001  
SWITCHING  
(POWER)

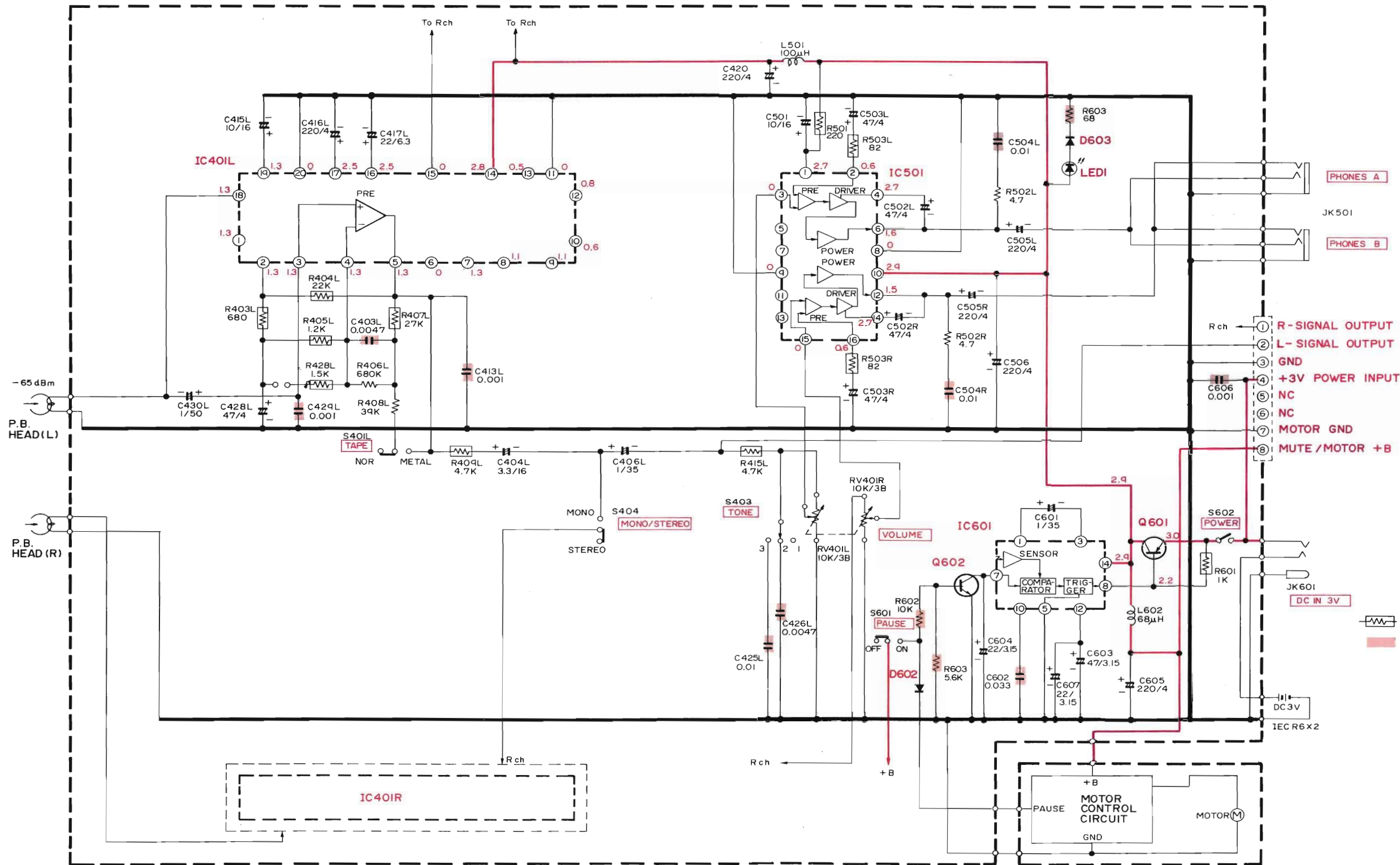

Note

1. Voltage measured at base of chassis with minimum volume control and no signal.
2. Nomenclature of Resistors and Capacitors.

Circuit No.	
Value	No indicated Ω (Ohm) M: 1000 kΩ
Tolerance	No indicated ±5% K: ±10% M: ±20%
Wattage	No indicated ¼W
Sort	No indicated Carbon film RC: Composition RW: Wire wound RS: Oxide metal film RN: Fixed metal film

Circuit No.	
Value	No indicated μF P: PF
Tolerance	No indicated ±10% J: ±5% M: ±20% Z: +80%, -20% D: ±0.5pF C: ±0.25pF
Sort	Ceramic Electrolytic Mylar Polyester Styrol
Voltage	No indicated 50WV

3. Be sure to make your orders of resistors and capacitors with value, voltage, tolerance and sort.
4. When replacing capacitors marked \*, use specified ones stated on parts list since required temperature characteristics.

PRINTED RESISTORS  
CHIP PARTS



CIRCUIT BOARD DIAGRAM

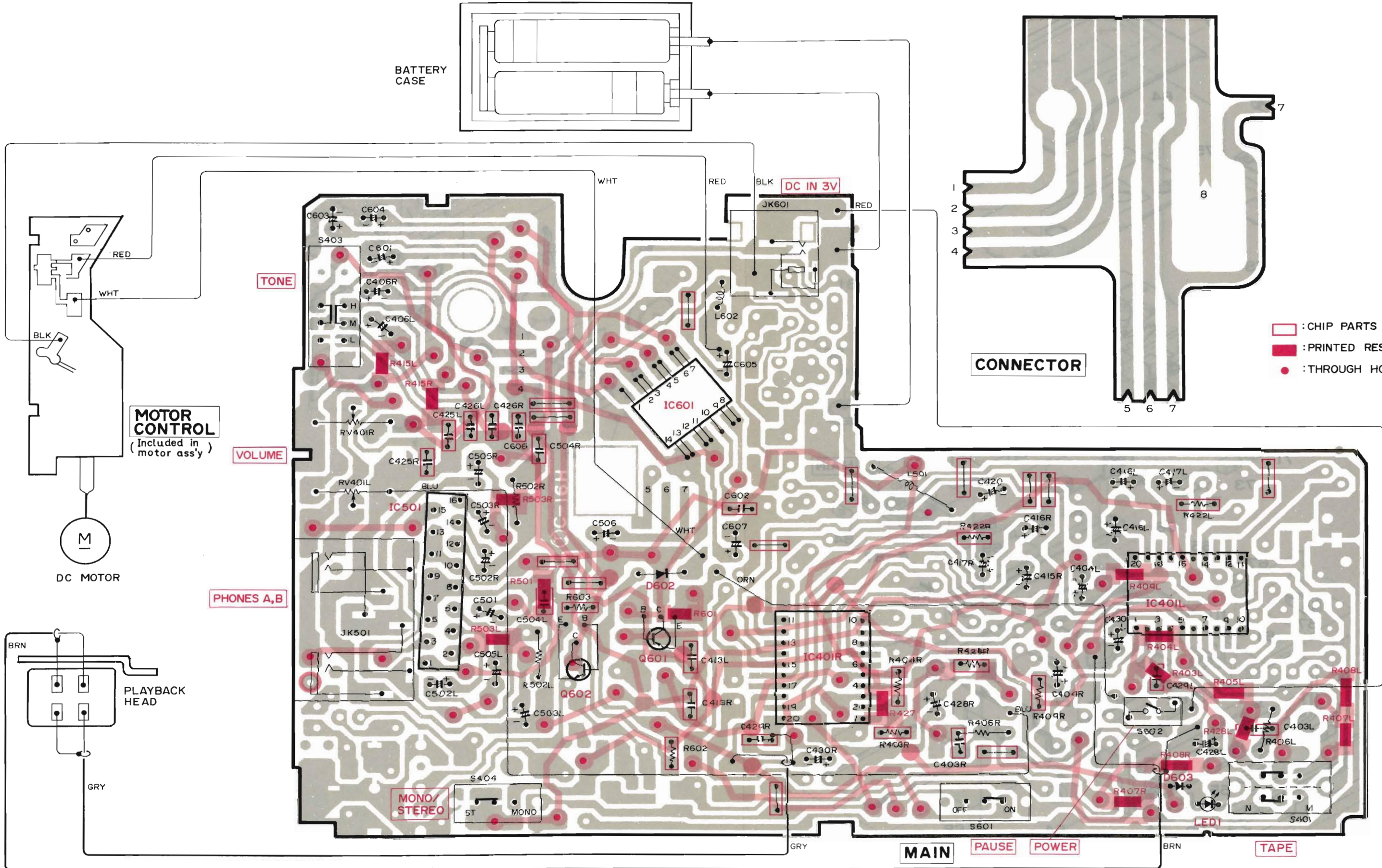

EXPLODED VIEW (Cabinet)

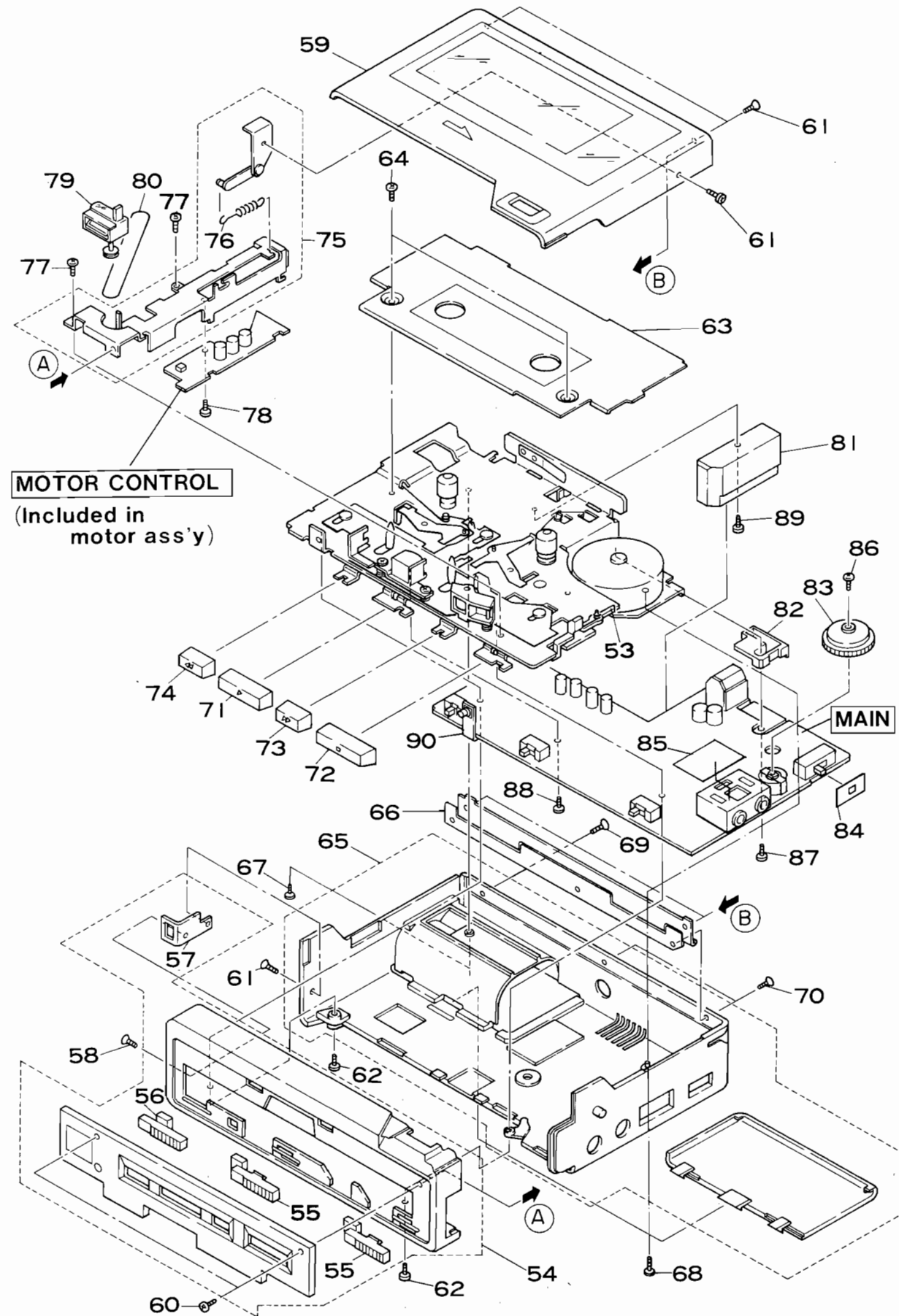

**MOTOR CONTROL**  
(Included in motor ass'y)

**MAIN**

EXPLODED VIEW (Mechanism - SR - 1B)

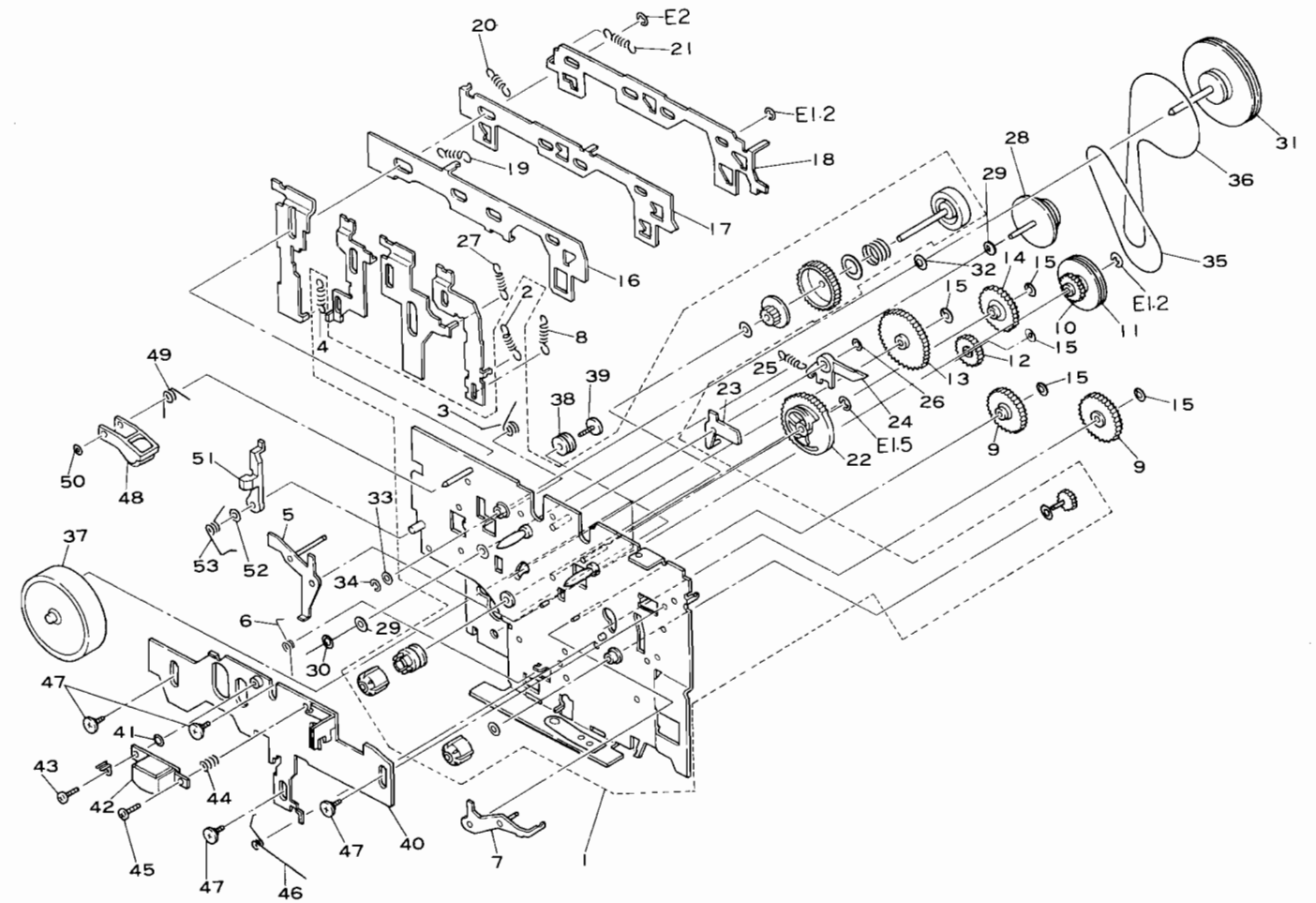











Note: Components marked without numbers in this drawing are not specified as replacement parts.

## REPLACEMENT PARTS LIST

SYMBOL-NO	P-NO	DESCRIPTION	SYMBOL-NO	P-NO	DESCRIPTION
MECHANISM (SR - 1B)			46	6548516	HEAD PLATE SPRING
1	7044232	SUB CHASSIS ASSEMBLY	47	7782822	SPECIAL SCREW
2	6543124	SPRING	48	6774491	PRESSURE ROLLER ARM ASSEMBLY
3	6548487	SPRING	49	6548533	SPRING
4	6543072	SPRING	50	7787563	POLY SLIDER WASHER
5	7350761	F.F ARM ASSEMBLY	51	6774581	REVIEW/CUE ARM
6	6548521	SPRING	52	7787563	POLY SLIDER WASHER
7	7350781	REWIND ARM ASSEMBLY	53	6548605	SPRING
8	6543091	SPRING	MISCELLANEOUS		
9	6432491	REWIND IDLER GEAR	54	6244852	ESCUTCHEON ASSEMBLY
10	6432462	GEAR	55	6293441	SLIDE KNOB(PAUSE, MODE)
11	6423032	MIDDLE PULLEY	56	6293401	SLIDE KNOB(TAPE)
12	6432442	PAUSE IDLER GEAR	57	7351541	STRAP HOLDER
13	6432451	F.F IDLER GEAR	58	8722005	FLAT SCREW-1.4MMDX3MM
14	6432621	POWER ASSIST IDLER GEAR	59	6094324	CASSETTE LID ASSEMBLY
15	7787571	WASHER	60	8714005	PAN HEAD SCREW-1.4MMDX4MM
16	7350712	REVIEW/CUE PLATE	61	8722005	FLAT SCREW-1.4MMDX3MM
17	7350722	LOCK PLATE	62	8712027	PAN HEAD SCREW-1.4MMDX5MM
18	7354021	SWITCH PLATE	63	6636732	DECORATION METAL
19	6543131	SPRING	64	8714022	PAN HEAD SCREW-1.4MMDX1.6MM
20	6543111	SPRING	65	6037204	REAR CASE ASSEMBLY
21	6543082	SPRING	66	6337512	HINGE ASSEMBLY
22	6432524	POWER ASSIST CAM GEAR	67	8712024	PAN HEAD SCREW-1.4MMDX3MM
23	6774461	PLAY LOCK ARM	68	8712027	PAN HEAD SCREW-1.4MMDX5MM
24	6774471	TRIGGER ARM	69	8722004	FLAT SCREW-1.4MMDX2MM
25	6542514	SPRING	70	8722005	FLAT SCREW-1.4MMDX3MM
26	7788591	WASHER	71	6058033	BUTTON(PLAY)
27	6543151	SPRING	72	6058034	BUTTON(STOP)
28	6423053	ANTI PULLEY ASSEMBLY	73	6058023	BUTTON (F.F)
29	7778854	PLAY IDLER GEAR	74	6058024	BUTTON(REWIND)
30	7786213	WASHER	75	7351694	EJECT/COUNTER HOLDER ASSEMBLY
31	6374292	FLYWHEEL ASSEMBLY	76	6543043	SPRING
32	7772625	SPRING	77	8714023	PAN HEAD SCREW-1.4MMDX2MM
33	7786119	POLY SLIDER WASHER	78	8712024	PAN HEAD SCREW-1.4MMDX3MM
34	7774841	E RING-1.6MMD	79	5559621	COUNTER
35	6355791	BELT	80	6355721	COUNTER BELT
36	6355521	BELT-1.0MMD	81	6771584	BATTERY TERMINAL HOLDER ASSEMBLY
37	5577661	DC MOTOR	82	6774761	P.W.B HOLDER
38	6590271	RUBBER PLATE	83	6292492	VOLUME KNOB
39	7782831	SCREW FOR MOTOR MOUNTING	84	7765792	SPACER
40	7350744	HEAD PLATE ASSEMBLY	85	7766889	SPACER
41	7779923	WASHER	86	7780901	PAN HEAD SCREW-1.7MMDX4MM
42	5449281	RECORD PLAYBACK HEAD	87	7782842	PAN HEAD SCREW-1.4MMDX6.5MM
43	8741103	SCREW (2MMD x 3MM)	88	8722023	FLAT SCREW-1.4MMDX3MM
44	6520683	HEAD SPRING	89	8712024	PAN HEAD SCREW-1.4MMD x 3MM
45	7780553	SPECIAL SCREW-2MMDX6MM	90	6774831	LED HOLDER

SYMBOL-NO	P-NO	DESCRIPTION	SYMBOL-NO	P-NO	DESCRIPTION
<b>CAPACITORS</b>			R403R	0127933	CHIP RESISTOR 680 OHM+-5%
C403LR	0247061	CERAMIC CHIP 4700PF+-10%	R404R	0127951	CHIP RESISTOR 22KOHM+-5%
C404L	0256153	ELECTROLYTIC 3.3UF 50V	R405R	0127936	CHIP RESISTOR 1.2KOHM+-5%
C404R	0256381	TANTALUM ELECTROLYTIC 3.3MF 16V	R409R	0127943	CHIP RESISTOR 4.7KOHM+-5%
C406LR	0256366	TANTALUM 1.0UF 35V	R422LR	0127963	CHIP RESISTOR 220KOHM+-5%
C413LR	0247003	CERAMIC CHIP 1000PF+-20%	R428R	0127937	CHIP RESISTOR 1.5KOHM+-5%
C415LR	0256155	ELECTROLYTIC 10UF 16V	R602	0127947	CHIP RESISTOR 10KOHM+-5%
C416LR	0256162	ELECTROLYTIC 220MF 4V	R603	0127944	CHIP RESISTOR 5.6KOHM+-5%
C417LR	0256161	ELECTROLYTIC 22MF 6.3V	<b>SEMI-CONDUCTORS</b>		
C42LR	0256166	ELECTROLYTIC 47MF 4V	D602	5331591	DIODE 1SS133HV
C420	0256162	ELECTROLYTIC 220MF 4V	D603	5329302	MICRO PACKAGE DIODE MA152WA
C425LR	0247007	CERAMIC CHIP 0.01UF+-20%	IC401LR	5355701	IC #PC12176
C426LR	0247061	CERAMIC CHIP 4700PF+-10%	IC501	5355691	IC BA5204
C429LR	0247003	CERAMIC CHIP 1000PF+-20%	IC601	5355872	IC PST517
C430LR	0256386	TANTALUM ELECTROLYTIC 10MF,3.15V	LED1	5360621	LED SLC-22UR
C501	0256155	ELECTROLYTIC 10UF 16V	Q601	5329661	MICRO PACKAGE TRANSISTOR 2SB1001
C502LR	0256166	ELECTROLYTIC 47MF 4V	Q602	5329043	MICRO PACKAGE TRANSISTOR 2SC1623(L5-6)
C503LR	0256166	ELECTROLYTIC 47MF 4V	<b>COILS</b>		
C504LR	0247007	CERAMIC CHIP 0.01UF+-20%	L501	5152472	CHOKE COIL 100 MICRO H
C505LR	0256162	ELECTROLYTIC 220MF 4V	L602	5152561	CHOKE COIL 68 MICRO H
C506	0256162	ELECTROLYTIC 220MF 4V	<b>MISCELLANEOUS</b>		
C601	0256366	TANTALUM 1.0UF 35V	JK501,502	5679942	JACK (PHONES A, B)
C602	0247066	CERAMIC CHIP 0.033MF+-10%	JK601	5672091	DC JACK
C603	0256395	TANTALUM ELECTROLYTIC 47MF 3V	S401	5622461	SLIDE SWITCH (TAPE)
C604	0256391	TANTALUM ELECTROLYTIC 22MF 3.15V	S403	5622451	SLIDE SWITCH (TONE)
C605	0256162	ELECTROLYTIC 220MF 4V	S404	5622481	SLIDE SWITCH (MODE)
C606	0247003	CERAMIC CHIP 1000PF+-20%	S601	5622481	SLIDE SWITCH (PAUSE)
C607	0256391	TANTALUM ELECTROLYTIC 22MF 3.15V	S602	5603432	LEAF SWITCH (POWER)
<b>RESISTORS</b>					
RV401	5008621	VARIABLE RESISTOR 10KOHM(A)			
R001-013	0127972	CHIP JUMPER RESISTOR			

Type of head					
P	Pan head screw		BT	Binding head tapping screw	
F	Flat countersunk head screw		BL	Bolt	
B	Binding head screw		W	Washer	
T	Round head tapping screw		E	"E" ring	
Length (L mm)					
Diameter (D mm)					

When ordering hardware excluding stated on these lists, be sure to make your orders with type and size.



**HITACHI SALES CORPORATION OF AMERICA****Eastern Regional Office**

1200 Wall Street West, Lyndhurst, New Jersey 07071,  
U.S.A.

Tel. 201-935-8980

**Mid-Western Regional Office**

1400 Morse Ave., Elk Grove Village, Ill. 60007, U.S.A.

Tel. 312-593-1550

**Southern Regional Office**

510 Plaza Drive, College Park, Georgia 30349, U.S.A.

Tel. 404-763-0360

**Western Regional Office**

401 West Artesia Boulevard, Compton, California 90220  
U.S.A.

Tel. 213-537-8383

**HITACHI SALES CORPORATION OF HAWAII, INC.**

3219 Koapaka Street, Honolulu, Hawaii 96819, U.S.A.

Tel. 808-836-3621

**HITACHI (HSC) CANADA INC.**

3300 Trans-Canada Highway, Pointe Claire, Quebec,  
H9RU1B1, Canada

Tel. 514-697-9150

**HITACHI SALES EUROPA GmbH**

Postfach 801060 Rungedamm 2, 2050 Hamburg 80,  
West Germany

Tel. 040-734 11-0

**HITACHI SALES (U.K.) Ltd.**

Hitachi House, Station Road, Hayes, Middlesex UB3  
4DR, England

Tel. 01-848-8787

**HITACHI SALES SCANDINAVIA AB**

Rissneleden 8, Box 7138, 172-07 Sundbyberg, Sweden

Tel. 08-98 52 80

**HITACHI SALES NORWAY A/S**

Oerebekk 1620, Gressvik, P.O. Box 46, N-1601,

Fredrikstad, Norway

Tel. 032-28255

**SUOMEN HITACHI OY**

Takojankatsu 5, 15800 Lahti 80, Finland

Tel. Lahti 44 241

**HITACHI SALES A/S**

Kuldysen 13, DK-2630, Taastrup, Denmark

Tel. 02-999200

**HITACHI SALES A.G.**

Bahnhofstrasse, 19, 5600 Lenzburg, Switzerland

Tel. 064-513621

**HITACHI SALES WARENHANDELS GMBH**

A-1180/Wien, Kreuzgasse 27, Austria

Tel. 0222-439367

**HITACHI-FRANCE S.A.**

95-101 Rue Charles Michels,

93200 SAINT-DENIS, France

Tel. 821 6015

**HITACHI SALES ITALIANA, S.P.A.**

Via Cristoforo Colombo 49, Trezzano sul naviglio

(Milano), Italy

Tel. 02-44 59 031

**HITACHI SALES BELGIUM S.A.**

56, Chaussee de Namur B-1400 Nivelles, Belgium

Tel. (003267) 227181

**HITACHI SALES IBERICA, S.A.**

Gran Via Carlos Tercero, 101, 1-1, Barcelona-28,

Spain

Tel. 330-8652

**HITACHI SALES AUSTRALIA Pty Ltd.**

153 Keys Road, Moorabbin, Victoria 3189 Australia

Tel. 555-8722

**HITACHI Ltd. TOKYO JAPAN**

Head Office: THE HITACHI ATAGO BLDG.

No. 15-12, 2-Chome Nishi-Shinbashi

Minato-Ku, Tokyo 105, Japan

Tel. Tokyo (03) 502-2111