



HITACHI

D-550(U)

SERVICE MANUAL

No. 1010

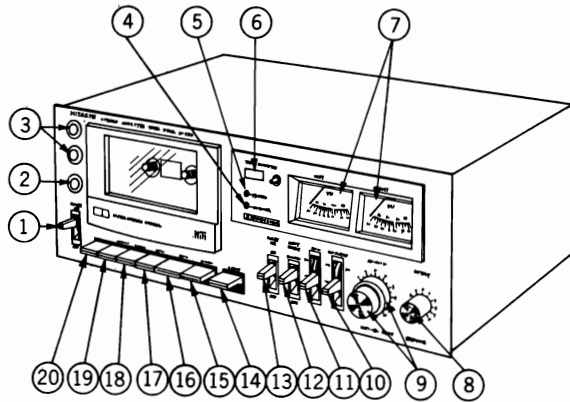

KEY TO ILLUSTRATION

- | | |
|-------------------------|-----------------------|
| ① POWER SWITCH | ⑪ BIAS SELECTOR |
| ② HEADPHONE JACK | ⑫ INPUT SELECT SWITCH |
| ③ MICROPHONE JACK | ⑬ DOLBY N. R. SWITCH |
| ④ DOLBY N. R. INDICATOR | ⑭ EJECT BUTTON |
| ⑤ RECORD INDICATOR | ⑮ PAUSE BUTTON |
| ⑥ TAPE COUNTER | ⑯ STOP BUTTON |
| ⑦ VU METERS | ⑰ FAST FORWARD BUTTON |
| ⑧ OUTPUT CONTROLS | ⑱ PLAYBACK BUTTON |
| ⑨ RECORD LEVEL CONTROLS | ⑲ REWIND SWITCH |
| ⑩ EQUALIZER SELECTOR | ⑳ RECORD BUTTON |

SPECIFICATIONS

Semi-conductors :	IC's : 6 Transistors : 9 Diodes : 19 LED's : 2 Zener diode : 1	Input sensitivity and Impedance :	Microphone : 0.25mV (Suitable microphone impedance 300 ohms to 5 kohms) Line in : 60mV, 47 kohms or more Record/playback (DIN) : 0.25mV, 2 kohms
Track System :	4 track 2 channel	Output level :	0.5V or more
Tape :	Cassette tape (C-30, 60, 90)	Output Load Impedance :	Line : 50 kohms or more Record/playback (DIN) : 50 kohms or more Headphone : 8 ohms to 2 kohms (Suitable)
Tape Speed :	4.75cm/s	Distortion :	1.8% (1 kHz 0 VU)
Recording System and Bias Frequency :	AC bias, 105 kHz	Crosstalk :	60 dB (at 1 kHz) or more
Erasing System :	AC erase	Fast Forwarding or Rewinding Time :	100 seconds (Using C-60)
Erase Ratio :	65 dB (at 1 kHz) or more	Power Supply :	AC120V, 60 Hz
Frequency Response :	UD/Normal : 30 Hz to 14 kHz 30 Hz to 12.5 kHz ± 3 dB FeCr : 30 Hz to 15 kHz 30 Hz to 14 kHz ± 3 dB CrO ₂ : 30 Hz to 15 kHz 30 Hz to 14 kHz ± 3 dB	Power Consumption :	11W
S/N (Signal to Noise Ratio)	Dolby ON : 58 dB Dolby OFF : 53 dB	Dimensions :	14.3(H) \times 39.0(W) \times 25.4(D)cm
Wow and Flutter :	0.08% (WRMS)	Weight :	5.6 kg
		Motor :	DC servo motor
		Heads :	Record/playback head \times 1 Erase head \times 1

STEREO CASSETTE TAPE DECK

Nov. 1977

SAFETY PRECAUTION

The following precautions should be observed when servicing.

1. Since many parts in the unit have special safety-related characteristics, always use genuine Hitachi's replacement parts. Especially critical parts in the power circuit block should not be replaced with other makers. Critical parts are marked with ★ in the schematic diagram, and circuit board diagram.
2. Before returning a repaired unit to the customer, the service technician must thoroughly test the unit to ascertain that it is completely safe to operate without danger of electrical shock.

EXPLANATION OF NEW DECK CHASSIS

1. Power-assisted control mechanism

1) When the playback button is pressed, the playback slider shown in Fig. 1 slides in the direction of the arrow ①. After this, the gear-drive arm and the playback lock plate slide in the directions of arrows ② and ③ and lock in the positions shown in color, by means of the playback lock plate.

At the same time, the motor switch turns "ON" by means of the movement of the lock plate, the motor starts and the flywheel rotates in the direction of arrow ④ (Fig. 2).

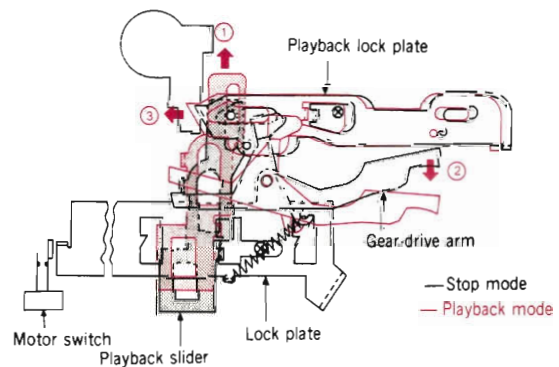

Fig. 1

2) As the gear-drive arm slides to the position shown in color by Item 1) as shown in Fig. 2, the shaft A, which is attached to the playback gear moves along the inclined surface of the gear-drive arm to make the playback gear rotate in the direction of arrow ⑤ so that 1 or 2 teeth of the gear engage the gear of the flywheel.

The engaged gear wheel which has been engaged rotates because of the flywheel, and continues to rotate in the direction of arrow ⑤.

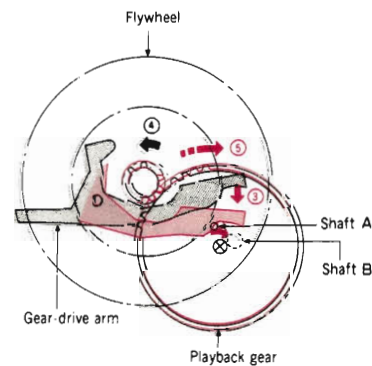

Fig. 2

3) Fig. 3 shows the connection of the shaft of the playback plate and playback arm which operate the head plate and pressure roller.

Following the rotation of the playback gear, the shaft B, which is attached to the playback gear, rotates in the direction of arrow ⑥ shown in Fig. 4, whereby the playback arm slides in the directions of arrows ⑦ and ⑧, and the playback plate, which is connected via the shaft, slides in the direction of arrow ⑨ shown in Fig. 3.

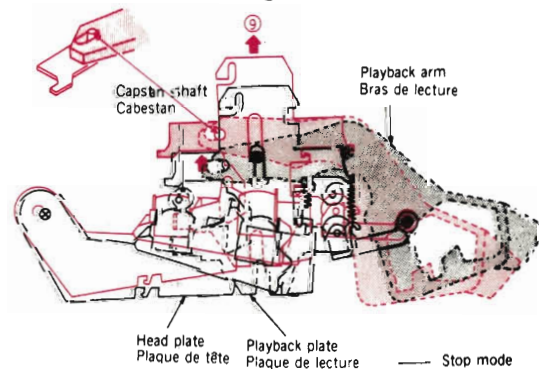

Fig. 3

4) When the playback arm slides to the position shown in color in the Fig. 4., the shaft of the playback plate is locked by means of the playback lock plate and then there is playback.

Note : Under the stop condition (the condition when the head is away from the cassette part such as in fast forward, rewind, pause, stop, etc.) the shaft B, which is attached to the playback gear, moves to the position (shown by the broken line) as shown in Fig. 5.

This operates in conjunction with the compression spring, which is inserted under the playback gear, to prevent rotation of the playback gear so that the playback gear does not engage with the gear of the flywheel because of shock or vibration.

Incidentally, under the playback mode, the shaft B moves to the position as shown in Fig. 5 (it is positioned at the convex portion after 1 rotation) so that the playback gear does not rotate anymore and the playback plate does not repeat its operation.

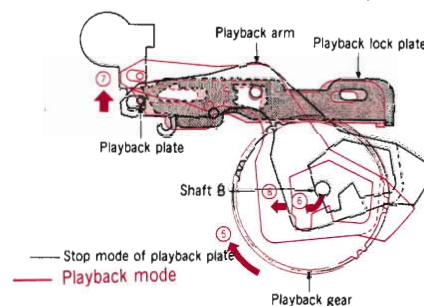

Fig. 4

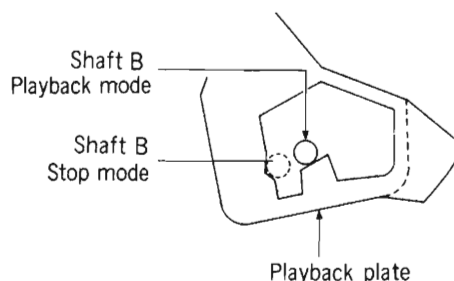

Fig. 5

2. Stop mechanism (Fig. 6)

What is shown in black is the playback mode : when the stop button is depressed in this mode, the lock plate slides in the direction of arrow ② and the lock of the playback slider is released.

The playback slider returns to the position shown in color and the motor turns OFF. At the same time, the stop arm rotates to the position shown in color in the direction of arrow ③ by means of the lock plate which slides across and makes the playback lock plate slide in the direction of arrow ④, to release the lock of the shaft of the playback plate.

The playback plate slides in the direction of arrow ⑤ due to the release of the lock : and then the head and pressure roller are released from the cassette-part, and the stop mode is obtained.

As for the stop operation when it is set in the recording, fast forward or rewind modes : when the stop button is depressed, the lock plate slides and the lock of each slider is released, and thus the stop operation is carried out.

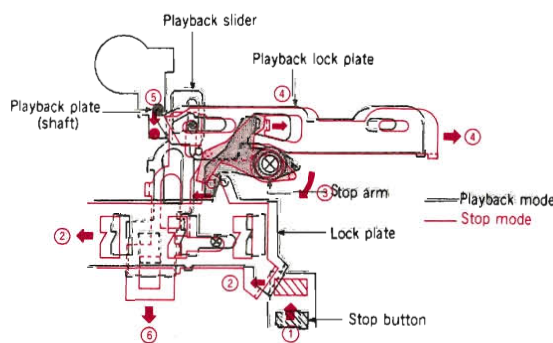

Fig. 6

3. Pause mechanism (Fig. 7)

What is shown in black is the playback mode : when the pause button is depressed in this mode, the pause slider slides in the direction of arrow ① .

The playback lock plate slides in the direction of arrow ② due to this and it releases the lock of the shaft of the playback plate.

The playback plate slides in the direction of arrow ③ due to this release of the lock, and the head and pressure roller are released from the cassette-part. At the same time, the gear-drive arm slides to the position shown in color in the direction of arrow ④ , and stops the operation the powered-assisted control mechanism.

When the pause is released, the same mode as when the playback button is depressed is obtained, the gear-drive arm moves near to the playback gear, and the playback mode is obtained within 0.5 sec by means of the power-assisted control mechanism.

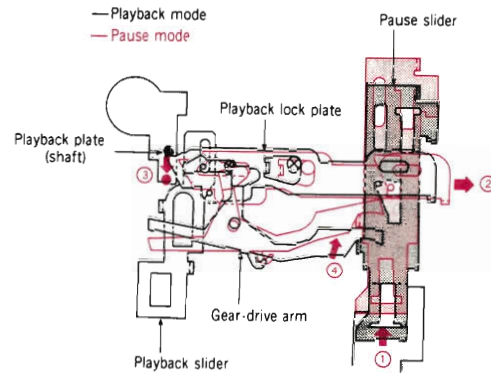

Fig. 7

4. Take-up mechanism (Fig. 8)

What is shown in black is the stop mode : when the playback button is depressed, the power-assisted control mechanism operates : the playback plate slides in the direction of arrow ① as shown in color, whereby the take-up arm rotates in the direction of arrow ② .

Since the section, shown by the broken lines, of the take-up arm is concave, the tip of the take-up gear shaft enters into this concave portion, and the take-up gear rises in the direction of arrow ③ by means of the spring and engages with the take-up side reel.

Since the take-up gear is rotated by the take-up belt, the rotation in the direction of arrow ④ is transmitted to the take-up reel and the tape is wound on it.

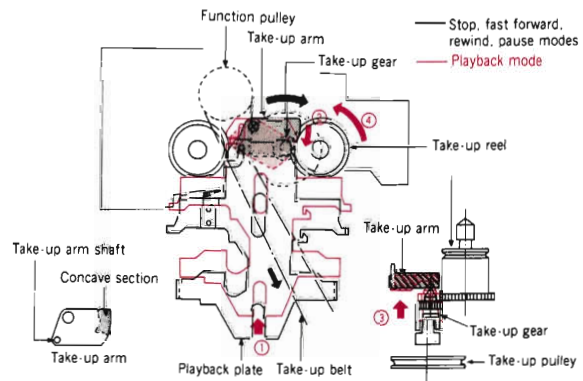

Fig. 8

5. Fast forward/rewind mechanism

Fig. 9 shows the fast forward/rewind mechanism, which is built into the gear assembly ; the black shows the stop mode and the color shows the rewind mode.

The function gear (Rewind) and the function gear (Fast forward) rotate in the directions of the arrows respectively when the motor switch is turned ON.

Fig. 10 shows the function arm : the section shown in broken lines is concave and other sections are convex. By means of these concave and convex sections, the height of the function gear which make contact with this surface is changed, and the engagement of each reel and function gear can be managed.

Under the stop condition, the function gear, reel and the function arm are under the mode shown in black in Fig. 11 ; when the rewind button is depressed, the rewind slider slides in the direction of arrow ① as shown in Fig. 12, and the function arm rotates in the direction of arrow ② with one end of the fast forward slider as the fulcrum. When the function arm is inclined, the surface where the function arm and the tip of the shaft of the function gear (Rewind) contact becomes convex as shown in color in Fig. 11, and the function gear (Rewind) rises and engages with the supply reel, and it is then in the rewind mode.

(Fast forward has the same operational principle as that of rewind).

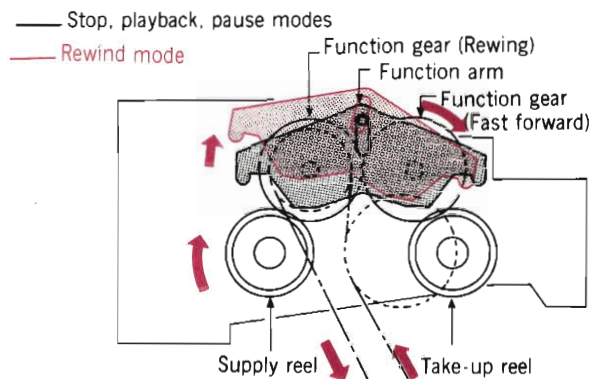

Fig. 9

Function arm

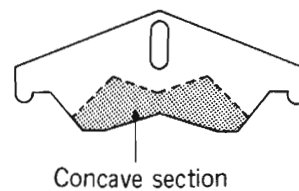

Fig. 10

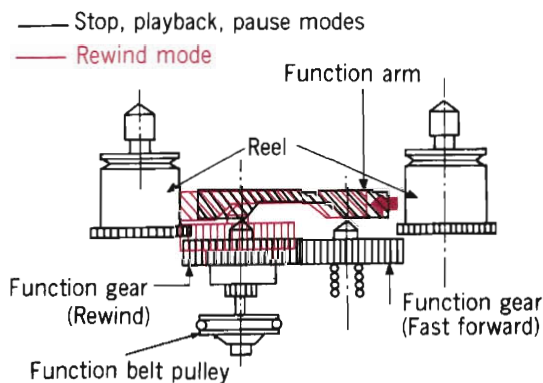

Fig. 11

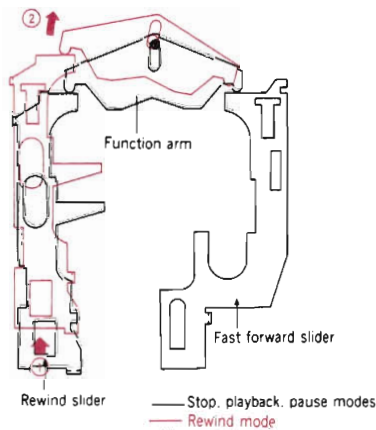

Fig. 12

6. Auto-stop mechanism

1) Fig. 13 shows the tape-end detector of the auto-stop mechanism.

Under the recording, playback, fast forward and rewind modes, the take-up belt, pulley, gears and cam gears rotate in the directions of the arrows respectively, and when the tape is not completely taken up, the take-up reel rotates in the direction so that it will take-up the tape.

The floating cam is provided on the same axis as the take-up reel shaft, and it lightly touches the reel by means of the spring. Utilizing the face that when the reel rotates, the floating cam faces in the direction of rotation, the floating movement of the cam gear and the floating arm, which has its fulcrum at (A) as shown in Fig. 13, is applied to this floating cam, to detect the end of the tape.

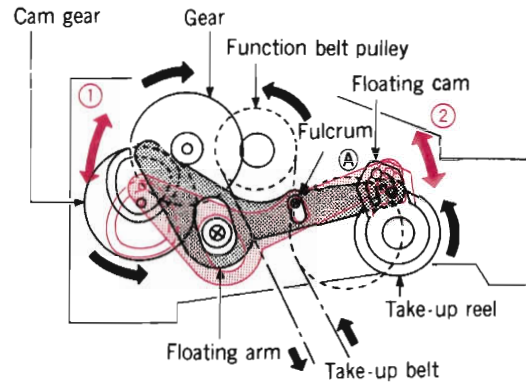

Fig. 13

Method of detecting the tape-end

Shafts, which enter into the cam of the cam gear and the shaft which in turn enters into the slide groove of the floating cam are provided at both ends of the floating cam ; the floating movement is carried out in the direction of arrow ① with its fulcrum at (A) as shown in Fig. 13, by means of the rotation of the cam gear.

The shaft of the floating arm, which enters into the groove on the floating cam, operates to slide and relieve the floating movement which is caused by the cam gear by means of this groove.

When the cam of the cam gear rotates to the position shown in color in Fig. 13, the shaft of the floating arm on the floating cam side goes into the mode shown in (A) of Fig. 14.

Next, when the cam gear rotates to the position shown in black, the position of the shaft on the floating cam side goes into the mode shown in (B) of Fig. 14 during playback or fast forward, and (C) during rewind. These slide grooves are determined by the direction of rotation of the reel.

Incidentally, during pause, since the reel is being stopped, the auto-stop mechanism starts to operate. To prevent this, the floating cam is pressed in the direction of arrow ③ (take-up direction) by the auto-stop control spring as shown in (D) of Fig. 14 during pause and stop.

(The AS (auto-stop) control spring is operated by the sliding of the brake plate ; it is so designed that the AS control spring is released from one end of the floating cam and the floating cam faces in the direction of rotation of the reel, except during the pause and stop modes.) When the tape is finished and the reel stops, the floating cam side shaft of the floating arm slides between (A) and (E) in Fig. 14. This width in which it slides is smaller than that between (A) and (B) or (A) and (C) ; when the floating arm slides up to point (E) in Fig. 14, the floating arm slides in the direction of arrow ④ in Fig. 15 with the floating cam as the fulcrum. The tape-end is detected by means of this sliding of the floating cam.

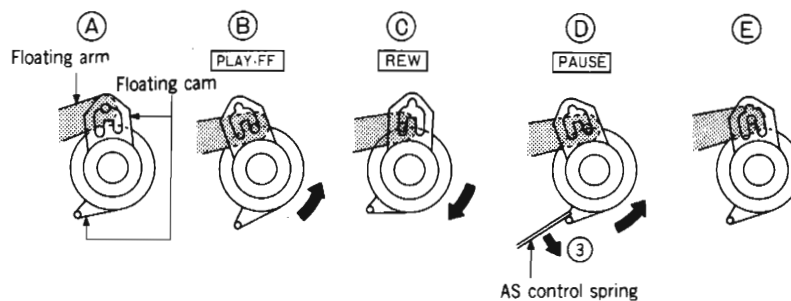

Fig. 14

- 2) When the tape-end is detected and the floating arm slides, the AS arm as shown in Fig. 15 slides in the direction of arrow ⑤ with its fulcrum at ④ .

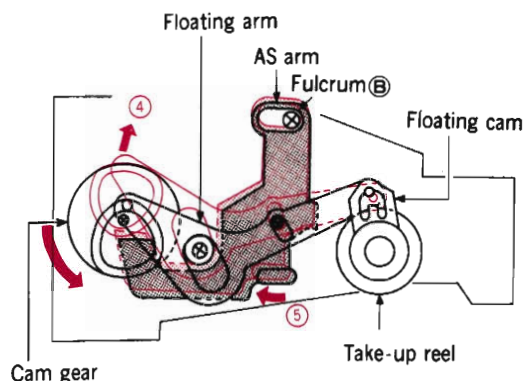

Fig. 15

- 3) When the AS arm slides into the position shown in black in Fig. 16, it engages with the AS cam under the cam gear and slides in the direction of arrow ⑥ .
- 4) When the AS arm slides into the position shown in color, the AS lever rotates in the direction of arrow ⑦ and makes the lock plate move in the direction of arrow ⑧ . This sliding of the lock plate causes the same conditions as when the stop button is depressed, and each slider goes into the stop mode.

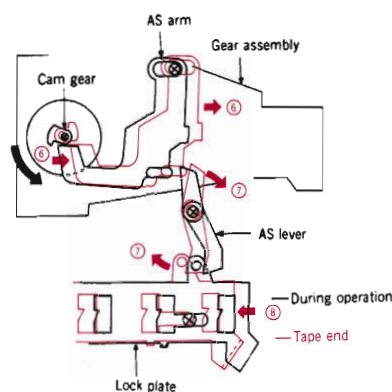

Fig. 16

7. Eject prevention mechanism (Fig. 17)

When the playback button or other operational buttons are depressed, the eject prevention slider slides in the direction of arrow ② and it turns the motor switch *ON*. eject can be done only under the stop mode, but if the eject button is depressed and the cassette holder is open, since the eject slider is in the convex portion as shown in ④ of the eject prevention slider, the eject prevention slider does not operate by pressing the playback or other operational buttons, and the playback, recording, fast forward and rewind operations are prevented from occurring. Under the modes other than the stop mode, the eject slider touches the point ④ of the eject prevention slider and prevents the eject operation from occurring.

When the playback button is depressed, the eject prevention slider slides in the direction of arrow ② and at the same time, the playback arm slides in the direction of arrow ③ .

(The playback arm slides into the playback position as shown in ⑤ when the playback gear rotates about 1/3 of a turn).

When the stop button is depressed just before the playback plate shaft is locked, the eject prevention slider tries to slide in the reverse direction of arrow ② but the playback arm prevents this sliding and the motor switch does not turn OFF. The motor and the gear rotate until the stop mode (when the playback arm goes into the position shown in black) is obtained. In this way, the power-assisted control mechanism operates,

and the stopping of the playback gear halfway or the operation of the eject mechanism during this time, when the stop button is depressed just before the head or pressure roller is locked, is prevented.

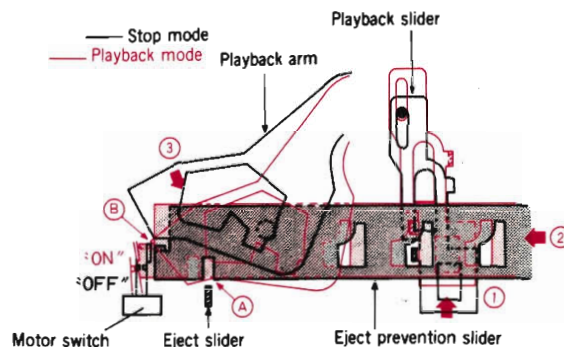

Fig. 17

DISASSEMBLY

Removing process

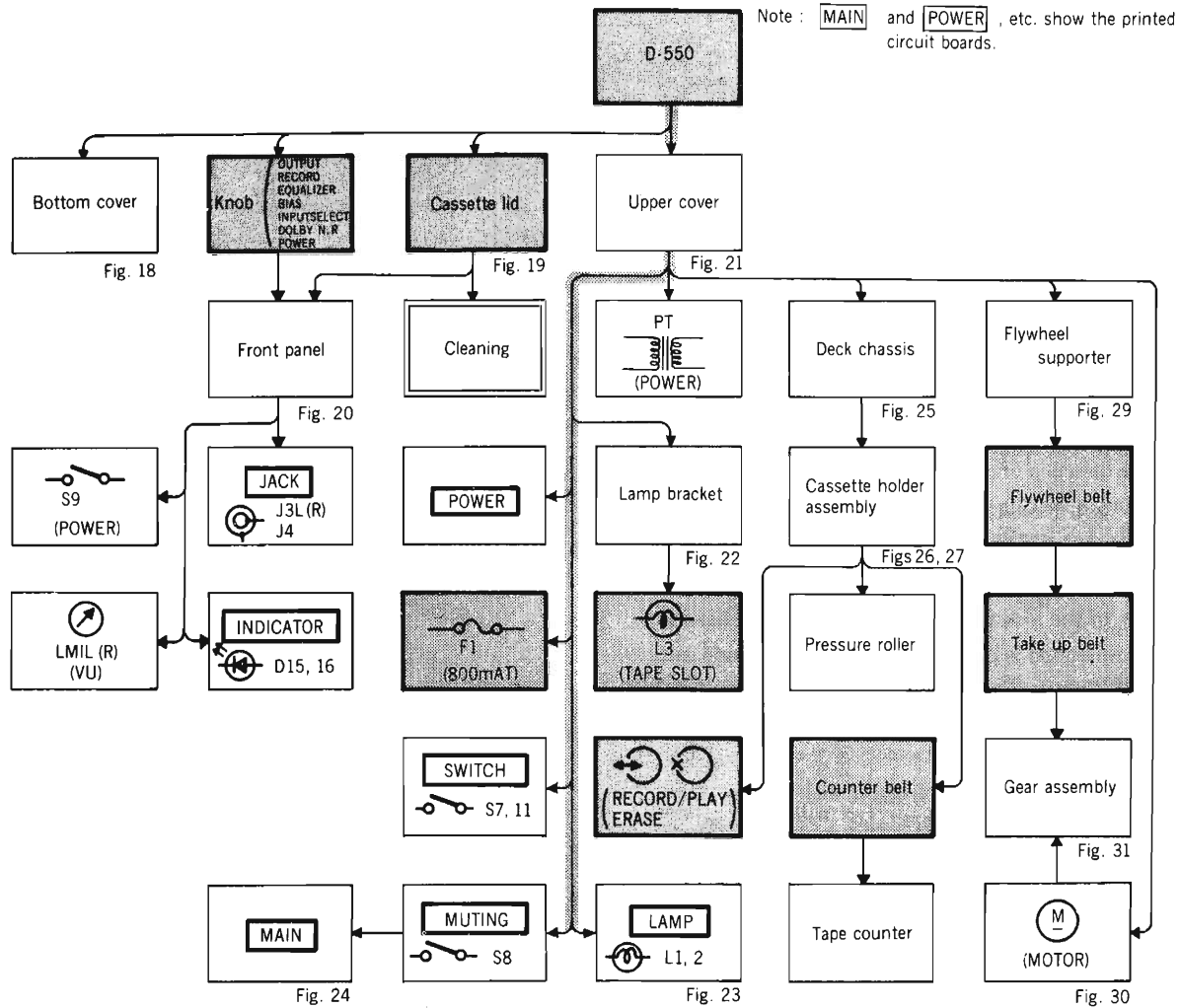

Diagram showing dismantling

1. Bottom cover

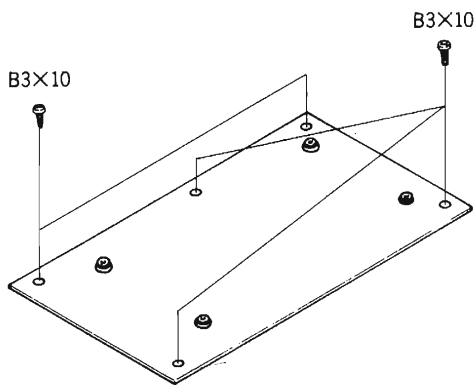

Fig. 18

2. Cassette lid

- 1) Depress the eject button and the cassette lid will open.
- 2) Lift up the cassette lid in the direction of arrow.

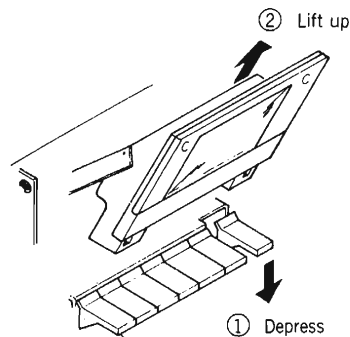

Fig. 19

3. Upper cover

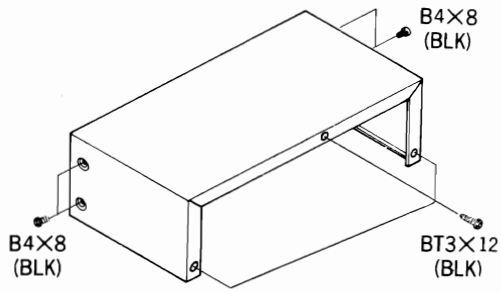

Fig. 20

4. Front panel

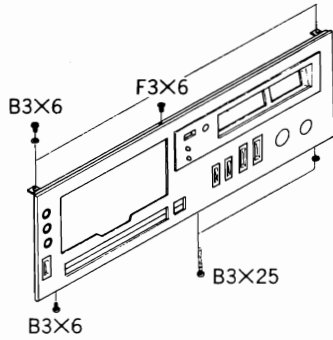

Fig. 21

5. Lamp bracket

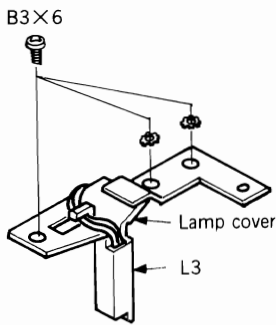

Fig. 22

6. LAMP

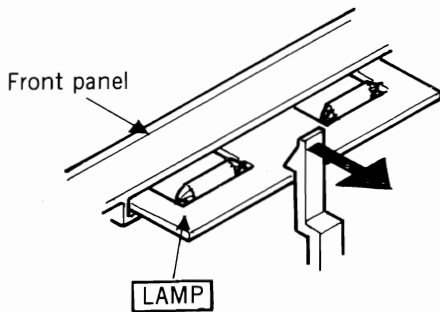

Fig. 23

7. MAIN

Checking or replacement of the components can be done by removing the bottom cover. (Refer to Item 1, *Bottom cover*). When removing the printed circuit board, however, undertake the following procedure.

- ① Remove the fixing screws.
- ② Move the printed circuit board approx. 1cm toward the front panel.
- ③ Remove the printed circuit board while lifting it at its rear.

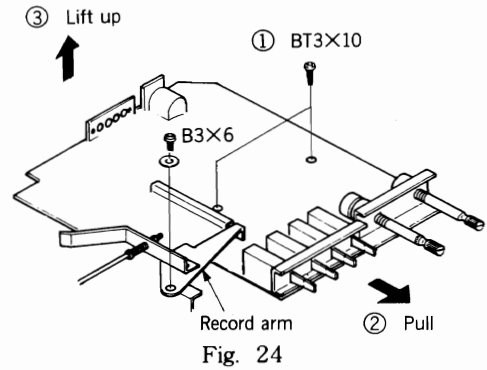

Fig. 24

8. Deck chassis

Since the cassette deck chassis and the MAIN are connected with the connector and pin-connector, remove the deck chassis after removing those connectors.

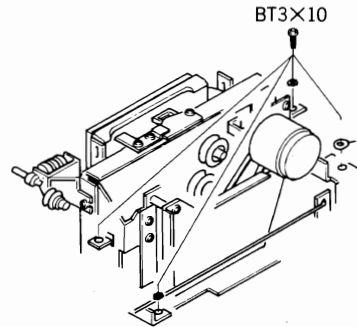

Fig. 25

9. Cassette holder assembly

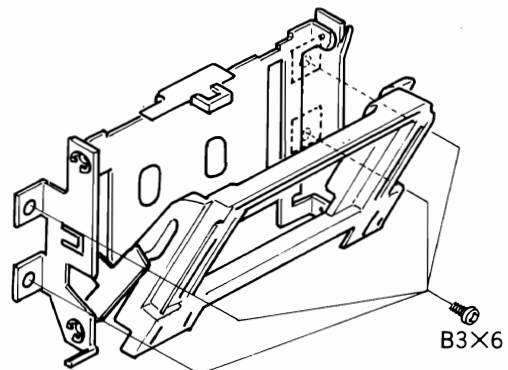

Fig. 26

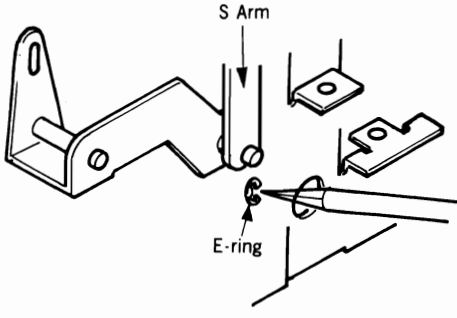

Fig. 27

Installation of the cassette holder assembly

Before installing the cassette holder assembly, first check that the eject slider, eject arm and the counter belt are as shown in the Fig. 28.

Note : When the eject slider and eject arm are not as shown in the figure, the eject operation may not be smooth or the tape may touch the recording prevention arm, making the cassette holder not fit it properly.

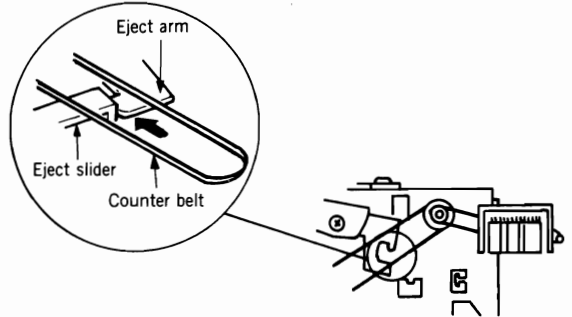

Fig. 28

10. Flywheel supporter

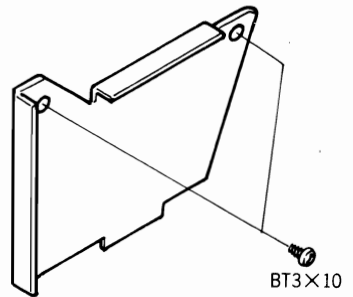

Fig. 29

11. Motor

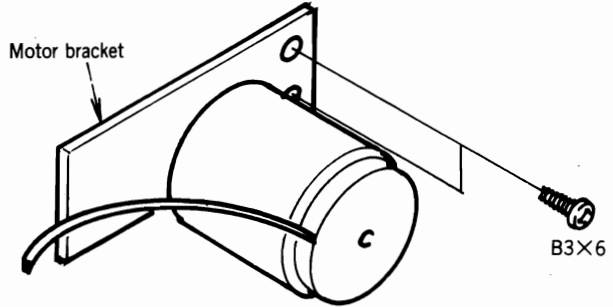

Fig. 30

12. Gear assembly

The gear assembly is composed of the gears, cams, clutches, and reel, of the full auto-stop mechanism, fast forward/rewind mechanism and take-up mechanism. It can be removed by removing the fixing screws (Fig. 31).

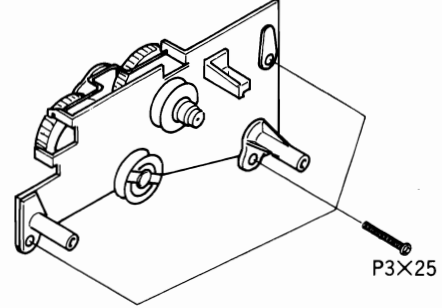

Fig. 31

Installation of the gear assembly

Install the gear assembly after setting the chassis body to the fast forward mode. Incidentally, check the gear assembly so that it is in the fast forward mode.

- ① Turn the function arm (shown in Fig. 32) in the direction of the arrow until it touches the point shown by arrow ⑥ on the take up arm. The reel, the function gears and function arm go into the mode shown in Fig. 33.

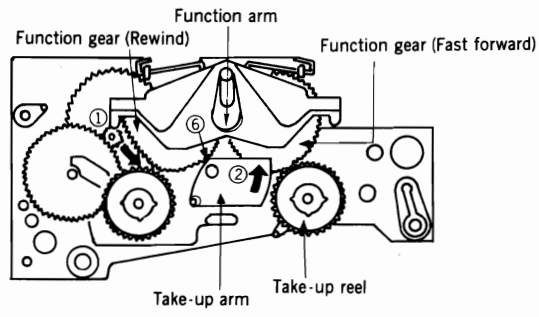

Fig. 32

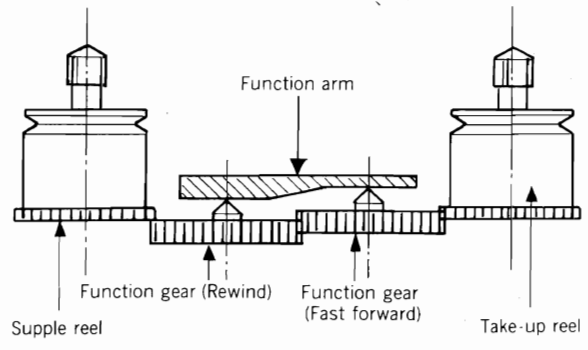

Fig. 33

- ② Turn the take-up arm (shown in Fig. 32) in the direction of the arrow until the take-up gear and reel under-neath separate from each other shown in the Fig. 34.

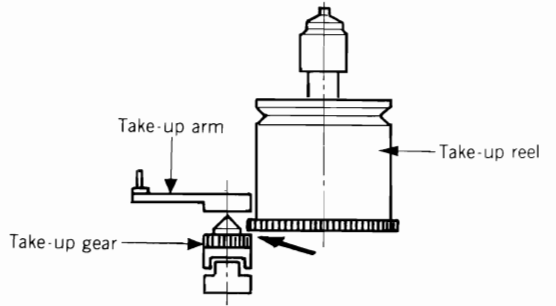

Fig. 34

- ③ Take out the take-up arm operating shaft (shown in Fig. 34) from the hole on the playback plate as shown in Fig. 35, and fix the gear assembly using screws.

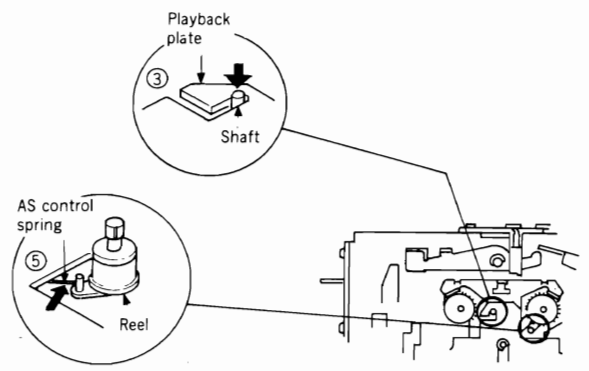

Fig. 35

- ④ Fix the counter belt onto the reel (take-up side).
- ⑤ Depress the stop button to get it into the stop mode, and check that the auto-stop control spring (shown in Fig. 35) presses the floating cam under the reel in the direction of the take-up side as shown in the figure.

Clean the record/playback head, erase head, capstan shaft and pressure roller.

Tape speed (motor speed) adjustment

1. Setting—Playback mode

Symbol No.	Switches and controls	Position
S2	Equalizer select switch	NOR
S3	Bias select switch	MID
S4	Input select switch	LINE
S5	Dolby N.R switch	OFF
RV1L, R	Record level controls	Maximum
RV2L, R	Output level controls	Maximum

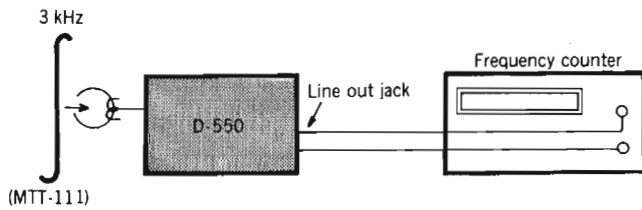

Fig. 36

2.

Adjust	Reading	Remarks
Semi-variable resistor on the motor	3000 Hz \pm 30 Hz	Carry out measurement at the middle of the tape 10–20 sec after warming up.

Head azimuth adjustment

1. Setting—Playback mode

Symbol No.	Switches and controls	Position
S2	Equalizer select switch	NOR
S3	Bias select switch	MID
S4	Input select switch	LINE
S5	Dolby N.R switch	OFF
RV1L, R	Record level controls	Maximum
RV2L, R	Output level controls	Maximum

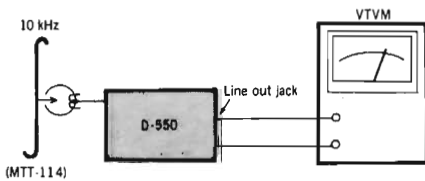

Fig. 37

2.

Adjust	Reading	Remarks
Azimuth adjustment screw	Maximum	When the peaks of both channel are different, adjust it to between the peaks.

Playback level (gain) and VU meter adjustment

1. Setting—Playback mode

Symbol No.	Switches and controls	Position
S2	Equalizer select switch	NOR
S3	Bias select switch	MID
S4	Input select switch	LINE
S5	Dolby N.R switch	OFF
RV1L, R	Record level controls	Maximum
RV2L, R	Output level controls	Maximum

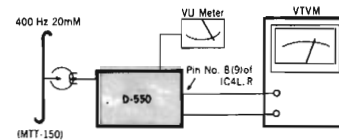

Fig. 38

2.

Adjust	Reading	Remarks
RT1L, R	0.775V	
RT3L, R		Pointer of the VU meter indicate the Dolby mark.

19 kHz trap adjustment

1. Setting—Recording mode

Symbol No.	Switches and controls	Position
S2	Equalizer select switch	NOR
S3	Bias select switch	MID
S4	Input select switch	LINE
S5	Dolby N.R switch	OFF
RV1L, R	Record level controls	Maximum
RV2L, R	Output level controls	Maximum

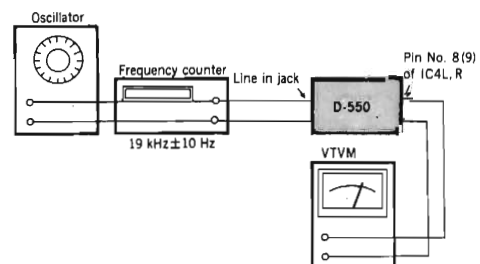

Fig. 39

2.

Adjust	Reading	Remarks
L2L, R	Minimum	

Bias trap adjustment

1. Setting—Recording mode

Symbol No.	Switches and controls	Position
S2	Equalizer select switch	NOR
S3	Bias select switch	MID
S4	Input select switch	LINE
S5	Dolby N.R switch	OFF
RV1L, R	Record level controls	Maximum
RV2L, R	Output level controls	Maximum

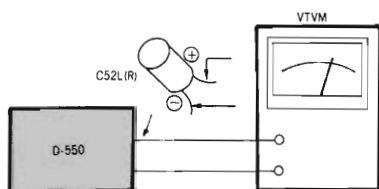

Fig. 40

2.

Adjust	Reading	Remarks
L4L, R	Within 1 dB of min. value	

Bias current adjustment

1. Setting—Recording mode

Symbol No.	Switches and controls	Position
S2	Equalizer select switch	NOR
S3	Bias select switch	MID
S4	Input select switch	LINE
S5	Dolby N.R switch	OFF
RV1L, R	Record level controls	Maximum
RV2L, R	Output level controls	Maximum

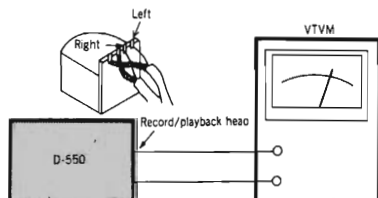

Fig. 41

2.

Adjust	Reading	Remarks
RT4L, R	11V	

Recording/playback output level adjustment

1. Setting—Recording/playback mode

Symbol No.	Switches and controls	Position
S2	Equalizer select switch	NOR
S3	Bias select switch	MID
S4	Input select switch	LINE
S5	Dolby N.R switch	OFF
RV1L, R	Record level controls	Maximum
RV2L, R	Output level controls	Maximum

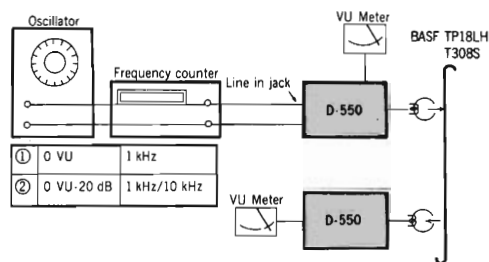

Fig. 42

2.

Adjust	Reading	Remarks
① RT2L, R	OVU	Remarks
② RT1L, R		Check the output levels of two signals (1-kHz/10 kHz). The difference between two signals should be also within ± 1.5 dB. If the difference is not within ± 1.5 dB, re adjust RT4L, R.

Dolby N. R adjustment

1. Setting—Recording mode

Symbol No.	Switches and controls	Position
S2	Equalizer select switch	NOR
S3	Bias select switch	MID
S4	Input select switch	LINE
S5	Dolby N. R switch	OFF \rightarrow ON
RV4L, R	Record level control	Maximum
RV2L, R	Output level control	Maximum

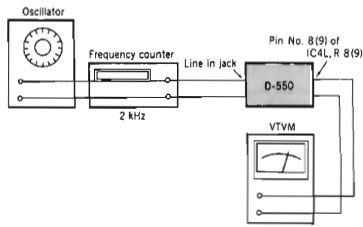

Fig. 43

2.

Adjust	Reading	Remarks
		Adjust output level of an oscillator so that level of the IC4L, R pin No. 8(9) is -20 dB.
RT5	-15.7 dB	Dolby : On

Adjustment and semi-conductor parts location

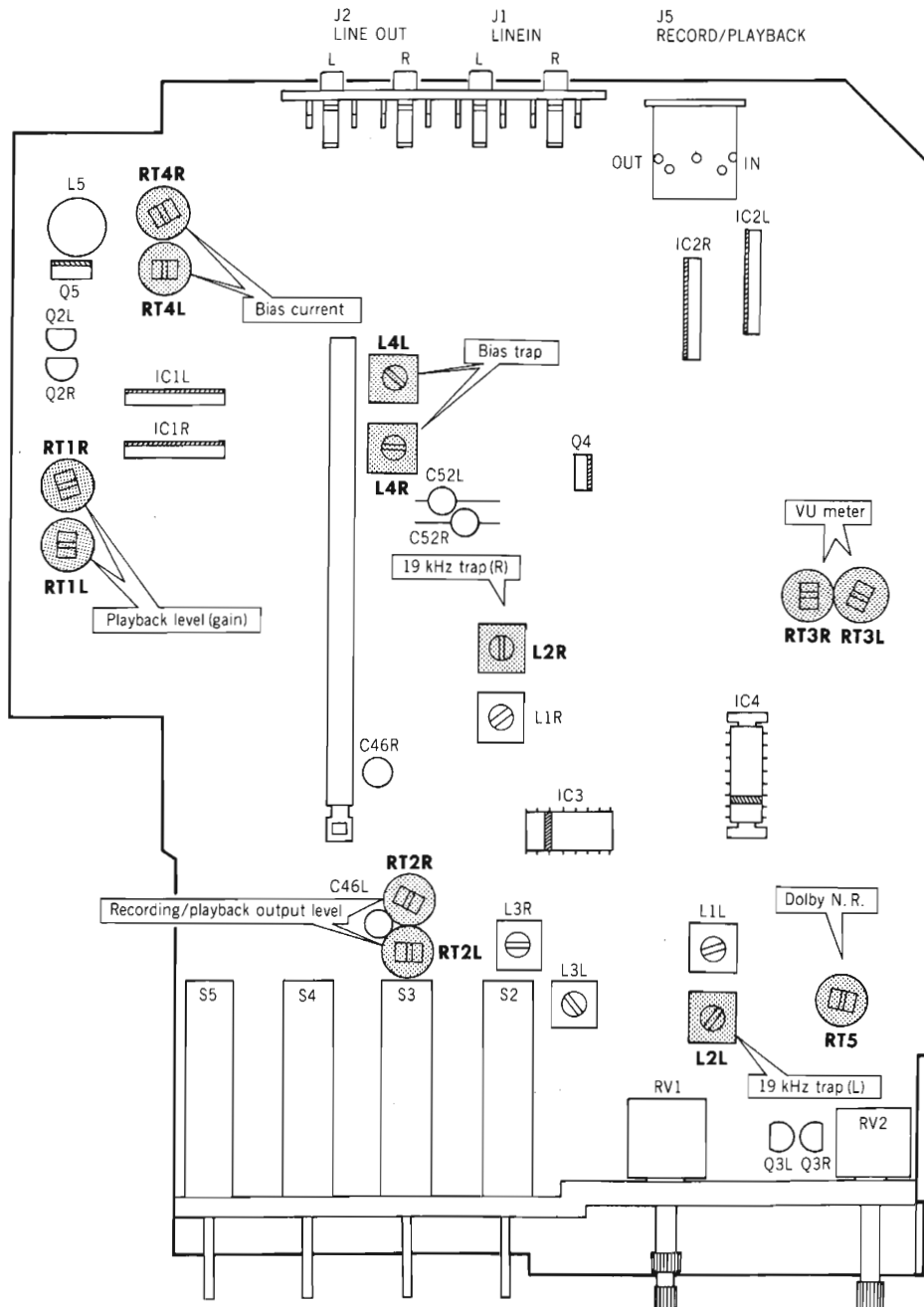

Fig. 44

INSPECTION OF MECHANISM

Pressure roller pressure

Measure the pressure at the moment when the pressure roller is away from the capstan shaft with a tension gauge, in the playback mode. It should be within 300 to 450g.

* If the pressure is less than 300g, replace the spring with a new one.

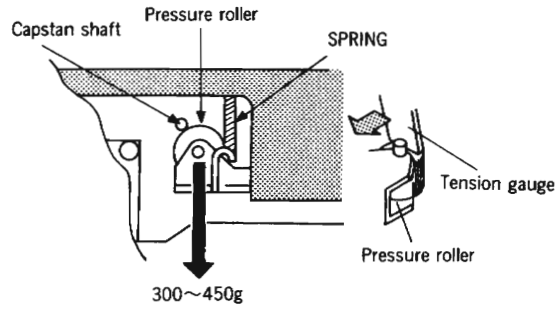

Fig. 45

Torque

Take up	37 to 70g-cm
Fast forward	75 to 120g-cm
Rewind	75 to 120g-cm

Back tension

Take up reel	Less than 4g-cm Note : Measure it when the counter belt is attached.
Supply reel	1 to 2g-cm Note : Measure it, in the playback or fast forward mode.

Braking force

Take up reel	Less than 5g-cm	Supply reel	Take up reel
Supply reel	Less than 5g-cm		

Switching time

Auto stop	Within 10 seconds Note : Time required for auto-stopping after the tape has stopped to run.
Playback start	Within 0.5 sec Note : Time required to start playing back after the PLAYBACK button is depressed and locked.
Pause start	Within 0.5 sec Note : Time required to start playing back after the lock of the PAUSE button has been released.
Eject	From 0.5 to 3.0 sec Note : Time required for the cassette lid to open completely after the EJECT button is depressed.

LUBRICATION

Lubricate one or two drops of machine oil to rotating point or lubricate grease to sliding point. Lubricate the respective parts listed below once every 1000 hours or once a year under normal conditions of use. Avoid oiling then excessively, or rotation may become irregular because of oil splashes.

Lubrication	
Motor shaft bearing	Oil
Capstan shaft bearing	
Pressure roller bearing	

LEVEL DIAGRAM

Playback

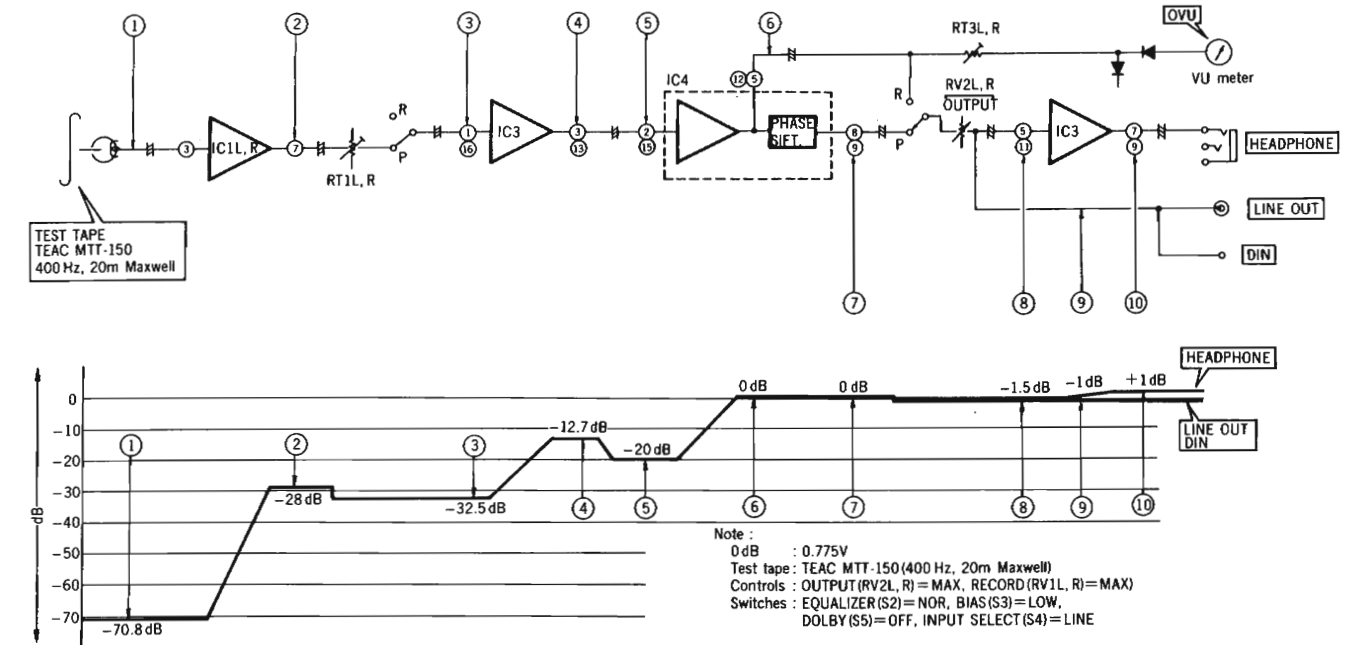

Recording

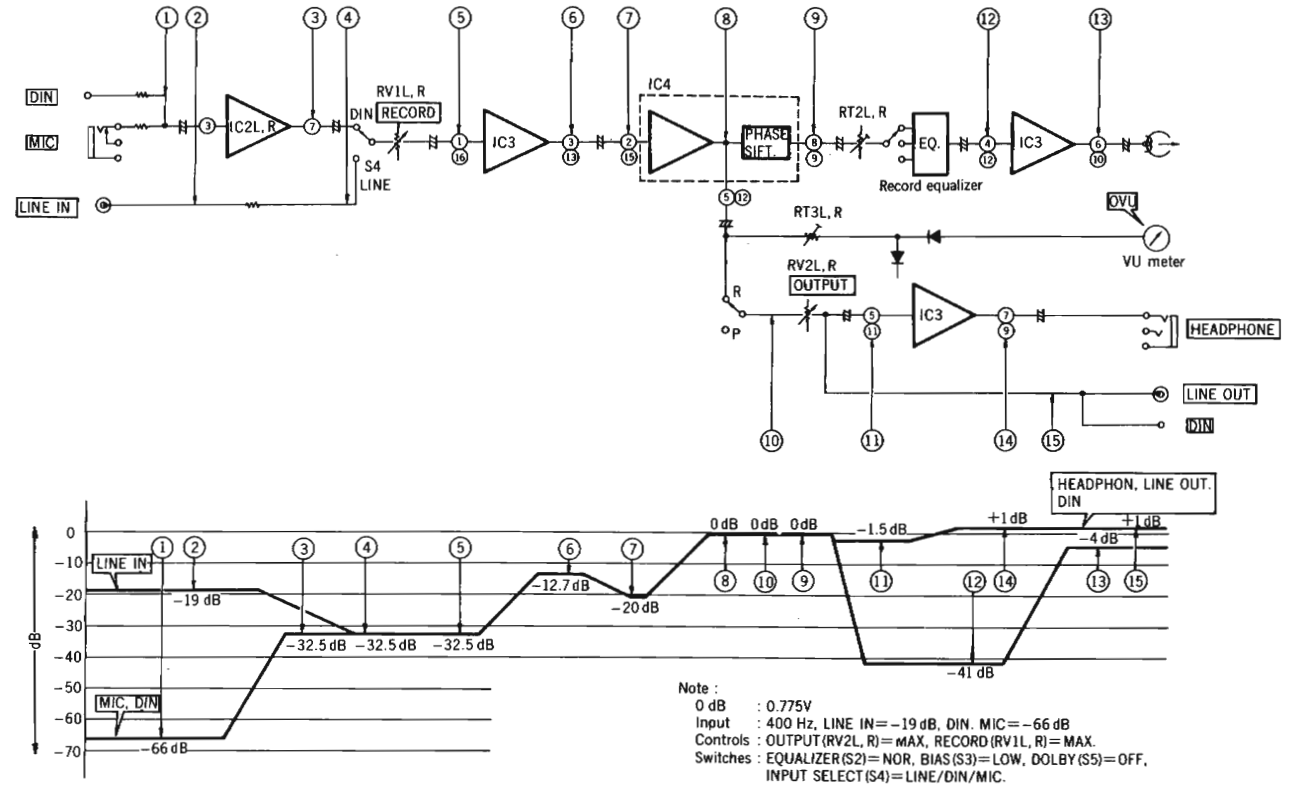

SCHEMATIC DIAGRAM

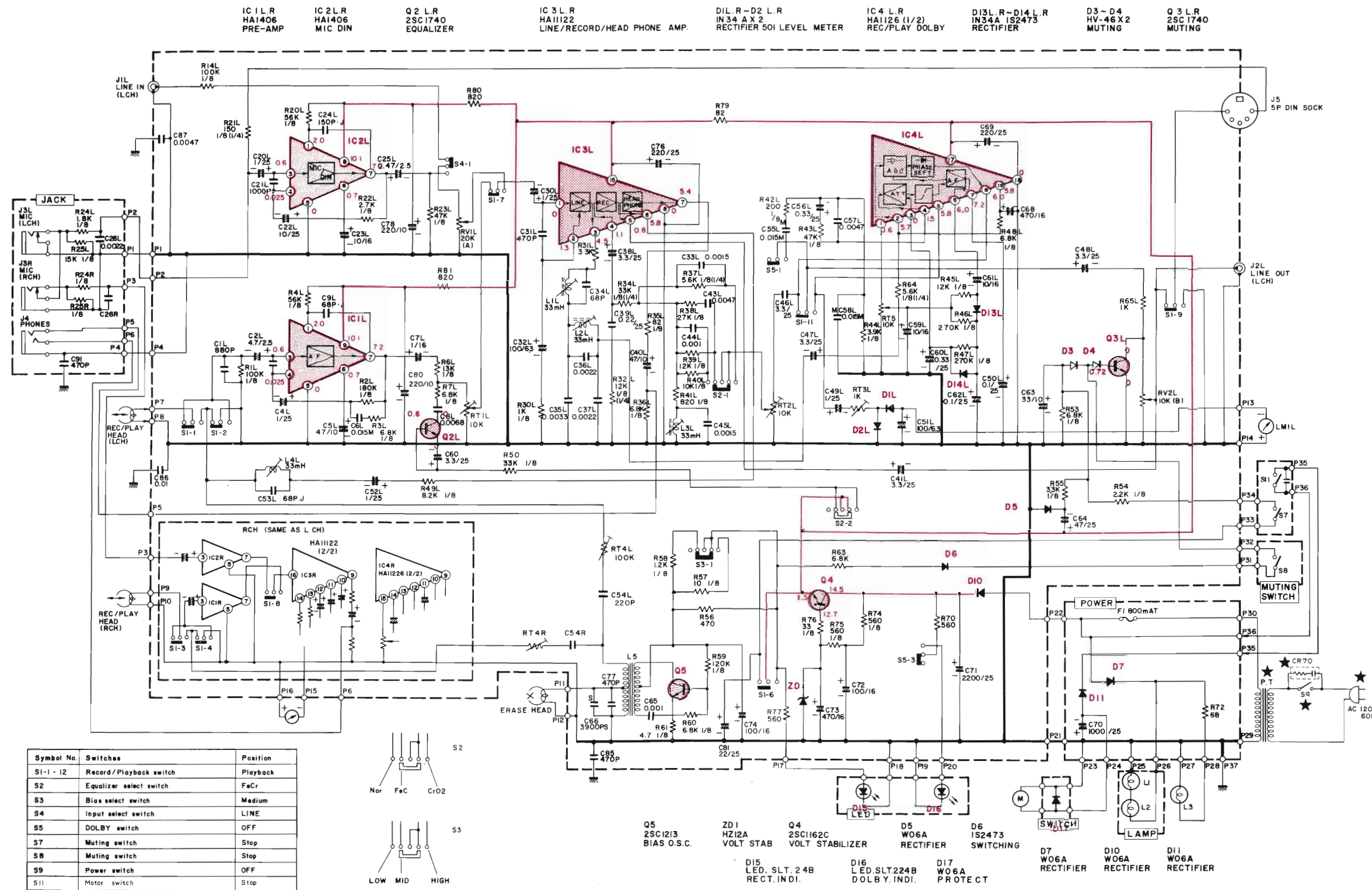

IC1 L.R HA1406 PRE-AMP IC2 L.R HA1406 MIC DIN Q2 L.R 2SC1740 EQUALIZER IC3 L.R HA1122 LINE/RECORD/HEAD PHONE AMP. DIL R-D2 L.R IN34 A X 2 RECTIFIER 50I LEVEL METER IC4 L.R HA1126 (1/2) REC/PLAY DOLBY D13 L.R-D14 L.R IN34A IS2473 RECTIFIER D3-D4 HV-46 X 2 MUTING Q3 L.R 2SC1740 MUTING

Symbol No.	Switches	Position
SI-1 - 12	Record/Playback switch	Playback
S2	Equalizer select switch	FaCr
S3	Bias select switch	Medium
S4	Input select switch	LINE
S5	DOLBY switch	OFF
S7	Muting switch	Stop
S8	Muting switch	Stop
S9	Power switch	OFF
SI1	Motor switch	Stop

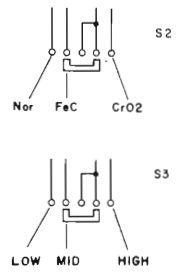

Q5 2SC1213 BIAS O.S.C. ZD1 HZ12A VOLT STAB Q4 2SC1162C VOLT STABILIZER D5 W06A RECTIFIER D6 IS2473 SWITCHING D7 W06A RECTIFIER D10 W06A RECTIFIER D11 W06A RECTIFIER

D15 LED, S.L.T. 24B RECT. INDI. D16 LED, S.L.T.224B DOLBY. INDI. D17 W06A PROTECT

Note

1. Voltage measured at base of chassis with minimum volume control and no signal.
2. Nomenclature of Resistors and Capacitors.

Circuit No.	
Value	No indicated Ω(Ohm) M : 1000 kΩ
Tolerance	No indicated ±5% K : ±10% M : ±20%
Wattage	No indicated ¼W
Sort	No indicated Carbon film RC : Composition RW : Wire wound RS : Oxide metal film RN : Fixed metal film

Circuit No.	
Value	No indicated μF P : PF
Tolerance	No indicated ±10% J : ±5% M : ±20% Z : +80% -20% D : ±0.5pF C : ±0.25pF
Sort	Ceramic Electrolytic Mylar Polyester Styrol
Voltage	No indicated 50WV

3. Be sure to make your orders of resistors and capacitors with value, voltage, tolerance and sort.
4. When replacing capacitors marked with *, use specified ones stated on parts list since required temperature characteristics.

CIRCUIT BOARD DIAGRAM

- : +B
- : SIGNAL
- : GROUND

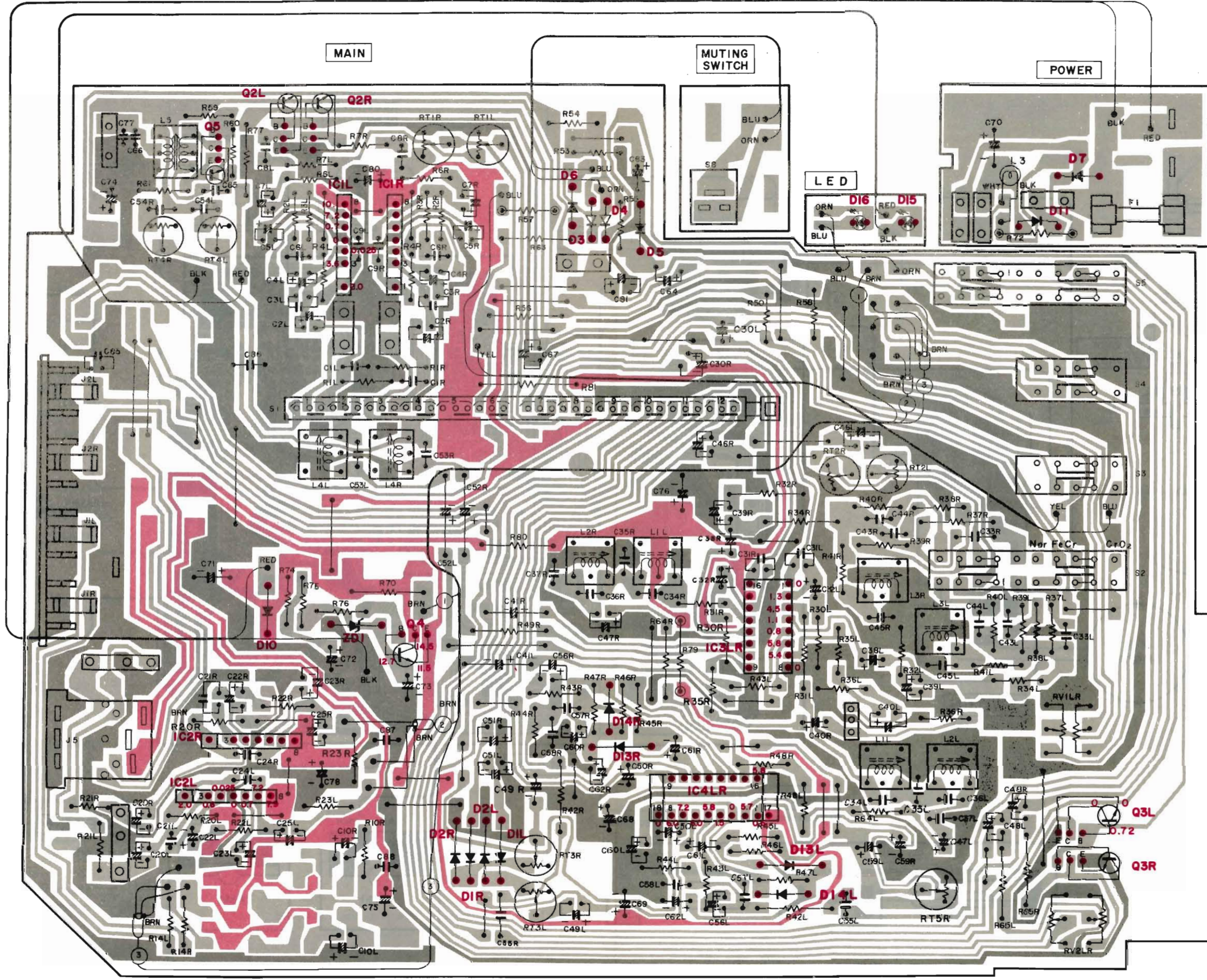

WIRING DIAGRAM

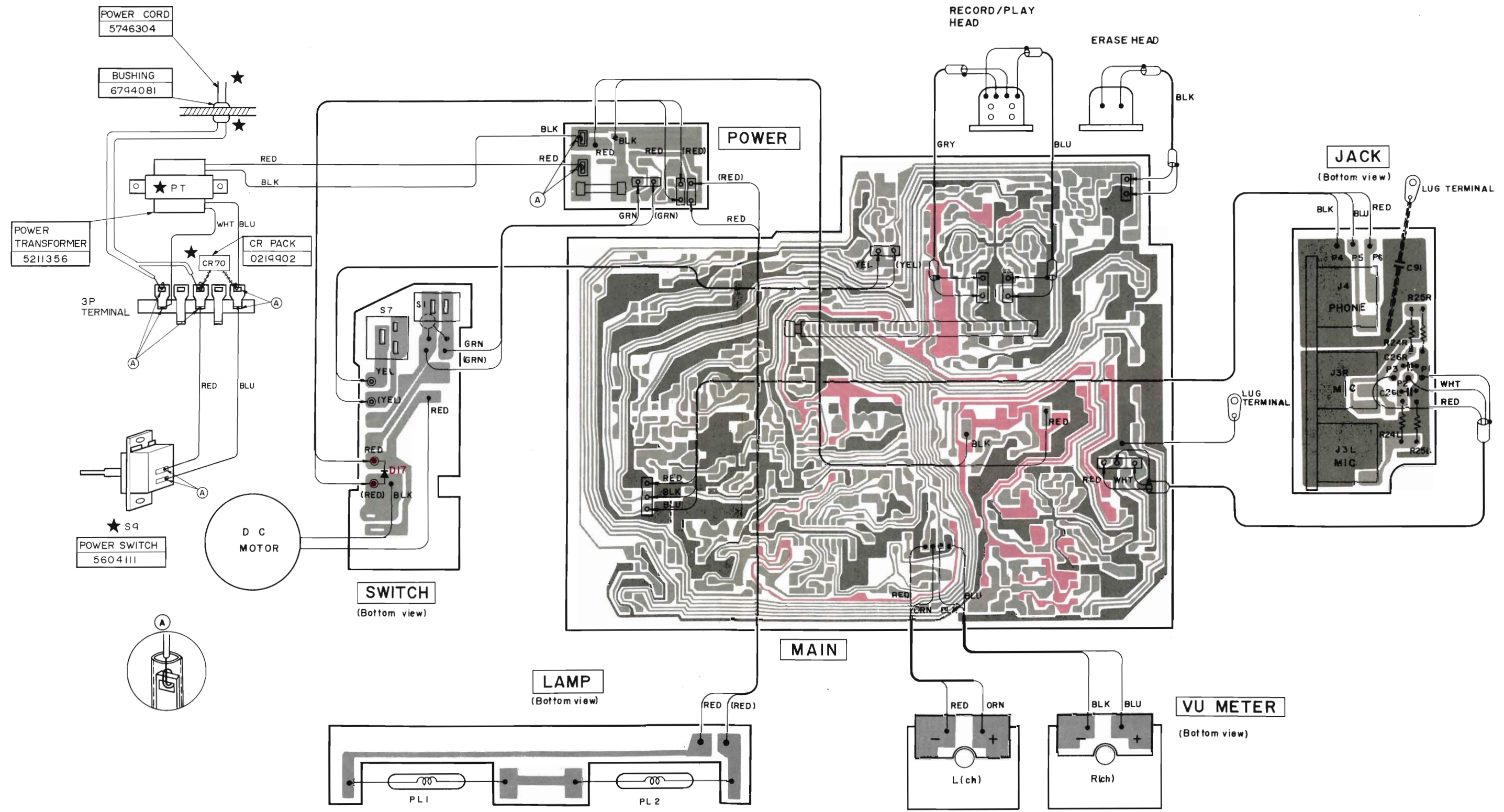

REPLACEMENT PARTS LIST

SYMBOL-NO	P-NO	DESCRIPTION	SYMBOL-NO	P-NO	DESCRIPTION
RESISTORS					
RT1LR	0151886	VARIABLE 10KOHM B	L2LR	5260215	TRAP COIL 33HH
RT2LR	0151886	VARIABLE 10KOHM B	L3LR	5260215	TRAP COIL 33HH
RT3LR	0151883	SEMI VARIABLE 1KOHM B	L4LR	5260215	TRAP COIL 33HH
RT4LR	0151889	SEMI VARIABLE 100K OHMB	L5	5260092	OSCILLATOR TRANS
RT5	0151886	VARIABLE 10KOHM B	MISCELLANEOUS		
RV1LR	5000343	VARIABLE 20K OHM(B)		5676082	PIN JACK
RV2LR	5000142	VARIABLE 10K OHM(B)		5746304	POWER CORD
SEMI-CONDUCTORS					
D 1LR	5330721	DIODE GERMANIUM 1N34A 10MHZ 50MW	F1	5720175	FUSE 0.8A
D 2LR	5330721	DIODE GERMANIUM 1N34A 10MHZ 50MW	J3LR	5679402	MIC JACK
D 3	5340022	VARIATOR SILICON HV-46 10KHZ 100MW	J4	5679402	MIC JACK
D 4	5340022	VARIATOR SILICON HV-46 10KHZ 100MW	J5	5651141	5P DIN SOCKET
D 5	5330341	RECTIFIER SILICON W0-6A 60HZ 1.7W	LM1LR	5554331	LEVEL METER
D 6	5330572	DIODE SILICON 1S2473HC 100MHZ 250MW 10NS	PL1	5765051	LAMP ASSEMBLY
D 7	5330341	RECTIFIER SILICON W0-6A 60HZ 1.7W	PL2	5765051	LAMP ASSEMBLY
D 8	5330572	DIODE SILICON 1S2473HC 100MHZ 250MW 10NS	PL3	5762036	PILOT LAMP
D 9	5330572	DIODE SILICON 1S2473HC 100MHZ 250MW 10NS	S 1	5623303	SLIDE SWITCH
D10	5330341	RECTIFIER SILICON W0-6A 60HZ 1.7W	S 2	5604162	LEVER SWITCH
D11	5330341	RECTIFIER SILICON W0-6A 60HZ 1.7W	S 3	5604161	LEVER SWITCH
D12	5330572	DIODE SILICON 1S2473HC 100MHZ 250MW 10NS	S 4	5604164	LEVER SWITCH
D13LR	5330721	DIODE GERMANIUM 1N34A 10MHZ 50MW	S 5	5604163	LEVER SWITCH
D14LR	5330572	DIODE SILICON 1S2473HC 100MHZ 250MW 10NS	S 8	5603251	LEAF SWITCH
D15	5380101	LED SLP-24B	S 9	5604111	LEVER SWITCH
D16	5380111	LED SLP-224B	FOR ACCESSORIES		
D17	5330341	RECTIFIER SILICON W0-6A 60HZ 1.7W		5892291	PATCH CORD
IC1LR	5350251	IC HA1406		7740321	HEAD CLEANING STICK
IC2LR	5350251	IC HA1406	CAPACITORS		
IC3LR	5350462	IC HA11122	CR70	0219902	CR PACK 120 OHM 0.0033MF 450V
IC4LR	5350561	IC HA 11226			
Q2LR	5321292	TRANSISTOR 2SC1740S			
Q3LR	5321292	TRANSISTOR 2SC1740S			
Q4	5320643	TRANSISTOR SILICON 2SC1162 150MHZ 10W			
Q5	5320613	TRANSISTOR SILICON 2SC1213C 80MHZ 400MW			
ZD1	5330531	ZENER DIODE SILICON HZ-12A 10MHZ 40 0MW			
TRANSFORMERS					
PT	5211356	POWER 5VA, 300G			
COILS					
L1LR	5260215	TRAP COIL 33HH			

SYMBOL-NO	P-NO	DESCRIPTION	SYMBOL-NO	P-NO	DESCRIPTION
FOR CASSETTE DECK ASSEMBLY (A)					
1	6372604	R FLYWHEEL ASSEMBLY	50	5603091	LEAF SWITCH
2	7778858	WASHER	51	5330341	RECTIFIER SILICON W0-6A 60HZ 1.7W
3	7771912	NYLON WASHER	52	6307924	SPRING
4	6357082	FLYWHEEL BELT	53	7287413	PAUSE LOCK PLATE ASSEMBLY
5	6354031	BELT	54	6323732	STOP LEVER SPRING
6	5572752	DC MOTOR	55	6741521	LEVER ASSEMBLY
7	6576083	RUBBER PAD	56	6741702	STOP ARM
8	7574591	SPACER	57	6348663	PLAY GEAR
9	7771631	WASHER - 2.8MMD	58	6303112	HEAD PIN SPRING
10	0711309	PAN HEAD SCREW - 2.6MMD X 9MM	59	6741514	GEAR MOVING ARM
11	7297241	BRAKE PLATE	60	6324811	SPRING
12	6586071	RUBBER	61	6741495	PLAY ARM
13	6308072	SPRING	62	6324591	SPRING
14	7296065	PLAY PLATE ASSEMBLY	63	6741551	THRUST SUPPORT
15	7574831	SPACER	64	6255946	BUTTON ASSEMBLY
16	6743587	PRESSURE ROLLER ARM ASSEMBLY	65	7290493	RECORDING ARM
17	7778656	POLYESTER WASHER	66	7740293	CUSHION
18	6300792	CASSETTE HOLDER SPRING	67	7287462	EJECT ARM
19	7287062	RECORD SLIDER ASSEMBLY	68	7574832	SPACER
20	6324436	SPRING	69	7107052	CASSETTE HOLDER ASSEMBLY
21	7189545	LOCKING WASHER	70	6319693	SPRING
22	7296661	HEAD PLATE ASSEMBLY	71	6325061	SPRING
23	5444521	RECORD PLAYBACK HEAD	72	7290501	GOVERNOR
24	5445131	ERASE HEAD	73	6744101	S ARM
25	7771441	WASHER - 2 MMD	74	6560234	S RUBBER
26	7768181	HEAD SPACER	75	6300843	SPRING
27	6321243	SPRING	FOR CASSETTE DECK ASSEMBLY (B)		
28	6742315	HEAD PLATE	76	7291033	RECORDING HOLDER ASSEMBLY
29	6300982	SPRING	77	7541181	RECORDING ROD
30	7287114	REWIND SLIDER	78	7291023	RECORDING ARM ASSEMBLY
31	6301011	LOCK LEVER SPRING	79	7574352	GUIDE COLER
32	7287104	PLAY SLIDER	80	6354481	BELT
33	6325842	SPRING	81	5559022	COUNTER
34	7287095	FF SLIDER	MISCELLANEOUS		
35	6300982	SPRING	85	6670908	FRONT PANEL ASSEMBLY
36	6741485	SLIDER COVER	86	6091056	CASSETTE DOOR ASSEMBLY
37	6300142	SPRING	87	6255951	FUNCTION KNOB (FF,REW,PAUSE,EJECT)
38	6307871	LOCK PLATE SPRING	88	6255952	FUNCTION KNOB (RECORD)
39	7287138	PAUSE SLIDER ASSEMBLY	89	6255953	FUNCTION KNOB (PLAY)
40	6300073	SPRING	90	6255961	FUNCTION KNOB (STOP)
41	7286962	PAUSE LOCK ARM	91	6256091	LEVER KNOB (GOLD)
42	6307933	SPRING	92	6299851	KNOB ASSEMBLY (GOLD)
43	7574665	SPACER	93	6286581	KNOB ASSEMBLY (GOLD)
44	6421321	RELAY PULLEY	94	6286701	KNOB (GOLD)
45	7778851	WASHER	95	6328411	SPRING
46	6354381	SENSING BELT			
47	7127937	GEAR PLATE ASSEMBLY			
48	8711425	PAN HEAD SCREW-3MMDX25MM			
49	5632712	SWITCH			

EXPLODED VIEW
Deck chassis

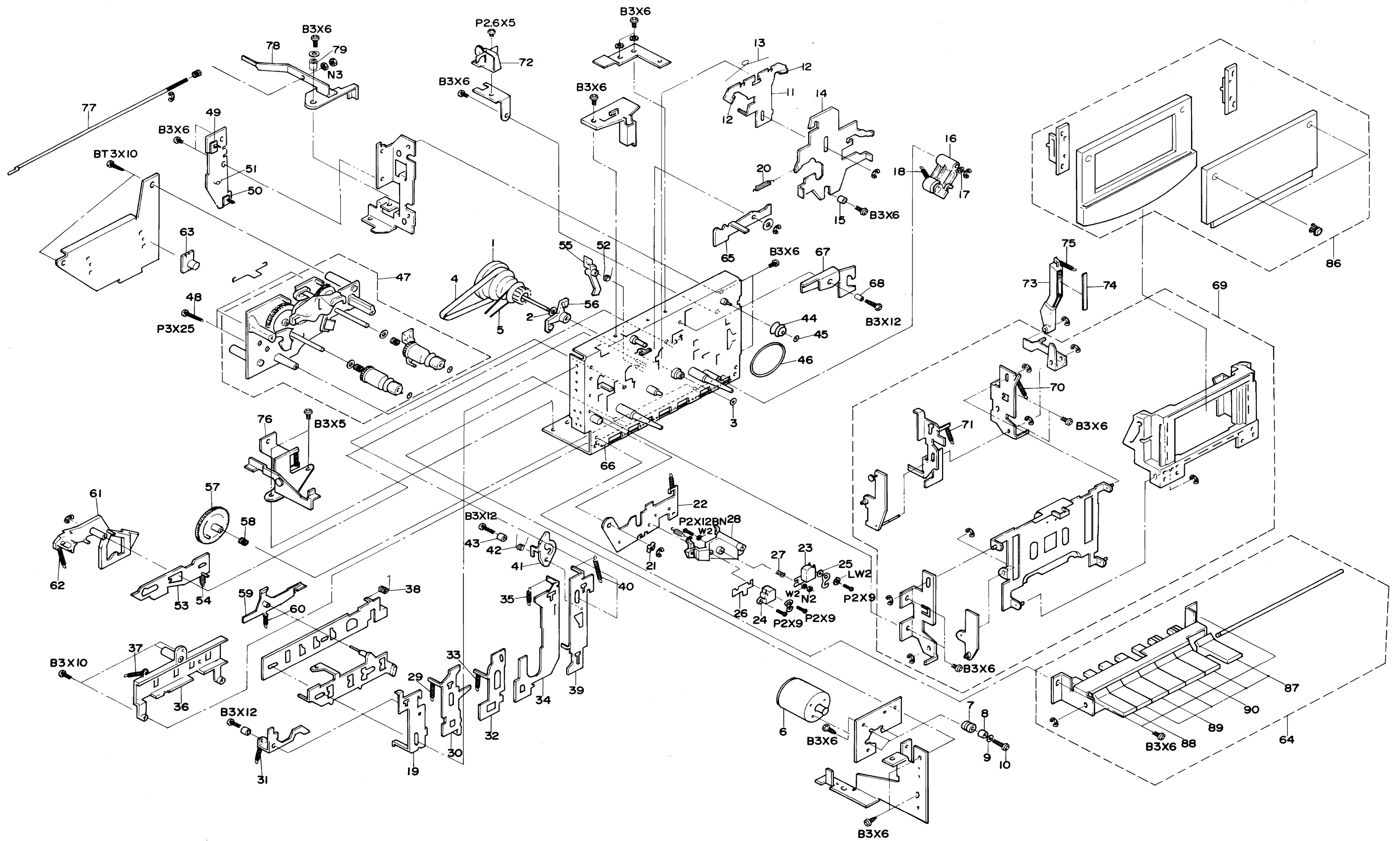

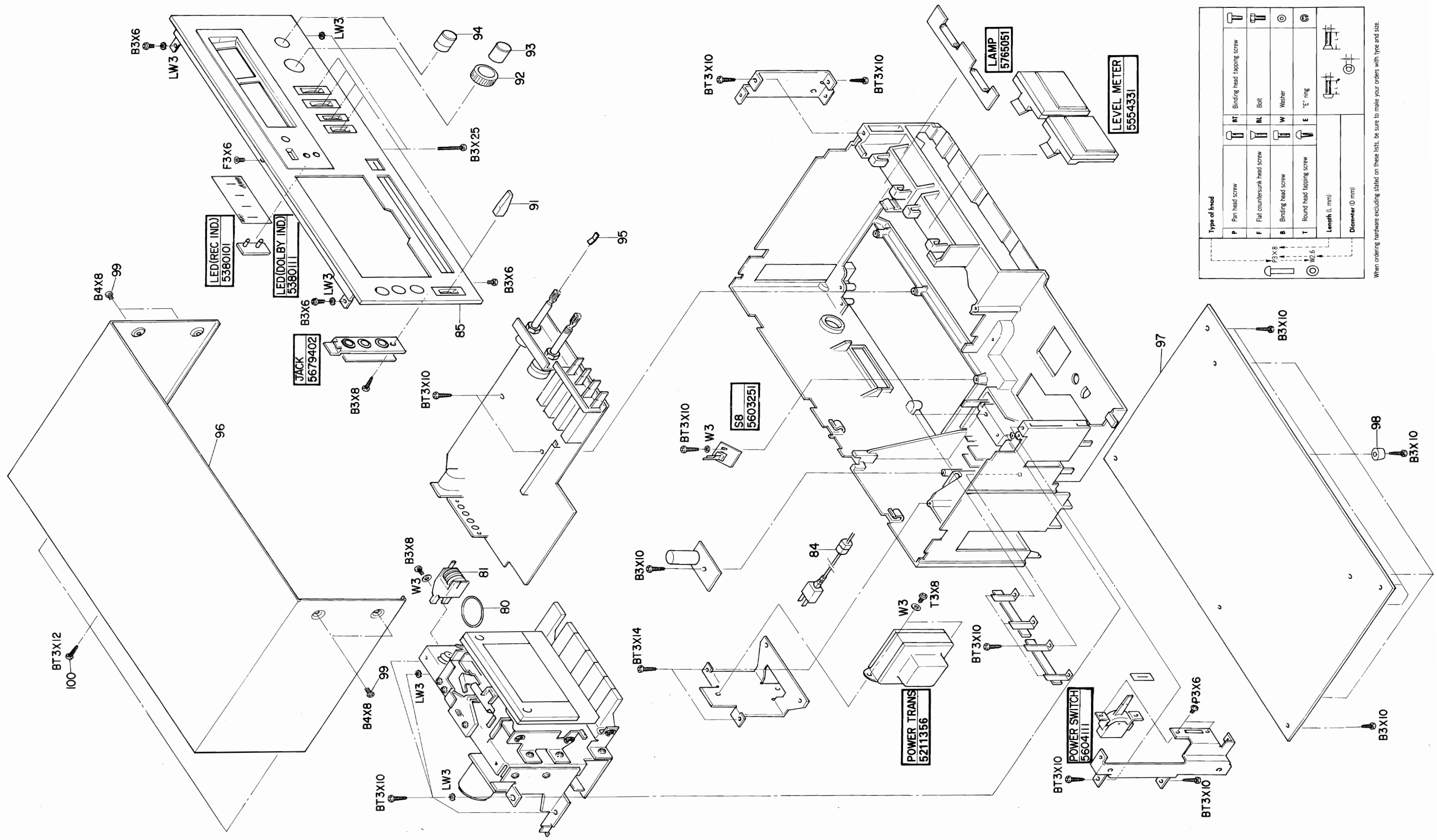

Type of head	BT	BL	W	E	
P	Pin head screw	Flat countersunk head screw	Binding head screw	Round head tapping screw	
F	Pin head screw	Flat countersunk head screw	Binding head screw	Round head tapping screw	
B	Binding head screw	Binding head screw	Binding head screw	Round head tapping screw	
T	Round head tapping screw	Round head tapping screw	Round head tapping screw	Round head tapping screw	
Length (L mm)					
Diameter (D mm)					

When ordering hardware excluding stated on these lists, be sure to make your orders with type and size.

SYMBOL-NO	P-NO	DESCRIPTION	SYMBOL-NO	P-NO	DESCRIPTION
		MISCELLANEOUS			
96	6147404	UPPER COVER	98	6739721	RUBBER LEG
97	6147415	BOTTOM COVER (SILVER)	99	8798412	BIND TAPPING SCREW-3MMDX12MM(BLACK)
			100	8747608	BIND SCREW-4MMDX8MM(BLACK)

BLOCK DIAGRAM

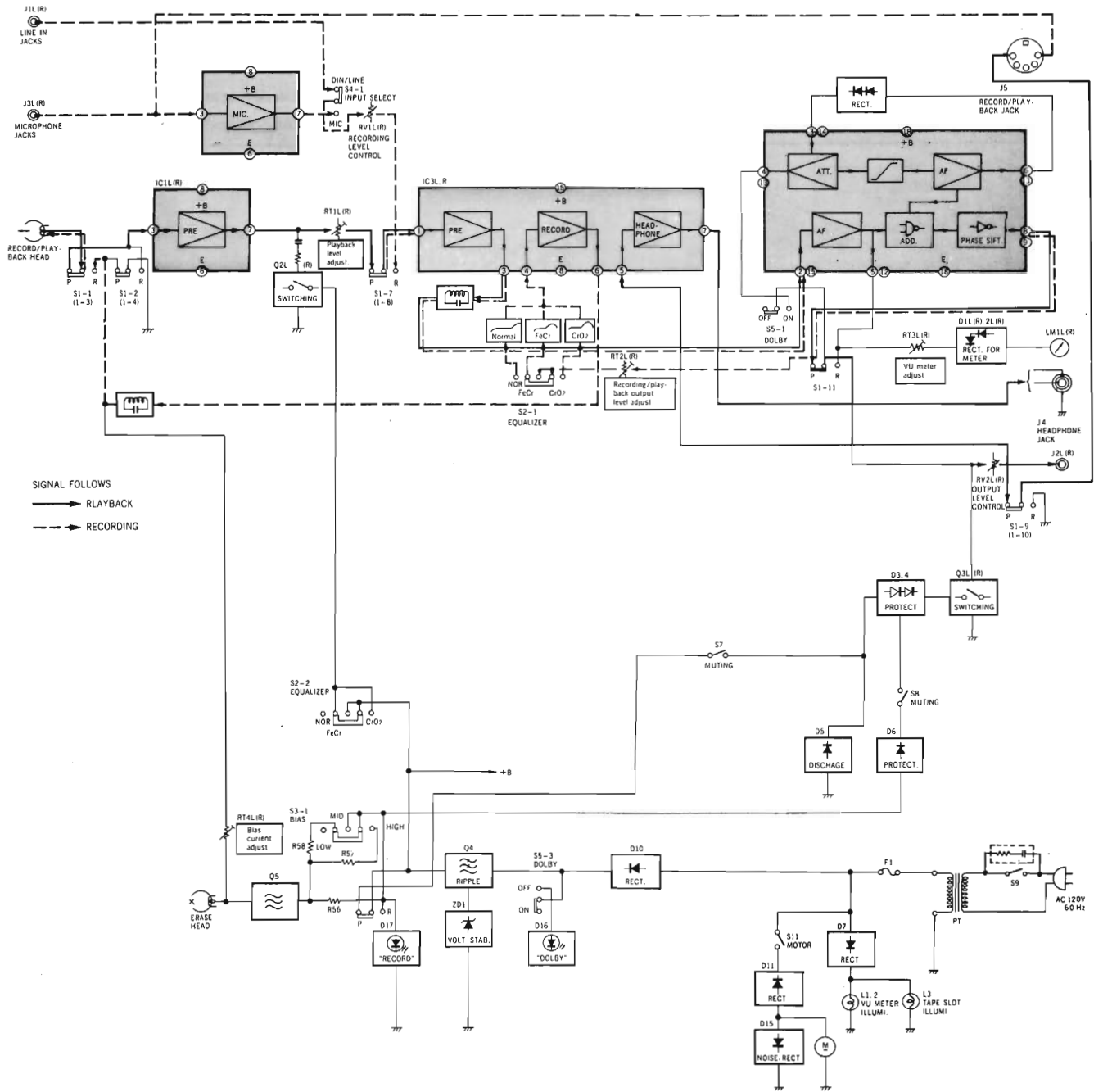

HITACHI SALES CORPORATION OF AMERICA
NATIONAL HEADQUARTERS
 401 West Artesia Boulevard, Compton, California 90220
 Tel. 213-537-8383
Eastern Regional Office
 1200 Wall Street West, Lyndhurst, New Jersey 07071
 Tel. 201-935-8980
Mid-Western Regional Office
 1400 Morse Ave., Elk Grove Village, Ill. 60007
 Tel. 312-593-1550
South-Western Regional Office
 2050 Stemmons Freeway, Dallas, Texas 75207
 Tel. 214-747-3547
Western Regional Office
 401 West Artesia Boulevard, Compton, California 90220
 Tel. 213-537-8383