

# HITACHI

## SERVICE MANUAL

TK

No. 1687E

# D-E44

(U,C,FS,BS,AU,W)

### CONTENTS

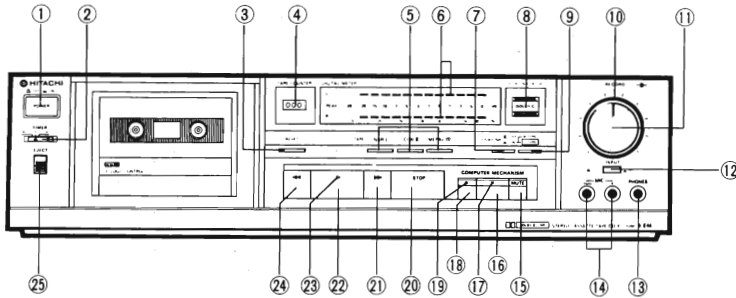

Specifications . . . . .	2
Disassembly . . . . .	2
Adjustments . . . . .	3
Inspection of mechanism . . . . .	5
Lubrications . . . . .	5
Schematic diagram . . . . .	6
Circuit board diagram . . . . .	9
Wiring diagram . . . . .	11
Replacement parts list . . . . .	13, 19, 23
Exploded view (Mechanism-FL-90F) . . . . .	15
Exploded view (Cabinet) . . . . .	17
IC501 pin function table . . . . .	20

### KEY TO ILLUSTRATIONS

- |                                   |                       |
|-----------------------------------|-----------------------|
| ① POWER (MAINS) SWITCH            | ⑭ MICROPHONE SOCKETS  |
| ② TIMER SWITCH                    | ⑮ REC. MUTE BUTTON    |
| ③ TAPE COUNTER RESET BUTTON       | ⑯ PAUSE BUTTON        |
| ④ TAPE COUNTER                    | ⑰ PAUSE INDICATOR     |
| ⑤ TAPE SELECT SWITCHES            | ⑱ RECORD BUTTON       |
| ⑥ DIGITAL PEAK METERS             | ⑲ RECORD INDICATOR    |
| ⑦ DOLBY NR SWITCH                 | ⑳ STOP BUTTON         |
| ⑧ DOLBY C NR INDICATOR            | ㉑ FAST FORWARD BUTTON |
| ⑨ DOLBY B/C NR CHANGE OVER SWITCH | ㉒ PLAYBACK BUTTON     |
| ⑩ RECORDING LEVEL CONTROL (RIGHT) | ㉓ PLAYBACK INDICATOR  |
| ⑪ RECORDING LEVEL CONTROL (LEFT)  | ㉔ REWIND BUTTON       |
| ⑫ INPUT SELECT SWITCH             | ㉕ EJECT BUTTON        |
| ⑬ HEADPHONE SOCKET                |                       |

### SAFETY PRECAUTION

The following precautions should be observed when servicing.

1. Since many parts in the unit have special safety-related characteristics, always use genuine Hitachi's replacement parts. Especially critical parts in the power circuit block should not be replaced with other makes. Critical parts are marked with  $\triangle$  in the schematic diagram, and circuit board diagram.
2. Before returning a repaired unit to the customer, the service technician must thoroughly test the unit to ascertain that it is completely safe to operate without danger of electrical shock.

SPECIFICATIONS AND PARTS ARE SUBJECT TO CHANGE FOR IMPROVEMENT

## STEREO CASSETTE TAPE DECK

February 1982

TOKAI WORKS

## SPECIFICATIONS

Semiconductors:		Dolby NR OFF:	58 dB (A weighted, Reference 3% T.H.D.)
Modules:	1		58 dB*
ICs:	6	Wow and Flutter:	0.04% (WRMS)
Transistors:	33		0.13%*
Diodes:	27	Input Sensitivity and Impedance:	
LEDs:	3	Microphone:	0.5 mV, 300 ohms ~5k ohms
Track System:	4 track 2 channel stereo	Line in:	80 mV, 50k ohms or more
Tape:	Cassette tape (C-30, 60, 90)	Output Level:	500 mV
Tape Speed:	4.75 cm/s	Output Load Impedance:	
Recording System and		Line out:	50k ohms or more
Bias Frequency:	AC bias, 85 kHz	Headphone:	8 ohms ~2k ohms
Erasing System:	AC erase	Distortion:	1.0% (1 kHz, 160 nWb/m)
Erase Ratio:	65 dB or more (at 1 kHz)	Crosstalk:	60 dB or more (at 1 kHz)
Frequency Response:		Channel Separation:	30 dB or more (at 1 kHz)
NOR-I:	20 Hz~16 kHz	Power Supply:	AC 120V, 60 Hz(U, C)
	30 Hz~15 kHz ( $\pm 3$ dB)		AC 220V, 50 Hz(FS)
	30 Hz~15 kHz*		AC 240V, 50 Hz(BS, AU)
CrO <sub>2</sub> -II:	20 Hz~17 kHz		AC 100 - 110V, 115 - 127V,
	30 Hz~16 kHz ( $\pm 3$ dB)		200 - 220V, 230 - 250V,
	30 Hz~16 kHz*		50/60 Hz(W)
METAL-IV:	20 Hz~17 kHz	Power Consumption:	22W
	30 Hz~16 kHz ( $\pm 3$ dB)	Dimensions:	110(H) x 435(W) x 282(D) mm
	30 Hz~16 kHz*	Weight:	4.6 kg
S/N (Signal to Noise Ratio):		Motor:	Electronically controlled DC motor
Dolby C NR ON:	72 dB (A weighted, Reference 3% T.H.D.)	Heads:	Metal SL R & P head
	72 dB*		Three-gap ferrite Erase head
Dolby B NR ON:	66 dB (A weighted, Reference 3% T.H.D.)		
	66 dB*		

\* According to DIN 45 500

## DISASSEMBLY

## 1. Cassette door

Depress the eject button to open the cassette door.  
Remove (A) (two) nylon rivets and remove the cassette door.

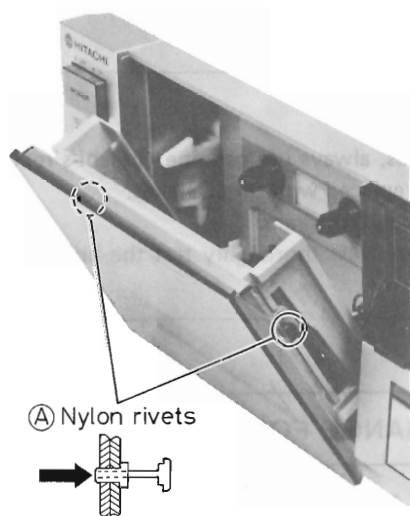

## 2. Top cover

Remove (B) and (C) (two) screws.

## 3. Bottom cover

Remove (C), (D), (E) and (F) (five) screws.

## 4. Front panel

Remove (G) and (H) (seven) screws. When removing the front panel, be careful that the lead wires are not damaged.

## 5. Cassette chassis

Remove (F), (H) and (I) (five) screws.

## 6. Main PC board

After removing the front panel, remove (E), (J) and (K) (five) screws.

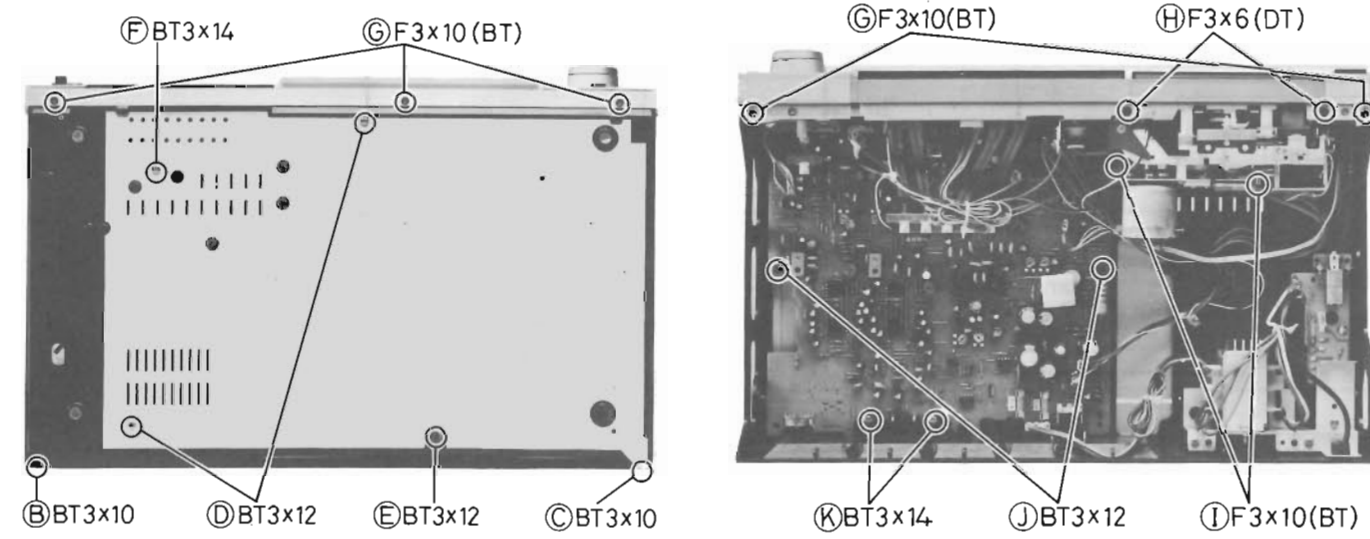

**ADJUSTMENTS**

Perform the following adjustments in the sequence stated after cleaning the heads, pressure roller and capstan with a head cleaning stick moisted in alcohol. Also, unless

otherwise specified, set the switches and controls to the positions indicated in the table.

Symbol No.	Switches and Controls	Position	Symbol No.	Switches and Controls	Position
S2-1 ~ S2-3	Tape select switches	NOR-I	S4	Timer switch	OFF
S2-4	Dolby NR switch	OFF	RV01	Record level controls	MAX.
S3	Input select switch	LINE	RV02	Output level control	MAX.

\* According to DIN45 500

Item	Adjustments	Measuring Instrument and Connection			Check Tape	Mode	Adjusted Position	Adjusted Value	Remarks
		Measuring Instrument	Input Terminal	Output Terminal					
1	Tape speed	• Frequency counter	—	LINE OUT	MTT-111, 3000 Hz (3150Hz*)	Playback	Semi-variable resistor in the motor	3000Hz +30Hz -10 (3150Hz*)	See Note 1
2	Head azimuth	• VTVM	—	LINE OUT	MTT-216 or MTT-316 12.5 kHz	Playback	Azimuth adjusting screw	Output Max.	See Note 2
3	Playback gain	• VTVM	—	TP1L, R	MTT-150 (400Hz, 200 nWb/m)	Playback	RT01L, R	580 mV	See Note 3
4	Digital peak meter	• Audio oscillator (400Hz) • Attenuator • VTVM	LINE IN	TP1L, R	—	Record	RT201L, R	0 dB indicator lights	See Note 4

Item	Adjustments	Measuring Instrument and Connection			Check Tape	Mode	Adjusted Position	Adjusted Value	Remarks
		Measuring Instrument	Input Terminal	Output Terminal					
5	Bias current	• Audio oscillator (1.2kHz/12 kHz 0dB - 20dB) • Attenuator • VTVM	LINE IN	LINE OUT	Hitachi UD tape	Record/playback	RT401L, R	Output difference within ±0.5dB	See note 5
6	Record level	• Audio oscillator (400Hz) • Attenuator • VTVM	LINE IN	TP1L, R	Hitachi UD tape	Record/playback	RT02L, R	580mV -10dB ±0.5dB	See Note 6
7	(1) Bias frequency (2)	• Frequency counter	—	TP2L, R	—	Record	L401	85±0.5kHz	See Note 7

**Note:**

- Adjust within 30 sec. after heat-running for more than 20 minutes.
- When the maximum values of both channels are different, adjust to the maximum value of the L channel. In this case, the difference between the maximum values of both channels should be within 2 dB.
- Playback a test tape (MTT-150, 400 Hz 200 nWb/m) and adjust RT01L, R so that the level of TP1L, R becomes 580 mV.
- 1) Feed a 400 Hz signal to the LINE IN jacks in the recording mode and adjust the audio oscillator output so that the level of TP1L, R becomes 580 mV.  
2) Then, adjust the attenuator to lower the input level by 0.5 dB.  
3) Adjust RT201L, R so that the 0 dB indicators of the digital peak meter lights.
- 1) Set RT02L, R to the center.  
2) Feed a 1.2 kHz signal to the LINE IN jacks in the recording mode and adjust the audio oscillator output so that the digital peak meter indicates 0 dB. Then, adjust the attenuator to lower the input level by 20 dB.  
3) Record the signal on Hitachi UD tape with the conditions of item 2), then continue to record with the audio oscillator frequency set to 12 kHz.  
4) Playback the recorded signal and adjust RT401L, R so that the output level difference between two frequencies is within ±0.5 dB measured at the LINE OUT jacks.
- 1) Feed a 400 Hz signal to the LINE IN jacks in the recording mode and adjust the audio oscillator output so that the level of TP1L, R becomes 580 mV. Then, adjust the attenuator to lower the input level by 10 dB.  
2) Record the signal on Hitachi UD tape with the conditions of item 1).  
3) Playback the recorded signal and adjust RT02L, R so that the level of TP1L, R becomes 580 mV -10dB ±0.5 dB.
- Set the tape select switches (S2-1 ~ S2-3) to the Metal position. Adjust L401 so that the bias frequency of TP2L, R becomes 85 ± 0.5 kHz.

**INSPECTION OF MECHANISM**

Check Item	Reference Value	Remarks
1 Pressure of pressure roller	200 to 270g	Note 1
2 Tape driving force	120g or more	
3 Torque	Take-up	40 to 65g - cm
	Fast forward	75 to 110g - cm
	Rewind	75 to 110g - cm
4 Back-tension	Take-up reel	1.7 to 5g - cm
	Supply reel	2.5 to 4.0g - cm
5 Brake-torque	Take-up reel	50 to 100g - cm
	Supply reel	50 to 100g - cm
6 Head plate return strength	200g or more	Measure in stop mode
7 Play lock allowance	300g or more	Measure in playback mode

**Note 1. Pressure of pressure roller**

Set this unit in the playback mode and press the pressure roller in the direction of the arrow using a fan type tension gauge, and measure the pressure when the pressure roller is released from the capstan.

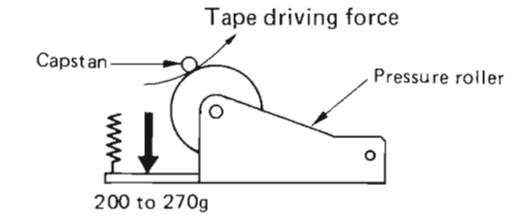

**LUBRICATIONS**

Lubricate one or two drops of oil to rotating point or lubricate grease to sliding point. Lubricate the respective parts listed once every 1000 hours or once a year under normal conditions of use. Avoid oiling them excessively, or rotation may become irregular because of oil splashes.

	Lubrication	Oil or Grease
Rotary section	Metal and metal	Pan motor oil (10W-40)
	Mold and metal	Sonic slider oil (#1600)
Sliding section	Metal and metal	Hitasol (MO-138)
	Mold and mold Mold and metal	White grease (FL-LUBE-A)
Spring resonance prevention		Floil (GB-TS-1)



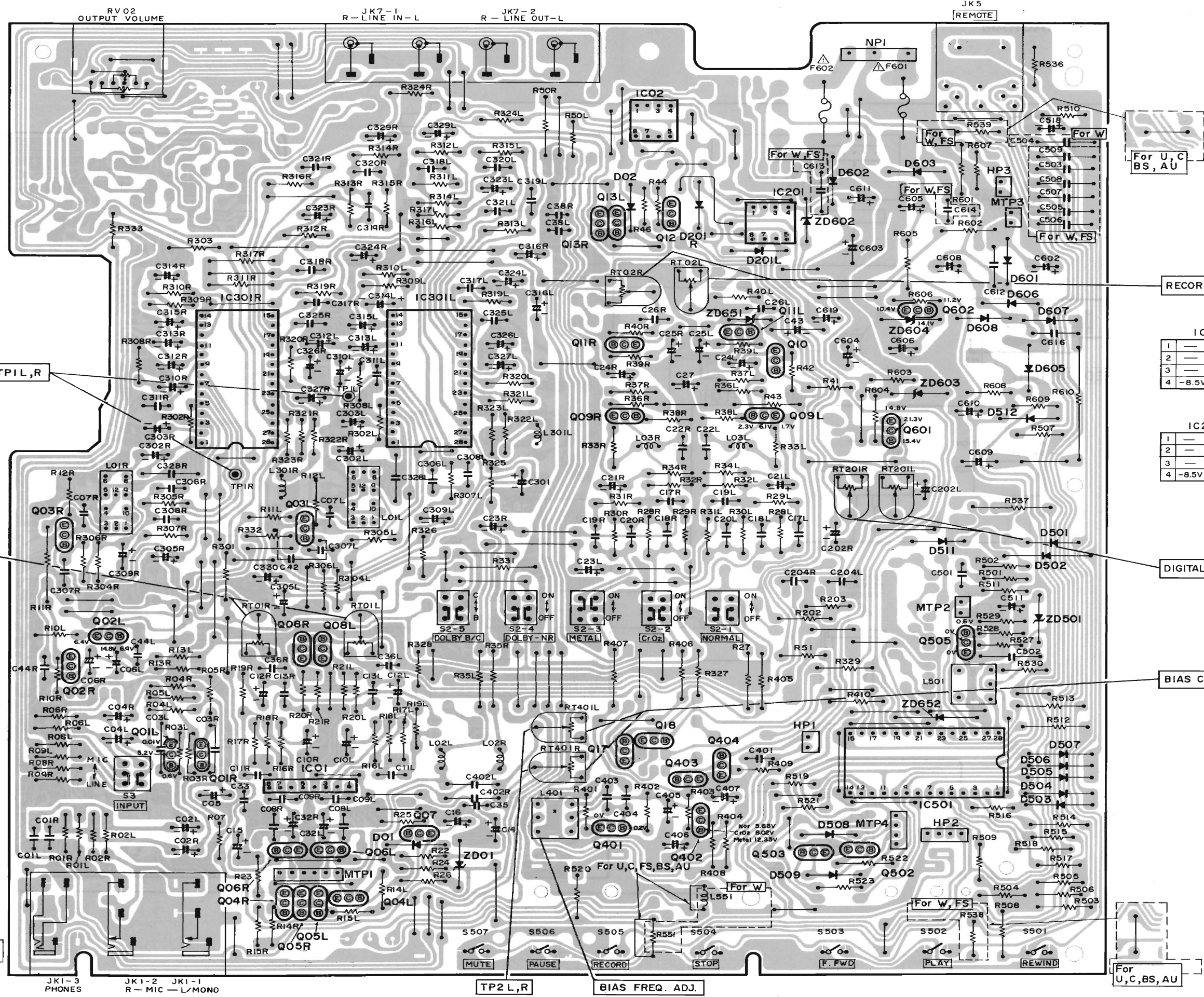

IC301L,R

1	7.2V	15	7.2V
2	7.2V	16	7.2V
3	0V	17	7.2V
4	7.2V	18	7.2V
5	7.2V	19	7.2V
6	7.2V	20	2.1V
7	7.3V	21	3.6V
8	7.2V	22	7.4V
9	7.2V	23	7.4V
10	0.01V	24	7.4V
11	0.9V	25	7.4V
12	0.9V	26	5.7V
13	0.01V	27	0V
14	6.5V	28	14.3V

IC02

1	—	5	0V
2	—	6	0V
3	—	7	0V
4	-8.5V	8	10.8V

IC201

1	—	5	0V
2	—	6	0V
3	—	7	-0.4V
4	-8.5V	8	10.6V

IC01

1	1.4V	5	0V
2	0.9V	6	—
3	4.3V	7	—
4	7.5V	8	—

PLAYBACK GAIN ADJ.

RECORD LEVEL ADJ.

DIGITAL PEAK METER ADJ.

BIAS CURRENT ADJ.

BIAS FREQ. ADJ.

MAIN

JK1-3 PHONES JK1-2 R-MIC L-MONO JK1-1

TP2 L,R

For U,C,BS,AU

WIRING DIAGRAM

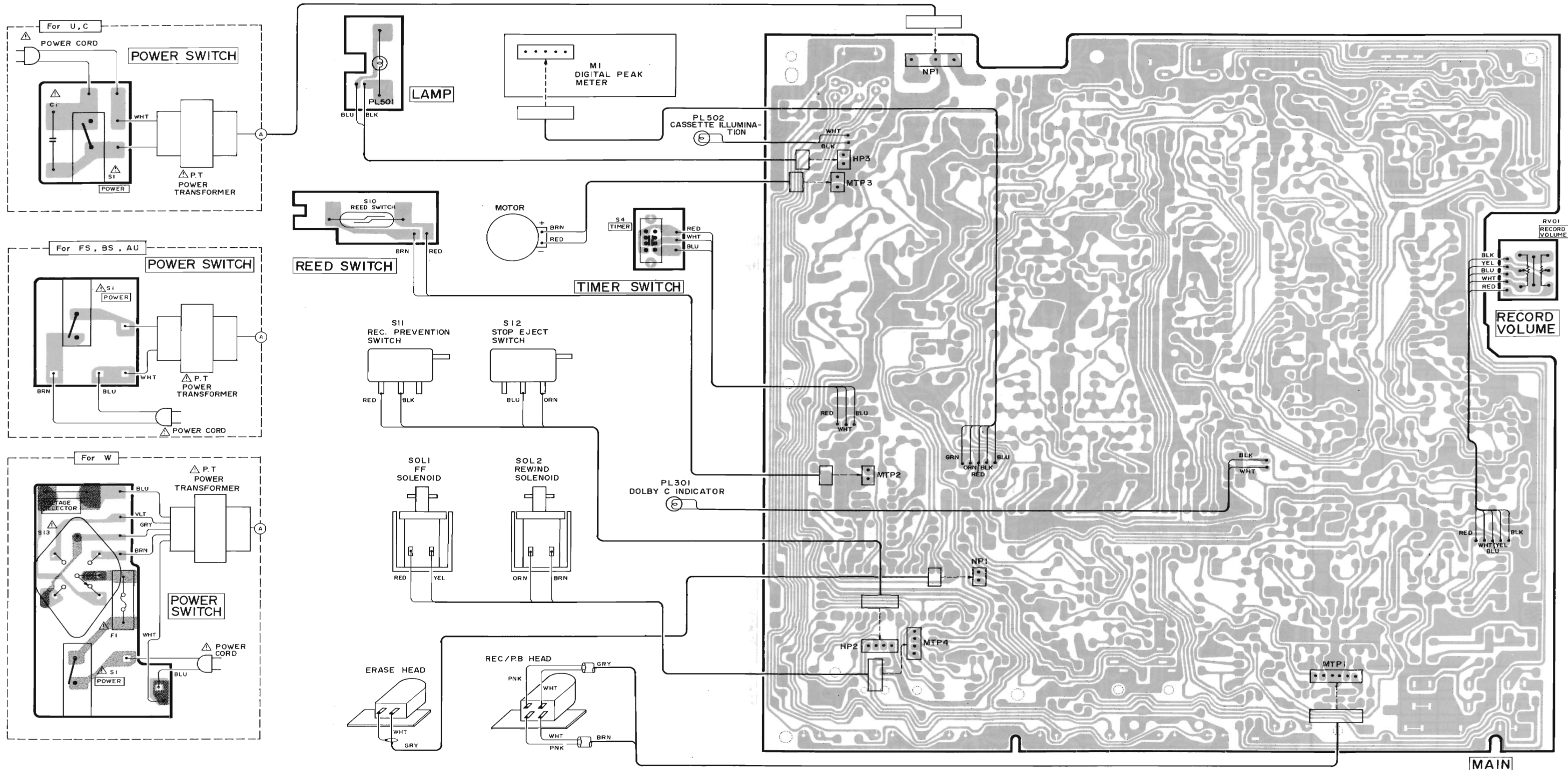

## REPLACEMENT PARTS LIST

SYMBOL-NO	P-NO	DESCRIPTION	SYMBOL-NO	P-NO	DESCRIPTION
CAPACITORS			IC301LR	5355111	IC HA12038
△C 1	0249781	CERAMIC CAPACITOR 0.01MF (U,C)	IC501	5359725	IC MPD554-81
C 03LR	0209023	CERAMIC DISC (RESISTOR SHAPE) 3300PF+-30%	LED501	5380481	LED SLR-54GC
C311LR	0268155	MYLAR 0.018MF+-5%	LED502	5380482	LED SLR54URC1
C318LR	0268153	MYLAR 5600PF+-5%	LED503	5380481	LED SLR-54GC
C321LR	0268157	MYLAR 3900PF+-5%	Q 01LR	5321298	TRANSISTOR 2SC1740LN-SE
C325LR	0268156	MYLAR 0.082MF+-5%	Q 02LR	5321298	TRANSISTOR 2SC1740LN-SE
C402LR	0209002	CERAMIC DISC (RESISTOR SHAPE) 220PF +-10%	Q 03LR	5323013	TRANSISTOR 2SC2603EF
C502	0209010	CERAMIC DISC (RESISTOR SHAPE) 1000P F+-10%	Q 04LR	5323031	TRANSISTOR 2SC1845EF
C503	0209010	CERAMIC DISC (RESISTOR SHAPE) 1000P F+-10% (FS)	Q 05LR	5323031	TRANSISTOR 2SC1845EF
C505-506	0209010	CERAMIC DISC (RESISTOR SHAPE) 1000P F+-10% (FS)	Q 06LR	5321194	TRANSISTOR 2SD467BC
C507	0209024	CERAMIC DISC (RESISTOR SHAPE) 4700P F+-30% (FS)	Q 07	5323041	TRANSISTOR 2SA992FE
C508-509	0209010	CERAMIC DISC (RESISTOR SHAPE) 1000P F+-10% (FS)	Q 08LR	5323013	TRANSISTOR 2SC2603EF
RESISTORS			Q 09LR	5321298	TRANSISTOR 2SC1740LN-SE
RT 01LR	5007478	SEMI VARIABLE 20K OHM	Q 10	5323013	TRANSISTOR 2SC2603EF
RT 02LR	5007477	SEMI VARIABLE 10K OHM	Q 11LR	5321194	TRANSISTOR 2SD467BC
RT201LR	5007478	SEMI VARIABLE 20K OHM	Q 12	5323013	TRANSISTOR 2SC2603EF
RT401LR	5007482	SEMI VARIABLE 250K OHM	Q 13LR	5321194	TRANSISTOR 2SD467BC
RV 01	5000846	VARIABLE RESISTOR 50K OHM(A)	Q 17	5323013	TRANSISTOR 2SC2603EF
RV 02	5000791	VARIABLE RESISTOR 10K OHM(B)	Q 18	5323013	TRANSISTOR 2SC2603EF
R301	0170542	FUSE RESISTOR 10 OHM+-5% 1/4W	Q401	5322651	TRANSISTOR 2SD667C
R331	0111039	OXIDE METAL FLIM 150 OHM+-5% 1W	Q402	5321213	TRANSISTOR 2SD468C
R408	0170543	FUSE RESISTOR 22 OHM+-5% 1/4W	Q403	5323013	TRANSISTOR 2SC2603EF
R604	0170542	FUSE RESISTOR 10 OHM+-5% 1/4W	Q404	5323013	TRANSISTOR 2SC2603EF
R605	0170541	FUSE RESISTOR 4.7 OHM+-5% 1/4W	Q502	5323071	TRANSISTOR 2SD947
R610	0171013	OXIDE METAL FILM 33 OHM+-5% 3W	Q503	5323071	TRANSISTOR 2SD947
SEMI-CONDUCTORS			Q505	5323013	TRANSISTOR 2SC2603EF
D 01	5330573	DIODE 1S2473	Q601	5323131	TRANSISTOR 2SD330ALE
D 02	5330573	DIODE 1S2473	Q602	5321213	TRANSISTOR 2SD468C
D201LR	5330573	DIODE 1S2473	ZD 01	5330311	ZENER DIODE SILICON HZ7A
D501	5330573	DIODE 1S2473	ZD501	5330311	ZENER DIODE SILICON HZ7A
D502	5330573	DIODE 1S2473	ZD602	5330321	ZENER DIODE HZ-9A
D503-507	5330573	DIODE 1S2473	ZD603	5330541	ZENER DIODE HZ-15
D508	5331841	DIODE ERB12-01	ZD604	5330552	ZENER DIODE HZ11B
D509	5331841	DIODE ERB12-01	ZD651	5330847	ZENER DIODE RD2.7E-B2
D511	5330573	DIODE 1S2473	ZD652	5330534	ZENER DIODE HZ12A3
D512	5330573	DIODE 1S2473	COILS		
D601-603	5331841	DIODE ERB12-01	L 01LR	5162171	DOLBY FILTER
D605	5330573	DIODE 1S2473	L 02LR	5120562	TRAP COIL
D606-608	5331841	DIODE ERB12-01	L 03LR	5150364	CHOKE COIL 3.3 MH
IC 01	5350713	IC BA328-LN	L301LR	5120564	TRAP COIL
IC 02	5352831	IC MPC4557C	L401	5260441	BIAS OSCILLATOR COIL
IC201	5350601	IC NJM4558D	L501	5132113	CHOKE COIL
			L551	5152107	CHOKE COIL (W)

(Continue to page 22)

SYMBOL-NO	P-NO	DESCRIPTION	SYMBOL-NO	P-NO	DESCRIPTION
MECHANISM (FL-90F)			26	6761815	RECORD PREVENTION ARM
1	7346821	CHASSIS BASE HOLDER ASSEMBLY	27	6761697	REEL BASE ASSEMBLY
2	6430887	PLAY GEAR	28	6414202	TURNTABLE ASSEMBLY (SUPPLY)
3	6761784	PLAY ARM	29	7786745	POLYESTER WASHER
4	6761821	PICK UP ARM	30	6414213	TURNTABLE ASSEMBLY (TAKE UP)
5	7339097	HEAD PLATE ASSEMBLY	31	7786745	POLYESTER WASHER
6	5449021	RECORD PLAYBACK HEAD	32	6761673	FF/REWIND ARM ASSEMBLY
7	5445351	ERASE HEAD	33	6761733	SELECT SLIDER
8	6761755	HEAD PLATE	34	5642921	DC SOLENOID
9	7775211	SPECIAL SCREW	35	7330726	SOLENOID PLATE ASSEMBLY
10	6321733	HEAD SPRING C	36	6761742	REWIND ARM
11	7771441	WASHER - 2 MMD	37	6581042	RUBBER FOR RECORD PREVENTION
12	7771442	WASHER-2MMD	38	6373751	FLYWHEEL ASSEMBLY
13	7771444	WASHER-2MMD	39	6430932	FLYWHEEL GEAR
14	6302375	SPRING	40	7787566	POLY SLIDER WASHER
15	6301022	SPRING	41	7772623	SPRING
16	7332762	HEAD SPACER	42	6534162	FLYWHEEL SUPPORT SPRING
17	7332764	HEAD SPACER	43	5576765	DC MOTOR ASSEMBLY
18	6761709	TAKE UP IDLER ASSEMBLY	44	6589591	RUBBER PLATE
19	6320578	SPRING FOR TAKE UP IDLER	45	7539007	SPECIAL SCREW
20	6990651	INSULATION PLATE FOR HEAD	46	6355193	BELT
21	7330581	PRESSURE ROLLER ARM ASSEMBLY	47	6357301	FLYWHEEL BELT
22	6301361	SPRING	48	6768913	CASSETTE HOLDER
23	7330666	EJECT HOLDER ASSEMBLY	49	7330603	CASSETTE HOLDER SUPPORT
24	5633361	PUSH SWITCH	50	6763431	DAMPER ASSEMBLY
25	0671310	DT SCREW-2.6MMDX10MM	51	6301723	SPRING FOR CASSETTE HOLDER

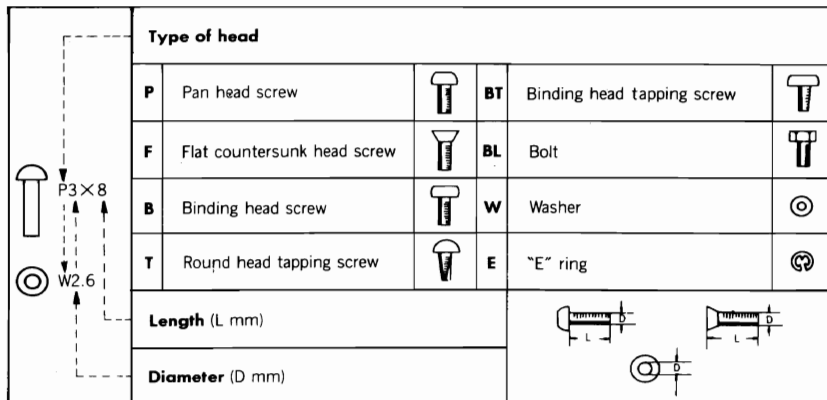

When ordering hardware excluding stated on these lists, be sure to make your orders with type and size.



EXPLODED VIEW (Mechanism – FL-90F)

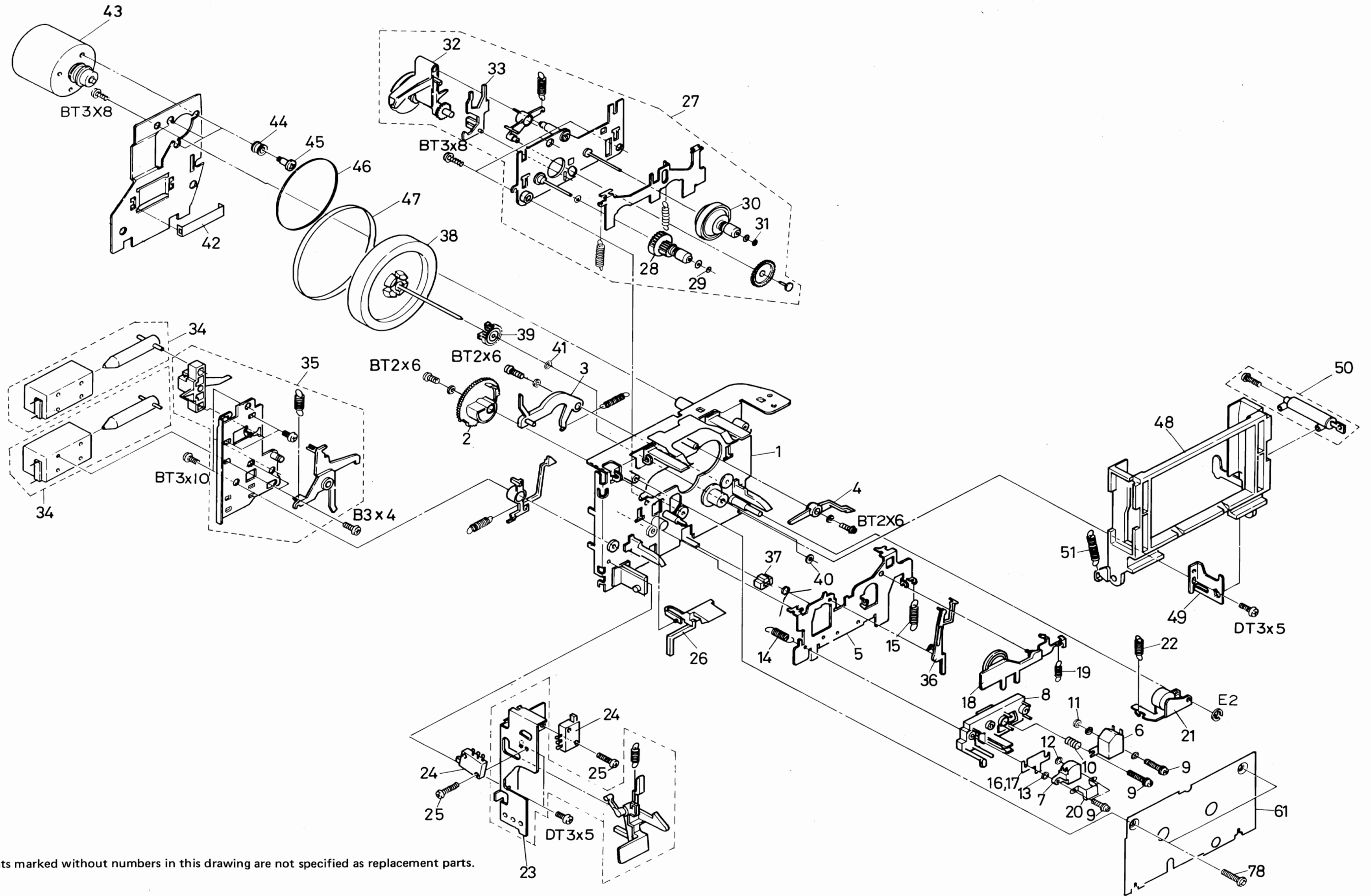

Note: Components marked without numbers in this drawing are not specified as replacement parts.

EXPLODED VIEW (Cabinet)

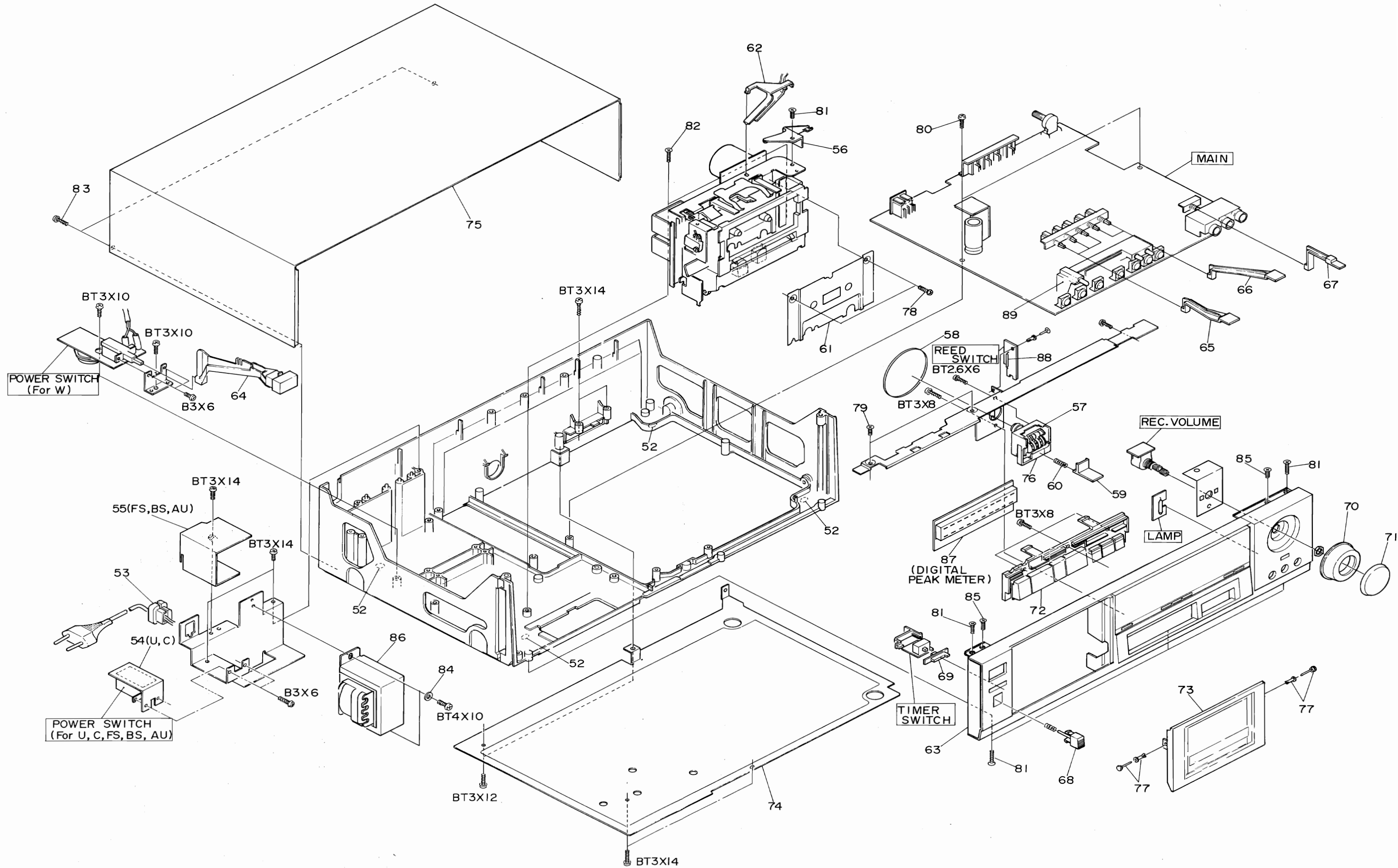

Note: Components marked without numbers in this drawing are not specified as replacement parts.

SYMBOL-NO	P-NO	DESCRIPTION	SYMBOL-NO	P-NO	DESCRIPTION
MISCELLANEOUS			71	3292411	KNOB ASSEMBLY (RECORD-L) [U, C, W, FS, AU]
52	7740603	FELT LEG	71	6288683	KNOB ASSEMBLY (RECORD-L) [BS]
△ 53	6794401	BUSHING (U, C, W, FS, AU)	72	4097705	FUNCTION BUTTON ASSEMBLY (U, C, W, FS, AU)
△ 53	6794411	BUSHING (BS)	72	6771793	FUNCTION BUTTON ASSEMBLY (BS)
54	7756282	TERMINAL COVER (U,C)	73	3948321	CASSETTE DOOR ASSEMBLY (U, C, W, FS, AU)
55	7758241	SWITCH COVER (FS,BS, AU)	73	6093772	CASSETTE DOOR ASSEMBLY (BS)
56	6767761	HOLDER	74	6044693	BOTTOM COVER
57	5559552	COUNTER	75	4434101	UPPER COVER (W,FS, AU)
58	6354663	BELT	75	4434352	UPPER COVER (U,C)
59	6056001	RESET BUTTON	75	6045505	UPPER COVER (BS)
60	6303115	SPRING FOR RESET BUTTON	76	6758054	RESET BODY
61	7341184	CASSETTE METAL ASSEMBLY	77	6795242	NYLON RIVET
62	6761962	LAMP HOLDER	78	0678312	DT SCREW-2.6MMDX12MM (BLACK)
63	3248854	FRONT PANEL ASSEMBLY (U, C, W, FS, AU)	79	8602406	DT FLAT SCREW-3MMDX6MM
63	6225313	FRONT PANEL ASSEMBLY (BS)	80	8699412	BIND TAPPING SCREW-3MMDX12MM (BLACK)
64	3293421	PUSH BUTTON ASSEMBLY (POWER) [U, C, FS, AU]	81	7781581	BT FLAT SCREW-3MMDX10MM
64	3293422	PUSH BUTTON ASSEMBLY (POWER) [W]	82	7781582	FLAT SCREW-3MMDX10MM (BLACK)
64	6768026	PUSH BUTTON ASSEMBLY (POWER) [BS]	83	8698410	BT BIND SCREW-3MMDX10MM (W,FS,BS, AU)
65	6292361	PUSH BUTTON (NORMAL/CrO <sub>2</sub> /METAL)	83	8699410	BT BIND HEAD SCREW-3MMDX10MM (BLACK) [U, C]
66	6292371	PUSH BUTTON (DOLBY NR/DOLBY B/C)	84	0626577	SPECIAL WASHER
67	3292794	PUSH BUTTON ASSEMBLY (INPUT) [U, C, W, FS, AU]	85	8601408	DT FLAT SCREW-3MMDX8MM
67	6055473	PUSH BUTTON ASSEMBLY (INPUT) [BS]	△ 86	5213061	POWER TRANSFORMER (U,C)
68	3292374	EJECT BUTTON ASSEMBLY (U, C, W, FS, AU)	△ 86	5213064	POWER TRANSFORMER (W)
68	6054863	EJECT BUTTON ASSEMBLY (BS)	△ 86	5213062	POWER TRANSFORMER (FS)
69	3292535	SLIDE KNOB (TIMER) [U, C, W, FS, AU]	△ 86	5213063	POWER TRANSFORMER (BS, AU)
69	6291714	SLIDE KNOB (TIMER) [BS]	87	5310491	DIGITAL PEAK METER
70	3292421	KNOB ASSEMBLY (RECORD-R) [U, C, W, FS, AU]	88	5641431	REED RELAY
70	6289373	KNOB ASSEMBLY (RECORD-R) [BS]	89	6771691	LED HOLDER ASSEMBLY

IC501 ( $\mu$ PD554C 081, for mechanism control) PIN FUNCTION TABLE

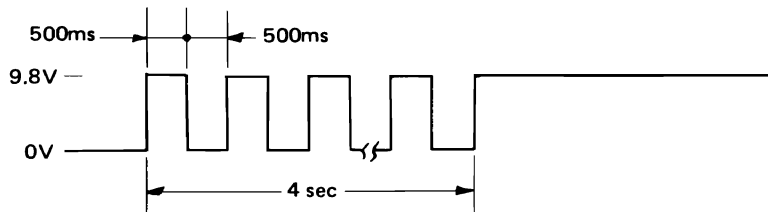
Pin No.	Pin symbol	Function
1	CLOCK <sub>1</sub>	These pins are externally attached to the resonance circuit to operate the built-in clock oscillation circuit which is to be the reference of the microprocessor operation and the oscillation frequency is set to 400 kHz.
28	CLOCK <sub>0</sub>	
2	$\overline{\text{FF}}$	FF mode input pin. Judged to be the FF mode with Lo potential input.
3	$\overline{\text{STOP}}$	Stop mode input pin. Judged to be the STOP mode with the Lo potential input.
4	$\overline{\text{REC}}$	REC mode input pin. Judged to be the REC mode with the Lo potential input.
5	$\overline{\text{PAUSE}}$	PAUSE mode input pin. Judged to be the PAUSE mode with the Lo potential input.
6	$\overline{\text{REC MUTE}}$	REC MUTE input pin. Judged to be the REC MUTE mode when Lo potential is input during REC or REC/PAUSE mode.
7	PLAY SIGNAL	PLAY signal output pin. Outputs the pulse with approx. 50 ms width during transfer to play mode or REC mode, and sets the PLAY mode input pin (24) to the Lo potential input.
8	PAUSE SIGNAL	• PAUSE signal output pin. Connected to Vss pin because this is not used. • tial during other modes.
9	REWIND SOL.	• Rewind solenoid drive control output pin. Outputs Hi potential during REC, PLAY, REW. When the mode is changed over in the FF mode, Hi potential is output after the inhibit time (700 ms). • Test program judgement input pin. When it is connected to Vss pin (pin (14)) and power is turned ON, it is judged and the test program is being executed.
10	FF SOL.	• FF solenoid drive control output pin. Outputs Hi potential during REC, PLAY, FF. When the mode is changed over in the REW mode, Hi potential is output after the inhibit time (700 ms).
11	PAUSE INDI.	<p>Pause indicator output pin. Hi potential is output during pause and the pause indicator lights.</p> <p>The flashing pulse is output at intervals of 1 sec during AUTO REC MUTE, and normal Hi potential is output after a 4 sec elapse of AUTO REC MUTE.</p>  <p style="text-align: center;">(During AUTO REC MUTE)</p>
12	RECORD INDI.	<p>• REC indicator output pin. Hi potential is output during REC, REC PAUSE and REC HOLD. Hi potential is output after the inhibit time (60ms) when the mode is changed in the PLAY mode, and Hi potential is output after the inhibit time (760ms) when the mode is changed in the FF or REW mode.</p> <p>• When the REC and PLAY buttons are pressed simultaneously or the timer switch is set to "REC" within 4 sec after the power is supplied and resetting is complete, Hi potential is output after resetting.</p>

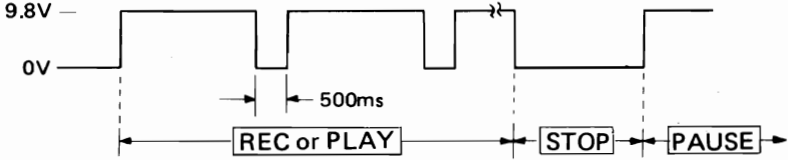
Pin No.	Pin symbol	Function
13	PLAY INDI.	<ul style="list-style-type: none"> <li>• Play indicator output pin. The light-off pulse (500ms) is output while synchronizing with the tape end detector pulse during REC and PLAY, and Hi potential is output during pause.</li> <li>• When the REC and PLAY buttons are pressed simultaneously or the timer switch is set to "REC" within 4 sec after the power is supplied and resetting is complete, the flashing pulse is output at intervals of 600ms for 4 sec after resetting is complete, and normal Hi potential is output after this.</li> </ul> 
14	V <sub>SS</sub>	Hi side power pin. Applies +10V.
15	TEST	Microprocessor TEST pin. Connected to V <sub>SS</sub> pin because this is not used.
16	REC MUTE	REC amp muting control output pin. Outputs Hi potential after the inhibit time (450ms) during REC. When the mode is changed in FF and REW, the inhibit time is 1.1 sec, and Lo potential is output in general.
17	LINE MUTE	Line amp final stage muting control output pin. Outputs Hi potential after elapse of the inhibit time (450ms) during REC, REC HOLD, REC PAUSE and PLAY. When the mode is changed in the FF and REW modes, the inhibit time is 1.1 sec and Lo potential is output in general.
18	BIAS	Output pin to operate the bias oscillation circuit during REC mode. Outputs Lo potential in general and outputs Hi potential after the inhibit time (120ms) during the REC mode. When the mode is changed in the FF and REW modes, the inhibit time is 820ms.
19	REC INV.	REC indicator inversion output pin. Blank pin because this is not used.
20	TIMER	Timer REC/PLAY detector signal output pin. Outputs Lo potential until 1 cycle of the main program is completed via the inhibit time (4s) after power is supplied, and feeds back to the REC input or PLAY input pin via the timer switch to judge the timer REC/PLAY function. Returns to Hi potential output after 1 cycle (approx. 4ms) of the main program is completed.
21	A.R.S.	Auto rewind stop input pin. Connected to V <sub>SS</sub> pin because this is not used.
22	A.R.P.	Auto rewind play input pin. Connected to V <sub>SS</sub> pin because this is not used.
23	REW	REW mode input pin. Judged to be the rewind mode with Lo potential input.
24	PLAY	PLAY mode input pin. Judged to be the play mode with Lo potential input.
25	REEL PULSE	<ul style="list-style-type: none"> <li>• Tape end detector reel pulse input pin. When the take-up reel disc stops turning, the pulse output is not present, and tape end detection judgement is done with no pulse input (Negative edge) for 3 sec or more during record and play, and for 1 sec or more during FF and REW modes.</li> <li>• Tape count when the memory rewind function is operating is done by counting the pulses input.</li> </ul>
26	RESET	Reset pin. Set this pin Hi to Lo potential to perform initial resetting when power is supplied.
27	V <sub>GG</sub>	Power pin. Connected to GND.

SYMBOL-NO	P-NO	DESCRIPTION	SYMBOL-NO	P-NO	DESCRIPTION
MISCELLANEOUS			PL301	5762035	LAMP (DOLBY C INDICATOR)
△	5746342	POWER CORD (BS)	PL502	5762035	LAMP (CASSETTE ILLUMINATION)
△	5746443	POWER CORD (U,C)	△ S 1	5633842	PUSH SWITCH (POWER) [U, C]
△	5746571	POWER CORD (AU)	△ S 1	5633843	PUSH SWITCH (POWER) [FS, BS, AU, W]
△	5746661	POWER CORD (W,FS)	S 2	5634437	PUSH SWITCH (TAPE, DOLBY NR, DOLBY B/C)
△ F 1	5720178	FUSE 250MA (W)	S 3	5634363	PUSH SWITCH (INPUT)
△ F601	5721061	FUSE 1.6A (W,FS,BS,AU)	S 4	5624131	SLIDE SWITCH (TIMER)
△ F601	5721161	FUSE 1.6A (U,C)	△ S 13	5605083	ROTARY SWITCH (VOLTAGE SELECTOR) [W]
△ F602	5720179	FUSE 1A (W,FS,BS,AU)	S501-507	5633771	PUSH SWITCH (REW, PLAY, FF, STOP, REC, PAUSE, MUTE)
△ F602	5721164	FUSE 1A (U,C)	FOR ACCESSORIES		
JK1	5679823	JACK (MIC, HEADPHONE)	7740321	5894163	HEAD CLEANING STICK
JK5	5677131	8P DIN SOCKET (REMOTE)		5894163	PATCH CORD
JK7	5676261	PIN JACK ASSEMBLY (LINE IN, LINE OUT)	△	5652291	SOCKET ADAPTER (W)
PL501	5765071	LAMP (METER ILLUMINATION)			



**HITACHI SALES CORPORATION OF AMERICA****Eastern Regional Office**

1200 Wall Street West, Lyndhurst, New Jersey 07071

Tel. 201-935-8980

**Mid-Western Regional Office**

1400 Morse Ave., Elk Grove Village, Ill. 60007

Tel. 312-593-1550

**Southern Regional Office**

510 Plaza Drive College Park, Georgia 30349

Tel. 404-763-0360

**Western Regional Office**

401 West Artesia Boulevard, Compton, California 90220

Tel. 213-537-8383

**HITACHI SALES CORPORATION OF HAWAII, INC**

3219 Koapaka Street, Honolulu, Hawaii 96819, U.S.A.

Tel. 808-836-3621

**HITACHI (HSC) CANADA INC.**

3300 Trans Canada Highway Pointe Claire, Quebec, H9R1B1, Canada

Tel. 514-697-9150

**HITACHI SALES EUROPA GmbH**

2 Hamburg 54, Kleine Bahnstraße 8, West Germany

Tel. 850 60 71-75

**HITACHI SALES (U.K.) Ltd.**

Hitachi House, Station Road, Hayes, Middlesex UB3 4DR, England

Tel. 01-848-8787

**HITACHI SALES SCANDINAVIA AB**

Rissneleden 8, Sundbyberg, Box 7138, S-172-07 Sundbyberg 7,

Sweden

Tel. 08-98 52 80

**HITACHI SALES NORWAY A/S**

Orebekk 1620 Gressvik P.O. Box 46 N-1601 Fredrikstad, Norway

Tel. 032-28050

**SUOMEN HITACHI OY**

Box 151, SF-15100 Lahti 10, Finland

Tel. Lahti 44 241

**HITACHI SALES A/S**

Kuldysen 13, DK-2630 Taastrup, Denmark

Tel. 02-999200

**HITACHI SALES A.G.**

5600 Lenzburg, Switzerland

Tel. 064-513621

**HITACHI-FRANCE (Radio-Télévision Electro-Ménager) S.A.**

9, Boulevard Ney 75018, Paris, France

Tel. 201-25-00

**HITACHI SALES WARENHANDELS GMBH**

A-1180/Wien, Kreuzgasse 27

Tel. (0043222) 439367/8

**HITACHI SALES AUSTRALIA Pty Ltd.**

153 Keys Road, Moorabbin, Victoria 3189 Australia

Tel. 95-8722

**HITACHI Ltd. TOKYO JAPAN**

Head Office : THE HITACHI ATAGO BLDG.

No. 15-12, 2-Chome Nishi-Shinbashi

Minato-Ku, Tokyo 105, Japan

Tel. Tokyo (03) 502-2111