

SERVICE MANUAL

English

No. 1355

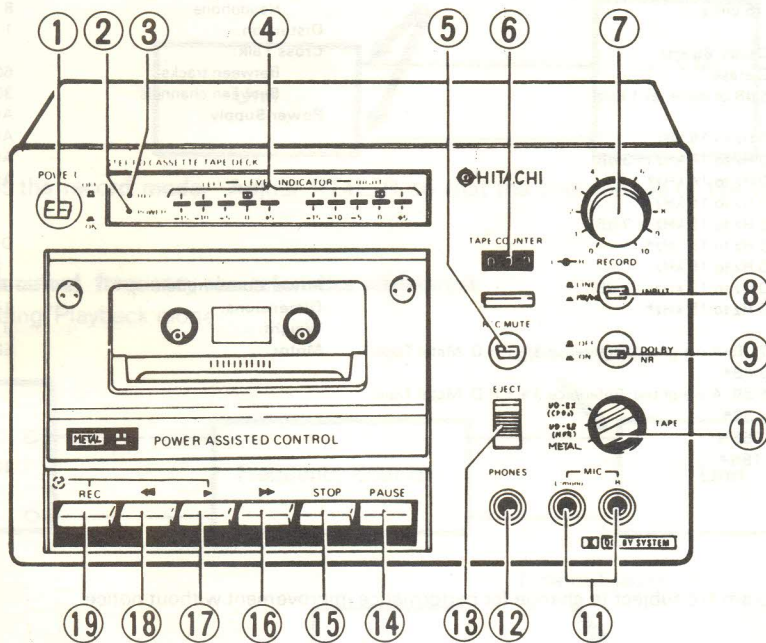

KEY TO ILLUSTRATIONS

- | | |
|----------------------------|-------------------------------------|
| ① POWER (MAINS) SWITCH | ⑪ MICROPHONE SOCKETS (L/mono and R) |
| ② POWER INDICATOR | ⑫ HEADPHONE SOCKET |
| ③ RECORDING INDICATOR | ⑬ EJECT BUTTON |
| ④ LEVEL INDICATORS | ⑭ PAUSE BUTTON |
| ⑤ REC. MUTE SWITCH | ⑮ STOP BUTTON |
| ⑥ TAPE COUNTER | ⑯ FAST FORWARD BUTTON |
| ⑦ RECORDING LEVEL CONTROLS | ⑰ PLAYBACK BUTTON |
| ⑧ INPUT SELECTOR | ⑱ REWIND BUTTON |
| ⑨ DOLBY NR SWITCH | |
| ⑩ TAPE SELECT SWITCH | |

SAFETY PRECAUTION

The following precautions should be observed when servicing.

1. Since many parts in the unit have special safety related characteristics, always use genuine Hitachi's replacement parts. Especially critical parts in the power circuit block should not be replaced with other makes. Critical parts are marked with \triangle in the schematic diagram and circuit board diagram.
2. Before returning a repaired unit to the customer, the service technician must thoroughly test the unit to ascertain that it is completely safe to operate without danger of electrical shock.

STEREO CASSETTE TAPE DECK

April 1980

D-M1 MKII / D-M2 MKII

SPECIFICATIONS

Semi-conductors:			
Module:	1	Input Sensitivity and Impedance:	
IC's:	5	Microphone:	0.35mV, 300 ohms to 5 kohms
Transistors:	6[D-M1 (U, C)] 7[D-M1 (W)/D-M2 (FS, BS, AU, W)]	Line in:	60mV, 50 kohms or more
Diodes:	10[D-M1 (U, C)] 11[D-M2 (FS, BS, AU, W)] 12[D-M1 (W)]	DIN (Record/Playback):	0.35mV, 3.3 kohms [D-M1 (W)/D-M2 (FS, BS, AU, W)] 500mV or more
LED's:	12	Output Level:	
Track System:	4 track 2 channel	Output Load Impedance:	
Tape:	Cassette tape (C-30, 60, 90)	Line out:	50 kohms or more
Tape Speed:	4.75 cm/s	DIN (Record/Playback):	500mV [D-M1 (W)/D-M2 (FS, BS, AU, W)]
Recording System and Bias		Headphone:	8 ohms to 2 kohms
Frequency:	AC bias, 85 kHz	Distortion:	1.5% (1 kHz 0 VU)
Erasing System:	AC erase	Cross Talk:	
Erase Ratio:	65 dB or more (at 1 kHz)	Between tracks:	60 dB (at 1 kHz) or more
Frequency Response:		Between channels:	30 dB (at 1 kHz) or more
UD-ER (NOR)	30 Hz to 15 kHz 30 Hz to 14 kHz (± 3 dB) 30 Hz to 14 kHz*	Power Supply:	AC 120V, 60 Hz [D-M1 (U, C)] AC 220V, 50 Hz [D-M2 (FS)] AC 240V, 50 Hz [D-M2 (BS, AU)] AC 100 to 120V, 200 to 240V, 50/60 Hz [D-M1 (W)/D-M2 (W)]
UD-EX (CrO ₂)	30 Hz to 16 kHz 30 Hz to 15 kHz (± 3 dB) 30 Hz to 15 kHz*	DC12V (Use car battery adaptor)	[D-M1 (U, C, W)]
Metal	30 Hz to 16 kHz 30 Hz to 15 kHz (± 3 dB) 30 Hz to 15 kHz*	Power Consumption:	9.5W
S/N (Signal to Noise Ratio):		Dimensions:	146(H) x 230(W) x 162(D) mm
Dolby NR OFF:	57 dB (A weighted, Reference 3% T.H.D. Metal Tape) 57 dB*	Weight:	3.5 kg
Dolby NR ON:	65 dB (A weighted, Reference 3% T.H.D. Metal Tape) 64 dB*	Motor:	Electronically controlled motor
Wow and Flutter:	0.055% 0.18%*		

* According to DIN 45 500

Specifications and Schematic diagram are subject to change for performance improvement without notice.

DISASSEMBLY

1. Cassette lid

- 1) Pressing the eject button opens the cassette cover.

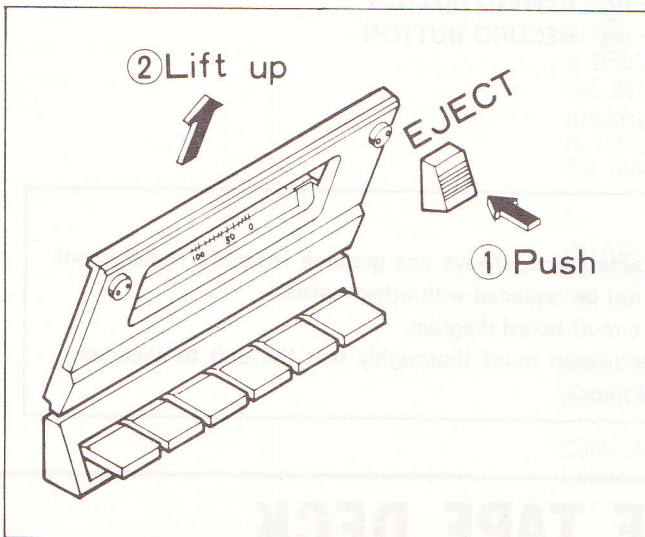

2. Top case

- 1) 4 screws

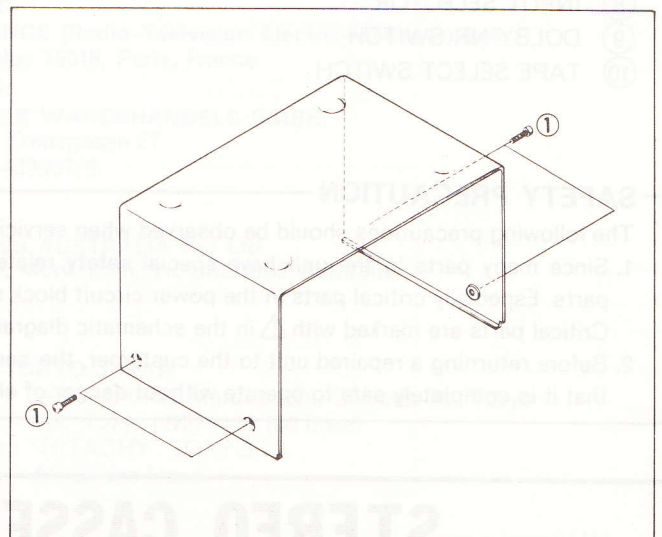

3. Front panel

- 1) Cassette lid (See item 1)
- 2) Top case (See item 2)
- 3) Remove the REC LEVEL button and TAPE selector button.
- 4) (2-1) 2 screws
- 5) (2-2) 3 screws

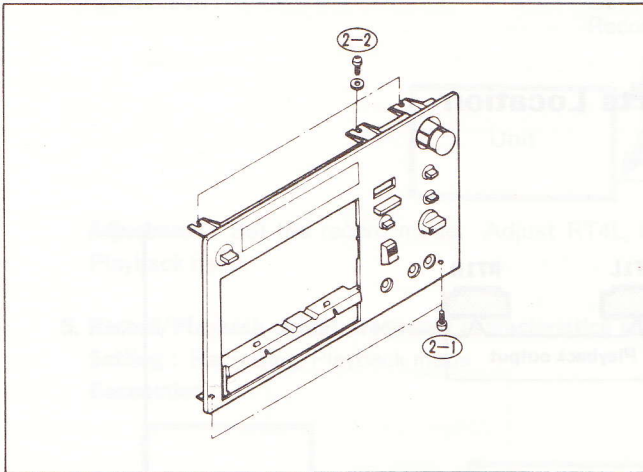

4. Main PC board

- 1) Front panel (See item 3)
- 2) (3-1) 1 screw
- 3) (3-2) 1 screw

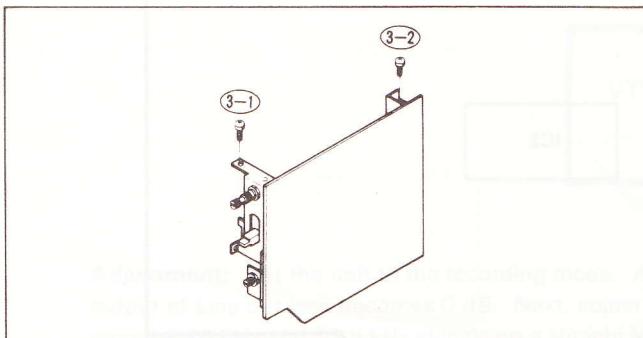

5. Cassette chassis

- 1) Main PC board (See item 4)
- 2) (4-1) 1 screw
- 3) (4-2) 2 screws
- 4) (4-3) 2 screws

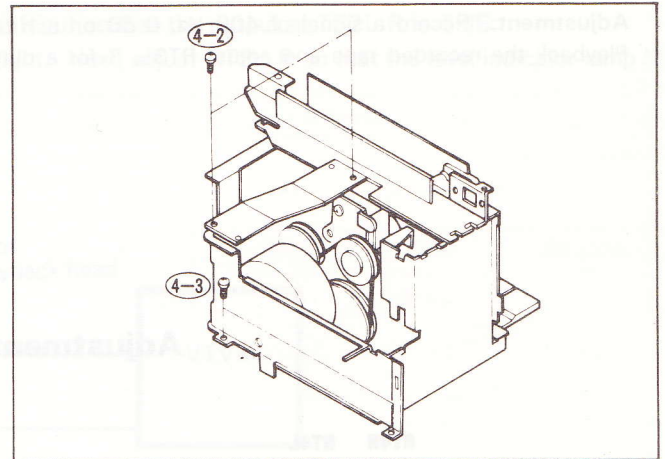
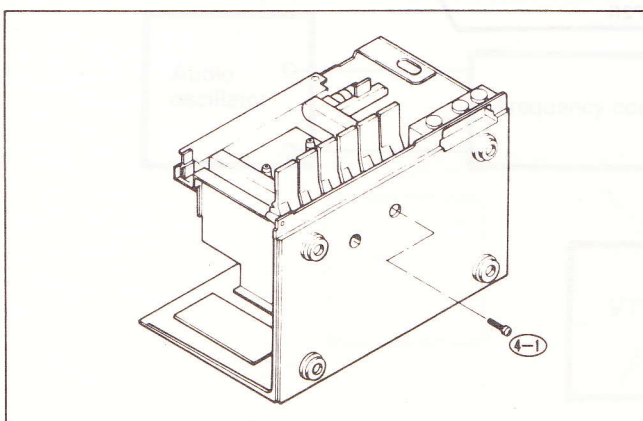

6. Power PC board [D-M1 (U, C, W)]

- 1) Cassette chassis (See item 5)
- 2) (5-1) 2 screws
- 3) (5-2) 1 screw

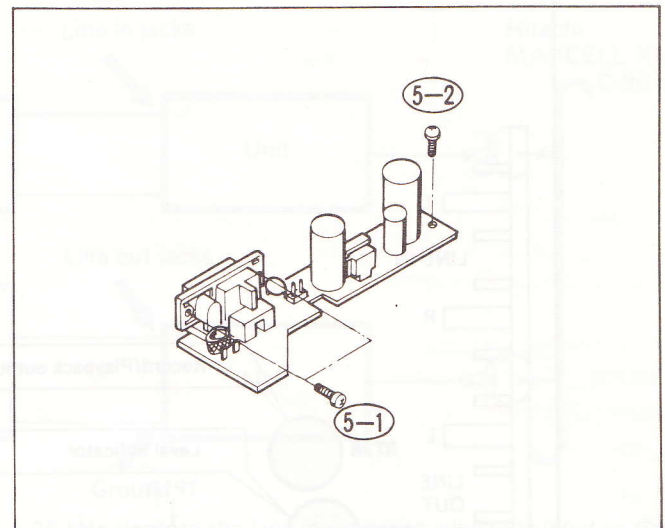

6-1. Power PC board [D-M2 (FS, BS, AU, W)]

- 1) Cassette chassis (See item 5)
- 2) (5-1) 1 screw
- 3) (5-2) 1 screw

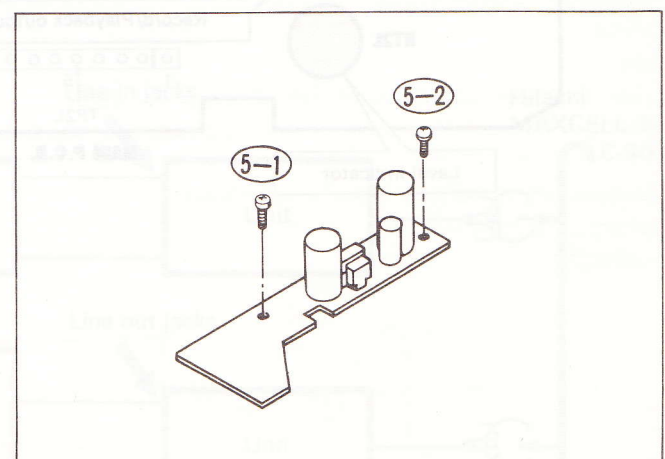

ADJUSTMENT

Perform the following adjustments in the sequence stated after cleaning the head, pressure roller, and capstan with a head cleaning stick moistened in alcohol. Also, unless specially indicated otherwise, set the switches and controls to the positions indicated in the table.

Symbol No.	Switches and Control	Position	Symbol No.	Switches and Control	Position
S2	Input switch	LINE	S3	Dolby NR switch	OFF
S5	Tape selector switch	UD-ER (Normal)	RV1L, R	Record level controls	Maximum
S8	Rec mute switch	OFF			

1. Tape speed adjustment

Setting : Playback mode

Connection :

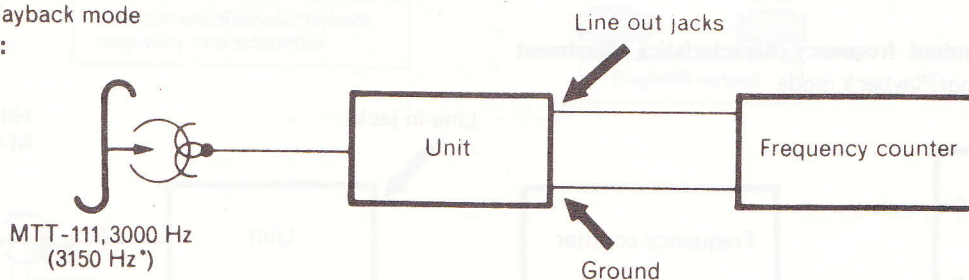

Adjustment : Warm up the unit for approximately 20 minutes ; then playback test tape MTT-111, 3000 Hz (3150 Hz*), a reading of 3030 ± 10 Hz (3150 Hz *). Carry out the measurement at the middle of the tape.

* According to DIN 45 500.

2. Head azimuth adjustment

Setting : Playback mode

Connection :

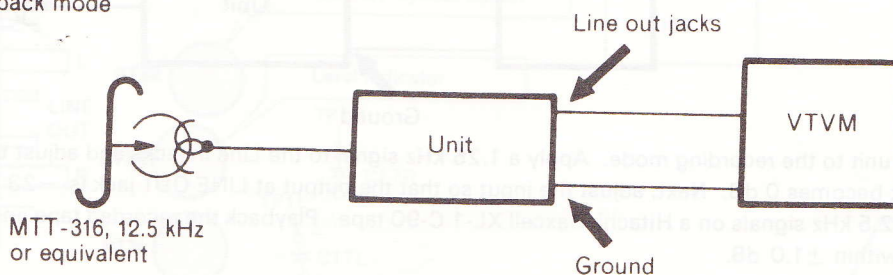

Adjustment : Playback a test tape (MTT-316, 12.5 kHz or equivalent) and adjust the azimuth adjustment screw for maximum output.

Note :

When the maximum values of both channels are different, tune to the maximum value of the L channel. In this case, the difference between the maximum values of both channels should be 2 dB.

3. Playback output and level indicator adjustment

Setting : Playback mode

Connection :

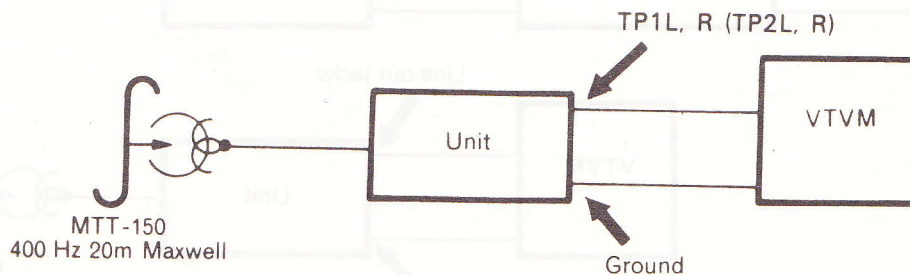

Adjustment : Playback a Dolby calibration tape (MTT-150, 400 Hz 20m Maxwell) and adjust RT1L, R so that the voltage of TP1L, R becomes 0.775V.

D-M1 MKII / D-M2 MKII

Next, apply a 1 kHz signal to the LINE IN jacks and adjust the input so that the output at TP2L, R is 0 dB.

Then, adjust RT2L, R so that the level indicator lamp (0 dB) light. Next, adjust RT2L, R so that the level indicator lamp (0 dB) goes off when the output of the TP2L, R is -1 dB.

4. Bias current adjustment

Setting : Recording mode

Connection :

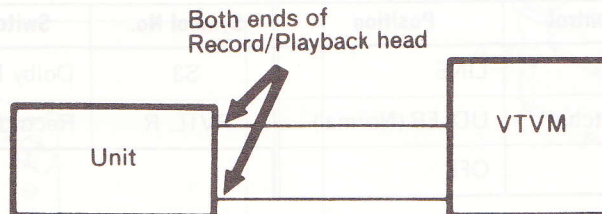

Adjustment : Set the record mode. Adjust RT4L, R so that the bias voltage of 15V is applied to the both ends of Record/Playback head.

5. Record/Playback output frequency characteristics adjustment

Setting : Recording/Playback mode

Connection :

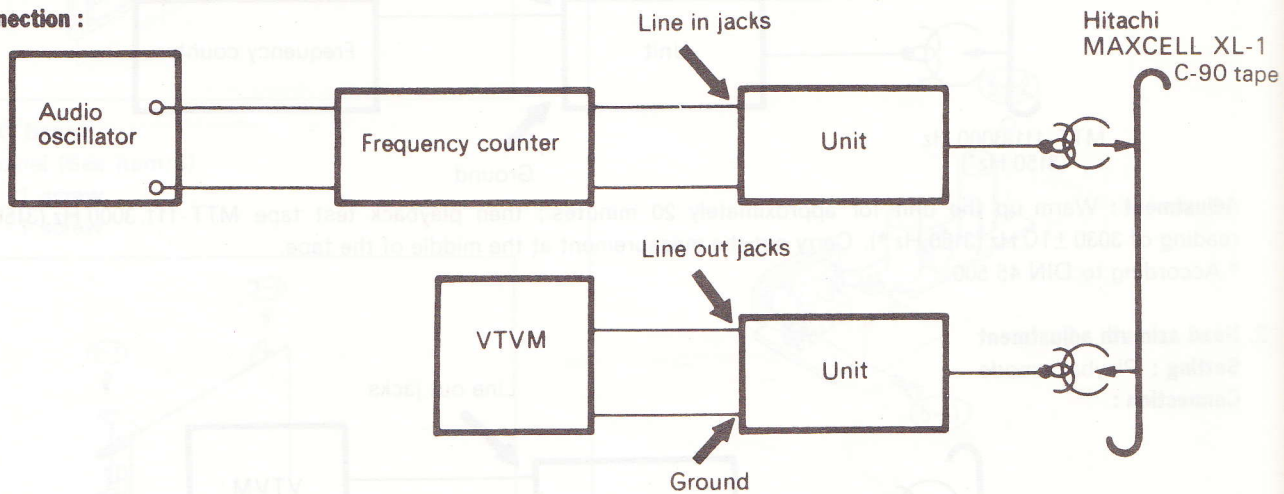

Adjustment : Set the unit to the recording mode. Apply a 1.25 kHz signal to the Line in jacks and adjust the input so that the output of Line out jack becomes 0 dB. Next, adjust the input so that the output at LINE OUT jack is -23 dBm (55mV). And, record 1.25 kHz and 12.5 kHz signals on a Hitachi Maxcell XL-1 C-90 tape. Playback the recorded tape and adjust RT4L, R for an output difference within ± 1.0 dB.

6. Record/Playback output adjustment

Setting : Recording/Playback mode

Connection :

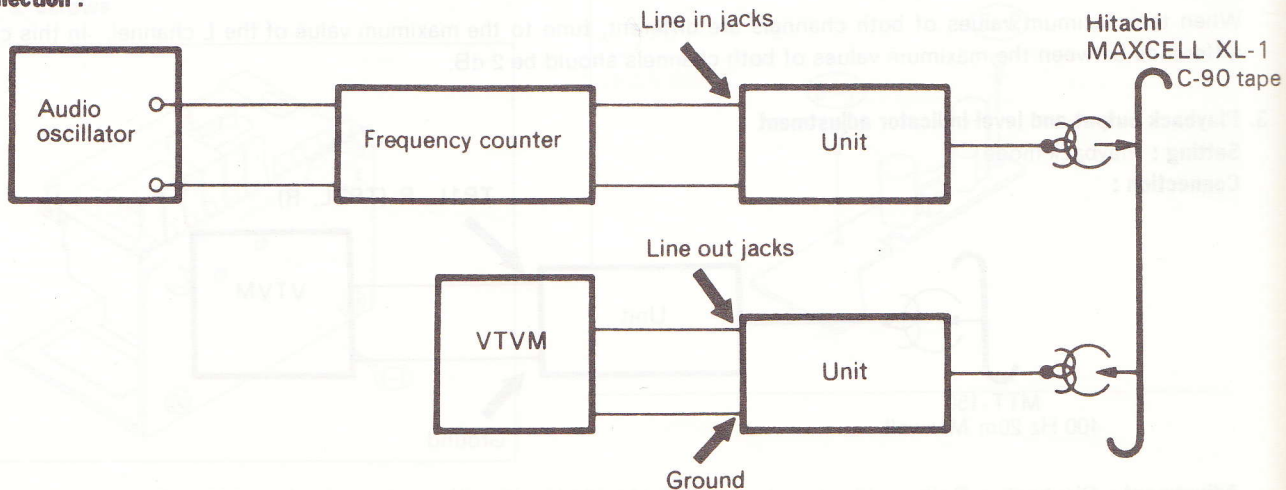

Adjustment: Record a signal of 400 Hz, 0 dB on a Hitachi Maxcell XL-1 C-90 tape.
 Playback the recorded tape and adjust RT3L, R for a playback output of 0 dB \pm 0.5 dB.

Adjustment Parts Location

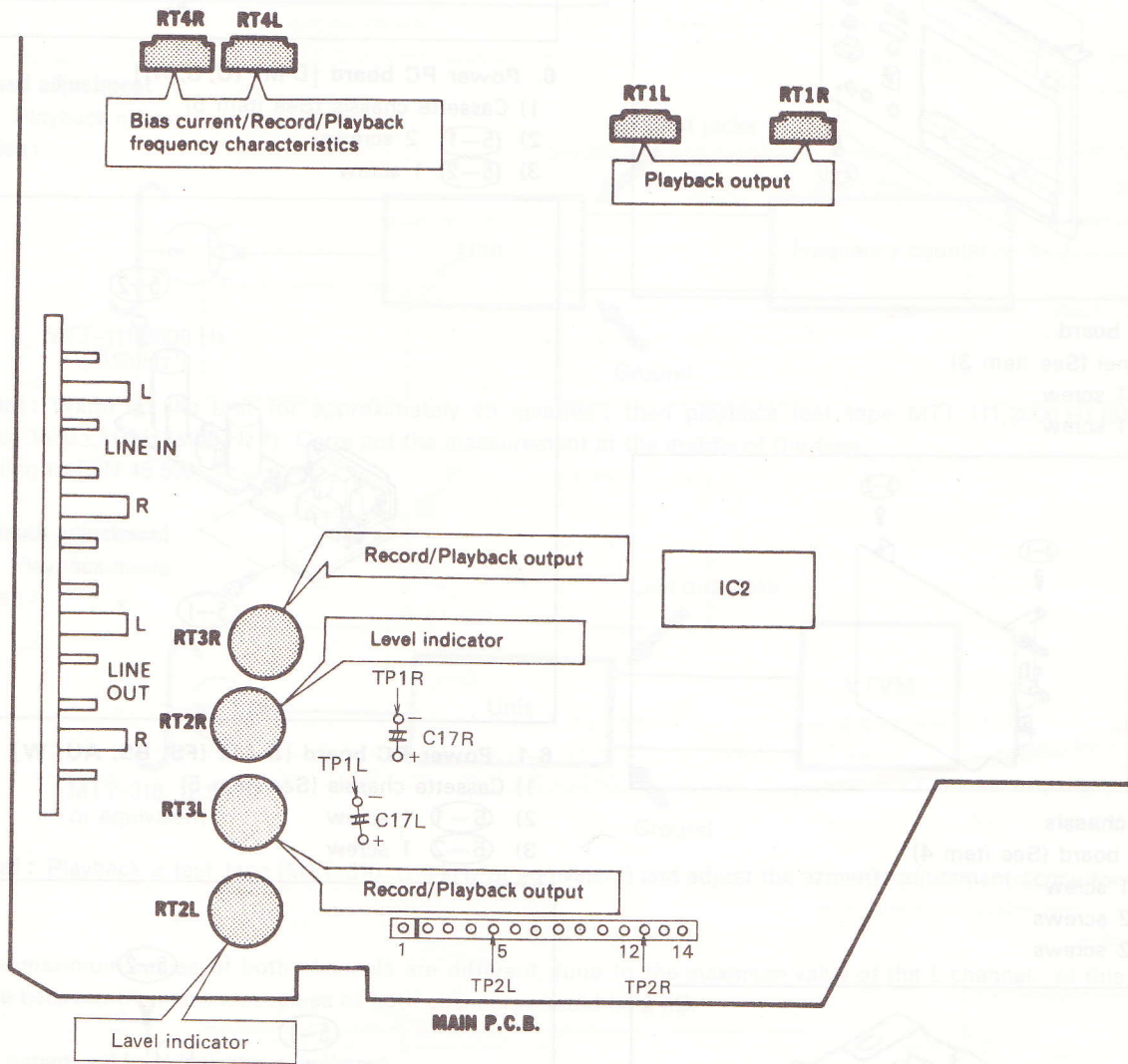

INSPECTION OF MECHANISM

	Check item	Reference value	Remarks	
1	Pressure of pressure roller	350±50gr	Note 1	
2	Pressure of take-up roller	120 to 180gr	Note 2	
3	Torque	Take-up	35 to 60gr-cm	Measure in playback mode
		FF	70 to 120gr-cm	Measure in Fast Forward mode
		Rewind	70 to 120gr-cm	Measure in Rewind mode
4	Back tension	Take-up side	Less than 6gr-cm	—
		Supply side	1 to 3gr-cm	—
5	Brake torque	More than 15gr-cm	—	
6	Flywheel thrust gap	0.05 to 0.5mm	—	

Note 1. Pressure of pressure roller

Set this unit in the playback mode and press the pressure roller in the direction of the arrow using a fan type tension gauge, and measure the pressure when the pressure roller is released from capstan.

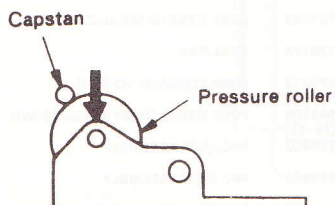

Note 2. Pressure of take-up roller

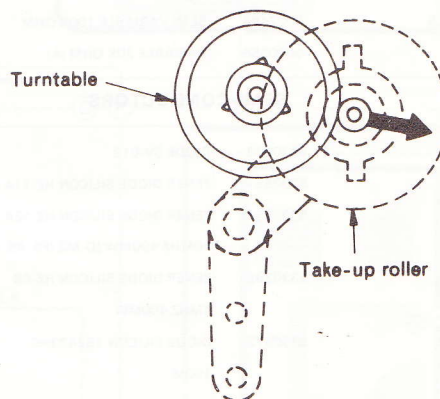

LUBRICATION

Lubricate one or two drops of machine oil to rotating point or lubricate grease to sliding point. Lubricate the respective parts listed below once every 1000 hours or once a year under normal conditions of use. Avoid oiling them excessively, or rotation may become irregular because of oil splashes.

Lubrication	Oil or grease
Motor shaft bearing	Oil
Capstan shaft bearing	
Pressure roller bearing	

REPLACEMENT PARTS LIST

SYMBOL-NO	P-NO	DESCRIPTION	SYMBOL-NO	P-NO	DESCRIPTION
CAPACITORS			TRANSFORMERS		
C3LR	0209005	CERAMIC DISC (RESISTOR SHAPE) 390PF ± 10%	△ T1	5211356	POWER [D-M1 (U)]
C5LR	0209006	CERAMIC DISC (RESISTOR SHAPE) 470PF ± 10%	△ T1	5211932	POWER 400G 8.2VA [D-M2 (BS, AU)]
C6LR	0209002	CERAMIC DISC (RESISTOR SHAPE) 220PF ± 10%	△ T1	5211357	POWER SVA, 300G [D-M1 (C)]
C19LR	0209022	CERAMIC DISC (RESISTOR SHAPE) 2200PF ± 10%	△ T1	5211933	POWER 8VA 400G [D-M2 (FS)]
C20	0209006	CERAMIC DISC (RESISTOR SHAPE) 470PF ± 10%	△ T1	5212056	POWER [D-M1 (W)/D-M2 (W)]
	0209010	CERAMIC DISC (RESISTOR SHAPE) 1000PF ± 10%	COILS		
		[D-M1 (U)]	L1LR	5161664	DOLBY FILTER
C22LR	0209022	CERAMIC DISC (RESISTOR SHAPE) 0.0022MF ± 30%	L2LR	5260215	TRAP 33MH
RESISTORS			L3LR	5120562	BIAS TRAP
R103	0170476	FUSE 47 OHM ± 5% [D-M2 (FS, BS, AU)]	L4	5152087	PEAKING 100MICRO H
	0170482	FUSE 15 OHM ± 5% [D-M1 (U, C, W)]	MISCELLANEOUS		
RT1LR	5007165	SEMI VARIABLE 10K OHM	△	5747214	POWER CORD [D-M1 (W)]
RT2LR	5007186	SEMI VARIABLE 10K OHM	△	5746158	POWER CORD [D-M2 (FS)]
RT3LR	5007186	SEMI VARIABLE 10K OHM	△	5747262	POWER CORD [D-M1 (U, C)]
RT4LR	5007168	SEMI VARIABLE 100K OHM	△	5746541	POWER CORD [D-M2 (BS)]
RV1	5000556	VARIABLE 20K OHM (A)	△	5746312	POWER CORD [D-M2 (W)]
SEMI-CONDUCTORS			△	5746431	POWER CORD [D-M2 (AU)]
D1	5330373	DIODE SV-01B	△	5652121	POWER SOCKET [D-M1 (U, C, W)]
D2	5330551	ZENER DIODE SILICON HZ-11A [D-M1 (U, C, W)]	F1	5721042	FUSE 1.25A [D-M1 (U, C, W)]
	5330531	ZENER DIODE SILICON HZ-12A	F2	5720175	FUSE 0.8A
		10MHZ 400MW [D-M2 (FS, BS, AU, W)]	△ F3	5721012	FUSE 315MA [D-M2 (BS)]
D3	5330392	ZENER DIODE SILICON HZ-6B	△ F3	0591100	FUSE 200MA [D-M1 (W)/D-M2 (W)]
		1MHZ 400MW	J1LR	5679402	MIC JACK ASSEMBLY
D4LR	5330572	DIODE SILICON 1S2473HC	J2	5679402	MIC JACK ASSEMBLY
		100M	J3LR	5676082	PIN JACK
LED5	5380247	LED GL-3PR2	J4LR	5676082	PIN JACK
LED6	5380247	LED GL-3PR2	J5	5653211	DIN JACK [D-M1 (W)/D-M2 (FS, BS, AU, W)]
LED7LR	5380392	LED GL-9PG9	OSC1	5260791	OSCILLATOR BLOCK
LED8LR	5380392	LED GL-9PG9	RL1	5641141	REED RELAY [D-M1 (W)/D-M2 (FS, BS, AU, W)]
LED9LR	5380392	LED GL-9PG9	S1	5623511	SLIDE SWITCH (REC/PLAY)
LED10LR	5380391	LED GL-9PR9	S2	5634271	PUSH SWITCH (INPUT)
LED11LR	5380391	LED GL-9PR9	S3	5634271	PUSH SWITCH (DOLBY NR)
D12	5330573	DIODE SILICON 1S2473 300MHZ 300MW	S4	5633311	PUSH SWITCH (BIAS BEAT)
D13	5330374	DIODE SV-02B	S5	5612293	ROTARY SWITCH (TAPE SELECTOR)
D100	5330572	DIODE SILICON 1S2473HC	S6	5633361	MICRO SWITCH (MUTING)
		100M [D-M1 (W)/D-M2 (FS, BS, AU, W)]	△ S7	5637038	PUSH SWITCH (POWER) [D-M1 (U, C, W)/D-M2 (W)]
D101	5330721	DIODE IN34A-TFI [D-M1 (W)/D-M2 (FS, BS, AU, W)]	△	5633541	PUSH SWITCH (POWER) [D-M2 (FS, BS, AU)]
D102	5331242	DIODE 1SR-34P [D-M1 (U, C, W)]	S8	5623101	SLIDE SWITCH (REC MUTE)
IC1LR	5350963	IC BA340	S9	5633361	MICRO SWITCH (REC)
IC2	5350462	IC HA 11122W	△ S10	5605082	VOLTAGE CHANGE-OVER SWITCH [D-M1 (W)/D-M2 (W)]
IC3LR	5350761	IC SN16880	FOR ACCESSORIES		
M1	5056832	MODULE TA3003D		5895501	PATCH CORD
Q1LR	5321295	TRANSISTOR 2SC1740E		7740321	HEAD CLEANING STICK
Q2LR	5321295	TRANSISOTR 2SC1740E		5660212	SIEMENS PLUG [D-M1 (W)/D-M2 (W)]
Q3	5321301	TRANSISTOR SILICON 2SC1061			
Q10	5320603	TRANSISTOR SILICN 2SA673A-C 80MHZ			
		400MW [D-M1 (W)/D-M2 (FS, BS, AU, W)]			

WIRING DIAGRAM

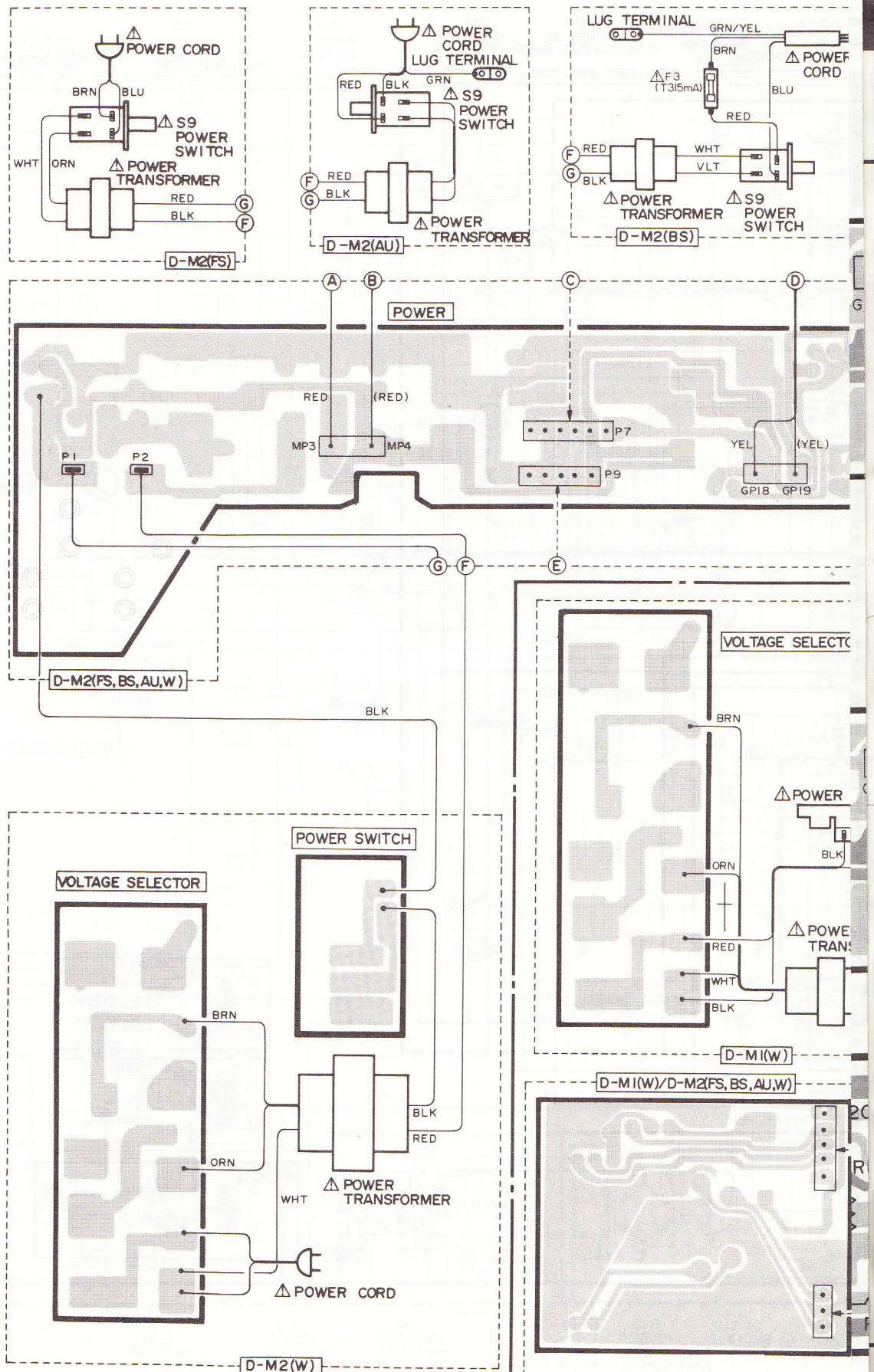

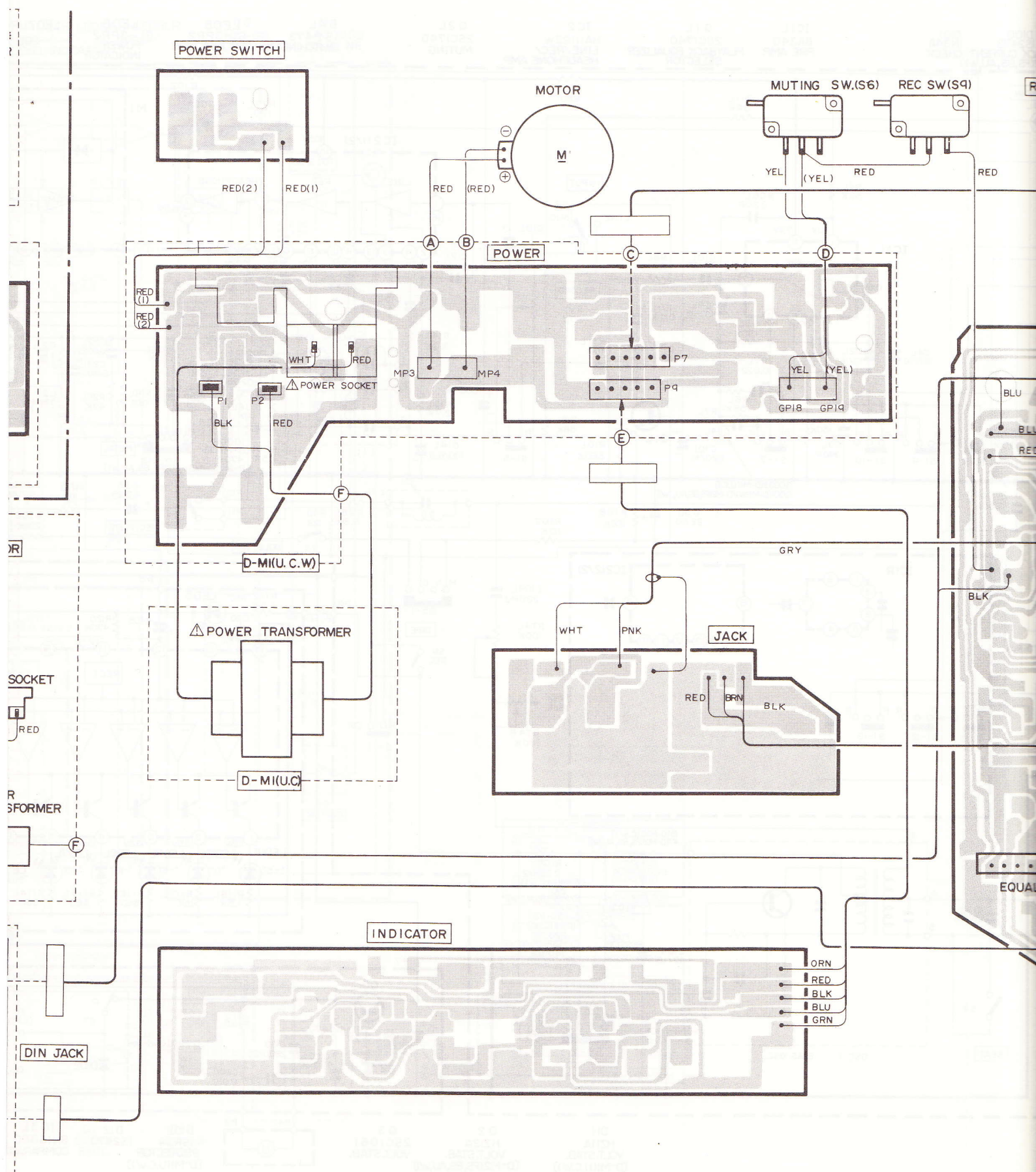

SCHMATIC DIAGRAM

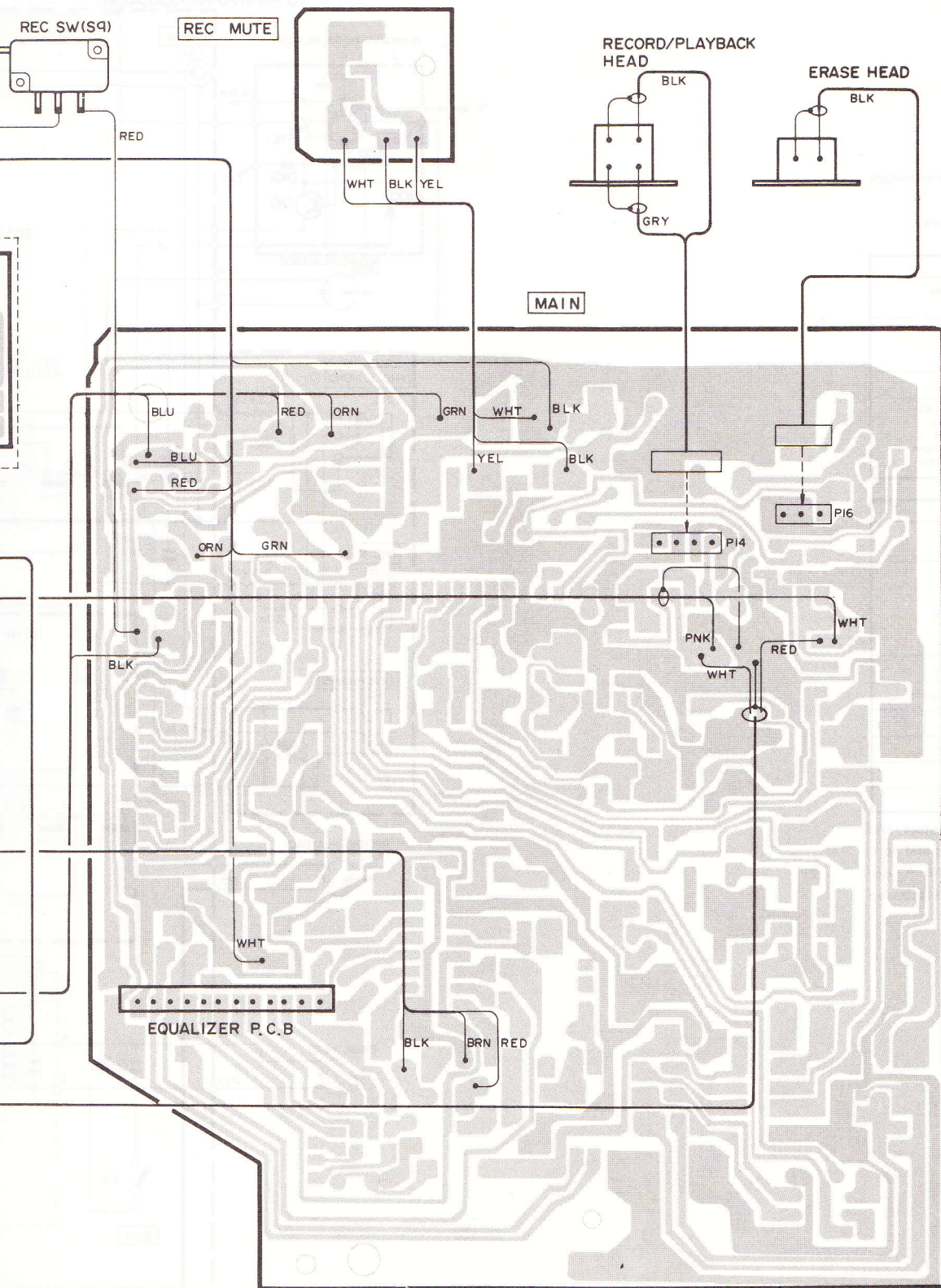





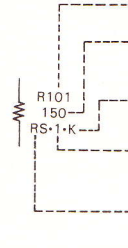

SCHMATIC DIAGRAM

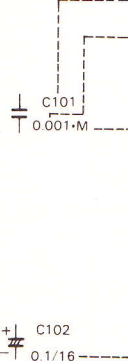
Note:

1. Voltage measured at base of chassis with minimum volume control and no signal.
2. Nomenclature of Resistors and Capacitors.

	Circuit No.	
	Value	No indicated Ω (Ohm) M : 1000 k Ω
	Tolerance	No indicated $\pm 5\%$ K : $\pm 10\%$ M : $\pm 20\%$
	Wattage	No indicated 1/4W
	Sort	No indicated Carbon film RC : Composition RW : Wire wound RS : Oxide metal film RN : Fixed metal film

	Circuit No.		
	Value	No indicated μF P : PF	
	Tolerance	No indicated $\pm 10\%$ J : $\pm 5\%$ M : $\pm 20\%$ Z : $+80\%$, -20% D : ± 0.5 pF C : ± 0.25 pF	
	Sort		Ceramic
			Electrolytic
			Mylar
		Polyster	
		Styrol	
Voltage	No indicated 50WV		

3. Be sure to make your orders of resistors and capacitors with value, voltage, tolerance and sort.
4. When replacing capacitors marked with *, use specified ones stated on parts list since required temperature characteristics.

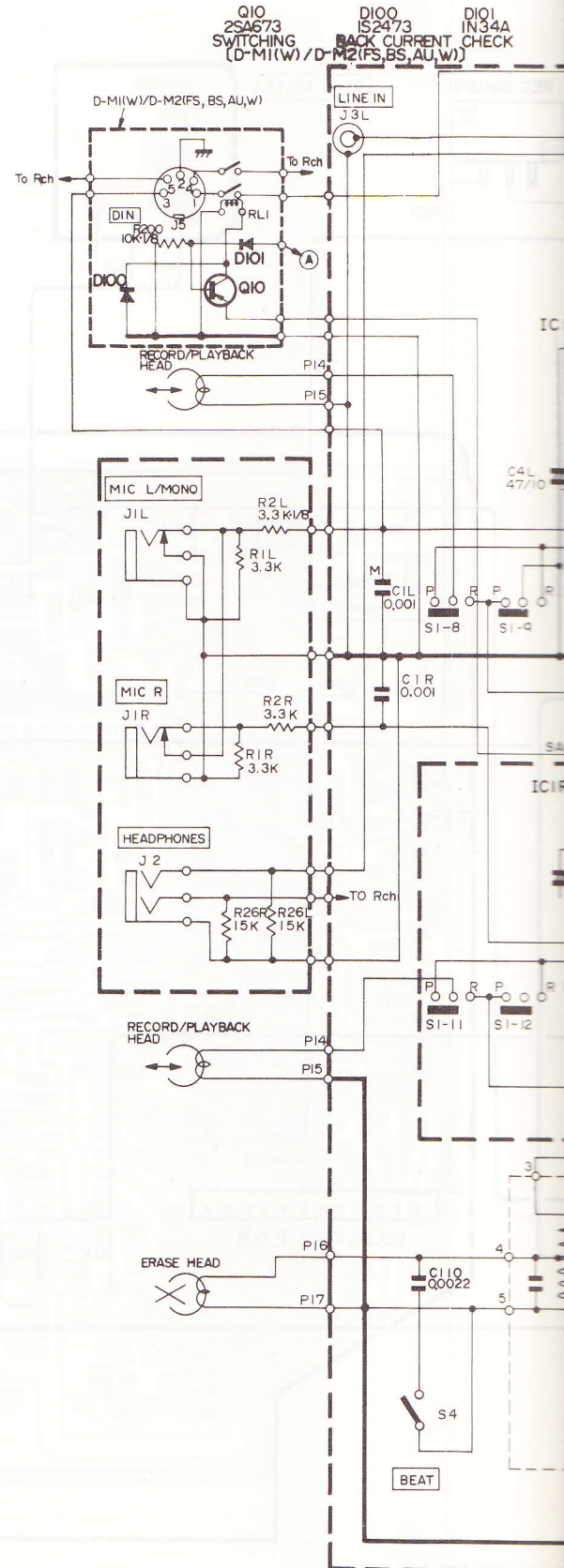

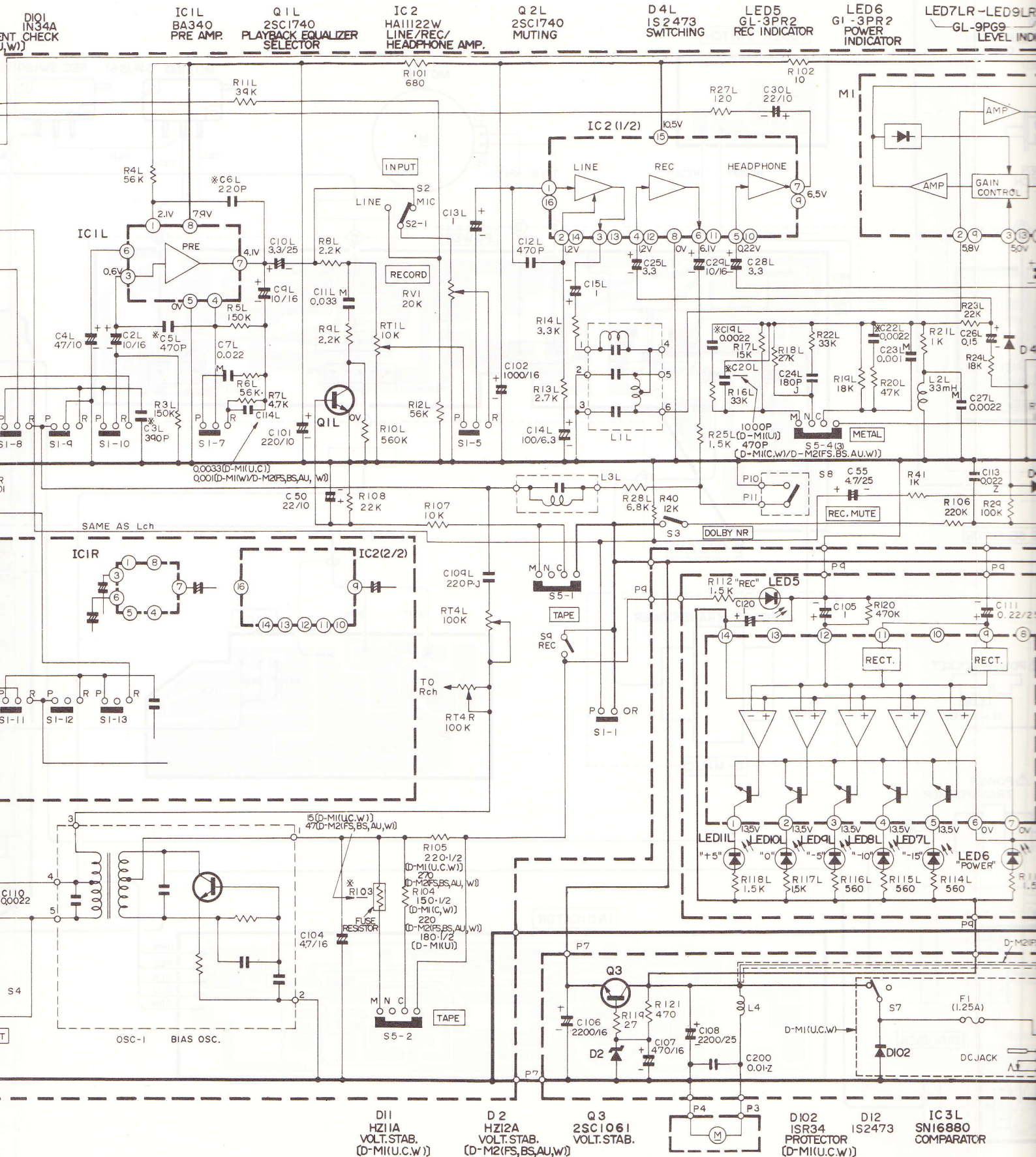

LED7LR-LED9LR LED10LR-LED11LR
 GL-9PG9 GL-9PR9
 LEVEL INDICATOR

D3
 HZ-6B
 LEVEL SHIFT

M1
 TA3003D
 DOLBY NR

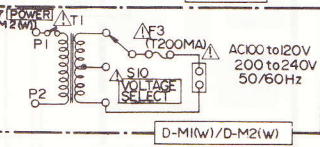
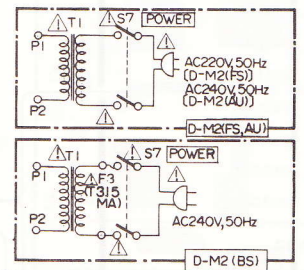
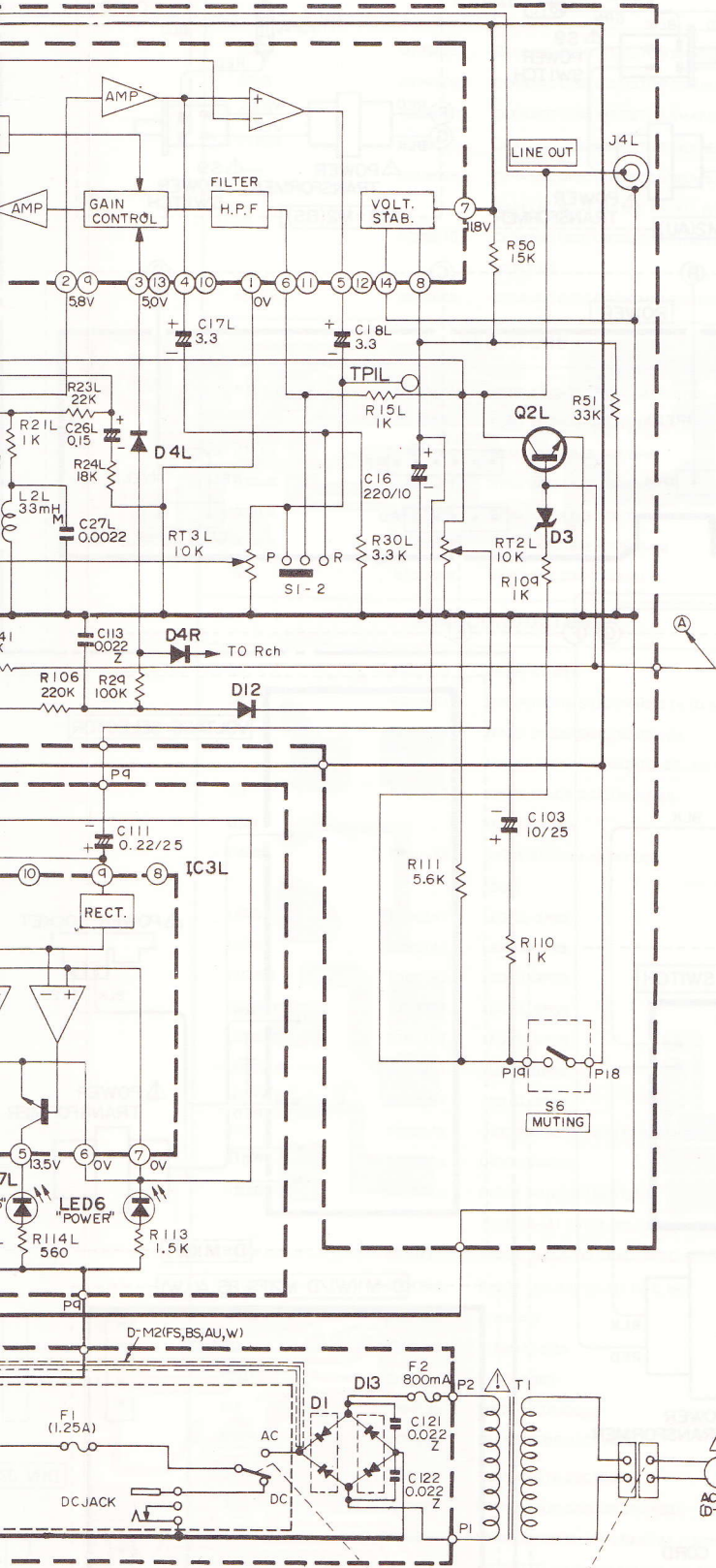

IC3L
 SN16880
 COMPARATOR

D1
 SVO1B
 RECT.

D13
 SVO2B
 RECT.

CIRCUIT BOARD DIAGRAM

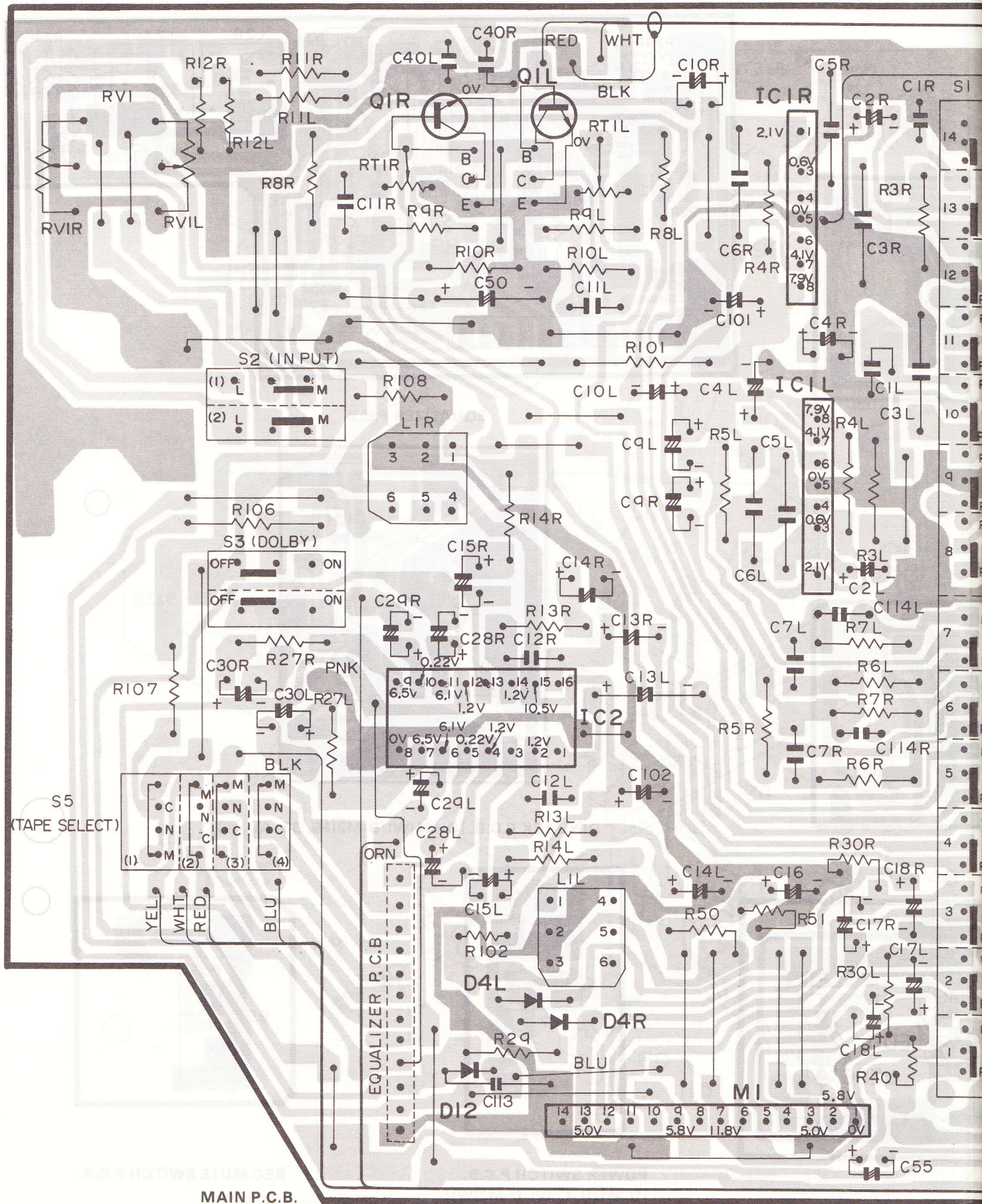

MAIN P.C.B.

■ : Ground ■ : Signal, + B ■ : Component side pattern

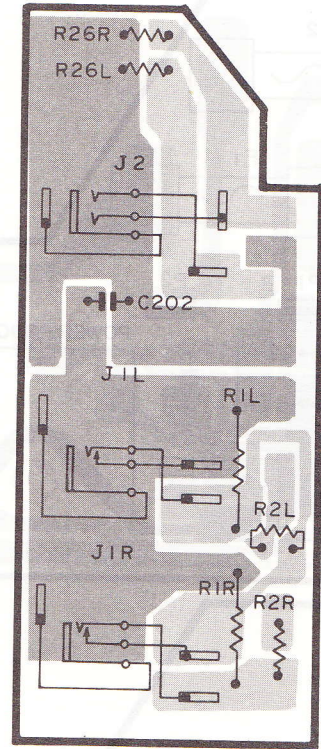
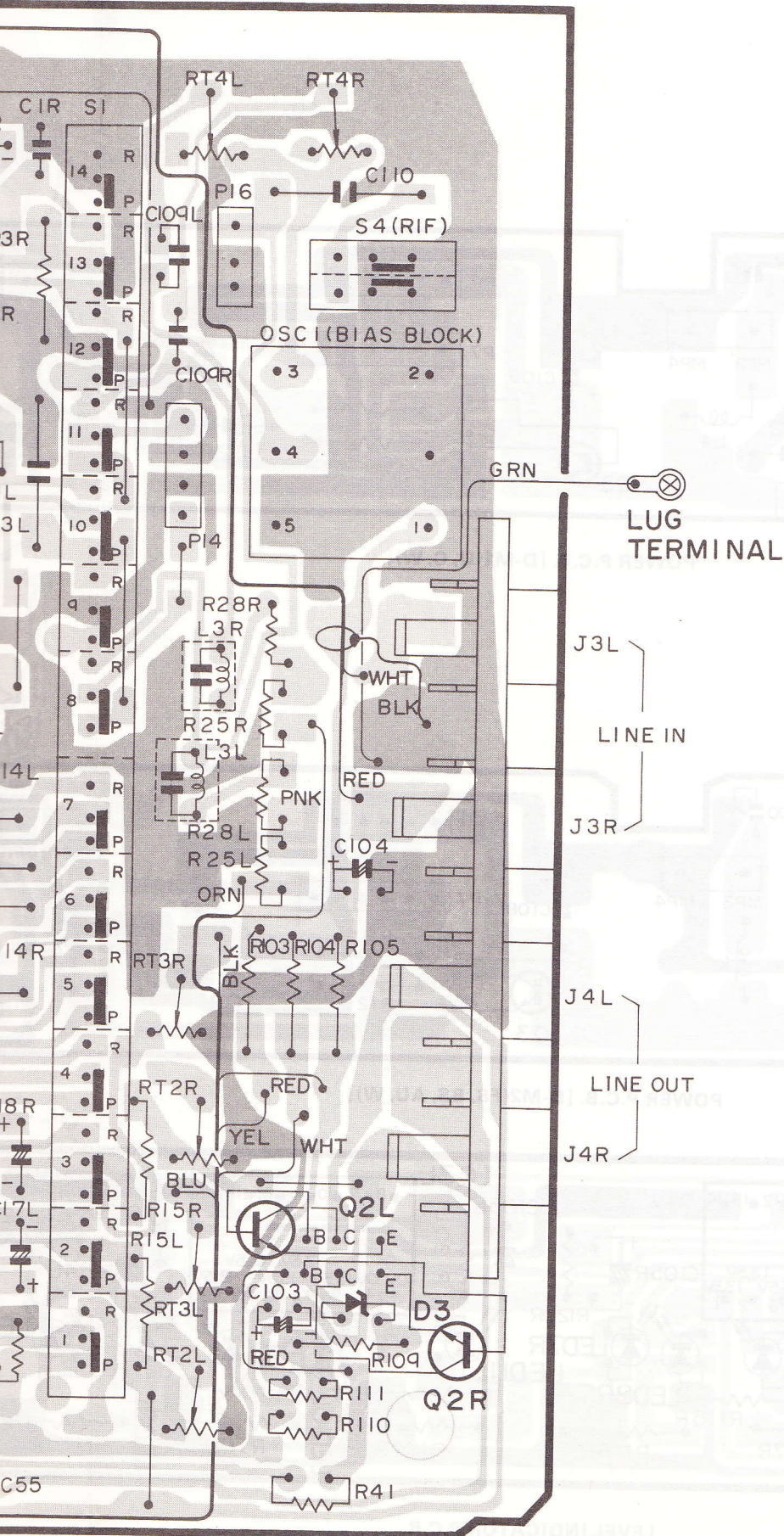

JACK P.C.B.

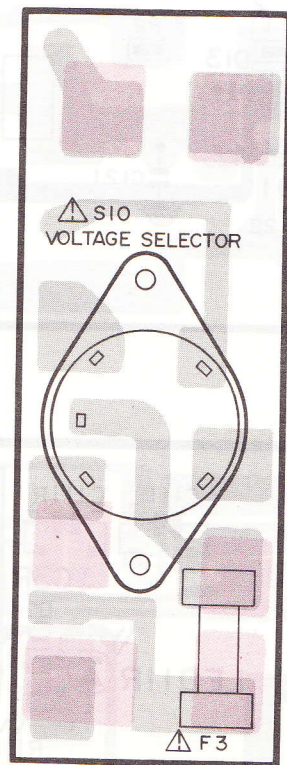

VOLTAGE SELECT SWITCH P.C.B.
[D-M1(W)/D-M2(W)]

CIRCUIT BOARD DIAGRAM

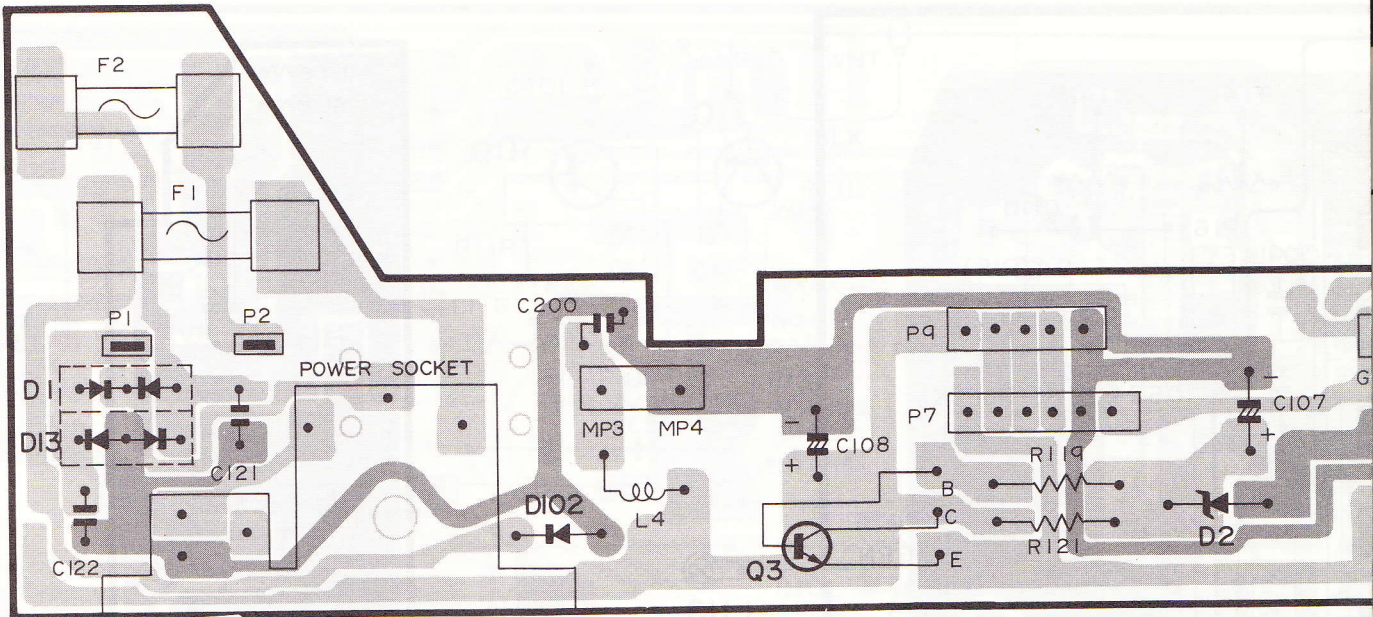

POWER P.C.B. [D-M1(U, C, W)]

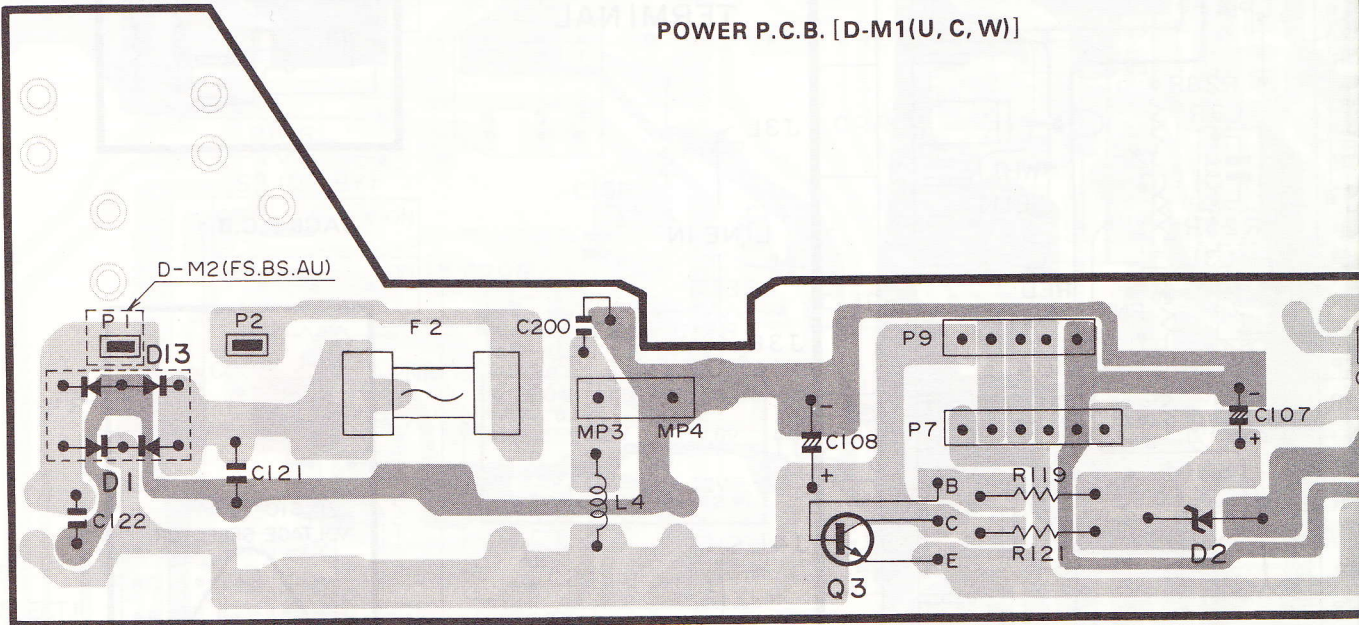

POWER P.C.B. [D-M2(FS, BS, AU, W)]

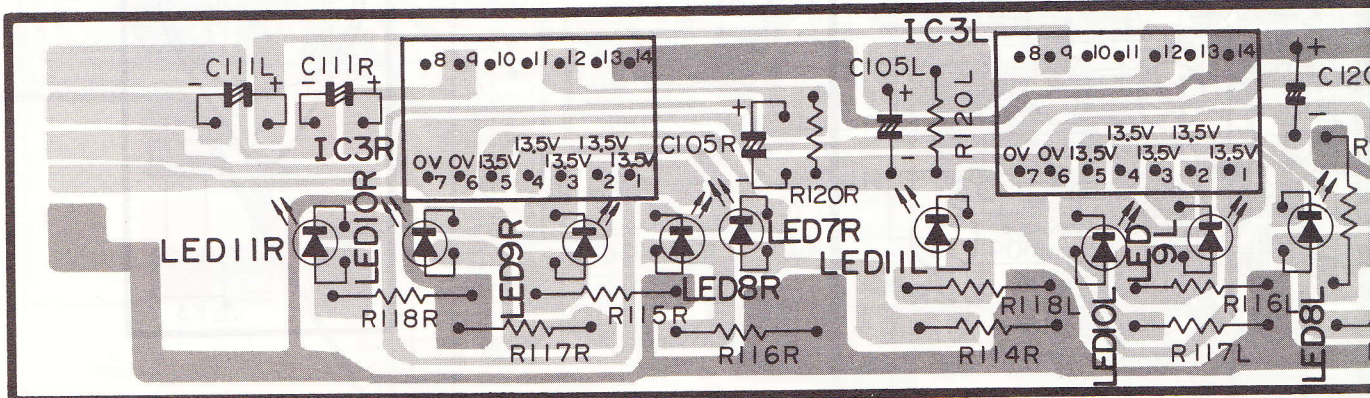

LEVEL INDICATOR P.C.B.

Ground : Signal, + B

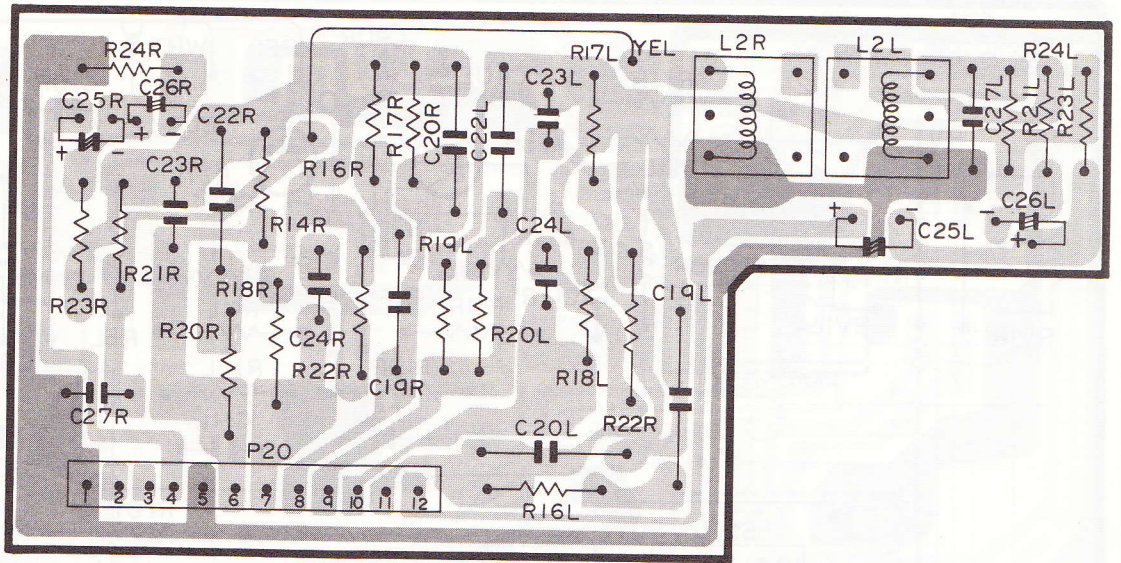
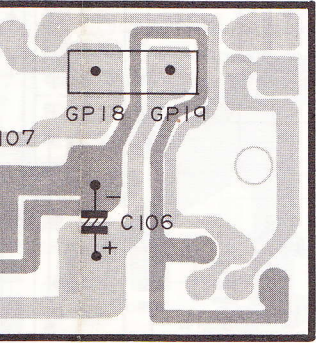

EQUALIZER P.C.B.

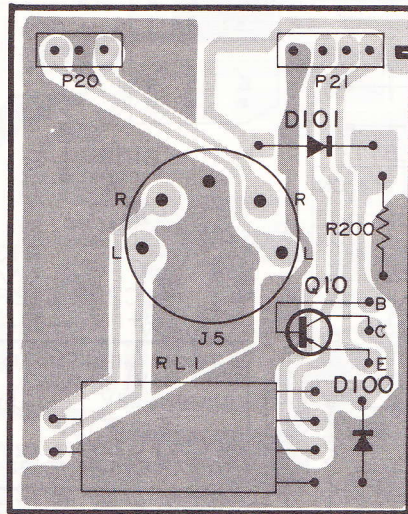
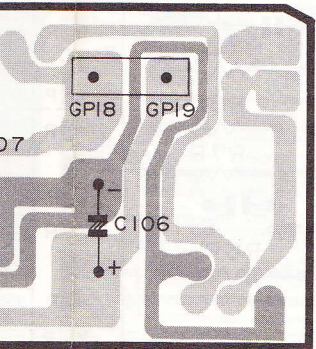

DIN JACK P.C.B. [D-M1(W)/D-M2(FS, BS, AU, W)]

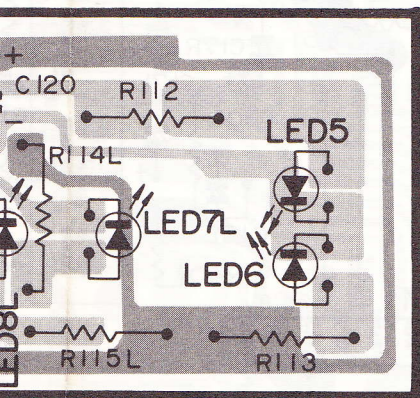

POWER SWITCH P.C.B.
[D-M1(U, C, W)/D-M2(W)]

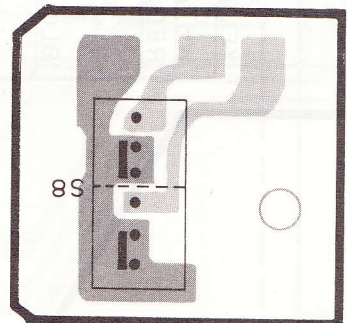
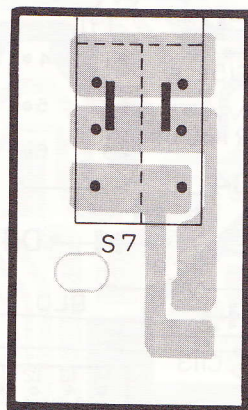

REC MUTE SWITCH P.C.B.

EXPLODED VIEW

IRM 24-01 10/11/70

2

SYMBOL-NO	P-NO	DESCRIPTION	SYMBOL-NO	P-NO	DESCRIPTION
FOR CASSETTE CHASSIS ASSEMBLY (B)			MISCELLANEOUS		
1	7319462	EJECT LEVER	18	6223663	FRONT PANEL ASSEMBLY [D-M1 (U, C)]
2	5559234	COUNTER		6223664	FRONT PANEL ASSEMBLY [D-M1 (W)]
3	6753282	COUNTER BUTTON		6223665	FRONT PANEL ASSEMBLY [D-M2 (FS, BS, AU, W)]
4	6354901	COUNTER BELT	19	6052072	PUSH BUTTON (REC MUTE)
5	6631794	LED PANEL	20	6532752	LEAF SPRING
6	0678312	DT SCREW - 2.6MMD x 12MM (BLACK)	21	6257871	EJECT BUTTON
7	6632592	CASSETTE METAL	22	6303784	SPRING
8	7316272	RECORD LEVER ASSEMBLY	23	6753111	BUTTON PIN
9	7321091	ADJUST PLATE	24	6052042	PUSH BUTTON (POWER)
10	6755011	POWER KNOB LEVER	25	6053141	PUSH BUTTON (DOLBY NR. INPUT)
△	11	6711352 BUSHING [D-M2 (BS)]	26	6287712	KNOB ASSEMBLY } (REC VOLUME)
△		6794071 BUSHING [D-M2 (W)]	27	6287663	
△		0043793 BUSHING [D-M2 (FS)]	28	6287622	SWITCH KNOB (TAPE SELECTOR)
△		6711351 BUSHING [D-M2 (AU)]	29	6092185	CASSETTE DOOR ASSEMBLY
12	8699412	BIND TAPPING SCREW - 3MMD x 12MM (BLACK)	30	6259761	PUSH BUTTON (BEAT)
13	7780915	BIND TAPPING SCREW - 2MMD x 5MM	31	6182125	HEAD COVER
14	6714213	NYLON RIVET	32	6041247	UPPER COVER [D-M1 (U, C, W)]
15	5659101	BACK COVER [D-M1 (U, C, W)]		6041248	UPPER COVER [D-M2 (FS, BS, AU, W)]
16	0671310	DT SCREW - 2.6MMD x 10MM	33	8699412	BIND TAPPING SCREW - 3MMD x 12MM (BLACK)
17	0671306	DT SCREW - 2.6MMD x 6MM [D-M2 (BS)]	34	7740372	RUBBER LEG
			35	8698412	BT BIND SCREW - 3MMD x 12MM
			36	8698410	BT BIND SCREW - 3MMD x 10MM

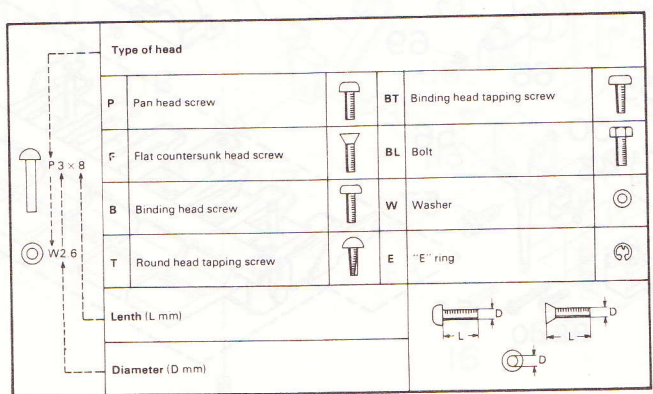

When ordering hardware excluding stated on these lists, be sure to make your orders with type and size.

EXPLODED VIEW

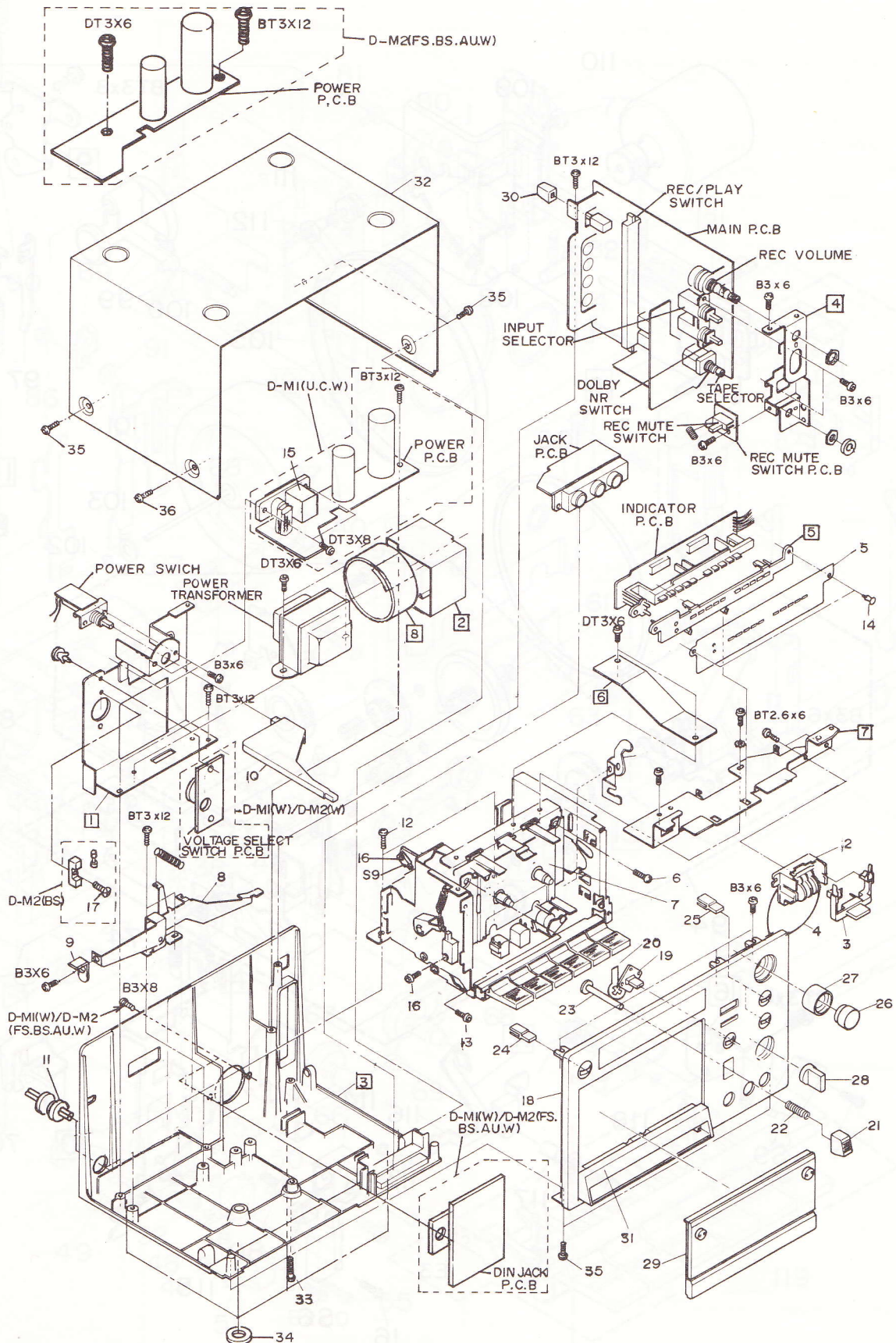

Note: Components marked with number in this drawing are not specified as replacement parts.

EXPLODED VIEW

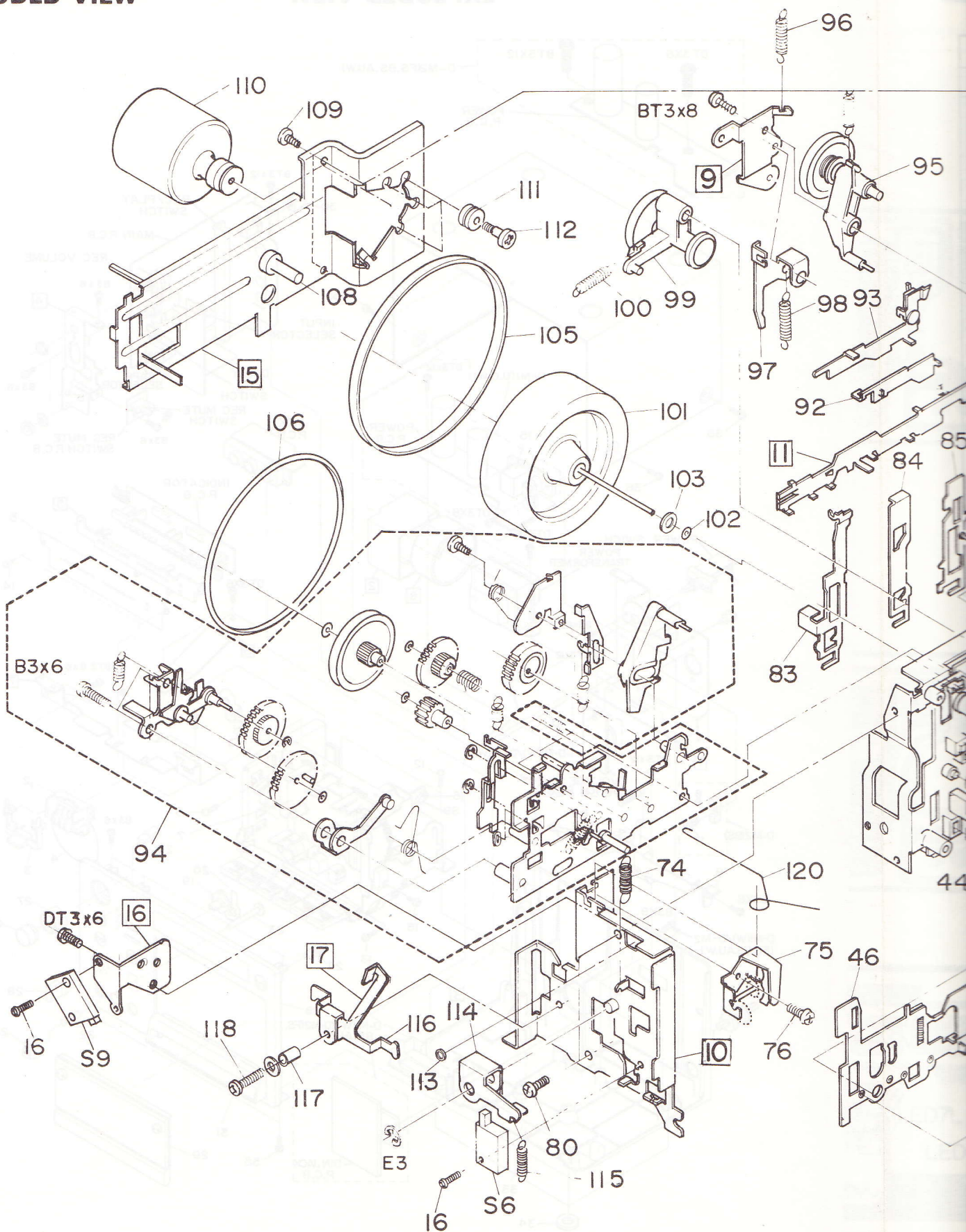

Note: Components marked with number in this drawing are not specified as replacement parts.

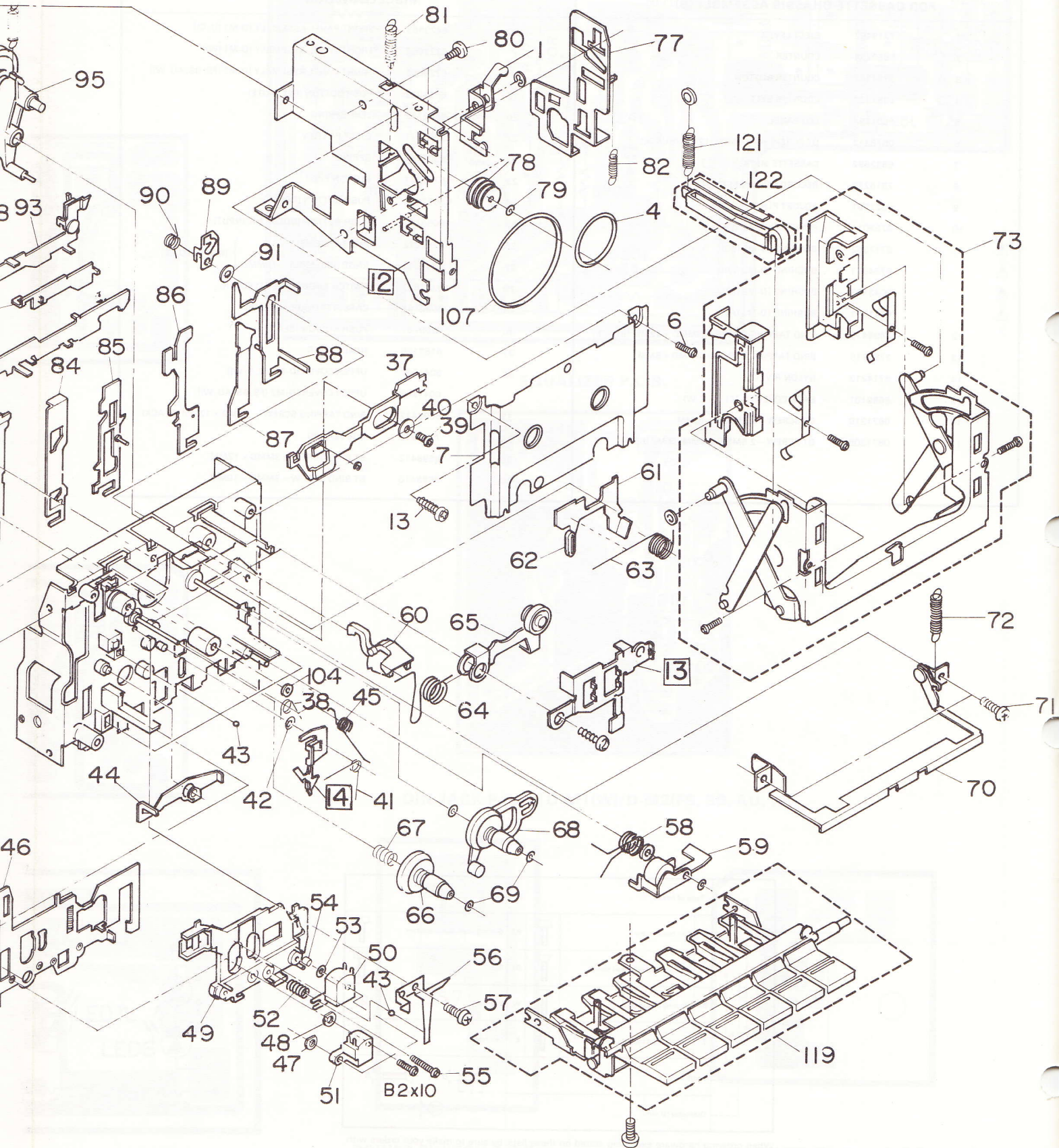

BLOCK DIAGRAM

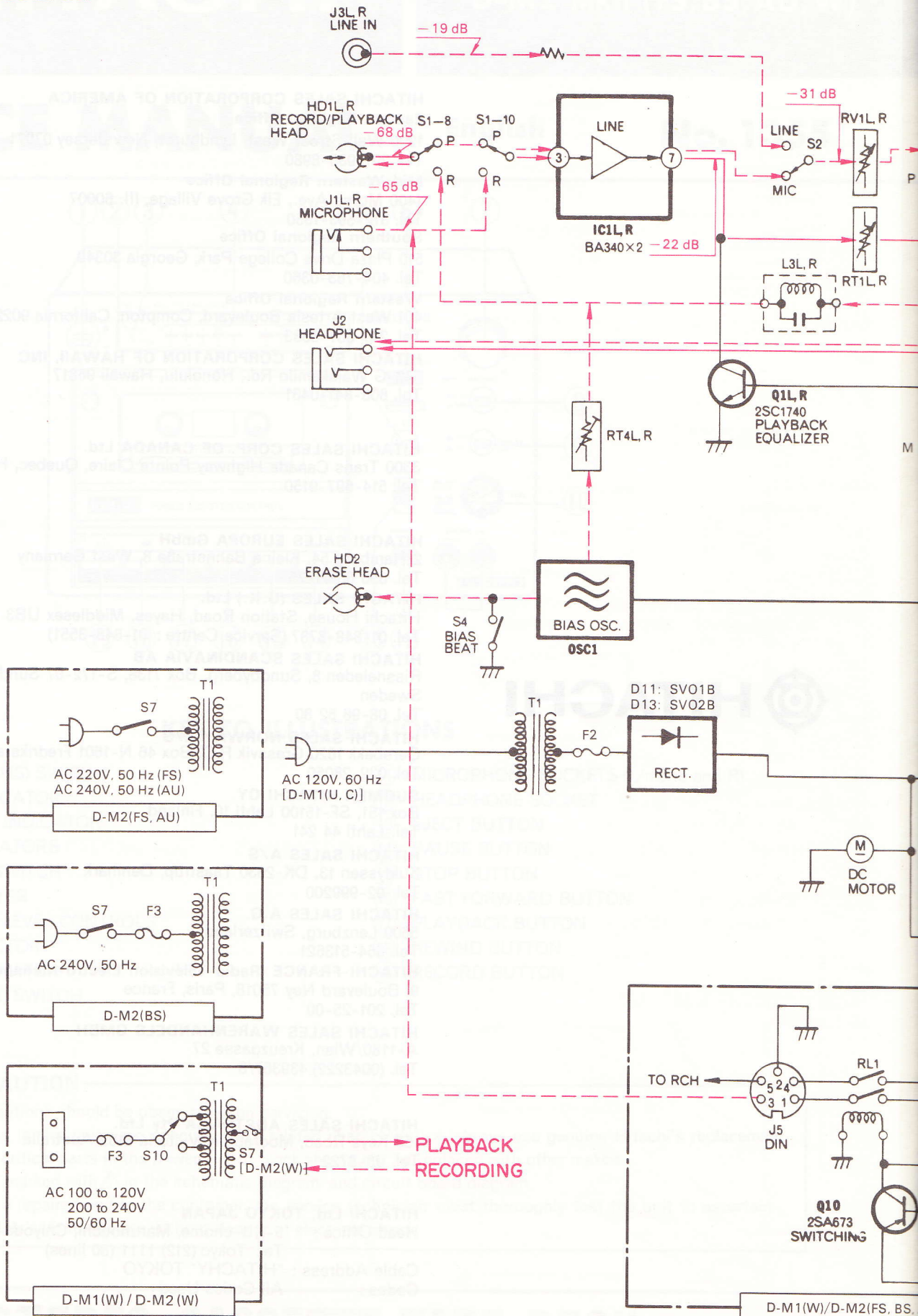

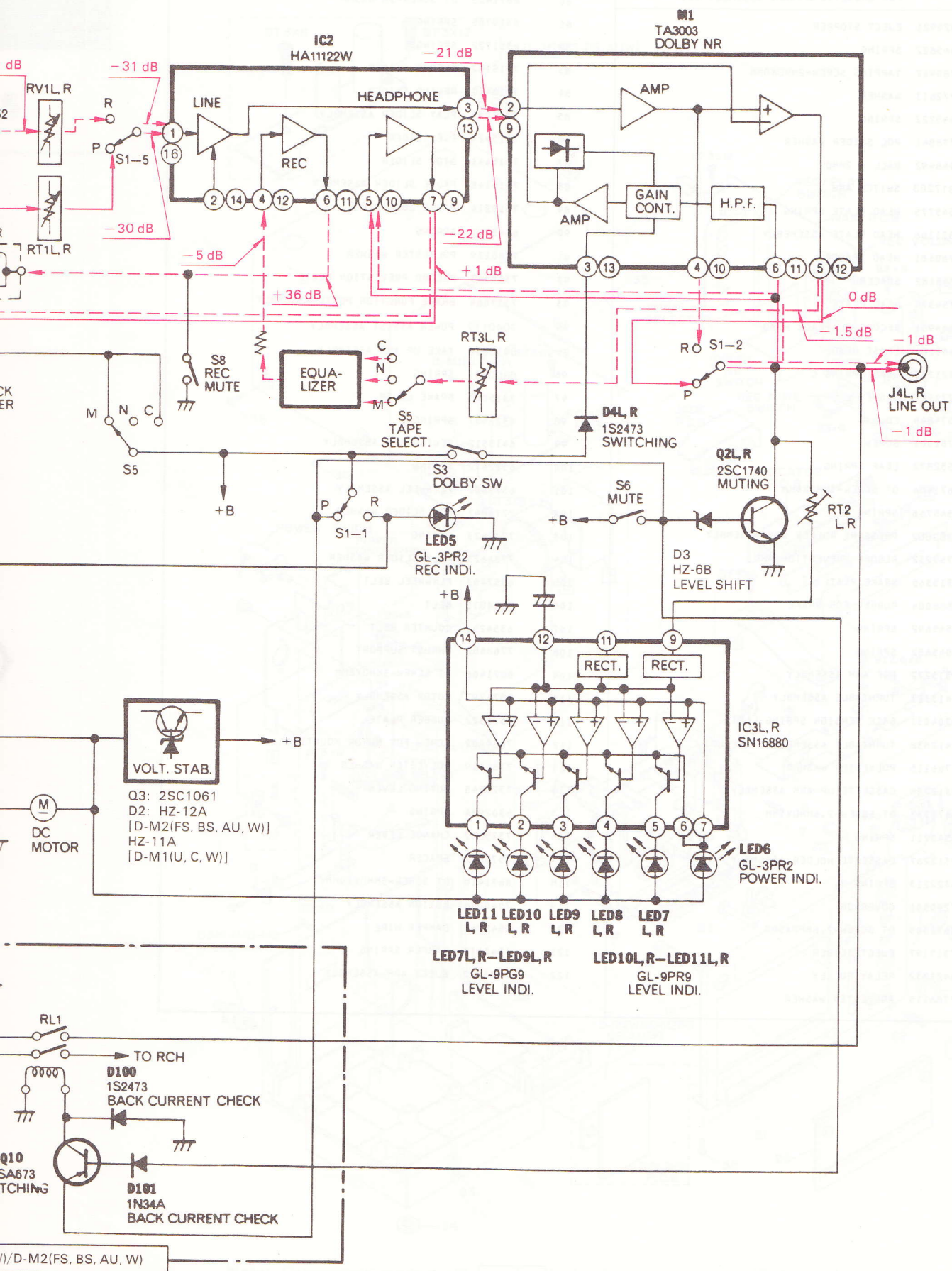



HITACHI SALES CORPORATION OF AMERICA

Eastern Regional Office

1200 Wall Street West, Lyndhurst, New Jersey 07071
Tel. 201-935-8980

Mid-Western Regional Office

1400 Morse Ave., Elk Grove Village, Ill. 60007
Tel. 312-593-1550

Southern Regional Office

510 Plaza Drive College Park, Georgia 30349
Tel. 404-763-0360

Western Regional Office

401 West Artesia Boulevard, Compton, California 90220
Tel. 213-537-8383

HITACHI SALES CORPORATION OF HAWAII, INC

743-G Waiakamilo Rd., Honolulu, Hawaii 96817
Tel. 808-841-0431

HITACHI SALES CORP. OF CANADA Ltd.

3300 Trans Canada Highway Pointe Claire, Quebec, H9R1B1, Canada
Tel. 514-697-9150

HITACHI SALES EUROPA GmbH

2 Hamburg 54, Kleine Bahnstraße 8, West Germany
Tel. 850 60 71-75

HITACHI SALES (U.K.) Ltd.

Hitachi House, Station Road, Hayes, Middlesex UB3 4DR, England
Tel. 01-848-8787 (Service Centre : 01-848-3551)

HITACHI SALES SCANDINAVIA AB

Rissneleden 8, Sundbyberg, Box 7138, S-172-07 Sundbyberg 7, Sweden
Tel. 08-98 52 80

HITACHI SALES NORWAY A/S

Oerebekk 1620 Gressvik P.O. Box 46 N-1601 Fredrikstad, Norway
Tel. 032-28050

SUOMEN HITACHI OY

Box 151, SF-15100 Lahti 10, Finland
Tel. Lahti 44 241

HITACHI SALES A/S

Kuldysen 13, DK-2630 Taastrup, Denmark
Tel. 02-999200

HITACHI SALES A.G.

5600 Lenzburg, Switzerland
Tel. 064-513621

HITACHI-FRANCE (Radio-Télévision Electro-Ménager) S.A.

9, Boulevard Ney 75018, Paris, France
Tel. 201-25-00

HITACHI SALES WARENHANDELS GMBH

A-1180/Wien, Kreuzgasse 27
Tel. (0043222) 439367/8

HITACHI SALES AUSTRALIA Pty Ltd.

153 Keys Road, Moorabbin, Victoria 3189 Australia
Tel. 95-8722

HITACHI Ltd. TOKYO JAPAN

Head Office : 5-1, 1-chome, Marunouchi, Chiyoda-ku, Tokyo
Tel. Tokyo (212) 1111 (80 lines)

Cable Address : "HITACHY" TOKYO

Codes : All Codes Used