

HITACHI

SM0093



SERVICE MANUAL MANUEL D'ENTRETIEN WARTUNGSHANDBUCH

DR100E
DR100EBS
DR100UC
DR100W
DR100WUN

CAUTION:

Before servicing this chassis, it is important that the service technician read the "Safety Precautions" and "Product Safety Notices" in this service manual.

ATTENTION:

Avant d'effectuer l'entretien du châassis, le technicien doit lire les «Précautions de sécurité» et les «Notices de sécurité du produit» présentés dans le présent manuel.

VORSICHT:

Vor Öffnen des Gehäuses hat der Service-Ingenieur die „Sicherheitshinweise“ und „Hinweise zur Produktsicherheit“ in diesem Wartungshandbuch zu lesen.

Data contained within this Service manual is subject to alteration for improvement.

Les données fournies dans le présent manuel d'entretien peuvent faire l'objet de modifications en vue de perfectionner le produit.

Die in diesem



October 1999

SAFETY PRECAUTIONS

WARNING: The following precautions must be observed.

ALL PRODUCTS

1. Before any service is performed on the chassis an isolation transformer should be inserted between the power line and the product.
2. When replacing the chassis in the cabinet, ensure all the protective devices are put back in place.
3. When service is required, observe the original lead dressing. Extra precaution should be taken to ensure correct lead dressing in any high voltage circuitry area.
4. Many electrical and mechanical parts in HITACHI products have special safety related characteristics. These characteristics are often not evident from visual inspection, nor can the protection afforded by them necessarily be obtained by using replacement components rated for higher voltage, wattage, etc. Replacement parts which have these special safety characteristics are identified by marking with a  on the schematics and the replacement parts list.

The use of a substitute replacement component that does not have the same safety characteristics as the HITACHI recommended replacement one, shown in the parts list, may create electrical shock, fire, X-radiation, or other hazards.

5. Always replace original spacers and maintain lead lengths. Furthermore, where a short circuit has occurred, replace those components that indicate evidence of overheating.
6. Insulation resistance should not be less than 2M ohms at 500V DC between the main poles and any accessible metal parts.
7. No flashover or breakdown should occur during the dielectric strength test, applying 3kV AC or 4.25kV DC for two seconds between the main poles and accessible metal parts.
8. Before returning a serviced product to the customer, the service technician must thoroughly test the unit to be certain that it is completely safe to operate without danger of electrical shock. The service technician must make sure that no protective device built into the instrument by the manufacturer has become defective, or inadvertently damaged during servicing.

CE MARK

1. HITACHI products may contain the CE mark on the rating plate indicating that the product contains parts that have been specifically approved to provide electromagnetic compatibility to designated levels.
2. When replacing any part in this product, please use only the correct part itemised in the parts list to ensure this standard is maintained, and take care to replace lead dressing to its original state, as this can have a bearing on the electromagnetic radiation/immunity.

PICTURE TUBE

1. The line output stage can develop voltages in excess of 25kV; if the E.H.T. cap is required to be removed, discharge the anode to chassis via a high value resistor, prior to its removal from the picture tube.
2. High voltage should always be kept at the rated value of the chassis and no higher. Operating at higher voltages may cause a failure of the picture tube or high voltage supply, and also, under certain circumstances could produce X-radiation levels moderately in excess of design levels. The high voltage must not, under any circumstances, exceed 29kV on the chassis (except for projection Televisions).
3. The primary source of X-radiation in the product is the picture tube. The picture tube utilised for the above mentioned function in this chassis is specially constructed to limit X-radiation. For continued X-radiation protection, replace tube with the same type as the original HITACHI approved type
4. Keep the picture tube away from the body while handling. Do not install, remove, or handle the picture tube in any manner unless shatterproof goggles are worn. People not so equipped should be kept away while picture tubes are handled

LASERS

If the product contains a laser avoid direct exposure to the beam when the cover is open or when interlocks are defeated or have failed.

Specifications

Track system:	4-track 2-channel	
Recording system:	AC Bias	
Erasing system:	AC Bias	
Tape speed:	4.75 cm/s	
Included circuits:	Dolby B and C NR, Dolby HX Pro	
Usable tapes::	Normal:	40 - 15,000 Hz
	CrO2:	40 - 16,000 Hz
	Metal:	40 - 17,000 Hz
Power supply:	AC 230 V, 50 Hz (E/EBS), AC 120V 60 Hz (UC), AC 110-127/220-240V 50/60 Hz (W/WUN)	
Power consumption:	13 W (UC, E, EBS, W, WUN)	
Maximum external dimensions:	210 (W) x 96.5 (H) x 316 (D) mm (including feet, controls and terminals)	
Weight:	2.7 kg	
* Specifications are subject to change without notice for performance improvements		

Removal of Top Cover

1. Remove 1 screw ① from each side.
2. Remove 6 screws ② from the rear plate.

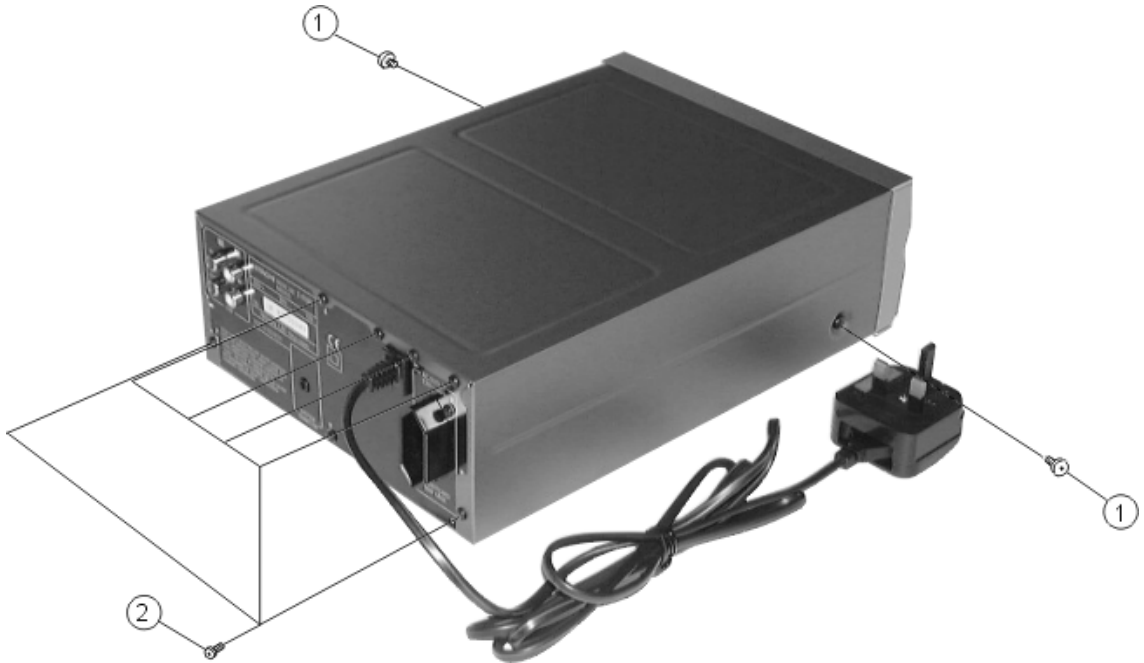

Removal of Rear Plate

1. Remove 3 screws ③ and 1 screw ② from the rear plate.

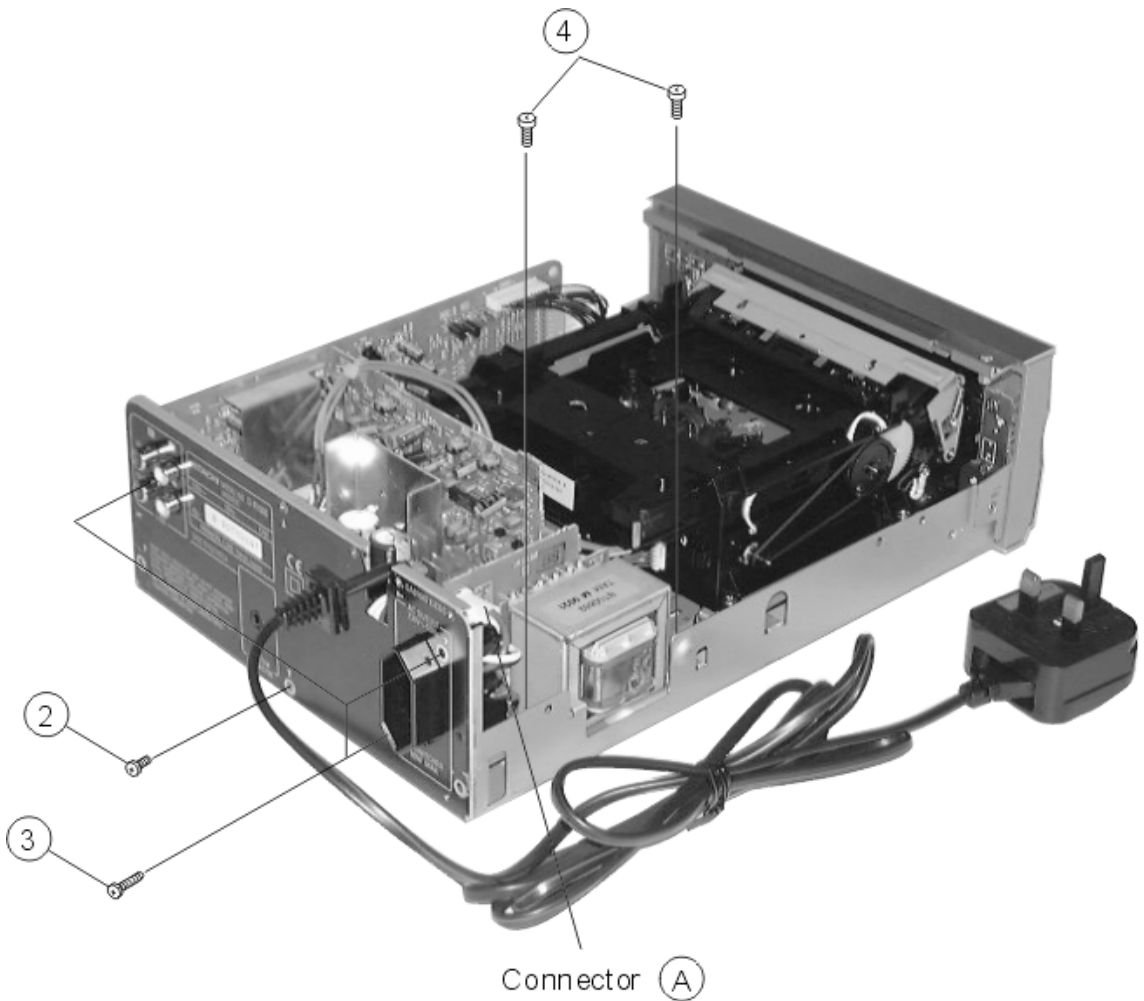

Removal of Power Cord

1. Detach the power cord connector from connector ③.

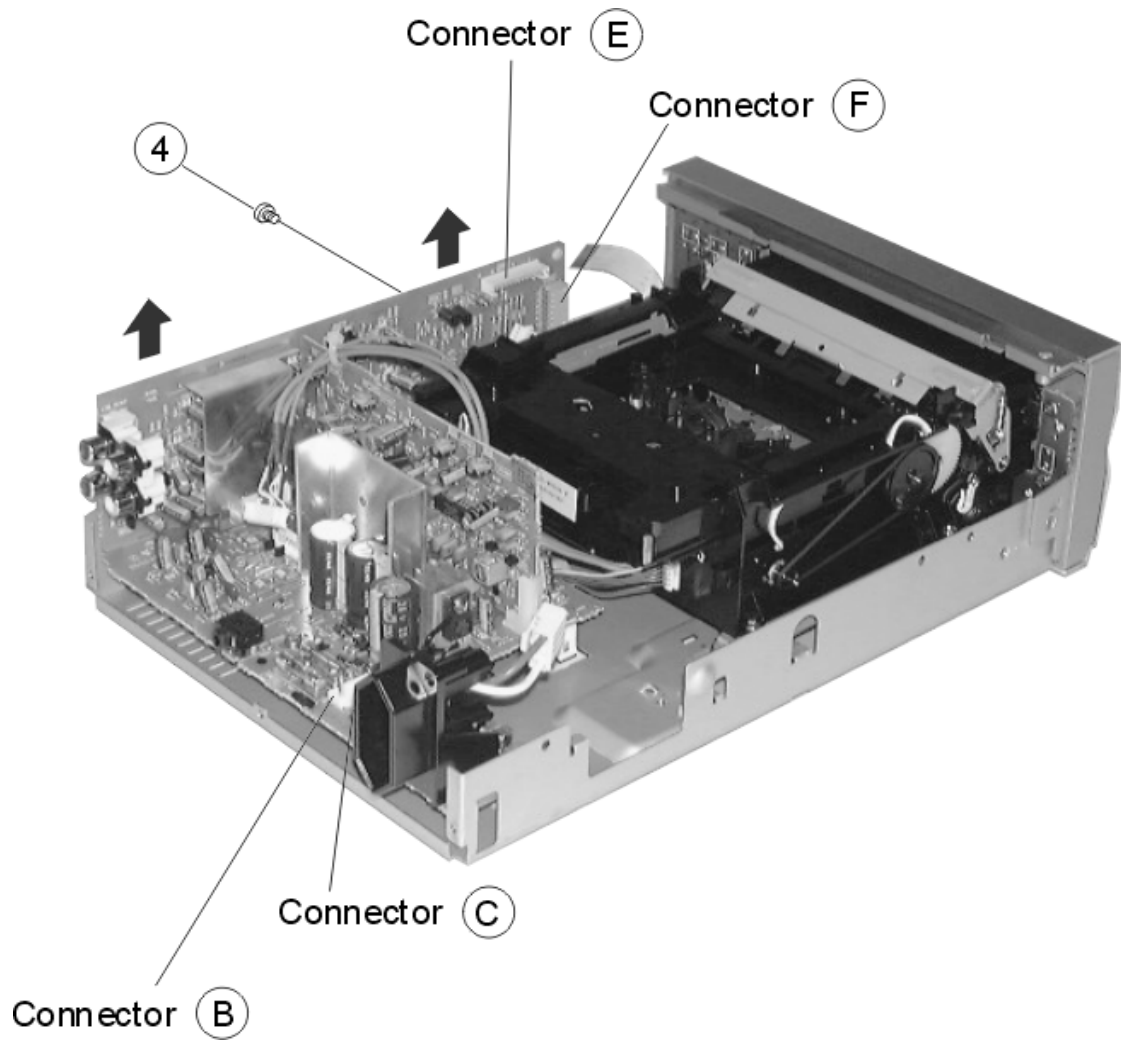

Removal of Transformer

1. Remove 2 screws ④ from the transformer.
2. Pull the transformer upwards to detach its connectors ① and ② from the main P.W.B. board.

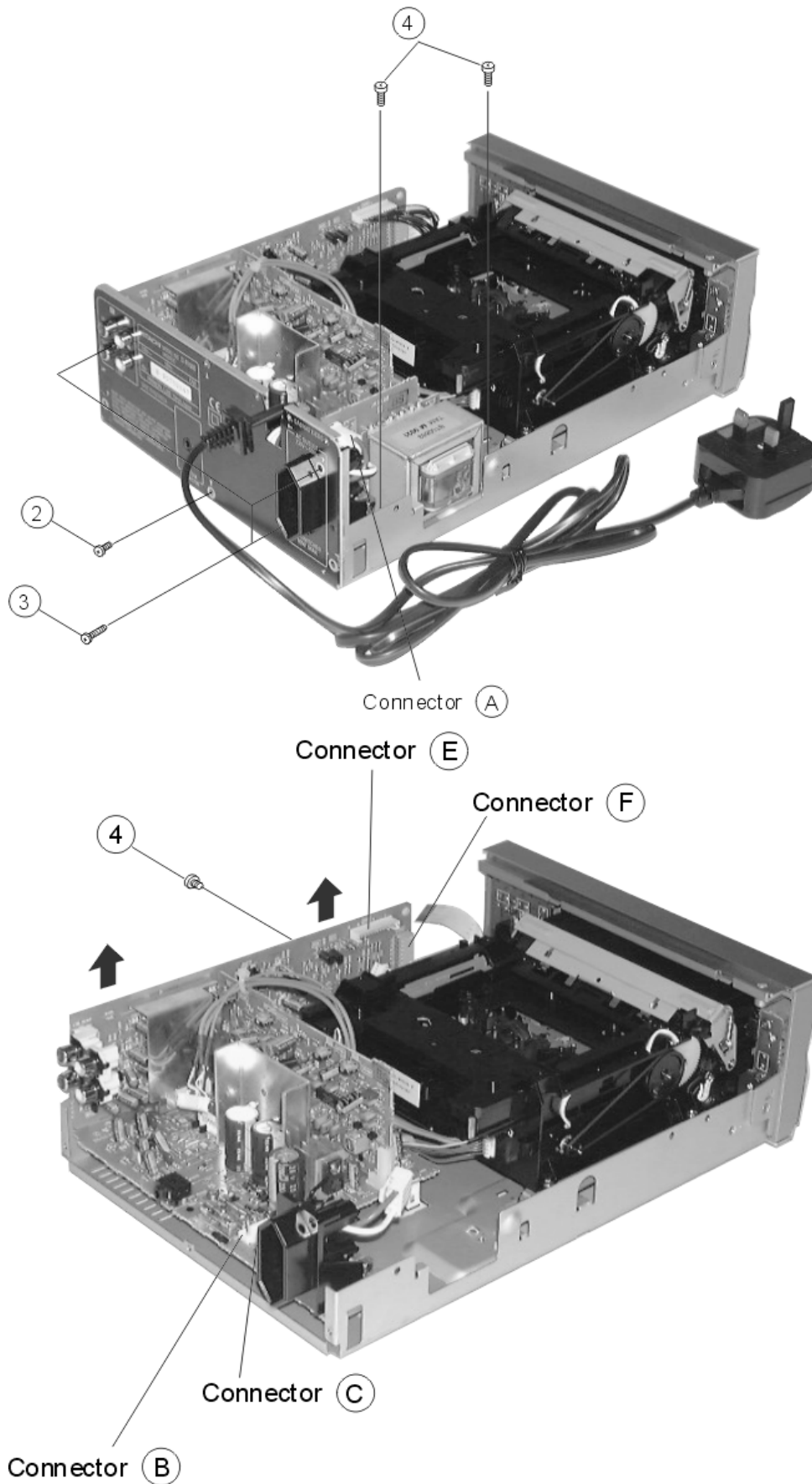

Removal of PB P.W.B. Board

1. Remove 1 screw ④ from the base plate at the side.
2. Gently pull the PB P.W.B. board upwards to detach its 2 connectors ⑤ from the main P.W.B. board and free the connector ⑥ and ⑦.

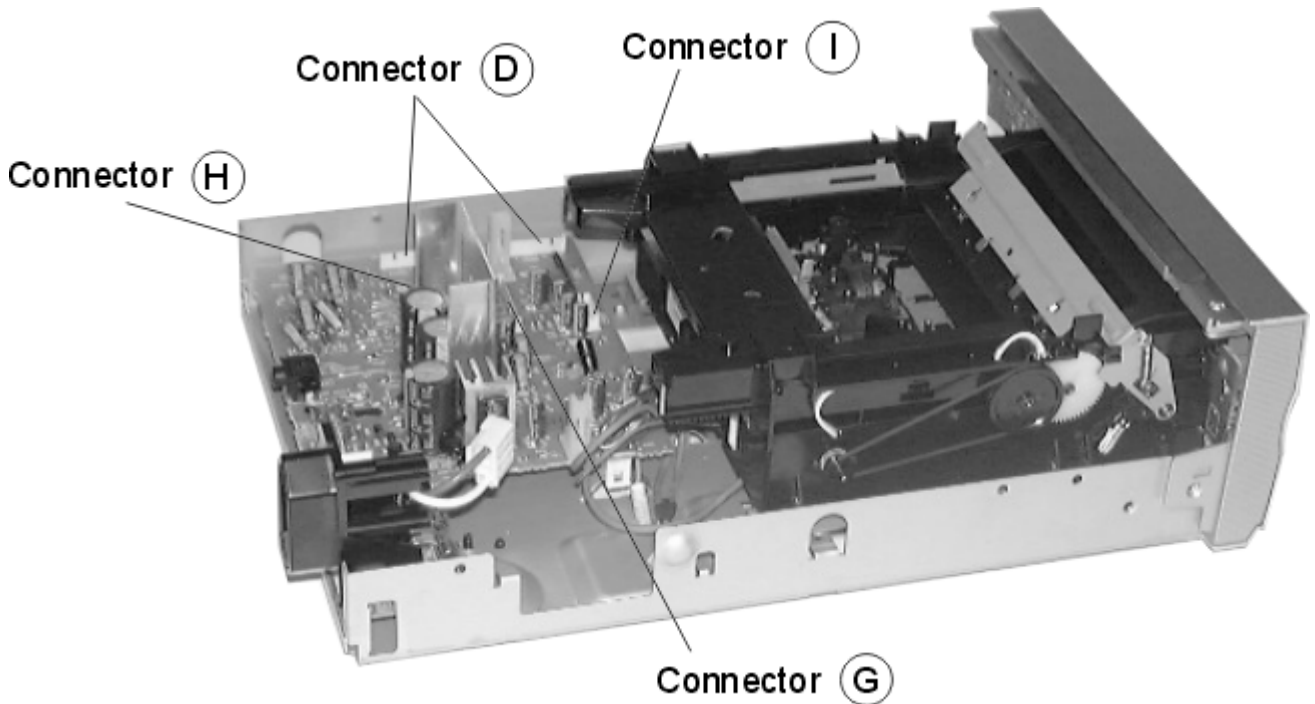
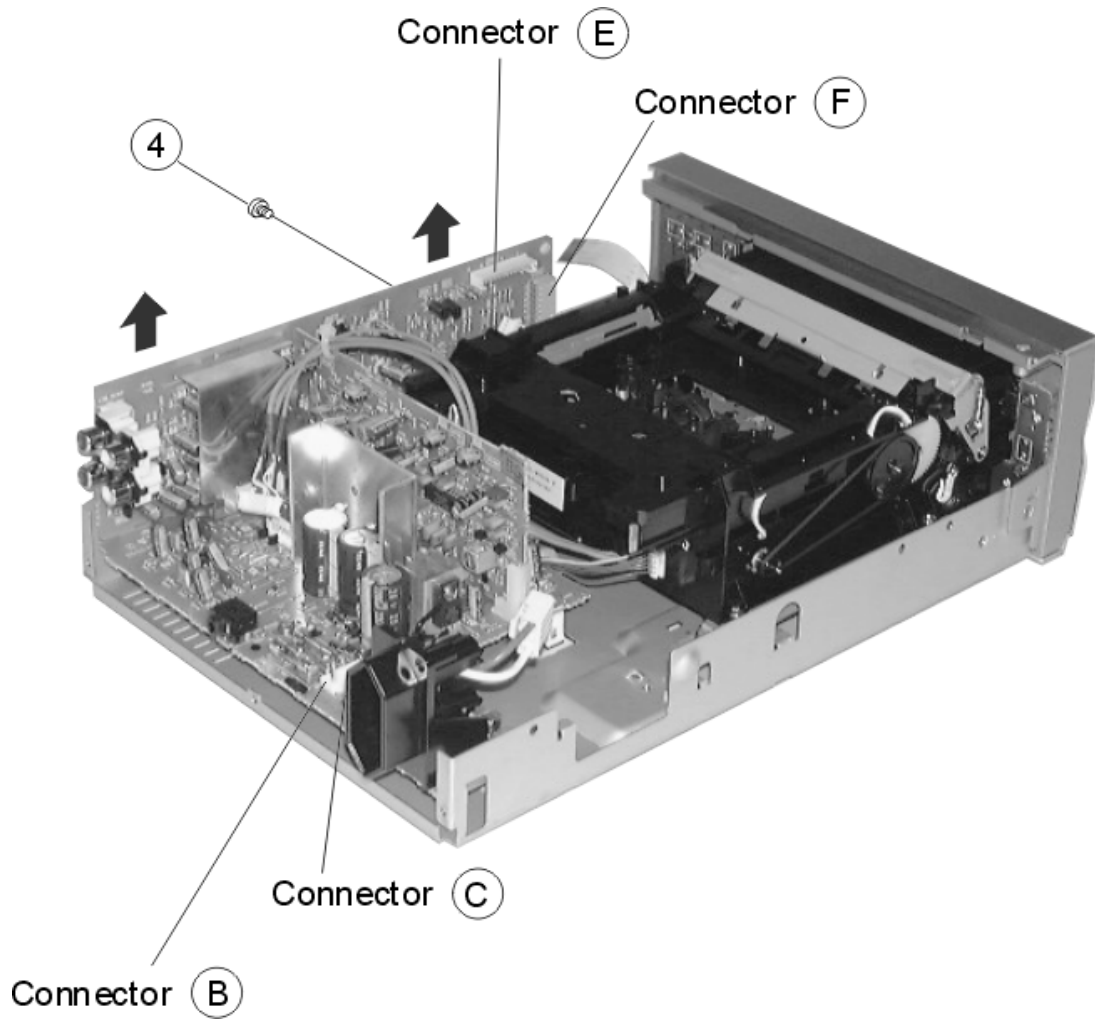

Removal of REC P.W.B. Board

1. Release the REC P.W.B. board from its holding claws and then gently pull the board free of the connector ③.

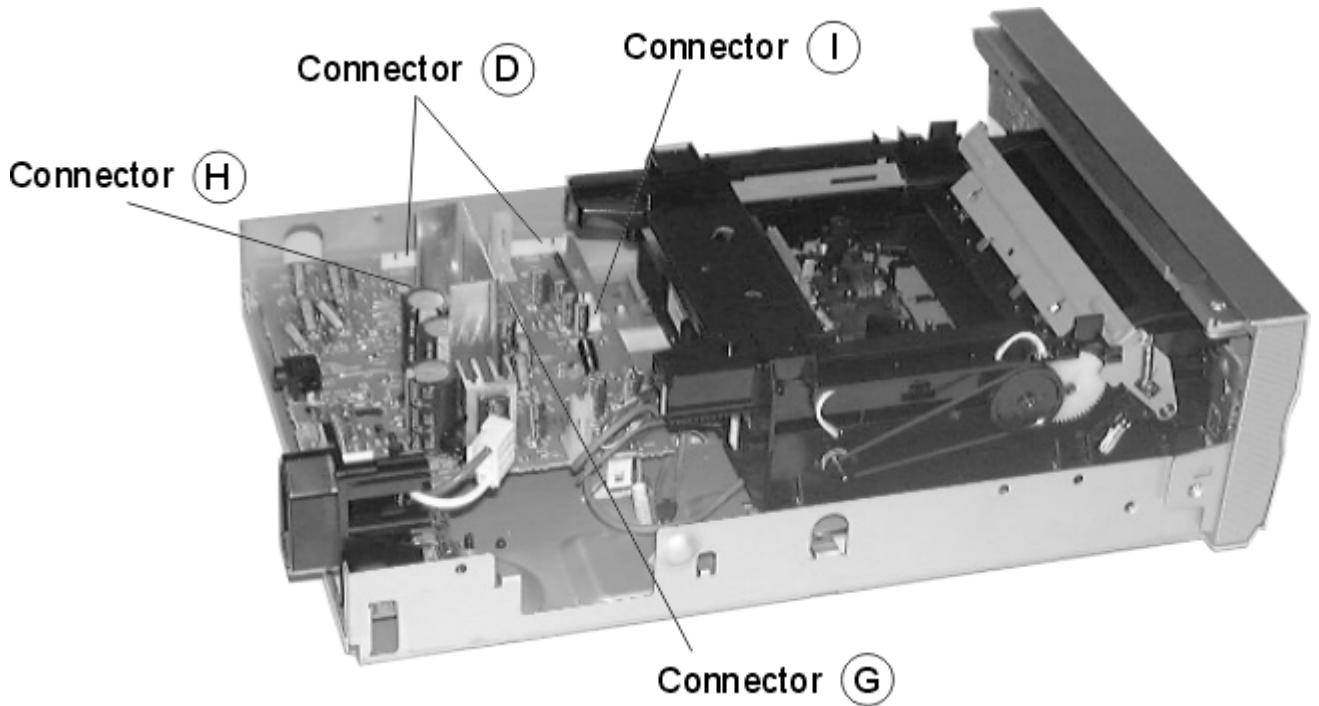
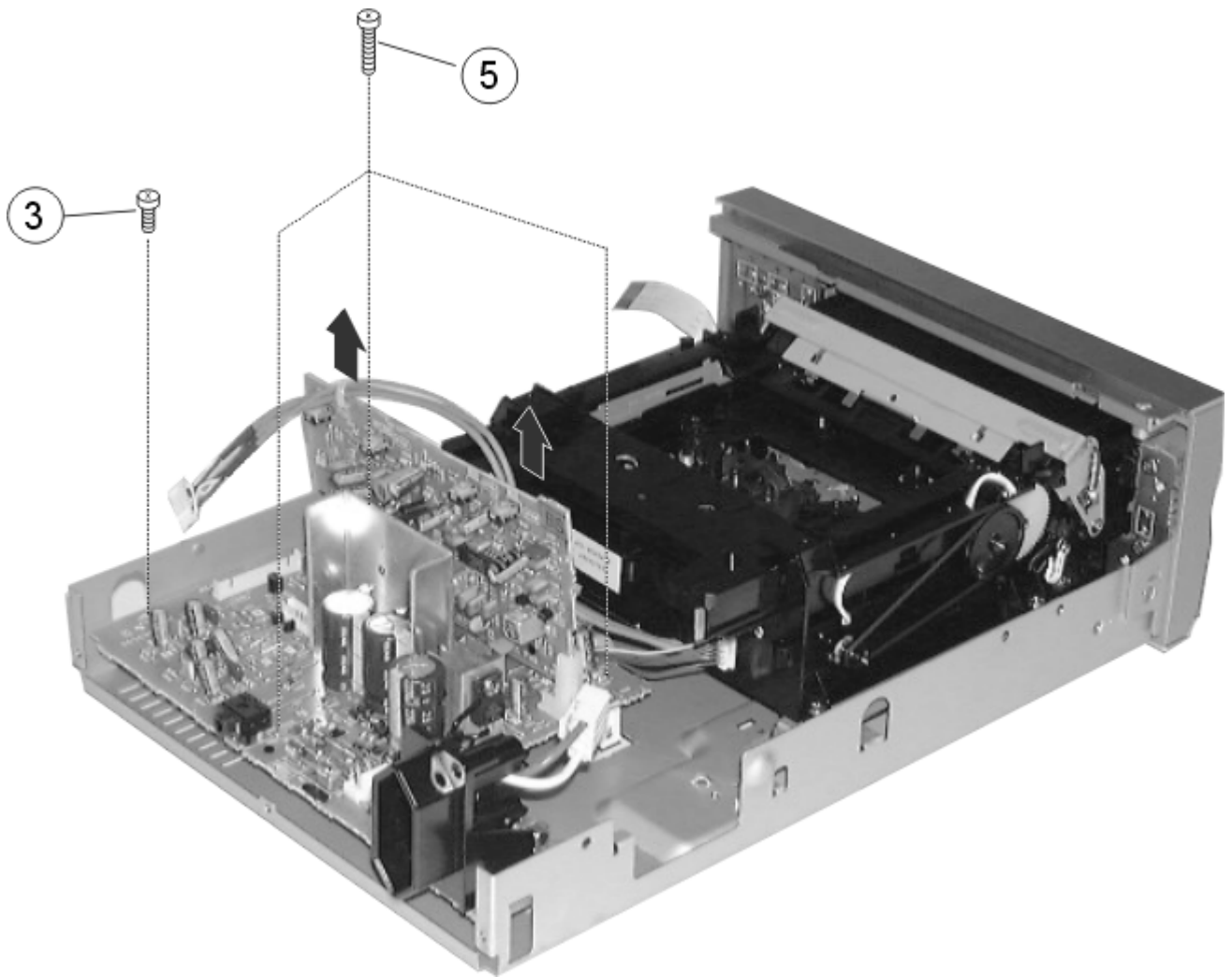

Removal of Main P.W.B. Board

1. Remove the remaining connectors ③ (see Removing Power cord), ④ and ① from the main P.W.B. board.
2. Remove 3 screws ⑤ and 1 screw ③ from the main P.W.B. board.

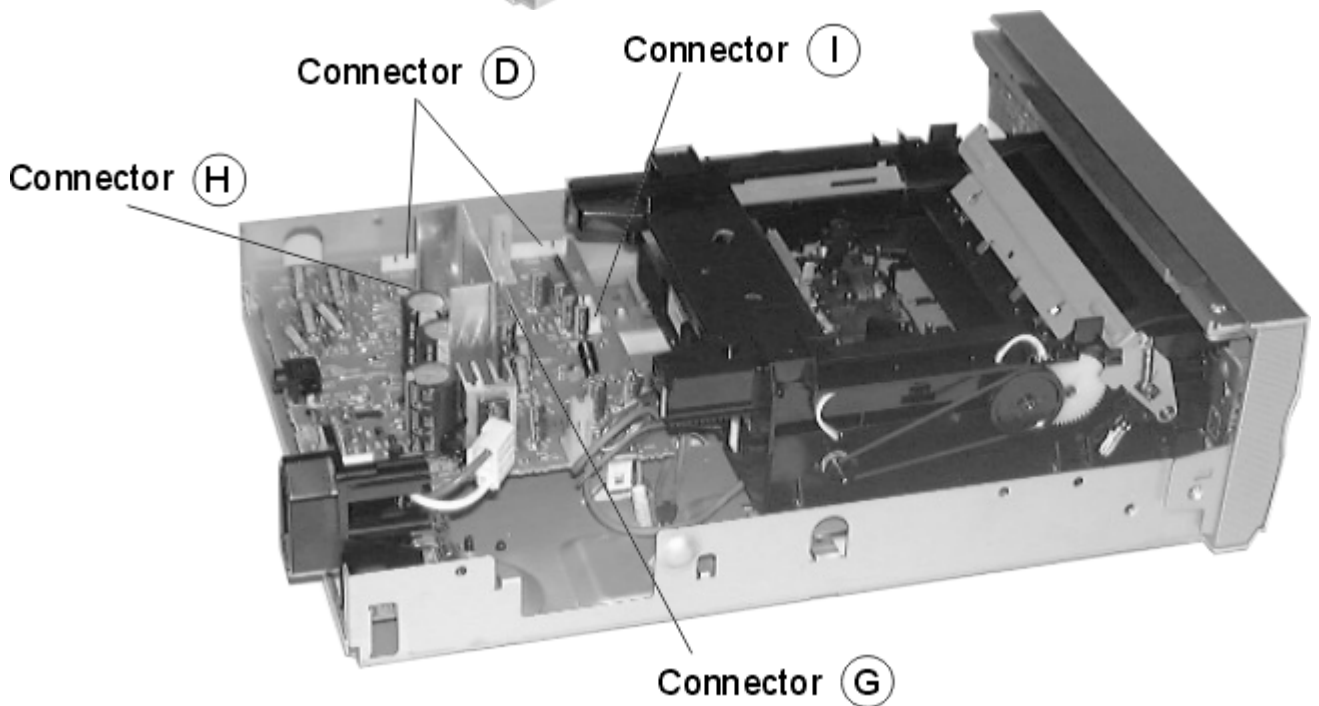
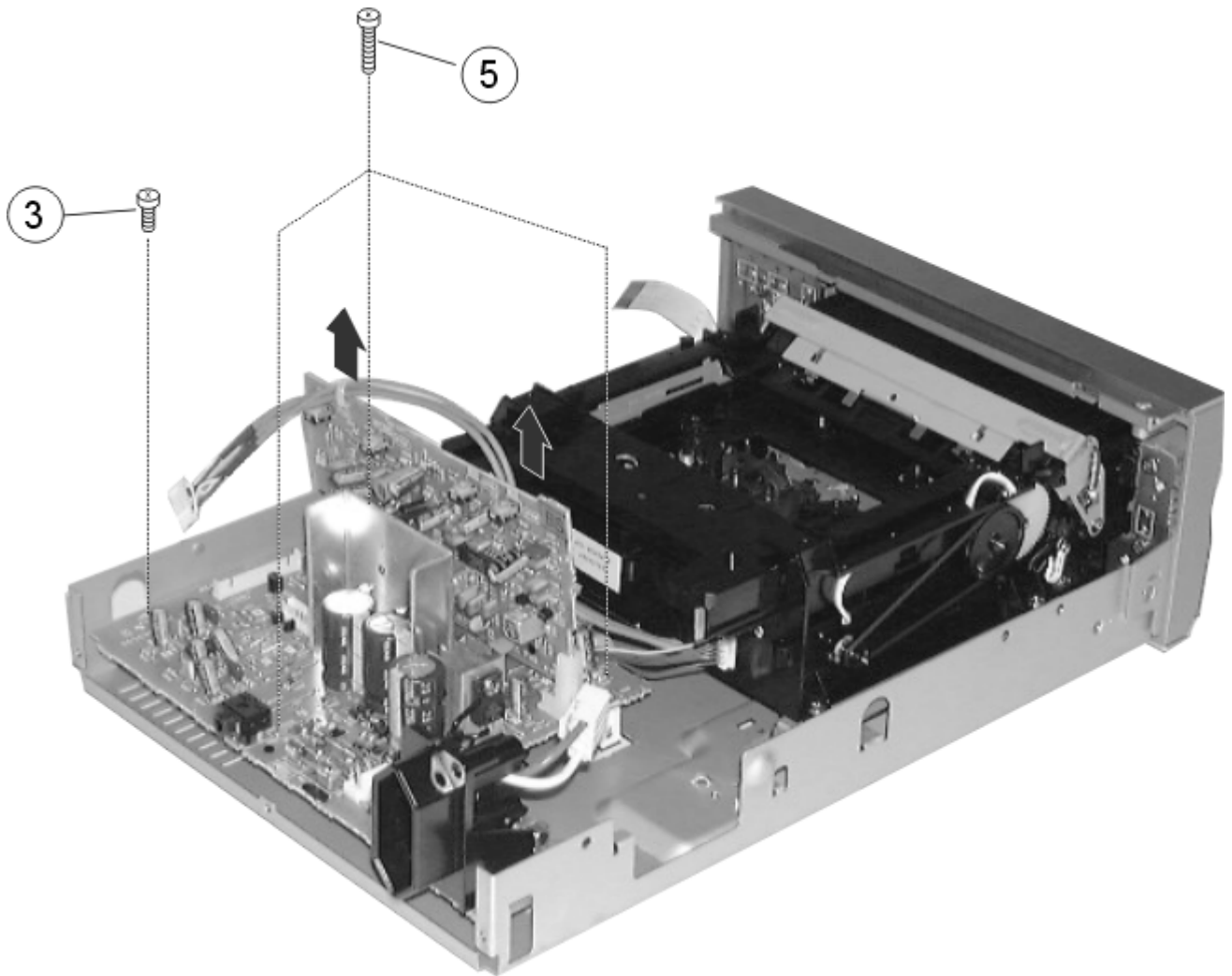

Removal of Front Panel

- 1. Remove 1 screw ⑥ from each side of the base plate.
- 2. Invert the base plate and remove the 4 screws ③.
- 3. Remove the Front Panel after releasing the connector ⑤.

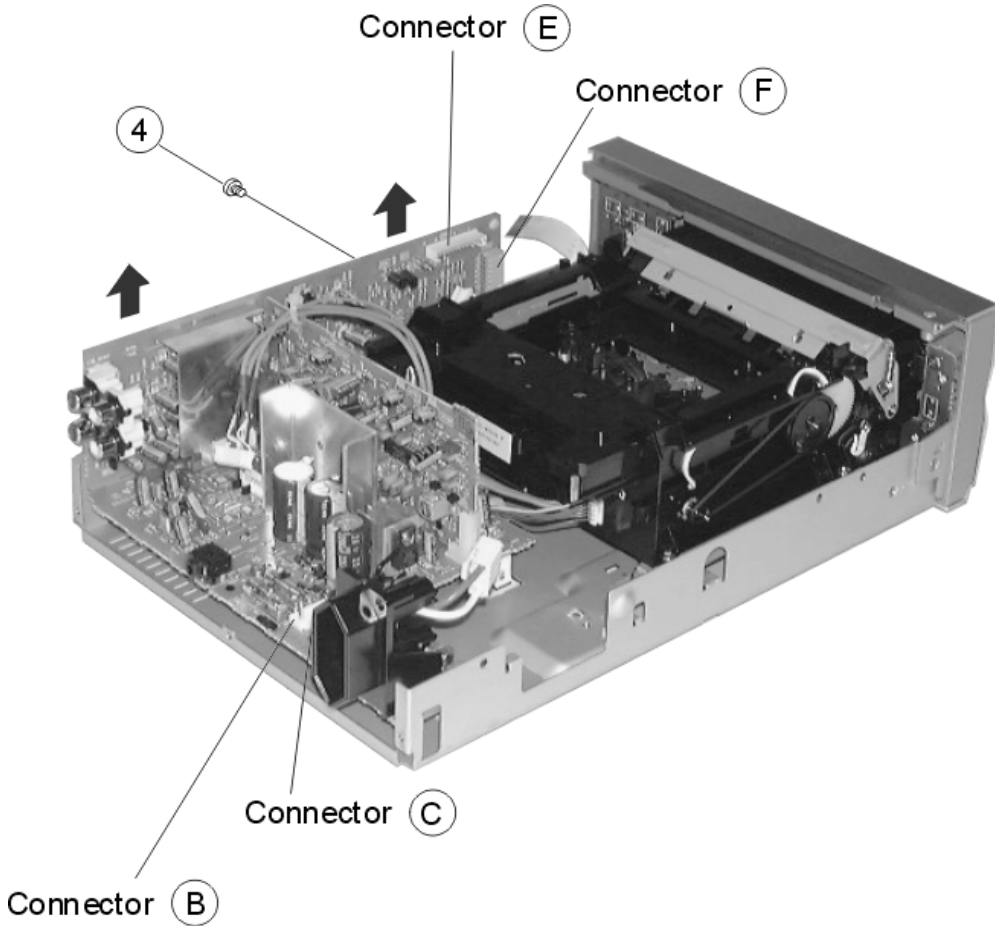
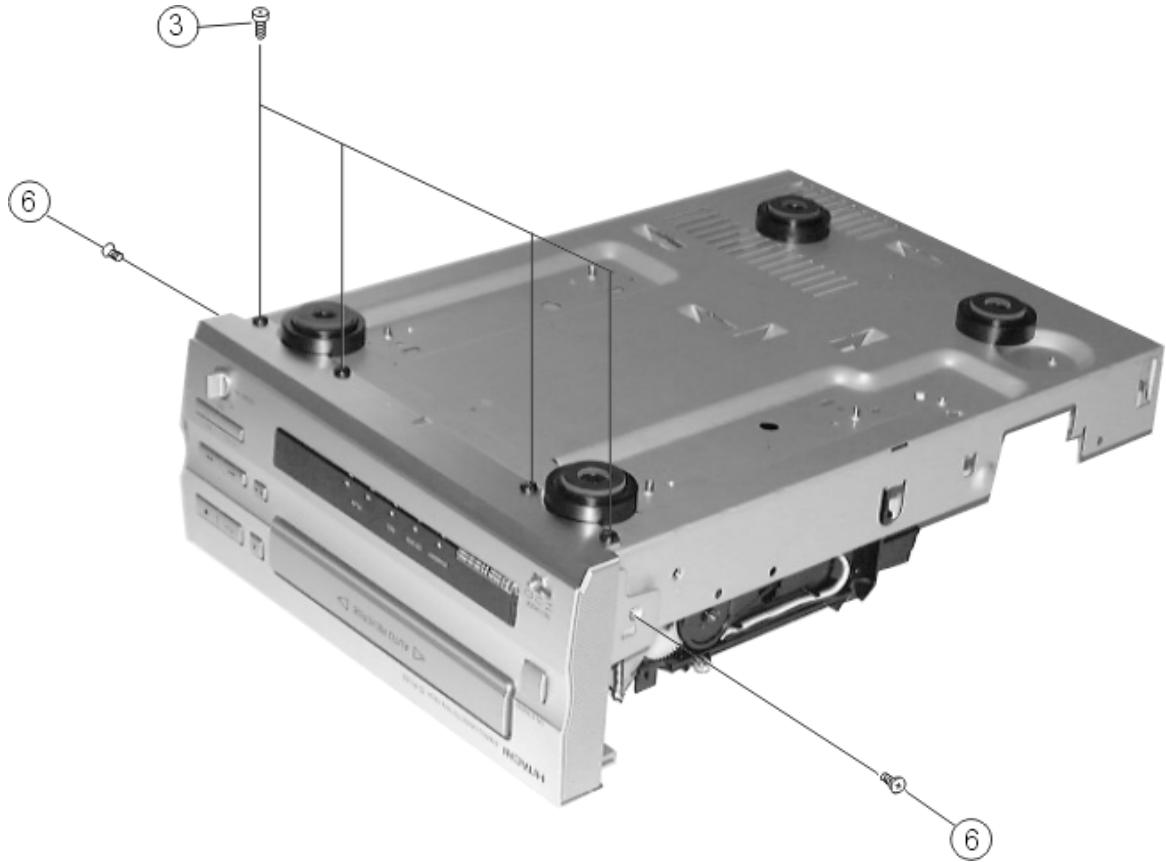

Removal of Deck Mechanism and P.W.B. Holder

1. Remove 4 screws ⑦ and then remove the deck mechanism.
2. Remove 3 screws ⑧ and then remove P.W.B. Holder.

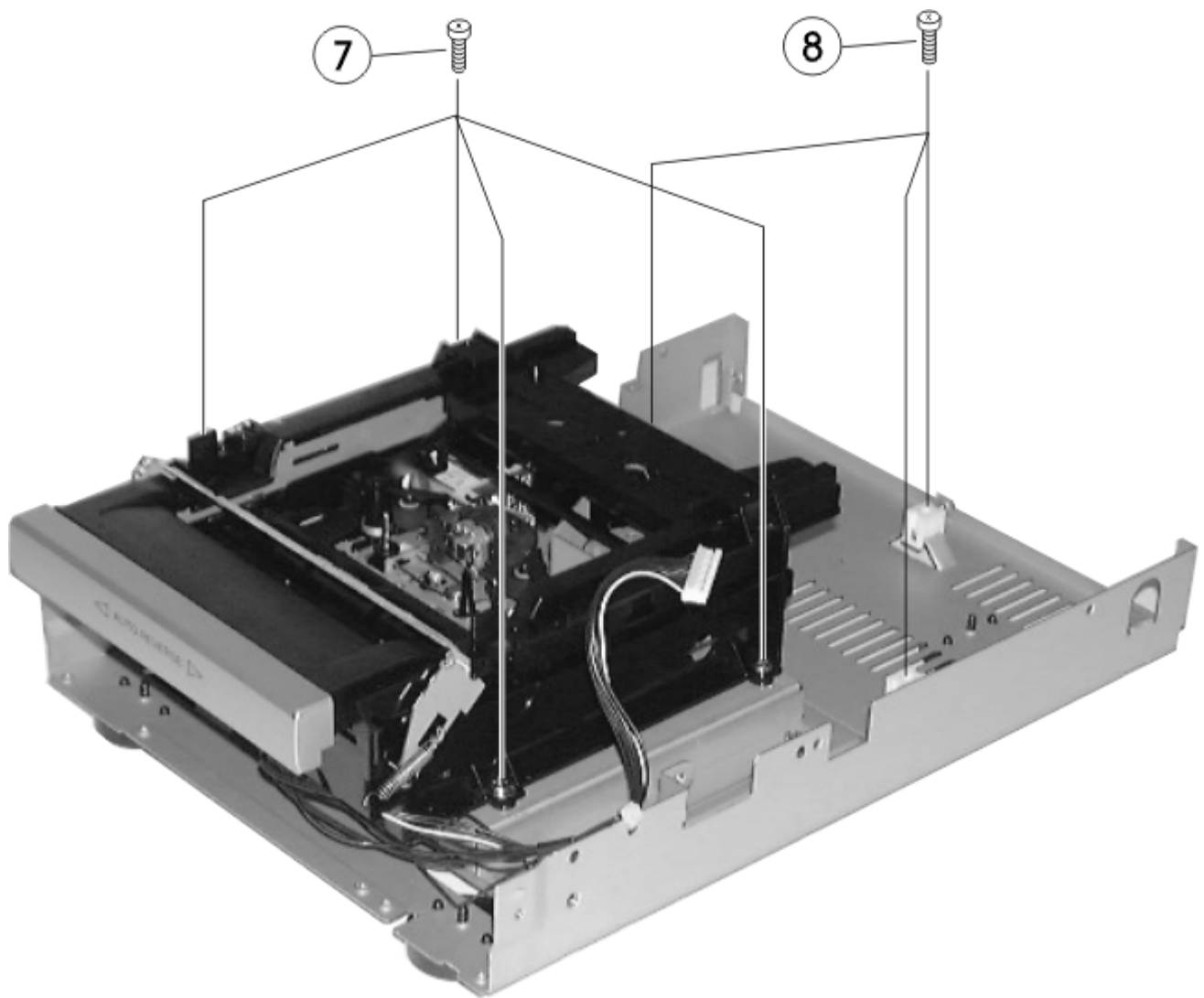

Removal of Foot

1. Remove 4 screws ⑨ and then remove foot.

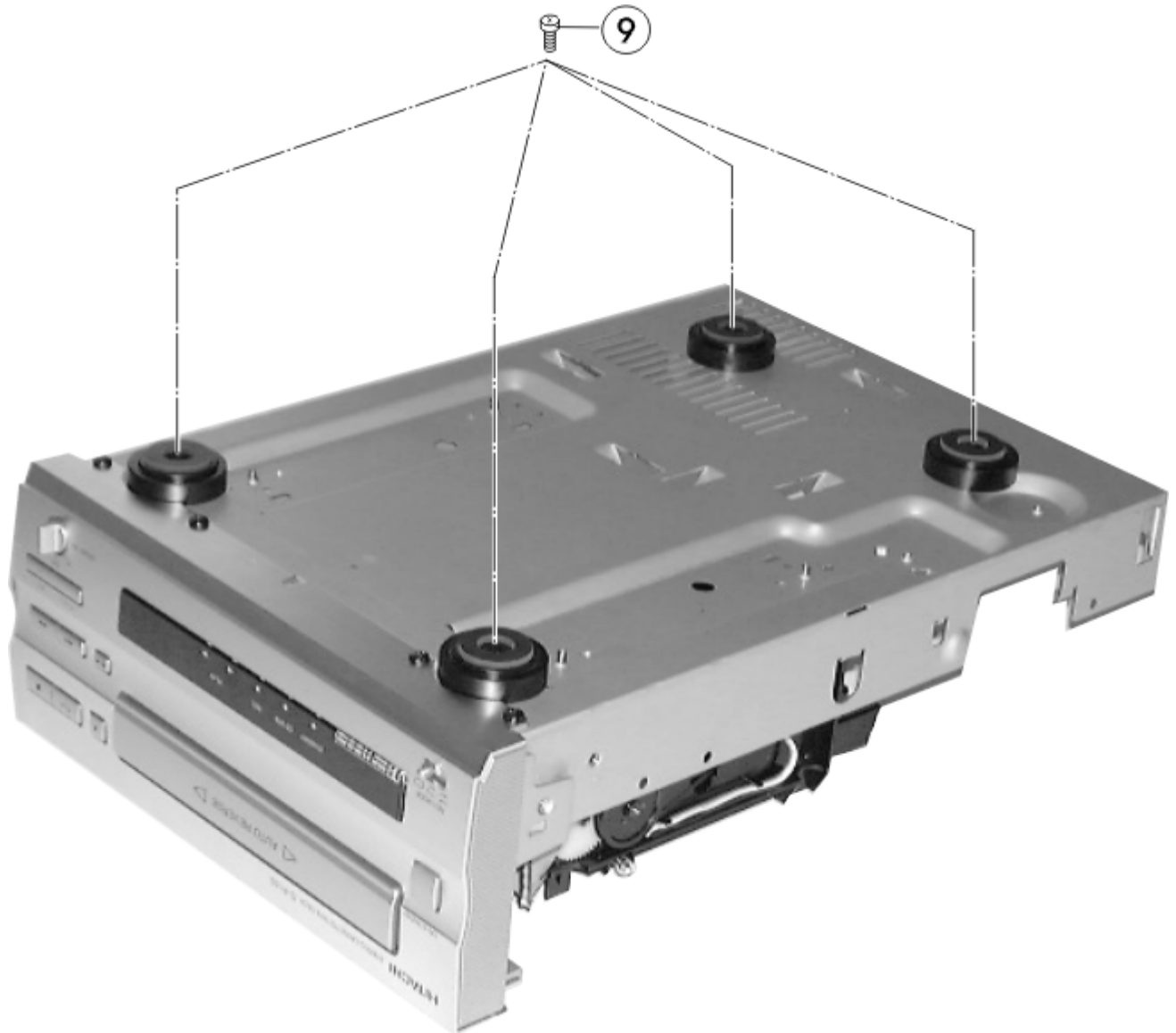

ADJUSTMENTS

Adjusting and Checking the Electrical Section

Measuring instruments needed for the adjustments

1. Low frequency oscillator
2. Variable resistance attenuator
3. Electronic voltmeter
4. Oscilloscope
5. Frequency counter
6. Adjustment screwdriver
7. Test tapes MTT-111, MTT-114N, MTT-150, Type1 tape (UD-1)
8. Mirror cassette for the transport (A-BEX TCC-902)

Adjustment precaution

1. Before adjustments, use gauze or a swab moistened with alcohol to wipe the surface of the heads, the capstan shaft, and the pinch roller.
2. Demagnetize the record/playback head and the erase head with a head eraser.
3. Completely demagnetize the driver to be used for the adjustments.
4. Unless otherwise specified, set the various operation controls as indicated below.

Dolby NR switch: Off

1. Tape transport check

Load the mirror cassette for the transport, and illuminate the area around the fixed guide of the record/playback head with a lamp and observe.

Check that the tape edge is not hitting the tape guide portion.

Note that the tape transport is the greatest factor affecting the performance of the cassette deck.

Never move the inspection locations without good reason.

2. Tape speed check and adjustment

1. Connect the frequency counter to the LINE OUT pin and load the test tape (MTT-111).
2. Playback FWD side of the test tape. At about halfway through the tape, where the tape transport is stable, confirm that the frequency counter will have a reading within the range of 3,000 Hz \pm 10 Hz.
3. Check REV side also that the counter reading indicates within 2955~3045Hz. Note: Adjust within 30 seconds, after pre-heating (Play) of 20 min, or more.

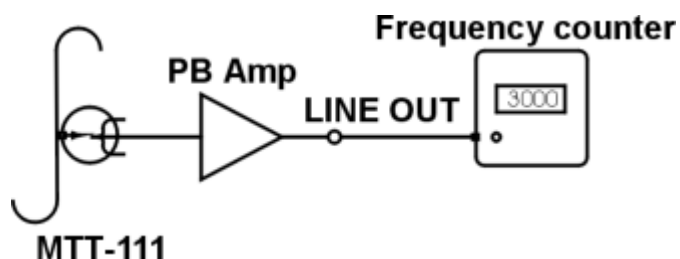

3. Azimuth Adjustment

1. Connect an electronic voltmeter to the Line Out terminal, and set Test tape MTT-114N into the Unit.
2. Playback FWD side, and adjust the azimuth screw A so as to get maximum indication on the voltmeter, then make the same adjustment with the screw B for REV side.
3. Readjust if the output level difference exceeds 2dB after adjustment, and also confirm that the phase difference in the both channels is within $\pm 45^\circ$.

Note: In order to prevent the backlash of the azimuth screw, end in the clockwise rotation.

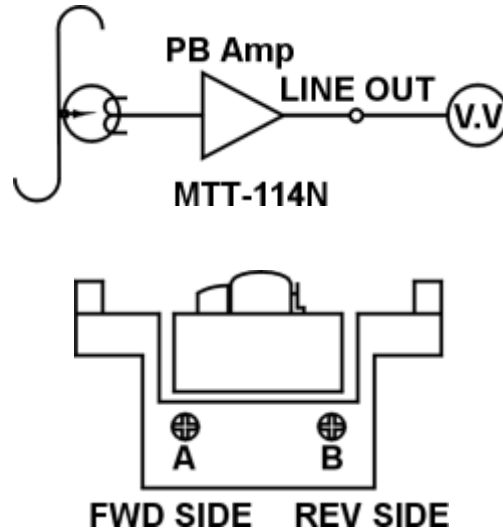

4. PB Output Level Adjustment

1. Connect an electronic voltmeter to the Line Out terminal, and set Test tape MTT-150 into the Unit.
2. Playback FWD side, and adjust the RT101L (Lch) and RT101R (Rch) so that the voltmeter indicates $400\text{mV} \pm 0.5\text{dB}$.

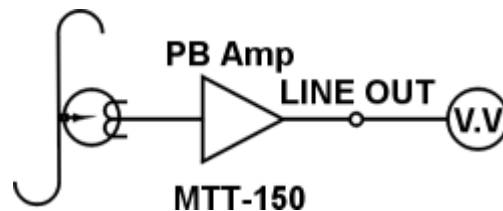

5. REC Level Adjustment

1. Set Test tape (Type 1 tape: UD-1) into the unit, input 400 Hz 94mV signal to JK1 LINE IN and record this signal on the tape.
2. Playback the recorded signal, and adjust RT102L (Lch) and RT102R (Rch) so that the voltmeter indicates $125\text{mV} \pm 0.5\text{dB}$ at JK1 LINE OUT.

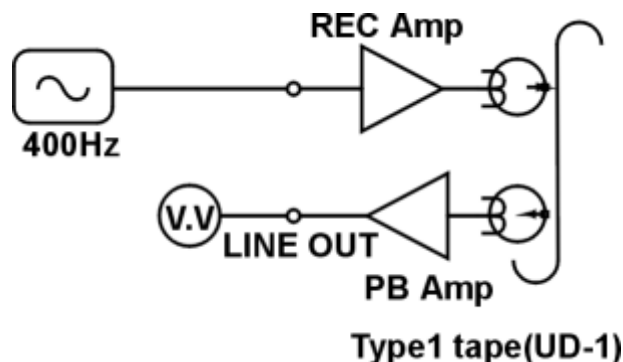

6. Bias Current Adjustment

1. Set Test tape (Type 1 tape: UD-1) into the unit, input 1.25 kHz/12.5 kHz 21mV signal to JK1 LINE IN and record this signal on the tape.
2. Playback the recorded signal, and adjust RT103L (Lch) and RT103R (Rch) so that the level difference between both frequencies becomes within the range of 28mV + 2dB ~ -0.5dB on the voltmeter at JK1 LINE OUT.

Remark: Unable to monitor waveform at line out during recording mode.

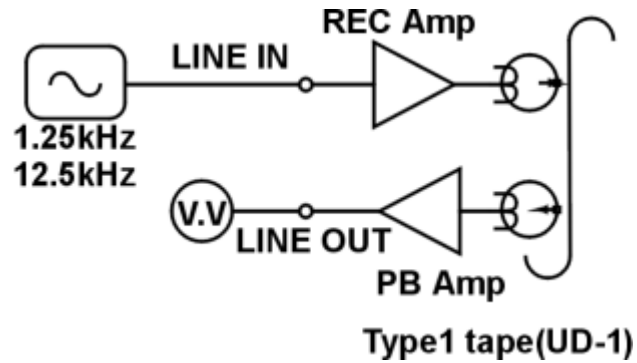

Adjustment Points

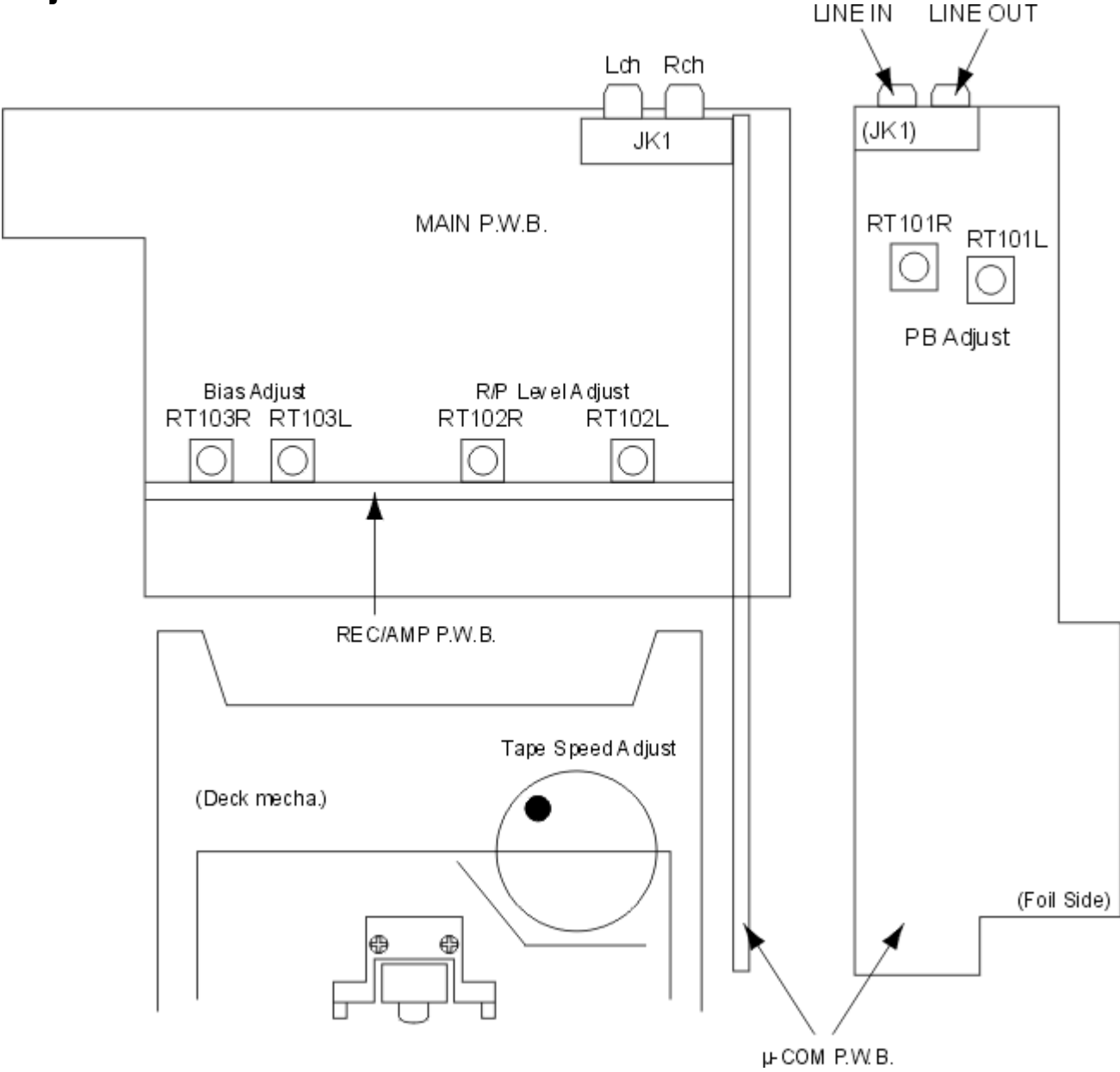

Wiring Diagram

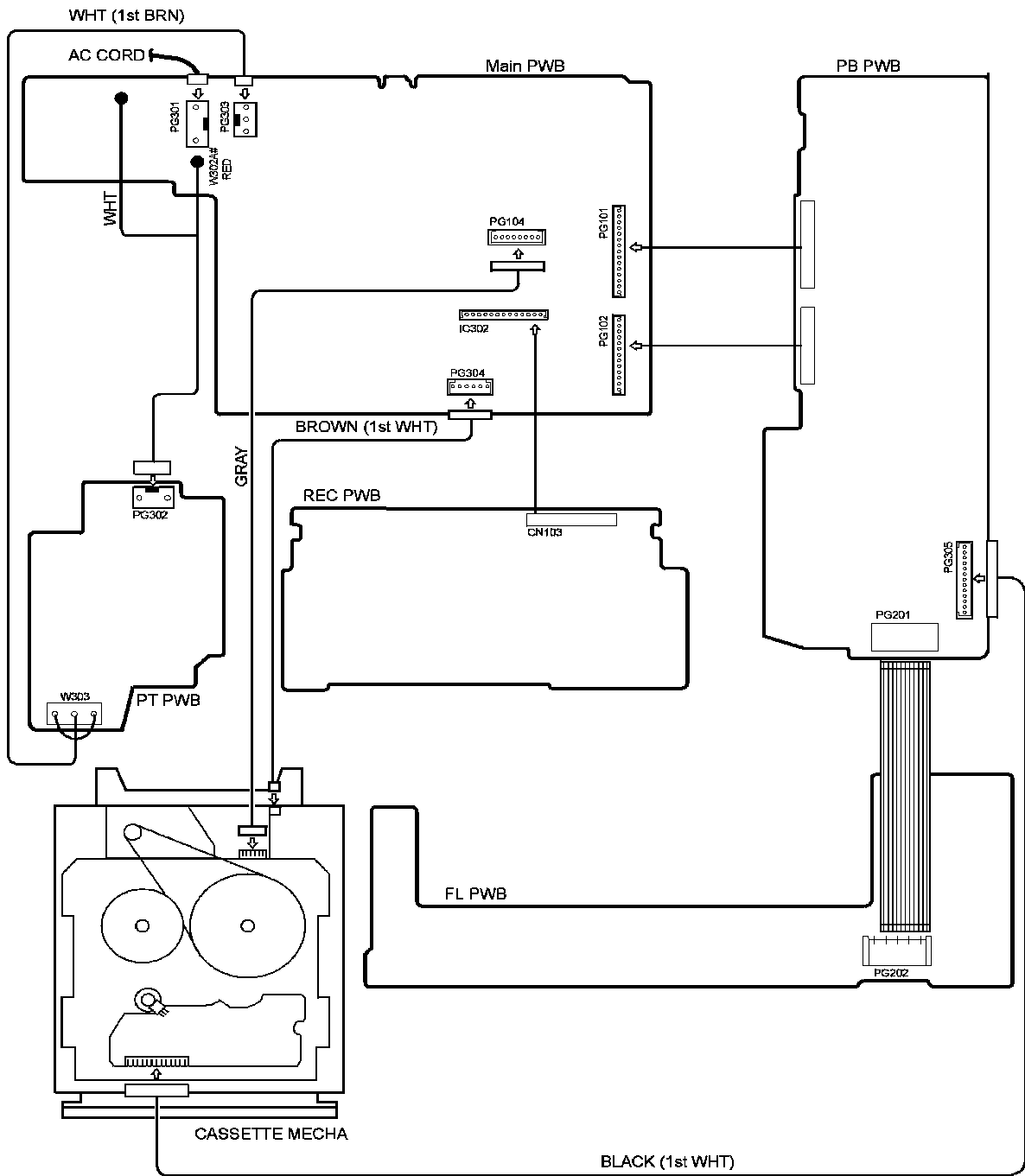

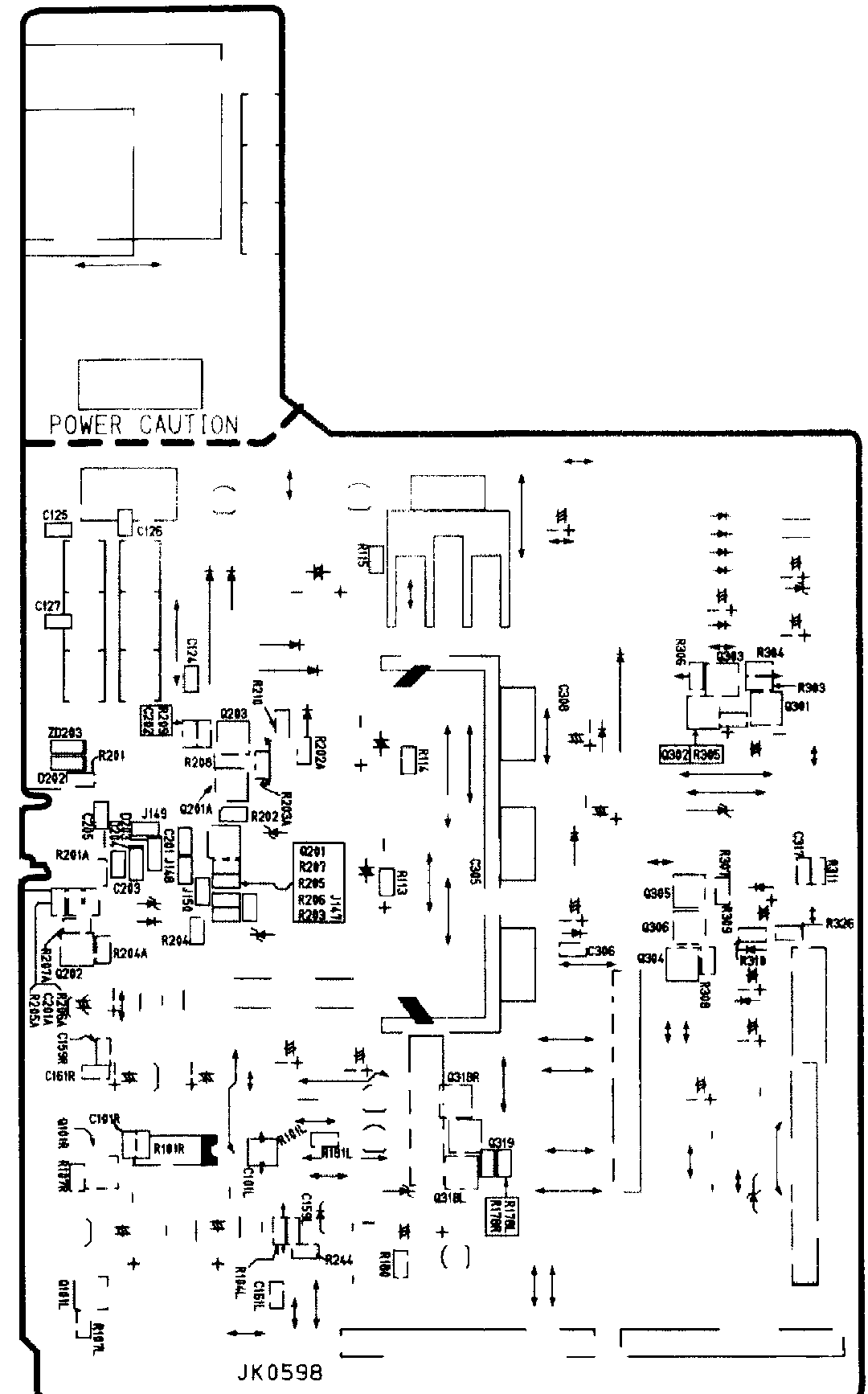
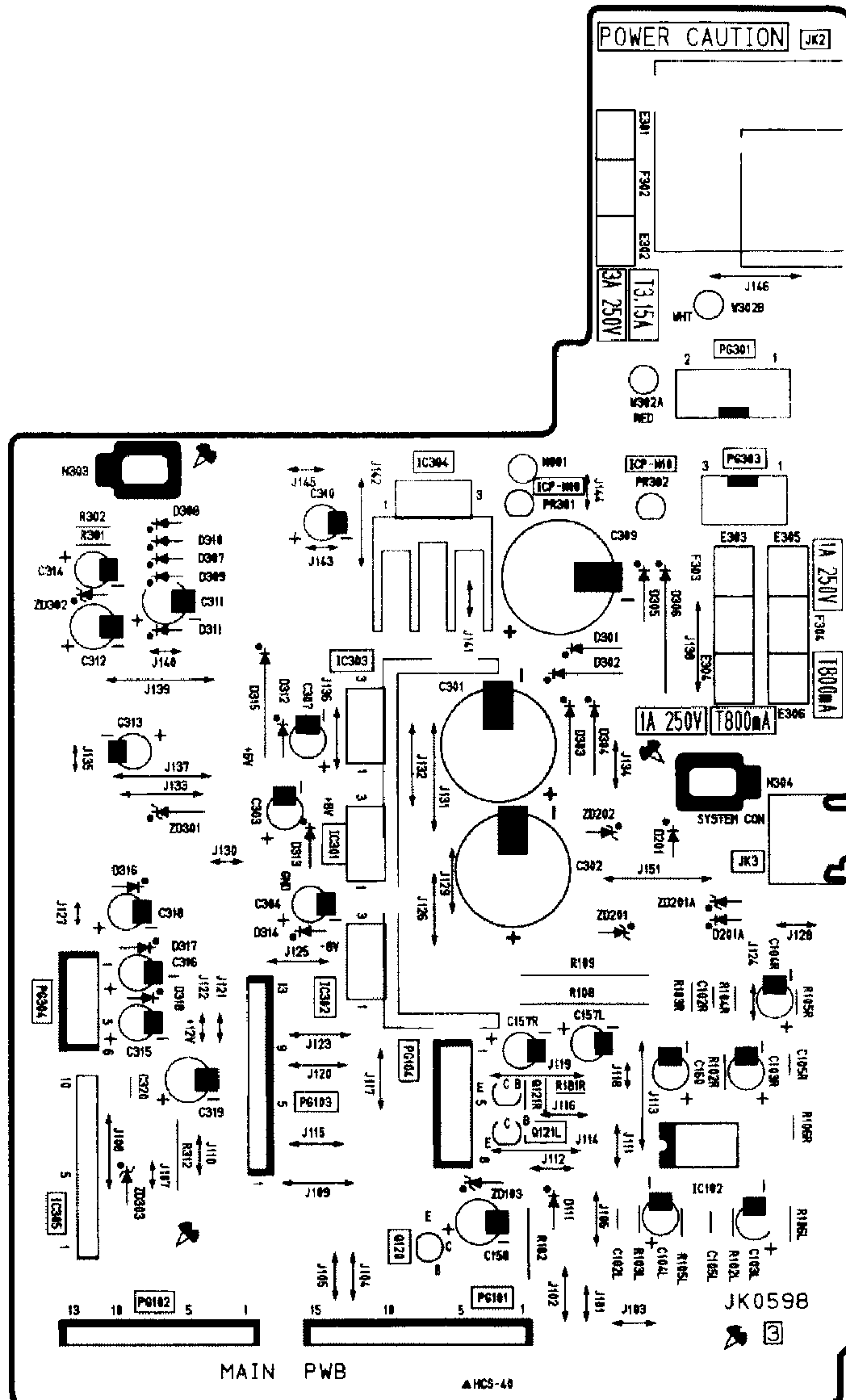

No 0093E

MAIN PWB

HITACHI

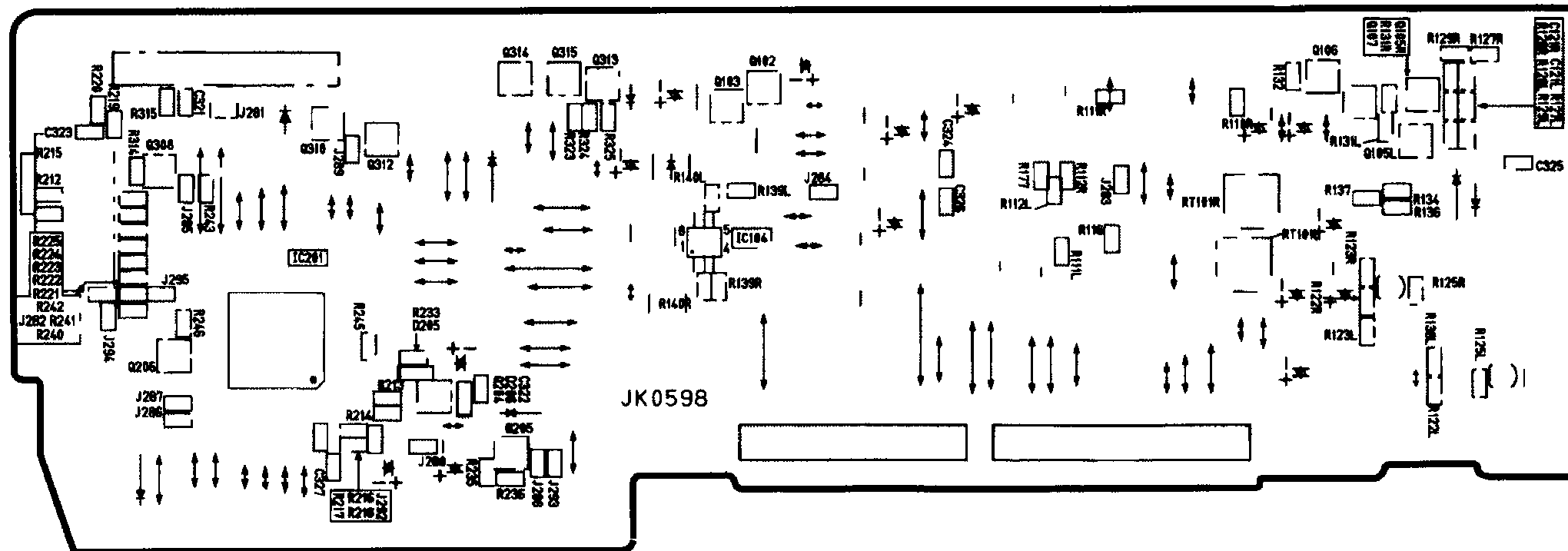
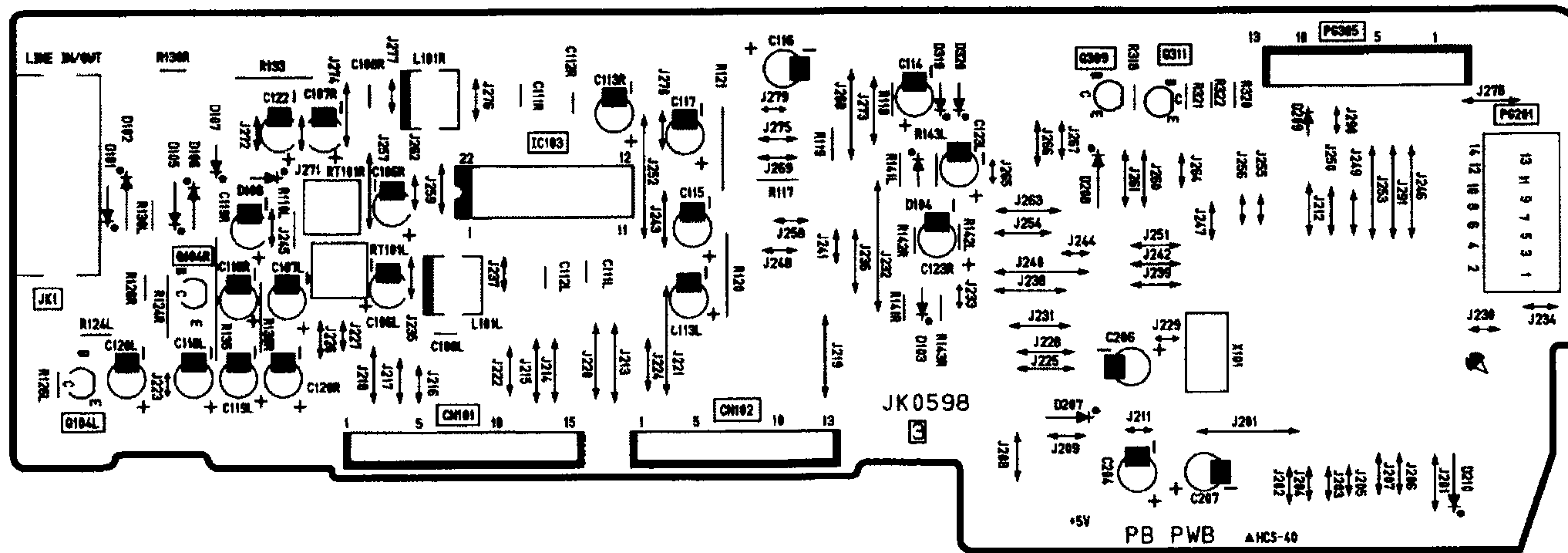

No 0093E

PB PWB

HITACHI

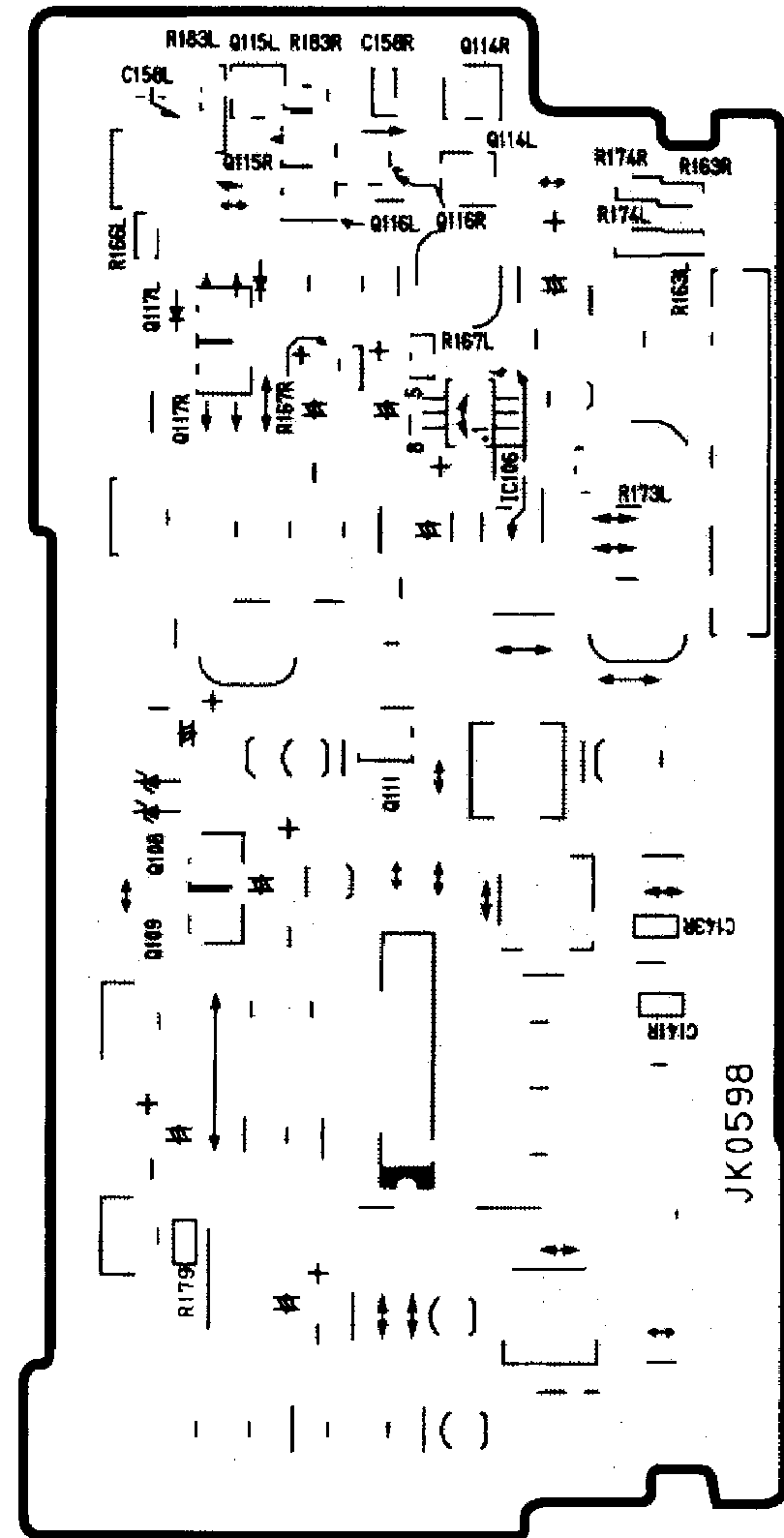
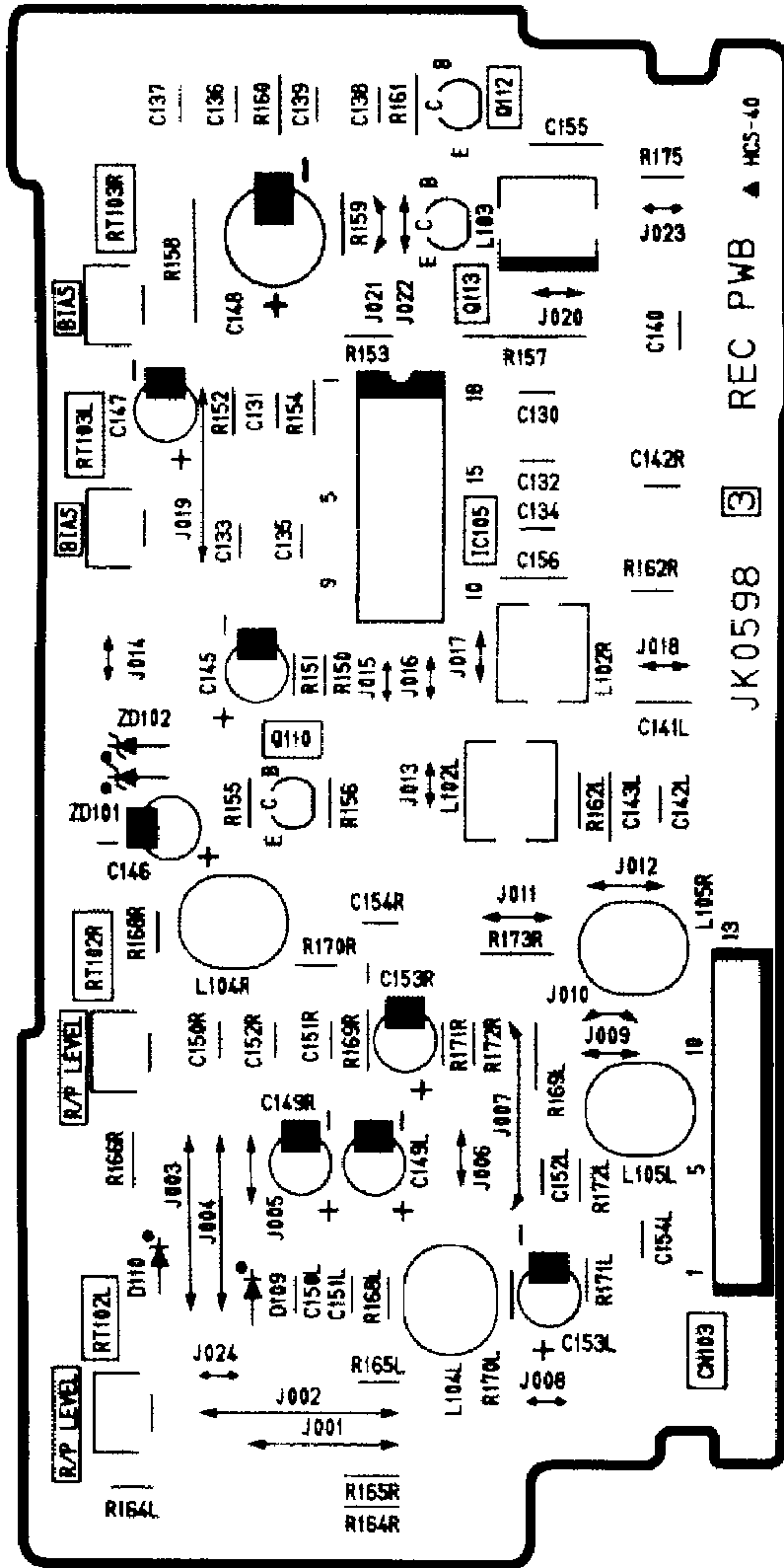

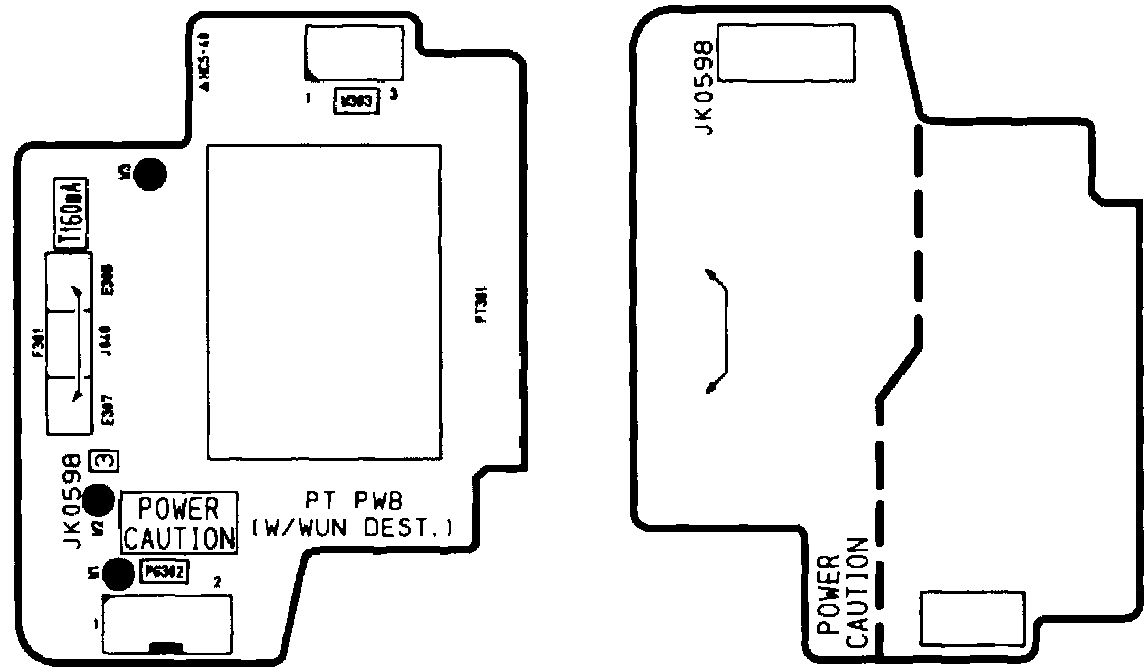

(W/WUN DEST)

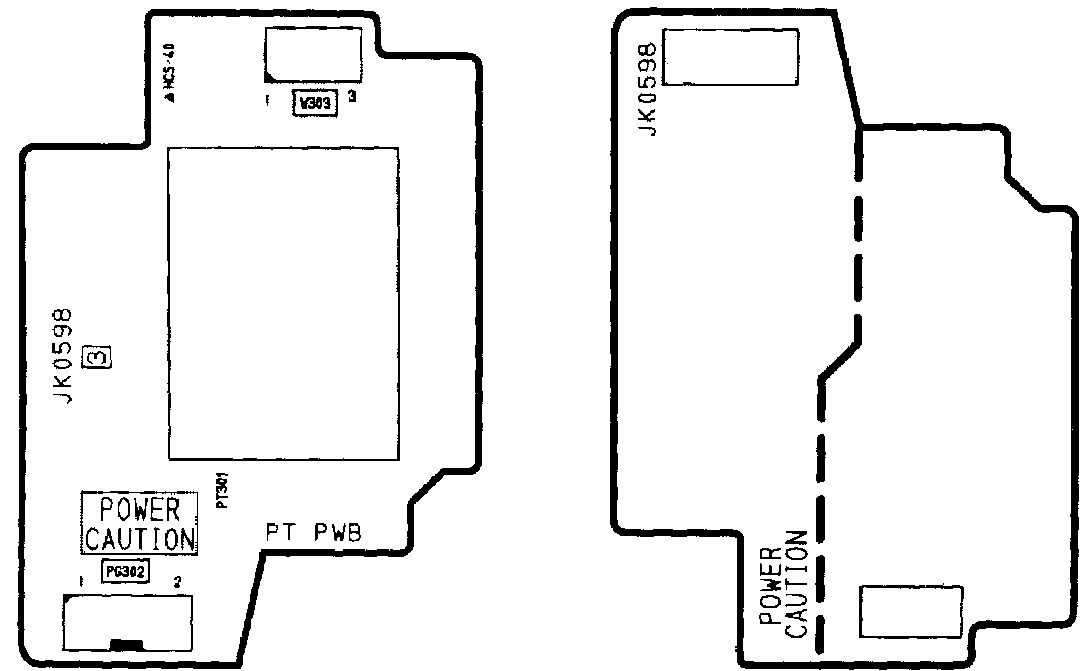

(UC, E, EBS DEST)

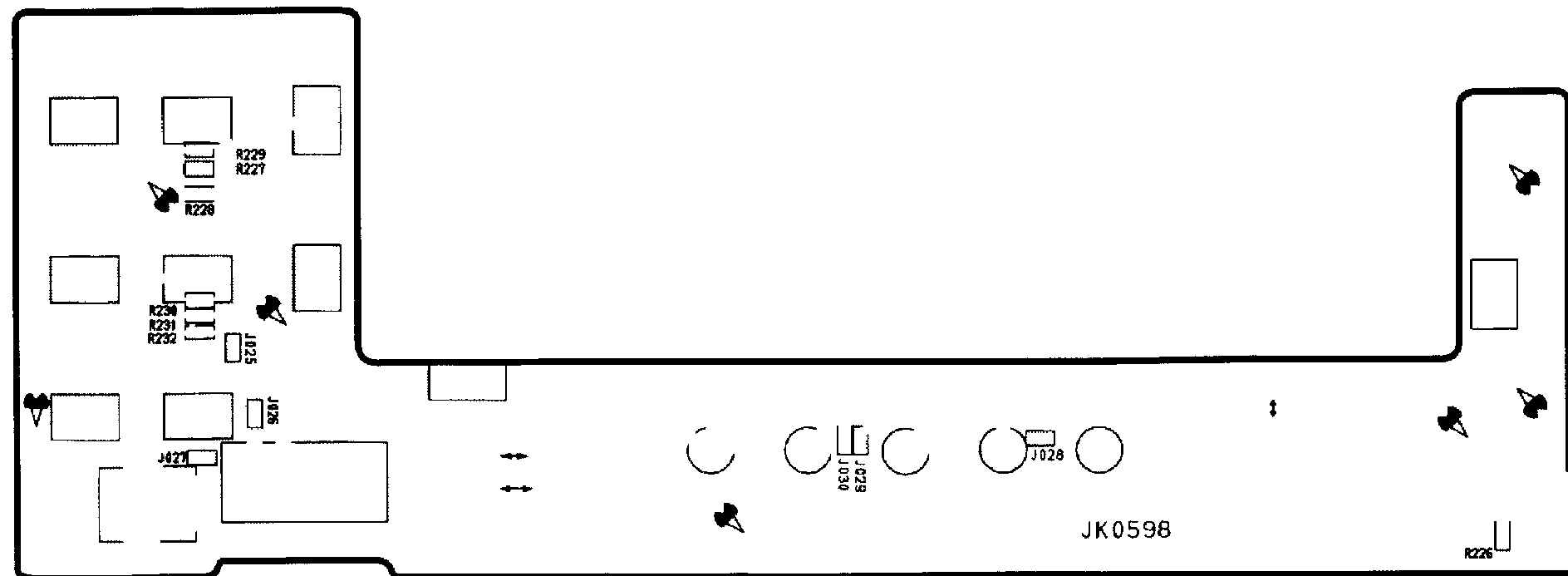
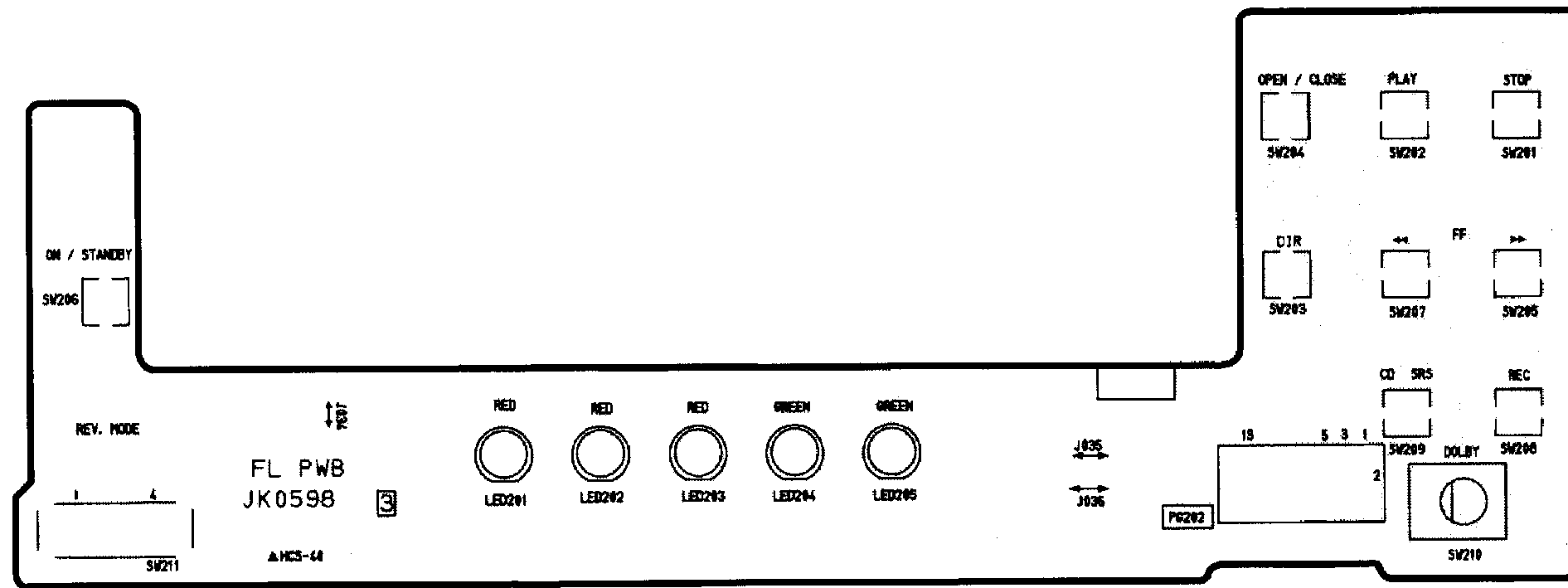

No 0093E

FL PWB

HITACHI

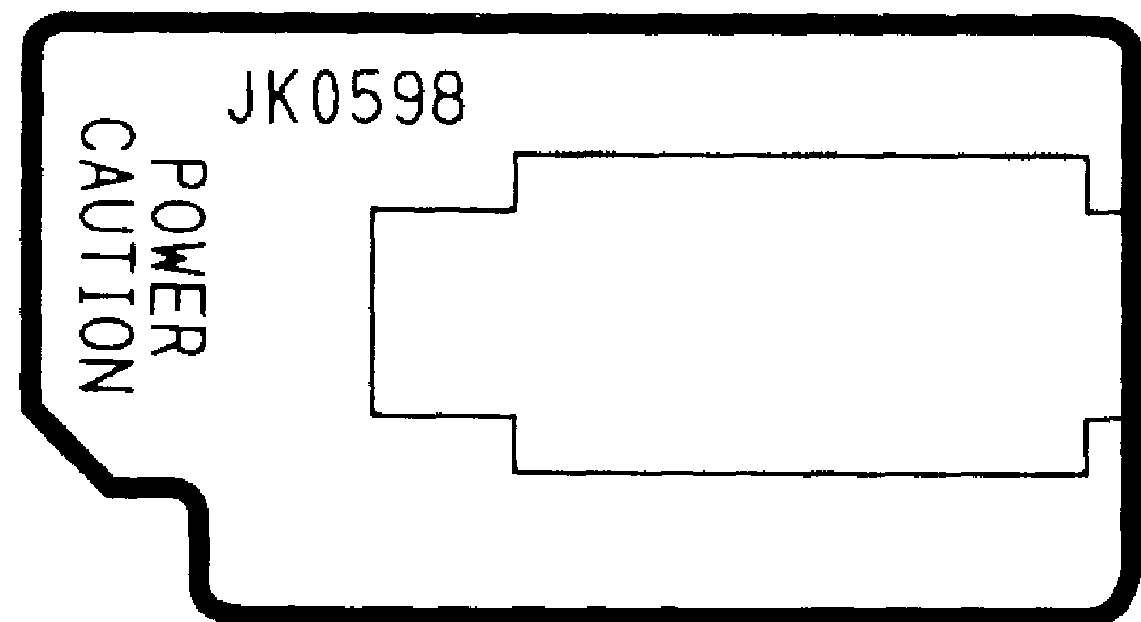
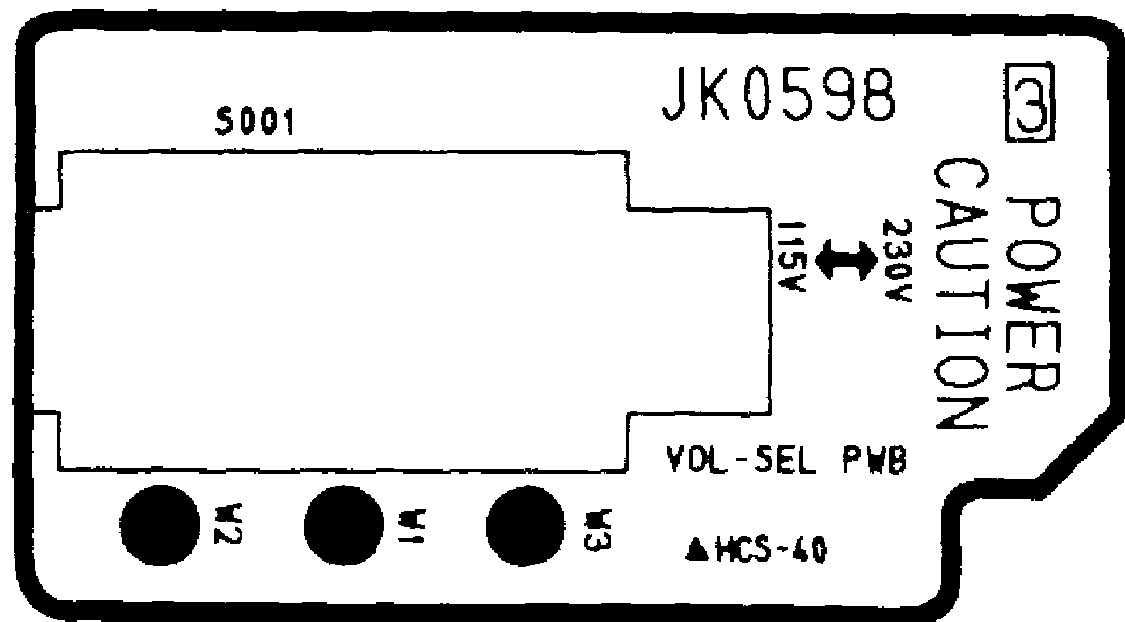

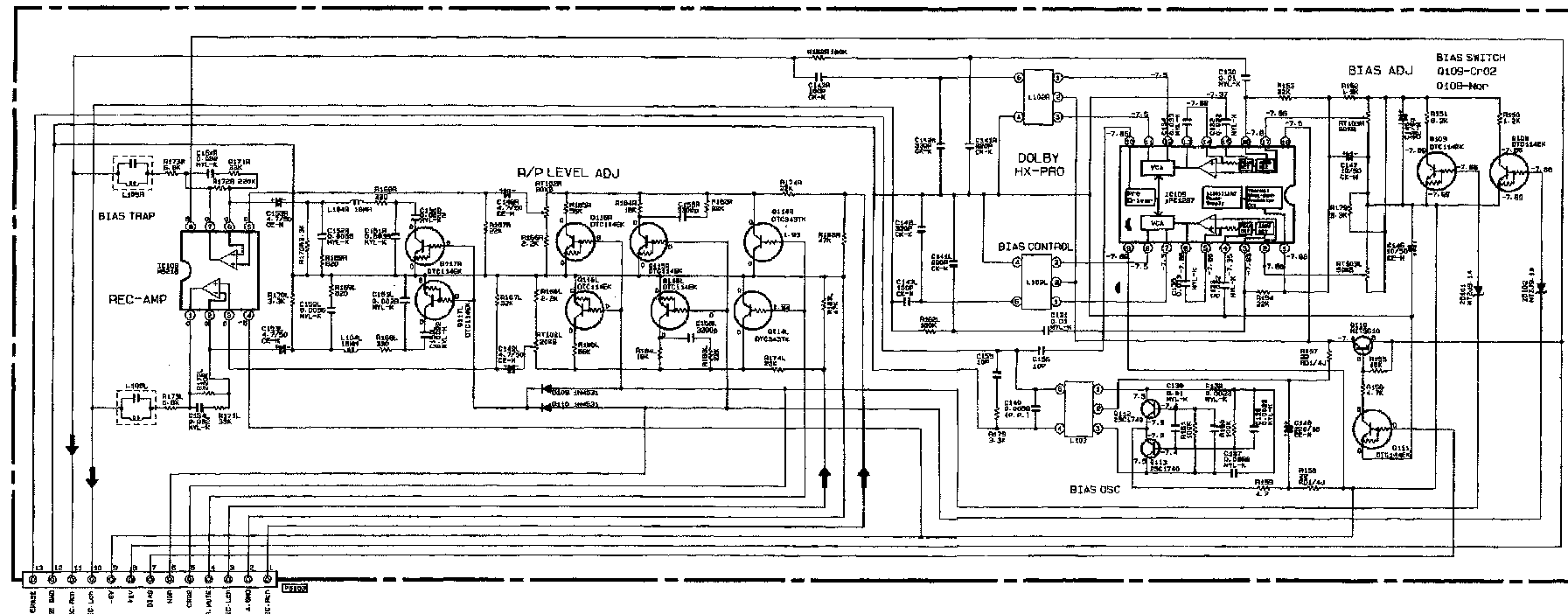

Symdo1	UC	E	EBS	W. WUN	J
F301	X	X	X	T160mA 250V	X
F302	3A 250V	T3.15A 250V	T3.15A 250V	X	3A 250V
F303	1A	T800mA 250V	T800mA 250V	T800mA 250V	1A
F304	1A	T800mA 250V	T800mA 250V	T800mA 250V	1A
PT301	BT00862	BT00863	BT00863	BT00864	BT00861
JK2	0	0	0	X	0
W1, W2	X	X	X	0	X
W3, S001	X	X	X	0	X
BLOCK A	X	X	X	X	X
BLOCK B	0	0	0	0	0

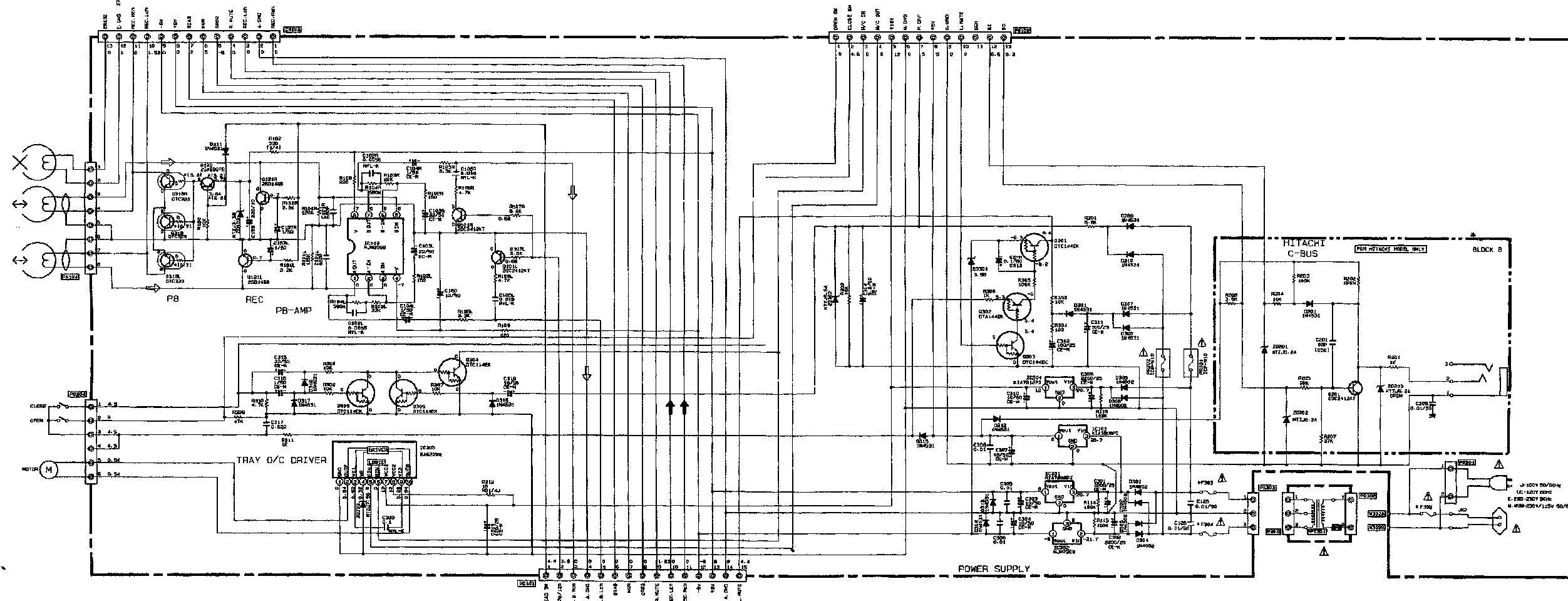
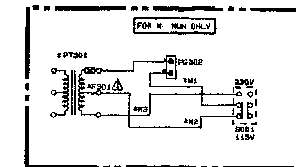

No 0093E

CIRCUIT DIAGRAM 1

HITACHI

INIT	ON	OFF
RECEIVE	RECEIVE	RECEIVE
RECORD	RECORD	RECORD
METAL	RECORD/METAL	METAL
MODE	RECORD	RECORD
HALF	0	0

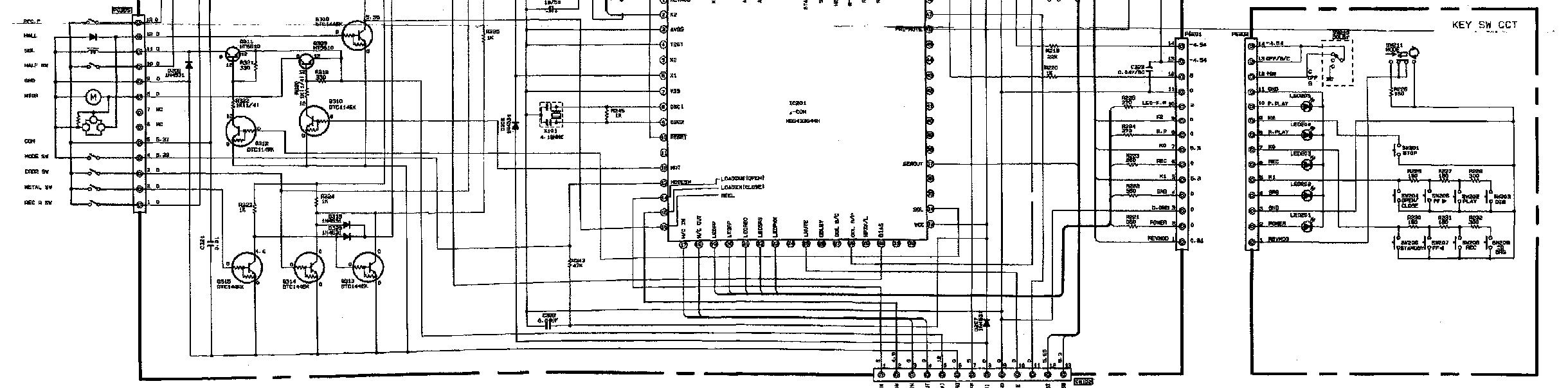

No 0093E

CIRCUIT DIAGRAM 2

HITACHI

Block Diagram

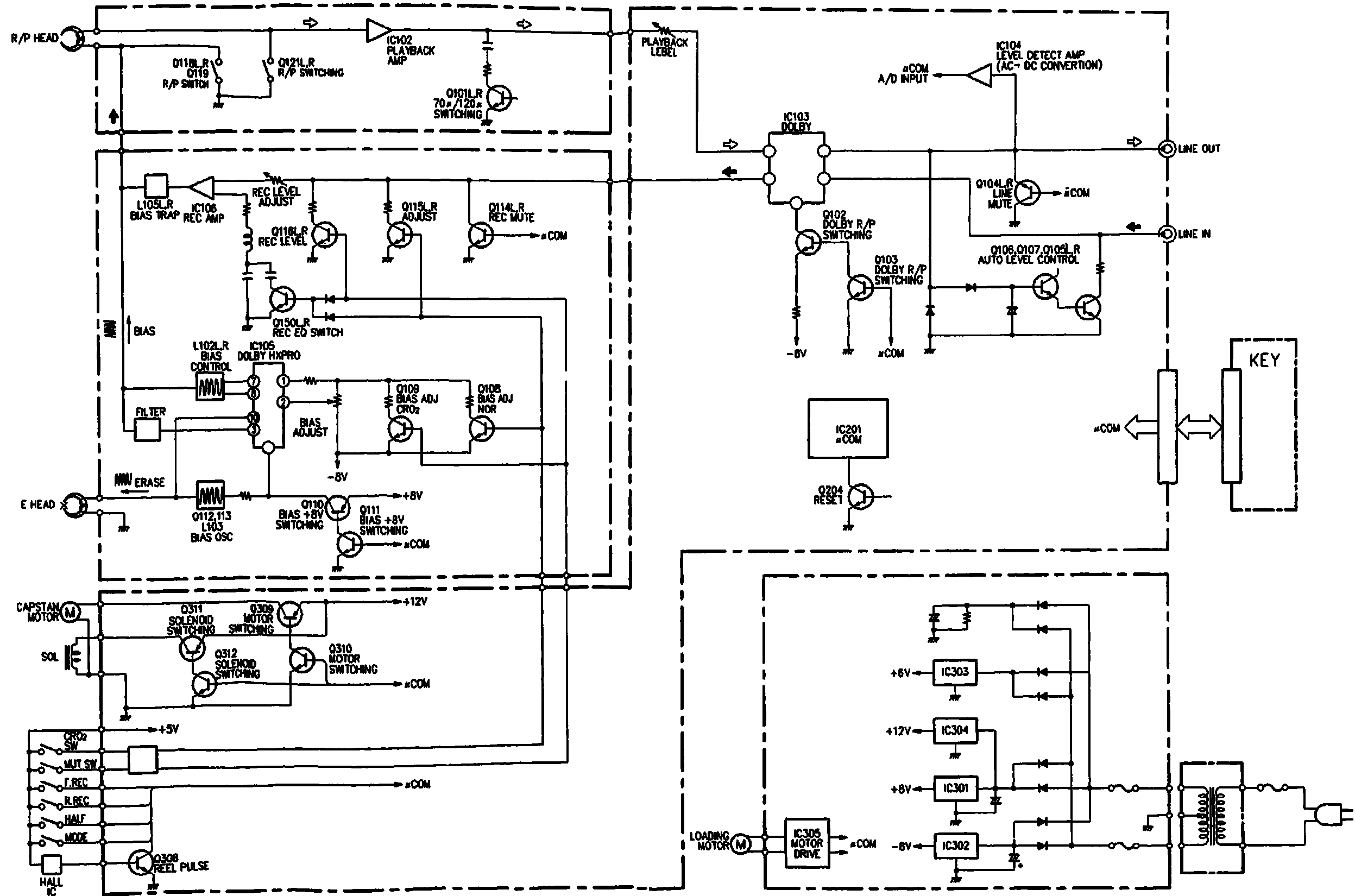

Exploded View

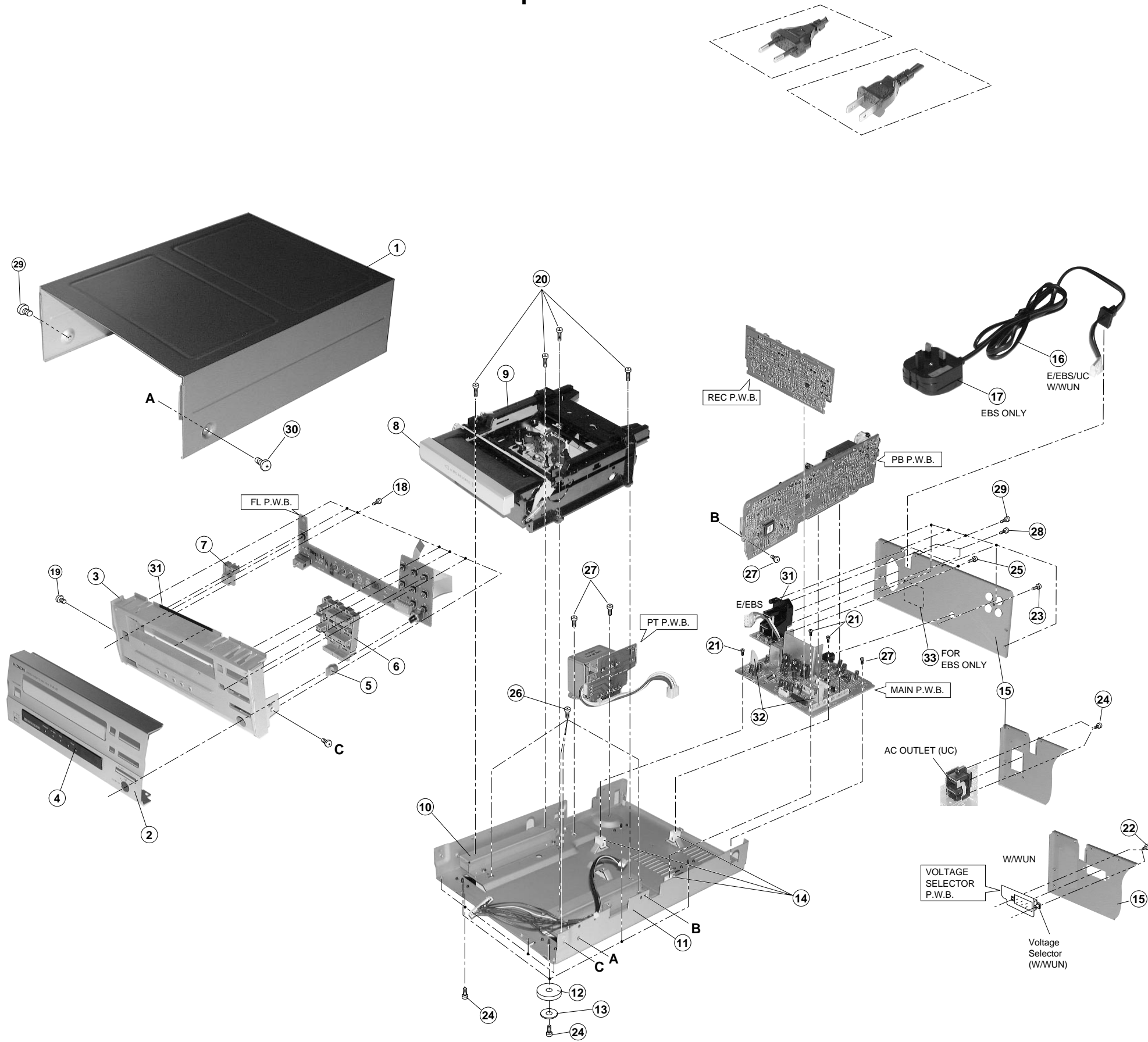

Cassette Chassis

- Nos. are reference Nos. of parts list

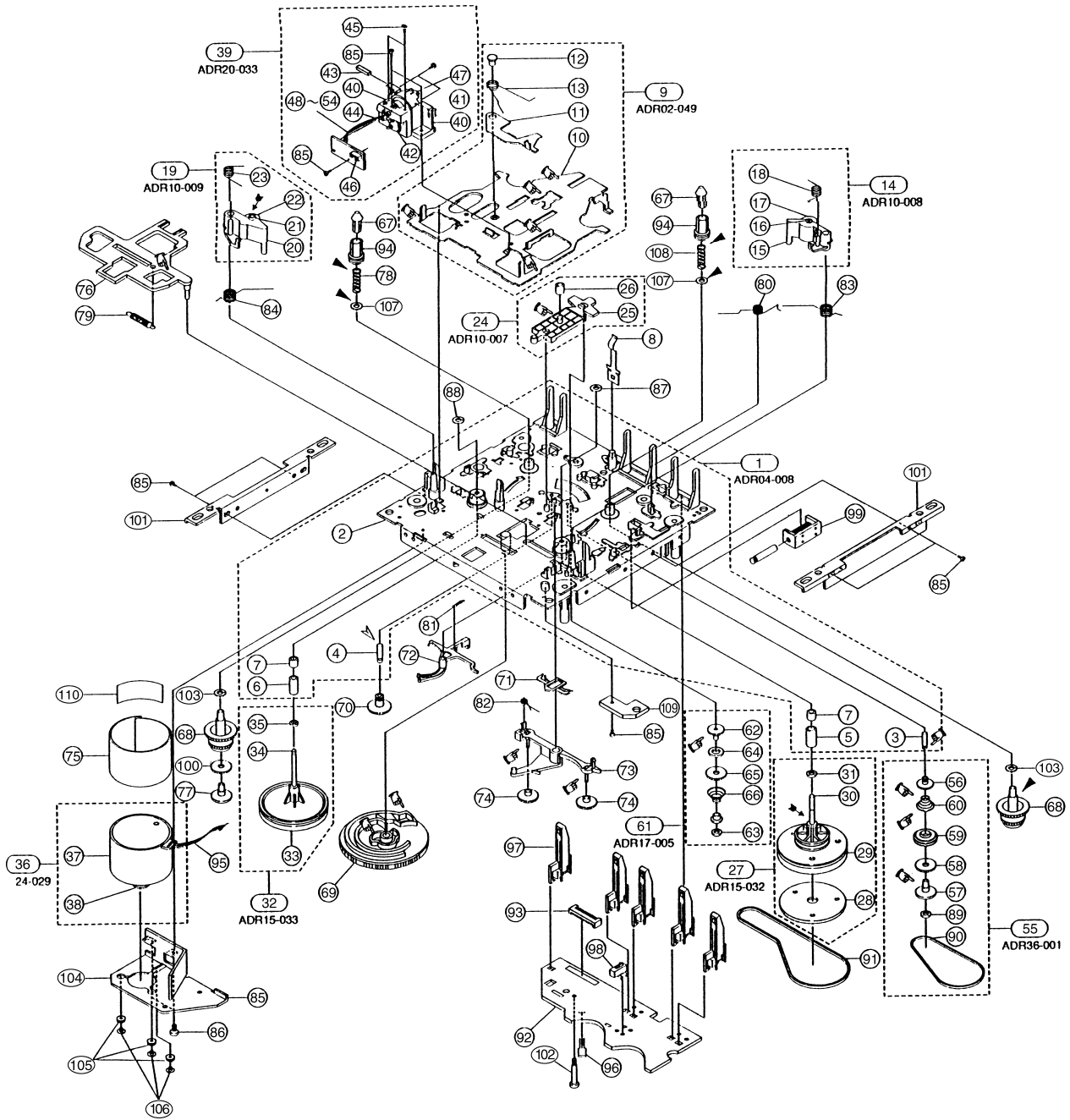

Cassette Loader Assembly

- Nos. are reference Nos. of parts list

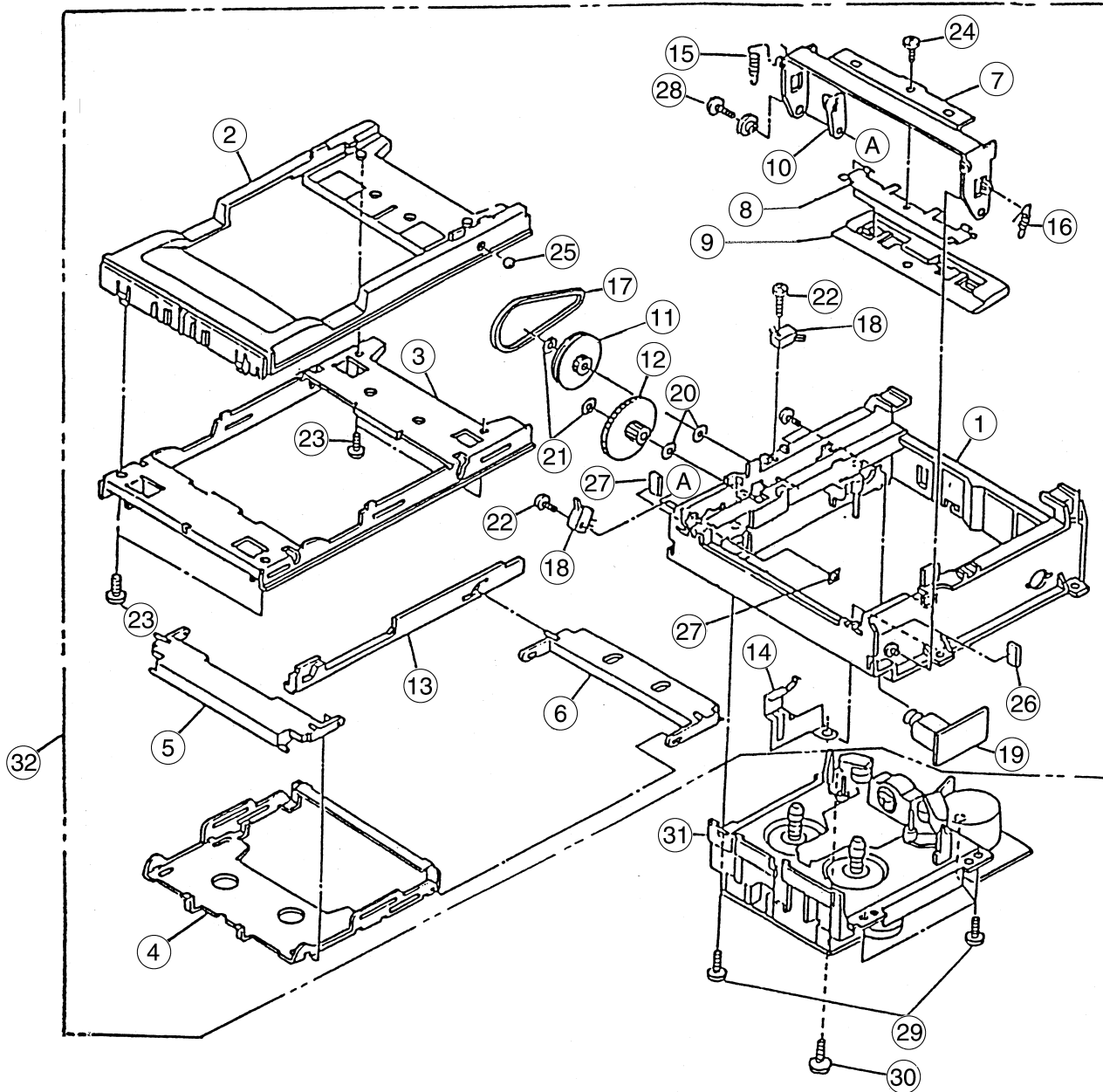

IC Data

Replacement Parts List

- Part indicated with the mark “}” are not always in stock and possibly to take along period of time for supplying, or in some case supplying of part may be refused.
- When ordering of part, clearly indicate “1” and “I” (i) to avoid mis-supplying.
- Ordering part without stating its part number can not be supplied.
- Part indicated with the mark “H” is not illustrated in the exploded view.
- Not including Carbon Film $\pm 5\%$, 1/4W Type in the P.W.Board parts list. (Refer to the Schematic Diagram for those parts.)

WARNING:

Parts marked with this symbol  have critical characteristics. Use ONLY replacement parts recommended by the manufacturer.

● Resistors

Ex.: RN Type 14K Shape and performance 2E Power 182 Resistance G Allowable error FR Others

RD : Carbon	2B : 1/8W	F : $\pm 1\%$	P : Pulse-resistance type
RC : Composition	2E : 1/4W	G : $\pm 2\%$	NL : Low noise type
RS : Metal oxide film	2H : 1/2W	J : $\pm 5\%$	NB : Non-burning type
RW : Winding	3A : 1W	K : $\pm 10\%$	FR : Fuse-resistor
RN : Metal film	3D : 2W	M : $\pm 20\%$	F : Lead wire forming
RK : Metal mixture	3F : 3W		
	3H : 5W		

* Resistors

1 8 2 \Rightarrow 1800 ohm = 1.8 kohm
 Indicates number of zeros after effective number.
 2-digit effective number.
 • Units: ohm

1 R 2 \Rightarrow 1.2 ohm
 1-digit effective number.
 2-digit effective number, decimal point indicated by R.
 • Units: ohm

● Capacitors

Ex.: CE Type 04W Shape and performance 1H Dielectric strength 2R2 Capacity M Allowable error BP Others

CE : Aluminium foil electrolytic	0J : 6.3V	F : $\pm 1\%$	HS : High stability type
CA : Aluminium solid electrolytic	1A : 10V	G : $\pm 2\%$	BP : Non-polar type
CS : Tantalum electrolytic	1C : 16V	J : $\pm 5\%$	HR : Ripple-resistant type
CQ : Film	1E : 25V	K : $\pm 10\%$	DL : For charge and discharge
CK : Ceramic	1V : 35V	M : $\pm 20\%$	HF : For assuring high frequency
CC : Ceramic	1H : 50V	Z : $+80\%$	U : UL part
CP : Oil	2A : 100V	-20%	C : CSA part
CM : Mica	2B : 125V	P : $+100\%$	W : UL-CSA type
CF : Metalized	2C : 160V	-0%	F : Lead wire forming
CH : Metalized	2D : 200V	C : $\pm 0.25\text{pF}$	
	2E : 250V	D : $\pm 0.5\text{pF}$	
	2H : 500V	= : Others	
	2J : 630V		

* Capacity (electrolyte only)

2 2 2 \Rightarrow 2200 μF
 Indicates number of zeros after effective number.
 2-digit effective number.
 • Units: μF

2 R 2 \Rightarrow 2.2 μF
 1-digit effective number.
 2-digit effective number, decimal point indicated by R.
 • Units: μF

* Capacity (except electrolyte)

2 2 2 \Rightarrow 2200pF=0.0022 μF
 (More than 2) Indicates number of zeros after effective number.
 2-digit effective number.
 • Units: pF

2 2 1 \Rightarrow 220pF
 (0 or 1) Indicates number of zeros after effective number.
 2-digit effective number.
 • Units: pF

• When the dielectric strength is indicated in AC, “AC” is included after the dielectric strength value.

• Transistors

HIT5610

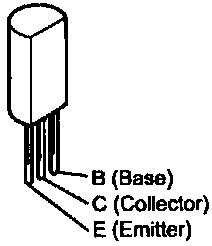

**2SA992FE
2SC1740
2SD1468**

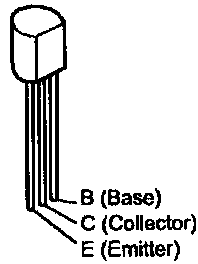

**DTA144EE
DTC114EK
DTC144EK
DTC323TK
DTC343TK
2SA1037AK(Q/R)
2SC2412KT**

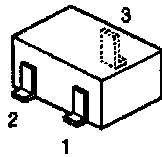

1: Emitter
2: Base
3: Collector

DTC EK/ES Series

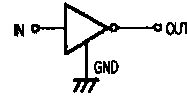
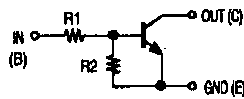

	R1	R2
DTC114EK	10 kohm	10 kohm
DTC144EK	47 kohm	47 kohm

DTC TK/TS Series

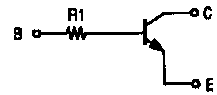

	R1
DTC323TK	2.2 kohm
DTC343TK	4.7 kohm

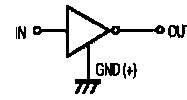
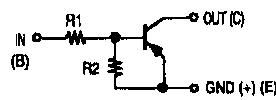

	R1	R2
DTA144EE	47 kohm	47 kohm

• DIODE

**MTZJ9.1A
MTZJ3.3B
MTZJ6.2A
MTZJ3.9B
MTZJ5.6A
MTZJ7.5B**

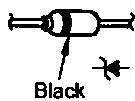

1N4531

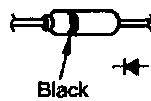

1SS133

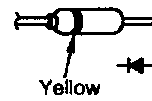

1N4002

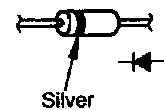

CXA1561S (IC103)

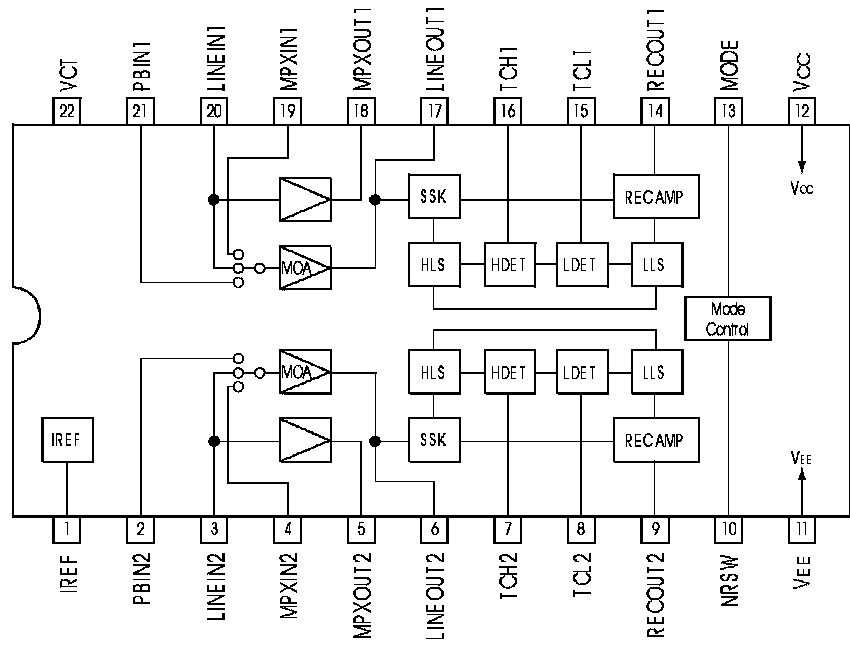
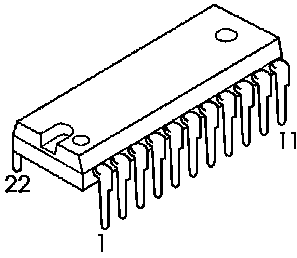

BA6209N (IC305)

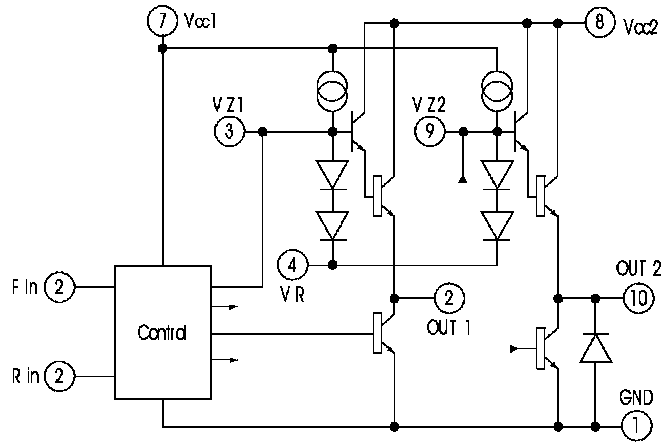
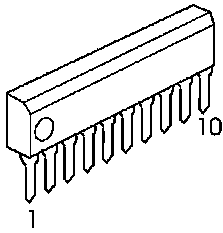

**μPC1297CA (IC105)
DOLBY HX-PRO**

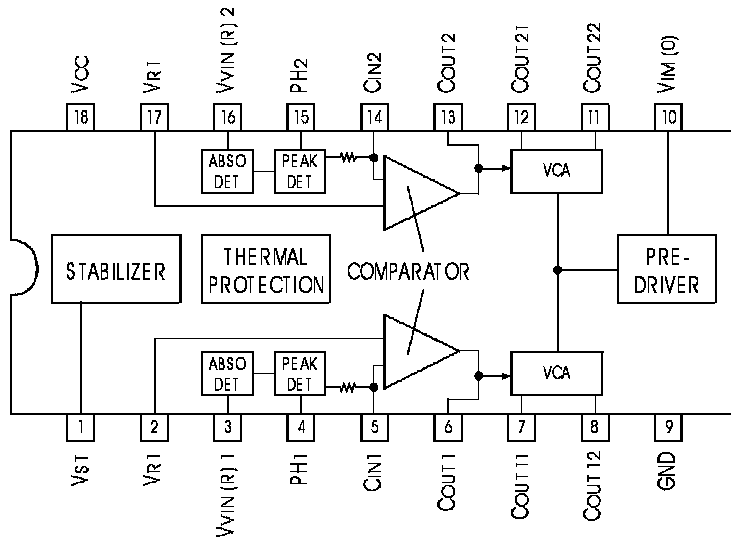
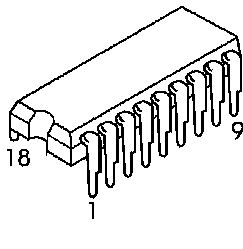

NJM2068 (IC102)

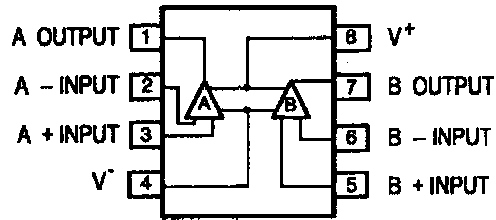
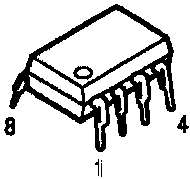

NJM7908 (IC302)

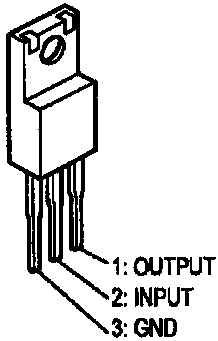

**KIA7806PI (IC303)
KIA7808PI (IC301)
KIA7812PI (IC304)**

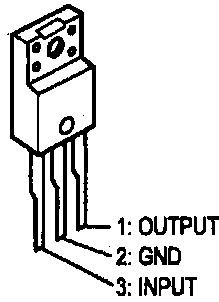

M5218AFP (IC104,106)

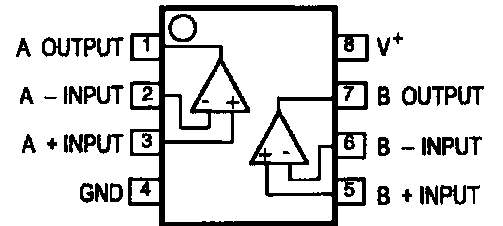
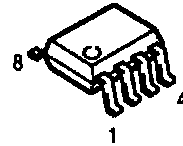

**● IC PROTECTOR
ICP-N10 (PR301,PR302)**

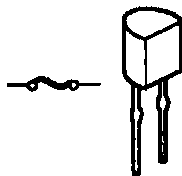

**● LED
SLR56VC3F (LED201~203)(Red)
SLR56MC3F (LED204~205)(Green)**

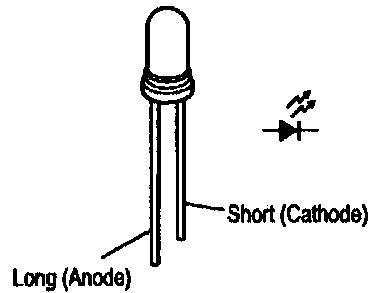

**THE UPDATED PARTS LIST
FOR THIS MODEL IS
AVAILABLE ON ESTA**

HITACHI

Hitachi, Ltd. Tokyo, Japan
International Sales Division
THE HITACHI ATAGO BUILDING,
No. 15-12 Nishi Shinbashi, 2 - Chome,
Minato - Ku, Tokyo 105-8430, Japan.
Tel: 03 35022111

HITACHI EUROPE LTD,

Whitebrook Park
Lower Cookham Road
Maidenhead
Berkshire
SL6 8YA

UNITED KINGDOM

Tel: 01628 643000
Fax: 01628 643400
Email: consumer-service@hitachi-eu.com

HITACHI EUROPE S.A.

364 Kifissias Ave. & 1, Delfon Str.
152 33 Chalandri
Athens

GREECE

Tel: 1-6837200
Fax: 1-6835964
Email: service.hellas@hitachi-eu.com

HITACHI EUROPE GmbH

Munich Office
Dornacher Strasse 3
D-85622 Feldkirchen bei München

GERMANY

Tel: +49-89-991 80-0
Fax: +49-89-991 80-224
Hotline: +49-180-551 25 51 (12ct/min)
Email: HSE-DUS.service@hitachi-eu.com

HITACHI EUROPE S.A.

Gran Via Carlos III, 101-1
08028 Barcelona

SPAIN

Tel: 93 409 2550
Fax: 93 491 3513
Email: atencion.cliente@hitachi-eu.com

HITACHI EUROPE srl

Via Tommaso Gulli N.39, 20147
Milano, Italia

ITALY

Tel: +39 02 487861
Tel: +39 02 38073415 Servizio Clienti
Fax: +39 02 48786381/2
Email: customerservice.italy@hitachi-eu.com

HITACHI Europe AB

Box 77 S-164 94 Kista

SWEDEN

Tel: +46 (0) 8 562 711 00
Fax: +46 (0) 8 562 711 13
Email: csgswe@hitachi-eu.com

HITACHI EUROPE S.A.S

Lyon Office
B.P. 45, 69671 BRON CEDEX

FRANCE

Tel: 04 72 14 29 70
Fax: 04 72 14 29 99
Email: france.consommateur@hitachi-eu.com

HITACHI EUROPE LTD (Norway) AB

STRANDVEIEN 18

1366 Lysaker

NORWAY

Tel: 67 5190 30
Fax: 67 5190 32
Email: csgnor@hitachi-eu.com

HITACH EUROPE AB

Egebækgård
Egebækvej 98
DK-2850 Nærum

DENMARK

Tel: +45 43 43 6050
Fax: +45 43 60 51
Email: csgnor@hitachi-eu.com

HITACHI EUROPE AB

Neopoli / Niemenkatu 73
FIN-15140 Lahti

FINLAND

Tel : +358 3 8858 271
Fax: +358 3 8858 272
Email: csgnor@hitachi-eu.com

Hitachi Europe Ltd

Bergensesteenweg 421
1600 Sint-Pieters-Leeuw

BELGIUM

Tel: +32 2 363 99 01
Fax: +32 2 363 99 00
Email: sofie.van.bom@hitachi-eu.com

HITACHI EUROPE LTD

Na Sychrove 975/8
101 27 Praha 10 - Bohdalec

CZECH REPUBLIC

Tel: +420 267 212 383
Fax: +420 267 212 385
Email: csgnor@hitachi-eu.com

www.hitachidigitalmedia.com