

**KEY TO ILLUSTRATIONS**

- ① POWER SWITCH
- ② EJECT BUTTON
- ③ OPERATION BUTTONS
- ④ TAPE COUNTER / RESET BUTTON
- ⑤ PEAK LEVEL INDICATOR
- ⑥ DOLBY NR SWITCH
- ⑦ DOLBY NR B/C SELECT SWITCH
- ⑧ HEADPHONE JACK
- ⑨ MICROPHONE JACKS
- ⑩ MULTI-REPEAT BUTTON
- ⑪ PROGRAM MEMORY BUTTON
- ⑫ SCANPLAY BUTTON
- ⑬ RECORDING LEVEL CONTROL KNOB
- ⑭ REC MUTE BUTTON
- ⑮ MODE SELECTOR
- ⑯ MODE INDICATOR
- ⑰ TIMER SWITCH

**Regler und Bedienungselemente**

- ① Netzschalter
- ② Cassettenauswurf-taste
- ③ Funktionstasten
- ④ Bandzählwerk/Rückstellknopf
- ⑤ Spitzenwertanzeige
- ⑥ Dolby-NR-Schalter
- ⑦ Dolby-NR-B/C-Wahlschalter
- ⑧ Kopfhörerbuchse
- ⑨ Mikrofonbuchse
- ⑩ Multi-Repeat-Taste
- ⑪ Programmspeichertaste
- ⑫ Scanplay-Taste
- ⑬ Aufnahmepegelregler
- ⑭ REC-Mute-Taste
- ⑮ Betriebsartenwähler
- ⑯ Laufanzeige
- ⑰ Zeitschalter

**Guide des illustrations**

- ① Interrupteur d'alimentation
- ② Touche d'éjection de cassette
- ③ Touches d'opération
- ④ Compteur de bande/poussoir de remise à zéro
- ⑤ Indicateur de niveau de crête
- ⑥ Interrupteur de réducteur de bruit Dolby
- ⑦ Sélecteur de circuit Dolby B/C
- ⑧ Prise pour casque d'écoute
- ⑨ Prise de microphone
- ⑩ Touche de répétition multiple
- ⑪ Touche de mémorisation de programme
- ⑫ Touche de recherche et lecture
- ⑬ Réglage de niveau d'enregistrement
- ⑭ Touche de sourdine à l'enregistrement
- ⑮ Sélecteur de mode
- ⑯ Témoin de mode de défilement
- ⑰ Interrupteur de minuterie

**CONTENTS**

- KEY TO ILLUSTRATIONS . . . . . 2
- SPECIFICATIONS . . . . . 2
- FEATURES . . . . . 4
- MAJOR FUNCTIONS AND HANDLING METHOD . . . . . 5
- DISASSEMBLY . . . . . 8
- ADJUSTMENTS . . . . . 12
- LUBRICATION . . . . . 21
- DESCRIPTION OF NEW PARTS . . . . . 22
- DESCRIPTION OF NEW MECHANISM . . . . . 35
- DESCRIPTION OF NEW CIRCUIT . . . . . 41
- BLOCK DIAGRAM . . . . . 42
- PRINTED WIRING BOARD . . . . . 43
- CIRCUIT DIAGRAM . . . . . 45
- WIRING DIAGRAM . . . . . 47
- EXPLODED VIEW . . . . . 49
- REPLACEMENT PARTS LIST . . . . . 53

**INHALTSVERZEICHNIS**

- REGLER UND BEDIENUNGSELEMENTE . . . . . 2
- TECHNISCHE DATEN . . . . . 3
- MERKMALE . . . . . 4
- HAUPTFUNKTIONEN UND HANDHABUNG . . . . . 6
- DEMONTAGE . . . . . 10
- EINSTELLUNGEN . . . . . 15
- SCHMIERUNG . . . . . 21
- BESCHREIBUNG DER NEUEN TEILE . . . . . 22
- BESCHREIBUNG DES NEUEN MECHANISMUS . . . . . 37
- BESCHREIBUNG DES NEUEN STROMKREISES . . . . . 41
- BLOCKSCHEMA . . . . . 42
- PRINTPLATTEN . . . . . 43
- SCHALTPLAN . . . . . 45
- VERDRAHTUNGSSCHEME . . . . . 47
- EXPLOSIONANSICHT . . . . . 49
- ERSATZTEILLISTE . . . . . 53

**TABLE DES MATIÈRES**

- GUIDE DES ILLUSTRATIONS . . . . . 2
- FICHE TECHNIQUE . . . . . 3
- CARACTÉRISTIQUES . . . . . 4
- FONCTIONS PRINCIPALES ET MÉTHODE D'UTILISATION . . . . . 7
- DÉMONTAGE . . . . . 11
- MÉTHODES DE RÉGLAGE . . . . . 18
- LUBRIFICATION . . . . . 21
- DESCRIPTION DES NOUVELLES PIÈCES . . . . . 22
- DESCRIPTION DES NOUVEAUX MÉCANISMES . . . . . 39
- DESCRIPTION DES NOUVEAUX CIRCUITS . . . . . 41
- SCHÉMA . . . . . 42
- PLAN DE BASE . . . . . 43
- PLAN DE CIRCUIT . . . . . 45
- SCHÉMA DE CÂBLAGE . . . . . 47
- VUE EXPLOSEE . . . . . 49
- TABLEAU DES PIÈCES . . . . . 53

**SAFETY PRECAUTIONS**

The following precautions should be observed when servicing.

- Since many parts in the unit have special safety related characteristics, always use genuine Hitachi's replacement parts. Especially critical parts in the power circuit block should not be replaced with other makers. Critical parts are marked with  $\Delta$  in the circuit diagram.
- Before returning a repaired unit to the customer, the service technician must thoroughly test the unit to ascertain that it is completely safe to operate without danger of electrical shock.

**SPECIFICATIONS**

Track System:	4 track 2 channel stereo	Wow and Flutter:	0.04% (WRMS)
Tape:	Cassette tape		0.13% (According to DIN 45 500)
Tape Speed:	4.75 cm/s	Input Sensitivity and Impedance:	Microphone: 0.54 mV (Suitable Microphone impedance 300 ohms to 5 kohms)
Recording system and Bias Frequency:	AC bias, 85 kHz		Line in; 97 mV 50 kohms or more
Erasing System:	AC erase	Output Level: Output Load Impedance:	500 mV
Erase Ratio:	65 dB (at 1 kHz) or more		Line out: 50 kohms or more
Frequency Response:	NOR-I: 20 Hz to 16 kHz 40 Hz to 14 kHz (According to DIN 45 500)		Headphone: 8 ohms to 2 kohms (Suitable)
	CrO <sub>2</sub> -II: 20 Hz to 18 kHz 40 Hz to 15 kHz (According to DIN 45 500)	Distortion: Crosstalk:	Less than 1.0% (1 kHz 160 nWb/m)
	METAL-IV: 20 Hz to 19 kHz 40 Hz to 17 kHz (According to DIN 45 500)	Power Supply:	60 dB (at 1 kHz) or more AC 120V, 60 Hz (U, C) AC 100-110V, 115-127V 200-220V, 230-250V, 50/60 Hz (W) AC 220V, 50 Hz (FS) AC 240V, 50 Hz (BS, AU)
S/N (Signal to Noise Ratio):	Dolby B NR ON: 68 dB* Dolby C NR ON: 74 dB* Dolby NR OFF: 60 dB* * (A weighted, Reference 3% T.H.D. According to DIN 45 500)	Power Consumption: Dimensions: Weight:	22W 435 (W) x 110 (H) x 272 (D) mm 4.7 kg

SPECIFICATIONS AND PARTS ARE SUBJECT TO CHANGE FOR IMPROVEMENT.

## STEREO CASSETTE TAPE DECK

## SICHERHEITSMASSNAHMEN

Bei Wartungsarbeiten sind die folgenden Sicherheitsmaßnahmen zu beachten.

- Da verschiedene Teile dieses Gerätes Sicherheitsfunktionen aufweisen, nur Original-Hitachi-Ersatzteile verwenden. Kritische Teile im Netzteil sollten nicht durch ähnliche Teile anderer Hersteller ersetzt werden. Alle kritischen Teile sind im Schaltplan mit dem Symbol  $\Delta$  gekennzeichnet.
- Vor der Auslieferung eines reparierten Gerätes an den Kunden muß der Wartungstechniker das Gerät einer gründlichen Prüfung unterziehen, um sicherzustellen, daß sicherer Betrieb ohne die Gefahr von elektrischen Schlägen gewährleistet ist.

## TECHNISCHE DATEN

Spursystem:	4-Spur, 2-Kanal-Stereo	Gleichlaufschwankungen:	0,04% (WRMS) 0,13% (nach DIN 45 500)
Tonband:	Cassetten-Tonband	Eingangsempfindlichkeit und Impedanz:	Mikrofon: 0,54 mV (geeignete Mikrofonimpedanz 300 Ohm bis 5 kOhm) LINE IN: 97 mV, 50 kOhm oder mehr 500 mV
Bandlaufgeschwindigkeit:	4,75 cm/s	Ausgangspegel:	500 mV
Aufnahmesystem und Vormagnetisierungs-frequenz:	HF-Vormagnetisierung, 85 kHz	Ausgangsiastimpedanz:	LINE OUT: 50 kOhm oder mehr Kopfhörer: 8 Ohm bis 2 kOhm (geeignet)
Löschsystem:	HF-Löschung	Klirrgrad:	Weniger als 1,0% (1 kHz, 160 nWb/m)
Löschdämpfung:	65 dB (bei 1 kHz) oder mehr	Übersprechdämpfung:	60 dB (bei 1 kHz) oder mehr
Frequenzgang:	NOR-I: 20 Hz bis 16 kHz 40 Hz bis 14 kHz (nach DIN 45 500) CrO <sub>2</sub> -II: 20 Hz bis 18 kHz 40 Hz bis 15 kHz (nach DIN 45 500) METAL-IV: 20 Hz bis 19 kHz 40 Hz bis 17 kHz (nach DIN 45 500)	Spannungsversorgung:	AC 120V, 60Hz (U, C) 100-110V, 115-127V 200-220V, 230-250V, 50/60 Hz (W) AC 220V, 50 Hz (FS) AC 240V, 50 Hz (BS, AU)
Fremdspannungsabstand:	Mit Dolby-B-NR: 68 dB* Mit Dolby-C-NR: 74 dB* Ohne Dolby-NR: 60 dB* * (Bewertungsfilter A, 3% Klirr, Reineisenband nach DIN 45 500)	Leistungsaufnahme:	22W
		Abmessungen:	435 (B) x 110 (H) x 272 (T) mm
		Gewicht:	4,7 kg

Technische Änderungen vorbehalten.

## PRÉCAUTIONS DE SÉCURITÉ

Les précautions suivantes doivent être observées chaque fois qu'une réparation doit être faite.

- Étant donné que de nombreux composants de l'appareil possèdent des caractéristiques relatives à la sécurité, utiliser uniquement des pièces de rechange d'origine Hitachi pour effectuer un remplacement. Ceci se rapporte notamment aux pièces critiques du bloc d'alimentation qui ne doivent en aucun cas être remplacées par celles d'autres fabricants. Les pièces critiques sont accompagnées du symbole  $\Delta$  dans le schéma de montage.
- Avant de retourner l'appareil réparé au client, le technicien doit procéder à un essai complet pour s'assurer qu'il ne présente aucun danger de chocs électriques.

## FICHE TECHNIQUES

Système piste:	4 pistes, 2 canaux stéréo	CrO <sub>2</sub> -II:	(d'après DIN 45 500) De 20 Hz à 18 kHz De 40 Hz à 15 kHz (d'après DIN 45 500)
Bande:	Bande en cassette	METAL-IV:	De 20 Hz à 19 kHz De 40 Hz à 17 kHz (d'après DIN 45 500)
Vitesse de défilement:	4,75 cm/seconde	Rapport signal/bruit:	Avec Dolby NR B: 68 dB* Avec Dolby NR C: 74 dB*
Système d'enregistrement et fréquence de polarisation:	Polarisation C.A., 85 kHz		
Système d'effacement:	Effacement C.A.		
Rapport d'effacement:	65 dB (à 1 kHz) ou plus		
Réponse en fréquence:	NOR-I: De 20 Hz à 16 kHz De 40 Hz à 14 kHz		

Sans Dolby NR: 60 dB\*  
\* (Pondéré A, référence 3% D.H.T.)  
(d'après DIN 45 500)

Pleurage et scintillement:

0,04% (WRMS)  
0,13% (d'après DIN 45 500)

Sensibilité d'entrée et impédance:

Microphone: 0,54 mV  
(Impédance de microphone correcte de 300 ohms à 5 kohms)  
Entrée de ligne: 97 mV,  
50 kohms ou plus  
500 mV

Niveau de sortie: Impédance de charge de sortie:

Sortie de ligne: 50 kohms ou plus  
Casque d'écoute: De 8 ohms à 2

Distorsion:

kohms (appropriée)  
Moins de 1,0% (à 1 kHz, 160 nWb/m)

Diaphonie: Alimentation:

60 dB (à 1 kHz) ou plus  
CA 120V, 60 Hz (U, C)  
CA 100-110V, 115-127V  
200-220V, 230-250V,  
50/60 Hz (W)  
CA 220V, 50 Hz (FS)  
CA 240V, 50 Hz (BS, AU)

Consommation électrique:

22W

Dimensions:

435 (L) x 110 (H) x 272 (P) mm

Poids:

4,7 kg

Ces caractéristiques peuvent être modifiées sans préavis pour amélioration des performances.

## FEATURES

- Record/Playback auto reverse**  
Quick reversing of tape running by sensing the end of a magnetic tape and the beginning of a leader tape by means of the LED tape sensor. Continuous recording and playback are possible scarcely allowing the listener to feel the intermission of sound at reversing.
- Built-in Dolby C-Type**
- Light operation thanks to thin feather touches and the computer IC logic.**
- The computer AUTO REC MUTE function which allows a non-recorded section lasting about 4 seconds to be automatically prepared at one touch.**
- Jump selection function (DRPS), scanplay function (S & P), tape standby function, multi-repeat function, music heading (SPSS), and tape counter auto reset function.**

## MERKMALE

- Aufnahme/Wiedergabe-Autoreverse**  
Schnelle Laufumkehr durch Feststellen des Magnetbandendes und Vorspannbandanfanges mittels LED-Bandsensor. Kontinuierliche Aufnahme und Wiedergabe, wobei die durch die Laufumkehr verursachte Unterbrechung kaum wahrnehmbar ist.
- Eingebaute Dolby-C-Rauschunterdrückung**
- Leichtgängige Kurzhubtasten und IC-Logikschaltung**
- Aufnahme-Mutingfunktion für automatisches Anfertigen von Leerstellen mit einer Spieldauer von vier Sekunden**
- Titelwahl (DRPS), Scanplay (S & P), Abspielbereitschaft, Multi-Repeat, Titelspeicherung (SPSS) und automatische Bandzählwerkrückstellung.**

## CARACTÉRISTIQUES

- Inversion automatique en mode d'enregistrement/lecture**  
Inversion rapide du défilement par détection de l'amorce du ruban magnétique à ses deux extrémités à l'aide d'un senseur de bande à diode électroluminescente. Un enregistrement ou une lecture en continu sont ainsi possibles sans que l'auditeur s'aperçoive pratiquement de la brève intermission du son lors de l'inversion du défilement.
- Incorporation d'un Dolby de type C**
- Fonctionnement en douceur grâce à des touches à effleurement et des circuits intégrés logiques.**
- Fonction automatisée de la sourdine à l'enregistrement, permettant la création d'espaces vierges de 4 secondes environ entre les plages successives d'une cassette par simple poussée sur une touche.**
- Fonction de sélection par "saut" (DRPS), fonction de recherche et lecture (S & P), fonction de mise en attente, fonction de répétition multiple, fonction d'en-tête musicale (SPSS) et fonction d'annulation automatique du compteur de bande.**

## MAJOR FUNCTIONS AND HANDLING METHOD

### 1. Quick reverse function

The running direction of tape is automatically switched over by sensing the joint between the magnetic and leader tapes by means of the LED sensor while the tape is running.

The MODE SELECTOR allows selection from among: one-way (recording/playback only in the forward or reverse direction); two-way (when recording/playback in the forward direction is over, the tape run automatically changes to the reverse direction and recording/playback starts); and endless (continuous playback from the forward direction to the reverse direction and vice versa until the STOP button is pressed).

### 2. Tape standby function

When the FAST FORWARD and REWIND buttons are pressed at the same time, the tape is rewound up to its beginning, then the first portion of the leader tape is fast forwarded to create a tape standby state.

### 3. Tape counter auto reset function

When the REWIND button is pressed, the tape is rewound up to its beginning, at which time the counter display is automatically set to 000.

### 4. Scanaplay function

When the S & P (scanaplay) button is pressed, the tape counter assumes a music selection mode. Scanaplay begins after the tape is rewound up to its beginning. Perform the first part of each piece of music only for 10 seconds, and press the MEMORY button during this interval to make the unit memorize it. Up to 15 pieces of music can be memorized. When rewinding is done, the tape is rewound up to the music which was memorized at first, and playback is performed once.

### 5. Multi-repeat function

Repeated tape playback is possible from the point where the PLAYBACK button was pressed at last to the point where the MULTI-REPEAT button was pressed during playback. Thus the tape can be played back for the number of times which was indicated to the selection counter (15 times at maximum).

### 6. SPSS

Heading of the piece of music you are now listening is possible by pressing the REWIND button while pressing the PLAYBACK button. Also heading of the next piece of music is possible by pressing the FAST FORWARD button while pressing the PLAYBACK button.

### 7. DRPS (jump selection)

The desired number of pieces of music is displayed on the selection counter using PROGRAM button by counting the number of pieces of music which lie before or after the desired music. Then the desired piece of music can be automatically played back by pressing the REWIND button or the FAST FORWARD button.

### 8. Auto tape selector

When a tape is mounted, its type is automatically identified through the detection hole, and bias and the equalizer are set.

## HAUPTFUNKTIONEN UND HANDHABUNG

### 1. Schnelle Laufumkehr

Die Richtung des Bandlaufes wird automatisch durch Feststellen des Überganges vom Magnetband zum Vorspannband mittels Infrarotsensor während des Bandlaufes umgekehrt.

Der BETRIEBSARTENWÄHLER erlaubt folgende Wahlmöglichkeiten: eine Richtung (Aufnahme/Wiedergabe nur bei Vor- oder Rücklauf); zwei Richtungen (wenn die Aufnahme/Wiedergabe bei Vorlauf beendet ist, schaltet das Band automatisch auf Rücklauf um und die Aufnahme/Wiedergabe beginnt); sowie endlos (kontinuierliche Wiedergabe vom Vorlauf bis Rücklauf und umgekehrt, bis die STOP-TASTE betätigt wird).

### 2. Abspielbereitschaft

Wenn die TASTEN für SCHNELLEN VORLAUF und RÜCKLAUF gleichzeitig gedrückt werden, wird das Band zum Bandanfang gespult, dann der erste Teil des Vorspannbandes im schnellen Vorlauf bis zum Beginn des Magnetbandes gespult, so daß Abspielbereitschaft besteht.

### 3. Automatische Bandzählwerkrückstellung

Bei Betätigung der RÜCKSPULTASTE wird das Band bis zu seinem Anfang gespult, wobei dann das Bandzählwerk automatisch auf "000" gestellt wird.

### 4. Scanaplay

Wenn die S & P-Taste (Scanaplay) betätigt wird, stellt sich das Bandzählwerk auf Musikwahlbetrieb ein. Scanaplay beginnt, nachdem das Band bis zu seinem Anfang gespult worden ist. Den ersten Teil einer Musikaufnahme für 10 Sekunden abspielen und die SPEICHERTASTE (MEMORY) während des Abspielens betätigen, damit dieser Aufnahmeteil gespeichert wird. Bis zu 15 Musikstücke können auf diese Weise gespeichert werden. Wenn der Rücklauf beendet ist, wird das Band bis zu dem Musikstück, das als erstes gespeichert wurde, gespult und das Musikstück wird einmal abgespielt.

### 5. Multi-Repeat-Funktion

Wiederholte Wiedergabe ist möglich ab der Stelle, wo die Wiedergabetaste zuletzt gedrückt wurde, bis zu der Stelle, wo die MULTI-REPEAT-TASTE (MULTI-REPEAT) während der Wiedergabe betätigt wurde. Das Band kann daher so oft abgespielt werden, wie auf dem Zähler (max. 15 Mal) eingestellt.

### 6. SPSS

Titelspeicherung des Musikstückes, das gerade abgehört wird, ist durch Betätigen der RÜCKLAUFTASTE, während die WIEDERGABETASTE gedrückt wird, möglich. Titelwahl des nächsten Musikstückes erfolgt durch Betätigen der SCHNELL-VORLAUFTASTE, während die WIEDERGABETASTE gedrückt wird.

### 7. DPRS (Titelwahl)

Die gewünschte Anzahl von Musikstücken wird in den Zähler mit den PROGRAMMTASTE durch Zählen der Musikstücke, die sich vor oder nach dem gewünschten Musikstück befinden, eingegeben. Das gewählte Musikstück kann dann automatisch durch Betätigen der RÜCKLAUFTASTE oder SCHNELL-VORLAUFTASTE abgespielt werden.

### 8. Automatischer Bandsortenwähler

Das eingelegte Band wird durch eine Identifikationsöffnung bezügliche Bandsorte identifiziert, worauf die entsprechende Einstellung der Vormagnetisierung und Entzerrung eingestellt wird.

## FONCTIONS PRINCIPALES ET MÉTHODE D'UTILISATION

### 1. Fonction d'inversion rapide

Pendant le défilement de la bande, sa direction est automatiquement inversée par détection du joint existant entre la bande magnétique proprement dite et son amorce, détection opérée par un senseur à rayon infrarouge. Le SÉLECTER DE MODE offre le choix suivant: une direction (enregistrement/lecture uniquement en marche avant ou en marche arrière); deux directions (quand l'enregistrement/lecture en marche avant est achevée, la bande commence automatiquement à défiler dans le sens opposé et l'enregistrement/lecture s'accomplit dans ce sens); ou fonctionnement sans limite (lecture continue de la marche avant vers la marche arrière et vice versa jusqu'à ce que la TOUCHE D'ARRÊT soit actionnée).

### 2. Fonction de mise en attente de la bande

Quand les TOUCHES D'AVANCE RAPIDE et de REBOBINAGE sont simultanément actionnées, la bande se rebobine jusqu'à son début; ensuite, la première portion de l'amorce est avancée rapidement de manière que la bande se trouve en mode d'attente.

### 3. Fonction d'annulation automatique du compteur de bande

Quand la TOUCHE DE REBOBINAGE est actionnée, la bande est rebobinée jusqu'à son début et, à ce moment, l'affichage du compteur de bande revient de lui-même à "000".

### 4. Fonction de recherche et lecture

Lorsque la touche S & P (recherche & lecture) est actionnée, le compteur de bande se place en mode de sélection musicale. La recherche/lecture commence après que la bande a été rebobinée jusqu'à son début. Procéder à la lecture des .10 premières secondes de chaque plage musicale et appuyer sur la TOUCHE DE MÉMORISATION (MEMORY) pendant cet intervalle de sorte que l'appareil mémorise ces divers passages. Un maximum de 15 plages musicales peuvent ainsi être mémorisées. Lorsque l'on actionne la touche de rebobinage, la bande se rebobine jusqu'à la musique qui a été mémorisée en premier lieu et la lecture s'accomplit.

### 5. Fonction de répétitions multiples

Une répétition de la lecture d'une bande est possible depuis le point où la TOUCHE DE LECTURE a été actionnée en dernier jusqu'au point où la TOUCHE DE RÉPÉTITION MULTIPLE (MULTI-REPEAT) a été actionnée pendant la lecture. Par conséquent la bande peut être lue autant de fois qu'il est indiqué sur le compteur de sélection (15 fois au maximum).

### 6. En-tête musicale (SPSS)

Un passage à l'en-tête de la plage en cours de lecture est possible par poussée sur la TOUCHE DE REBOBINAGE pendant que la TOUCHE DE LECTURE est actionnée. En outre, le passage à l'en-tête de la plage suivante s'accomplit par poussée sur la TOUCHE D'AVANCE RAPIDE pendant qu'est enfoncée la TOUCHE DE LECTURE.

### 7. Sélection par "saut" (DRPS)

Le numéro des plages musicales souhaitées est affiché sur le compteur de sélection à l'aide la TOUCHE DE PROGRAMME en comptant le nombre de plages précédant ou suivant la musique souhaitée. On peut alors reproduire automatiquement la plage musicale souhaitée en appuyant sur la TOUCHE DE REBOBINAGE ou sur celle D'AVANCE RAPIDE.

### 8. Sélecteur automatique de bande

Dès qu'une bande est installée dans l'appareil, son type est automatiquement identifié par les orifices de détection de sorte que la polarisation et la correction appropriées soient réglées.

## DISASSEMBLY

### 1. Cassette lid (Fig. 1)

After opening cassette door by pressing the EJECT button and remove 1 Nylon rivet, remove cassette lid by pulling it upward.

### 2. Front panel (Fig. 2)

Remove 2 screws ①, 2 screws ② and 3 screws ③ after removing the cover and the cassette lid. Then disengage the FL meter P.W. board and main P.W. board connectors (5 locations), and pull out the front panel forward.

### 3. FL meter P.W. board

Disengage 2 nails after removing 2 screws ④. (To be changed together with the P.W. board during service) (Fig. 3)

### 4. Control P.W. board

Disengage 5 nails after removing 4 screws ⑤. (Fig. 3)

### 5. Slide volume P.W. board

After removing front metal after removing 1 screw ⑥, remove 2 screws ⑦ and 2 nails. (Fig. 3)

### 6. Main P.W. board (Fig. 4)

Remove 5 screws ⑧ after removing front panel, and pull out the main P.W. board forward.

### 7. Control buttons (Fig. 5)

#### (1) Play button

Disengage play button by pushing the fixed section (A) in the direction of arrow after removing the control P.W. board.

#### (2) Pause and stop buttons

Disengage pause shaft by pushing 1 nail (B) in the direction of arrow after removing the control P.W. board. Then disengage buttons by pushing 2 nails (C) in the direction of arrow.

### 8. Cassette chassis (Fig. 6)

Remove 2 screws ⑨ and 1 screw ⑩ after removing the front panel.

### 9. Cassette chassis unit

#### (1) Cassette holder (Fig. 7)

Open cassette holder by pushing the cassette take-out lever. Then remove cassette holder by pushing it in the direction of arrow (A) after removing E-ring and cassette holder spring. When remounting cassette holder, previously insert air damper.

#### (2) Cassette metal (Fig. 8)

Remove 2 screws ⑪ after disengaging cassette holder.

#### (3) Flywheel support (Fig. 9)

Hook flywheel belt to nail (A). Then remove 3 screws ⑫, and disengage flywheel support together with the DC motor.

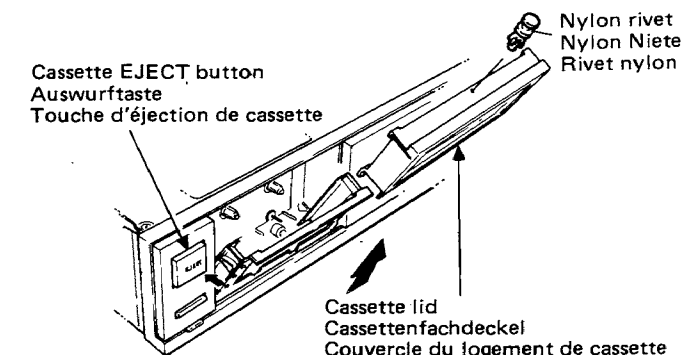


Fig. 1 Abb. 1

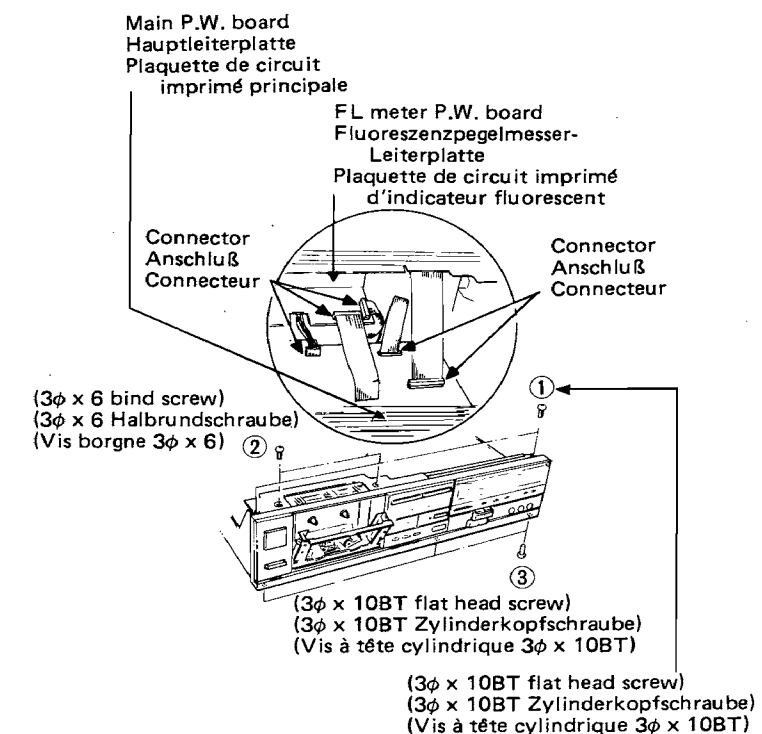


Fig. 2 Abb. 2

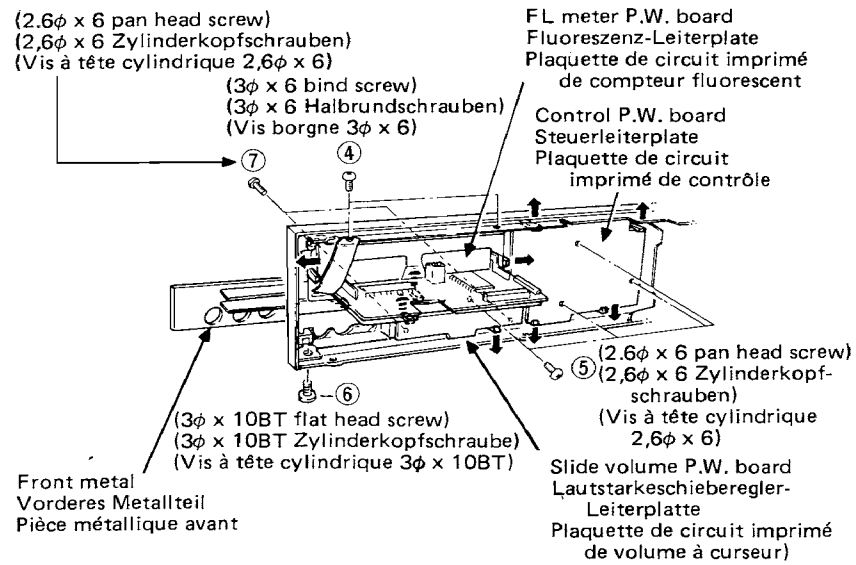


Fig. 3 Abb. 3

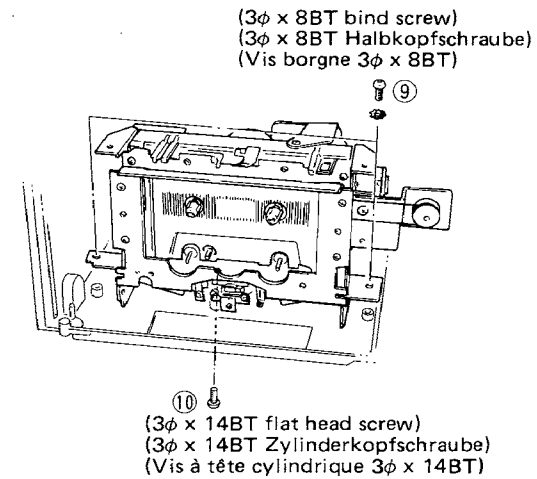


Fig. 6 Abb. 6

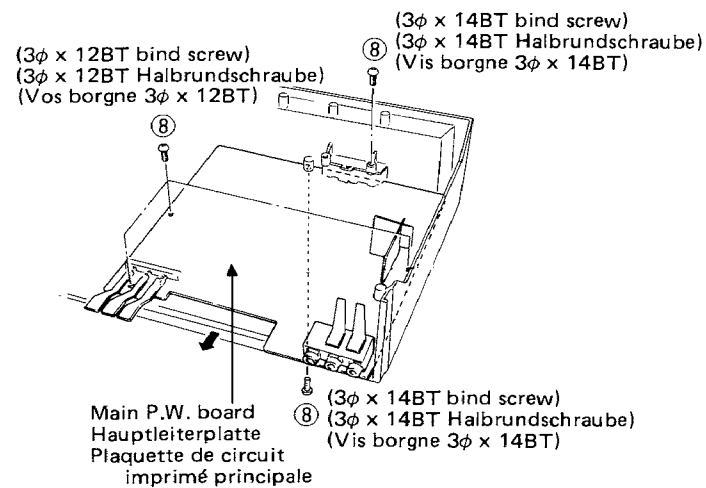


Fig. 4 Abb. 4

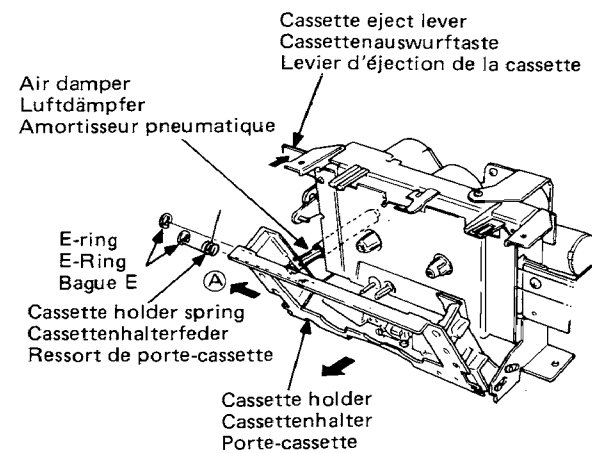


Fig. 7 Abb. 7

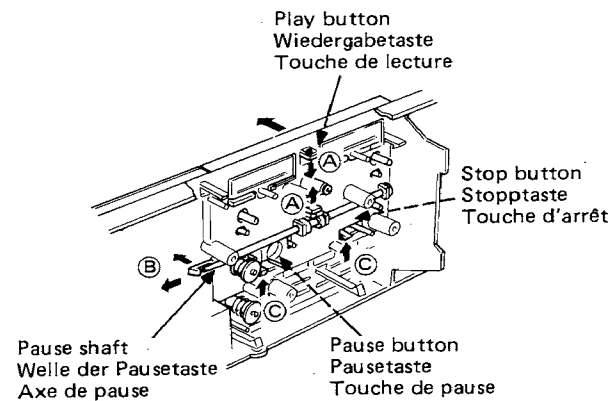


Fig. 5 Abb. 5

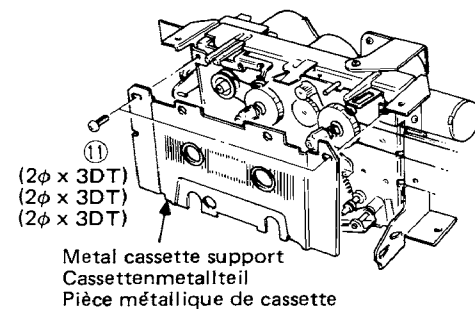


Fig. 8 Abb. 8

## DEMONTAGE

## 1. Cassettenfachdeckel (Abb. 1)

Den Cassettenfachdeckel durch Betätigen der Auswurf-taste öffnen, danach die Nylon-Niete entfernen und durch Ziehen nach oben abnehmen.

## 2. Fronttafel (Abb. 2)

Die 2 Schrauben ① und ② sowie 3 Schrauben ③ nach dem Abnehmen der oberen Abdeckung und des Cassettenfachdeckels entfernen. Dann die Anschlüsse (5 Stellen) der Fluoreszenzpegelmesser-Leiterplatte und der Hauptleiterplatte trennen und die Fronttafel nach vorn ziehen.

## 3. Fluoreszenzpegelmesser-Leiterplatte

Die zwei Stifte nach dem Entfernen der 2 Schrauben ④ lösen. (Zusammen mit der Leiterplatte bei der Wartung austauschen). (Abb. 3)

## 4. Steuerleiterplatte

Die fünf Stifte nach dem Entfernen der vier Schrauben ⑤ lösen. (Abb. 3)

## 5. Lautstärkeschieberegler-Leiterplatte

Das vordere Metallteil nach dem Lösen der Schraube ⑥ abnehmen und dann die zwei Schrauben ⑦ und beiden Stifte lösen. (Abb. 3)

## 6. Hauptleiterplatte (Abb. 4)

Die fünf Schrauben ⑧ nach dem Abnehmen der Fronttafel entfernen und die Hauptleiterplatte nach vorn herausziehen.

## 7. Bedientasten (Abb. 5)

## (1) Wiedergabetaste

Die Wiedergabetaste wird durch Drücken des fixierten Teils (A) in Pfeilrichtung nach Entfernen der Steuerleiterplatte, abgetrennt.

## (2) Pause- und Stop-Tasten

Die Welle der Pausetaste nach dem Entfernen der Steuerleiterplatte durch Drücken des Stiftes (B) in Pfeilrichtung trennen. Dann die Tasten durch Drücken der beiden Stifte (C) in Pfeilrichtung trennen.

## 8. Cassettenrecorderchassis (Abb. 6)

Die zwei Schrauben ⑨ und eine Schraube ⑩ nach dem Abnehmen der Frontplatte herausdrehen.

## 9. Cassettenrecorderchassiseinheit

## (1) Cassettenhalter (Abb. 7)

Cassettenhalter durch Betätigen der Auswurf-taste öffnen. Dann den E-Ring und die Cassettenhalterfeder entfernen und den Cassettenhalter durch Schieben in Pfeilrichtung (A) abnehmen. Beim Wiedereinbau des Cassettenhalters zuerst den Luftdämpfer einsetzen.

## (2) Cassetten-Metallstütze (Abb. 8)

Die zwei Schrauben ① nach dem Lösen des Cassettenhalters herausdrehen.

## (3) Schwungradstütze (Abb. 9)

Den Schwungradriemen in Stift (A) einhängen. Dann die drei Schrauben ② herausdrehen und die Schwungradstütze zusammen mit dem Gleichstrommotor abnehmen.

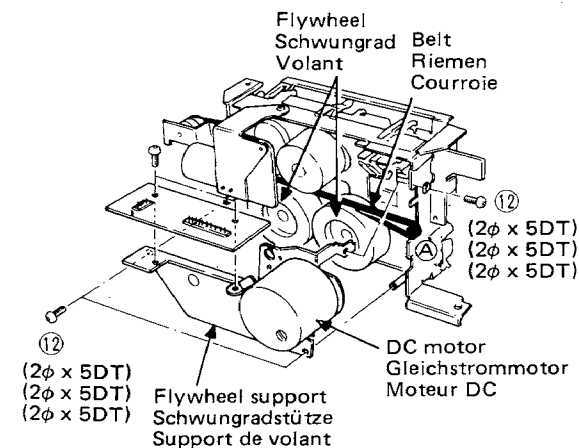


Fig. 9 Abb. 9

DÉMONTAGE

1. Couvercle du logement de la cassette (Fig. 1)

Après ouverture du couvercle par poussée sur la touche d'éjection de la cassette, retirer le rivet en nylon et le couvercle en le tirant vers le haut.

2. Panneau avant (Fig. 2)

Déposer les deux vis ①, les deux vis ② et les trois vis ③ après avoir enlevé le couvercle supérieur et le couvercle du logement de la cassette. Dégager ensuite les connecteurs de l'indicateur fluorescent, de la plaquette de circuit imprimé et la plaquette principale (5 endroits), puis retirer le panneau avant vers l'avant.

3. Plaquette de circuit imprimé de compteur fluorescent

Libérer les deux clous après avoir déposé les deux vis ④. (Pour changement avec la plaquette de circuit imprimé pendant l'entretien) (Fig. 3)

4. Plaquette de circuit imprimé de contrôle

Libérer les cinq clous après avoir déposé les quatre vis ⑤. (Fig. 3)

5. Plaquette de circuit imprimé pour volume à curseur

Après avoir déposé la pièce métallique frontale et une vis ⑥, déposer les deux vis ⑦ et les deux clous. (Fig. 3)

6. Plaquette de circuit imprimé principale (Fig. 4)

Déposer les cinq vis ⑧ après avoir déposé le panneau avant et retirer la plaquette de circuit imprimé principale vers l'avant.

7. Touches de commande (Fig. 5)

(1) Touche de lecture

Dégager la touche de lecture en poussant la section (A) fixe dans la direction de la flèche après avoir déposé la plaquette de circuit imprimé de contrôle.

(2) Touches de pause et d'arrêt

Dégager l'axe de pause en poussant un clou (B) dans le sens de la flèche après avoir déposé la plaquette de circuit imprimé de contrôle. Libérer ensuite les touches en poussant les deux clous (C) dans le sens de la flèche.

8. Châssis de cassette (Fig. 6)

Déposer les deux vis ⑨ et la vis ⑩ après avoir déposé le panneau avant.

9. Unité de châssis de cassette

(1) Porte-cassette (Fig. 7)

Ouvrir le porte-cassette par une poussée sur la touche d'éjection. Extraire ensuite le porte-cassette en le poussant dans la direction de la flèche (A) après avoir déposé la bague E et le ressort du porte-cassette. Lors du remontage du porte-cassette, insérer préalablement l'amortisseur pneumatique.

(2) Pièce métallique de cassette (Fig. 8)

Déposer les deux vis ⑪ après avoir libéré le porte-cassette.

(3) Support de volant (Fig. 9)

Accrocher la courroie de volant au clou (A). Déposer ensuite les trois vis ⑫ et libérer le support de volant en même temps que le moteur DC.

ADJUSTMENTS

• Adjustment points

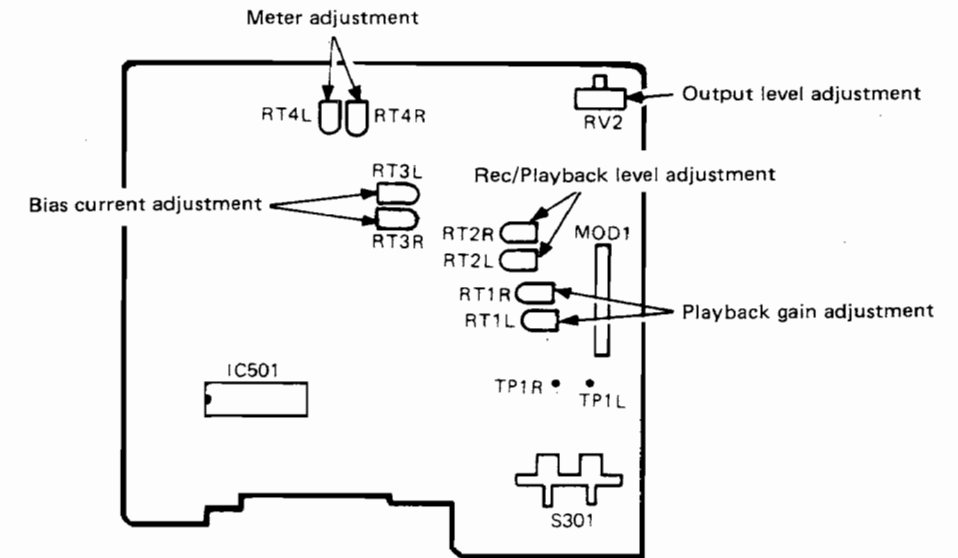


Fig. 10

• Measuring instruments

1. Audio oscillator
2. Electronic voltmeter
3. Attenuator
4. Frequency counter

• Jigs, and test and check tapes

1. Head mounting jig
2. 400 Hz, Dolby alignment tape
3. 10 kHz, azimuth alignment tape
4. 3,000 Hz, tape speed alignment tape
5. Mirror tape (tape run check)
6. NORMAL alignment tape (UD tape)
7. CHROME alignment tape (EX tape)
8. HITACHI METAL tape (C-46)

• Positions of knobs

Match the positions of switches and knobs to those shown in the table below unless otherwise specified.

Recording level control (RV1)	MAX
Output level control (RV2)	MAX
Dolby NR switch (S301)	OFF
Tape running direction	Forward

Remove the cassette lid and then clean the heads, pressure roller and capstan using alcohol; then perform adjustment according to the following procedure.

1. Tape Speed Adjustment

Input	Adjustment value	Adjustment point
Tape speed adjustment tape	3,000 +30 -10 Hz	Semi-fixed volume inside of the motor

Adjustment procedure

Connect the frequency counter to the LINE OUT terminals, apply heat-run for 20 minutes or more, and then playback the alignment tape and adjust the tape speed at the middle of the tape.

2. Azimuth Adjustment of Recording/Playback Head

Input	Adjustment value	Adjustment point
Azimuth correction tape	Maximum output	Azimuth adjustment screw

Adjustment procedure

Connect the electronic voltmeter to the LINE OUT terminals and playback the alignment tape to adjust the REC/PLAY head.

Adjust so that the output is maximum, but when the maximum values for L and R channels are different, adjust to the maximum value of L channel. Check that the difference between the values for the two channels is less than 2 dB at that time.

### 3. Playback Gain Adjustment and Level Meter Check

#### (1) Playback gain adjustment

Input	Adjustment value	Adjustment point
Dolby reference tape	490 mV $\pm$ 2 dB	RT1 L, R

#### Adjustment procedure

Connect the electronic voltmeter to the LINE OUT terminals, playback the Dolby reference tape and adjust so that the reading of the electronic voltmeter is set to the adjustment value.

#### (2) Level meter check

- 1) Connect the audio oscillator to the LINE IN terminals via an attenuator to set the deck to the record mode.
- 2) Input a 400 Hz signal and adjust the LINE OUT terminal output voltage to 490 mV  $-0.5$  dB using the attenuator.
- 3) At this time, adjust RT4L, R so that the 0 dB point of the meter turns from OFF to ON.

### 4. Dolby NR operation check

#### • Dolby B type

- (1) Record using metal tape (ME C46) at 5 kHz,  $-40$  dB with respect to the Dolby level. Continuously record with "Dolby OFF" and "Dolby B".
- (2) Play back with "Dolby OFF" and check that the output difference between "Dolby OFF" and "Dolby B" is approx. 10 dB.

#### • Dolby C type

- (1) Record using metal tape (ME C46) at 1 kHz,  $-40$  dB with respect to the Dolby level. Continuously record with "Dolby OFF" and "Dolby C".
- (2) Play back with "Dolby OFF" and check that the output difference between "Dolby OFF" and "Dolby C" is approx. 16 dB.

### 5. Bias Current Adjustment and REC/PLAY Output Level Adjustment

Set RT3L, R to the center positions and record at the recording levels shown in the table below to adjust for each tape and check the playback level.

Order	Tape	Recording level			Playback level		Adjustment procedure
		Frequency (Hz)	Level	Adjustment point	Level	Adjustment location	
1	Normal tape	1.2k/12k	0 dB $-23$ dB	ATT	within $+1$ dB	RT3L, R	(1)
2	Normal tape	400	$-3$ dB	ATT	within $\pm 0.5$ dB	RT2L, R	(2)
3	Normal tape	1.2k/12k	0 dB $-23$ dB	ATT	within $+1.0$ dB	Check	(1)
4	*Chrome tape	1.2k/12k	0 dB $-23$ dB	ATT	within $\pm 3$ dB	Check	(1)
5	* HITACHI METAL tape	1.2k/12k	0 dB $-23$ dB	ATT	within $\pm 3$ dB	Check	(1)

#### Adjustment procedure

#### (1) Bias current adjustment

- 1) Connect an audio oscillator to the LINE IN terminals via an attenuator, set the deck to the record mode, and adjust the output of the audio oscillator so that the reading of the meter is 0 dB. Then, adjust the attenuator to set it to 0 dB  $-23$  dB (Frequency: 1.2 kHz).
- 2) Record in this state and then set the frequency of the audio oscillator to 12 kHz, and then perform recording.
- 3) Play back the recorded section, read the output and

check that the output difference between the 2 frequencies is within  $\pm 1$  dB.

- 4) When the output difference is out of  $\pm 1$  dB range, adjust RT3L, R properly and repeat recording/playing back in the same way so that the output difference is within  $\pm 1$  dB.

\* Perform check only with CHROME, METAL tapes. When the output difference is out of the specification ( $\pm 3$  dB), perform adjustment using NORMAL tape again.

### (2) REC/PLAY output level adjustment

- 1) Connect an audio oscillator to the LINE IN terminals, input a 400 Hz signal, set the unit to the record mode and adjust the output of the audio oscillator so that the reading of the meter is  $-3$  dB before recording.

- 2) Playback the recorded section to check that the output is within 0 dB  $\pm 0.5$  dB.

- 3) When the output difference is out of the  $\pm 0.5$  dB range, adjust RT2L, R properly and repeat recording/playing back in the same way so that the output difference is within  $\pm 0.5$  dB.

### 6. Cassette Chassis Checking and Adjustment

Item No.	Inspection Item		Reference Value	Remarks
1	Pressure roller	Compression strength	330 $\pm$ 40g	To be measured with tension gauge. (Fig. 11)
2	Torque	Fast forward, rewind	70g $\cdot$ cm $\sim$	To be measured with torque measuring cassette.
		Playback	35 $\sim$ 55g $\cdot$ cm	
3	Back tension	Feeding side	2.5 $\sim$ 4.0g $\cdot$ cm	To be measured using torque measuring cassette in playback mode. (Fig. 12)
		Take-up side	2.5 $\sim$ 4.0g $\cdot$ cm	
4	Braking torque	Feeding side	50g $\cdot$ cm or more	To be measured using tension gauge in stop state. (Fig. 13)
		Take-up side		

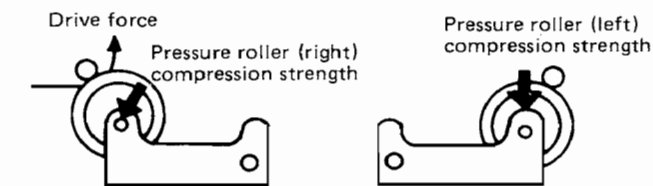


Fig. 11

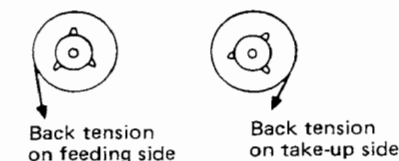


Fig. 12

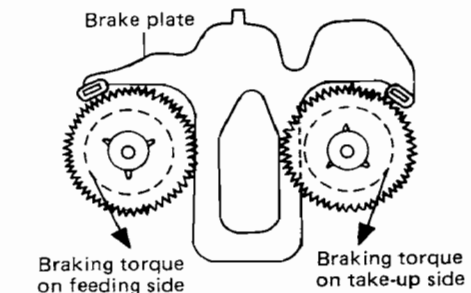
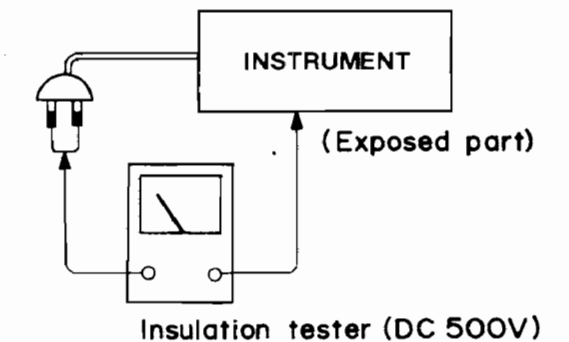


Fig. 13

Check that exposed parts are acceptably insulated from the supply circuit before returning the instrument repaired to the customer.

#### • Checking method

- Power switch is set to ON.  
Next, measure the resistance value between the both poles of attachment cup (Power supply plug) and the exposed parts (Parts such as Knob, Cover, etc. where the customer is easy to touch.) and check that the resistance value is 500 kohms or more.



EINSTELLUNGEN

• **Einstellpunkte**

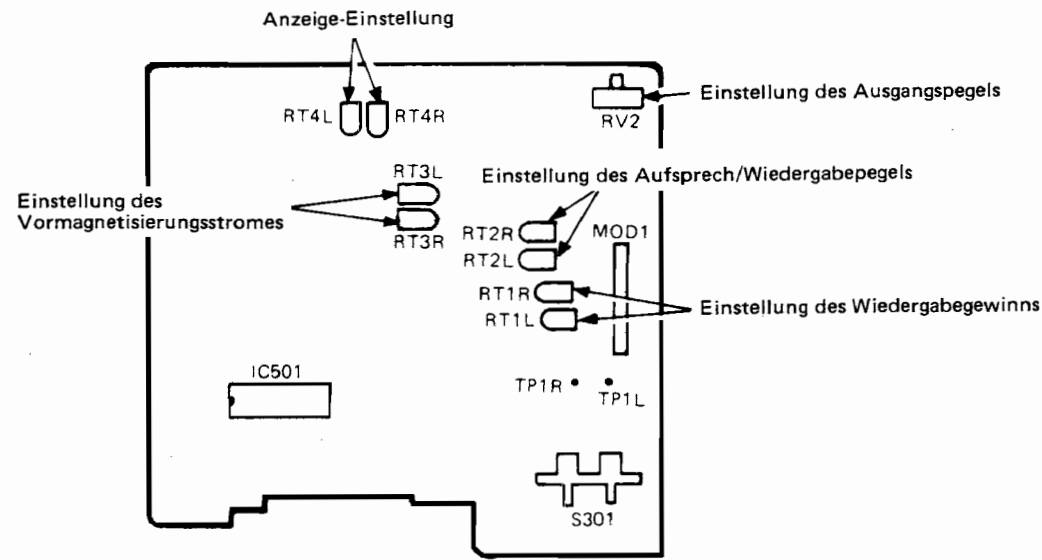


Abb. 10

• **Meßinstrumente**

1. Tonsignal-Oszillator
2. Elektronisches Voltmeter
3. Dämpfungsglied
4. Frequenzzähler

• **Vorrichtungen sowie Prüf- und Meßbänder**

1. Tonkopfeinbauvorrichtung
2. 400 Hz, Dolby-Abgleichband
3. 10 kHz, Azimut-Abgleichband
4. 3000 Hz, Bandgeschwindigkeits-Abgleichband
5. Spiegelmeßband (Bandlaufprüfung)
6. NORMAL-Abgleichband (UD-Band)
7. CHROME-Abgleichband (EX-Band)
8. Lo-D-METAL-Band (C-46)

• **Reglerposition**

Die Regler- und Tastenpositionen sind, falls nicht anders vorgeschrieben, wie unten angegeben, einzustellen.

Aufnahmepegelsteuerung (RV1)	MAX
Ausgangspegelsteuerung (RV2)	MAX
Dolby-NR-Schalter (S301)	OFF
Bandlaufrichtung	Vorlauf

Den Cassettenschachtdeckel abnehmen und die Tonköpfe, die Andruckrolle und Tonwelle mit einem in Alkohol angefeuchteten Wattestäbchen reinigen. Danach die Einstellungen wie folgt durchführen.

**1. Bandgeschwindigkeits-Einstellung**

Eingang	Einstellwert	Einstellpunkt
Bandgeschwindigkeit Abgleichband	3.000 +30 -10 Hz	Fester Pegel im Motor

**Einstellvorgang**

Den Frequenzzähler an die LINE OUT-Buchsen anschließen und das Gerät für mindestens 20 Minuten warmlaufen lassen; danach das Abgleichband abspielen und die Bandgeschwindigkeit in Bandmitte einstellen.

**2. Azimut-Einstellung des Aufsprech/Wiedergabekopfes**

Eingang	Einstellwert	Einstellpunkt
Azimut-Abgleichband	Maximaler Ausgang	Azimut-Einstellschraube

**Einstellvorgang**

Das elektronische Voltmeter an die LINE OUT-Buchsen anschließen und das Abgleichband abspielen, um den Aufsprech/Wiedergabekopf richtig einzustellen.

Die Einstellung auf max. Ausgangspegel vornehmen, wobei jedoch bei einer Differenz der Maximalwerte des linken und rechten Kanals auf den maximalen Pegel des linken Kanals einzustellen ist. Die Differenz zwischen den beiden Kanälen muß dabei weniger als 2 dB betragen.

**3. Einstellung des Wiedergabegewinns und der Pegelmesserkontrolle**

(1) **Einstellung des Wiedergabegewinns**

Eingang	Einstellwert	Einstellpunkt
Dolby Referenzband	490 mV ±2 dB	RT1 L,R

**Einstellvorgang**

Das elektronische Voltmeter an die LINE OUT-Buchsen anschließen, das Dolby-Referenzband abspielen und die Einstellung so vornehmen, daß das elektronische Voltmeter den Einstellwert anzeigt.

(2) **Pegelmesserkontrolle**

- 1) Den Tonsignal-Oszillator über ein Dämpfungsglied an die LINE IN-Buchsen anschließen, um den Cassettenrecorder auf Aufnahme einzustellen.
- 2) Ein 400 Hz Signal einspeisen und die Ausgangsspannung der LINE OUT-Buchsen mit dem Dämpfungsglied auf 490 mV -0,5 dB einstellen.
- 3) Dabei den RT4L und R so einstellen, daß sich die 0 dB Position der Anzeige von OFF (AUS) nach ON (EIN) verändert.

**5. Einstellung des Vormagnetisierungsstromes und des Aufnahme/Wiedergabe-Ausgangspegels**

RT3L, R in Mittelstellung bringen und Aufnahmen mit den in der nachfolgenden Tabelle aufgeführten Aufsprechpegeln durchführen (für jede Bandsorte) und den Wiedergabepegel kontrollieren.

Reihenfolge	Tonband	Aufnahmepegel			Wiedergabepegel		Einstellvorgang
		Frequenz (Hz)	Pegel	Einstellpunkt	Pegel	Einstellpunkt	
1	Normalband	1,2k/12k	0 dB -23 dB	ATT	Innerhalb +1 dB	RT3L, R	(1)
2	Normalband	400	-3 dB	ATT	Innerhalb ±0,5 dB	RT2L, R	(2)
3	Normalband	1,2k/2k	0 dB -23 dB	ATT	Innerhalb +1,0 dB	Prüfen	(1)
4	* Chromdioxidband	1,2k/12k	0 dB -23 dB	ATT	Innerhalb ±3 dB	Prüfen	(1)
5	* HITACHI Reineisenband	1,2k/12k	0 dB -23 dB	ATT	Innerhalb ±3 dB	Prüfen	(1)

**Einstellvorgang**

(1) **Einstellung des Vormagnetisierungsstromes**

- 1) Den Tonsignal-Oszillator über ein Dämpfungsglied an die LINE IN-Buchsen anschließen. Das Gerät auf Aufnahmefunktion schalten und den Ausgang des Tonsignal-Oszillators auf eine Anzeige von 0 dB der Pegelmesser einstellen. Dann das Dämpfungsglied auf einen Pegel von 0 dB -23 dB (Frequenz 1,2 kHz) einstellen.
- 2) In diesem Zustand ein 12 kHz Signal vom Tonsignal-Oszillator aufnehmen.
- 3) Das aufgenommene Signal wiedergeben und den

**4. Dolby-NR-Betriebskontrolle**

• **Dolby-B-Rauschunterdrückung**

- (1) Ein 5 kHz Signal mit einem Pegel von -40 dB gegenüber dem Dolby-Pegel auf Reineisenband (ME C46) aufzeichnen. Dieses Signal kontinuierlich bei auf "DOLBY OFF" und "DOLBY B" gestellten Wahlschalter aufnehmen.
- (2) Die Wiedergabe bei auf Position "DOLBY OFF" gestellten Wahlschalter vornehmen und darauf achten, daß der Unterschied zwischen "DOLBY OFF" und "DOLBY B" etwa 10 dB beträgt.

• **Dolby-C-Rauschunterdrückung**

- (1) Ein 1 kHz Signal mit einem Pegel von -40 dB gegenüber dem Dolby-Pegel auf Reineisenband (ME C46) aufzeichnen. Dieses Signal kontinuierlich bei auf Position "DOLBY OFF" und "DOLBY C" gestellten Wahlschalter aufnehmen.
- (2) Die Wiedergabe bei auf Position "DOLBY OFF" gestellten Wahlschalter vornehmen und darauf achten, daß der Unterschied zwischen "DOLBY OFF" und "DOLBY C" etwa 16 dB beträgt.

Pegel kontrollieren; die Differenz zwischen den beiden Frequenzen sollte weniger als ±1 dB betragen.

- 4) Wenn die Ausgangspegeldifferenz mehr als ±1 dB beträgt, RT3L, R abgleichen und die Aufnahme/Wiedergabe wiederholen, bis die Ausgangspegeldifferenz innerhalb von ±1 dB liegt.

\* Diese Prüfung nur mit Chrom- und Reineisenbändern durchführen. Falls die Ausgangspegeldifferenz außerhalb des zulässigen Bereichs (±3 dB) liegt, die Einstellung mit Normalband wiederholen.



**(2) Einstellung des Aufnahme/Wiedergabe-Ausgangspegels**

- 1) Einen Tonsignal-Oszillator an die LINE IN-Buchsen anschließen, ein 400 Hz Signal einspeisen, das Gerät auf Aufnahmefunktion schalten und den Tonsignal-Oszillator so einstellen, daß der Pegelmesser vor der Aufnahme -3 dB anzeigt.

- 2) Das aufgenommene Signal wiedergeben und darauf achten, daß der Ausgangspegel innerhalb von 0 dB  $\pm 0,5$  dB liegt.
- 3) Wenn die Ausgangspegeldifferenz mehr als  $\pm 0,5$  dB beträgt, RT2L, R abgleichen und die Aufnahme/Wiedergabe wiederholen, bis die Ausgangspegeldifferenz innerhalb von  $\pm 0,5$  dB liegt.

**6. Prüfung und Einstellung des Cassetten-Chassis**

Punkt	Prüfpunkt		Bezugswert	Bemerkungen
1	Andruckroll	Andrückkraft	330 $\pm$ 40g	Mit Zugkraftmeßgerät messen. (Abb. 11)
2	Drehmoment	Schnellvorlauf, Rücklauf	70g·cm~	Mit Drehmoment-Meßcassette messen.
		Wiedergabe	35~55g·cm	
3	Spannmoment	Vorratsteller	2,5~4,0g·cm	Mit Drehmoment-Meßcassette bei Wiedergabefunktion messen. (Abb. 12)
		Wickelteller	2,5~4,0g·cm	
4	Bremsmoment	Vorratsteller	50g·cm oder mehr	Mit Zugkraftmeßgerät bei Stoppfunktion messen. (Abb. 13)
		Wickelteller		

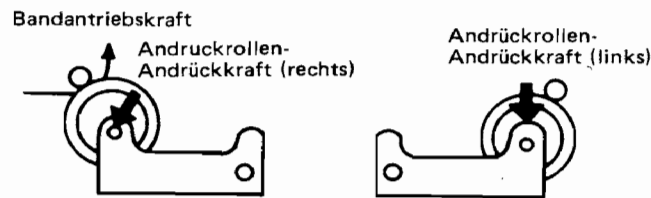


Abb. 11

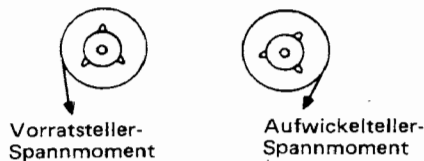


Abb. 12

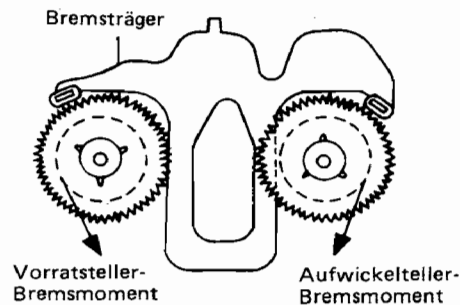


Abb. 13

MÉTHODES DE RÉGLAGE

● Points d'ajustement

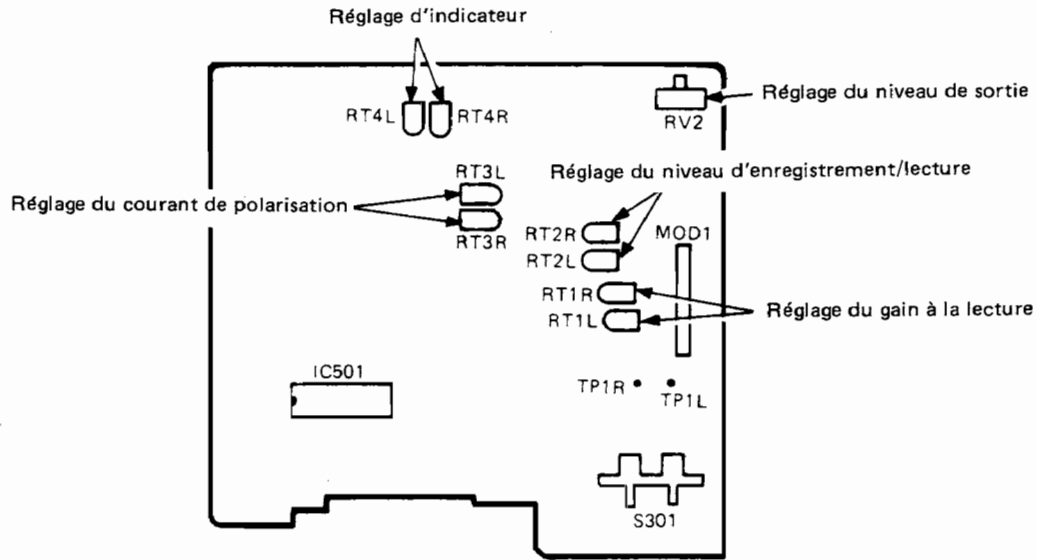


Fig. 10

● Instruments de mesure nécessaires

1. Oscillateur audio
2. Voltmètre électronique
3. Atténuateur
4. Fréquencemètre

● Calibres et bandes d'essai et de vérification

1. Calibre de montage de tête
2. Bande d'alignement Dolby, 400 Hz
3. Bande d'alignement d'azimuth, 10 kHz
4. Bande d'alignement de vitesse de bande, 3.000 Hz
5. Bande miroir (vérification de défilement de bande)
6. Bande d'alignement pour bande "Normal" (bande UD)
7. Bande d'alignement pour bande "Chrome" (bande EX)
8. Bande Lo-D METAL (C-46)

● Positions des boutons

A moins d'indication contraire, régler les commutateurs et boutons aux positions indiquées ci-dessous.

Commande de niveau d'enregistrement (RV1)	MAX
Commande de niveau de sortie (RV2)	MAX
Sélecteur de réducteur de bruit Dolby (S301)	OFF
Direction de défilement de bande	Marche avant

Retirer le couvercle du logement de la cassette, puis nettoyer les têtes, le galet presseur et le cabestan avec de l'alcool; procéder ensuite au réglage par la méthode suivante.

1. Réglage de la vitesse de bande

Entrée	Valeur de réglage	Point de réglage
Bande de réglage de vitesse de bande	3.000 $\pm$ 30 Hz	Volume semi-fixe à intérieur du moteur

Méthode de réglage

Raccorder le fréquencemètre aux bornes LINE OUT; procéder à un pré-chauffage pendant au moins 20 minutes et faire jouer ensuite la bande d'alignement pour ajuster la vitesse au milieu de la bande en question.

2. Réglage d'azimuth de la tête d'enregistrement/lecture

Entrée	Valeur de réglage	Point de réglage
Bande de correction d'azimuth	Sortie maximum	Vis de réglage d'azimuth

Méthode de réglage

Raccorder le voltmètre électronique aux bornes LINE OUT et faire jouer la bande d'alignement de manière à ajuster la tête d'enregistrement/lecture.

Ajuster de telle sorte que la sortie soit maximale; mais quand les valeurs maximales des canaux gauche et droit sont différentes, ajuster à la valeur maximale du canal gauche (L). Vérifier si la différence entre les valeurs des deux canaux est inférieure à 2 dB à ce stade.

### 3. Réglage du gain à la lecture et vérification de l'indicateur de niveau

#### (1) Réglage du gain à la lecture

Entrée	Valeur de réglage	Point de réglage
Bande de référence de Dolby	490 mV $\pm$ 2 dB	RT1 L,R

#### Méthode de réglage

Raccorder le voltmètre électronique aux bornes LINE OUT; procéder à la lecture de la bande d'alignement Dolby et ajuster de telle sorte que la lecture du voltmètre électronique soit à la valeur de réglage.

#### (2) Vérification de l'indicateur de niveau

- 1) Raccorder l'oscillateur audio aux bornes LINE IN, via un atténuateur et placer le magnétocassette en mode d'enregistrement.
- 2) Appliquer un signal de 400 Hz et ajuster la tension de sortie de la borne LINE OUT à 409 mV  $-0,5$  dB à l'aide de l'atténuateur.
- 3) A ce stade, ajuster RT4L, R de sorte que le point

### 5. Réglage de courant de polarisation et réglage du niveau de sortie d'enregistrement/lecture

Régler RT3L, R à leur position centrale et enregistrer au niveau d'enregistrement indiqué sur le tableau ci-dessous de manière à ajuster pour chaque bande et vérifier le niveau de lecture.

Ordre	Bande	Niveau d'enregistrement			Niveaux de lecture		Méthode de réglage
		Fréquence (Hz)	Niveau	Point de réglage	Niveau	Emplacement de réglage	
1	Bande normal	1,2k/12k	0 dB $-23$ dB	ATT	moins de $+1$ dB	RT3L, R	(1)
2	Bande normal	400	$-3$ dB	ATT	moins de $\pm 0,5$ dB	RT2L, R	(2)
3	Bande normal	1,2k/12k	0 dB $-23$ dB	ATT	moins de $+1,0$ dB	Vérification	(1)
4	*Bande chrome	1,2k/12k	0 dB $-23$ dB	ATT	moins de $\pm 3$ dB	Vérification	(1)
5	*Bande métal HITACHI	1,2k/12k	0 dB $-23$ dB	ATT	moins de $\pm 3$ dB	Vérification	(1)

#### Méthode de réglage

##### (1) Réglage du courant de polarisation

- 1) Raccorder un oscillateur audio aux bornes LINE IN via un atténuateur, régler le magnétophone en mode d'enregistrement et ajuster la sortie de l'oscilloscope audio de sorte que la lecture de l'indicateur soit 0 dB. Ajuster ensuite l'atténuateur pour le régler à 0 dB  $-23$  dB (Fréquence: 1,2 kHz).
- 2) Enregistrer dans cet état et régler ensuite la fréquence de l'oscillateur audio à 12 kHz, puis effectuer l'enregistrement.
- 3) Procéder à la lecture de la section enregistrée, lire la

0 dB de l'indicateur passe de OFF (éteint) à ON (allumé).

### 4. Vérification de fonctionnement du réducteur de bruit Dolby

#### • Dolby de type B

- (1) Enregistrer à l'aide d'une bande métal (ME C46) à 5 kHz,  $-40$  dB en rapport au niveau Dolby. Enregistrer de façon continue avec "Dolby OFF" et "Dolby B".
- (2) Procéder à la lecture avec "Dolby OFF" et vérifier si la différence de sortie entre "Dolby OFF" et "Dolby B" est d'environ 10 dB.

#### • Dolby de type C

- (1) Enregistrer à l'aide d'une bande métal (ME C46) à 1 kHz,  $-40$  dB en rapport avec le niveau Dolby. Enregistrer de façon continue avec "Dolby OFF" et "Dolby C".
- (2) Procéder à la lecture avec "Dolby OFF" et vérifier si la différence de sortie entre "Dolby OFF" et "Dolby C" est d'environ 16 dB.

### (2) Réglage de niveau de sortie d'enregistrement/lecture

- 1) Raccorder un oscillateur audio aux bornes LINE IN, entrer un signal de 400 Hz, régler l'appareil en mode d'enregistrement et ajuster la sortie de l'oscillateur audio de sorte que la lecture de l'indicateur arrive à  $-3$  dB avant l'enregistrement.

2) Procéder à la lecture de la section enregistrée et vérifier si la sortie arrive à 0 dB  $\pm 0,5$  dB près.

- 3) Si la différence de sortie ne respecte pas la plage de  $\pm 0,5$  dB, ajuster RT2L, R convenablement et répéter l'enregistrement/lecture de la même façon, de sorte que la différence de sortie soit à  $\pm 0,5$  dB près.

### 6. Vérification et réglage du châssis de cassette

N° d'élément	Élément à vérifier		Valeur de référence	Remarques
1	Galet de pression	Force de compression	330 $\pm$ 40g	A mesure à l'aide d'une jauge de tension. (Fig. 11)
2	Couple	Avance rapide, rebobinage	70g-cm~	A mesurer à l'aide d'une cassette de mesure de couple.
		Lecture	35~55g-cm	
3	Tension arrière	Côté récepteur	2,5~4,0g-cm	A mesurer à l'aide d'une cassette de mesure de couple en mode de lecture. (Fig. 12)
		Côté récepteur	2,5~4,0g-cm	
4	Couple de freinage	Côté débiteur	50g-cm ou davantage	A mesurer à l'aide d'une jauge de tension en mode d'arrêt. (Fig. 13)
		Côté récepteur		

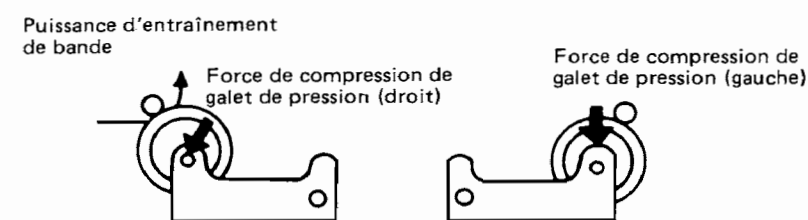


Fig. 11

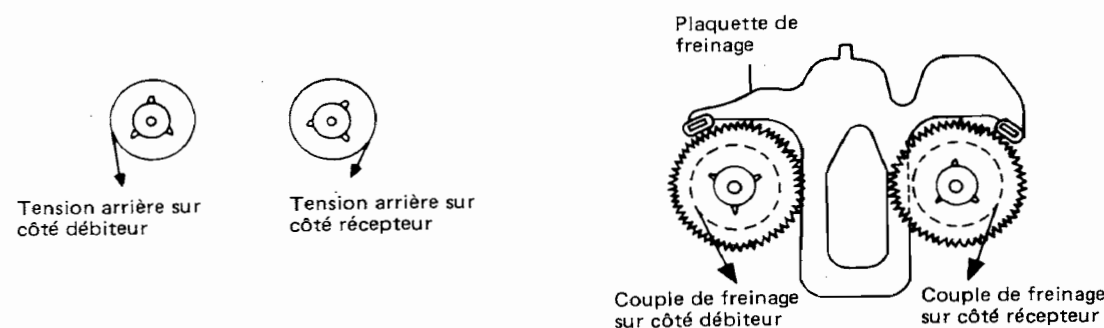


Fig. 12

Fig. 13

valeur de sortie et vérifier si la différence de sortie entre les deux fréquences est à  $\pm 1$  dB près.

- 4) Si la différence de sortie n'arrive pas dans la plage de  $\pm 1$  dB, ajuster RT3L, R convenablement et répéter l'enregistrement/lecture de la même façon de sorte que la différence de sortie arrive à  $\pm 1$  dB près.

\* Effectuer cette vérification uniquement avec des bandes CHROME et METAL. Lorsque la différence de sortie ne respecte pas la spécification ( $\pm 3$  dB), recommencer le réglage en se servant d'une bande NORMAL.

LUBRICATION

One or two drops of pan motor oil or sonic slider oil are applied to the rotary members. Hitasol or white grease is applied to the slidable members. Lubrication must be performed once a year given normal operation or once every 1000 hours. Be sure not to apply the oil to the belt and idlers.

Rotary member	between metal portions	pan motor oil (10W-40)
	between mold and metal	sonic slider oil (#1600)
Slidable members	between metals	Hitasol (MO-138)
	between molds and between mold and metal	white grease (FL-LUBE-A)

SCHMIERUNG

Auf allen Rotationsteilen sind ein oder zwei Tropfen Motoröl oder Schmieröl (Sonic Slider) aufzutragen, wogegen die Gleitteile mit Hitasol Schmierfett zu schmieren sind. Die Teile sollten einmal jährlich oder jeweils nach 1.000 Betriebsstunden geschmiert werden. Darauf achten, daß weder Öl noch Fett auf die Riemen und Zwischenscheiben gelangen.

Rotations- teil	Zwischen Metallteilen	Motoröl (10W-40)
	Zwischen Kunststoff und Metall	Schmieröl (Sonic Slider #1600)
Gleitteile	Zwischen Metallteilen	Hitasol (MO-138)
	Zwischen Kunststoffteilen sowie zwischen Kunststoff und Metall	Schmierfett (FL-LUBE-A)

LUBRIFICATION

Une ou deux gouttes d'huile moteur ou d'huile sonique sont appliquées sur les membres rotatifs. De la graisse Hitasol ou blanche est appliquée sur les membres coulissants. A raison d'une utilisation normale, un graissage s'impose une fois par an ou une fois toutes les 1.000 heures. Veiller à ne pas appliquer d'huile sur la courroie ou les galets.

Membre rotatif	entre les parties métalliques	huile moteur (10W-40)
	entre le moulage et le métal	huile sonique (#1600)
Membres coulissants	entre métaux	Hitasol (MO-138)
	entre moulures et et entre moulure et métal	graisse blanche (FL-LUBE-A)

DESCRIPTION OF NEW PARTS · BESCHREIBUNG DER NEUEN TEILE · DESCRIPTION DES NOUVELLES PIÈCES

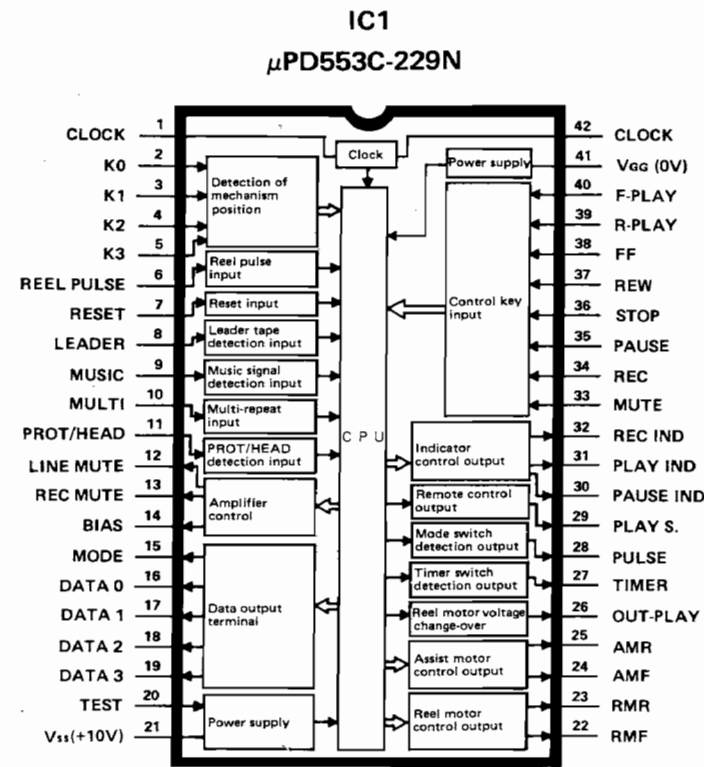


Fig. 14

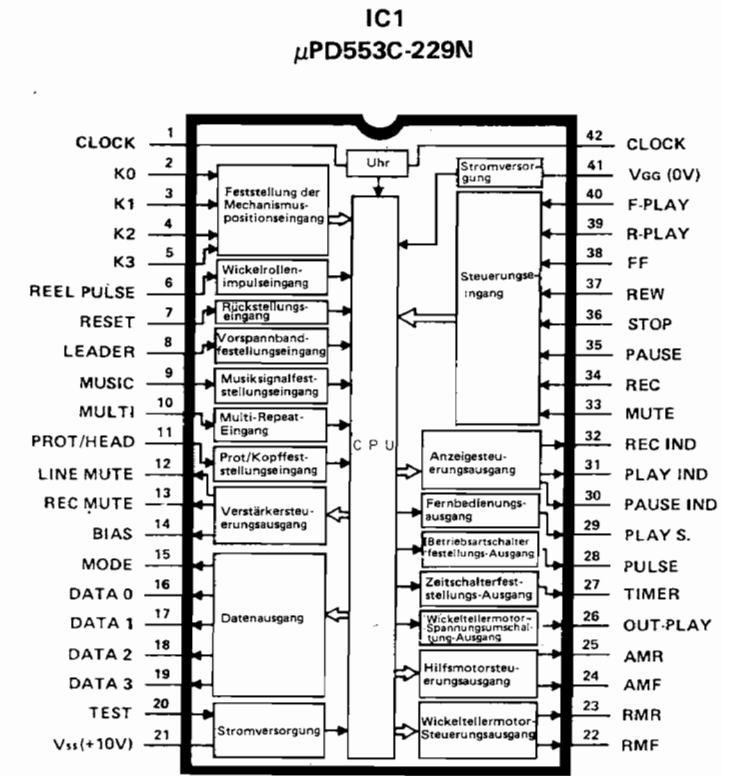


Abb. 14

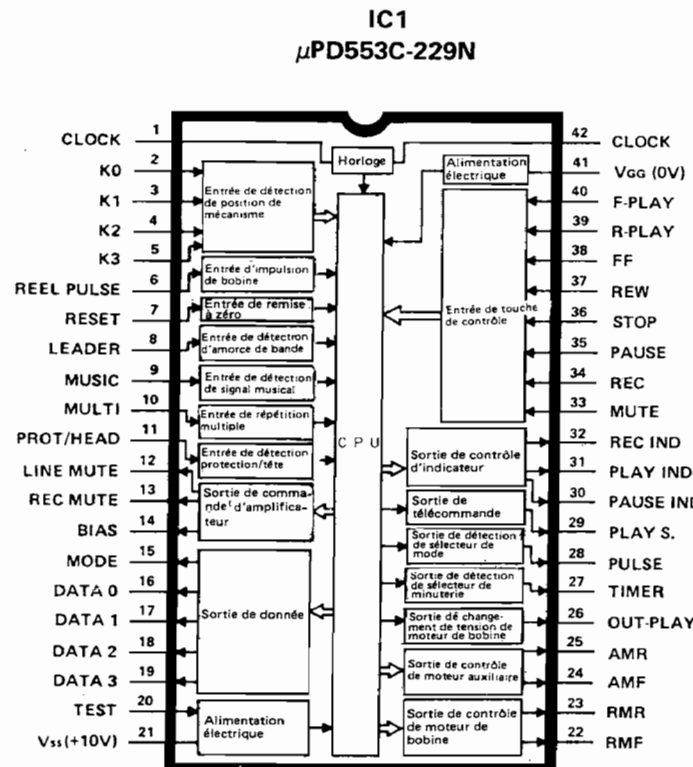


Fig. 14

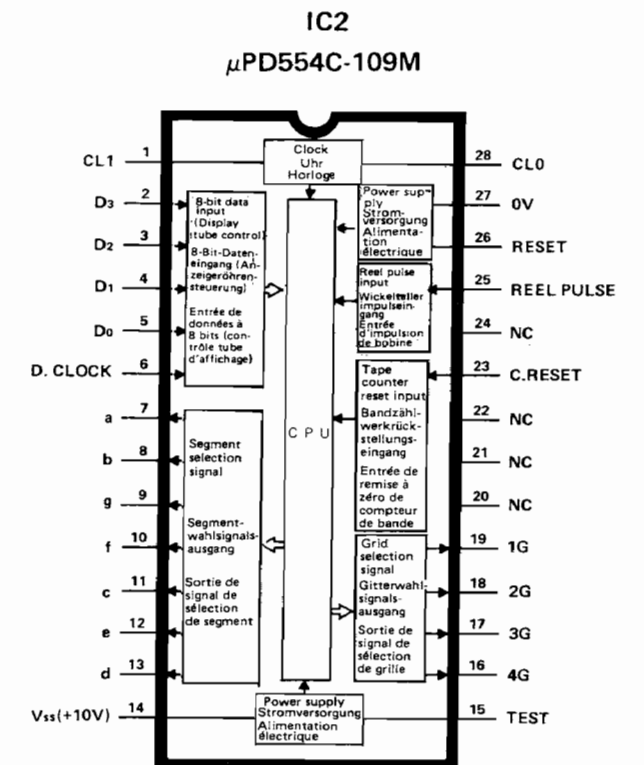


Fig. 15

Abb. 15

1.  $\mu$ PD554C-109M (counter microcomputer) terminal function table

Terminal No.	Terminal name	Function name	Functions																																																																																																																																																																																														
1	CL1	CL1	<ul style="list-style-type: none"> <li>Internal clock oscillation.</li> </ul>																																																																																																																																																																																														
2	PC0	D3	<ul style="list-style-type: none"> <li>Input of data for display tube control.</li> <li>Taking 8-bit data synchronized with the PD0 input clock into PC0 ~ PC3.</li> </ul> <p>Relationship between input data and display.</p> <table border="1"> <thead> <tr> <th colspan="4">At PD0 = "L" level</th> <th colspan="4">At PD0 = "H" level</th> <th rowspan="2">Display</th> </tr> <tr> <th>D3</th> <th>D2</th> <th>D1</th> <th>D0</th> <th>D3</th> <th>D2</th> <th>D1</th> <th>D0</th> </tr> </thead> <tbody> <tr> <td>0</td> <td>0</td> <td>0</td> <td>*1</td> <td>0</td> <td>(~ F)</td> <td></td> <td></td> <td>-00 (~ 15)</td> </tr> <tr> <td>0</td> <td>0</td> <td>1</td> <td>*1</td> <td>0</td> <td>(~ F)</td> <td></td> <td></td> <td>00 (~ 15)</td> </tr> <tr> <td>0</td> <td>1</td> <td>0</td> <td>*1</td> <td>0</td> <td>(~ F)</td> <td></td> <td></td> <td>R-00 (~ 15)</td> </tr> <tr> <td></td> <td></td> <td></td> <td></td> <td>0</td> <td>0</td> <td>1</td> <td>0</td> <td>End</td> </tr> <tr> <td></td> <td></td> <td></td> <td></td> <td>1</td> <td>0</td> <td>0</td> <td>0</td> <td>R</td> </tr> <tr> <td></td> <td></td> <td></td> <td></td> <td>1</td> <td>0</td> <td>1</td> <td>0</td> <td>R End</td> </tr> <tr> <td></td> <td></td> <td></td> <td></td> <td>1</td> <td>1</td> <td>0</td> <td>0</td> <td>R-</td> </tr> <tr> <td></td> <td></td> <td></td> <td></td> <td>1</td> <td>0</td> <td>0</td> <td>*1</td> <td>R-00 (~ 15)</td> </tr> <tr> <td></td> <td></td> <td></td> <td></td> <td>1</td> <td>0</td> <td>1</td> <td>*1</td> <td>Counter</td> </tr> <tr> <td></td> <td></td> <td></td> <td></td> <td>1</td> <td>1</td> <td>0</td> <td>*1</td> <td>R-00 (~ 15)</td> </tr> <tr> <td></td> <td></td> <td></td> <td></td> <td>1</td> <td>1</td> <td>1</td> <td>0</td> <td>No change (Only tape counter is cleared.)</td> </tr> </tbody> </table> <p>*1: "1" indicates counting up and "0" counting down, respectively, in the tape counter control data. *2: Anything.</p>	At PD0 = "L" level				At PD0 = "H" level				Display	D3	D2	D1	D0	D3	D2	D1	D0	0	0	0	*1	0	(~ F)			-00 (~ 15)	0	0	1	*1	0	(~ F)			00 (~ 15)	0	1	0	*1	0	(~ F)			R-00 (~ 15)					0	0	1	0	End					1	0	0	0	R					1	0	1	0	R End					1	1	0	0	R-					1	0	0	*1	R-00 (~ 15)					1	0	1	*1	Counter					1	1	0	*1	R-00 (~ 15)					1	1	1	0	No change (Only tape counter is cleared.)																																																																										
At PD0 = "L" level				At PD0 = "H" level				Display																																																																																																																																																																																									
D3	D2	D1		D0	D3	D2	D1		D0																																																																																																																																																																																								
0	0	0		*1	0	(~ F)			-00 (~ 15)																																																																																																																																																																																								
0	0	1		*1	0	(~ F)			00 (~ 15)																																																																																																																																																																																								
0	1	0		*1	0	(~ F)			R-00 (~ 15)																																																																																																																																																																																								
					0	0	1	0	End																																																																																																																																																																																								
				1	0	0	0	R																																																																																																																																																																																									
				1	0	1	0	R End																																																																																																																																																																																									
				1	1	0	0	R-																																																																																																																																																																																									
				1	0	0	*1	R-00 (~ 15)																																																																																																																																																																																									
				1	0	1	*1	Counter																																																																																																																																																																																									
				1	1	0	*1	R-00 (~ 15)																																																																																																																																																																																									
				1	1	1	0	No change (Only tape counter is cleared.)																																																																																																																																																																																									
7	PD1	a	<ul style="list-style-type: none"> <li>Segment control data output.</li> </ul> <p>Relationship between output data and display.</p> <table border="1"> <thead> <tr> <th rowspan="2">Display</th> <th colspan="7">Segment</th> <th rowspan="2">Display</th> <th colspan="7">Segment</th> </tr> <tr> <th>a</th> <th>b</th> <th>c</th> <th>d</th> <th>e</th> <th>f</th> <th>g</th> <th>a</th> <th>b</th> <th>c</th> <th>d</th> <th>e</th> <th>f</th> <th>g</th> </tr> </thead> <tbody> <tr> <td>1</td> <td>0</td> <td>1</td> <td>1</td> <td>0</td> <td>0</td> <td>0</td> <td>0</td> <td>R</td> <td>1</td> <td>1</td> <td>0</td> <td>1</td> <td>1</td> <td>1</td> <td>1</td> </tr> <tr> <td>2</td> <td>1</td> <td>1</td> <td>0</td> <td>1</td> <td>1</td> <td>0</td> <td>1</td> <td>E</td> <td>1</td> <td>0</td> <td>0</td> <td>1</td> <td>1</td> <td>1</td> <td>1</td> </tr> <tr> <td>3</td> <td>1</td> <td>1</td> <td>1</td> <td>1</td> <td>0</td> <td>0</td> <td>1</td> <td>n</td> <td>0</td> <td>0</td> <td>1</td> <td>0</td> <td>1</td> <td>0</td> <td>1</td> </tr> <tr> <td>4</td> <td>0</td> <td>1</td> <td>1</td> <td>0</td> <td>0</td> <td>1</td> <td>1</td> <td>d</td> <td>0</td> <td>1</td> <td>1</td> <td>1</td> <td>1</td> <td>0</td> <td>1</td> </tr> <tr> <td>5</td> <td>1</td> <td>0</td> <td>1</td> <td>1</td> <td>0</td> <td>1</td> <td>1</td> <td>-</td> <td>0</td> <td>0</td> <td>0</td> <td>0</td> <td>0</td> <td>0</td> <td>1</td> </tr> <tr> <td>6</td> <td>1</td> <td>0</td> <td>1</td> <td>1</td> <td>1</td> <td>1</td> <td>1</td> <td>r</td> <td>0</td> <td>0</td> <td>0</td> <td>0</td> <td>1</td> <td>1</td> <td>1</td> </tr> <tr> <td>7</td> <td>1</td> <td>1</td> <td>1</td> <td>0</td> <td>0</td> <td>1</td> <td>0</td> <td>R</td> <td>1</td> <td>1</td> <td>1</td> <td>0</td> <td>1</td> <td>1</td> <td>1</td> </tr> <tr> <td>8</td> <td>1</td> <td>1</td> <td>1</td> <td>1</td> <td>1</td> <td>1</td> <td>1</td> <td>E</td> <td>1</td> <td>0</td> <td>0</td> <td>1</td> <td>1</td> <td>1</td> <td>0</td> </tr> <tr> <td>9</td> <td>1</td> <td>1</td> <td>1</td> <td>1</td> <td>0</td> <td>1</td> <td>1</td> <td>P</td> <td>1</td> <td>1</td> <td>0</td> <td>0</td> <td>1</td> <td>1</td> <td>1</td> </tr> <tr> <td>0</td> <td>1</td> <td>1</td> <td>1</td> <td>1</td> <td>1</td> <td>1</td> <td>0</td> <td></td> <td></td> <td></td> <td></td> <td></td> <td></td> <td></td> <td></td> </tr> </tbody> </table>	Display	Segment							Display	Segment							a	b	c	d	e	f	g	a	b	c	d	e	f	g	1	0	1	1	0	0	0	0	R	1	1	0	1	1	1	1	2	1	1	0	1	1	0	1	E	1	0	0	1	1	1	1	3	1	1	1	1	0	0	1	n	0	0	1	0	1	0	1	4	0	1	1	0	0	1	1	d	0	1	1	1	1	0	1	5	1	0	1	1	0	1	1	-	0	0	0	0	0	0	1	6	1	0	1	1	1	1	1	r	0	0	0	0	1	1	1	7	1	1	1	0	0	1	0	R	1	1	1	0	1	1	1	8	1	1	1	1	1	1	1	E	1	0	0	1	1	1	0	9	1	1	1	1	0	1	1	P	1	1	0	0	1	1	1	0	1	1	1	1	1	1	0								
Display	Segment							Display	Segment																																																																																																																																																																																								
	a	b		c	d	e	f		g	a	b	c	d	e	f	g																																																																																																																																																																																	
1	0	1		1	0	0	0	0	R	1	1	0	1	1	1	1																																																																																																																																																																																	
2	1	1		0	1	1	0	1	E	1	0	0	1	1	1	1																																																																																																																																																																																	
3	1	1		1	1	0	0	1	n	0	0	1	0	1	0	1																																																																																																																																																																																	
4	0	1		1	0	0	1	1	d	0	1	1	1	1	0	1																																																																																																																																																																																	
5	1	0	1	1	0	1	1	-	0	0	0	0	0	0	1																																																																																																																																																																																		
6	1	0	1	1	1	1	1	r	0	0	0	0	1	1	1																																																																																																																																																																																		
7	1	1	1	0	0	1	0	R	1	1	1	0	1	1	1																																																																																																																																																																																		
8	1	1	1	1	1	1	1	E	1	0	0	1	1	1	0																																																																																																																																																																																		
9	1	1	1	1	0	1	1	P	1	1	0	0	1	1	1																																																																																																																																																																																		
0	1	1	1	1	1	1	0																																																																																																																																																																																										
14	Vss	Vss	+B (10V)																																																																																																																																																																																														
15	TEST	TEST																																																																																																																																																																																															
16	PF0	4G	<ul style="list-style-type: none"> <li>Grid scan data output.</li> </ul> <p>Relationship between scan output and display digits.</p> <table border="1"> <thead> <tr> <th rowspan="2">Grid</th> <th colspan="4">Display digit</th> </tr> <tr> <th>4th digit</th> <th>3rd digit</th> <th>2nd digit</th> <th>1st digit</th> </tr> </thead> <tbody> <tr> <td>1G</td> <td>0</td> <td>0</td> <td>0</td> <td>1</td> </tr> <tr> <td>2G</td> <td>0</td> <td>0</td> <td>1</td> <td>0</td> </tr> <tr> <td>3G</td> <td>0</td> <td>1</td> <td>0</td> <td>0</td> </tr> <tr> <td>4G</td> <td>1</td> <td>0</td> <td>0</td> <td>0</td> </tr> </tbody> </table>	Grid	Display digit				4th digit	3rd digit	2nd digit	1st digit	1G	0	0	0	1	2G	0	0	1	0	3G	0	1	0	0	4G	1	0	0	0																																																																																																																																																																	
Grid	Display digit																																																																																																																																																																																																
	4th digit	3rd digit		2nd digit	1st digit																																																																																																																																																																																												
1G	0	0		0	1																																																																																																																																																																																												
2G	0	0	1	0																																																																																																																																																																																													
3G	0	1	0	0																																																																																																																																																																																													
4G	1	0	0	0																																																																																																																																																																																													
17	PF1	3G																																																																																																																																																																																															
18	PF2	2G																																																																																																																																																																																															
19	PF3	1G																																																																																																																																																																																															
20	PG0	NC	<ul style="list-style-type: none"> <li>Vacant terminals.</li> </ul>																																																																																																																																																																																														
21	PA0	NC																																																																																																																																																																																															
22	PA1	NC																																																																																																																																																																																															
23	PA2	C.RESET	<ul style="list-style-type: none"> <li>Tape counter reset key input.</li> <li>"0 0 0" display at "L" level input.</li> </ul>																																																																																																																																																																																														

Terminal No.	Terminal name	Function name	Functions
24	PA3	NC	<ul style="list-style-type: none"> <li>Vacant terminal</li> </ul>
25	INT	REEL PULSE	<ul style="list-style-type: none"> <li>Reel block pulse input for detection of tape end.</li> <li>Tape counter counts up and down by this pulse. (<math>\pm 1</math> count at input of 8 pulses)</li> <li>Counter is cleared when tape end is detected during REW.</li> </ul>
26	RES	RESET	<ul style="list-style-type: none"> <li>RESET pulse input</li> </ul>
27	VGG	VGG	<ul style="list-style-type: none"> <li>GND (earth)</li> </ul>
28	CLO	CLO	<ul style="list-style-type: none"> <li>Internal clock oscillation</li> </ul>

2.  $\mu$ PD553C-229N (microcomputer) terminal function table

Terminal No.	Terminal name	Function name	Functions																																																																																			
1	CL1	CLOCK	<ul style="list-style-type: none"> <li>LC for clock oscillation is externally attached.</li> </ul>																																																																																			
2	PC0	K0	<ul style="list-style-type: none"> <li>Input terminals for detection of mechanism position through rotary switch mounted on mechanism.</li> <li>Positions of 11 modes are available through "H" and "L" of each port. These modes are encoded to control the mechanism.</li> </ul> <table border="1"> <thead> <tr> <th rowspan="2"></th> <th colspan="6">Reverse</th> <th colspan="5">Forward</th> </tr> <tr> <th>PLAY</th> <th>↔</th> <th>PAUSE &amp; SEARCH</th> <th>↔</th> <th>STOP</th> <th>↔</th> <th>F.F &amp; REW</th> <th>↔</th> <th>PAUSE &amp; SEARCH</th> <th>↔</th> <th>PLAY</th> </tr> </thead> <tbody> <tr> <td>K0</td> <td>0</td> <td>0</td> <td>0</td> <td>1</td> <td>1</td> <td>1</td> <td>1</td> <td>1</td> <td>0</td> <td>0</td> <td>1</td> </tr> <tr> <td>K1</td> <td>1</td> <td>1</td> <td>0</td> <td>0</td> <td>0</td> <td>0</td> <td>1</td> <td>1</td> <td>1</td> <td>0</td> <td>0</td> </tr> <tr> <td>K2</td> <td>0</td> <td>1</td> <td>1</td> <td>1</td> <td>0</td> <td>0</td> <td>0</td> <td>1</td> <td>1</td> <td>1</td> <td>1</td> </tr> <tr> <td>K3</td> <td>1</td> <td>1</td> <td>1</td> <td>1</td> <td>1</td> <td>0</td> <td>0</td> <td>0</td> <td>0</td> <td>0</td> <td>0</td> </tr> <tr> <td>Code</td> <td>A</td> <td>E</td> <td>C</td> <td>D</td> <td>9</td> <td>1</td> <td>3</td> <td>7</td> <td>6</td> <td>4</td> <td>5</td> </tr> </tbody> </table>		Reverse						Forward					PLAY	↔	PAUSE & SEARCH	↔	STOP	↔	F.F & REW	↔	PAUSE & SEARCH	↔	PLAY	K0	0	0	0	1	1	1	1	1	0	0	1	K1	1	1	0	0	0	0	1	1	1	0	0	K2	0	1	1	1	0	0	0	1	1	1	1	K3	1	1	1	1	1	0	0	0	0	0	0	Code	A	E	C	D	9	1	3	7	6	4	5
	Reverse						Forward																																																																															
	PLAY	↔		PAUSE & SEARCH	↔	STOP	↔	F.F & REW	↔	PAUSE & SEARCH	↔	PLAY																																																																										
K0	0	0		0	1	1	1	1	1	0	0	1																																																																										
K1	1	1		0	0	0	0	1	1	1	0	0																																																																										
K2	0	1	1	1	0	0	0	1	1	1	1																																																																											
K3	1	1	1	1	1	0	0	0	0	0	0																																																																											
Code	A	E	C	D	9	1	3	7	6	4	5																																																																											
3	PC1	K1																																																																																				
4	PC2	K2																																																																																				
5	PC3	K3																																																																																				
6	INT	REEL PULSE	<ul style="list-style-type: none"> <li>Input terminal of reel pulse for detection of tape end.</li> <li>Tape end processing is performed when pulse input is lost for 3 seconds during PLAY or REC/PLAY, and for 1 second during F.F/REW or F.F/REW SEARCH.</li> <li>Rewinding from overrun at selection of music and the multi-repeat function are performed with the pulse count of this input terminal.</li> </ul>																																																																																			
7	RES	RESET	<ul style="list-style-type: none"> <li>Microcomputer reset terminal. The microcomputer is reset when the "H" level is input for at least 4 machine cycles (10<math>\mu</math>sec).</li> </ul>																																																																																			
8	PD0	LEADER	<ul style="list-style-type: none"> <li>Input terminal for detecting the leader tape section in tape.</li> <li>Detection of the leader tape begins 10 seconds and 1 second, respectively, after the tape started running during PLAY and REC/PLAY, and during SEARCH.</li> <li>For tapes without leader tapes, the tape is run up to the tape end. At the tape end, the "H" level is output from the PH2 terminal, and reversing takes place through detection of the mode switch.</li> <li>Reversing takes place when the "L" level is input into this input terminal.</li> </ul>																																																																																			
9	PD1	MUSIC	<ul style="list-style-type: none"> <li>Input terminal for detection of the music signal "H", "L" levels.</li> </ul>																																																																																			
10	PD2	MULT1	<ul style="list-style-type: none"> <li>Multi-repeat key input terminal.</li> <li>Key input is assumed at the "L" level input.</li> </ul>																																																																																			
11	PD3	PROT/HEAD	<ul style="list-style-type: none"> <li>Detection of the REC PROTECT switch is performed when the "H" level is output from the PE3 terminal, and detection of the direction of the head is performed when the "L" level is output from the same terminal.</li> <li>When the "H" level is input into this input terminal, REC PROTECT is capable of REC, and the direction of the head becomes forward.</li> </ul>																																																																																			
12	PE0	LINE MUTE	<ul style="list-style-type: none"> <li>Line amplifier muting control output terminal</li> </ul>																																																																																			

Terminal No.	Terminal name	Function name	Functions																																																																																																			
13	PE1	REC MUTE	<ul style="list-style-type: none"> <li>Recording amplifier muting control output terminal.</li> </ul>																																																																																																			
14	PE2	BIAS	<ul style="list-style-type: none"> <li>Bias oscillation circuit control output terminal.</li> </ul>																																																																																																			
15	PE3	MODE	<ul style="list-style-type: none"> <li>Clock output terminal for counter microcomputer control.</li> <li>The PROT/HEAD detection change-over signal of the PD3 terminal is output.</li> </ul>																																																																																																			
16 17 18 19	PF0 PF1 PF2 PF3	DATA0 DATA1 DATA2 DATA3	<ul style="list-style-type: none"> <li>Data output terminals for counter microcomputer control.</li> <li>8-bit data is output from PF0 ~ PF3 in synchronization with the clock of the PE3 terminal.</li> <li>When the PED3 terminal is on the "L" level, the counter counts up when the PF0 terminal is on the "H" level, and counts down when the same terminal is on the "L" level.</li> <li>When the head is on the forward side, "End" is displayed at stopping at the tape end after counting up.</li> <li>"000" is displayed at stopping at the tape end after counting down. This is reversed when the head is on the reverse side.</li> <li>Display by 8-bit data.</li> </ul> <table border="1" style="margin-left: 20px;"> <thead> <tr> <th colspan="8">MODE</th> <th rowspan="2">Micro-computer output</th> <th rowspan="2">Display</th> </tr> <tr> <th colspan="4">0</th> <th colspan="4">1</th> </tr> <tr> <th>D3</th> <th>D2</th> <th>D1</th> <th>D0</th> <th>D3</th> <th>D2</th> <th>D1</th> <th>D0</th> <th></th> </tr> </thead> <tbody> <tr> <td>0</td> <td>0</td> <td>0</td> <td>0/1</td> <td>0</td> <td>0</td> <td>0</td> <td>0</td> <td>-00 -15</td> </tr> <tr> <td>0</td> <td>0</td> <td>0</td> <td>0/1</td> <td>1</td> <td>1</td> <td>1</td> <td>1</td> <td>00 15</td> </tr> <tr> <td>0</td> <td>1</td> <td>0</td> <td>0/1</td> <td>0</td> <td>0</td> <td>0</td> <td>0</td> <td>R-00 R-15</td> </tr> <tr> <td>0</td> <td>1</td> <td>1</td> <td>0/1</td> <td>0</td> <td>0</td> <td>1</td> <td>0</td> <td>End</td> </tr> <tr> <td>1</td> <td>0</td> <td>0</td> <td>0/1</td> <td>0</td> <td>0</td> <td>0</td> <td>0</td> <td>P-00 P-15</td> </tr> <tr> <td>1</td> <td>0</td> <td>1</td> <td>0/1</td> <td colspan="4">(Anything)</td> <td>Counter display</td> </tr> <tr> <td>1</td> <td>1</td> <td>0</td> <td>0/1</td> <td>0</td> <td>0</td> <td>0</td> <td>0</td> <td>R-00 R-15</td> </tr> <tr> <td>1</td> <td>1</td> <td>1</td> <td>0</td> <td colspan="4">(Anything)</td> <td>000</td> </tr> </tbody> </table>	MODE								Micro-computer output	Display	0				1				D3	D2	D1	D0	D3	D2	D1	D0		0	0	0	0/1	0	0	0	0	-00 -15	0	0	0	0/1	1	1	1	1	00 15	0	1	0	0/1	0	0	0	0	R-00 R-15	0	1	1	0/1	0	0	1	0	End	1	0	0	0/1	0	0	0	0	P-00 P-15	1	0	1	0/1	(Anything)				Counter display	1	1	0	0/1	0	0	0	0	R-00 R-15	1	1	1	0	(Anything)				000
MODE								Micro-computer output	Display																																																																																													
0				1																																																																																																		
D3	D2	D1	D0	D3	D2	D1	D0																																																																																															
0	0	0	0/1	0	0	0	0	-00 -15																																																																																														
0	0	0	0/1	1	1	1	1	00 15																																																																																														
0	1	0	0/1	0	0	0	0	R-00 R-15																																																																																														
0	1	1	0/1	0	0	1	0	End																																																																																														
1	0	0	0/1	0	0	0	0	P-00 P-15																																																																																														
1	0	1	0/1	(Anything)				Counter display																																																																																														
1	1	0	0/1	0	0	0	0	R-00 R-15																																																																																														
1	1	1	0	(Anything)				000																																																																																														
20	TEST	TEST	+B (10V)																																																																																																			
21	VSS	VSS	+B (10V)																																																																																																			
22 23	PG0 PG1	RMF RMR	<ul style="list-style-type: none"> <li>Output terminal for reel motor control.</li> <li>The reel motor rotates in the F.F direction when PG0 and PG1 are on the "H" and "L" levels, respectively, and in the REW direction when they are on the "L" and "H" levels, respectively. The reel motor stops when both PG0 and PG1 are on the "L" level.</li> <li>PG0 is used as an output terminal for detection of the mode switch.</li> </ul>																																																																																																			
24 25	PG2 PG3	AMF AMR	<ul style="list-style-type: none"> <li>Output terminals for assist motor control.</li> <li>The mechanism position shifts from the reverse direction to the forward direction when PG2 and PG3 are on the "H" and "L" levels, respectively. Also it shifts from the forward direction to the reverse direction when PG2 and PG3 are on the "L" and "H" levels, respectively. The assist motor stops when both PG2 and PG3 are on the "L" level.</li> </ul>																																																																																																			
26	PH0	OUT-PLAY	<ul style="list-style-type: none"> <li>The "H" level is output during PLAY and REC/PLAY to perform the reel motor voltage change-over.</li> </ul>																																																																																																			

Terminal No.	Terminal name	Function name	Functions
27	PH1	TIMER	<ul style="list-style-type: none"> <li>Output terminal for timer PLAY, REC/PLAY.</li> <li>The "L" level is output for 4 seconds after the power switch is turned to ON, and the "H" level is output when the program makes an input into the main routine after 4 seconds.</li> </ul>
28	PH2	PULSE	<ul style="list-style-type: none"> <li>When tape ended during PLAY, REC/PLAY or in the SEARCH mode, the "H" level is output after 3 seconds during PLAY and REC/PLAY, and after 1 second in the SEARCH mode.</li> <li>The head reverses when the PD0 terminal became the "L" level during output of the "H" level. When the PD0 terminal does not become the "L" level even if output of this terminal lasted 500msec, the mechanism is set to the stop mode, and this terminal also assumes the "L" level.</li> </ul>
29	PH3	PLAY.S	<ul style="list-style-type: none"> <li>Output terminal for system control one-touch system.</li> <li>The "H" level is output when this unit assumes a PLAY state through DRPS, etc. to change over the function of the one-touch system. The "L" level is assumed when this unit was set to the stop mode.</li> </ul>
30	PI0	PAUSE IND.	<ul style="list-style-type: none"> <li>The PAUSE indicator control output terminal. The "H" level is output in the PAUSE mode.</li> <li>500msec and 50msec pulses are periodically output during AUTO REC MUTE and in the TAPE STANDBY mode, respectively.</li> <li>The "H" level is output when the PAUSE key is pressed in the SEARCH mode.</li> </ul>
31	PI1	PLAY IND.	<ul style="list-style-type: none"> <li>The PLAY indicator control output terminal. The "H" level is output while the reel motor is stopped.</li> <li>Pulses are output in synchronization with reel pulses in the PLAY mode.</li> <li>125msec pulses are synchronously output if the timer switch is turned to ON for 4 seconds after turning the power switch to ON.</li> <li>50msec pulses are periodically output in the SEARCH mode.</li> </ul>
32	PI2	REC IND.	<ul style="list-style-type: none"> <li>The REC indicator and REC/PLAY head change-over control output terminal.</li> <li>The "H" level is output during REC MONITOR and REC.</li> <li>The "H" level is output if the timer switch is turned to REC/PLAY for 4 seconds after turning the power switch to ON. The "L" level is output when the REC prevention nail of cassette tape is broken when detection of the REC PROTECT switch is performed.</li> <li>This terminal assumes the "L" level when the head reversed toward the forward side during recording on the reverse side.</li> </ul>
33 34 35 36 37 38 39 40	PA0 PA1 PA2 PA3 PB0 PB1 PB2 PB3	MUTE REC PAUSE STOP REW F.F R-PLAY F-PLAY	<ul style="list-style-type: none"> <li>Control key input terminal.</li> <li>Key input is assumed at the "L" level.</li> <li>The PA0 terminal is jointly used for the input of the mute and DRPS (memory) keys.</li> <li>Scanplay key input processing is assumed when both the PB2 and PB3 terminals assumed the "L" level.</li> </ul>
41	VGG	VGG	GND (earth)
42	CLO	CLOCK	<ul style="list-style-type: none"> <li>LC for clock oscillation is externally attached.</li> </ul>

1.  $\mu$ PD554C-109M (Zählermikrocomputer) Klemmenfunktionstabelle

Klemmen-Nr.	Klemmen-bezeichnung	Funktions-bezeichnung	Funktionen																																																																																																																																																																																														
1	CL1	CL1	<ul style="list-style-type: none"> <li>Interne Zeitimpulse</li> </ul>																																																																																																																																																																																														
2	PC0	D3	<ul style="list-style-type: none"> <li>Dateneingang für Anzeigenröhrensteuerung</li> <li>Speisen von 8 Bit-Daten (mit PDO-Eingang-Uhr synchronisiert) in PC0 ~ PC3. Beziehung zwischen eingegebenen Daten und Anzeige.</li> </ul> <table border="1"> <thead> <tr> <th colspan="4">Bei PDO = "L"-Pegel</th> <th colspan="4">Bei PDO = "H"-Pegel</th> <th rowspan="2">Anzeige</th> </tr> <tr> <th>D3</th> <th>D2</th> <th>D1</th> <th>D0</th> <th>D3</th> <th>D2</th> <th>D1</th> <th>D0</th> </tr> </thead> <tbody> <tr> <td>0</td> <td>0</td> <td>0</td> <td>*1</td> <td>0</td> <td>(~ F)</td> <td></td> <td></td> <td>-00 (~ 15)</td> </tr> <tr> <td>0</td> <td>0</td> <td>1</td> <td>*1</td> <td>0</td> <td>(~ F)</td> <td></td> <td></td> <td>00 (~ 15)</td> </tr> <tr> <td>0</td> <td>1</td> <td>0</td> <td>*1</td> <td>0</td> <td>(~ F)</td> <td></td> <td></td> <td>R-00 (~ 15)</td> </tr> <tr> <td></td> <td></td> <td></td> <td></td> <td>0</td> <td>0</td> <td>1</td> <td>0</td> <td>End</td> </tr> <tr> <td></td> <td></td> <td></td> <td></td> <td>1</td> <td>0</td> <td>0</td> <td>0</td> <td>R</td> </tr> <tr> <td></td> <td></td> <td></td> <td></td> <td>1</td> <td>0</td> <td>1</td> <td>0</td> <td>R End</td> </tr> <tr> <td></td> <td></td> <td></td> <td></td> <td>1</td> <td>1</td> <td>0</td> <td>0</td> <td>R-</td> </tr> <tr> <td></td> <td></td> <td></td> <td></td> <td>1</td> <td>0</td> <td>0</td> <td>*1</td> <td>R-00 (~ 15)</td> </tr> <tr> <td></td> <td></td> <td></td> <td></td> <td>1</td> <td>0</td> <td>1</td> <td>*1</td> <td>Zähler</td> </tr> <tr> <td></td> <td></td> <td></td> <td></td> <td>1</td> <td>1</td> <td>0</td> <td>*1</td> <td>R-00 (~ 15)</td> </tr> <tr> <td></td> <td></td> <td></td> <td></td> <td>1</td> <td>1</td> <td>1</td> <td>0</td> <td>Keine Änderung (Nur Bandzählwerk wird rückgestellt.)</td> </tr> </tbody> </table> <p>*1: "1" zeigt Vorwärtszählen und "0" zeigt Rückwärtszählen bei den Bandzählwerk-Steuerungsdaten an. *2: Beliebig.</p>	Bei PDO = "L"-Pegel				Bei PDO = "H"-Pegel				Anzeige	D3	D2	D1	D0	D3	D2	D1	D0	0	0	0	*1	0	(~ F)			-00 (~ 15)	0	0	1	*1	0	(~ F)			00 (~ 15)	0	1	0	*1	0	(~ F)			R-00 (~ 15)					0	0	1	0	End					1	0	0	0	R					1	0	1	0	R End					1	1	0	0	R-					1	0	0	*1	R-00 (~ 15)					1	0	1	*1	Zähler					1	1	0	*1	R-00 (~ 15)					1	1	1	0	Keine Änderung (Nur Bandzählwerk wird rückgestellt.)																																																																										
Bei PDO = "L"-Pegel				Bei PDO = "H"-Pegel				Anzeige																																																																																																																																																																																									
D3	D2	D1		D0	D3	D2	D1		D0																																																																																																																																																																																								
0	0	0		*1	0	(~ F)			-00 (~ 15)																																																																																																																																																																																								
0	0	1		*1	0	(~ F)			00 (~ 15)																																																																																																																																																																																								
0	1	0		*1	0	(~ F)			R-00 (~ 15)																																																																																																																																																																																								
				0	0	1	0	End																																																																																																																																																																																									
				1	0	0	0	R																																																																																																																																																																																									
				1	0	1	0	R End																																																																																																																																																																																									
				1	1	0	0	R-																																																																																																																																																																																									
				1	0	0	*1	R-00 (~ 15)																																																																																																																																																																																									
				1	0	1	*1	Zähler																																																																																																																																																																																									
				1	1	0	*1	R-00 (~ 15)																																																																																																																																																																																									
				1	1	1	0	Keine Änderung (Nur Bandzählwerk wird rückgestellt.)																																																																																																																																																																																									
7	PD1	a	<ul style="list-style-type: none"> <li>Segmentsteuerungsdatenausgang. Beziehung zwischen Ausgangsdaten und Anzeige.</li> </ul> <table border="1"> <thead> <tr> <th rowspan="2">Anzeige</th> <th colspan="7">Segment</th> <th rowspan="2">Anzeige</th> <th colspan="7">Segment</th> </tr> <tr> <th>a</th> <th>b</th> <th>c</th> <th>d</th> <th>e</th> <th>f</th> <th>g</th> <th>a</th> <th>b</th> <th>c</th> <th>d</th> <th>e</th> <th>f</th> <th>g</th> </tr> </thead> <tbody> <tr> <td>1</td> <td>0</td> <td>1</td> <td>1</td> <td>0</td> <td>0</td> <td>0</td> <td>0</td> <td>R</td> <td>1</td> <td>1</td> <td>0</td> <td>1</td> <td>1</td> <td>1</td> <td>1</td> </tr> <tr> <td>2</td> <td>1</td> <td>1</td> <td>0</td> <td>1</td> <td>1</td> <td>0</td> <td>1</td> <td>E</td> <td>1</td> <td>0</td> <td>0</td> <td>1</td> <td>1</td> <td>1</td> <td>1</td> </tr> <tr> <td>3</td> <td>1</td> <td>1</td> <td>1</td> <td>1</td> <td>0</td> <td>0</td> <td>1</td> <td>n</td> <td>0</td> <td>0</td> <td>1</td> <td>0</td> <td>1</td> <td>0</td> <td>1</td> </tr> <tr> <td>4</td> <td>0</td> <td>1</td> <td>1</td> <td>0</td> <td>0</td> <td>1</td> <td>1</td> <td>d</td> <td>0</td> <td>1</td> <td>1</td> <td>1</td> <td>1</td> <td>0</td> <td>1</td> </tr> <tr> <td>5</td> <td>1</td> <td>0</td> <td>1</td> <td>1</td> <td>0</td> <td>1</td> <td>1</td> <td>-</td> <td>0</td> <td>0</td> <td>0</td> <td>0</td> <td>0</td> <td>0</td> <td>1</td> </tr> <tr> <td>6</td> <td>1</td> <td>0</td> <td>1</td> <td>1</td> <td>1</td> <td>1</td> <td>1</td> <td>r</td> <td>0</td> <td>0</td> <td>0</td> <td>0</td> <td>1</td> <td>1</td> <td>1</td> </tr> <tr> <td>7</td> <td>1</td> <td>1</td> <td>1</td> <td>0</td> <td>0</td> <td>1</td> <td>0</td> <td>R</td> <td>1</td> <td>1</td> <td>1</td> <td>0</td> <td>1</td> <td>1</td> <td>1</td> </tr> <tr> <td>8</td> <td>1</td> <td>1</td> <td>1</td> <td>1</td> <td>1</td> <td>1</td> <td>1</td> <td>E</td> <td>1</td> <td>0</td> <td>0</td> <td>1</td> <td>1</td> <td>1</td> <td>0</td> </tr> <tr> <td>9</td> <td>1</td> <td>1</td> <td>1</td> <td>1</td> <td>0</td> <td>1</td> <td>1</td> <td>P</td> <td>1</td> <td>1</td> <td>0</td> <td>0</td> <td>1</td> <td>1</td> <td>1</td> </tr> <tr> <td>0</td> <td>1</td> <td>1</td> <td>1</td> <td>1</td> <td>1</td> <td>1</td> <td>0</td> <td></td> <td></td> <td></td> <td></td> <td></td> <td></td> <td></td> <td></td> </tr> </tbody> </table>	Anzeige	Segment							Anzeige	Segment							a	b	c	d	e	f	g	a	b	c	d	e	f	g	1	0	1	1	0	0	0	0	R	1	1	0	1	1	1	1	2	1	1	0	1	1	0	1	E	1	0	0	1	1	1	1	3	1	1	1	1	0	0	1	n	0	0	1	0	1	0	1	4	0	1	1	0	0	1	1	d	0	1	1	1	1	0	1	5	1	0	1	1	0	1	1	-	0	0	0	0	0	0	1	6	1	0	1	1	1	1	1	r	0	0	0	0	1	1	1	7	1	1	1	0	0	1	0	R	1	1	1	0	1	1	1	8	1	1	1	1	1	1	1	E	1	0	0	1	1	1	0	9	1	1	1	1	0	1	1	P	1	1	0	0	1	1	1	0	1	1	1	1	1	1	0								
Anzeige	Segment							Anzeige	Segment																																																																																																																																																																																								
	a	b		c	d	e	f		g	a	b	c	d	e	f	g																																																																																																																																																																																	
1	0	1		1	0	0	0	0	R	1	1	0	1	1	1	1																																																																																																																																																																																	
2	1	1		0	1	1	0	1	E	1	0	0	1	1	1	1																																																																																																																																																																																	
3	1	1		1	1	0	0	1	n	0	0	1	0	1	0	1																																																																																																																																																																																	
4	0	1	1	0	0	1	1	d	0	1	1	1	1	0	1																																																																																																																																																																																		
5	1	0	1	1	0	1	1	-	0	0	0	0	0	0	1																																																																																																																																																																																		
6	1	0	1	1	1	1	1	r	0	0	0	0	1	1	1																																																																																																																																																																																		
7	1	1	1	0	0	1	0	R	1	1	1	0	1	1	1																																																																																																																																																																																		
8	1	1	1	1	1	1	1	E	1	0	0	1	1	1	0																																																																																																																																																																																		
9	1	1	1	1	0	1	1	P	1	1	0	0	1	1	1																																																																																																																																																																																		
0	1	1	1	1	1	1	0																																																																																																																																																																																										
14	Vss	Vss	+B (10V)																																																																																																																																																																																														
15	TEST	TEST																																																																																																																																																																																															
16	PF0	4G	<ul style="list-style-type: none"> <li>Gitterabtastungsdatenausgang. Beziehung zwischen Abtastungsausgang und Anzeigedigits.</li> </ul> <table border="1"> <thead> <tr> <th rowspan="2">Anzeigedigits</th> <th colspan="4">Gitter</th> </tr> <tr> <th>4. Digit</th> <th>3. Digit</th> <th>2. Digit</th> <th>1. Digit</th> </tr> </thead> <tbody> <tr> <td>1G</td> <td>0</td> <td>0</td> <td>0</td> <td>1</td> </tr> <tr> <td>2G</td> <td>0</td> <td>0</td> <td>1</td> <td>0</td> </tr> <tr> <td>3G</td> <td>0</td> <td>1</td> <td>0</td> <td>0</td> </tr> <tr> <td>4G</td> <td>1</td> <td>0</td> <td>0</td> <td>0</td> </tr> </tbody> </table>	Anzeigedigits	Gitter				4. Digit	3. Digit	2. Digit	1. Digit	1G	0	0	0	1	2G	0	0	1	0	3G	0	1	0	0	4G	1	0	0	0																																																																																																																																																																	
Anzeigedigits	Gitter																																																																																																																																																																																																
	4. Digit	3. Digit		2. Digit	1. Digit																																																																																																																																																																																												
1G	0	0		0	1																																																																																																																																																																																												
2G	0	0	1	0																																																																																																																																																																																													
3G	0	1	0	0																																																																																																																																																																																													
4G	1	0	0	0																																																																																																																																																																																													
17	PF1	3G																																																																																																																																																																																															
18	PF2	2G																																																																																																																																																																																															
19	PF3	1G																																																																																																																																																																																															
20	PG0	NC	<ul style="list-style-type: none"> <li>Freie Buchsen.</li> </ul>																																																																																																																																																																																														
21	PA0	NC																																																																																																																																																																																															
22	PA1	NC																																																																																																																																																																																															

Klemmen-Nr.	Klemmen-bezeichnung	Funktions-bezeichnung	Funktionen
23	PA2	C.RESET	<ul style="list-style-type: none"> <li>Eingang für Bandzählwerkrückstellung.</li> <li>"0 0 0" Anzeige bis "L"-Pegeleingang.</li> </ul>
24	PA3	NC	<ul style="list-style-type: none"> <li>Freie Buchse</li> </ul>
25	INT	REEL PULSE	<ul style="list-style-type: none"> <li>Wickeltellerblockimpulseingang für Feststellen des Bandendes.</li> <li>Das Bandzählwerk zählt aufgrund dieses Impulses vorwärts oder rückwärts. (<math>\pm 1</math> Zählung bei Eingang von 8 Impulsen)</li> <li>Das Bandzählwerk wird rückgestellt, wenn das Bandende während des Rücklaufs festgestellt wird.</li> </ul>
26	RES	RESET	<ul style="list-style-type: none"> <li>Rückstellungsimpulseingang</li> </ul>
27	VGG	VGG	<ul style="list-style-type: none"> <li>GND (Erde)</li> </ul>
28	CLO	CLO	<ul style="list-style-type: none"> <li>Interne Zeitimpulse</li> </ul>

2.  $\mu$ PD553C-229N (Mikrocomputer) Klemmenfunktionstabelle

Klemmen-Nr.	Klemmen-bezeichnung	Funktions-bezeichnung	Funktionen																																																																																			
1	CL1	CLOCK	<ul style="list-style-type: none"> <li>LC für Zeitimpulsgeber ist extern angebracht.</li> </ul>																																																																																			
2	PC0	K0	<ul style="list-style-type: none"> <li>Eingangsklemmen für das Feststellen der Mechanismusposition durch den am Mechanismus angebrachten Drehschalter.</li> <li>Die Position von 11 Betriebsarten liegen durch "H" und "L" von jedem Port vor. Diese Betriebsarten sind für die Mechanismussteuerung codiert.</li> </ul> <table border="1"> <thead> <tr> <th rowspan="2"></th> <th colspan="6">Rücklauf</th> <th colspan="5">Vorlauf</th> </tr> <tr> <th>PLAY</th> <th>↔</th> <th>PAUSE &amp; SEARCH</th> <th>↔</th> <th>STOP</th> <th>↔</th> <th>F.F &amp; REW</th> <th>↔</th> <th>PAUSE &amp; SEARCH</th> <th>↔</th> <th>PLAY</th> </tr> </thead> <tbody> <tr> <td>K0</td> <td>0</td> <td>0</td> <td>0</td> <td>1</td> <td>1</td> <td>1</td> <td>1</td> <td>1</td> <td>0</td> <td>0</td> <td>1</td> </tr> <tr> <td>K1</td> <td>1</td> <td>1</td> <td>0</td> <td>0</td> <td>0</td> <td>0</td> <td>1</td> <td>1</td> <td>1</td> <td>0</td> <td>0</td> </tr> <tr> <td>K2</td> <td>0</td> <td>1</td> <td>1</td> <td>1</td> <td>0</td> <td>0</td> <td>0</td> <td>1</td> <td>1</td> <td>1</td> <td>1</td> </tr> <tr> <td>K3</td> <td>1</td> <td>1</td> <td>1</td> <td>1</td> <td>1</td> <td>0</td> <td>0</td> <td>0</td> <td>0</td> <td>0</td> <td>0</td> </tr> <tr> <td>Code</td> <td>A</td> <td>E</td> <td>C</td> <td>D</td> <td>9</td> <td>1</td> <td>3</td> <td>7</td> <td>6</td> <td>4</td> <td>5</td> </tr> </tbody> </table>		Rücklauf						Vorlauf					PLAY	↔	PAUSE & SEARCH	↔	STOP	↔	F.F & REW	↔	PAUSE & SEARCH	↔	PLAY	K0	0	0	0	1	1	1	1	1	0	0	1	K1	1	1	0	0	0	0	1	1	1	0	0	K2	0	1	1	1	0	0	0	1	1	1	1	K3	1	1	1	1	1	0	0	0	0	0	0	Code	A	E	C	D	9	1	3	7	6	4	5
	Rücklauf						Vorlauf																																																																															
	PLAY	↔		PAUSE & SEARCH	↔	STOP	↔	F.F & REW	↔	PAUSE & SEARCH	↔	PLAY																																																																										
K0	0	0		0	1	1	1	1	1	0	0	1																																																																										
K1	1	1		0	0	0	0	1	1	1	0	0																																																																										
K2	0	1	1	1	0	0	0	1	1	1	1																																																																											
K3	1	1	1	1	1	0	0	0	0	0	0																																																																											
Code	A	E	C	D	9	1	3	7	6	4	5																																																																											
6	INT	REEL PULSE	<ul style="list-style-type: none"> <li>Eingangsklemme des Wickeltellerimpulses für Feststellen des Bandendes.</li> <li>Die Bandendinformation wird bei Ausfall des Impulseinganges für drei Sekunden während der Wiedergabe oder Aufnahme/Wiedergabe, und für eine Sekunde während Schnellvorlauf/Rücklauf oder Schnellvorlauf/Rücklauf-Suchlauf, verarbeitet.</li> <li>Rücklauf bei nicht rechtzeitigem Stoppen im Falle von Scanplay-Musikwahl und Multi-Repeat-Funktion erfolgt mittels Impulzzählung über diese Eingangsklemme.</li> </ul>																																																																																			
7	RES	RESET	<ul style="list-style-type: none"> <li>Mikrocomputerrückstellungsklemme. Der Mikrocomputer wird bei Eingang des "H"-Pegels für mindestens vier Takte (10<math>\mu</math>sec) rückgestellt.</li> </ul>																																																																																			
8	PDO	LEADER	<ul style="list-style-type: none"> <li>Eingangsklemme für das Feststellen des Vorspannbandes.</li> <li>Das Feststellen des Vorspannbandes beginnt 10 Sekunden bzw. 1 Sekunde nach Beginn des Bandlaufes bei Wiedergabe und Aufnahme/Wiedergabe sowie Suchlauf.</li> <li>Bei Bändern ohne Vorspannband läuft das Band bis zum Bandende. Bei Erreichen des Bandendes erfolgt Ausgang des "H"-Pegels durch die PH2-Klemme und Rücklauf erfolgt durch den Betriebsartschalter.</li> <li>Rücklauf erfolgt bei Eingabe des "L"-Pegels in diese Eingangsklemme.</li> </ul>																																																																																			
9	PD1	MUSIC	<ul style="list-style-type: none"> <li>Eingangsklemme für Feststellen der Musiksignal-H- und L-Pegel.</li> </ul>																																																																																			
10	PD2	MULT1	<ul style="list-style-type: none"> <li>Multi-Repeat-Eingangsklemme.</li> <li>Der Eingang erfolgt bei "L"-Pegeleingang.</li> </ul>																																																																																			
11	PD3	PROT/HEAD	<ul style="list-style-type: none"> <li>Das Feststellen des REC PROTECT-Schalters erfolgt bei Ausgang des "H"-Pegels von der PE3-Klemme und das Feststellen der Kopfrichtung erfolgt bei Ausgang des "L"-Pegels von der gleichen Klemme.</li> <li>Wenn Eingang des "H"-Pegels in diese Eingangsklemme erfolgt, ist der REC PROTECT-Schalter für Aufnahme eingestellt und der Tonkopf dreht sich in Vorwärtsrichtung.</li> </ul>																																																																																			

Klemmen-Nr.	Klemmen-bezeichnung	Funktions-bezeichnung	Funktionen																																																																																																																																															
12	PE0	LINE MUTE	• Line-Verstärker-Mutingsteuerungs-Ausgangsklemme.																																																																																																																																															
13	PE1	REC MUTE	• Aufnahmeverstärker-Mutingsteuerungs-Ausgangsklemme.																																																																																																																																															
14	PE2	BIAS	• Vormagnetisierungs-Oszillationssteuerungs-Ausgangsklemme.																																																																																																																																															
15	PE3	MODE	<ul style="list-style-type: none"> <li>• Zeitgeberausgangsklemme für Bandzählwerk-Mikrocomputersteuerung.</li> <li>• Ausgang des PROT/HEAD-Umschaltsignals der PD3-Klemme.</li> </ul>																																																																																																																																															
16 17 18 19	PF0 PF1 PF2 PF3	DATA0 DATA1 DATA2 DATA3	<ul style="list-style-type: none"> <li>• Datenausgangsklemmen für Bandzählwerk-Mikrocomputersteuerung.</li> <li>• 8-Bit-Daten-Ausgang von PF0 ~ PF3 synchron mit dem Zeitgeber der PE3-Klemme.</li> <li>• Wenn sich die PED3-Klemme auf dem "L"-Pegel befindet, zählt das Bandzählwerk vorwärts, sofern sich die PF0-Klemme auf dem "H"-Pegel befindet, und zählt zurück, wenn sich die gleiche Klemme auf dem "L"-Pegel befindet.</li> <li>• Wenn der Tonkopf sich an der vorderen Seite befindet, erscheint bei Bandendestopp nach dem Vorwärtszählen die Anzeige "End". "000" erscheint bei Bandendestopp nach dem Rückwärtszählen. Dies wird umgekehrt, wenn sich der Tonkopf an der hinteren Seite befindet.</li> <li>• Anzeige durch 8-Bit-Daten.</li> </ul> <table border="1" style="margin-left: 20px;"> <thead> <tr> <th colspan="8">Betriebsart</th> <th rowspan="2">Mikro-computer-Ausgang</th> </tr> <tr> <th colspan="4">0</th> <th colspan="4">1</th> </tr> <tr> <th>D3</th> <th>D2</th> <th>D1</th> <th>D0</th> <th>D3</th> <th>D2</th> <th>D1</th> <th>D0</th> <th>Anzeige</th> </tr> </thead> <tbody> <tr> <td>0</td> <td>0</td> <td>0</td> <td>0/1</td> <td>0</td> <td>0</td> <td>0</td> <td>0</td> <td>00 }</td> </tr> <tr> <td></td> <td></td> <td></td> <td></td> <td>1</td> <td>1</td> <td>1</td> <td>1</td> <td>-15</td> </tr> <tr> <td>0</td> <td>0</td> <td>0</td> <td>0/1</td> <td>0</td> <td>0</td> <td>0</td> <td>0</td> <td>00 }</td> </tr> <tr> <td></td> <td></td> <td></td> <td></td> <td>1</td> <td>1</td> <td>1</td> <td>1</td> <td>15</td> </tr> <tr> <td>0</td> <td>1</td> <td>0</td> <td>0/1</td> <td>0</td> <td>0</td> <td>0</td> <td>0</td> <td>R-00 }</td> </tr> <tr> <td></td> <td></td> <td></td> <td></td> <td>1</td> <td>1</td> <td>1</td> <td>1</td> <td>R-15</td> </tr> <tr> <td>0</td> <td>1</td> <td>1</td> <td>0/1</td> <td>0</td> <td>0</td> <td>1</td> <td>0</td> <td>End</td> </tr> <tr> <td>1</td> <td>0</td> <td>0</td> <td>0/1</td> <td>0</td> <td>0</td> <td>0</td> <td>0</td> <td>P-00 }</td> </tr> <tr> <td></td> <td></td> <td></td> <td></td> <td>1</td> <td>1</td> <td>1</td> <td>1</td> <td>P-15</td> </tr> <tr> <td>1</td> <td>0</td> <td>1</td> <td>0/1</td> <td colspan="4">(Beliebig)</td> <td>Bandzählwerkanzeige</td> </tr> <tr> <td>1</td> <td>1</td> <td>0</td> <td>0/1</td> <td>0</td> <td>0</td> <td>0</td> <td>0</td> <td>R-00 }</td> </tr> <tr> <td></td> <td></td> <td></td> <td></td> <td>1</td> <td>1</td> <td>1</td> <td>1</td> <td>R-15</td> </tr> <tr> <td>1</td> <td>1</td> <td>1</td> <td>0</td> <td colspan="4">(Beliebig)</td> <td>000</td> </tr> </tbody> </table>	Betriebsart								Mikro-computer-Ausgang	0				1				D3	D2	D1	D0	D3	D2	D1	D0	Anzeige	0	0	0	0/1	0	0	0	0	00 }					1	1	1	1	-15	0	0	0	0/1	0	0	0	0	00 }					1	1	1	1	15	0	1	0	0/1	0	0	0	0	R-00 }					1	1	1	1	R-15	0	1	1	0/1	0	0	1	0	End	1	0	0	0/1	0	0	0	0	P-00 }					1	1	1	1	P-15	1	0	1	0/1	(Beliebig)				Bandzählwerkanzeige	1	1	0	0/1	0	0	0	0	R-00 }					1	1	1	1	R-15	1	1	1	0	(Beliebig)				000
Betriebsart								Mikro-computer-Ausgang																																																																																																																																										
0				1																																																																																																																																														
D3	D2	D1	D0	D3	D2	D1	D0	Anzeige																																																																																																																																										
0	0	0	0/1	0	0	0	0	00 }																																																																																																																																										
				1	1	1	1	-15																																																																																																																																										
0	0	0	0/1	0	0	0	0	00 }																																																																																																																																										
				1	1	1	1	15																																																																																																																																										
0	1	0	0/1	0	0	0	0	R-00 }																																																																																																																																										
				1	1	1	1	R-15																																																																																																																																										
0	1	1	0/1	0	0	1	0	End																																																																																																																																										
1	0	0	0/1	0	0	0	0	P-00 }																																																																																																																																										
				1	1	1	1	P-15																																																																																																																																										
1	0	1	0/1	(Beliebig)				Bandzählwerkanzeige																																																																																																																																										
1	1	0	0/1	0	0	0	0	R-00 }																																																																																																																																										
				1	1	1	1	R-15																																																																																																																																										
1	1	1	0	(Beliebig)				000																																																																																																																																										
20	TEST	TEST	+B (10V)																																																																																																																																															
21	VSS	VSS	+B (10V)																																																																																																																																															
22 23	PG0 PG1	RMF RMR	<ul style="list-style-type: none"> <li>• Ausgangsklemme für Wickeltellermotorsteuerung.</li> <li>• Der Wickeltellermotor rotiert in der Schnell-Vorlaufriechung, wenn PG0 and PG1 sich auf dem "H"-Pegel bzw. "L"-Pegel befinden. Er rotiert in Rücklaufriechung, wenn sie sich auf dem "L" bzw. "H"-Pegel befinden. Der Wickeltellermotor stoppt, wenn sich PG0 sowie PG1 auf dem "L"-Pegel befinden.</li> <li>• PG0 wird als Ausgangsklemme für das Feststellen des Betriebsartschalters verwendet.</li> </ul>																																																																																																																																															
24 25	PG2 PG3	AMF AMR	<ul style="list-style-type: none"> <li>• Ausgangsklemmen für die Hilfsmotorsteuerung.</li> <li>• Die Mechanismusposition ändert sich von der Rücklaufriechung auf Vorlaufriechung, wenn PG2 und PG3 sich auf den "H" bzw. "L"-Pegeln befinden. Sie ändert sich außerdem von Vorlaufriechung auf Rücklaufriechung, wenn PG2 und PG3 sich auf den "L"-bzw. "H"-Pegeln befinden. Der Hilfsmotor stoppt, wenn PG2 sowie PG3 sich auf dem "L"-Pegel befinden.</li> </ul>																																																																																																																																															

Klemmen-Nr.	Klemmen-bezeichnung	Funktions-bezeichnung	Funktionen
26	PH0	OUT-PLAY	• Ausgang des "H"-Pegels erfolgt während der Wiedergabe und Aufnahme/Wiedergabe zur Umschaltung der Wickeltellermotorspannung.
27	PH1	TIMER	<ul style="list-style-type: none"> <li>• Ausgangsbuchse für den Wiedergabe-, Aufnahme/Wiedergabe-Zeitschalter.</li> <li>• Der Ausgang des "L"-Pegels erfolgt für vier Sekunden nach dem Einschalten des Netzschalters; der Ausgang des "H"-Pegels erfolgt, wenn das Programm einen Eingang in das Hauptprogramm nach vier Sekunden durchführt.</li> </ul>
28	PH2	PULSE	<ul style="list-style-type: none"> <li>• Bei Erreichen des Bandendes während der Wiedergabe, Aufnahme/Wiedergabe oder in Suchlauffunktion, erfolgt Ausgang des "H"-Pegels nach drei Sekunden während der Wiedergabe oder Aufnahme/Wiedergabe und nach einer Sekunde bei Suchlauffunktion.</li> <li>• Die Kopfrotation wird umgekehrt wenn die PD0-Klemme während des "H"-Pegelausgangs den "L"-Pegel erreicht. Wenn die PD0-Klemme nicht den "L"-Pegel erreicht, selbst wenn der Ausgang dieser Klemme 500msec dauert, stellt sich der Mechanismus auf Stoppfunktion ein und die Klemme nimmt den "L"-Pegel ein.</li> </ul>
29	PH3	PLAY.S	• Ausgangsklemme für Antippsteuerung des Systems. Es erfolgt "H"-Pegelausgang, wenn das Gerät durch DRPS usw. auf Wiedergabefunktion geschaltet wird. Der "L"-Pegel wird eingestellt, wenn das Gerät auf Stoppfunktion geschaltet wird.
30	PI0	PAUSE IND.	<ul style="list-style-type: none"> <li>• Pause-Anzeige-Ausgangsklemme. Bei Pausefunktion erfolgt "H"-Pegelausgang.</li> <li>• Ausgang von 500msec and 50msec erfolgt periodisch bei Betätigung der AUTO REC MUTE-Taste bzw. bei Abspielbereitschaft.</li> <li>• Ausgang des "H"-Pegels erfolgt bei Betätigung der Pausetaste in Suchlauffunktion.</li> </ul>
31	PI1	PLAY IND.	<ul style="list-style-type: none"> <li>• Wiedergabe-Anzeige-Ausgangsklemme. Es erfolgt "H"-Pegelausgang, während der Wickeltellermotor steht.</li> <li>• Der Impulsausgang erfolgt synchron mit den Wickeltellerimpulsen bei Wiedergabefunktion.</li> <li>• Wenn nach dem Stellen des Netzschalters auf ON (EIN) der Zeitgeberschalter vier Sekunden lang eingeschaltet wird, erfolgt Synchronausgang von 125msec Impulsen.</li> <li>• Bei Suchlauf erfolgt periodischer Ausgang von 50msec Impulsen.</li> </ul>
32	PI2	REC IND.	<ul style="list-style-type: none"> <li>• Aufnahme-Anzeige- und Aufsprech/Wiedergabekopfumschaltungs-Ausgangsklemme.</li> <li>• Es erfolgt "H"-Pegelausgang bei Betätigung der Tasten REC MONITOR und REC.</li> <li>• Wenn nach dem Einschalten des Netzschalters der Zeitgeberschalter für vier Sekunden auf REC/PLAY gestellt wird, erfolgt "H"-Pegelausgang. "L"-Pegelausgang erfolgt, wenn die Lasche für Aufnahmeschutz herausgebrochen ist und Feststellen des REC PROTECT-Schalters durchgeführt wird.</li> <li>• Diese Klemme nimmt den "L"-Pegel bei Umkehr des Tonkopfes zur vorderen Seite, während der Aufnahme auf der hinteren Seite ein.</li> </ul>
33 34 35 36 37 38 39 40	PA0 PA1 PA2 PA3 PB0 PB1 PB2 PB3	MUTE REC PAUSE STOP REW F.F R-PLAY F-PLAY	<ul style="list-style-type: none"> <li>• Tasten-Eingangsklemmen.</li> <li>• Die Tasteneingabe erfolgt bei "L"-Pegel.</li> <li>• Die PA0-Klemme wird für den Eingang der Mute- und DRPS-(Speicher)-Tasten verwendet.</li> <li>• Der Scanplaytasteneingang wird verarbeitet, wenn die PB2- und PB3-Klemmen den "L"-Pegel angenommen haben.</li> </ul>
41	VGG	VGG	GND (Erde)
42	CLO	CLOCK	• LC für Zeitgeberimpuls wird extern angebracht.



1.  $\mu$ PD554C-109M Table de fonction des bornes (micro-ordinateur compteur)

N° de borne	Nom de borne	Désignation de fonction	Fonctions																																																																																																																																																																																														
1	CL1	CL1	<ul style="list-style-type: none"> <li>Oscillation d'horloge interne.</li> </ul>																																																																																																																																																																																														
2	PC0	D3	<ul style="list-style-type: none"> <li>Entrée de donnée pour contrôle tube d'affichage.</li> <li>Prendre les données à 8 bits synchronisées avec l'horloge d'entrée PD0 en PC0 ~ PC3. Relation entre donnée d'entrée et affichage.</li> </ul> <table border="1"> <thead> <tr> <th colspan="4">Au niveau PD0 = "L"</th> <th colspan="4">Au niveau PD0 = "H"</th> <th rowspan="2">Affichage</th> </tr> <tr> <th>D3</th> <th>D2</th> <th>D1</th> <th>D0</th> <th>D3</th> <th>D2</th> <th>D1</th> <th>D0</th> </tr> </thead> <tbody> <tr> <td>0</td> <td>0</td> <td>0</td> <td>*1</td> <td colspan="4">0 (~ F)</td> <td>-00 (~ 15)</td> </tr> <tr> <td>0</td> <td>0</td> <td>1</td> <td>*1</td> <td colspan="4">0 (~ F)</td> <td>00 (~ 15)</td> </tr> <tr> <td>0</td> <td>1</td> <td>0</td> <td>*1</td> <td colspan="4">0 (~ F)</td> <td>R-00 (~ 15)</td> </tr> <tr> <td></td> <td></td> <td></td> <td></td> <td>0</td> <td>0</td> <td>1</td> <td>0</td> <td>End</td> </tr> <tr> <td></td> <td></td> <td></td> <td></td> <td>1</td> <td>0</td> <td>0</td> <td>0</td> <td>R</td> </tr> <tr> <td></td> <td></td> <td></td> <td></td> <td>1</td> <td>0</td> <td>1</td> <td>0</td> <td>R End</td> </tr> <tr> <td></td> <td></td> <td></td> <td></td> <td>1</td> <td>1</td> <td>0</td> <td>0</td> <td>R-</td> </tr> <tr> <td></td> <td></td> <td></td> <td></td> <td colspan="4">0 (~ F)</td> <td>R-00 (~ 15)</td> </tr> <tr> <td></td> <td></td> <td></td> <td></td> <td colspan="4">*2</td> <td>Compteur</td> </tr> <tr> <td></td> <td></td> <td></td> <td></td> <td colspan="4">0 (~ F)</td> <td>R-00 (~ 15)</td> </tr> <tr> <td></td> <td></td> <td></td> <td></td> <td colspan="4">0 0 0 0</td> <td>Pas de changement (Seul le compteur de bande est annulé.)</td> </tr> </tbody> </table> <p>*1: "1" indique un comptage ascendant et "0" un comptage descendant respectivement dans les données de contrôle du compteur de bande. *2: N'importe quoi.</p>	Au niveau PD0 = "L"				Au niveau PD0 = "H"				Affichage	D3	D2	D1	D0	D3	D2	D1	D0	0	0	0	*1	0 (~ F)				-00 (~ 15)	0	0	1	*1	0 (~ F)				00 (~ 15)	0	1	0	*1	0 (~ F)				R-00 (~ 15)					0	0	1	0	End					1	0	0	0	R					1	0	1	0	R End					1	1	0	0	R-					0 (~ F)				R-00 (~ 15)					*2				Compteur					0 (~ F)				R-00 (~ 15)					0 0 0 0				Pas de changement (Seul le compteur de bande est annulé.)																																																																										
Au niveau PD0 = "L"				Au niveau PD0 = "H"				Affichage																																																																																																																																																																																									
D3	D2	D1		D0	D3	D2	D1		D0																																																																																																																																																																																								
0	0	0		*1	0 (~ F)				-00 (~ 15)																																																																																																																																																																																								
0	0	1		*1	0 (~ F)				00 (~ 15)																																																																																																																																																																																								
0	1	0		*1	0 (~ F)				R-00 (~ 15)																																																																																																																																																																																								
				0	0	1	0	End																																																																																																																																																																																									
				1	0	0	0	R																																																																																																																																																																																									
				1	0	1	0	R End																																																																																																																																																																																									
				1	1	0	0	R-																																																																																																																																																																																									
				0 (~ F)				R-00 (~ 15)																																																																																																																																																																																									
				*2				Compteur																																																																																																																																																																																									
				0 (~ F)				R-00 (~ 15)																																																																																																																																																																																									
				0 0 0 0				Pas de changement (Seul le compteur de bande est annulé.)																																																																																																																																																																																									
7	PD1	a	<ul style="list-style-type: none"> <li>Sortie de donnée de contrôle de segment.</li> </ul> Relation entre données de sortie et affichage.																																																																																																																																																																																														
8	PD2	b																																																																																																																																																																																															
9	PD3	g																																																																																																																																																																																															
10	PE0	f																																																																																																																																																																																															
11	PE1	c																																																																																																																																																																																															
12	PE2	e																																																																																																																																																																																															
13	PE3	d	<table border="1"> <thead> <tr> <th rowspan="2">Affichage</th> <th colspan="7">Segment</th> <th rowspan="2">Affichage</th> <th colspan="7">Segment</th> </tr> <tr> <th>a</th> <th>b</th> <th>c</th> <th>d</th> <th>e</th> <th>f</th> <th>g</th> <th>a</th> <th>b</th> <th>c</th> <th>d</th> <th>e</th> <th>f</th> <th>g</th> </tr> </thead> <tbody> <tr> <td>1</td> <td>0</td> <td>1</td> <td>1</td> <td>0</td> <td>0</td> <td>0</td> <td>0</td> <td>R</td> <td>1</td> <td>1</td> <td>0</td> <td>1</td> <td>1</td> <td>1</td> <td>1</td> </tr> <tr> <td>2</td> <td>1</td> <td>1</td> <td>0</td> <td>1</td> <td>1</td> <td>0</td> <td>1</td> <td>E</td> <td>1</td> <td>0</td> <td>0</td> <td>1</td> <td>1</td> <td>1</td> <td>1</td> </tr> <tr> <td>3</td> <td>1</td> <td>1</td> <td>1</td> <td>1</td> <td>0</td> <td>0</td> <td>1</td> <td>n</td> <td>0</td> <td>0</td> <td>1</td> <td>0</td> <td>1</td> <td>0</td> <td>1</td> </tr> <tr> <td>4</td> <td>0</td> <td>1</td> <td>1</td> <td>0</td> <td>0</td> <td>1</td> <td>1</td> <td>d</td> <td>0</td> <td>1</td> <td>1</td> <td>1</td> <td>1</td> <td>0</td> <td>1</td> </tr> <tr> <td>5</td> <td>1</td> <td>0</td> <td>1</td> <td>1</td> <td>0</td> <td>1</td> <td>1</td> <td>-</td> <td>0</td> <td>0</td> <td>0</td> <td>0</td> <td>0</td> <td>0</td> <td>1</td> </tr> <tr> <td>6</td> <td>1</td> <td>0</td> <td>1</td> <td>1</td> <td>1</td> <td>1</td> <td>1</td> <td>r</td> <td>0</td> <td>0</td> <td>0</td> <td>0</td> <td>1</td> <td>1</td> <td>1</td> </tr> <tr> <td>7</td> <td>1</td> <td>1</td> <td>1</td> <td>0</td> <td>0</td> <td>1</td> <td>0</td> <td>R</td> <td>1</td> <td>1</td> <td>1</td> <td>0</td> <td>1</td> <td>1</td> <td>1</td> </tr> <tr> <td>8</td> <td>1</td> <td>1</td> <td>1</td> <td>1</td> <td>1</td> <td>1</td> <td>1</td> <td>E</td> <td>1</td> <td>0</td> <td>0</td> <td>1</td> <td>1</td> <td>1</td> <td>0</td> </tr> <tr> <td>9</td> <td>1</td> <td>1</td> <td>1</td> <td>1</td> <td>0</td> <td>1</td> <td>1</td> <td>P</td> <td>1</td> <td>1</td> <td>0</td> <td>0</td> <td>1</td> <td>1</td> <td>1</td> </tr> <tr> <td>0</td> <td>1</td> <td>1</td> <td>1</td> <td>1</td> <td>1</td> <td>1</td> <td>0</td> <td></td> <td></td> <td></td> <td></td> <td></td> <td></td> <td></td> <td></td> </tr> </tbody> </table>	Affichage	Segment							Affichage	Segment							a	b	c	d	e	f	g	a	b	c	d	e	f	g	1	0	1	1	0	0	0	0	R	1	1	0	1	1	1	1	2	1	1	0	1	1	0	1	E	1	0	0	1	1	1	1	3	1	1	1	1	0	0	1	n	0	0	1	0	1	0	1	4	0	1	1	0	0	1	1	d	0	1	1	1	1	0	1	5	1	0	1	1	0	1	1	-	0	0	0	0	0	0	1	6	1	0	1	1	1	1	1	r	0	0	0	0	1	1	1	7	1	1	1	0	0	1	0	R	1	1	1	0	1	1	1	8	1	1	1	1	1	1	1	E	1	0	0	1	1	1	0	9	1	1	1	1	0	1	1	P	1	1	0	0	1	1	1	0	1	1	1	1	1	1	0								
Affichage	Segment							Affichage	Segment																																																																																																																																																																																								
	a	b	c	d	e	f	g		a	b	c	d	e	f	g																																																																																																																																																																																		
1	0	1	1	0	0	0	0	R	1	1	0	1	1	1	1																																																																																																																																																																																		
2	1	1	0	1	1	0	1	E	1	0	0	1	1	1	1																																																																																																																																																																																		
3	1	1	1	1	0	0	1	n	0	0	1	0	1	0	1																																																																																																																																																																																		
4	0	1	1	0	0	1	1	d	0	1	1	1	1	0	1																																																																																																																																																																																		
5	1	0	1	1	0	1	1	-	0	0	0	0	0	0	1																																																																																																																																																																																		
6	1	0	1	1	1	1	1	r	0	0	0	0	1	1	1																																																																																																																																																																																		
7	1	1	1	0	0	1	0	R	1	1	1	0	1	1	1																																																																																																																																																																																		
8	1	1	1	1	1	1	1	E	1	0	0	1	1	1	0																																																																																																																																																																																		
9	1	1	1	1	0	1	1	P	1	1	0	0	1	1	1																																																																																																																																																																																		
0	1	1	1	1	1	1	0																																																																																																																																																																																										
14	Vss	Vss	+B (10V)																																																																																																																																																																																														
15	TEST	TEST																																																																																																																																																																																															
16	PF0	4G	<ul style="list-style-type: none"> <li>Sortie de donnée d'exploration de grille.</li> </ul> Relation entre sortie de balayage et digits d'affichage.																																																																																																																																																																																														
17	PF1	3G																																																																																																																																																																																															
18	PF2	2G																																																																																																																																																																																															
19	PF3	1G		<table border="1"> <thead> <tr> <th>Grille</th> <th colspan="4">Digit d'affichage</th> </tr> <tr> <th></th> <th>4ème digit</th> <th>3ème digit</th> <th>2ème digit</th> <th>1er digit</th> </tr> </thead> <tbody> <tr> <td>1G</td> <td>0</td> <td>0</td> <td>0</td> <td>1</td> </tr> <tr> <td>2G</td> <td>0</td> <td>0</td> <td>1</td> <td>0</td> </tr> <tr> <td>3G</td> <td>0</td> <td>1</td> <td>0</td> <td>0</td> </tr> <tr> <td>4G</td> <td>1</td> <td>0</td> <td>0</td> <td>0</td> </tr> </tbody> </table>	Grille	Digit d'affichage					4ème digit	3ème digit	2ème digit	1er digit	1G	0	0	0	1	2G	0	0	1	0	3G	0	1	0	0	4G	1	0	0	0																																																																																																																																																															
Grille	Digit d'affichage																																																																																																																																																																																																
	4ème digit	3ème digit	2ème digit	1er digit																																																																																																																																																																																													
1G	0	0	0	1																																																																																																																																																																																													
2G	0	0	1	0																																																																																																																																																																																													
3G	0	1	0	0																																																																																																																																																																																													
4G	1	0	0	0																																																																																																																																																																																													
20	PG0	NC	<ul style="list-style-type: none"> <li>Bornes inutilisées</li> </ul>																																																																																																																																																																																														
21	PA0	NC																																																																																																																																																																																															
22	PA1	NC																																																																																																																																																																																															

N° de borne	Nom de borne	Désignation de fonction	Fonctions
23	PA2	C.RESET	<ul style="list-style-type: none"> <li>● Entrée de touche de remise à zéro du compteur de bande.</li> <li>● Affichage "0 0 0" à entrée de niveau "L".</li> </ul>
24	PA3	NC	<ul style="list-style-type: none"> <li>● Borne inutilisée</li> </ul>
25	INT	REEL PULSE	<ul style="list-style-type: none"> <li>● Entrée d'impulsion de bloc bobine pour détection d'extrémité de la bande.</li> <li>● Le compteur effectue le comptage ascendant et descendant par cette impulsion. (Comptage ±1 à entrée de 8 impulsions)</li> <li>● Le compteur est ramené à zéro quand l'extrémité de la bande est détectée pendant le rebobinage.</li> </ul>
26	RES	RESET	<ul style="list-style-type: none"> <li>● Entrée d'impulsion de remise à zéro</li> </ul>
27	VGG	VGG	<ul style="list-style-type: none"> <li>● GND (masse)</li> </ul>
28	CLO	CLO	<ul style="list-style-type: none"> <li>● Oscillation d'horloge interne</li> </ul>

2. Table de fonction des bornes μPD553C-229N (micro-ordinateur)

N° de borne	Nom de borne	Désignation de fonction	Fonctions																																																																																
1	CL1	CLOCK	<ul style="list-style-type: none"> <li>● LC pour oscillation d'horloge est à fixation externe.</li> </ul>																																																																																
2 3 4 5	PC0 PC1 PC2 PC3	K0 K1 K2 K3	<ul style="list-style-type: none"> <li>● Bornes d'entrée pour détection de position de mécanisme par interrupteur rotatif monté sur le mécanisme.</li> <li>● Positions de 11 modes disponibles par "H" et "L" de chaque porte. Ces modes sont codés pour contrôler le mécanisme.</li> </ul> <table border="1" style="margin-left: 40px;"> <thead> <tr> <th rowspan="2"></th> <th colspan="4">Marche arrière</th> <th colspan="4">Marche avant</th> </tr> <tr> <th>PLAY</th> <th>↔</th> <th>PAUSE &amp; SEARCH</th> <th>↔</th> <th>STOP</th> <th>↔</th> <th>F.F &amp; REW</th> <th>↔</th> <th>PAUSE &amp; SEARCH</th> <th>↔</th> <th>PLAY</th> </tr> </thead> <tbody> <tr> <td>K0</td> <td>0</td> <td>0</td> <td>0</td> <td>1</td> <td>1</td> <td>1</td> <td>1</td> <td>1</td> <td>0</td> <td>0</td> <td>1</td> </tr> <tr> <td>K1</td> <td>1</td> <td>1</td> <td>0</td> <td>0</td> <td>0</td> <td>0</td> <td>1</td> <td>1</td> <td>1</td> <td>0</td> <td>0</td> </tr> <tr> <td>K2</td> <td>0</td> <td>1</td> <td>1</td> <td>1</td> <td>0</td> <td>0</td> <td>0</td> <td>1</td> <td>1</td> <td>1</td> <td>1</td> </tr> <tr> <td>K3</td> <td>1</td> <td>1</td> <td>1</td> <td>1</td> <td>1</td> <td>0</td> <td>0</td> <td>0</td> <td>0</td> <td>0</td> <td>0</td> </tr> <tr> <td>Code</td> <td>A</td> <td>E</td> <td>C</td> <td>D</td> <td>9</td> <td>1</td> <td>3</td> <td>7</td> <td>6</td> <td>4</td> <td>5</td> </tr> </tbody> </table>		Marche arrière				Marche avant				PLAY	↔	PAUSE & SEARCH	↔	STOP	↔	F.F & REW	↔	PAUSE & SEARCH	↔	PLAY	K0	0	0	0	1	1	1	1	1	0	0	1	K1	1	1	0	0	0	0	1	1	1	0	0	K2	0	1	1	1	0	0	0	1	1	1	1	K3	1	1	1	1	1	0	0	0	0	0	0	Code	A	E	C	D	9	1	3	7	6	4	5
	Marche arrière				Marche avant																																																																														
	PLAY	↔	PAUSE & SEARCH	↔	STOP	↔	F.F & REW	↔	PAUSE & SEARCH	↔	PLAY																																																																								
K0	0	0	0	1	1	1	1	1	0	0	1																																																																								
K1	1	1	0	0	0	0	1	1	1	0	0																																																																								
K2	0	1	1	1	0	0	0	1	1	1	1																																																																								
K3	1	1	1	1	1	0	0	0	0	0	0																																																																								
Code	A	E	C	D	9	1	3	7	6	4	5																																																																								
6	INT	REEL PULSE	<ul style="list-style-type: none"> <li>● Borne d'entrée d'impulsion de bobine pour détection d'extrémité de bande.</li> <li>● Le traitement en fin de bande est effectué quand l'entrée d'impulsion est perdue pendant 3 secondes au cours de la lecture ou de l'enregistrement/lecture, et pendant 1 seconde pendant l'avance rapide/rebobinage ou l'avance rapide/rebobinage à recherche.</li> <li>● Le rebobinage à dépassement à la sélection de musique et de répétition multiple est accompli par comptage d'impulsion à la borne d'entrée.</li> </ul>																																																																																
7	RES	RESET	<ul style="list-style-type: none"> <li>● Borne de remise à zéro micro-ordinateur. Le micro-ordinateur est rétabli quand le niveau "H" est entré pendant au moins 4 cycles machine (10μsec).</li> </ul>																																																																																
8	PD0	LEADER	<ul style="list-style-type: none"> <li>● Borne d'entrée pour détection de l'amorce de bande.</li> <li>● La détection de l'amorce commence respectivement 10 secondes et 1 seconde après que la bande a commencé à défiler en mode de lecture et d'enregistrement/lecture et au cours de la recherche.</li> <li>● Pour bandes sans amorce, la bande défile jusqu'à son extrémité. A cet endroit, le niveau "H" est sorti à la borne PH2 et l'inversion prend place par détection du sélecteur de mode.</li> <li>● L'inversion prend place quand le niveau "L" est entré à la borne d'entrée.</li> </ul>																																																																																
9	PD1	MUSIC	<ul style="list-style-type: none"> <li>● Borne d'entrée pour détection du signal musical aux niveaux "H", "L".</li> </ul>																																																																																
10	PD2	MULT1	<ul style="list-style-type: none"> <li>● Borne d'entrée de touche de répétition multiple.</li> <li>● L'entrée de touche est assumée à l'entrée de niveau "L".</li> </ul>																																																																																
11	PD3	PROT/HEAD	<ul style="list-style-type: none"> <li>● La détection du sélecteur de protection d'enregistrement est accomplie lorsque le niveau "H" est sorti de la borne PE3; la détection de la direction de la tête est accomplie quand le niveau "L" est sorti à la même borne.</li> <li>● Quand le niveau "H" est entré à cette borne d'entrée, la protection d'enregistrement est réalisable et la direction de la tête devient la marche avant.</li> </ul>																																																																																

N° de borne	Nom de borne	Désignation de fonction	Fonctions																																																																																																		
12	PE0	LINE MUTE	<ul style="list-style-type: none"> <li>Borne de sortie de contrôle de sourdine d'ampli de ligne.</li> </ul>																																																																																																		
13	PE1	REC MUTE	<ul style="list-style-type: none"> <li>Borne de sortie de contrôle de sourdine d'ampli d'enregistrement.</li> </ul>																																																																																																		
14	PE2	BIAS	<ul style="list-style-type: none"> <li>Borne de sortie de contrôle de circuit d'oscillation de polarisation.</li> </ul>																																																																																																		
15	PE3	MODE	<ul style="list-style-type: none"> <li>Borne de sortie d'horloge pour contrôle de micro-ordinateur de compteur.</li> <li>Le signal de commutation de détection de protection/tête de la borne PD3 est sorti.</li> </ul>																																																																																																		
16 17 18 19	PF0 PF1 PF2 PF3	DATA0 DATA1 DATA2 DATA3	<ul style="list-style-type: none"> <li>Bornes de sortie de données pour contrôle de micro-ordinateur de compteur.</li> <li>Données de 8 bits sorties de PF0 ~ PF3 en synchronisation avec l'horloge de la borne PE3.</li> <li>Quand la borne PED3 est au niveau "L", le compteur compte de façon ascendante quand la borne PF0 est au niveau "H" et de façon descendante quand la même borne est au niveau "L".</li> <li>Quand la tête est sur le côté de marche avant, "End" est affiché à l'arrêt à l'extrémité de la bande après comptage de façon ascendante.</li> <li>"000" est affiché à l'arrêt à l'extrémité de la bande après comptage de façon descendante. Ce mode est inversé quand la tête se trouve sur le côté de marche arrière.</li> <li>Affichage par données de 8 bits.</li> </ul> <table border="1" style="margin-left: 20px;"> <thead> <tr> <th colspan="8">MODE</th> <th rowspan="2">Sortie de micro-ordinateur</th> </tr> <tr> <th colspan="4">0</th> <th colspan="4">1</th> </tr> <tr> <th>D3</th> <th>D2</th> <th>D1</th> <th>D0</th> <th>D3</th> <th>D2</th> <th>D1</th> <th>D0</th> <th>Affichage</th> </tr> </thead> <tbody> <tr> <td>0</td> <td>0</td> <td>0</td> <td>0/1</td> <td>0</td> <td>0</td> <td>0</td> <td>0</td> <td>000 15</td> </tr> <tr> <td>0</td> <td>0</td> <td>0</td> <td>0/1</td> <td>1</td> <td>1</td> <td>1</td> <td>1</td> <td>000 15</td> </tr> <tr> <td>0</td> <td>1</td> <td>0</td> <td>0/1</td> <td>0</td> <td>0</td> <td>0</td> <td>0</td> <td>R-000 R-15</td> </tr> <tr> <td>0</td> <td>1</td> <td>1</td> <td>0/1</td> <td>0</td> <td>0</td> <td>1</td> <td>0</td> <td>End</td> </tr> <tr> <td>1</td> <td>0</td> <td>0</td> <td>0/1</td> <td>0</td> <td>0</td> <td>0</td> <td>0</td> <td>P-000 P-15</td> </tr> <tr> <td>1</td> <td>0</td> <td>1</td> <td>0/1</td> <td colspan="4">(N'importe quoi)</td> <td>Affichage de compteur</td> </tr> <tr> <td>1</td> <td>1</td> <td>0</td> <td>0/1</td> <td>0</td> <td>0</td> <td>0</td> <td>0</td> <td>R-000 R-15</td> </tr> <tr> <td>1</td> <td>1</td> <td>1</td> <td>0</td> <td colspan="4">(N'importe quoi)</td> <td>000</td> </tr> </tbody> </table>	MODE								Sortie de micro-ordinateur	0				1				D3	D2	D1	D0	D3	D2	D1	D0	Affichage	0	0	0	0/1	0	0	0	0	000 15	0	0	0	0/1	1	1	1	1	000 15	0	1	0	0/1	0	0	0	0	R-000 R-15	0	1	1	0/1	0	0	1	0	End	1	0	0	0/1	0	0	0	0	P-000 P-15	1	0	1	0/1	(N'importe quoi)				Affichage de compteur	1	1	0	0/1	0	0	0	0	R-000 R-15	1	1	1	0	(N'importe quoi)				000
MODE								Sortie de micro-ordinateur																																																																																													
0				1																																																																																																	
D3	D2	D1	D0	D3	D2	D1	D0	Affichage																																																																																													
0	0	0	0/1	0	0	0	0	000 15																																																																																													
0	0	0	0/1	1	1	1	1	000 15																																																																																													
0	1	0	0/1	0	0	0	0	R-000 R-15																																																																																													
0	1	1	0/1	0	0	1	0	End																																																																																													
1	0	0	0/1	0	0	0	0	P-000 P-15																																																																																													
1	0	1	0/1	(N'importe quoi)				Affichage de compteur																																																																																													
1	1	0	0/1	0	0	0	0	R-000 R-15																																																																																													
1	1	1	0	(N'importe quoi)				000																																																																																													
20	TEST	TEST	+B (10V)																																																																																																		
21	VSS	VSS	+B (10V)																																																																																																		
22 23	PG0 PG1	RMF RMR	<ul style="list-style-type: none"> <li>Bornes de sortie pour contrôle de moteur de bobine.</li> <li>Le moteur de bobine tourne dans le sens de l'avance rapide quand PG0 et PG1 sont aux niveaux "H" et "L", respectivement, et dans le sens de rebobinage quand ils sont aux niveaux "L" et "H" respectivement. Le moteur de bobine s'arrête quand PG0 et PG1 sont tous deux au niveau "L".</li> <li>PG0 est utilisé comme borne de sortie pour le sélecteur de mode de détection.</li> </ul>																																																																																																		
24 25	PG2 PG3	AMF AMR	<ul style="list-style-type: none"> <li>Bornes de sortie pour contrôle de moteur auxiliaire.</li> <li>La position du mécanisme passe de la marche arrière à la marche avant quand PG2 et PG3 sont aux niveaux "H" et "L" respectivement. Elle passe de la marche avant à la marche arrière quand PG2 et PG3 sont aux niveaux "L" et "H" respectivement. Le moteur auxiliaire s'arrête quand PG2 et PG3 sont tous deux au niveau "L".</li> </ul>																																																																																																		

N° de borne	Nom de borne	Désignation de fonction	Fonctions
26	PH0	OUT-PLAY	<ul style="list-style-type: none"> <li>Le niveau "H" est sorti pendant la lecture et l'enregistrement/lecture pour effectuer la commutation de la tension du moteur de bobine.</li> </ul>
27	PH1	TIMER	<ul style="list-style-type: none"> <li>Borne de sortie pour lecture, enregistrement/lecture à minuterie.</li> <li>Le niveau "L" est fourni pendant 4 secondes après que l'interrupteur d'alimentation est placé sur "ON", et le niveau "H" est fourni quand le programme fait une entrée en routine principale après 4 secondes.</li> </ul>
28	PH2	PULSE	<ul style="list-style-type: none"> <li>Quand la bande arrive à son extrémité pendant la lecture, l'enregistrement/lecture ou en mode de recherche, le niveau "H" est fourni après 3 secondes pendant la lecture et l'enregistrement/lecture, et après 1 seconde en mode de recherche.</li> <li>La tête inverse quand la borne PD0 devient au niveau "L" pendant la sortie du niveau "H". Quand la borne PD0 ne devient pas au niveau "L" même si la sortie de cette borne dure 500 msec, le mécanisme est réglé au mode d'arrêt et cette borne assume aussi le niveau "L".</li> </ul>
29	PH3	PLAY.S	<ul style="list-style-type: none"> <li>Borne de sortie pour système de contrôle à une touche. Le niveau "H" est fourni quand cette unité assume l'état de lecture par DRPS, etc, pour commuter la fonction du système à une touche. Le niveau "L" est assumé quand cette unité a été réglée au mode d'arrêt.</li> </ul>
30	PI0	PAUSE IND.	<ul style="list-style-type: none"> <li>Borne de sortie de contrôle de témoin de pause. Le niveau "H" est fourni en mode de Pause.</li> <li>Des impulsions de 500msec et 50msec sont périodiquement fournies durant le mode de sourdine automatique à l'enregistrement et en mode d'attente à l'enregistrement, respectivement.</li> <li>Le niveau "H" est fourni quand la touche de Pause est actionnée en mode de recherche.</li> </ul>
31	PI1	PLAY IND.	<ul style="list-style-type: none"> <li>Borne de sortie de contrôle de témoin de lecture. Le niveau "H" est fourni quand le moteur de bobine est arrêté.</li> <li>Des impulsions sont fournies en synchronisation avec les impulsions de bobine en mode de lecture.</li> <li>Des impulsions de 125msec sont fournies en synchronisation si le sélecteur de minuterie est placé sur ON pendant 4 secondes après avoir placé l'interrupteur d'alimentation sur ON.</li> <li>Des impulsions de 50msec sont périodiquement fournies en mode de recherche.</li> </ul>
32	PI2	REC IND.	<ul style="list-style-type: none"> <li>Témoin d'enregistrement et borne de sortie de commutation de tête d'enregistrement/lecture.</li> <li>Le niveau "H" est fourni pendant le contrôle d'enregistrement (monitoring) et l'enregistrement.</li> <li>Le niveau "H" est fourni si le sélecteur de minuterie est placé sur REC/PLAY pendant 4 secondes après avoir placé l'interrupteur d'alimentation sur ON. Le niveau "L" est fourni quand le taquet de prévention d'enregistrement de la cassette est brisé quand la détection de la commande de protection d'enregistrement est réalisée.</li> <li>Cette borne assume le niveau "L" quand la tête est inversée vers le côté de marche avant au cours de l'enregistrement sur le côté de marche arrière.</li> </ul>
33	PA0	MUTE	<ul style="list-style-type: none"> <li>Bornes d'entrée de touche de contrôle.</li> <li>Entrée de touche assumée au niveau "L".</li> <li>La borne PA0 est utilisée conjointement pour l'entrée des touches de sourdine (mute) et DRPS (mémorisation).</li> <li>Le traitement d'entrée de la touche de recherche et lecture est assumé quand les bornes PB2 et PB3 ont toutes deux assumé le niveau "L".</li> </ul>
34	PA1	REC	
35	PA2	PAUSE	
36	PA3	STOP	
37	PB0	REW	
38	PB1	F.F	
39	PB2	R-PLAY	
40	PB3	F-PLAY	
41	VGG	VGG	GND (masse)
42	CLO	CLOCK	<ul style="list-style-type: none"> <li>LC pour oscillation d'horloge attachée extérieurement.</li> </ul>

DESCRIPTION OF NEW MECHANISM

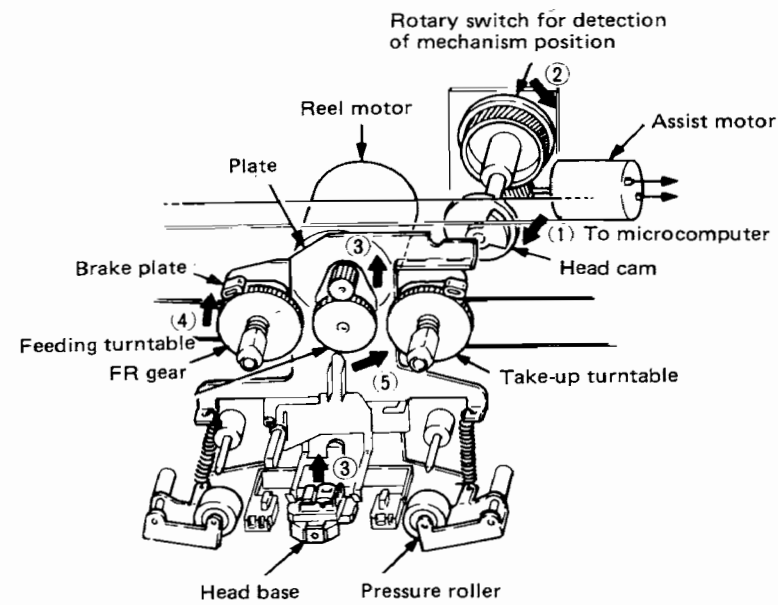
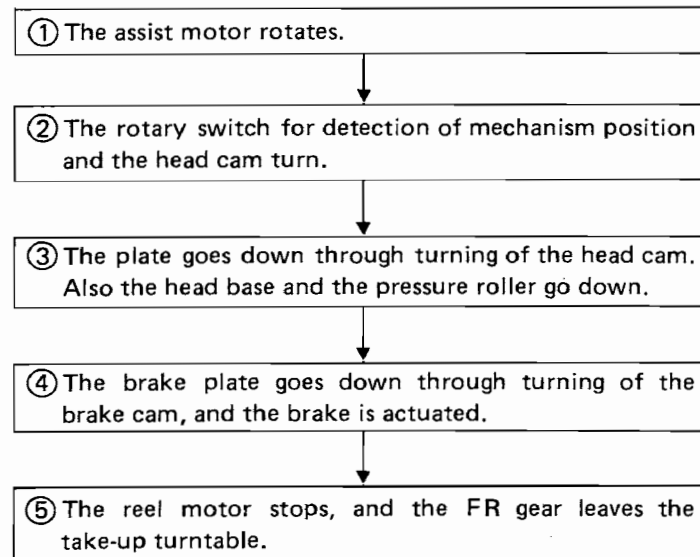


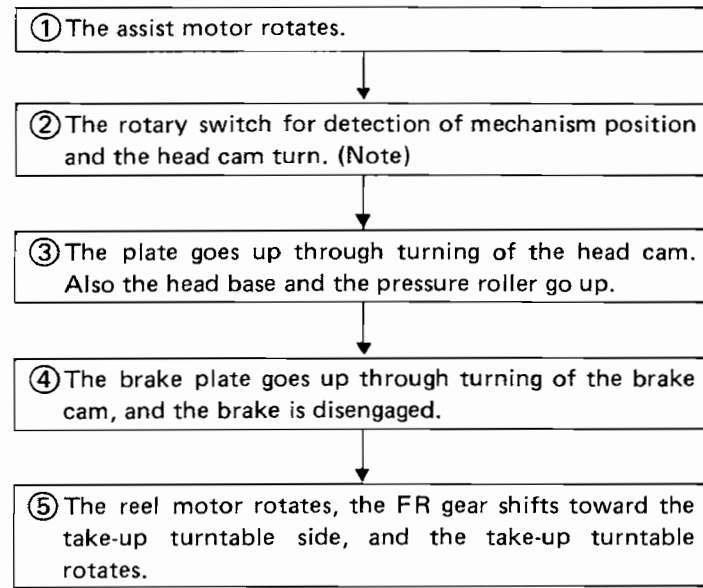
Fig. 16

2. STOP MODE

(When changing from PLAYBACK state to STOP state)

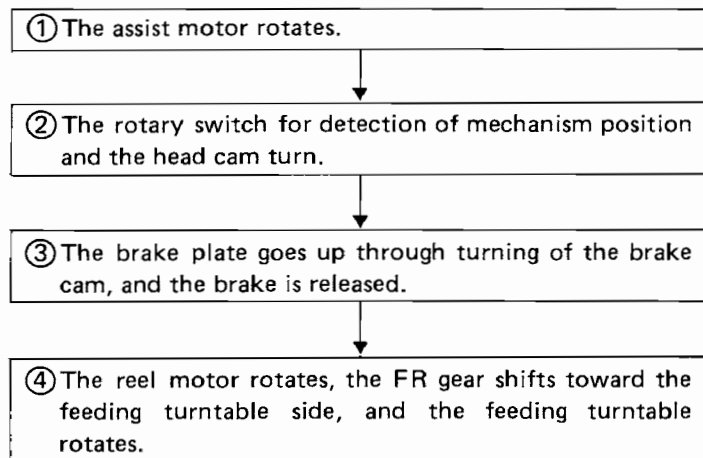


1. PLAYBACK MODE

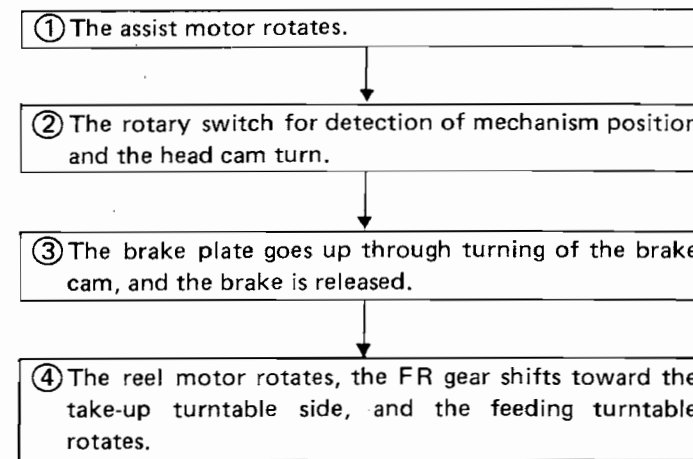


Note: The mode changes according to the direction and angle of rotation of the head cam.

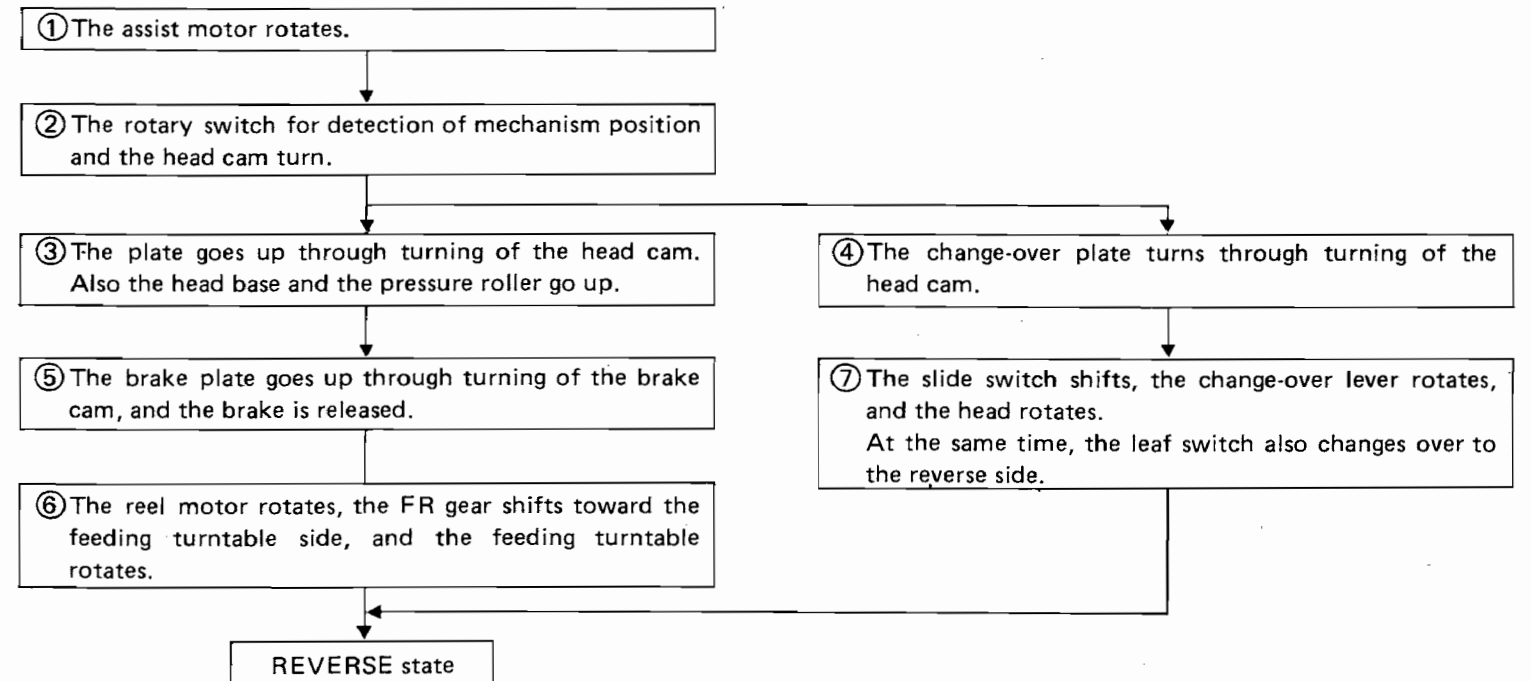
3. REWIND MODE



4. FAST FORWARD MODE

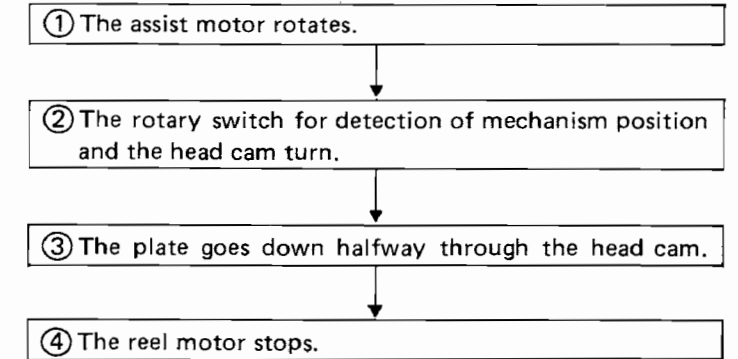


6. REVERSE MODE

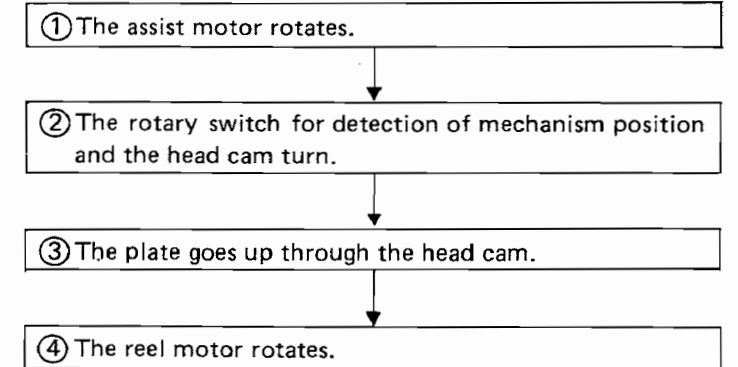


5. PAUSE MODE

(When changing from PLAYBACK state to PAUSE state)



(When changing from PAUSE state to PLAYBACK state)



BESCHREIBUNG DES NEUEN MECHANISMUS

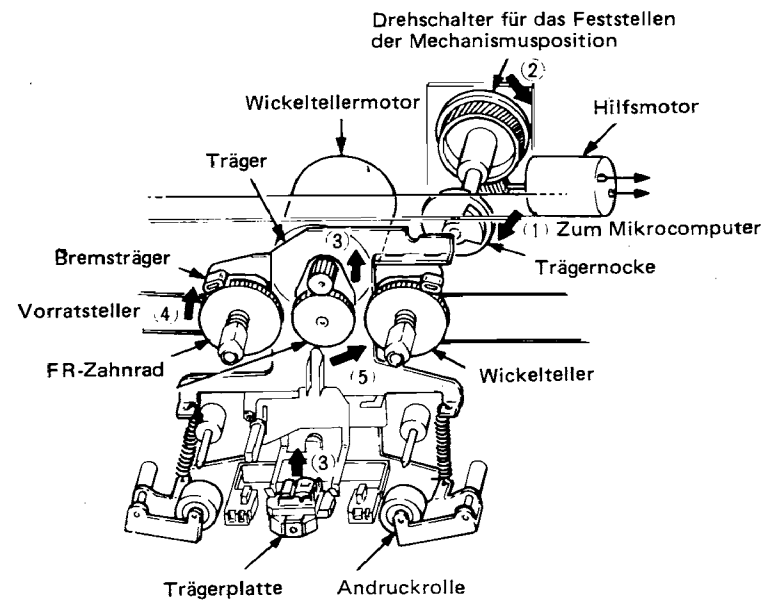
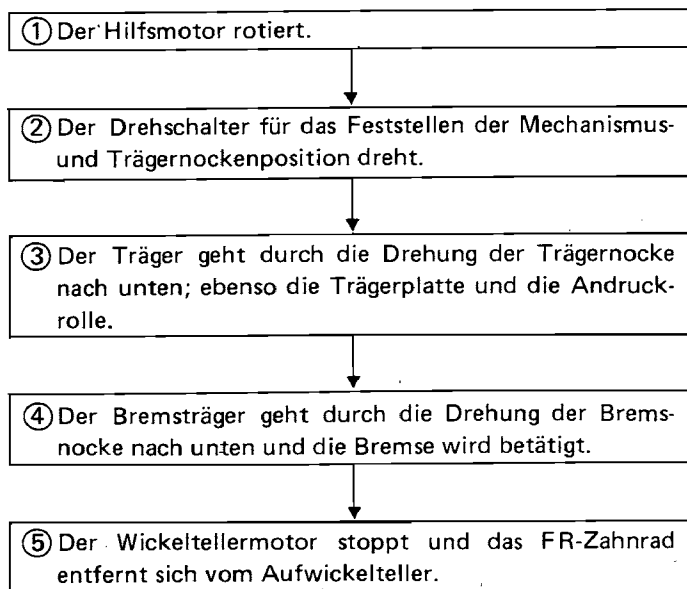


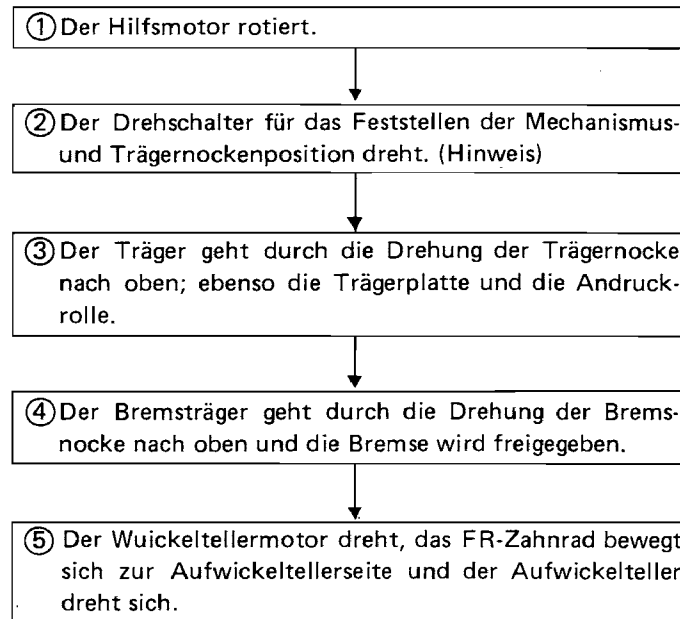
Abb. 16

2. STOPPFUNKTION

(Änderung von Wiedergabe- auf Stoppfunktion)

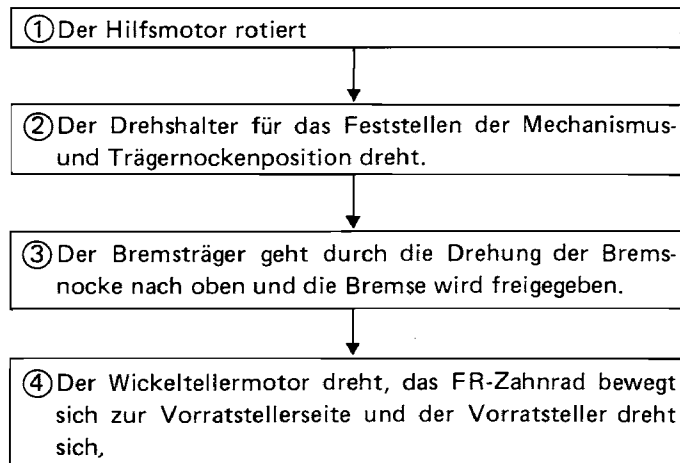


1. WIEDERGABEFUNKTION

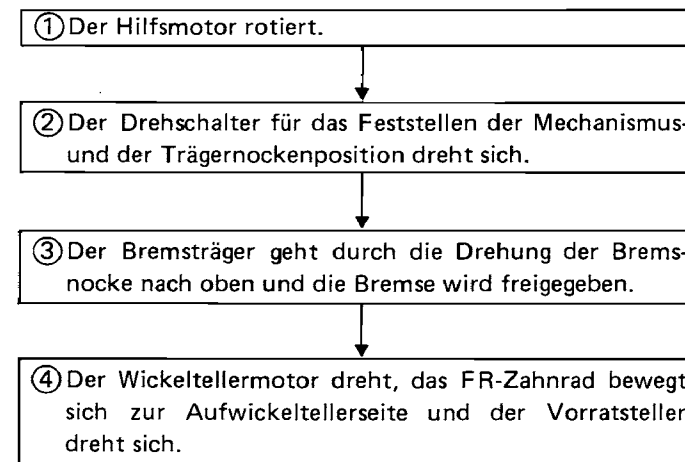


Hinweis: Die Betriebsart ändert sich entsprechend dem Drehsinn und Drehwinkel der Trägernocke.

3. RÜCKLAUFBETRIEB

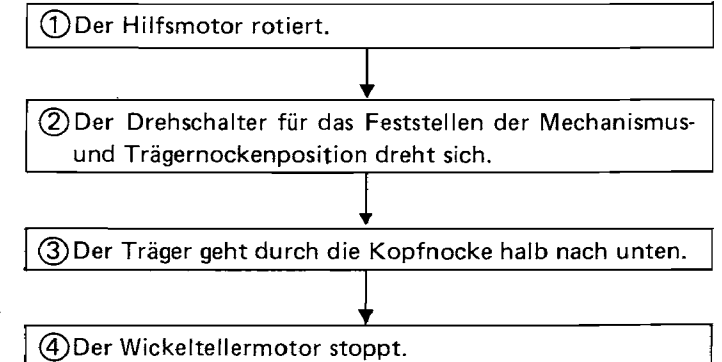


4. SCHNELLVORLAUF-FUNKTION

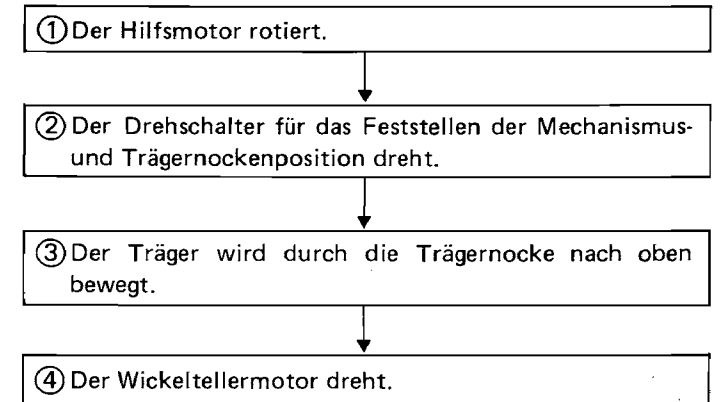


5. PAUSEFUNKTION

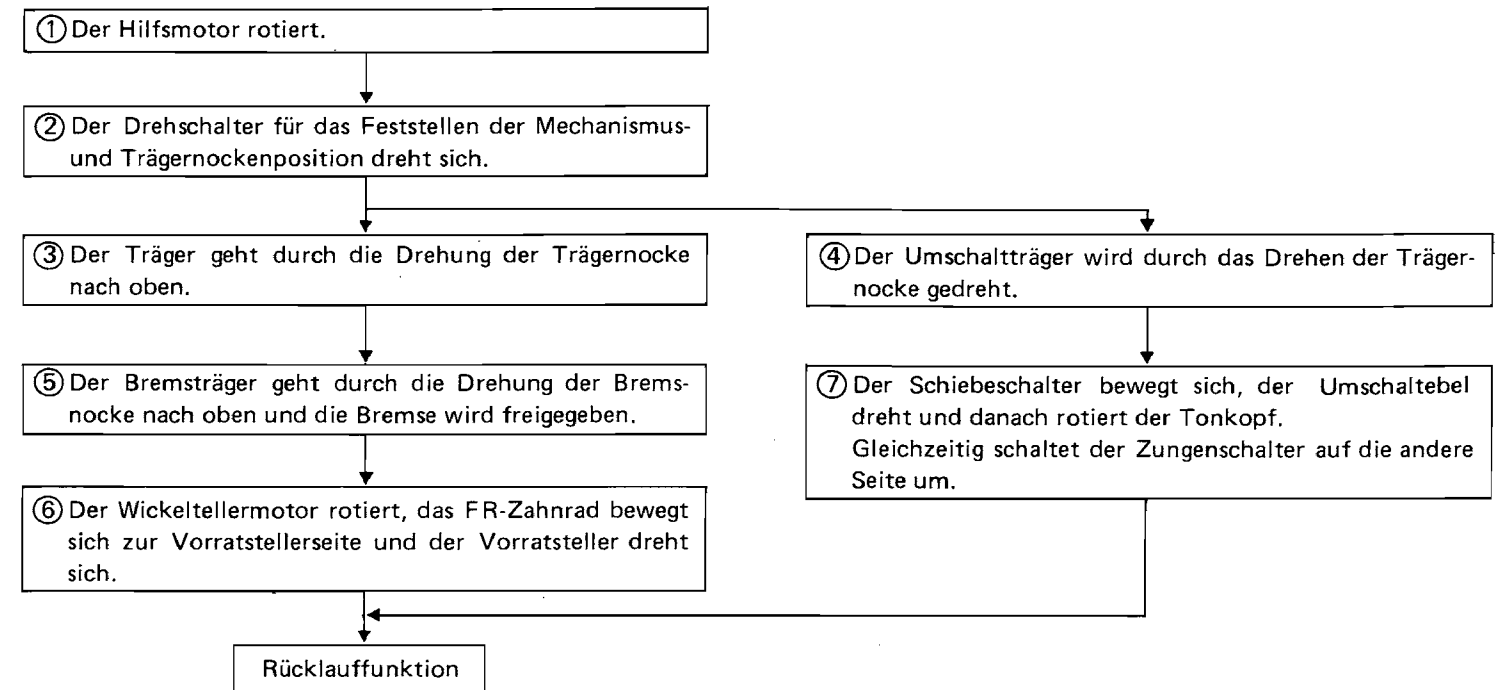
(Umschalten von Wiedergabe- auf Pausefunktion)



(Beim Umschalten von Pause- auf Wiedergabefunktion)



6. RÜCKLAUF-FUNKTION



## DESCRIPTION DES NOUVEAUX MÉCANISMES

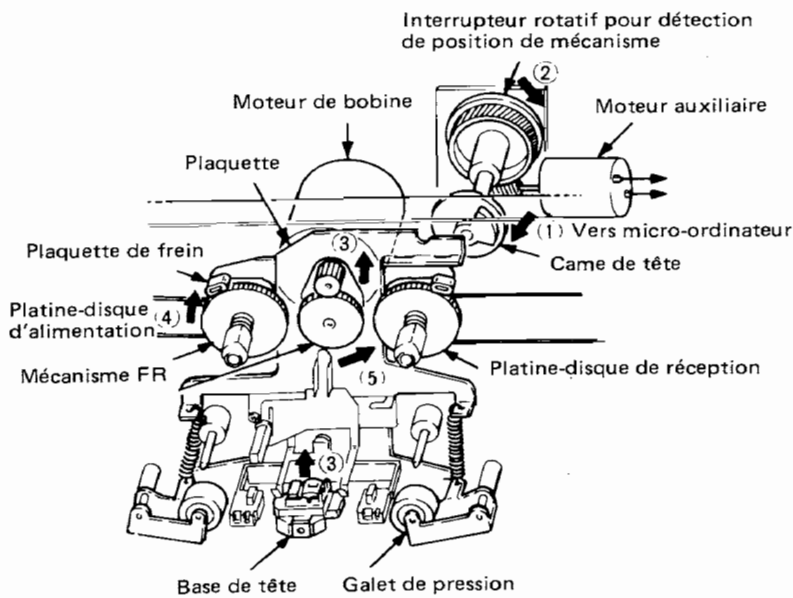


Fig. 16

## 2. MODE D'ARRÊT

(Lors du passage du mode de lecture au mode d'arrêt)

① Le moteur auxiliaire tourne.

② L'interrupteur rotatif pour la détection de la position de mécanisme et la came de tête tournent.

③ La plaquette descend par la rotation de la came de tête. De plus, la base de tête et le galet de pression descendent.

④ La plaquette de frein descend par la rotation de la came de tête et le frein est actualisé.

⑤ Le moteur de bobine s'arrête et le mécanisme FR relâche la platine réceptrice.

## 1. MODE DE LECTURE

① Le moteur auxiliaire tourne.

② L'interrupteur rotatif pour détection de position de mécanisme et la came de tête tournent. (Note)

③ La plaquette remonte par la rotation de la came de tête. De plus, la base de tête et le galet de pression remontent.

④ La plaquette de frein remonte par la rotation de la came de tête et le frein est libéré.

⑤ Le moteur de bobine tourne, le mécanisme FM se déplace vers le côté de platine réceptrice et la platine d'alimentation tourne.

Note: Le mode change en fonction de la direction et de l'angle de rotation de la came de tête.

## 3. MODE DE REBOBINAGE

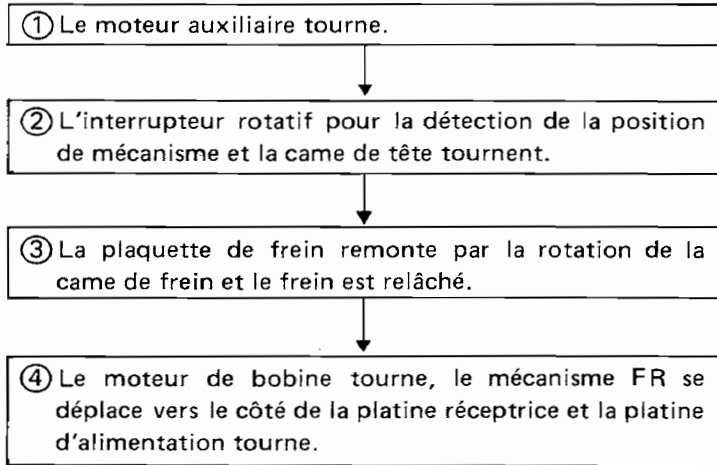
① Le moteur auxiliaire tourne.

② L'interrupteur rotatif pour la détection de la position de mécanisme et la came de tête tournent.

③ La plaquette de frein remonte par la rotation de la came de frein et le frein est relâché.

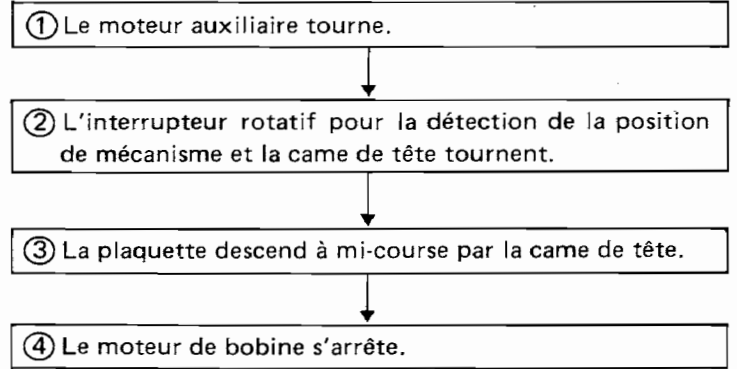
④ Le moteur de bobine tourne, le mécanisme FR se déplace vers le côté de platine d'alimentation et celle-ci tourne.

**4. MODE D'AVANCE RAPIDE**

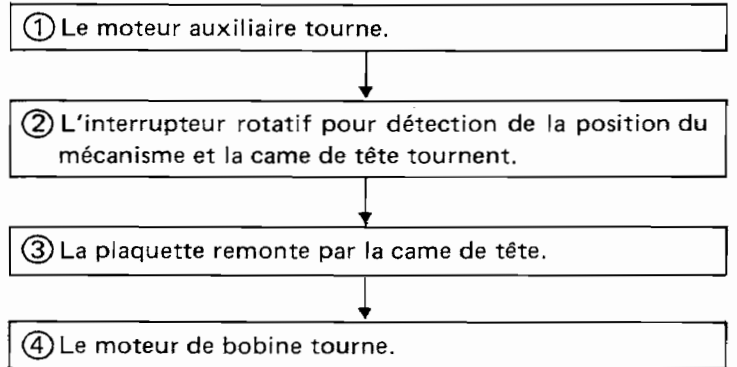


**5. MODE DE PAUSE**

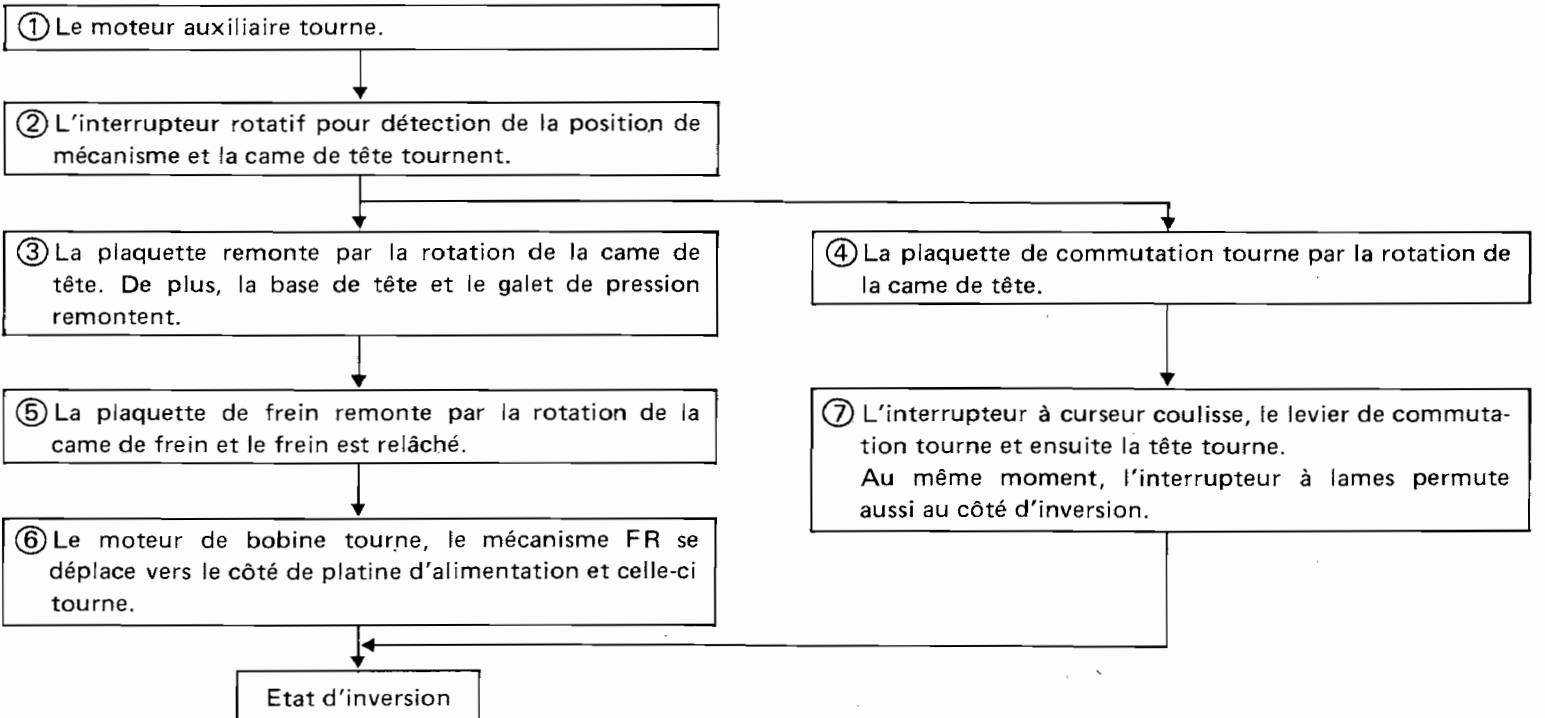
(Lors du passage du mode de lecture au mode de pause)



(Lors du passage du mode de pause au mode de lecture)



**6. MODE D'INVERSION**





DESCRIPTION OF NEW CIRCUIT · BESCHREIBUNG DES NEUEN STROMKREISES · DESCRIPTION DES NOUVEAUX CIRCUITS

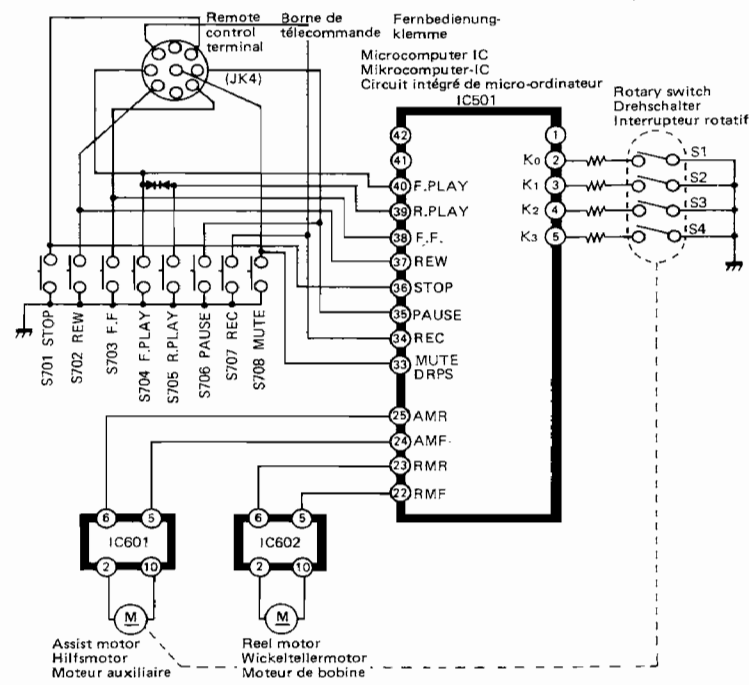


Fig. 17 Abb. 17

When the control button is pressed, the assist motor rotates on receiving a signal from the microcomputer IC (IC501). When the assist motor rotates, the rotary switches (S1 ~ 4), which are interlocked with it, also rotate. The mechanism modes (PLAY, STOP, etc.) have been determined through

combination of S1 ~ 4. The assist motor stops when the rotary switch for detection of mechanism position rotated up to the position of the mode of the control button which was pressed. (See table below.)

Wenn die Steuertaste betätigt wird, dreht der Hilfsmotor nach Empfang eines Signals vom Mikrocomputer-IC (IC501). Wenn der Hilfsmotor rotiert, drehen sich gleichzeitig die damit verriegelten Drehschalter (S1 ~ 4). Die Mechanismus-Betriebsarten (Wiedergabe, Stopp usw.) werden

durch die Schalterkombinationen S1 ~ 4 bestimmt. Der Hilfsmotor stoppt, wenn der Drehschalter für das Feststellen der Mechanismusposition bis zu der Betriebsart der betätigten Steuertaste gedreht ist. (Siehe untenstehende Tabelle.)

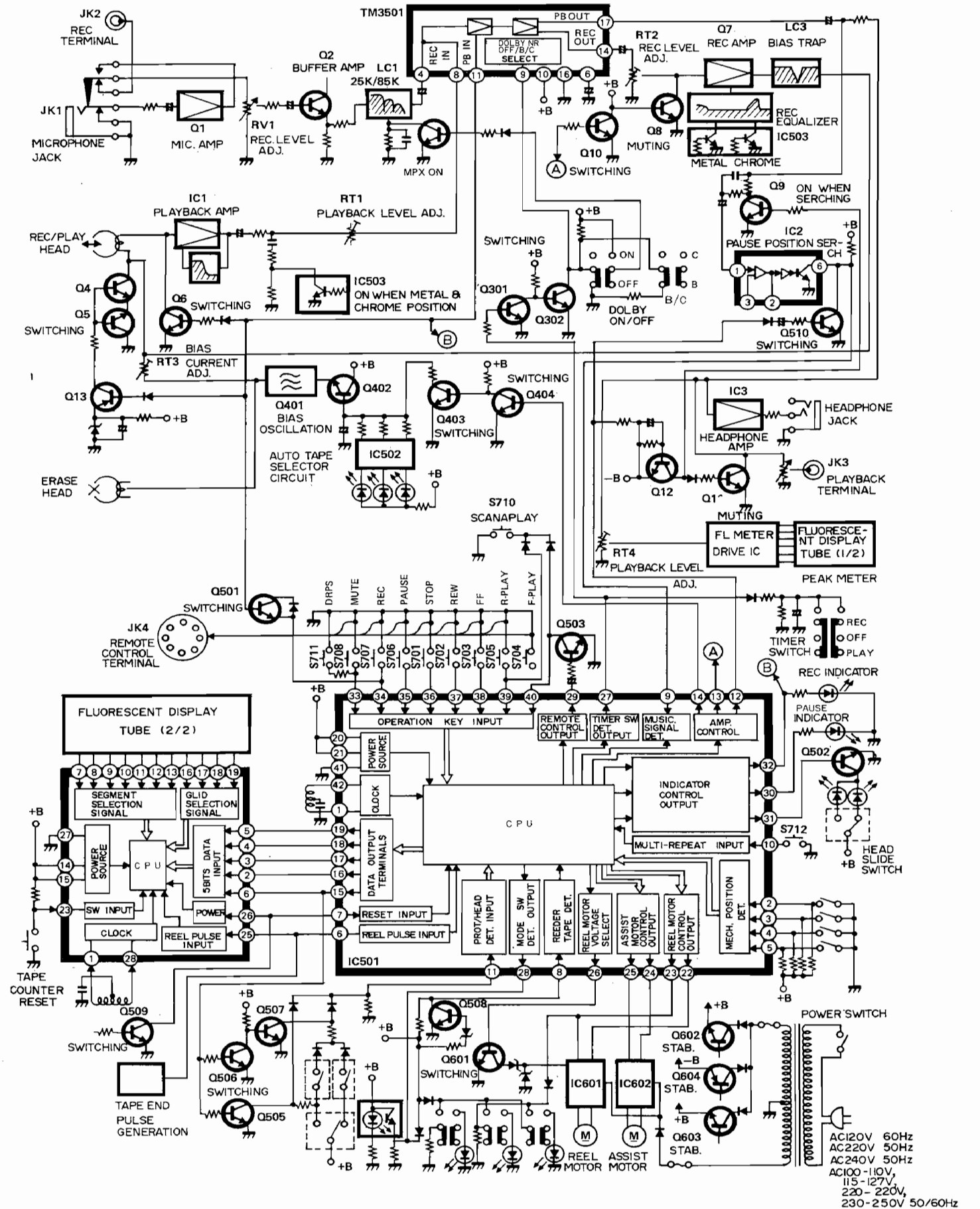
Quand le bouton de contrôle est actionné, le moteur auxiliaire tourne à la réception d'un signal du circuit intégré de micro-ordinateur (IC501). Quand le moteur auxiliaire tourne, les interrupteurs rotatifs (S1 ~ 4) qui lui sont couplés, tournent également. Les modes de mécanisme

(lecture, arrêt, etc.) ont été déterminés par combinaison de S1 ~ 4. Le moteur auxiliaire s'arrête quand l'interrupteur rotatif pour détection de la position de mécanisme tourne jusqu'à la position du mode du bouton de contrôle qui a été actionné. (Voir tableau ci-dessous.)

Mechanism mode Mechanismus- Betriebsart Mode de méca- nisme	Reverse Rücklauf Inversion			FWD							
	PLAY	↔	PAUSE SEARCH	↔	STOP	↔	FF & REW	↔	PAUSE & SEARCH	↔	PLAY
S1	ON	ON	ON	-	-	-	-	-	ON	ON	-
S2	-	-	ON	ON	ON	ON	-	-	-	ON	ON
S3	ON	-	-	-	ON	ON	ON	-	-	-	-
S4	-	-	-	-	-	ON	ON	ON	ON	ON	ON

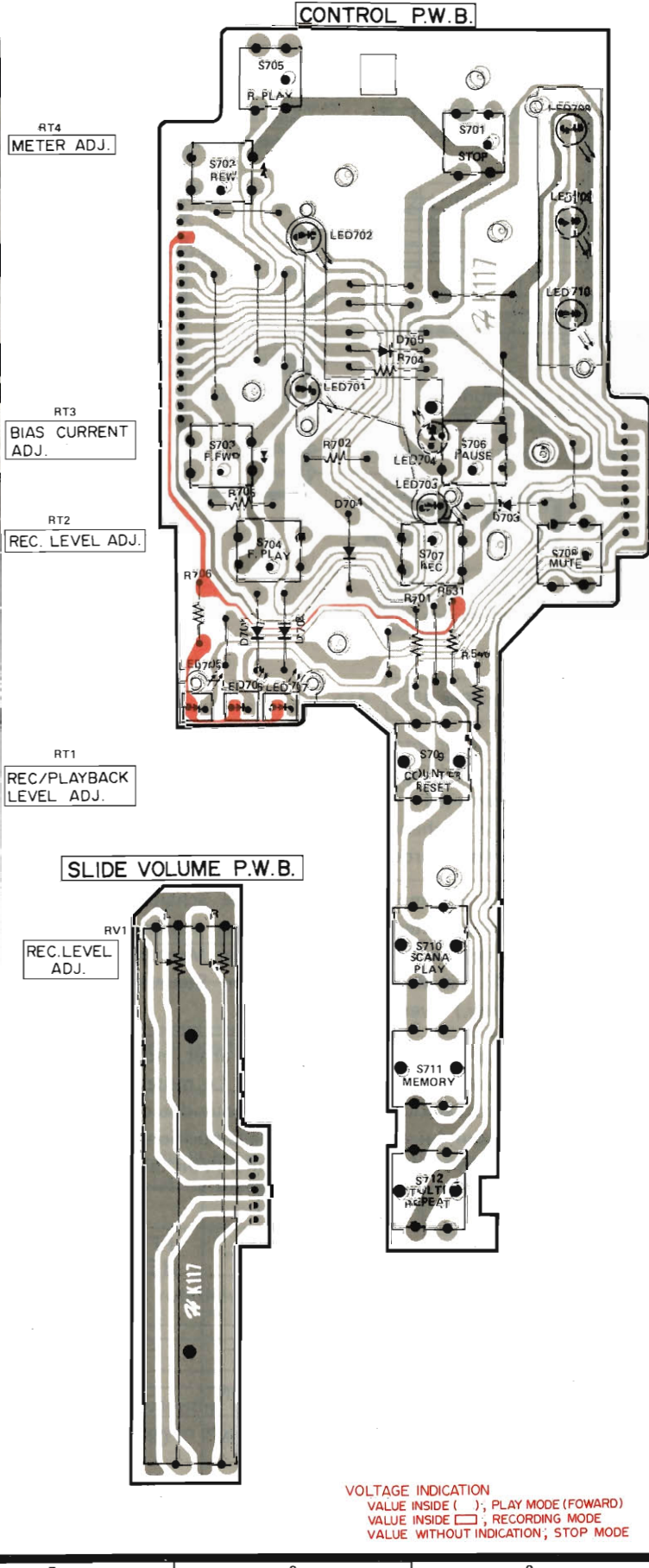
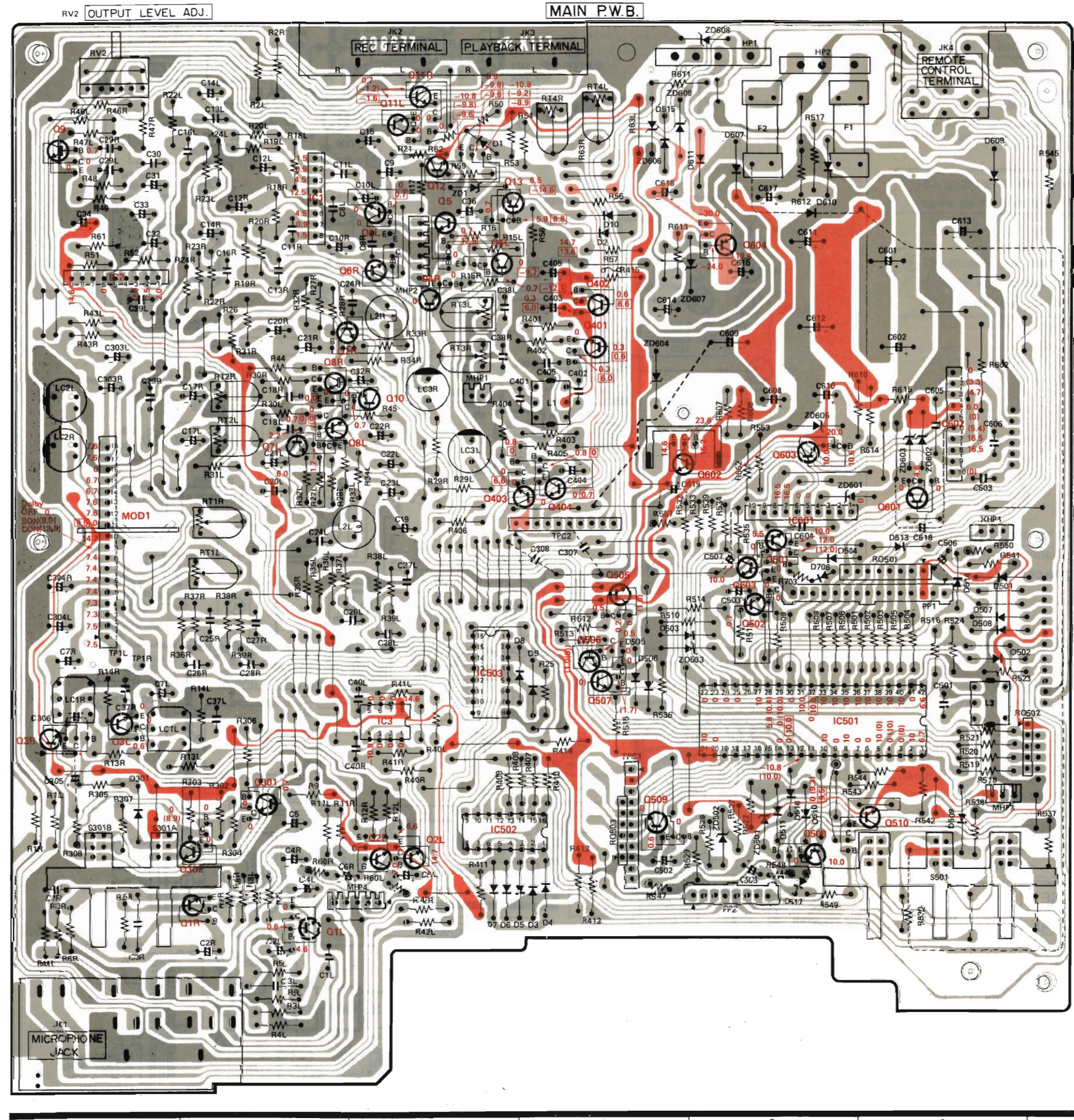
Reverse rotation ← Normal rotation →

BLOCK DIAGRAM · BLOCKSCHEMA · SCHÉMA



PRINTED WIRING BOARD · PRINTPLATTEN · PLAN DE BASE

[ ■ : + B, ■ : - B, ■ : Earth, ■ : Other]



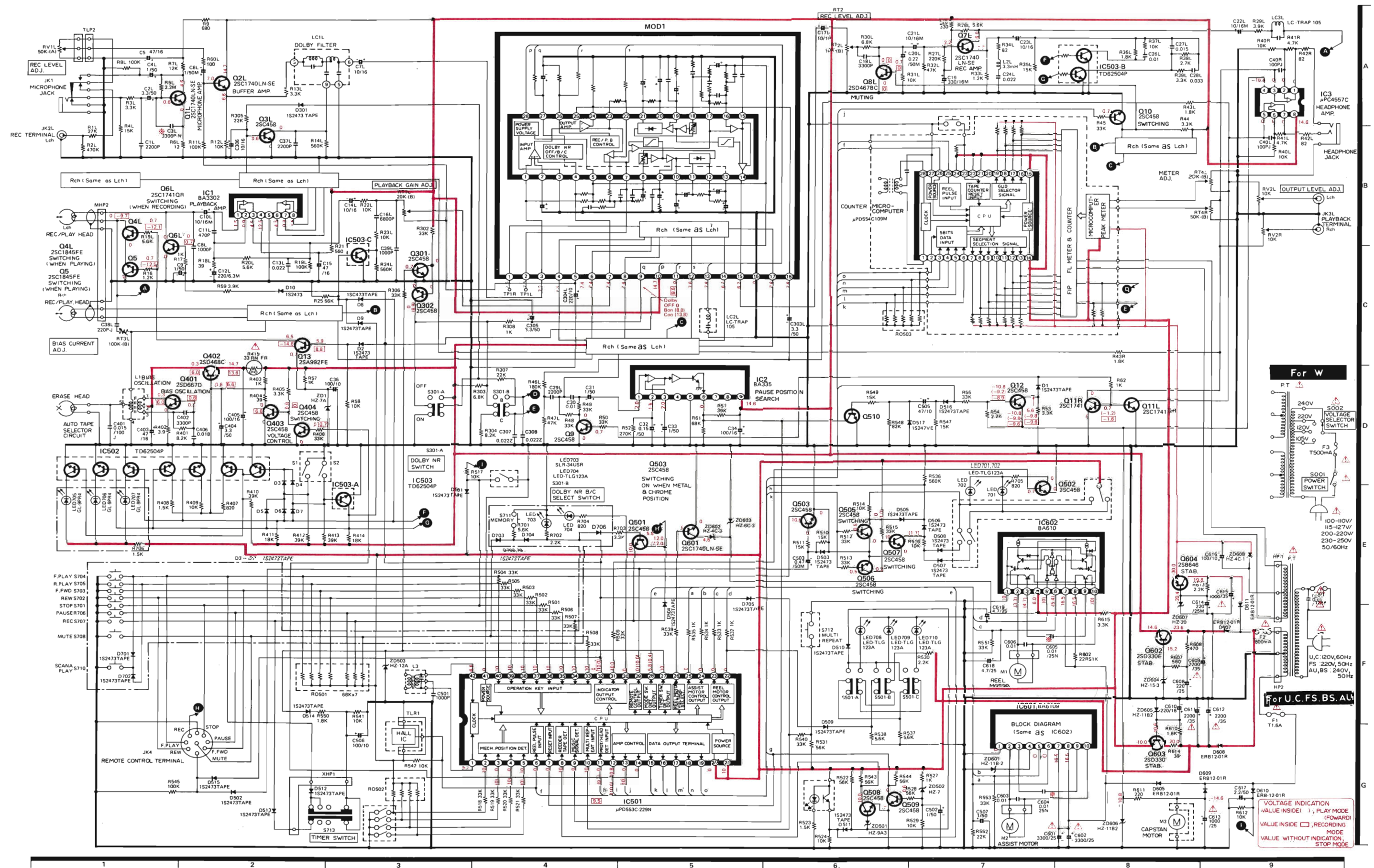
	µPD553
	TD62504P
	BA6109
	BA335
	BA3302
	µPC4557C
	2SA992FE 2SC458LG 2SC1740LN-SE 2SC1741QR 2SC1845FE
	2SB646C 2SD468C 2SD667A
	2SD330AL
	1S2473, HZ-4C-1 HZ-4C3, HZ-6C3 HZ-7A, HZ-9A-3 HZ-9C, HZ-11B2 HZ-12A, HZ-15-3 HZ-20
	K A
	K A
	K A
	ERB12-01R
	K A

VOLTAGE INDICATION  
 VALUE INSIDE ( ); PLAY MODE (FORWARD)  
 VALUE INSIDE ( ); RECORDING MODE  
 VALUE WITHOUT INDICATION; STOP MODE

CIRCUIT DIAGRAM · SCHALTPLAN · PLAN DE CIRCUIT

CAUTION Use the electrolytic capacitors with explosion-proof valve when the diameter of them is more than 10 mmφ.

- \* : Axial lead cylindrical ceramic capacitor.
- \* : Zylindrischer Keramik Kondensator mit axialer Zuleitung.
- \* : Condensateur céramique cylindrique à conducteur axial.

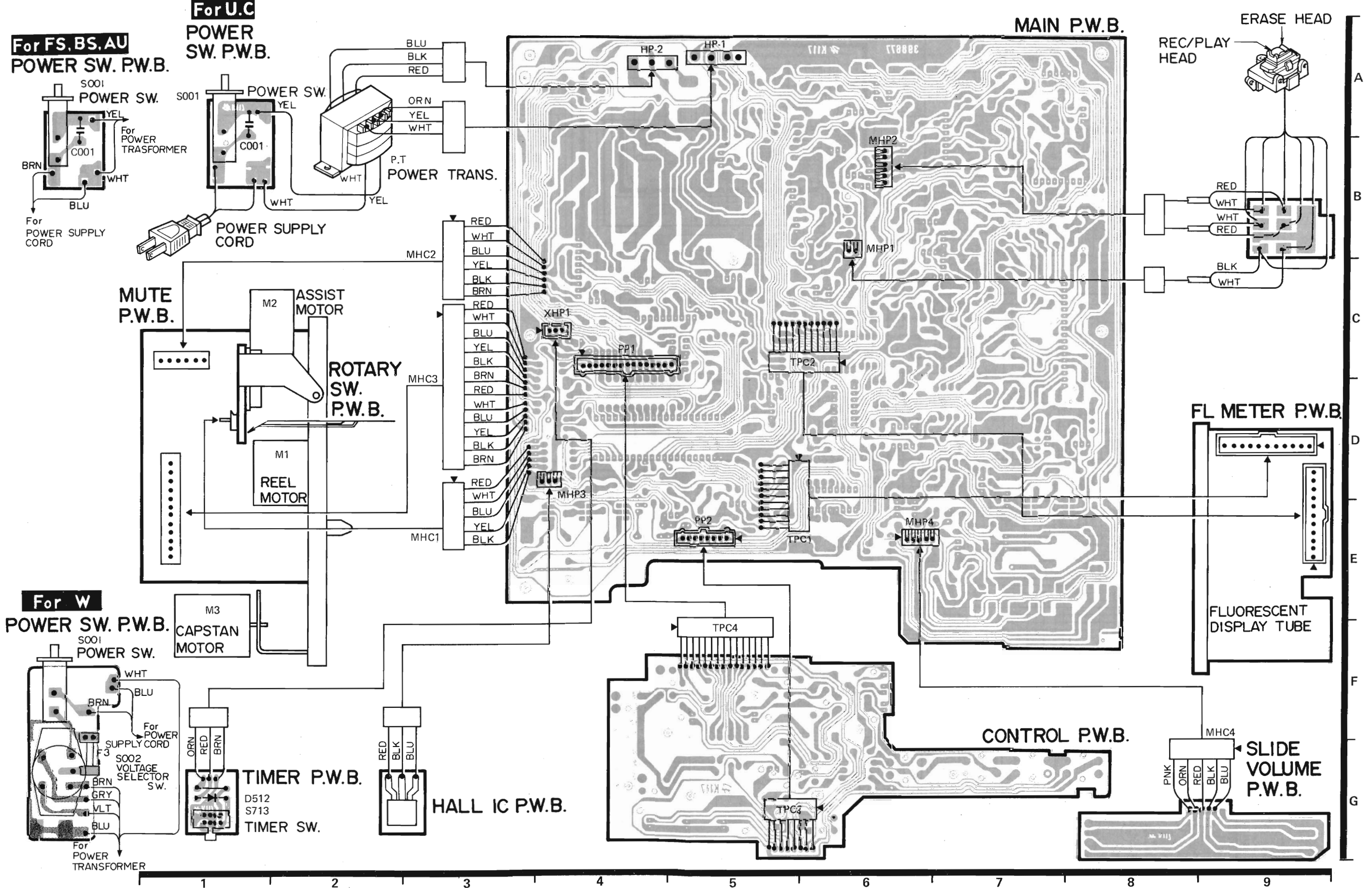


For W

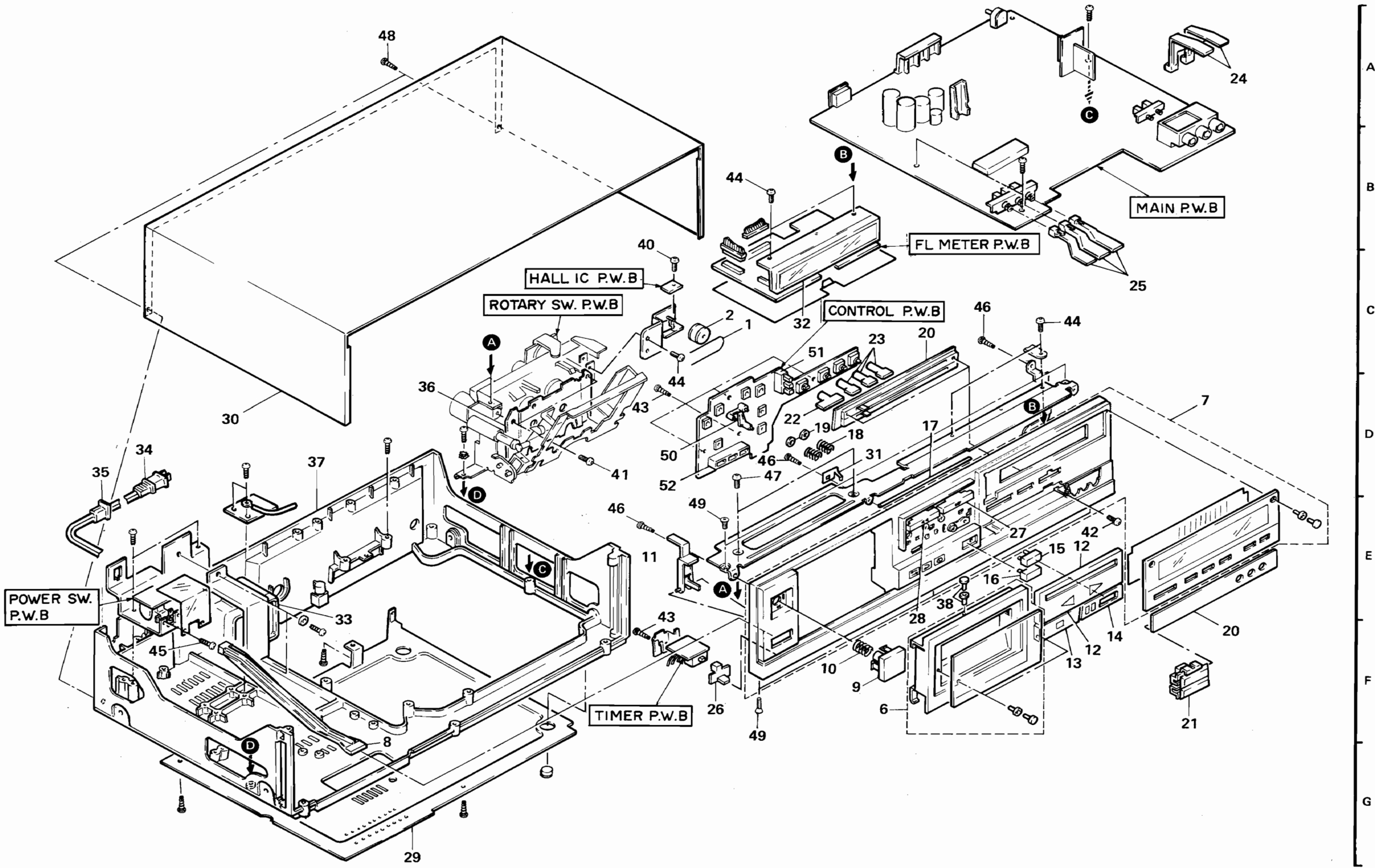
For U.C.F.S.B.S.A.L

VOLTAGE INDICATION  
 VALUE INSIDE ( ) , PLAY MODE  
 VALUE INSIDE □ , RECORDING  
 MODE  
 VALUE WITHOUT INDICATION , STOP MODE

WIRING DIAGRAM · VERDRÄHTUNGSSCHEMA · SCHÉMA DE CÂBLAGE

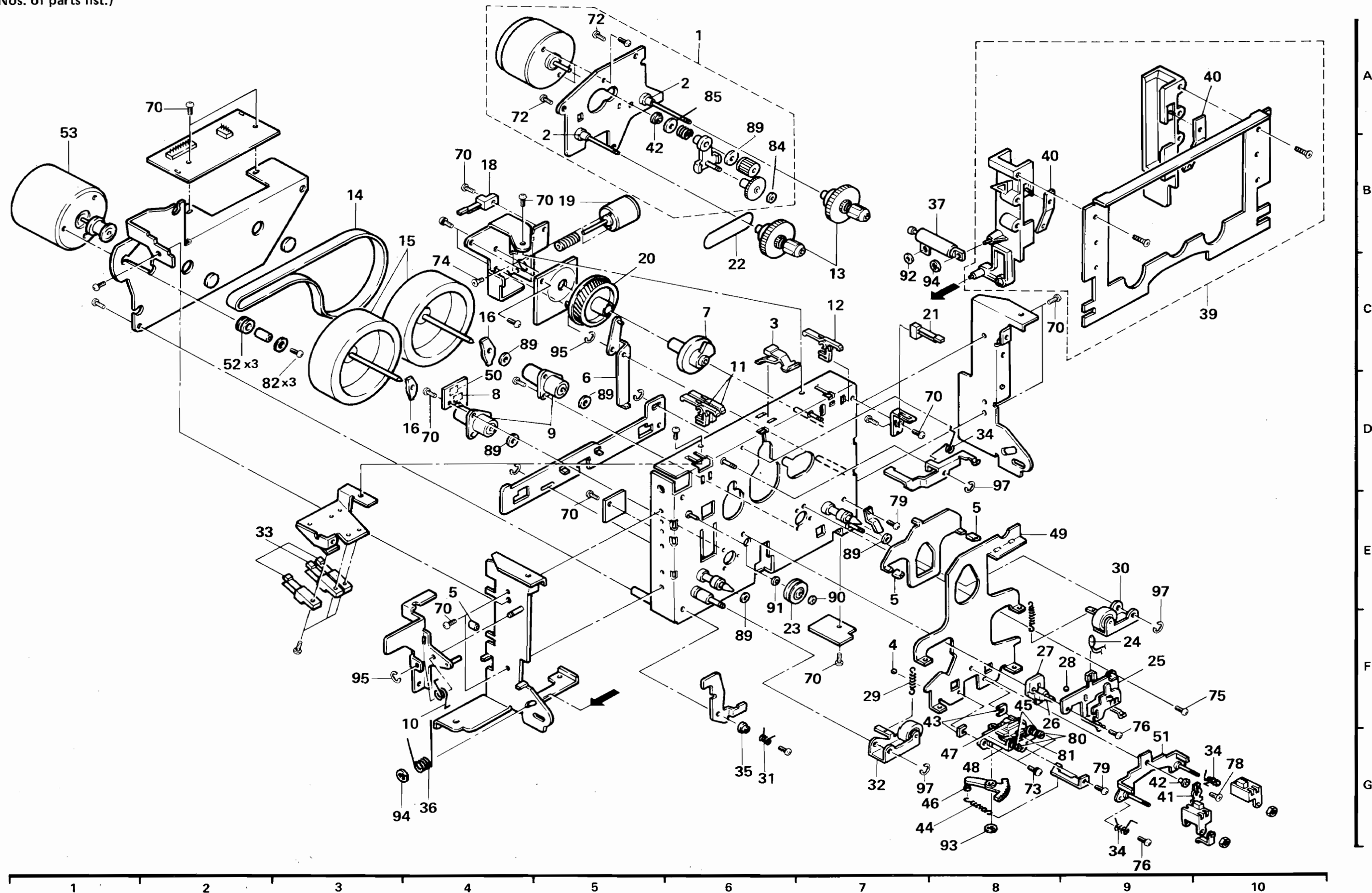


EXPLODED VIEW (Cabinet) · EXPLOSIONSANSICHT (Chassis) · VUE EXPLOSEE (Coffret)  
(Nos. are reference Nos. of parts list)



1 2 3 4 5 6 7 8 9 10

EXPLODED VIEW (Cassette chassis: PAD-121R) · EXPLOSIONSANSICHT (Chassetten-Tonbandgerät: PAD-121R) · VUE EXPLOSEE (Magnétphone: PAD-121R)  
(Nos. are reference Nos. of parts list.)



## REPLACEMENT PARTS LIST · ERSATZTEILLISTE · TABLEAU DES PIÈCES

## CASSETTE CHASSIS

ITEM No.	PART No.	DESCRIPTION	ITEM No.	PART No.	DESCRIPTION
1	4022951	Motor holder ass'y	44	3364981	Spring for take up coil
2	4586281	Spindle bush	45	3364992	Compress coil spring
3	4450741	Cassette holder spring	46	3958471	Rewind gear
4	4586031	Ball	47	2555831	RECORD / PLAYBACK & ERASE head
5	4690501	Brake rubber	48	4022921	Head plate ass'y
6	4022811	Select lever ass'y	49	4022931	Head base ass'y
7	3958331	Cam	50	2317811	Photo transistor (TPS-605)
8	4996931	LED TLR121	51	4022941	Change plate ass'y
9	4022851	C stand ass'y	52	4690541	Cushion
10	3364911	Twist coil spring	53	4088731	Motor ass'y
11	3958341	REC lever	70	4996631	2.5φ × 5 screw
12	3958351	Rec lever (R)	71	4996842	2.6φ × 6 screw
13	4022821	Reel base ass'y	72	4996841	2.6φ × 5 screw
14	4690511	Belt	73	4996681	2φ × 4 screw
15	3357191	Flywheel	74	4996691	2φ × 3 screw
16	4450491	Thrust spring	75	4996715	3φ × 4 screw
17	4996871	Lever switch	76	4996632	2.5φ × 8 screw
18	4996881	Leaf switch	77	4996751	2φ × 3.2 screw
19	2523691	Motor	78	4996793	2φ × 6 flat screw
20	4022831	Rotary gear ass'y	80	4996801	Screw
21	4996891	Leaf switch	81	4996814	2φ × 3 screw
22	4690527	Belt	82	4996761	Screw
23	3347161	Pulley			
24	2767713	Lamp			
25	4450551	Head plate holder	84	4996647	Washer
26	3958411	Half guide	85	4996643	Washer
27	3958421	Guide base		4996831	Washer
28	4586033	Ball		4996649	Washer
29	3364932	Coil spring		4996642	Washer
30	4022861	Pinch arm ass'y (F)	89	4996646	Washer
31	3364941	Coil spring	90	4996642	Washer
32	4022871	Pinch arm ass'y (R)	91	4996648	Washer
33	4996951	Leaf switch ass'y	92	4996851	Washer
34	3364951	Spring	93	4996648	Washer
35	4586181	Collar	94	4996731	Washer
36	3364961	Coil spring			
37	3958431	Damper unit	95	4996621	2.5φ E ring
38	3364971	Coil spring	96	4996622	3φ E ring
39	4022891	Cassette holder ass'y	97	4996651	2φ E ring
40	4450611	Cassette spring			
41	4450641	Spring			
42	4586241	Collar			
43	4450751	Spacer			
					<b>for ACCESSORIES</b>
				2717893	Patch cord
				2658361	E socket adapter (for W. Germany)

## CABINET CHASSIS

ITEM No.	PART No.	DESCRIPTION	ITEM No.	PART No.	DESCRIPTION
1	4690421	Counter belt	31	4447661	Earth spring
2	3346461	Counter pulley ass'y	32	2597524	FL meter ass'y
3	4931986	Polyslider washer	△ 33	2248102	Power transformer (for U.S.A. and Canada)
4	4418005	Polyslider washer	△	2248105	Power transformer (for West Germany)
5	4931982	Polyslider washer	△	2248103	Power transformer
6	4022041	Cassette door ass'y			(for Sweden & Switzerland)
7	4022091	Front panel ass'y	△	2248104	Power transformer (for U.K. & Australia)
8	3296081	Power button ass'y	△ 34	2718113	Power supply cord (for U.S.A. & Canada)
9	3295663	Eject button ass'y	△	2718091	Power supply cord
10	3362631	Eject spring			(for West Germany, Sweden & Switzerland)
11	3955321	Eject lever	△	2717902	Power supply cord (for U.K.)
12	3296071	Play button ass'y	△	2717951	Power supply cord (for Australia)
13	3296091	Stop button ass'y	△ 35	3946231	Bushing
14	3296101	Pause button ass'y	36	3901517	Chassis ass'y (except West Germany)
15	3295641	REC button ass'y		3901518	Chassis ass'y (for West Germany)
16	3295631	Mute button ass'y	37	4700693	Leg
17	4585201	Pause shaft			
18	3362641	Operation key spring	40	4584581	2.6φ × 4 pan head screw
19	3901781	Washer S	41	0714303	2.6φ × 3 pan head screw
20	3249712	Slide base	42	0711306	2.6φ × 6 pan head screw
21	3295772	Slide knob ass'y	43	8691308	2.6φ × 8 BT screw
22	3295732	Reset button	44	4567411	3φ × 6 DT bind screw
23	3295692	S & P button	45	4567431	3φ × 6 DT bind screw
24	3296161	Dolby button	46	8691408	3φ × 8 BT bind screw
25	3296171	Mode knob	47	8699408	3φ × 8 BT bind screw
26	3296062	Timer knob	48	8691410	3φ × 10 BT bind screw
27	3296151	FF knob	49	4577831	3φ × 10 BT flat head screw
28	3296141	REW knob		8698410	3φ × 10 BT bind screw
29	4434113	Bottom cover		4577832	3φ × 10 BT flat head screw
30	4434101	Upper cover			

REPLACEMENT PARTS LIST · ERSATZTEILLISTE · TABLEAU DES PIÈCES

SYMBOL No.	PART No.	DESCRIPTION			SYMBOL No.	PART No.	DESCRIPTION		
<b>CAPACITORS</b>									
C1 L,R	0209733	Ceramic, discal	2200pF ±10%	50V	C603	0209737	Ceramic, discal	0.01μF ±10%	50V
C2 L,R	0252813	Electrolytic	3.3μF	50V	C604	0240106	Cylindrical ceramic	0.01μF ±30%	25V
C3 L,R	0240103	Cylindrical ceramic	3300pF ±30%	50V	C605	0240106	Cylindrical ceramic	0.01μF ±30%	25V
C4 L,R	0252811	Electrolytic	1μF	50V	C606	0209737	Ceramic, discal	0.01μF ±10%	50V
C5	0252525	Electrolytic	47μF	16V	C608	0252632	Electrolytic	220μF	25V
C6 L,R	0252811	Electrolytic	1μF	50V	△C609	0252742	Electrolytic	2200μF	35V
C7 L,R	0252521	Electrolytic	10μF	16V	C610	0252532	Electrolytic	220μF	16V
C8 L,R	0209731	Ceramic, discal	1000pF ±10%	50V	△C611	0252742	Electrolytic	2200μF	35V
C9	0252811	Electrolytic	1μF	50V	△C612	0252742	Electrolytic	2200μF	35V
C10 L,R	0252521	Electrolytic	10μF	16V	△C613	0252636	Electrolytic	1000μF	25V
C11 L,R	0209723	Ceramic, discal	470μF ±10%	50V	C614	0252632	Electrolytic	220μF	25V
C12 L,R	0252232	Electrolytic	220μF	6.3V	△C615	0252731	Electrolytic	1000μF	35V
C13 L,R	0275013	Mylar, film	0.022μF ±10%	50V	C616	0252331	Electrolytic	100μF	10V
C14 L,R	0252521	Electrolytic	10μF	16V	C617	0252812	Electrolytic	10μF	25V
C15	0252525	Electrolytic	47μF	16V	C618	0252615	Electrolytic	4.7μF	25V
C16 L,R	0274016	Mylar, film	6800pF ±10%	50V	C619	0252615	Electrolytic	4.7μF	25V
C17 L,R	0252521	Electrolytic	10μF	16V	<b>RESISTORS</b>				
C18 L,R	0209734	Ceramic, discal	3300pF ±10%	50V	R1 L,R	0129641	Carbon film	27kΩ ±5%	SRD 1/4P
C19	0252533	Electrolytic	330μF	16V	R2 L,R	0129677	Carbon film	470kΩ ±5%	SRD 1/4P
C20 L,R	0252802	Electrolytic	0.22μF	50V	R3 L,R	0129613	Carbon film	3.3kΩ ±5%	SRD 1/4P
C21 L,R	0252521	Electrolytic	10μF	16V	R4 L,R	0129635	Carbon film	15kΩ ±5%	SRD 1/4P
C22 L,R	0252521	Electrolytic	10μF	16V	R5 L,R	0129709	Carbon film	2.2MΩ ±5%	SRD 1/4P
C23 L,R	0252521	Electrolytic	10μF	16V	R6 L,R	0129533	Carbon film	12Ω ±5%	SRD 1/4P
C24 L,R	0275013	Mylar, film	0.022μF ±10%	50V	R7 L,R	0129633	Carbon film	12kΩ ±5%	SRD 1/4P
C26 L,R	0275011	Mylar, film	0.01μF ±10%	50V	R8 L,R	0129661	Carbon film	100kΩ ±5%	SRD 1/4P
C27 L,R	0275012	Mylar, film	0.015μF ±10%	50V	R9	0129581	Carbon film	680Ω ±5%	SRD 1/4P
C28 L,R	0275014	Mylar, film	0.033μF ±10%	50V	R11 L,R	0129661	Carbon film	100kΩ ±5%	SRD 1/4P
C29 L,R	0209733	Ceramic, discal	2200pF ±10%	50V	R12 L,R	0129631	Carbon film	10kΩ ±5%	SRD 1/4P
C30	0209731	Ceramic, discal	1000pF ±10%	50V	R13 L,R	0129613	Carbon film	3.3kΩ ±5%	SRD 1/4P
C31	0252811	Electrolytic	1μF	50V	R14 L,R	0129679	Carbon film	560kΩ ±5%	SRD 1/4P
C32	0256521	Electrolytic	0.15μF	25V	R15 L,R	0129619	Carbon film	5.6kΩ ±5%	SRD 1/4P
C33	0252811	Electrolytic	1μF	50V	R16	0129603	Carbon film	1.2kΩ ±5%	SRD 1/4P
C34	0252531	Electrolytic	100μF	16V	R17	0129601	Carbon film	1kΩ ±5%	SRD 1/4P
C36	0252331	Electrolytic	100μF	10V	R18 L,R	0129545	Carbon film	39Ω ±5%	SRD 1/4P
C37 L,R	0209733	Ceramic, discal	2200pF ±10%	50V	R19 L,R	0129661	Carbon film	100kΩ ±5%	SRD 1/4P
C38 L,R	0208692	Ceramic, discal	220pF ±5%	50V	R20 L,R	0129619	Carbon film	5.6kΩ ±5%	SRD 1/4P
C39 L,R	0209731	Ceramic, discal	1000pF ±10%	50V	R21	0129579	Carbon film	560Ω ±5%	SRD 1/4P
C40 L,R	0208684	Ceramic, discal	100pF ±5%	50V	R22 L,R	0129631	Carbon film	10kΩ ±5%	SRD 1/4P
C303 L,R	0252813	Electrolytic	3.3μF	50V	R23 L,R	0129631	Carbon film	10kΩ ±5%	SRD 1/4P
C304 L,R	0252332	Electrolytic	220μF	10V	R24 L,R	0129679	Carbon film	560kΩ ±5%	SRD 1/4P
C305	0252813	Electrolytic	3.3μF	50V	R25	0129649	Carbon film	56kΩ ±5%	SRD 1/4P
C306	0252521	Electrolytic	10μF	16V	R26	0129573	Carbon film	330Ω ±5%	SRD 1/4P
C307	0244173	Ceramic, discal	0.022μF ±5%	50V	R27 L,R	0129669	Carbon film	220kΩ ±5%	SRD 1/4P
C308	0244173	Ceramic, discal	0.022μF ±5%	50V	R28 L,R	0129619	Carbon film	5.6kΩ ±5%	SRD 1/4P
C401	0268435	Mylar, film	0.015μF ±5%	100V	R29 L,R	0129615	Carbon film	3.9kΩ ±5%	SRD 1/4P
C402	0209734	Ceramic, discal	3300pF ±10%	50V	R30 L,R	0129621	Carbon film	6.8kΩ ±5%	SRD 1/4P
C403	0252525	Electrolytic	47μF	16V	R31 L,R	0129631	Carbon film	10kΩ ±5%	SRD 1/4P
C404	0252813	Electrolytic	3.3μF	50V	R32 L,R	0129647	Carbon film	47kΩ ±5%	SRD 1/4P
C405	0252531	Electrolytic	100μF	16V	R33 L,R	0129603	Carbon film	1.2kΩ ±5%	SRD 1/4P
C406	0275032	Mylar, film	0.018μF ±10%	50V	R34 L,R	0129553	Carbon film	82Ω ±5%	SRD 1/4P
C501	0209731	Ceramic, discal	1000pF ±10%	50V	R35 L,R	0129635	Carbon film	15kΩ ±5%	SRD 1/4P
C502	0252811	Electrolytic	1μF	50V	R36 L,R	0129607	Carbon film	1.8kΩ ±5%	SRD 1/4P
C503	0252805	Electrolytic	0.47μF	50V	R37 L,R	0129631	Carbon film	10kΩ ±5%	SRD 1/4P
C505	0252325	Electrolytic	47μF	10V	R38 L,R	0129611	Carbon film	2.7kΩ ±5%	SRD 1/4P
C506	0252331	Electrolytic	100μF	10V	R39 L,R	0129613	Carbon film	3.3kΩ ±5%	SRD 1/4P
C507	0252811	Electrolytic	1μF	50V	R40 L,R	0129631	Carbon film	10kΩ ±5%	SRD 1/4P
△C601	0256281	Electrolytic	3300μF	25V	R41 L,R	0129617	Carbon film	4.7kΩ ±5%	SRD 1/4P
△C602	0256281	Electrolytic	3300μF	25V	R42 L,R	0129553	Carbon film	82Ω ±5%	SRD 1/4P
					R43 L,R	0129607	Carbon film	1.8kΩ ±5%	SRD 1/4P
					R44	0129613	Carbon film	3.3kΩ ±5%	SRD 1/4P
					R45	0129643	Carbon film	33kΩ ±5%	SRD 1/4P
					R46 L,R	0129667	Carbon film	180kΩ ±5%	SRD 1/4P



SYMBOL No.	PART No.	DESCRIPTION			SYMBOL No.	PART No.	DESCRIPTION				
R47 L,R	0129647	Carbon film	47kΩ	±5%	SRD 1/4P	R531	0129649	Carbon film	56kΩ	±5%	SRD 1/4P
R48	0129643	Carbon film	33kΩ	±5%	SRD 1/4P	R532	0129601	Carbon film	1kΩ	±5%	SRD 1/4P
R49	0129643	Carbon film	33kΩ	±5%	SRD 1/4P	}	}	}	}	}	}
R50	0129609	Carbon film	2.2kΩ	±5%	SRD 1/4P	R535	0129601	Carbon film	1kΩ	±5%	SRD 1/4P
R51	0129645	Carbon film	39kΩ	±5%	SRD 1/4P	R536	0129679	Carbon film	560kΩ	±5%	SRD 1/4P
R52	0129671	Carbon film	270kΩ	±5%	SRD 1/4P	R537	0129619	Carbon film	5.6kΩ	±5%	SRD 1/4P
R53	0129605	Carbon film	1.5kΩ	±5%	SRD 1/4P	R538	0129619	Carbon film	5.6kΩ	±5%	SRD 1/4P
R54	0129609	Carbon film	2.2kΩ	±5%	SRD 1/4P	R539	0129643	Carbon film	33kΩ	±5%	SRD 1/4P
R56	0129643	Carbon film	33kΩ	±5%	SRD 1/4P	R540	0129643	Carbon film	33kΩ	±5%	SRD 1/4P
R57	0129601	Carbon film	1kΩ	±5%	SRD 1/4P	R541	0129623	Carbon film	8.3kΩ	±5%	SRD 1/4P
R58	0129631	Carbon film	10kΩ	±5%	SRD 1/4P	R542	0129631	Carbon film	10kΩ	±5%	SRD 1/4P
R60 L,R	0129846	Carbon film	100Ω	±5%	SRD 1/4P	R543	0129649	Carbon film	56kΩ	±5%	SRD 1/4P
R61	0129651	Carbon film	68kΩ	±5%	SRD 1/4P	R544	0129649	Carbon film	56kΩ	±5%	SRD 1/4P
R62	0129605	Carbon film	1kΩ	±5%	SRD 1/4P	R545	0129661	Carbon film	100kΩ	±5%	SRD 1/4P
R63 L,R	0129637	Carbon film	18kΩ	±5%	SRD 1/4P	R547	0129898	Carbon film	15kΩ	±5%	SRD 1/4P
R302	0129643	Carbon film	33kΩ	±5%	SRD 1/4P	R548	0129916	Carbon film	82kΩ	±5%	SRD 1/4P
R303	0129621	Carbon film	6.8kΩ	±5%	SRD 1/4P	R549	0129635	Carbon film	15kΩ	±5%	SRD 1/4P
R304	0129623	Carbon film	8.2kΩ	±5%	SRD 1/4P	R550	0129876	Carbon film	1.8kΩ	±5%	SRD 1/4P
R305	0129639	Carbon film	22kΩ	±5%	SRD 1/4P	R551	0129906	Carbon film	33kΩ	±5%	SRD 1/4P
R306	0129643	Carbon film	33kΩ	±5%	SRD 1/4P	R552	0129639	Carbon film	22kΩ	±5%	SRD 1/4P
R307	0129639	Carbon film	22kΩ	±5%	SRD 1/4P	R553	0129643	Carbon film	33kΩ	±5%	SRD 1/4P
R308	0129870	Carbon film	1kΩ	±5%	SRD 1/4P	R602	0119405	Metal oxide	22Ω	±10%	RS 1B
R401	0129623	Carbon film	8.2kΩ	±5%	SRD 1/4P	R607	0129579	Carbon film	560Ω	±5%	SRD 1/4P
R402	0129515	Carbon film	3.9Ω	±5%	SRD 1/4P	R608	0129577	Carbon film	470Ω	±5%	SRD 1/4P
R403	0129601	Carbon film	1kΩ	±5%	SRD 1/4P	R610	0129607	Carbon film	1.8kΩ	±5%	SRD 1/4P
R404	0129545	Carbon film	39Ω	±5%	SRD 1/4P	R611	0129519	Carbon film	220Ω	±5%	SRD 1/4P
R405	0129613	Carbon film	3.3kΩ	±5%	SRD 1/4P	R612	0129631	Carbon film	10kΩ	±5%	SRD 1/4P
R406	0129643	Carbon film	33kΩ	±5%	SRD 1/4P	R613	0129609	Carbon film	2.2kΩ	±5%	SRD 1/4P
R407	0129583	Carbon film	820Ω	±5%	SRD 1/4P	R614	0119048	Metal	39Ω	±10%	RN 1B
R408	0129605	Carbon film	1.5kΩ	±5%	SRD 1/4P	R615	0129613	Carbon film	3.3kΩ	±5%	SRD 1/4P
R409	0129631	Carbon film	10kΩ	±5%	SRD 1/4P	R701	0129619	Carbon film	5.6kΩ	±5%	SRD 1/4P
R410	0129645	Carbon film	39Ω	±5%	SRD 1/4P	R702	0129609	Carbon film	2.2kΩ	±5%	SRD 1/4P
R411	0129637	Carbon film	18kΩ	±5%	SRD 1/4P	R703	0129643	Carbon film	33kΩ	±5%	SRD 1/4P
R412	0129645	Carbon film	39kΩ	±5%	SRD 1/4P	R704	0129583	Carbon film	820Ω	±5%	SRD 1/4P
R413	0129645	Carbon film	39kΩ	±5%	SRD 1/4P	R705	0129583	Carbon film	820Ω	±5%	SRD 1/4P
R414	0129637	Carbon film	18kΩ	±5%	SRD 1/4P	R706	0129605	Carbon film	1.5kΩ	±5%	SRD 1/4P
△R415	0110607	Metal(Fuse resistor)	33Ω	±5%	RN 1/4B	<b>ICs &amp; TRANSISTORS</b>					
R501	0129643	Carbon film	33kΩ	±5%	SRD 1/4P	IC1	2369961	BA3302			
}	}	}	}	}	}	IC2	2368463	BA335			
R509	0129643	Carbon film	33kΩ	±5%	SRD 1/4P	IC3	2369351	μPC 4557C			
R510	0129635	Carbon film	15kΩ	±5%	SRD 1/4P	IC501	2387251	μPD553C			
R511	0129635	Carbon film	15kΩ	±5%	SRD 1/4P	IC502	2369951	TD62504P			
R512	0129643	Carbon film	33kΩ	±5%	SRD 1/4P	IC503	2369951	TD62504P			
R513	0129643	Carbon film	33kΩ	±5%	SRD 1/4P	IC601	2369931	BA6109			
R514	0129631	Carbon film	10kΩ	±5%	SRD 1/4P	IC602	2369931	BA6109			
R515	0129643	Carbon film	33kΩ	±5%	SRD 1/4P	Q1 L,R	2329388	2SC1740LN-SE			
R516	0129631	Carbon film	10kΩ	±5%	SRD 1/4P	Q2 L,R	2329388	2SC1740LN-SE			
R517	0129631	Carbon film	10kΩ	±5%	SRD 1/4P	Q3 L,R	2328283	2SC458			
R518	0129643	Carbon film	33kΩ	±5%	SRD 1/4P	Q4 L,R	2329561	2SC1845EF			
}	}	}	}	}	Q5	2329561	2SC1845EF				
R521	0129643	Carbon film	33kΩ	±5%	SRD 1/4P	Q6 L,R	2329316	2SC1741QR			
R522	0129649	Carbon film	56kΩ	±5%	SRD 1/4P	Q7 L,R	2329388	2SC1740LN-SE			
R523	0129605	Carbon film	1.5kΩ	±5%	SRD 1/4P	Q8 L,R	2329534	2SD467BC			
R524	0129631	Carbon film	10kΩ	±5%	SRD 1/4P	Q9	2328283	2SC458			
R527	0129601	Carbon film	1kΩ	±5%	SRD 1/4P	Q10	2328283	2SC458			
R528	0129649	Carbon film	56kΩ	±5%	SRD 1/4P						
R529	0129631	Carbon film	10kΩ	±5%	SRD 1/4P						
R530	0129609	Carbon film	2.2kΩ	±5%	SRD 1/4P						

SYMBOL No.	PART No.	DESCRIPTION
Q11 L,R	2329316	2SC1741OR
Q12	2328283	2SC458
Q13	2329571	2SA992FE
Q301	2328283	2SC458
Q302	2328283	2SC458
Q401	2328636	2SD667D
Q402	2328003	2SD468C
Q403	2328283	2SC458
Q404	2328283	2SC458
Q501	2328283	2SC458
Q503	2328283	2SC458
Q505	2328283	2SC458
Q509	2328283	2SC458
Q510	2329553	2SC2603EF
Q601	2329388	2SC1740LN-SE
Q602	2317738	2SD330AL
Q603	2317738	2SD330AL
Q604	2328452	2SB646

**DIODES**

D1	2338013	1S2473
D2	2338081	1S2473TAPE
D10	2338081	1S2473TAPE
D301	2338081	1S2473TAPE
D501	2338081	1S2473TAPE
D516	2338081	1S2473TAPE
D517	2338011	1S2473VE
D605	2337762	ERB12-01R
D607	2337762	ERB12-01R
D611	2337762	ERB12-01R
D701	2338081	1S2473TAPE
D705	2338081	1S2473TAPE
D706	2338013	1S2473
ZD1	2337731	HZ-7A
ZD501	2327523	HZ-9A-3
ZD502	2327545	HZ-7B-2
ZD503	2337101	HZ-12A
ZD601	2337555	HZ-11B-2
ZD602	2337629	HZ-4C3
ZD603	2337519	HZ-6C3
ZD604	2337189	HZ-15-3
ZD605	2337555	HZ-11B2
ZD606	2337555	HZ-11B2
ZD607	2337183	HZ20
ZD608	2337627	HZ-4C-1

SYMBOL No.	PART No.	DESCRIPTION
ZD609	2337615	HZ-3B2
LED701	2339021	TLG123A
LED702	2339021	TLG123A
LED703	2339031	SLR-34URS
LED704	2339021	TLG123A
LED705	2339841	GL-9PR4
LED706	2339841	GL-9PR4
LED707	2339841	GL-9PR4
LED708	2339021	TLG123A
LED709	2339021	TLG123A
LED710	2339021	TLG123A

**VARIABLE RESISTORS**

RT1 L,R	0150959	20kΩ-(B) (for PLAYBACK gain adjustment)
RT2 L,R	0150958	10kΩ-(B) (for PLAYBACK level adjustment)
RT3 L,R	0150961	100kΩ-(B) (for BIAS current adjustment)
RT4 L,R	01509 9	20kΩ-(B) (for METER adjustment)
RV2	0199511	10kΩ-(B) (for OUTPUT level adjustment)

**COILS**

L1	2136391	Bias OSC coil
L2 L,R	2227754	Choke coil (3.3mH)
L3	2154823	IC OSC coil
LC1 L,R	2135334	Dolby filter
LC2 L,R	2135624	Trap coil
LC3 L,R	2135622	Trap coil

**MISCELLANEOUS**

△S001	2639062	Power switch (for U.S.A. & Canada)
△S001	2639063	Power switch (except U.S.A., Canada & W. Germany)
△S001	2639063	Power switch (for W. Germany)
MOD1	2377431	Module TM3501
VR1	0166641	Slide volume
S301	2639038	Push switch (DOLBY ON/OFF)
S501	2638948	Push switch (MODE)
S701	2639121	Key switch (OPERATION button)
S708	2639121	Key switch (OPERATION button)
S709	2638241	Key switch (COUNTER RESET, others)
S712	2638241	Key switch (COUNTER RESET, others)
S713	2627821	Slide switch (TIMER)
JK1	2678024	Mic jack
JK2 L,R,	2678031	4P US pin jack (INPUT, OUTPUT TERMINAL)
JK3 L,R		
JK4	2657961	8P DIN socket
△F1	2727891	Fuse-T1.6A (for U.S.A. & Canada)
△F2	2727913	Fuse-T0.8A (for U.S.A. & Canada)
△F1	2727194	Fuse-T1.6A (except U.S.A. & Canada)
△F2	2727198	Fuse-T800mA (except U.S.A. & Canada)
△S002	2618373	Rotary switch (VOLTAGE SELECTOR) (for W. Germany)
	2727803	Fuse holder
△F3	2727788	Fuse-T500mA (for W. Germany)





**HITACHI SALES CORPORATION OF AMERICA**

**Eastern Regional Office**

1200 Wall Street West, Lyndhurst, New Jersey  
07071, U.S.A.

Tel. 201-935-8980

**Mid-Western Regional Office**

1400 Morse Ave., Elk Grove Village, Ill. 60007, U.S.A.  
Tel. 312-593-1550

**Southern Regional Office**

510 Plaza Drive College Park, Georgia 30349, U.S.A.  
Tel. 404-763-0360

**Western Regional Office**

401 West Artesia Boulevard, Compton, California  
90220, U.S.A.

Tel. 213-537-8383

**HITACHI SALES CORPORATION OF HAWAII, INC.**

3219 Koapaka Street Honolulu, Hawaii 96819, U.S.A.  
Tel. 808-836-3621

**HITACHI (HSC) CANADA INC.**

3300 Trans Canada Highway, Pointe Claire, Quebec  
H9R 1B1, Canada

Tel. 514-697-9150

**HITACHI SALES EUROPA GmbH**

2050 Hamburg 80, Rungedamm 2, West Germany  
Tel. 73411-0

**HITACHI SALES (U.K.) Ltd.**

Hitachi House, Station Road, Hayes, Middlesex UB3  
4DR, England

Tel. 01-848-8787 (Service Centre: 01-848-3551)

**HITACHI SALES SCANDINAVIA AB**

Rissneleden 8, Box 7138, 172-07 Sundbyberg,  
Sweden

Tel. 08-98 52 80

**HITACHI SALES NORWAY A/S**

Oerebekk 1620 Gressvik P.O. Box 46 N-1601  
Fredrikstad, Norway

Tel. 032-28255

**SUOMEN HITACHI OY**

Takoankatsu 5, 15800 Lahti 80, Finland  
Tel. Lahti 44 241

**HITACHI SALES A/S**

Kuldysen 13, DK-2630 Taastrup, Denmark  
Tel. 02-999200

**HITACHI SALES A.G.**

Bahnhofstrasse, 19, 5600 Lenzburg,  
Switzerland

Tel. 064-513621

**HITACHI FRANCE S.A.**

97/115 Rue Charles-Michels 93200  
SAINT-DENIS, France

Tel. 201-25-00

**HITACHI SALES WARENHANDELS GMBH**

A-1180/Wien, Kreuzgasse 27, Austria  
Tel. (0222) 439367/8

**HITACHI SALES BELGIUM S.A./N.V.**

56, Chaussee de Namur, B-1400  
Nivelles, Belgium

Tel. (067) 22 71 81

**HITACHI SALES AUSTRALIA Pty Ltd.**

153 Keys Road, Moorabbin, Victoria 3189 Australia  
Tel. 555-8722

**HITACHI Ltd. TOKYO JAPAN**

Head Office: 5-1, 1-chome, Marunouchi, Chiyoda-  
ku, Tokyo 100, Japan  
Tel. Tokyo (212) 1111

Cable Address: "HITACHY" TOKYO



# HITACHI

## SERVICE MANUAL

TY

No. 353EGF-1

**D-RV7**  
(U, C, FS, BS, AU, W)

### REVISED VERSION

This revised version of the CASSETTE CHASSIS REPLACEMENT PARTS LIST is to substitute the same contained in the SERVICE MANUAL No. 353EGF for Model D-RV7 since the previous issue had some incorrect description. Please use this revised version jointly with the previously issued service manual for Model D-RV7.

Diese revidierte Version der CASSETTEN-CHASSIS-ERSATZTEILLISTE ersetzt die Liste, die im WARTUNGSHANDBUCH Nr. 353EGF für das Modell D-RV7 enthalten ist, da die vorige Ausgabe einige fehlerhafte Beschreibungen enthält. Bitte verwenden Sie diese revidierte Version zusammen mit dem vorher ausgegebenen Wartungshandbuch für das Modell D-RV7.

Cette version révisée de la LISTE DES PIECES DE REMPLACEMENT DU CHASSIS DE CASSETTE remplace celle qui est contenue dans le MANUEL DE SERVICE No. 353EGF pour le Modèle D-RV7, car la première édition présente certaines erreurs. Nous vous recommandons par conséquent d'utiliser cette version révisée conjointement avec le manuel de service publié précédemment pour le modèle D-RV7.

SPECIFICATIONS AND PARTS ARE SUBJECT TO CHANGE FOR IMPROVEMENT.

## STEREO CASSETTE TAPE DECK

March 1983

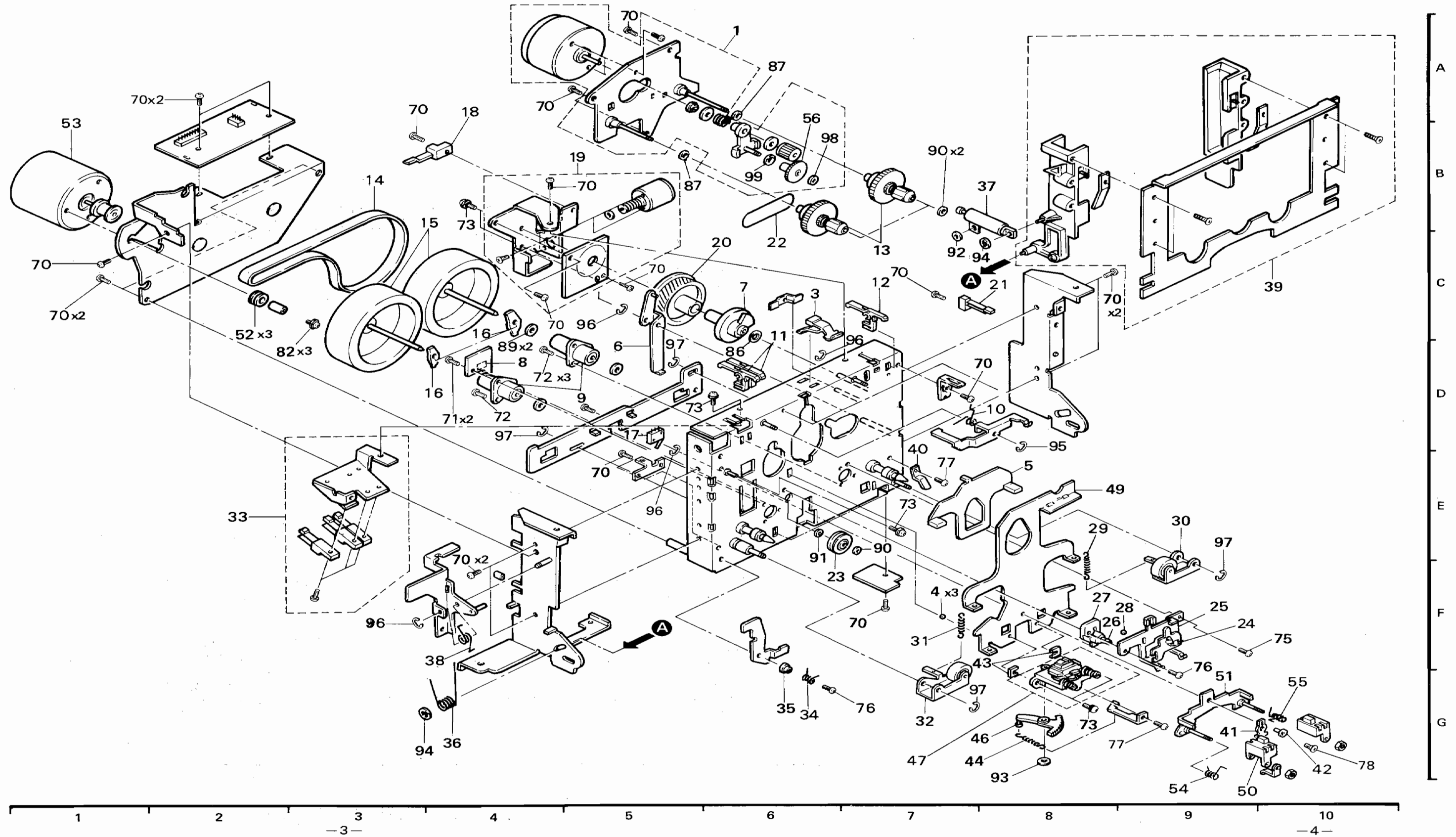
TOYOKAWA WORKS

## REPLACEMENT PARTS LIST · ERSATZTEILLISTE · TABLEAU DES PIÈCES

## CASSETTE CHASSIS

ITEM No.	PART No.	DESCRIPTION	ITEM No.	PART No.	DESCRIPTION
1	4022951	Motor holder ass'y	44	3365301	Spring for take up coil
3	4450741	Cassette holder spring	46	3958471	Reverse gear
4	4586031	Ball (2 $\phi$ )	47	4023721	RECORD/PLAYBACK & ERASE head ass'y
5	4022793	Brake plate ass'y	49	4022931	Head base
6	4022811	Select lever ass'y	50	2789331	Tape guide L (with photo transistor)
7	3958331	Cam	51	4022941	Change plate ass'y
8	4996931	LED TLR121	52	4690541	Motor rubber
9	4022851	C stand ass'y	53	4088731	C motor ass'y
10	3364911	Twist coil spring	54	3365011	Compress coil spring (L)
11	3958341	REC lever (F) (Black)	55	3365001	Compress coil spring (R)
12	3958351	Rec lever (R) (White)	56	3958521	Gear
13	4022821	Reel base ass'y	70	4996631	2.5 $\phi$ x 5 screw
14	4690511	Belt	71	4996842	2.6 $\phi$ x 6 screw
15	3357191	Flywheel	72	4996841	2.6 $\phi$ x 5 screw
16	4450491	Thrust spring	73	4996681	2 $\phi$ x 4 screw
17	4996871	Lever switch	74	4996691	2 $\phi$ x 3 screw
18	4996881	Leaf switch	75	4996715	3 $\phi$ x 4 screw
19	4022752	PAD motor ass'y	76	4996632	2.5 $\phi$ x 8 screw
20	4022831	Rotary gear ass'y	77	4996751	2 $\phi$ x 3.2 screw
21	4996891	Leaf switch	78	4996793	2 $\phi$ x 6 flat screw
22	4690527	Belt	82	4996761	Screw
23	3347161	Pulley	84	4996647	Washer
24	4022841	Lamp ass'y	85	4996643	Washer
25	4450551	Head plate holder	86	4996831	Washer (4.1 $\phi$ )
26	3958411	Half guide	87	4996649	Washer (3.1 $\phi$ )
27	3958421	Guide base	89	4996646	Washer (2.6 $\phi$ )
28	4586033	Ball (3 $\phi$ )	90	4996642	Washer (1.8 $\phi$ )
29	3364931	Coil spring (R) (for pinch arm ass'y, F)	91	4996648	Washer (2.1 $\phi$ )
30	4022861	Pinch arm ass'y (F)	92	4996851	Washer (2.2 $\phi$ )
31	3364941	Coil spring (L) (for pinch arm ass'y, R)	93	4997888	Washer
32	4022871	Pinch arm ass'y (R)	94	4996731	Washer
33	4996951	Leaf switch ass'y	95	4996621	2.5 $\phi$ E ring
34	3364951	Spring	96	4996622	3 $\phi$ E ring
35	4586181	Collar	97	4996651	2 $\phi$ E ring
36	3364961	Coil spring	98	4997886	Washer (1.3 $\phi$ )
37	3960411	Damper unit	99	4997887	Washer (1.7 $\phi$ )
38	3364971	Coil spring			
39	4022891	Cassette holder ass'y			
40	4450611	Cassette spring			
41	4450641	Spring			
42	4586241	Collar			
43	4450751	Spacer			

EXPLODED VIEW (Cassette chassis: PAD-121R) · EXPLOSIONSANSICHT (Chassetten-Tonbandgerät: PAD-121R) · VUE EXPLOSEE (Magnéphone: PAD-121R)  
(Nos. are reference Nos. of parts list.)





**HITACHI SALES CORPORATION OF AMERICA**  
**Eastern Regional Office**

1290 Wall Street West, Lyndhurst, New Jersey  
 07071, U.S.A.  
 Tel. 201-935-8980

**Mid Western Regional Office**

1400 Morse Ave., Elk Grove Village, Ill. 60007, U.S.A.  
 Tel. 312-593-1550

**Southern Regional Office**

510 Plaza Drive College Park, Georgia 30349, U.S.A.  
 Tel. 404-763-0360

**Western Regional Office**

401 West Artesia Boulevard, Compton, California  
 90220, U.S.A.  
 Tel. 213-537-8383

**HITACHI SALES CORPORATION OF HAWAII, INC.**

3219 Koapaka Street Honolulu, Hawaii 96819, U.S.A.  
 Tel. 808-836-3621

**HITACHI (HSC) CANADA INC.**

3300 Trans Canada Highway, Pointe Claire, Quebec  
 H9R 1B 1, Canada  
 Tel. 514-697-9150

**HITACHI SALES EUROPA GmbH**

2050 Hamburg 80, Rungedamm 2, West Germany  
 Tel. 73411-0

**HITACHI SALES (U.K.) Ltd.**

Hitachi House, Station Road, Hayes, Middlesex UB3  
 4DR, England  
 Tel. 01-848-8787 (Service Centre: 01-848-3551)

**HITACHI SALES SCANDINAVIA AB**

Rissneleden 8, Box 7138, 172 07 Sundbyberg,  
 Sweden  
 Tel. 08-98 52 80

**HITACHI SALES NORWAY A/S**

Oerebekk 1620 Gressvik P.O. Box 46N-1601  
 Fredrikstad, Norway  
 Tel. 032-28255

**SUOMEN HITACHI OY**

Tako jankatsu 5, SF-15800 Lahti 80, Finland  
 Tel. 918-44241

**HITACHI SALES A/S**

Kuldysen 13, DK-2630 Taastrup, Denmark  
 Tel. 02-999200

**HITACHI SALES A.G.**

Bahnhofstrasse, 19, 5600 Lenzburg,  
 Switzerland  
 Tel. 064-513621

**HITACHI FRANCE S.A.**

95/101 Rue Charles - Michels 93200  
 SAINT-DENIS, France  
 Tel. 821-60-15

**HITACHI SALES WARENHANDELS GMBH**

A-1180/Wien, Kreuzgasse 27, Austria  
 Tel. (0222) 439367/8

**HITACHI SALES BELGIUM S.A./N.V.**

56, Chaussee de Namur, B-1400  
 Nivelles, Belgium  
 Tel. (067) 22 71 81

**HITACHI SALES AUSTRALIA Pty Ltd.**

153 Keys Road, Moorabbin, Victoria 3189 Australia  
 Tel. 555-8722

**HITACHI Ltd. TOKYO JAPAN**

Head Office: 5-1, 1-chome, Marunouchi, Chiyoda-  
 ku, Tokyo 100, Japan  
 Tel. Tokyo (212) 1111

Cable Address: "HITACHY" TOKYO