

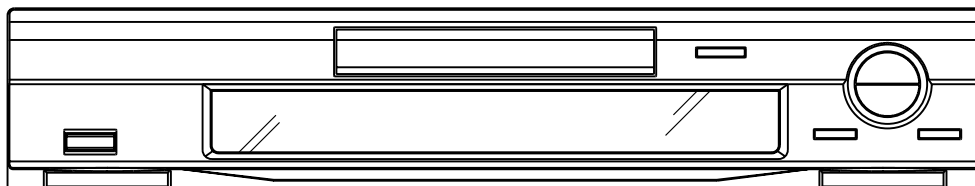

DV-C4

SERVICE MANUAL

DVD PLAYER



ORIGINAL

WAVEFORMS

MPEG

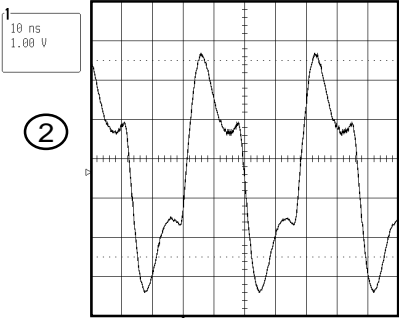
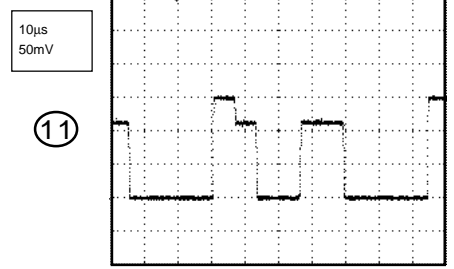
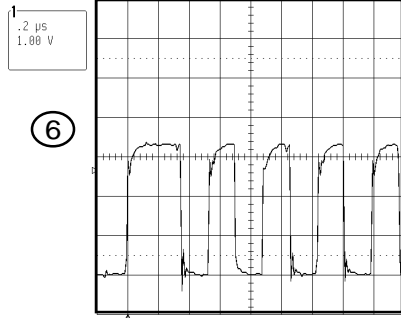
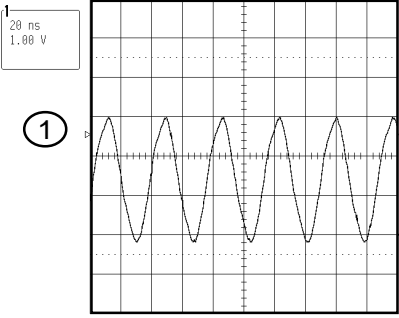

SDRAM

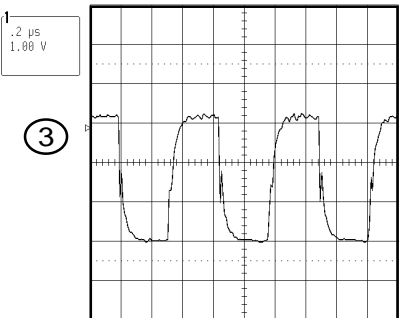
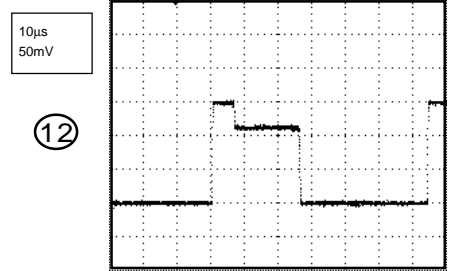
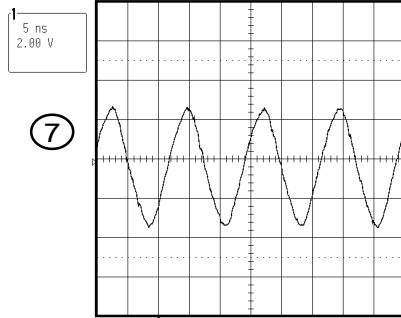

SYSCON

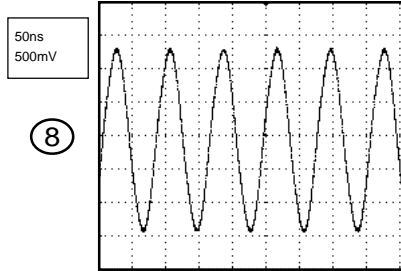

VIDEO AMP

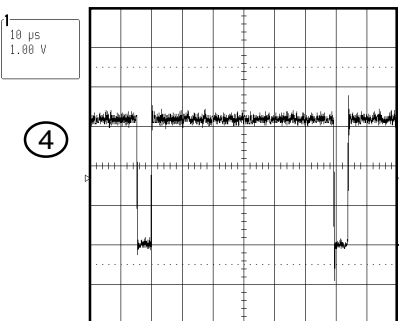
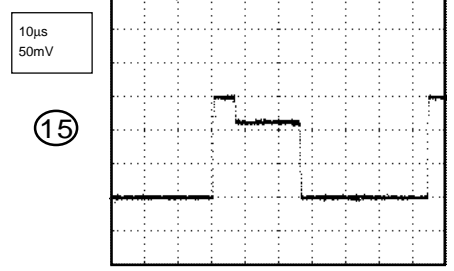

VIDEO ENCODER

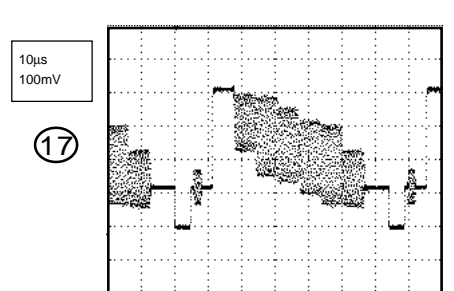
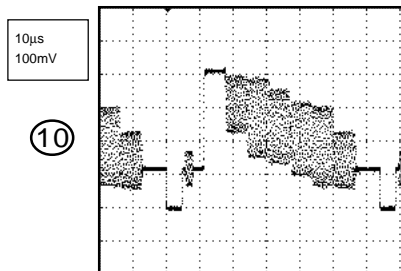
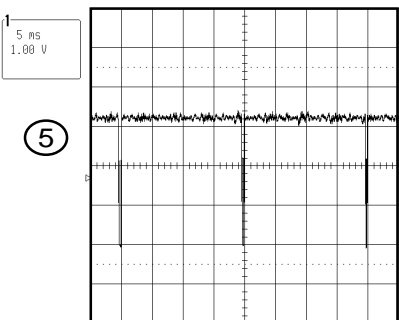
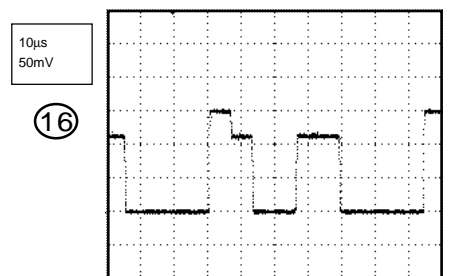
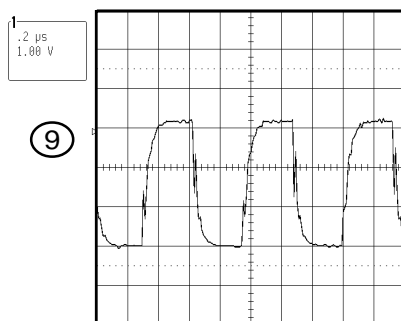

NOTE: The following waveforms were measured at the point of the corresponding balloon number in the schematic diagram.

WAVEFORMS

AUDIO

200 μ s
2.0V

18

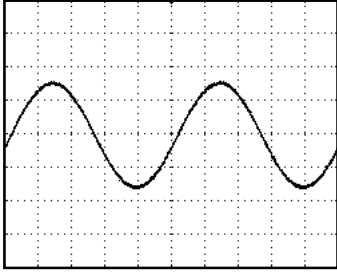

200 μ s
2.0V

19

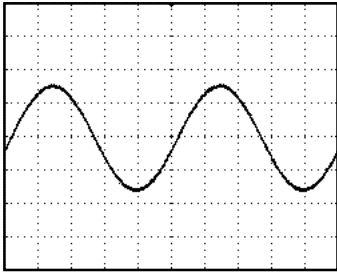

NOTE: The following waveforms were measured at the point of the corresponding balloon number in the schematic diagram.

MECHANICAL EXPLODED VIEW

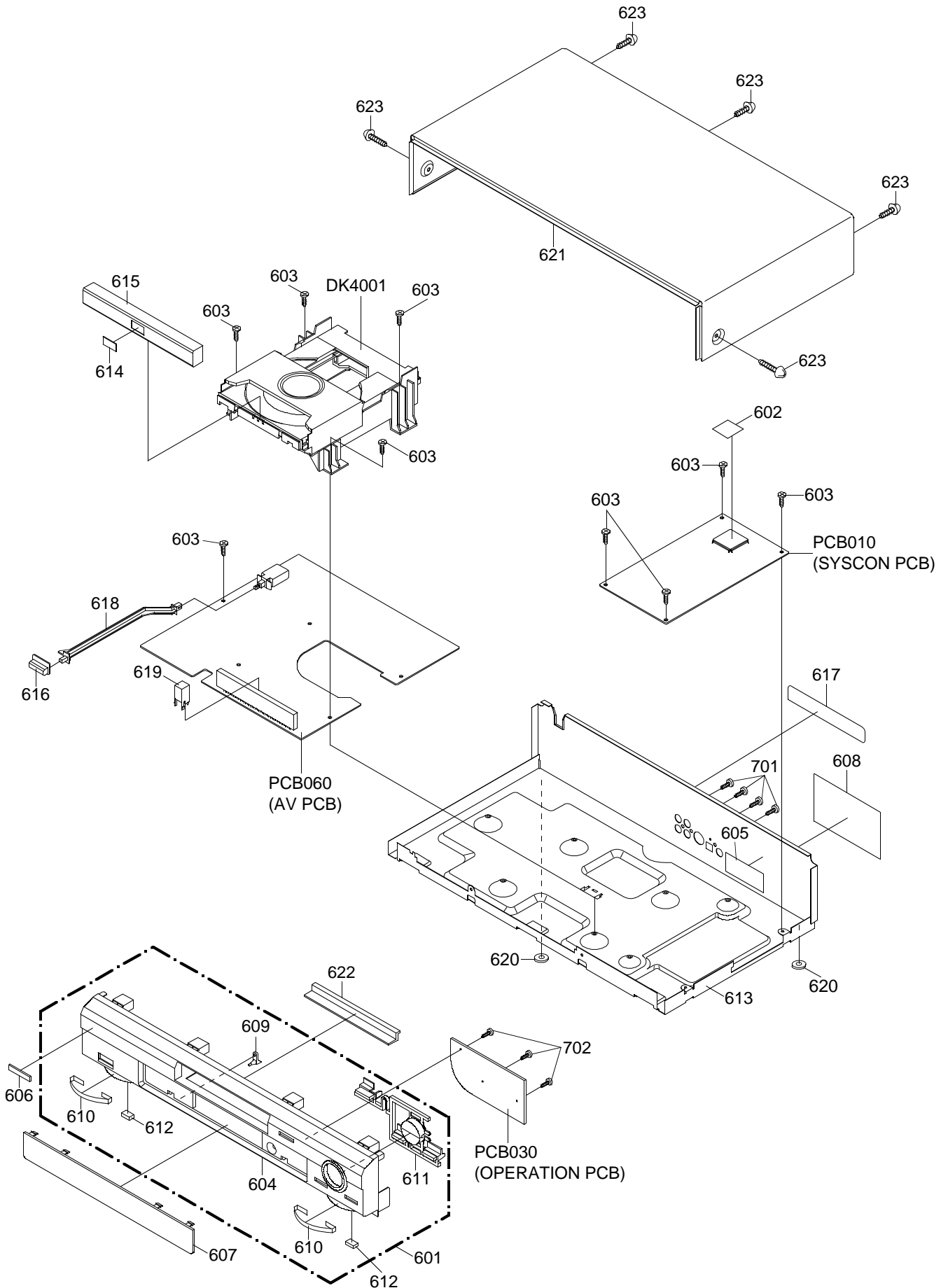

MECHANICAL REPLACEMENT PARTS LIST

REF. NO.	PART.NO	DESCRIPTION
601	A2A111A720E	CABINET,FRONT ASSY
602	7230007172	SHEET,IC
603	8109230904	SCREW,TAP TITE(B) R BIND 3x9
604	701WPJ1056	CABINET,FRONT
605	7260000332	SHEET,CAUTION
606	711WPCA033	BADGE,BRAND
607	711WPD0597	PLATE,DISPLAY
608	722528A008	SHEET,RATING
609	713WPA0150	GLASS,LED
610	723000A634	SHEET,LEG
611	735WPJ0186	BUTTON,FRAME
612	800WFA0045	CUSHION,LEG
613	702WSA0087	PLATE,BOTTOM
614	7235630001	SHEET,DVD(NEW)
615	712WPB0068	PLATE,TRAY-FRONT
616	735WPB0105	BUTTON,POWER
617	7230007344	SHEET,JACK
618	761WPA0213	SHAFT,POWER SW
619	761WPAA031	HOLDER,FIP
620	800WR00070	CUSHION FAI 23x13xT2
621	702WSB0049	CABINET,TOP
622	761WSA0078	ANGLE,TRAY
623	8109K30601	SCREW,TAP TITE(B) BIND(3D) 3x6
701	8110630604	SCREW,TAP TITE(P) BRAZIER 3x6
702	8110226804	SCREW,TAP TITE(P) BIND 2.6x8
---	791WHA0095	GIFT,SHEET
---	793WCD1354	GIFT BOX
---	JB5U0200	POLY & BAG
---	J2A11101	INSTRUCTION BOOK
---	J2A11102	WARRANTY CARD
---	A2A111A975	INSTRUCTION BOOK KIT

ELECTRICAL REPLACEMENT PARTS LIST

REF. NO.	PART.NO	DESCRIPTION	REF. NO.	PART.NO	DESCRIPTION
RESISTORS			RESISTORS		
△ R502	R011K2155J	RC 1.5M OHM 1/2W	R4010	R803R9101J	RC 100 OHM 1/16W
R503	R801R7101J	RC 100 OHM 1/10W	R4011	R803R9472J	RC 4.7K OHM 1/16W
R504	R0L2X4181J	RC 180 OHM 1/4W	R4012	R803R9472J	RC 4.7K OHM 1/16W
R505	R801R7272F	RC 2.7K OHM 1/10W	R4013	R803R9181J	RC 180 OHM 1/16W
R506	R801R7471J	RC 470 OHM 1/10W	R4014	R803R9181J	RC 180 OHM 1/16W
△ R507	R3X28A104J	R,METAL OXIDE 100K OHM 2W	R4015	R803R9181J	RC 180 OHM 1/16W
R509	R801R7223J	RC 22K OHM 1/10W	R4016	R803R9181J	RC 180 OHM 1/16W
R510	R801R7102J	RC 1K OHM 1/10W	R4017	R803R9181J	RC 180 OHM 1/16W
R514	R801R7103F	RC 10K OHM 1/10W	R4018	R803R9181J	RC 180 OHM 1/16W
R515	R0L2X46R8J	RC 6.8 OHM 1/4W	R4020	R803R9472J	RC 4.7K OHM 1/16W
R516	R801R7302F	RC 3K OHM 1/10W	R4021	R803R9105J	RC 1M OHM 1/16W
R518	R801R7332F	RC 3.3K OHM 1/10W	R4024	R803R9102J	RC 1K OHM 1/16W
R519	R0L2X2561J	RC 560 OHM 1/2W	R4025	R803R9101J	RC 100 OHM 1/16W
R521	R0L2X2101J	RC 100 OHM 1/2W	R4027	R803R9101J	RC 100 OHM 1/16W
R522	R0L2X4102J	RC 1K OHM 1/4W	R4028	R803R9101J	RC 100 OHM 1/16W
R523	R801R7102J	RC 1K OHM 1/10W	R4029	R803R9101J	RC 100 OHM 1/16W
△ R524	R3X28A561J	R,METAL 560 OHM 2W	R7004	R0L2X4103J	RC 10K OHM 1/4W
△ R525	R3X181221J	R,METAL OXIDE 220 OHM 1W	R7010	R801R7102J	RC 1K OHM 1/10W
R526	R801R7103J	RC 10K OHM 1/10W	R7011	R801R7474J	RC 470K OHM 1/10W
R527	R0L2X4221J	RC 220 OHM 1/4W	R7012	R801R7103J	RC 10K OHM 1/10W
R529	R0L2X2224J	RC 220K OHM 1/2W	R7014	R0L2X4103J	RC 10K OHM 1/4W
R530	R0L2X2224J	RC 220K OHM 1/2W	R7017	R801R7103J	RC 10K OHM 1/10W
R532	R801R7103J	RC 10K OHM 1/10W	R7021	R0L2X4472J	RC 4.7K OHM 1/4W
R537	R801R7103J	RC 10K OHM 1/10W	R7022	R801R7103J	RC 10K OHM 1/10W
R538	R801R7271J	RC 270 OHM 1/10W	R7023	R801R7100J	RC 10 OHM 1/10W
R539	R801R7331J	RC 330 OHM 1/10W	R7026	R801R7100J	RC 10 OHM 1/10W
R540	R801R7103J	RC 10K OHM 1/10W	R7028	R801R7103J	RC 10K OHM 1/10W
R541	R801R7103J	RC 10K OHM 1/10W	R7029	R801R7100J	RC 10 OHM 1/10W
△ R542	R3X1811R5J	R,METAL OXIDE 1.5 OHM 1W	R7030	R801R7103J	RC 10K OHM 1/10W
R543	R801R7271J	RC 270 OHM 1/10W	R7035	R801R7123J	RC 12K OHM 1/10W
R544	R801R7222F	RC 2.2K OHM 1/10W	R7036	R801R7123J	RC 12K OHM 1/10W
R545	R801R7103F	RC 10K OHM 1/10W	R7038	R801R7822J	RC 8.2K OHM 1/10W
R546	R801R7472J	RC 4.7K OHM 1/10W	R7039	R0L2X4102J	RC 1K OHM 1/4W
R547	R0L2X2561J	RC 560 OHM 1/2W	R7040	R801R7822J	RC 8.2K OHM 1/10W
R550	R801R7101J	RC 100 OHM 1/10W	R7041	R0L2X4102J	RC 1K OHM 1/4W
R651	R0L2X4151J	RC 150 OHM 1/4W	R7047	R0L2X4471J	RC 470 OHM 1/4W
R652	R0L2X4103J	RC 10K OHM 1/4W	R7048	R0L2X4103J	RC 10K OHM 1/4W
R653	R0L2X4103J	RC 10K OHM 1/4W	R7049	R801R7103J	RC 10K OHM 1/10W
R658	R801R7102J	RC 1K OHM 1/10W	R7050	R801R7332J	RC 3.3K OHM 1/10W
R659	R801R7104J	RC 100K OHM 1/10W	R7051	R0L2X4102J	RC 1K OHM 1/4W
R661	R0L2X4103J	RC 10K OHM 1/4W	R7052	R0L2X4102J	RC 1K OHM 1/4W
R663	R801R7223J	RC 22K OHM 1/10W	R7053	R801R7100J	RC 10 OHM 1/10W
R664	R801R7103J	RC 10K OHM 1/10W	R7054	R801R7121J	RC 120 OHM 1/10W
R665	R801R7103J	RC 10K OHM 1/10W	R7055	R801R7560J	RC 56 OHM 1/10W
R666	R801R7103J	RC 10K OHM 1/10W	R7056	R801R7104J	RC 100K OHM 1/10W
R1001	R803R9103J	RC 10K OHM 1/16W	R7057	R801R7104J	RC 100K OHM 1/10W
R1002	R803R9472J	RC 4.7K OHM 1/16W	R7058	R801R7102J	RC 1K OHM 1/10W
R1003	R803R9472J	RC 4.7K OHM 1/16W	R7059	R801R7102J	RC 1K OHM 1/10W
R1004	R803R9472J	RC 4.7K OHM 1/16W	R7060	R0L2X4471J	RC 470 OHM 1/4W
R1005	R803R9472J	RC 4.7K OHM 1/16W	R7071	R801R7471J	RC 470 OHM 1/10W
R1006	R803R9103J	RC 10K OHM 1/16W	R7072	R0L2X4471J	RC 470 OHM 1/4W
R1007	R803R9102J	RC 1K OHM 1/16W	R7073	R0L2X4750J	RC 75 OHM 1/4W
R1008	R803R9472J	RC 4.7K OHM 1/16W	R8001	R0L2X4680J	RC 68 OHM 1/4W
R1009	R803R9472J	RC 4.7K OHM 1/16W	R8008	R0L2X4103J	RC 10K OHM 1/4W
R1010	R803R9472J	RC 4.7K OHM 1/16W	R8009	R0L2X4680J	RC 68 OHM 1/4W
R1011	R803R9472J	RC 4.7K OHM 1/16W	R8010	R801R7330J	RC 33 OHM 1/10W
R1012	R803R9102J	RC 1K OHM 1/16W	R8014	R801R7330J	RC 33 OHM 1/10W
R1014	R803R9472J	RC 4.7K OHM 1/16W	R8021	R0L2X4750J	RC 75 OHM 1/4W
R1015	R803R9472J	RC 4.7K OHM 1/16W	R8034	R0L2X4150J	RC 15 OHM 1/4W
R1016	R803R9472J	RC 4.7K OHM 1/16W	R8035	R0L2X4150J	RC 15 OHM 1/4W
R1017	R803R9472J	RC 4.7K OHM 1/16W	R8501	R803R9393J	RC 39K OHM 1/16W
R1018	R803R9103J	RC 10K OHM 1/16W	R8502	R803R9103J	RC 10K OHM 1/16W
R1019	R803R9561J	RC 560 OHM 1/16W	R8503	R803R9103J	RC 10K OHM 1/16W
R1023	R803R9102J	RC 1K OHM 1/16W	R8504	R803R9750F	RC 75 OHM 1/16W
R1024	R803R9102J	RC 1K OHM 1/16W	R8505	R803R9750F	RC 75 OHM 1/16W
R1026	R803R9102J	RC 1K OHM 1/16W	R8507	R803R9750F	RC 75 OHM 1/16W
R1027	R803R9102J	RC 1K OHM 1/16W	R8508	R803R9750F	RC 75 OHM 1/16W
R1030	R803R9472J	RC 4.7K OHM 1/16W	R8509	R803R9103J	RC 10K OHM 1/16W
R4001	R803R92R2J	RC 2.2 OHM 1/16W	R8510	R803R9103J	RC 10K OHM 1/16W
R4002	R803R9472J	RC 4.7K OHM 1/16W	R8511	R803R9182J	RC 1.8K OHM 1/16W
R4003	R803R9472J	RC 4.7K OHM 1/16W	R8520	R803R9102J	RC 1K OHM 1/16W
R4004	R803R9472J	RC 4.7K OHM 1/16W	CAPACITORS		
R4005	R803R9181J	RC 180 OHM 1/16W	C501	C0JFE0514M	CC 0.01 UF 500V E
R4006	R803R9101J	RC 100 OHM 1/16W	C503	E02LT2471M	CE 470 UF 16V
R4007	R803R9181J	RC 180 OHM 1/16W	△ C504	P2472B224M	CMP 0.22UF 275V PHE840
R4008	R803R9181J	RC 180 OHM 1/16W	△ C505	P2472B104M	CMP 0.1 UF 275V PHE840
R4009	R803R9181J	RC 180 OHM 1/16W	△ C506	CB3930MH3M	CC 0.0022UF 250V

ELECTRICAL REPLACEMENT PARTS LIST

REF. NO.	PART.NO	DESCRIPTION	REF. NO.	PART.NO	DESCRIPTION
CAPACITORS			CAPACITORS		
C507	CS0RB0414K	CC 0.01 UF 50V B	C7056	CS0RCH4H2J	CC 220 PF 50V CH
C508	E02LFH470M	CE 47 UF 400V	C7057	E50HU54R7M	CE 4.7 UF 50V
C509	P6M9T0273J	CMPL 0.027 UF 50V TF	C7062	CS0RF0415Z	CC 0.1 UF 50V F
C510	CS0RB04S3K	CC 0.0056UF 50V B	C7063	E50HU0470M	CE 47 UF 6.3V
△ C511	CB3930MH3M	CC 0.0022UF 250V	C7064	CS0RB04H4K	CC 0.022 UF 50V B
C512	E50HU54R7M	CE 4.7 UF 50V	C7065	CS0RCH412J	CC 100 PF 50V CH
C513	E02LU5100M	CE 10 UF 50V	C7067	E62KU52R2M	CE 2.2 UF 50V
△ C514	E02LF3102M	CE 1000 UF 25V	C7068	E62KU52R2M	CE 2.2 UF 50V
C515	CS0RB0315K	CC 0.1 UF 25V B	C7069	E50HU52R2M	CE 2.2 UF 50V
△ C519	E02LT3331M	CE 330 UF 25V	C7070	E50HU52R2M	CE 2.2 UF 50V
△ C520	E02LF1222M	CE 2200 UF 10V	C7071	E50HU1330M	CE 33 UF 10 V
C521	E02LT0102M	CE 1000 UF 6.3V	C7079	CS0RF0415Z	CC 0.1 UF 50V F
C523	E50HU0220M	CE 22 UF 6.3V	C7080	CS0RB0414K	CC 0.01 UF 50V B
△ C524	E02LF2222M	CE 2200 UF 16V	C8001	CS0RCH4L2J	CC 330 PF 50V CH
△ C525	E02LU5470M	CE 47 UF 50V	C8002	CS0RB0315K	CC 0.1 UF 25V B
C528	CS0RF0415Z	CC 0.1 UF 50V F	C8003	E02LU0471M	CE 470 UF 6.3V
C530	C0JTB0612K	CC 100 PF 1KV B	C8004	E02LU0471M	CE 470 UF 6.3V
C531	CS0RB0414K	CC 0.01 UF 50V B	C8005	E02LU0101M	CE 100 UF 6.3V
C532	E02LU0221M	CE 220 UF 6.3V	C8006	E02LU0471M	CE 470 UF 6.3V
C533	E02LU0471M	CE 470 UF 6.3V	C8007	CS0RB0414K	CC 0.01 UF 50V B
△ C534	E02LU2470M	CE 47 UF 16V	C8008	CS0RB0414K	CC 0.01 UF 50V B
△ C535	E02LF3102M	CE 1000 UF 25V	C8013	CS0RB0414K	CC 0.01 UF 50V B
C536	E02LU0221M	CE 220 UF 6.3V	C8014	CS0RCH4L2J	CC 330 PF 50V CH
C537	E50HU54R7M	CE 4.7 UF 50V	C8016	CS0RCH4L2J	CC 330 PF 50V CH
C538	E02LT0102M	CE 1000 UF 6.3V	C8019	CS0RB0414K	CC 0.01 UF 50V B
△ C539	E02LU0331M	CE 330 UF 6.3V	C8020	CS0RCH4L1J	CC 33 PF 50V CH
C540	CS0RB0414K	CC 0.01 UF 50V B	C8501	CS0PF0315Z	CC 0.1 UF 25V F
C541	E50HU0220M	CE 22 UF 6.3V	C8502	CS0PF0315Z	CC 0.1 UF 25V F
C545	CS0RB0414K	CC 0.01 UF 50V B	C8503	E50HU0220M	CE 22 UF 6.3V
C651	CS0RF0415Z	CC 0.1 UF 50V F	C8504	CS0PF0315Z	CC 0.1 UF 25V F
C656	CS0RB0413K	CC 0.001 UF 50V B	C8505	E50HU0220M	CE 22 UF 6.3V
C661	CS0RF0415Z	CC 0.1 UF 50V F	C8506	CS0PF0315Z	CC 0.1 UF 25V F
C663	E02LU0471M	CE 470 UF 6.3V	C8507	CS0PF0315Z	CC 0.1 UF 25V F
C664	CS0RF0415Z	CC 0.1 UF 50V F	C8508	CS0PF0315Z	CC 0.1 UF 25V F
C1001	CS0PF0315Z	CC 0.1 UF 25V F	C8509	E02LU0221M	CE 220 UF 6.3V
C1002	CS0PCH4G1J	CC 18 PF 50V CH	C8510	CS0PF0315Z	CC 0.1 UF 25V F
C1003	CS0PCH4G1J	CC 18 PF 50V CH	C8511	CS0PF0315Z	CC 0.1 UF 25V F
C1004	E02LU0471M	CE 470 UF 6.3V	C8512	CS0PF0315Z	CC 0.1 UF 25V F
C1006	CS0PF0315Z	CC 0.1 UF 25V F	C8514	E02LU0221M	CE 220 UF 6.3V
C1007	E02LU0221M	CE 220 UF 6.3V	C8515	CS0PF0315Z	CC 0.1 UF 25V F
C1008	CS0PF0315Z	CC 0.1 UF 25V F	C8517	CS0PCH4H1J	CC 22 PF 50V CH
C1010	CS0PB03H4K	CC 0.022 UF 25V B	C8519	CS0PCH4K2J	CC 270 PF 50V CH
C1014	CS0PF0315Z	CC 0.1 UF 25V F	C8521	CS0PCH4L2J	CC 330 PF 50V CH
C4001	CS0PF0315Z	CC 0.1 UF 25V F	C8523	E50HU0470M	CE 47 UF 6.3V
C4002	CS0PF0315Z	CC 0.1 UF 25V F	C8524	CS0PF0315Z	CC 0.1 UF 25V F
C4003	CS0PF0315Z	CC 0.1 UF 25V F	C8525	CS0PCH4H1J	CC 22 PF 50V CH
C4004	CS0PF0315Z	CC 0.1 UF 25V F	C8526	CS0PCH4H1J	CC 22 PF 50V CH
C4005	CS0PF0315Z	CC 0.1 UF 25V F	C8527	CS0PCH4K2J	CC 270 PF 50V CH
C4006	CS0PF0315Z	CC 0.1 UF 25V F	C8528	CS0PCH4K2J	CC 270 PF 50V CH
C4007	CS0PB0413K	CC 0.001 UF 50V B	C8529	CS0PCH4L2J	CC 330 PF 50V CH
C4008	E02LU0221M	CE 220 UF 6.3V	C8530	CS0PCH4L2J	CC 330 PF 50V CH
C4009	CS0PB02Q4K	CC 0.047 UF 16V B	C8532	E50HU0470M	CE 47 UF 6.3V
C4010	CS0PF0315Z	CC 0.1 UF 25V F	C8533	E50HU0220M	CE 22 UF 6.3V
C4011	CS0PB0215K	CC 0.1 UF 16V B	C8534	E50HU0470M	CE 47 UF 6.3V
C4014	CS0PF0315Z	CC 0.1 UF 25V F	C8535	CS0PF0315Z	CC 0.1 UF 25V F
C4015	CS0PF0315Z	CC 0.1 UF 25V F	C8536	E50HU0220M	CE 22 UF 6.3V
C4016	CS0PF0315Z	CC 0.1 UF 25V F	C8537	E50HU0220M	CE 22 UF 6.3V
C4017	E02LU0221M	CE 220 UF 6.3V	C8538	CS0PF0315Z	CC 0.1 UF 25V F
C4018	CS0PF0315Z	CC 0.1 UF 25V F	C8539	E50HU0220M	CE 22 UF 6.3V
C4019	CS0PF0315Z	CC 0.1 UF 25V F	DIODES		
C4020	E50HU0470M	CE 47 UF 6.3V	△ D502	D2WXN40050	DIODE SILICON 1N4005-EIC
C7004	E02LU0221M	CE 220 UF 6.3V	△ D503	D2WXN40050	DIODE SILICON 1N4005-EIC
C7016	E50HU0470M	CE 47 UF 6.3V	△ D504	D2WXN40050	DIODE SILICON 1N4005-EIC
C7026	CS0RB04W2K	CC 820 PF 50V B	D505	D17X001330	DIODE,SILICON 1SS133T-72
C7032	CS0RB04W2K	CC 820 PF 50V B	△ D507	D2WXN40050	DIODE SILICON 1N4005-EIC
C7035	CS0RF0415Z	CC 0.1 UF 50V F	D508	D28X10ELS6	DIODE,RECTIFIER 10ELS6-TA2B5
C7036	CS0RCH412J	CC 100 PF 50V CH	D510	D17X001330	DIODE,SILICON 1SS133T-72
C7038	E02LU2101M	CE 100 UF 16V	△ D511	D97X06R81B	DIODE,ZENER MTZJ6.8B T-72
C7039	CS0RCH4E3J	CC 0.0015UF 50V CH	△ D512	D2LKB340L0	DIODE SCHOTTKY SB340L-6737
C7040	CS0RCH4E3J	CC 0.0015UF 50V CH	D513	D97X04R71B	DIODE,ZENER MTZJ4.7B T-72
C7041	CS0RF0415Z	CC 0.1 UF 50V F	△ D514	D2WXB290S0	DIODE SILICON SB290S
C7042	CS0RCH412J	CC 100 PF 50V CH	△ D516	D28XELS2N2	DIODE RECTIFIER 10ELS2N-TA2B5
C7044	CS0RCH412J	CC 100 PF 50V CH	D518	D17X001330	DIODE,SILICON 1SS133T-72
C7052	CS0RB04Q2K	CC 470 PF 50V B	D519	D17X001330	DIODE,SILICON 1SS133T-72
C7053	CS0RB04Q2K	CC 470 PF 50V B	△ D525	D97X02001B	DIODE,ZENER MTZJ20B T-72
C7054	E50HU2220M	CE 22 UF 16 V	△ D529	D2WXB290S0	DIODE SILICON SB290S
C7055	E50HU2220M	CE 22 UF 16 V	△ D531	D28XELS2N2	DIODE RECTIFIER 10ELS2N-TA2B5

ELECTRICAL REPLACEMENT PARTS LIST

REF. NO.	PART.NO	DESCRIPTION	REF. NO.	PART.NO	DESCRIPTION
DIODES			COILS & TRANSFORMERS		
D651	D17X001330	DIODE,SILICON	1SS133T-72	△ T501	0481290739 TRANSFORMER,SWITCHING 81290739
D652	D17X001330	DIODE,SILICON	1SS133T-72	JACKS	
D653	D17X001330	DIODE,SILICON	1SS133T-72	J7001	060Q451005 RCA JACK YKC21-4156
D654	D17X001330	DIODE,SILICON	1SS133T-72	J7004	060Q401038 RCA JACK YKC21-3895
D655	D17X001330	DIODE,SILICON	1SS133T-72	J8001	063Q700004 JACK YKF51-5506
D656	D17X001330	DIODE,SILICON	1SS133T-72	SWITCHES	
D657	0021320220	LED	SLP-9118C-51H-S-T1	SW501	0530205002 SWITCH PLUS SDDFC30400
D658	D23XSB0400	DIODE SILICON	SB040-G23	SW661	0504201T32 SWITCH,TACT SKQNAED010
D1001	DD7R0S3550	DIODE SILICON	1SS355 TE-17	SW662	0504201T32 SWITCH,TACT SKQNAED010
D1002	DD7R0S3550	DIODE SILICON	1SS355 TE-17	SW663	0504201T32 SWITCH,TACT SKQNAED010
D1003	DD7R0S3550	DIODE SILICON	1SS355 TE-17	SW664	0504201T32 SWITCH,TACT SKQNAED010
D7003	D17X001330	DIODE,SILICON	1SS133T-72	SW665	0504201T32 SWITCH,TACT SKQNAED010
D7004	D17X001330	DIODE,SILICON	1SS133T-72	P.C.BOARD ASSEMBLIES	
D7007	D17X001330	DIODE,SILICON	1SS133T-72	PCB010	A2A111A010 PCB ASS'Y VMX212A
D7008	D17X001330	DIODE,SILICON	1SS133T-72	PCB030	A2A111A030E PCB ASS'Y VEX940A
D7009	D17X001330	DIODE,SILICON	1SS133T-72	PCB060	A2A111A060E PCB ASS'Y VVX300A
D7010	D17X001330	DIODE,SILICON	1SS133T-72	MISCELLANEOUS	
D7011	D23XSB0400	DIODE SILICON	SB040-G23	B502	024HT03563 CORE,BEADS W4BRH3.5X6X1.0X2
D8501	DD7R0S3550	DIODE SILICON	1SS355 TE-17	B1001	024XC36002 CORE,BEADS N2012ZP600T25
D8502	DD7R0S3550	DIODE SILICON	1SS355 TE-17	B4001	024XC36002 CORE,BEADS N2012ZP600T25
D8505	DD7R0S3550	DIODE SILICON	1SS355 TE-17	B4002	024XC36002 CORE,BEADS N2012ZP600T25
D8506	DD7R0S3550	DIODE SILICON	1SS355 TE-17	B7001	024XC31023 CORE,BEADS N2012Z102T01
D8507	DD7R0S3550	DIODE SILICON	1SS355 TE-17	B8501	024XC36002 CORE,BEADS N2012ZP600T25
D8508	DD7R0S3550	DIODE SILICON	1SS355 TE-17	B8502	024XC36002 CORE,BEADS N2012ZP600T25
ICS			RESISTOR		
△ IC501	I1KJ9A4310	IC	KIA431	△ CD501	120S655824 CORD AC BUSH 0S655824
IC502	I1KA97809A	IC	KIA7809API	CD503	06CU261503 CORD CONNECTOR CU261503
IC651	I07F529770	IC	BU2977FS	CD651	122L051101 CORD,JUMPER 2L051101
IC1001	ICQF067030	IC	ZR36703	CP501	069S320419 CONNECTOR PCB SIDE A3963WV2-3PD
IC1002	I9UJ0T6001	IC	PST6001	CP651	069J750019 CONNECTOR PCB SIDE IMSA-9604S-05Z13
IC1006	I5F04C01W	IC	BR24C01AF-WE2	CP661	069J750019 CONNECTOR PCB SIDE IMSA-9604S-05Z13
IC4001	ICQF067100	IC	MD36710X	CD4001	122S0Q0901 CORD JUMPER 2S0Q0901
IC4002	ICLJ0610DB	IC	HY57V161610DTC-8	CD4002	122S0G0901 CORD JUMPER 2S0G0901
IC7004	I0QF045800	IC	NJM4580M	CD6003	06CNBA5004 CORD,RCA PIN 06CNBA5004
IC8501	I5VF0865A0	IC	BT865AKRF	CD8501	122E080901 CORD JUMPER 2E080901
IC8503	I17F017160	IC	PCM1716E	CD8502	122F0Q1702 CORD JUMPER 2F0Q1702
IC8504	I5CF040520	IC	SN74LV4052APW	CP1001	0694290129 CONNECTOR PCB SIDE 173981-9
TRANSISTORS			CAPACITORS		
△ Q502	TAAT01273Y	TRANSISTOR SILICON	KTA1273_Y	CC.....	CERAMIC CAPACITOR
Q503	T8YJ2412K0	TRANSISTOR SILICON	2SC2412KT146 R,S	CE.....	ALUMI ELECTROLYTIC CAPACITOR
Q504	TNYJA05001	COMPOUND TRANSISTOR	DTC143EKAT146	CP.....	POLYESTER CAPACITOR
△ Q507	TCAT032034	TRANSISTOR, SILICON	KTC3203_Y-AT	CPP.....	POLYPROPYLENE CAPACITOR
Q510	T8YJ2412K0	TRANSISTOR SILICON	2SC2412KT146 R,S	CPL.....	PLASTIC CAPACITOR
△ Q511	0002E00610	PHOTO COUPLER	LTV-817M-VB	CMP.....	METAL POLYESTER CAPACITOR
Q512	T6YJ1037K0	TRANSISTOR,SILICON	2SA1037AKT146R,S	Cmpl.....	METAL PLASTIC CAPACITOR
Q513	T8YJ2412K0	TRANSISTOR SILICON	2SC2412KT146 R,S	CMPp.....	METAL POLYPROPYLENE CAPACITOR
△ Q514	TB30011430	TRANSISTOR,SILICON	2SB1143(S,T,U)	RESISTOR	
Q515	TB3T011310	TRANSISTOR SILICON	2SB1131(S,T)-AE	RC..... CARBON RESISTOR	
Q516	T8YJ2412K0	TRANSISTOR SILICON	2SC2412KT146 R,S	CAPACITORS	
△ Q517	TC3U037520	TRANSISTOR SILICON	2SC3752M/L-CB11	CC.....	CERAMIC CAPACITOR
Q520	TNYJA05001	COMPOUND TRANSISTOR	DTC143EKAT146	CE.....	ALUMI ELECTROLYTIC CAPACITOR
Q651	T6YJ1037K0	TRANSISTOR,SILICON	2SA1037AKT146R,S	CP.....	POLYESTER CAPACITOR
Q652	T8YJ2412K0	TRANSISTOR SILICON	2SC2412KT146 R,S	CPP.....	POLYPROPYLENE CAPACITOR
Q7002	T8YJ2412K0	TRANSISTOR SILICON	2SC2412KT146 R,S	CPL.....	PLASTIC CAPACITOR
Q7003	TNAAC05002	COMPOUND TRANSISTOR	KRC103RTRK	CMP.....	METAL POLYESTER CAPACITOR
Q7004	TPYJA05001	COMPOUND TRANSISTOR	DTA143EKAT146	Cmpl.....	METAL PLASTIC CAPACITOR
Q7005	T8YJ2412K0	TRANSISTOR SILICON	2SC2412KT146 R,S	CMPp.....	METAL POLYPROPYLENE CAPACITOR
Q7006	T8YJ2412K0	TRANSISTOR SILICON	2SC2412KT146 R,S	RESISTOR	
Q7007	TNYJD05001	COMPOUND TRANSISTOR	DTC144EKAT146	RC..... CARBON RESISTOR	
Q7009	T8YJ2412K0	TRANSISTOR SILICON	2SC2412KT146 R,S	CAPACITORS	
Q7010	T6YJ1037K0	TRANSISTOR,SILICON	2SA1037AKT146R,S	CC.....	CERAMIC CAPACITOR
Q8002	TAATA12660	TRANSISTOR,SILICON	KTA1266-AT(Y,GR)	CE.....	ALUMI ELECTROLYTIC CAPACITOR
Q8006	TAATA12660	TRANSISTOR,SILICON	KTA1266-AT(Y,GR)	CP.....	POLYESTER CAPACITOR
Q8501	T8YJ2412K0	TRANSISTOR SILICON	2SC2412KT146 R,S	CPP.....	POLYPROPYLENE CAPACITOR
COILS & TRANSFORMERS			RESISTOR		
△ L501	029T000086	COIL,LINE FILTER	OR4A273F20	RC..... CARBON RESISTOR	
L504	021W7A220K	COIL	22 UH	CAPACITORS	
L507	02167F220J	COIL	22 UH	CC.....	CERAMIC CAPACITOR
L7003	021JX6101K	COIL	100 UH	CE.....	ALUMI ELECTROLYTIC CAPACITOR
L7009	021JX6R27K	COIL	0.27 UH	CP.....	POLYESTER CAPACITOR
L7011	021JX6101K	COIL	100 UH	CPP.....	POLYPROPYLENE CAPACITOR
L8001	02167F220J	COIL	22 UH	CPL.....	PLASTIC CAPACITOR
L8005	021JX6R27K	COIL	0.27 UH	CMP.....	METAL POLYESTER CAPACITOR
L8006	021JX6R27K	COIL	0.27 UH	Cmpl.....	METAL PLASTIC CAPACITOR
L8501	02167B1R8K	COIL	1.8 UH	CMPp.....	METAL POLYPROPYLENE CAPACITOR
L8503	02167B1R8K	COIL	1.8 UH	RESISTOR	
L8504	02167B1R8K	COIL	1.8 UH	RC..... CARBON RESISTOR	

SPEC.NO.	M2A1-11A
O/R NO.	W162001

VIDEO AMP SCHEMATIC DIAGRAM (AV PCB)

RECORD LIST OF CHANGING			
ISSUE	DATE	O/R NO.	CONTENTS

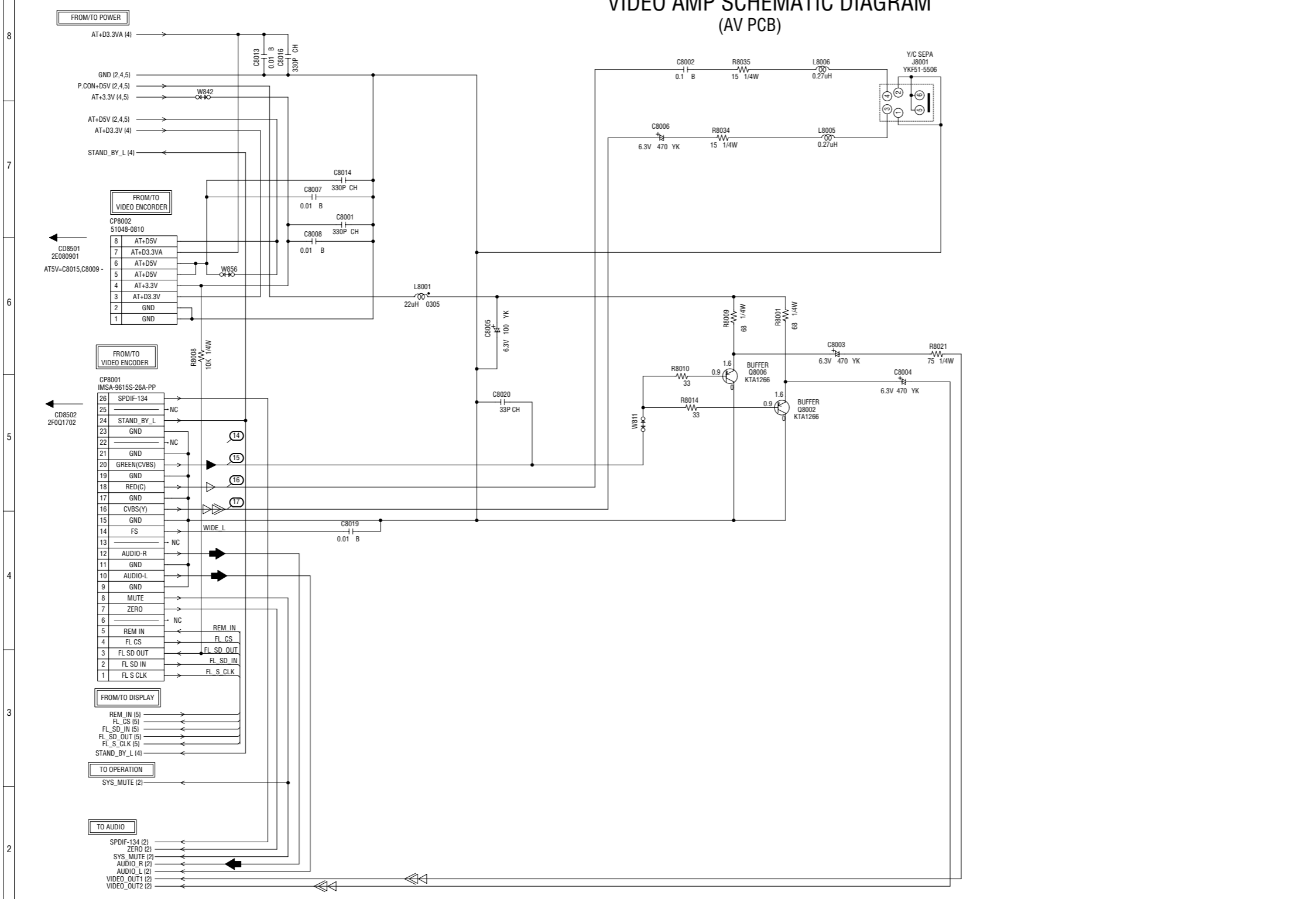

NOTE: THIS SCHEMATIC DIAGRAM IS THE LATEST AT THE TIME OF PRINTING AND SUBJECT TO CHANGE WITHOUT NOTICE.

NOTE: THE DC VOLTAGE AT EACH PART WAS MEASURED WITH THE DIGITAL TESTER DURING PLAYBACK.

- ◀ PLAYBACK LUMINANCE SIGNAL
- ◁ PLAYBACK COLOR SIGNAL
- ◂ PLAYBACK VIDEO SIGNAL
- ◄ AUDIO SIGNAL(PB)

PCB060
WX300

DET. CHKD BY	DESCRIPTION	FUNCTION	PCB NAME
K.MURATA	PAL/NTSC	VIDEO AMP	WX300A_F
CHKD BY	STANDARD	DWG. NO.	Rev. No: 5.0
W.PHON	IRAM	M2A1AVJ1	ISSU: A
DESIGN BY	MODEL	ORION ELECTRIC CO. LTD	
T.SARAWUT	M2A1-11A	SECTION: TEC-HQ	DATE: 05/02/2001
DRAWN BY	DV-C4	DISTRIBUTE:	
S.PRATJUAN		PUBRICATION: TEC-HQ SEC.	

AUDIO SCHEMATIC DIAGRAM (AV PCB)

M			
RECORD LIST OF CHANGING			
ISSUE	DATE	O/R NO.	CONTENTS

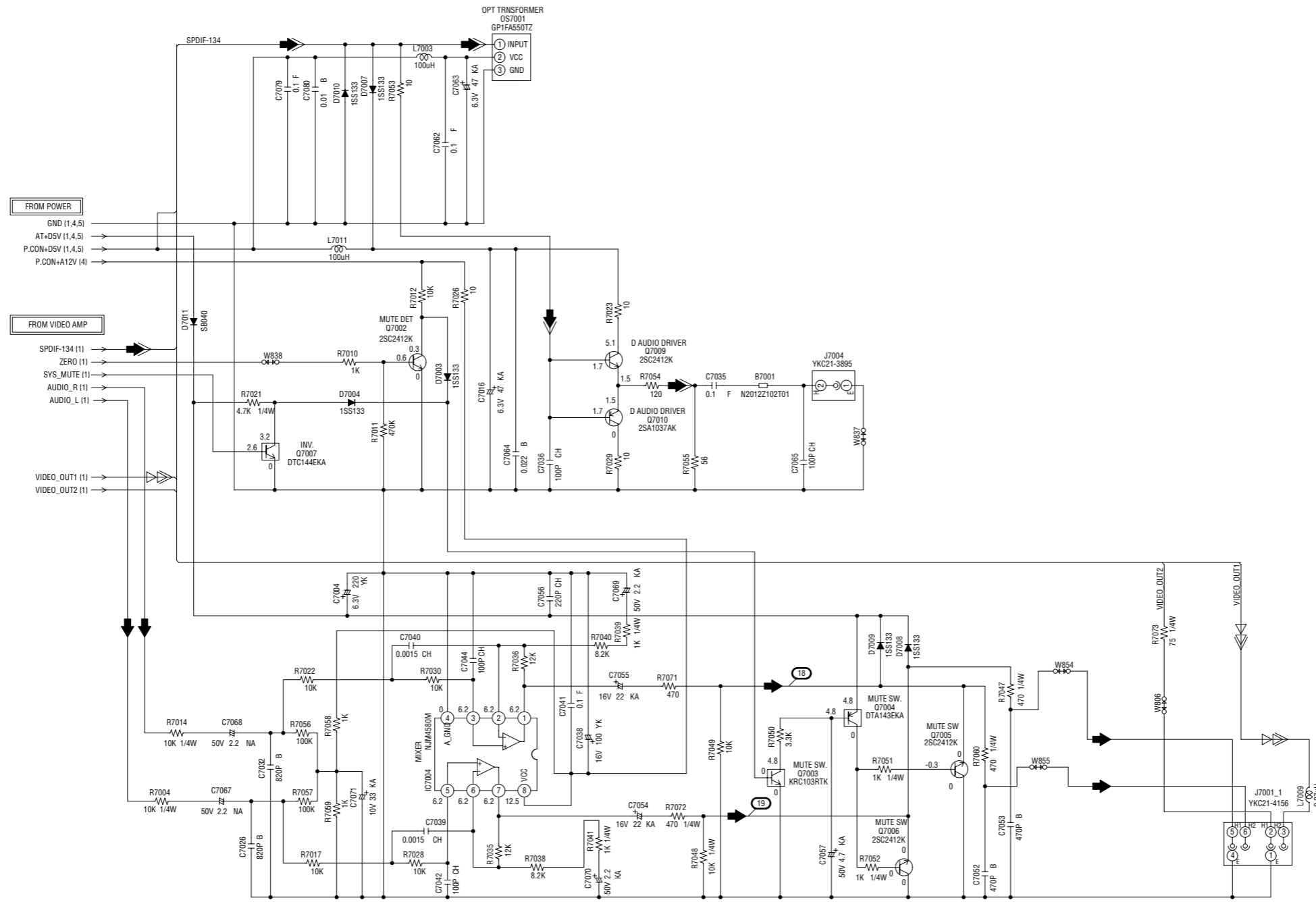

NOTE: THE DC VOLTAGE AT EACH PART WAS MEASURED WITH THE DIGITAL TESTER DURING PLAYBACK.

NOTE: THIS SCHEMATIC DIAGRAM IS THE LATEST AT THE TIME OF PRINTING AND SUBJECT TO CHANGE WITHOUT NOTICE.

AUDIO SIGNAL (PB)
 DIGITAL AUDIO SIGNAL (PB)
 PLAYBACK VIDEO SIGNAL

CAUTION: DIGITAL TRANSISTOR

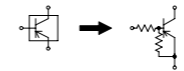

CAUTION: DIGITAL TRANSISTOR

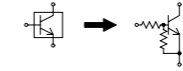

PCB060
VX300

DET. CHKD BY	DESCRIPTION	FUNCTION	PCB NAME
K.MURATA	PAL/NTSC	AUDIO	VX300A_F
CHKD BY	STANDARD	DWG. NO.	Rev. No: 5.0
W.PHON	IRAM	M2A11U1	ISSU: A
DESIGN BY	MODEL	ORION ELECTRIC CO. LTD	
T.SARAWUT	M2A1-11A	SECTION:	TEC-HQ DATE: 05/02/2001
DRAWN BY	DV-C4	DISTRIBUTE:	TEC-HQ SEC.

OPERATION/JACK SCHEMATIC DIAGRAM (AV PCB)

M			
RECORD LIST OF CHANGING			
ISSUE	DATE	O/R NO.	CONTENTS

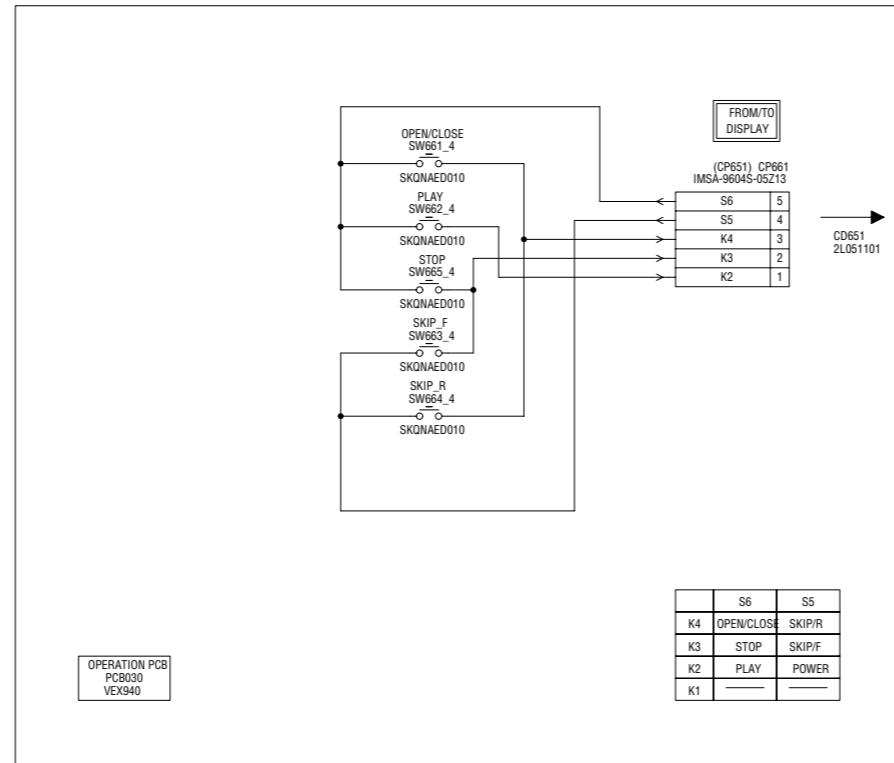

OPERATION PCB
PCB030
VEX940

NOTE: THE DC VOLTAGE AT EACH PART WAS
MEASURED WITH THE DIGITAL TESTER
DURING PLAYBACK.

NOTE: THIS SCHEMATIC DIAGRAM IS THE LATEST AT THE TIME
OF PRINTING AND SUBJECT TO CHANGE WITHOUT NOTICE.

DET. CHKD BY K.MURATA	DESCRIPTION PAL/NTSC	FUNCTION OPERATION	PCB NAME VXX300A_F
CHKD BY W.PHON	STANDARD IRAM	DWG. NO. M2A10P11	Rev. No: 5.0 ISSU : A
DESIGN BY T.SARAWUT	MODEL M2A1-11A	ORION ELECTRIC CO.LTD	
DRAWN BY S.PRATJUAN	DV-C4	SECTION: TEC-HQ	DATE: 05/02/2001
		DISTRIBUTE:	
		PUBRICATION:	TEC-HQ TSEC.

POWER SCHEMATIC DIAGRAM (AV PCB)

RECORD LIST OF CHANGING		
ISSUE	DATE	O/R NO. CONTENTS

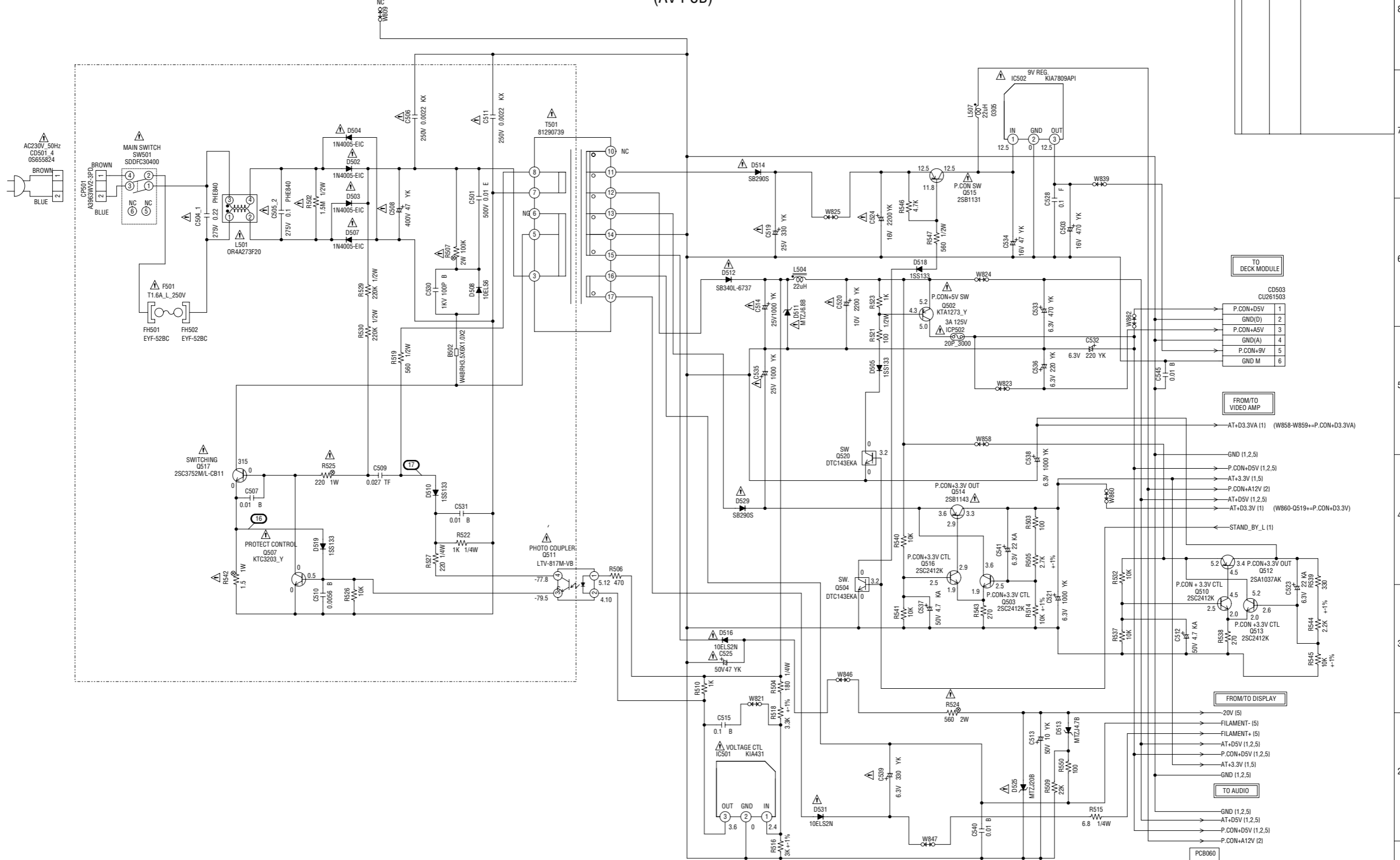

CAUTION: SINCE THESE PARTS MARKED BY ARE CRITICAL FOR SAFETY, USE ONES DESCRIBED IN PARTS LIST ONLY.

ATTENTION: LES PIÈCES RÉPARÉES PAR UN ÉTANT DANGEREUSES AN POINT DE VUE SÉCURITÉ N'UTILISER QUE CELLES DÉCRITES DANS LA NOMENCLATURE DES PIÈCES.

NOTE: THIS SCHEMATIC DIAGRAM IS THE LATEST AT THE TIME OF PRINTING AND SUBJECT TO CHANGE WITHOUT NOTICE.

NOTE: THE DC VOLTAGE AT EACH PART WAS MEASURED WITH THE DIGITAL TESTER DURING PLAYBACK.

CAUTION: DIGITAL TRANSISTOR

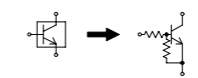

TO DECK MODULE

CD503	CU261503
P.CON+5V	1
GND(D)	2
P.CON+5V	3
GND(A)	4
P.CON+9V	5
GND M	6

FROM/TO VIDEO AMP

AT+D3.3VA (1)	(W858-W859++P.CON+D3.3VA)
GND (1, 2, 5)	
P.CON+5V (1, 2, 5)	
AT+3.3V (1, 5)	
P.CON+12V (2)	
AT+5V (1, 2, 5)	
AT+D3.3V (1)	(W860-Q519++P.CON+D3.3V)
STAND_BY_L (1)	

FROM/TO DISPLAY

-20V (5)	
FILAMENT- (5)	
FILAMENT+ (5)	
AT+5V (1, 2, 5)	
P.CON+5V (1, 2, 5)	
AT+3.3V (1, 5)	
GND (1, 2, 5)	

TO AUDIO

GND (1, 2, 5)	
AT+5V (1, 2, 5)	
P.CON+5V (1, 2, 5)	
P.CON+12V (2)	

PCB060
WX300

DET. CHKD BY	DESCRIPTION	FUNCTION	POWER	PCB NAME
K.MURATA	PAL/NTSC			VX300A_F
CHKD BY	STANDARD	DWG. NO.	Rev No: 5.0	
W. PHON		M2A1PWJ1	ISSU - A	
DESIGN BY	MODEL	ORION ELECTRIC CO. LTD		
T.SARAWUT	M2A1-11A	SECTION:	TEC-HQ	DATE: 05/02/2001
DRAWN BY	DV-C4	DISTRIBUTE:		
S.PRATUAN		PUBICATION: TEC-HQ SEC.		

DISPLAY SCHEMATIC DIAGRAM (AV PCB)

M			
RECORD LIST OF CHANGING			
ISSUE	DATE	O/R NO.	CONTENTS

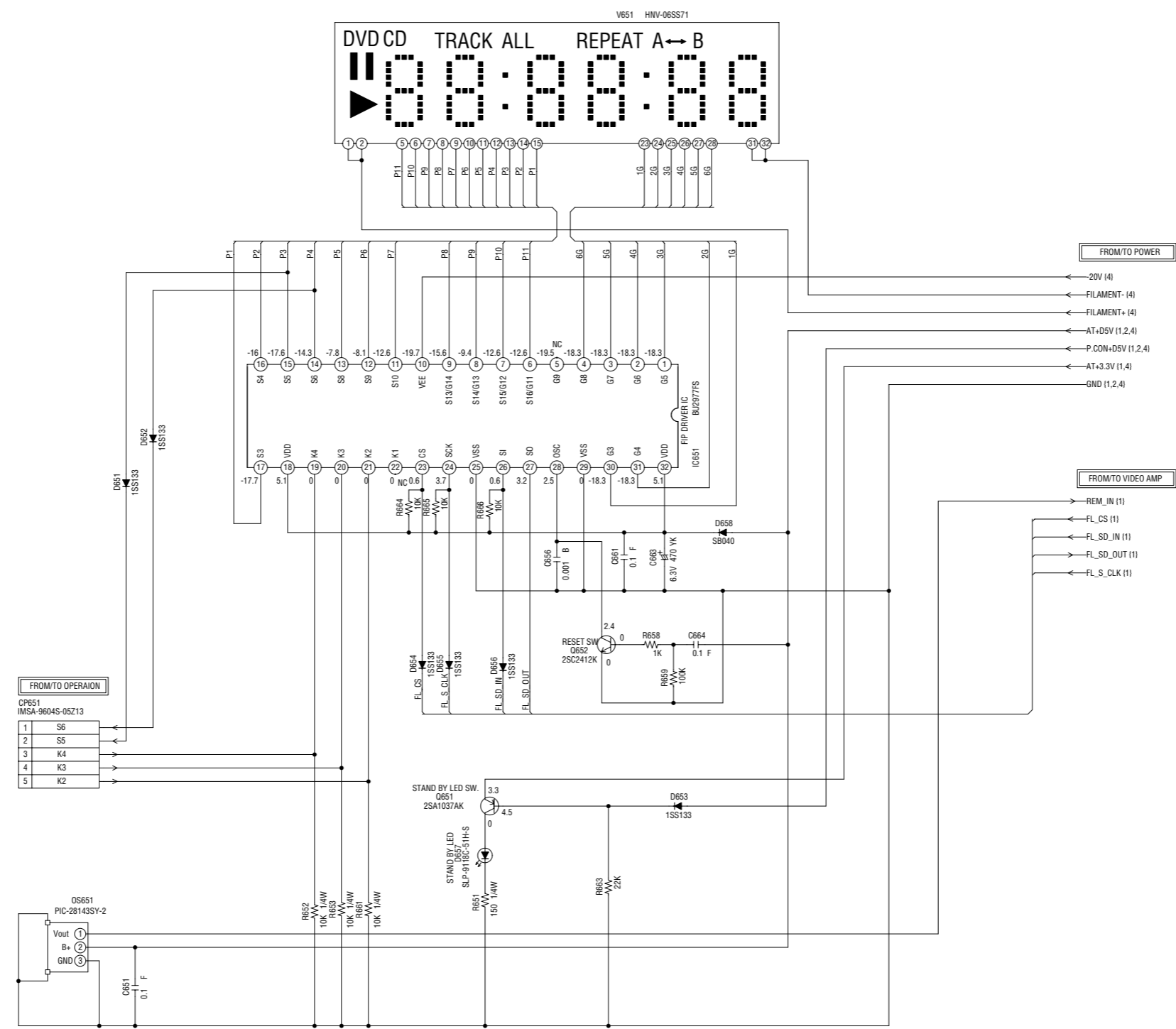

FROM/TO OPERATION	
1	S6
2	S5
3	K4
4	K3
5	K2

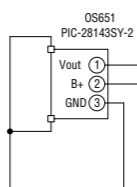

NOTE: THIS SCHEMATIC DIAGRAM IS THE LATEST AT THE TIME OF PRINTING AND SUBJECT TO CHANGE WITHOUT NOTICE.

NOTE: THE DC VOLTAGE AT EACH PART WAS MEASURED WITH THE DIGITAL TESTER DURING PLAYBACK.

PCB060
VWX300

DET. CHKD BY	DESCRIPTION	FUNCTION	DISPLAY	PCB NAME
K.MURATA	PAL/NTSC	DISPLAY		VWX300A_F
CHKD BY	STANDARD	DWG. NO.	10	Rev. No: 5.0
W.PHON	IRAM	M2A-DRJ1	10	ISSU: A
DESIGN BY	MODEL	ORION ELECTRIC CO. LTD		
T.SARAWUT	M2A1-11A	SECTION: TEC-HQ	DATE: 05/02/2001	
DRAWN BY	DV-C4	DISTRIBUTE:		
S.PRATUAN		PUBICATION: TEC-HQ SEC.		

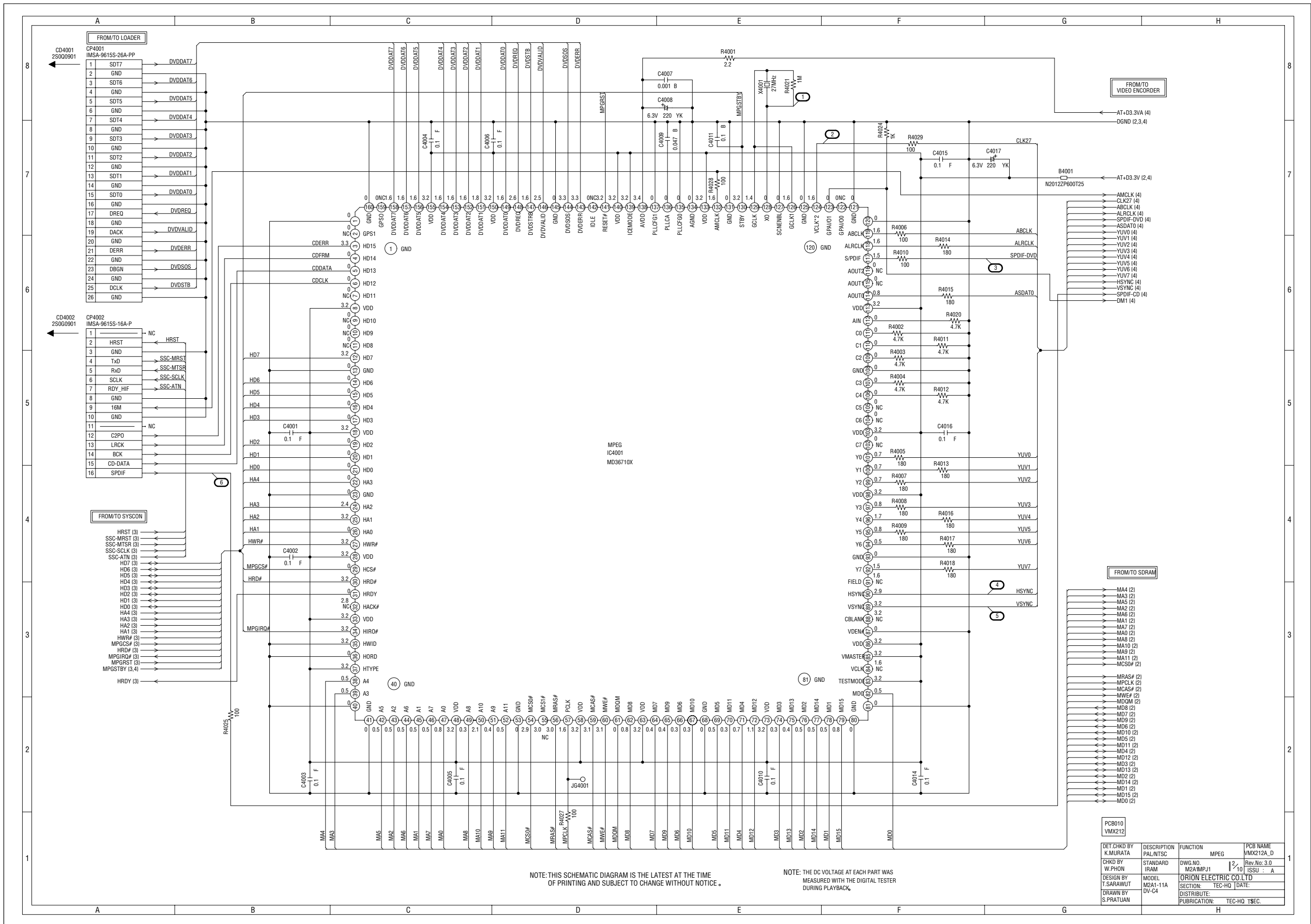

NOTE: THIS SCHEMATIC DIAGRAM IS THE LATEST AT THE TIME OF PRINTING AND SUBJECT TO CHANGE WITHOUT NOTICE.

NOTE: THE DC VOLTAGE AT EACH PART WAS MEASURED WITH THE DIGITAL TESTER DURING PLAYBACK.

PCB010 VMX212	DET. CHKD BY K. MURATA	DESCRIPTION PAL/NTSC	FUNCTION MPEG	PCB NAME VMX212A_D
	CHKD BY W. PHON	STANDARD IRAM	DWG. NO. M2AMPJ1	Rev. No. 3.0 ISSU : A
	DESIGN BY T. SARAWUT	MODEL M2A1-11A	ORION ELECTRIC CO. LTD	DATE
	DRAWN BY S. PRATUAN	DV-C4	SECTION: TEC-HQ	DISTRIBUTE: TEC-HQ TSEC.

SDRAM SCHEMATIC DIAGRAM (SYSCON PCB)

FROM/TO
MPEG

- MA4 (1) →
- MA3 (1) →
- MA5 (1) →
- MA2 (1) →
- MA6 (1) →
- MA1 (1) →
- MA7 (1) →
- MA0 (1) →
- MA8 (1) →
- MA10 (1) →
- MA9 (1) →
- MA11 (1) →
- MCS0# (1) →
- MRAS# (1) →
- MPCLK (1) →
- MCAS# (1) →
- MWE# (1) →
- MDQM (1) →
- MD5 (1) →
- MD7 (1) →
- MD9 (1) →
- MD6 (1) →
- MD10 (1) →
- MD5 (1) →
- MD11 (1) →
- MD4 (1) →
- MD12 (1) →
- MD3 (1) →
- MD13 (1) →
- MD2 (1) →
- MD1 (1) →
- MD15 (1) →
- MD0 (1) →

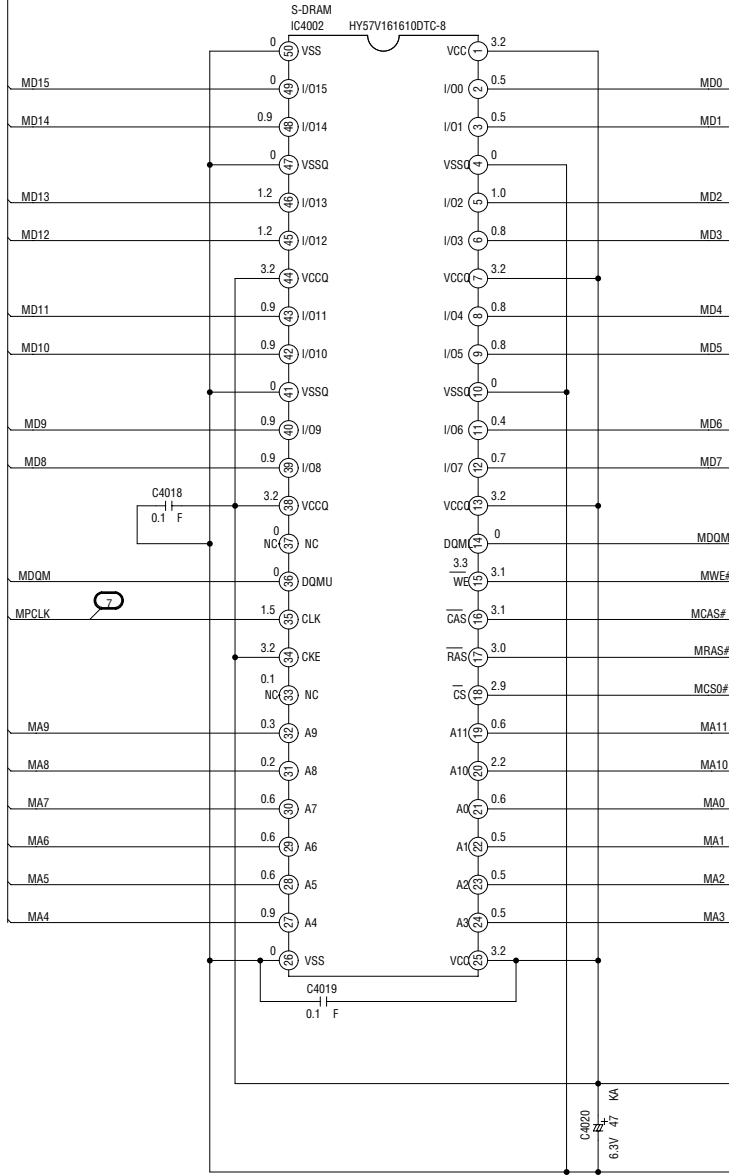

FROM VIDEO ENCODER

B4002
N2012ZP600T25

AT+D3.3V (1,4)

DGND (1,3,4)

NOTE: THIS SCHEMATIC DIAGRAM IS THE LATEST AT THE TIME OF PRINTING AND SUBJECT TO CHANGE WITHOUT NOTICE.

NOTE: THE DC VOLTAGE AT EACH PART WAS MEASURED WITH THE DIGITAL TESTER DURING PLAYBACK.

PCB010
VMX212

DET. CHKD BY	DESCRIPTION	FUNCTION	PCB NAME
K.MURATA	PALNTSC	SDRAM	VMX212A_D
CHKD BY	STANDARD	DWG. NO.	Rev. No. 3.0
W.PHON	IRAM	M2AMPJ2	ISSU : A
DESIGN BY	MODEL	ORION ELECTRIC CO. LTD	
T.SARAWUT	M2A1-11A	SECTION:	TEC-HQ DATE:
DRAWN BY	DV-C4	DISTRIBUTE:	
S.PRATUAN		PUBRICATION:	TEC-HQ 1SEC.

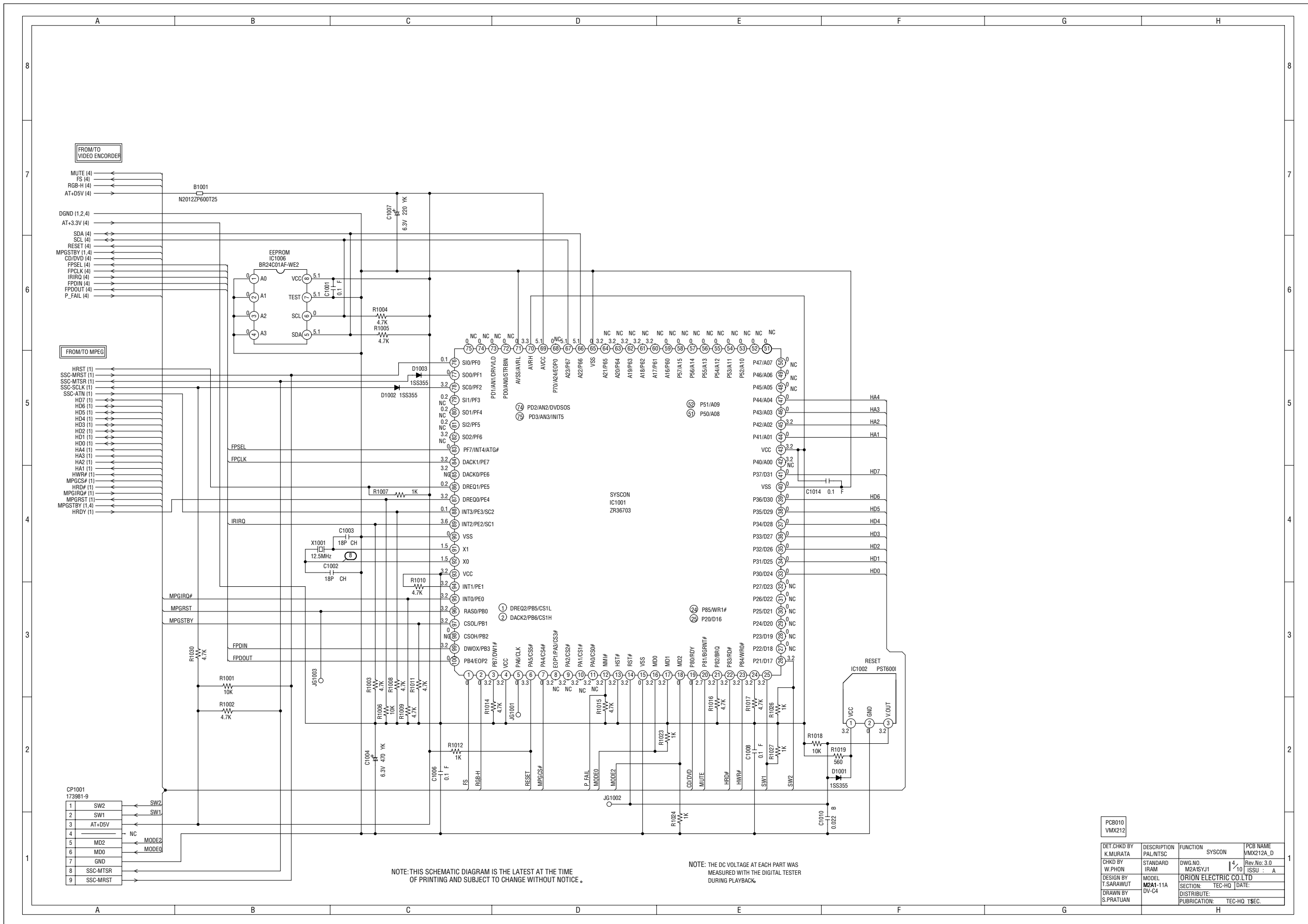

NOTE: THIS SCHEMATIC DIAGRAM IS THE LATEST AT THE TIME OF PRINTING AND SUBJECT TO CHANGE WITHOUT NOTICE.

NOTE: THE DC VOLTAGE AT EACH PART WAS MEASURED WITH THE DIGITAL TESTER DURING PLAYBACK.

PCB010 VMX212		FUNCTION SYSCON		PCB NAME VMX212A_D	
DET. CHKD BY K.MURATA	DESCRIPTION PAL/NTSC	REV. NO. M2A1SYJ1	ISSU 4	REV. NO. 3.0	ISSU : A
CHKD BY W.PHON	STANDARD IRAM	MODEL M2A1-11A	DATE	ORION ELECTRIC CO. LTD	
DESIGN BY T.SARAWUT	MODEL DV-C4	SECTION TEC-HQ	DISTRIBUTE:	DATE:	
DRAWN BY S.PRATUAN		PUBRICATION:	TEC-HQ	TSEC.	

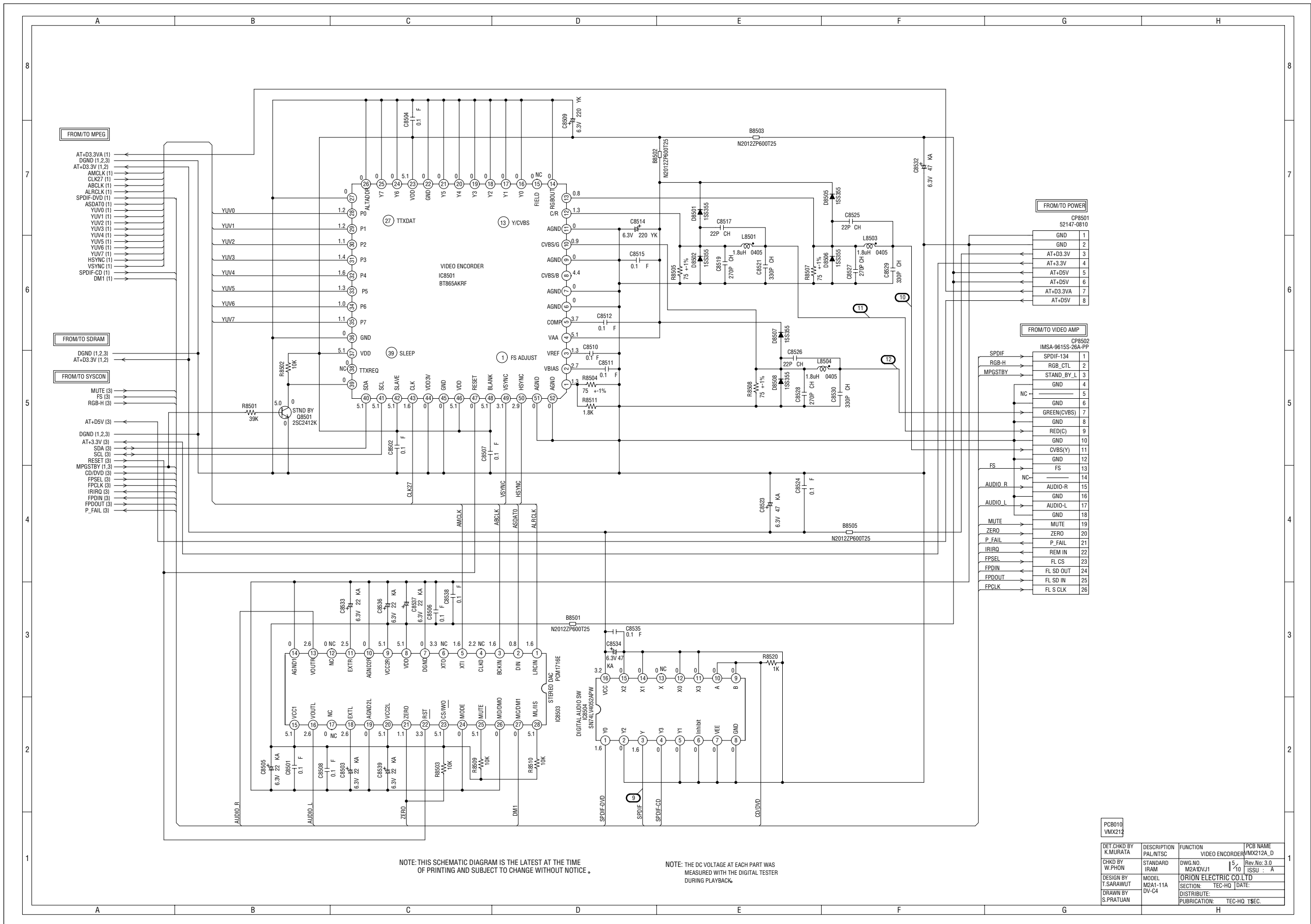

FROM/TO MPEG

FROM/TO SDRAM

FROM/TO SYSCON

FROM/TO POWER

FROM/TO VIDEO AMP

NOTE: THIS SCHEMATIC DIAGRAM IS THE LATEST AT THE TIME OF PRINTING AND SUBJECT TO CHANGE WITHOUT NOTICE.

NOTE: THE DC VOLTAGE AT EACH PART WAS MEASURED WITH THE DIGITAL TESTER DURING PLAYBACK.

PCB010
VMX212

DET. CHKD BY	DESCRIPTION	FUNCTION	PCB NAME
K.MURATA	PAL/NTSC	VIDEO ENCODER	VMX212A_D
CHKD BY	STANDARD	DWG. NO.	Rev. No. 3.0
W.PHON	IRAM	M2A1DVJ1	ISSU : A
DESIGN BY	MODEL	M2A1-11A	ORION ELECTRIC CO. LTD
T.SARAWUT	DV-C4		SECTION: TEC-HQ DATE:
DRAWN BY			DISTRIBUTE:
S.PRATUAN			PUBRICATION: TEC-HQ TSEC.

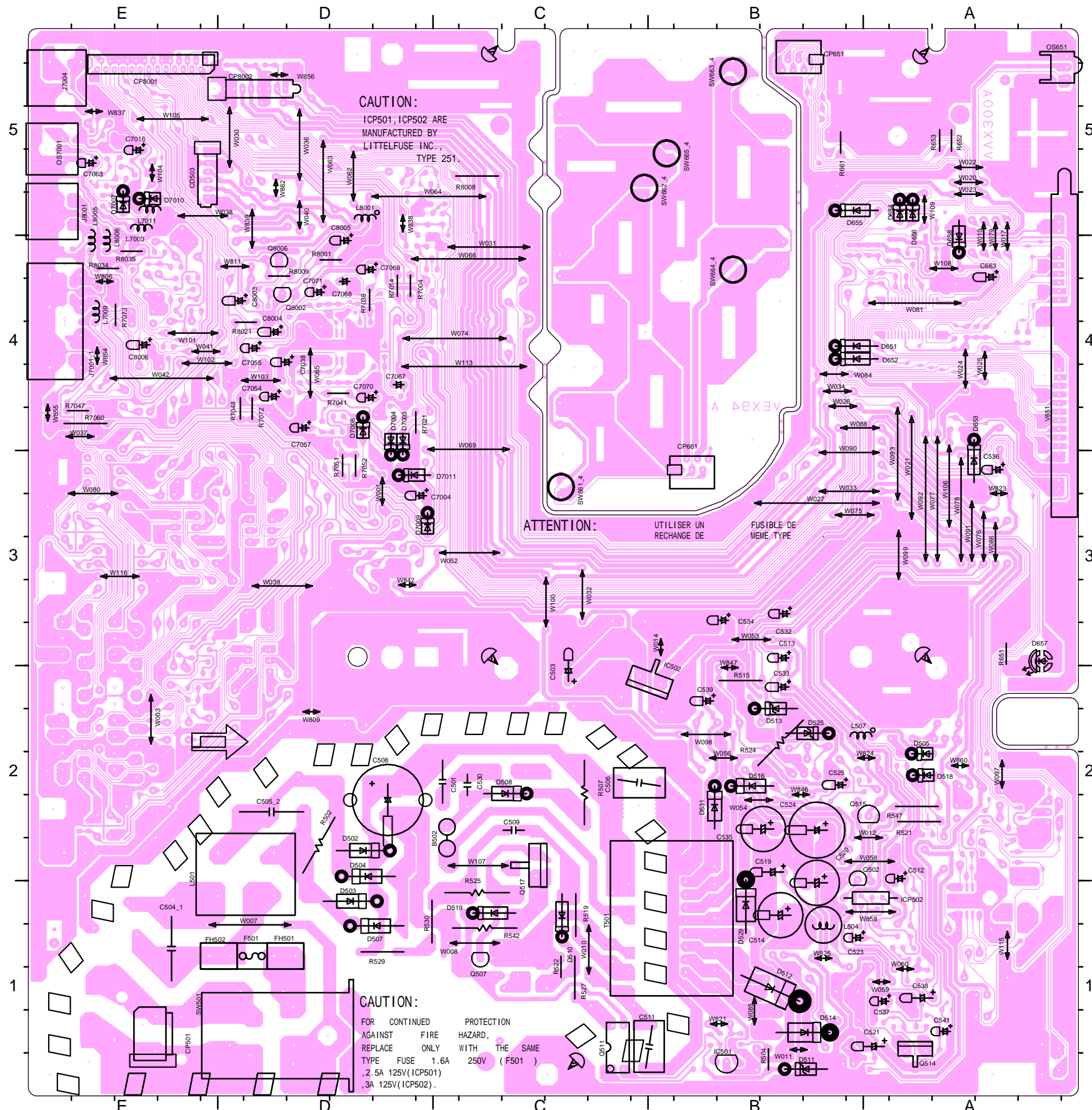

- CD503
1. P.CON+DSV
 2. GND(D)
 3. P.CON+ASV
 4. GND(A)
 5. P.CON+9V
 6. GND M
- CP651
1. S6
 2. S5
 3. K4
 4. K3
 5. K2
- CP661
1. K2
 2. K3
 3. K4
 4. S5
 5. S6
- CP8001
1. FL S CLK
 2. FL SD IN
 3. FL SD OUT
 4. FL CS
 5. REM IN
 6. P FAIL
 7. ZERO
 8. MUTE
 9. GND
 10. AUDIO_L
 11. GND
 12. AUDIO_R
 13. GND
 14. FS
 15. GND
 16. CVBS(Y)
 17. GND
 18. RED(C)
 19. GND
 20. GREEN(CVBS)
 21. GND
 22. BLUE(CVBS)
 23. GND
 24. STAND_BY_L
 25. RGB_CTL
 26. SPDIF_134
- CP8002
1. GND
 2. GND
 3. AT+D3.3V
 4. AT+3.3V
 5. AT+DSV
 6. AT+DSV
 7. AT+D3.3VA
 8. AT+DSV

DIAMETER	SILK	SU	TWSS	
1.6 mm		KS	MS5	MA
2.0 mm		KA	MS7	SR
		KALL	MS7-L	
		NP	NW	
		KANP	NW7	
		KSNP	NW5	
		VS		WX
		VAN		WP

IN CHARGE		MODEL CODE	NAME	DATE
A.PREECHA		M2A1-11A	AV_MT_PCB	2001 MAY 01
DRAWN BY		DWG. NO.	ISSUE	
J.SIRIYAN		DV-C4	D0	
SYSTEM		RV	ORIONELECTRIC CO.,LTD.	Rev.No. 5
NTSC			SEC.	PRO-ENG
APPROVE	CHECK	VOLT	SAMPLE	
K.MAKARA	T.BASAKI	CRC	P.LIST	

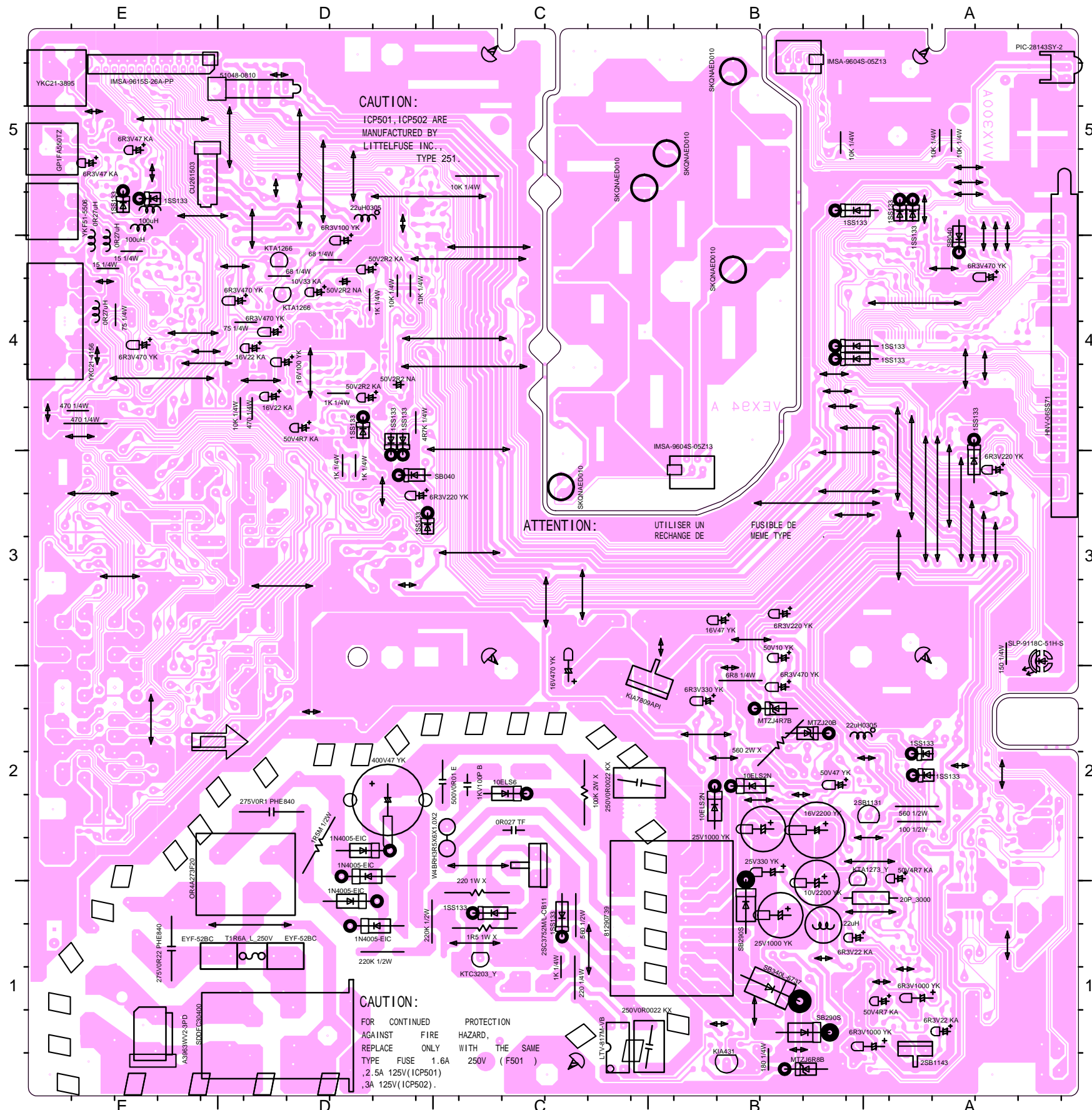

- CD503
1. P.CON+DSV
 2. GND(D)
 3. P.CON+ASV
 4. GND(A)
 5. P.CON+SV
 6. GND M

- CP651
1. S6
 2. S5
 3. K4
 4. K3
 5. K2

- CP661
1. K2
 2. K3
 3. K4
 4. S5
 5. S6

- CP8001
1. FL SD CLK
 2. FL SD IN
 3. FL SD OUT
 4. FL CS
 5. REM IN
 6. P FAIL
 7. ZERO
 8. MUTE
 9. GND
 10. AUDIO_L
 11. GND
 12. AUDIO_R
 13. GND

- CP8002
1. GND
 2. GND
 3. AT+D3.3V
 4. AT+3.3V
 5. AT+DSV
 6. AT+D5V
 7. AT+D3.3VA
 8. AT+D5V

SU	TWSS	
KS	MS5	MA
KA	MS7	SR
KALL	MS7-L	
NP	NW	
KANP	NW7	
KSNP	NW5	
VS		WX
VAN		WP

DIAMETER	SILK
1.6 mm	
2.0 mm	

IN CHARGE		DATE: 2001 MAY 03	
A.PREECHA	MODEL CODE: M2A1-11A	NAME: AV_MT_PCB	VVX300A
DRAWN BY: J.SIRIVAN	DV-C4 DVD4	DWG. NO.:	ISSUE: 00
SYSTEM: NTSC	RV	ORIONELECTRIC CO.,LTD.	Rev. No.: 5
APPROVE: K.MAKARA	CHECK: T.BASAKI	SEC.:	PRO-ENG: 2001 MAY 03
		VOLT: 01..	SAMPLE: 01..
		CRC: 01..	P.LIST: 01..

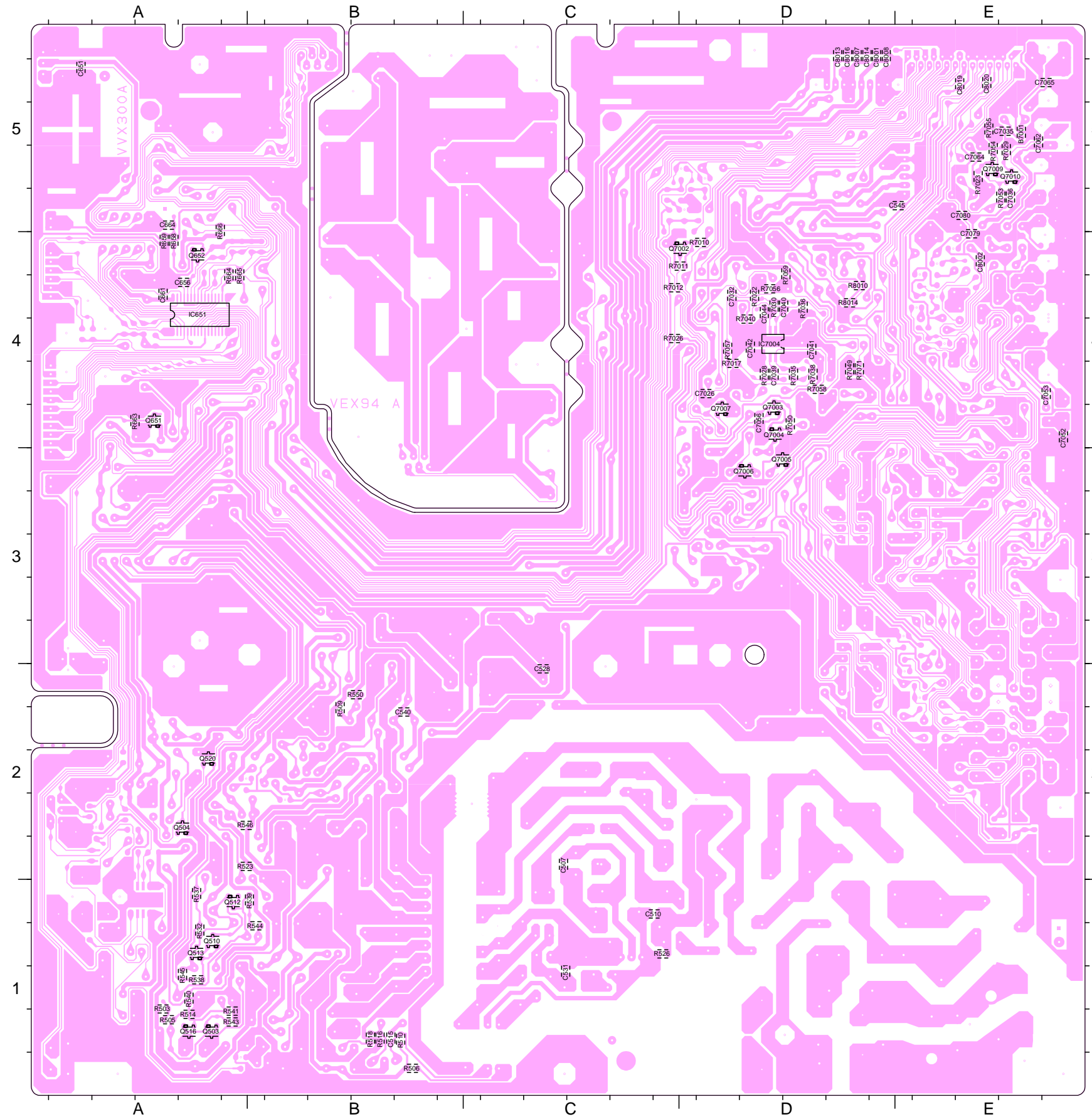

CHIP TRANSISTOR & DIODE

PARTS CODE	INDICATION
2SC3734	B23,B24
2SC2412K	BR,BS
2SA1037K	FR,FS
DTC124EK	25
DTA124EK	15
DTC114EK	24
DTA114EK	14
DTC143EK	23
DTA143EK	13
DTC144TKA	06
DTC114TKA	04
DA204K	K

VALUE (32-16)	CHIP MELF
0R0012 u F ~ 0R0068 u F	B → X
0R0082 u F ~ 0R01 u F	B → Y

IN CHARGE		MODEL CODE		NAME		DATE
A.PREECHA	M2A1-11A	AV_MT_PCB	VVX300A			2001.MAY.03
J.SIRINAH	DV-C4	DWG.NO.	0-AV-1000 B	ISSUE	00	
SYSTEM	RV	ORIONELECTRIC CO.,LTD.		Rev No.	5	
NTSC		SEC.	PRO.ENG	2001.MAY.03		
APPROVE	CHECK	ICLT.	DT.	SAMPLE	DT.	
K.MAKARA	T.SASAKI	CIRC.	DT.	P LIST	DT.	

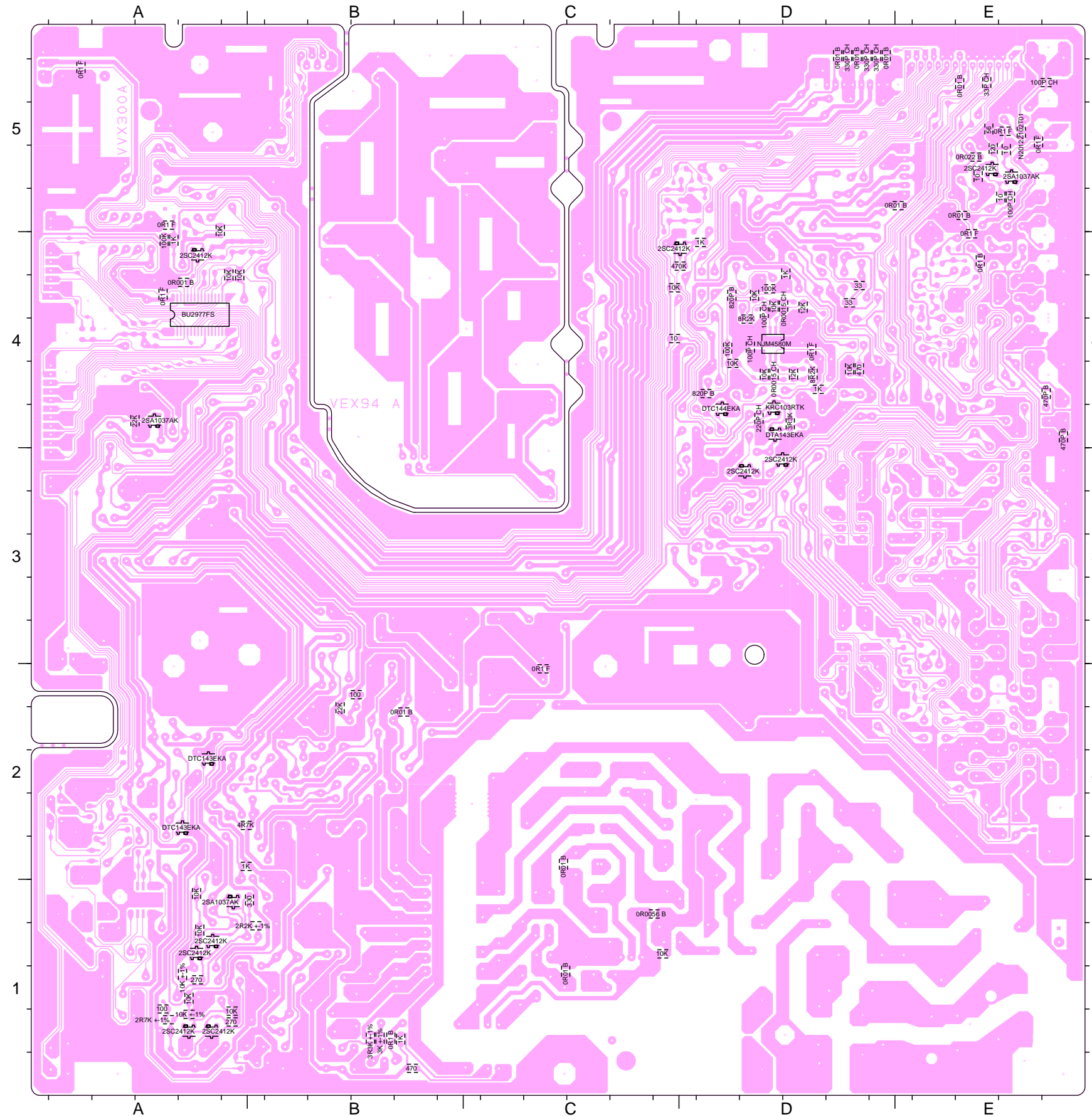

CHIP TRANSISTOR & DIODE

PARTS CODE	INDICATION
2SC3734	B23,B24
2SC2412K	BR,BS
2SA1037K	FR,FS
DTC124EK	25
DTA124EK	15
DTC114EK	24
DTA114EK	14
DTC143EK	23
DTA143EK	13
DTC144TKA	06
DTC114TKA	04
DA204K	K

VALUE (32-16)	CHIP MELF
0R0012 uF ~ 0R0068 uF	B → X
0R0082 uF ~ 0R01 uF	B → Y

IN CHARGE		MODEL CODE		NAME		DATE
A.PREECHA	M2A1-11A	AV_MT_PCB	VVX300A			2001.MAY.03
J.SIRINAH	DV-C4	DWG.NO.	0-AV-1000 B	ISSUE	00	
SYSTEM	NTSC	ORIONELECTRIC CO.LTD.		Rev No.	5	
APPROVE	CHECK	COLT.	SEC.	PRO.ENG	2001.MAY.03	
K.MAKARA	T.SASAKI	DR.		SAMPLE	DR.	
		CIRC.		P.LIST	DR.	

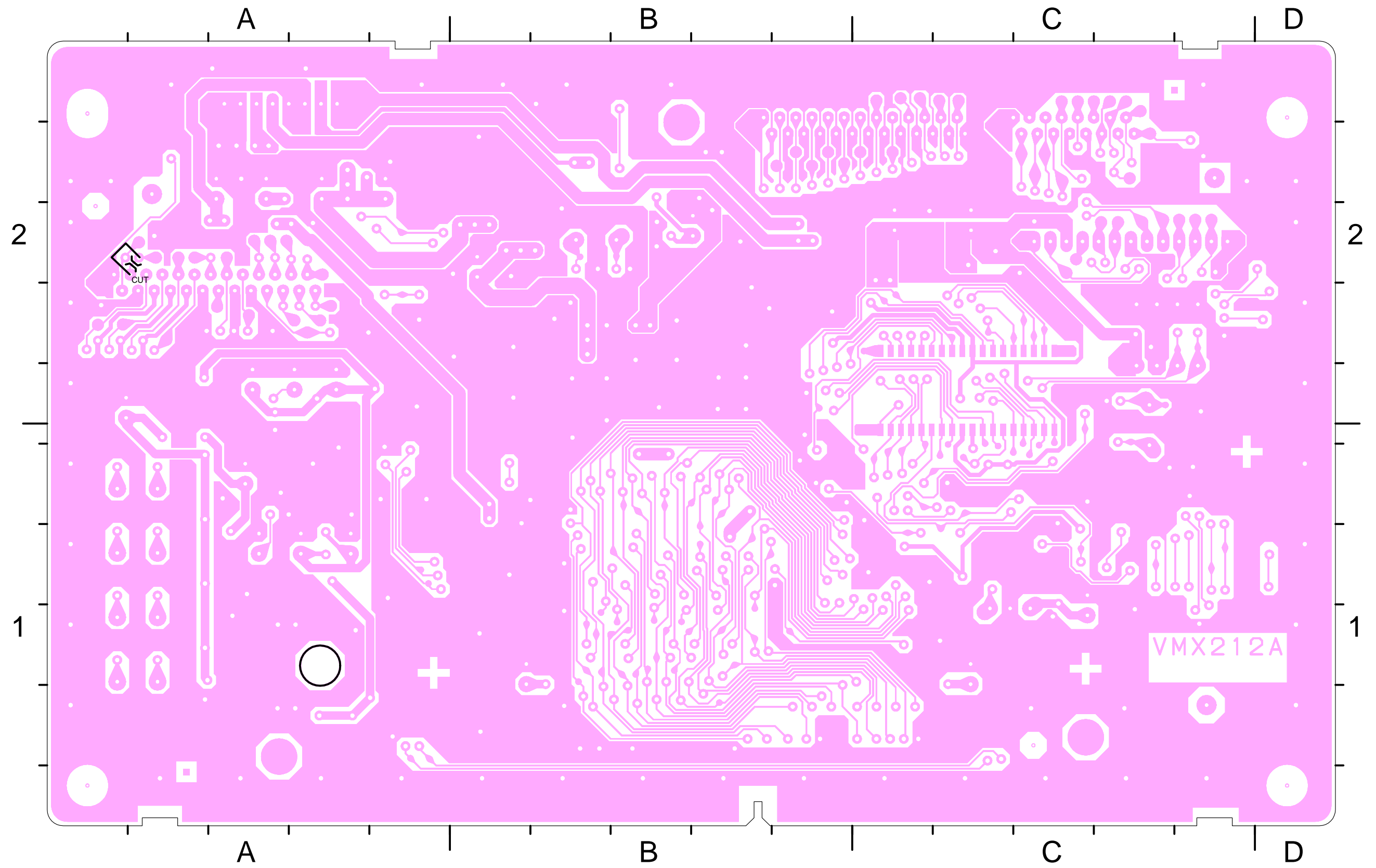

IMPORTANT WARNING

CAUTION:

DVD PLAYER IS A CLASS 1 LASER PRODUCT. HOWEVER THIS PLAYER USES A VISIBLE LASER BEAM WHICH COULD CAUSE HAZARDOUS RADIATION EXPOSURE IF DIRECTED. BE SURE TO OPERATE THE PLAYER CORRECTLY AS INSTRUCTED.

THE FOLLOWING CAUTION LABEL IS LOCATED ON THE REAR PANEL OF THE PLAYER.

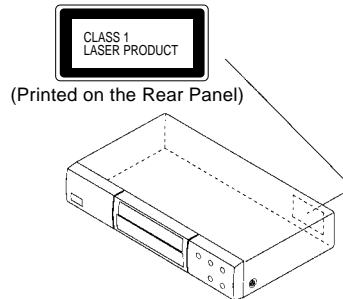

WHEN THIS PLAYER IS PLUGGED TO THE WALL OUTLET, DO NOT PLACE YOUR EYES CLOSE TO THE OPENING OF THE DISC TRAY AND OTHER OPENINGS TO LOOK INTO THE INSIDE OF THIS PLAYER.

USE OF CONTROLS OR ADJUSTMENTS OR PERFORMANCE OF PROCEDURES OTHER THAN THOSE SPECIFIED HEREIN MAY RESULT IN HAZARDOUS RADIATION EXPOSURE.

DO NOT OPEN COVERS AND DO NOT REPAIR YOURSELF. REFER SERVICING TO QUALIFIED PERSONNEL.

SERVICING NOTICES ON CHECKING

1. KEEP THE NOTICES

As for the places which need special attentions, they are indicated with the labels or seals on the cabinet, chassis and parts. Make sure to keep the indications and notices in the operation manual.

2. USE THE DESIGNATED PARTS

The parts in this equipment have the specific characters of incombustibility and withstand voltage for safety. Therefore, the part which is replaced should be used the part which has the same character.

Especially as to the important parts for safety which is indicated in the circuit diagram or the table of parts as a  mark, the designated parts must be used.

3. PUT PARTS AND WIRES IN THE ORIGINAL POSITION AFTER ASSEMBLING OR WIRING

There are parts which use the insulation material such as a tube or tape for safety, or which are assembled in the condition that these do not contact with the printed board. The inside wiring is designed not to get closer to the pyrogenic parts and high voltage parts. Therefore, put these parts in the original positions.

4. PERFORM A SAFETY CHECK AFTER SERVICING

Confirm that the screws, parts and wiring which were removed in order to service are put in the original positions, or whether there are the portions which are deteriorated around the serviced places serviced or not. Check the insulation between the antenna terminal or external metal and the AC cord plug blades. And be sure the safety of that.

TABLE OF CONTENTS

IMPORTANT WARNING	A1-1
SERVICING NOTICES ON CHECKING	A1-1
TABLE OF CONTENTS	A2-1
PARENTAL CONTROL-RATING LEVEL	A2-1
GENERAL SPECIFICATIONS	A3-1~A3-3
DISASSEMBLY INSTRUCTIONS	
1.REMOVAL OF MECHANICAL PARTS AND P.C. BOARDS	B1-1
2.REMOVAL AND INSTALLATION OF FLAT PACKAGE IC	B2-1, B2-2
PRINTED CIRCUIT BOARDS	
SYSCON	C-1, C-2
AV/OPERATION	C-3~C-6
BLOCK DIAGRAMS	
DVD	D-1, D-2
POWER	D-3, D-4
SCHEMATIC DIAGRAMS	
MPEG	E-1, E-2
SDRAM	E-3, E-4
SYSCON	E-5, E-6
VIDEO ENCODER	E-7, E-8
VIDEO AMP	E-9, E-10
AUDIO	E-11, E-12
OPERATION	E-13, E-14
POWER	E-15, E-16
DISPLAY	E-17, E-18
INTERCONNECTION DIAGRAM	E-19, E-20
WAVEFORMS	F-1, F-2
MECHANICAL EXPLODED VIEW	G-1
MECHANICAL REPLACEMENT PARTS LIST	H1-1
ELECTRICAL REPLACEMENT PARTS LIST	H2-1~H2-3

PARENTAL CONTROL - RATING LEVEL **4 DIGIT PASSWORD CANCELLATION**

If the stored 4 digit password in the Rating Level menu needs to be cancelled, please follow the steps below.

1. Turn Unit ON.
2. Press and hold the 'STOP' key on the front panel.
3. Simultaneously press and hold the '7' key on the remote control unit.
4. Hold both keys for more than 3 seconds.
5. The On Screen Display message 'INITIALIZED' will appear.
6. The 4 digit password has now been cleared.

NB: The above procedure will reset ALL of the player's settings to the default factory state.

GENERAL SPECIFICATIONS

G-1	Outline of the product		DVD VIDEO PLAYER				
G-2	DVD System	Color System	PAL/ NTSC				
		Disc	DVD, CD-DA				
		Disc Diameter	120 mm , 80 mm				
		Deck	Disc Loading System				
			Motor				
		Pick up	1-Lens 2-Beams System				
		Playback time (Max)	DVD 1-Layer	135min (4.7GB)			
			DVD 2-Layer	245min (8.5GB)			
			CD	74min			
			VIDEO CD	--min			
		Search speed	Actual	Fwd	2-20 times		
				Rev	2-20 times		
Slow speed	Actual	Fwd	1/7-1/2 times				
		Rev	1/7 -1/2 times				
	Actual		2-45 times				
			2-45 times				
	Actual		--				
			1-2 times				
G-3	Power	Power Source	AC 220- 50Hz				
			DC -				
		Power Consumption	13 W				
			3 W				
G-4	Signal	Video Signal	Output Level	1 V p-p/75 ohm			
			S/N Ratio (Weighted)	65 dB			
			Horizontal Resolution at DVD	500 Lines			
		RGB Signal	Output Level	---			
			Audio Signal	Input Level Microphone	-- dB/ -- ohm		
			Output Level Line	-6 dB/ 1k ohm (0dB=0.775Vrms)			
			S/N Ratio at (Weighted)	90dB			
			Harmonic Distortion :	0.01% (1KHz)			
			Frequency Response :	at DVD	4 Hz - 22 KHz		
				at VIDEO CD	--		
				at CD	4 Hz - 20 KHz		
		G-5	Interface	Switch	Front	Power	No
Play	Yes						
Open/Close	Yes						
Skip(>>)	Yes						
Skip(<<)	Yes						
Still/Pause	No						
Stop	Yes						
Shuttle(Search/REV/FWD)	No						
Main Power SW	Yes						
Rear	Attenuator				No		
	Video/RGB Selector				No		
	Volume				Phones Volume	No	
					Mic Volume	No	
					Echo Volume	No	
					Rec/OTR	No	
	Indicator				LED	Power	No
						Stand By	Yes
					Rec/Pause	No	
Repeat				No			
Disc				No			
Play				No			
Still				No			
Surround				No			
Level Meter				No			
Fluorescent Indicator				DVD	Yes		
	Pause			Yes			
	Track			Yes			
	A			Yes			
	-B			Yes			
	VIDEO			No			
	CD			Yes			
	Play			Yes			
	ALL			Yes			
	PROG			No			
Mic Mark	No						
Title	No						
Repeat	Yes						
PBC	No						
Angle	No						
Chapter	No						

GENERAL SPECIFICATIONS

		Music Calender(1-14,Play) 7-seg Digit(6)	No Yes
	Terminals	Front	No
		Rear	Video Output RCA x 2
		S-Video Output	S-Jack x 1
		Audio Output	RCA x 2(Stereo)
		Euro Scart	No
		Digital Audio Output	Coaxial, Optical
		AC Inlet	No
G-6	Set Size	Approx. W x D x H (mm)	430.0 x 258.5 x 80.0
G-7	Weight	Net (Approx.)	2.7 kg(6.0 lbs)
		Gross (Approx.)	3.7 kg(8.2 lbs)
G-8	Regulation	Safety	IRAM
		Radiation	NONE
G-9	Temperature	Operation	5C - 40C
		Storage	-20C - 60C
G-10	Operating Humidity		Less than 80% RH
G-11	On Screen Display	Menu	Yes
		Menu Type	Character
		Rating Level	Yes
		Audio	Yes
		Sub Title	Yes
		TV Screen Size	Yes
		OSD Display On/Off	Yes
		Menu Language	Yes
		Audio Output	No
		Video Output RGB/Composite	No
		Set Up Language	Yes
		Password Lock/Unlock	Yes
		Open	Yes
		Close	Yes
		No disc	Yes
		Reading	Yes
		Play	Yes
		Still/Pause	Yes
		Stop	Yes
		Prohibit Mark	Yes
		Step	Yes
		Next	Yes
		Back	Yes
		Random	Yes (CD ONLY)
		Repeat	Yes
		Slow+	Yes
		Slow-	Yes
		Search+	Yes
		Search-	Yes
		Jump	Yes
		Resume	Yes
		Title No.	Yes
		Chapter No.	Yes
		Track No.	Yes
		Time	Yes
		Sub Title No.	Yes
		Angle No.	Yes
		Vocal On/Off	Yes
		Audio No.	Yes
		Audio Stereo L/R	No
		Zoom	Yes
		Marker No.	Yes
		Program Play Back	Yes (CD ONLY)
G-12	OSD Language		Eng Fre Spa Ger Ita
G-13	Remote Control	Unit	RC- EJ
		Glow in Dark Remocon	No
		Format	NEC
		Custom Code	71-8E h
		Power Source	Voltage(D.C) 3V
			UM size x pcs UM-4 x 2 pcs
		Total Keys	40 Key
		Keys	Power Yes
			DISPLAY Yes
			OPEN/CLOSE Yes
			1 Yes
			2 Yes
			3 Yes
			4 Yes
			5 Yes
			6 Yes

GENERAL SPECIFICATIONS

		7	Yes
		8	Yes
		9	Yes
		0	Yes
		CLEAR	Yes
		PLAY	Yes
		STOP	Yes
		PAUSE/STILL	Yes
		<<(SKIP)	Yes
		>> (SKIP)	Yes
		<<(SEARCH)	Yes
		>>(SEARCH)	Yes
		SLOW--	Yes
		SLOW+	Yes
		MENU	Yes
		TITLE	Yes
		SET UP	Yes
		RETURN	Yes
		SELECT/ENTER	Yes
		UP	Yes
		DOWN	Yes
		RIGHT	Yes
		LEFT	Yes
		AUDIO	Yes
		ANGLE	Yes
		SUB TITLE	Yes
		ON/OFF(SUB TITLE)	No
		PLAY MODE	Yes
		Zoom	Yes
		MARKER	Yes
		REPEAT(A-B)	Yes
		REPEAT(MODE)	No
		SEARCH MODE(JUMP)	Yes
		Mic On/Off	No
G-14	Features	Auto Power Off	No
		Parental Lock	Yes
		Echo	No
		Mic Mixing	No
		Digital Out (AC-3,PCM,DTS)	Yes
		Down Mix Out (AC-3,PCM,DTS)	Yes
		Self Diagnostic	No
G-15	Accessories	Owner's Manual Language w/Guarantee Card	Spa Yes
		Remote Control Unit	Yes
		Guarantee Card	No
		Warning Sheet	No
		Service Station List	No
		Important Tag	No
		AC Plug Adapter	No
		Quick Set-up Sheet	No
		Battery	Yes
		UM size x pcs	UM-4 x 2 pcs
		OEM Brand	No
		AC Cord	No
		AV Cord	Yes
		S-Video Cable	No
		21pin cable	No
		800 No Sticker	No
		Toll Free Insert Sheet	No
		Safety Tip	No
		Warranty Card	Yes
		Rating Sheet	Yes
G-16	Carton	Master Carton	No
		Content	--- Sets
		Material	--- / ---
		Dimensions W x D x H(mm)	---
		Description of Origin	---
		Gift Box	Yes
		Material	Single/Full Color
		W/Color Photo Label	Yes
		Dimensions W x D x H(mm)	515 x 371 x 180
		Design	As Per BUYER 's
		Description of Origin	Yes
		Drop Test	---
		Height (cm)	---
		Container Stuffing	---
G-17	Cabinet Material	Cabinet Front	PS 94HB

DISASSEMBLY INSTRUCTIONS

1. REMOVAL OF MECHANICAL PARTS AND P.C. BOARDS

CAUTION: BEFORE ATTEMPTING TO REMOVE OR REPAIR ANY PCB, UNPLUG THE POWER CORD FROM THE AC SOURCE.

1-1: TOP CABINET AND FRONT TRAY PLATE (Refer to Fig. 1-1)

1. Turn on the power supply to stand by for the eject.
2. Unlock the 2 supports ①.
3. Remove the Front Tray Plate in the direction of arrow (A).
4. Remove the 5 screws ②.
5. Remove the Top Cabinet in the direction of arrow (B).

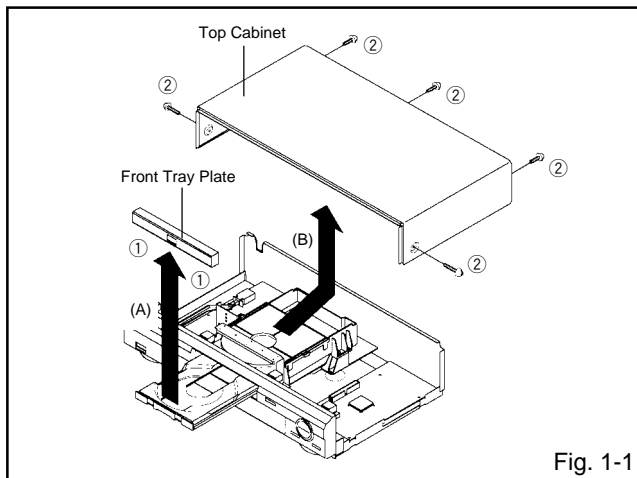

Fig. 1-1

1-2: FRONT CABINET AND OPERATION PCB (Refer to Fig. 1-2)

1. Unlock the 3 supports ①.
2. Disconnect the following connector: (CP651).
3. Remove the Front Cabinet in the direction of arrow (A).
4. Remove the 3 screws ② and remove the Operation PCB.

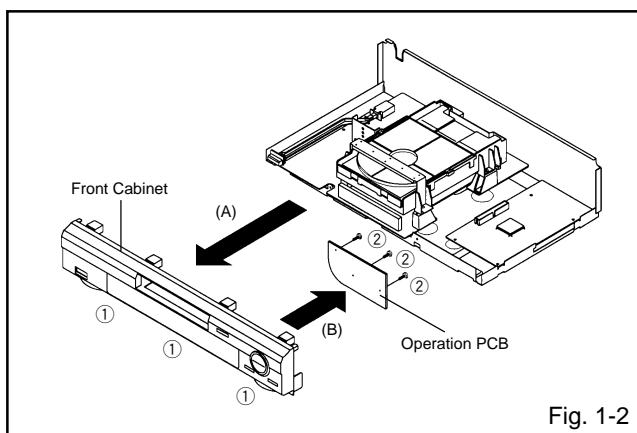

Fig. 1-2

1-3: DECK CHASSIS (Refer to Fig. 1-3)

1. Remove the 4 screws ①.
2. Disconnect the following connectors: (CP4001, CP4002 and CD503).
3. Remove the Deck Chassis in the direction of arrow.

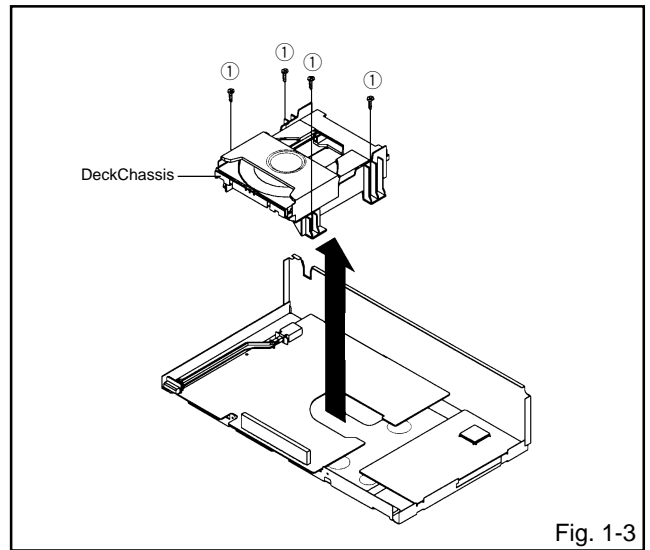

Fig. 1-3

1-4: SYSCON PCB (Refer to Fig. 1-4)

1. Remove the 4 screws ①.
2. Disconnect the following connectors: (CP8501 and CP8502).
3. Remove the Syscon PCB in the direction of arrow.

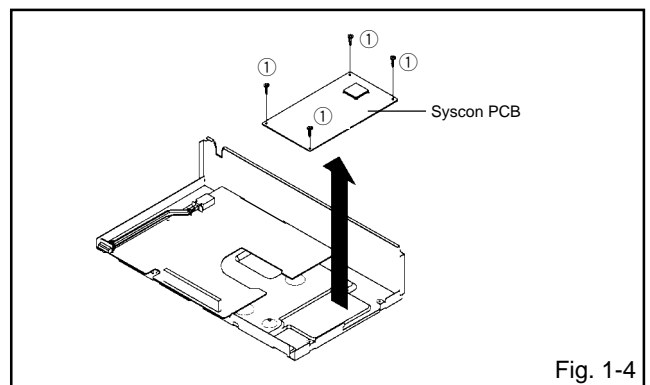

Fig. 1-4

1-5: AV PCB (Refer to Fig. 1-5)

1. Remove the 4 screws ①.
2. Remove the screw ②.
3. Remove the AV PCB in the direction of arrow.

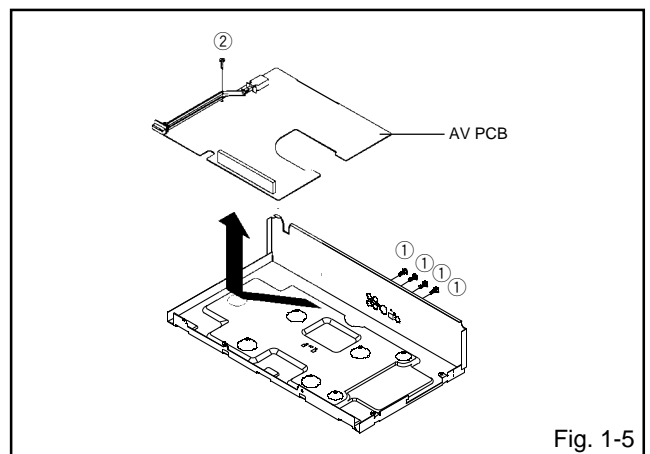

Fig. 1-5

DISASSEMBLY INSTRUCTIONS

2. REMOVAL AND INSTALLATION OF FLAT PACKAGE IC

REMOVAL

1. Put the Masking Tape (cotton tape) around the Flat Package IC to protect other parts from any damage. (Refer to Fig. 2-1.)

NOTE

Masking is carried out on all the parts located within 10 mm distance from IC leads.

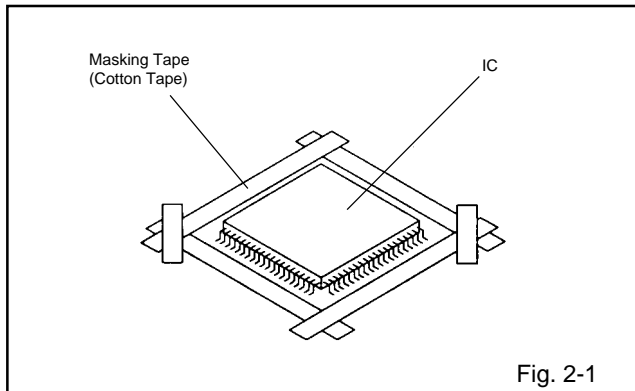

2. Heat the IC leads using a blower type IC desoldering machine. (Refer to Fig. 2-2.)

NOTE

Do not add the rotating and the back and forth directions force on the IC, until IC can move back and forth easily after desoldering the IC leads completely.

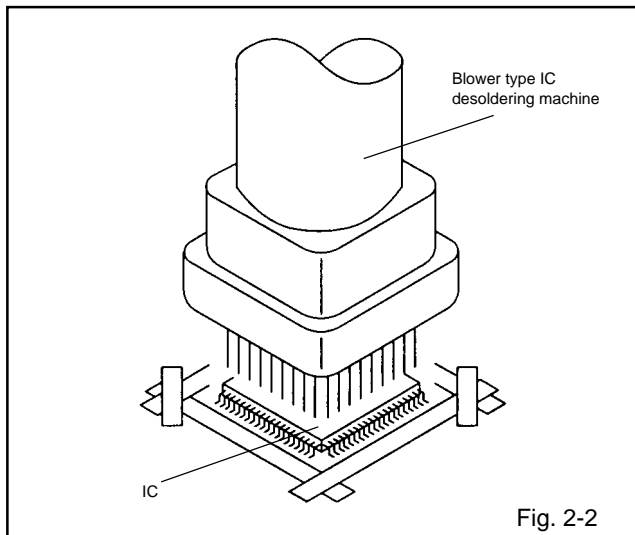

3. When IC starts moving back and forth easily after desoldering completely, pickup the corner of the IC using a tweezers and remove the IC by moving with the IC desoldering machine. (Refer to Fig. 2-3.)

NOTE

Some ICs on the PCB are affixed with glue, so be careful not to break or damage the foil of each IC leads or solder lands under the IC when removing it.

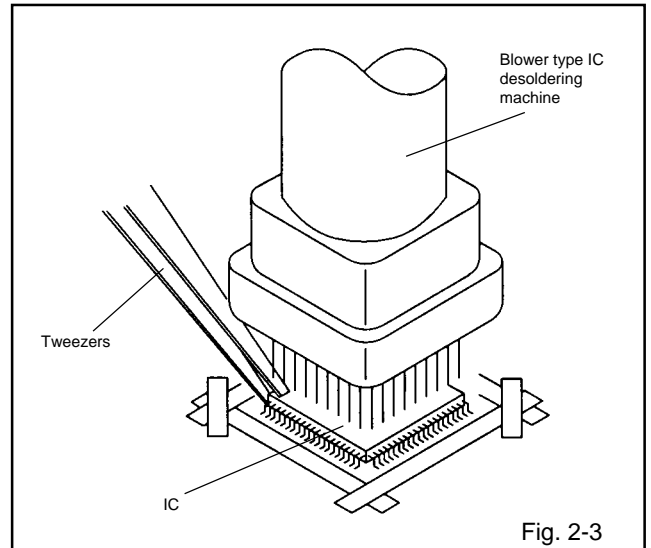

4. Peel off the Masking Tape.
5. Absorb the solder left on the pattern using the Braided Shield Wire. (Refer to Fig. 2-4.)

NOTE

Do not move the Braided Shield Wire in the vertical direction towards the IC pattern.

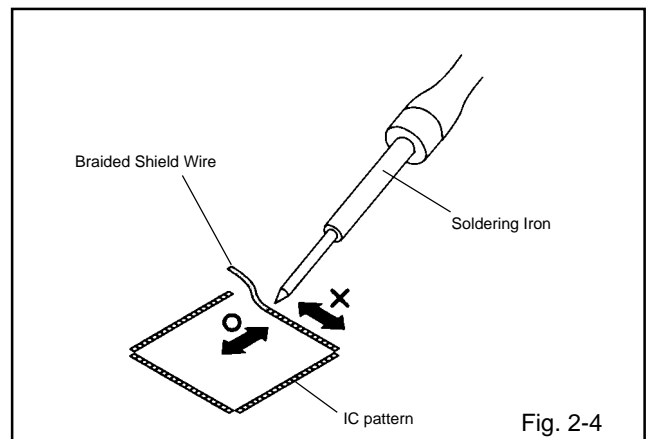

DISASSEMBLY INSTRUCTIONS

INSTALLATION

1. Take care of the polarity of new IC and then install the new IC fitting on the printed circuit pattern. Then solder each lead on the diagonal positions of IC temporarily. (Refer to Fig. 2-5.)

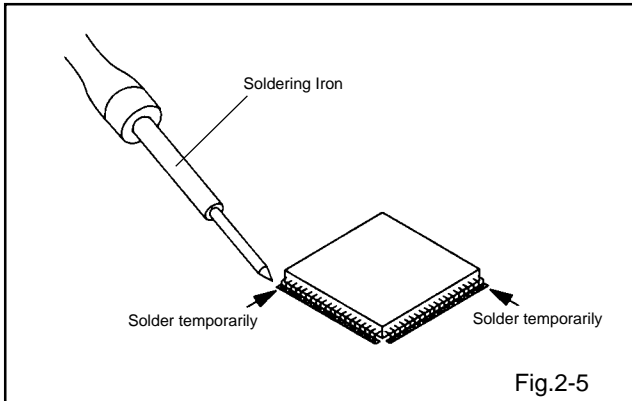

2. Supply the solder from the upper position of IC leads sliding to the lower position of the IC leads. (Refer to Fig. 2-6.)

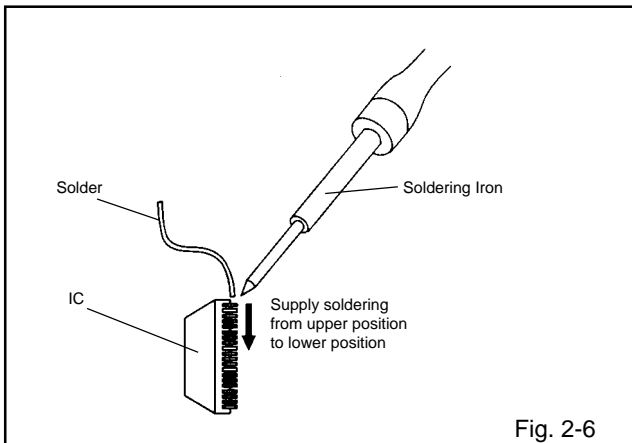

3. Absorb the solder left on the lead using the Braided Shield Wire. (Refer to Fig. 2-7.)

NOTE

Do not absorb the solder to excess.

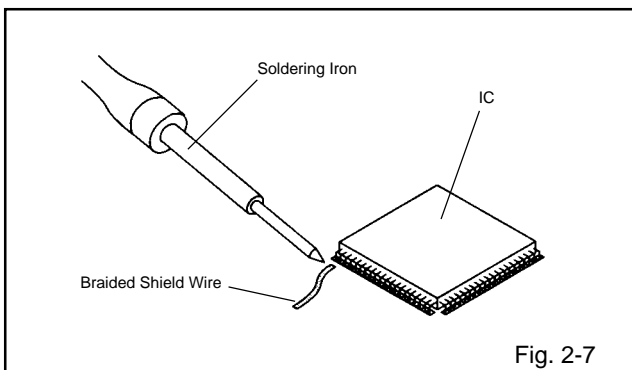

4. When bridge-soldering between terminals and/or the soldering amount are not enough, resolder using a Thin-tip Soldering Iron. (Refer to Fig. 2-8.)

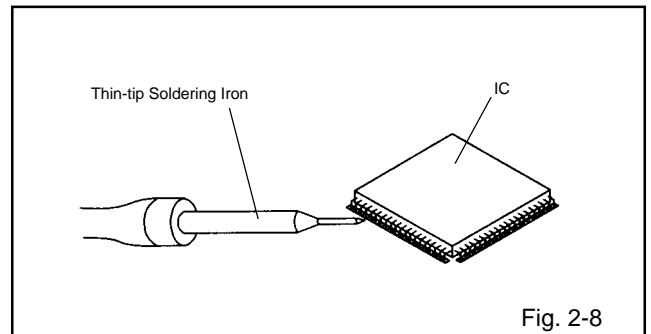

5. Finally, confirm the soldering status on four sides of the IC using a magnifying glass. Confirm that no abnormality is found on the soldering position and installation position of the parts around the IC. If some abnormality is found, correct by resoldering.

NOTE

When the IC leads are bent during soldering and/or repairing, do not repair the bending of leads. If the bending of leads are repaired, the pattern may be damaged. So, be always sure to replace the IC in this case.

PRINTED CIRCUIT BOARDS
SYSCON

(TOP SIDE)

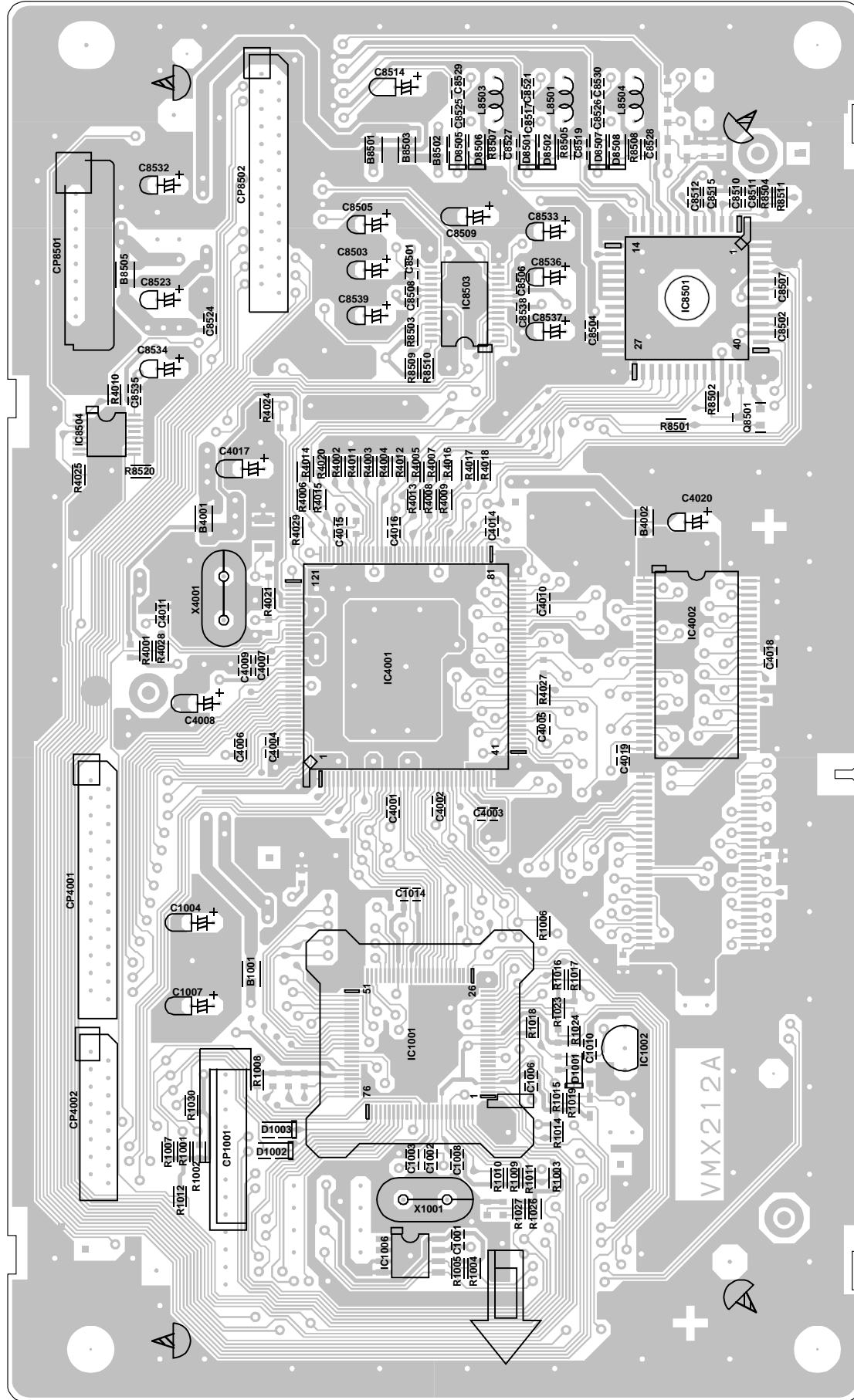

(BOTTOM SIDE)

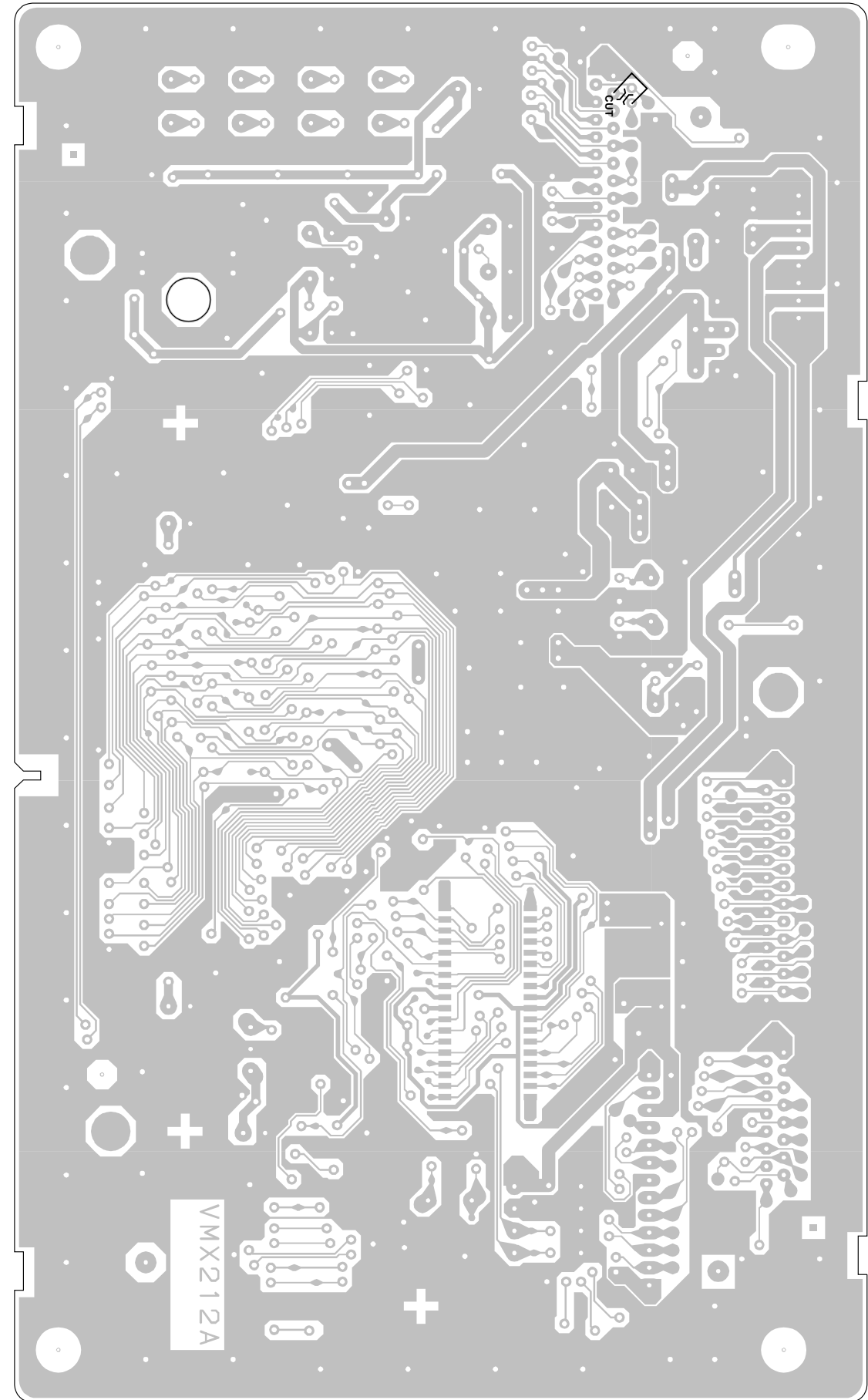

PRINTED CIRCUIT BOARDS
AV (CHIP MOUNTED PARTS)
SOLDER SIDE

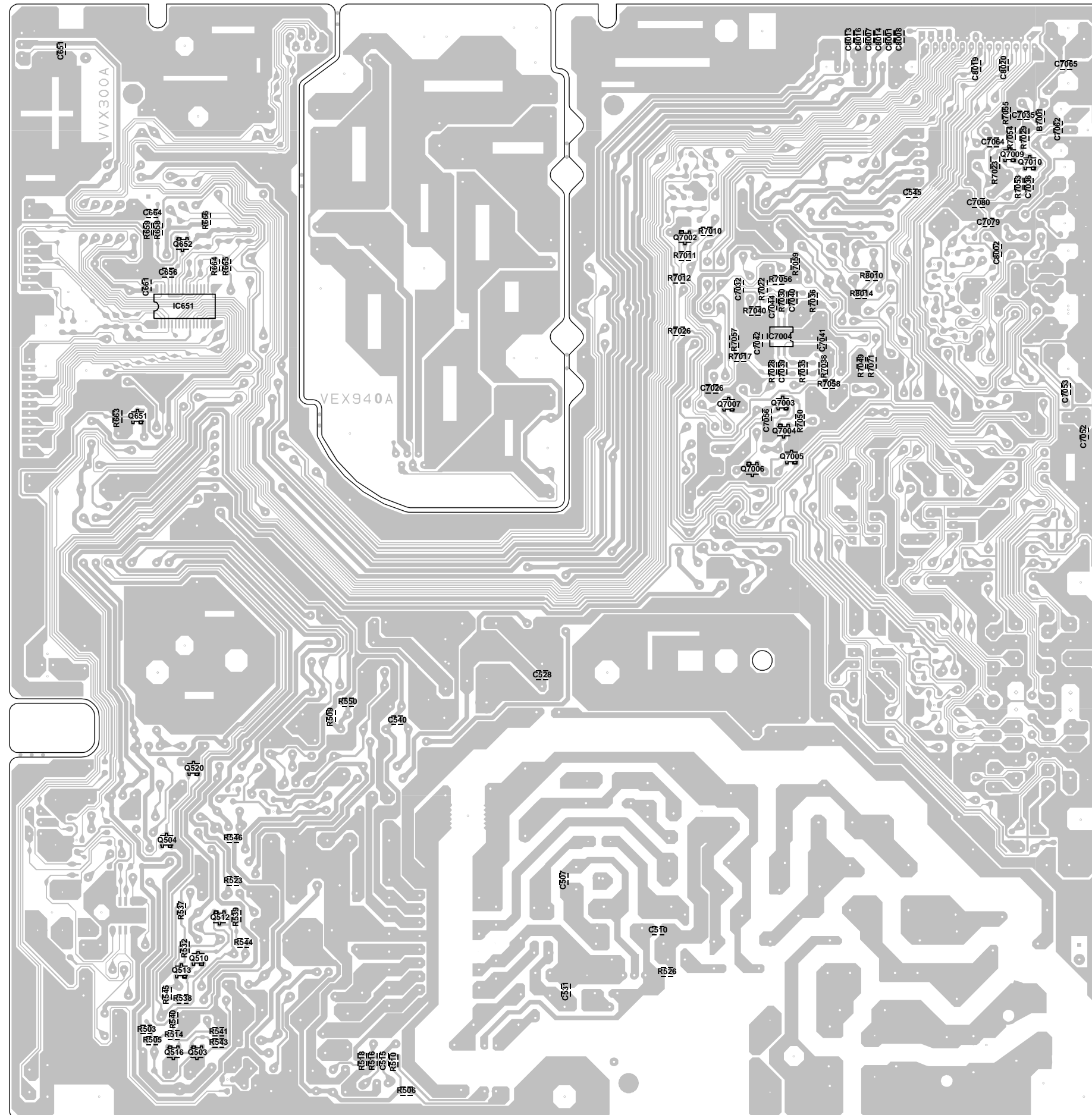

DVD BLOCK DIAGRAM

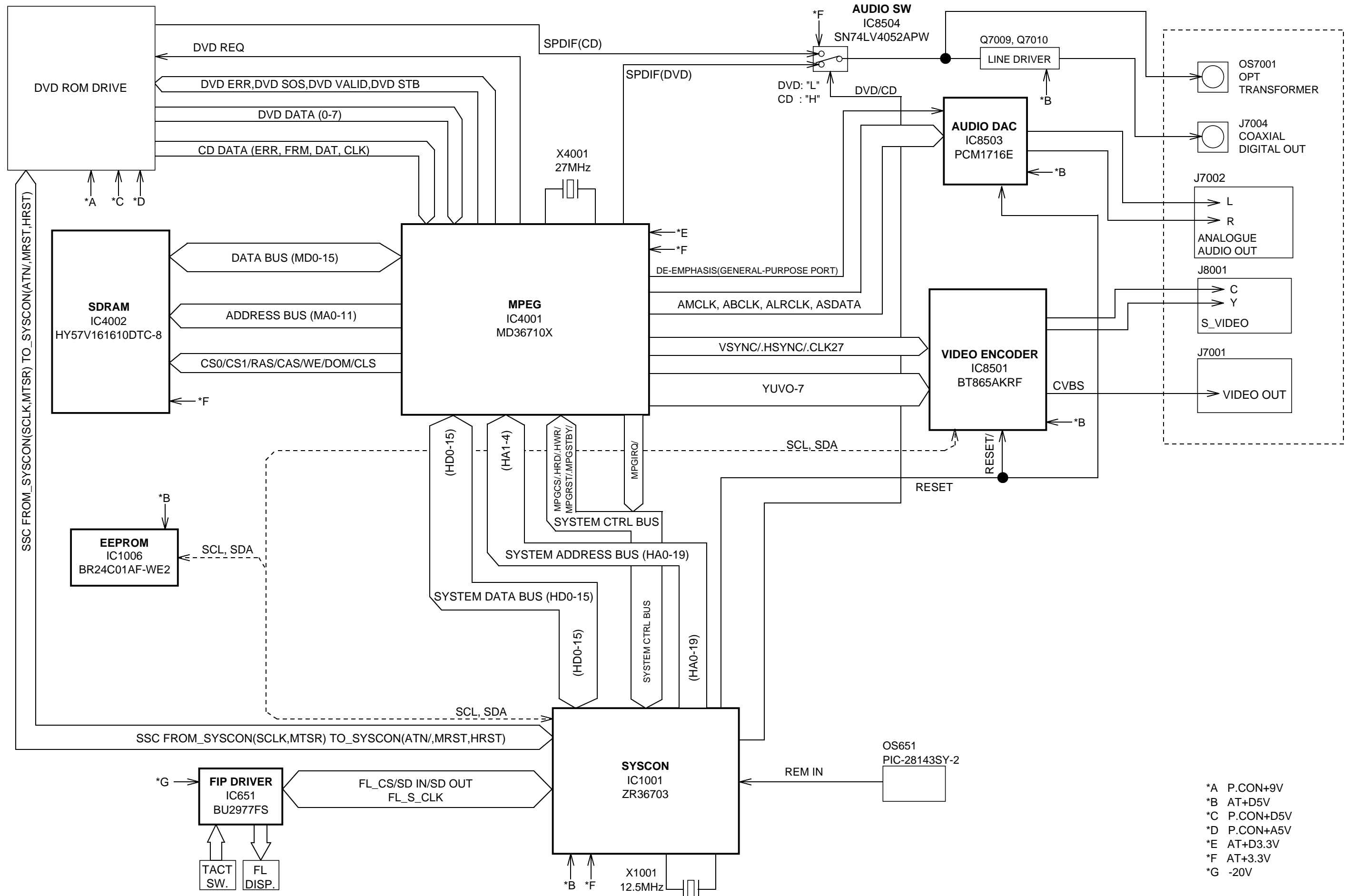

- *A P.CON+9V
- *B AT+D5V
- *C P.CON+D5V
- *D P.CON+A5V
- *E AT+D3.3V
- *F AT+3.3V
- *G -20V

POWER BLOCK DIAGRAM

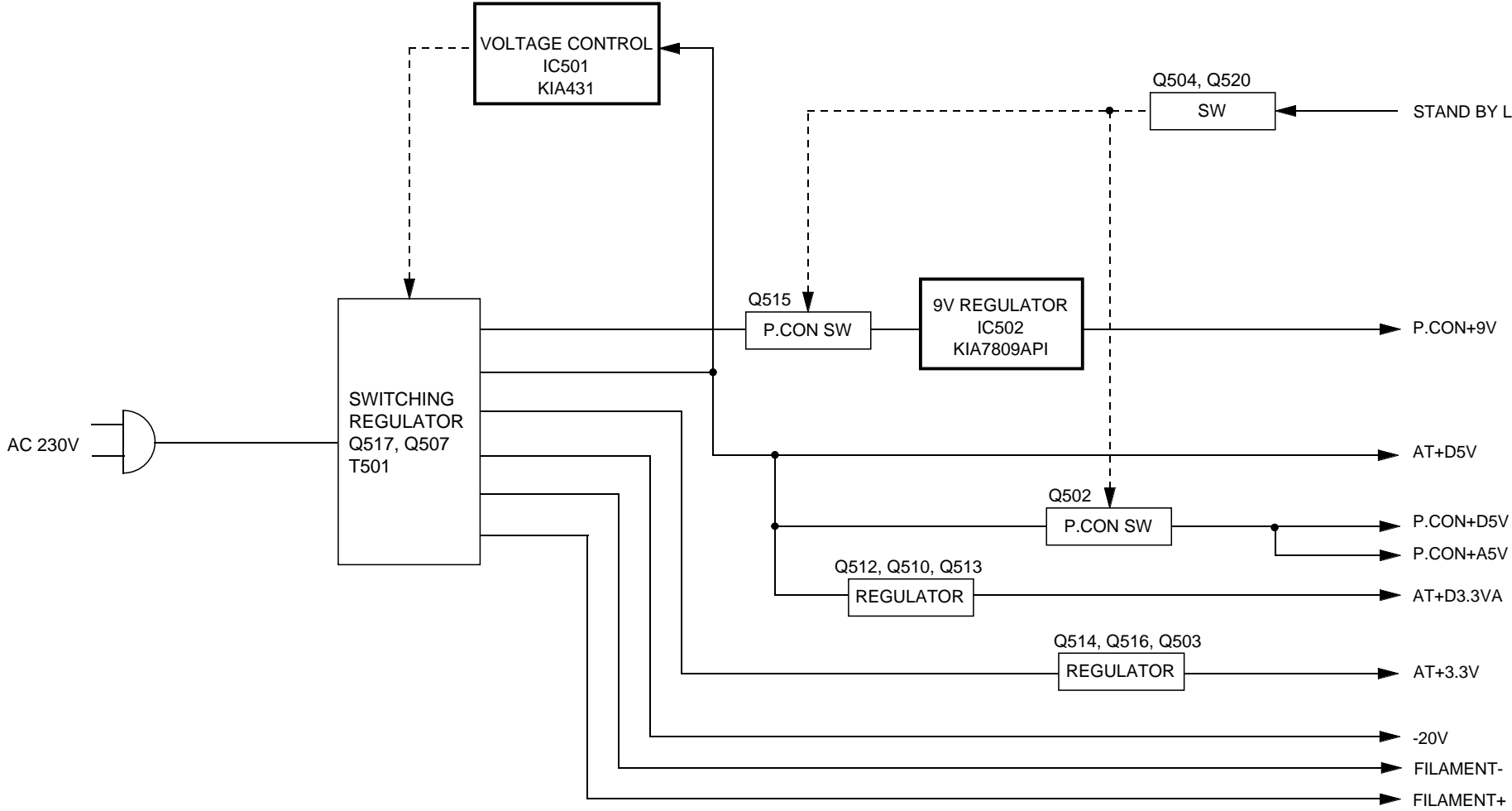

MPEG SCHEMATIC DIAGRAM (SYSCON PCB)

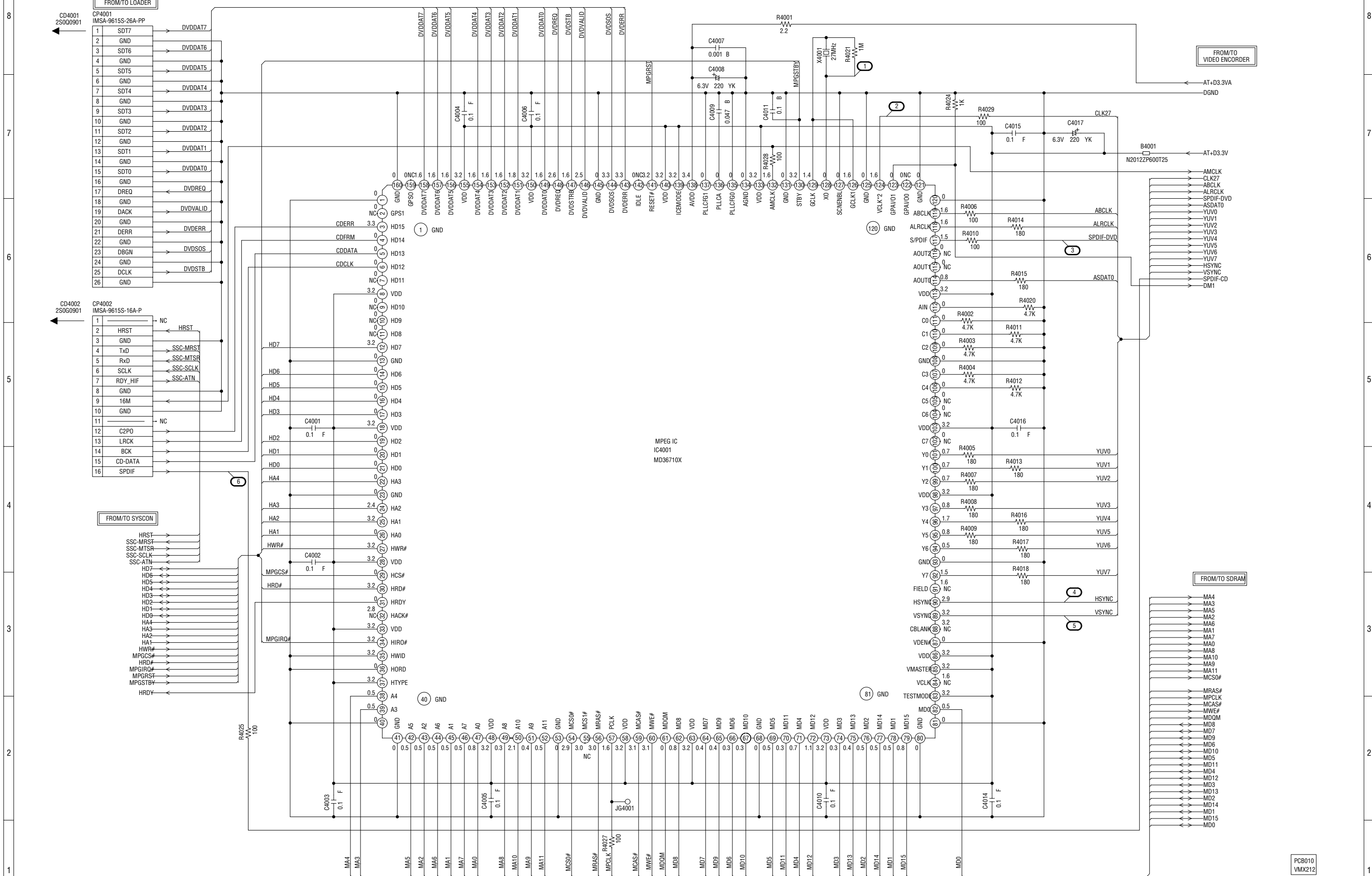

NOTE: THIS SCHEMATIC DIAGRAM IS THE LATEST AT THE TIME OF PRINTING AND SUBJECT TO CHANGE WITHOUT NOTICE.

NOTE: THE DC VOLTAGE AT EACH PART WAS MEASURED WITH THE DIGITAL TESTER DURING PLAYBACK.

SDRAM SCHEMATIC DIAGRAM (SYSCON PCB)

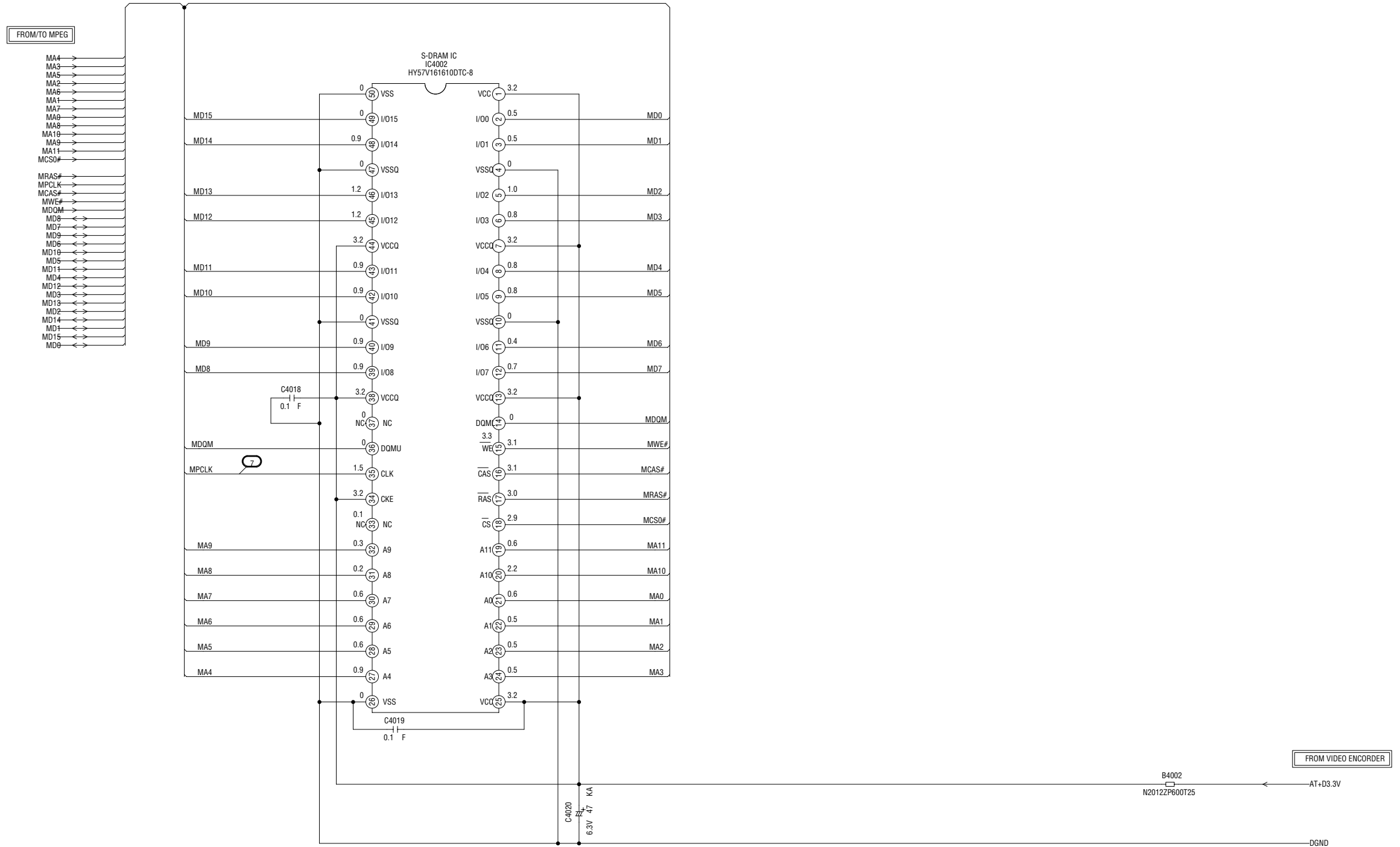

NOTE: THIS SCHEMATIC DIAGRAM IS THE LATEST AT THE TIME OF PRINTING AND SUBJECT TO CHANGE WITHOUT NOTICE.

NOTE: THE DC VOLTAGE AT EACH PART WAS MEASURED WITH THE DIGITAL TESTER DURING PLAYBACK.

PCB010
VMX212

SYSCON SCHEMATIC DIAGRAM (SYSCON PCB)

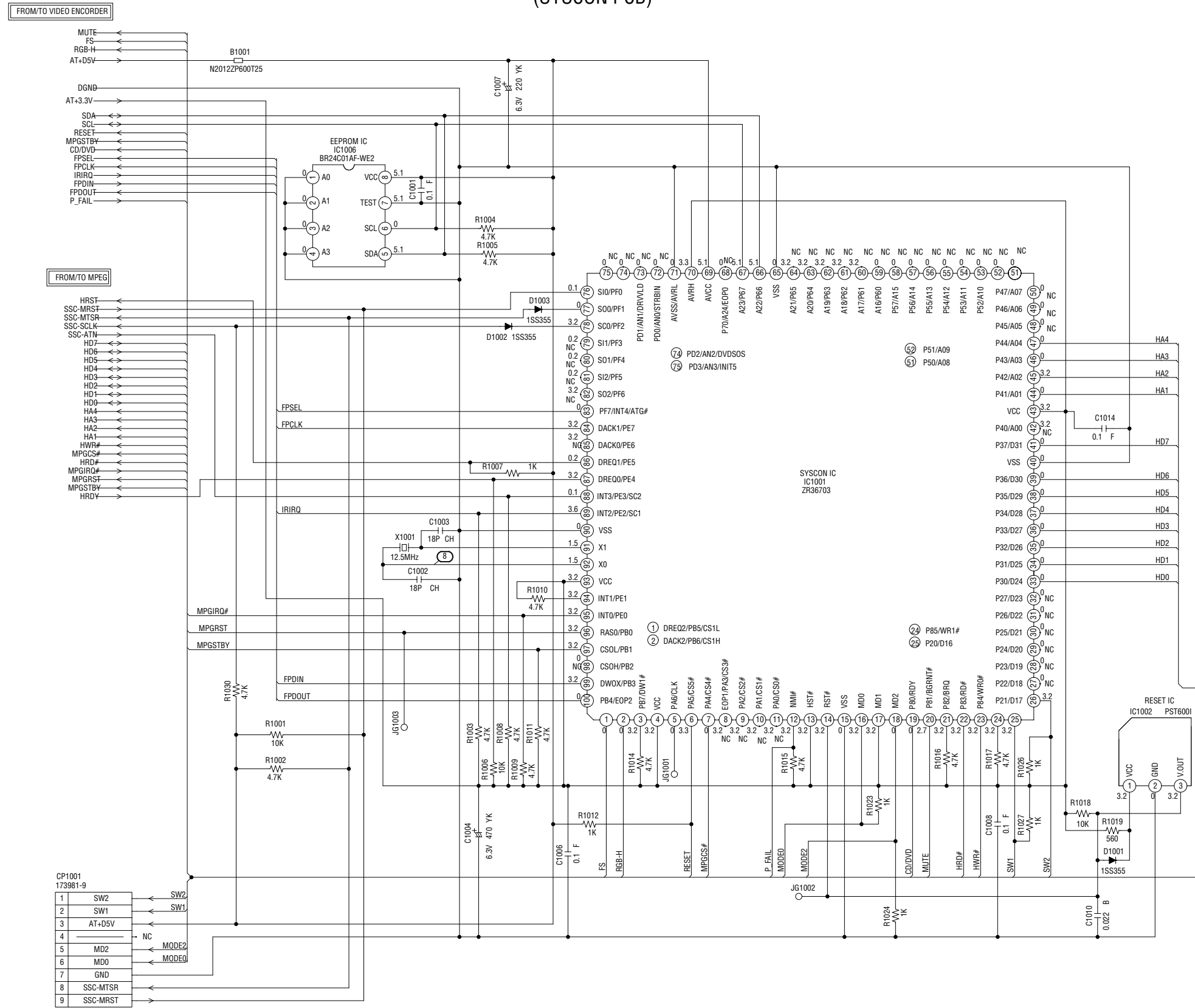

NOTE: THIS SCHEMATIC DIAGRAM IS THE LATEST AT THE TIME OF PRINTING AND SUBJECT TO CHANGE WITHOUT NOTICE.

NOTE: THE DC VOLTAGE AT EACH PART WAS MEASURED WITH THE DIGITAL TESTER DURING PLAYBACK.

PCB010
VMX212

VIDEO ENCODER SCHEMATIC DIAGRAM (SYSCON PCB)

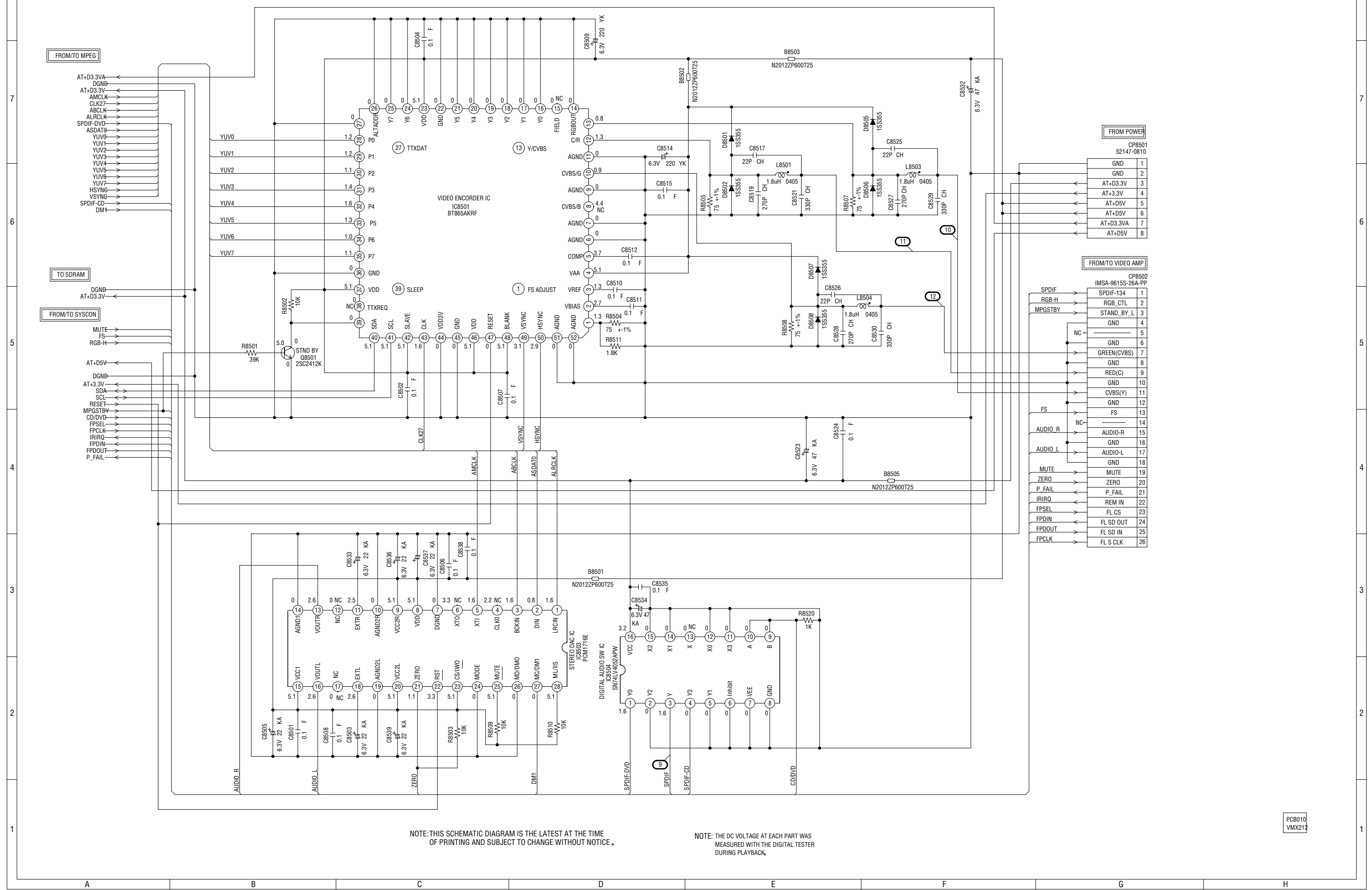

FROM/TO MPEG

TO SDRAM

FROM/TO SYSCON

FROM POWER

FROM/TO VIDEO AMP

NOTE: THIS SCHEMATIC DIAGRAM IS THE LATEST AT THE TIME OF PRINTING AND SUBJECT TO CHANGE WITHOUT NOTICE .

NOTE: THE DC VOLTAGE AT EACH PART WAS MEASURED WITH THE DIGITAL TESTER DURING PLAYBACK.

PCB010
VMX212

CP8501	
52147-0810	
GND	1
GND	2
AT+D3.3V	3
AT+3.3V	4
AT+D5V	5
AT+D5V	6
AT+D3.3VA	7
AT+D5V	8

CP8502	
IMSA-9615S-26A-PP	
SPDIF	SPDIF-134 1
RGB-H	RGB_CTL 2
MPGSTBY	STAND_BY_L 3
	GND 4
	5
	GND 6
	GREEN(CVBS) 7
	GND 8
	RED(C) 9
	GND 10
	CVBS(Y) 11
	GND 12
FS	FS 13
	14
AUDIO_R	AUDIO-R 15
	GND 16
AUDIO_L	AUDIO-L 17
	GND 18
MUTE	MUTE 19
ZERO	ZERO 20
P_FAIL	P_FAIL 21
IRIRQ	REM IN 22
FPSEL	FL CS 23
FPDIN	FL SD OUT 24
FPDOUT	FL SD IN 25
FPCLK	FL S CLK 26

VIDEO AMP SCHEMATIC DIAGRAM (AV PCB)

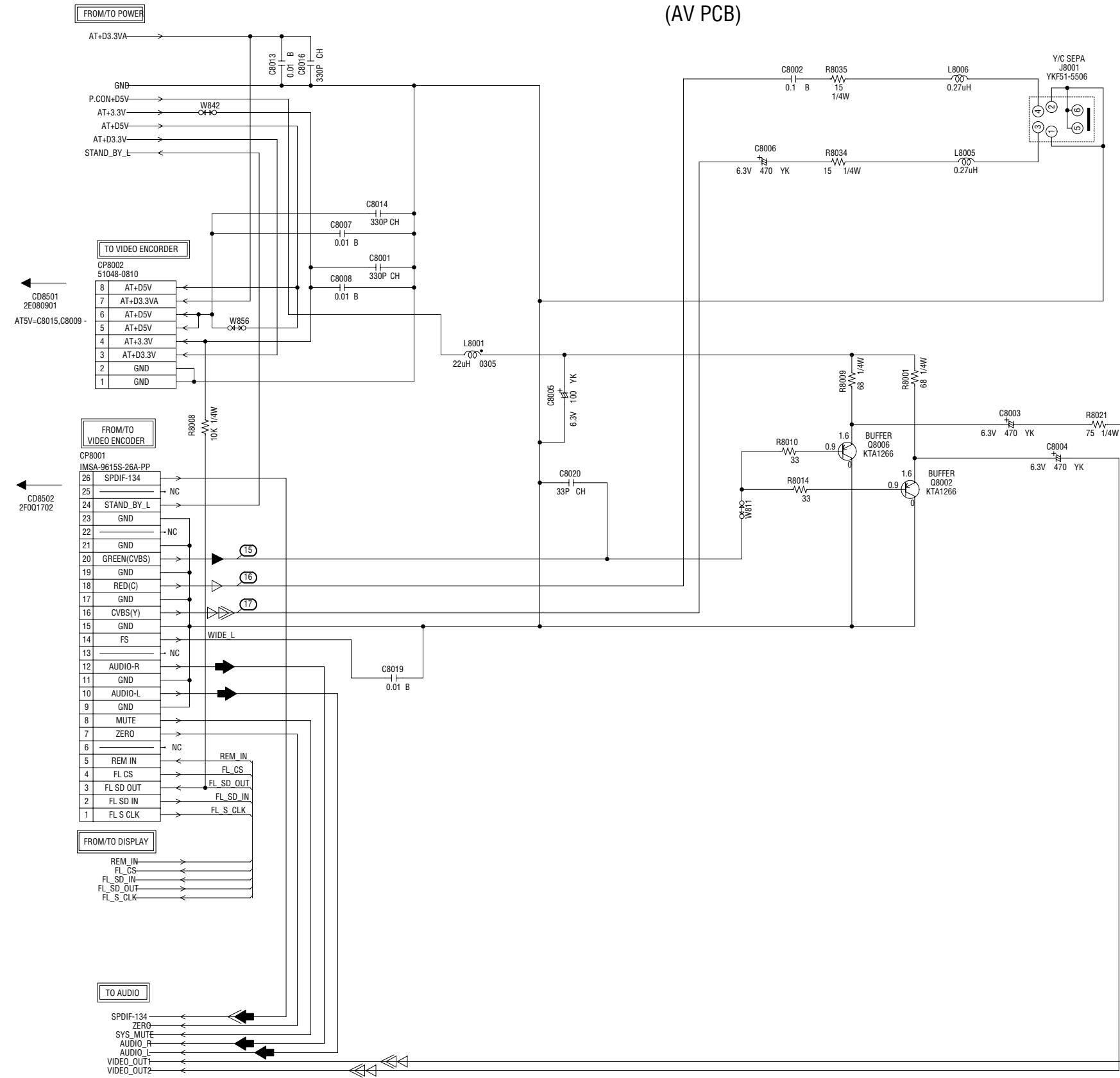

NOTE: THIS SCHEMATIC DIAGRAM IS THE LATEST AT THE TIME OF PRINTING AND SUBJECT TO CHANGE WITHOUT NOTICE.

NOTE: THE DC VOLTAGE AT EACH PART WAS MEASURED WITH THE DIGITAL TESTER DURING PLAYBACK.

- ◀ DIGITAL AUDIO SIGNAL (PB)
- ▶ PLAYBACK LUMINANCE SIGNAL
- ◀▶ PLAYBACK COLOR SIGNAL
- ▶▶▶ PLAYBACK VIDEO SIGNAL
- ▶▶▶▶ AUDIO SIGNAL (PB)

PCB060
VVX300

AUDIO SCHEMATIC DIAGRAM (AV PCB)

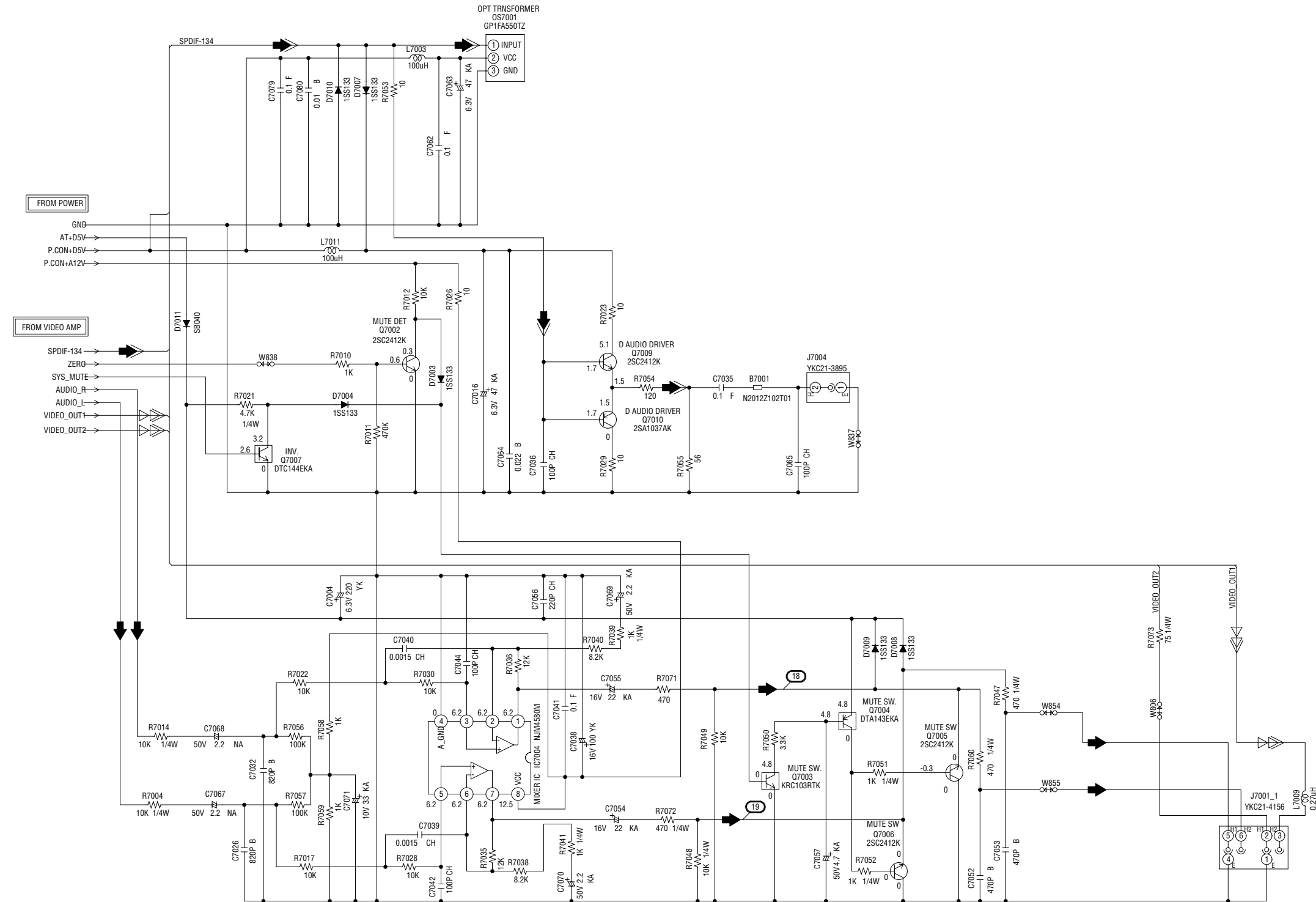

NOTE: THE DC VOLTAGE AT EACH PART WAS MEASURED WITH THE DIGITAL TESTER DURING PLAYBACK.

NOTE: THIS SCHEMATIC DIAGRAM IS THE LATEST AT THE TIME OF PRINTING AND SUBJECT TO CHANGE WITHOUT NOTICE.

AUDIO SIGNAL (PB)
 DIGITAL AUDIO SIGNAL (PB)
 PLAYBACK VIDEO SIGNAL

CAUTION: DIGITAL TRANSISTOR

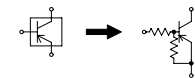

CAUTION: DIGITAL TRANSISTOR

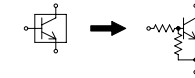

PCB060
VVX300

OPERATION SCHEMATIC DIAGRAM (AV PCB)

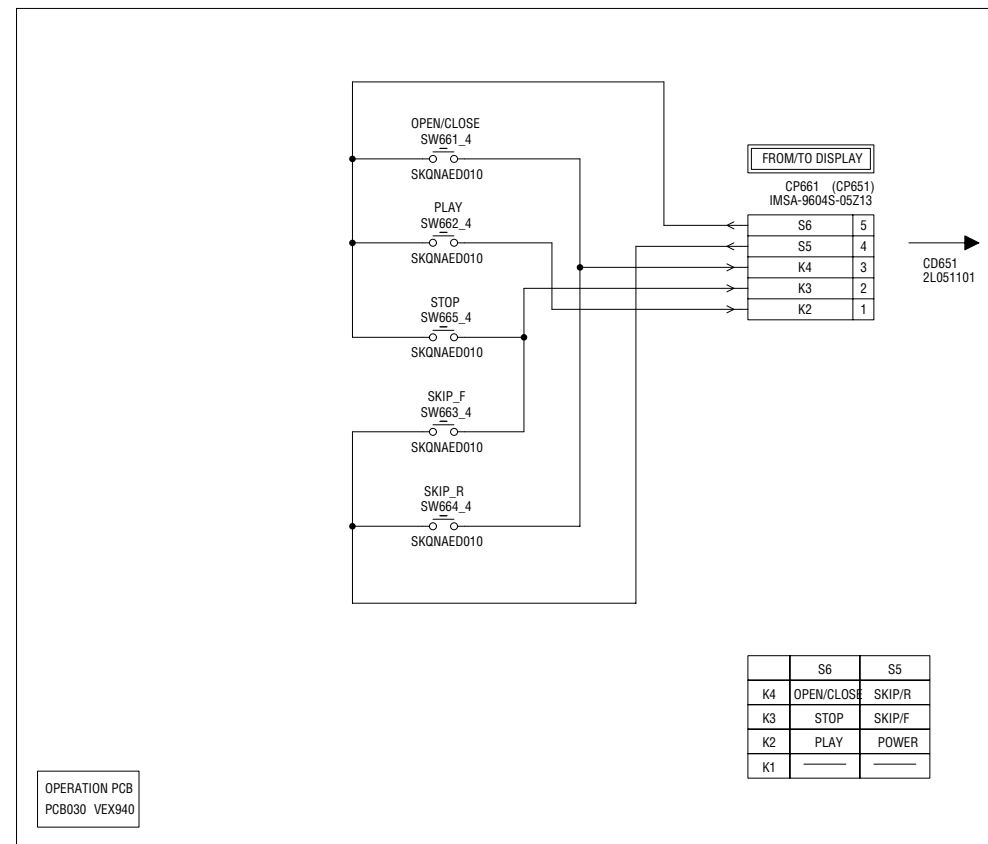

NOTE: THE DC VOLTAGE AT EACH PART WAS MEASURED WITH THE DIGITAL TESTER DURING PLAYBACK.

NOTE: THIS SCHEMATIC DIAGRAM IS THE LATEST AT THE TIME OF PRINTING AND SUBJECT TO CHANGE WITHOUT NOTICE.

POWER SCHEMATIC DIAGRAM (AV PCB)

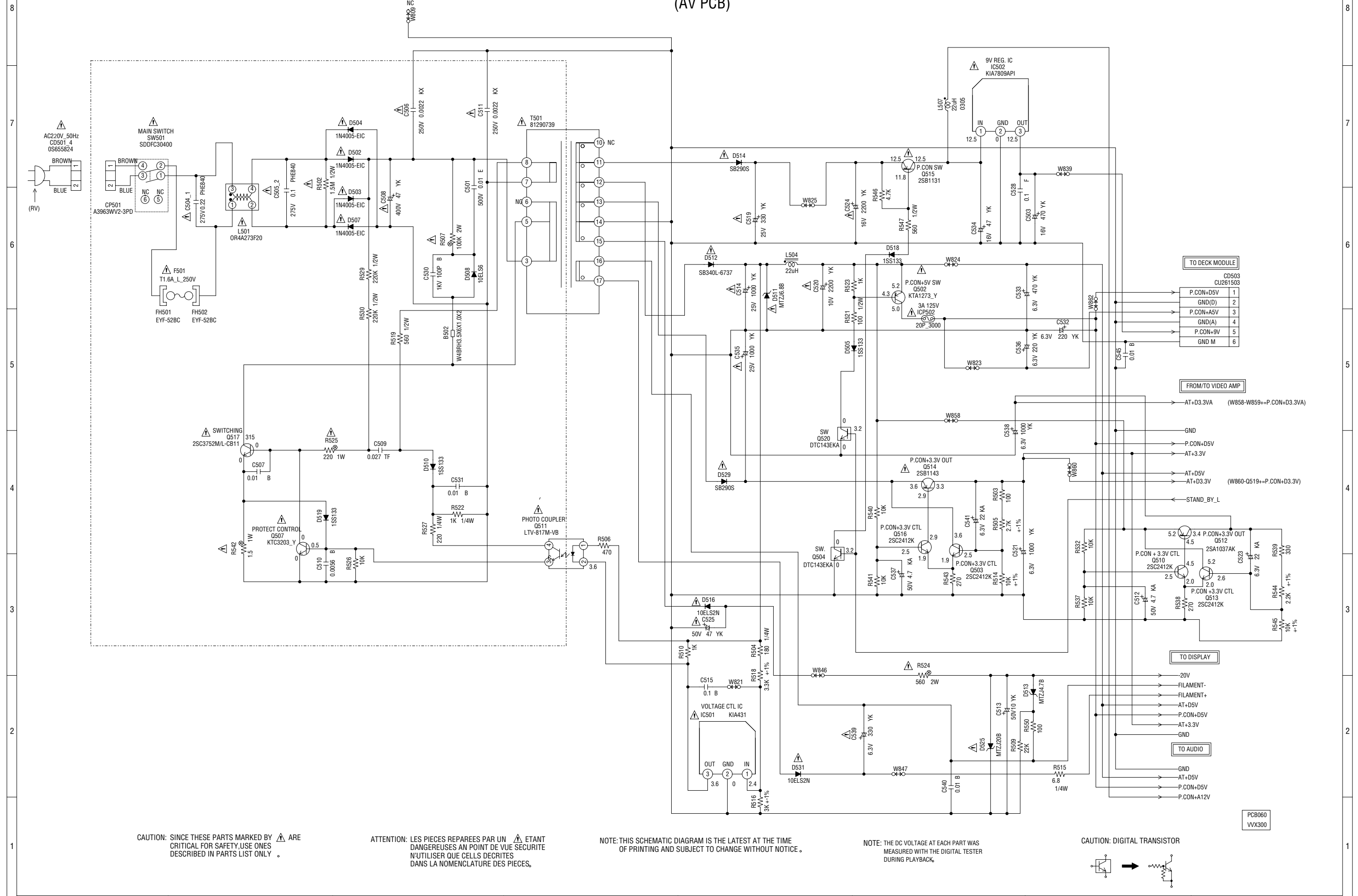

CAUTION: SINCE THESE PARTS MARKED BY ARE CRITICAL FOR SAFETY USE ONES DESCRIBED IN PARTS LIST ONLY.

ATTENTION: LES PIÈCES REPAREES PAR UN ETANT DANGEREUSES AN POINT DE VUE SECURITE N'UTILISER QUE CELLS DECRITES DANS LA NOMENCLATURE DES PIÈCES.

NOTE: THIS SCHEMATIC DIAGRAM IS THE LATEST AT THE TIME OF PRINTING AND SUBJECT TO CHANGE WITHOUT NOTICE.

NOTE: THE DC VOLTAGE AT EACH PART WAS MEASURED WITH THE DIGITAL TESTER DURING PLAYBACK.

CAUTION: DIGITAL TRANSISTOR

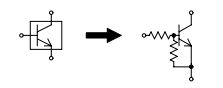

TO DECK MODULE

CD503	
CU261503	
P.CON+5V	1
GND(D)	2
P.CON+5V	3
GND(A)	4
P.CON+9V	5
GND M	6

FROM/TO VIDEO AMP

AT+D3.3VA	(W858-W859→P.CON+D3.3VA)
GND	
P.CON+5V	
AT+3.3V	
AT+D5V	
AT+D3.3V	(W860-Q519→P.CON+D3.3V)
STAND_BY_L	

TO DISPLAY

20V	
FILAMENT-	
FILAMENT+	
AT+D5V	
P.CON+5V	
AT+3.3V	
GND	

TO AUDIO

GND	
AT+D5V	
P.CON+5V	
P.CON+12V	

PCB060
VVX300

DISPLAY SCHEMATIC DIAGRAM (AV PCB)

V651 HNV-06SS71

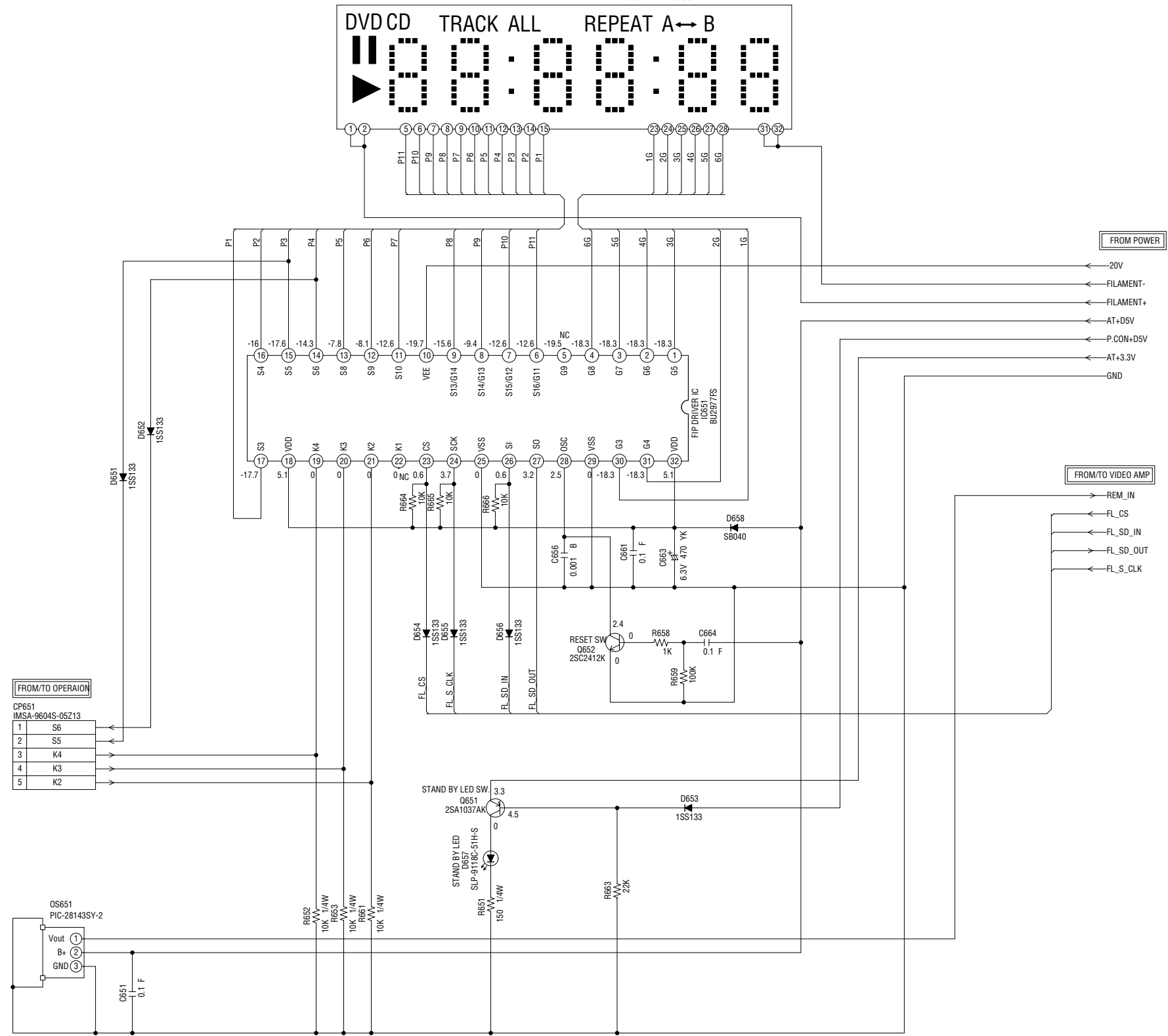

FROM/TO OPERATION

1	S6
2	S5
3	K4
4	K3
5	K2

OS651 PIC-28143SY-2

Vout	①
B+	②
GND	③

NOTE: THIS SCHEMATIC DIAGRAM IS THE LATEST AT THE TIME OF PRINTING AND SUBJECT TO CHANGE WITHOUT NOTICE.

NOTE: THE DC VOLTAGE AT EACH PART WAS MEASURED WITH THE DIGITAL TESTER DURING PLAYBACK.

CAUTION: DIGITAL TRANSISTOR

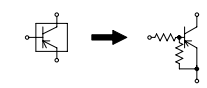

PCB060
VWX300

INTERCONNECTION DIAGRAM

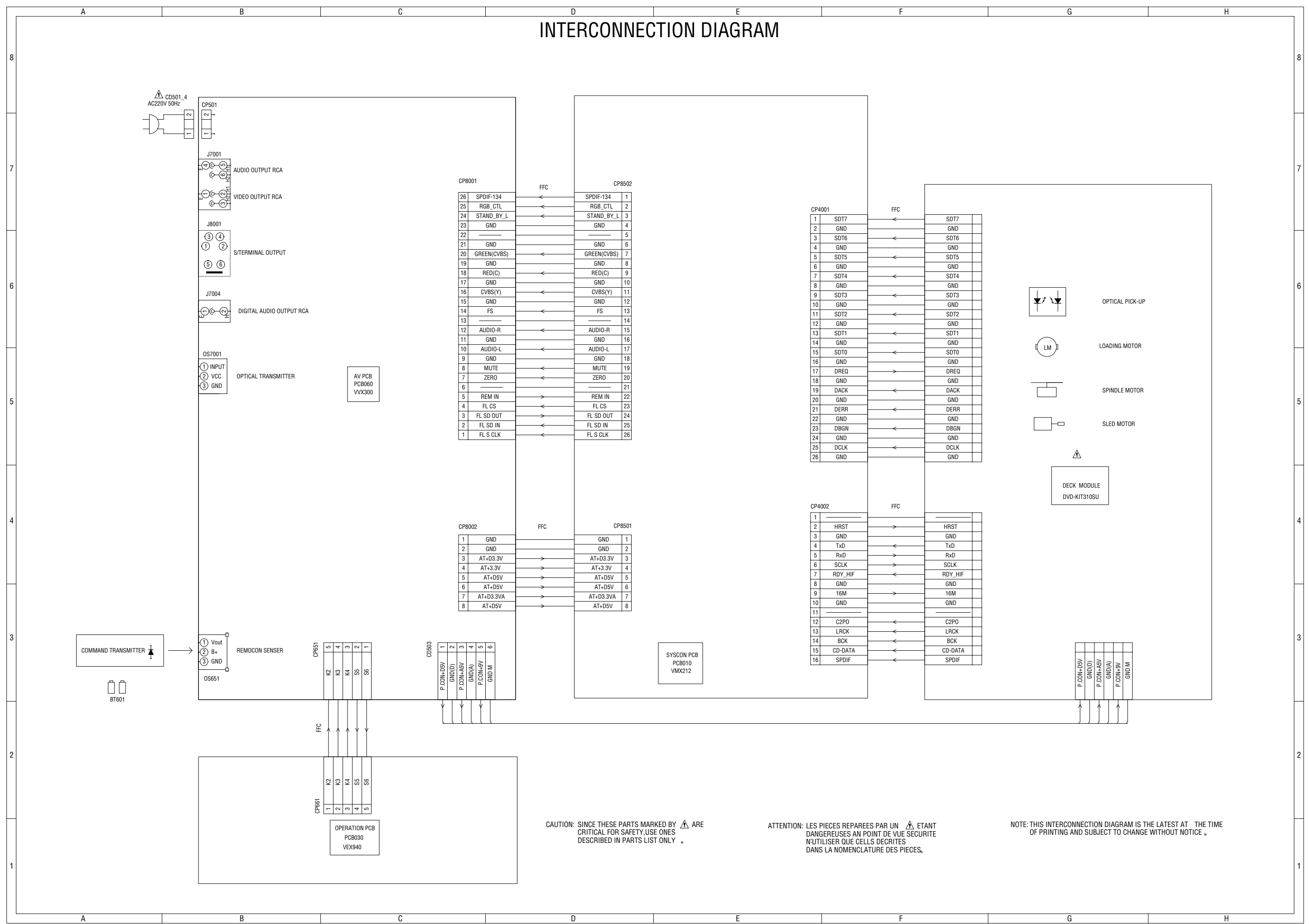

CAUTION: SINCE THESE PARTS MARKED BY ARE CRITICAL FOR SAFETY, USE ONES DESCRIBED IN PARTS LIST ONLY .

ATTENTION: LES PIECES REPARÉES PAR UN ÉTANT DANGEREUSES AN POINT DE VUE SECURITE N'UTILISER QUE CELLS DECRITES DANS LA NOMENCLATURE DES PIECES.

NOTE: THIS INTERCONNECTION DIAGRAM IS THE LATEST AT THE TIME OF PRINTING AND SUBJECT TO CHANGE WITHOUT NOTICE .