

# HITACHI

## SERVICE MANUAL

SM0607

DV-DS163E  
DV-DS163E(UK)  
DV-DS253E  
DV-DS253E(UK)



**HDMI VIDEO *plus+* SHOWVIEW<sup>®</sup>**

DO NOT RESELL OR DIVERT IMPROPERLY.

SPECIFICATIONS AND PARTS ARE SUBJECT TO CHANGE FOR IMPROVEMENT

HDD/DVD RECORDER

May 2006

# Table of Contents

<b>1 Safety Precaution for Repair.....</b>	<b>1-1</b>	(1) Top Cover, Fan .....	4-2
1-1 Cautions .....	1-1	(2) Front Block .....	4-3
1-2 Electrostatic Protection Measures.....	1-2	(3) TIMER-1 P.C.B, TIMER-2 P.C.B, Front Panel .....	4-3
1-3 Cautions When Handling DVD Drive .....	1-2	(4) MAIN P.C.B .....	4-4
1-4 Cautions When Handling HDD .....	1-3	(5) Power Cable, SMPS P.C.B .....	4-5
1-5 Lead-Free Solder.....	1-4	(6) HDMI Block, HDMI P.C.B .....	4-6
1-6 Notes When Using Service Manual.....	1-5	(7) Front Frame, DVD Block, DVD Drive Unit, LOADER P.C.B.....	4-7
<b>2 General Description.....</b>	<b>2-1</b>	(8) HDD Block, HDD P.C.B, HDD .....	4-8
2-1 Overview .....	2-1	(9) CARD P.C.B .....	4-9
2-1-1 Service method .....	2-1	(10) I/O P.C.B.....	4-10
2-1-2 Disc information.....	2-2	(11) Rear Panel .....	4-10
2-2 Specifications .....	2-4		
2-3 Major Differences from Previous Model ..	2-5		
2-4 Function Differences from Previous Model .....	2-6		
2-5 Names of Parts.....	2-7		
2-6 HDMI Connection.....	2-10		
2-7 List of Abbreviations and Terms for DVD Recorder.....	2-11		
<b>3 Details of Servicing and Troubleshooting.....</b>	<b>3-1</b>		
3-1 How to Remove Disc from Faulty Recorder.....	3-1		
3-2 Initialization.....	3-2		
3-2-1 Factory Set .....	3-2		
3-2-2 HDD Format .....	3-2		
3-3 Troubleshooting HDD .....	3-3		
3-4 Checking Versions of Firmware and Updating .....	3-4		
3-4-1 Version check procedure .....	3-4		
3-4-2 Method of starting up firmware update program .....	3-4		
3-4-3 Main firmware updating procedure .....	3-5		
3-4-4 Loader firmware updating procedure ..	3-6		
3-4-5 Main/Loader firmware simultaneous updating procedure .....	3-6		
3-5 Troubleshooting .....	3-7		
3-5-1 Troubleshooting electronic system .....	3-7		
<b>4 Disassembly and Reassembly.....</b>	<b>4-1</b>		
4-1 Order of Disassembly .....	4-1		
4-2 Disassembly .....	4-2		
		<b>5 Exploded View and Parts List .....</b>	<b>5-1</b>
		5-1 Exploded View.....	5-1
		5-2 Parts List .....	5-2
		<b>S Schematic, Wiring Diagrams.....</b>	<b>S-1</b>
		S-1 Wiring Diagram.....	S-1
		S-2 SMPS Schematic Diagram.....	S-2
		S-3 POWER Schematic Diagram (I/O P.C.B) ....	S-3
		S-4 TUNER/SYSTEM Schematic Diagram (I/O P.C.B).....	S-4
		S-5 JACK Schematic Diagram (I/O P.C.B) .....	S-5
		S-6 DECODER Schematic Diagrams (I/O P.C.B).....	S-6
		S-7 TIMER-1, TIMER-2 Schematic Diagram (TIMER-1, TIMER-2 P.C.B).....	S-7
		S-8 HDMI Schematic Diagram (HDMI P.C.B)..	S-8
		-TO BE ADDED-	
		S-9 Circuit Waveforms .....	S-9
		S-10 Circuit Voltage Chart .....	S-10
		<b>C Circuit Board Diagrams.....</b>	<b>C-1</b>
		C-1 I/O Circuit Board Diagram .....	C-1
		C-2 SMPS Circuit Board Diagram.....	C-3
		C-3 TIMER-1 Circuit Board Diagram.....	C-3
		C-4 TIMER-2 Circuit Board Diagram.....	C-3
		C-5 HDMI Circuit Board Diagram.....	C-4
		C-6 HDD Circuit Board Diagram .....	C-4

<b>B Block Diagrams.....</b>	<b>B-1</b>
B-1 Overall Block Diagram .....	B-1
B-2 SMPS Circuit Block Diagram.....	B-2
B-3 POWER (I/O Board) Circuit Block Diagram .....	B-3
B-4 AUDIO/VIDEO Circuit Block Diagram.....	B-4
B-5 SYSTEM Circuit Block Diagram .....	B-5

## 1-1 Cautions

### PRODUCT SAFETY NOTICE

Many electrical and mechanical parts have special safety-related characteristics. These are often not evident from visual inspection nor can the protection afforded by them necessarily be obtained by using replacement components rated for a higher voltage, wattage, etc. Replacement parts which have these special safety characteristics are identified in this Service Manual. Electrical components having such features are identified by marking with a  $\triangle$  on the schematics and the parts list in this Service Manual. The use of a substitute replacement component which does not have the same safety characteristics as the HITACHI recommended replacement one, shown in the parts list in this Service Manual, may create shock, fire, or other hazards. Product safety is continuously under review and new instructions are issued from time to time. For the latest information, always consult the current HITACHI Service Manual. A subscription to, or additional copies for, HITACHI Service Manual may be obtained at a nominal charge from HITACHI SALES CORPORATION.

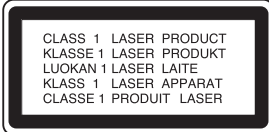

#### CAUTION

This product contains a laser diode of higher class than 1. To ensure continued safety, do not remove any covers or attempt to gain access to the inside of the product. Refer all servicing to qualified personnel.

#### CAUTION

There is a high-voltage section inside the DVD video recorder. When repairing or inspecting it, take great care to prevent electric shock: Use an isolating transformer, wear gloves, etc.

## 1-2 Electrostatic Protection Measures

Semiconductor components can be damaged by static electricity charged on clothes, human body, etc. Take great care when handling components to avoid electrostatic damage, and perform servicing in an environment where grounding is complete.

### (1) Grounding work bench

Lay out an antistatic mat on work bench, and then use the ground plate to ground the work bench.

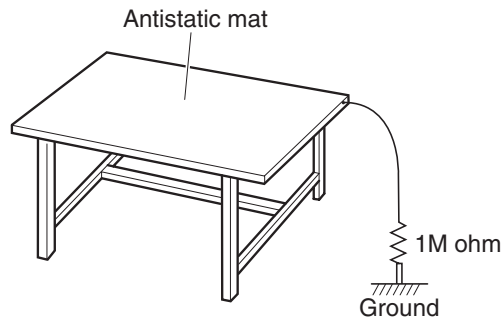

### (2) Grounding human body

Use an antistatic wrist strap to discharge any static electricity charged on the body. Also, use a tester for wrist strap to make sure that the wrist strap is working normally. Note, however, that static electricity charged on clothes will not be discharged by wrist strap: Therefore do not allow your clothes to touch the semiconductor components.

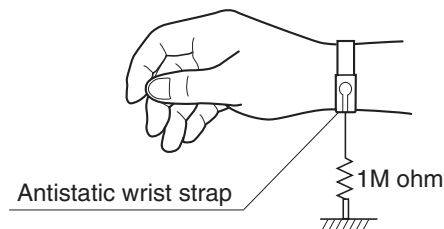

## 1-3 Cautions When Handling DVD Drive

The optical pickup in DVD drive has a high precision structure: Be sure to observe the following cautions.

- 1) Do not subject optical pickups to any severe vibrations or impact during movement, installation or disassembly.
- 2) When performing repair work, do not perform disassembly any further than that described in this manual.
- 3) Never turn the semi-variable resistors for adjustment in optical pickup or DVD drive.
- 4) NEVER look into the objective lens in optical pickup or directly view the laser light: You could lose your eyesight.

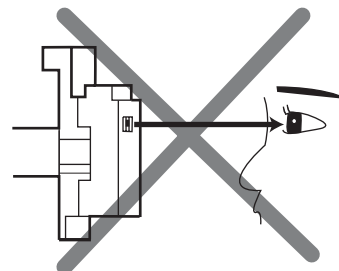

Do not directly look at laser light from pickup.

## 1-4 Cautions When Handling HDD (Hard Disk Drive)

HDD is a high precision device, and is very susceptible to vibrations or impact. Even if HDD operates normally immediately after it has been subjected to vibrations or impact, a problem may occur after it is used for a while. When servicing, take great care with the following.

There are two types of HDD: CSS format (head remains on disk regardless of operation status) and ramp loading format (head moves away from disk during no operation). The impact resistance characteristics are slightly different for the two. When servicing, observe the following cautions regardless of the format:

### (1) Cautions during unpacking

- 1) Do not subject the HDD to any impact when placing on desk: The head hitting against the desk could result in damage.
- 2) If condensation occurs because of the environment, leave the HDD without being turned on for at least 3 hours until it adapts to surrounding environment. If the HDD is turned on while the head is sticking to disk because of condensation, the disk may be damaged.

### (2) Cautions during transportation

An HDD is more susceptible to vibrations or impact when it is turned on or operating than during no operation.

- 1) Do not move the HDD while it is turned on: If the HDD is subject to any impact while the disk is rotating, i.e., the head hitting against the disk, breakage could result.
- 2) Move the HDD approximately 2 minutes (approximately 30 seconds for surveillance system devices) after turning it off and unplugging its power cord from AC outlet. The disk will still be rotating by inertia immediately after the HDD is turned off: Subjecting the HDD to movement at this time could destroy it.

### (3) Cautions during operation

- 1) Do not unplug the power cord from AC outlet during operation: This could damage the data on HDD. Be sure to turn the HDD off before unplugging the power cord.
- 2) Do not hit the HDD: The head hitting the disk could result in breakage.

### (4) Caution during packing

- 1) Use the packing material of relevant model: Material superior in impact resistance is used. Using other packing materials could result in fault.

### (5) Cautions when handling unassembled HDD

- 1) Hold the HDD at both sides so that the circuit board surface is facing below: Holding the HDD at the top and bottom could cause the head to drift, which could result in fault.
- 2) Do not touch the terminal or pattern on circuit board.
- 3) Place HDD on a spot where cushion is pasted with the circuit board surface facing below.
- 4) Do not hold or place stacked HDDs.
- 5) Do not drop or hit HDD against anything: Dropping HDD from even 5 mm high on a work bench with high stiffness could cause fault.

## 1-5 Lead-Free Solder

The printed circuit board that uses lead-free solder is adopted. To protect the global environment, use the recommended lead-free solder also during servicing.

Read and observe the following before soldering:

### Caution

ALWAYS wear protective goggles during soldering so that no solder smoke or scattered solder enters the eye. Lead-free solder may scatter at high temperatures of 600°C.

### (1) Characteristics of lead-free solder

The melting point of lead-free solder is 30-40°C higher than that of lead based solder.

### (2) Lead-free solder for servicing

Use the following lead-free solder for servicing:

Recommended lead-free solder and composition of alloy (wt%): Sn-3.0Ag-0.5Cu or equivalent

### Information:

For composition of alloy, Sn is tin; Ag is silver; Cu is copper; Bi is bismuth; Pb is lead.

### (3) Soldering iron for servicing

The temperature of soldering iron tip must be adjusted according to the points to be soldered: Use an antistatic soldering iron with thermal control function.

When removing components, take care not to damage any surrounding component or pattern. When attaching components, observe the heating time in the following table so that the components are not destroyed by heat.

Tip temperatures for different soldering points:

Point to be soldered	Tip temperature
Surface-mounted (chip) parts [other than those shown below]	320 ± 30°C [heating time: less than 5 seconds]
Surface-mounted (chip) parts [for DVD cameras, cellular phones only]	350 ± 10°C [heating time: less than 3 seconds]
Discrete parts	380 ± 30°C
Chassis, metal shield, etc.	420 ± 30°C

### (4) Cautions when using lead based solder

It is recommended that you use lead-free solder when servicing, but it is also possible to service using lead based solder. However, if lead based solder is used for servicing, take care with the following:

- 1) Before using lead based solder, remove the lead-free solder completely from the point to be soldered.
- 2) For additional soldering for repair, set the soldering iron tip temperature for lead-free solder, mix lead based solder and lead-free solder sufficiently. Do not perform any repair using the bare soldering iron tip without adding solder, since it will cause secondary failure due to lack of strength.

## 1-6 Notes When Using Service Manual

### (1) Value units used in parts list

Certain symbols are indicated as shown below for value units of resistors, capacitors and coils in parts list. When you read them, note the following regular indications:

Parts	Indication in list	Regular indication
Resistor	KOHM .....	k $\Omega$
Capacitor	UF .....	$\mu$ F
	PF .....	pF
Coil	UH .....	$\mu$ H
	MH .....	mH

### (2) Values in schematic diagrams

The values, dielectric strength (power capacitance) and tolerances of the resistors (excluding variable resistors) and capacitors are indicated in the schematic diagrams using abbreviations. Certain symbols are indicated for value units: When you read them note the regular indications in tables below:

[Resistors]

Item	Indication
Value	No indication ..... $\Omega$
	K..... k $\Omega$
	M..... M $\Omega$
Tolerance	No indication ..... $\pm 5\%$ (All tolerances other than $\pm 5\%$ are indicated in schematic diagrams)
Power capacitance	No indication ..... 1/8W (1/16 W for leadless resistors with no indication) All capacitances other than the above are indicated in schematic diagrams.

[Capacitors]

Item	Indication
Value	No indication ..... $\mu$ F
	P ..... pF
Dielectric strength	No indication ..... 50V (All dielectric strengths other than 50 V are indicated in schematic diagrams)

[Coils]

Item	Indication
Value	$\mu$ ..... $\mu$ H
	m ..... mH

### (3) Identifying sides A/B in circuit board diagrams

1) Board with pattern on one side only and parts on both sides:

Side A: Shows discrete parts.

Side B: Shows leadless parts, viewed from the pattern side.

2) Board with patterns and parts on both sides:

Sides A and B are identified without any predetermined rules.

### (4) Indicating model names

The indication of models is defined as follows:

1) The common parts of model names are omitted.

Example: When indicating VM-D975LA and VM-D875LA:

VM-D975LA/D875LA, D975LA/D875LA

2) If there is no difference in models going to different destinations, the indication of destination is omitted.

Example: When indicating DZ-MV350E(AU) and DZ-MV350E(SW): DZ-MV350E



## 2 General Description

### 2-1 Overview

The HDD/DVD recorder models DV-DS253E and DS163E all incorporate 250-GB and 160-GB HDDs, made by Hitachi Global Storage Technologies.

The DVD recorder block contains a DVD multi-drive: It is compatible with recording and playback of a variety of media – 5x DVD-RAM, 4x DVD-RW, 16x DVD-R, 4x DVD+RW, 16x DVD+R and 8x DVD+R DL.

#### 2-1-1 Service method

Basically, components are replaced when servicing the HDD/DVD recorder. However, the service method is different for high-density packaging PCBs and precision components.

Refer to the following table and perform the designated, appropriate servicing. Any changes that occur in the service method will be published using service bulletin, etc.

Do not perform any servicing other than that described in this manual.

	Component	Service method
(a)	HDD	Unit replacement
(b)	TIMER-2 P.C.B	Component replacement
(c)	CARD P.C.B	Component replacement
(d)	DVD Drive Unit	Unit replacement
(e)	TIMER-1 P.C.B	Component replacement
(f)	MAIN P.C.B	Circuit board assembly replacement
(g)	HDMI P.C.B	Component replacement
(h)	I/O P.C.B	Component replacement
(i)	LOADER P.C.B	Component replacement
(j)	SMPS P.C.B	Component replacement
(k)	HDD P.C.B	Component replacement

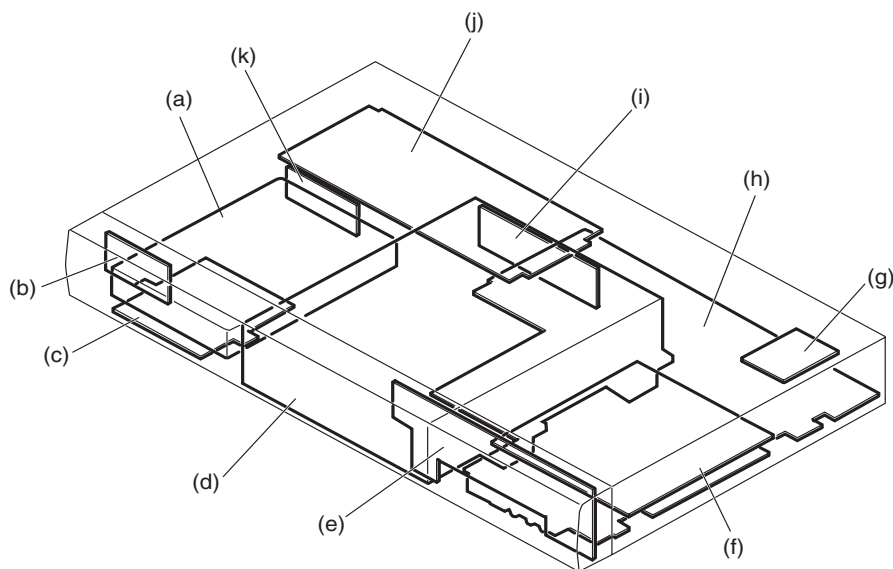

Fig. 2-1-1 Component Location

## 2-1-2 Disc information

### Recordable and Playable Discs

---



#### DVD-RAM

- DVD-RAM discs can be formatted for VR mode recording.
  - These Discs can be recorded on repeatedly. Recordings can be erased, then you can record again on the same Disc.
  - Playable on DVD-RAM compatible players.
  - Recordings can be extensively edited.
  - Only DVD-RAM standard Version 2.0, 2.1 and 2.2 discs can be used in this unit.
  - You cannot use the cartridge-type DVD-RAM disc in this unit.
- 



#### DVD-RW

- DVD-RW discs can be formatted for VR mode recording or Video mode recording.
  - These Discs can be recorded on repeatedly. Recordings can be erased, then you can record again on the same Disc.
- [VR mode]
- Recordings can be extensively edited
  - Playable only on VR mode compatible players (after finalization)
- [Video mode]
- Playable on regular DVD players (after finalization)
  - Limited editing features
- 



#### DVD-R

- These Discs can be recorded only once. After you finalize a DVD-R, you cannot record on it or edit it.
  - DVD-R discs can be only formatted to Video mode.
  - Playable on regular DVD players (after finalization).
  - Limited editing features
- 



#### DVD+RW

- These Discs can be recorded on repeatedly. Recordings can be erased, then you can record again on the same Disc.
  - Playable on DVD+RW compatible players (automatically finalization)
  - The edited contents are playable on DVD+RW compatible players only after finalization
  - Recordings can be edited the title/chapter
- 



#### DVD+R

- These Discs can be recorded only once. After you finalize a DVD+R, you cannot record on it or edit it any more.
  - Playable on DVD+R compatible players (after finalization)
  - Any edited contents are not be compatible on DVD+R compatible players. (Hide, chapter combine, added chapter mark, etc.)
  - Limited title/chapter editing features.
- 



#### DVD+R DL

- These Discs can be recorded only once. After you finalize a DVD+R DL, you cannot record on it or edit it any more.
  - Storage space is nearly doubled with double layer DVD+R media, allowing consumers to record up to 8.5GB of video on a single DVD+R DL disc.
  - Playable on DVD+R compatible players (after finalization)
  - Any edited contents are not be compatible on DVD+R DL compatible players. (Hide, chapter combine, added chapter mark, etc.)
  - Limited title/chapter editing features.
-

### The recordable DVD discs (Example)

DVD-RAM	DVD-RW	DVD-R	DVD+RW	DVD+R	DVD+R (DL)
Maxell (2x, 3x, 5x)	Maxell (1x, 2x, 4x)	Maxell (4x, 8x, 16x)	Maxell (2.4x, 4x)	Maxell (4x, 8x, 16x)	Maxell (2.4x)
Mitsubishi (2x, 3x)	Victor (1x, 4x)	Verbatim (4x, 8x)	SONY (4x)	Mitsubishi (4x, 8x, 16x)	Mitsubishi (2.4x, 8x)
Fujifilm (2x, 3x)	Verbatim (4x)	That's (8x, 16x)	Mitsubishi (4x)	Ricoh (2x, 4x, 8x, 16x)	—
—	Mitsubishi (2x, 4x)	—	Ricoh (2.4x, 4x)	Verbatim (8x)	—
—	—	—	—	—	—

**Note:**

If a DVD-RW/DVD+RW disc is recorded using a personal computer or other DVD recorder, you cannot format the disc using this recorder. So if you want to use the disc on this recorder, you must format the disc using the original recorder.

The above discs were checked for usability in 2006.

Disc specifications may be changed without notice.

### Playable Discs



**DVD (8 cm / 12 cm disc)**

- Discs such as movies that can be purchased or rented



**Video CD (VCD) (8 cm / 12 cm disc)**

- VIDEO CDs or CD-Rs/CD-RWs in VIDEO CD/Super VIDEO CD format



**Audio CD (8 cm / 12 cm disc)**

- Music CDs or CD-Rs/CD-RWs in music CD format that can be purchased



**CD-R/CD-RW (8 cm / 12 cm disc)**

- CD-R/CD-RW discs that contain audio titles, DivX<sup>®</sup>, MP3, WMA, or JPEG files.

**Notes:**

- Depending on the conditions of the recording equipment or the CD-R/RW (or DVD±R/RW) disc itself, some CD-R/RW (or DVD±R/RW) discs cannot be played on the unit.
- Images taken with a Hitachi DVD video camera on 8 cm DVD-R discs that have not been finalized can be played on the unit. Additional recording and finalization cannot be performed.
- Do not attach any seal or label to either side (the labeled side or the recorded side) of a disc.
- Do not use irregularly shaped CDs (e.g., heart-shaped or octagonal). Doing so may result in malfunctions.
- Depending on the recording software & the finalization, some recorded discs (CD-R/RW or DVD±R/RW) may not be playable.
- DVD-R/RW, DVD+R/RW and CD-R/RW discs recorded using a personal computer or a DVD or CD Recorder may not play if the disc is damaged or dirty, or if there is dirt or condensation on the Recorder's lens.
- If you record a disc using a personal computer, even if it is recorded in a compatible format, there are cases in which it may not play because of the settings of the application software used to create the disc. (Check with the software publisher for more detailed information.)

**Notes on DVDs and Video CDs**

Some playback operations of DVDs and Video CDs may be intentionally fixed by software manufacturers. As this unit plays DVDs and Video CDs according to disc content designed by the software manufacturer, some playback features of the unit may not be available or other functions may be added.

Refer also to the instructions supplied with the DVDs and Video CDs. Some DVDs made for business purposes may not be played on the unit.

## 2-2 Specifications

### General

Power requirements	AC 220-240V, 50/60 Hz
Power consumption	35W
Dimensions (approx.)	430 × 59 × 298 mm (w × h × d)
Mass (approx.)	4.1 kg
Operating temperature	5°C to 35°C
Operating humidity	10 % to 80 %
Television system	PAL B/G, SECAM L/L' colour system (253E/163E), PAL B/G, SECAM I/I' colour system (253E(UK)/163E(UK))
Recording format	PAL

### Recording

Recording format	DVD Video Recording, DVD-VIDEO
Recordable media	HDD, DVD-RAM, DVD-RW, DVD-R, DVD+RW, DVD+R, DVD+R (Double Layer)
Recordable time (DVD)	DVD (4.7GB): Approx. 1 hour (XP mode), 2 hours (SP mode), 4 hours (LP mode), 6 hours (EP mode) DVD+R DL (8.5GB): Approx. 1 hour 50 minutes (XP mode), 3 hours 30 minutes (SP mode), 7 hours 0 minutes (LP mode), 10 hours 30 minutes (EP mode)
Recordable time (HDD)	DV-DS253E HDD (250GB): Approx. 66 hours (XP mode), 129 hours (SP mode), 239 hours (LP mode), 338 hours (EP mode) DV-DS163E HDD (160GB): Approx. 48 hours (XP mode), 84 hours (SP mode), 156 hours (LP mode), 222 hours (EP mode)

#### Video recording format

Sampling frequency	27MHz
Compression format	MPEG 2 (VBR support)

#### Audio recording format

Sampling frequency	48kHz
Compression format	Dolby Digital

### Playback

Frequency response	DVD (PCM 48 kHz): 8 Hz to 20 kHz, CD: 8 Hz to 20 kHz DVD (PCM 96 kHz): 8 Hz to 44 kHz
Signal-to-noise ratio	More than 100 dB (AUDIO OUT connector)
Harmonic distortion	Less than 0.008 % (AUDIO OUT connector)
Dynamic range	More than 95 dB (AUDIO OUT connector)

### Inputs

AERIAL IN	Aerial input, 75 ohms
VIDEO IN	1.0 Vp-p 75 ohms, sync negative, RCA jack × 2 / SCART × 2
AUDIO IN	2.0 Vrms more than 47 kohms, RCA jack (L, R) × 2 / SCART × 2
DV IN	4 pin (IEEE 1394 standard)



### Outputs

VIDEO OUT	1 Vp-p 75 ohms, sync negative, RCA jack × 1 / SCART × 2
COMPONENT VIDEO OUT	(Y) 1.0 V (p-p), 75 ohms, negative sync, RCA jack × 1 (Pb)/(Pr) 0.7 V (p-p), 75 ohms, RCA jack × 2
HDMI video/audio output	19 pin (HDMI standard, Type A)
Audio output (digital audio)	0.5 V (p-p), 75 ohms, RCA jack × 1
Audio output (optical audio)	3 V (p-p), 75 ohms, Optical connector × 1
Audio output (analog audio)	2.0 Vrms (1 kHz, 0 dB), 600 ohms, RCA jack (L, R) × 1 / SCART × 2

- Design and specifications are subject to change without notice.

## 2-3 Major Differences from Previous Model

← : Same as on left

Item	DV-DS253E/DS163E	DV-DS251E/DS161E
Appearance		
Dimensions	430(W) x 298(D) x 59(H)mm	432(W) x 371.5(D) x 60.5(H)mm
Power consumption	Approx. 35 W	←
CPRM	Yes	←
Recordable media	DVD-RAM DVD-RW DVD-R DVD+RW DVD+R DVD+R DL	←
Playable media	DVD-RAM DVD-RW DVD-R DVD+RW DVD+R DVD+R DL CD-R/CD-RW (CD-DA, DivX, MP3, WMA, JPEG format)	←
HDD	DV-DS253E: 250GB	DV-DS251E: ←
	DV-DS163E: 160GB	DV-DS161E: ←
Remote control	DV-DS253E/DS163E: DV-RM253E DV-DS253E(UK)/DS163E(UK): DV-RM253E(UK)	DV-DS251E/DS161E: DV-RM251E DV-DS161E(UK): DV-RM251E(UK)
Memory card slot	For CF/MD/ST1 MD: x1 For SD/Mini SD/MMC/MMC Plus/ RS MMC/MMC Mobile/xD: x1	For CF/MD: x1 For SD/MMC/SMC/xD: x1
DV input terminal	x1 (IEEE 1394 standard)	←
S-Video input terminal	x1	←
Video/Audio input terminals	x4 (RCA: x2, SCART: x2)	←
Component video output terminal	x1 (RCA)	←
S-Video output terminal	Not provided	←
Video output terminal	x3 (RCA: x1, SCART: x2)	←
Analog audio output terminals	x3 (RCA: x1, SCART: x2)	←
Digital audio output terminals	x2 (Optical: x1, Coaxial: x1)	←
HDMI terminal	x1	←
Video out select switch	Provided	←

## 2-4 Function Differences from Previous Model

← : Same as on left

	Item	DV-DS253E/DS163E	DV-DS251E/DS161E
Recording	Recording Mode	4 mode (XP/SP/LP/EP)	←
	Time Shift	Provided	←
	Clip Recording	Provided	←
	Instant Timer Recording	Provided	←
	Timer Recording	Provided	←
	Recording from DV Input	Provided	←
Dubbing	HDD to DVD	Provided	←
	DVD to HDD	Provided	←
	One Touch Copy (HDD to DVD)	Provided	←
	One Touch Copy (DVD to HDD)	Provided	←
	FR (Flexible Recording) Mode	Provided	←
	Fast copying Mode	Provided	←
Title List	Adding Chapter Markers	Provided	←
	Changing Title Thumbnails	Provided	←
	Making a New Playlist	Provided	←
	Adding Title/Chapters	Provided	←
	Deleting Title/Chapter	Provided	←
	Deleting a Part	Provided	←
	Time Search	Provided	←
	Sort	Provided	←
	Combining Titles	Provided	←
	Divide	Provided	←
	Combining Chapters	Provided	←
	Moving a Playlist Chapter	Provided	←
	Hide a Chapter/Title	Provided	←
Playback	Displaying Disc Information	Provided	←
	Commercial Advance (CM Skip)	Not provided	Provided
	Random	Provided	←
	Repeat A-B	Provided	←
	Time Search	Provided	←
	Zoom	Provided	←
	Marker Search	Provided	←
	Manual Skip	Provided (15 second)	←
	DivX Movie File Playback	Provided	←
	Audio CD Playback	Provided	←
	MP3 Playback	Provided	←
	WMA file Playback	Provided	←
	JPEG File Viewing	Provided	←
P in P	Not provided	←	

## 2-5 Names of Parts

### Front Panel

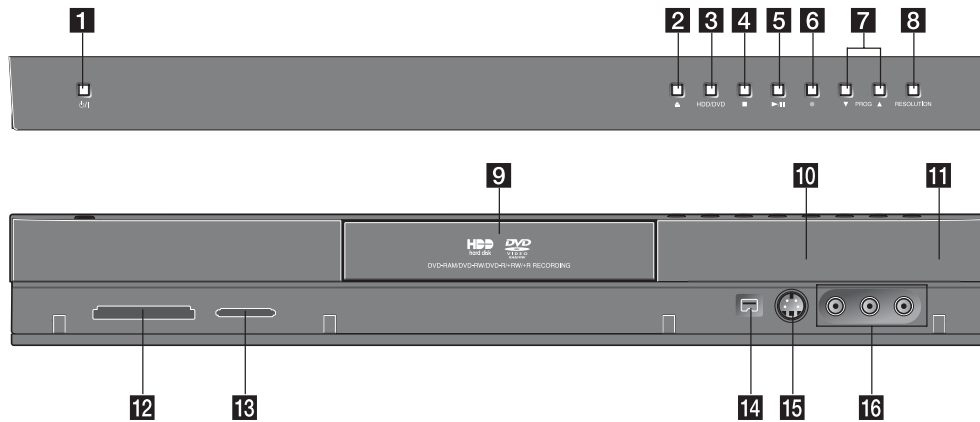

- 1 POWER button**  
Switches the recorder ON or OFF.  
(As to the indication of the Operate switch, “ I ” shows ON and “⏻” shows electrical power stand-by.)
- 2 ▲ (OPEN/CLOSE)**  
Opens or closes the disc tray.
- 3 HDD/DVD**  
Set the recorder’s mode to HDD or DVD.
- 4 ■ (STOP)**  
Stops playback or recording.
- 5 ► / II (PLAY/PAUSE)**  
Starts playback.  
Pause playback or recording temporarily, press again to exit pause mode.
- 6 ● (REC)**  
Starts recording. Press repeatedly to set the recording time.
- 7 PROG. (▼ / ▲)**  
Scans up or down through memorized channels.
- 8 RESOLUTION**  
Sets the output resolution for HDMI and COMPONENT/PROGRESSIVE SCAN VIDEO OUT jacks.  
– HDMI: 576i, 576p, 720p, 1080i  
– COMPONENT: 576i, 576p
- 9 Disc Tray**  
Insert a disc here.

- 10 Display window**  
Shows the current status of the recorder.  
**T/S**: Indicates the timeshifting mode.  
**REC**: The recorder is recording.  
**HDD**: The recorder is HDD mode.  
**DVD**: The recorder is DVD mode.  
**HDD ◀▶ DVD**: The recorder is dubbing.  
**TV**: Indicates when the recorder is in TV tuner mode.  
⌚ : Indicates when the recorder is in timer recording or a timer recording is programmed.  
⏱ : Indicates clock, total playing time, elapsed time, title number, chapter/track number, channel, etc.
- 11 Remote Sensor**  
Point the recorder remote control here.
- 12 MEMORY CARD Slot 1**  
Insert a memory card (CF/MD/ST1 MD).
- 13 MEMORY CARD Slot 2**  
Insert a memory card (SD/Mini SD/MMC/MMC Plus/RS MMC/MMC Mobile/xD).
- 14 DV IN**  
Connect the DV output of a digital camcorder.
- 15 INPUT 4 (S-VIDEO IN)**  
Connect the S-Video output of an external source (TV/ Monitor, VCR, Camcorder, etc.).
- 16 INPUT4 (VIDEO IN/AUDIO IN (Left/Right))**  
Connect the audio/video output of an external source (Audio system, TV/ Monitor, VCR, Camcorder, etc.).

**Note:**

The **2** ▲ (OPEN/CLOSE) button will not operate with this recorder turned off. After turning the recorder on to display the clock in the **10** Display window, press the **2** ▲ (OPEN/CLOSE) button.

## Remote Control

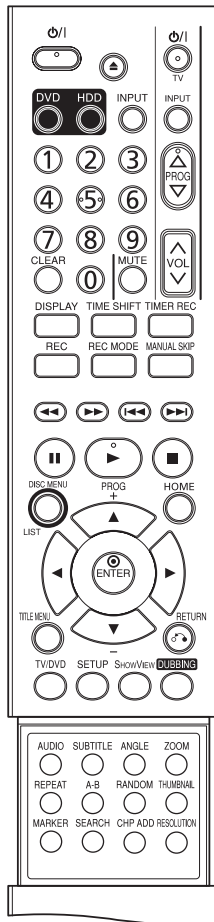

### 0-9 numerical buttons:

Selects numbered options in a menu.

◀ / ▶ / ▲ / ▼ (left/right/up/down): Selects an option in the menu.

▲ / ▼ (up/down): Scans up or down through memorized channels.

**A-B:** Repeat sequence.

**ANGLE:** Selects a DVD camera angle, if available.

**AUDIO:** Selects an audio language (DVD) or TV audio channel (CD).

**CHP ADD:** Inserts a chapter marker when playing/recording.

**CLEAR:** Removes a track number on the Program List or a mark on the Marker Search menu.

### DISC MENU/LIST:

Accesses menu on a DVD disc. Switches between Title List-Original and Title List-Playlist menu.

### DISPLAY:

Accesses On-Screen Display.

**DUBBING:** Copies DVD to HDD (or HDD to DVD).

**DVD:** Select the Recorder's function mode to DVD.

### ENTER

- Acknowledges menu selection.
- Displays information while viewing a TV program.

**HDD:** Select the Recorder's function mode to HDD.

**HOME:** Accesses or removes the HOME menu.

**INPUT:** Changes the input to use for recording (Tuner, AV1-4 or DV IN).

### MANUAL SKIP:

Pressing this button during playback will skip to a scene 15 seconds forward.

**MARKER:** Marks any point during playback.

### ▲ (OPEN/CLOSE):

Opens and closes the disc tray. Operate this button only after turning the recorder on.

### II (PAUSE/STEP):

Pause playback or recording temporarily, press again to exit pause mode.

### ▶ (PLAY):

Starts playback.

### ⏻/⏿ POWER:

Switches the recorder ON or OFF.

### RANDOM:

Plays tracks in random order.

### ● (REC):

Starts recording. Press repeatedly to set the recording time.

**REC MODE:** Selects the recording mode (XP, SP, LP or EP).

### REPEAT:

Repeat chapter, track, title, all.

### RESOLUTION:

Sets the output resolution for HDMI.

### RETURN (↶):

- Removes the menu.
- Display the menu of a video CD with PBC.

### ◀◀ / ▶▶ (SCAN):

Search backward or forward.

### SEARCH:

Displays Marker Search menu.

**SETUP:** Accesses or removes the Setup menu.

**SHOWVIEW:** To display the program menu for SHOWVIEW System programming.

### ◀◀ / ▶▶ (SKIP):

Go to next chapter or track. Returns to beginning of current chapter or track or go to previous chapter or track.

### ■ (STOP):

Stops playback or recording.

### SUBTITLE:

Selects a subtitle language.

**THUMBAIL:** Selects a thumbnail picture for the current title and chapter for use in the Original and Playlist menu.

### TIMER REC:

Displays Timer Record menu.

**TIMESHIFT:** Activates pause live TV/playback (timeshift) for a live TV program.

### TITLE MENU:

Displays the disc's Title menu, if available.

### TV/DVD:

To view channels selected by the recorder tuner or by the TV tuner.

### TV Control Buttons

- POWER: Turns the TV on or off.
- INPUT: Selects the TV's source.
- PROG +/-: Selects TV's channel.
- VOL +/-: Adjusts TV's volume.
- MUTE: Temporarily turns TV sound OFF, press again to restore.

### ZOOM:

Enlarges DVD video image.



## Rear Panel

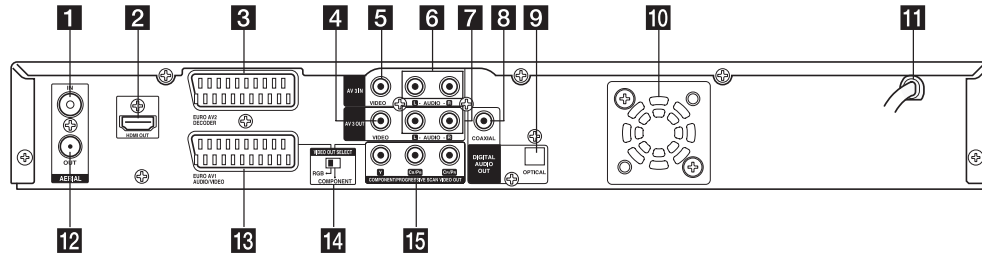

**1 AERIAL**

Connect the aerial to this terminal.

**2 HDMI Connector (Type A)**

HDMI output providing a high quality interface for digital audio and video.

**3 EURO AV 2 DECODER**

Connect the audio/video output of an external source (Pay-TV decoder, Set Top Box, VCR, etc.).

**4 AV 3 (VIDEO) OUT**

Connect to a TV with video inputs.

**5 AV 3 (VIDEO) IN**

Connect the video output of an external source (Audio system, TV/Monitor, VCR, Camcorder).

**6 AV 3 (AUDIO) IN (Left/Right)**

Connect the audio output of an external source (Audio system, TV/Monitor, VCR, Camcorder).

**7 AV 3 (AUDIO) OUT (Left/Right)**

Connect to a TV with audio inputs.

**8 COAXIAL (Digital audio out jack)**

Connect to digital (coaxial) audio equipment.

**9 OPTICAL (Digital audio out jack)**

Connect to digital (optical) audio equipment.

**10 Cooling fan**

**11 AC Power Cord**

Plug into the power source.

**12 RF. OUT**

Passes the signal from the AERIAL to your TV/monitor

**13 EURO AV 1 AUDIO/VIDEO**

Connect to a TV with SCART jack.

**14 VIDEO OUT SELECT Switch**

Select either COMPONENT VIDEO OUT or RGB signal of EURO AV1 AUDIO/VIDEO terminal depending on how you connect the recorder to the TV.

**15 COMPONENT/PROGRESSIVE SCAN VIDEO OUT (Y Pb Pr)**

Connect to a TV with Y Pb Pr inputs.

## 2-6 HDMI Connection

If you have a HDMI TV or monitor, you can connect it to this recorder using a HDMI cable.

Be sure to use an HDMI cable with HDMI logo (**HDMI**).

1. Connect the HDMI jack on the recorder to the HDMI jack on a HDMI compatible TV or monitor (H).
2. Set the TV's source to HDMI (refer to TV's Owner's manual).

### Tip:

When you use HDMI connection, you can change the resolution (576i, 576p, 720p, or 1080i) for the HDMI output using RESOLUTION button.

Press the RESOLUTION button once to show the current setting in the display window on the front of the unit. Pressing the RESOLUTION button again within about 2 seconds switches the resolution setting in the following order: 576i→576p→720p→1080i.

- When the resolution is set to 720p or 1080i, the TV Aspect setting on the Setup menu is fixed at "16:9".

### ⚠ Caution

- Some TVs with HDMI interface do not support "Progressive Scan OFF mode: 576i". If no image appears when the HDMI connectors on recorder and the TV are joined, connect the analog VIDEO OUT jack to the video input on TV, in order to display the image through the recorder. Then press the RESOLUTION button on the front of the unit repeatedly until the image appears.
- Changing the resolution when the recorder is connected with HDMI connector may result in malfunctions. To solve the problem, turn off the recorder and then turn it on again.

### Notes

- If your TV is NOT capable of handling 96 kHz sampling frequency, set the [Sampling Freq.] option to [48 kHz] on the setup menu.  
When this choice is made, this unit will automatically convert any 96 kHz signals to 48 kHz so your system can decode them.
- If your TV is not equipped with Dolby Digital and MPEG decoder, set the [Dolby Digital] and [MPEG] options to [PCM] on the setup menu.
- If your TV is not equipped with DTS decoder, set the [DTS] options to [OFF] on the setup menu.  
To enjoy DTS multi channel surround, you must connect this recorder to a DTS compatible receiver via one of this recorder's digital audio outputs.
- The arrow on the cable connector body should face up for correct alignment with the connector on the recorder.

- If there is noise or lines on the screen, please check the HDMI cable.

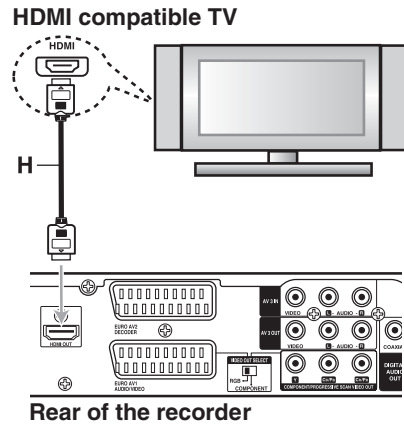

### About HDMI

HDMI (High Definition Multimedia Interface) supports both video and audio on a single digital connection for use with DVD Players, Set-Top Boxes, and other AV devices.

HDMI was developed to provide the technologies of HDCP (High-bandwidth Digital Content Protection). HDCP is used to protect digital content transmitted and received.

HDMI has the capability to support standard, enhanced, or high-definition video plus standard to multi-channel surround-sound audio, HDMI features include uncompressed digital video, a bandwidth of up to 5 gigabytes per second, one connector (instead of several cables and connectors), and communication between the AV source and AV devices such as DTVs.

*HDMI, the HDMI logo and High-Definition Multimedia Interface are trademarks or registered trademarks of HDMI licensing LLC.*

### Additional Information for HDMI

- When you connect a HDMI or DVI compatible device make sure of the followings:
  - Try switching off the HDMI/DVI device and this recorder. Next, switch on the HDMI/DVI device and leave it for around 30 seconds, then switch on this recorder.
  - The connected device's video input is set correctly for this unit.
  - The connected device is compatible with 720(1440)×576i, 720×576p, 1280×720p, or 1920×1080i video input.
- Not all HDCP-compatible DVI devices will work with this recorder.
  - It's impossible copy protected-DVD title's playback in non-HDCP devices.

## 2-7 List of Abbreviations and Terms for DVD Recorder

Index	Abbreviation/Term	Explanation
A	AC3	See Dolby AC3.
B	Black Level	Function to correct the gradations on dark portions to make dark scenes easier-to-see.
C	CPRM	Content Protection for Recordable Media: Copyright protection function that is suitable for online distribution of music.
	CD-R	One type of DVD standard disc, to which writing once is possible (recordable type)
	CD-RW	One type of CD standard disc, to which writing up to 1000 times is possible
	Component video output terminals	Used for outputs of HDTV video signal format. Since signals for brightness and colors are independently handled for components signals (Y: luminance signal; PR/PB: chrominance signals), degrading of image will be reduced.
D	Decoder	A device that decodes the data coded and recorded on DVD Video and restores it to video and audio signals. This processing is referred to as decoding.
	Dynamic Range	A difference between maximum and minimum levels of audio recorded on disc: Measured in decibel (dB) units. If the dynamic range is compressed (audio DRC), the minimum signal level will increase and the maximum signal level will decrease: This will reduce the higher audio signal - such as burst sound - so that the low-level audio signal - such as human voice - can be heard more clearly.
	Dolby AC3	Audio coding format developed by Dolby Laboratories in U.S, also simply referred as AC3 format: Supports 5-channel full-range sound and one channel for sub-woofer sound playback.
	DRC	Dynamic Range Control: Adjusting the audio range of maximum and minimum levels (dynamic range) will improve audio signal when, for example, dialog is hard to hear or user is watching movies late at night.
	DTS	Digital Theater System: Sound system as for movie theaters developed by US Digital Theater Systems, Inc. The number of channels provided by DTS is the same for Dolby AC3.
	DVD	Digital Versatile Disc. A huge amount of digital data for video (movie) and audio can be recorded on this disc, whose size is the same as CD.
	DVD-Audio	One type of DVD standard disc, on which high-quality audio can be recorded
	DVD-R	One type of DVD standard disc, to which writing once is possible (recordable type)
	DVD-RAM	One type of DVD standard disc, to which writing up to 100,000 times is possible
	DVD-RW	One type of DVD standard disc, to which writing up to 1000 times is possible
	DVD-Video	One type of DVD standard disc, on which high-quality video and audio can be recorded
	DVD Video Format	Video recording/playback standard that applies to DVD-Video, DVD-R and DVD-RW
	DVD Video Recording Format	Video recording/playback standard that applies to DVD-RAM and DVD-RW: This allows versatile editing functions, differing from the DVD Video Format.
H	HDMI	High-Definition Multimedia Interface: A digital video/audio input/output interface standard, mainly applied to home electronics and AV devices. The specifications of DVI (Digital Visual Interface), the display connection technology, were compiled for AV devices. Although multiple cables for video, audio and control signals were previously necessary to connect devices, only one cable is needed with HDMI.

Index	Abbreviation/Term	Explanation
I	I/P/B	DVD recorders normally use data that is common between images, and individually record different data for each image. I-picture: Images recorded independently for the reference of commonly used data. P-picture: Images created from past I-picture or P-picture B-picture: Images created from both I and P pictures, which interact between both types Since I-picture delivers the highest image quality, selecting I-picture is recommended when adjusting image quality.
J	JPEG	Joint Photographic Expert Group: International standard format for compressing still images.
M	MPEG	Moving Picture Experts Group: Standard related to compression of digital video and audio. MPEG2 is a higher standard of MPEG and is applied to video (movie) requiring higher quality.
	MPEG Audio Layer 2	One of three audio compression standards (layers 1-3) defined by MPEG
	MP3	MPEG1 Audio Layer-3: Audio data digital compression technology.
O	Optical digital audio output	Audio is usually converted to an electrical signal and transmitted from DVD to a device such as amp: When audio is converted to a digital signal, this optical digital audio output can be transmitted on optical fiber.
P	Pan & Scan/ Letterbox	Most DVD videos are produced assuming that they will be displayed on wide TV screen (aspect ratio of 16:9): If they are displayed on TV screens with 4:3 aspect ratio, 16:9 images will not quite fit on 4:3 screens. There are two ways of displaying 16:9 images on 4:3 TV: · Pan & Scan: Cuts out the left and right ends of images and displays them on whole screen. · Letterbox: Reproduces 16:9 images on 4:3 screens with black bands across the top and bottom of screen.
	Playback Control (PBC)	One format to play Video CD: User can select desired screens and data while watching the displayed menu screen.
	Progressive playback function	This function converts interlaced images to non-interlaced images and displays them. It can play back 24-frame/second images included in DVD movie software, etc.
S	S-Video Output	The video signal is separated into chrominance (C) and luminance (L) signals and transmitted to TV: This delivers clearer images.
	Sampling Frequency	Sampling slices audio waves (analog signal) at a specified time interval, and digitizes the levels of the sliced waves. The slicing number per second is referred to as the sampling frequency: The higher the number, the closer the sound to the original.
W	WMA	Windows Media Audio: Codec that was developed by Microsoft Corporation in USA.
Num.	3D surround	This technology localizes sound at any position using only two front speakers, by subjecting the L and R signals to matrix operation. It uses the four transfer functions from L/R speakers located at specified positions to both ears of listener located in a specified position, taking into account the shape of head and the effect of earlobes, and the two transfer functions from any position to both ears.

## 3 Details of Servicing and Troubleshooting

### 3-1 How to Remove Disc from Faulty Recorder

- 1) Open the front lid (a).
- 2) Insert a pin (b) into the eject hole (c), and then press the lever in the direction of the arrow.
- 3) The disc lid (d) will open, and the disc tray (e) will come out a few millimeters.
- 4) Hold the both left and right ends of disc tray and pull out the tray in the direction of the arrow.

- (a) Front Lid
- (b) Pin (an extended clip, etc)
- (c) Eject Hole
- (d) Disc Lid
- (e) Disk Tray

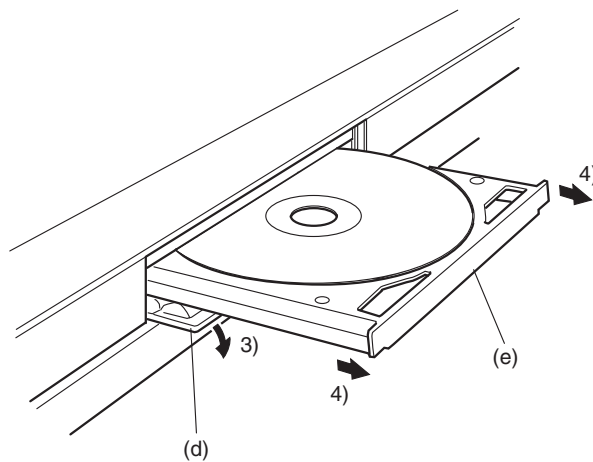
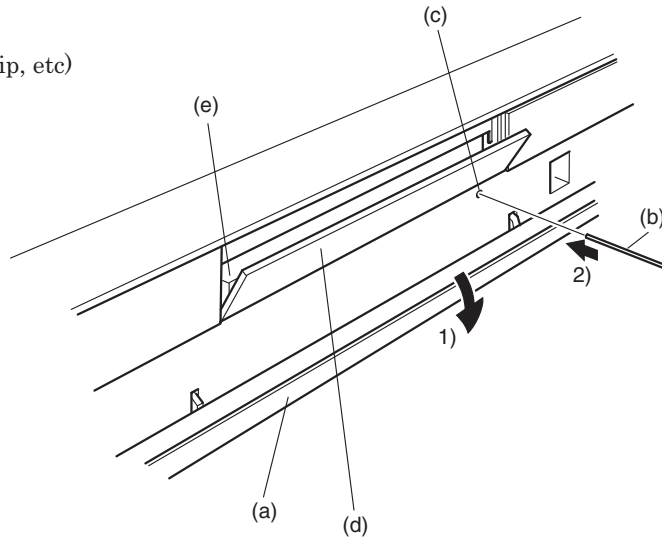

Fig. 3-1-1 Removing Disc

## 3-2 Initialization

### Information:

All this procedure can be executed by operating the buttons on remote control: Prepare the remote control.

### 3-2-1 Factory Set

Execute Factory Set to return the items that have been set after unpacking to the factory defaults.

- 1) Press the SETUP button on remote control.
- 2) Use the cursor up and down buttons to choose “Initialization” and press the cursor right button.
- 3) Use the cursor up and down buttons to choose “Factory Set” and press the ENTER button.
- 4) Follow the instructions on screen hereafter to return the various settings to the factory defaults.

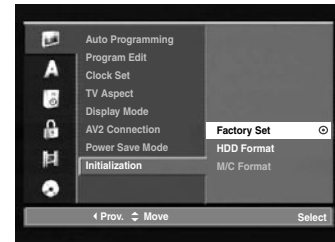

Fig. 3-2-1 Factory Set

### 3-2-2 HDD Format

Execute HDD Format to delete all recorded data on HDD.

Be sure to execute this item after replacing a HDD so that the new HDD will be usable.

- 1) Press the SETUP button on remote control.
- 2) Use the cursor up and down buttons to choose “Initialization” and press the cursor right button.
- 3) Use the cursor up and down buttons to choose “HDD Format” and press the ENTER button.
- 4) Follow the instructions on screen hereafter to format the HDD.

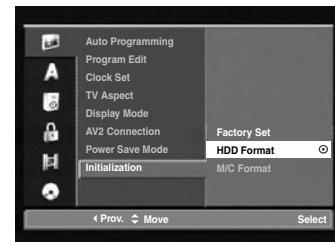

Fig. 3-2-2 HDD Format

### 3-3 Troubleshooting HDD

This section shows how to determine a fault in HDD and how to format a new HDD to replace the faulty HDD.

#### (1) HDD troubleshooting method

If the playback picture temporarily stops or distortion occurs frequently, the HDD may be faulty. If this happens, observe the defective phenomenon, decide whether the HDD is faulty, and then repair or replace the HDD.

When replacing the HDD, note that the data on the old HDD cannot be transferred to a new HDD.

**Information:**

When discarding a faulty HDD, physically destroy it or perform procedure as required, according to the regulations in each country, in order to protect any personal information.

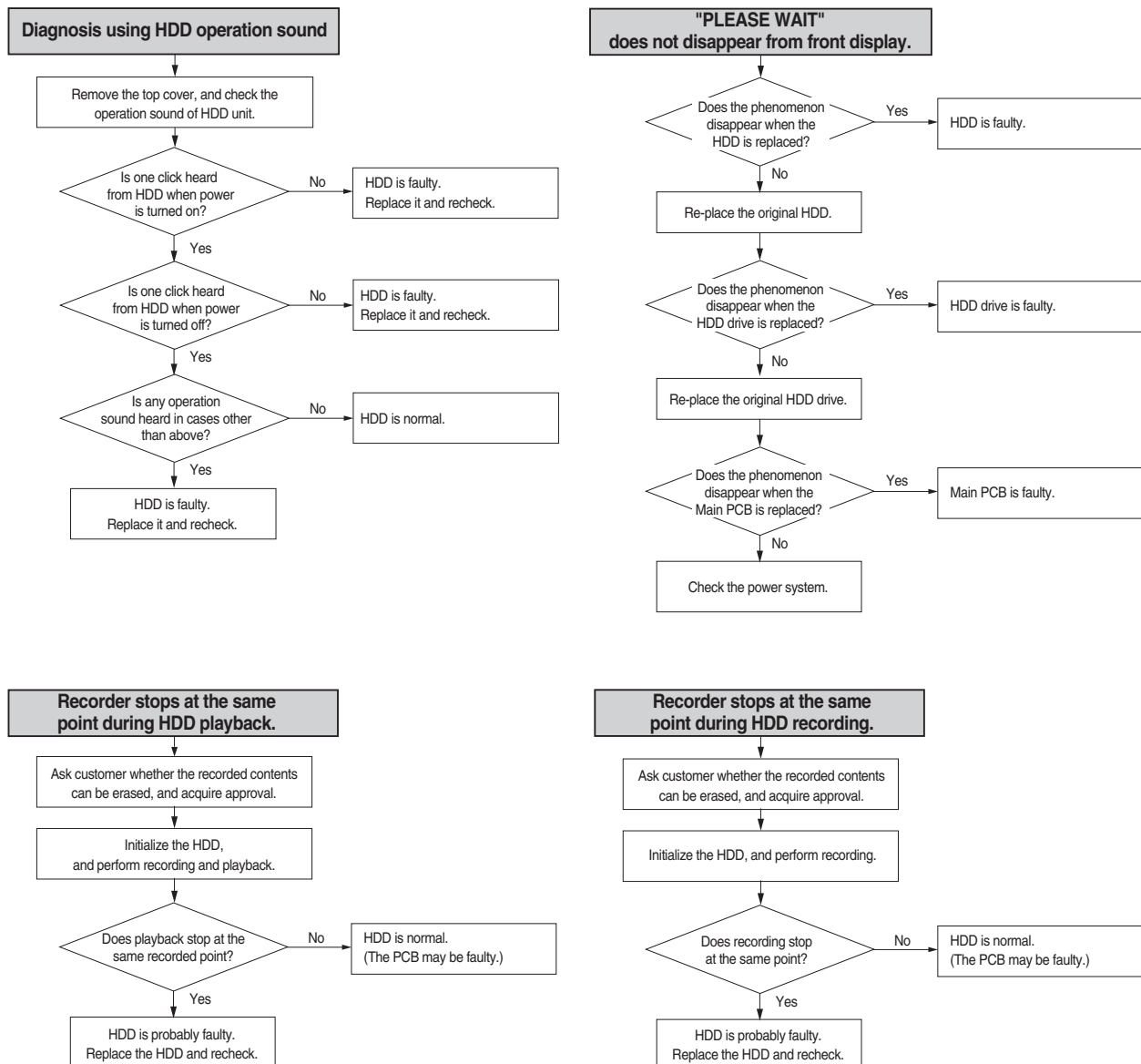

## 3-4 Checking Versions of Firmware and Updating

The firmware is occasionally updated to improve performance.

Check whether a customer complaint can be solved by updating of firmware: If the complaint can be solved, update the firmware.

### Information:

If any corrections in firmware are made at the factory, information on how to obtain the firmware data and create a disc containing upgraded firmware will be reported in technical bulletin, etc.

### 3-4-1 Version check procedure

- 1) With the HDD/DVD recorder turned on, make sure that no disc is inserted.
- 2) Connect a monitor TV to the video output terminals on this HDD/DVD recorder.
- 3) Press the SETUP button on remote control and use the cursor up and down buttons to choose the “LOCK” menu (Fig. 3-4-1).
- 4) Press numeric buttons “7” “8” “8” “9” on the remote control in sequence.
- 5) The firmware version screen will appear on the monitor TV (Fig. 3-4-2).
- 6) Turn the HDD/DVD recorder off to switch off the display.



Fig. 3-4-1



Fig. 3-4-2

### 3-4-2 Method of starting up firmware update program

- 1) Turn the HDD/DVD recorder on and press the OPEN/CLOSE button.
- 2) Insert the firmware disc.
- 3) Press HOME button on the remote control to display the Home Menu screen (Fig. 3-4-3).
- 4) Select the [MOVIE]. Options appear.
- 5) Select the [DISC] and press the ENTER button: The screen for verifying update will appear (Fig. 3-4-4).
- 6) Select the [YES] and press the ENTER button: The firmware update program will start up. The screen for verifying update will appear.



Fig. 3-4-3



Fig. 3-4-4



### 3-4-3 Main firmware updating procedure

#### (1) To make Main firmware updating CD

- 1) Store the Main firmware data in PC.
- 2) Start a CD writer program, and drag the Main firmware data file (write it to the Root folder on CD).
- 3) Check the file name (LG\_HDR\_UPDATE.004). If it is incorrect, rename it.
- 4) Change the volume name of CD to RH1000\_UP.
- 5) Write the Main firmware data to a CD-R or CD-RW.

#### (2) To update main firmware

- 1) Refer to “3-4-2 Method of starting up firmware update program” and start the firmware update program: Once the firmware update program has started, the screen in Fig. 3-4-5 will appear.

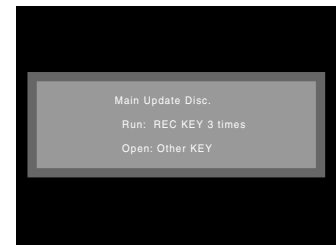

Fig. 3-4-5

- 2) Press the REC button on this HDD/DVD recorder three times: Both the current version of main firmware and the version of main firmware on the disc will appear on the screen (Fig. 3-4-6).

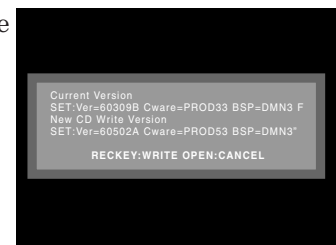

Fig. 3-4-6

- 3) Pressing the REC button on this HDD/DVD recorder will start writing (Fig. 3-4-7). To cancel writing, press the OPEN/CLOSE button and remove the disc.
- 4) When updating is complete, the tray will open automatically: Remove the disc.
- 5) Turn the HDD/DVD recorder off and then on: The firmware is now updated.

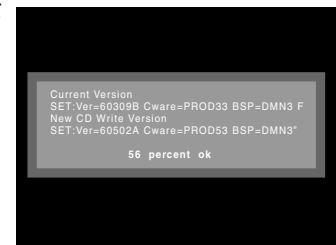

Fig. 3-4-7

### 3-4-4 Loader firmware updating procedure

#### (1) To make loader firmware updating CD

- 1) Store the loader firmware data in PC, and decompress it: Three files (prm, bin, bin) will appear.
- 2) Start a CD writer program, and drag the three loader firmware data files (write them to the Root folder on CD).
- 3) Change the volume name of CD to DRIVE\_UP.
- 4) Write the loader firmware data to a CD-R or CD-RW.

#### (2) To update loader firmware

- 1) Refer to “3-4-2 Method of starting up firmware update program” and start the firmware update program: Once the firmware update program has started, the screen in Fig. 3-4-8 will appear.
- 2) Press the REC button on this HDD/DVD recorder three times: The data on disc will be read, the Firmware Update screen will appear, and the loader firmware version along with the version of loader firmware on the disc, will appear on the screen (Fig. 3-4-9). When reading the data on disc is complete, the disc tray will open automatically: Remove the disc.
- 3) Pressing the REC button on this HDD/DVD recorder will start writing. To cancel writing, press the OPEN/CLOSE button.
- 4) Turn the HDD/DVD recorder off automatically.

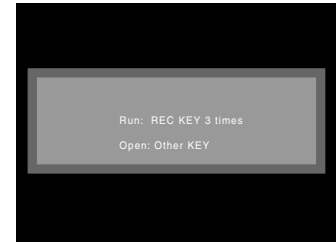

Fig. 3-4-8

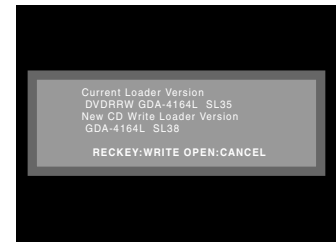

Fig. 3-4-9

### 3-4-5 Main/Loader firmware simultaneous updating procedure

#### (1) To make firmware updating CD

- 1) Start a CD writer program, and drag the main and loader firmware data files (write them to the Root folder on CD).
- 2) Change the volume name of CD to RH1000\_UP.
- 3) Write the main and loader firmware data to a CD-R or CD-RW in the “Track at once” mode.

#### (2) To update firmware

- 1) Refer to “3-4-2 Method of starting up firmware update program” and start the firmware update program: Once the firmware update program has started, the screen in Fig. 3-4-10 will appear.
- 2) Press the REC button on this HDD/DVD recorder three times: The screen for choosing the firmware programs to be updated will appear: Choose “All” (Fig. 3-4-11).
- 3) The method of simultaneously updating the Main/Loader firmware programs is basically the same as that for updating individual programs.

After the Main firmware is updated, the Loader firmware updating screen will automatically appear.

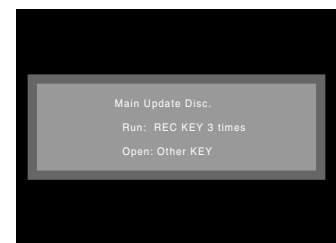

Fig. 3-4-10

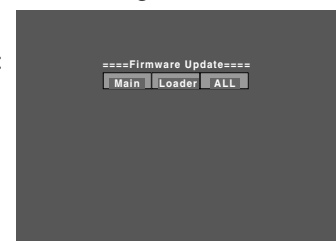
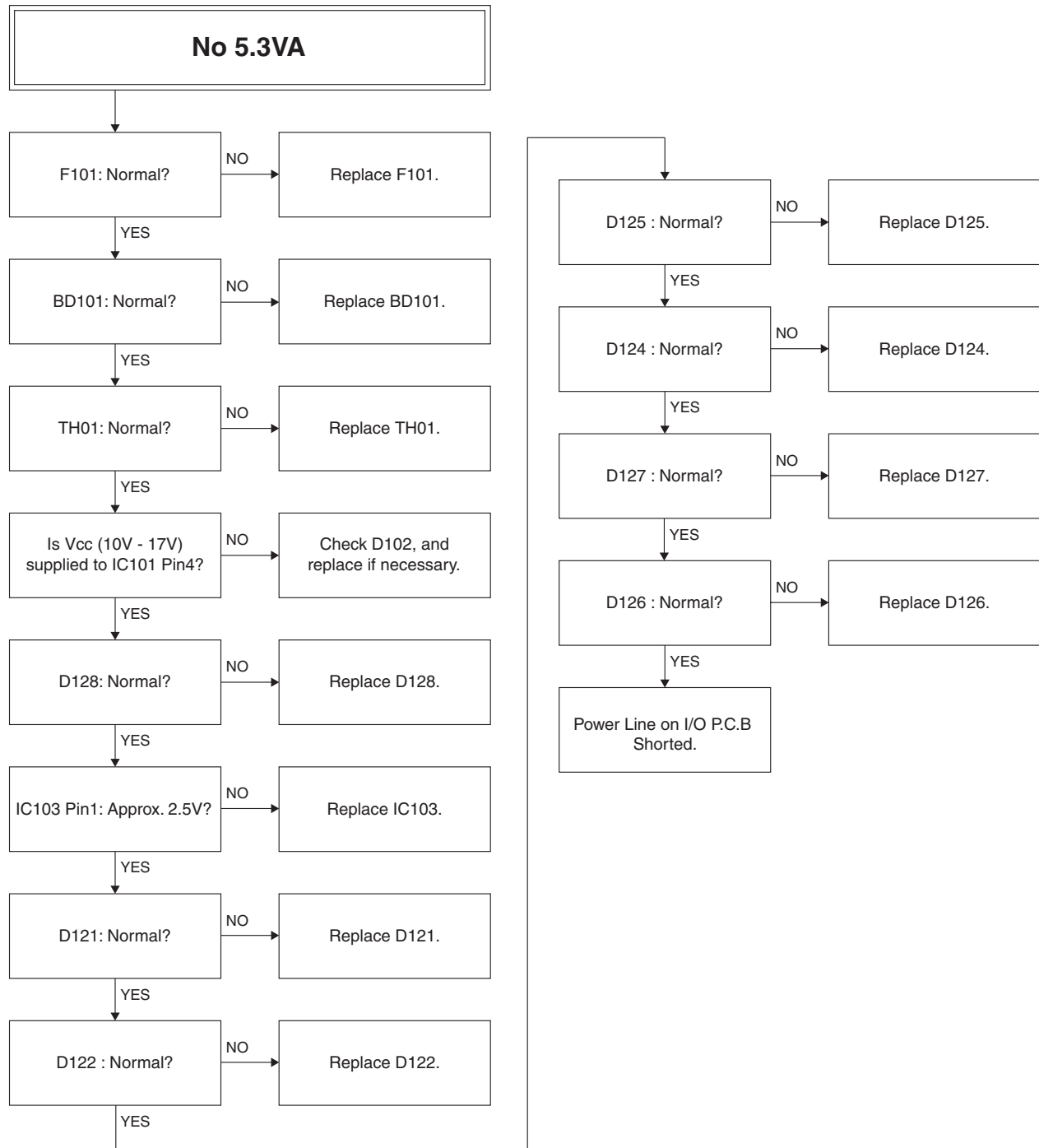

Fig. 3-4-11

## 3-5 Troubleshooting

### 3-5-1 Troubleshooting electronic system

#### (1) SMPS Circuit (on SMPS P.C.B)



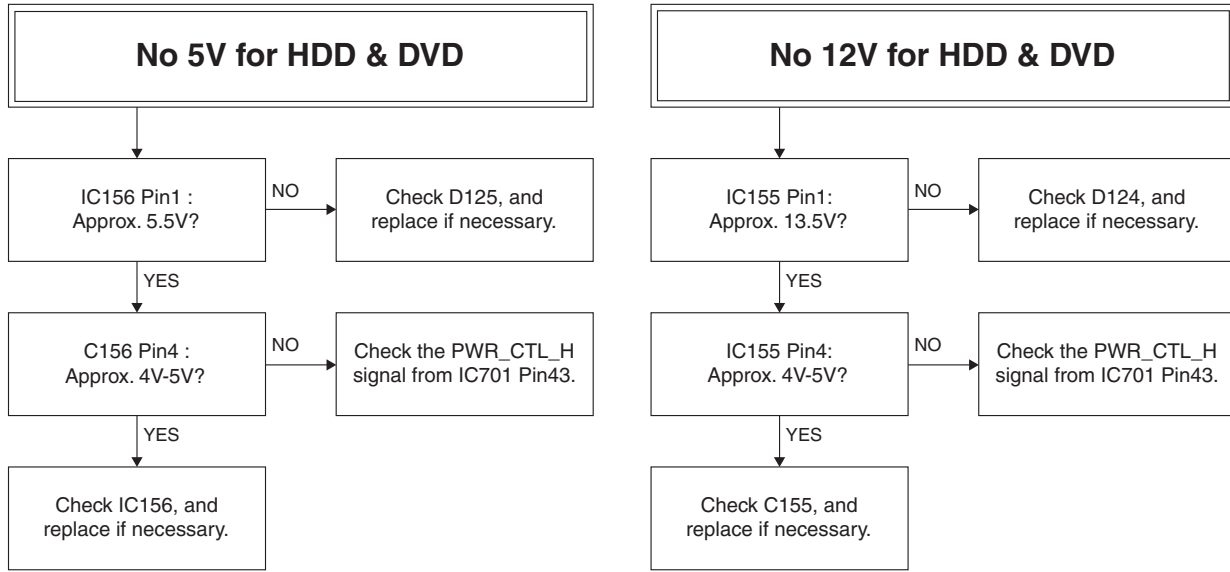

**(2) SMPS Circuit (on I/O P.C.B)**

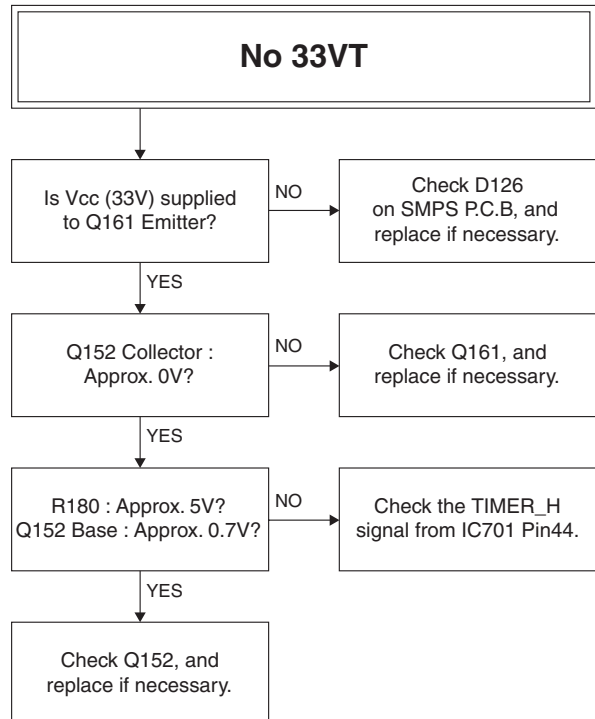
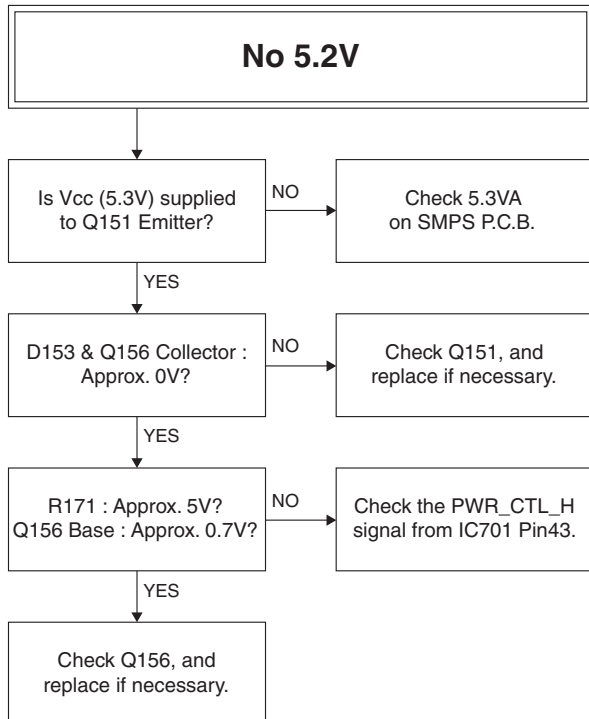
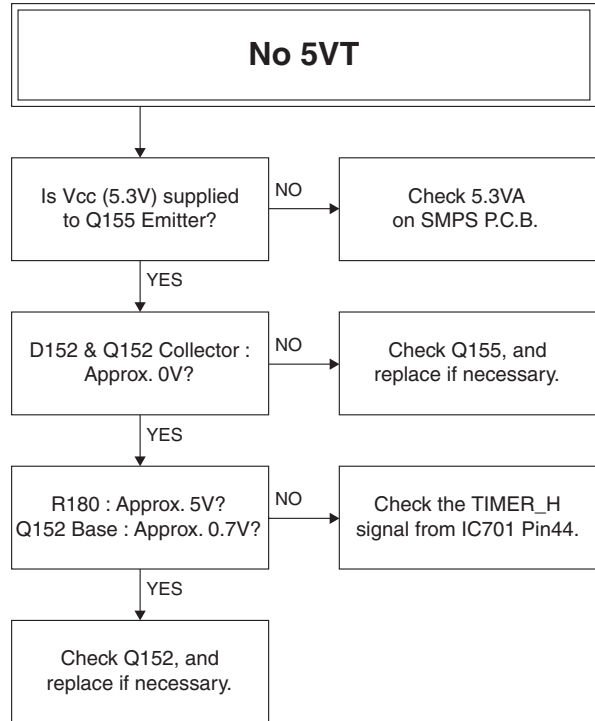
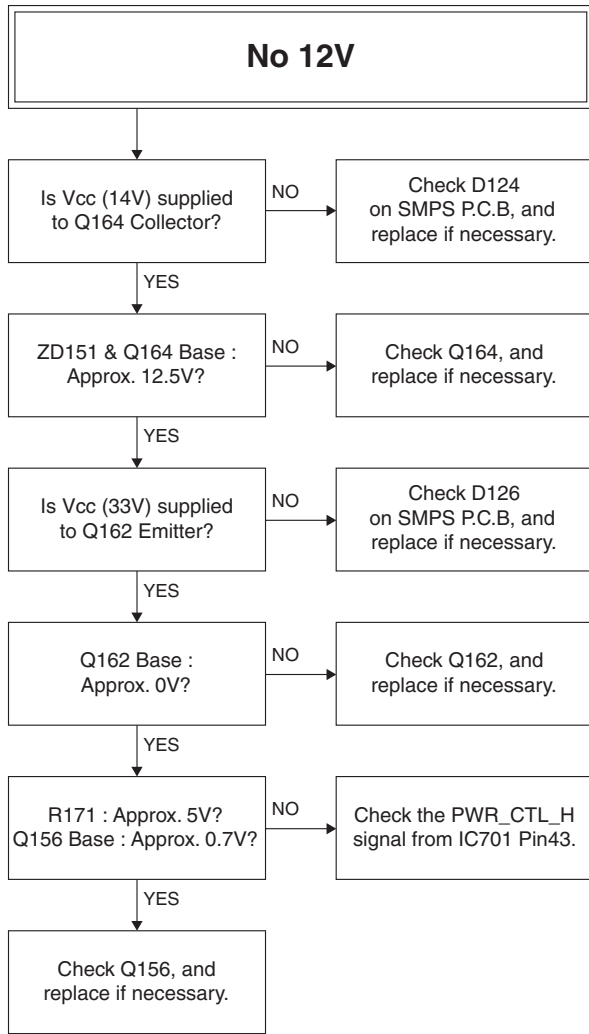

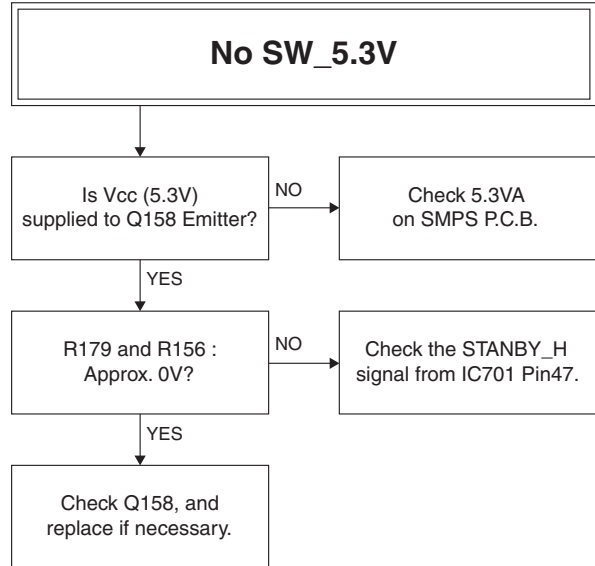
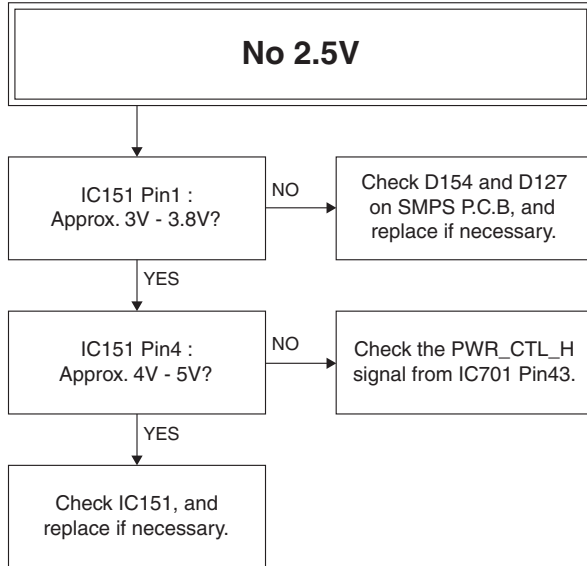
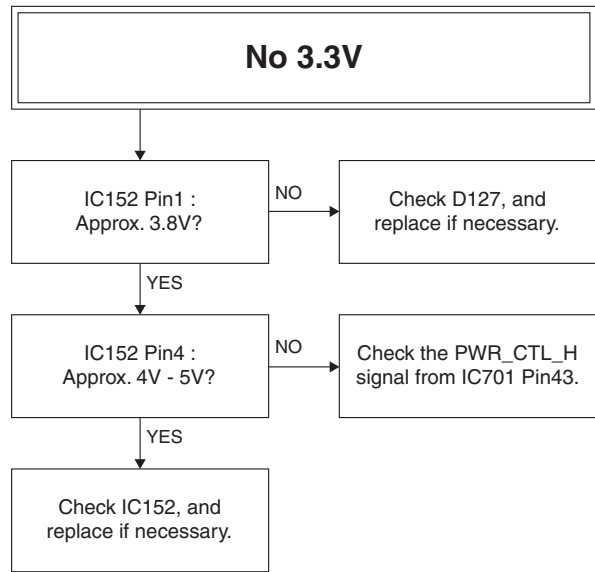
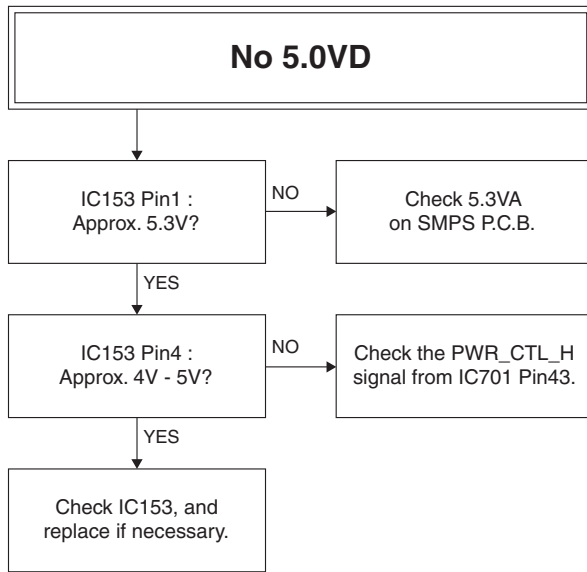

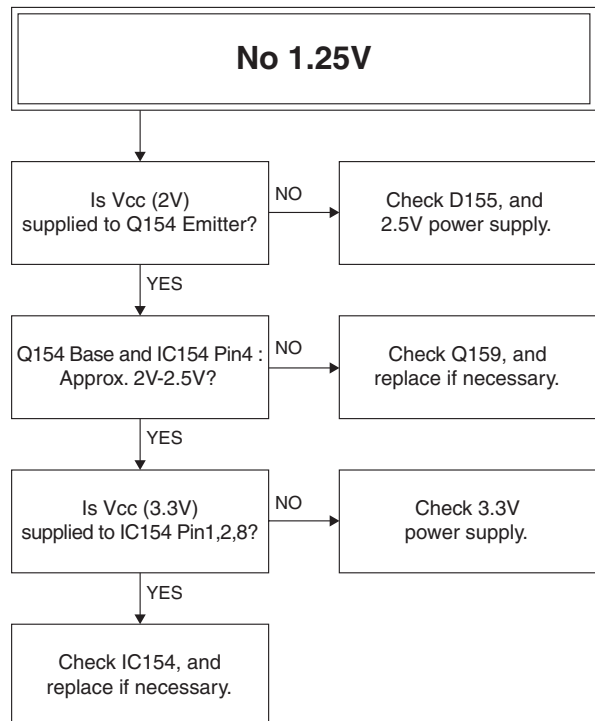
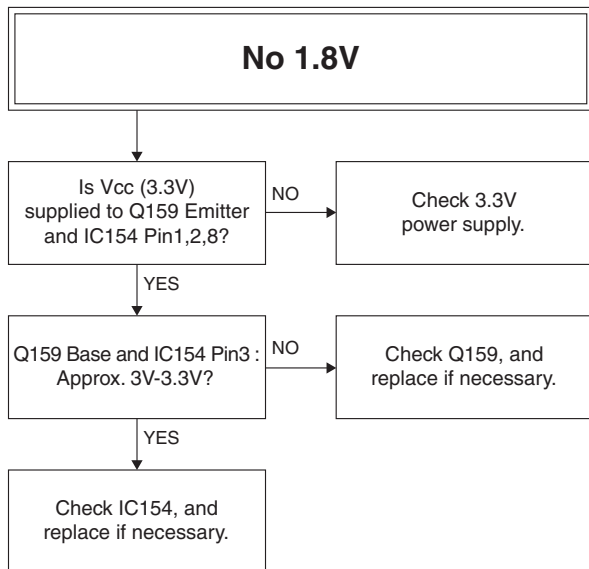
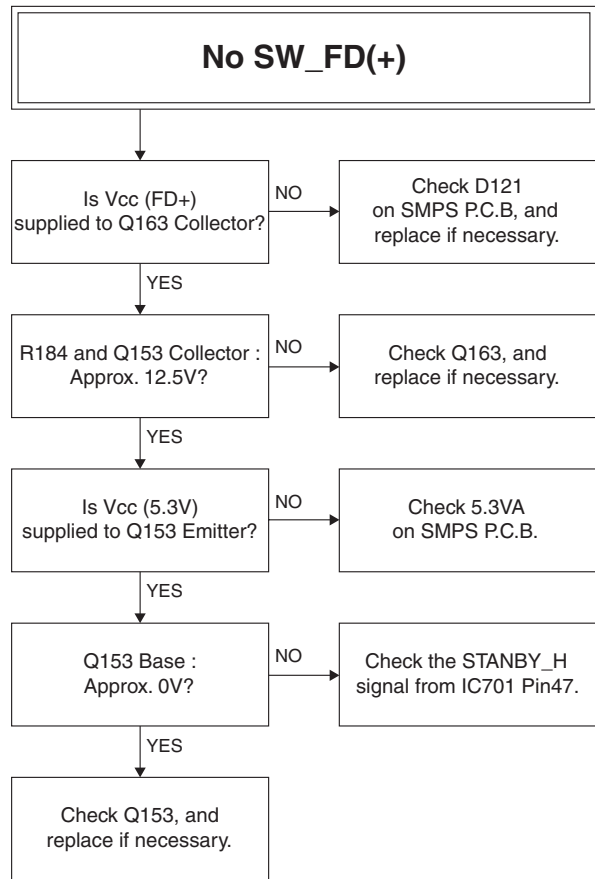
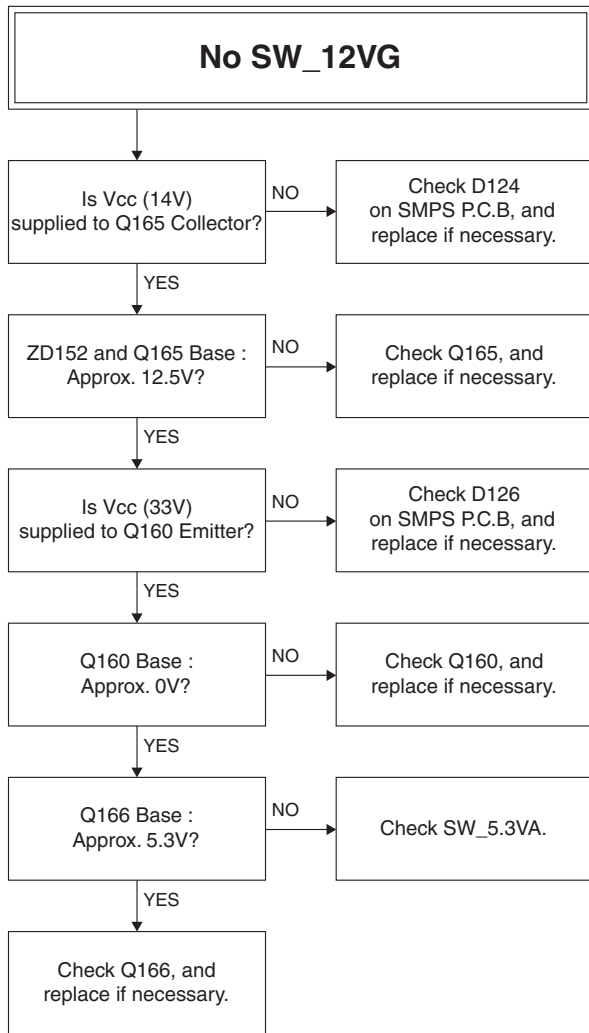

**(3) SYSTEM Circuit**

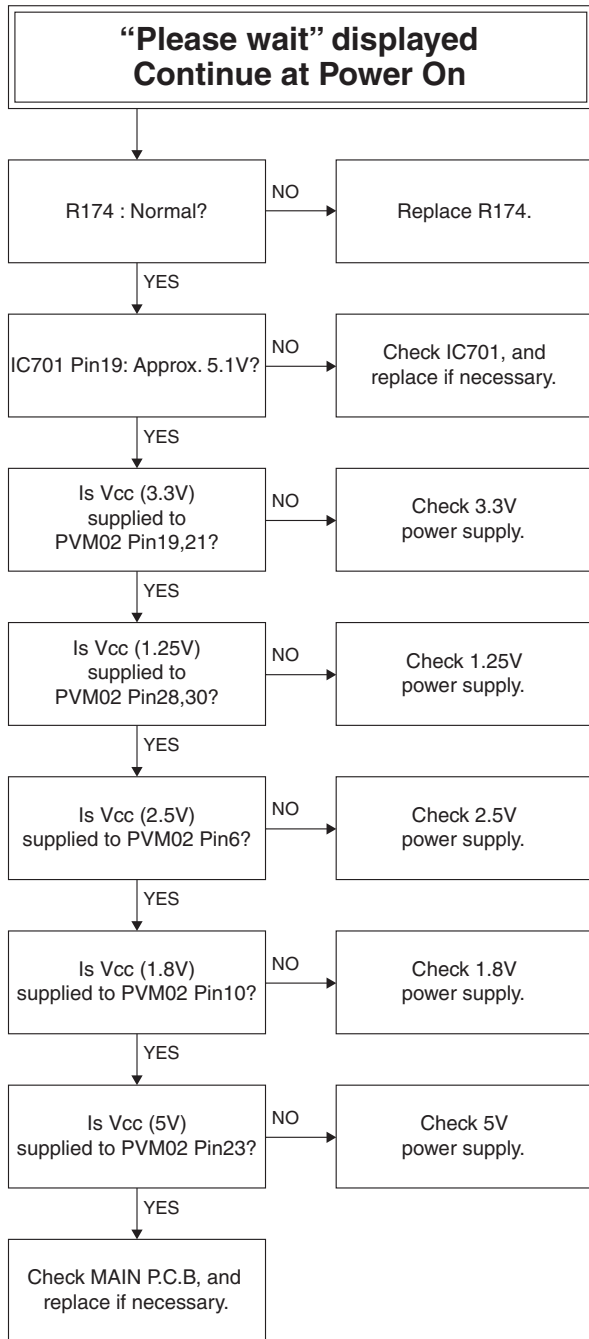

**(4) DVD Drive**

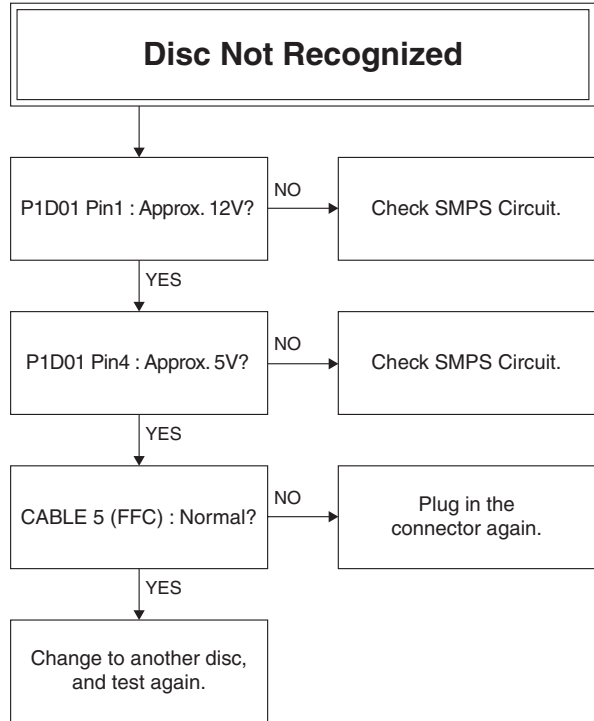



### (5) AUDIO Circuit

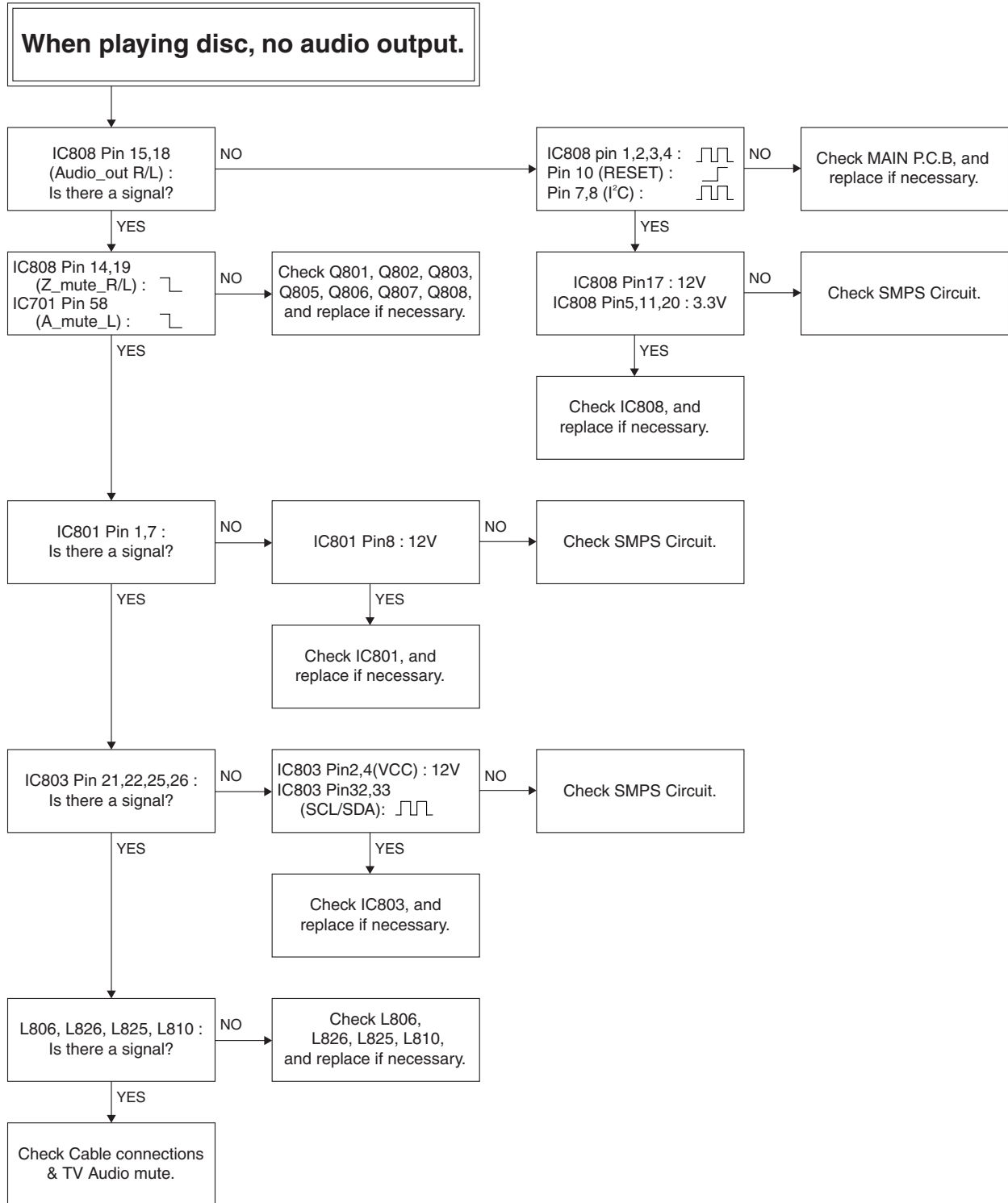

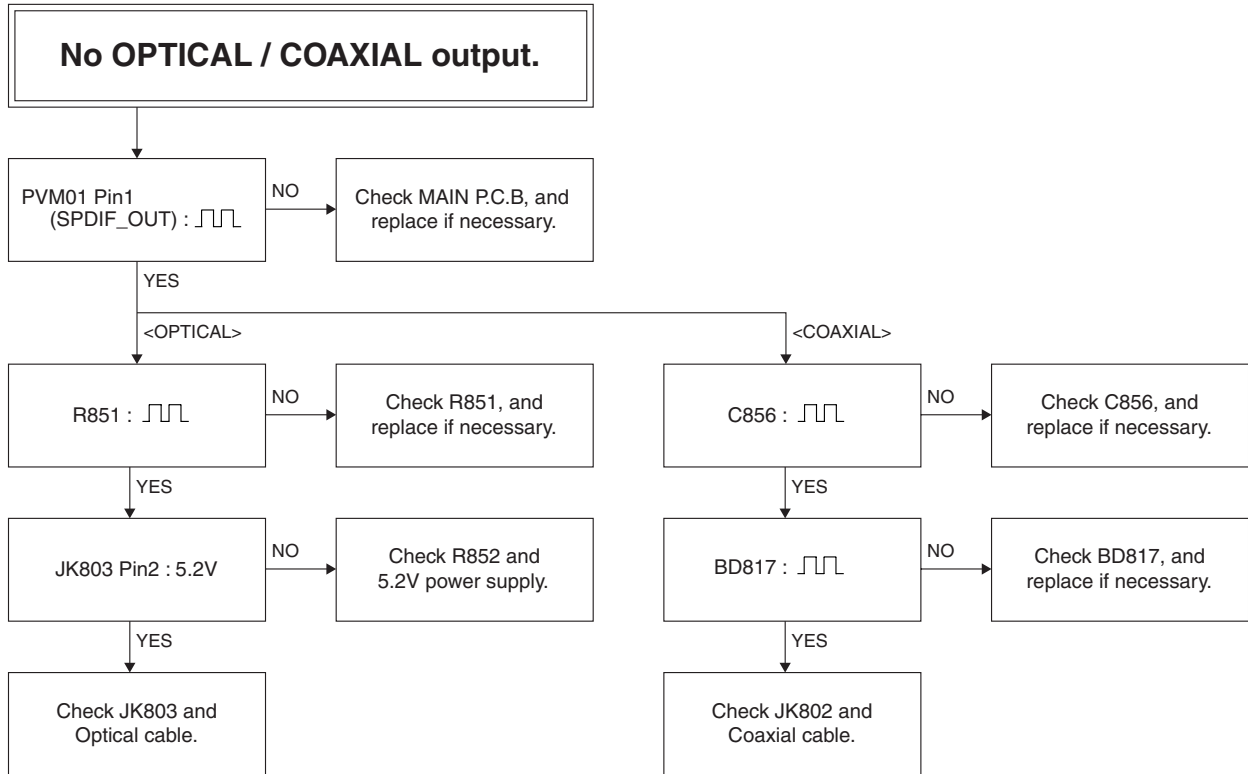

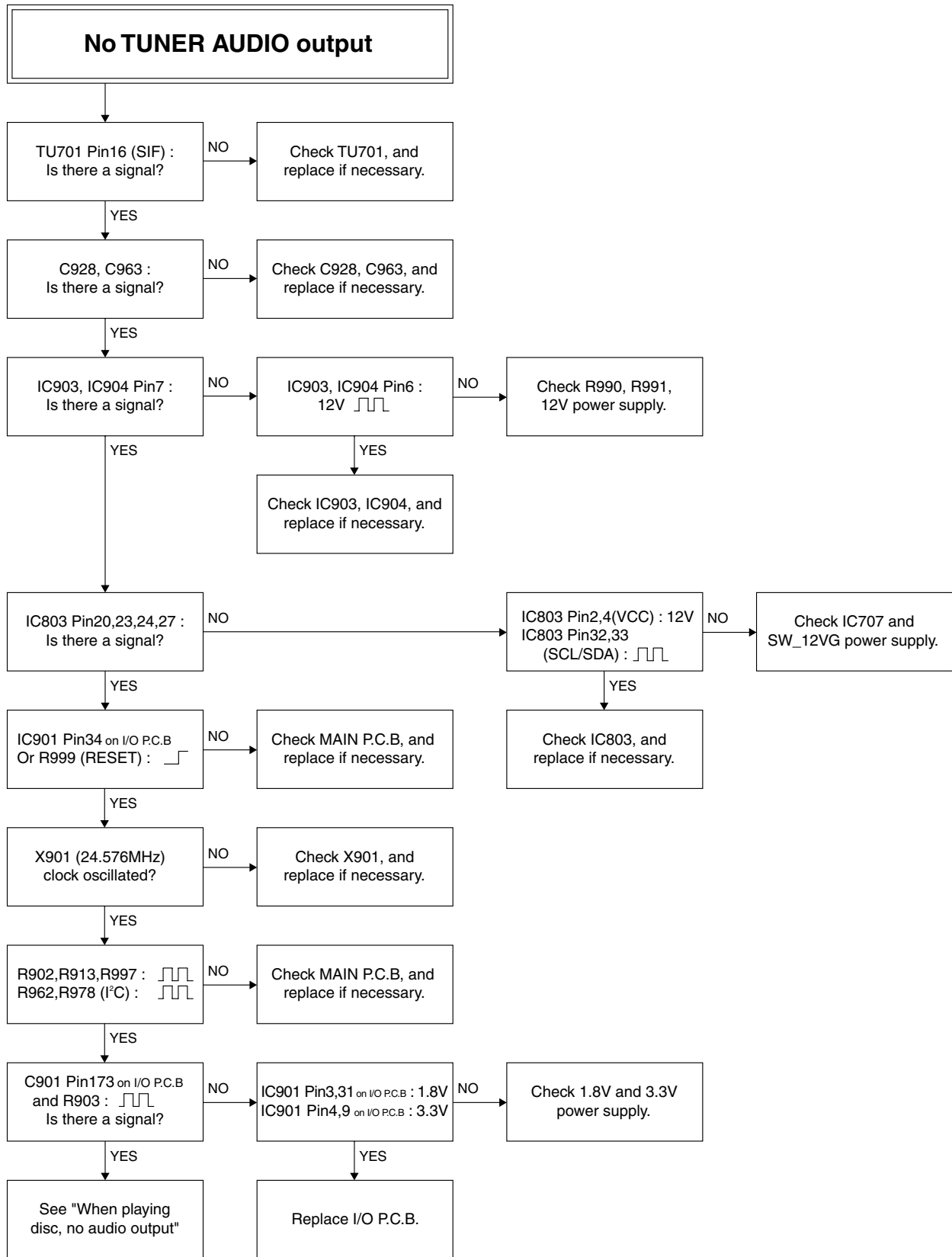

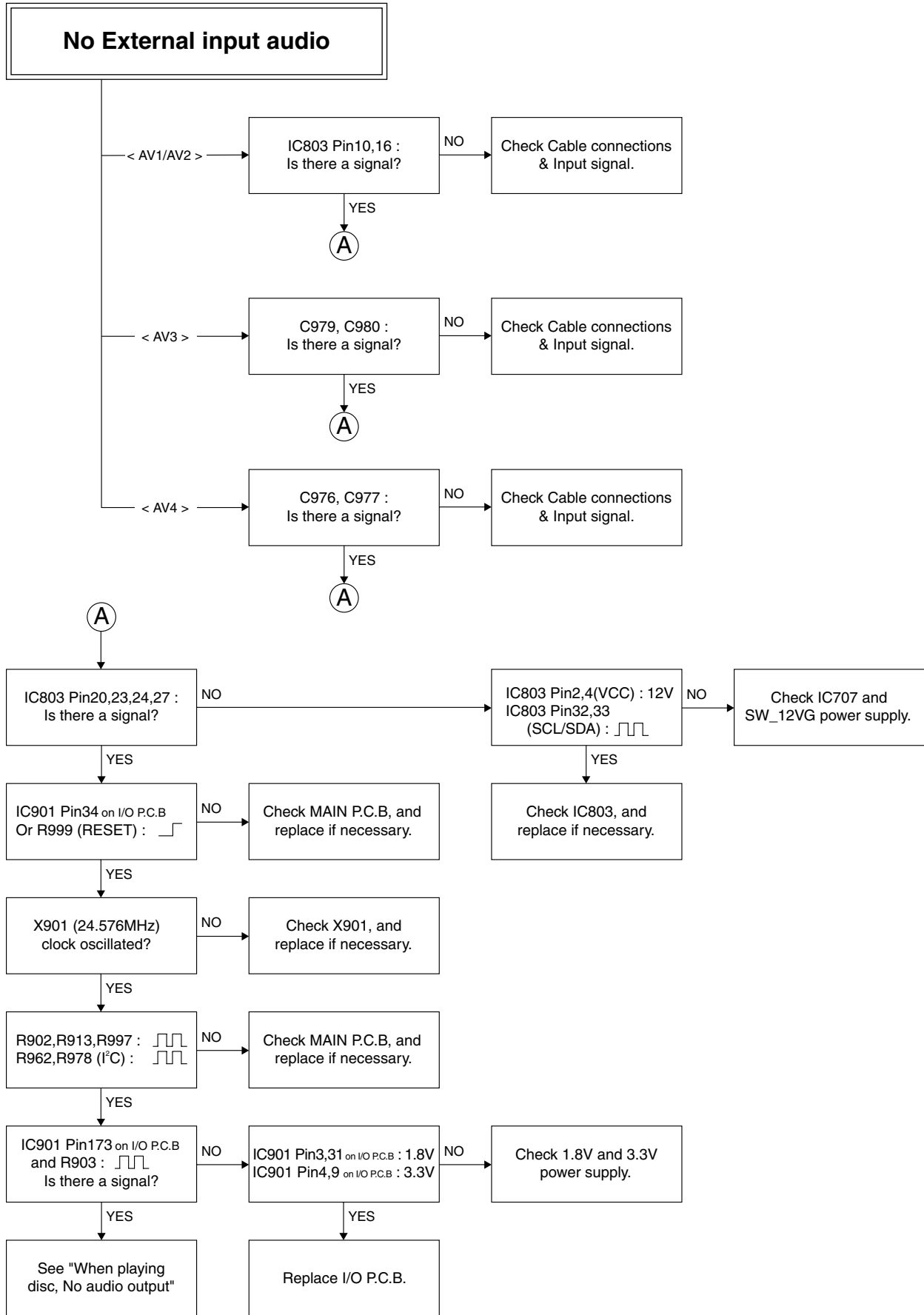

**(6) VIDEO Circuit**

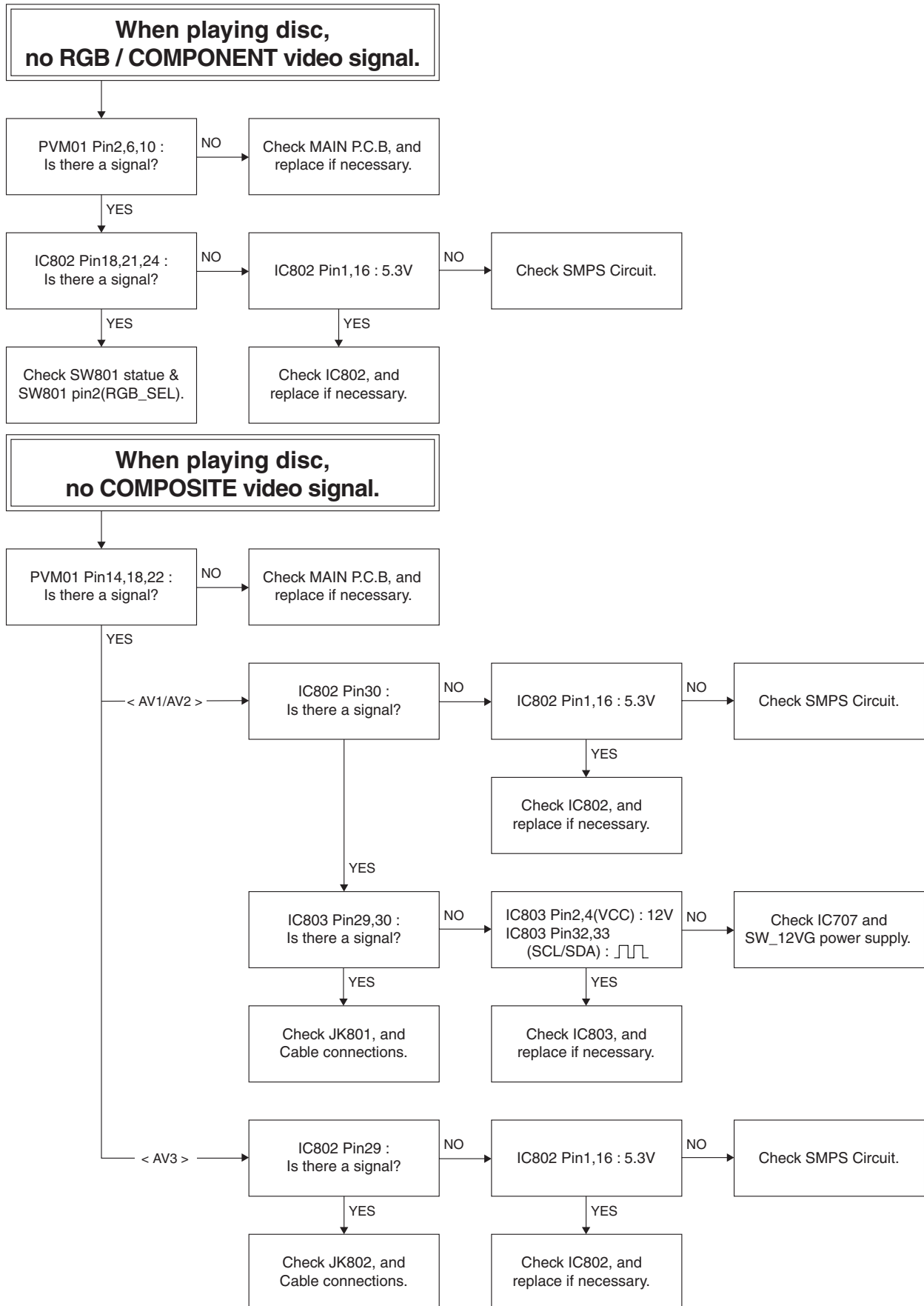

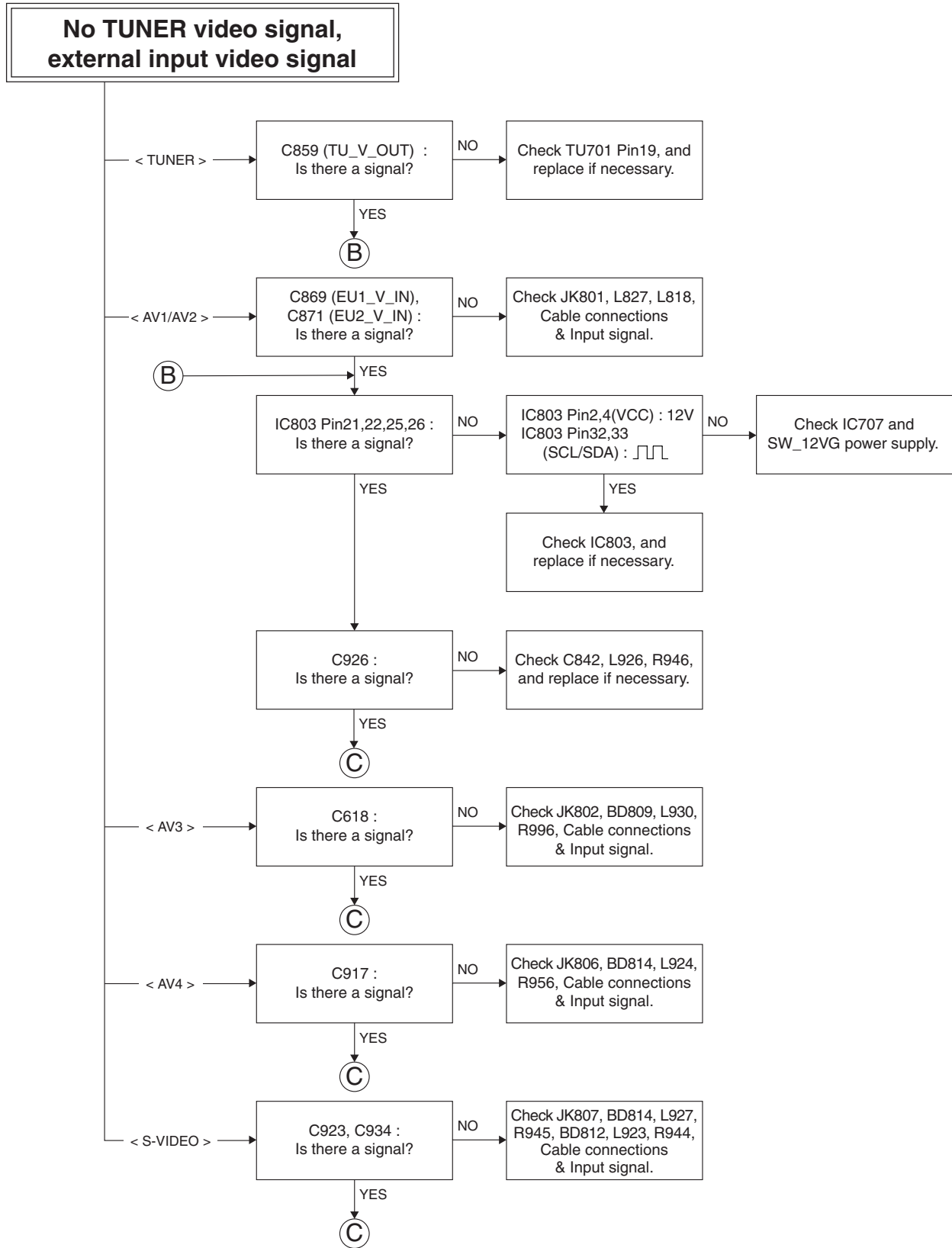

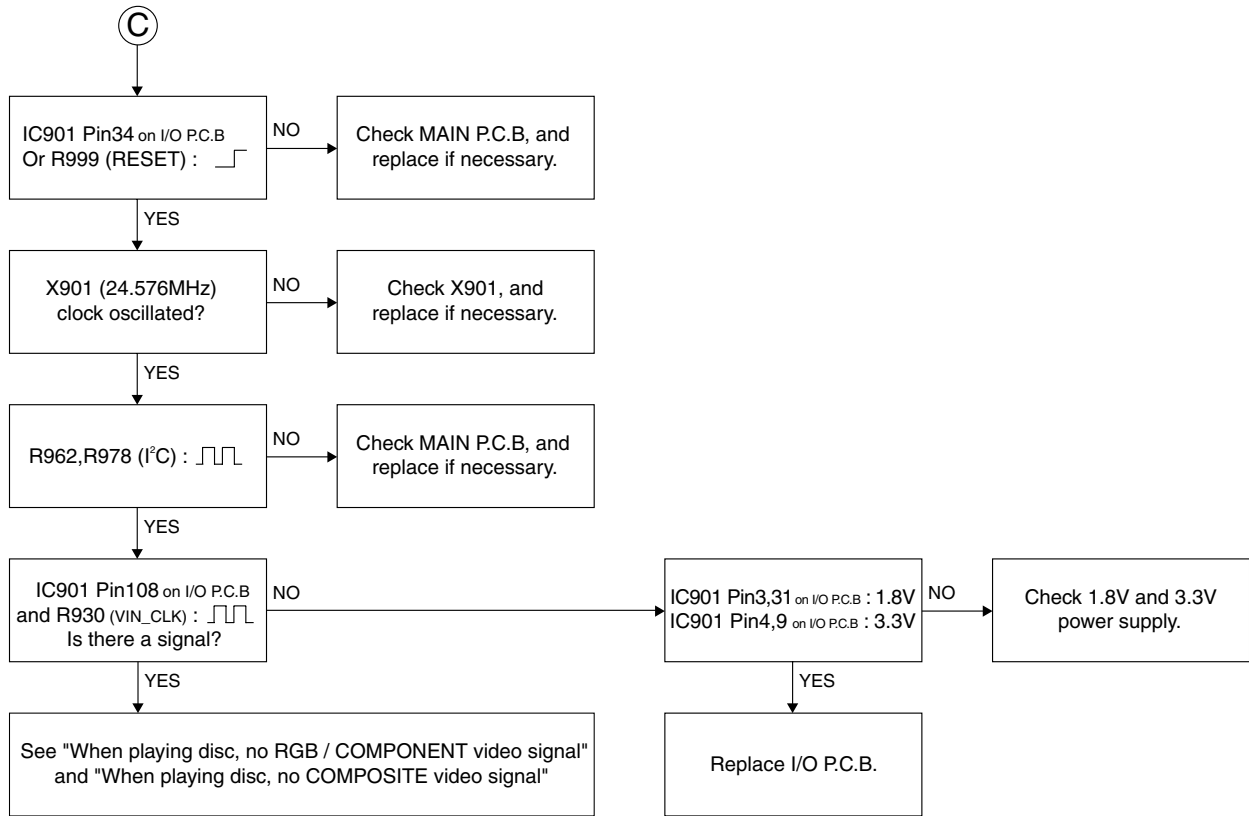

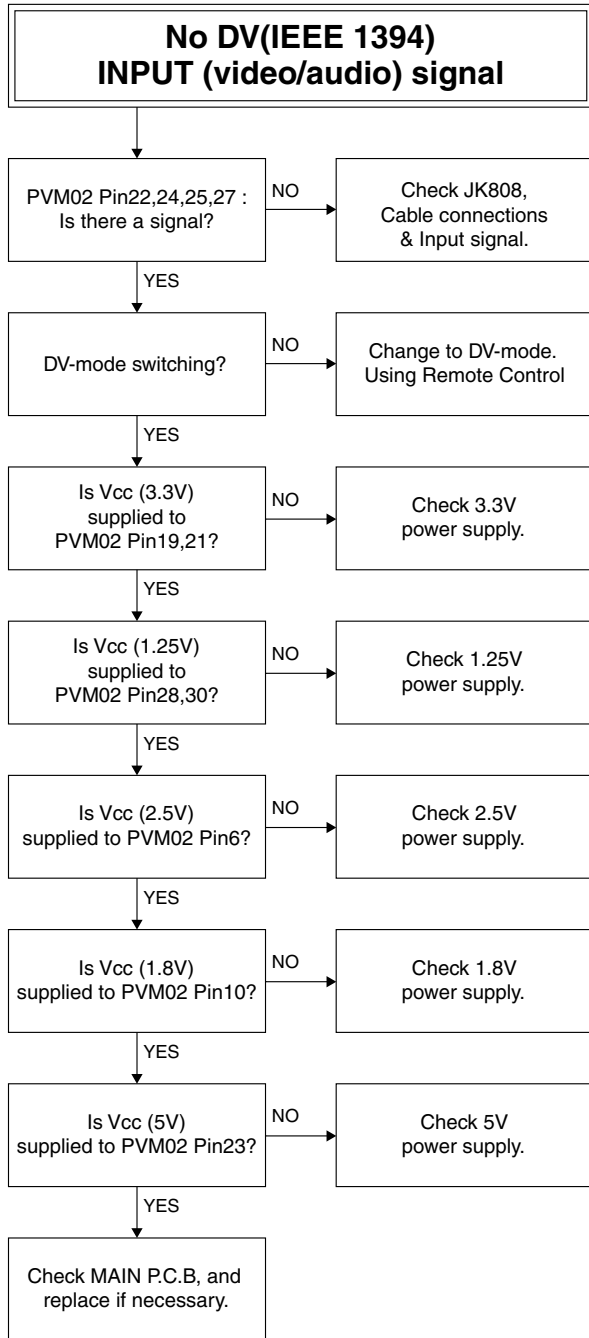



# 4 Disassembly and Reassembly

## 4-1 Order of Disassembly

Refer to the Disassembly Flowchart in Fig. 4-1-1 for the order of removing components. When reassembling components, use the reverse order to removal unless otherwise specified.

### Reading Disassembly Flowchart:

After locating the target component in the flowchart, remove all components of the target in sequence, following the arrows (routes) from the top of flowchart. If multiple routes exist to the target component from the top of flowchart, remove all the components on all the routes.

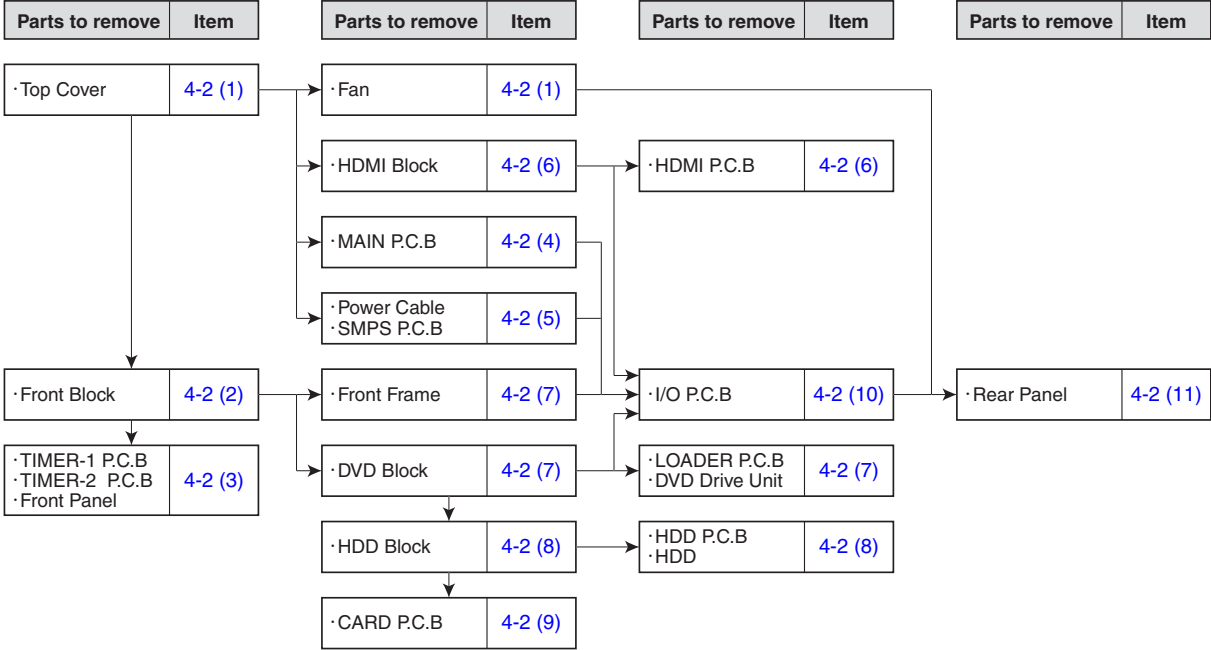

Fig. 4-1-1 Disassembly Flowchart

## 4-2 Disassembly

### Information:

Numbers in figures are step numbers in disassembly procedure, and letters in brackets [ ] show the types of screw.

### (1) Top Cover, Fan

#### ■ Top Cover (a)

- 1) Remove the nine screws [A].
- 2) Remove the top cover in the direction of the arrow.
- 3) While extending both sides of the rear of top cover in the directions of arrows, remove the top cover.

#### ■ Fan (b)

- 4) Disconnect the connector of fan motor from SMPS P.C.B.
- 5) Remove the two screws [J].

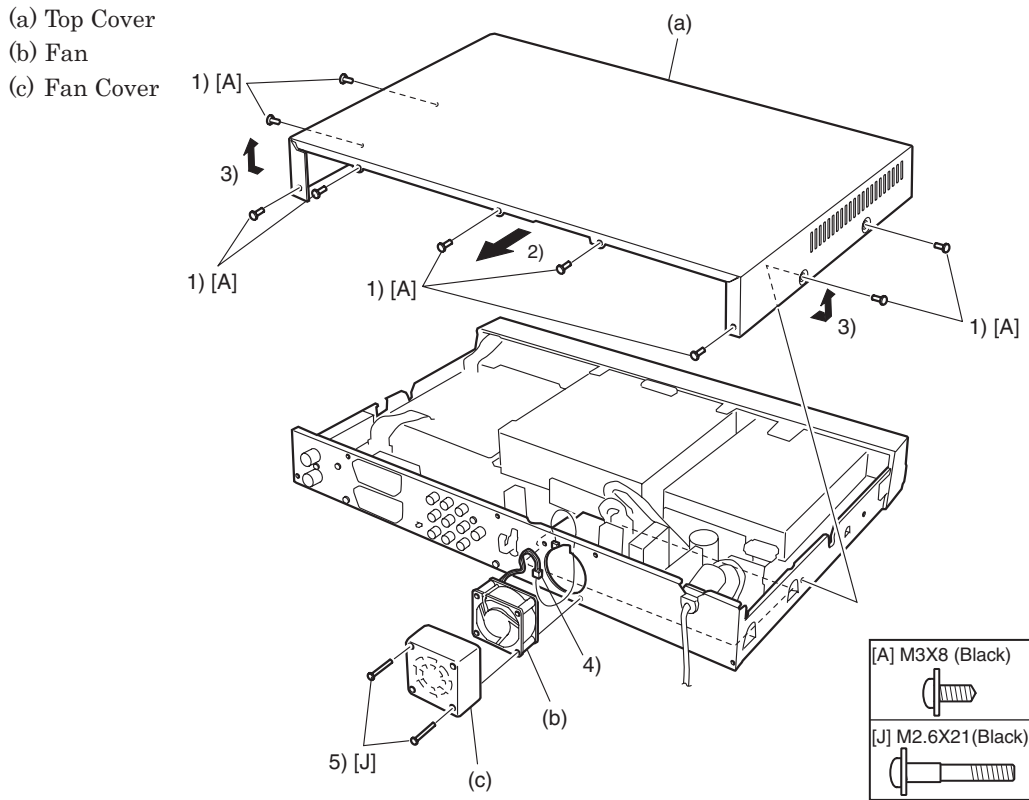

Fig. 4-2-1 Top Cover, Fan

## (2) Front Block

- 1) Disconnect the FFC on MAIN P.C.B (b).
- 2) Release the seven tabs.
- 3) Remove the front block (a) in the direction of the arrow.

- (a) Front Block
- (b) MAIN P.C.B.

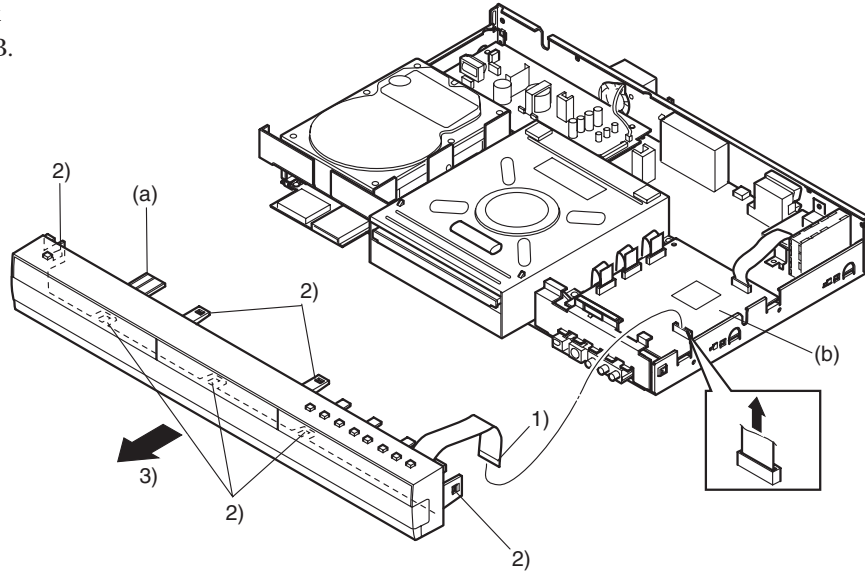

Fig. 4-2-2 Front Block

## (3) TIMER-1 P.C.B, TIMER-2 P.C.B, Front Panel

- 1) Remove the three screws [B].
- 2) Disconnect the two connectors.

### Information

During reassembly, attach the earth plates (d) to the specified positions, making sure the orientation is correct.

- (a) TIMER-1 P.C.B
- (b) TIMER-2 P.C.B
- (c) Front Panel
- (d) Earth Plate

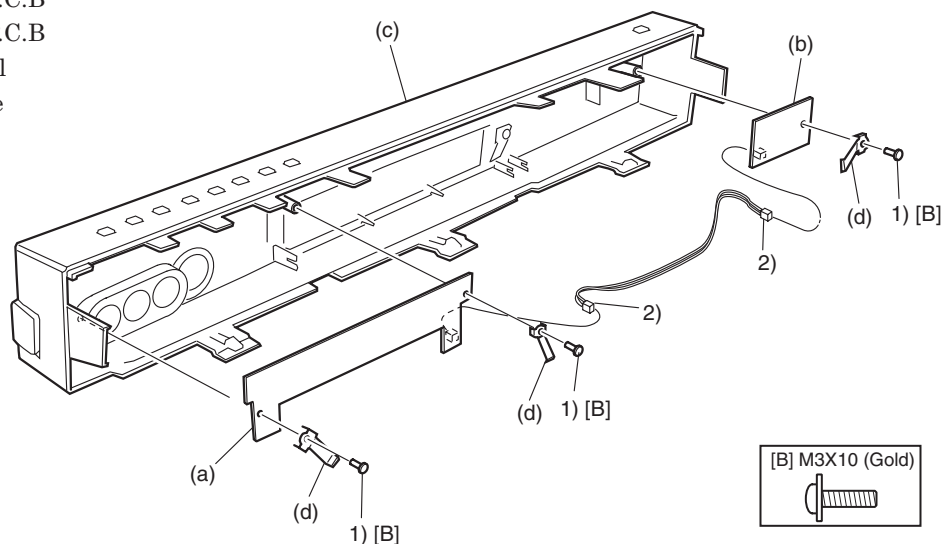

Fig. 4-2-3 TIMER-1 P.C.B, TIMER-2 P.C.B, Front Panel

#### (4) MAIN P.C.B

- 1) Disconnect the four FFC.
- 2) Remove the two screws [C] and the two screws [D].
- 3) Remove the MAIN P.C.B (a) from the I/O P.C.B (b) in the direction of the arrow.

The MAIN and I/O P.C.B are directly joined via the connector: Removing the MAIN P.C.B in a direction other than that of the arrow could damage the connector.

#### Caution during disassembly and reassembly:

Securely connect the MAIN and I/O P.C.B.

- (a) MAIN P.C.B
- (b) I/O P.C.B
- (c) HDMI Block
- (d) SMPS P.C.B

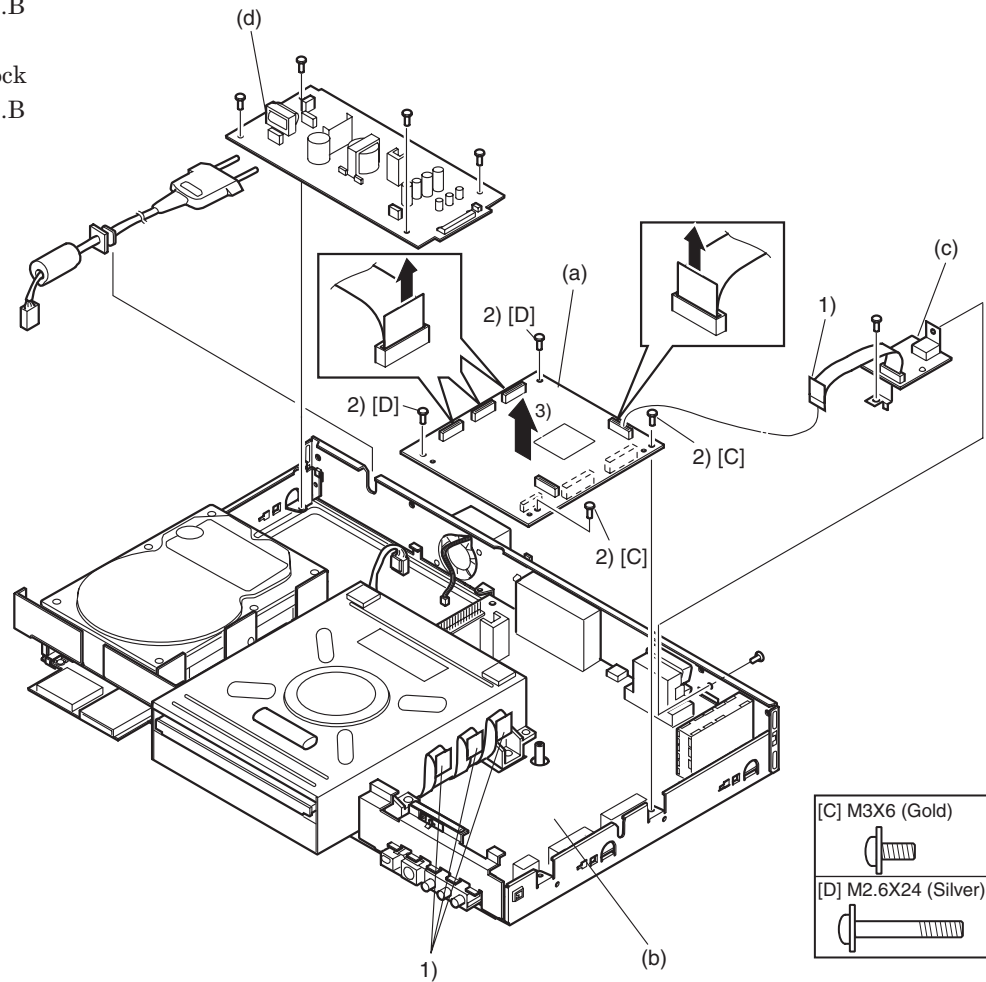

Fig. 4-2-4 MAIN P.C.B

## (5) Power Cable, SMPS P.C.B

### ■ Power Cable (a)

- 1) Disconnect the connector of the power cable.
- 2) Remove the power cable from the rear panel (e).

### ■ SMPS P.C.B (b)

- 3) Disconnect the two connectors.
- 4) Remove the four screws [C].
- 5) Remove the SMPS P.C.B from the I/O P.C.B (c) in the direction of the arrow.

The SMPS and I/O P.C.B are directly joined via the connector: Removing the SMPS P.C.B in a direction other than that of the arrow could damage the connector.

### Caution during disassembly and reassembly:

Securely connect the SMPS and I/O P.C.B.

- (a) Power Cable
- (b) SMPS P.C.B
- (c) I/O P.C.B
- (d) HDMI Block
- (e) Rear Panel
- (f) MAIN P.C.B

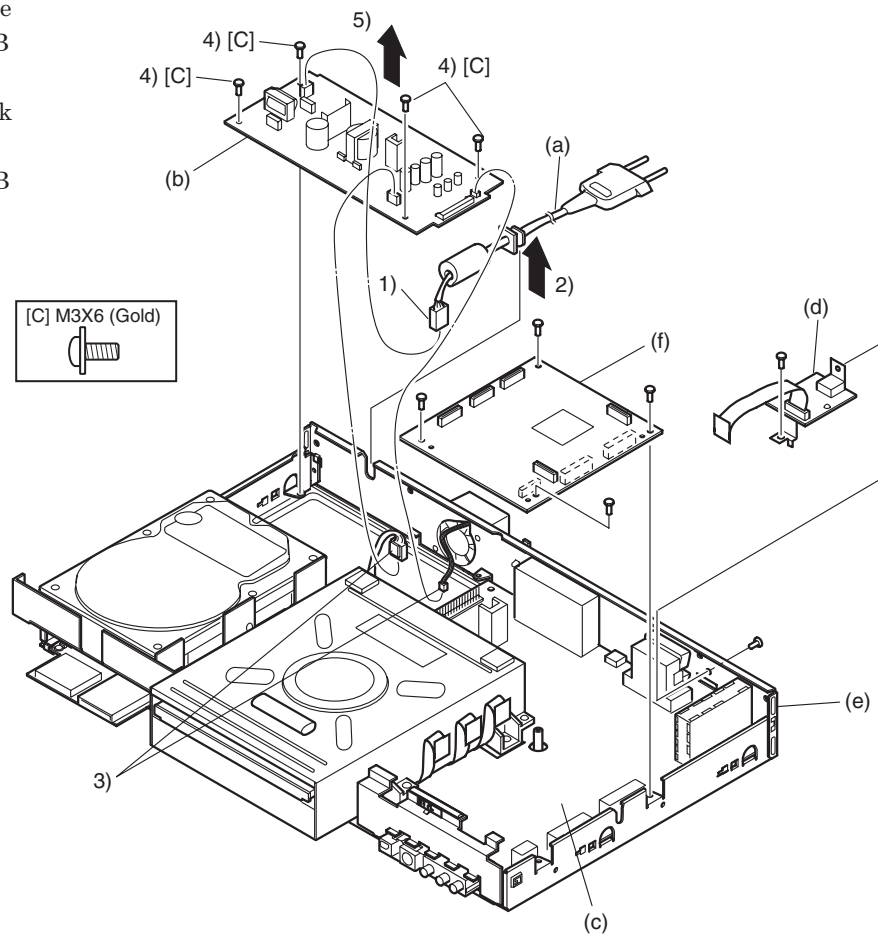

Fig. 4-2-5 Power Cable, SMPS P.C.B

## (6) HDMI Block, HDMI P.C.B

- 1) Disconnect the FFC.
- 2) Remove the screw [G].
- 3) Remove the screw [C], and then lift the unit of the HDMI block (a).
- 4) Remove the two screws [H] and remove the HDMI P.C.B (b).

### Caution during disassembly and reassembly:

Securely connect the HDMI P.C.B and the HDMI frame (c).

- (a) HDMI Block
- (b) HDMI P.C.B
- (c) HDMI Frame
- (d) MAIN P.C.B
- (e) SMPS P.C.B

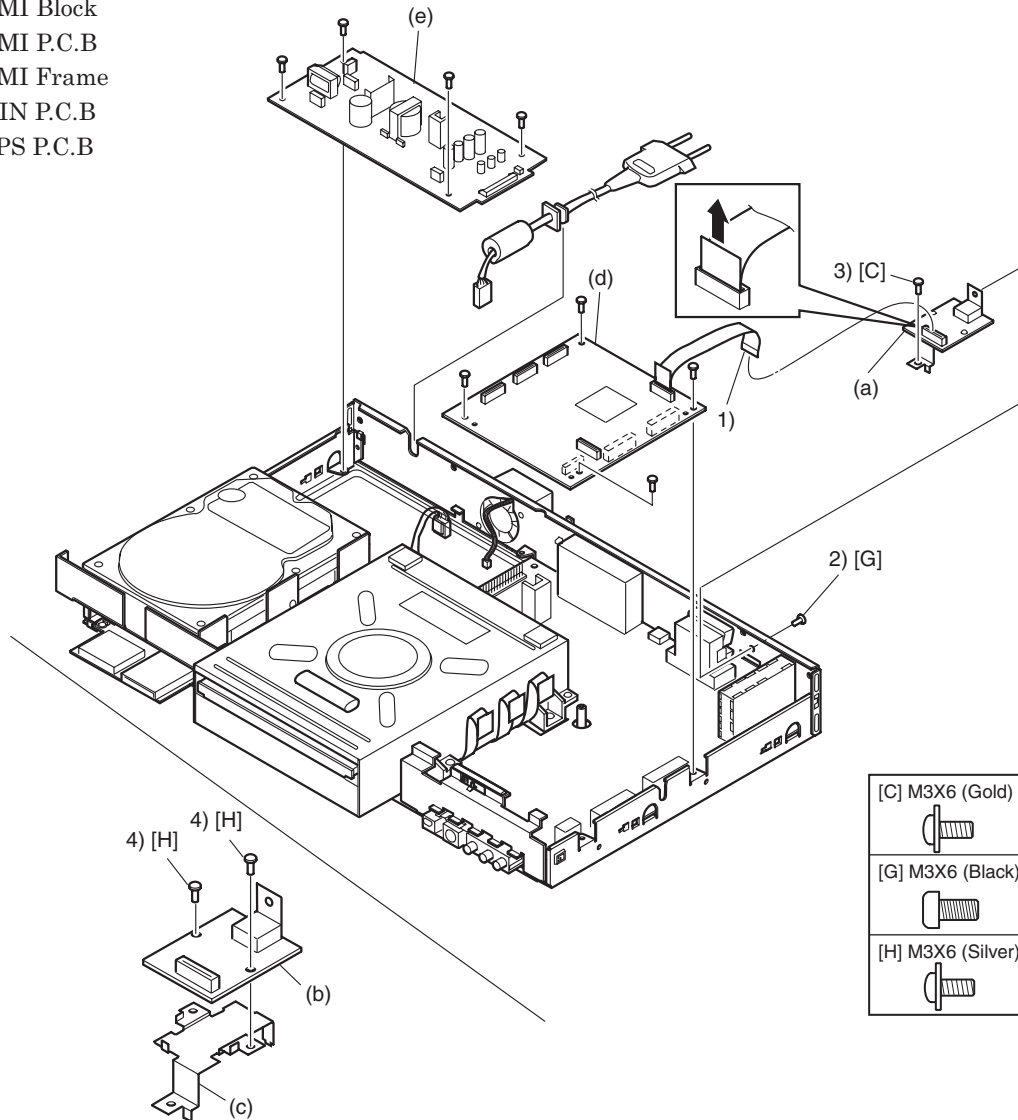

Fig. 4-2-6 HDMI Block, HDMI P.C.B

## (7) Front Frame, DVD Block, DVD Drive Unit, LOADER P.C.B

### ■ Front Frame (a)

- 1) Remove the two screws [C]
- 2) Remove the front frame in the direction of the arrow.

### ■ DVD Block (b)

- 3) Disconnect the FFC.
- 4) Disconnect the connector.
- 5) Remove the four screws [E].
- 6) Remove the DVD block in the direction of the arrow.

### ■ DVD Drive Unit (c), LOADER P.C.B (d)

- 7) Disconnect the FFC from the LOADER P.C.B.
- 8) Remove the LOADER P.C.B from the DVD drive unit in the direction of the arrow.

### Caution during disassembly and reassembly:

Securely connect the LOADER P.C.B and the DVD drive unit.

- (a) Front Frame
- (b) DVD Block
- (c) DVD Drive Unit
- (d) LOADER P.C.B
- (e) MAIN P.C.B

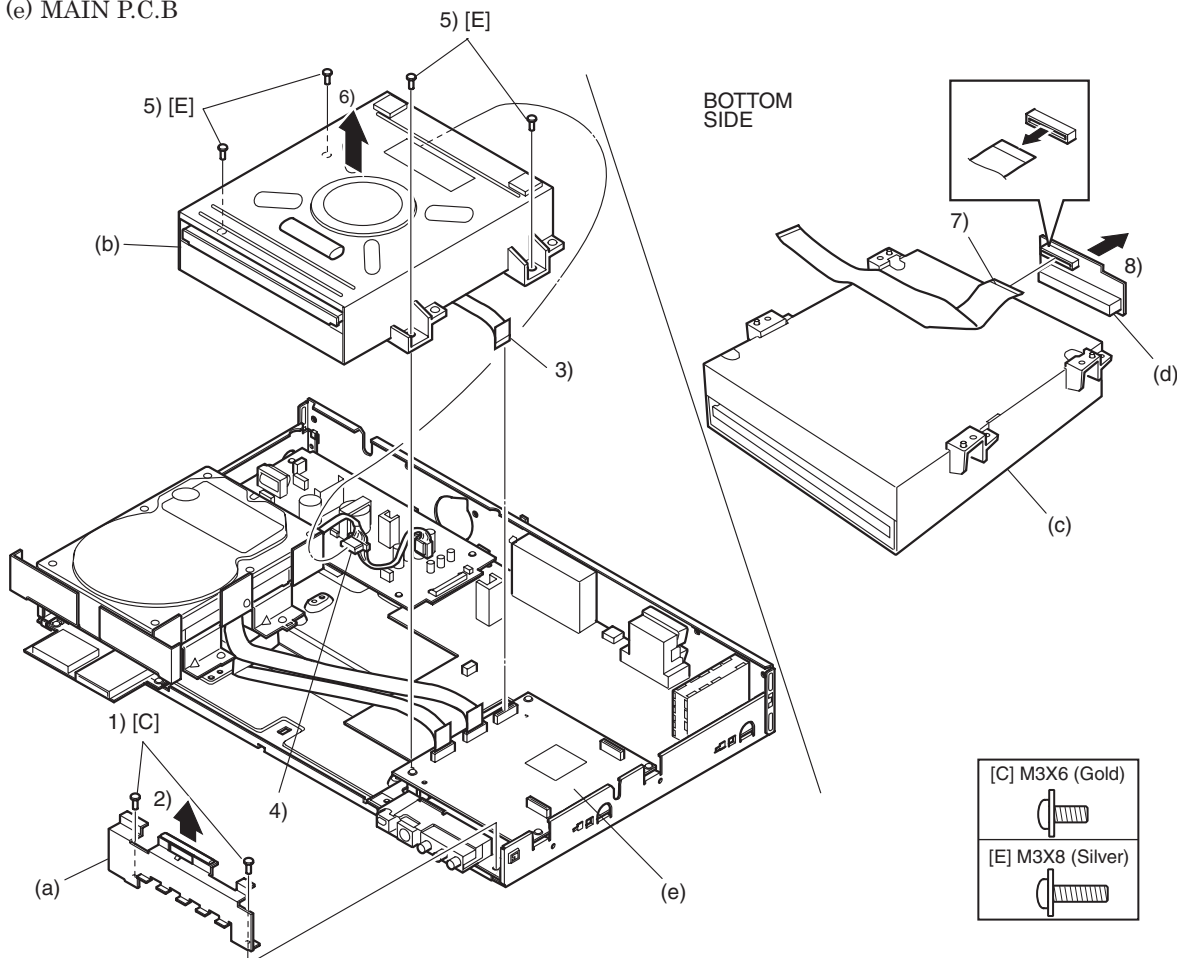

Fig. 4-2-7 Front Frame, DVD Block, DVD Drive Unit, LOADER P.C.B

## (8) HDD Block, HDD P.C.B, HDD

### ■ HDD Block (a)

- 1) Disconnect the FFC.
- 2) Disconnect the connector.
- 3) Remove the four screws [C].
- 4) Remove the HDD block in the direction of the arrow.

### ■ HDD P.C.B (b), HDD (c)

- 5) Disconnect the FFC from the HDD P.C.B..
- 6) Remove the screw [C].
- 7) Remove the HDD P.C.B from the HDD in the direction of the arrow.

### Caution during disassembly and reassembly:

Securely connect the HDD P.C.B and the HDD.

- 8) Remove the six screws [F] and the HDD from HDD frame (d).

- (a) HDD Block
- (b) HDD P.C.B
- (c) HDD
- (d) HDD Frame
- (e) HDD Plate

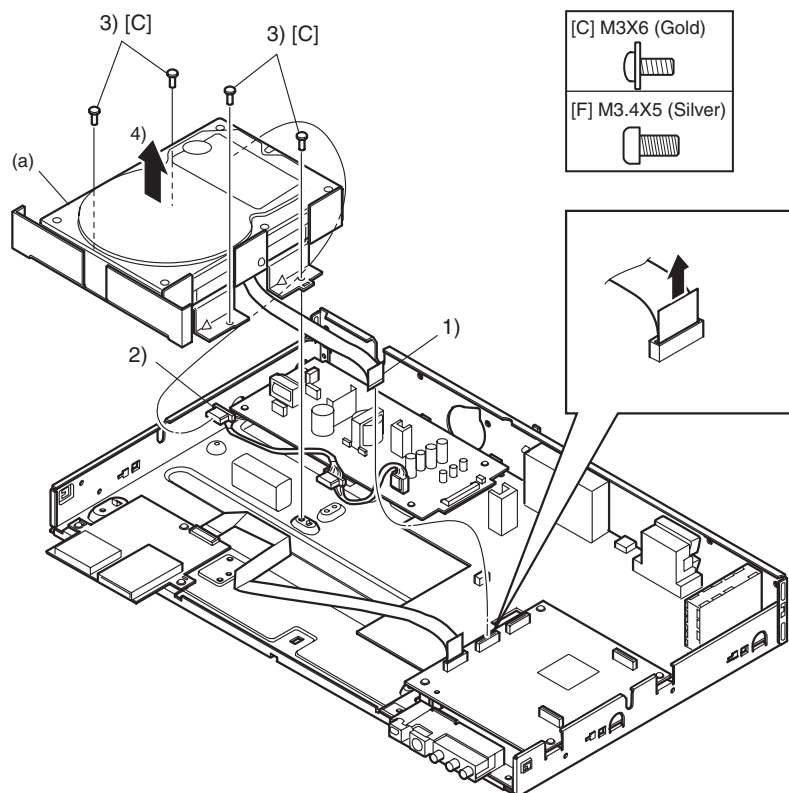

Fig. 4-2-8A HDD Block



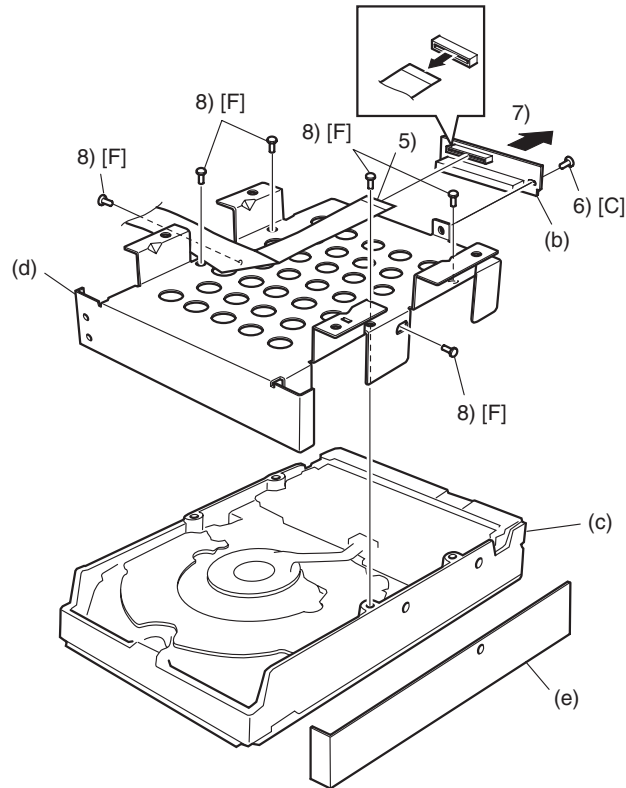

Fig. 4-2-8B HDD P.C.B, HDD

### (9) CARD P.C.B

- 1) Disconnect the FFC.
- 2) Remove the three screws [C]
- 3) Remove the CARD P.C.B (a) in the direction of the arrow.

(a) CARD P.C.B

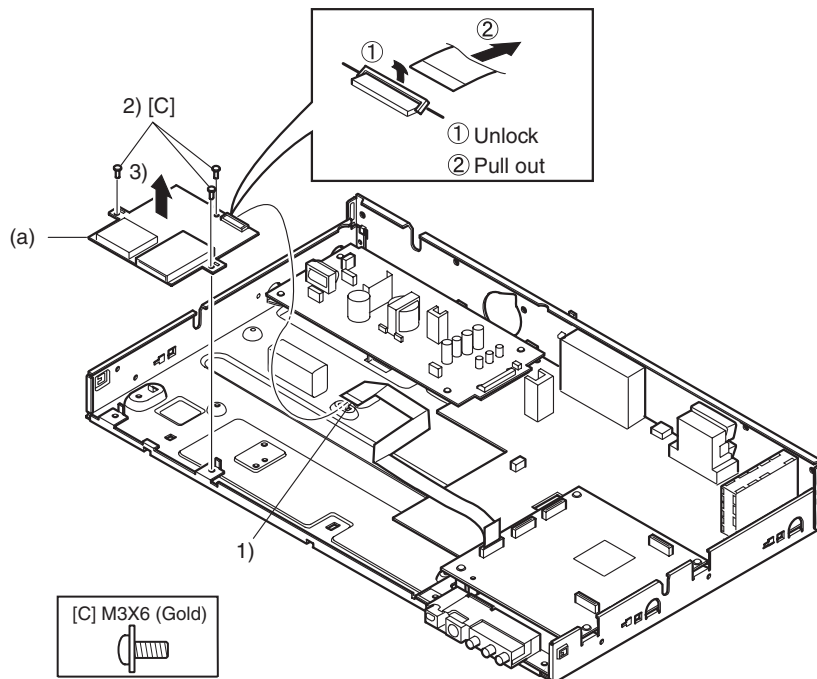

Fig. 4-2-9 CARD P.C.B

### (10) I/O P.C.B

- 1) Remove the five screws [K].
- 2) Remove the three screws [C].
- 3) Remove the I/O P.C.B in the direction of the arrow.

(a) I/O P.C.B

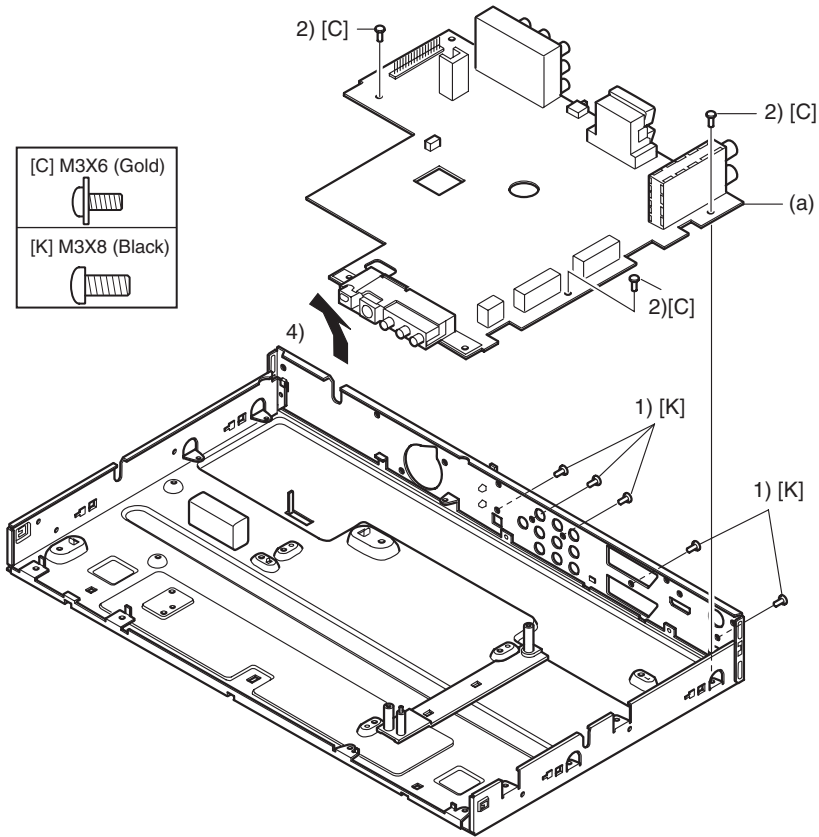

Fig. 4-2-10 I/O P.C.B

### (11) Rear Panel

- 1) Remove the two screws [K].
- 2) Move the bottom section of rear panel in the direction of the arrow.
- 3) Remove the rear panel in the direction of the arrow.

(a) Rear Panel

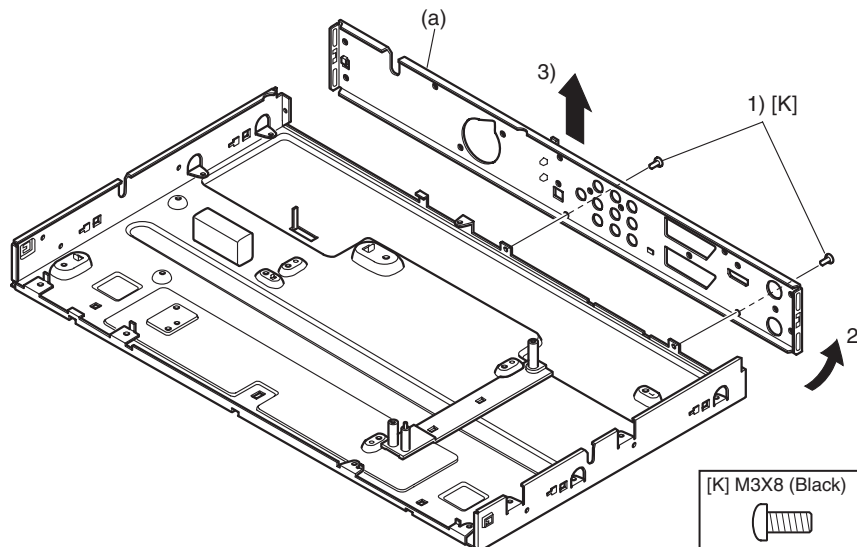
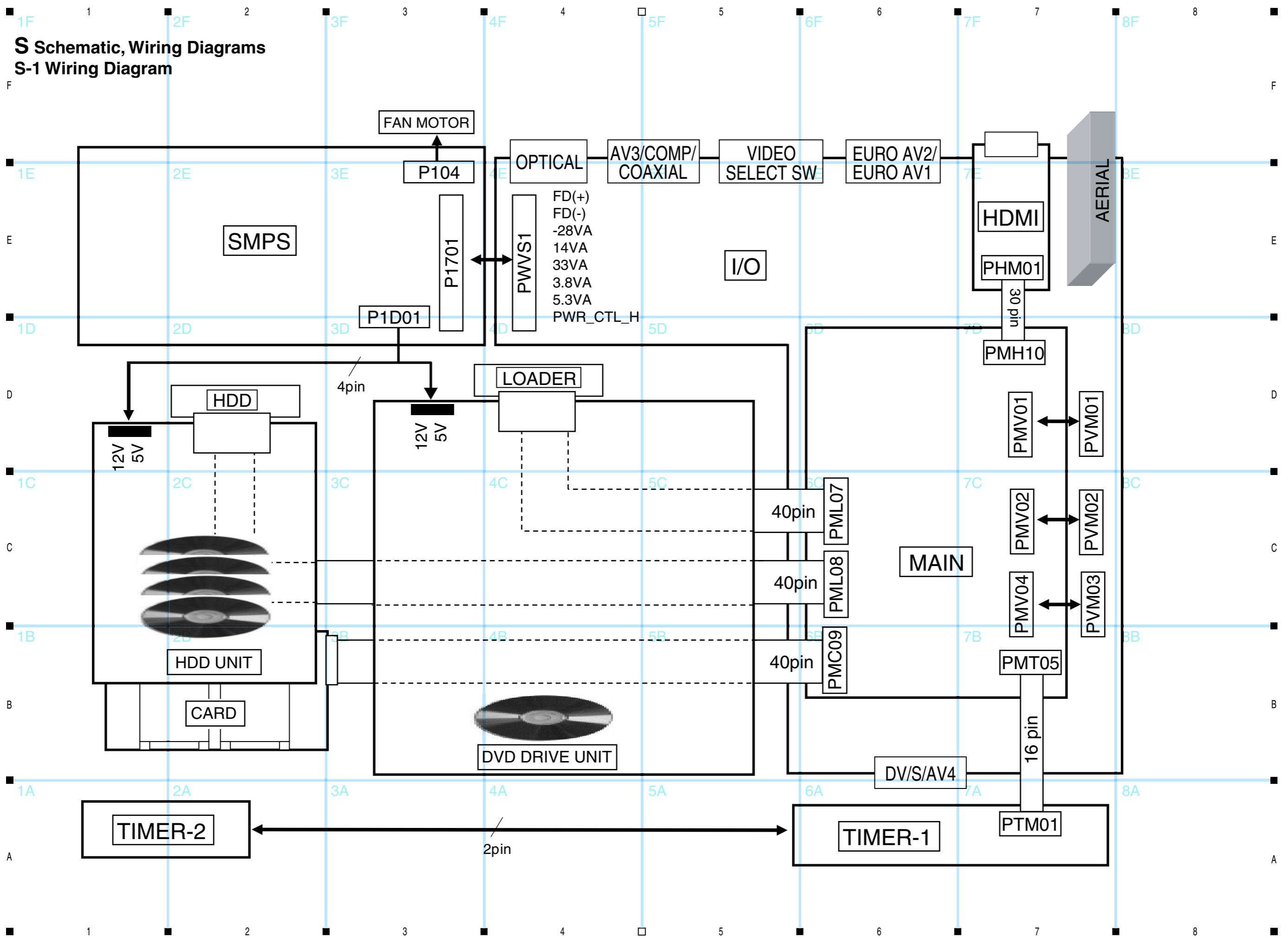

Fig. 4-2-11 Rear Panel



**THE UPDATED PARTS LIST  
FOR THIS MODEL IS  
AVAILABLE ON ESTA**

**S Schematic, Wiring Diagrams**  
**S-1 Wiring Diagram**



# S-2 SMPS Schematic Diagram

The following shows the name of circuit and plug to which signal is connected and the address:

Name of circuit diagram	To MAIN	VIDEO
Address	(3A)	
Name of circuit diagram and plug	To MAIN	PG1001
Address	(3A)	AUDIO-L 1 AUDIO-R 2

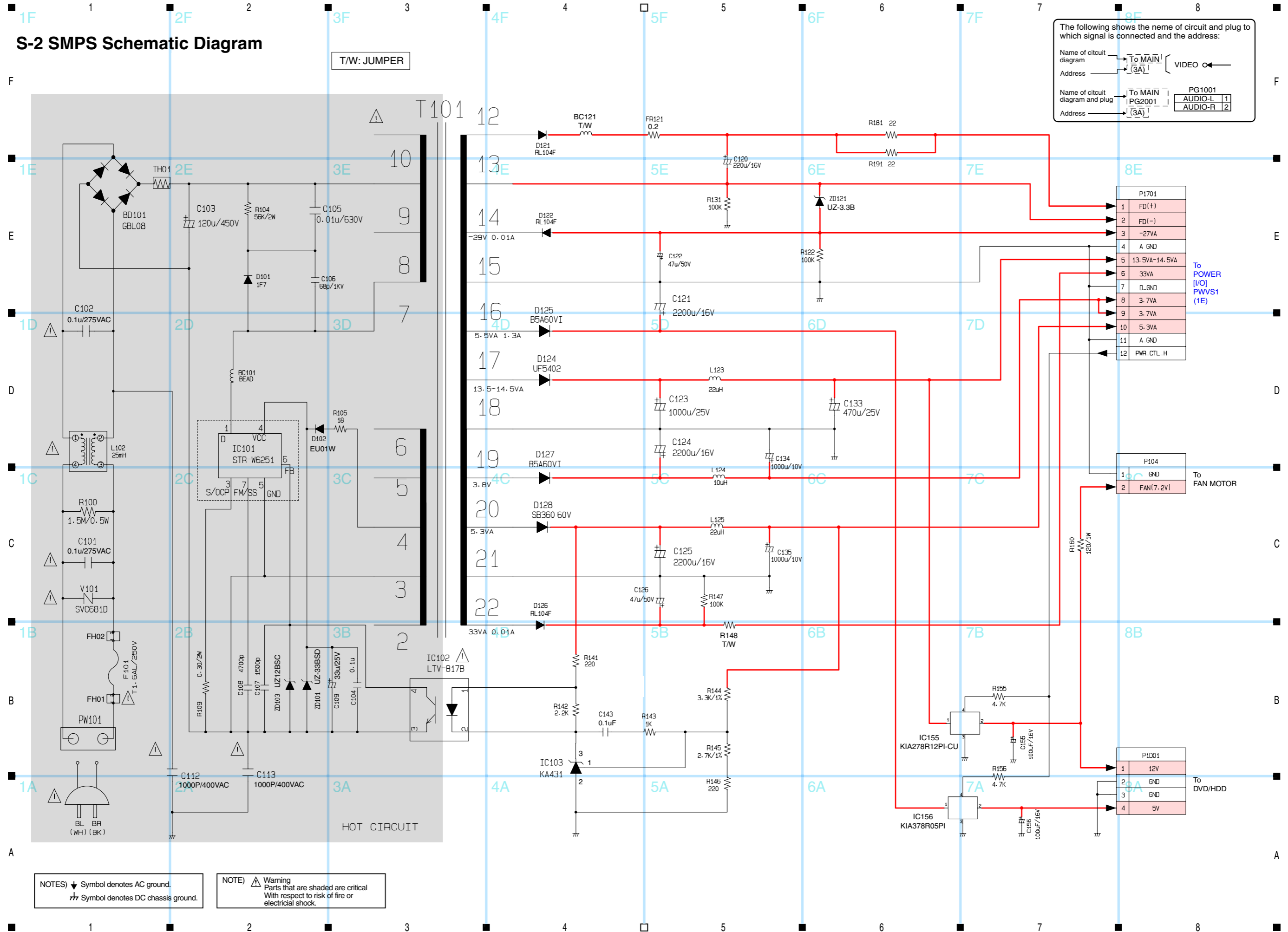

P1701	
1	FD(+)
2	FD(-)
3	-27VA
4	A_GND
5	13.5VA-14.5VA
6	33VA
7	D_GND
8	3.7VA
9	3.7VA
10	5.3VA
11	A_GND
12	PWR_CTL_H

To POWER [I/O] PWVS1 (1E)

P104	
1	GND
2	FAN(7.2V)

To FAN MOTOR

P1001	
1	12V
2	GND
3	GND
4	5V

To DVD/HDD

NOTES) ⚡ Symbol denotes AC ground.  
 ⚡ Symbol denotes DC chassis ground.

NOTE) ⚠ Warning Parts that are shaded are critical With respect to risk of fire or electrical shock.

# S-3 POWER Schematic Diagram (I/O P.C.B)

The following shows the name of circuit and plug to which signal is connected and the address:

Name of circuit diagram	To MAIN	VIDEO
Address	(3A)	
Name of circuit diagram and plug	To MAIN	PG1001
Address	(3A)	AUDIO-L 1
		AUDIO-R 2

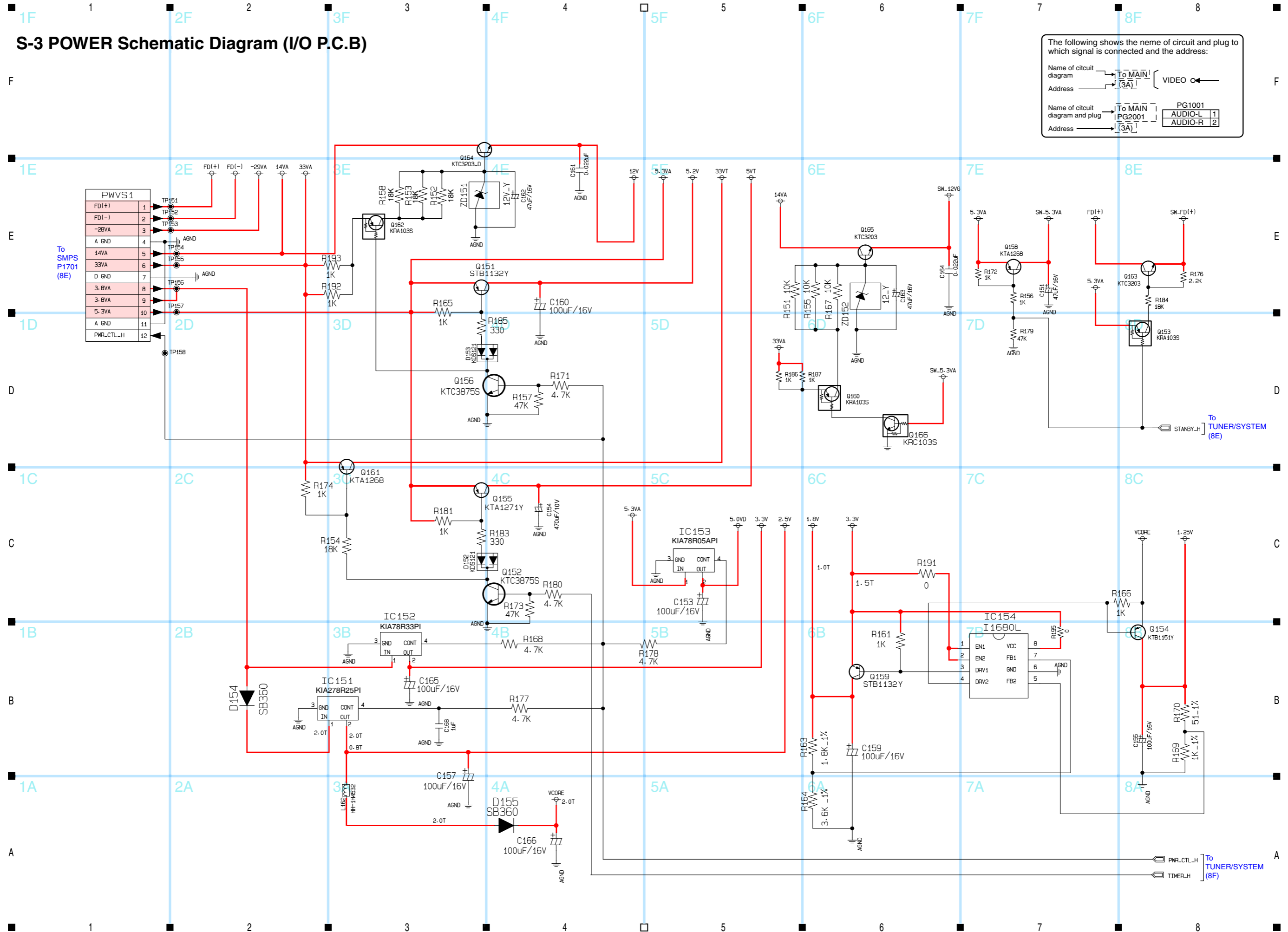

PWS1	
FD(+)	1
FD(-)	2
-28VA	3
A GND	4
14VA	5
33VA	6
D GND	7
3.8VA	8
3.8VA	9
5.3VA	10
A GND	11
PWR_CTL_H	12

To TUNER/SYSTEM (8E)

To TUNER/SYSTEM (8F)

# S-4 TUNER/SYSTEM Schematic Diagram (I/O P.C.B)

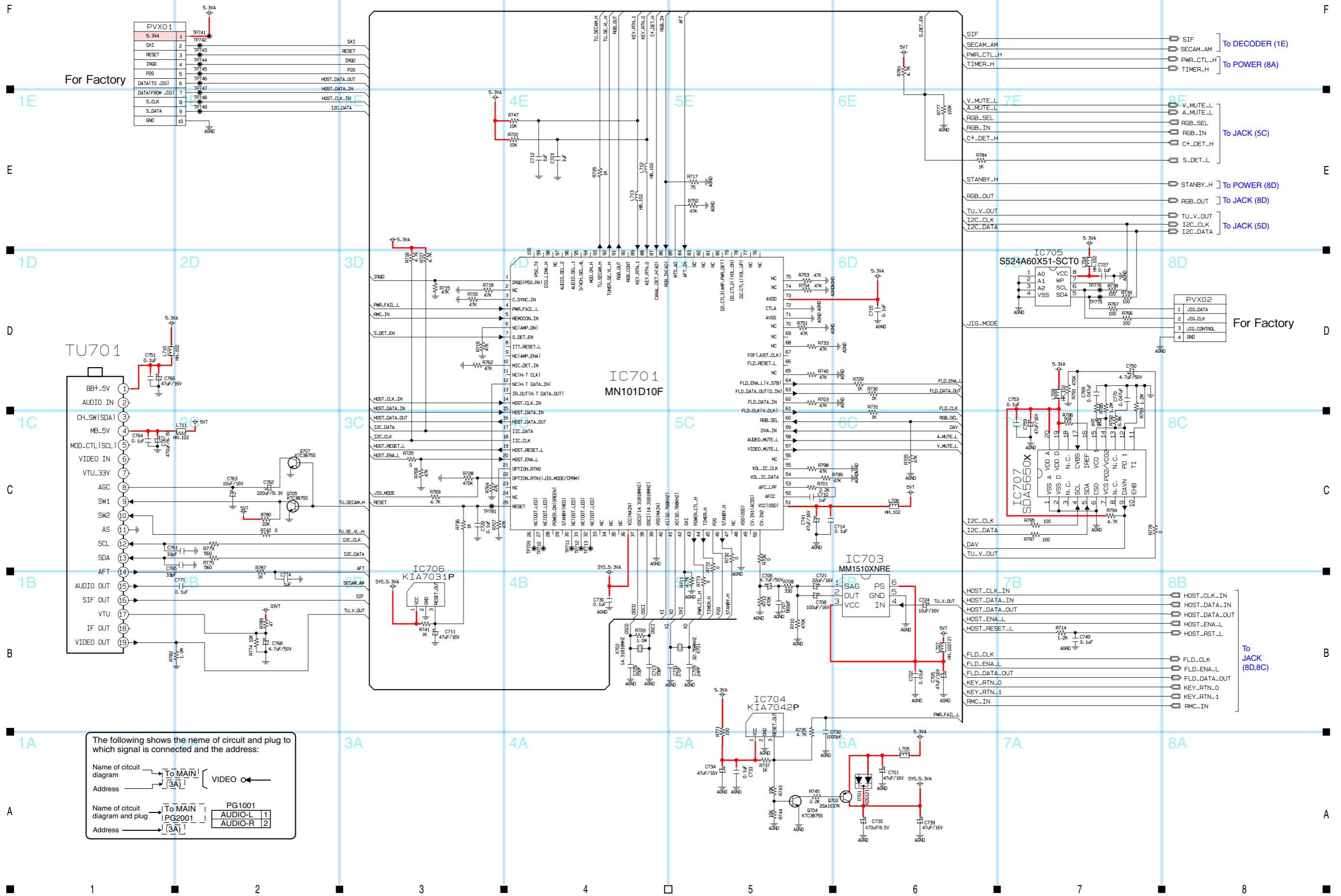

The following shows the name of circuit and plug to which signal is connected and the address:

Name of circuit diagram → To MAIN | VIDEO → (3A)

Name of circuit diagram and plug → To MAIN | PG1001 | AUDIO-L 1 | AUDIO-R 2 | (3A)



# S-5 JACK Schematic Diagram (I/O P.C.B)

The following shows the name of circuit and plug to which signal is connected and the address:

Name of circuit diagram	To MAIN	VIDEO
Address	(3A)	
Name of circuit diagram and plug	To MAIN	PG1001
Address	(3A)	AUDIO-L 1
		AUDIO-R 2

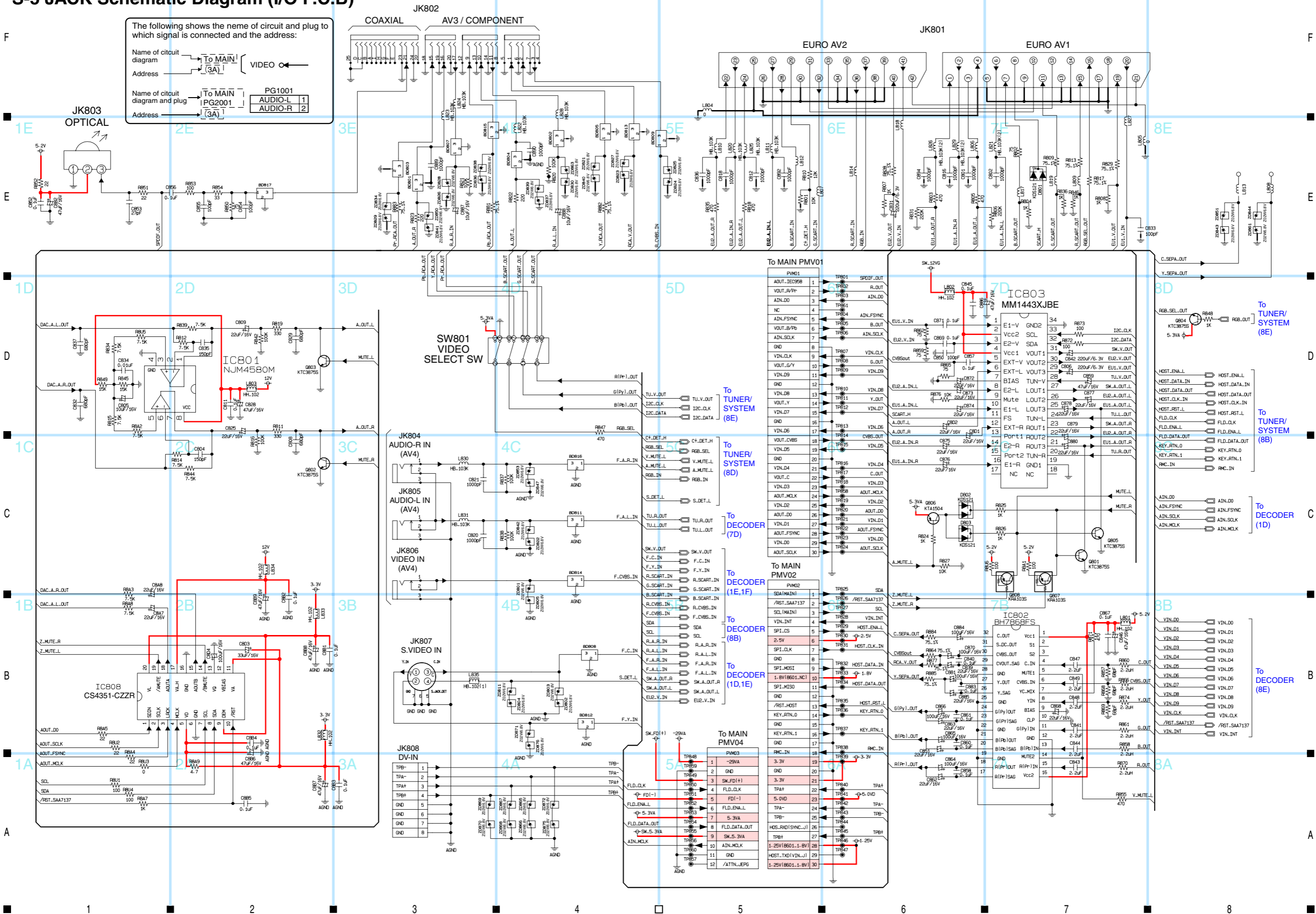

# S-6 DECODER Schematic Diagram (I/O P.C.B)

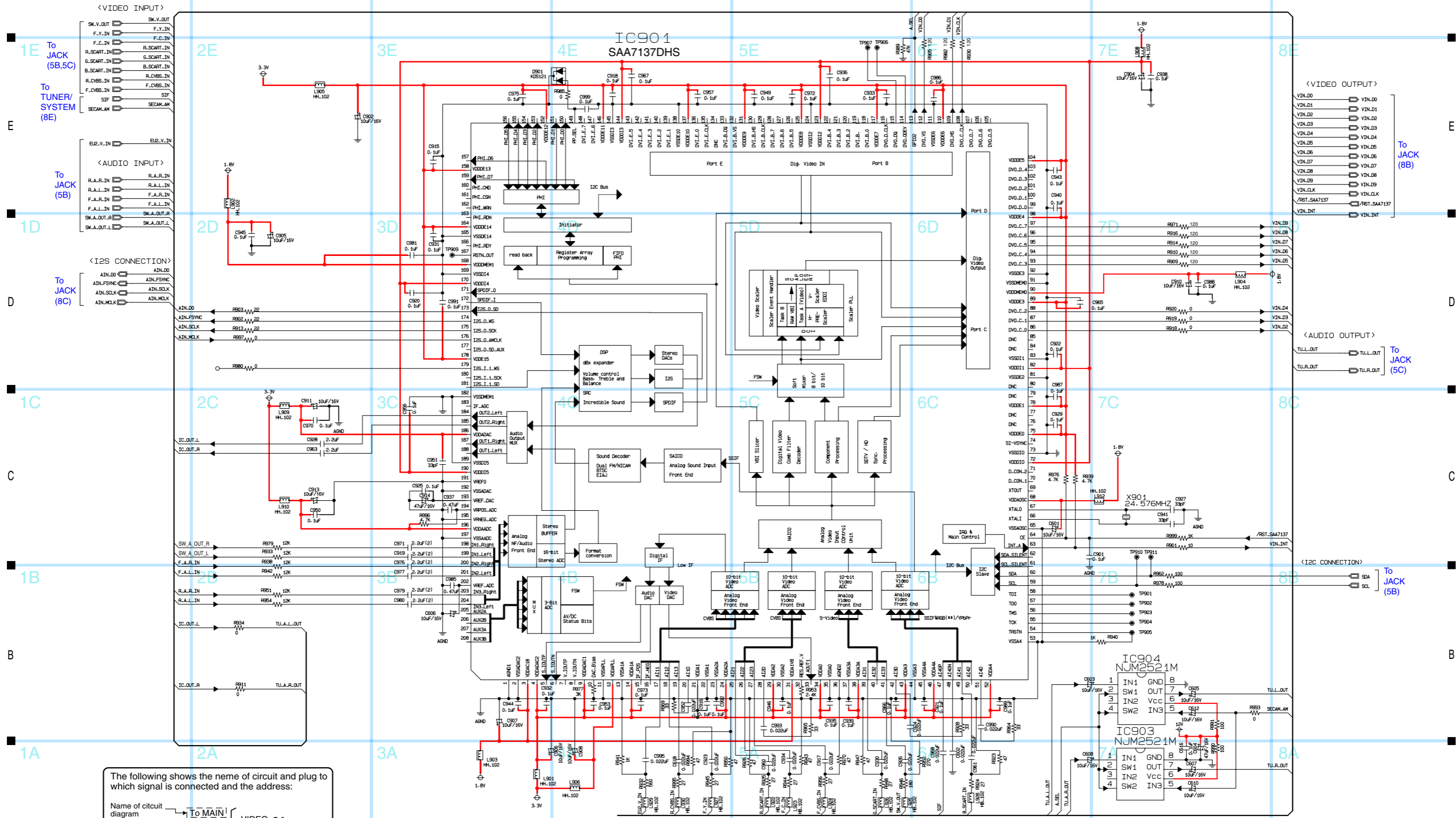

The following shows the name of circuit and plug to which signal is connected and the address:

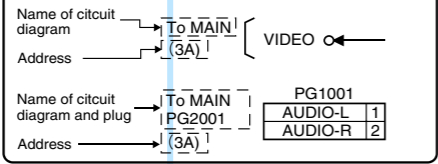

# S-7 TIMER-1, TIMER-2 Schematic Diagram (TIMER-1, TIMER-2 P.C.B)

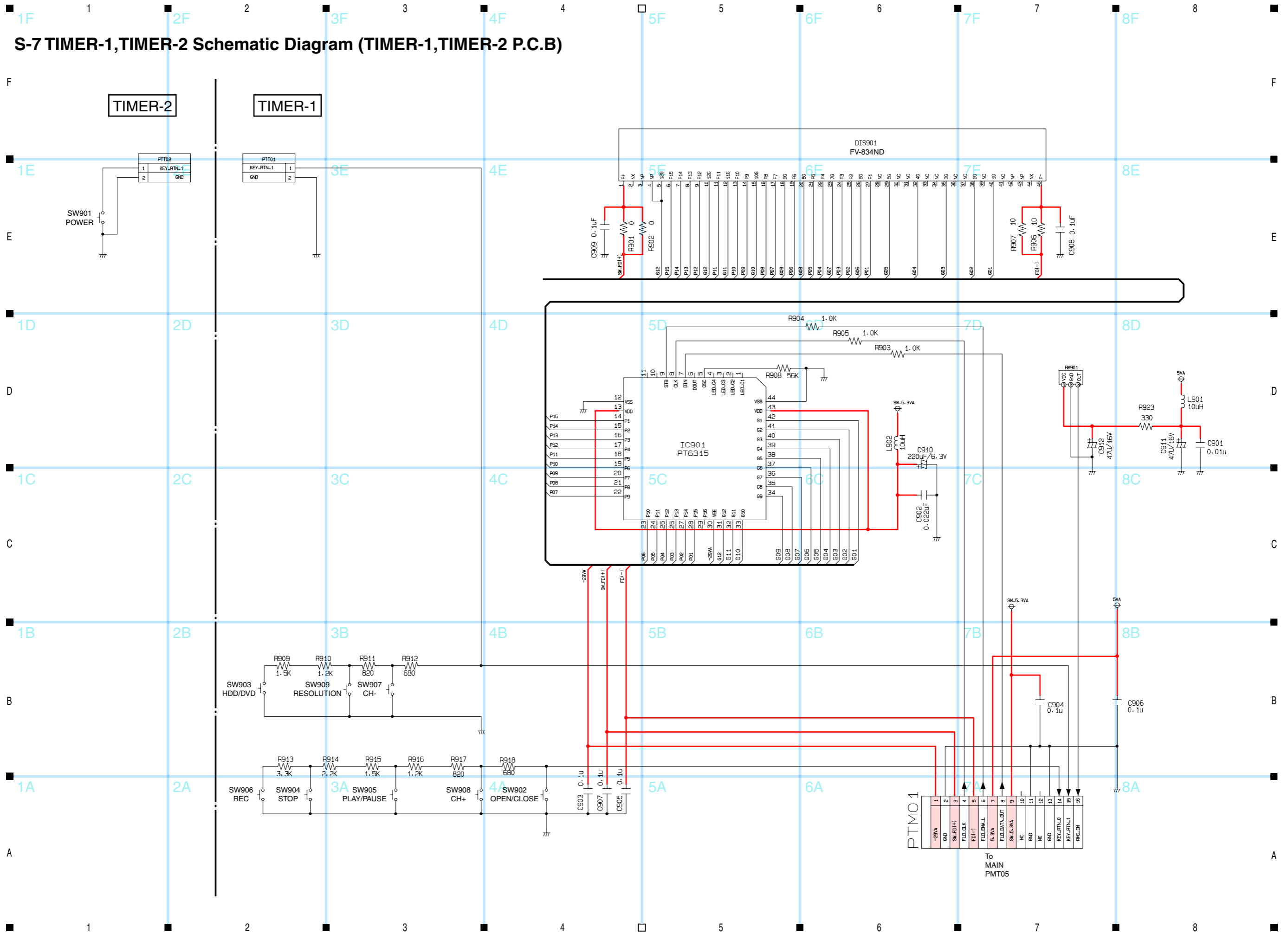

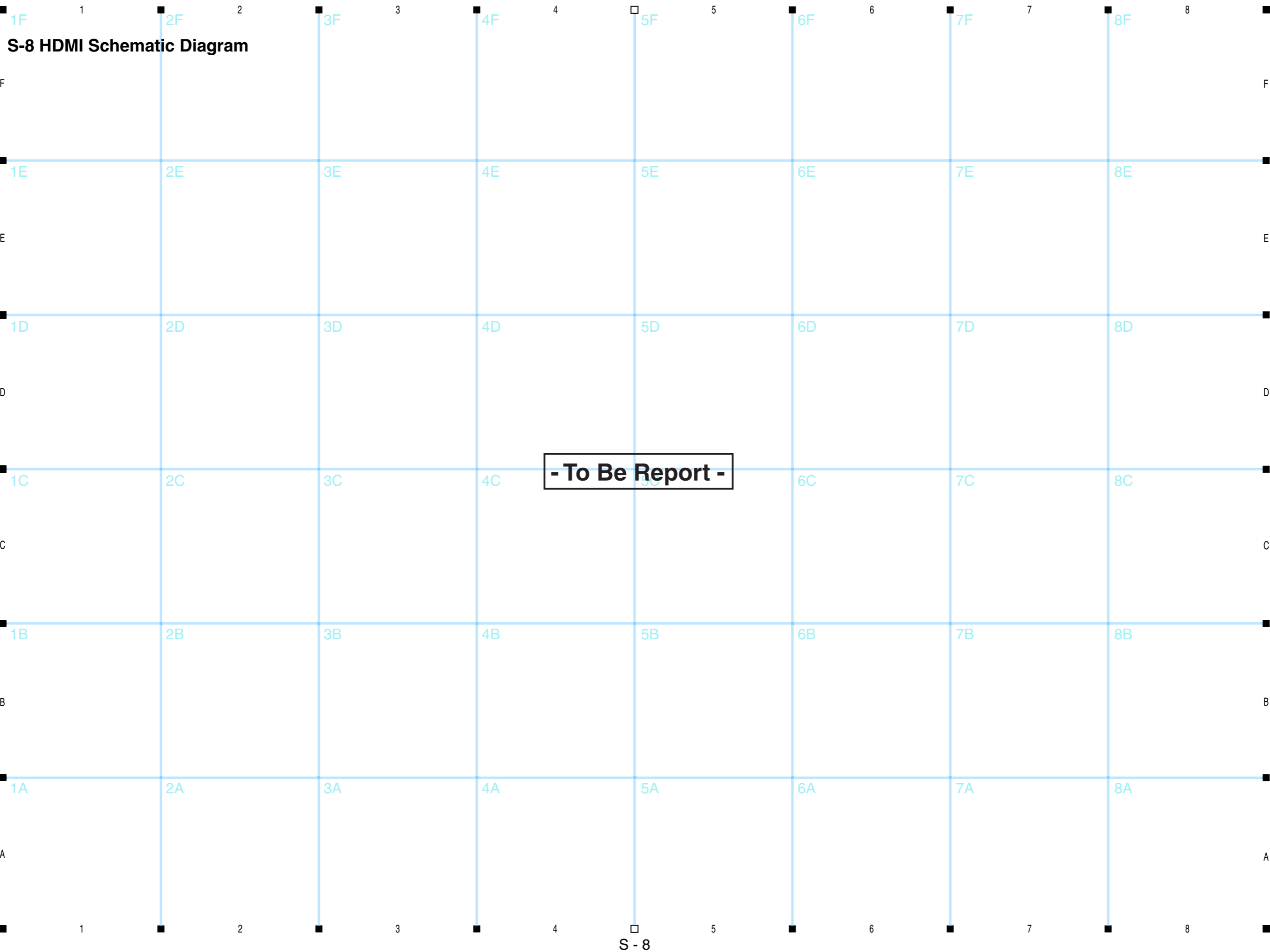

# S-9 Circuit Waveforms

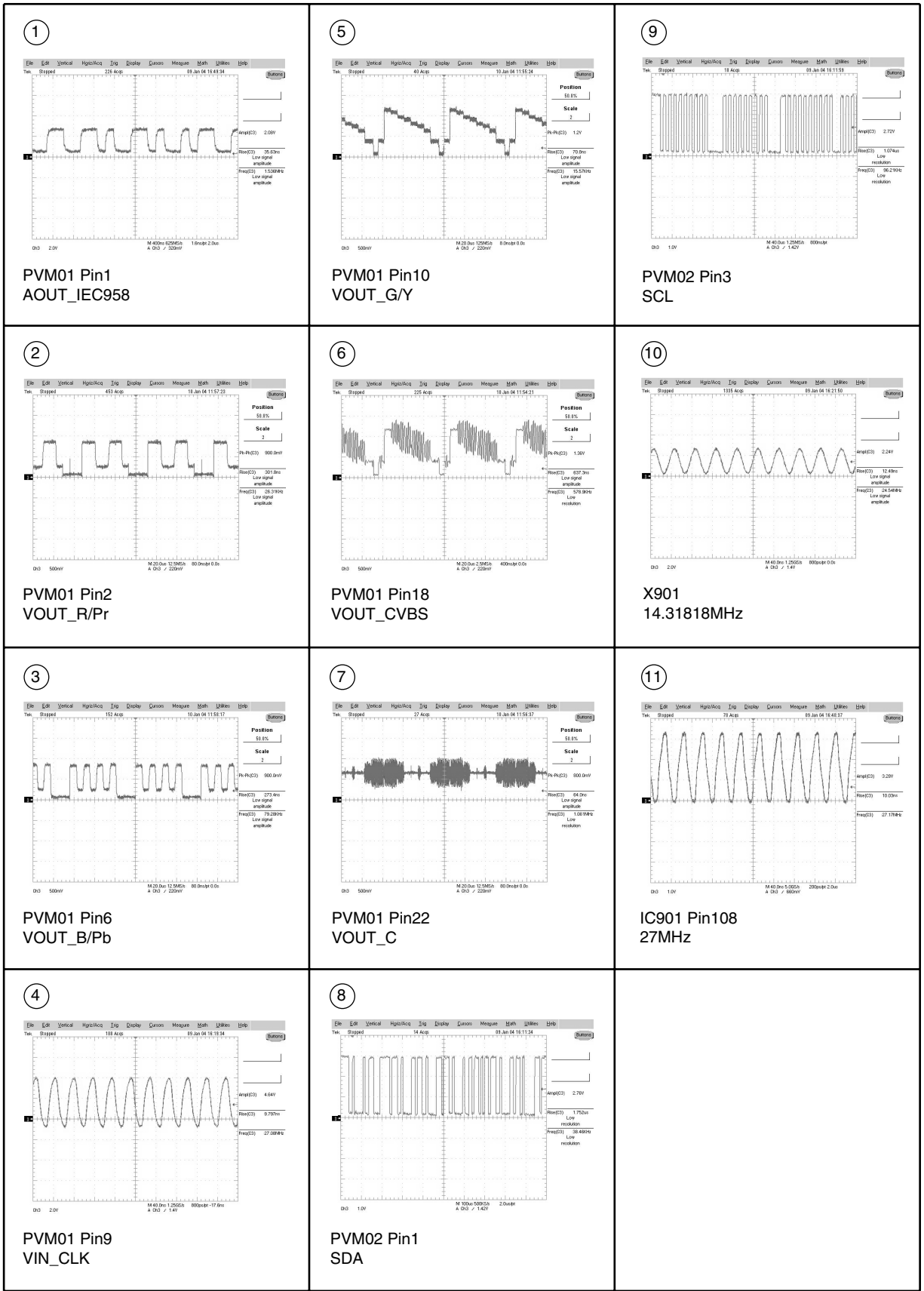



**C Circuit Board Diagrams**  
**C-1 I/O Circuit Board Diagram**

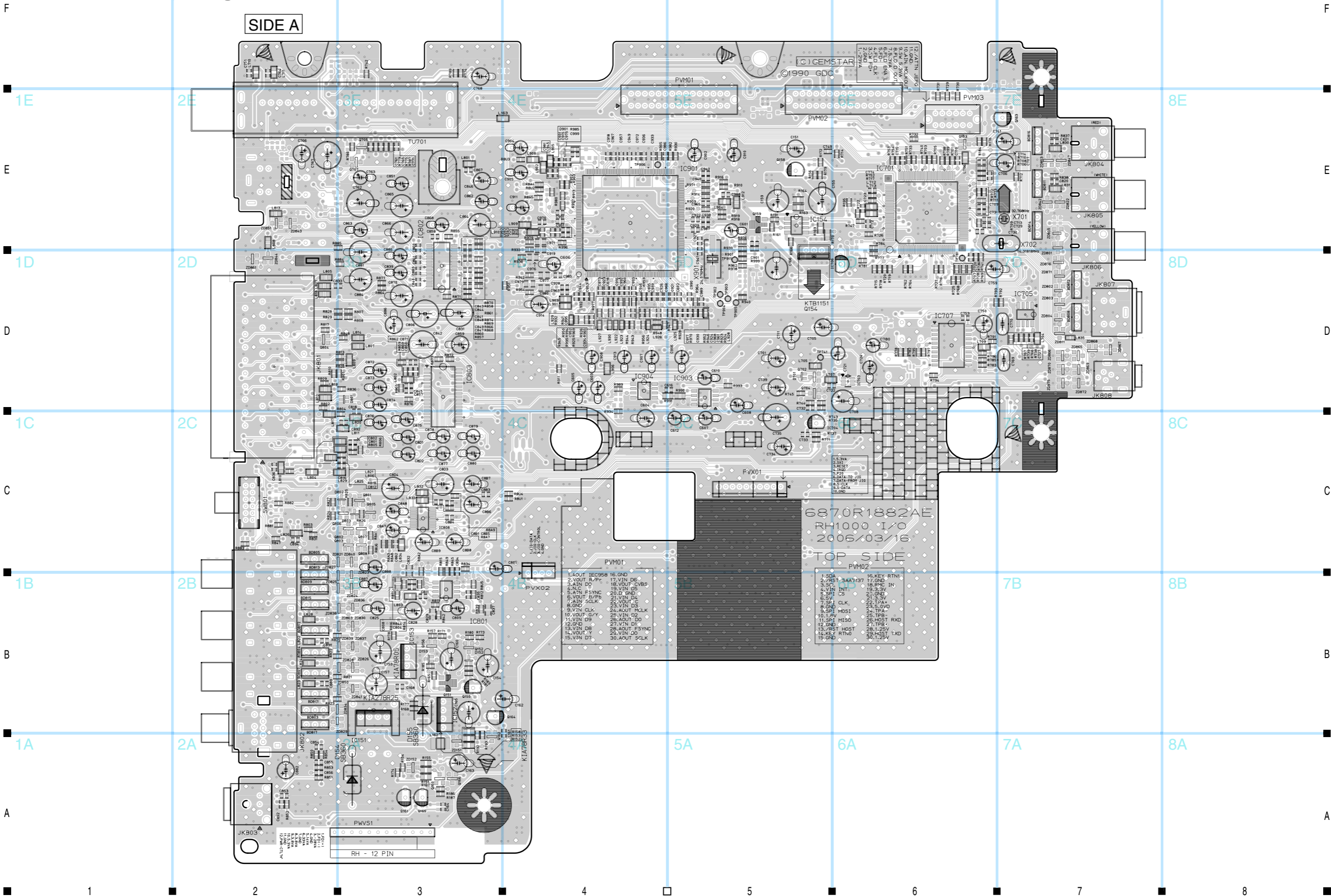

# I/O Circuit Board Diagram

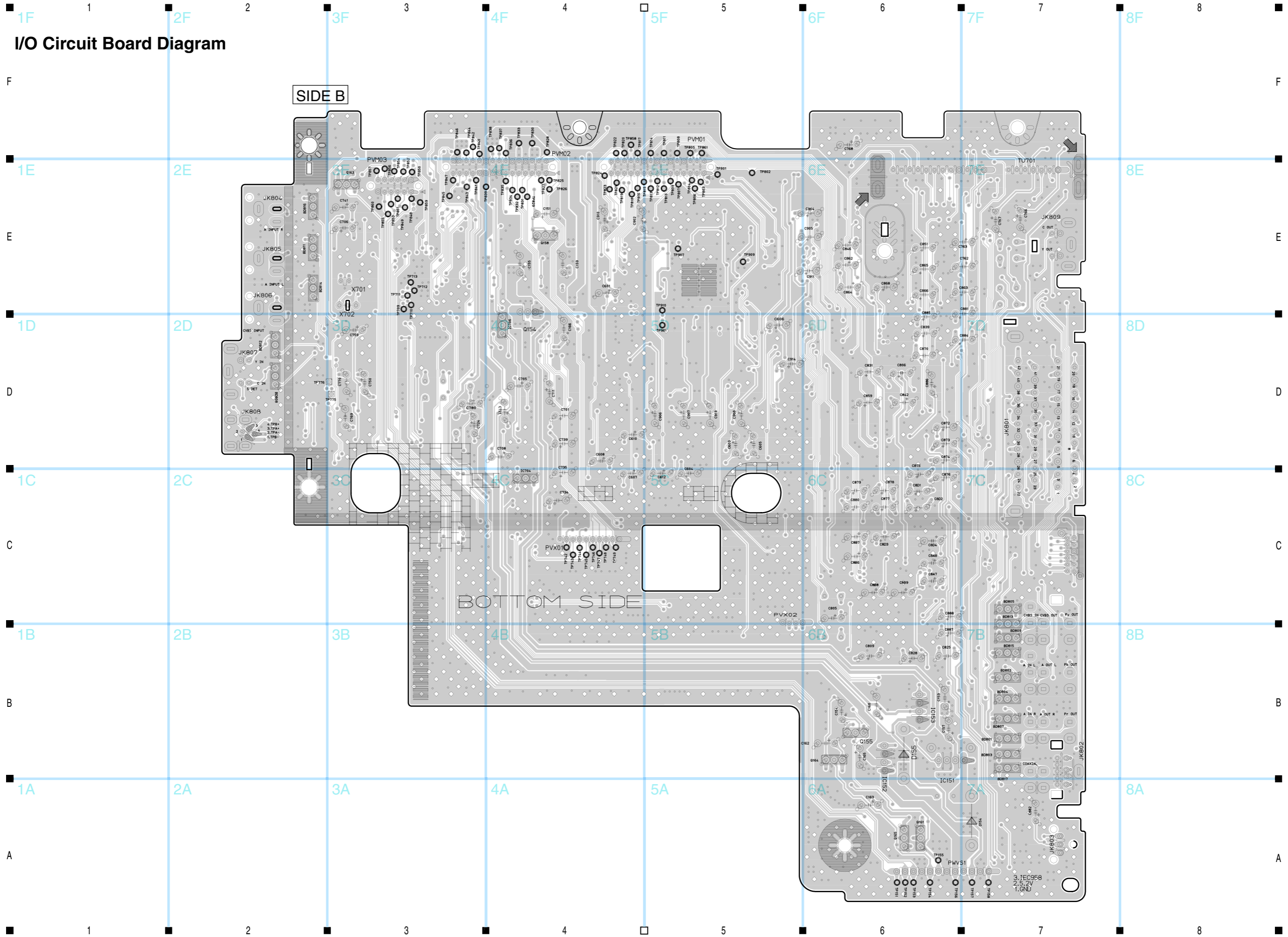



**C-2 SMPS Circuit Board Diagram, C-3 TIMER-1 Circuit Board Diagram, C-4 TIMER-2 Circuit Board Diagram**

**C-2 SMPS Board Diagram**

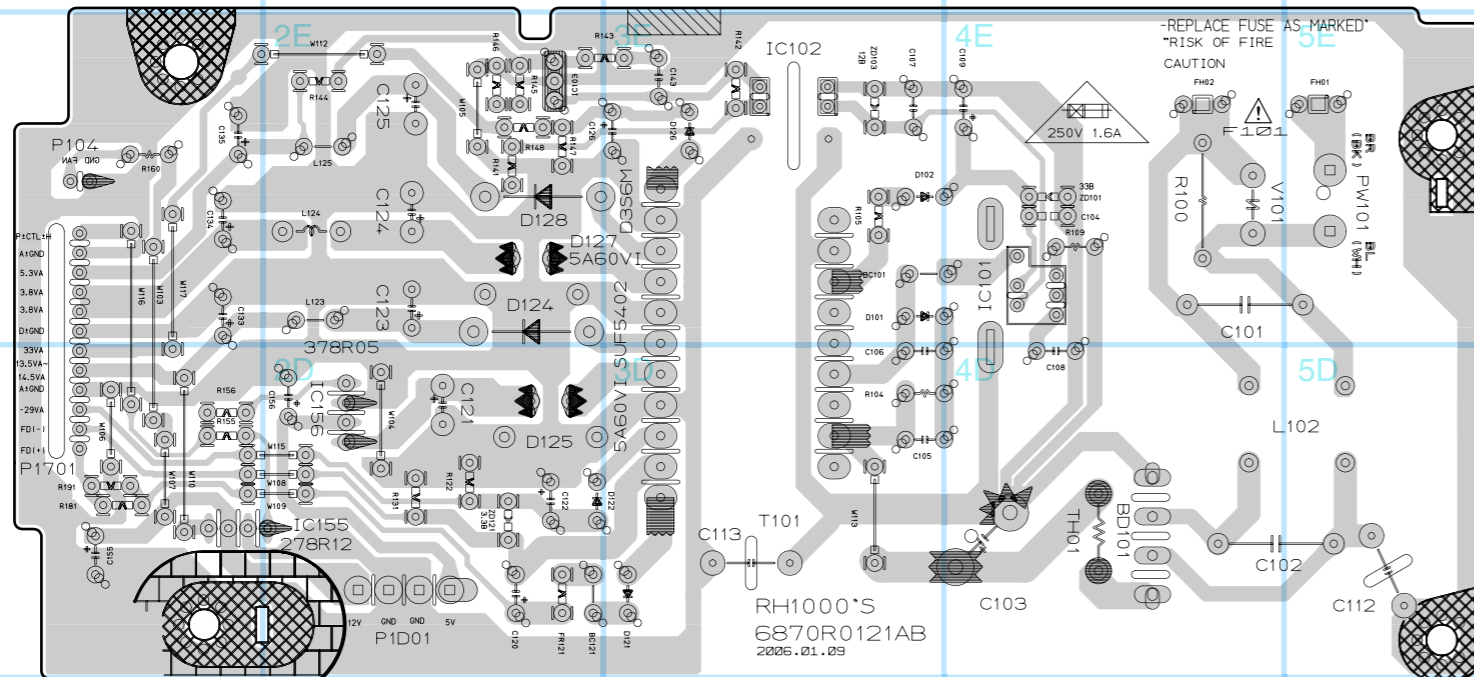

**C-4 TIMER-2 Circuit Board Diagram**

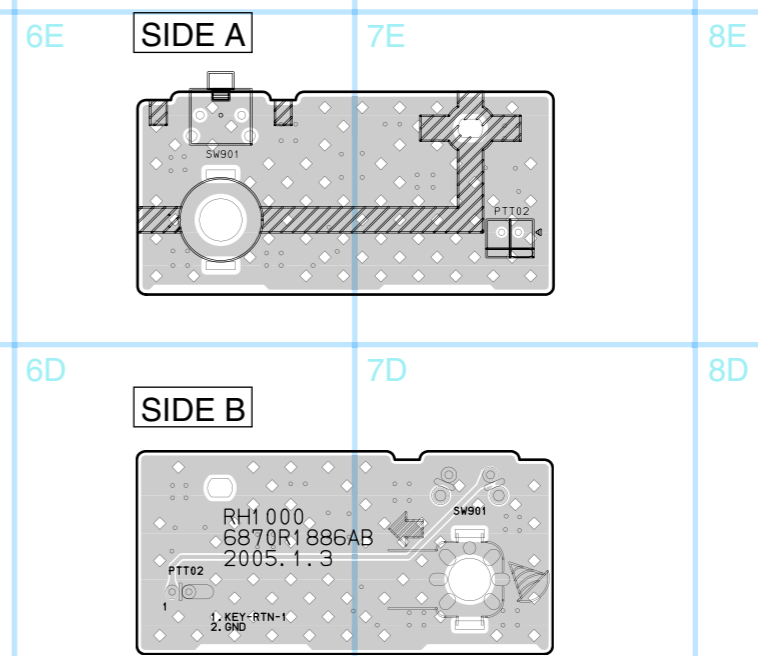

**C-3 TIMER-1 Circuit Board Diagram**

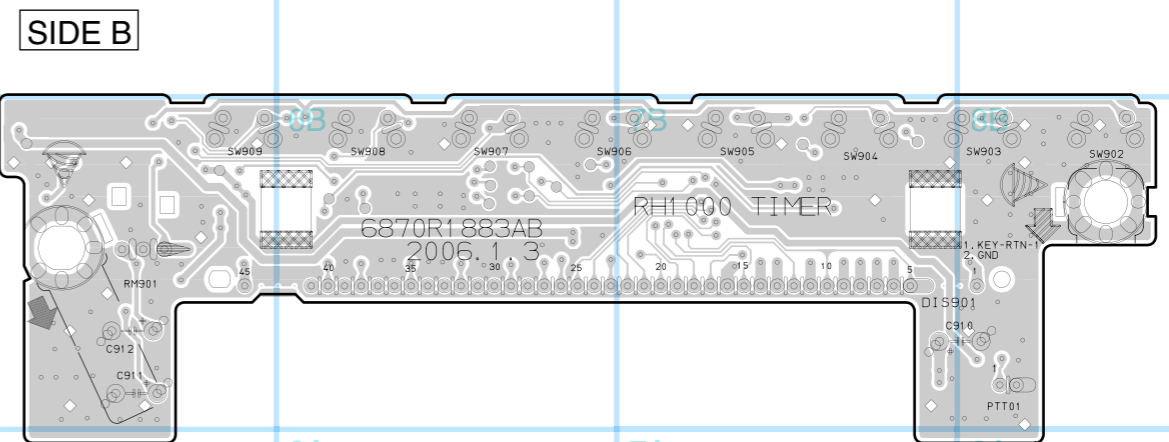
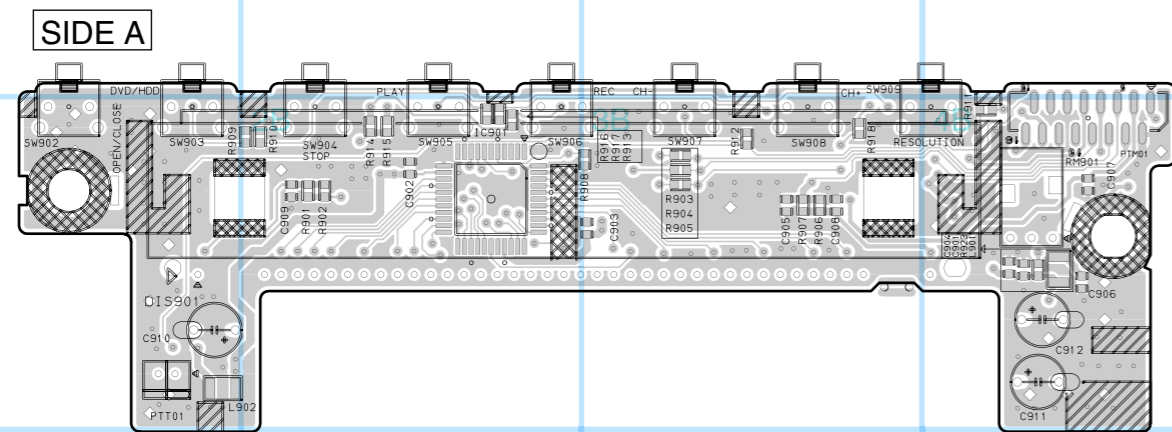

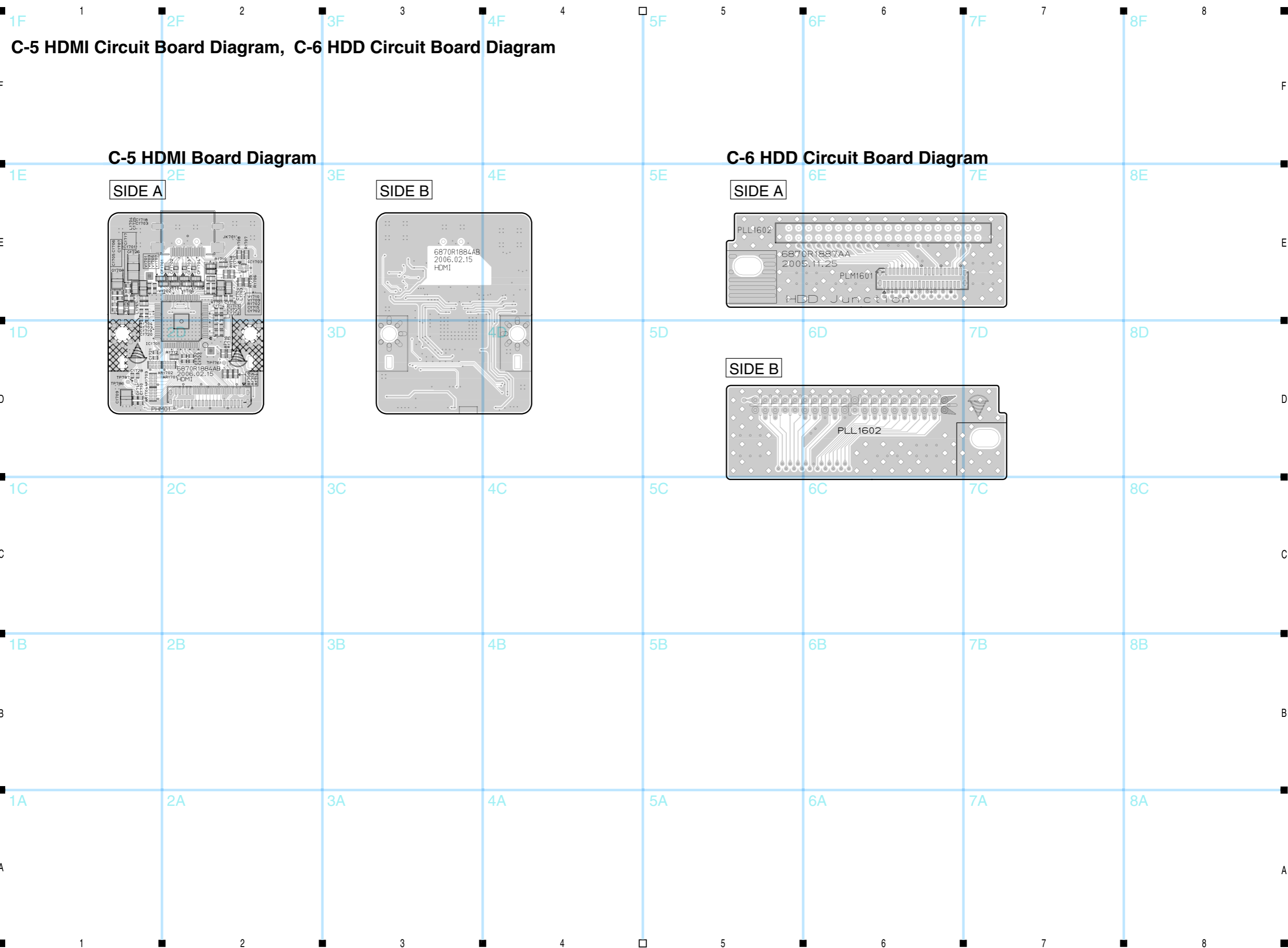

**C-5 HDMI Circuit Board Diagram, C-6 HDD Circuit Board Diagram**

**C-5 HDMI Board Diagram**

**C-6 HDD Circuit Board Diagram**

SIDE A

SIDE B

SIDE A

SIDE B

# B Block Diagrams

## B-1 Overall Block Diagram

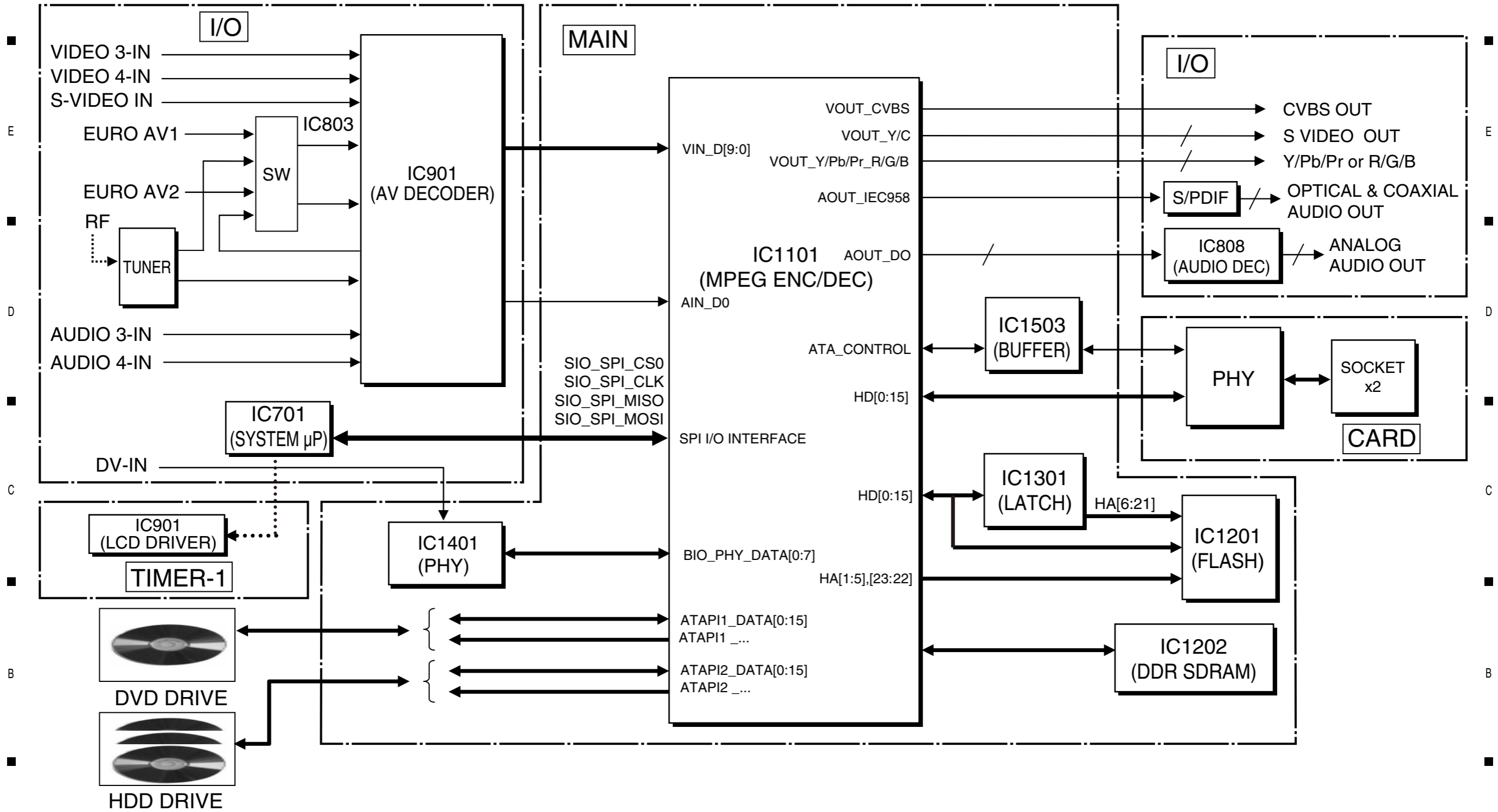

# B-2 SMPS Circuit Block Diagram

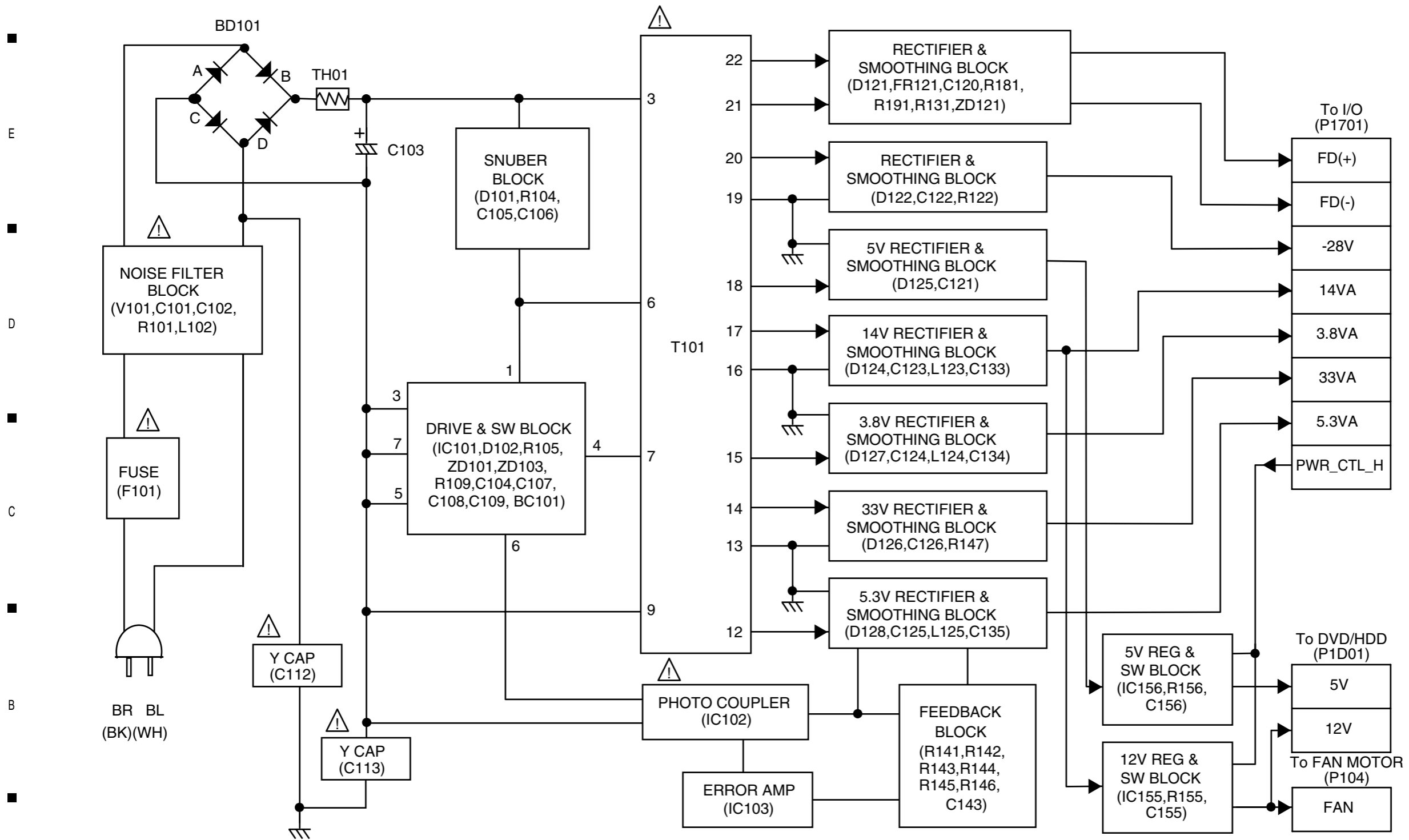

# B-3 POWER (I/O Board) Circuit Block Diagram

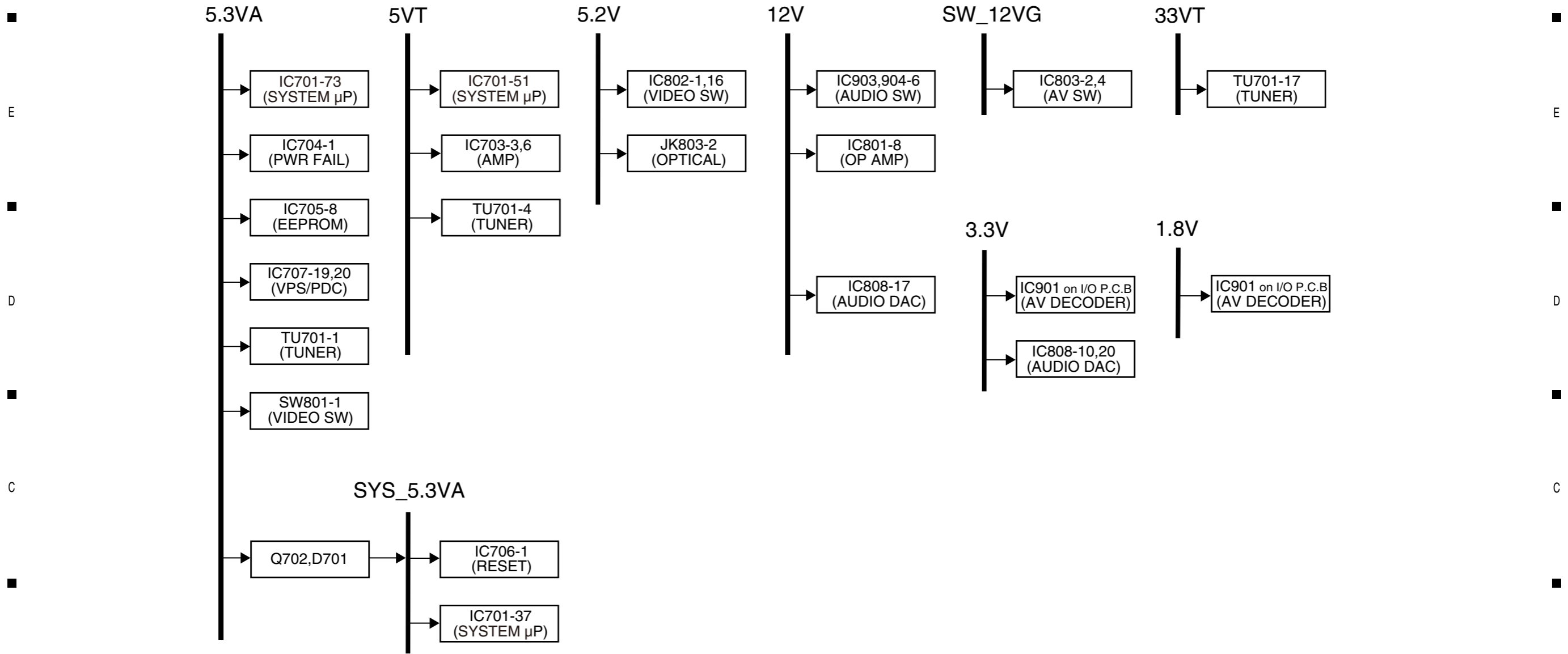

# B-4 AUDIO/VIDEO Circuit Block Diagram

F

F

E

E

D

D

C

C

B

B

A

A

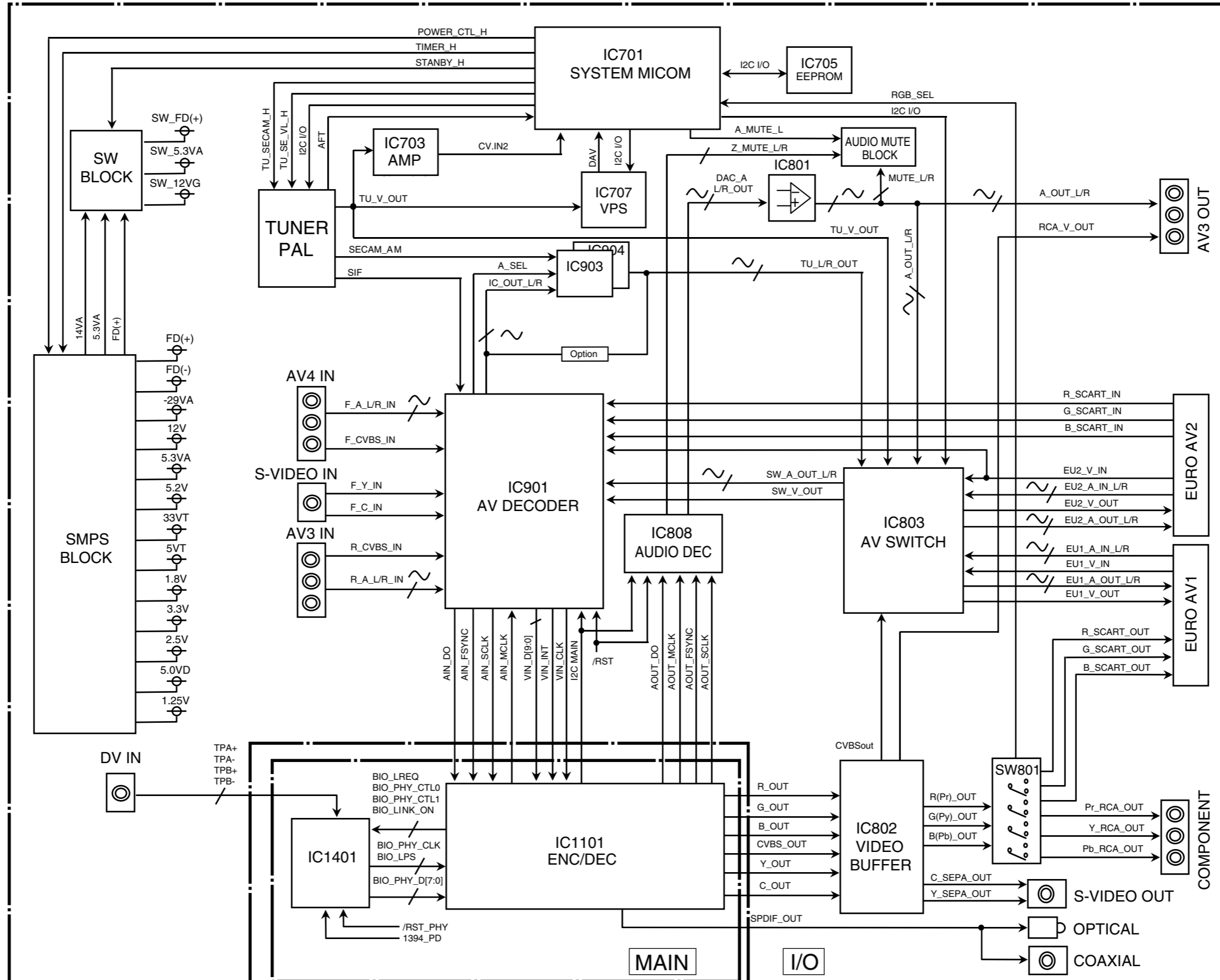

# B-5 SYSTEM Circuit Block Diagram

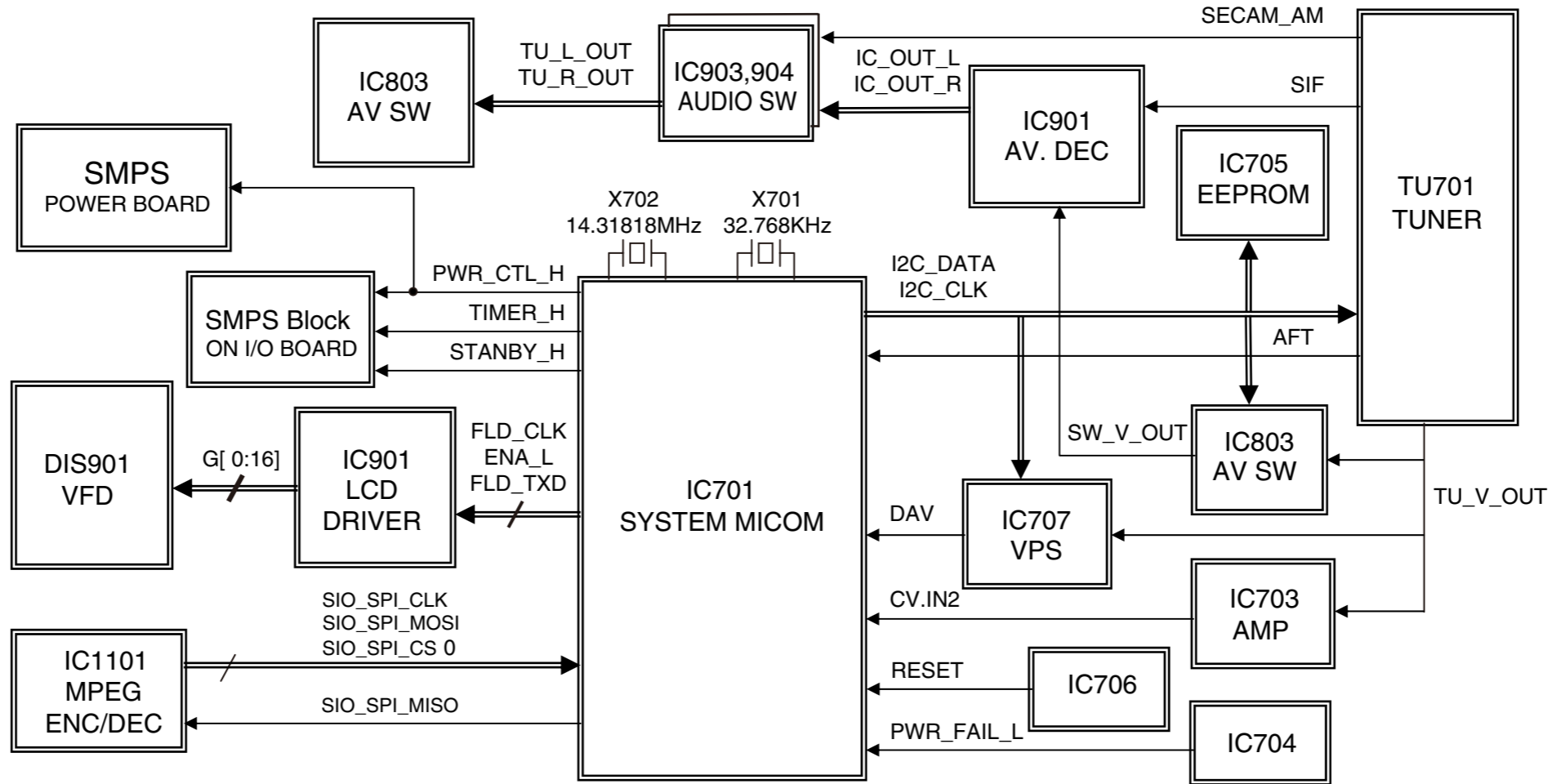

# HITACHI

Hitachi, Ltd. Tokyo, Japan  
International Sales Division  
**THE HITACHI ATAGO BUILDING,**  
No. 15-12 Nishi Shinbashi, 2 - Chome,  
Minato - Ku, Tokyo 105-8430, Japan.  
Tel: 03 35022111

## HITACHI EUROPE LTD,

Whitebrook Park  
Lower Cookham Road  
Maidenhead  
Berkshire  
SL6 8YA

## UNITED KINGDOM

Tel: 01628 643000  
Fax: 01628 643400  
Email: [consumer-service@hitachi-eu.com](mailto:consumer-service@hitachi-eu.com)

## HITACHI EUROPE S.A.

364 Kifissias Ave. & 1, Delfon Str.  
152 33 Chalandri  
Athens

## GREECE

Tel: 1-6837200  
Fax: 1-6835964  
Email: [service.hellas@hitachi-eu.com](mailto:service.hellas@hitachi-eu.com)

## HITACHI EUROPE GmbH

Munich Office  
Dornacher Strasse 3  
D-85622 Feldkirchen bei München

## GERMANY

Tel: +49-89-991 80-0  
Fax: +49-89-991 80-224  
Hotline: +49-180-551 25 51 (12ct/min)  
Email: [HSE-DUS.service@hitachi-eu.com](mailto:HSE-DUS.service@hitachi-eu.com)

## HITACHI EUROPE S.A.

Gran Via Carlos III, 86, planta 5  
Edificios Trade - Torre Este  
08028 Barcelona

## SPAIN

Tel: +34 93 409 2550  
Fax: +34 93 491 3513  
Email: [atencion.cliente@hitachi-eu.com](mailto:atencion.cliente@hitachi-eu.com)

## HITACHI EUROPE srl

Via Tommaso Gulli N.39, 20147  
Milano, Italia

## ITALY

Tel: +39 02 487861  
Tel: +39 02 38073415 Servizio Clienti  
Fax: +39 02 48786381/2  
Email: [customerservice.italy@hitachi-eu.com](mailto:customerservice.italy@hitachi-eu.com)

## HITACHI Europe AB

Box 77 S-164 94 Kista

## SWEDEN

Tel: +46 (0) 8 562 711 00  
Fax: +46 (0) 8 562 711 13  
Email: [csgswe@hitachi-eu.com](mailto:csgswe@hitachi-eu.com)

## HITACHI EUROPE S.A.S

Lyon Office  
B.P. 45, 69671 BRON CEDEX

## FRANCE

Tel: +33 04 72 14 29 70  
Fax: +33 04 72 14 29 99  
Email: [france.consommateur@hitachi-eu.com](mailto:france.consommateur@hitachi-eu.com)

## HITACHI EUROPE LTD (Norway) AB

STRANDVEIEN 18

1366 Lysaker

## NORWAY

Tel: 67 5190 30  
Fax: 67 5190 32  
Email: [csgnor@hitachi-eu.com](mailto:csgnor@hitachi-eu.com)

## HITACH EUROPE AB

Egebækgård  
Egebækvej 98  
DK-2850 Nærum

## DENMARK

Tel: +45 43 43 6050  
Fax: +45 43 60 51  
Email: [csgnor@hitachi-eu.com](mailto:csgnor@hitachi-eu.com)

## HITACHI EUROPE AB

Neopoli / Niemenkatu 73  
FIN-15140 Lahti

## FINLAND

Tel : +358 3 8858 271  
Fax: +358 3 8858 272  
Email: [csgnor@hitachi-eu.com](mailto:csgnor@hitachi-eu.com)

## Hitachi Europe Ltd

Bergensesteenweg 421  
1600 Sint-Pieters-Leeuw

## BELGIUM

Tel: +32 2 363 99 01  
Fax: +32 2 363 99 00  
Email: [sofie.van.bom@hitachi-eu.com](mailto:sofie.van.bom@hitachi-eu.com)

## HITACHI EUROPE LTD

Na Sychrove 975/8  
101 27 Praha 10 - Bohdalec

## CZECH REPUBLIC

Tel: +420 267 212 383  
Fax: +420 267 212 385  
Email: [csgnor@hitachi-eu.com](mailto:csgnor@hitachi-eu.com)

[www.hitachidigitalmedia.com](http://www.hitachidigitalmedia.com)