

HITACHI

SERVICE MANUAL

SM1515

DV-DS251E
DV-DS161E
DV-DS161EUK
DV-DS81E
DV-DS81EUK



DO NOT RESELL OR DIVERT IMPROPERLY

SPECIFICATIONS AND PARTS ARE SUBJECT TO CHANGE FOR IMPROVEMENT

HDD/DVD RECORDER

September 2005

Digital Media Division, YOKOHAMA

Table of Contents

1 Safety Precaution for Repair	1-1	(2) Front Panel	4-2
1-1 Cautions	1-1	(3) TIMER P.C.B, KEY P.C.B	4-2
1-2 Electrostatic Protection Measures	1-2	(4) SMPS P.C.B	4-3
1-3 Cautions When Handling DVD Drive	1-2	(5) JACK P.C.B	4-3
1-4 Cautions When Handling HDD	1-3	(6) HDD Unit	4-4
1-5 Lead-Free Solder	1-4	(7) CARD P.C.B	4-5
1-6 Notes When Using Service Manual	1-5	(8) MAIN P.C.B, PCB Frame	4-5
2 General Description	2-1	(9) I/O P.C.B, Rear Panel, FAN Motor	4-6
2-1 Overview	2-1	(10) DVD Multi Drive	4-7
2-1-1 Service method	2-1	5 Exploded View and Parts List.....	5-1
2-1-2 Disc information	2-2	5-1 Exploded View	5-1
2-2 Specifications	2-4	S Schematic, Wiring Diagrams	S-1
2-3 Major Differences from Previous Model ..	2-5	S-1 Wiring Diagram	S-1
2-4 Function Differences from Previous Model	2-6	S-2 SMPS Schematic Diagram	S-2
2-5 Names of Parts	2-7	S-3 SYSTEM Schematic Diagram(I/O P.C.B) ...	S-3
2-6 HDMI Connection	2-10	S-4 TUNER/JACK Schematic Diagram (I/O P.C.B)	S-4
2-7 List of Abbreviations and Terms for DVD Recorder	2-11	S-5 COMMERCIAL ADVANCE Schematic Diagram(I/O P.C.B)	S-5
3 Details of Servicing and Troubleshooting	3-1	S-6 JACK Schematic Diagram	S-6
3-1 How to Remove Disc from Faulty Recorder	3-1	S-7 TIMER,KEY Schematic Diagrams	S-7
3-1-1 Removing Disc without Opening Case ..	3-1	S-8 CARD-1 Schematic Diagram (CARD P.C.B)	S-8
3-1-2 Removing Disc from Faulty Recorder ..	3-2	S-9 CARD-2 Schematic Diagram (CARD P.C.B)	S-9
3-2 Details of Servicing	3-2	S-10 Circuit Waveforms	S-10
3-2-1 Setting to defaults at the factory	3-2	S-11 Circuit Voltage Chart	S-11
3-2-2 Troubleshooting HDD	3-3	C Circuit Board Diagrams	C-1
3-2-3 Firmware	3-4	C-1 I/O Circuit Board Diagram	C-1
(1) Version check procedure	3-4	C-2 SMPS Circuit Board Diagram	C-2
(2) Main firmware updating procedure	3-5	C-3 JACK Circuit Board Diagram	C-2
(3) Loader firmware updating procedure	3-6	C-4 LOADER Circuit Board Diagram	C-2
(4) Main/Loader firmware simultaneous updating procedure	3-6	C-5 HDD Circuit Board Diagram	C-2
3-3 Troubleshooting	3-7	C-6 TIMER Circuit Board Diagram	C-3
3-3-1 Troubleshooting electronic system	3-7	C-7 KEY Circuit Board Diagram	C-3
4 Disassembly and Reassembly	4-1	C-8 CARD Circuit Board Diagram	C-3
4-1 Order of Disassembly	4-1		
4-2 Disassembly	4-1		
(1) Top Cover	4-1		

B Block Diagrams	B-1
B-1 Overall Block Diagram	B-1
B-2 SMPS Circuit Block Diagram	B-2
B-3 POWER(I/O Board) Circuit Block Diagram	B-3
B-4 AUDIO/VIDEO Circuit Block Diagram	B-4
B-5 SYSTEM Circuit Block Diagram	B-5
B-6 COMMERCIAL ADVANCE Circuit Block Diagram	B-6

1

Safety Precaution for Repair

1-1 Cautions

PRODUCT SAFETY NOTICE

Many electrical and mechanical parts have special safety-related characteristics. These are often not evident from visual inspection nor can the protection afforded by them necessarily be obtained by using replacement components rated for a higher voltage, wattage, etc. Replacement parts which have these special safety characteristics are identified in this Service Manual. Electrical components having such features are identified by marking with a **⚠** on the schematics and the parts list in this Service Manual. The use of a substitute replacement component which does not have the same safety characteristics as the HITACHI recommended replacement one, shown in the parts list in this Service Manual, may create shock, fire, or other hazards. Product safety is continuously under review and new instructions are issued from time to time. For the latest information, always consult the current HITACHI Service Manual. A subscription to, or additional copies for, HITACHI Service Manual may be obtained at a nominal charge from HITACHI SALES CORPORATION.

CLASS 1 LASER PRODUCT
KLASSE 1 LASER PRODUKT
LUOKAN 1 LASER LAITE
KLASS 1 LASER APPARAT
CLASSE 1 PRODUIT LASER

CAUTION

This product contains a laser diode of higher class than 1. To ensure continued safety, do not remove any covers or attempt to gain access to the inside of the product. Refer all servicing to qualified personnel.

CAUTION

There is a high-voltage section inside the DVD video recorder. When repairing or inspecting it, take great care to prevent electric shock: Use an isolating transformer, wear gloves, etc.

1-2 Electrostatic Protection Measures

Semiconductor components can be damaged by static electricity charged on clothes, human body, etc. Take great care when handling components to avoid electrostatic damage, and perform servicing in an environment where grounding is complete.

(1) Grounding work bench

Lay out an antistatic mat on work bench, and then use the ground plate to ground the work bench.

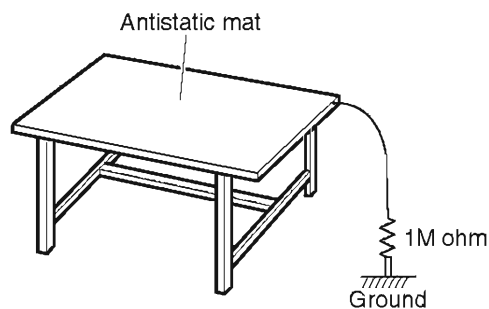

(2) Grounding human body

Use an antistatic wrist strap to discharge any static electricity charged on the body. Also, use a tester for wrist strap to make sure that the wrist strap is working normally. Note, however, that static electricity charged on clothes will not be discharged by wrist strap: Therefore do not allow your clothes to touch the semiconductor components.

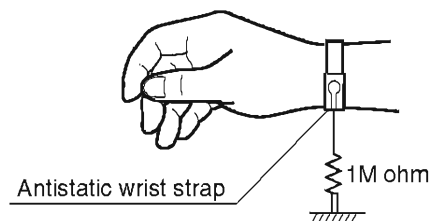

1-3 Cautions When Handling DVD Drive

The optical pickup in DVD drive has a high precision structure: Be sure to observe the following cautions.

- 1) Do not subject optical pickups to any severe vibrations or impact during movement, installation or disassembly.
- 2) When performing repair work, do not perform disassembly any further than that described in this manual.
- 3) Never turn the semi-variable resistors for adjustment in optical pickup or DVD drive.
- 4) NEVER look into the objective lens in optical pickup or directly view the laser light: You could lose your eyesight.

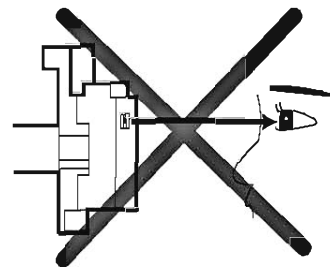

Do not directly look at laser light from pickup.

1-4 Cautions When Handling HDD (Hard Disk Drive)

HDD is a high precision device, and is very susceptible to vibrations or impact. Even if HDD operates normally immediately after it has been subjected to vibrations or impact, a problem may occur after it is used for a while. When servicing, take great care with the following.

There are two types of HDD: CSS format (head remains on disk regardless of operation status) and ramp loading format (head moves away from disk during no operation). The impact resistance characteristics are slightly different for the two. When servicing, observe the following cautions regardless of the format:

(1) Cautions during unpacking

- 1) Do not subject the HDD to any impact when placing on desk: The head hitting against the desk could result in damage.
- 2) If condensation occurs because of the environment, leave the HDD without being turned on for at least 3 hours until it adapts to surrounding environment. If the HDD is turned on while the head is sticking to disk because of condensation, the disk may be damaged.

(2) Cautions during transportation

An HDD is more susceptible to vibrations or impact when it is turned on or operating than during no operation.

- 1) Do not move the HDD while it is turned on: If the HDD is subject to any impact while the disk is rotating, i.e., the head hitting against the disk, breakage could result.
- 2) Move the HDD approximately 2 minutes (approximately 30 seconds for surveillance system devices) after turning it off and unplugging its power cord from AC outlet. The disk will still be rotating by inertia immediately after the HDD is turned off: Subjecting the HDD to movement at this time could destroy it.

(3) Cautions during operation

- 1) Do not unplug the power cord from AC outlet during operation: This could damage the data on HDD. Be sure to turn the HDD off before unplugging the power cord.
- 2) Do not hit the HDD: The head hitting the disk could result in breakage.

(4) Caution during packing

- 1) Use the packing material of relevant model: Material superior in impact resistance is used. Using other packing materials could result in fault.

(5) Cautions when handling unassembled HDD

- 1) Hold the HDD at both sides so that the circuit board surface is facing below: Holding the HDD at the top and bottom could cause the head to drift, which could result in fault.
- 2) Do not touch the terminal or pattern on circuit board.
- 3) Place HDD on a spot where cushion is pasted with the circuit board surface facing below.
- 4) Do not hold or place stacked HDDs.
- 5) Do not drop or hit HDD against anything: Dropping HDD from even 5 mm high on a work bench with high stiffness could cause fault.

1-5 Lead-Free Solder

The printed circuit board that uses lead-free solder is adopted. To protect the global environment, use the recommended lead-free solder also during servicing.

Read and observe the following before soldering:

Caution

ALWAYS wear protective goggles during soldering so that no solder smoke or scattered solder enters the eye. Lead-free solder may scatter at high temperatures of 600°C.

(1) Characteristics of lead-free solder

The melting point of lead-free solder is 30-40°C higher than that of lead based solder.

(2) Lead-free solder for servicing

Use the following lead-free solder for servicing:

Recommended lead-free solder and composition of alloy (wt%): Sn-3.0Ag-0.5Cu or equivalent

Information:

For composition of alloy, Sn is tin; Ag is silver; Cu is copper; Bi is bismuth; Pb is lead.

(3) Soldering iron for servicing

The temperature of soldering iron tip must be adjusted according to the points to be soldered: Use an antistatic soldering iron with thermal control function.

When removing components, take care not to damage any surrounding component or pattern. When attaching components, observe the heating time in the following table so that the components are not destroyed by heat.

Tip temperatures for different soldering points:

Point to be soldered	Tip temperature
Surface-mounted (chip) parts [other than those shown below]	320 ± 30°C [heating time: less than 5 seconds]
Surface-mounted (chip) parts [for DVD cameras, cellular phones only]	350 ± 10°C [heating time: less than 3 seconds]
Discrete parts	380 ± 30°C
Chassis, metal shield, etc.	420 ± 30°C

(4) Cautions when using lead based solder

It is recommended that you use lead-free solder when servicing, but it is also possible to service using lead based solder. However, if lead based solder is used for servicing, take care with the following:

- 1) Before using lead based solder, remove the lead-free solder completely from the point to be soldered.
- 2) For additional soldering for repair, set the soldering iron tip temperature for lead-free solder, mix lead based solder and lead-free solder sufficiently. Do not perform any repair using the bare soldering iron tip without adding solder, since it will cause secondary failure due to lack of strength.

1-6 Notes When Using Service Manual

(1) Value units used in parts list

Certain symbols are indicated as shown below for value units of resistors, capacitors and coils in parts list. When you read them, note the following regular indications:

Parts	Indication in list	Regular indication
Resistor	KOHM	k Ω
Capacitor	UF	μ F
	PF	pF
Coil	UH	μ H
	MH	mH

(2) Values in schematic diagrams

The values, dielectric strength (power capacitance) and tolerances of the resistors (excluding variable resistors) and capacitors are indicated in the schematic diagrams using abbreviations.

Certain symbols are indicated for value units: When you read them note the regular indications in tables below:

[Resistors]

Item	Indication
Value	No indication Ω
	K k Ω
	M M Ω
Tolerance	No indication $\pm 5\%$ (All tolerances other than $\pm 5\%$ are indicated in schematic diagrams)
Power capacitance	No indication 1/8W (1/16 W for leadless resistors with no indication) All capacitances other than the above are indicated in schematic diagrams.

[Capacitors]

Item	Indication
Value	No indication μ F
	P pF
Dielectric strength	No indication 50V (All dielectric strengths other than 50 V are indicated in schematic diagrams)

[Coils]

Item	Indication
Value	μ μ H
	m mH

2

General Description

2-1 Overview

The HDD/DVD recorder models DV-DS251E, DS161E and DS81E all incorporate 250-GB, 160-GB and 80-GB HDDs, made by Hitachi Global Storage Technologies.

The DVD recorder block contains a DVD multi-drive. It is compatible with recording and playback of a variety of media – 5x DVD-RAM, 4x DVD-RW, 16x DVD-R, DVD+RW, DVD+R and DVD+R DL.

2-1-1 Service method

Basically, components are replaced when servicing the HDD/DVD recorder. However, the service method is different for high-density packaging PCBs and precision components.

Refer to the following table and perform the designated, appropriate servicing. Any changes that occur in the service method will be published using service bulletin, etc.

Do not perform any servicing other than that described in this manual.

Component	Service method
Exterior component	Component replacement
DVD Multi Drive	Unit replacement
HDD Unit	Unit replacement
MAIN P.C.B	Circuit board assembly replacement
I/O P.C.B	Component replacement
SMPS P.C.B	Component replacement
TIMER P.C.B	Component replacement
JACK P.C.B	Component replacement
KEY P.C.B	Component replacement
CARD P.C.B	Component replacement

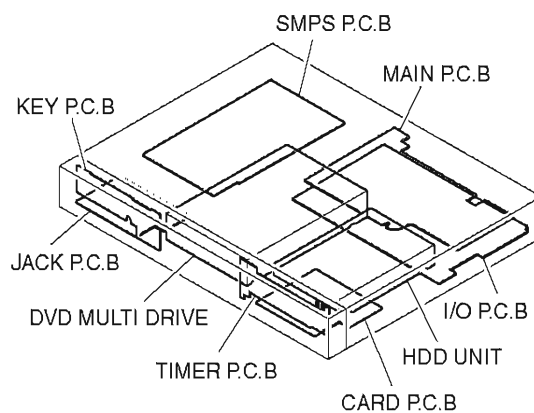

Fig. 2-1-1 Component Location

2-1-2 Disc information

Recordable and Playable Discs



DVD-RW

- DVD-RW discs can be formatted for VR mode recording or Video mode recording.
- These Discs can be recorded on repeatedly. Recordings can be erased, then you can record again on the same Disc.

[VR mode]

- Recordings can be extensively edited
- Playable only on VR mode compatible players (after finalization)

[Video mode]

- Playable on regular DVD players (after finalization)
 - Limited editing features
-



DVD-R

- These Discs can be recorded only once. After you finalize a DVD-R, you cannot record on it or edit it.
 - DVD-R discs can be only formatted to Video mode.
 - Playable on regular DVD players (after finalization).
 - Limited editing features
-



DVD-RAM

- DVD-RAM discs can be formatted for VR mode recording.
 - These Discs can be recorded on repeatedly. Recordings can be erased, then you can record again on the same Disc.
 - Playable on DVD-RAM compatible players.
 - Recordings can be extensively edited.
 - Only DVD-RAM standard Version 2.0, 2.1 and 2.2 discs can be used in this unit.
 - You cannot use the cartridge-type DVD-RAM disc in this unit.
-



DVD+RW

- These Discs can be recorded on repeatedly. Recordings can be erased, then you can record again on the same Disc.
 - Playable on DVD+RW compatible players (automatically finalization)
 - The edited contents are playable on DVD+RW compatible players only after finalization
 - Recordings can be edited the title/chapter
-



DVD+R

- These Discs can be recorded only once. After you finalize a DVD+R, you cannot record on it or edit it any more.
 - Playable on DVD+R compatible players (after finalization)
 - Any edited contents are not be compatible on DVD+R compatible players. (Hide, chapter combine, added chapter mark, etc.)
 - Limited title/chapter editing features.
-



DVD+R DL

- These Discs can be recorded only once. After you finalize a DVD+R DL, you cannot record on it or edit it any more.
 - Storage space is nearly doubled with double layer DVD+R media, allowing consumers to record up to 8.5GB of video on a single DVD+R DL disc.
 - Playable on DVD+R compatible players (after finalization)
 - Any edited contents are not be compatible on DVD+R DL compatible players. (Hide, chapter combine, added chapter mark, etc.)
 - Limited title/chapter editing features.
-

The recordable DVD discs (Example)

DVD-R	DVD+R	DVD-RW	DVD+RW	DVD+R (DL)	DVD-RAM
Maxell (4x, 8x)	Maxell (4x, 8x)	Maxell (1x, 2x, 4x)	Maxell (2.4x, 4x)	Maxell (2.4x)	Maxell (3x, 5x)
SONY (8x, 16x)	SONY (2.4x, 4x, 8x, 16x)	Victor (1x, 4x)	TDK (2.4x)	Mitsubishi (2.4x)	-
TDK (4x, 8x)	TDK (4x)	TDK (2x)	Philips (4x)	-	-
Verbatim (4x, 8x)	Mitsubishi (4x, 8x)	Mitsubishi (2x)	Ricoh (2.4x)	-	-
Panasonic (2x, 4x)	Ricoh (2x, 4x, 8x)	-	HP (2.4x, 4x)	-	-

Note:

If a DVD-RW/DVD+RW disc is recorded using a personal computer or other DVD recorder, you cannot format the disc using this recorder. So if you want to use the disc on this recorder, you must format the disc using the original recorder.

The above discs were checked for usability in 2005.

Disc specifications may be changed without notice.

Playable Discs



DVD (8 cm / 12 cm disc)

- Discs such as movies that can be purchased or rented



Video CD (VCD) (8 cm / 12 cm disc)

- VIDEO CDs or CD-Rs/CD-RWs in VIDEO CD/Super VIDEO CD format



Audio CD (8 cm / 12 cm disc)

- Music CDs or CD-Rs/CD-RWs in music CD format that can be purchased



CD-R/CD-RW (8 cm / 12 cm disc)

- CD-R/CD-RW discs that contain audio titles, DivX®, MP3, WMA, or JPEG files.

Notes:

- Depending on the conditions of the recording equipment or the CD-R/RW (or DVD±R/RW) disc itself, some CD-R/RW (or DVD±R/RW) discs cannot be played on the unit.
- Do not attach any seal or label to either side (the labeled side or the recorded side) of a disc.
- Do not use irregularly shaped CDs (e.g., heart-shaped or octagonal). Doing so may result in malfunctions.
- Depending on the recording software & the finalization, some recorded discs (CD-R/RW or DVD±R/RW) may not be playable.
- DVD-R/RW, DVD+R/RW and CD-R/RW discs recorded using a personal computer or a DVD or CD Recorder may not play if the disc is damaged or dirty, or if there is dirt or condensation on the Recorder's lens.
- If you record a disc using a personal computer, even if it is recorded in a compatible format, there are cases in which it may not play because of the settings of the application software used to create the disc. (Check with the software publisher for more detailed information.)

2-2 Specifications

General

Power requirements	AC 220-240V, 50/60 Hz
Power consumption	35W
Dimensions (approx.)	432 X 60.5 X 371.5 mm (w x h x d)
Mass (approx.)	5.6 kg
Operating temperature	5°C to 35°C
Operating humidity	10 % to 80 %
Television system	PAL B/G, SECAM L/L' colour system [For E] PAL I/II colour system [For E(UK)]
Recording format	PAL

Recording

Recording format	DVD Video Recording, DVD-VIDEO
Recordable media	HDD, DVD-RW, DVD-R, DVD+RW, DVD+R, DVD+R (Double Layer), DVD-RAM
Recordable time (DVD)	DVD (4.7GB): Approx. 1 hour (XP mode), 2 hours (SP mode), 4 hours (LP mode), 6 hours (EP mode) DVD+R DL (8.5GB): Approx. 1 hour 50 minutes (XP mode), 3 hours 40 minutes (SP mode), 7 hours 10 minutes (LP mode), 10 hours 30 minutes (EP mode)
Recordable time (HDD)	DV-DS251E HDD (250GB): Approx. 66 hours (XP mode), 129 hours (SP mode), 239 hours (LP mode), 356 hours (EP mode) DV-DS161E/ E(UK) HDD (160GB): Approx. 48 hours (XP mode), 84 hours (SP mode), 156 hours (LP mode), 233 hours (EP mode) DV-DS81E/ E(UK) HDD (80GB): Approx. 21 hours (XP mode), 41 hours (SP mode), 77 hours (LP mode), 114 hours (EP mode)

Video recording format

Sampling frequency	27MHz
Compression format	MPEG 2 (VBR support)

Audio recording format

Sampling frequency	48kHz
Compression format	Dolby Digital

Playback

Frequency response	DVD (PCM 48 kHz): 8 Hz to 20 kHz, CD: 8 Hz to 20 kHz DVD (PCM 96 kHz): 8 Hz to 44 kHz
Signal-to-noise ratio	More than 100 dB (AUDIO OUT connector)
Harmonic distortion	Less than 0.008% (AUDIO OUT connector)
Dynamic range	More than 95 dB (AUDIO OUT connector)

Inputs

AERIAL IN	Aerial input, 75 ohms
VIDEO IN	1.0 Vp-p 75 ohms, sync negative, RCA jack x 2 / SCART x 2
AUDIO IN	0 dBm more than 47 kohms, RCA jack (L, R) x 2 / SCART x 2
DV IN	4 pin (IEEE 1394 standard)



Outputs

VIDEO OUT	1 Vp-p 75 Ω, sync negative, RCA jack x 1 / SCART x 2
COMPONENT VIDEO OUT	(Y) 1.0 V (p-p), 75 Ω, negative sync, RCA jack x 1 (Pb)/(Pr) 0.7 V (p-p), 75 Ω, RCA jack x 2
HDMI video/audio output	19 pin (HDMI standard, Type A) (DV-DS251E/161E only)
Audio output (digital audio)	0.5 V (p-p), 75 Ω, RCA jack x 1
Audio output (optical audio)	3 V (p-p), 75 Ω, Optical connector x 1
Audio output (analog audio)	2.0 Vrms (1 KHz, 0 dB), 600 Ω, RCA jack (L, R) x 1 / SCART x 2

- Design and specifications are subject to change without notice.

2-3 Major Differences from Previous Model

← : Same as on left

Item	DV-DS251E/DS161E/DS81E	DV-RX7000E
Appearance		
Dimensions	432(W) x 371.5(D) x 60.5(H)mm	430(W) x 279(D) x 69(H)mm
Power consumption	Approx. 35 W	←
CPRM	Yes	←
Recordable media	DVD-RAM	←
	DVD-RW	←
	DVD-R	←
	DVD+RW	---
	DVD+R	---
	DVD+R DL	---
Playable media	DVD-RAM	←
	DVD-RW	←
	DVD-R	←
	DVD+RW	---
	DVD+R	---
	DVD+R DL	---
	DVD-VIDEO	←
	Video CD (VCD)	←
	Audio CD (CD-DA)	←
	CD-R/CD-RW (CD-DA, DivX, MP3, WMA, JPEG formatted discs)	CD-R/CD-RW (CD-DA, MP3, JPEG formatted discs)
	HDD unit	250GB: DV-DS251E
	160GB: DV-DS161E/E(UK)	---
	80GB: DV-DS81E/E(UK)	---
Remote control	DV-RM251E: For E DV-RM251E(UK) : For UK	DV-RM7000E
Memory card slot 1 (CF/MD)	Yes (DV-DS251E, 161E/E(UK) only)	---
Memory card slot 1 (SD/MMC/SMC/xD)	Yes (DV-DS251E, 161E/E(UK) only)	←
DV input terminal	1 (IEEE 1394)	
S-VIDEO input terminal	1 (Mini DIN 4pin)	2 (Mini DIN 4pin: 2)
VIDEO/AUDIO input terminals	4 (RCA: 2, SCART: 2)	4 (RCA: 2, SCART: 2)
COMPONENT VIDEO output terminal	1 (RCA)	---
S-VIDEO output terminal	---	1 (Mini DIN 4pin)
VIDEO output terminal	3 (RCA: 1, SCART: 2)	3 (RCA: 1, SCART: 2)
Analog AUDIO output terminals	3 (RCA: 1, SCART: 2)	4 (RCA: 2, SCART: 2)
Digital AUDIO output terminals	2 (Optical: 1, Coaxial: 1)	←
HDMI terminal	1 (DV-DS251E, 161E only)	---
Video output switch	Yes (COMPONENT-RGB)	Yes (SETUP screen)

2-4 Function Differences from Previous Model

← : Same as on left

	Item	DV-DS251E/DS161E/DS81E	DV-RX7000E
Recording	Time Shift	Yes[HDD]	Yes (Time Slip) [DVD·RAM]
	Clip Recording	Yes	No
	Instant Timer Recording	Yes	One Touch Recording (OTR)
	Timer Recording	Yes	←
	Recording Mode	XP, SP, LP, EP, FR	XP, SP, LP, EP, FR
	Recording from DV Input	Yes	←
Dubbing	Dubbing (HDD to DVD)	Yes	No
	Dubbing (DVD to HDD)	Yes	No
	One Touch Copy (HDD to DVD)	Yes	No
Title List	Adding Chapter Markers	Yes	←
	Changing Title Thumbnails	Yes	←
	Making a New Playlist	Yes	←
	Adding Title/Chapters	Yes	←
	Deleting Title/Chapter	Yes	←
	Deleting a Part	Yes	←
	Time Search	Yes	←
	Sort	Yes	No
	Combining Titles	Yes	No
	Divide	Yes	No
	Combining Chapters	Yes	No
	Moving a Playlist Chapter	Yes	←
	Hide a Chapter/Title	Yes	No
	Protect a Title	Yes	Yes
	Playback	Displaying Disc Information	Yes
Commercial Advance (CM Skip)		Yes	No
Random		Yes	←
Repeat A·B		Yes	←
Time Search		Yes	←
Zoom		Yes	←
Marker Search		Yes	←
Manual Skip		Yes (15 sec)	Yes (15, 30, 60 sec)
DivX Movie File Playback		Yes	No
Audio CD Playback		Yes	Yes
MP3 Playback		Yes	Yes
WMA file Playback		Yes	No
JPEG File Viewing		Yes	←
P in P		No	Yes

Remote Control

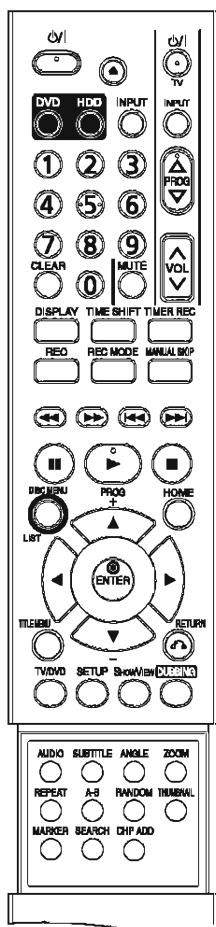

0-9 numerical buttons:

Selects numbered options in a menu.

◀ / ▶ / ▲ / ▼ (left/right/up/down): Selects an option in the menu.

▲ / ▼ (up/down): Scans up or down through memorized channels.

A-B: Repeat sequence.

ANGLE: Selects a DVD camera angle, if available.

AUDIO: Selects an audio language (DVD) or TV audio channel (CD).

CHP ADD:

Inserts a chapter marker when playing/recording.

CLEAR: Removes a track number on the Program List or a mark on the Marker Search menu.

DISC MENU/LIST:

Accesses menu on a DVD disc. Switches between Title List-Original and Title List-Playlist menu.

DISPLAY:

Accesses On-Screen Display.

DUBBING: Copies DVD to HDD (or HDD to DVD).

DVD: Select the Recorder's function mode to DVD.

ENTER

- Acknowledges menu selection.
- Displays information while viewing a TV program.

HDD: Select the Recorder's function mode to HDD.

HOME: Accesses or removes the HOME menu.

INPUT: Changes the input to use for recording (Tuner, AV1-4 or DV IN).

MANUAL SKIP:

Pressing this button during playback will skip to a scene 15 seconds forward.

MARKER: Marks any point during playback.

▲ (OPEN/CLOSE):

Opens and closes the disc tray. Operate this button only after turning the recorder on.

|| (PAUSE/STEP):

Pause playback or recording temporarily, press again to exit pause mode.

▶ (PLAY):

Starts play-back.

⏻ / ⏿ POWER:

Switches the recorder ON or OFF.

RANDOM:

Plays tracks in random order.

● (REC):

Starts recording. Press repeatedly to set the recording time.

REC MODE: Selects the recording mode (XP, SP, LP or EP).

REPEAT:

Repeat chapter, track, title, all.

RETURN (↶)

- Removes the menu.
- Display the menu of a video CD with PBC.

◀ / ▶ (SCAN):

Search backward or forward.

SEARCH:

Displays Marker Search menu.

SETUP: Accesses or removes the Setup menu.

SHOWVIEW : To display the program menu for SHOWVIEW System programming.

VIDEO Plus+ : (For UK)

To display the program menu for VIDEO Plus+ System programming.

◀◀ / ▶▶ (SKIP):

Go to next chapter or track. Returns to beginning of current chapter or track or go to previous chapter or track.

■ (STOP):

Stops playback or recording.

SUBTITLE:

Selects a subtitle language.

THUMBNAIL: Selects a thumbnail picture for the current title and chapter for use in the Original and Playlist menu.

TIMER REC:

Displays Timer Record menu.

TIMESHIFT: Activates pause live TV/playback (timeshift) for a live TV program.

TITLE MENU:

Displays the disc's Title menu, if available.

TV/DVD: To view channels selected by the recorder tuner or by the TV tuner.

TV Control Buttons

- POWER: Turns the TV on or off.
- INPUT: Selects the TV's source.
- PROG +/-: Selects TV's channel.
- VOL +/-: Adjusts TV's volume.
- MUTE: Temporarily turns TV sound OFF, press again to restore.

ZOOM:

Enlarges DVD video image.

Rear Panel

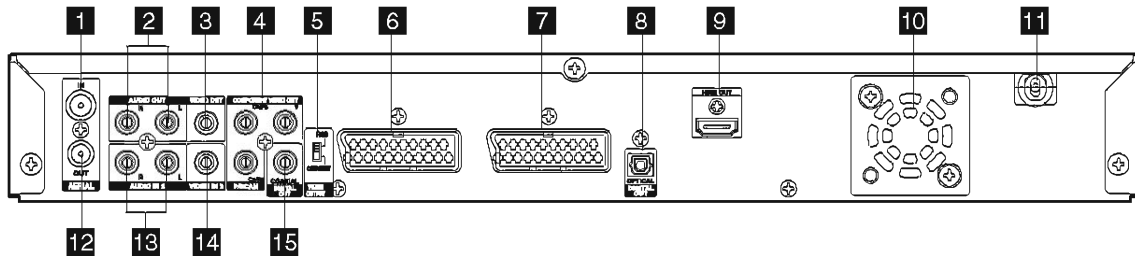

1 AERIAL

Connect the aerial to this terminal.

2 AUDIO OUT (Left/Right)

Connect to a TV with audio inputs.

3 VIDEO OUT

Connect to a TV with video inputs.

4 COMPONENT VIDEO OUT/PROGRESSIVE SCAN (Y Pb Pr)

Connect to a TV with Y Pb Pr inputs.

5 VIDEO OUTPUT Switch

Select either COMPONENT VIDEO OUT or RGB signal of EURO AV1 AUDIO/VIDEO terminal depending on how you connect the recorder to the TV.

6 EURO AV 1 AUDIO/VIDEO

Connect to a TV with SCART jack.

7 EURO AV 2 DECODER

Connect the audio/video output of an external source (Pay-TV decoder, Set Top Box, VCR, etc.).

8 OPTICAL (Digital audio out jack)

Connect to digital (optical) audio equipment.

**9 HDMI Connector (Type A)
(DV-DS251E/161E only)**

HDMI output providing a high quality interface for digital audio and video.

10 Cooling fan

11 AC Power Cord

Plug into the power source.

12 RF. OUT

Passes the signal from the AERIAL to your TV/monitor

13 AUDIO IN 3 (Left/Right)

Connect the audio output of an external source (Audio system, TV/Monitor, VCR, Camcorder).

14 VIDEO IN 3

Connect the video output of an external source (Audio system, TV/Monitor, VCR, Camcorder).

15 COAXIAL (Digital audio out jack)

Connect to digital (coaxial) audio equipment.

2-6 HDMI Connection (DV-DS251E/DS161E only)

If you have a HDMI TV or monitor, you can connect it to this recorder using a HDMI cable.

Be sure to use an HDMI cable with HDMI logo (**HDMI**).

1. Connect the HDMI jack on the recorder to the HDMI jack on a HDMI compatible TV or monitor (H).
2. Set the TV's source to HDMI (refer to TV's Owner's manual).

Notes:

- When you use the HDMI connection, the audio's sampling frequency is outputted only with 48kHz even if you select [96kHz].
- This recorder does not perform internal (2 channel) decoding of a DTS sound track. To enjoy DTS multi channel surround, you must connect this recorder to a DTS compatible receiver via one of this recorder's digital audio outputs.
- **No sound will be outputted from HDMI cable if the [Dolby Digital] or [MPEG] option is not set to [PCM] on the Setup menu.**
- The arrow on the cable connector body should face up for correct alignment with the connector on the recorder.

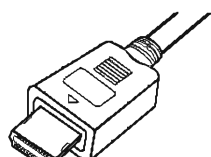

(Type A)

- If there is noise or lines on the screen, please check the HDMI cable.

Tip:

When you use HDMI connection, you can change the resolution (576i, 576p) for the HDMI output by setting the [Progressive Scan] option in the setup menu.

- Progressive Scan ON mode: 576p
- Progressive Scan OFF mode: 576i
- The recorder does not support 720p and 1080i resolutions for HDMI.

Caution

Changing the Progressive Scan mode when the recorder is connected with HDMI connector may result in malfunctions. To solve the problem, turn off the recorder and then turn it on again.

Information on HDMI

Some TVs with HDMI interface do not support "Progressive Scan OFF mode: 576i". If no image appears when the HDMI connectors on recorder and TV are joined, connect the analog VIDEO OUT jack to the video input on TV, in order to display the image through the recorder. Then use the Setup menu on recorder to specify [Progressive Scan ON mode: 576p].

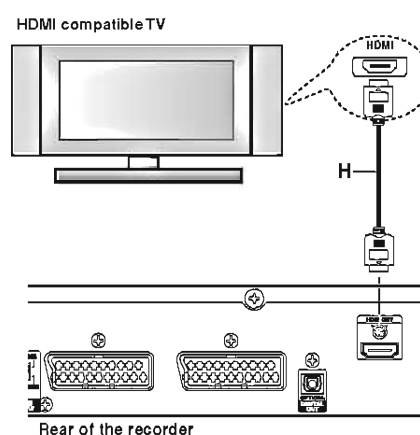

About HDMI

HDMI (High Definition Multimedia Interface) supports both video and audio on a single digital connection for use with DVD Players, Set-Top Boxes, and other AV devices.

HDMI was developed to provide the technologies of HDCP (High-bandwidth Digital Content Protection). HDCP is used to protect digital content transmitted and received.

HDMI has the capability to support standard, enhanced, or high-definition video plus standard to multi-channel surround-sound audio, HDMI features include uncompressed digital video, a bandwidth of up to 5 gigabytes per second, one connector (instead of several cables and connectors), and communication between the AV source and AV devices such as DTVs.

HDMI, the HDMI logo and High-Definition Multimedia Interface are trademarks or registered trademarks of HDMI licensing LLC.

Additional Information for HDMI

- When you connect a HDMI or DVI compatible device make sure of the followings:
 - Try switching off the HDMI/DVI device and this recorder. Next, switch on the HDMI/DVI device and leave it for around 30 seconds, then switch on this recorder.
 - The connected device's video input is set correctly for this unit.
 - The connected device is compatible with 720(1440)x576i or 720x576 progressive video input.
- Not all HDCP-compatible DVI devices will work with this recorder.
 - It's impossible copy protected-DVD title's playback in non-HDCP devices.
- If you select the HDMI output, outputs other than digital tuner output - such as D1/D2/D3 video outputs, component video outputs, S1 video output and video output (from yellow jack) - cannot be displayed.

2-7 List of Abbreviations and Terms for DVD Recorder

Index	Abbreviation/Term	Explanation
A	AC3	See Dolby AC3.
B	Black Level	Function to correct the gradations on dark portions to make dark scenes easier to see.
C	CPRM	Content Protection for Recordable Media: Copyright protection function that is suitable for online distribution of music.
	CD-R	One type of DVD standard disc, to which writing once is possible (recordable type)
	CD-RW	One type of CD standard disc, to which writing up to 1000 times is possible
	Component video output terminals	Used for outputs of HDTV video signal format. Since signals for brightness and colors are independently handled for components signals (Y: luminance signal; PR/PB: chrominance signals), degrading of image will be reduced.
D	Decoder	A device that decodes the data coded and recorded on DVD Video and restores it to video and audio signals. This processing is referred to as decoding.
	Dynamic Range	A difference between maximum and minimum levels of audio recorded on disc: Measured in decibel (dB) units. If the dynamic range is compressed (audio DRC), the minimum signal level will increase and the maximum signal level will decrease. This will reduce the higher audio signal - such as burst sound - so that the low-level audio signal - such as human voice - can be heard more clearly.
	Dolby AC3	Audio coding format developed by Dolby Laboratories in U.S, also simply referred as AC3 format. Supports 5-channel full-range sound and one channel for sub-woofer sound playback.
	DRC	Dynamic Range Control: Adjusting the audio range of maximum and minimum levels (dynamic range) will improve audio signal when, for example, dialog is hard to hear or user is watching movies late at night.
	DTS	Digital Theater System: Sound system as for movie theaters developed by US Digital Theater Systems, Inc. The number of channels provided by DTS is the same for Dolby AC3.
	DVD	Digital Versatile Disc. A huge amount of digital data for video (movie) and audio can be recorded on this disc, whose size is the same as CD.
	DVD-Audio	One type of DVD standard disc, on which high-quality audio can be recorded
	DVD-R	One type of DVD standard disc, to which writing once is possible (recordable type)
	DVD-RAM	One type of DVD standard disc, to which writing up to 100,000 times is possible
	DVD-RW	One type of DVD standard disc, to which writing up to 1000 times is possible
	DVD-Video	One type of DVD standard disc, on which high-quality video and audio can be recorded
	DVD Video Format	Video recording/playback standard that applies to DVD-Video, DVD-R and DVD-RW
	DVD Video Recording Format	Video recording/playback standard that applies to DVD-RAM and DVD-RW: This allows versatile editing functions, differing from the DVD Video Format.
H	HDMI	High-Definition Multimedia Interface: A digital video/audio input/output interface standard, mainly applied to home electronics and AV devices. The specifications of DVI (Digital Visual Interface), the display connection technology, were compiled for AV devices. Although multiple cables for video, audio and control signals were previously necessary to connect devices, only one cable is needed with HDMI.

Index	Abbreviation/Term	Explanation
I	I/P/B	DVD recorders normally use data that is common between images, and individually record different data for each image. I-picture: Images recorded independently for the reference of commonly used data. P-picture: Images created from past I-picture or P-picture B-picture: Images created from both I and P pictures, which interact between both types Since I-picture delivers the highest image quality, selecting I-picture is recommended when adjusting image quality.
J	JPEG	Joint Photographic Expert Group: International standard format for compressing still images.
M	MPEG	Moving Picture Experts Group: Standard related to compression of digital video and audio. MPEG2 is a higher standard of MPEG and is applied to video (movie) requiring higher quality.
	MPEG Audio Layer 2	One of three audio compression standards (layers 1-3) defined by MPEG
	MP3	MPEG1 Audio Layer-3: Audio data digital compression technology.
O	Optical digital audio output	Audio is usually converted to an electrical signal and transmitted from DVD to a device such as amp: When audio is converted to a digital signal, this optical digital audio output can be transmitted on optical fiber.
P	Pan & Scan/ Letterbox	Most DVD videos are produced assuming that they will be displayed on wide TV screen (aspect ratio of 16:9): If they are displayed on TV screens with 4:3 aspect ratio, 16:9 images will not quite fit on 4:3 screens. There are two ways of displaying 16:9 images on 4:3 TV: <ul style="list-style-type: none"> · Pan & Scan: Cuts out the left and right ends of images and displays them on whole screen. · Letterbox: Reproduces 16:9 images on 4:3 screens with black bands across the top and bottom of screen.
	Playback Control (PBC)	One format to play Video CD: User can select desired screens and data while watching the displayed menu screen.
	Progressive playback function	This function converts interlaced images to non-interlaced images and displays them. It can play back 24-frame/second images included in DVD movie software, etc.
S	S-Video Output	The video signal is separated into chrominance (C) and luminance (L) signals and transmitted to TV: This delivers clearer images.
	Sampling Frequency	Sampling slices audio waves (analog signal) at a specified time interval, and digitizes the levels of the sliced waves. The slicing number per second is referred to as the sampling frequency: The higher the number, the closer the sound to the original.
W	WMA	Windows Media Audio: Codec that was developed by Microsoft Corporation in USA.
Num.	3D surround	This technology localizes sound at any position using only two front speakers, by subjecting the L and R signals to matrix operation. It uses the four transfer functions from L/R speakers located at specified positions to both ears of listener located in a specified position, taking into account the shape of head and the effect of earlobes, and the two transfer functions from any position to both ears.

3 Details of Servicing and Troubleshooting

3-1 How to Remove Disc from Faulty Recorder

3-1-1 Removing Disc without Opening Case

- 1) Open the DVD door of disc tray block by hand; paste plastic tape onto the DVD door, and pull the tape: The door will easily open.
- 2) Insert a pin (unbended clip, etc.) into the hole shown in the detailed diagram of pin insertion location in Fig. 3-1-1.
- 3) Push in the pin with reasonable force: The disc tray will come out slightly.

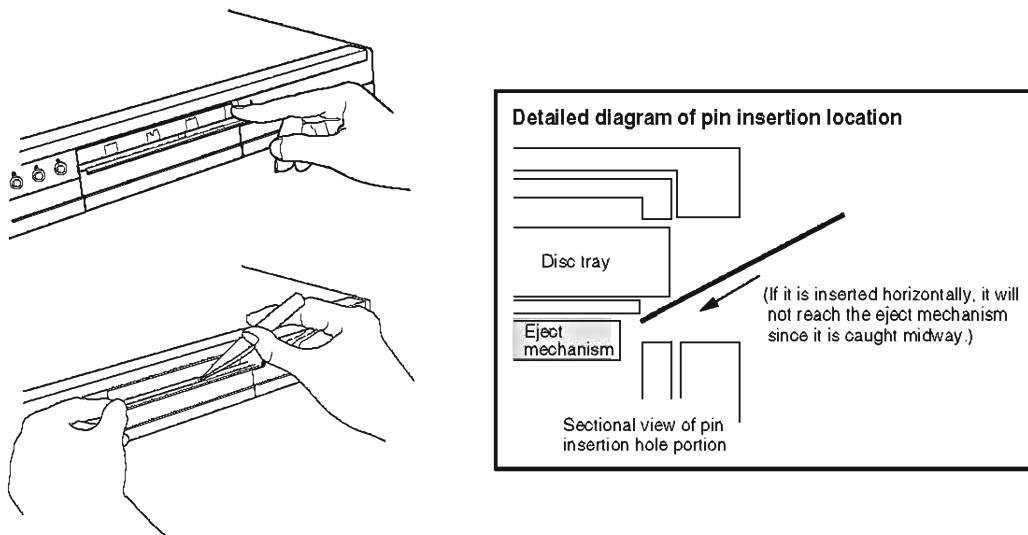

Fig. 3-1-1 Removing Disc (1)

- 4) Hold both edges of disc tray with fingers, and pull the tray out little by little to remove the disc.

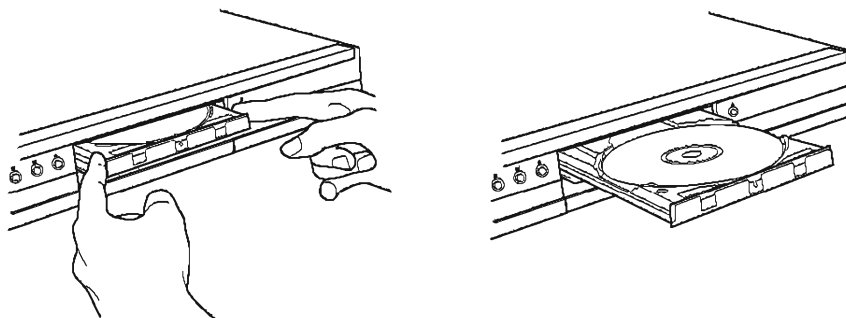

Fig. 3-1-2 Removing Disc (2)

3-1-2 Removing Disc from Faulty Recorder

If disc cannot be removed due to fault, disassemble the recorder and remove the disc by the following procedure:

- 1) Remove the top cover.
[See 4-2 (1) for removal procedure.]
- 2) Remove the front panel.
[See 4-2 (2) for removal procedure.]
- 3) Push the white component portion under the disc tray strongly, and the tray will come slightly forward.
Remove the disc tray in the direction of arrow.
Perform this work carefully, making sure that the disc is not scratched.

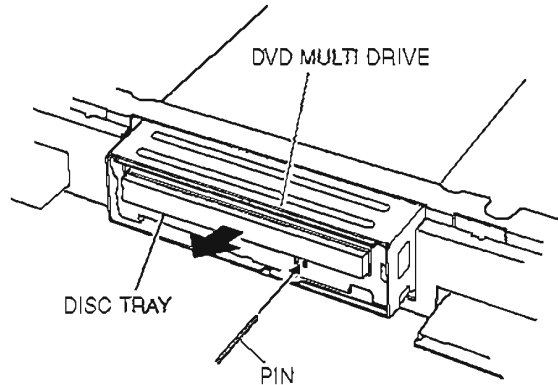

Fig. 3-1-3 Removing Disc (3)

3-2 Details of Servicing

3-2-1 Setting to defaults at the factory

Perform the following procedure to reset this HDD/DVD recorder to the initial status when it was shipped from the factory (defaults):

- 1) Press the SETUP button on remote control and use the cursor ▲▼ buttons to choose the [Initialization] menu.
- 2) Press the cursor ► button to move to the second level.
- 3) Use the cursor ▲▼ buttons to choose "Factory Set", and then press the ENTER ● button.
The confirm message will appear.
- 4) Use the cursor buttons to select [Yes], and then press the ENTER ● button.



Fig. 3-2-1

3-2-2 Troubleshooting HDD

This section shows how to determine a fault in HDD and how to format a new HDD to replace the faulty HDD.

(1) HDD troubleshooting method

If the playback picture temporarily stops or distortion occurs frequently, the HDD may be faulty. If this happens, observe the defective phenomenon, decide whether the HDD is faulty, and then repair or replace the HDD.

When replacing the HDD, note that the data on the old HDD cannot be transferred to a new HDD.

Information:

When discarding a faulty HDD, physically destroy it or perform procedure as required, according to the regulations in each country, in order to protect any personal information.

Diagnosis using HDD operation sound

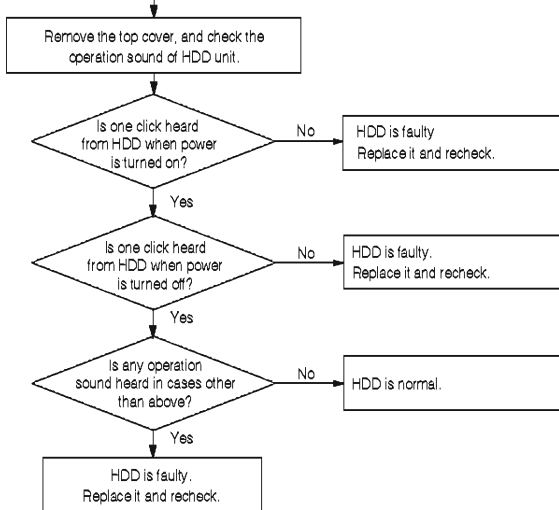

"PLEASE WAIT" does not disappear from front display.

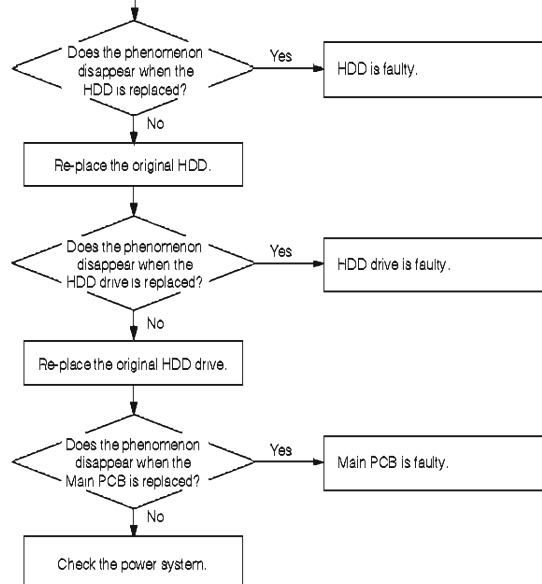

Recorder stops at the same point during HDD playback.

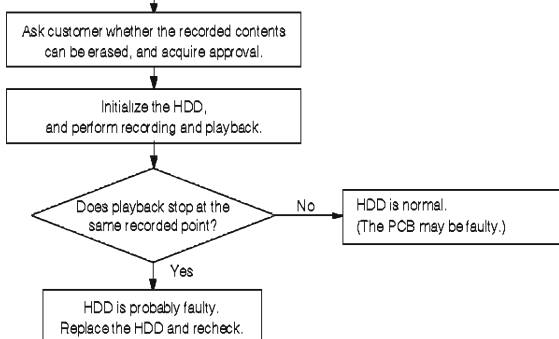

Recorder stops at the same point during HDD recording.

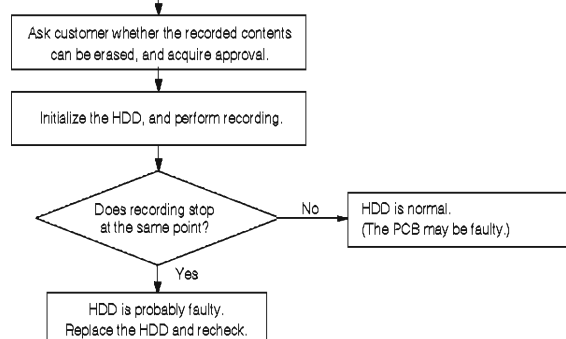

(2) Formatting HDD

After replacing the built-in HDD, use the following procedure to format the new HDD:

- 1) Press the SETUP button on remote control and use the cursor ▲▼ buttons to choose the [Initialization] menu.
- 2) Press the cursor ► button to move to the second level.
- 3) Use the cursor ▲▼ buttons to choose "HDD Format" and then press the ENTER ● button.

The confirm message will appear.

- 4) Use the cursor buttons to select [Yes] and then press the ENTER ● button.



Fig. 3-2-2

3-2-3 Firmware

The firmware is occasionally updated to improve performance.

Check whether a customer complaint can be solved by updating of firmware. If the complaint can be solved, update the firmware.

Information:

If any corrections in firm ware are made at the factory, information on how to obtain the firmware data and create a disc containing upgraded firmware will be reported in technical bulletin, etc.

(1) Version check procedure

- 1) With the HDD/DVD recorder turned on, make sure that no disc is inserted.
- 2) Connect a monitor TV to the video output terminals on this HDD/ DVD recorder.
- 3) Press the SETUP button on remote control and use the cursor ▲▼ buttons to choose the [LOCK] menu (Fig. 3·1·4).
- 4) Press numeric buttons "7" "8" "8" "9" on the remote control in sequence.
- 5) The firmware version screen will appear on the monitor TV (Fig. 3·2·3).
- 6) Turn the HDD/DVD recorder off to switch off the display.



Fig. 3-2-3

(2) Main firmware updating procedure

(2-1) To make Main firmware updating CD

- 1) Store the Main firmware data in PC.
- 2) Start a CD writer program, and drag the Main firmware data file (write it to the Root folder on CD).
- 3) Check the file name (LG_HDR_UPDATE.004). If it is incorrect, rename it.
- 4) Change the volume name of CD to RH7000_UP.
- 5) Write the Main firmware data to a CD-R or CD-RW.

(2-2) To updating the Main firmware

- 1) Turn the HDD/DVD recorder on and press the OPEN/CLOSE ▲ button.
- 2) Insert the firmware disc.
- 3) Press HOME button on the remote control to display the Home Menu screen (Fig. 3-2-4).
- 4) Select the [DISC] and press the ENTER button. Options appear.
- 5) Select the [MOVIE] and press the ENTER button: The screen for verifying update will appear (Fig. 3-2-5).
- 6) Select the [YES] and press the ENTER button: The screen for verifying update will appear (Fig. 3-2-6).
- 7) Press the REC ● button on this HDD/DVD recorder three times: Both the current version of main firmware and the version of main firmware on the disc will appear on the screen (Fig. 3-2-7).
- 8) Pressing the REC ● button on this HDD/DVD recorder will start writing (Fig. 3-2-8).
To cancel writing, press the OPEN/CLOSE ▲ button and remove the disc.
- 9) When updating is complete, the tray will open automatically: Remove the disc.
- 10) Turn the HDD/DVD recorder off and then on: The firmware is now updated.



Fig. 3-2-4



Fig. 3-2-5



Fig. 3-2-6

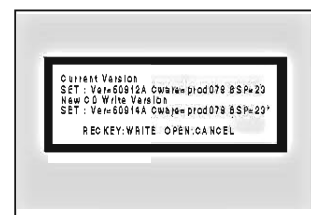

Fig. 3-2-7

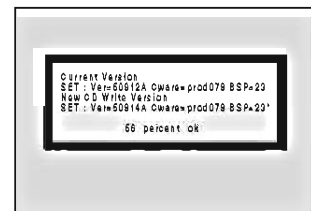

Fig. 3-2-8

(3) Loader firmware updating procedure

(3-1) To make loader firmware updating CD

- 1) Store the loader firmware data in PC and decompress it: Three files (prm, bin, bin) will appear.
- 2) Start a CD writer program and drag the three loader firmware data files (write them to the Root folder on CD).
- 3) Change the volume name of CD to DRIVE_UP.
- 4) Write the loader firmware data to a CD-R or CD-RW.

(3-2) To updating the loader firmware

- 1) Turn the HDD/DVD recorder on and press the OPEN/CLOSE ▲ button.
- 2) Insert the firmware disc: The screen for verifying update will appear (Fig. 3-2-9).
- 3) Press the REC ● button on this HDD/DVD recorder three times: The data on disc will be read, the Firmware Update screen will appear, and the loader firmware version along with the version of loader firmware on the disc, will appear on the screen (Fig. 3-2-10).
When reading the data on disc is complete, the disc tray will open automatically: Remove the disc.
- 4) Press the REC ● button on this HDD/DVD recorder.
To cancel writing, press the OPEN/CLOSE ▲ button.
- 5) Turn the HDD/DVD recorder off automatically.



Fig. 3-2-9



Fig. 3-2-10

(4) Main/Loader firmware simultaneous updating procedure

(4-1) To make firmware updating CD

- 1) Start a CD writer program, and write the Main and Loader firmware data to one CD-R or CD-RW in the "Track at once" mode.

(4-2) To update the firmware

- 1) The method of simultaneously updating the Main/Loader firmware programs is basically the same as that for updating individual programs. When the firmware disc is inserted, the screen for choosing the firmware programs to be updated will appear: Choose [All] (Fig. 3-2-11).
After the Main firmware is updated, the Loader firmware updating screen will automatically appear.

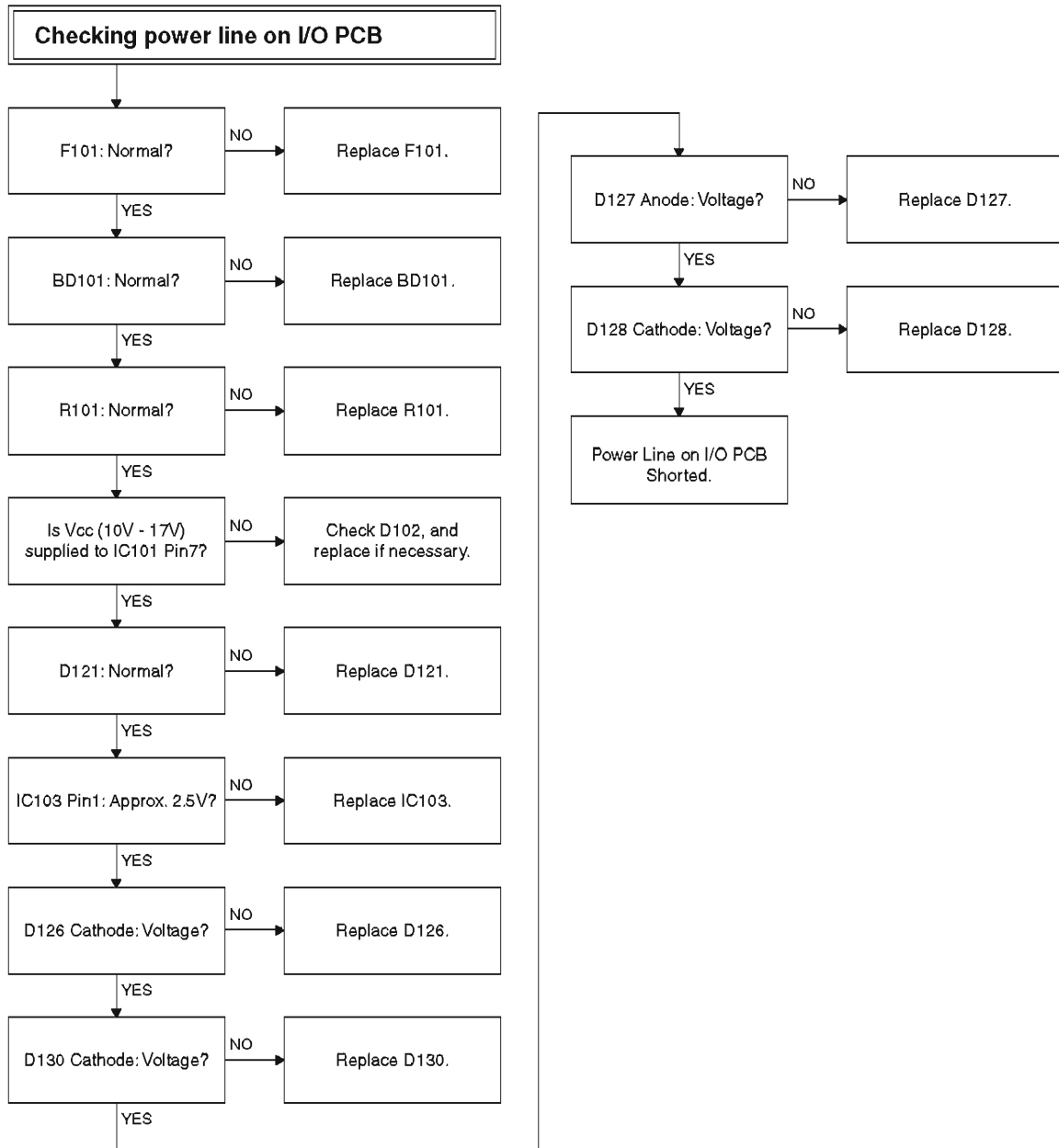

Fig. 3-2-11

3-3 Troubleshooting

3-3-1 Troubleshooting electronic system

(1) SMPS Circuit



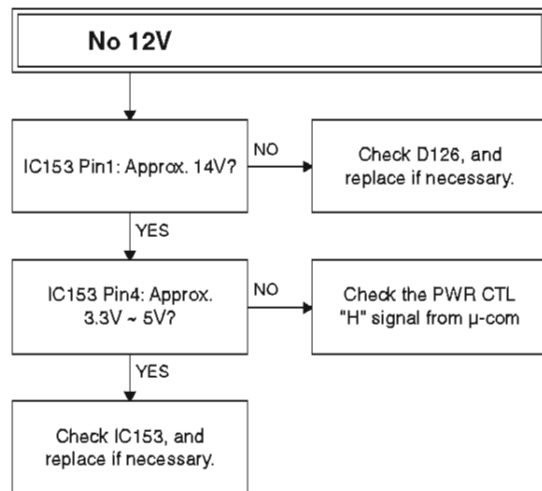
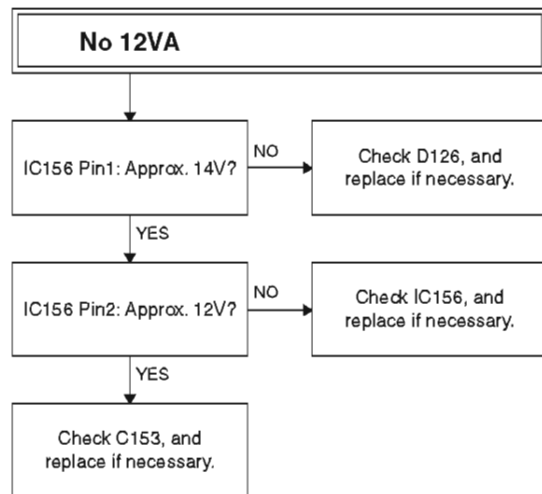
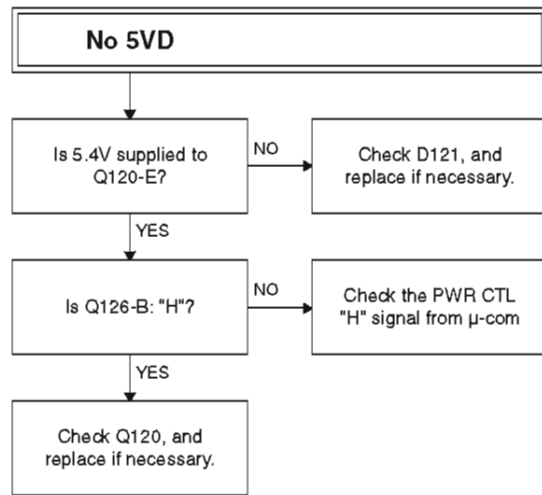
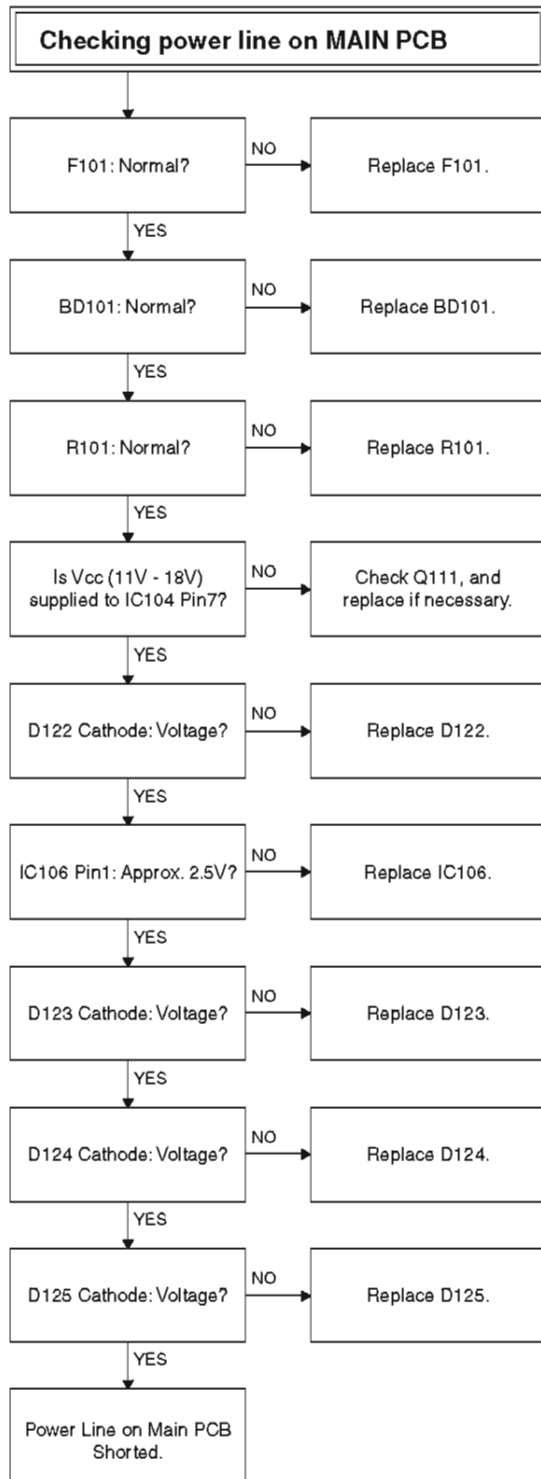

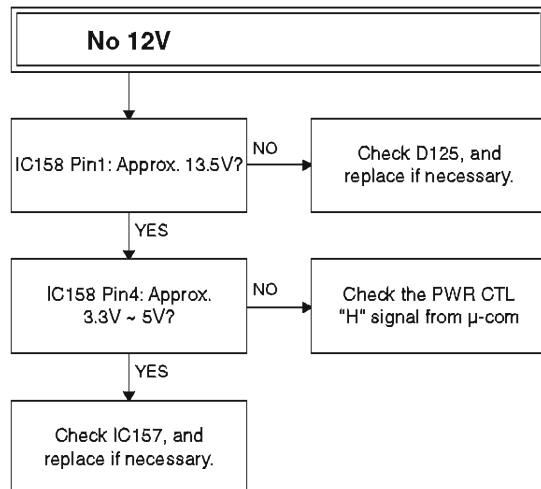
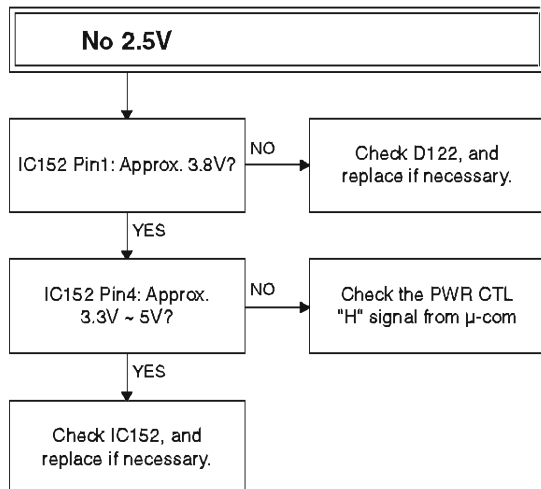
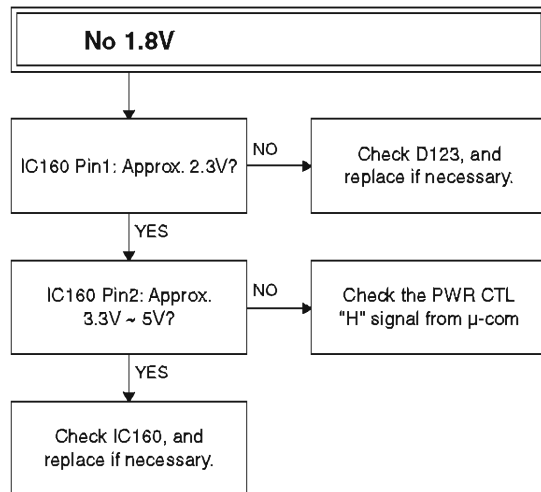
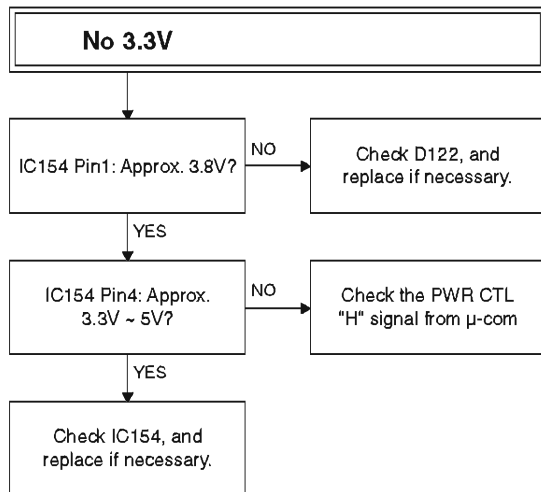
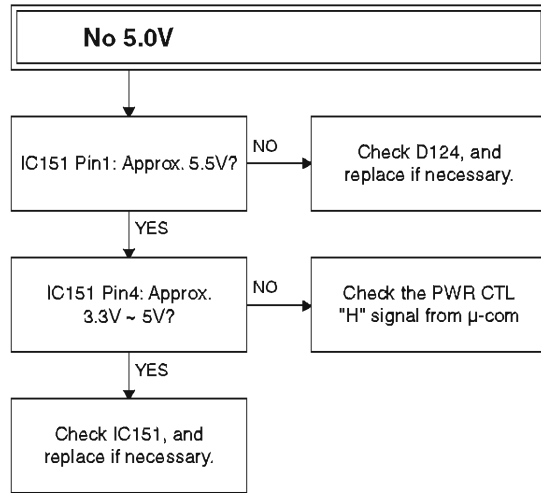
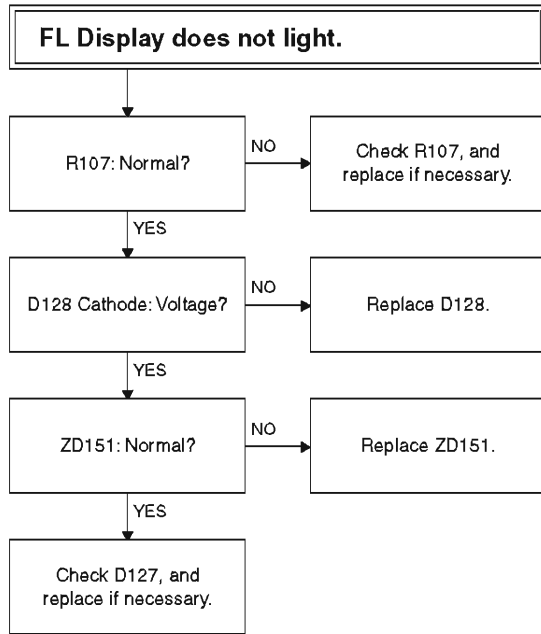

(2) SYSTEM Circuit

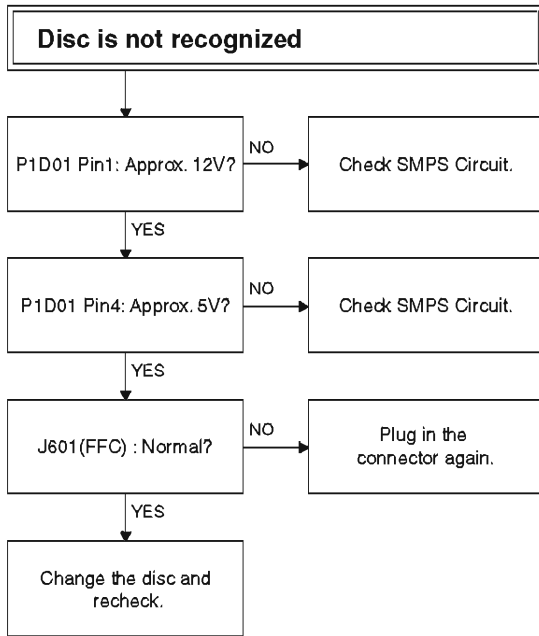

(3) AUDIO Circuit

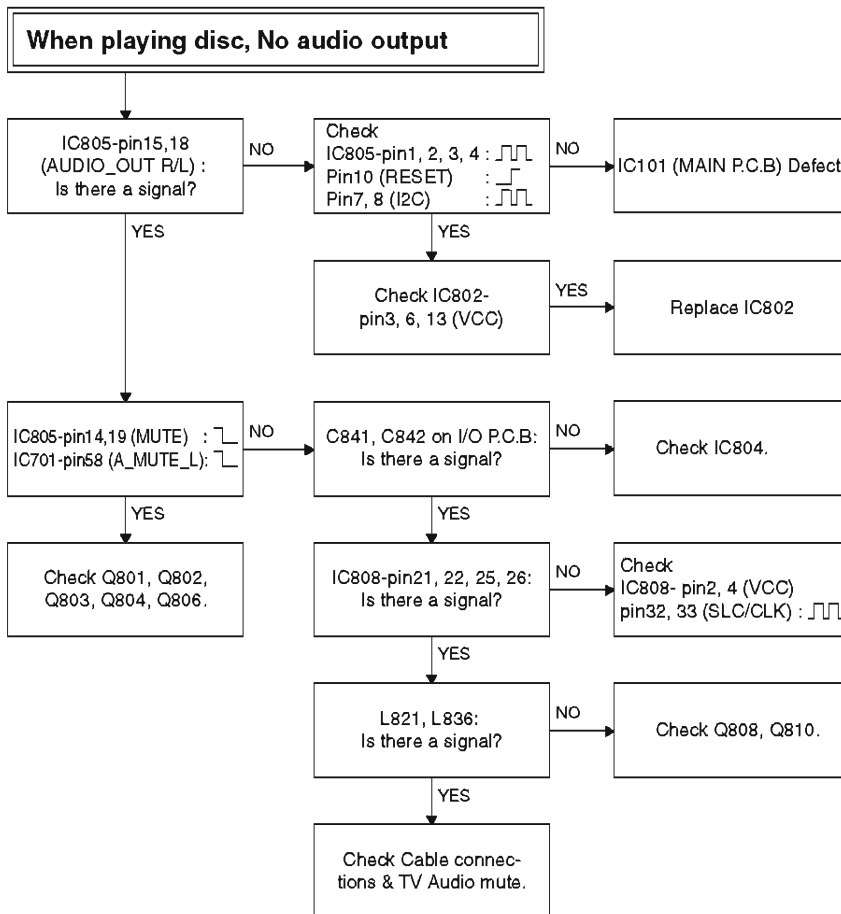

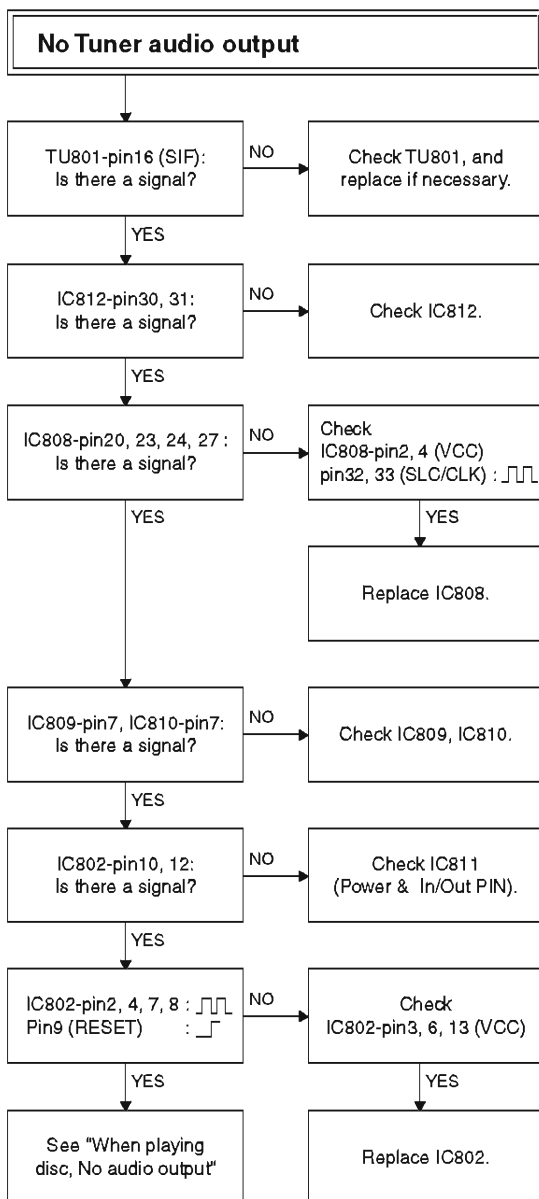
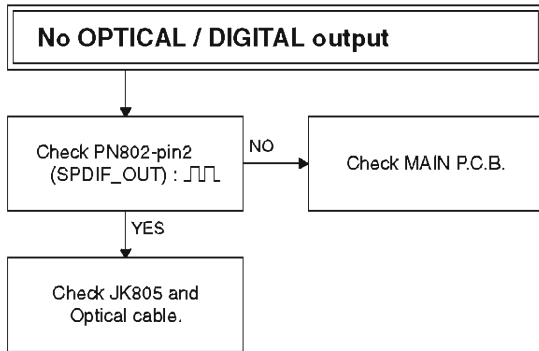

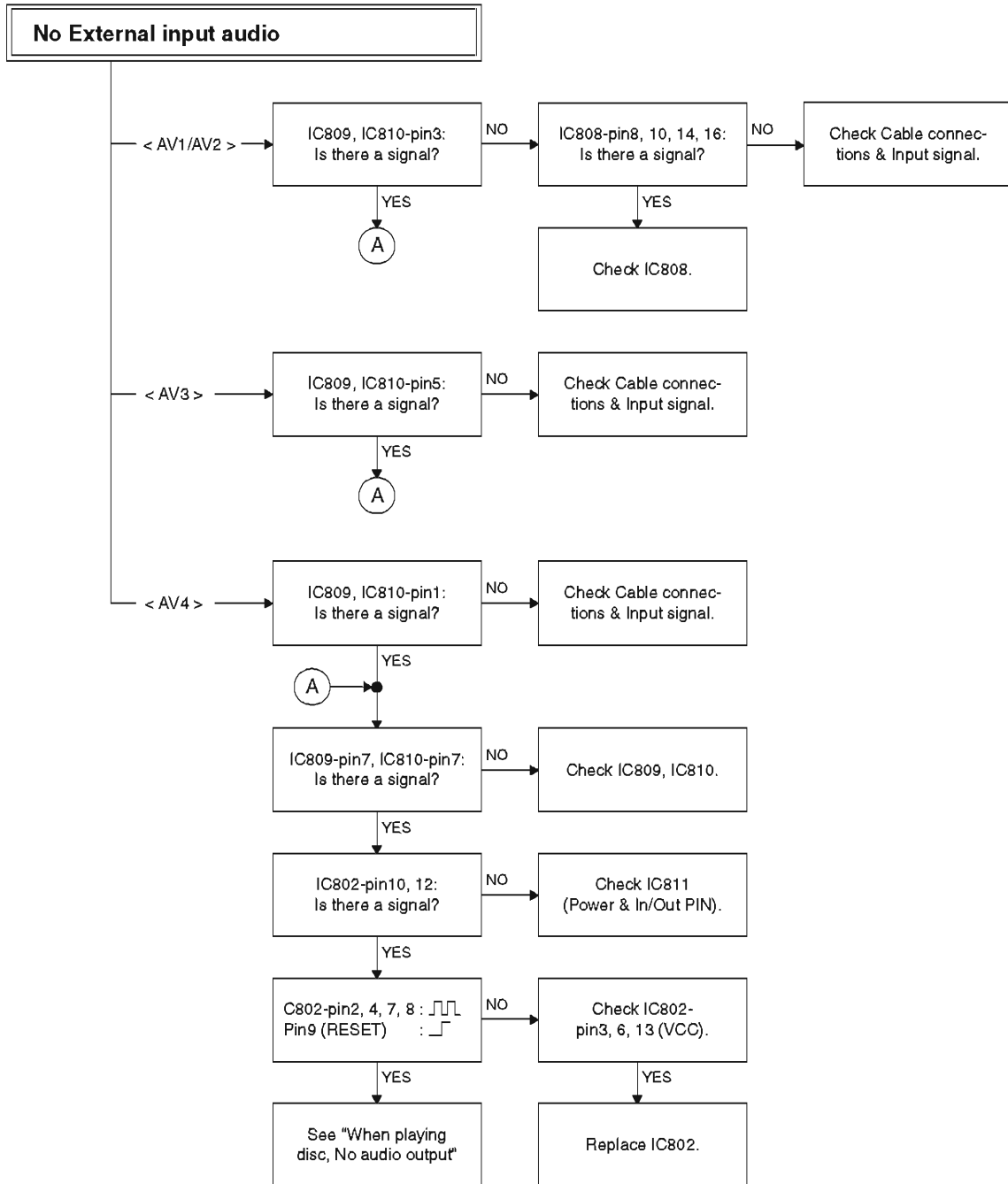

(4) VIDEO Circuit

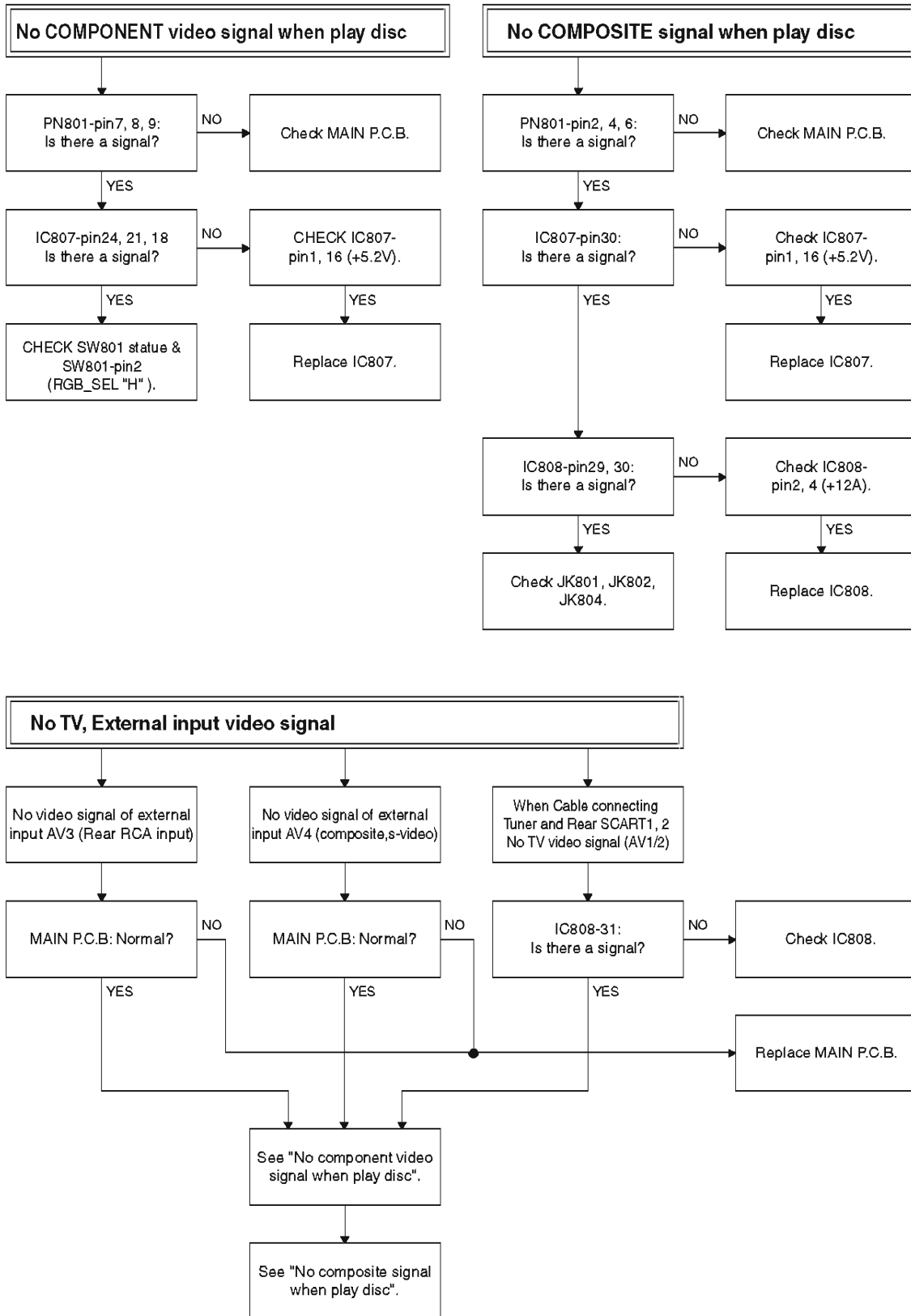

(5) COMMERCIAL ADVANCE Circuit

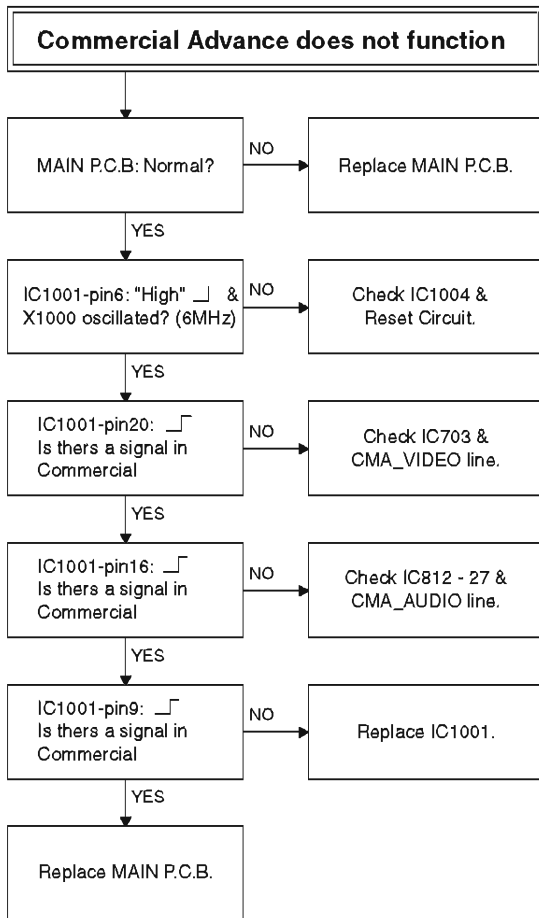

4 Disassembly and Reassembly

4-1 Order of Disassembly

Refer to the Disassembly Flowchart in Fig. 4-1-1 for the order of removing components. When reassembling components, use the reverse order to removal unless otherwise specified.

Reading Disassembly Flowchart:

After locating the target component in the flowchart, remove all components of the target in sequence, following the arrows (routes) from the top of flowchart. If multiple routes exist to the target component from the top of flowchart, remove all the components on all the routes.

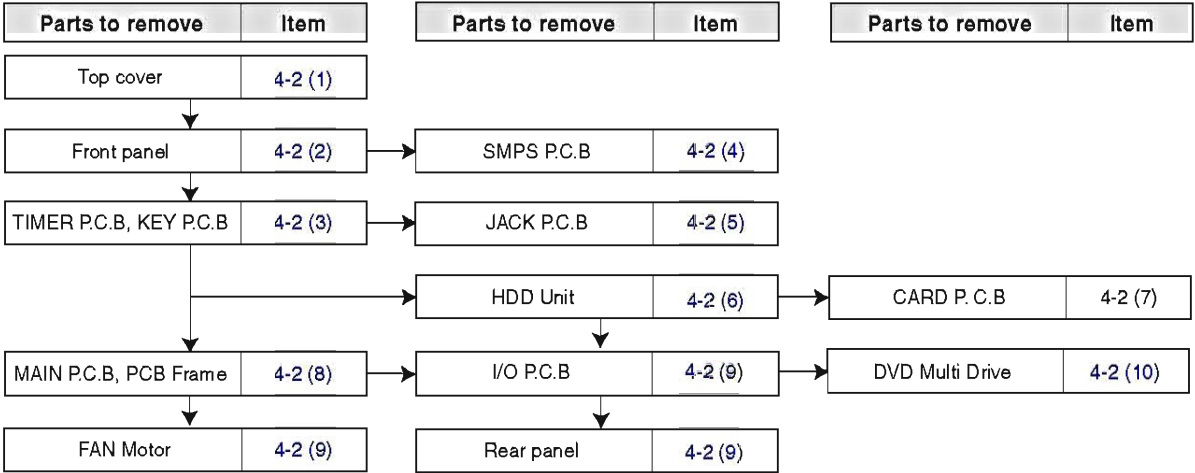

Fig. 4-1-1 Disassembly Flowchart

4-2 Disassembly

Information:
 Numbers in figures are step numbers in disassembly procedure, and letters in brackets [] show the types of screw.

(1) Top Cover

- 1) Remove the seven screws [A].
- 2) Slightly open both ends on the front side of top cover and lift the top cover in the direction of the arrow.

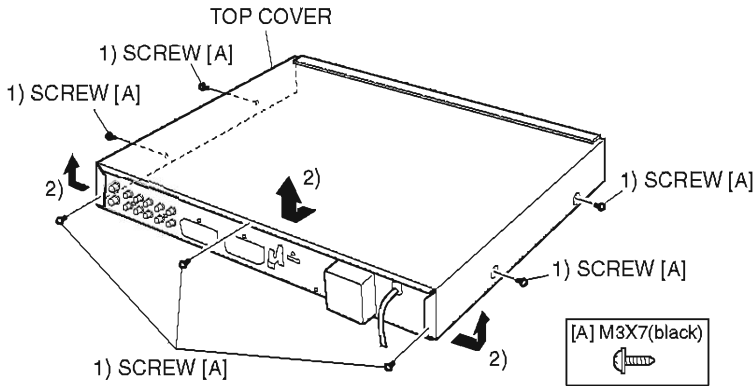

Fig. 4-2-1 Top cover

(2) Front Panel

- 1) Release four tabs (A), two tabs (B) and three tabs (C) in this order. (The tab (A) and the tab (C) should be released at the same time, respectively.)
- 2) Slowly move the front panel forward to remove it.
- 3) Remove the Timer P.C.B and Key P.C.B.

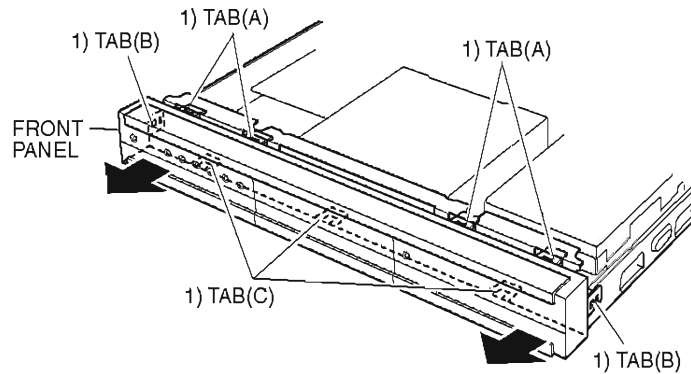

Fig. 4-2-2 Front Panel

(3) TIMER P.C.B, KEY P.C.B

■ TIMER P.C.B

- 1) Remove the two screws [B] on the P.C.B.
- 2) Release the tab.
- 3) Unplug the three connectors.

Information

During reassembly, attach the earth plates to the specified positions, making sure of correct orientation.

■ KEY P.C.B

- 4) Remove the three screws [B] on the P.C.B.
- 5) Unplug the connector.

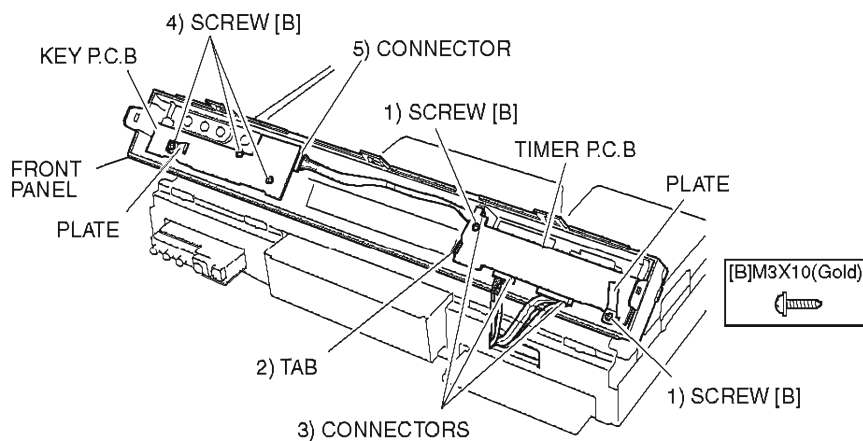

Fig. 4-2-3 TIMER P.C.B, KEY P.C.B

(4) SMPS P.C.B

- 1) Unplug the five connectors on SMPS P.C.B.
- 2) Remove the power cable from the rear panel.
- 3) Remove the four screws [C] on the P.C.B, and then lift the SMPS P.C.B.

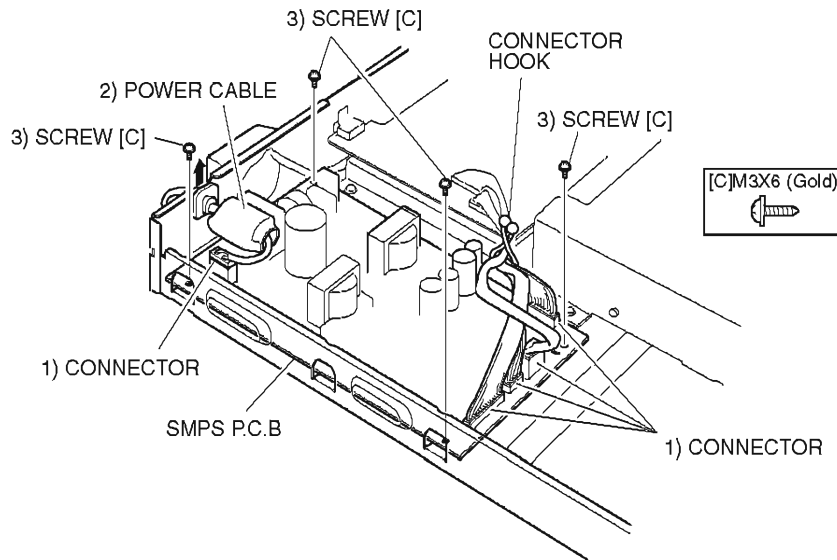

Fig. 4-2-4 SMPS P.C.B

(5) JACK P.C.B

- 1) Unplug the connector on Jack P.C.B.
- 2) Remove the three screws [C] on the Jack P.C.B, and lift the P.C.B in the direction of the arrow.

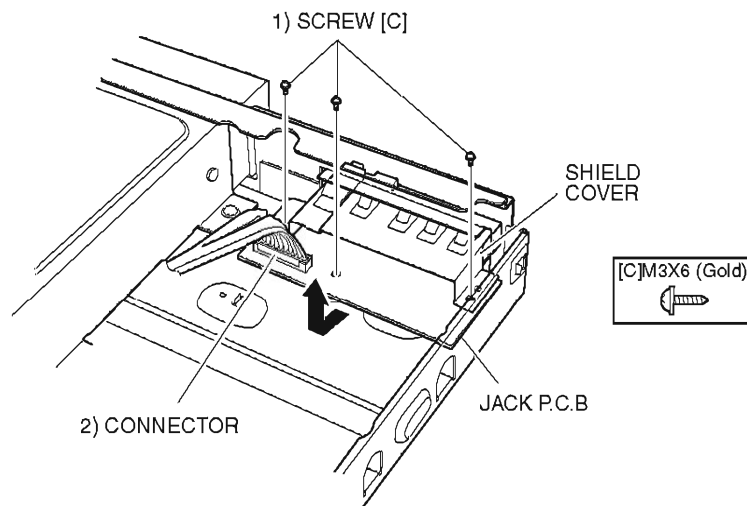

Fig. 4-2-5 JACK P.C.B

(6) HDD Unit

- 1) Disconnect the HDD connector on Main P.C.B.
- 2) Remove the four screws [C] on the HDD unit, and then lift the HDD unit.
- 3) Remove the power cable from HDD unit.
- 4) Remove the screw [C] on the HDD P.C.B.
- 5) Unplug the direct connector that connects the HDD unit and HDD P.C.B.

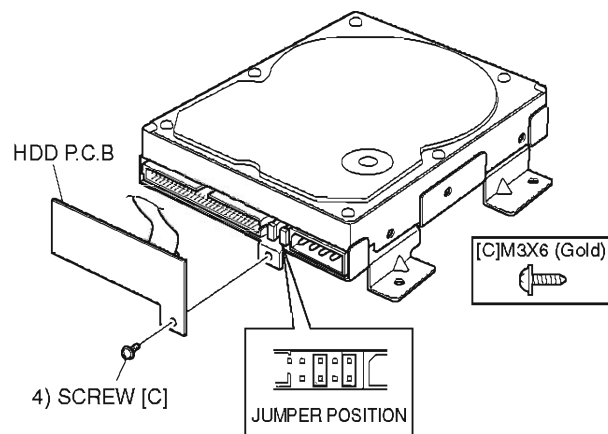
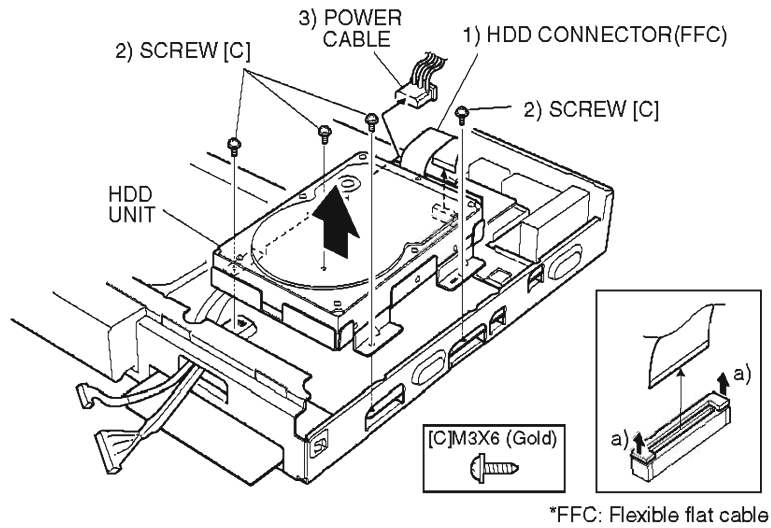

Fig. 4-2-6 HDD Unit

(7) CARD P.C.B

- 1) Disconnect the FFC on Card P.C.B.
- 2) Remove the three screws [C] on the Card P.C.B, and lift the Card P.C.B in the direction of the arrow.

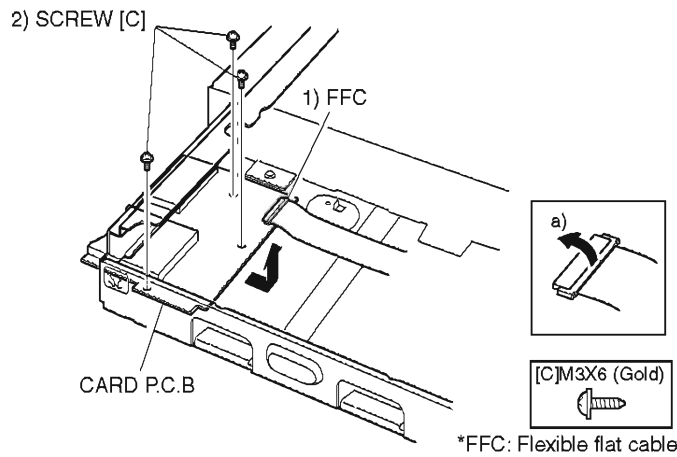

Fig. 4-2-7 CARD P.C.B

(8) MAIN P.C.B, PCB Frame

- 1) Unplug the two connectors and disconnect the two FFCs.
- 2) Remove the five screws [C] on the Main P.C.B.
- 3) Remove the screw [D] from the rear panel.
- 4) Unplugging the two direct connectors that connect the I/O P.C.B and Main P.C.B, lift the entire Main P.C.B straight up.
- 5) Remove the three screws [C] on the PCB frame.
- 6) Remove the PCB frame.

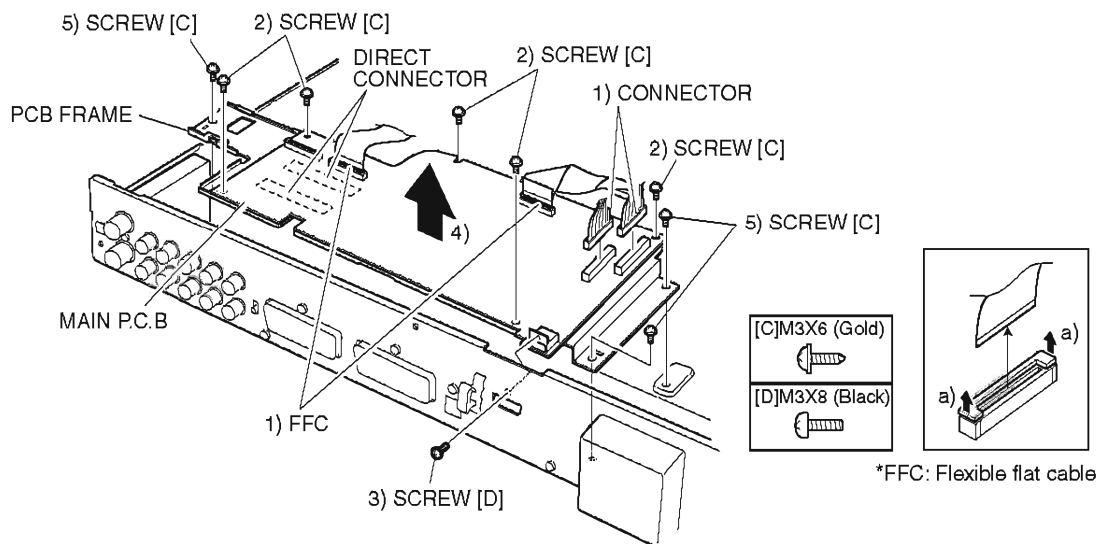

Fig. 4-2-8 MAIN P.C.B, PCB Frame

(9) I/O P.C.B, Rear Panel, FAN Motor

■ I/O P.C.B

- 1) Unplug the four connectors on the I/O P.C.B.
- 2) Remove the four screws [C] on the I/O P.C.B.
- 3) Remove the six screws [D] from the rear panel.
- 4) Move the entire I/O P.C.B in the direction of the arrow, and then remove the I/O P.C.B by releasing the jacks from the rear panel.

■ Rear Panel

- 5) Remove the power cable form rear panel.
- 6) Remove the two screws [E] from the rear panel.
- 7) Unplug the FAN motor connector on the I/O P.C.B.
- 8) Release the hooks on both sides of rear panel, and then remove the rear panel.

■ FAM Motor

- 9) Remove the two screws [F] from the FAN motor.

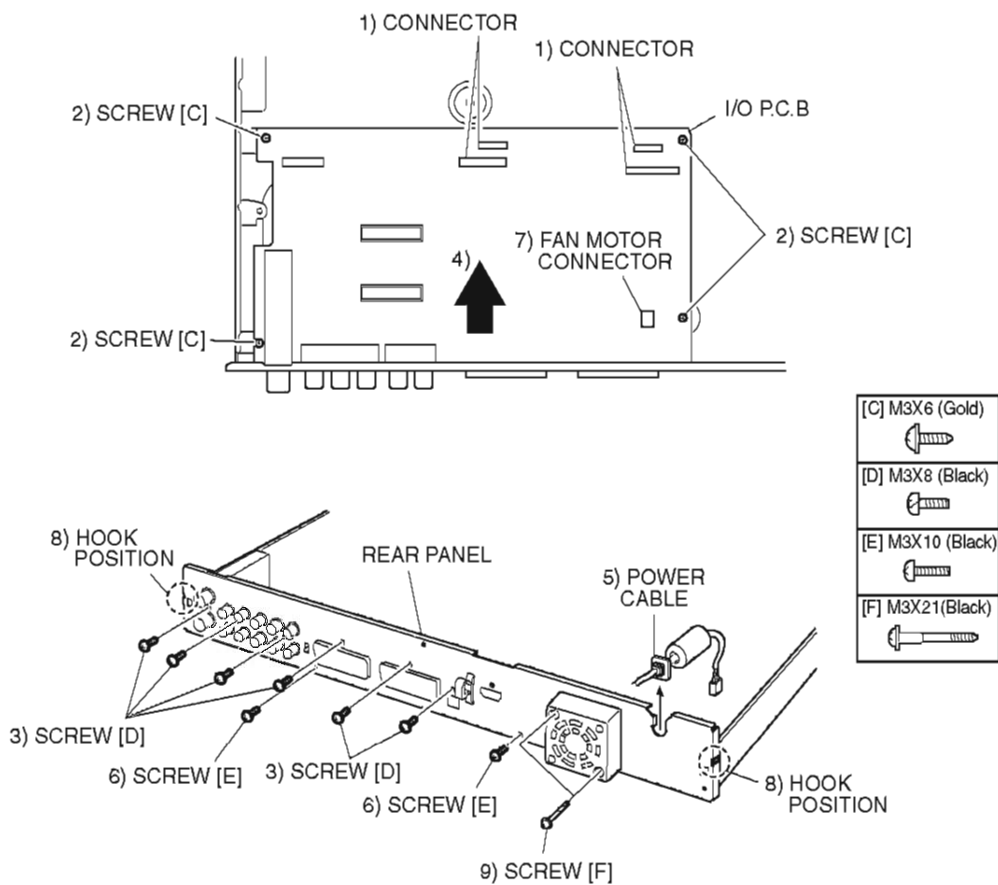

Fig. 4-2-9 I/O P.C.B, Rear Panel, FAN Motor

(10) DVD Multi Drive

- 1) Unplug the connector on SMPS P.C.B.
- 2) Remove the four screws [C] on the DVD multi drive, and lift the DVD multi drive in the direction of the arrow.
- 3) Remove the power cable form DVD multi drive.
- 4) Unplugging the direct connector that connect the DVD multi drive and Loader P.C.B.

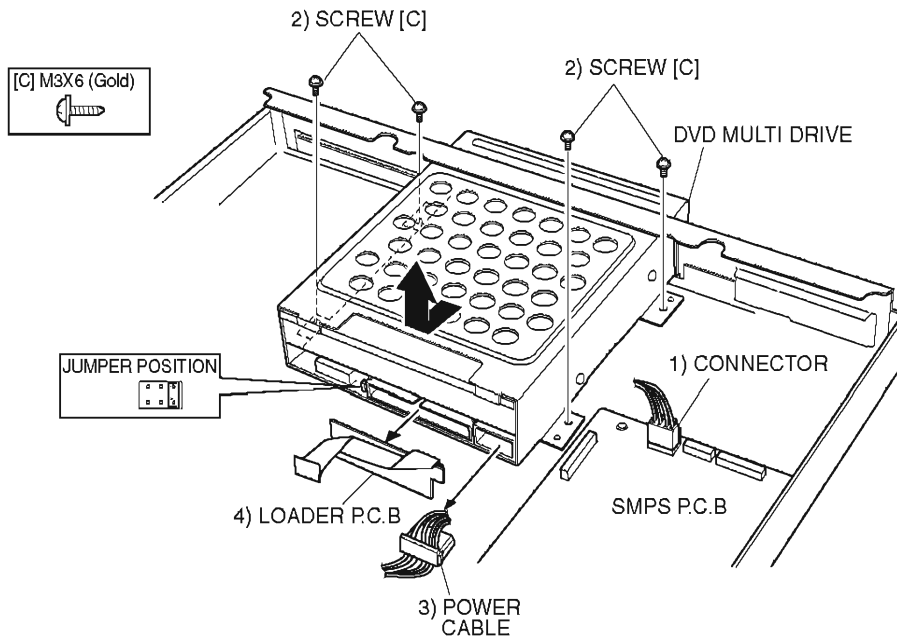
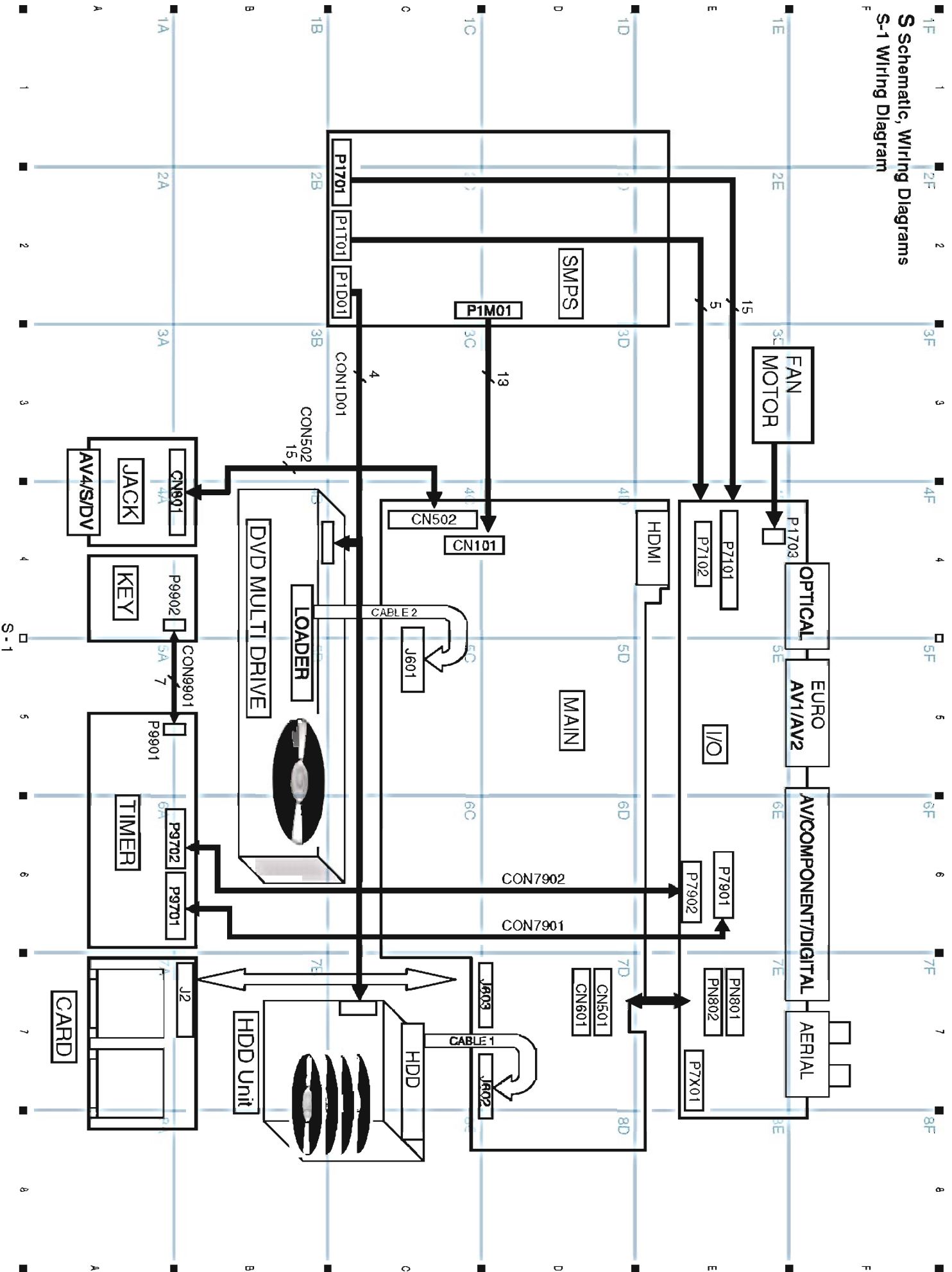

Fig. 4-2-10 DVD Multi Drive

S Schematic, Wiring Diagrams

S-1 Wiring Diagram



S-2 SMPS Schematic Diagram

TW: JUMPER

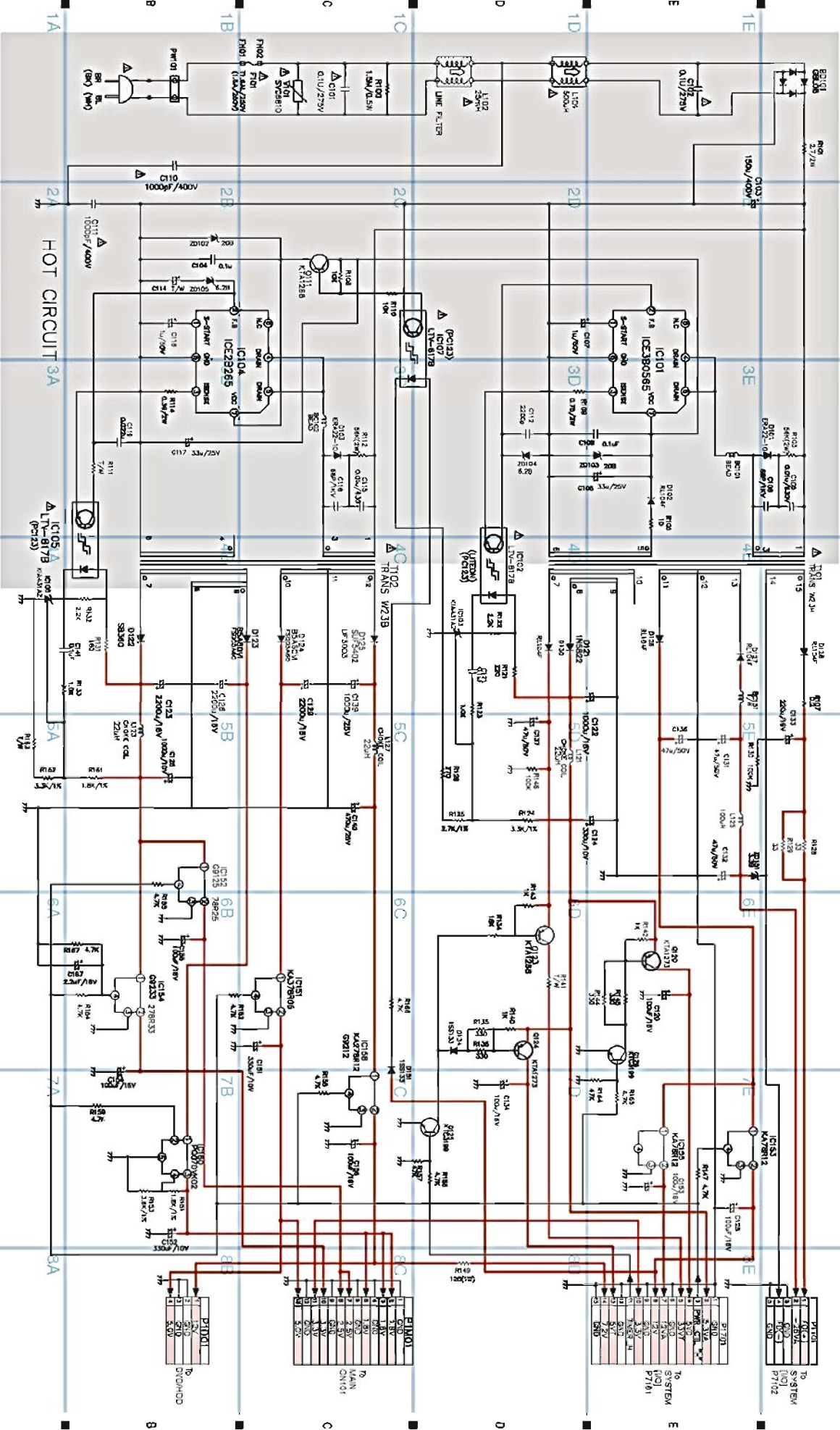

NOTE 1 Symbol denotes AC ground
TW Symbol denotes DC chassis ground

NOTE 2 Values that are shaded in red are critical when resistor or capacitor tolerance is specified

S-4 TUNER/JACK Schematic Diagram (I/O P.C.B)

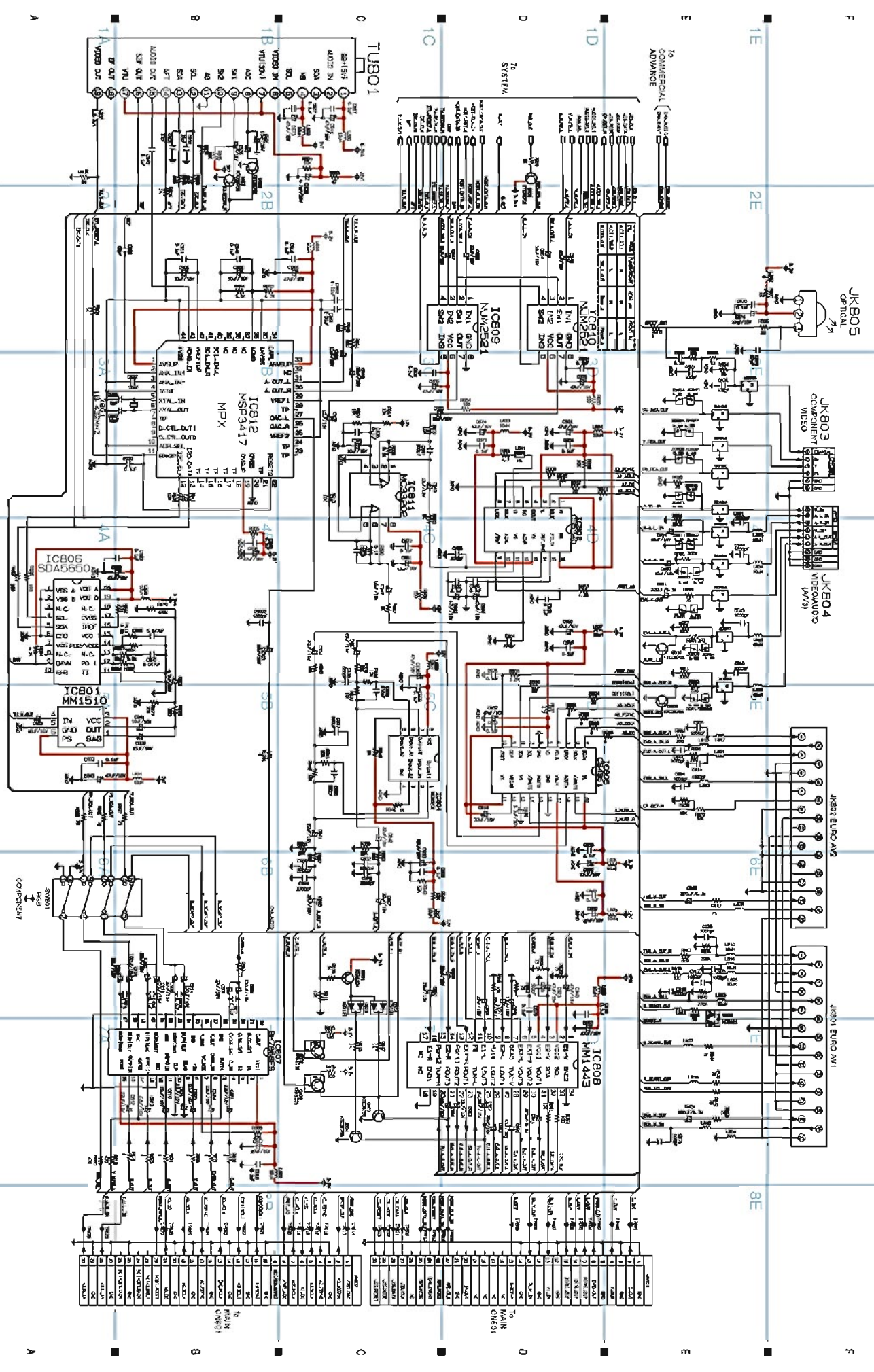

S-5 COMMERCIAL ADVANCE Schematic Diagram (I/O P.C.B.)

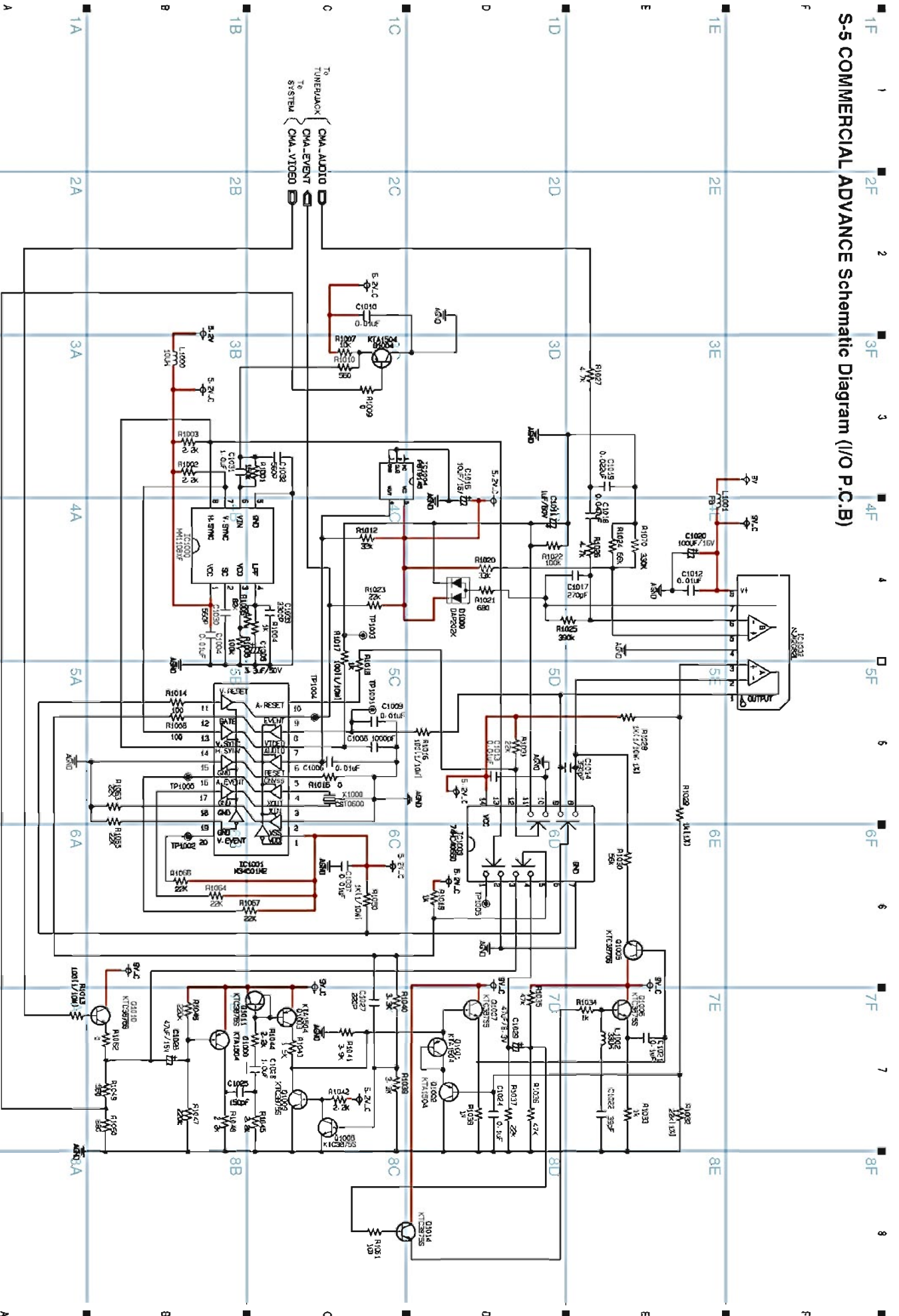

S-6 JACK Schematic Diagram

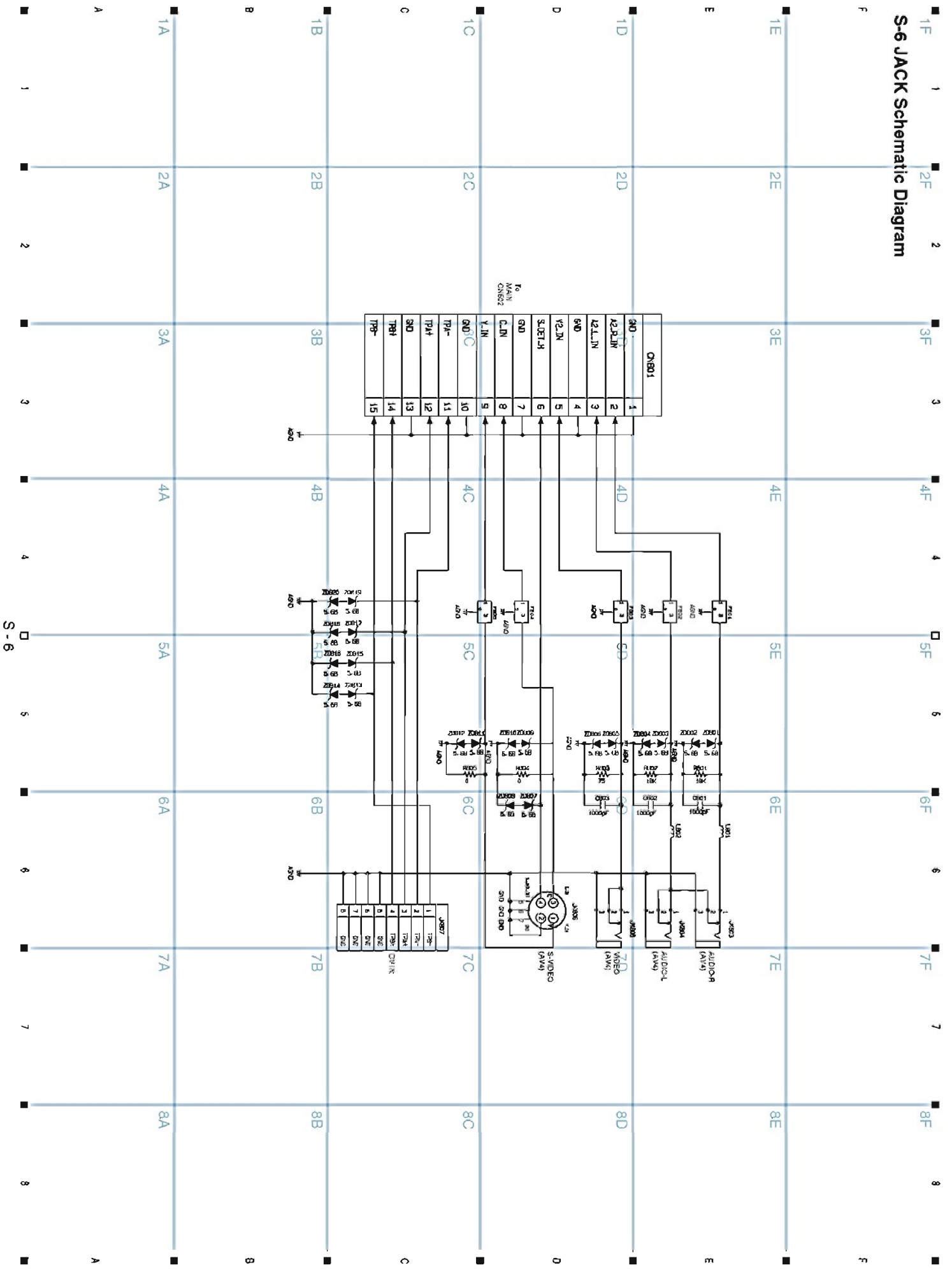

S-7 TIMER, KEY Schematic Diagrams

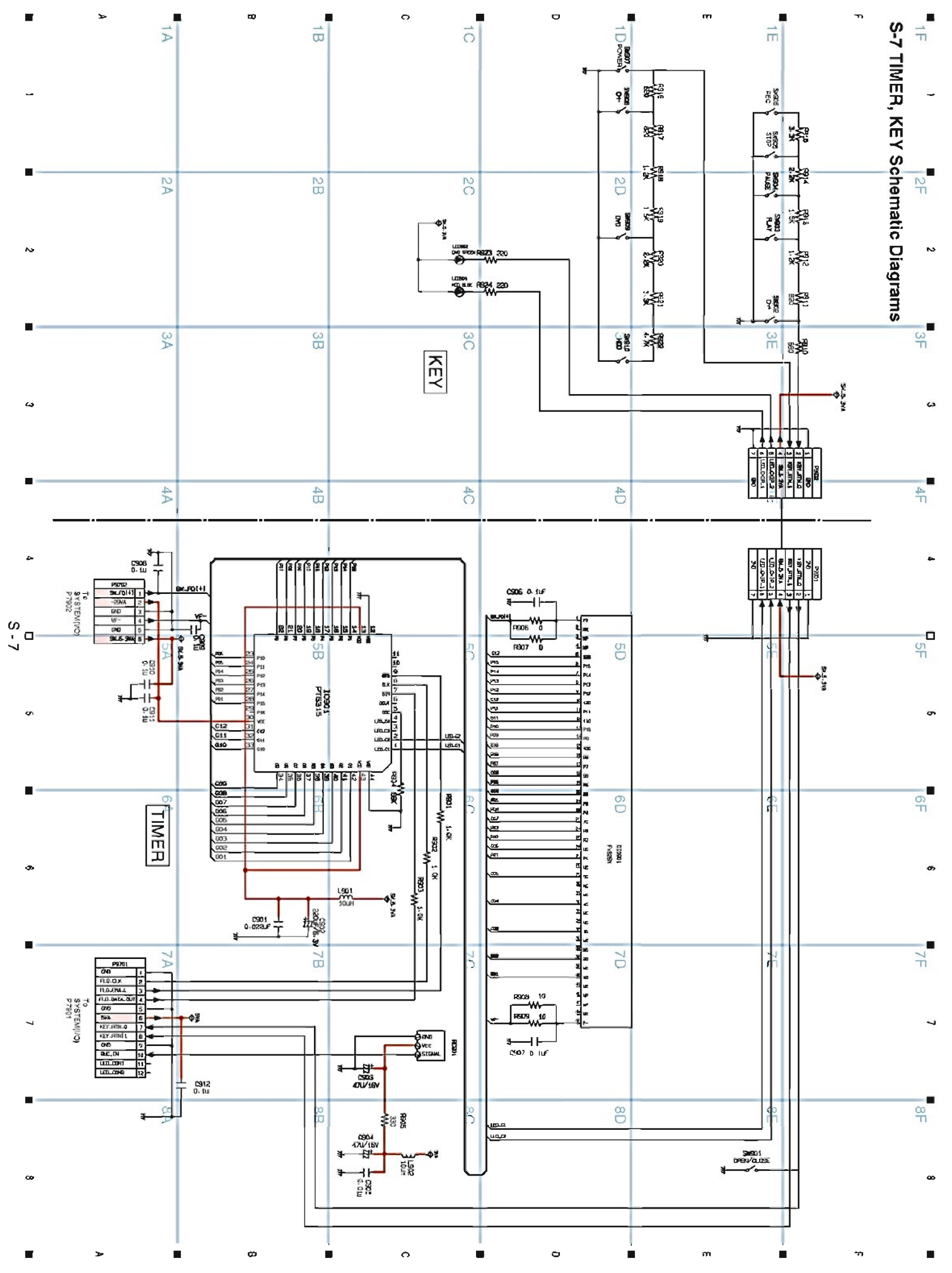

S-8 CARD-1 Schematic Diagram (CARD P.C.B)

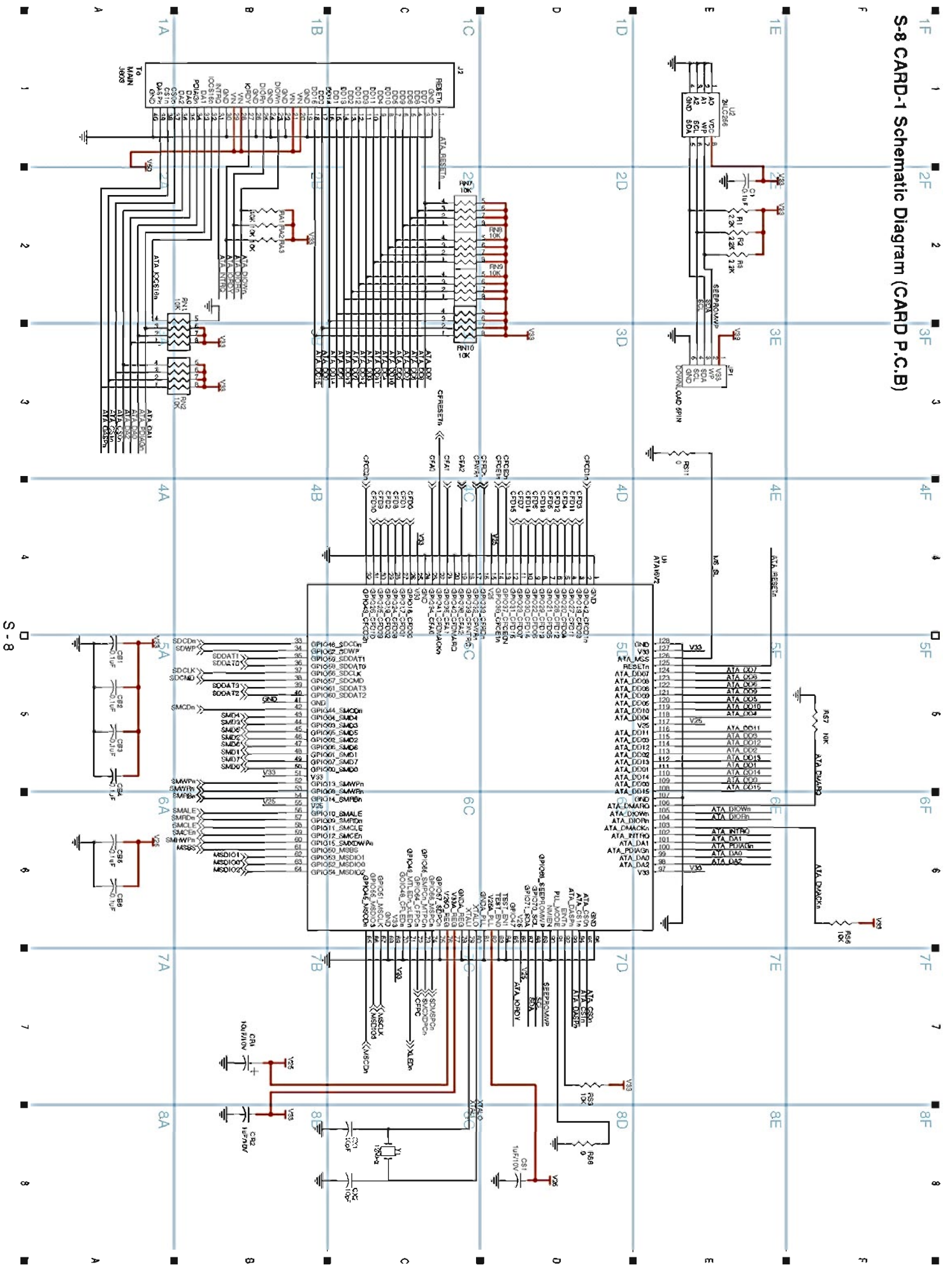

S-9 CARD-2 Schematic Diagram (CARD P.C.B)

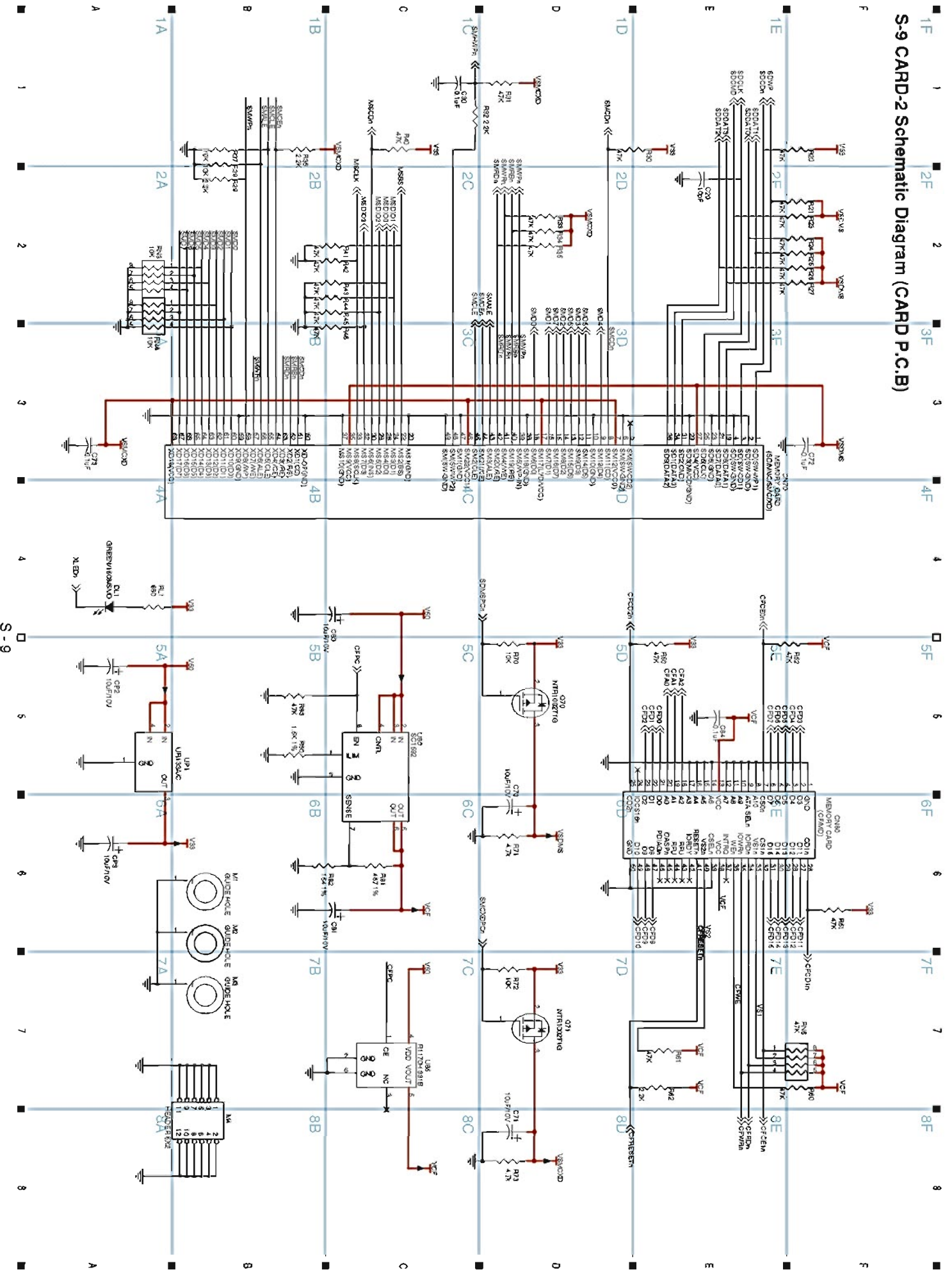

S-10 Circuit Waveforms

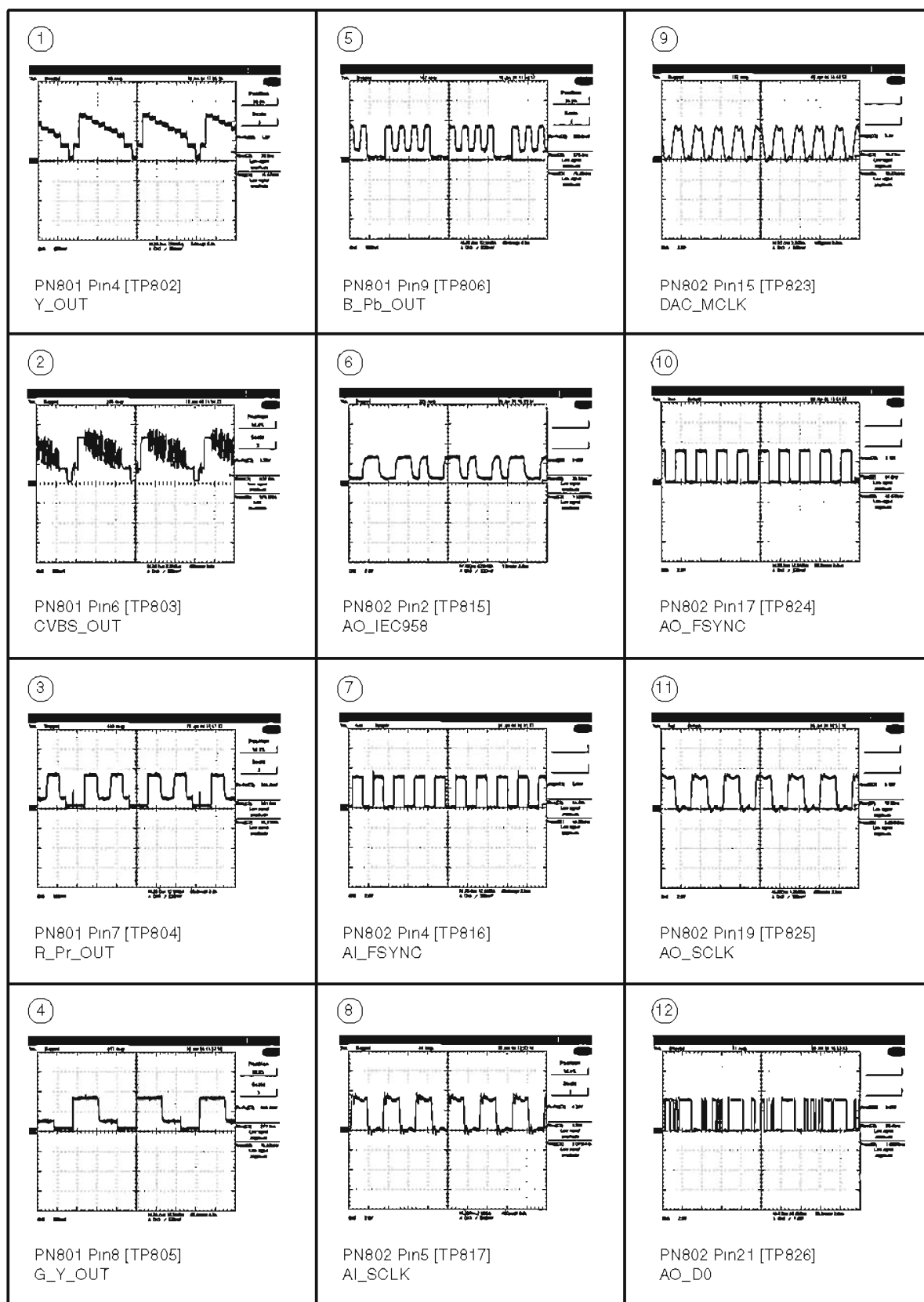

Circuit Board Diagrams
C-1 I/O Circuit Board Diagram

SIDE A

SIDE B

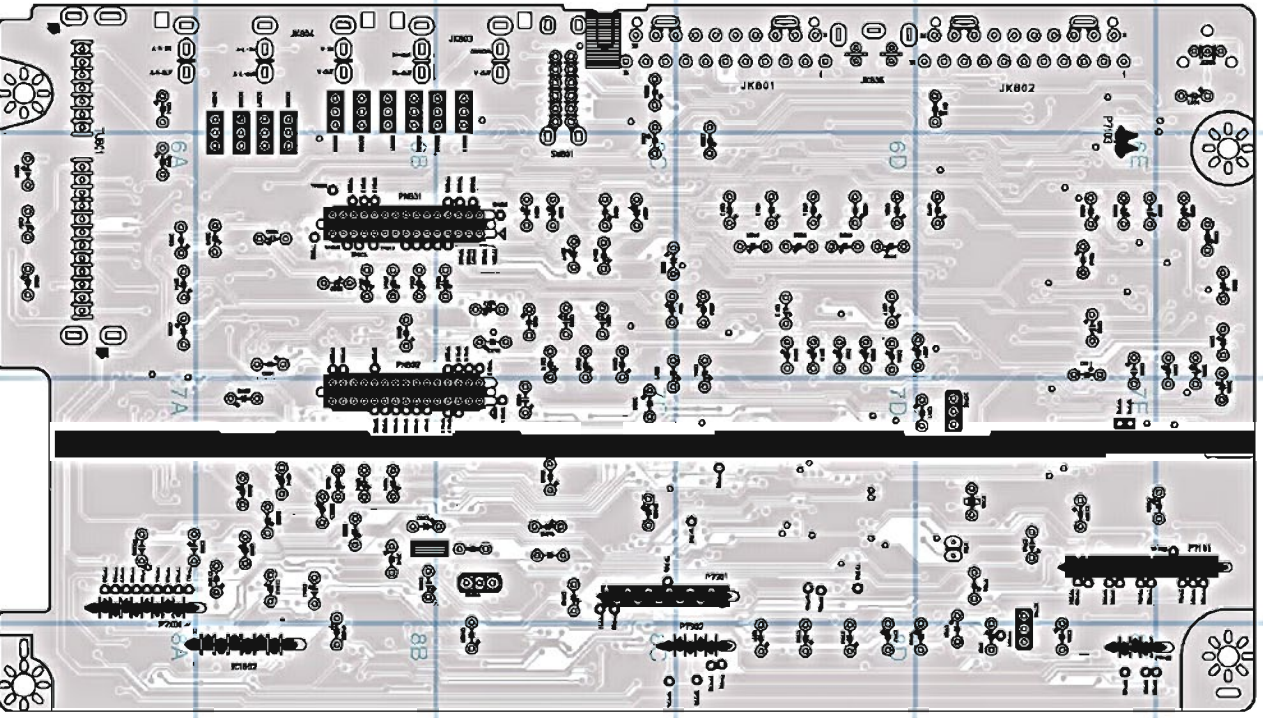
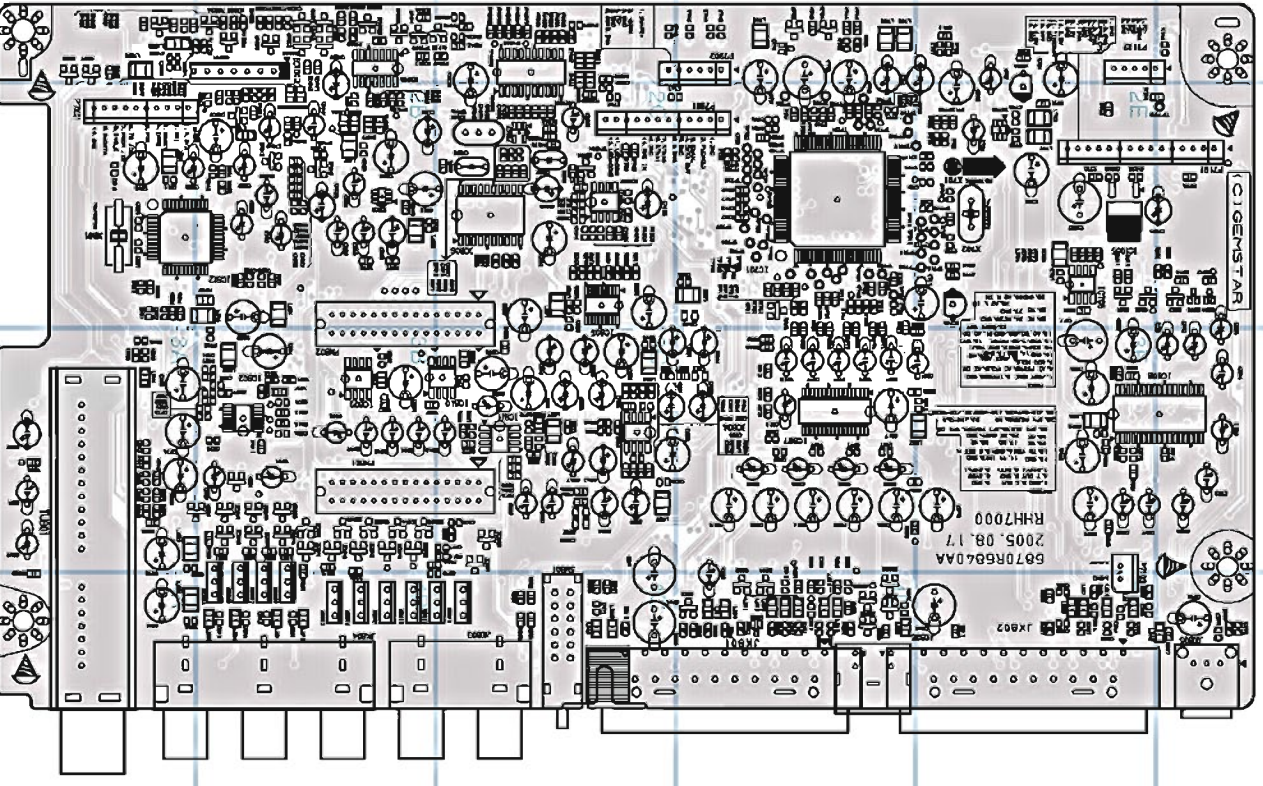

1F 1 2F 2 3F 3 4F 4 5F 5 6F 6 7F 7 8F 8
1A 1A 1B 1C 1D 1E 1F
2 2 3 4 5 6 7 8
A A
C-1

1F 1 2F 2 3F 3 4F 4 5F 5 6F 6 7F 7 8F 8

C-2 SMPS Circuit Board Diagram, C-3 JACK Circuit Board Diagram, C-4 LOADER Circuit Board Diagram, C-5 HDD Circuit Board Diagram

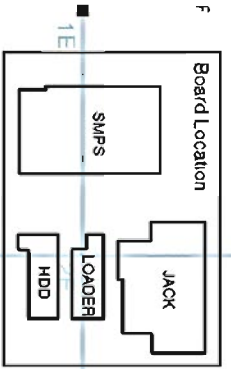

C-2 SMPS Circuit Board Diagram

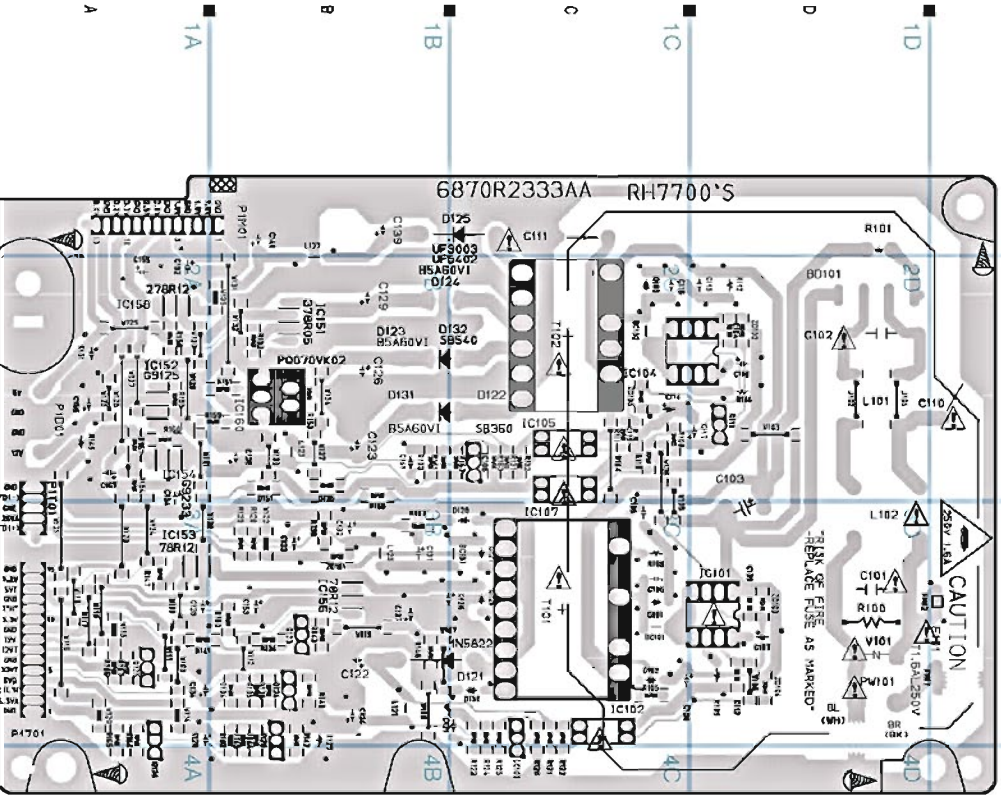

C-3 JACK Circuit Board Diagram

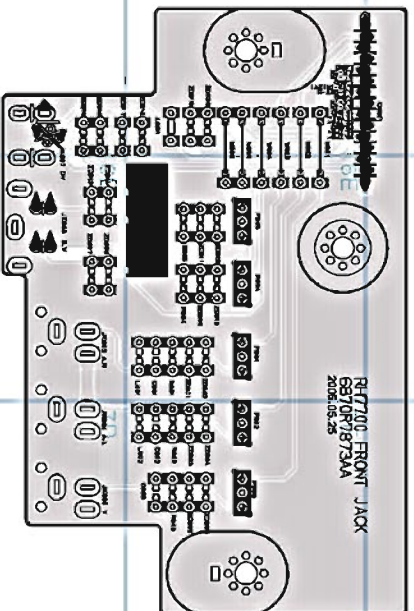

C-4 LOADER Circuit Board Diagram



C-5 HDD Circuit Board Diagram

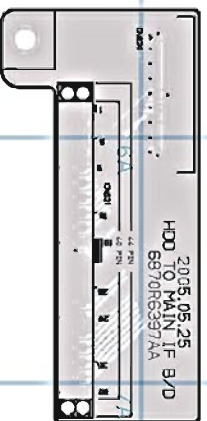

1A 1B 1C 1D 1E 2 3 4 5 6 7 8

2A 2B 2C 2D 2E 3A 3B 3C 3D 3E 4A 4B 4C 4D 4E 5A 5B 5C 5D 5E 6A 6B 6C 6D 6E 7A 7B 7C 7D 7E 8A 8B 8C 8D 8E

C-2

1F 1 2F 2 3F 3 4F 4 5F 5 6F 6 7F 7 8F 8

C-6 TIMER Circuit Board Diagram, C-7 KEY Circuit Board Diagram, C-8 CARD Circuit Board Diagram

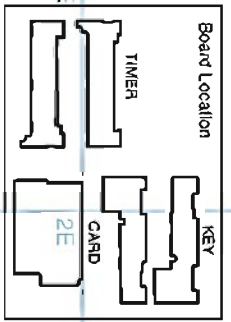

C-7 KEY Circuit Board Diagram

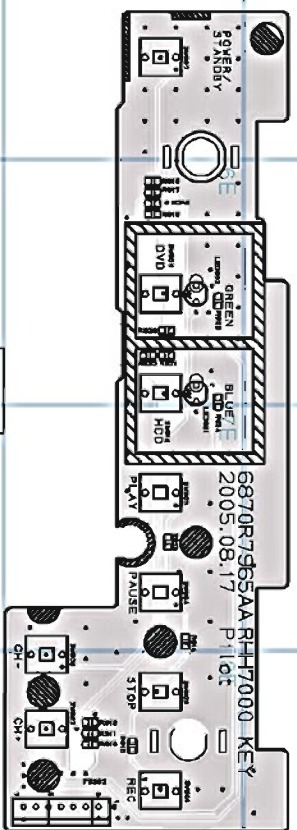

C-6 TIMER Circuit Board Diagram

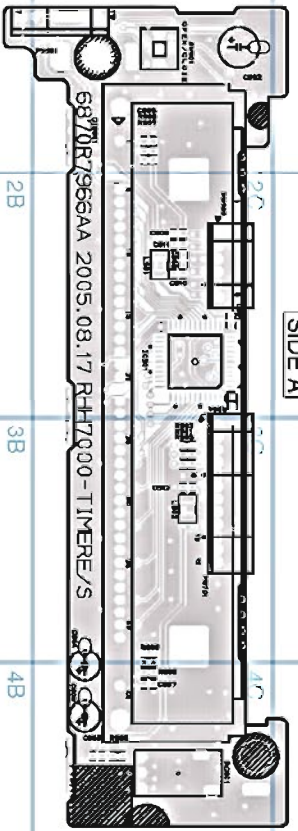

C-8 CARD Circuit Board Diagram

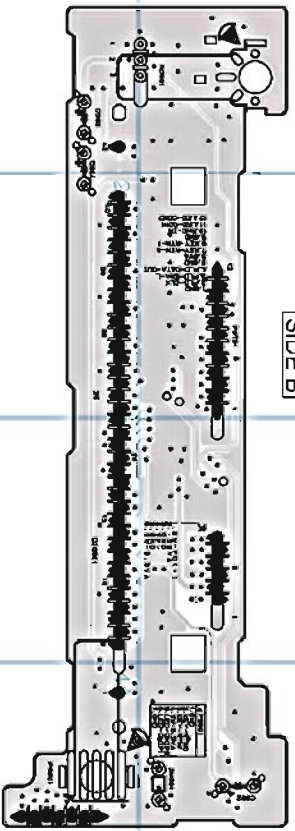
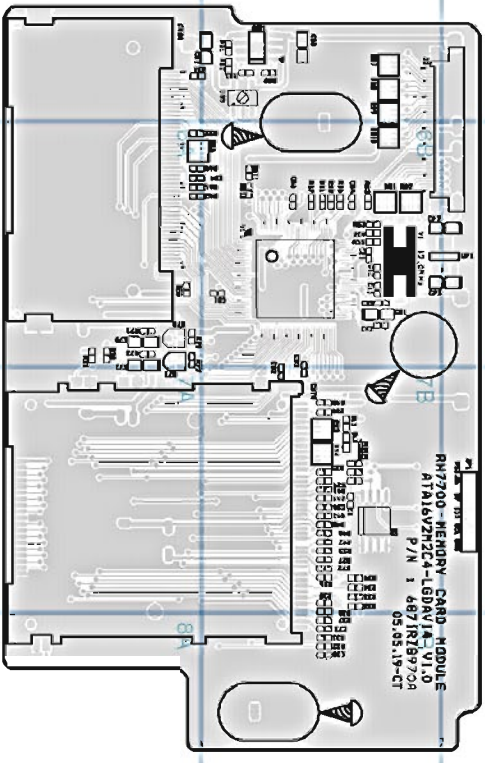

1A 1 2A 2 3A 3 4A 4 5A 5 6A 6 7A 7 8A 8

C-3

B Block Diagrams

B-1 Overall Block Diagram

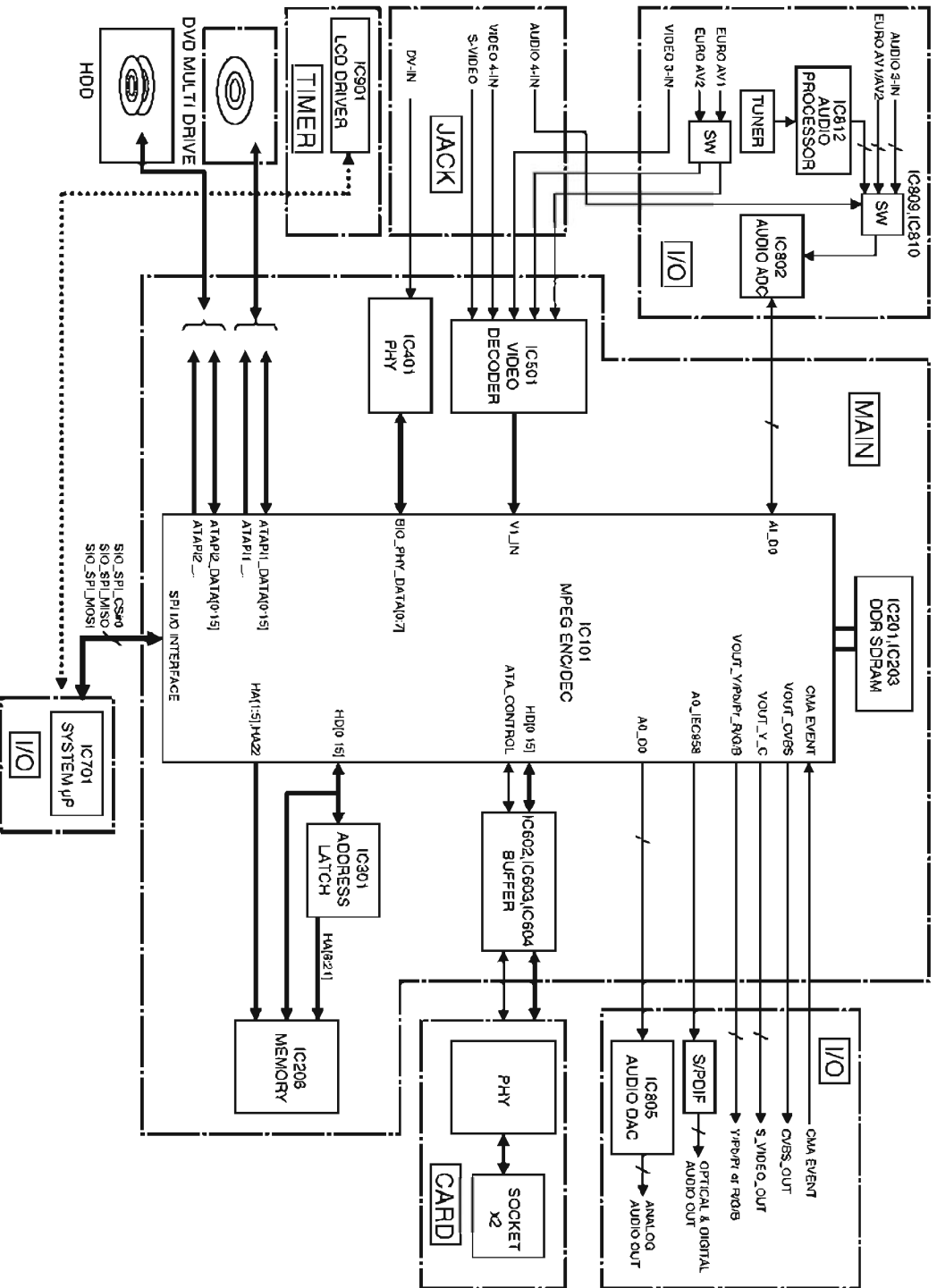

B-2 SMPS Circuit Block Diagram

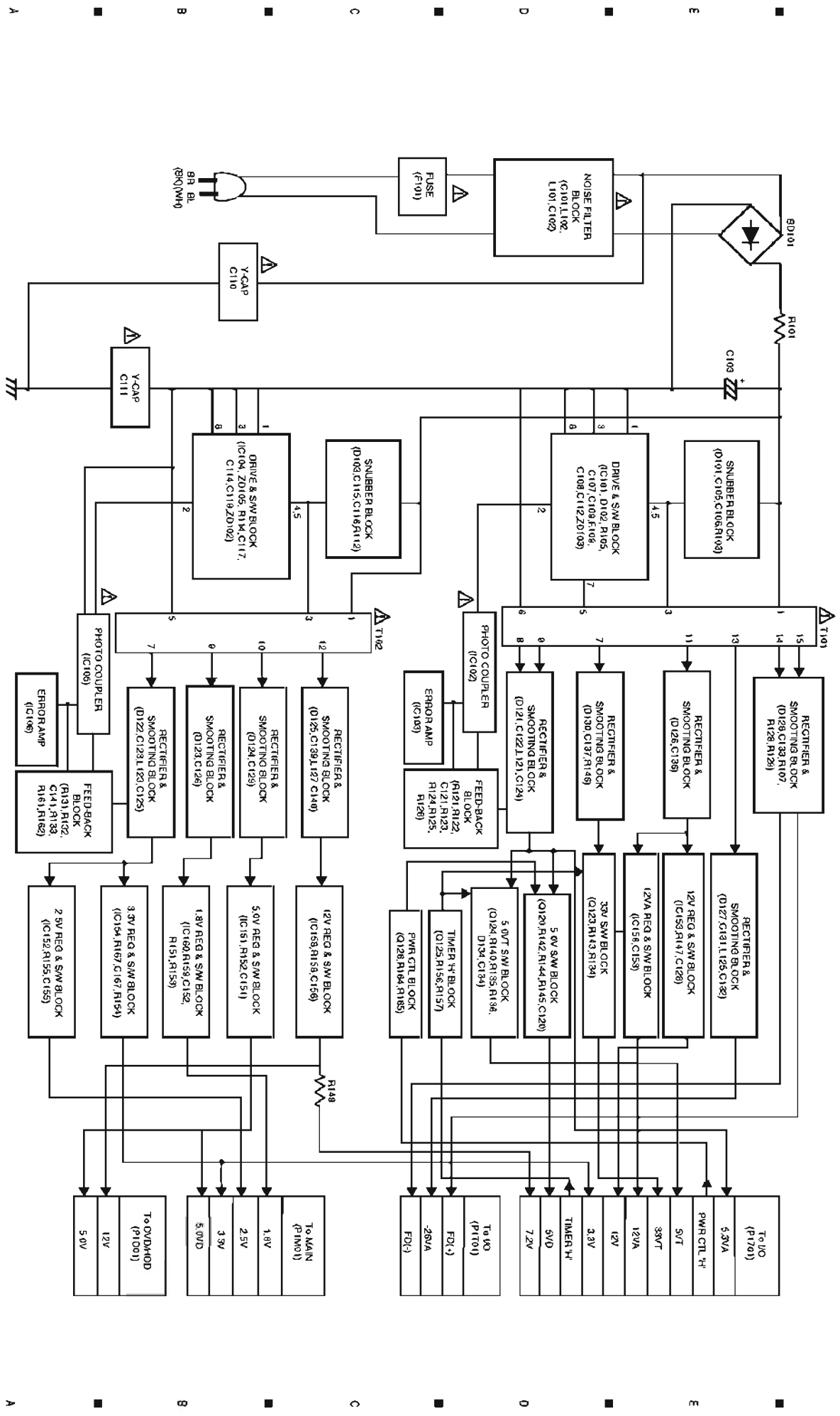

B-3 POWER (I/O Board) Circuit Block Diagram

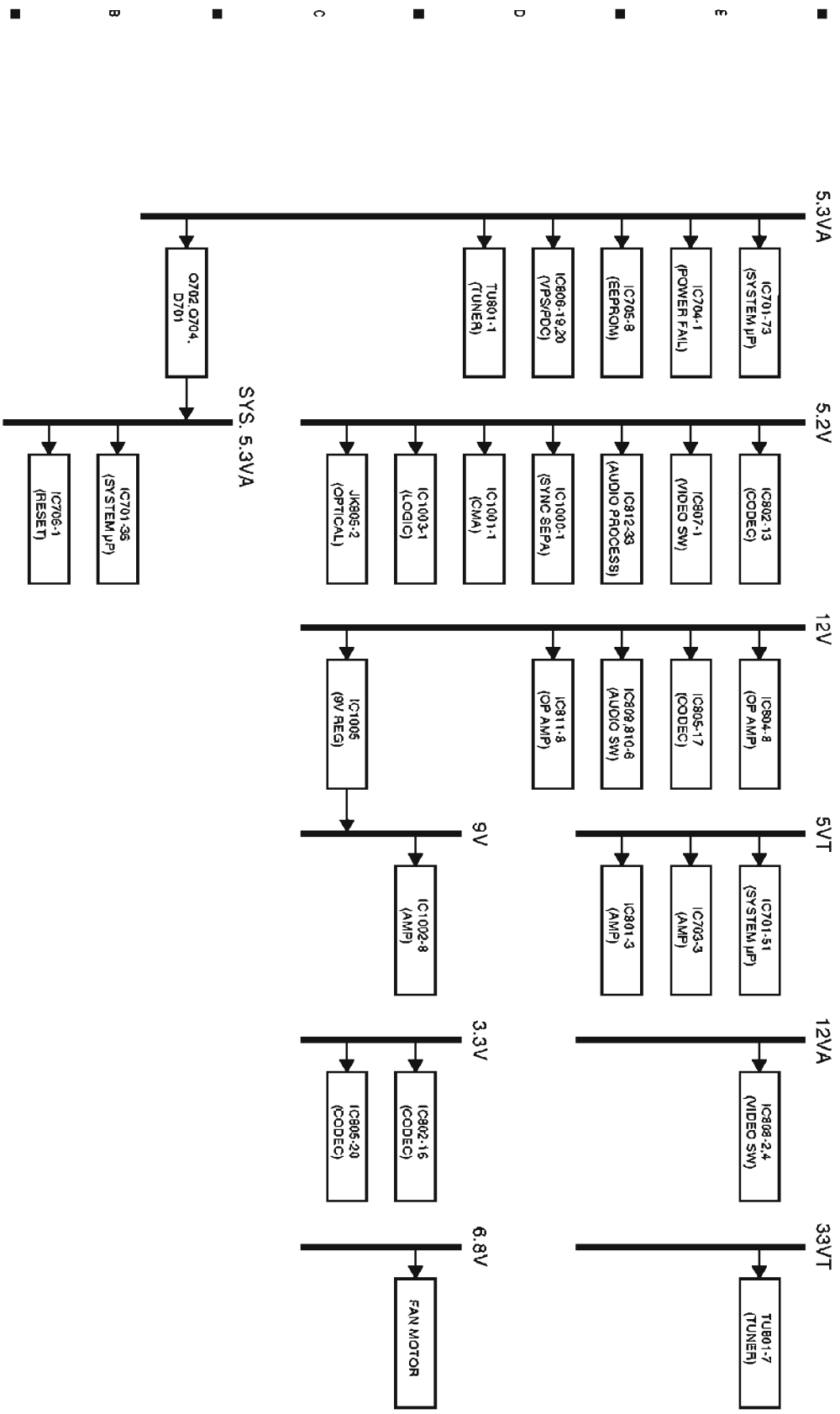

1 2 3 4 5 6 7 8

A B C D E F

B-3

B-4 AUDIO/VIDEO Circuit Block Diagram

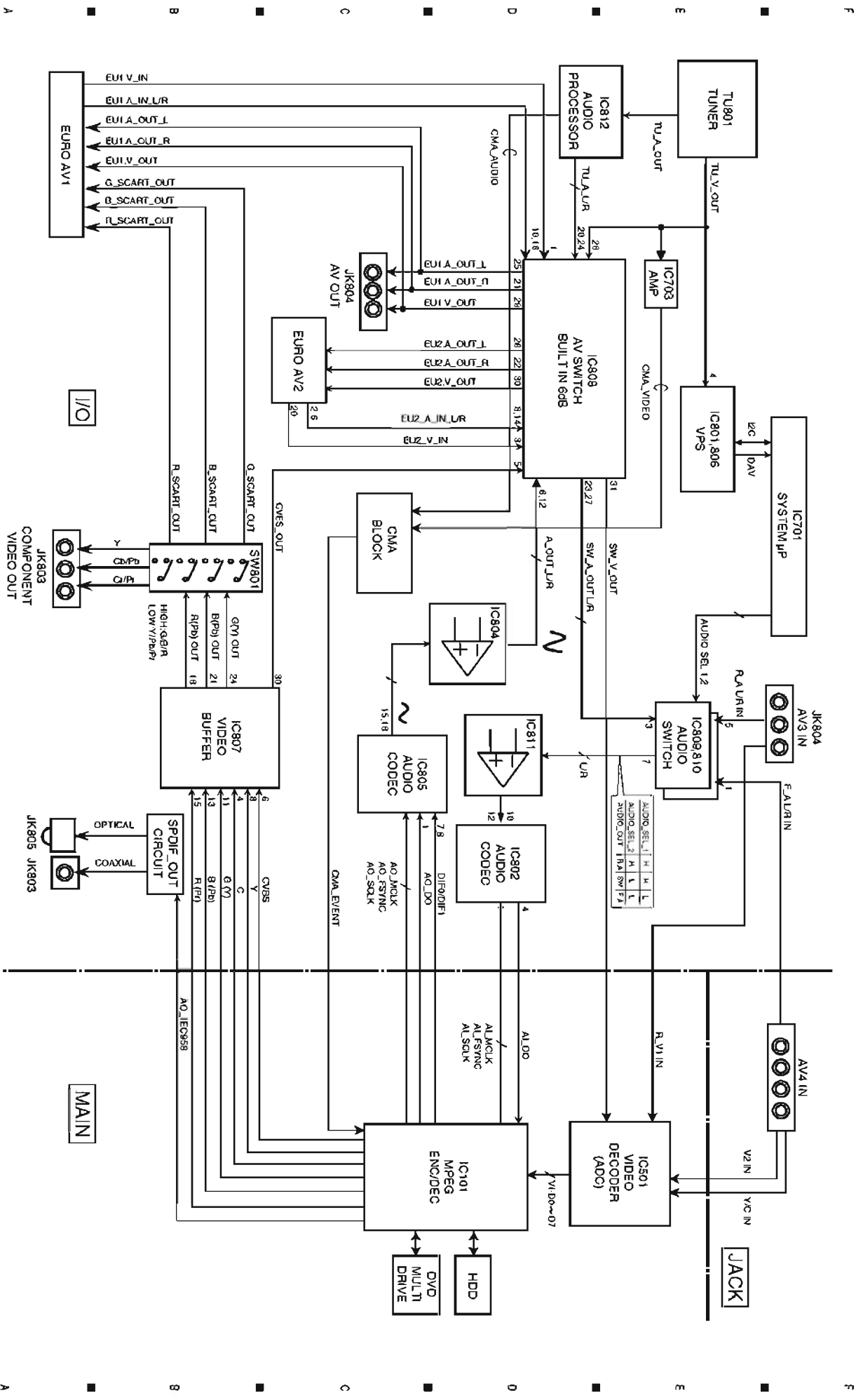

B-6 COMMERCIAL ADVANCE Circuit Block Diagram

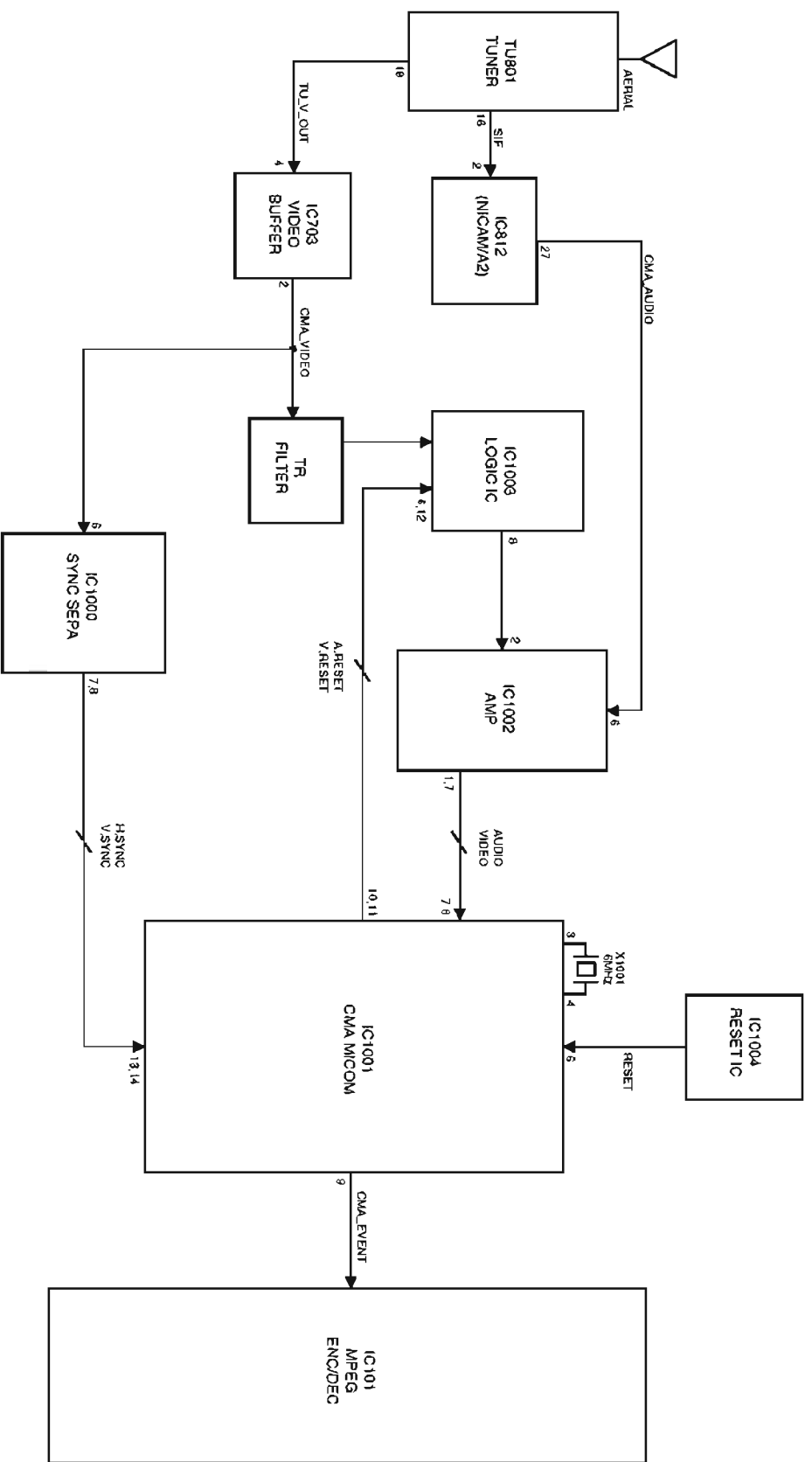

1 2 3 4 5 6 7 8 9 A B C D E F

B-6

HITACHI

Hitachi, Ltd. Tokyo, Japan
International Sales Division
THE HITACHI ATAGO BUILDING,
No. 15-12 Nishi Shinbashi, 2-Chome,
Minato-Ku, Tokyo 105-8430, Japan.
Tel: 03 35022111

HITACHI EUROPE LTD,

Whitebrook Park
Lower Cookham Road
Maidenhead
Berkshire
SL6 8YA

UNITED KINGDOM

Tel: 01628 643000
Fax: 01628 643400
Email: consumer-service@hitachi-eu.com

HITACHI EUROPE S.A.

364 Kifissias Ave. & 1, Delfon Str.
152 33 Chalandri
Athens

GREECE

Tel: 1-6837200
Fax: 1-6835964
Email: service.hellas@hitachi-eu.com

HITACHI EUROPE GmbH

Munich Office
Domacher Strasse 3
D-85622 Feldkirchen bei München

GERMANY

Tel: +49-89-991 80-0
Fax: +49-89-991 80-224
Hotline: +49-180-551 25 51 (12ct/min)
Email: HSE-DUS.service@hitachi-eu.com

HITACHI EUROPE S.A.

Gran Via Carlos III, 86, planta 5
Edificios Trade - Torre Este
08028 Barcelona

SPAIN

Tel: +34 93 409 2550
Fax: +34 93 491 3513
Email: atencion.cliente@hitachi-eu.com

HITACHI EUROPE srl

Via Tommaso Gulli N.39, 20147
Milano, Italia

ITALY

Tel: +39 02 487861
Tel: +39 02 38073415 Servizio Clienti
Fax: +39 02 48786381/2
Email: customerservice.italy@hitachi-eu.com

HITACHI Europe AB

Box 77 S-164 94 Kista

SWEDEN

Tel: +46 (0) 8 562 711 00
Fax: +46 (0) 8 562 711 13
Email: csgswe@hitachi-eu.com

HITACHI EUROPE S.A.S

Lyon Office
B.P. 45, 69671 BRON CEDEX

FRANCE

Tel: +33 04 72 14 29 70
Fax: +33 04 72 14 29 99
Email: france.consommateur@hitachi-eu.com

HITACHI EUROPE LTD (Norway) AB

STRANDVEIEN 18
1366 Lysaker

NORWAY

Tel: 67 5190 30
Fax: 67 5190 32
Email: csgnor@hitachi-eu.com

HITACH EUROPE AB

Egebækgård
Egebækvej 98
DK-2850 Nærum

DENMARK

Tel: +45 43 43 6050
Fax: +45 43 60 51
Email: csgnor@hitachi-eu.com

HITACHI EUROPE AB

Neopoli / Niemenkatu 73
FIN-15140 Lahti

FINLAND

Tel: +358 3 8858 271
Fax: +358 3 8858 272
Email: csgnor@hitachi-eu.com

Hitachi Europe Ltd

Bergensesteenweg 421
1600 Sint-Pieters-Leeuw

BELGIUM

Tel: +32 2 363 99 01
Fax: +32 2 363 99 00
Email: sofie.van.bom@hitachi-eu.com

HITACHI EUROPE LTD

Na Sychrove 975/8
101 27 Praha 10 – Bohdalec

CZECH REPUBLIC

Tel: +420 267 212 383
Fax: +420 267 212 385
Email: csgnor@hitachi-eu.com

www.hitachidigitalmedia.com