

HITACHI

SERVICE MANUAL

TK

NO. 9901E

DV-P250U/(PX)
DV-P250E/(UK)
DV-P250A/(M)/(S)/(AU)
DV-P250C

ADVICE

Please carefully read this guide before using the device. The Hitachi DVD Player has been designed to prevent fire, electrical shock, injury, or harmful radiation. It has been legally fabricated in accordance with the Electrical Appliances Act. Therefore, when using the device, please follow advice in this service guide to keep it safe to use.

1. In brief

DV-P250 is a device for DVD playback.

This device is to be used by connecting it to the video input terminal of a TV set.



2. Features

- Disc navigation system facilitates program search.
- Speedy operation by 2x speed drive.

SPECIFICATIONS AND PARTS ARE SUBJECT TO CHANGE FOR IMPROVEMENT.

DVD PLAYER



July 1999 Digital Media Products Division, Tokai

PRECAUTIONS FOR SAFETY (Please follow.)





Before undertaking repair work, please read through this [Precautions for safety].

The following points should be observed in order to prevent accidents from happening and to ensure the safety of the device.

- Degrees of danger or damage that can be caused by faulty operation are indicated by the following marks:

 <b style="font-size: 1.2em;">WARNING	Under this mark, there is "Possible death or serious injury".
 <b style="font-size: 1.2em;">CAUTION	Under this mark, there is "Possible injury or material damage".

- The following marks identify actions to be taken:

	This mark indicates items to which 'You should pay attention'.		This mark indicates items 'You have to accomplish'.
	This mark indicates: 'You should be cautious of electric shock'.		This mark indicates 'Forbidden items'.







 <h2 style="margin: 0;">WARNING</h2>	
<p><input type="checkbox"/> You should pay attention.</p> <p style="margin-left: 20px;">Where a special attention is required, it is indicated by a label or stamp. For example, on the cabinet, chassis, or parts. Please respect the indicated items and the 'Precautions for use' of the manual.</p> <p></p>	<p><input type="checkbox"/> The original part installation and wiring route shall be restored.</p> <p style="margin-left: 20px;">For safety, some parts are insulated by a tube or a tape, or installed without contact with substrate. The internal wiring is kept a distance from hot or high voltage parts by clamps or routing. Please restore them as initially done to prevent electric shock or fire from happening.</p> <p></p>
<p><input type="checkbox"/> You should be cautious against electric shock.</p> <p style="margin-left: 20px;">Please be careful during operations because there are high voltage and recharging parts inside. An electric shock or death may happen by touching them. When disassembling, assembling, or replacing a part, the power plug has to be pulled off. Touching by error a powered part may cause an electric shock, death, or injury.</p> <p></p>	<p><input type="checkbox"/> Please check safety after servicing.</p> <p style="margin-left: 20px;">Please check if dismantled screws, parts, and wires are reinstalled as before and if the area surrounding the repair is damaged. Please also measure insulation resistance with a ohmmeter and to confirm that it is more than 20MΩ. There is risk of electric shock or fire if the insulation resistance is less than 20MΩ.</p> <p></p>
<p><input type="checkbox"/> Please use designated parts.</p> <p style="margin-left: 20px;">Parts are characterized by unflammability and voltage resistance. Therefore, parts having these same characteristics must be used in replacement. Especially for parts important in insuring safety, identified by  in the schematic or parts list, a part with the identical part number shall be used. If a part with a different part number is used, an electric shock or a fire may occur.</p> <p></p>	

Table Of Contents

Chapter 1 System Introduction

System Specification	1
Hitachi DV-P250E	1
Hitachi DV-P250U/DV-P250A/DV-P250C	2
ACER DVD-5500/DVD-5300	3
ACER DVD-5100	4
System Outlook	5
Front Panel	5
Rear Panel	6
Description of adopted new technology	9
Digital signal circuit	9
Video circuit (DEC substrate)	10
VIDEO OUTPUT CIRCUIT (RJK substrate)	13
AUDIO CIRCUIT	13
KARAOKE CIRCUIT	16
FRONT (FSW) SUBSTRATE CIRCUIT	18
POWER SUPPLY CIRCUIT	18
CLOCK CIRCUITS	19
Troubleshooting	22
VIDEO CIRCUIT	22
AUDIO CIRCUIT	23
KARAOKE CIRCUIT	24
About System Reset Function	25
System Utility	25

Chapter 2 Removal and Replacement

Preliminaries before disassembling machines	27
Before You Begin	27
Disassembly Procedures	29
Removing the Top Cover	29
Removing the FootStand	29
Removing the Front Panel	30
Removing the MPEG Control Board	31
Removing the Power Supply Board	32
Removing the DVD-ROM Drive	32
Removing the Outlet Board	33
Removing the Front Panel Control Boards	34
Connector Setting	36

Appendix A Schematics

DEC Board (A side)	37
DEC Board (B side)	38
RJK Board (A side)	39
RJK Board (B side)	40
FSW/MVR/FJK Board (A side)	41
FSW/MVR/FJK Board (B side)	42
System Block Diagrams	43
Exploded Diagram	44
Replacement Parts List (DV-P250)	45

System Introduction

System Specification

Hitachi DV-P250E

Specification	
General	Model DV-P250E Operating laser Semi-conductor laser : Wave length 650nm(DVD) / 780nm(CD,VCD) Power supply AC230V, 50Hz Power consumption 27W Weight 3.9 Kg Overall size 434 (W) x 315 (D) x 98 (H) mm Allowable operating temperature +5°C~+35°C Allowable operating humidity 15~75% (no condensation)
AV connector output terminal	AV connector output 21-pin connector This connector provides the video and signals for connection to a color video TV monitor (or TV set) which has an 'AV CONNECTOR' terminal.
S Video output terminal	Y output level 1Vp-p (75Ω) C output level NTSC : 0.286Vp-p (75Ω) PAL : 0.3Vp-p (75Ω) Output terminal S terminal
Video output	Output level 1 Vp-p (synchronous when loaded at 75Ω) Output terminal pin jack
Audio output	Output level 200mVrms (1KHz, -20dB) Analog audio output 2 system (pin jack x 4) Sound characteristics : Frequency characteristics CD : 4Hz~20KHz (EIAJ) DVD : 4Hz~22KHz (48K sampling) 4Hz~44KHz (96K sampling) SN ratio 110 dB Dynamic range 100dB Total harmonic distortion rate 0.003% Wow flutterics Measurement limit less than (±0.001% W.PEAK)(EIAJ)
Other terminals	Digital audio output optical/coaxial Coaxial terminal : 1 (DTS/AC-3/MPEG2, AC3, LPCM, OFF commutable) Optical connector : 1
Accessories	Remote control unit 1 Single 'AAA' battery 2 AV cord 1 Power cord 1

Hitachi DV-P250U/DV-P250A/DV-P250C

Specification	
General	Model DV-P250U/DV-P250A/DV-P250C Operating laser Semi-conductor laser : Wave length 650nm(DVD) / 780nm(CD,VCD) Power supply DV-P250U : AC120V, 60Hz DV-P250U (PX), DV-P250A, DV-P250C : AC110-240V, 50/60 Hz Power consumption27W Weight3.9 Kg Overall size 434 (W) x 315 (D) x 98 (H) mm Allowable operating temperature +5°C~+35°C Allowable operating humidity 15~75% (no condensation)
Component output terminal	Y output level 1 Vp-p (75Ω) P _B output level NTSC : 0.7 Vp-p (75Ω) PAL : 0.698 Vp-p (75Ω) P _R output level NTSC : 0.7 Vp-p (75Ω) PAL : 0.698 Vp-p (75Ω) Output terminal pin jack
S Video output terminal	Y output level 1Vp-p (75Ω) C output level NTSC : 0.286Vp-p (75Ω) PAL : 0.3Vp-p (75Ω) Output terminal S terminal
Video output	Output level 1 Vp-p (synchronous when loaded at 75Ω) output terminal pin jack
Audio output	Output level 200mVrms (1KHz, -20dB) Mixed 2ch output 1 system (pin jack x 2) 5.1ch output 1 system (pin jack x 6) Sound characteristics : Frequency characteristics CD : 4Hz~20KHz (EIAJ) DVD : 4Hz~22KHz (48K sampling) 4Hz~44KHz (96K sampling) SN ratio 110 dB Dynamic range 100dB Total harmonic distortion rate 0.003% Wow/flutter Measurement limit less than (±0.001% W.PEAK)(EIAJ)
Other terminals	Digital audio output optical/coaxial Coaxial terminal : 1 (DTS/AC-3/MPEG2, LPCM, OFF commutable) Optical connector : 1
Accessories	Remote control unit 1 Single 'AAA' battery 2 AV cord 1 Power cord 1 AC socket (DV-P250U (PX) only) 1

ACER DVD-5500/DVD-5300

Specification	
General	Model DVD-5500/DVD-5300 Operating laser Semi-conductor laser : Wave length 650nm(DVD) / 780nm(CD,VCD) Power supply Taiwan : DVD-5500/5300 : AC120V, 60Hz Hong Kong : DVD-5500/5300 : AC110-240V, 50/60 Hz Power consumption 27W Weight 3.9 Kg Overall size 434 (W) x 315 (D) x 98 (H) mm Allowable operating temperature +5°C~+35°C Allowable operating humidity 15~75% (no condensation)
Component output terminal (DVD-5500 only)	Y output level 1 Vp-p (75Ω) P _B output level NTSC : 0.7 Vp-p (75Ω) PAL : 0.698 Vp-p (75Ω) P _R output level NTSC : 0.7 Vp-p (75Ω) PAL : 0.698 Vp-p (75Ω) Output terminal pin jack
S2 Video output terminal	Y output level 1Vp-p (75Ω) C output level NTSC : 0.286Vp-p (75Ω) PAL : 0.3Vp-p (75Ω) Output terminal S terminal (DVD-5500 S terminal x 2)
Video output	Output level 1 Vp-p (synchronous when loaded at 75Ω) output terminal pin jack (DVD-5500 pin jack x 2)
Audio output	Output level 200mVrms (1KHz, -20dB) Mixed 2ch output 1 system (pin jack x 2) 5.1ch output 1 system (pin jack x 6) Sound characteristics : Frequency characteristics CD : 4Hz~20KHz (EIAJ) DVD : 4Hz~22KHz (48K sampling) 4Hz~44KHz (96K sampling) SN ratio 110 dB Dynamic range 100dB Total harmonic distortion rate 0.003% Wow/flutter Measurement limit less than (±0.001% W.PEAK)(EIAJ)
Other terminals	Digital audio output optical/coaxial Coaxial terminal : 1 (DTS/AC-3/MPEG2, LPCM, OFF commutable) Optical connector : 1
Accessories	Remote control unit 1 Single 'AAA' battery 2 AV cord 1 Power cord 1

ACER DVD-5100

Specification	
General	Model DVD-5100 Operating laser Semi-conductor laser : Wave length 650nm(DVD) / 780nm(CD,VCD) Power supply AC120V, 60Hz Power consumption27W Weight.....3.9 Kg Overall size434 (W) x 315 (D) x 98 (H) mm Allowable operating temperature +5°C~+35°C Allowable operating humidity 15~75% (no condensation)
S Video output terminal	Y output level 1Vp-p (75Ω) C output level NTSC : 0.286Vp-p (75Ω) PAL : 0.3Vp-p (75Ω) Output terminalS terminal
Video output	Output level 1 Vp-p (synchronous when loaded at 75Ω) output terminal pin jack
Audio output	Output level 200mVrms (1KHz, -20dB) Analog audio output 2 system (pin jack x 4) Sound characteristics : Frequency characteristicsCD : 4Hz~20KHz (EIAJ) DVD : 4Hz~22KHz (48K sampling)4Hz~44KHz (96K sampling) SN ratio 110 dB Dynamic range 100dB Total harmonic distortion rate0.003% Wow fluttertics Measurement limit less than (±0.001% W.PEAK)(EIAJ)
Other terminals	Digital audio output optical/coaxial Coaxial terminal : 1 (DTS/AC-3/MPEG2, LPCM, OFF commutable)
Accessories	Remote control unit 1 Single 'AAA' battery 2 AV cord 1 Power cord 1

System Outlook

Front Panel

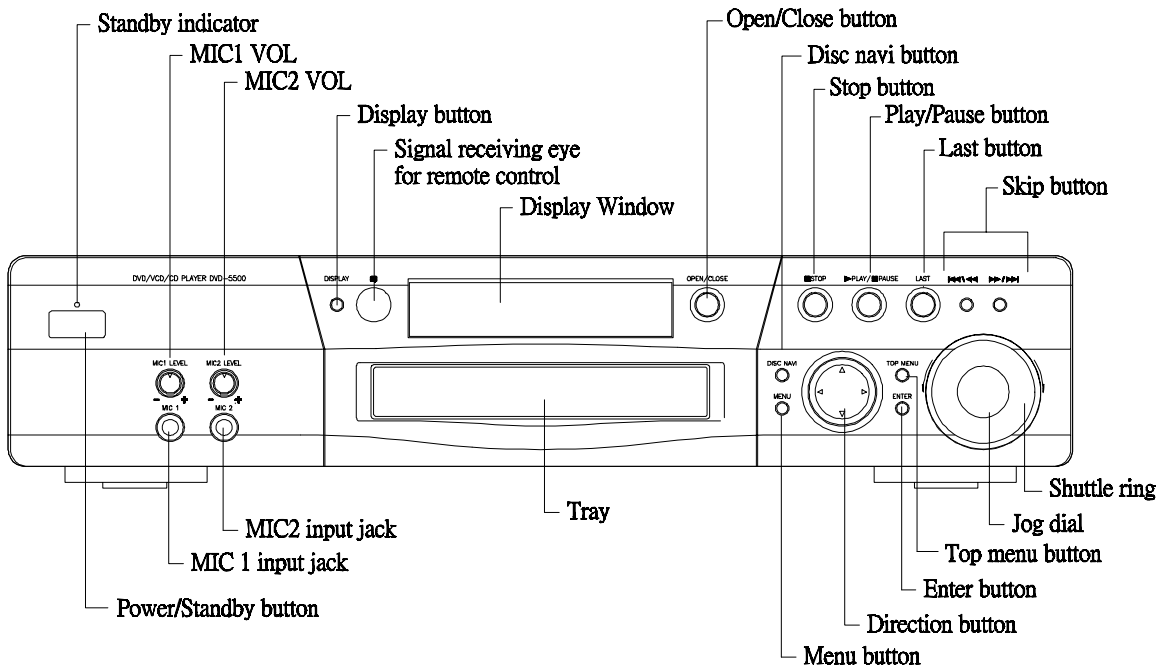

NOTE: The Karaoke functions (includes MIC1 VOL/MIC2 VOL/MIC1 input jack/MIC2 input jack) are only available at Acer DVD-5500 and DVD-5300 models.

NOTE: The Jog dial and Shuttle ring functions are only available at Acer DVD-5500 and Hitachi DV-P250 models.

Display Window

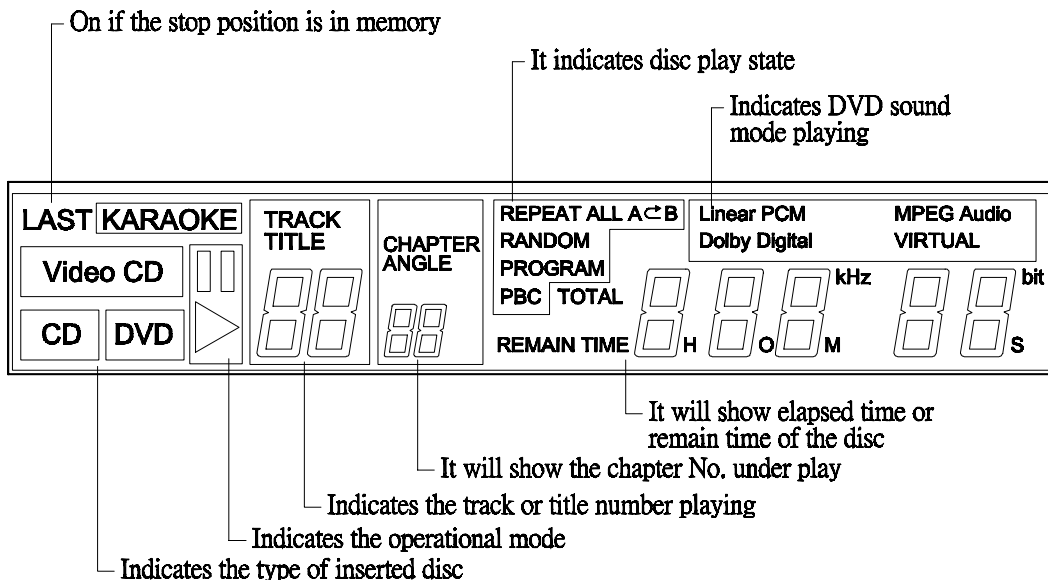

Rear Panel

ACER DVD-5500

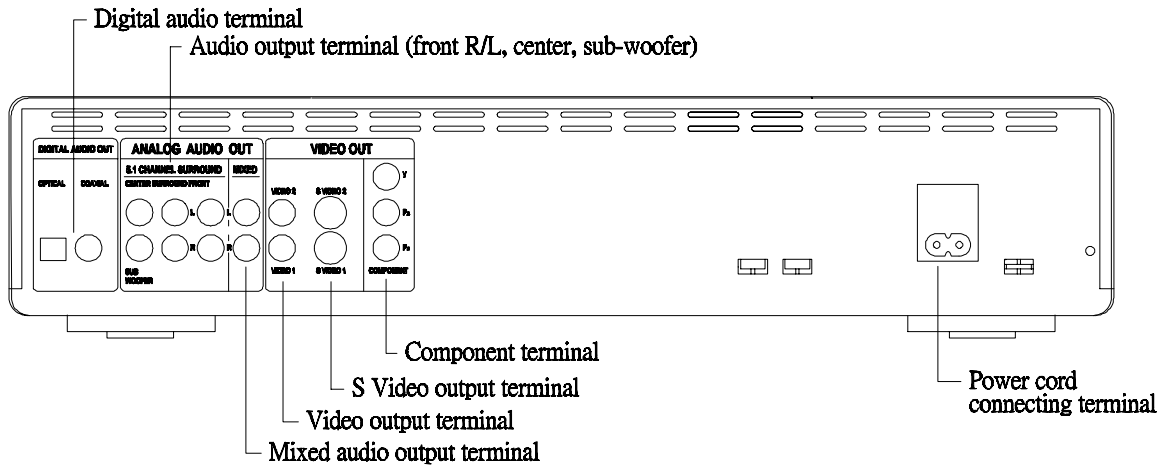

ACER DVD-5300

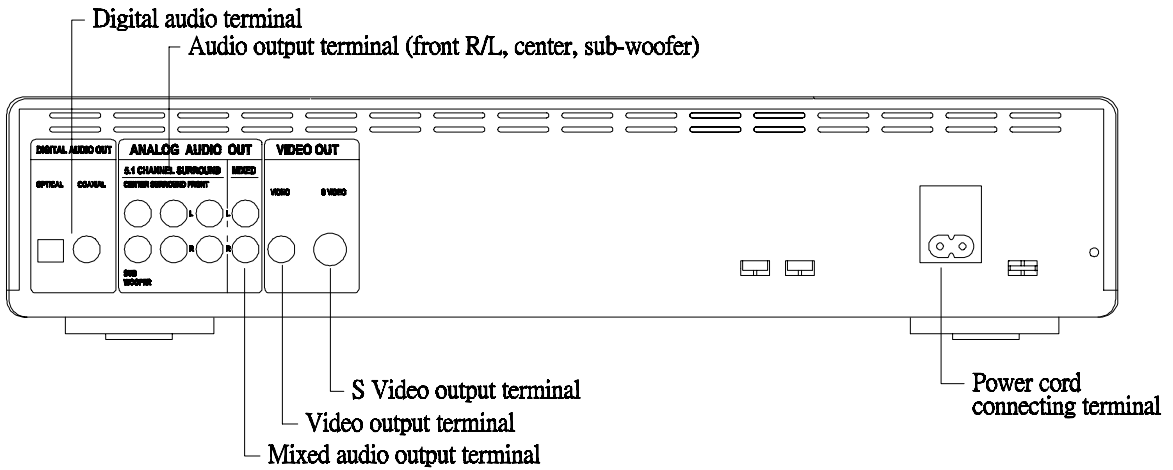

Acer DVD-5100

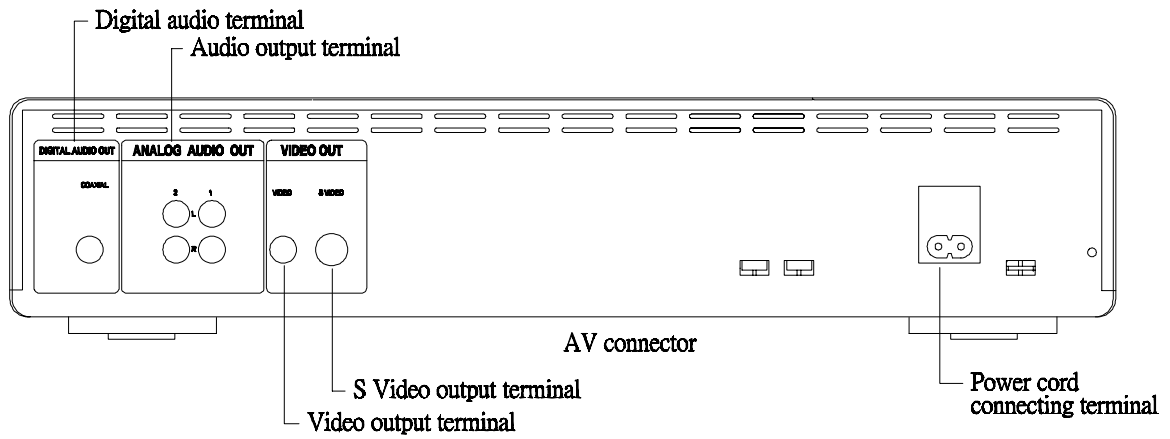

Hitachi DV-P250E

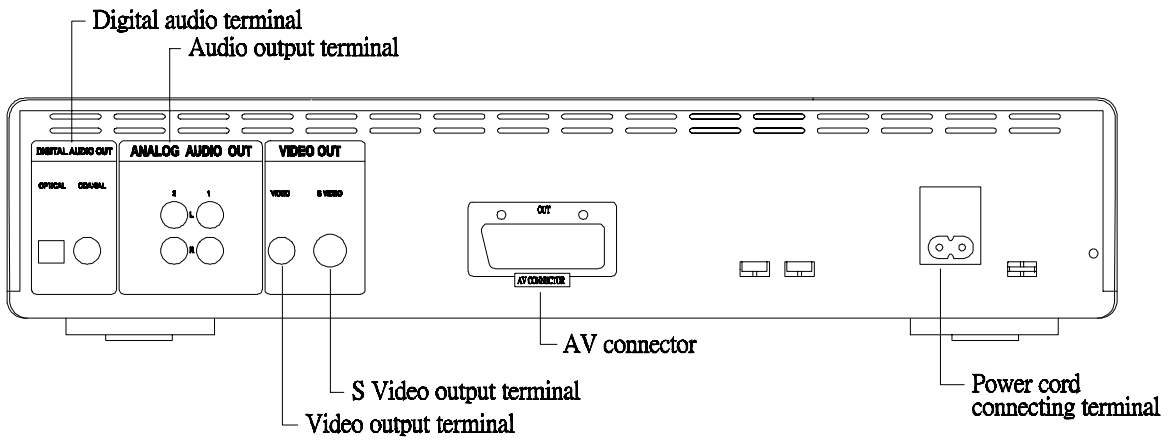

Hitachi DV-P250U/DV-P250A/DV-P250C

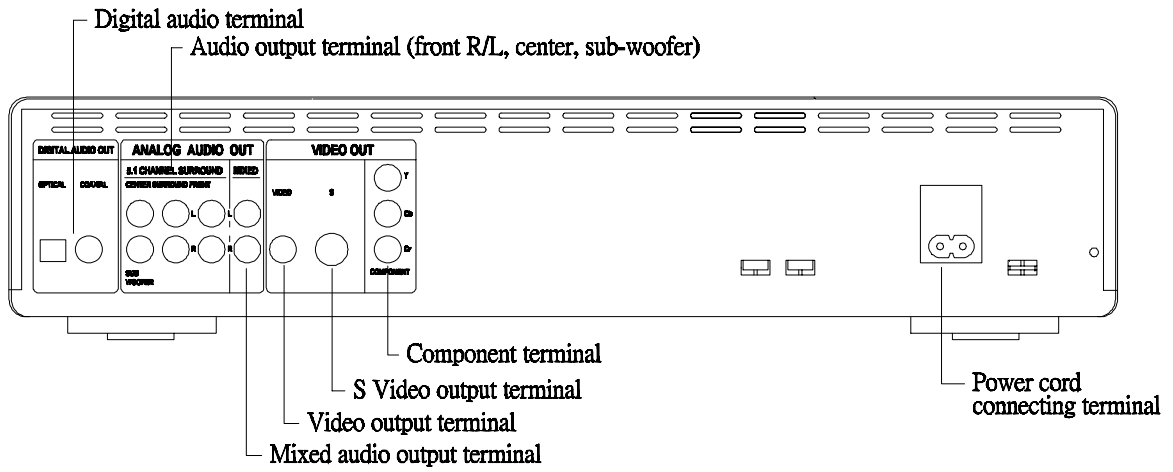

NOTE: For the different voltages of each area, the power connector has the following two types. The Power Connector type 2 is only for the areas of Taiwan and U.S.A. model. And the power connector type 1 is for the DV-P250U(PX) and others.

Power Connector type 1

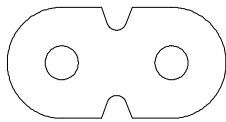

Power Connector type 2

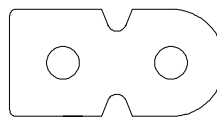

Description of adopted new technology

Digital signal circuit

Data Flow

The following figure shows the block diagram of digital signal circuit.

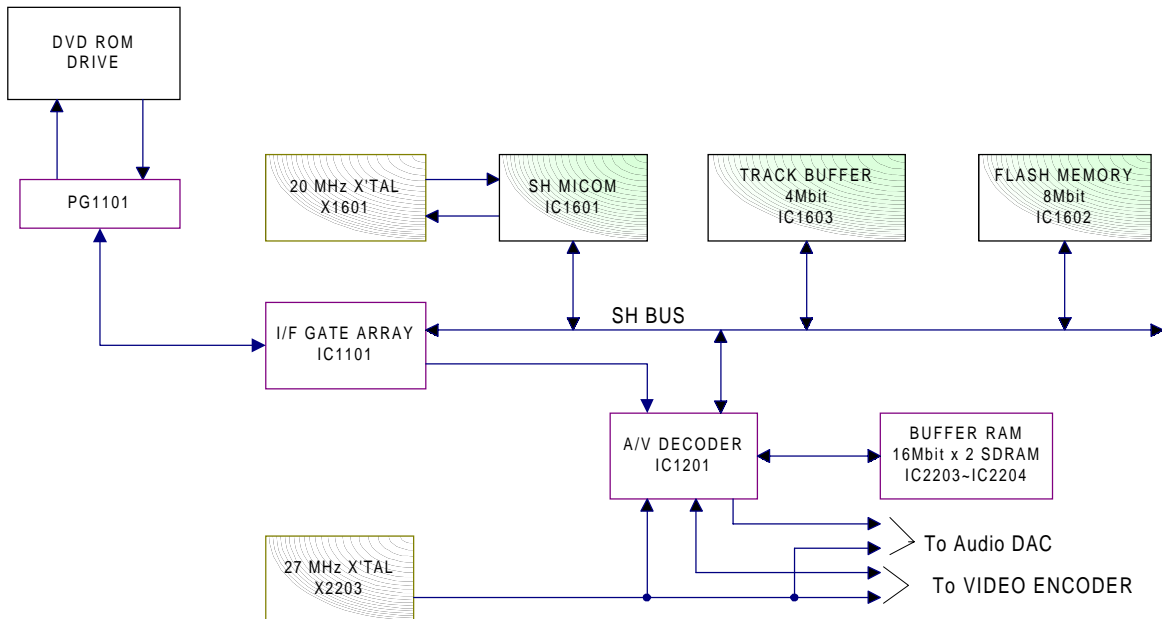

The disc data will be read by DVD ROM Drive then pass through I/F gate array (IC1101). The read data will then be stored in the track buffer by SH MICOM(IC1601). Then the stored data will be read out from the track buffer in response to the demand by A/V decoder (IC1201) and input in A/V decoder through I/F gate array. Finally, the A/V decoder will demodulate/decode the data according to their contents and output audio data to Audio DAC (IC1501~1504), and video data to Video encoder (IC2202)

Reference Clock of each IC

IC	Reference Clock
IC1101 I/F GATE ARRAY	20MHz clock generated by SH MICOM
IC1601 SH MICOM	System clock of X1601 20MHz X'TAL, SH
IC1602 FLASH MEMORY	Nil (Control signal is generated by SH MICOM)
IC1603 TRACK BUFFER	Nil (Control signal is generated by SH MICOM)
IC1201A/V DECODER	System clock and video interface clock are input from X2203 27MHz X'TAL. Audio interface clock is output from 169 pin named DA-XCK.

Functions of each IC

No.	IC	Functions	Operating Voltage
1	IC1101 I/F GATE ARRAY	Execute data transfer timings from ATAPI to track buffer, and from track buffer to A/V decoder.	5V
2	IC1601 SH MICOM	Execute data transfer, presetting and control of each IC.	5V
3	IC1602 FLASH MEMORY	Store memory for SH MICOM software	5V
4	IC1603 TRACK BUFFER	Buffer memory for data transfer	5V
5	IC1201 A/V DECODER	Execute decompression (decoding) of data compressed by MPEG	3.3V
6	IC2203~IC2204 BUFFER RAM	Memory used for decompression (decoding) of data compressed by MPEG and controlled by A/V decoder	3.3V

The following is the description of the functions of each IC:

- I/F GATE ARRAY (IC1101)**
It executes signal timing changes between SH MICOM (IC1601), DVD ROM drive I/F (PG1101), and A/V decoder (IC1201). It operates on 20MHz clock which is an output from SH MICOM.
- SH MICOM (IC1601)**
It transfers data and executes presetting and control of each IC.
Data transfer from DVD ROM drive I/F is done by setting a register of I/F gate array and by intermediary of I/F gate array.
In addition, it controls audio DAC ((IC1501~IC1504) and video encoder (IC2202), manages track buffer (IC1603) and flash memory (IC1602), and communicates with FL MICOM (IC1701).
With 20MHz XTAL(X1601) attached it pulses and is used as a system clock.
- FLASH MEMORY (IC1602)**
A 8Mbits flash memory is used. It stores SH MICOM program and its access is controlled by SH MICOM.
- TRACK BUFFER (IC1603)**
A 4Mbit DRAM is used. It stores data read out from disc. Its control is done by SH MICOM, and its data is read-written via I/F gate array. In addition a part of this buffer is used as the work area of SH MICOM.
- A/V DECODER (IC1201)**
Data input from track buffer via I/F gate array is separated into audio data and video data. MPEG compressed data are decompressed (decoded) and output as digital video and digital audio (AC-3). SH MICOM controls it via I/F gate array. System clock, clock of video interface signals, and clock of audio interface signals operate by inputting 27MHz respectively.
- BUFFER SDRAM (IC2203~IC2204)**
Two 16 Mbits SDRAM are used. A/V decoder controls it and it is used to decompress audio and video data compressed by MPEG.

Video circuit (DEC substrate)

8bit $YC_R C_B$ digital video stream (P) output from A/V decoder are input to video encoder ADV7172(IC2202). Video encoder is preset in master mode that generates reference signals and receives 27MHz from system clock X2203 and outputs H,V synchronous signals to A/V decoder.

By presetting of internal register, video encoder generates:

- NTSC (North America, Japan, Taiwan)
- PAL (Europe, Asia)

standard analog video signals.

Filter circuit eliminates high frequency components of analog video signals output from video encoder. Afterwards in S2 processor circuit DC voltage is superposed on C signals then output 3 types of video signals: composite video signals, Y/C(S2) video signals and YP_BP_R/RGB to RJK substrate via 17P connector (PG2201).

The following is a description of video circuit along signal flow:

Block Diagram of VIDEO ENCODER B1865A (IC2202) interior

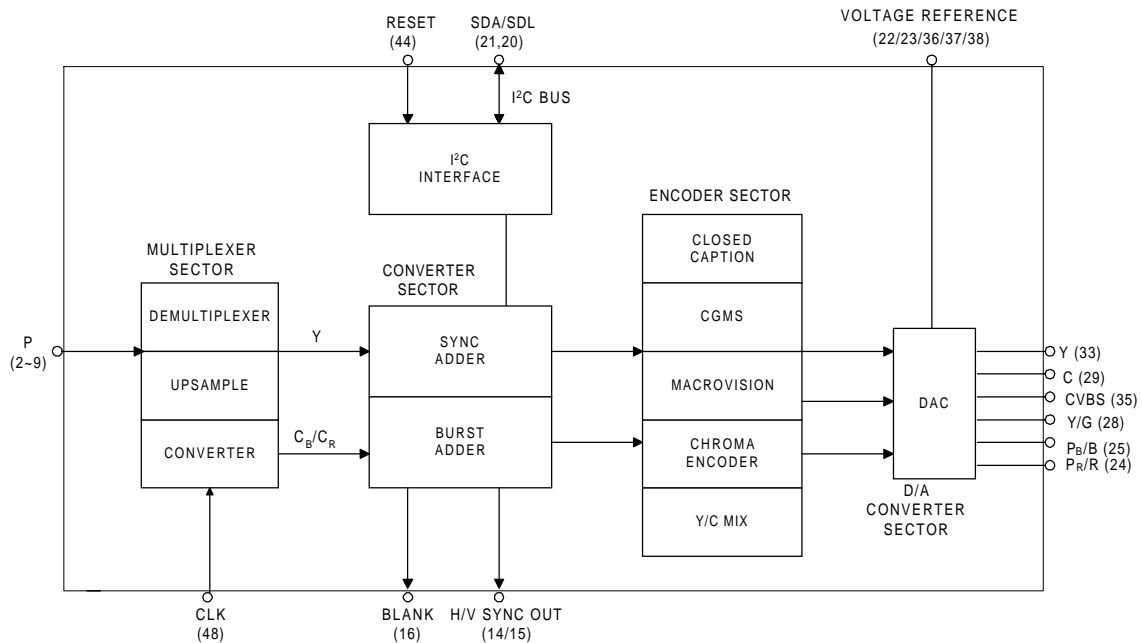

VIDEO ENCODER ADV7172 (IC2202)

1. MULTIPLEXER SECTOR

It transforms input digital video stream (Input at 2~9 pins) in 8bit parallel data then separates them in Y data and C_B/C_R data and changes simultaneously the rate (6.75MB/S->13.5MB/S).

2. CONVERTER SECTOR

It generates various internal timing signals with the synchronous signal as standard by adding synchronous signals generated in IC to Y data, according to the conditions set in the internal register or by adding BURST signals to C_B/C_R data. At the same time it outputs these synchronous signals to A/V decoder (Output at 14,15 pins). In addition, when power is turned ON, RESET signal (Input of L level at 44 pin) is input to reset the register in IC.

Moreover, writing in the internal register (presetting) is done via I2C BUS (20,21 pins).

3. ENCODER SECTOR

The following 1~3 data are inserted in VIDEO DATA according to preset conditions in the internal register:

- a. Closed caption
NTSC Mode: 21 lines and 284 lines/ PAL Mode: 22 lines and 335 ines.
- b. CGMS (Copy Guard Management System)
20 lines and 280 lines of NTSC.
- c. Macrovision Copy Prevention System
Finally it generates DIGITAL INTENSITY DATA, DIGITAL CHROMA DATA, and DIGITAL COMPOSITE DATA.

4. D/A CONVERTER (DAC)SECTOR

Constituted of 10bit DAC, it transforms DIGITAL VIDEO DATA to ANALOG VIDEO DATA for output. Under control of output voltage by DAC pins (22, 23, 36, 37, 38 pins), it output 3 kinds of ANALOG VIDEO SIGNALS:

- a. ANALOG COMPOSITE VIDEO SIGNALS (CVBS/35 pin), output voltage 1.0Vpp.
- b. ANALOG INTENSITY SIGNALS (Y/33 pin), output voltage 1.0Vpp.
- c. ANALOG CHROMA SIGNALS (C/29 pin), BURST part output voltage 286mVpp.
- d. ANALOG COMPONENT YP_BP_R/RGB.

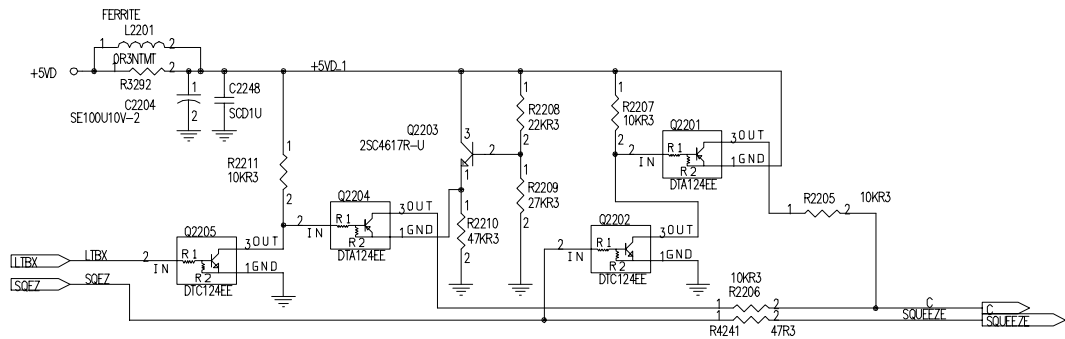

S2 Processing Circuit (only for Japan)

S2 is a standard used in wide television sets possessing screen size switching function in NTSC mode. By inputting VIDEO signals formed by superposing DC voltage on C signal at S input terminal, it switches automatically to TV display size. The DC voltage superposed on C signal varies according to the ASPECT RATIO of VIDEO SIGNALS.

1. Case of SQUEEZE SIGNAL (*1)

H-level voltage is input in SQUEEZE INPUT; Q2202 and Q2201 are powered and +4V DC voltage is superposed on C signal output line.

2. Case of LETTER BOX SIGNAL (*2)

H-level voltage is input in LETTER INPUT; Q2205, Q2204, and Q2203 are powered and +1.8V DC voltage is superposed on C signal output line.

1. *1: It is a laterally shrunk image information with 525 lines and an aspect ratio of 16:9 carried by the standard TV signal format of 525 lines and an aspect ratio of 4:3. When viewing on a 4:3 TV set, the image appears vertically oblong.
2. *2: It is a wide screen signal in the standard TV signal format of 525 lines and an aspect ratio of 4:3 with coexistence of upper and lower blank areas of 525 lines and an aspect ratio of 4:3 screen and the principal image area of 4:3 aspect ratio (line 53~232/316~495). When viewing on a 4:3 TV set, one sees black areas at the top and bottom of the screen.

VIDEO OUTPUT CIRCUIT (RJK substrate)

Analog composite video signals (CVBS), analog intensity signals (Y), analog chroma signals (C) and analog component signals ($Y_P B_P R/RGB$) are sent from DEC substrate to RJK substrate by passing through 17P connector (PG2201~CN1302). From RJK substrate, CVBS signals are output from output terminal J1307 and Y/C signals are output from output terminal J1302. Component signals are output from output terminal J1306 ($Y_P B_P R$) or J1361 (RGB).

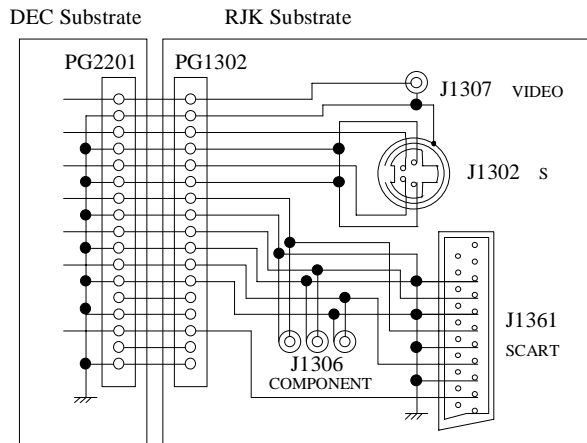

AUDIO CIRCUIT

Audio circuit is shown in page 15.

Audio circuit is composed of D/A converter sector (DEC substrate) that transforms digital audio signals output from A/V decoder (IC1201), analog processing sector (RJK substrate) that consists of an operational amplifier, and mute circuit (DEC substrate, RJK substrate) for stopping audio output when required.

1. D/A CONVERTER SECTOR (DEC substrate)

D/A converter sector is composed of IC1502 that receives and transforms digital audio signals from A/V decoder in analog signals.

IC1502 is a converter corresponding to FL and FR signals of sampling frequencies 44.1/48/96KHz and data lengths 16/20/24bit, and digital audio signals from A/V decoder is input at pin 2.

To these digital audio signals are inserted FL and FR signals in time sharing mode. When they are input in pin 1, they are separated in FL and FR signals by R clock and after transformation analog FL signals are output at pin 16 and FR signals at pin 13. Moreover, when there are no input signals at pin 2, a signal called ZERO MUTE is output to pin 21 to mute useless noises (See paragraph on MUTE CIRCUIT.)

Every functions of IC1502 is preset by MICOM and controlling signals from SH MICOM are input at pins 26, 27, and 28. As for presetting items, there are data length, sampling frequency, signal polarity, and de-emphasis.

2. ANALOG PROCESSING SECTOR (RJK substrate)

Analog processing sector is composed of operational amplifier IC1508 that is a filter and operational amplifier IC1510 that amplifies audio signals.

Filter portion is composed of RC low pass filter and IC1508 formed active low pass filter and there are 3 sections. The diagram below shows its filter portion circuit (for FL signals only).

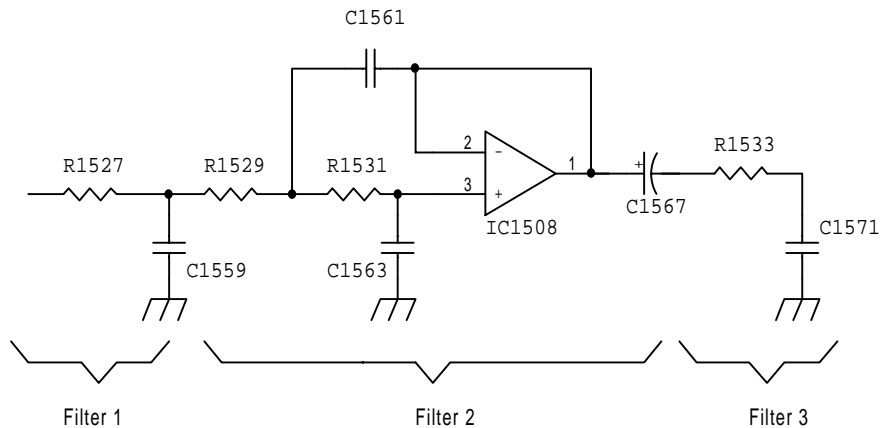

This 3-section filter constitutes a low pass filter of overall cutoff frequency of 44KHz. Audio signals after low pass filter is amplified by IC1510 by about 6dB and output to audio out1 and audio out2. Here, among audio signals, FL signals are input at pin 3 of IC1508 and output from pin 1, then input to pin 2 of IC1510 then output from pin 1. FR signals are input at pin 5 of IC1508 and output from pin 7, then input to pin 6 of IC1510 then output from pin 7.

3. MUTE CIRCUIT (DEC substrate, RJK substrate)

The principal role of mute circuit is the erasing of useless noises occurring when power is turned on. Mute signal for noise erasing is generated by SH MICOM, reverse-amplified by Q1505 and Q1506. Then by putting Q1310 and Q1311 'ON', it mutes audio signals.

In addition, if IC1502 detects no-signal, it generate a mute signal called ZERO MUTE. This latter is reverse-amplified by Q1507 and mutes useless audio signals by putting Q1310 and Q1311 'ON'.

AUDIO CIRCUIT

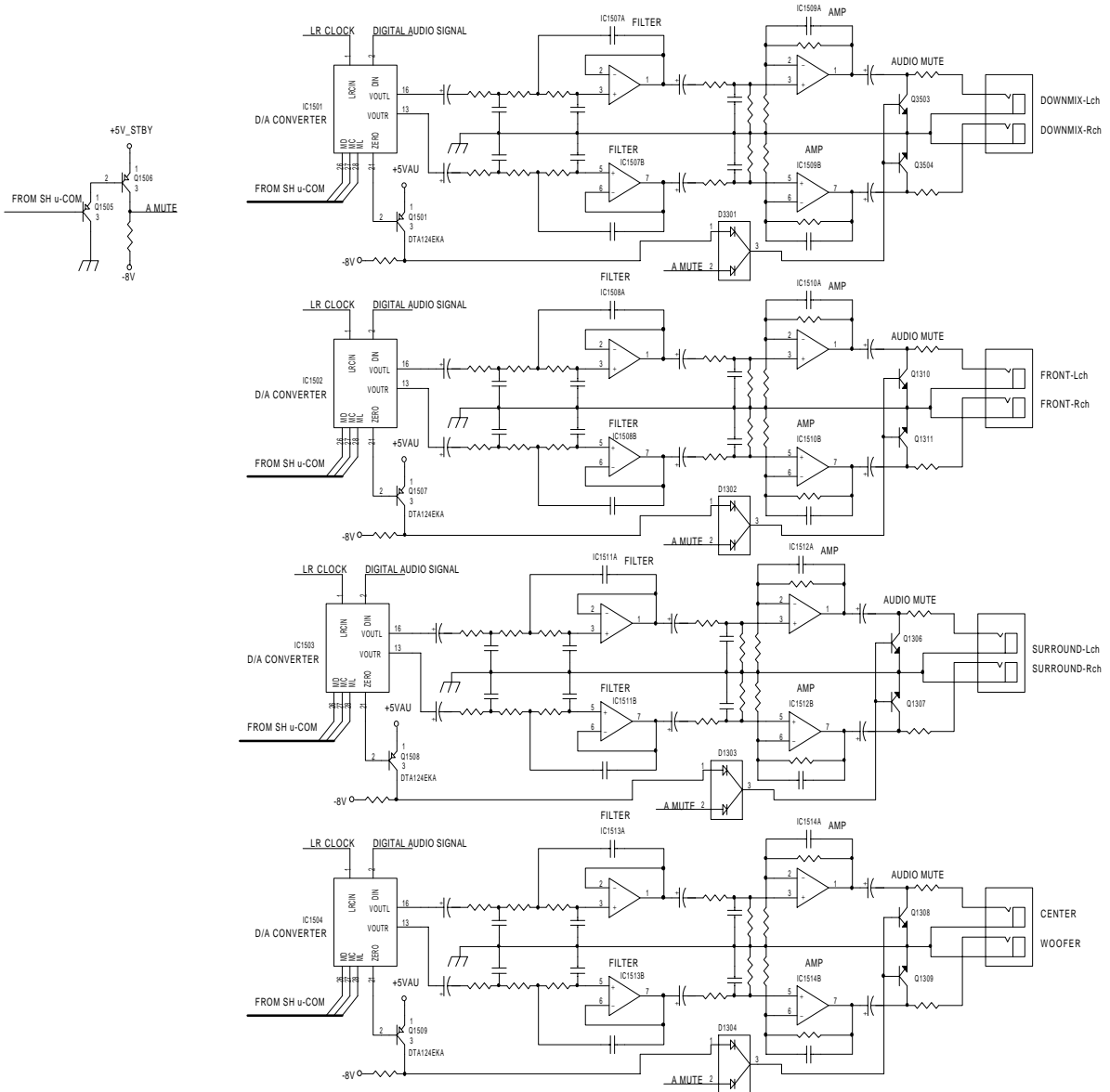

4. 5.1CH Difference List

Output	D/A Converter	Operational amplifier
Downmix L/R	IC 1501	IC 1507, IC 1509
Front L/R	IC 1502	IC 1508, IC 1510
Surround L/R	IC 1503	IC 1511, IC 1512
Center/Woofers	IC 1504	IC 1513, IC 1514

KARAOKE CIRCUIT

(Only available at DVD-5500/DVD-5300 models)

When mic is connected to the mic input terminal, "KARAOKE" will be lighted on FL tube and mode will be changed to Karaoke mode. Therefore, karaoke functions of keycon and vocal cancel may be used. When mic is disconnected, karaoke mode is 'OFF'.

Signals output from MIC1 are input to IC2401 at pin 5, then pass through MIC amplifier, and output to MIC volume RV1762 from pin 7. Afterwards it will be input again to IC2404 at pin 8, then pass through IC2404 internal signal analog/digital converter and output to IC1201 pin 171 from IC2404 pin 1. Similarly signals output from MIC2 are input to IC2401 pin 3, then pass through MIC amplifier and output from pin 1 to MIC volume RV1763. Then input again to IC2404 pin 5, then pass through IC2404 internal signal analog/digital converter and output to IC1201 pin 171 from IC2404 pin 1, then to MIC1/MIC2 serial data (through IC1201 internal echo/MIC G.ETC signal process) and disc audio L/R signal (through path shift/vocal partnering/audio G.edc signal process) mix, serial signal output to audio common circuit IC1501 pin 2 and IC1502 pin 2 from IC1201 pin 161 and IC1201 pin 163.

EXPLANATION:

1. MCLK(IC2404 4 pin): external clock input, from IC1201 pin 169 through buffer IC1505 to IC2404 pin 4.
DVD: $384 * fs = 384 * 48k = 18.432MHz$
CD/VCD: $384 * fs = 384 * 44.1k = 16.934MHz$
2. SCLK(IC2404 2 pin): MIC audio bit clock, from IC1201 pin 173 to IC2404 pin 2.
DVD: $18.432/8 = 2.304MHz$
CD/VCD: $16.934/8 = 2.1168MHz$
3. LRCK(IC2404 3 pin): MIC1 and MIC2 L/Rclock, from IC1201 pin 172 to IC2404 pin 3.
DVD: 48KHz
CD/VCD: 44.1KHz

KARAOKE CIRCUIT

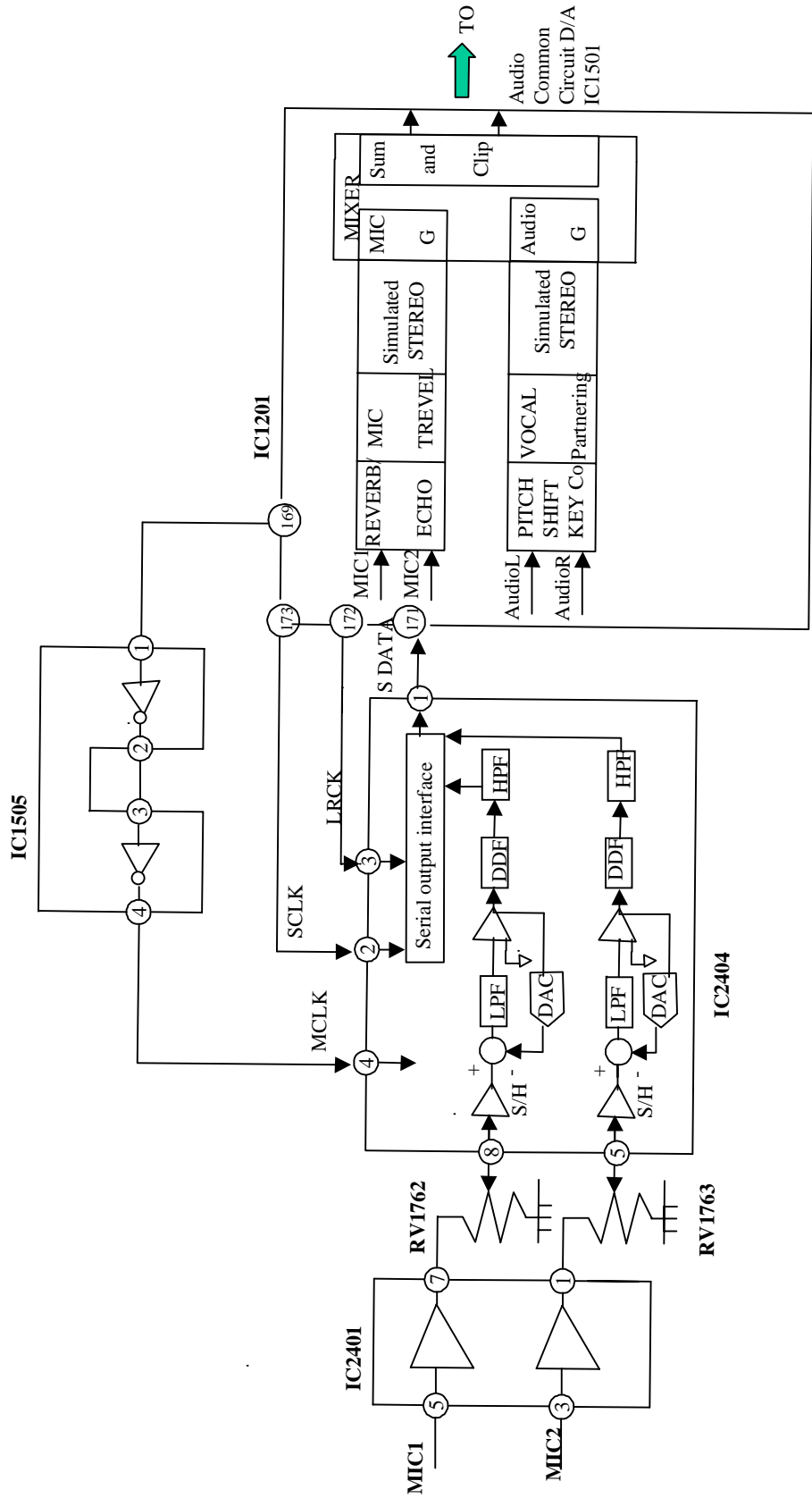

FRONT (FSW) SUBSTRATE CIRCUIT

1. FL MICOM (IC1701)
It performs communications with SH MICOM (pins 6, 7, 10 ~ 13, 15, 25), including the main frame key and remote control operation, FL tube (IC1702) drive, and lighting of power indicator. In addition, it works also in standby mode. When power is 'ON', it outputs control signal at pin 33 to start all power sources and voltages and unlock short circuit toward GND of SH MICOM reset IC (IC1605) output.
2. INCLUSION OF MAIN FRAME KEY AND REMOTE CONTROL OPERATION
Input is done to FL MICOM at pins 2~4 for operation of S1701 ~ S1715 and S1761 ~ S1763 of mainframe key. Input is done to FL MICOM at pins 23, 24, 37~40 for jog shuttle sw (S1718) operation. Remote control signal is received by ultra-red receiver element (IC1703), output at pin 1 and input to FL MICOM at pin 26.
3. FL TUBE DRIVE
Grid voltage of FL TUBE at pins 33~38 is controlled from FL MICOM at pins 41~46; anode voltage of FL TUBE at pins 5~23 from FL MICOM pins 51~69. Among which FL MICOM pins 65~69 are connected to a 20V by R1743~R1747 because no pull down resistance is built-in in IC.
Filament voltage (AC4.2V) is supplied from power source to FL TUBE at pins 1, 2, 41, and 42.
4. POWER INDICATOR
Control signal output from FL MICOM pins 34 and 35 then puts LED driving transistors Q1703 and Q1704 'ON' or 'OFF' then lights 2-color LED (LED1761) green or red. When power is 'ON', Q1704 is 'ON' and the green LED lights up; when standby, Q1703 is 'ON' and the red LED lights up.

POWER SUPPLY CIRCUIT

1. ESSENTIAL OF POWER SUPPLY CIRCUIT OPERATION
Power supply is RCC switching type. Energy is stored in transformer T1, when FETQ1 is 'ON', by AC100V impressed at AC inlet. After that, when FETQ1 turns 'OFF', the energy is released to the secondary side power supply. To diverse circuits from secondary side includes SW (S5V, S3.3V, S12V) that are put 'ON' by FL MICOM control signal (P. ON/OFF) of PG1901 pin 1 and permanently 'ON' supplies (A5V, MUTE A5V, AC4.2V, A-20V, A8V, A-8V).
Detection of secondary side voltage is by A5V. D8, C16, and C17 compose its secondary side commutating circuit. It is fed back by photo-coupler PHC1 to primary side and maintains stable output voltage and is supplied to FL MICOM and ultra-red reception element.
MUTE A5V is for AUDIO MUTE and supplied from A5V output.
S5V output is from A5V output and by intermediary of output control circuit Q3.
S3.3V is output from S5V at 3-terminal regulator IC2.
D11 and C24 compose secondary commutating circuit of S12 that is output by 3-terminal regulator IC3 and is for DVD-ROM drive use.
D11 and C24 compose secondary commutating circuits of A8V that is output by 3-terminal regulator IC4.
For audio circuit proper +5V power supply, AUD S5V is produced from A8V in 5V regulator IC1506 (in DEC substrate).
D13 and C29 compose secondary commutating circuit of A-8V and it output -8V by transistor Q7 and zener diode D20.
A-20V is negative power supply to FL tube. D14 and C33 compose its secondary commutating circuit and output -20V by transistor Q6 and zener diode D17.
AC4.2V is for FL tube heater. To prevent fluctuation of output voltage due to that of power source, a self-exciting push-pull circuit is used. It is input from A5V, passes DC/AC inverter composed of transistors Q8, Q9 and transformer T2 and output. It supplies stable voltage without being disturbed by power source fluctuations. It plays an important role in FL tube life maintenance and against brightness decrease.
2. OPERATION OF PROTECTION CIRCUIT
Protection circuits are different according to different power supplies.
For A5V and S5V, when load current increases and exceeds the control limit of the primary side of the regulator, the over current protection circuit of the primary side operates and regulator output will decrease suddenly. At the same time other outputs stop.
For S12V, S3.3V, and A8V, when load current increases and exceeds the control limit of 3-terminal regulator, the internal over current protection circuit operates and output will suddenly decrease.

Pulling the plug from the wall socket eliminates a short circuit and plugging in again restores the normal state. When A-8V or A-20V output is short circuited, fuse F2 will open to protect circuit. When AC4.2V output is short circuited, fuse F3 will open to protect the circuit. When this and A5V are short circuited, fuse resistance R26 and R27 will open to protect the circuit.

For over current protection for A5V, destruction of zener diode by short will stop the output. The circuit is protected in this way.

By pulling off plug from wall socket, eliminating short circuit, replace destroyed parts, and plug in again, the normal state will be restored in its secondary commutate.

CLOCK CIRCUITS

27MHz X'TAL (X2203)

Block diagram for 27 MHz clock circuit is shown in Fig. 5-8-1.

When power is supplied to 27 MHz X'TAL, it generates 27MHz clock and input it to A/V decoder (IC1201), video encoder (IC2202).

1. A/V DECODER

The A/V decoder is used as CLOCK VCK (input at pins 177 and 178) of video interface signal and output digital video stream synchronized to VCK from 8bit video data bus VDATA[7:0] (output at pins 142, 143, 145, 148, 150, 152, 154, 155)

2. VIDEO ENCODER

At video encoder it is used as system clock CLK (input at pin 48) and output horizontal synchronous $\overline{\text{HSYNC}}$ (output at pin 14) and vertical synchronous $\overline{\text{VSYNC}}$ (output at pin 15) to A/V decoder.

3. Audio DA Converter

The audio external frequency clock signal DA-XCK is used as system clock. DA-XCK is supplied from A/V decoder (output at pin 129), through IC1505 (input at pin 1 and output at pin 4), then pass to Audio DAC (input at IC1501~IC1504 pin 5).

IC1201: The DA-XCK is used to generates Audio bit clock DA-BCK (output at pin 167) and LR clock DA-LRCK (output at pin 166).

DA-XCK	Is interior clock used for generating DA-BCK and DA-LRCK. DA-XCK takes frequency 384 times the sampling frequency.
DA-BCK	Is Audio bit clock obtained by dividing DA-XCK in 8 equal parts. It takes frequency 48 times that of sampling.
DA-LRCK	Is clock that identifies channel (Lch or Rch) against all Audio sampling.

* The Audio Interface Unit inside A/V decoder corresponds to sampling frequencies (fs) 44.1kHz (CD-DA, Video-CD), 48kHz, 96kHz (DVD).

The frequency of DA-BCK is defined by Formula 1:

$$f \text{ DA-BCK} = \text{Audio data bit length} * 2 * fs \dots\dots\dots 1$$

At A/V decoder, interior DA-XCK is divided into 8 equal parts and output as DA-BCK (Formula 2)

$$f \text{ DA-BCK} = f \text{ DA-XCK} / 8 \dots\dots\dots 2$$

Therefore, DA-XCX frequency takes the value 384fs according to formulas 1 and 2. Audio data bit length is fixed 24bit. (Formula 3)

$$f \text{ DA-XCX} = \text{Audio data bit length} * 2 * fs * 8 = 24 * 2 * fs * 8 = 384 fs \dots\dots\dots 3$$

According to Formulas 2 and 3, A/V decoder drives DA-BCK

with frequency 48 times of sampling frequency. (Formula 4)

$$f \text{ DA-BCK} = 384fs / 8 = 48fs \dots\dots\dots 4$$

The relationships between Audio interface signals (DA-XCK, DA-LRCK, DA-BCK) and each sampling frequency are as follows:

- ❑ Sampling frequency: 44.1 kHz (For CD-DA and Video-CD)
DA-XCK $384 \cdot fs = 16.934\text{MHz}$
DA-BCK $DA\text{-XCK}/8 = 2.1168\text{MHz}$
DA-LRCK $DA\text{-BCK}/48 = 44.1\text{kHz} = fs$

- ❑ Sampling frequency: 48kHz (for DVD)
DA-XCK $384 \cdot fs = 18.432\text{MHz}$
DA-BCK $DA\text{-XCK}/8 = 2.304\text{MHz}$
DA-LRCK $DA\text{-BCK}/48 = 48\text{kHz} = fs$

- ❑ Sampling frequency: 96kHz (for DVD)
DA-XCK $384 \cdot fs = 36.864\text{MHz}$
DA-BCK $DA\text{-XCK}/8 = 4.608\text{MHz}$
DA-LRCK $DA\text{-BCK}/48 = 96\text{kHz} = fs$

20MHz X'TAL (X1601)

20MHz clock is generated by attaching 20MHz crystal trembler to SH μ -COM (IC1601) and used as the system clock of SH μ -COM. This system clock is supplied to I/F GATE ARRAY (input at IC1101 39 pin) and used as clock.

BLOCK DIAGRAM OF 27MHz CLOCK CIRCUITS

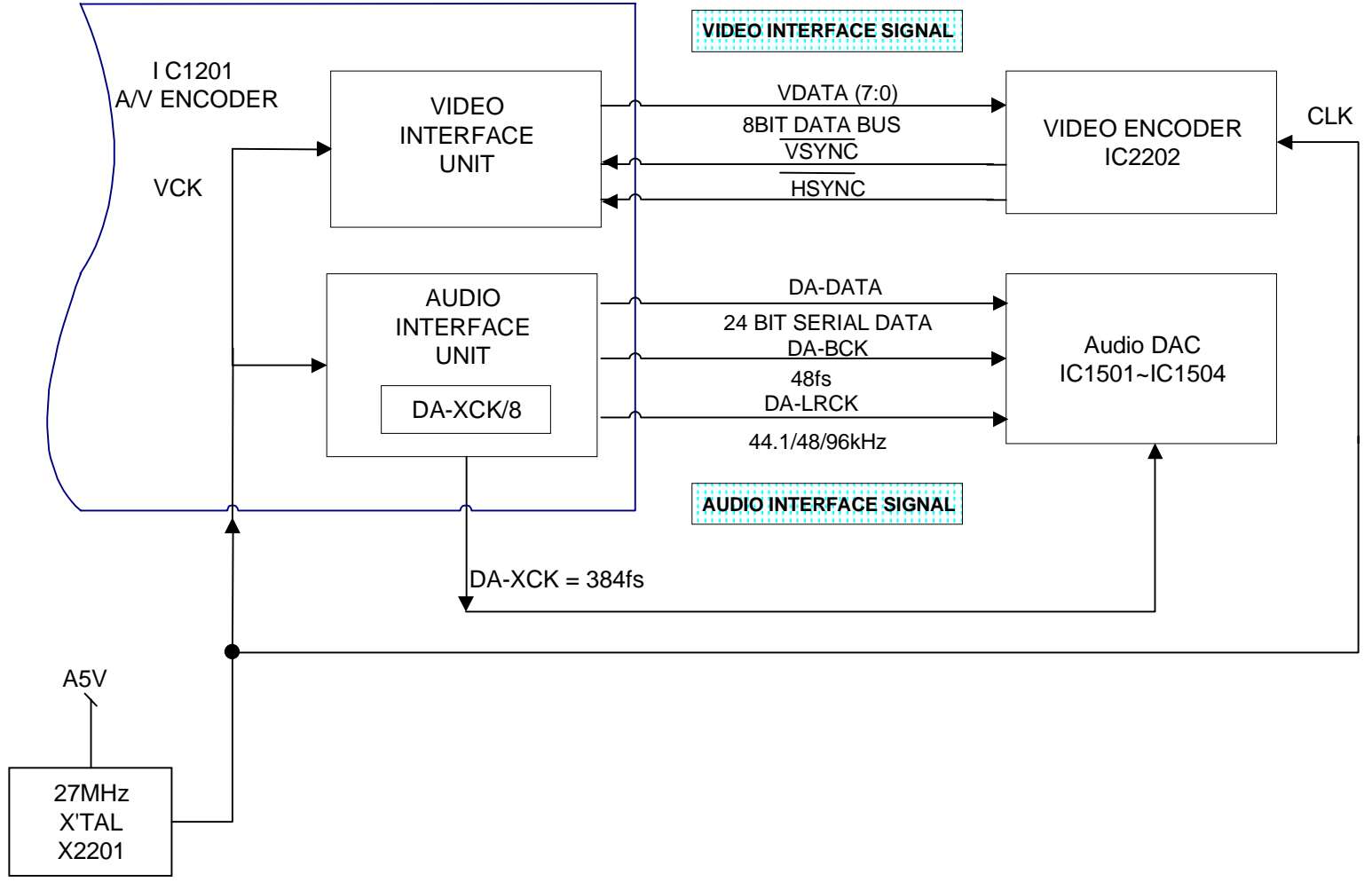

Troubleshooting

VIDEO CIRCUIT

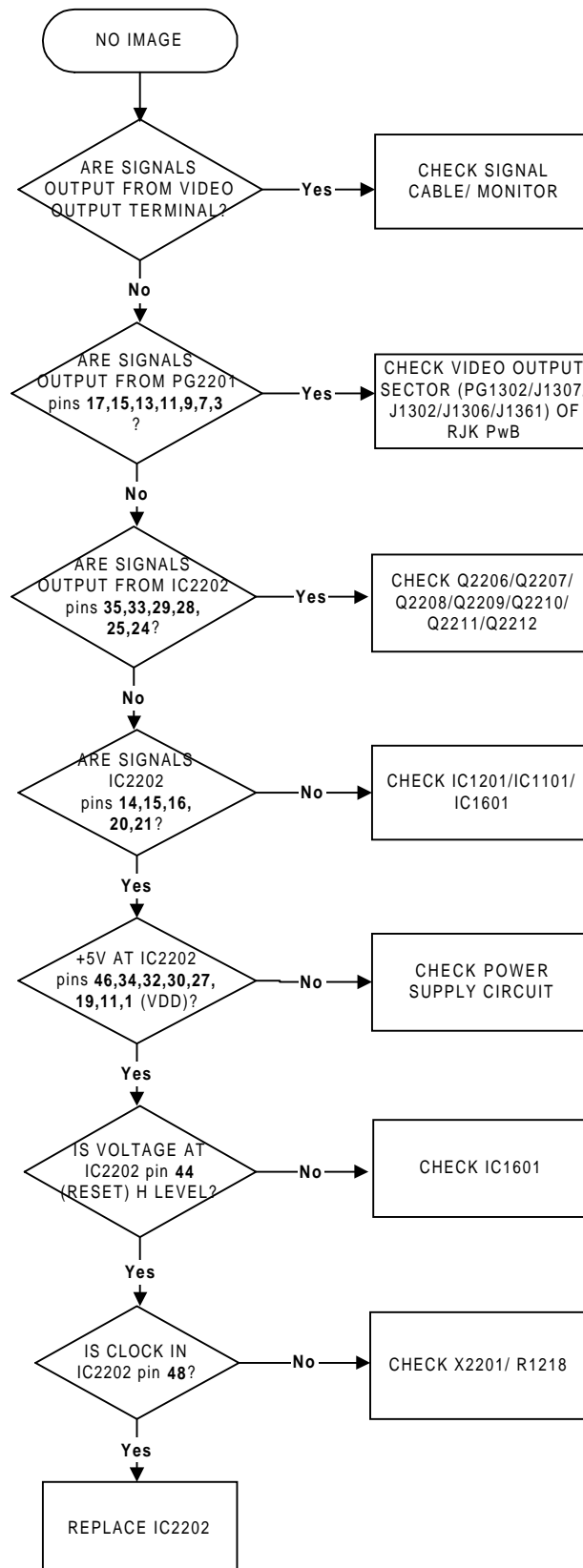

AUDIO CIRCUIT

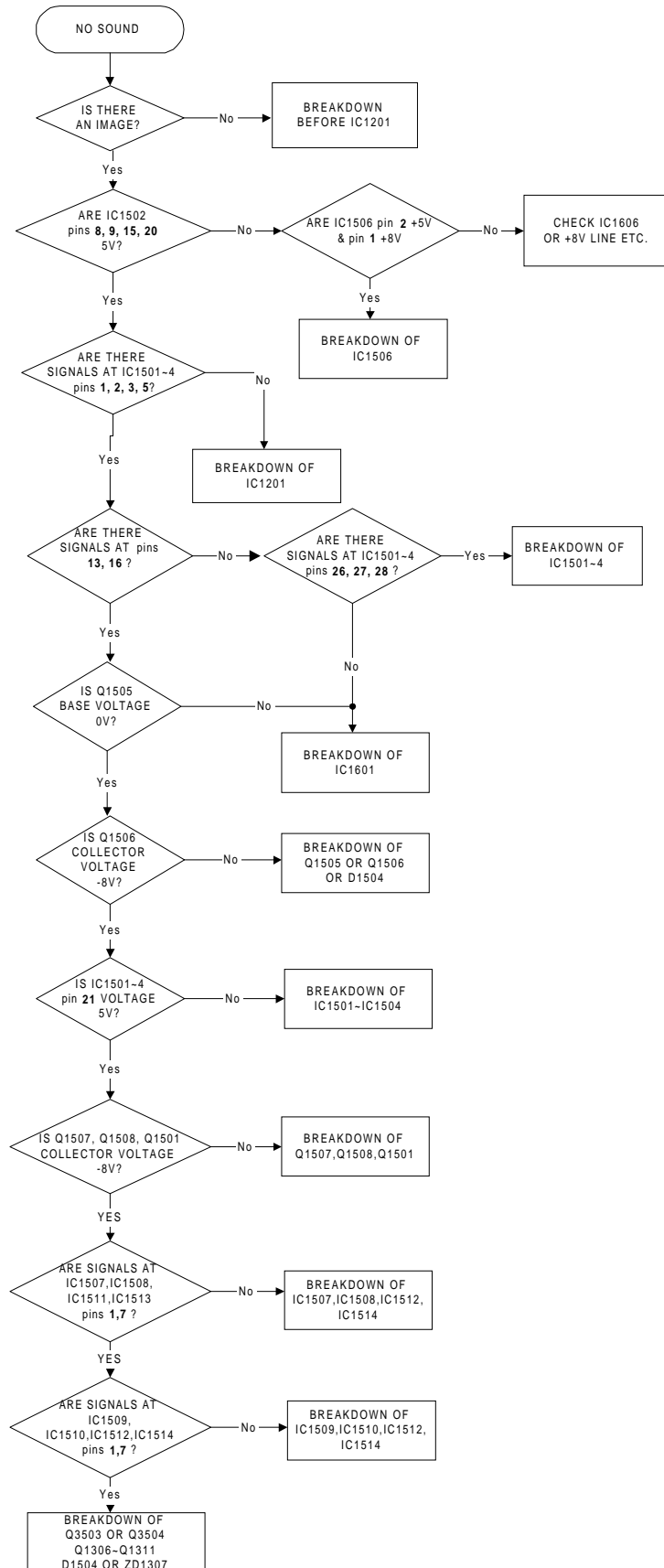

KARAOKE CIRCUIT

(Only available at DVD-5500/DVD-5300 models)

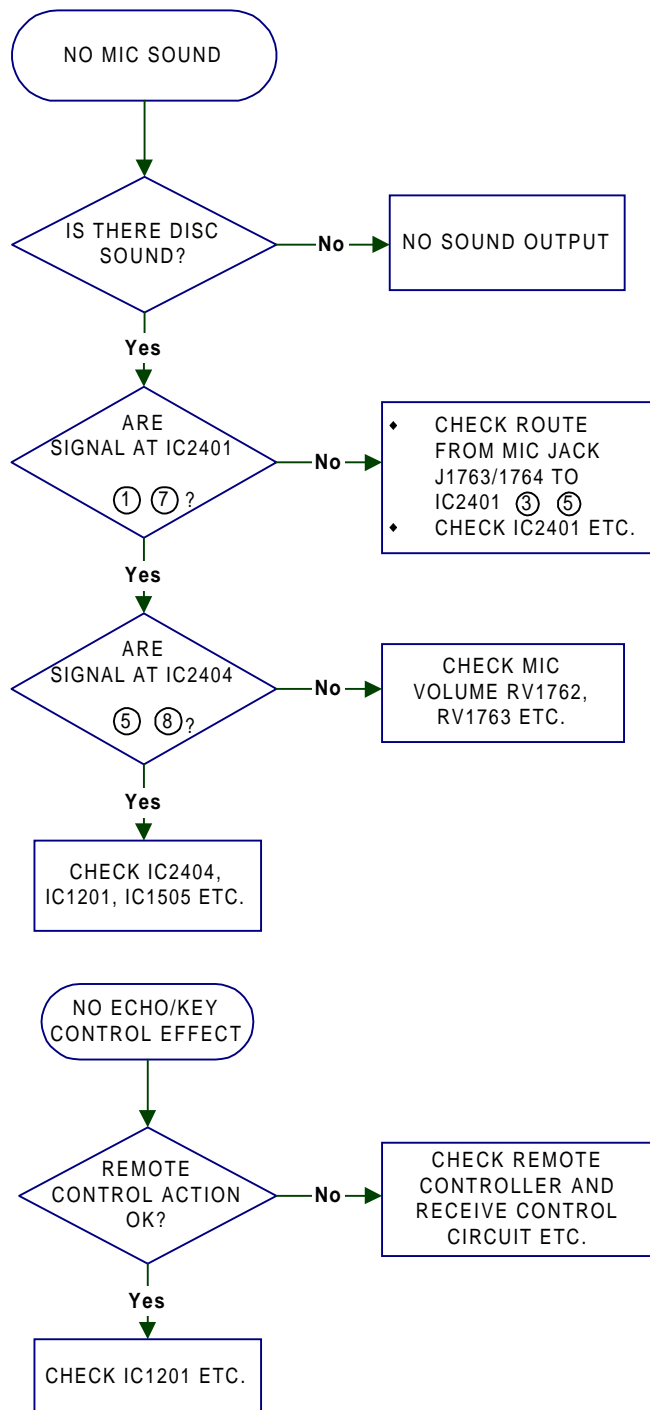

About System Reset Function

The player can not work normally with non-standard discs. If you encounter the abnormal status , please press **STOP** button once to stop it. If it can't stop normally, please press **POWER/STANDBY** button. If the status is not changed in about 20 seconds after pressing POWER/STANDBY button then just press **LAST** button and **ENTER** button concurrently on the front panel to reset the system. After resetting, the system will restart and change into standby mode (The POWER/STANDBY indicator lights in red color). Therefore, please press POWER/STANDBY button again to start the system. (Pull out the power cord and plug it again, the restarted system will also change into standby state.)

System Utility

How to upgrade the system utility

1. Power on the system and press the OPEN/CLOSE button to open the DVD-ROM tray.
2. Place the version-up CD-R disc into the DVD-ROM.
3. The DVD player will read the CD-R disc and upgrade the system utility version, after about 40 seconds, the DVD-ROM tray will open automatically.
4. Take out the version-up CD-R disc.
5. Pull out the power cord then plug it again.
6. Press the POWER/STANDBY button to restart the system, while the DVD-ROM tray closed, the version had been upgarded already.

NOTE: If the version of the system utility in the CD-R disk is older than original one, then the front display window will shows 'No play'.

How to check the system utility version

1. At the power on state, press the **POWER/STANDBY** button and **LAST** button once in the same time and then release the POWER/STANDBY button only and still press the LAST button continually for more than 5 seconds.
2. The front display window will appear the system utility version.

Removal and Replacement

Preliminaries before disassembling machines

This chapter contains step-by-step procedures on how to disassemble the DVD system for maintenance and troubleshooting.

To disassemble the system, you need the following tools:

- Wrist grounding strap and conductive mat for preventing electrostatic discharge
- Phillips screwdriver
- Tweezers

NOTE: The screws for the different components vary in size. During the disassembly process, group the screws with the corresponding components to avoid mismatch when putting back the components.

Before You Begin

Before proceeding with the disassembly procedure, make sure that you do the following:

1. Turn off the power to the system and all peripherals.
2. Unplug the AC adapter and all power and signal cables from the system.

Disassembly Procedure Flowchart

The flowchart on the succeeding page gives you a graphic representation of the entire disassembly sequence and instructs you on the components that need to be removed during servicing. For example, if you want to remove the DVD-ROM drive, you must first remove the top cover, then disassemble the inside assembly frame in that order.

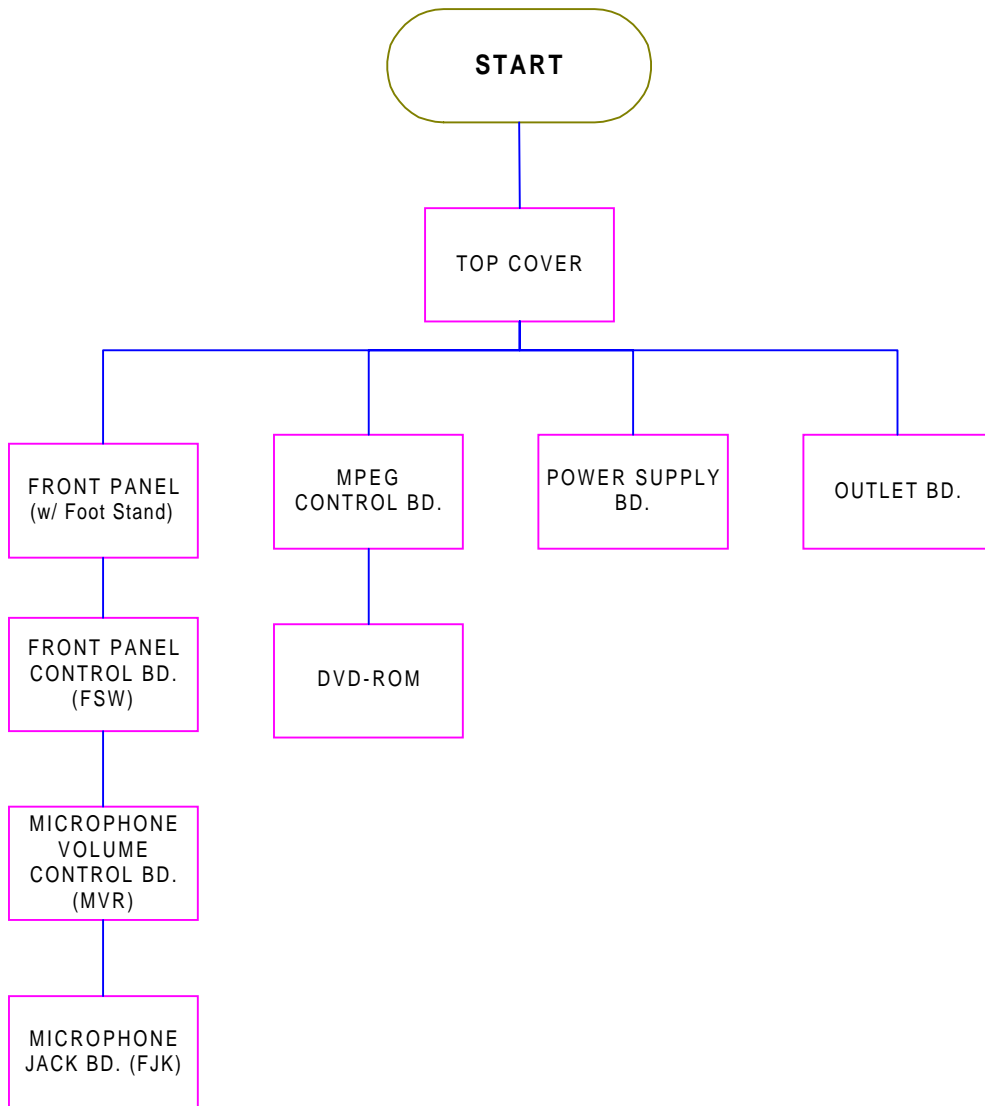

Disassembly Procedures

Removing the Top Cover

1. Remove the two screws from each side of the machine and the three screws from the rear side.



2. Gently pull out the top cover from both sides of the machine.



3. Slide out the top cover lightly until it clicks to let it out from the front panel. Then, lift it up and move away from the machine.

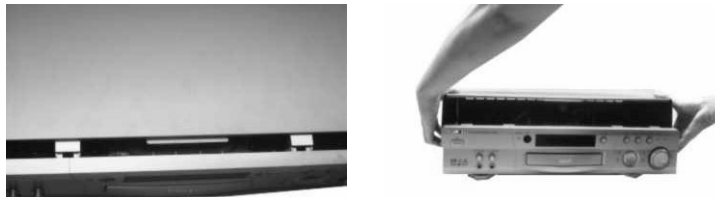

Removing the FootStand

1. Release the screw from the footstand, then remove the footstand..



Removing the Front Panel

1. Disconnect the three cables from the MPEG control board.
2. Disconnect the cable and remove the two screws from the power supply board.

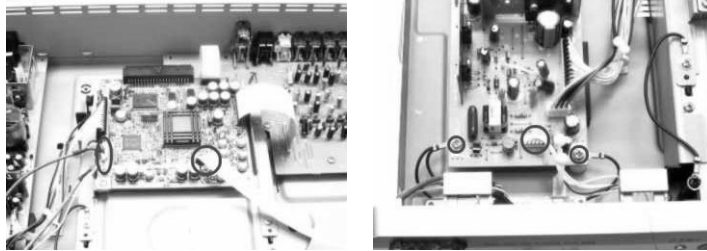

3. Turn the machine over, then remove the screw from the bottom of the front panel.



4. Use a screwdriver into the emergency eject hole to release the screw by clockwise direction from bottom of the machine, and the DVD-ROM tray will eject gently.

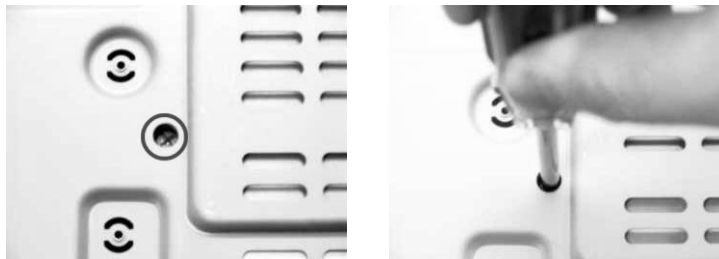

5. Use your finger to slide up the DVD-ROM tray cover, then push the tray inside.



-
6. Detach the latches from both sides of the front panel and the bottom side of the machine.



7. Gently pull out the front panel.

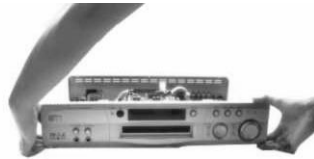

Removing the MPEG Control Board

1. Disconnect the four cables and remove the four screws from the MPEG control board as shown below.
2. Remove the MPEG control board..

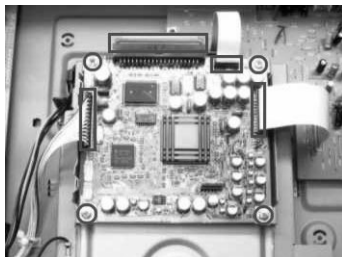

Removing the Power Supply Board

1. Disconnect the two cables and remove the screw from the power supply board.
2. Then, remove the two screws of the power socket on the rear panel of the machine.

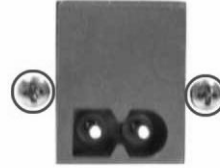
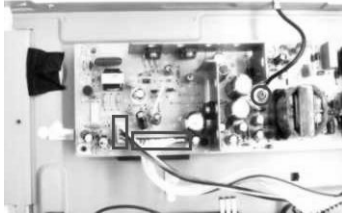

3. Slightly lift up and take away the power supply board.



Removing the DVD-ROM Drive

1. Remove the two screws from each side of the DVD-ROM drive, then remove the DVD-ROM drive.



2. Disconnect the power cable and the IDE cable from the DVD-ROM drive.

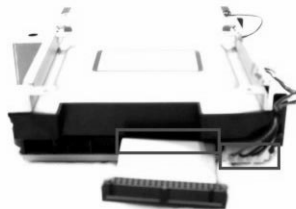

3. To remove the kitting part, remove the four screws from the top of the DVD-ROM drive.



4. Remove the four screws of the DVD-ROM drive to detach the DVD-ROM shield and the two EMI shields from the bottom of the DVD-ROM drive.

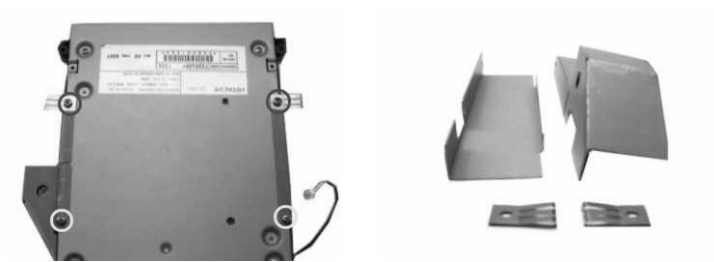

Removing the Outlet Board

1. Disconnect the two cables and remove the four screws from the outlet board.
2. Then, remove the eight screws from the rear panel of the machine.



3. Lift the outlet board away.



Removing the Front Panel Control Boards

1. Remove the eight screws from the front panel control board (FSW board).
2. Remove the seven screws from the microphone volume control board (MVR board).

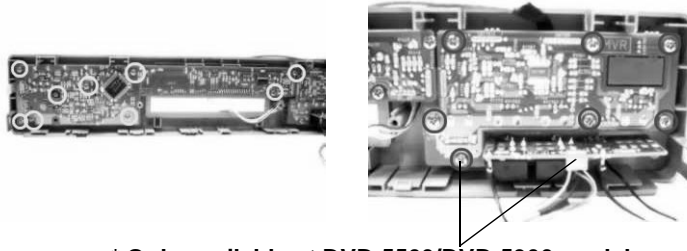

* Only available at DVD-5500/DVD-5300 models.

3. Use your finger to detach the video speed control knob as shown below.

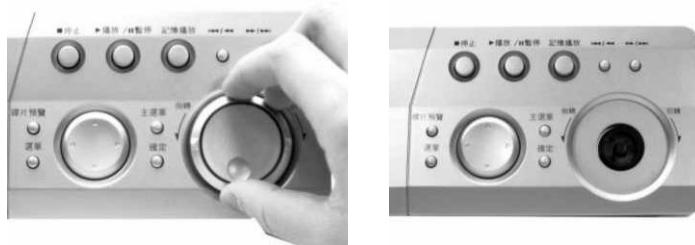

4. Use your finger to detach the cap of the volume adjuster as shown below.



* The Karaoke function is only available at DVD-5500/DVD-5300 models.

-
5. Gently lift up the front panel control boards then separate the two boards by disconnecting the connector in between them.

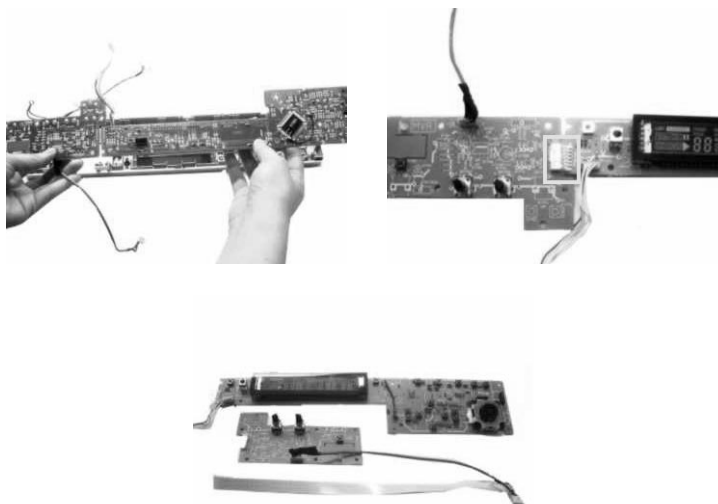

6. Remove the screw from the microphone jack board, then detach the microphone jack board (FJK board)¹.

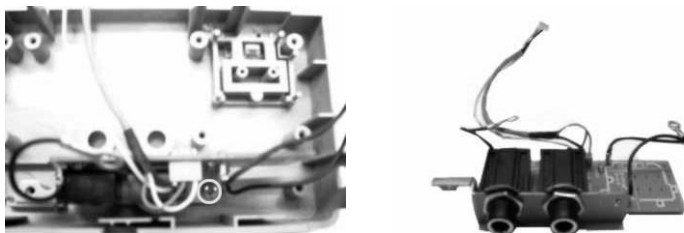

¹ This microphone jack board is for Karaoke function and only available at DVD-5500/DVD-5300 models.

System Block Diagrams

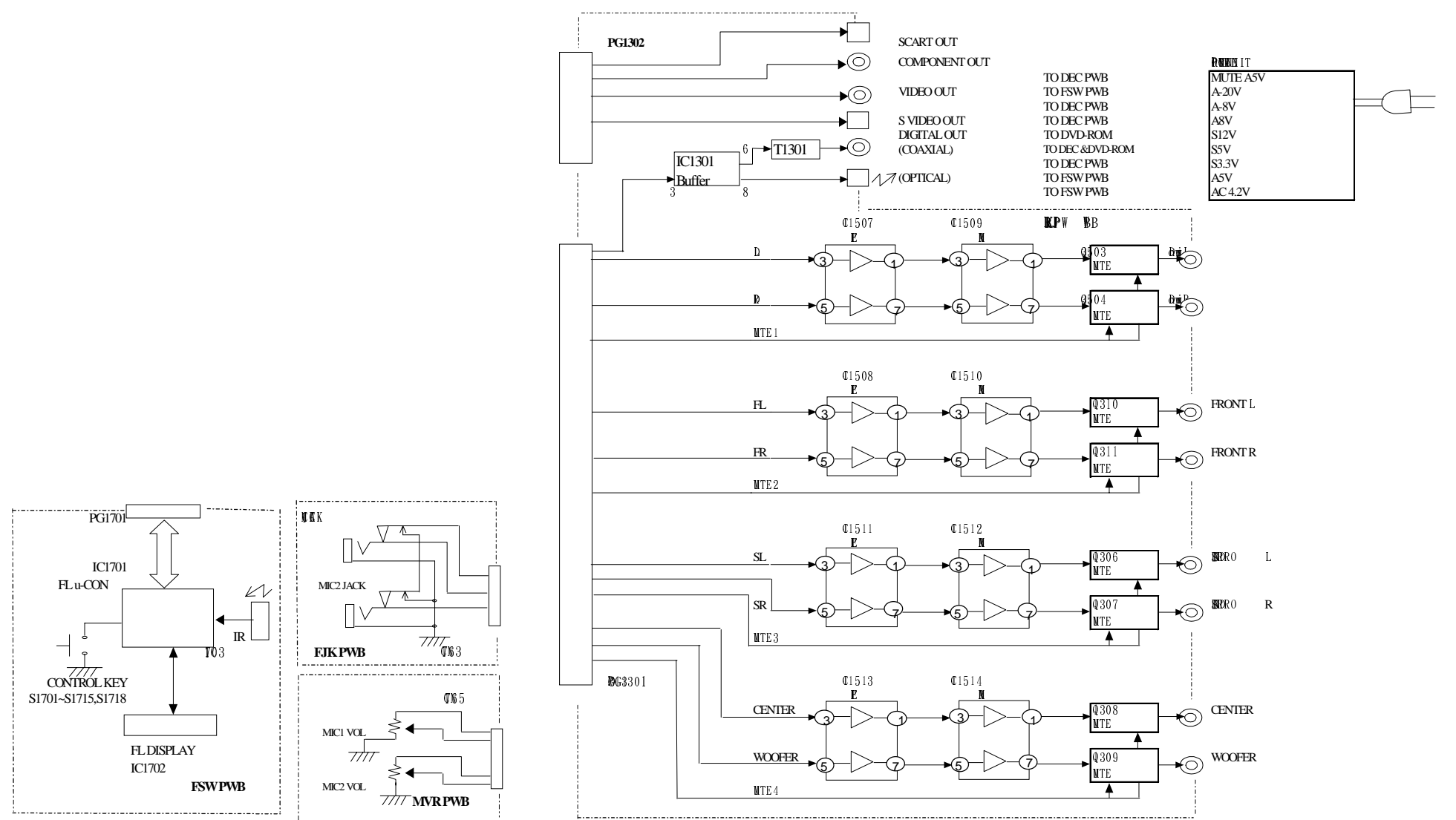
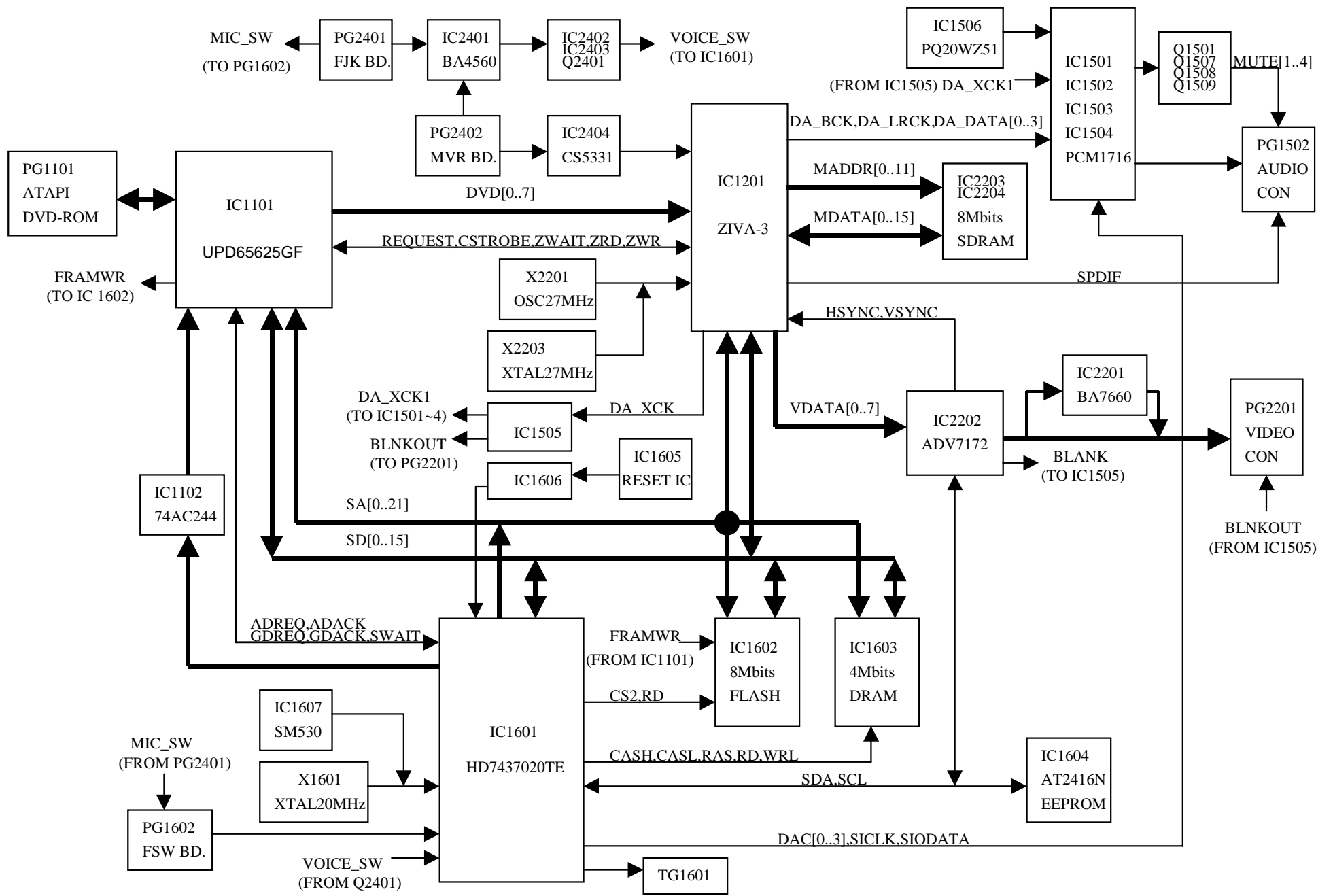

Exploded Diagram

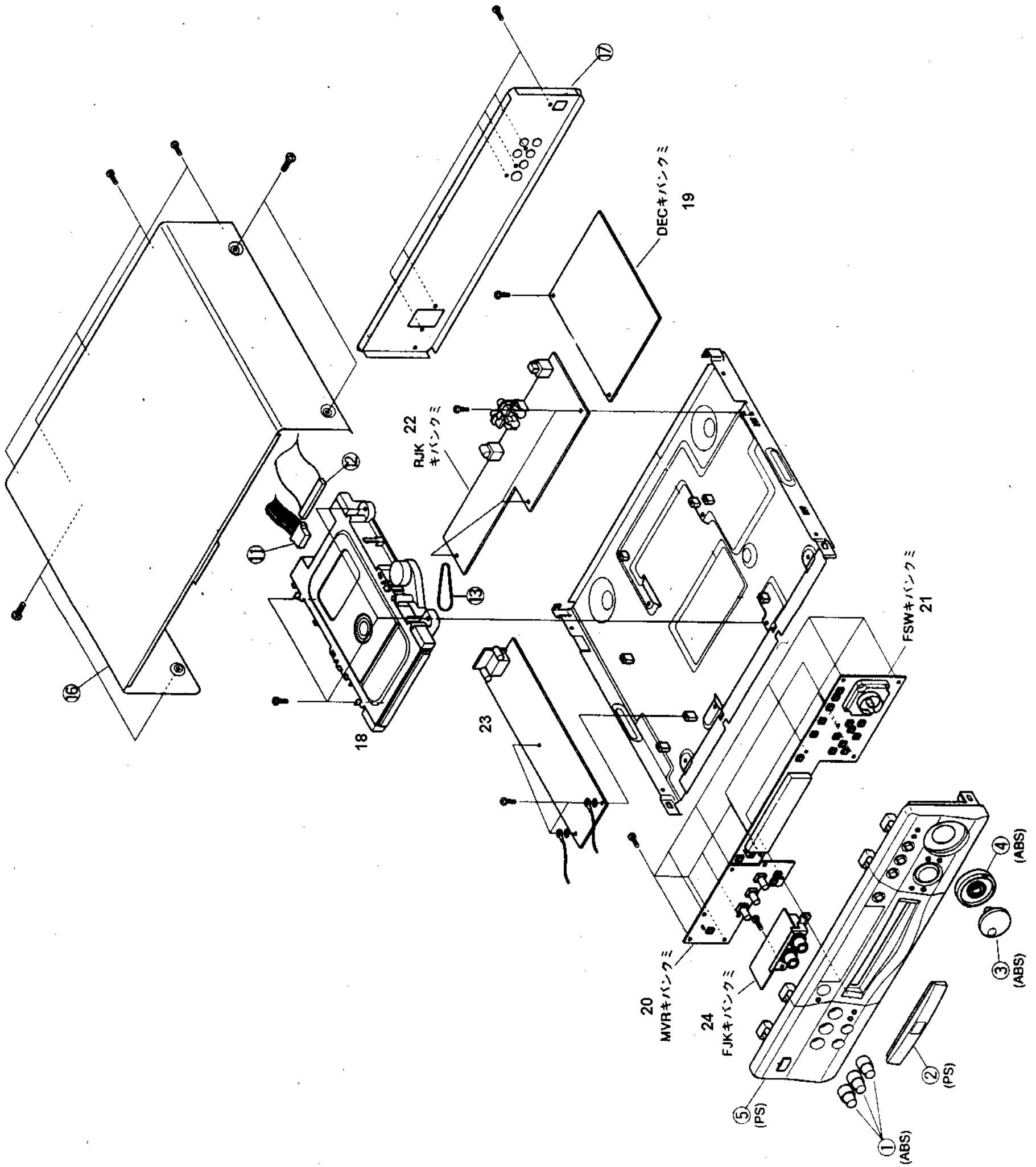

REPLACEMENT PARTS LIST

Note: The model names shown in the parts list are abbreviated as follows.

E:DV-P250E	UK:DV-P250E(UK)	U:DV-P250U	PX:DV-P250U(PX)
M:DV-P250A(M)	S:DV-P250A(S)	AU:DV-P250A(AU)	T:DV-P250A(T)
C:DV-P250C			

SYMBOL			SYMBOL		
NO	P-NO	DESCRIPTION	NO	P-NO	DESCRIPTION
2	PH16681	Panel tray set[E.UK]	20	5002133	MVR PWB Assy[PX]
2	PH16682	Panel tray set[M.S.AU.T.C]	20	5002134	MVR PWB Assy[M.S.AU.T]
2	PH16683	Panel tray set[U.PX]	21	5002111	FSW PWB Assy[E.UK]
3	PC14601	Knob (JOG)[E.UK]	21	5002112	FSW PWB Assy[U]
3	PC14602	Knob (JOG)[U.PX]	21	5002113	FSW PWB Assy[PX]
3	PC14605	Knob (JOG)[M.S.AU.T.C]	21	5002511	FSW PWB Assy[C]
4	PC14612	Knob (SHU)[U.PX]	21	5002114	FSW PWB Assy[M.S.AU.T]
4	PC14616	Knob (SHU)[E.UK]	22	5002121	RJK PWB Assy[E.UK]
4	PC14618	Knob (SHU)[M.S.AU.T.C]	22	5002122	RJK PWB Assy[U]
5	325A961	Panel front set[E.UK]	22	5002123	RJK PWB Assy[PX]
5	325A962	Panel front set[U.PX]	22	5002124	RJK PWB Assy[M.S.AU.T]
5	325A963	Panel front set[M.S.AU.T]	22	5002521	RJK PWB Assy[C]
5	325A964	Panel front set[C]	△ 23	257A181	Power unit[U.T]
11	EF13871	Connector (4PIN)[U.PX.M.S.AU.T.C]	△ 23	257A201	Power unit[E.UK.M.S.AU.C]
11	EF13872	Connector (4PIN)[E.UK]	△ 23	257A211	Power unit[PX]
12	EF13683	Connector (40PIN)		460A622	Instruction Manual[E]
13	KK10323	Rubber belt		460A623	Instruction Manual[E]
16	QA12361	Cover top[E.UK]		460A624	Instruction Manual[UK]
16	QA12362	Cover top[M.S.AU.T.C]		460A625	Instruction Manual[U.PX]
16	QA12363	Cover top[U.PX]		460A626	Instruction Manual[T]
17	335A061	Panel rear set[E.UK]		460A627	Instruction Manual[M.S]
17	335A062	Panel rear set[U.PX]		460A628	Instruction Manual[AU.T]
17	335A063	Panel rear set[T]		460A629	Instruction Manual[U.PX]
17	335A064	Panel rear set[M.S.AU.C]		261A381	Cord (3PIN)
18	UQ20351	ROM DRIVE		237A482	Remote control (DV-RM250)[U.PX.M.S.AU.T]
19	5002141	DEC PWB Assy[E.UK]		237A481	Remote control (DV-RM250E)[E.UK]
19	5002142	DEC PWB Assy[U]		237A489	Remote control[C]
19	5002143	DEC PWB Assy[PX]	△	261A531	Cord AC[AU]
19	5002144	DEC PWB Assy[M.S.AU.T]	△	261A611	Cord AC[S]
19	5002561	DEC PWB Assy[C]	△	261A641	Cord AC[U.PX]
20	5002131	MVR PWB Assy[E.UK]	△	EV00711	Cord AC[T]
20	5002132	MVR PWB Assy[U]	△	EV00731	Cord AC[UK.M]
20	5002531	MVR PWB Assy[C]	△	EV00741	Cord AC[E]
20	5002531	MVR PWB Assy[C]	△	261A841	Cord AC[C]

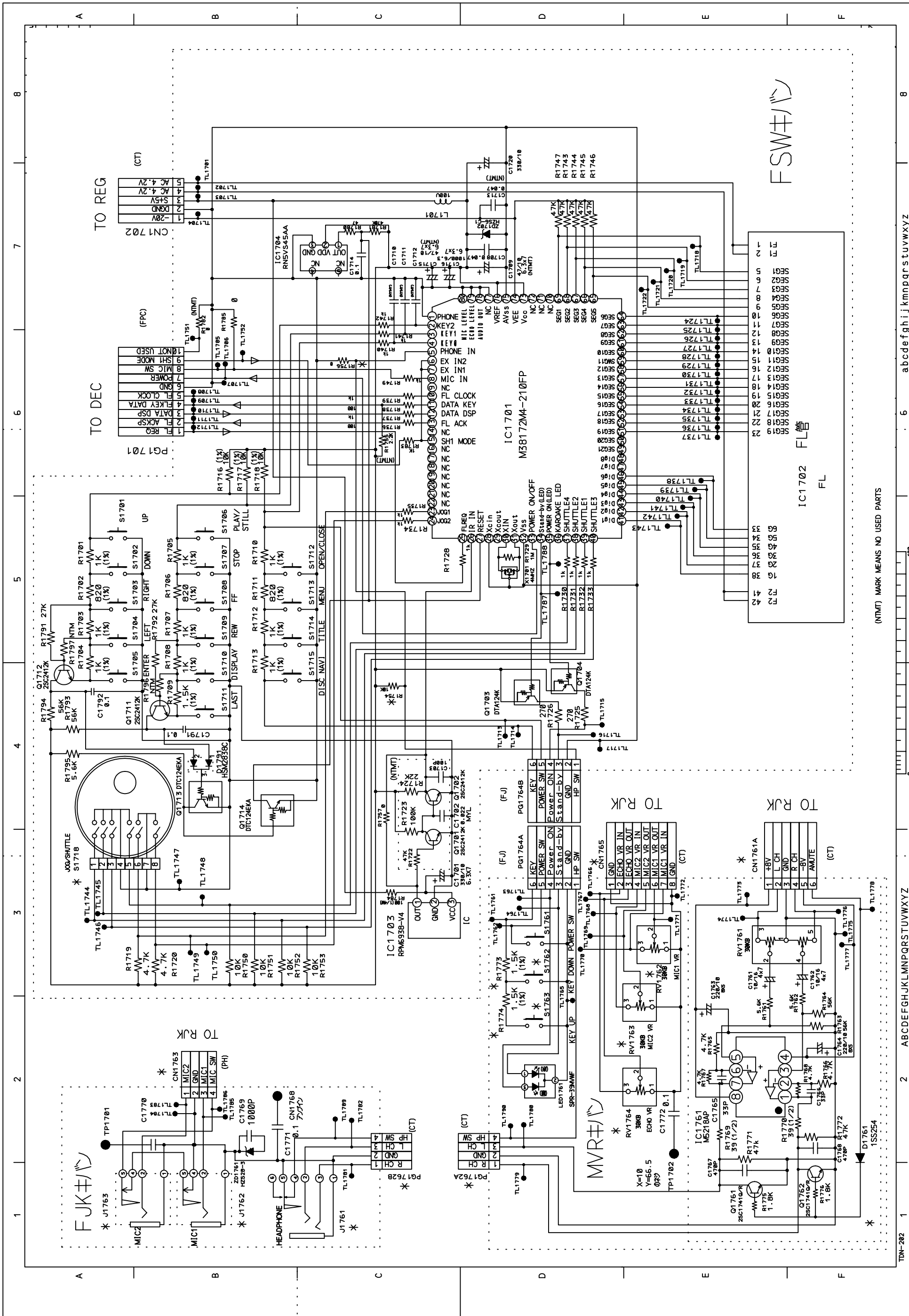

F5W#11

(N/T/M) MARK MEANS NO USED PARTS

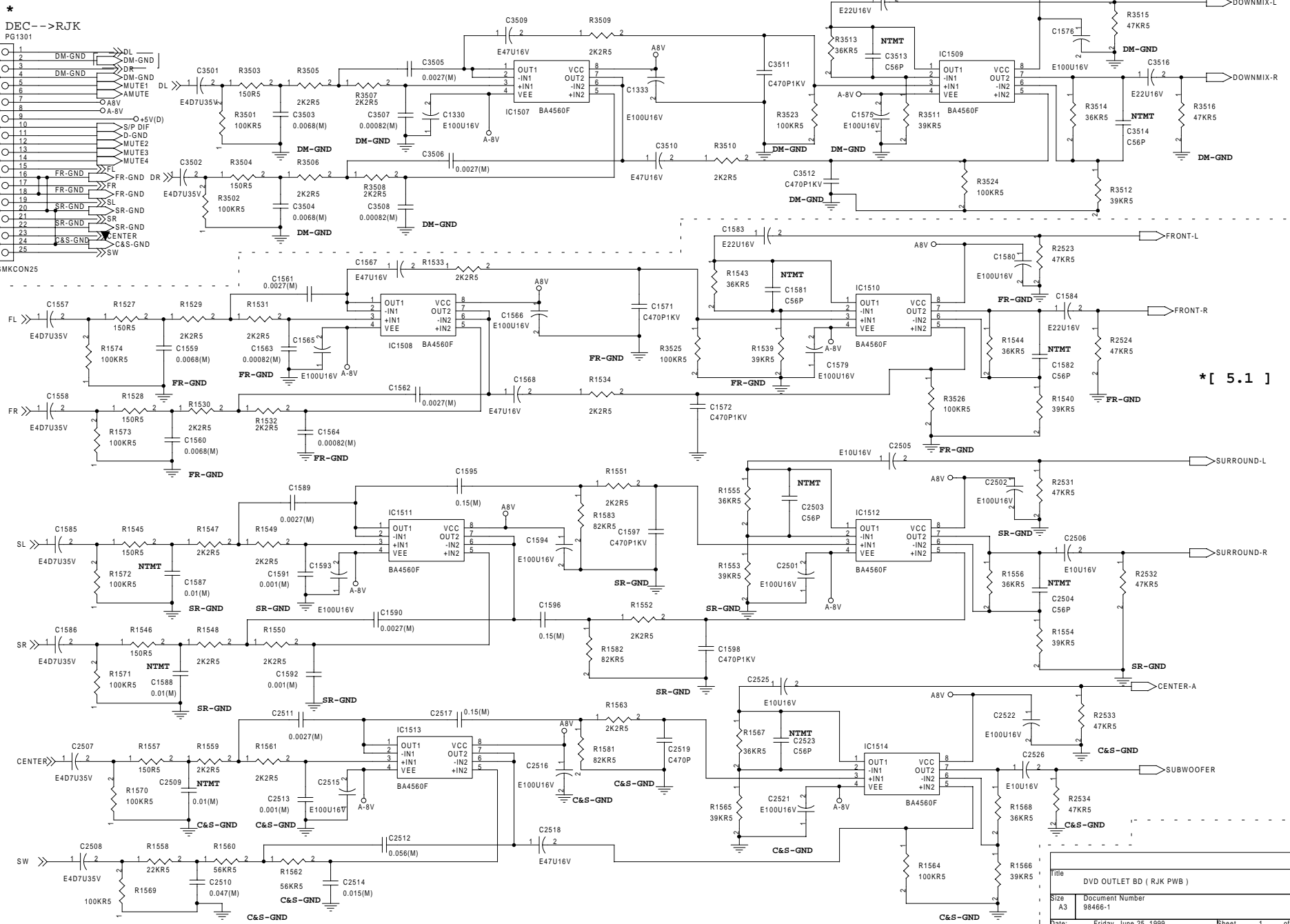

Title			DVD OUTLET BD (RJK PWB)		
Size	Document Number		Rev		
A3	98466-1				
Date	Friday, June 25, 1999	Sheet	1	of	3

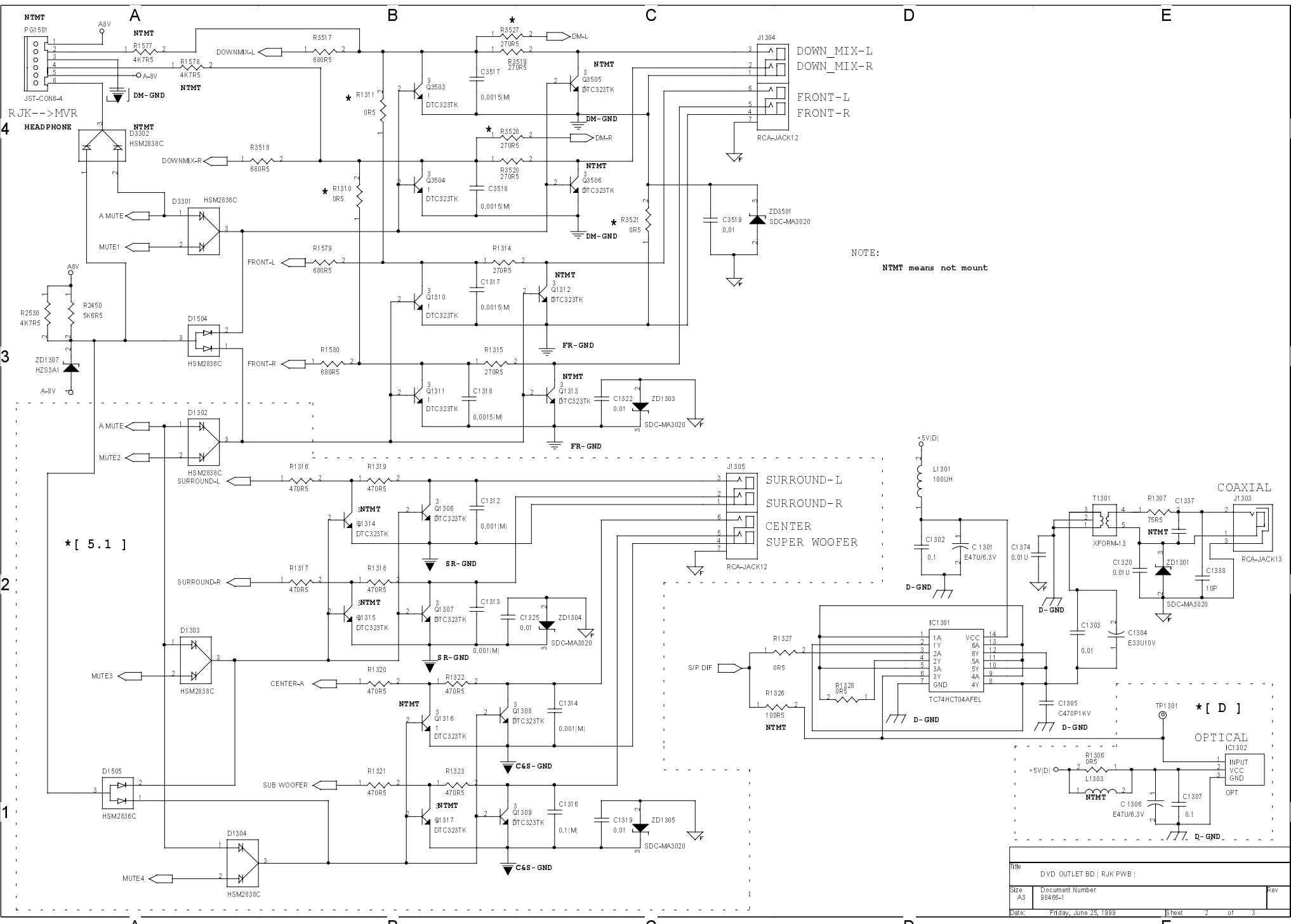

NOTE:
NTMT means not mount

Title D V D O U T L E T B D R J K P W B			
Size A3	Document Number 98465-1	Rev	
Date: Friday, June 25, 1999	Sheet 2	of	3

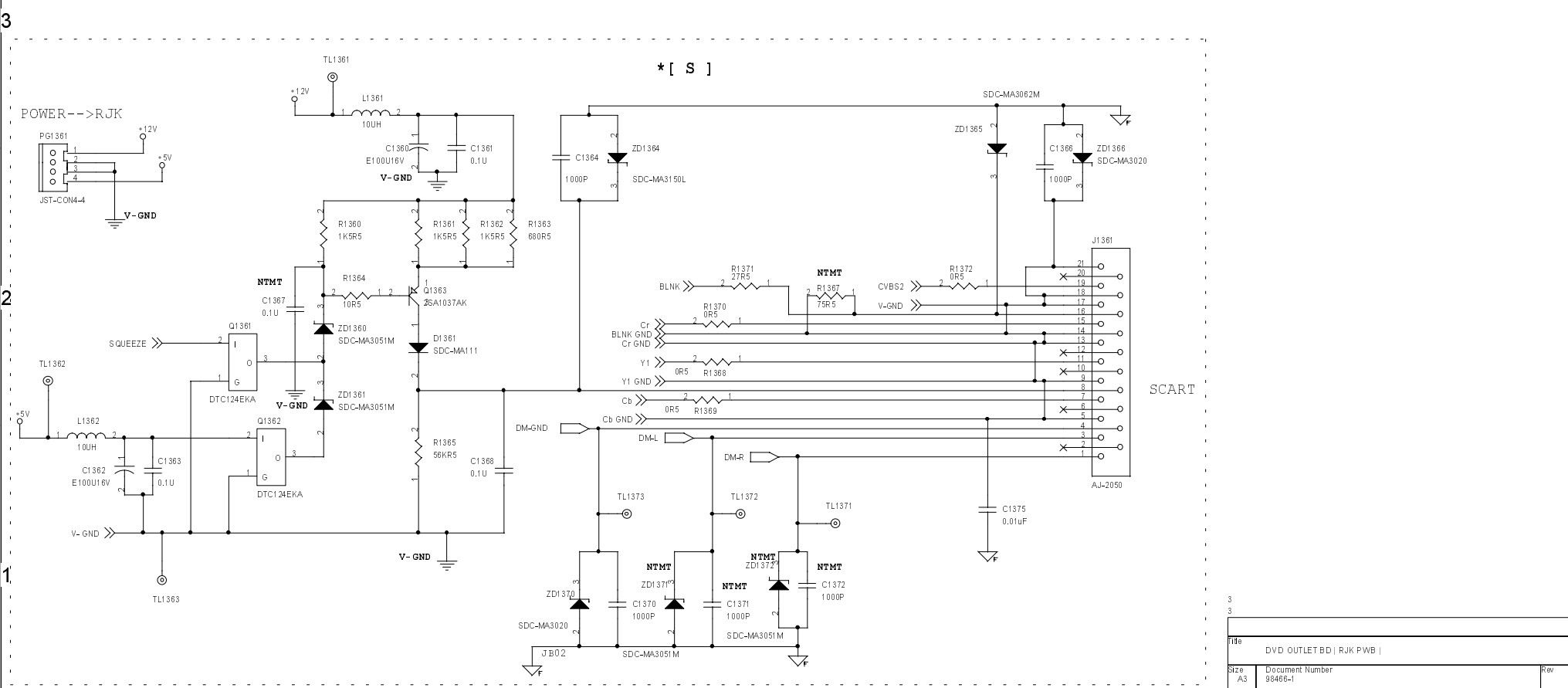
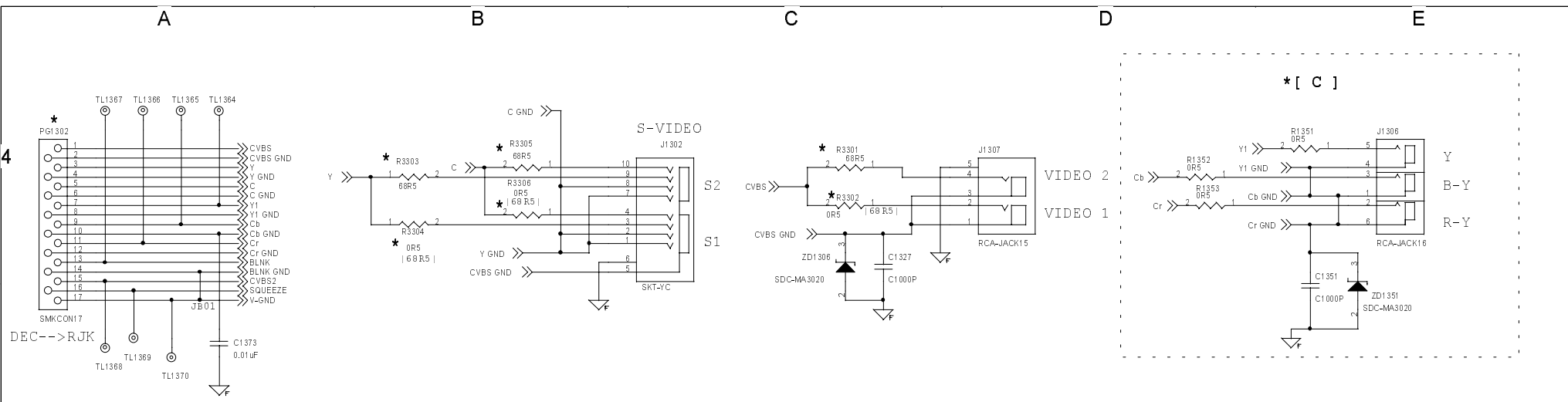

3	DVD OUTLET BD RJK PWB	
3	File	
Size	Document Number	Rev
A3	98466-1	
Date:	Friday, June 25, 1999	Sheet 3 of 3

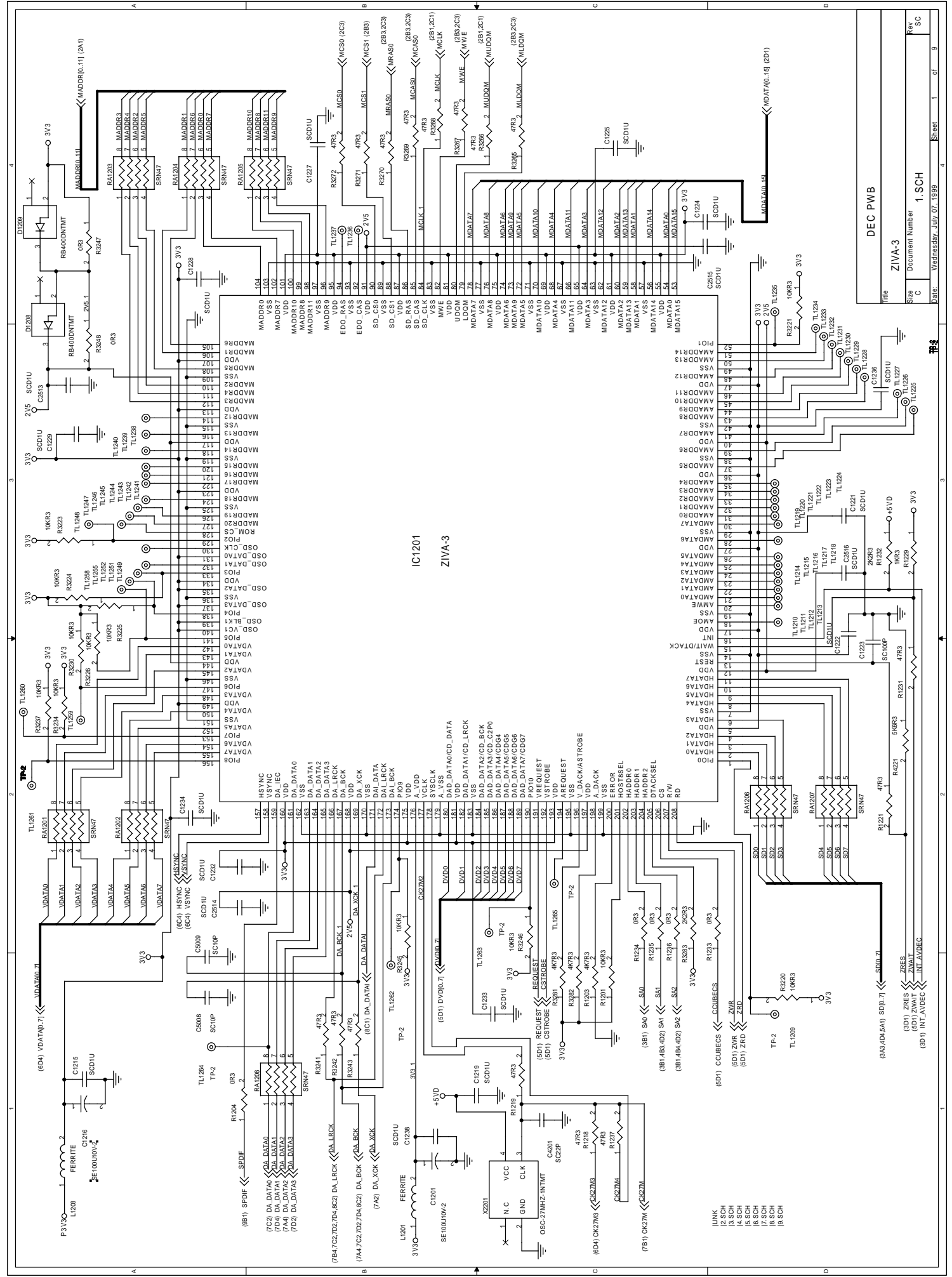

File: ZIVA-3
 Doc: Document Number
 Size: 1 of 9
 Date: Wednesday, July 07, 1999
 Sheet: 1 of 9

Rev
 SC

DEC PWB
 ZIVA-3
 1.SCH

LINK
 12 SCH
 14 SCH
 16 SCH
 18 SCH
 19 SCH

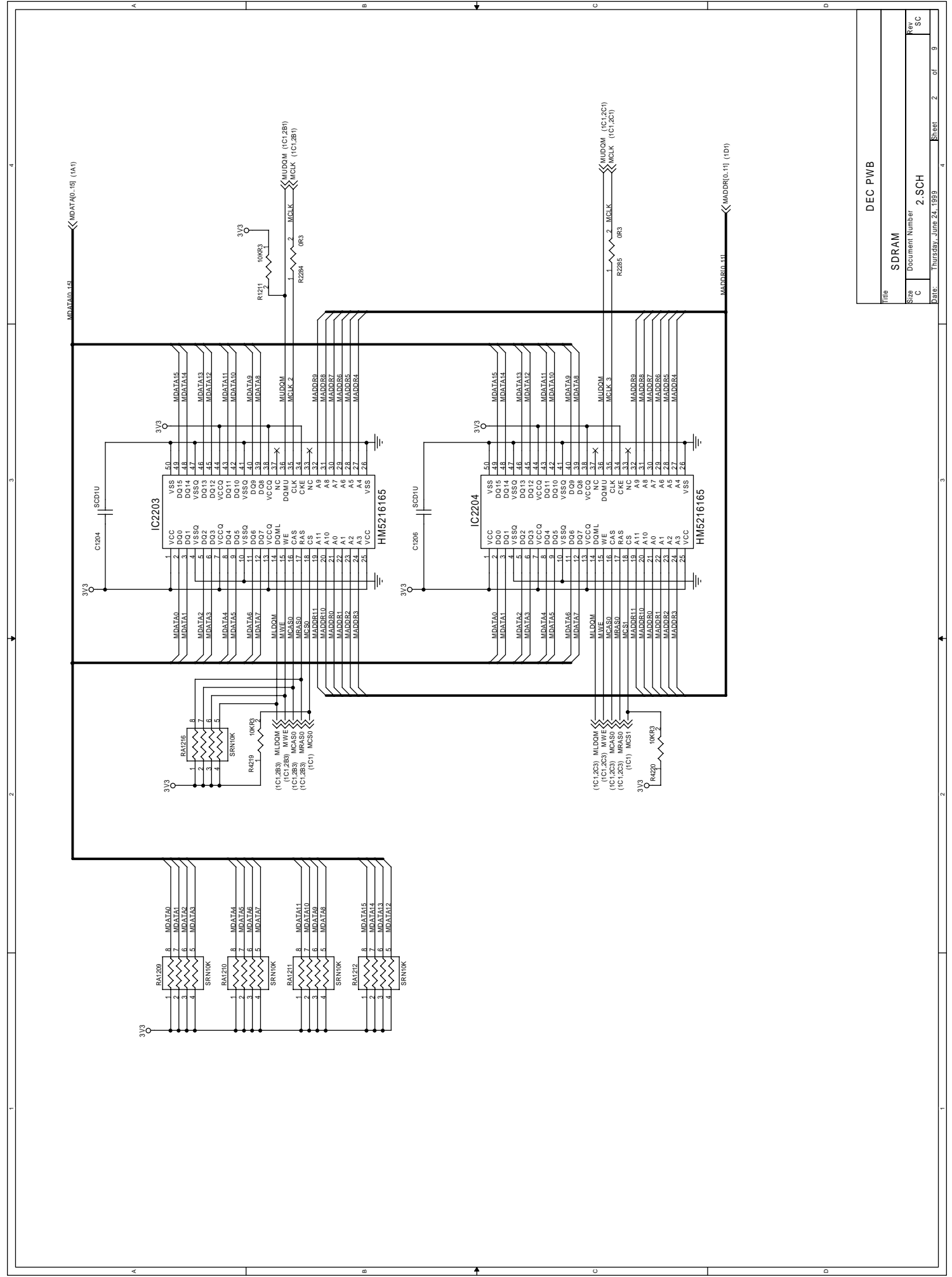

Title		DEC PWB	
Size		SDRAM	
Document Number		2.SCH	
Rev	SC	Sheet	2 of 9
Date: Thursday, June 24, 1999			

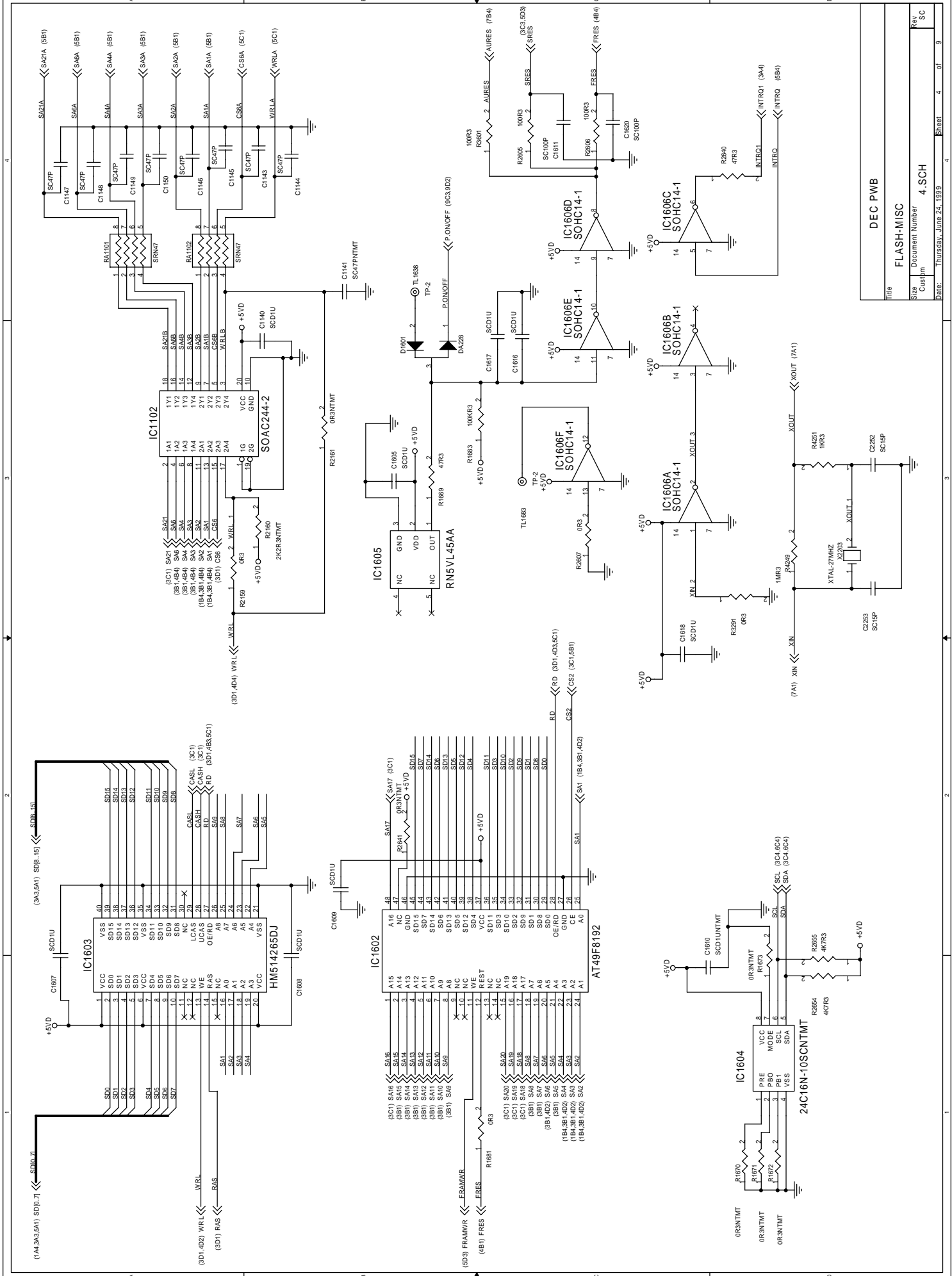

File	FLASH-MISC
Size	Document Number
Sheet	4-SCH
Date:	Thursday, June 24, 1999
Sheet	4 of 9

Title	DEC PWB
Customer	FLASH-MISC
Document Number	4-SCH
Rev	SC

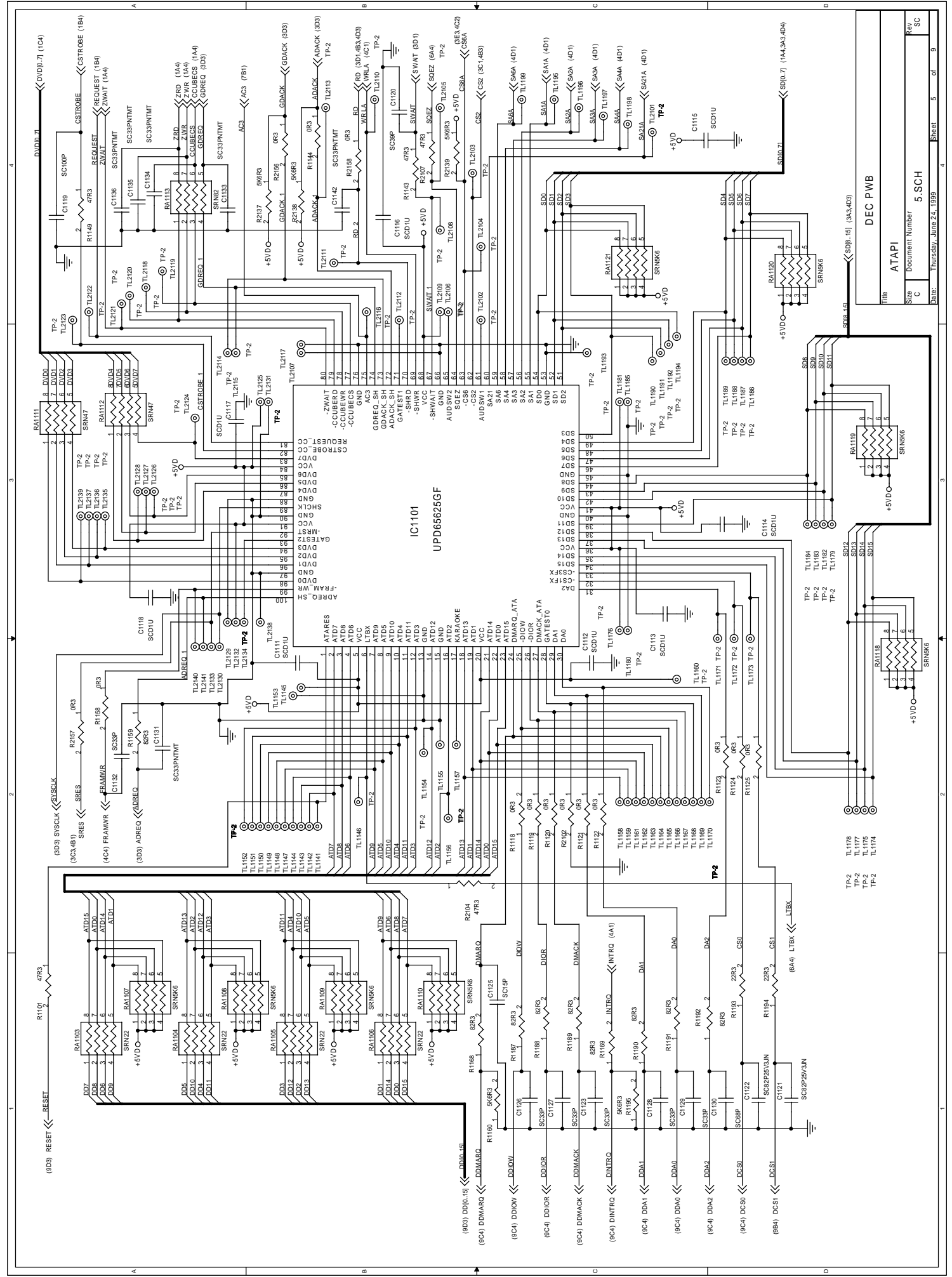

UPD656250F

Rev	SC
Document Number	5.SCH
Date:	Tuesday, June 24, 1999
Sheet	5 of 9

ATAPI
DEC PWB

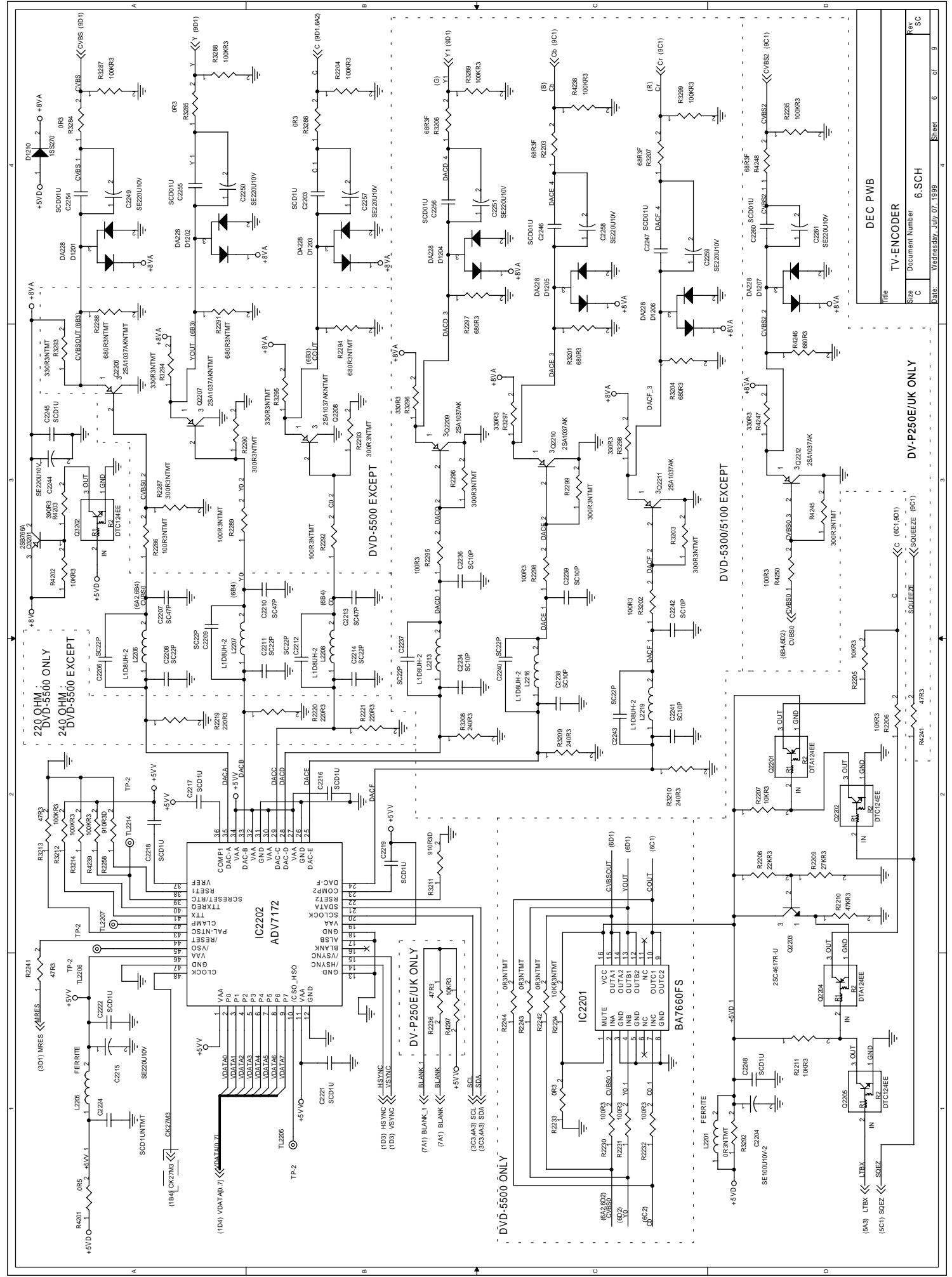

File	DEC PWB
Doc Number	TV-ENCODER
Rev	6-SCH
Date	Wednesday, July 07, 1999
Sheet	6 of 9

DV-P250E/UK ONLY

DVD-5300/5100 EXCEPT

DVD-5500 EXCEPT

DVD-5500 ONLY

DV-P250E/UK ONLY

DVD-5300/5100 EXCEPT

DVD-5500 EXCEPT

DVD-5500 ONLY

DV-P250E/UK ONLY

DVD-5300/5100 EXCEPT

DVD-5500 EXCEPT

DVD-5500 ONLY

DV-P250E/UK ONLY

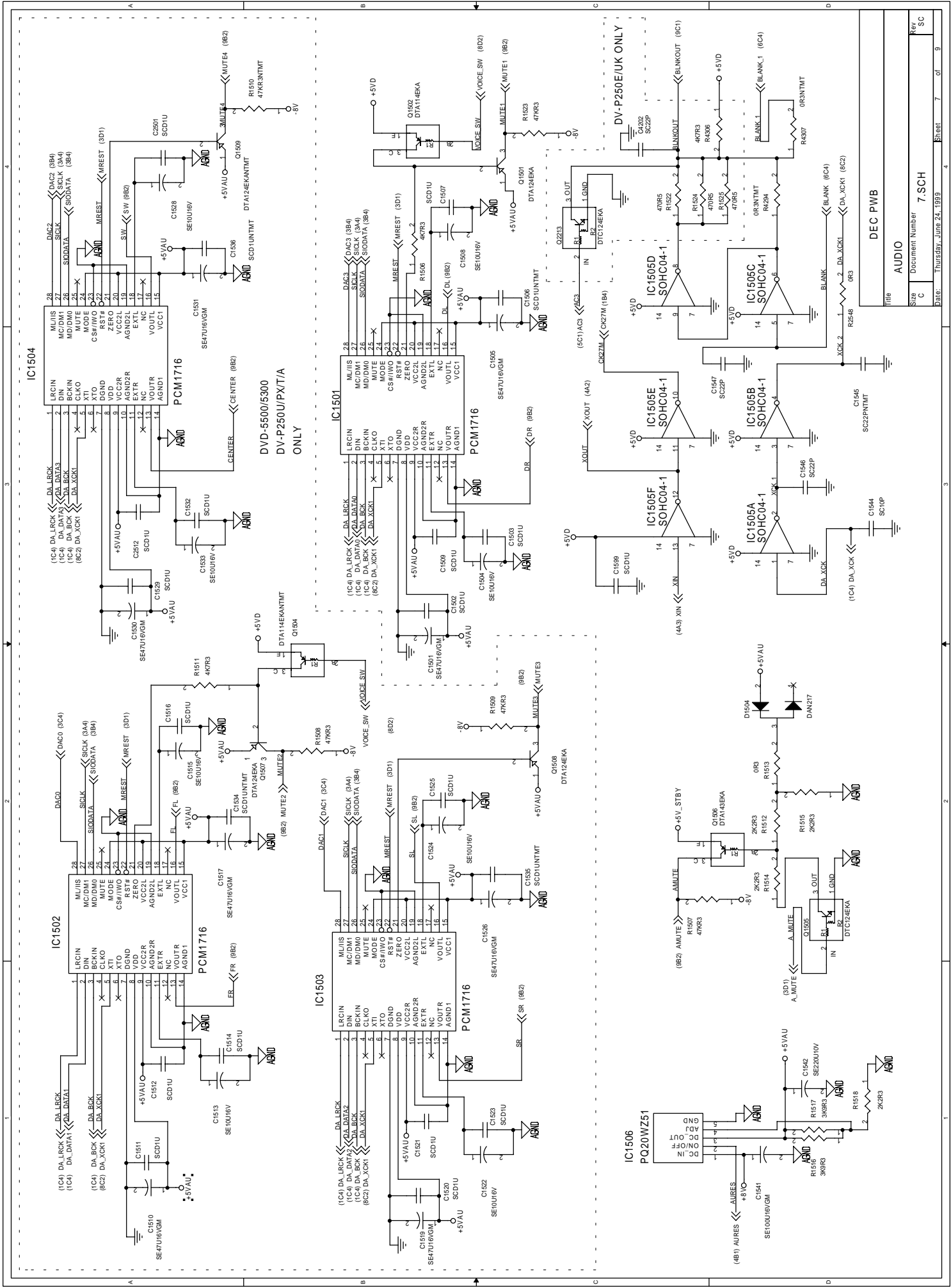

File	DEC PWB
Size	Document Number
C	7.SCH
Rev	7 of 9
SC	

Date: Thursday, June 24, 1999
 Sheet 7 of 9

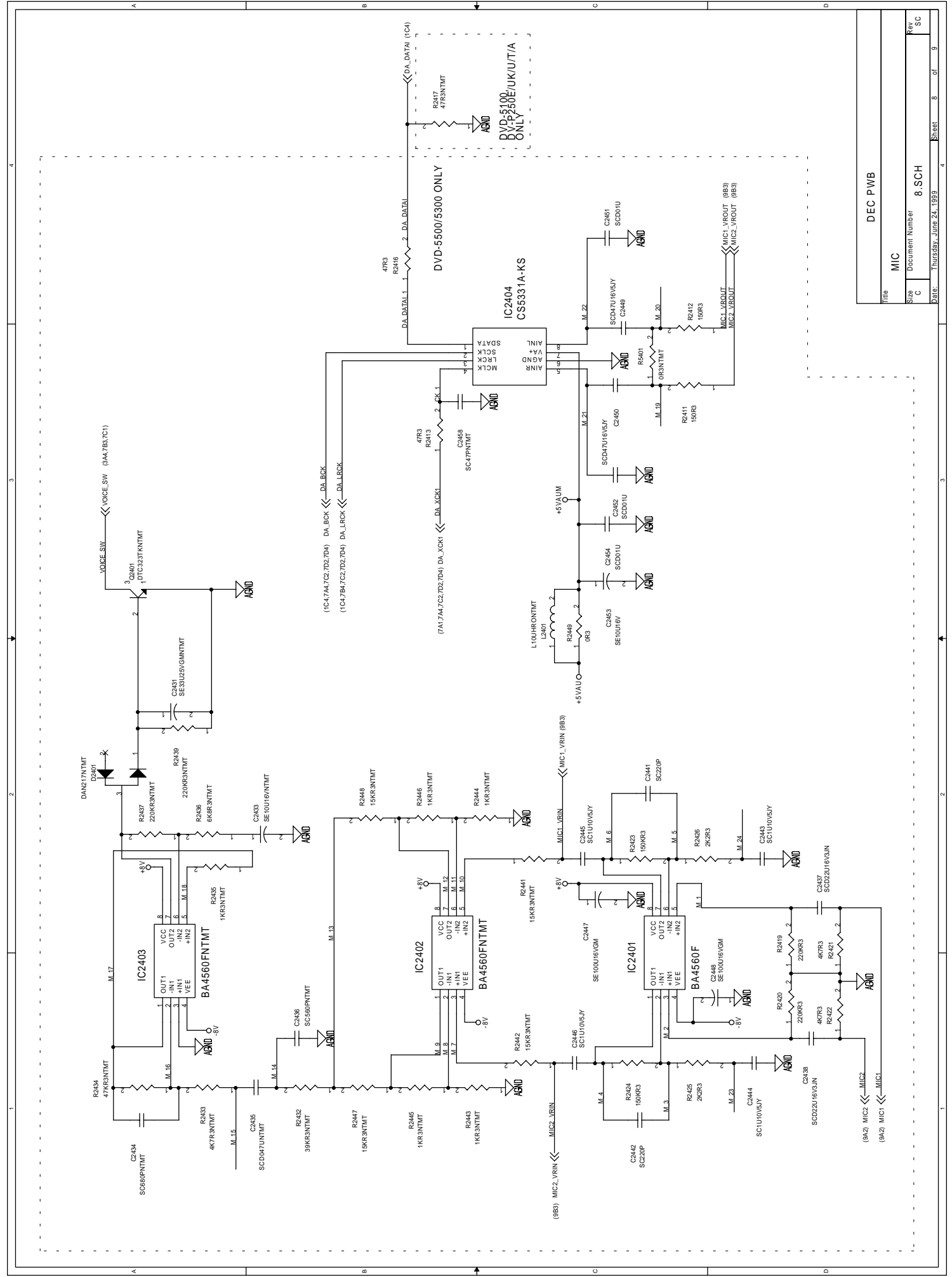

Title		DEC PWB	
C		MIC	
Size	Document Number	8	SCH
Rev			
Date:	Thursday, June 24, 1999	Sheet	8 of 9

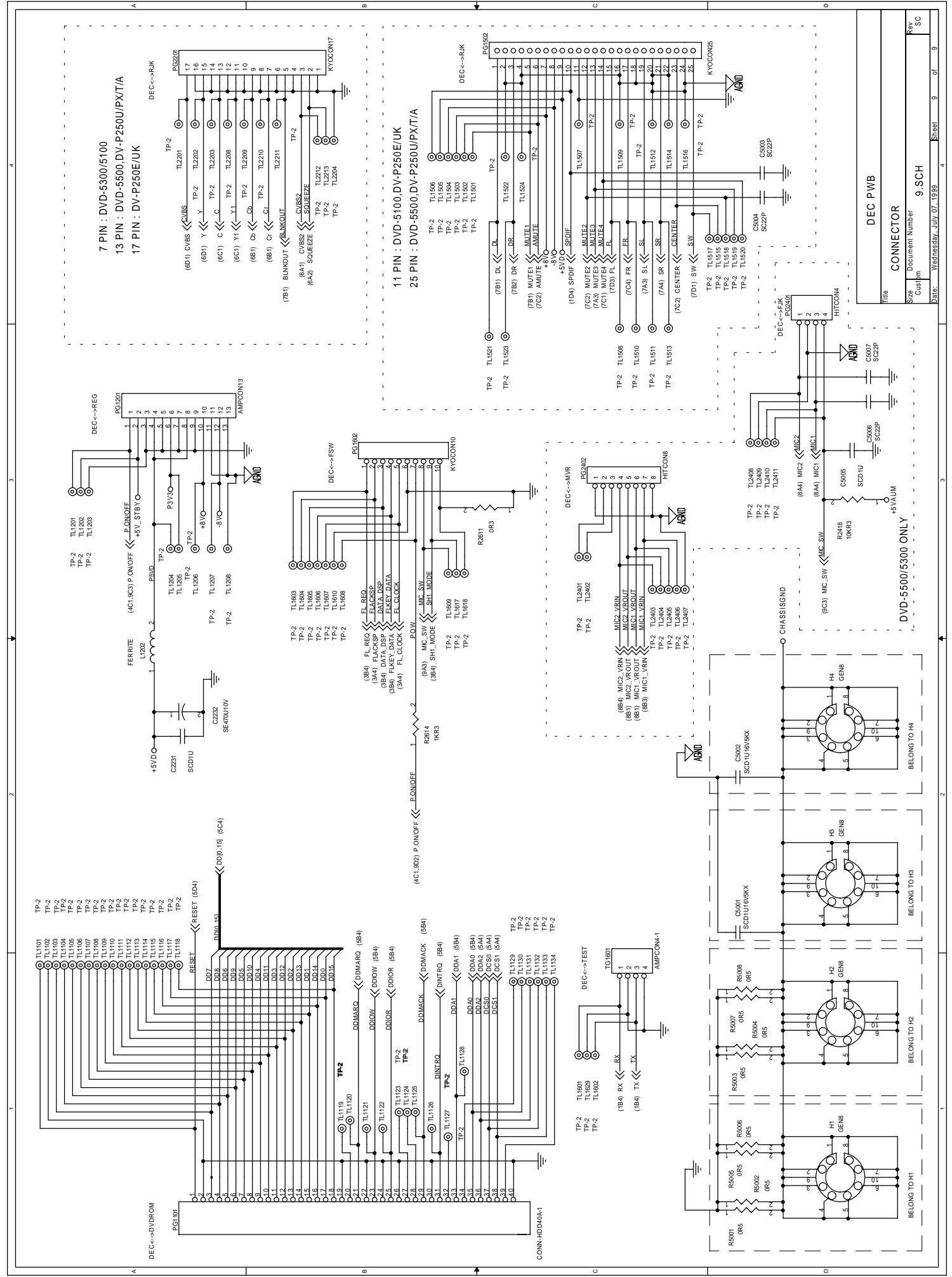

7 PIN : DVD-5300/5100
 13 PIN : DVD-5500.DV-P250U/PT/A
 17 PIN : DV-P250E/UK

11 PIN : DVD-5100.DV-P250E/UK
 25 PIN : DVD-5500.DV-P250U/PT/A

File	DEC PWB		
Size	Sheet	9	of 9
Docu	Document Number	9_SCH	
Rev	Date:	Wednesday, July 07, 1999	

DVD-5500/5300 ONLY

257A181/257A201/257A211

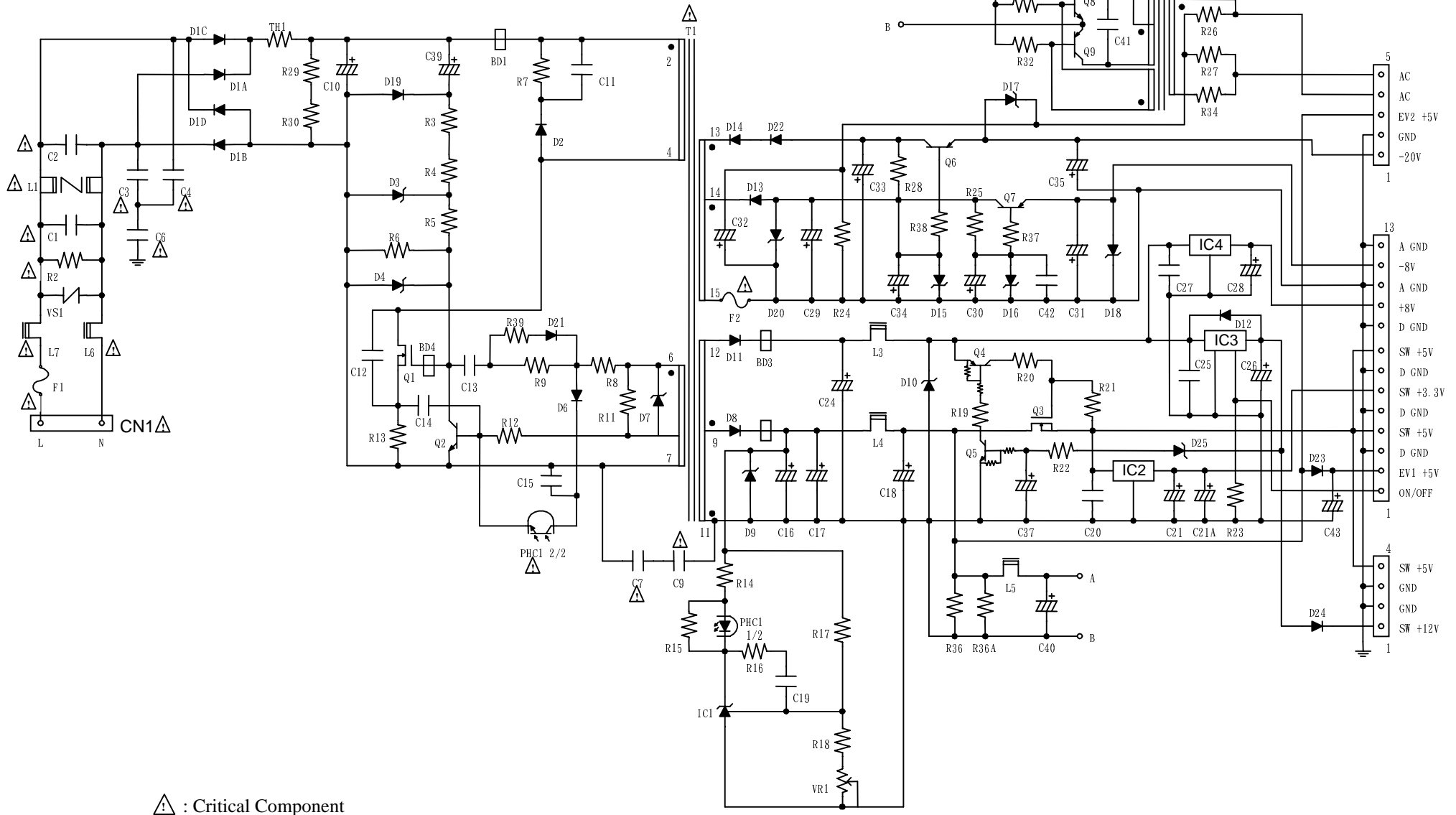

⚠ : Critical Component

* Detail different list of RJK PWB.

The 'x' mark means not used parts.

The 'O' mark means used parts.

MODEL	[S]	R3527 R3528	[5.1]	PG1301	PG1302	[C]	[D]	R3521 R1310 R1311	R3301 R3303 R3305	R3302 R3304 R3306
DV-P250E/(UK)	O	O	x	11P	17P	x	O	O	x	0 OHM
DV-P250U	x	x	O	25P	13P	O	O	x	x	0 OHM
DV-P250U PX	x	x	O	25P	13P	O	O	x	x	0 OHM
DV-P250A/(M)/(S)/(AU)	x	x	O	25P	13P	O	O	x	x	0 OHM
DVD-5500	x	x	O	25P	13P	O	O	x	68 OHM	68 OHM
DVD-5300	x	x	O	25P	7P	x	O	x	x	0 OHM
DVD-5100	x	x	x	11P	7P	x	x	O	x	0 OHM

HITACHI

DV-P250U/(PX)
DV-P250E/(UK)
DV-P250A/(M)/(S)/(AU)
DV-P250C

TK No. 9901E Digital Media Products Division, Tokai

Copyright© Hitachi, Ltd. 1999. All right reserved.

Printed in TAIWAN