

HITACHI

SERVICE MANUAL

TK

No. 9202E

DV-P325U
DV-P323U

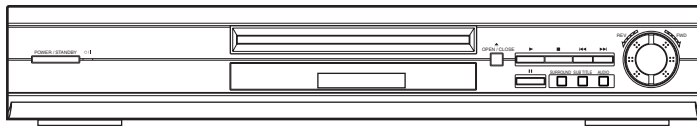

SPECIFICATIONS AND PARTS ARE SUBJECT TO CHANGE FOR IMPROVEMENT

DVD PLAYER

February

2002

Digital Media Products Division, Tokai

CONTENTS

SPECIFICATIONS	1-1-1
COMPARISON OF MODELS	1-2-1
LASER BEAM SAFETY PRECAUTIONS	1-3-1
IMPORTANT SAFETY PRECAUTIONS	1-4-1
Product Safety Notice	1-4-1
Precautions during Servicing	1-4-1
Safety Check after Servicing	1-4-2
STANDARD NOTES FOR SERVICING	1-5-1
Circuit Board Indications	1-5-1
Instructions for Connectors	1-5-1
How to Remove/Install Flat Pack-IC	1-5-1
Instructions for Handling Semi-conductors	1-5-3
OPERATING CONTROLS AND FUNCTIONS	1-6-1
CABINET DISASSEMBLY INSTRUCTIONS	1-7-1
1. Disassembly Flowchart	1-7-1
2. Disassembly Method	1-7-1
ROM RENEWAL MODE	1-8-1
TROUBLESHOOTING	1-9-1
BLOCK DIAGRAMS	1-10-1
System Control Block Diagram	1-10-1
RF Signal Process/Servo Block Diagram	1-10-2
DVD Signal Process Block Diagram	1-10-3
Video Block Diagram	1-10-4
Audio Block Diagram	1-10-5
Power Supply Block Diagram	1-10-6
SCHEMATIC DIAGRAMS/CBA'S AND TEST POINTS	1-11-1
DVD Main 1/4 Schematic Diagram	1-11-3
DVD Main 2/4 Schematic Diagram	1-11-4
DVD Main 3/4 Schematic Diagram	1-11-5
DVD Main 4/4 Schematic Diagram	1-11-6
AV 1/3 Schematic Diagram	1-11-7
AV 2/3 Schematic Diagram	1-11-8
AV 3/3, Function & Switch Schematic Diagram	1-11-10
AV CBA Top View	1-11-11
AV CBA Bottom View	1-11-12
Function CBA Top View	1-11-13
Function CBA Bottom View	1-11-13
Switch CBA Top View	1-11-13
Switch CBA Bottom View	1-11-13
WAVEFORMS	1-11-9
WIRING DIAGRAM	1-12-1
SYSTEM CONTROL TIMING CHARTS	1-13-1
IC PIN FUNCTION DESCRIPTIONS	1-14-1
LEAD IDENTIFICATIONS	1-15-1
EXPLODED VIEWS	1-16-1
MECHANICAL PARTS LIST	1-17-1
ELECTRICAL PARTS LIST	1-18-1

SPECIFICATIONS

Product type :	DVD Player
Discs :	DVD video Audio CD Video CD
Output signal format :	NTSC color
Frequency response	
DVD (linear sound) :	20 Hz to 22 kHz (sample rate: 48 kHz) 20 Hz to 44 kHz (sample rate: 96 kHz)
CD :	20 Hz to 20 kHz
Signal-to-noise ratio (S/N ratio)	
CD :	110 dB (JEITA)
Dynamic range	
DVD (linear sound) :	95 dB
CD :	94 dB (JEITA)
Total distortion factor	
CD :	0.005% (JEITA)
Wow and flutter :	Below the measurement limitation (+/-0.001% W PEAK) (JEITA)
Connections	
S-Video output :	Mini DIN 4-pin jack (75 ohm)
Video output :	One RCA connector, 1 Vpp (75 ohm)
Coaxial digital audio output :	One pin jack, 500mVpp (75 ohm)
Analog audio output :	Two RCA connectors (one left channel, one right channel) 2 Vrms (47 k ohm)
Component video output :	One pin jack (Y), 1 Vpp (75 ohm) Two pin jacks (C _B)/(C _R), 700mVpp (75 ohm)
Optical digital audio output :	Optical connector (DV-P325U only)
Power source :	120 V AC +/- 10%, 60 Hz +/- 0.5%
Power consumption :	14 W (standby: 2.2W)
Operating temperature :	5°C to 40°C
Dimensions :	W 17-1/8" (435mm) H 2-15/16" (75mm) D 8-1/2" (216mm)
Weight :	4.63 lbs (2.1kg)

- Designs and specifications are subject to change without notice.
- If there is a discrepancy between languages, the default language will be English.

Manufactured under license from Dolby Laboratories. "Dolby" and the double-D symbol are trademarks of Dolby Laboratories. Confidential Unpublished Works.
(©1992-1997 Dolby Laboratories, Inc. All rights reserved.)

"DTS" and "DTS Digital Out" are trademarks of Digital Theater Systems Inc.

COMPARISON OF MODELS

←: Same as on left

	DV-P315U/P313U	DV-P325U/323U
Appearance		
Dimensional	430(W) x 240(H) x 79(D) mm	435(W) x 216(H) x 75(D) mm
Weight	4.2kg	2.1kg
Tray Panel	Black	Silver
Color Front / Button	Black/Black	Black/Silver (DV-P325U) Silver/Silver (DV-P323U)
Hot Stamp	---	←
Ultra Vision Badge	---	←
General		
Drive Speed	1x	←
Laser	1	2
DVD/VCD/SVCD/CD-DA	O / O / O / O	O / O / --- / O
CD-R/CD-RW/DVD-R	--- / --- / ---	O / O / O
DVD-RAM	---	←
JPEG Play back	---	←
MP3	---	O
OSD languages	6 (English, French, Spanish, Italian, German, Dutch)	3 (English, French, Spanish)
Jog Shuttle on Front	---	Only switch Shuttle
Headphone Jack / Volume	--- / ---	←
AC Power Plug	Flat 2p(U)	←
Video		
PAL Disc NTSC Out	---	←
Video Out Mode NTSC/PAL/PAL60	O / --- / ---	←
S-Video / Component / Composite	O / O / O	←
Video D/A Converter	10bit	←
Black Level Select	O	←
Picture Control	---	←
Progressive Out	---	←
Audio		
Audio D/A Converter	96kHz / 24bit	192kHz / 24bit
Digital Audio Out Optical / Coaxial	O / O	O / O (DV-P325U) --- / O (DV-P323U)
Dolby Digital 5.1 ch Decode	---	←
DTS Digital Out	O	←
Virtual Surround	O	O (DV-P325U) --- (DV-P323U)
Dynamic Range Compression (Dolby Digital)	O	←
DVD Audio	---	←
Power on sound	---	←
Trick Play		
Search Speed	2 to 128 (F/R)	2 to 60 (F/R)
Slow Speed	1/8, 1/4, 1/2 (F only)	1/16, 1/8, 1/2 (F only)
IP Search (Smooth 2x Play)	O	←
2x Play with Audio	---	←
Step Forward / Reverse	O / ---	←
Still Picture Select (Frame/Field)	O	Auto Only

Features		
Disc Navigation	O (DV-P315U) --- (DV-P313U)	---
DVD Zoom x2 / x4 / x16	O / O / ---	←
Program and Random Play of DVD / VCD	O / O	---
A-B Repeat	O	←
Repeat	O	←
Last Play	O	←
Closed Caption for NTSC DVD	O	←
Front Panel Display Dimmer	O	←
Screen Saver	O	←
Auto Power Off	O	←
Remote Controller		
Jog Shuttle on Remote	---	←
TV Control	---	O
Accessory		
Remote Controller	O	←
Battery	O	←
AV Cable	O	←
S Cable	---	←
AC Socket	---	←
Warranty Card	O	←

LASER BEAM SAFETY PRECAUTIONS

This DVD player uses a pickup that emits a laser beam.

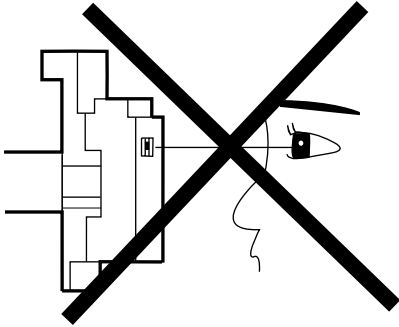

Do not look directly at the laser beam coming from the pickup or allow it to strike against your skin.

The laser beam is emitted from the location shown in the figure. When checking the laser diode, be sure to keep your eyes at least 30cm away from the pickup lens when the diode is turned on. Do not look directly at the laser beam.

Caution: Use of controls and adjustments, or doing procedures other than those specified herein, may result in hazardous radiation exposure.

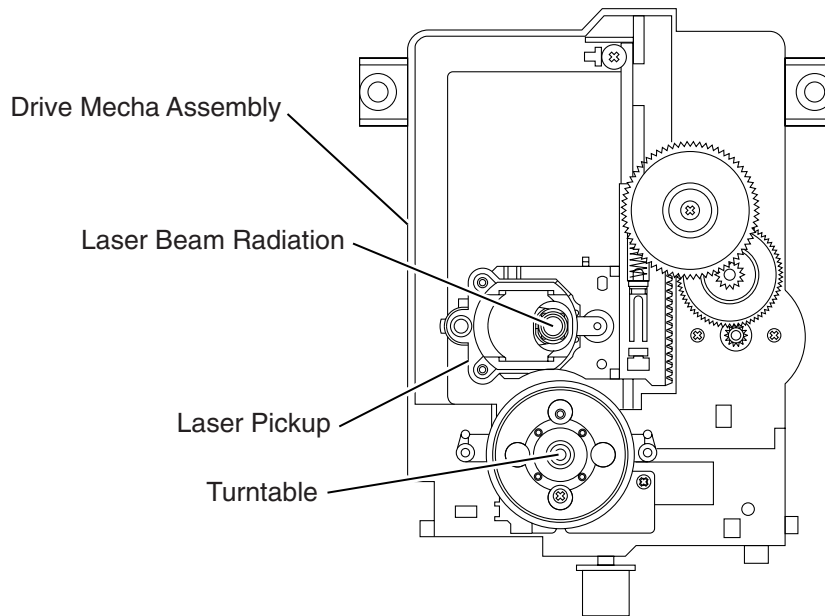

CAUTION
LASER RADIATION
WHEN OPEN. DO NOT
STARE INTO BEAM.

Location: Inside Top of DVD mechanism.

IMPORTANT SAFETY PRECAUTIONS

Product Safety Notice

Some electrical and mechanical parts have special safety-related characteristics which are often not evident from visual inspection, nor can the protection they give necessarily be obtained by replacing them with components rated for higher voltage, wattage, etc. Parts that have special safety characteristics are identified by a **▲** on schematics and in parts lists. Use of a substitute replacement that does not have the same safety characteristics as the recommended replacement part might create shock, fire, and/or other hazards. The Product's Safety is under review continuously and new instructions are issued whenever appropriate. Prior to shipment from the factory, our products are carefully inspected to confirm with the recognized product safety and electrical codes of the countries in which they are to be sold. However, in order to maintain such compliance, it is equally important to implement the following precautions when a set is being serviced.

Precautions during Servicing

- A.** Parts identified by the **▲** symbol are critical for safety. Replace only with part number specified.
- B.** In addition to safety, other parts and assemblies are specified for conformance with regulations applying to spurious radiation. These must also be replaced only with specified replacements.
Examples: RF converters, RF cables, noise blocking capacitors, and noise blocking filters, etc.
- C.** Use specified internal wiring. Note especially:
 - 1) Wires covered with PVC tubing
 - 2) Double insulated wires
 - 3) High voltage leads
- D.** Use specified insulating materials for hazardous live parts. Note especially:
 - 1) Insulation tape
 - 2) PVC tubing
 - 3) Spacers
 - 4) Insulators for transistors
- E.** When replacing AC primary side components (transformers, power cord, etc.), wrap ends of wires securely about the terminals before soldering.
- F.** Observe that the wires do not contact heat producing parts (heatsinks, oxide metal film resistors, fusible resistors, etc.).
- G.** Check that replaced wires do not contact sharp edges or pointed parts.
- H.** When a power cord has been replaced, check that 5 - 6 kg of force in any direction will not loosen it.
- I.** Also check areas surrounding repaired locations.
- J.** Be careful that foreign objects (screws, solder droplets, etc.) do not remain inside the set.
- K.** Crimp type wire connector
The power transformer uses crimp type connectors which connect the power cord and the primary side of the transformer. When replacing the transformer, follow these steps carefully and precisely to prevent shock hazards.
Replacement procedure
 - 1) Remove the old connector by cutting the wires at a point close to the connector.
Important: Do not re-use a connector. (Discard it.)
 - 2) Strip about 15 mm of the insulation from the ends of the wires. If the wires are stranded, twist the strands to avoid frayed conductors.
 - 3) Align the lengths of the wires to be connected. Insert the wires fully into the connector.
 - 4) Use a crimping tool to crimp the metal sleeve at its center. Be sure to crimp fully to the complete closure of the tool.
- L.** When connecting or disconnecting the internal connectors, first, disconnect the AC plug from the AC outlet.

Safety Check after Servicing

Examine the area surrounding the repaired location for damage or deterioration. Observe that screws, parts, and wires have been returned to their original positions. Afterwards, do the following tests and confirm the specified values to verify compliance with safety standards.

1. Clearance Distance

When replacing primary circuit components, confirm specified clearance distance (d) and (d') between soldered terminals, and between terminals and surrounding metallic parts. (See Fig. 1)

Table 1 : Ratings for selected area

AC Line Voltage	Clearance Distance (d) (d')
120 V	$\geq 3.2\text{mm}$ (0.126 inches)

Note: This table is unofficial and for reference only.
Be sure to confirm the precise values.

2. Leakage Current Test

Confirm the specified (or lower) leakage current between B (earth ground, power cord plug prongs) and externally exposed accessible parts (RF terminals, antenna terminals, video and audio input and output terminals, microphone jacks, earphone jacks, etc.) is lower than or equal to the specified value in the table below.

Measuring Method (Power ON) :

Insert load Z between B (earth ground, power cord plug prongs) and exposed accessible parts. Use an AC voltmeter to measure across the terminals of load Z. See Fig. 2 and the following table.

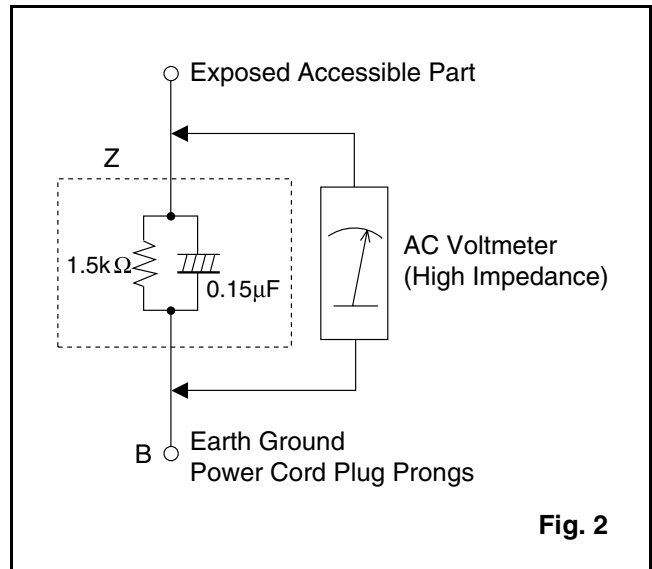
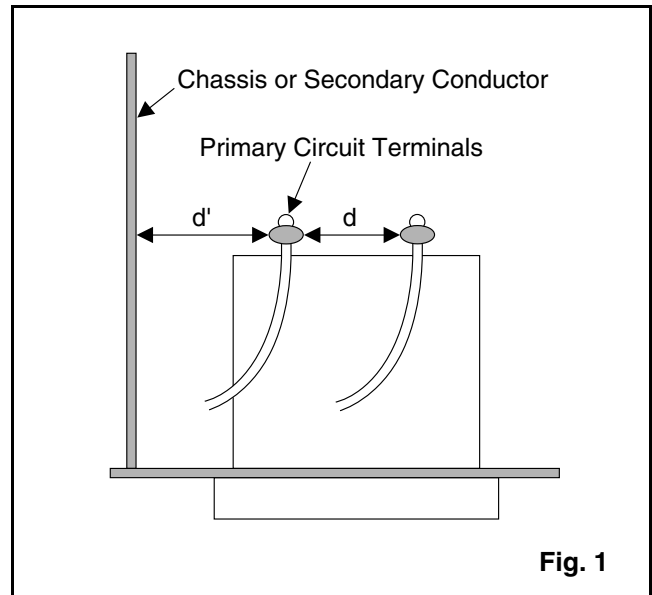

Table 2: Leakage current ratings for selected areas

AC Line Voltage	Load Z	Leakage Current (i)	Earth Ground (B) to:
120 V	$0.15\mu\text{F}$ CAP. & $1.5\text{k}\Omega$ RES. Connected in parallel	$i \leq 0.5\text{mA}$ Peak	Exposed accessible parts

Note: This table is unofficial and for reference only. Be sure to confirm the precise values.

STANDARD NOTES FOR SERVICING

Circuit Board Indications

- a. The output pin of the 3 pin Regulator ICs is indicated as shown.

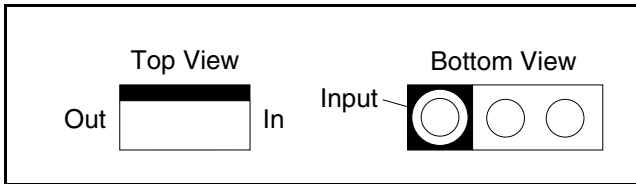

- b. For other ICs, pin 1 and every fifth pin are indicated as shown.

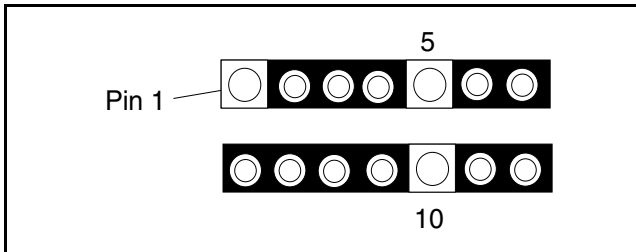

- c. The 1st pin of every male connector is indicated as shown.

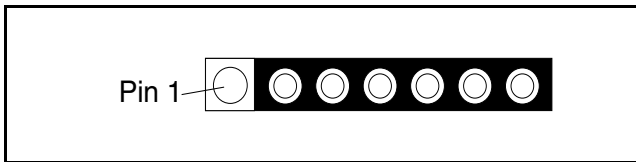

Instructions for Connectors

- When you connect or disconnect the FFC (Flexible Foil Connector) cable, be sure to first disconnect the AC cord.
- FFC (Flexible Foil Connector) cable should be inserted parallel into the connector, not at an angle.

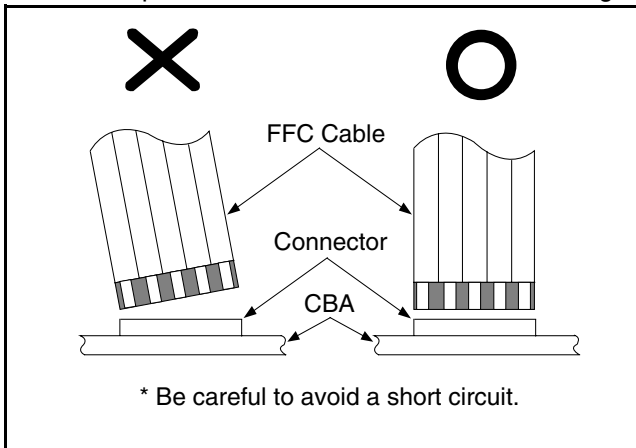

How to Remove / Install Flat Pack-IC

1. Removal

With Hot-Air Flat Pack-IC Desoldering Machine:

- (1) Prepare the hot-air flat pack-IC desoldering machine, then apply hot air to the Flat Pack-IC (about 5 to 6 seconds). (Fig. S-1-1)

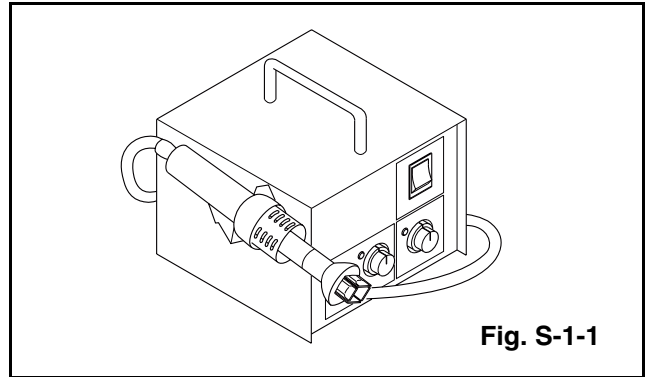

- (2) Remove the flat pack-IC with tweezers while applying the hot air.
- (3) Bottom of the flat pack-IC is fixed with glue to the CBA; when removing entire flat pack-IC, first apply soldering iron to center of the flat pack-IC and heat up. Then remove (glue will be melted). (Fig. S-1-6)
- (1) Release the flat pack-IC from the CBA using tweezers. (Fig. S-1-6)

Caution:

- Do not supply hot air to the chip parts around the flat pack-IC for over 6 seconds because damage to the chip parts may occur. Put masking tape around the flat pack-IC to protect other parts from damage. (Fig. S-1-2)
- The flat pack-IC on the CBA is affixed with glue, so be careful not to break or damage the foil of each pin or the solder lands under the IC when removing it.

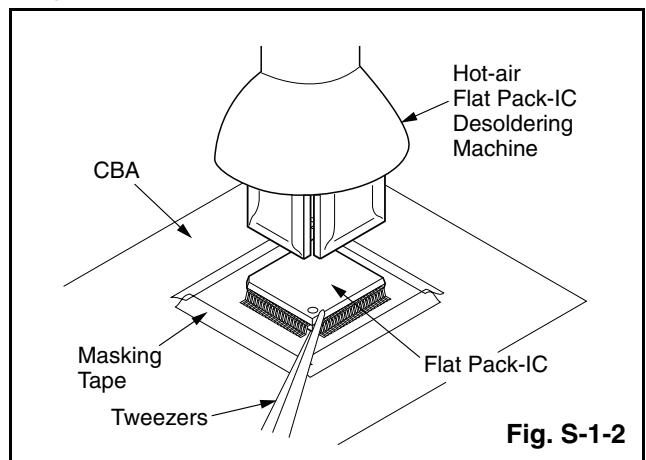

With Soldering Iron:

- (1) Using desoldering braid, remove the solder from all pins of the flat pack-IC. When you use solder flux which is applied to all pins of the flat pack-IC, you can remove it easily. (Fig. S-1-3)

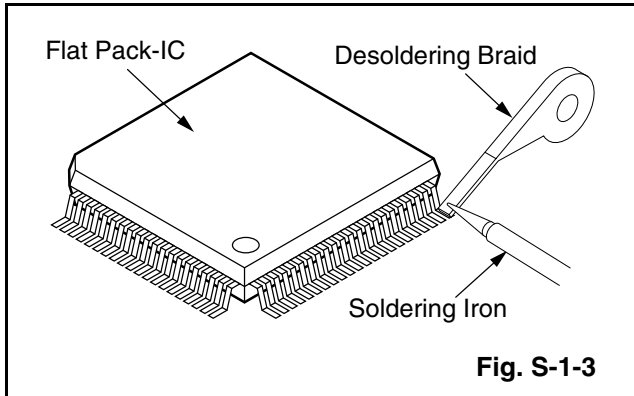

- (2) Lift each lead of the flat pack-IC upward one by one, using a sharp pin or wire to which solder will not adhere (iron wire). When heating the pins, use a fine tip soldering iron or a hot air desoldering machine. (Fig. S-1-4)

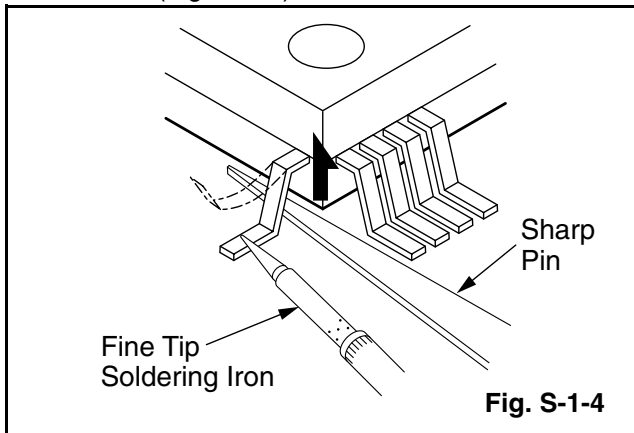

- (3) Bottom of the flat pack-IC is fixed with glue to the CBA; when removing entire flat pack-IC, first apply soldering iron to center of the flat pack-IC and heat up. Then remove (glue will be melted). (Fig. S-1-6)

- (4) Release the flat pack-IC from the CBA using tweezers. (Fig. S-1-6)

With Iron Wire:

- (1) Using desoldering braid, remove the solder from all pins of the flat pack-IC. When you use solder flux which is applied to all pins of the flat pack-IC, you can remove it easily. (Fig. S-1-3)

- (2) Affix the wire to a workbench or solid mounting point, as shown in Fig. S-1-5.

- (3) While heating the pins using a fine tip soldering iron or hot air blower, pull up the wire as the solder melts so as to lift the IC leads from the CBA contact pads as shown in Fig. S-1-5

- (4) Bottom of the flat pack-IC is fixed with glue to the CBA; when removing entire flat pack-IC, first apply soldering iron to center of the flat pack-IC and heat up. Then remove (glue will be melted). (Fig. S-1-6)

- (5) Release the flat pack-IC from the CBA using tweezers. (Fig. S-1-6)

Note:

When using a soldering iron, care must be taken to ensure that the flat pack-IC is not being held by glue. When the flat pack-IC is removed from the CBA, handle it gently because it may be damaged if force is applied.

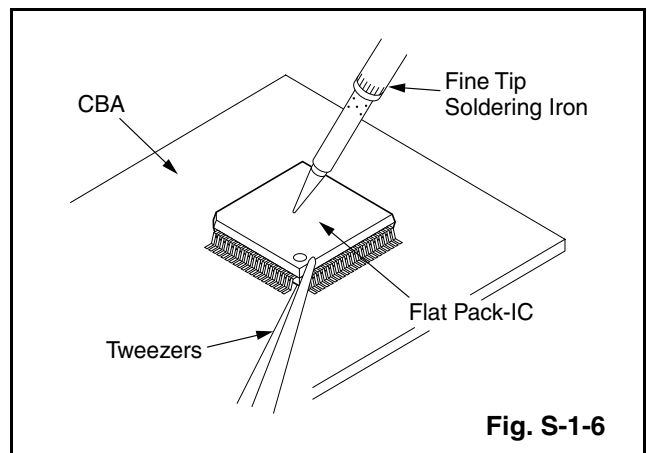
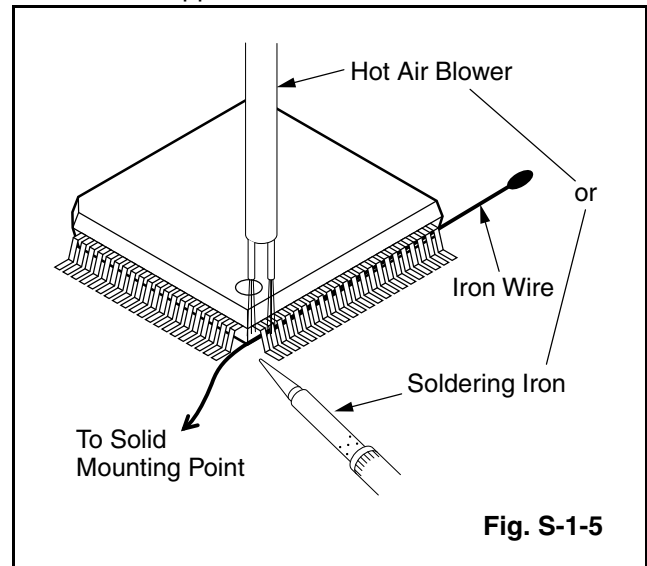

2. Installation

- (1) Using desoldering braid, remove the solder from the foil of each pin of the flat pack-IC on the CBA so you can install a replacement flat pack-IC more easily.
- (2) The "●" mark on the flat pack-IC indicates pin 1. (See Fig. S-1-7.) Be sure this mark matches the 1 on the PCB when positioning for installation. Then presolder the four corners of the flat pack-IC. (See Fig. S-1-8.)
- (3) Solder all pins of the flat pack-IC. Be sure that none of the pins have solder bridges.

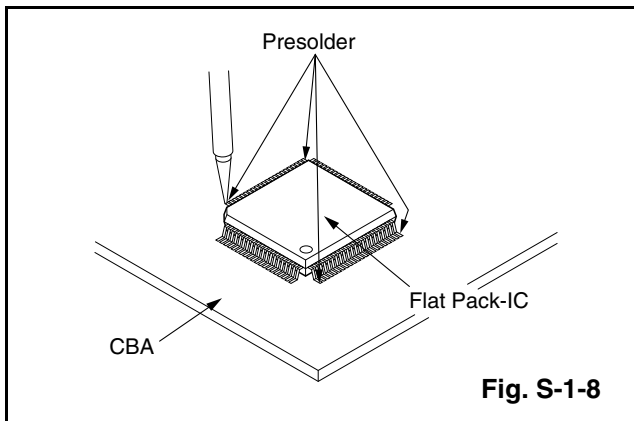
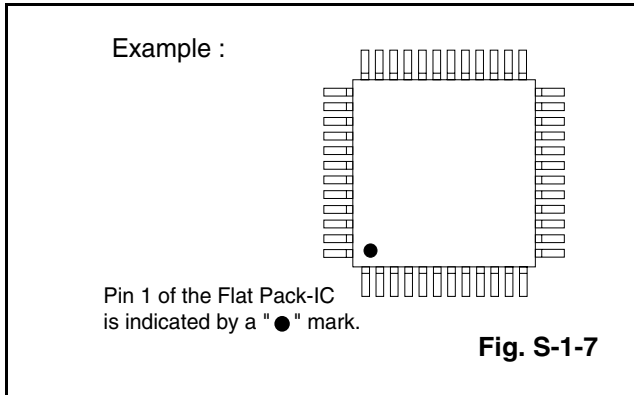

Instructions for Handling Semi-conductors

Electrostatic breakdown of the semi-conductors may occur due to a potential difference caused by electrostatic charge during unpacking or repair work.

1. Ground for Human Body

Be sure to wear a grounding band ($1M\Omega$) that is properly grounded to remove any static electricity that may be charged on the body.

2. Ground for Workbench

- (4) Be sure to place a conductive sheet or copper plate with proper grounding ($1M\Omega$) on the workbench or other surface, where the semi-conductors are to be placed. Because the static electricity charge on clothing will not escape through the body grounding band, be careful to avoid contacting semi-conductors with your clothing.

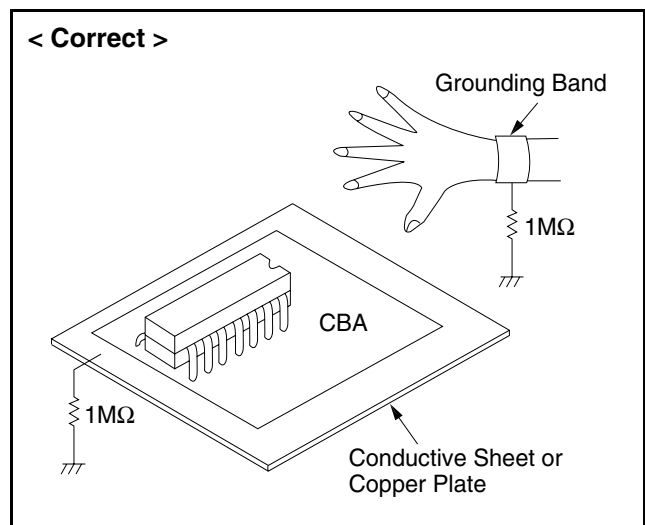
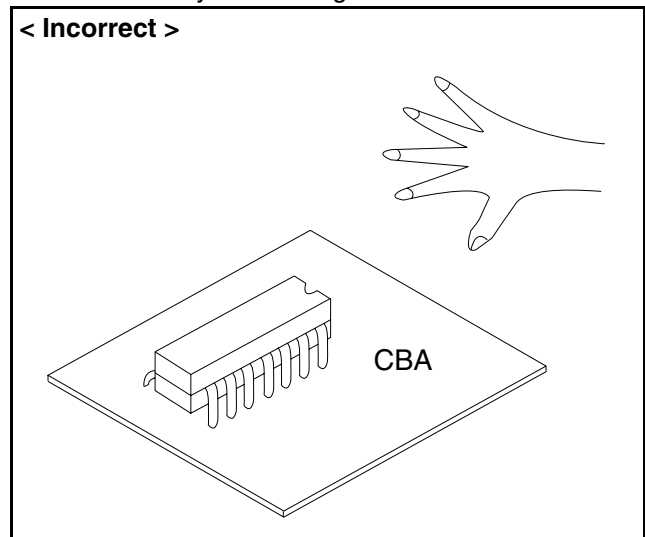

OPERATING CONTROLS AND FUNCTIONS

FRONT PANEL

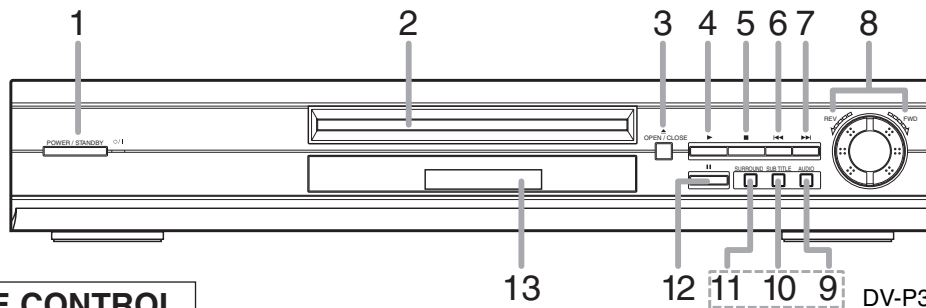

REMOTE CONTROL

DV-P325U only

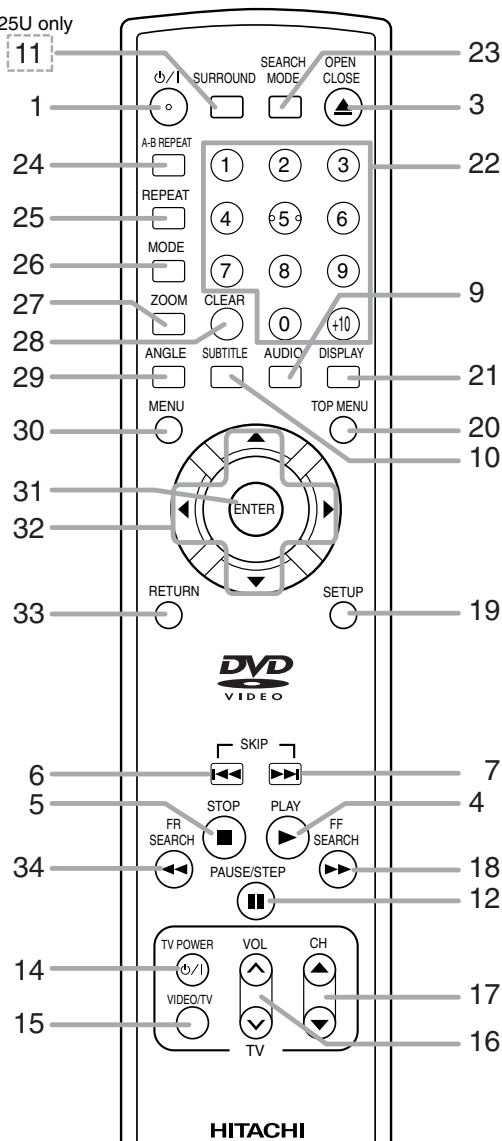

1. $\phi/1$ (POWER/STANDBY) Button
2. Disc loading tray
3. OPEN/CLOSE Button
4. PLAY Button

5. **STOP Button**
6. **SKIP DOWN/REV Button**
Plays back from the beginning of the current chapter or track. Hold down to fast reverse playback.
7. **SKIP UP/FWD Button**
Plays back from the beginning of the next chapter or track. Hold down to fast forward playback.
8. **Shuttle Ring (REV/FWD)**
Turn to make rewind or fast forward speed faster in the forward or backward direction in the Play mode or Still mode. The further the Shuttle Ring is rotated, the faster the playback speed.
9. **AUDIO Button**
Press to select a desired audio language or sound mode.
10. **SUBTITLE Button**
Press to select a desired subtitle language.
11. **SURROUND Button**
12. **PAUSE/STEP Button]**
13. **Display, Remote Sensor Window**
14. **TV POWER Button**
15. **VIDEO/TV Button**
16. **VOL Button**
17. **CH Button**
18. **FF SEARCH Button**
19. **SETUP Button**
20. **TOP MENU Button**
21. **DISPLAY Button**
22. **Numeric Buttons**
23. **SEARCH MODE Button**
24. **A-B REPEAT Button**
25. **REPEAT Button**
26. **MODE Button**
27. **ZOOM Button**
28. **CLEAR Button**
29. **ANGLE Button**
Press to change the camera angle to see the sequence being played back from a different angle.
30. **MENU Button**
31. **ENTER Button**
32. **Arrow Buttons**
Use when making settings while watching the display on a TV screen.
33. **RETURN Button**
34. **FR SEARCH Button**

DISPLAY

Stays on when the A-B repeat function is on.

Stays on when the repeat function is on.

Lights up when a DVD is inserted on the tray.

Lights up when the inserted disc comes to a pause.

Stays on when the inserted disc is being played back.

Displays how long a current title or track has been played back. When a chapter or track has switched, the number of a new title, chapter or track is displayed.

CD:
Lights up when a CD is inserted on the tray.
VCD:
Lights up when a Video CD is inserted on the tray.

Lights up when a playback control is activated.

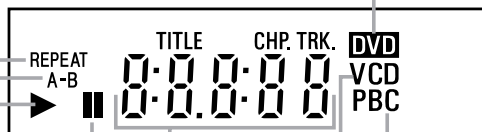

DISPLAYS DURING OPERATION

	Power on
	No disc inserted
	Tray open
	Tray closed
	Loading the Disc
	Power off

LOADING THE BATTERIES

1. Open the battery compartment cover.

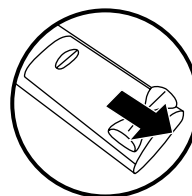

2. Insert two AA batteries, with each one oriented correctly.

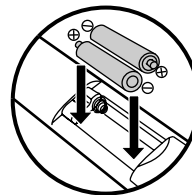

3. Close the cover.

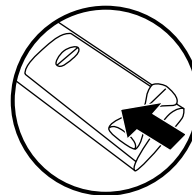

Notes

- Do not mix alkaline and manganese batteries.
- Do not mix old and new batteries.

DESCRIPTION-REAR PANEL

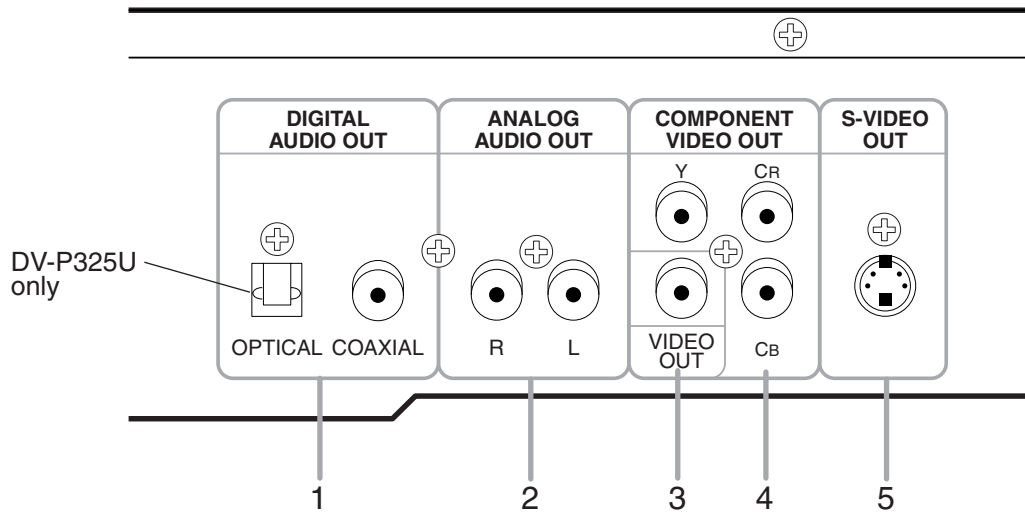

1. DIGITAL AUDIO OUT JACKS:

Use either an optical or coaxial digital cable to connect to a compatible Dolby Digital receiver. Use to connect to a Dolby Digital decoder or DTS decoder.

2. ANALOG AUDIO OUT JACKS

Connect to the Audio input jacks of A/V-compatible TV or wide screen TV, Stereo system.

3. VIDEO OUT JACK

Use a video cable to connect one of the jack to Video input on your A/V-compatible TV or wide screen TV, Stereo system.

4. COMPONENT VIDEO OUT JACKS

Use these jacks if you have a TV with Component Video in jacks. These jacks provide Cr, Cb and Y video. Along with S-Video, Component Video provides the best picture quality.

5. S-VIDEO OUT JACK

Use the S-Video cable to connect this jack to the S-Video jack on your A/V-compatible TV or wide screen TV for a higher quality picture.

Manufactured under license from Dolby Laboratories. "Dolby" and the double-D symbol are trademarks of Dolby Laboratories. Confidential Unpublished Works.

"DTS" and "DTS Digital Out" are registered trademarks of Digital Theater Systems, Inc.

CABINET DISASSEMBLY INSTRUCTIONS

1. Disassembly Flowchart

This flowchart indicates the disassembly steps to gain access to item(s) to be serviced. When reassembling, follow the steps in reverse order. Bend, route, and dress the cables as they were originally.

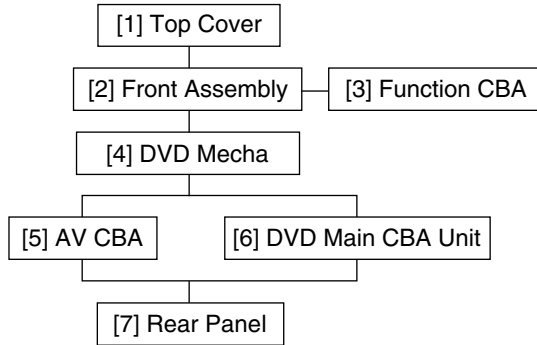

2. Disassembly Method

ID/ LOC. No.	PART	REMOVAL		
		Fig. No.	REMOVE/*UNHOOK/ UNLOCK/RELEASE/ UNPLUG/DESOLDER	Note
[1]	Top Cover	1	5(S-1)	-
[2]	Front Assembly	2	*2(L-1), Tray Panel, *2(L-2), *CN2002, *5(L-3),	1-1 1-2 1-3 1-4 1-5 1-6
[3]	Function CBA	3	5(S-2), Jog Shuttle Key	-
[4]	DVD Mecha	4,5	3(S-3), *CN101, *CN401	2 2-1 2-2 2-3 3
[5]	AV CBA	6	4(S-4), (S-5)--- DV-P325U only, 4(S-6), *2(L-4), *CN1001, *CN1601	-
[6]	DVD Main CBA Unit	6	3(S-7)	-
[7]	Rear Panel	7	3(S-8)	-

(1) (2) (3) (4) (5)

- (1): Identification (location) No. of parts in the figures
 (2): Name of the part
 (3): Figure Number for reference
 (4): Identification of parts to be removed, unhooked, unlocked, released, unplugged, unclamped, or desoldered.
 P=Spring, L=Locking Tab, S=Screw, CN=Connector
 *=Unhook, Unlock, Release, Unplug, or Desolder
 e.g. 2(S-2) = two Screws (S-2),
 2(L-2) = two Locking Tabs (L-2)
 (5): Refer to "Reference Notes."

Reference Notes

CAUTION 1: Locking Tabs (L-1), (L-2) and (L-3) are fragile. Be careful not to break them.

- 1-1. Connect the wall plug to an AC outlet and press the OPEN/CLOSE button to open the Tray.
- 1-2. Remove the Tray Panel by releasing two Locking Tabs (L-1).
- 1-3. Press the OPEN/CLOSE button again to close the Tray.
- 1-4. Press the POWER/STANDBY button to turn the power off and unplug an AC cord.
- 1-5. Disconnect connector CN2002.

- 1-7. Release two Locking Tabs (L-2). Then, release five Locking Tabs (L-3) (to do this, first release two Locking Tabs (A) at the side, and then three Locking Tabs (B) at the bottom.)

CAUTION 2: Electrostatic breakdown of the laser diode in the optical system block may occur as a potential difference caused by electrostatic charge accumulated on cloth, human body etc, during unpacking or repair work.

To avoid damage of pickup follow next procedures.

- 2-1. Slide out the pickup unit as shown in Fig. 5.
- 2-2. Short the three short lands of FPC cable with solder before removing the FFC cable (CN101) from it. If you disconnect the FFC cable (CN101), the laser diode of pickup will be destroyed. (Fig. 5)
- 2-3. Disconnect Connector (CN401). Remove three Screws (S-3) and lift the DVD Mecha. (Fig. 4)

CAUTION 3: When reassembling, confirm the FFC cable (CN101) is connected completely. Then remove the solder from the three short lands of FPC cable. (Fig. 5)

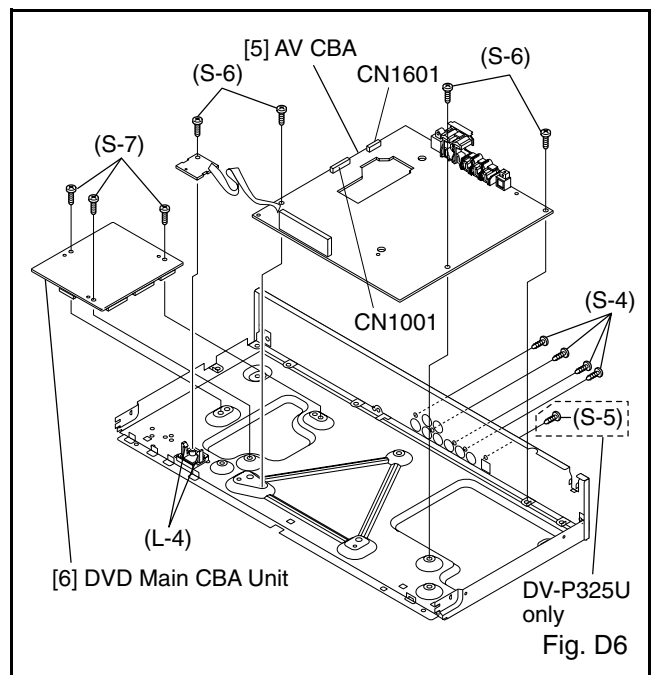
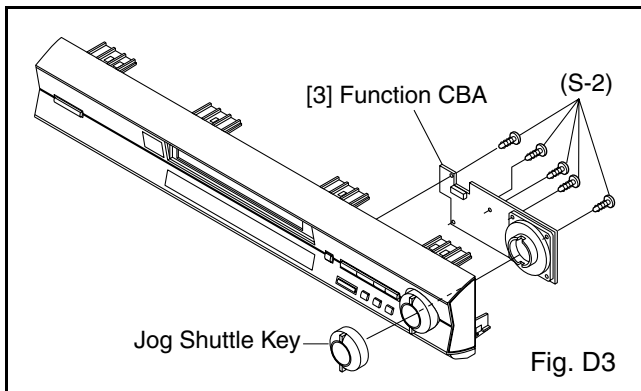
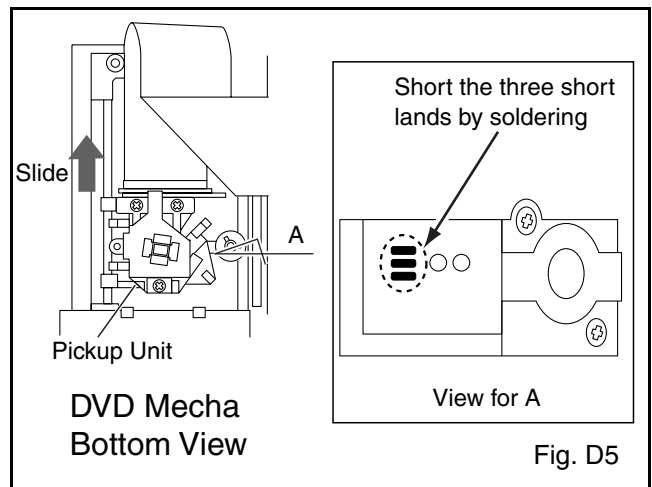
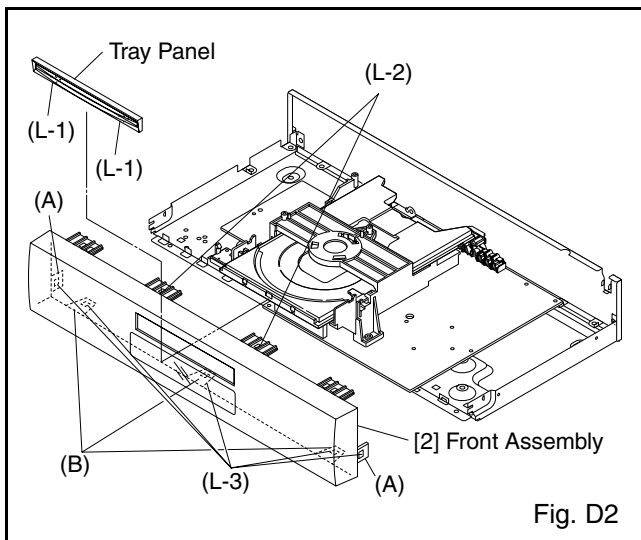
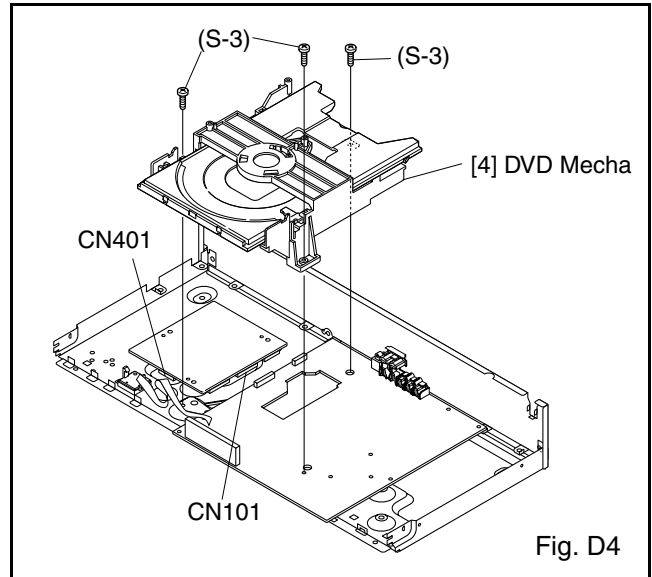
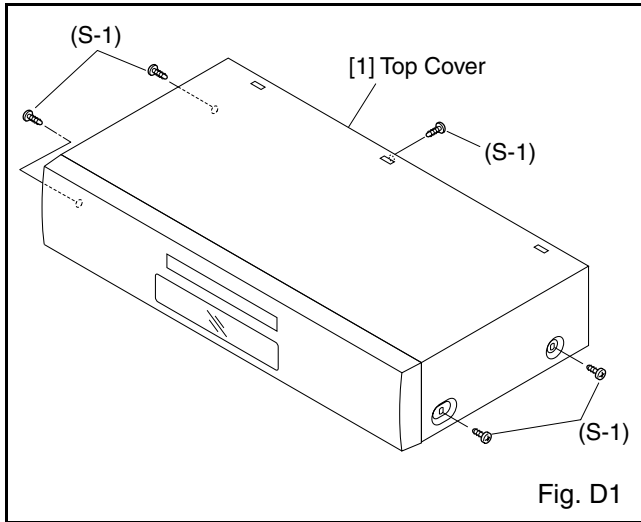

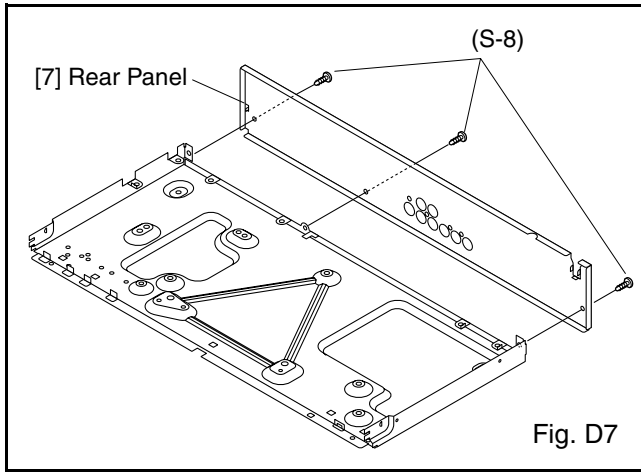

HOW TO MANUAL EJECT

1. Remove the Top Case.
2. Insert the eject-bar (length = approximately 80 mm, diameter = approximately 3 mm) into the manual eject hole on the DVD Mecha. Then, press it until the tray is ejected.

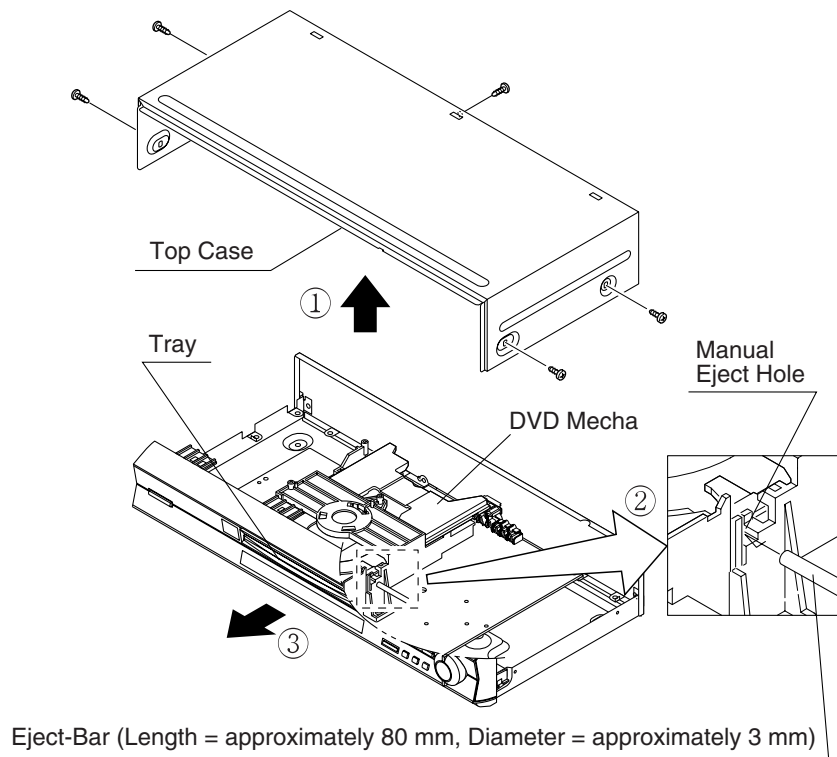

ROM RENEWAL MODE

1. Turn the power on and remove the disc on the tray.
2. To put the DVD player into version up mode, press [9], [8], [7], [6], and [SEARCH MODE] buttons on the remote control unit in that order. The tray will open automatically.

Fig. a appears on the screen and Fig. b appears on the VFD.

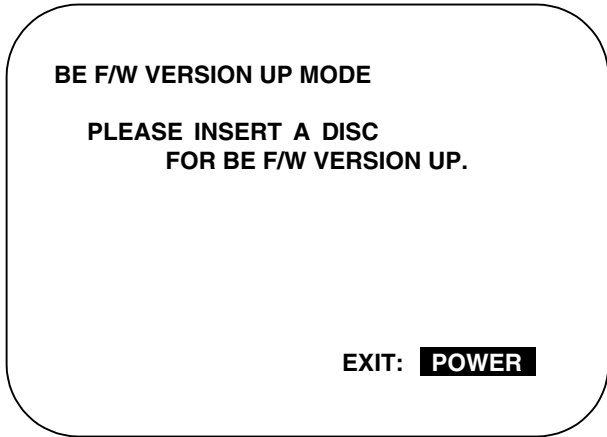

Fig. a Version Up Mode Screen

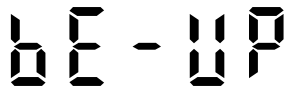

Fig. b VFD in Version Up Mode

The DVD player can also enter the version up mode with the tray open. In this case, Fig. a will be shown on the screen while the tray is open.

3. Load the disc for version up. (For closing the tray, only the "OPEN/CLOSE" button is available.)
4. The DVD player enters the F/W version up mode automatically. Fig. c appears on the screen and Fig. d appears on the VFD.

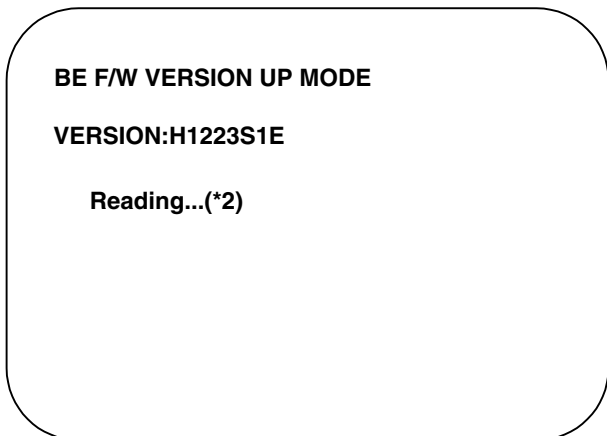

Fig. c Programming Mode Screen



Fig. d VFD in Programming Mode (Example)

The appearance shown in (*2) of Fig. c is described as follows:

No.	Appearance	State
1	Reading...	Sending files into the memory
2	Erasing...	Erasing previous version data
3	Programming...	Writing new version data

5. After programming is finished, the tray opens automatically. Fig. e appears on the screen and the checksum in (*3) of Fig. e appears on the VFD. (Fig. f)

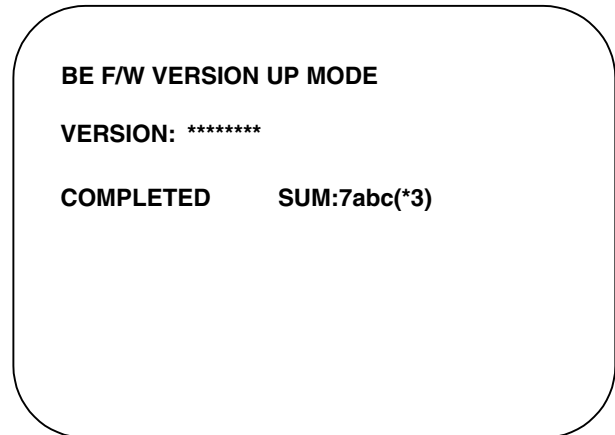

Fig. e Completed Program Mode Screen



Fig. f VFD upon Finishing the Programming Mode (Example)

At this time, no buttons are available.

6. For tray opening, plug the AC cord into the AC outlet.
7. Turn the power on by pressing the power button and the tray will close.

TROUBLESHOOTING

FLOW CHART NO.1

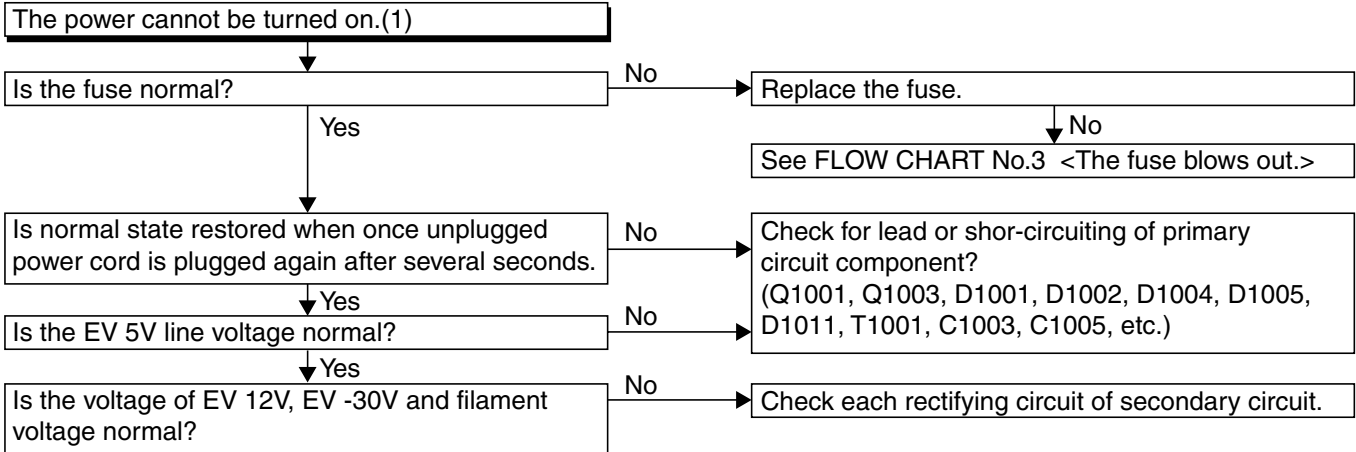

FLOW CHART NO.2

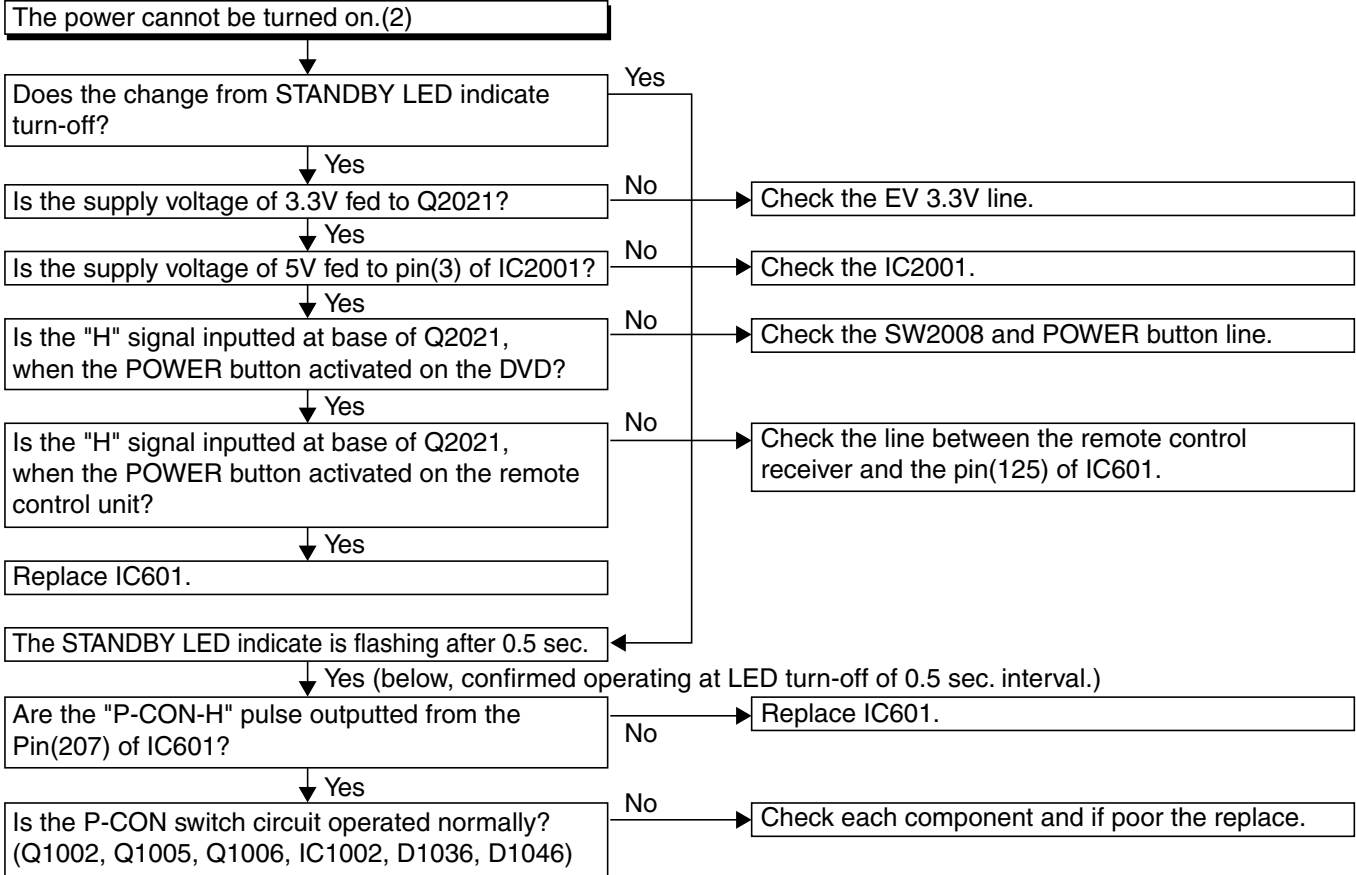

FLOW CHART NO.3

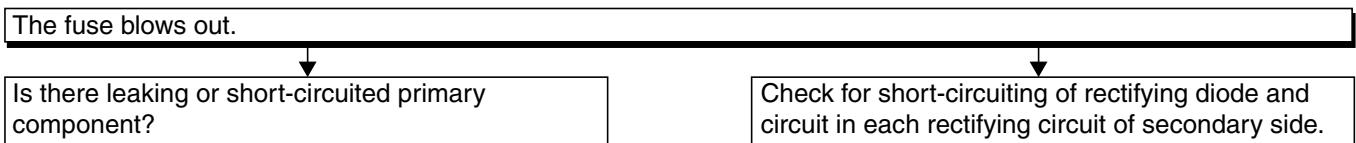

FLOW CHART NO.4

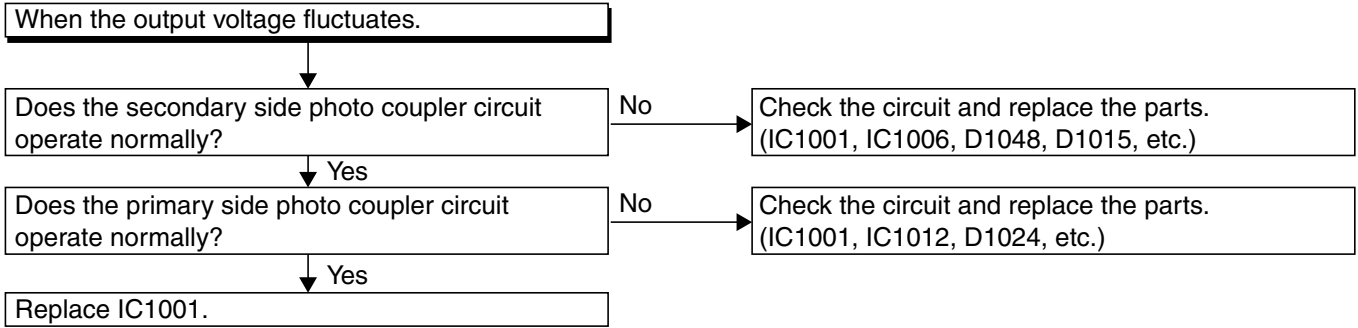

FLOW CHART NO.5

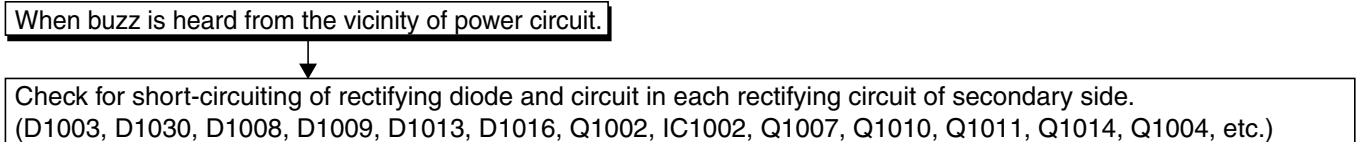

FLOW CHART NO.6

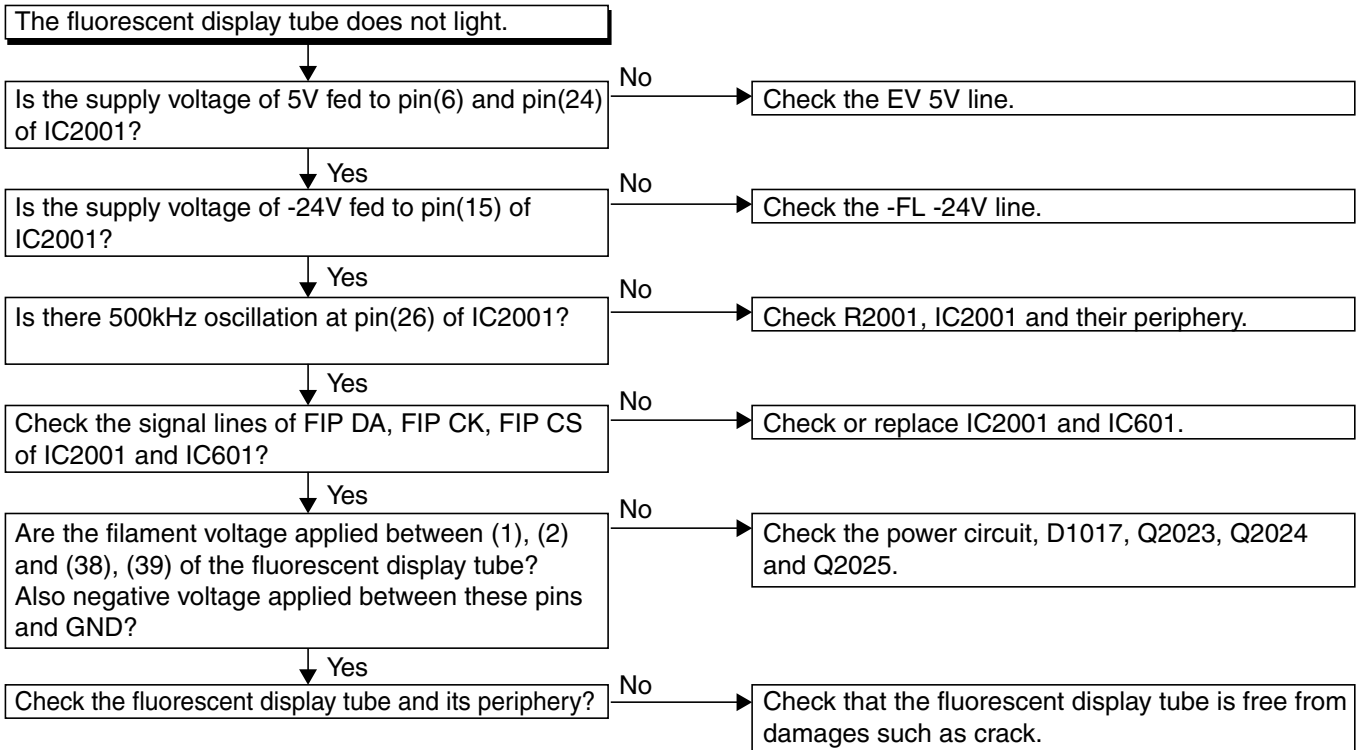

FLOW CHART NO.7

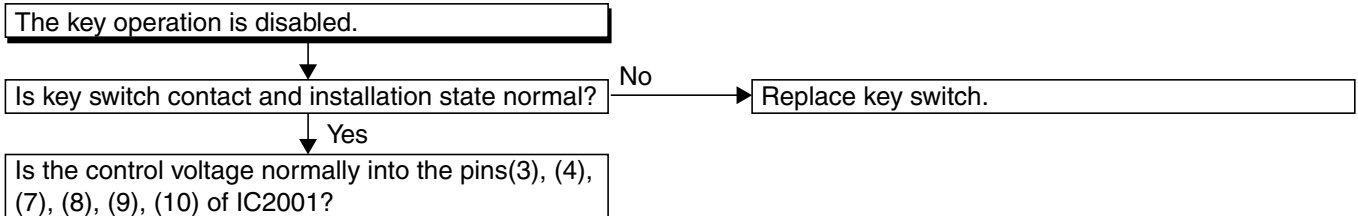

FLOW CHART NO.8

No operation is possible from the infrared remote control.

Operation is possible from the DVD, but no operation is possible from the infrared remote control?

No → Replace the remoter control receiver or replace the remoter control transmitter is necessary.

Yes

Is 5V voltage supplied to the pin(3) terminal of remote control receiver?

No → Check EV 5V line.

Yes

Is the "L" pulse sent out pin(1) terminal of receiver when the infrared remote control is activated?

No → Replace the remote control receiver.

Yes

Is pulse signal supplied to the pin(125) of IC601? (Although SEARCH(1), SEARCH(+), PLAY, STILL/PAUSE, STOP, POWER and OPEN/CLOSE button.)

No → Check the line between the remote control receiver and the pin(125) of IC601.

Yes → Replace IC601.

FLOW CHART NO.9

PON 12V is not outputted.

Is 12V voltage supplied at collector of Q1002?

No → Check the secondary circuit, AT 12V and the periphery circuit of Q1005 and Q1006.

Yes

Is voltage of 12V sent out from the emitter of Q1002.

Yes → Check for load circuit short-circuiting or leak.

No

Check the Q1002 periphery circuit.

Yes

Does the P-CON switch circuit operate normally? (Q1005, Q1006, D1036, etc.)

No → Check each component and if poor the replace.

Yes

Are the "H" pulse inputted into Q1002.

No → Check or replace Q1005, Q1006.

Yes

Replace Q1002.

FLOW CHART NO.10

PON 5V is not outputted. (PON 12V is possible.)

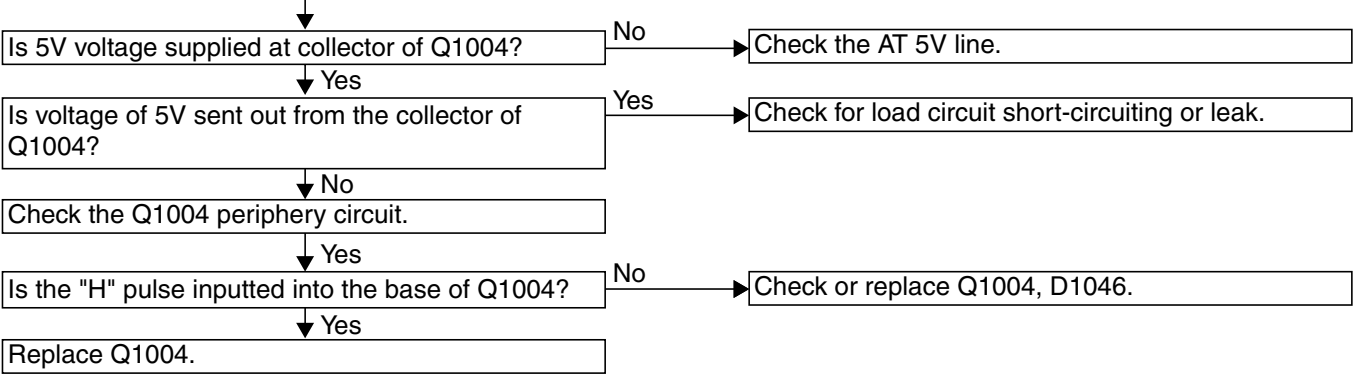

FLOW CHART NO.11

EV -19V is not outputted.

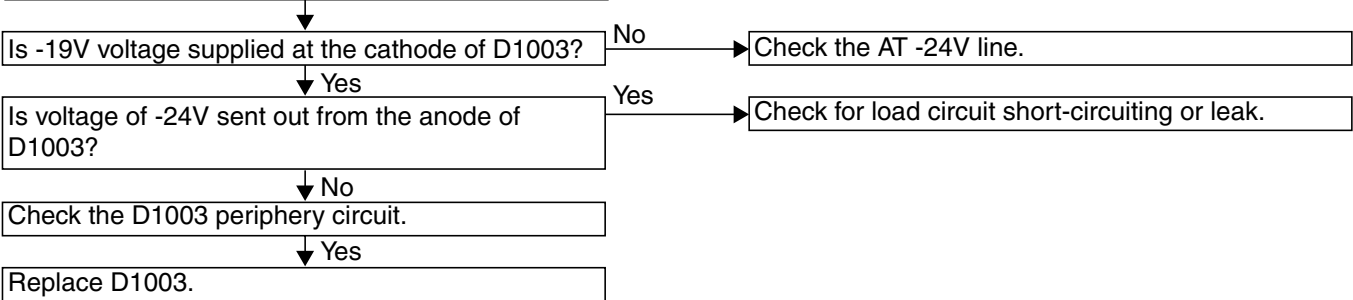

FLOW CHART NO.12

PON 3.3V(1), (2) is not outputted.

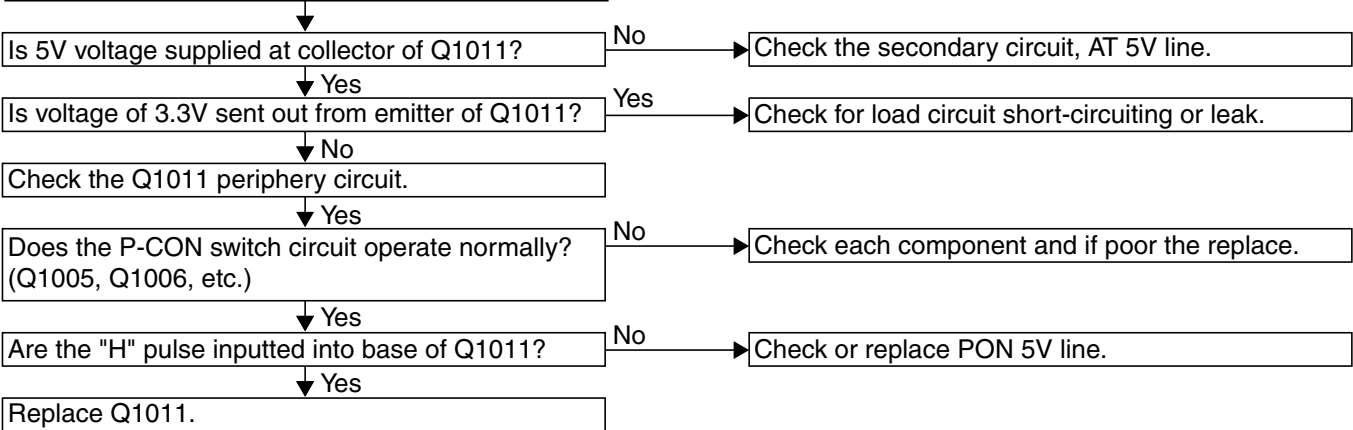

FLOW CHART NO.13

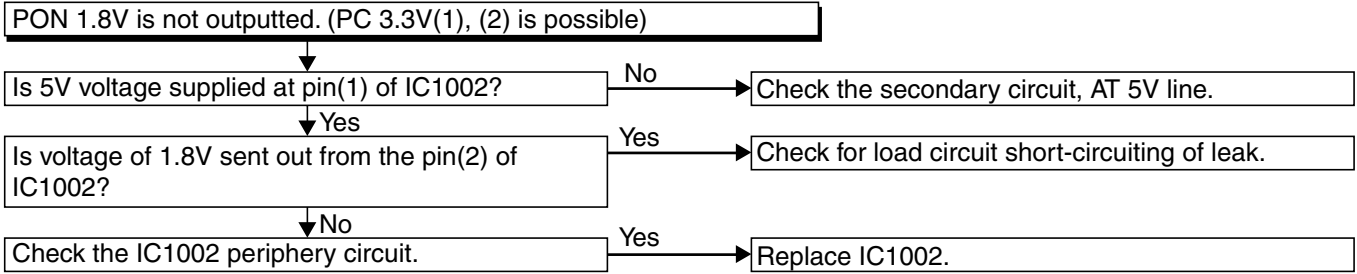

FLOW CHART NO.14

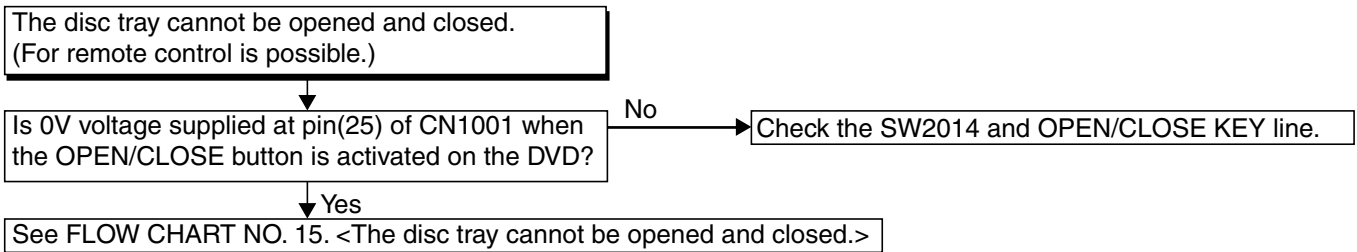

FLOW CHART NO.15

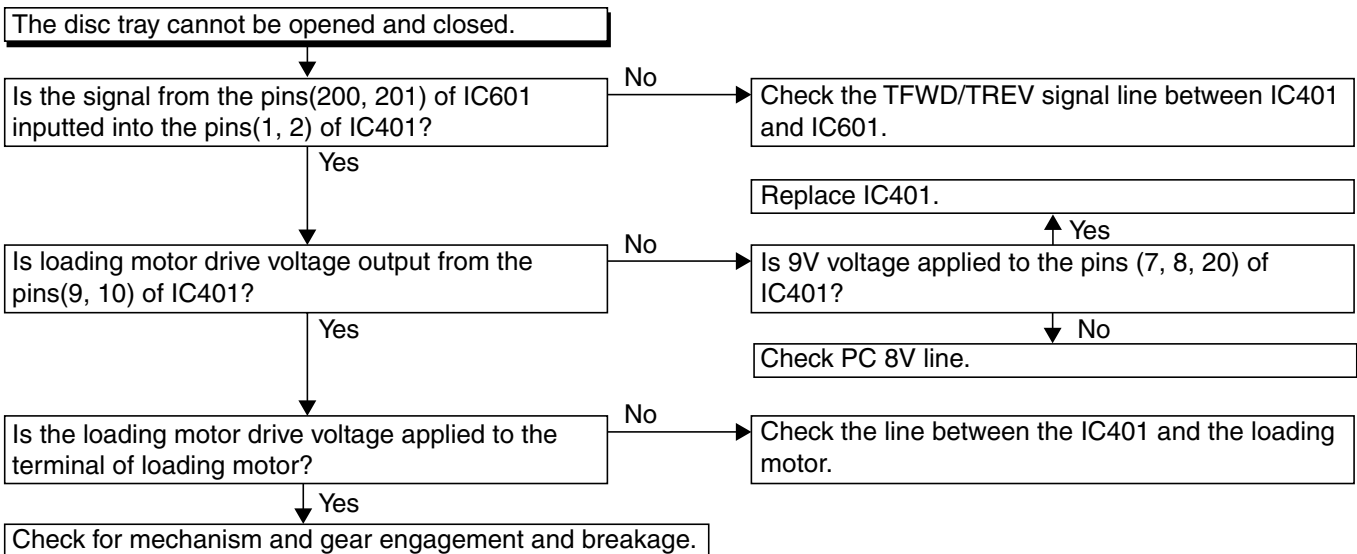

FLOW CHART NO.16

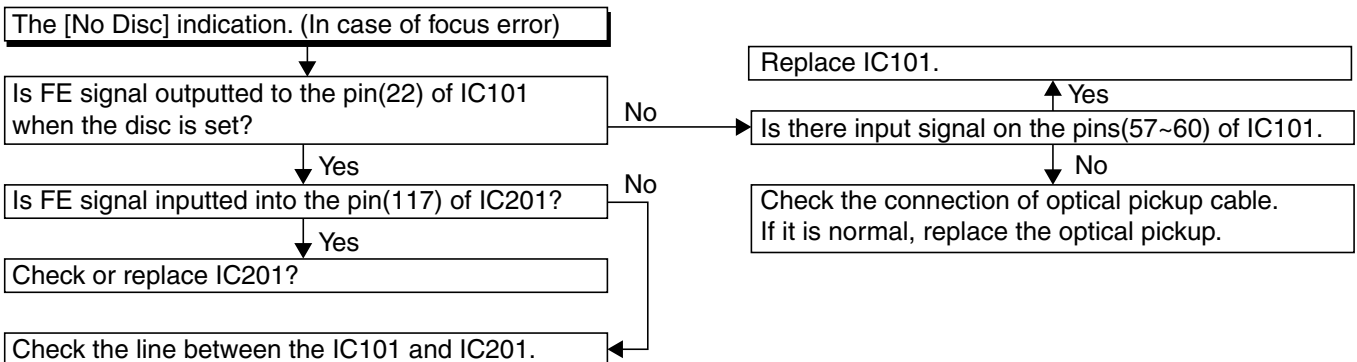

FLOW CHART NO.17

The [No Disc] indication. (In case focus servo does not function.)

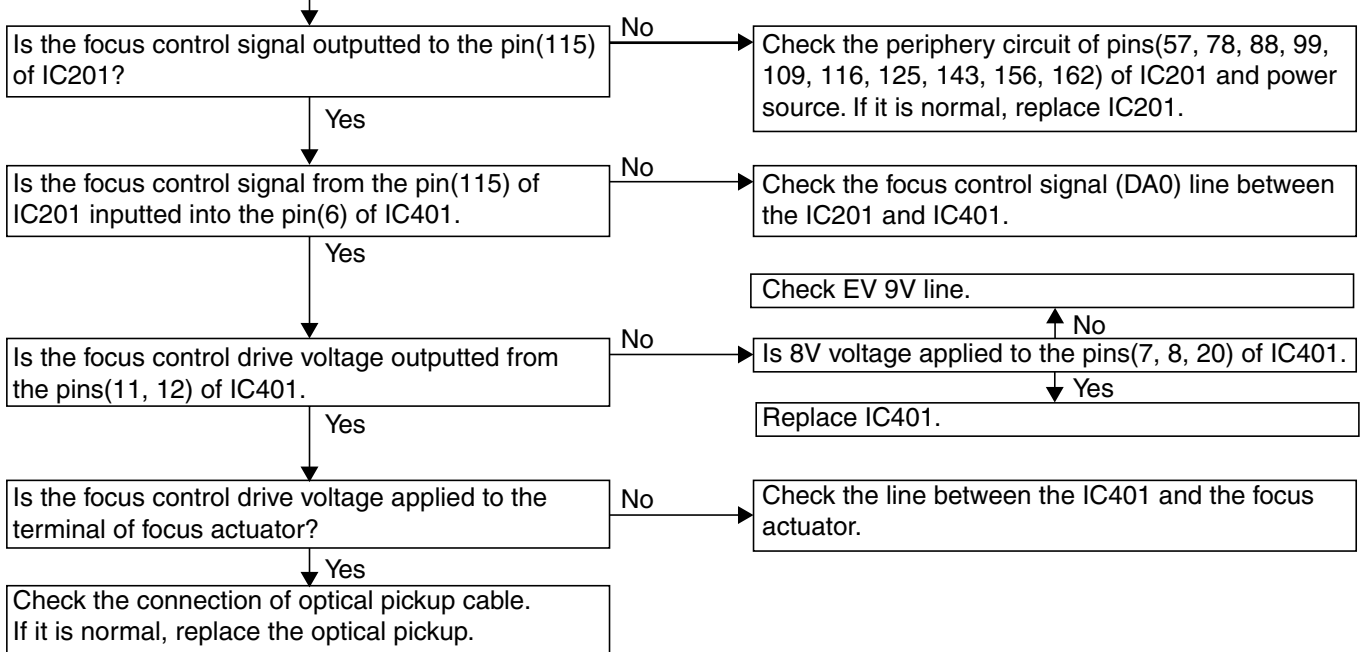

FLOW CHART NO.18

The [No Disc] indication. (When the laser beam does not light.)

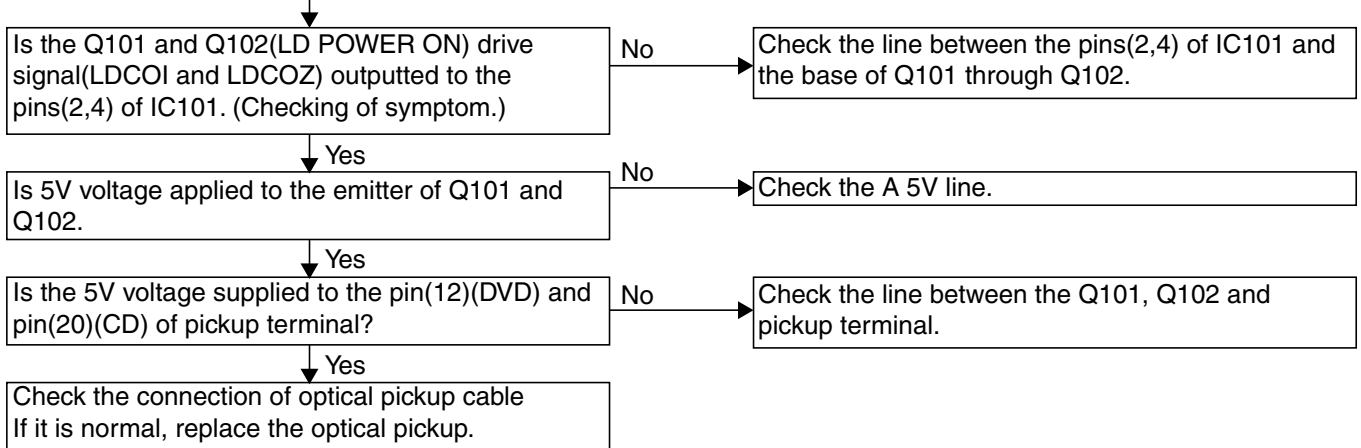

FLOW CHART NO.19

Both picture and sound do not operate normally.

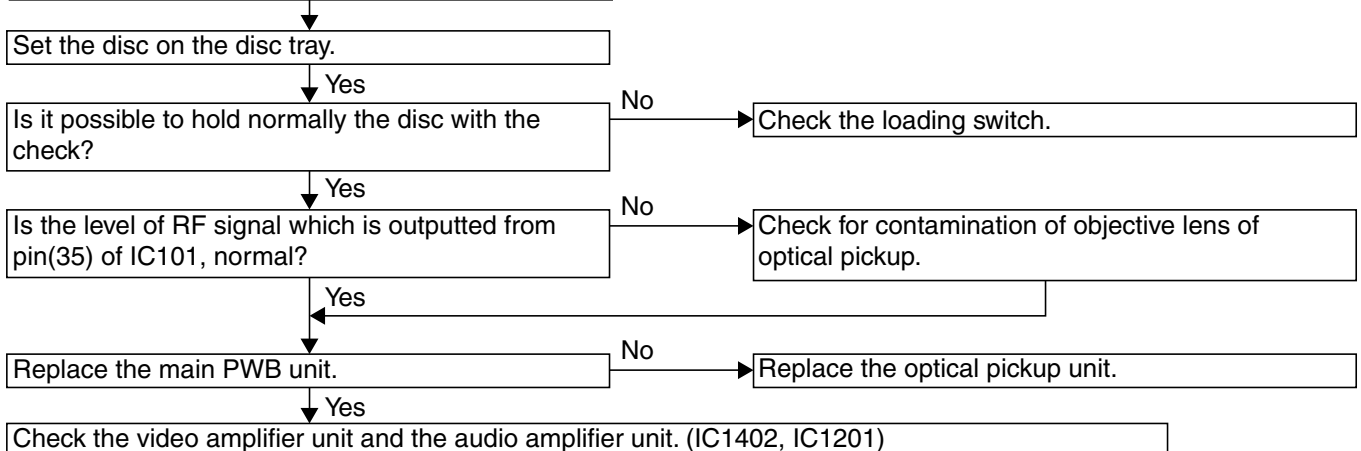

FLOW CHART NO.20

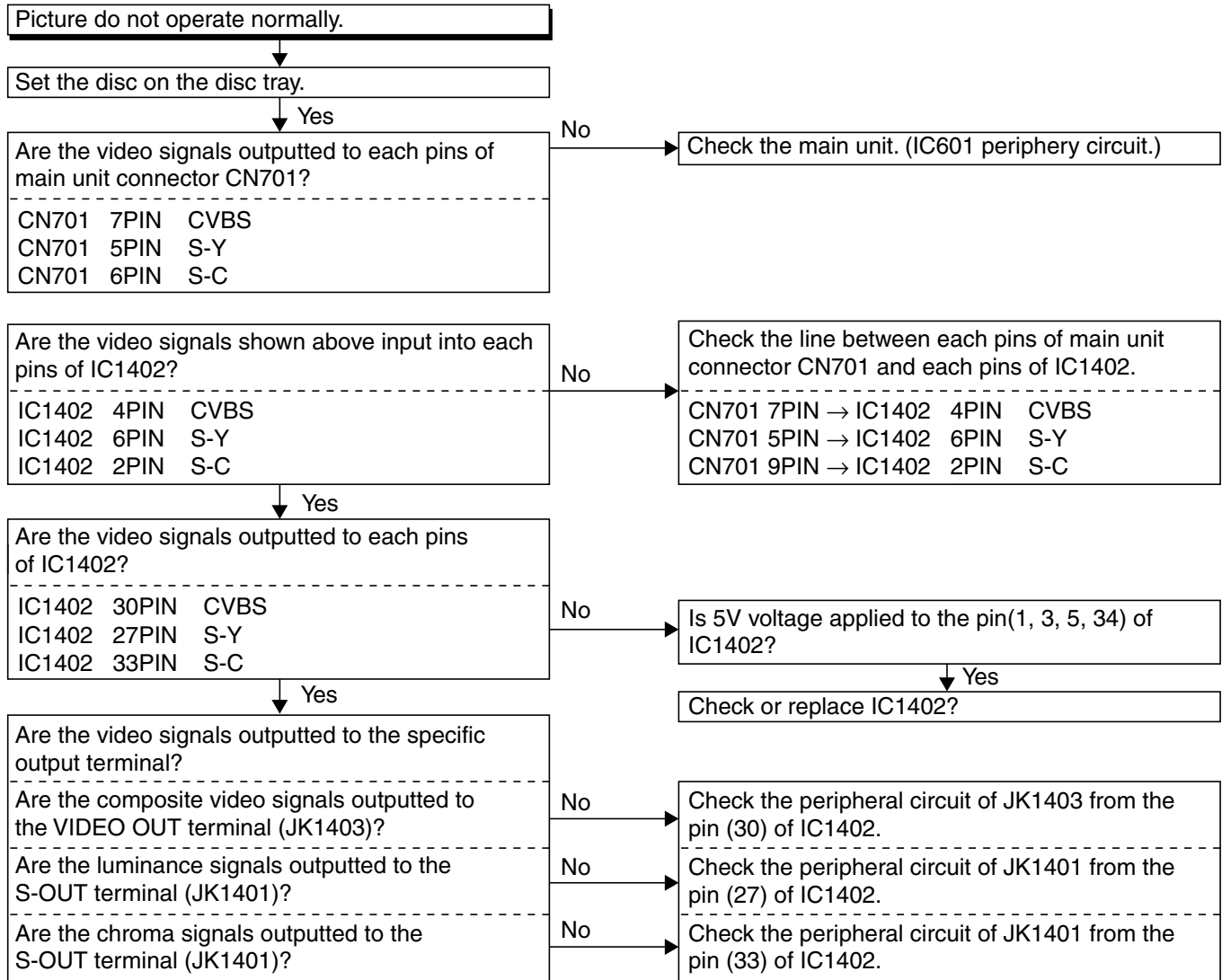

FLOW CHART NO.21

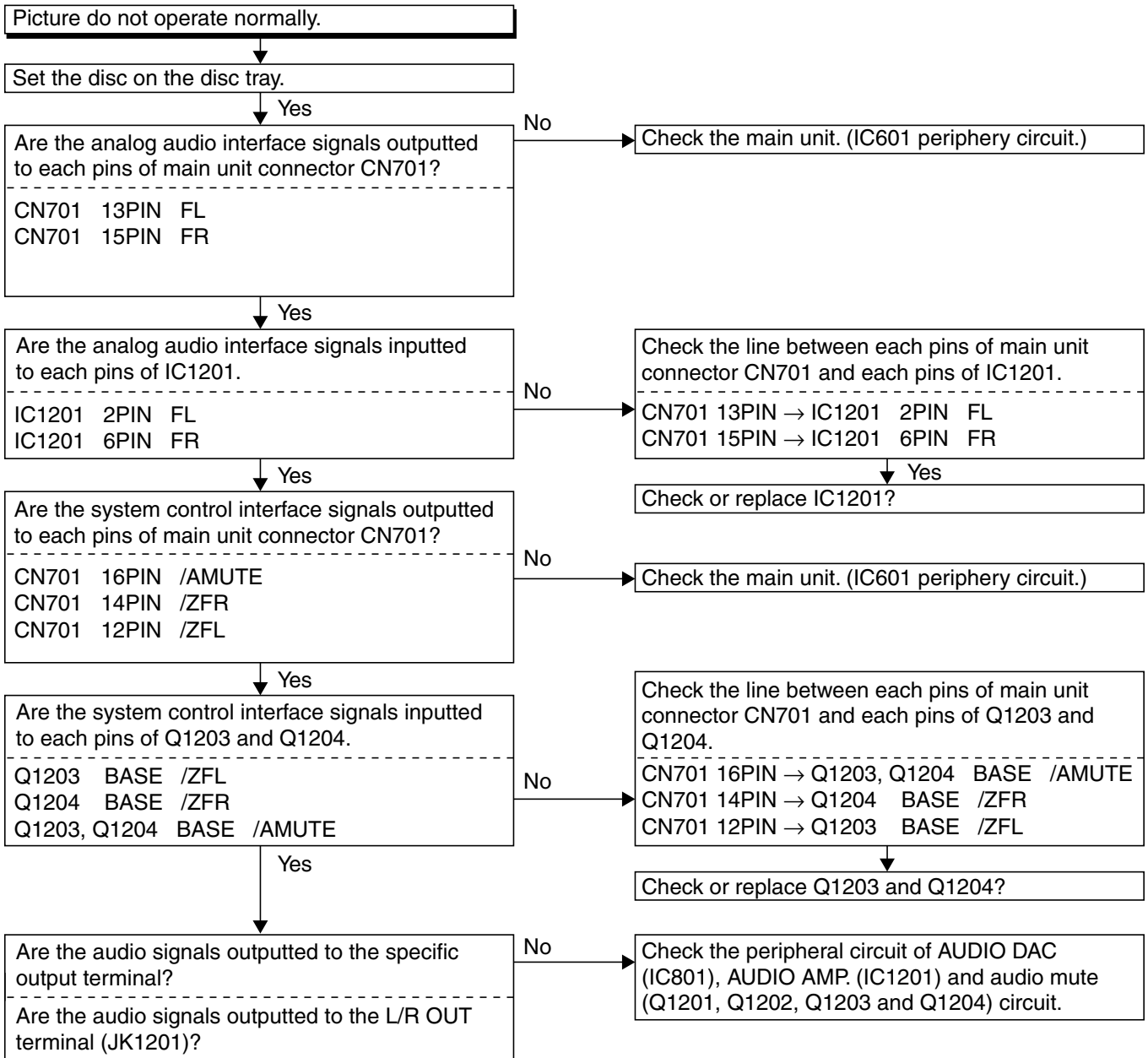

BLOCK DIAGRAMS

System Control Block Diagram

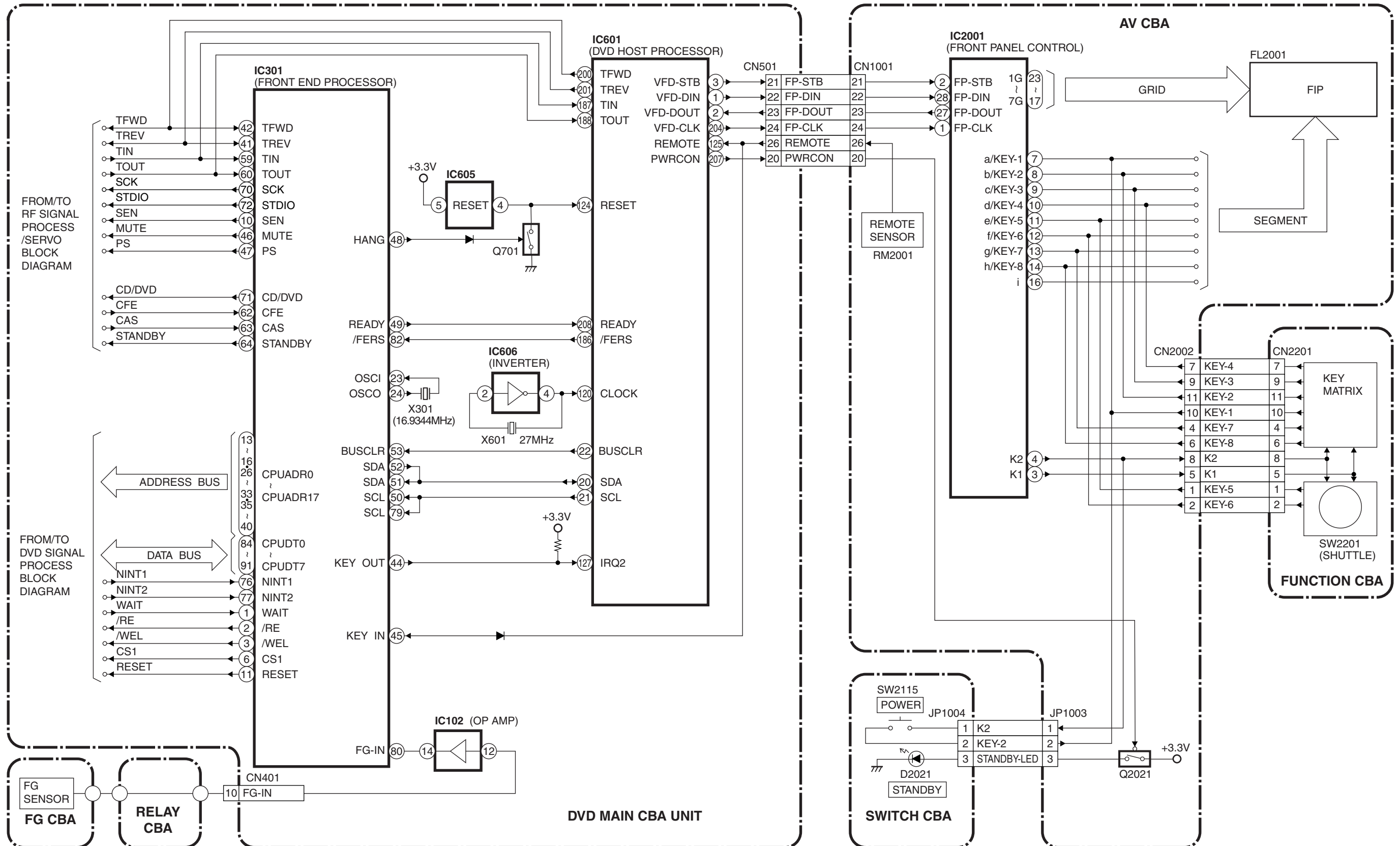

RF Signal Process/Servo Block Diagram

DATA(VIDEO/AUDIO) SIGNAL
 FOCUS SERVO SIGNAL
 TRACKING SERVO SIGNAL
 SLIDE SERVO SIGNAL
 DISK SERVO SIGNAL

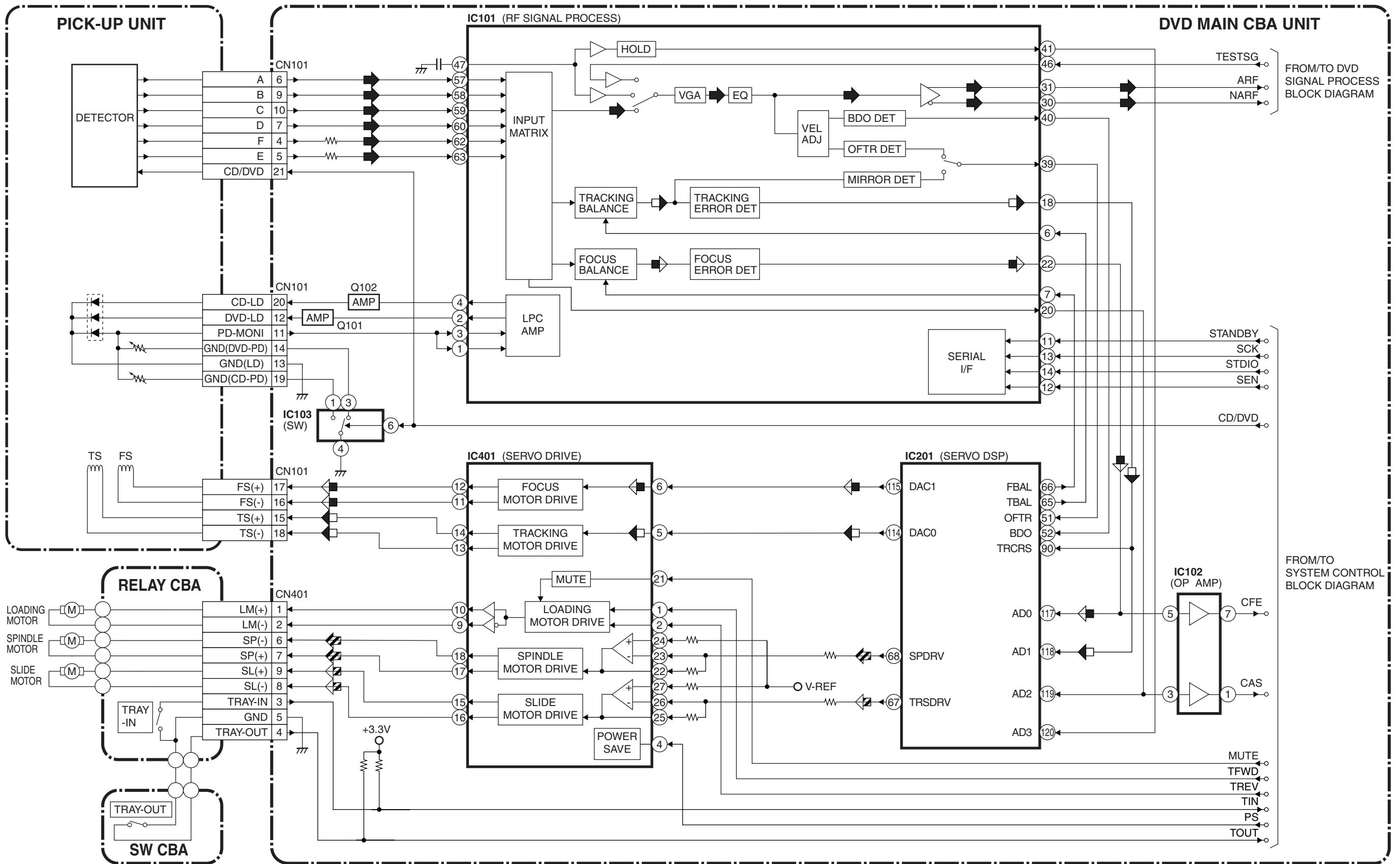

DVD Signal Process Block Diagram

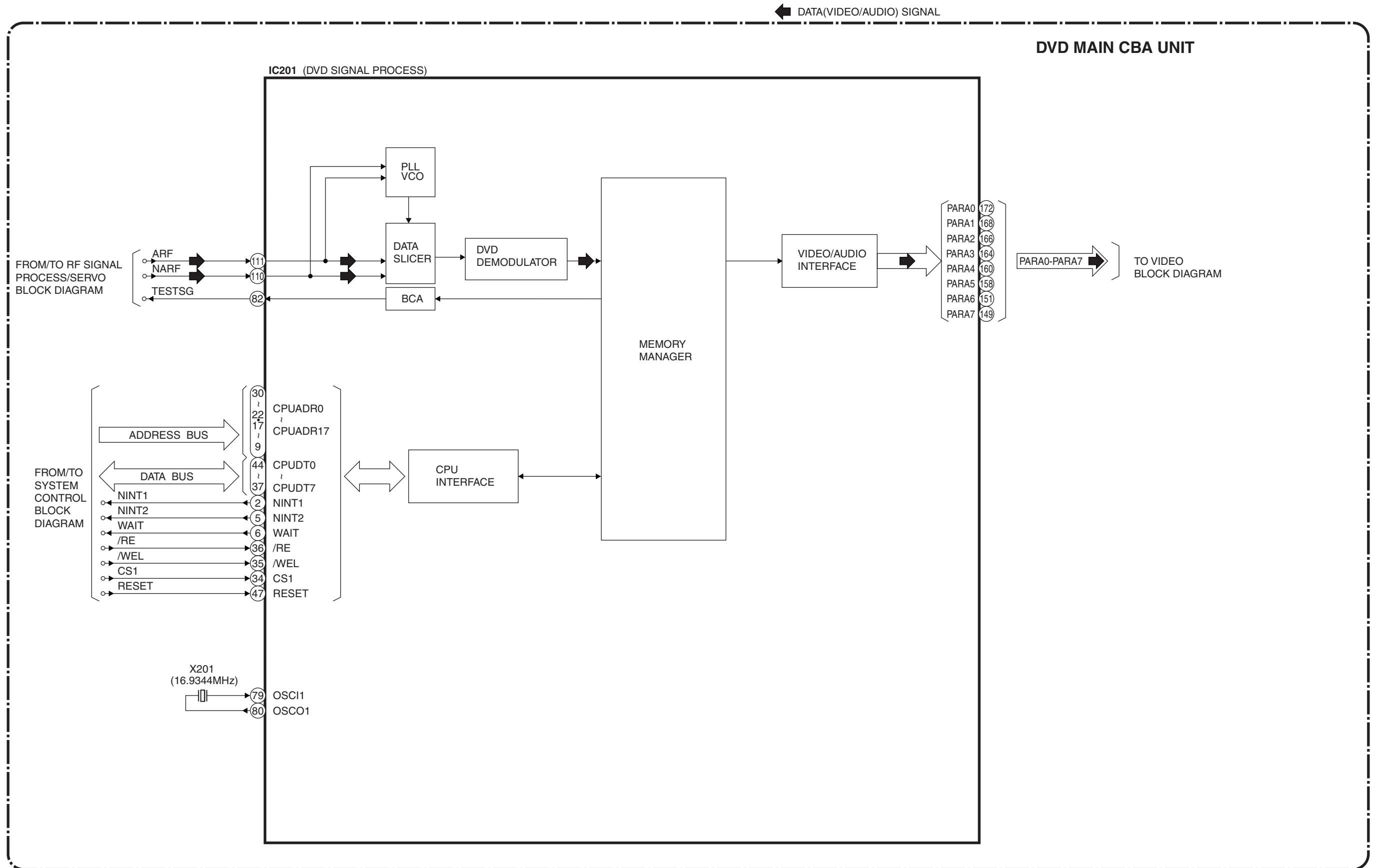

Video Block Diagram

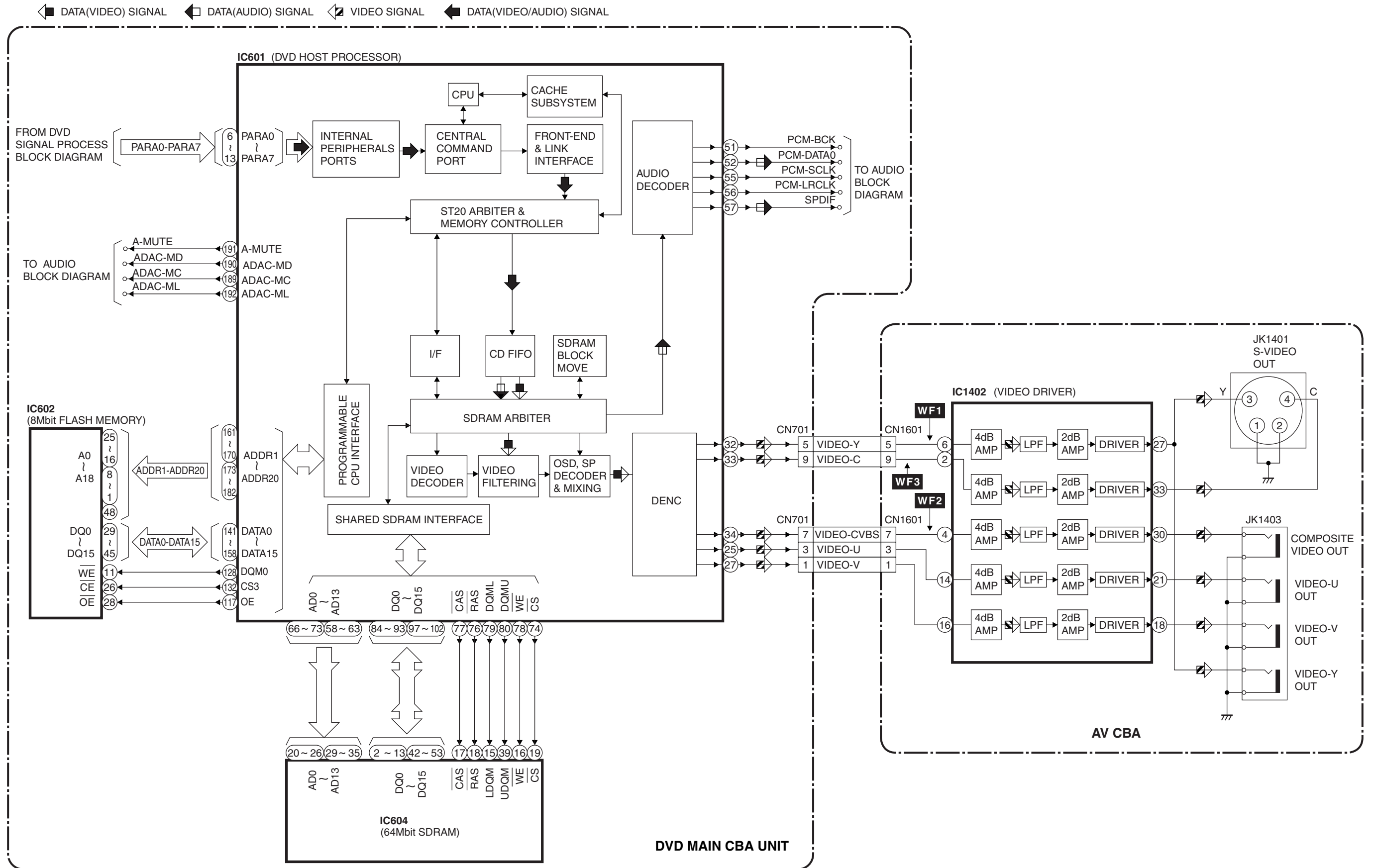

Audio Block Diagram

◻ DATA(AUDIO) SIGNAL ◻ AUDIO SIGNAL

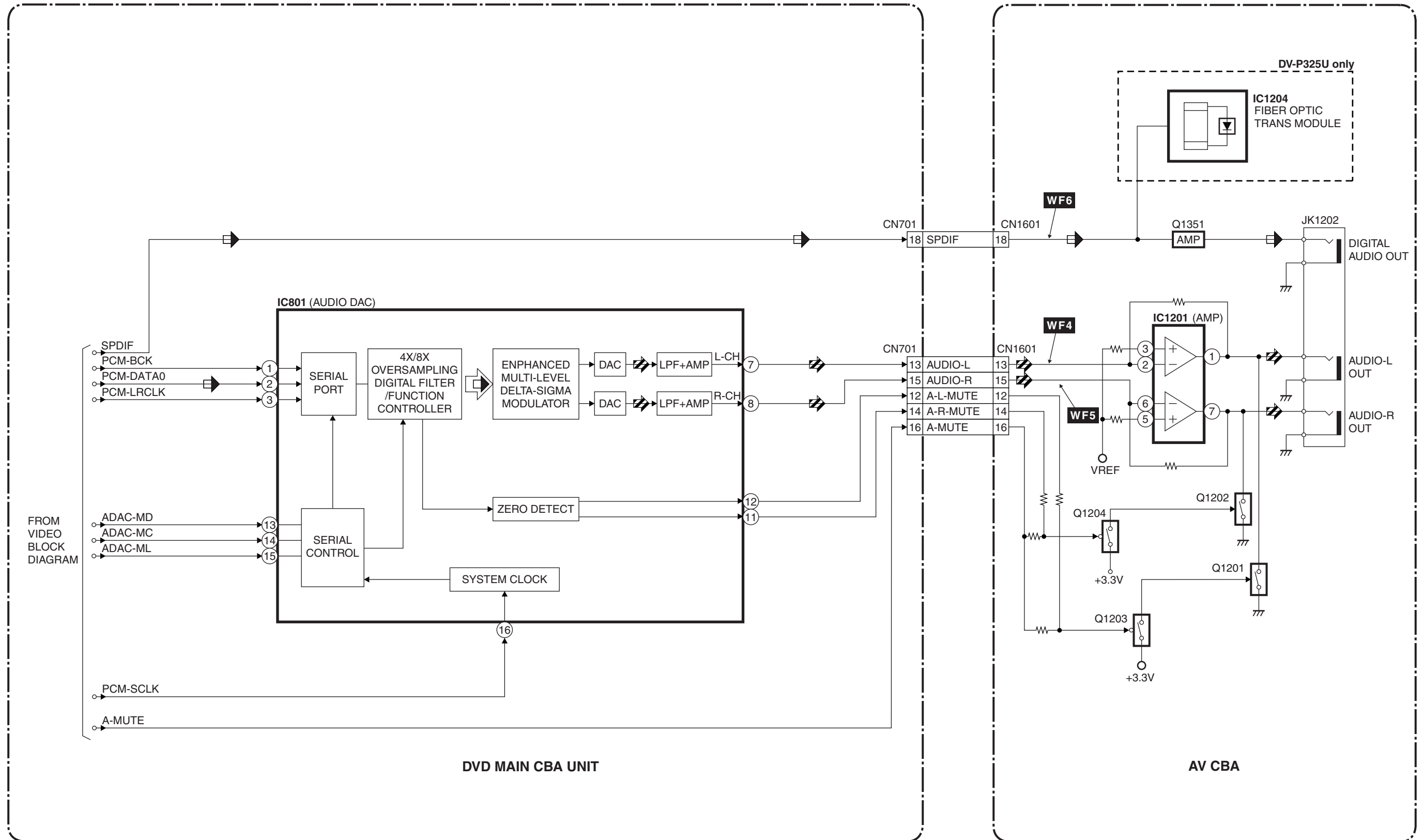

Power Supply Block Diagram

CAUTION !

Switching power supply circuit is used in this unit.
If Main Fuse (F1001) is blown, check to see that all components in the power supply circuit are not defective before you connect the AC plug to the AC power supply. Otherwise it may cause some components in the power supply circuit to fail.

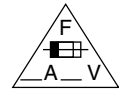

CAUTION

FOR CONTINUED PROTECTION AGAINST FIRE HAZARD,
REPLACE ONLY WITH THE SAME TYPE FUSE.
ATTENTION : POUR UNE PROTECTION CONTINUE LES RISQUES
D'INCELE N'UTILISER QUE DES FUSIBLE DE MEMO TYPE.
RISK OF FIRE -REPLACE FUSE AS MARKED.

■ "This symbol means fast operating fuse."
"Ce symbole représente un fusible à fusion rapide."

NOTE :

The voltage for parts in hot circuit is measured using hot GND as a common terminal.

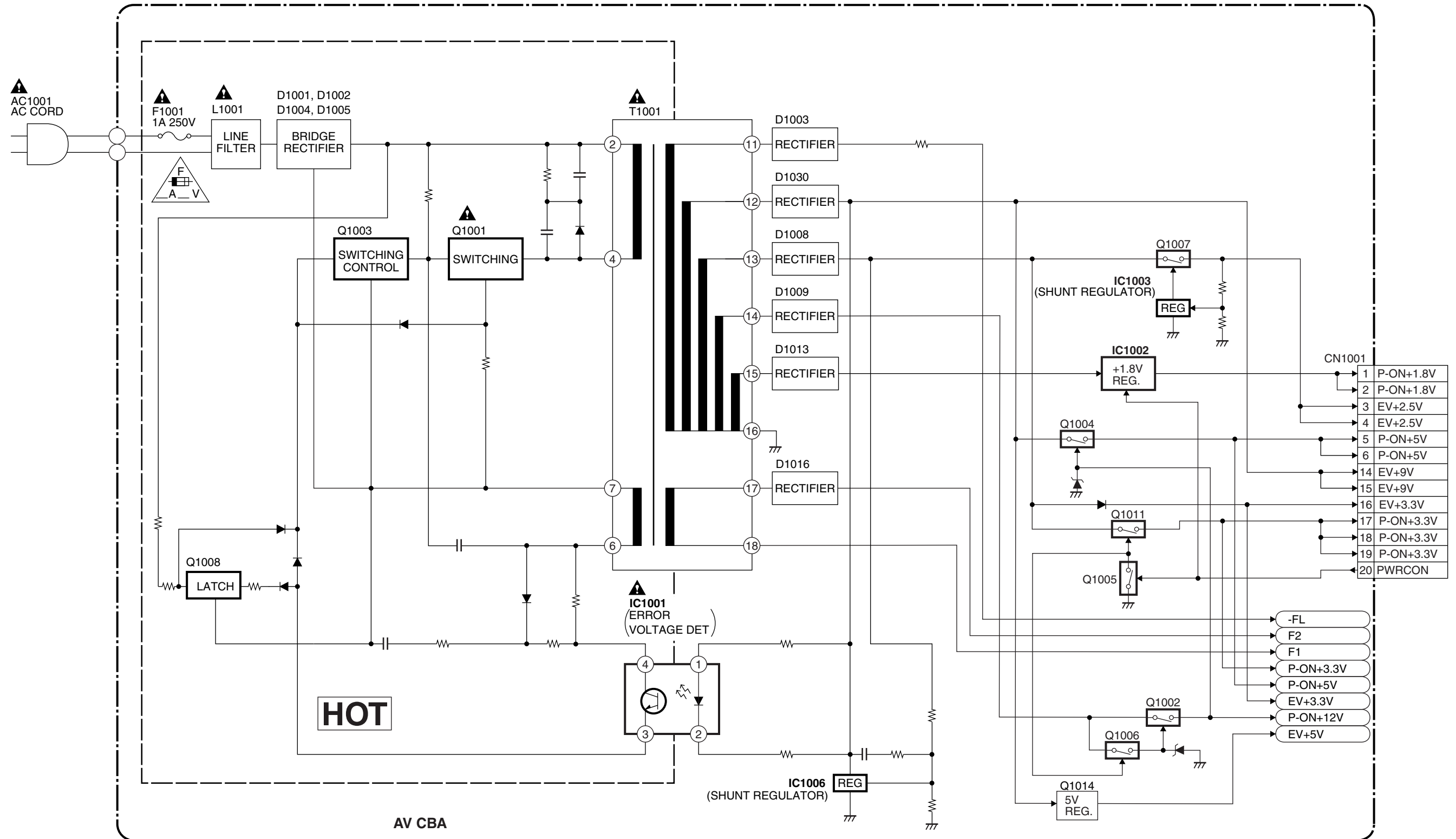

SCHEMATIC DIAGRAMS / CBA'S AND TEST POINTS

Standard Notes

WARNING

Many electrical and mechanical parts in this chassis have special characteristics. These characteristics often pass unnoticed and the protection afforded by them cannot necessarily be obtained by using replacement components rated for higher voltage, wattage, etc. Replacement parts that have these special safety characteristics are identified in this manual and its supplements; electrical components having such features are identified by the mark "▲" in the schematic diagram and the parts list. Before replacing any of these components, read the parts list in this manual carefully. The use of substitute replacement parts that do not have the same safety characteristics as specified in the parts list may create shock, fire, or other hazards.

Notes:

1. Do not use the part number shown on these drawings for ordering. The correct part number is shown in the parts list, and may be slightly different or amended since these drawings were prepared.
2. All resistance values are indicated in ohms ($K=10^3$, $M=10^6$).
3. Resistor wattages are 1/4W or 1/6W unless otherwise specified.
4. All capacitance values are indicated in μF ($P=10^{-6} \mu F$).
5. All voltages are DC voltages unless otherwise specified.

Capacitor Temperature Markings

Mark	Capacity change rate	Standard temperature	Temperature range
(B)	$\pm 10\%$	20°C	-25~+85°C
(F)	+30 - 80%	20°C	-25~+85°C
(SR)	$\pm 15\%$	20°C	-25~+85°C
(Z)	+30 - 80%	20°C	-10~+70°C

Capacitors and transistors are represented by the following symbols.

CBA Symbols

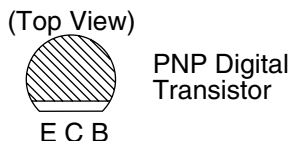
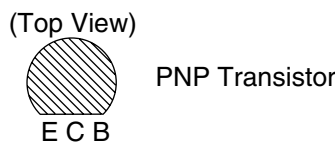
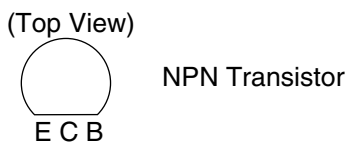
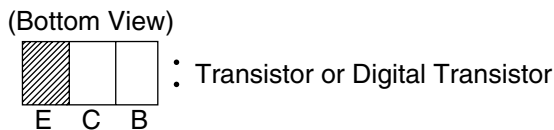
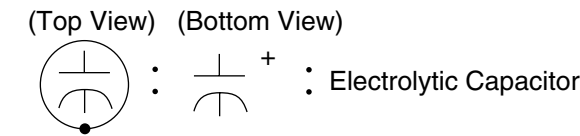

Schematic Diagram Symbols

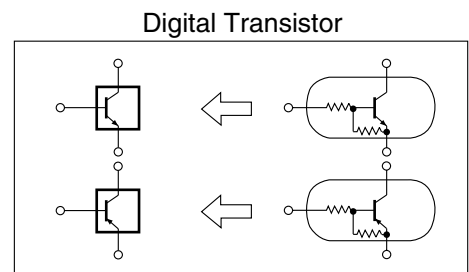

LIST OF CAUTION, NOTES, AND SYMBOLS USED IN THE SCHEMATIC DIAGRAMS ON THE FOLLOWING PAGES:

1. CAUTION:

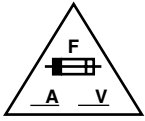

FOR CONTINUED PROTECTION AGAINST FIRE HAZARD, REPLACE ONLY WITH THE SAME TYPE FUSE.
 ATTENTION: POUR UNE PROTECTION CONTINUE LES RISQUES D'INCELE N'UTILISER QUE DES FUSIBLE DE MEMO TYPE.
 RISK OF FIRE-REPLACE FUSE AS MARKED.



This symbol means fast operating fuse.
 Ce symbole représente un fusible à fusion rapide.

2. CAUTION:

Fixed Voltage (or Auto voltage selectable) power supply circuit is used in this unit.
 If Main Fuse (F1001) is blown, first check to see that all components in the power supply circuit are not defective before you connect the AC plug to the AC power supply. Otherwise it may cause some components in the power supply circuit to fail.

3. Note:

- (1) Do not use the part number shown on the drawings for ordering. The correct part number is shown in the parts list, and may be slightly different or amended since the drawings were prepared.
- (2) To maintain original function and reliability of repaired units, use only original replacement parts which are listed with their part numbers in the parts list section of the service manual.

4. Wire Connectors

- (1) Prefix symbol "CN" means "connector" (can disconnect and reconnect).
- (2) Prefix symbol "CL" means "wire-solder holes of the PCB" (wire is soldered directly).

5. Mode: SP

6. Voltage indications for PLAY mode on the schematics are as shown below:

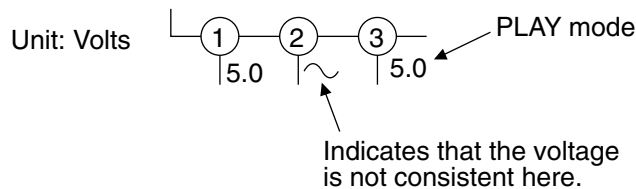

7. How to read converged lines

1-D3
 ↑ Distinction Area
 ↑ Line Number
 (1 to 3 digits)

Examples:

1. "1-D3" means that line number "1" goes to area "D3".
2. "1-B1" means that line number "1" goes to area "B1".

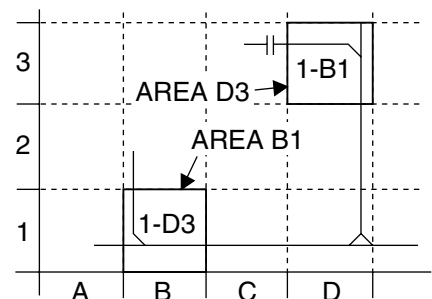

8. Test Point Information

- ⊙ : Indicates a test point with a jumper wire across a hole in the PCB.
- : Used to indicate a test point with a component lead on foil side.
- ⊘ : Used to indicate a test point with no test pin.
- : Used to indicate a test point with a test pin.

DVD Main 1/4 Schematic Diagram

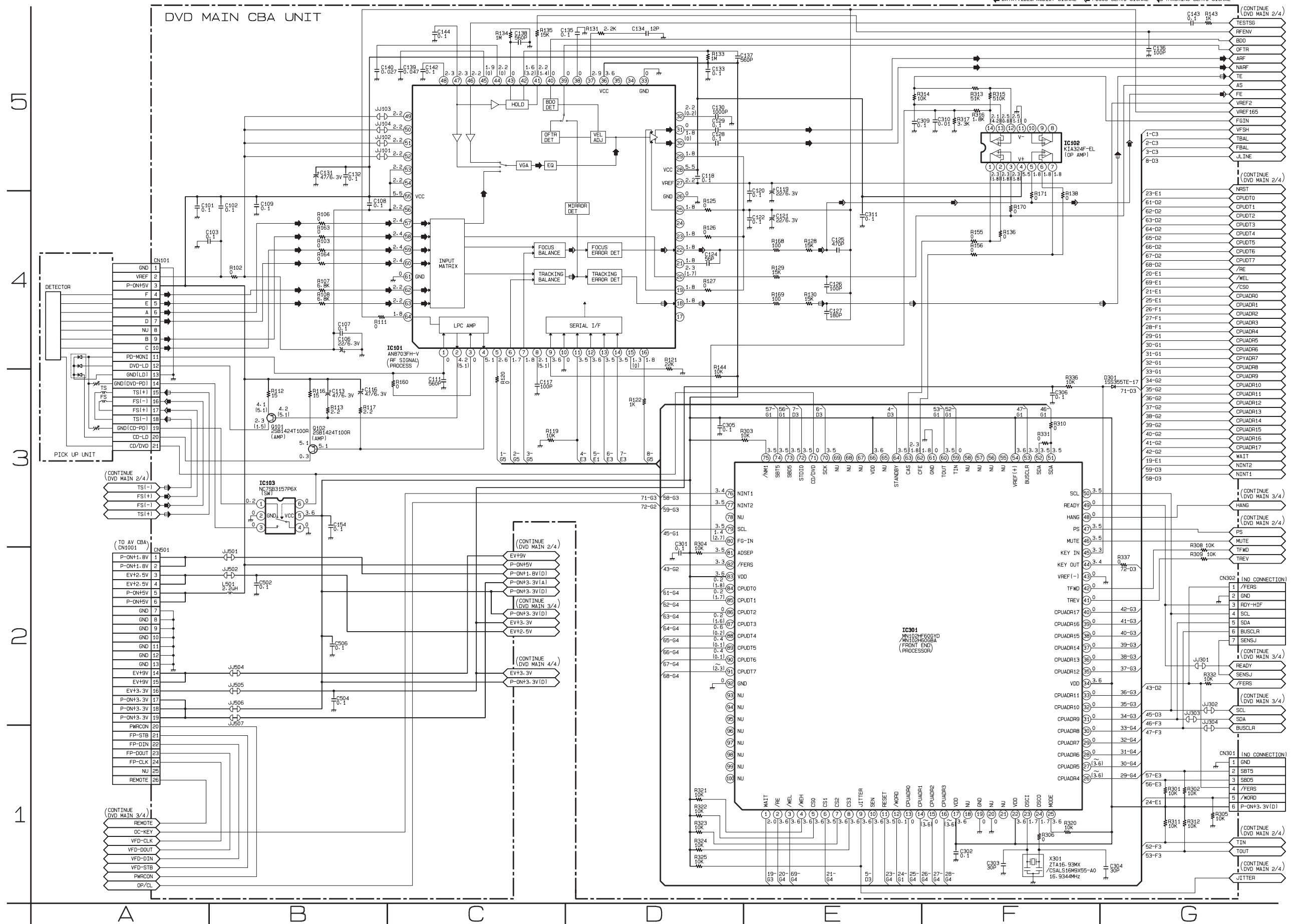

DVD Main 2/4 Schematic Diagram

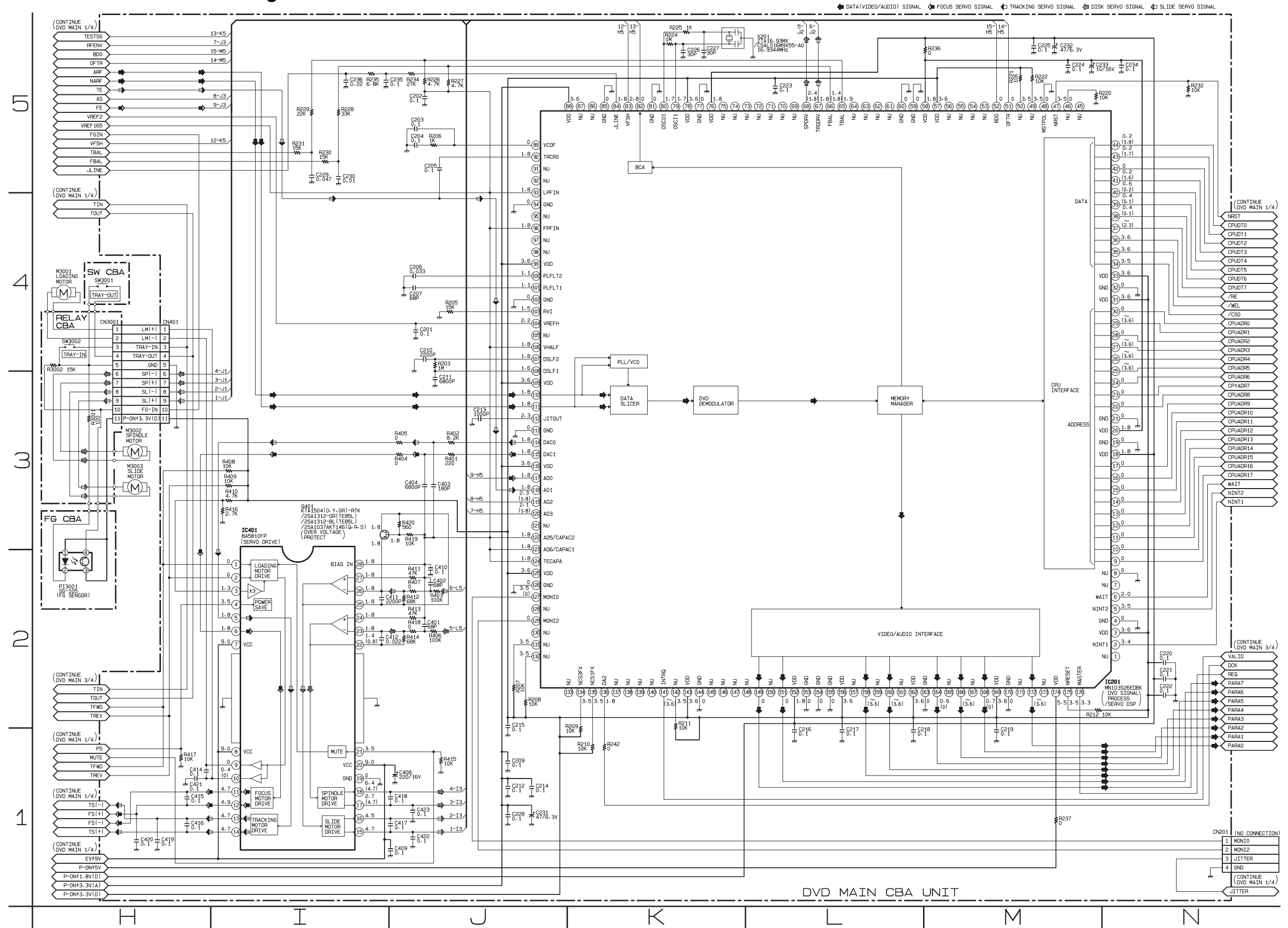

DVD MAIN CBA UNIT

DVD Main 3/4 Schematic Diagram

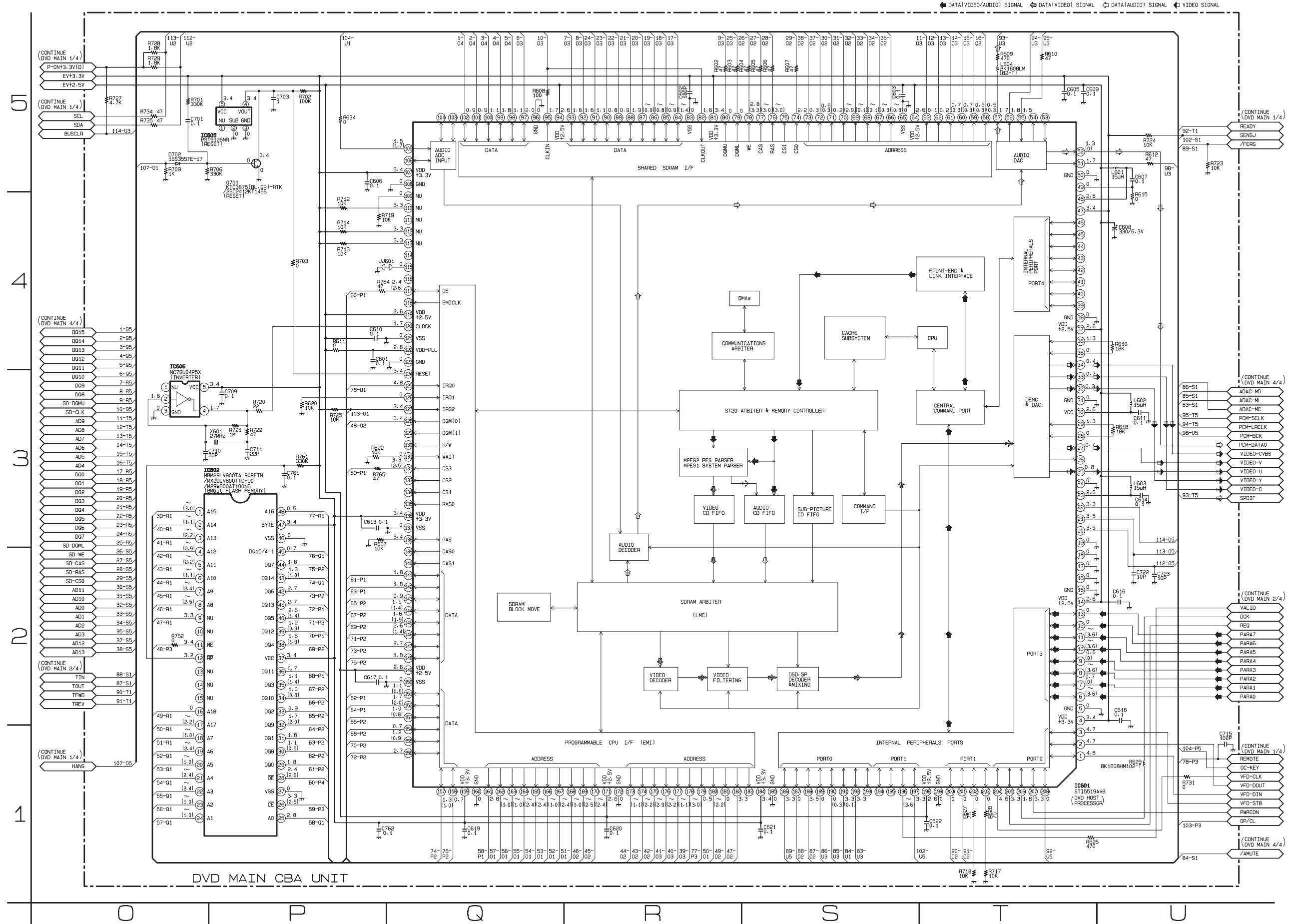

AV 1/3 Schematic Diagram

CAUTION !

Fixed voltage power supply circuit is used in this unit.
If Main Fuse (F1001) is blown, check to see that all components in the power supply circuit are not defective before you connect the AC plug to the AC power supply. Otherwise it may cause some components in the power supply circuit to fail.

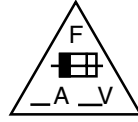

CAUTION

FOR CONTINUED PROTECTION AGAINST FIRE HAZARD,
REPLACE ONLY WITH THE SAME TYPE FUSE.
ATTENTION : POUR UNE PROTECTION CONTINUE LES RISQUES
D'INCELE N'UTILISER QUE DES FUSIBLE DE MEMO TYPE.
RISK OF FIRE-REPLACE FUSE AS MARKED.



"This symbol means fast operating fuse."

"Ce symbole représente un fusible à fusion rapide."

NOTE :

The voltage for parts in hot circuit is measured using hot GND as a common terminal.

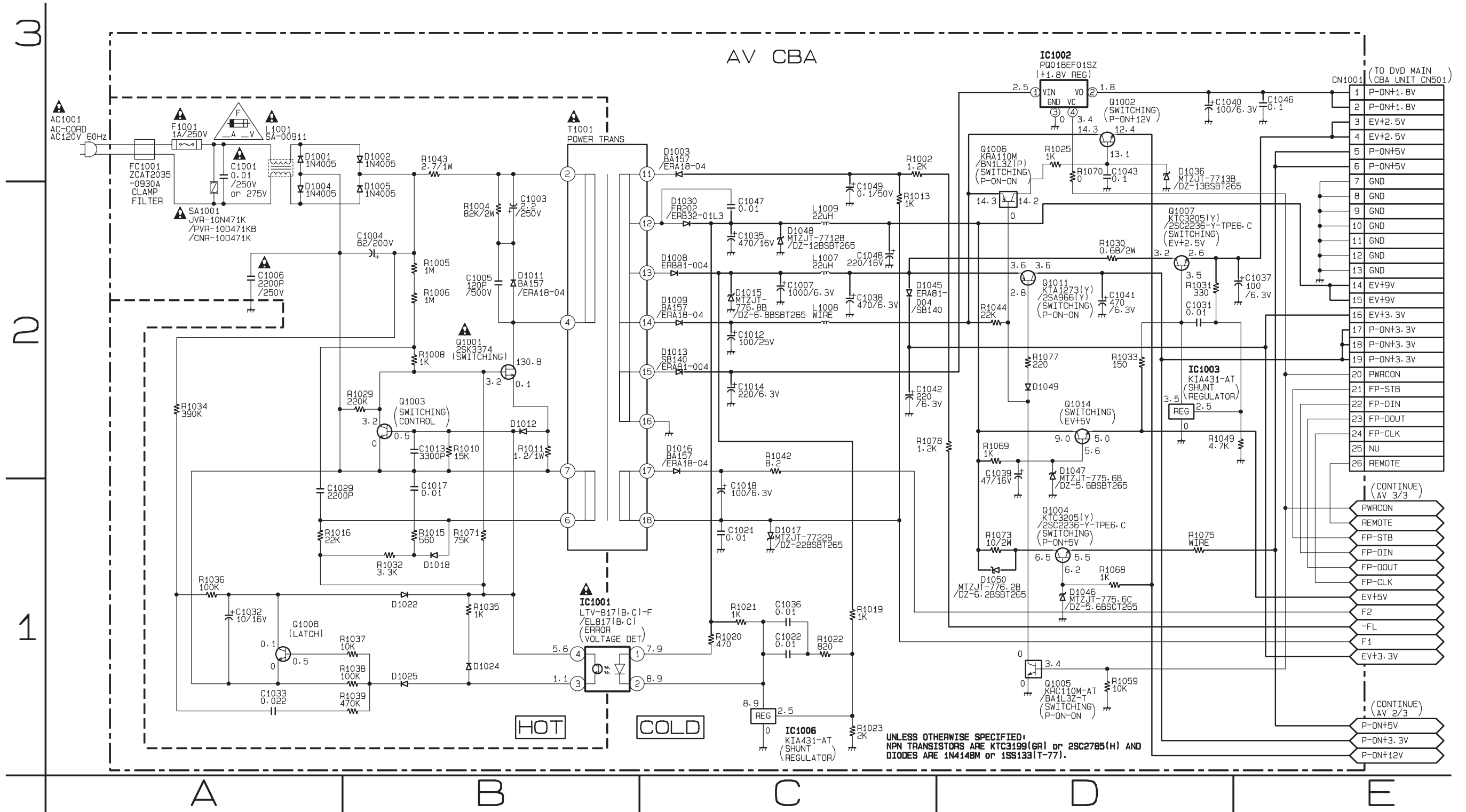

AV 2/3 Schematic Diagram

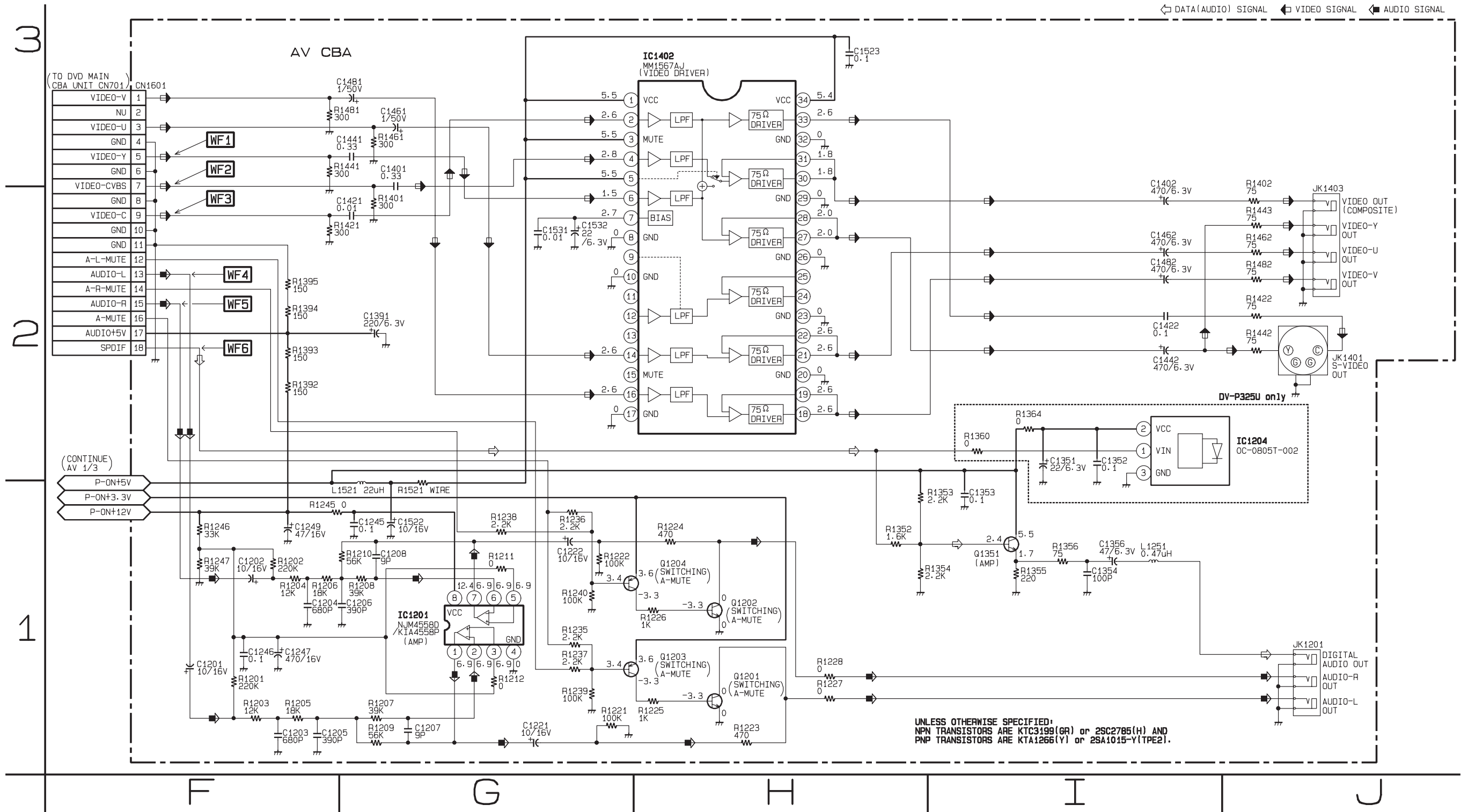

WAVEFORMS

WF1 Pin 5 of CN1601

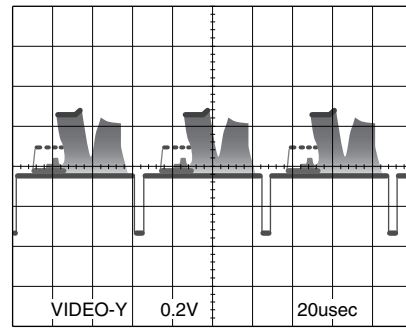

WF5 Pin 15 of CN1601

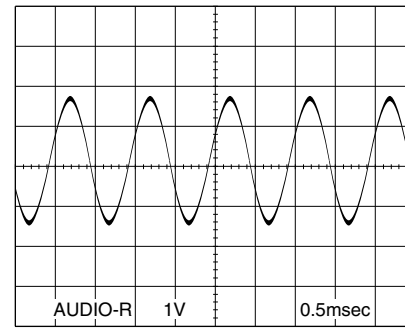

WF2 Pin 7 of CN1601

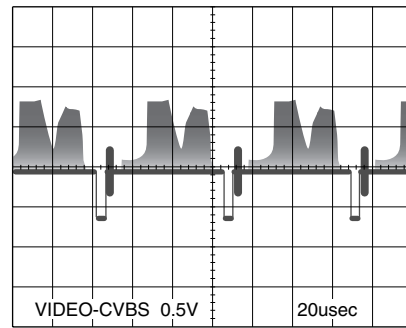

WF6 Pin 18 of CN1601

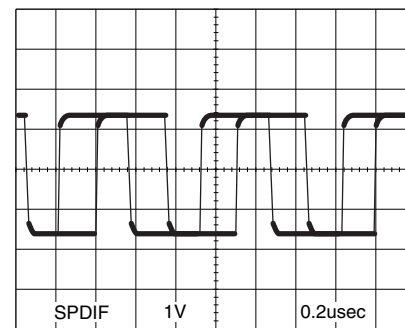

WF3 Pin 9 of CN1601

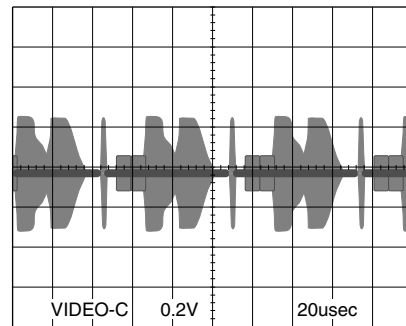

NOTE:

Input

CD: 1kHz PLAY
(WF4~WF6)

DVD: POWER ON (STOP) MODE
(WF1~WF3)

WF4 Pin 13 of CN1601

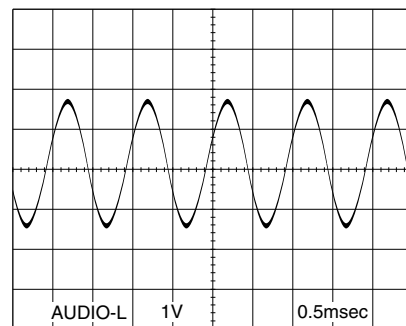

AV 3/3, Function & Switch Schematic Diagram

FL2001 MATRIX CHART

	7G	6G	5G	4G	3G	2G	1G
a	STANDBY	a	a	a	a	a	①
b	REPEAT	b	b	b	b	b	②
c	A	c	c	c	c	c	③
d	-B	d	d	d	d	d	④
e	▶	e	e	e	e	e	⑤
f	⏸	f	f	f	f	f	DVD
g	—	g	g	g	g	g	PBC
h	⏏	⏏	TITLE	⏏	CHP.	TRK.	CD
i	—	—	□	—	—	—	V

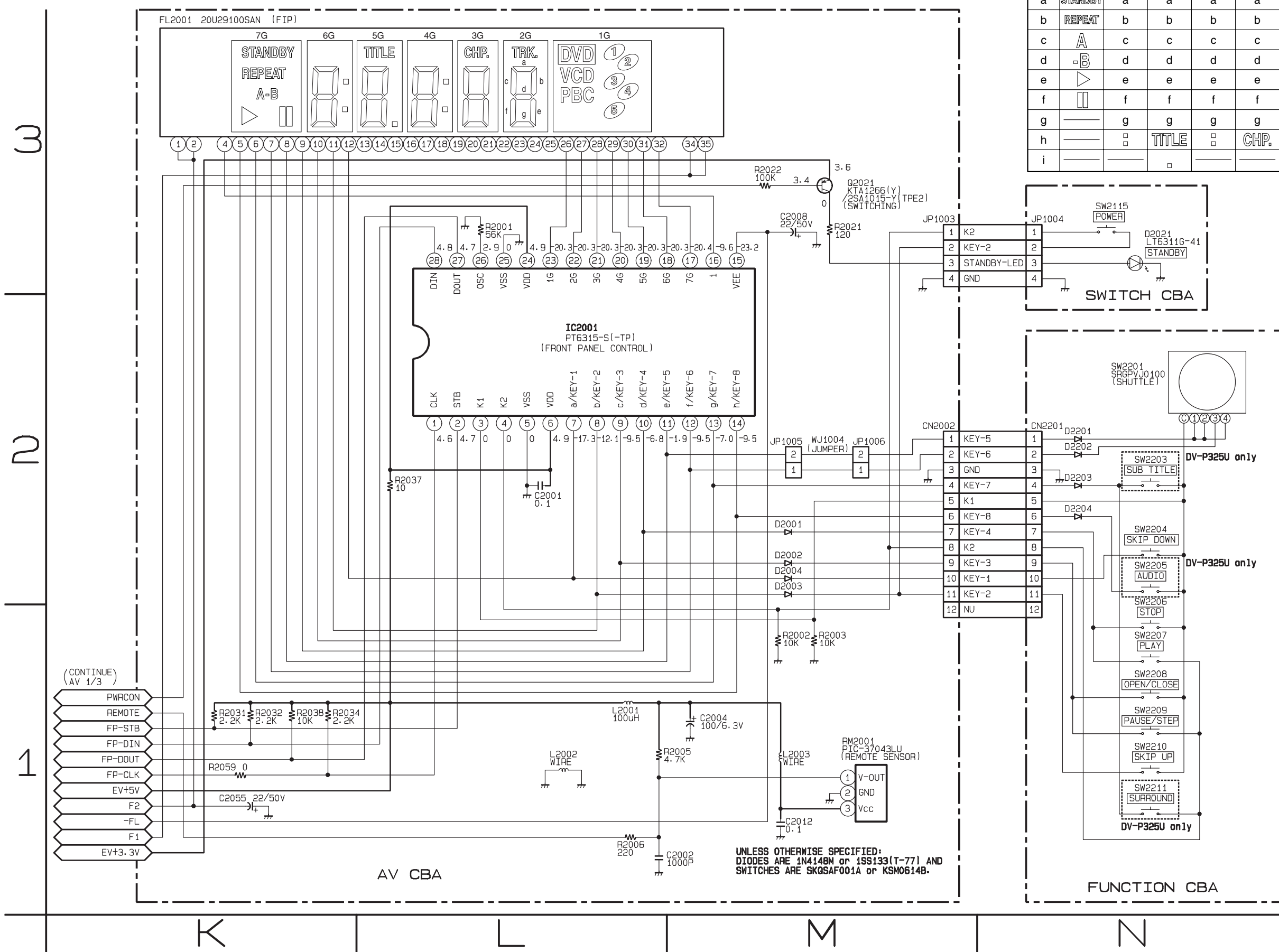

UNLESS OTHERWISE SPECIFIED:
 DIODES ARE 1N4148M or 1SS133(T-77) AND
 SWITCHES ARE SKQSAF001A or KSM0614B.

AV CBA Top View

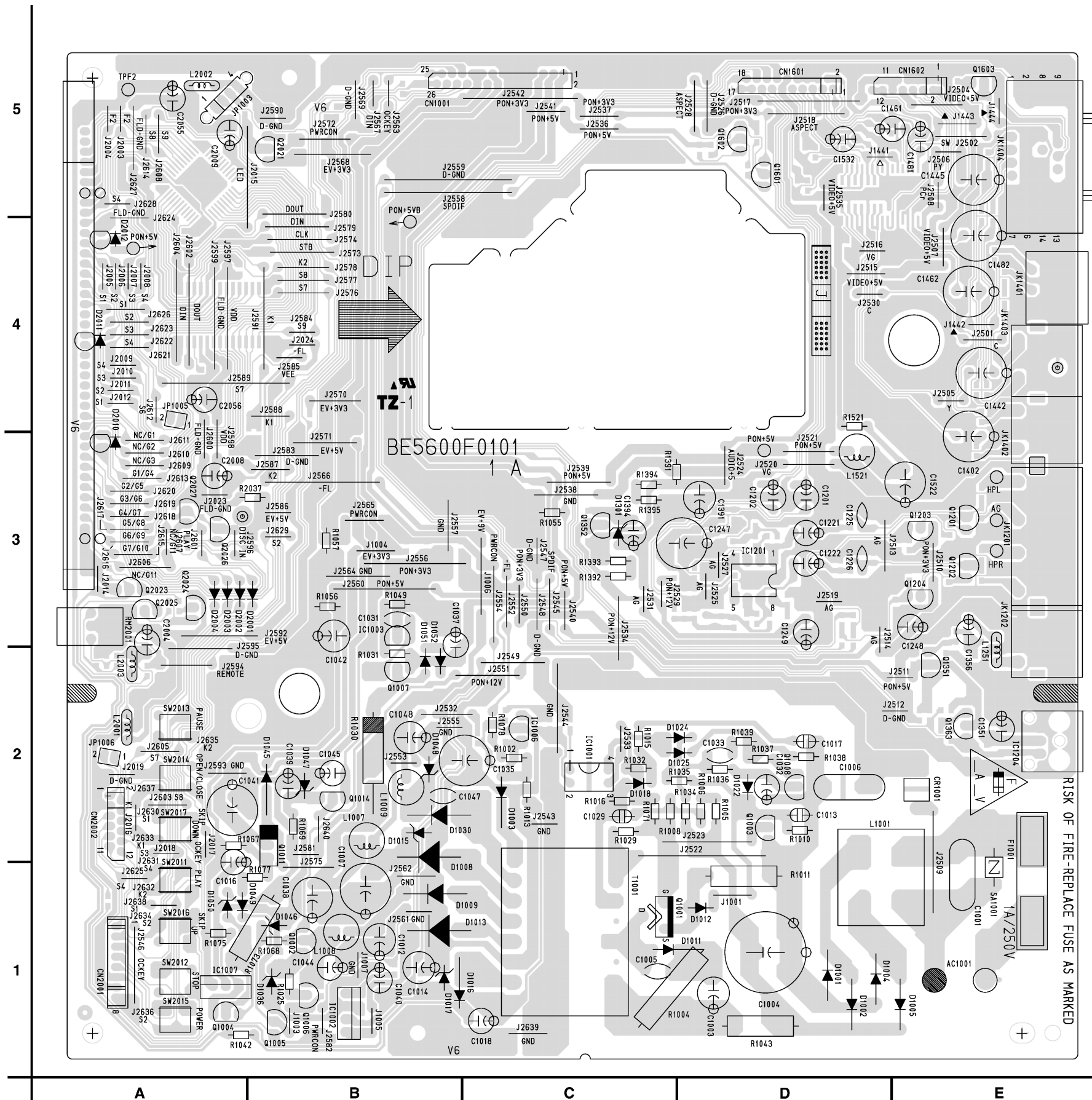

CAUTION !

Switching power supply circuit is used in this unit.
If Main Fuse (F1001) is blown, check to see that all components in the power supply circuit are not defective before you connect the AC plug to the AC power supply. Otherwise it may cause some components in the power supply circuit to fail.

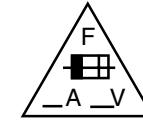

CAUTION

FOR CONTINUED PROTECTION AGAINST FIRE HAZARD,
REPLACE ONLY WITH THE SAME TYPE FUSE.
ATTENTION : POUR UNE PROTECTION CONTINUE LES RISQUES
D'INCELE N'UTILISER QUE DES FUSIBLE DE MEMO TYPE.
RISK OF FIRE-REPLACE FUSE AS MARKED.

 "This symbol means fast operating fuse."
"Ce symbole représente un fusible à fusion rapide."

BECAUSE A HOT CHASSIS GROUND IS PRESENT IN THE POWER SUPPLY CIRCUIT, AN ISOLATION TRANSFORMER MUST BE USED. ALSO, IN ORDER TO HAVE THE ABILITY TO INCREASE THE INPUT SLOWLY, WHEN TROUBLESHOOTING THIS TYPE POWER SUPPLY CIRCUIT, A VARIABLE ISOLATION TRANSFORMER IS REQUIRED.

AV CBA Bottom View

WF1 PIN 5 OF CN1601
WF2 PIN 7 OF CN1601
WF3 PIN 9 OF CN1601
WF4 PIN 13 OF CN1601
WF5 PIN 15 OF CN1601
WF6 PIN 18 OF CN1601

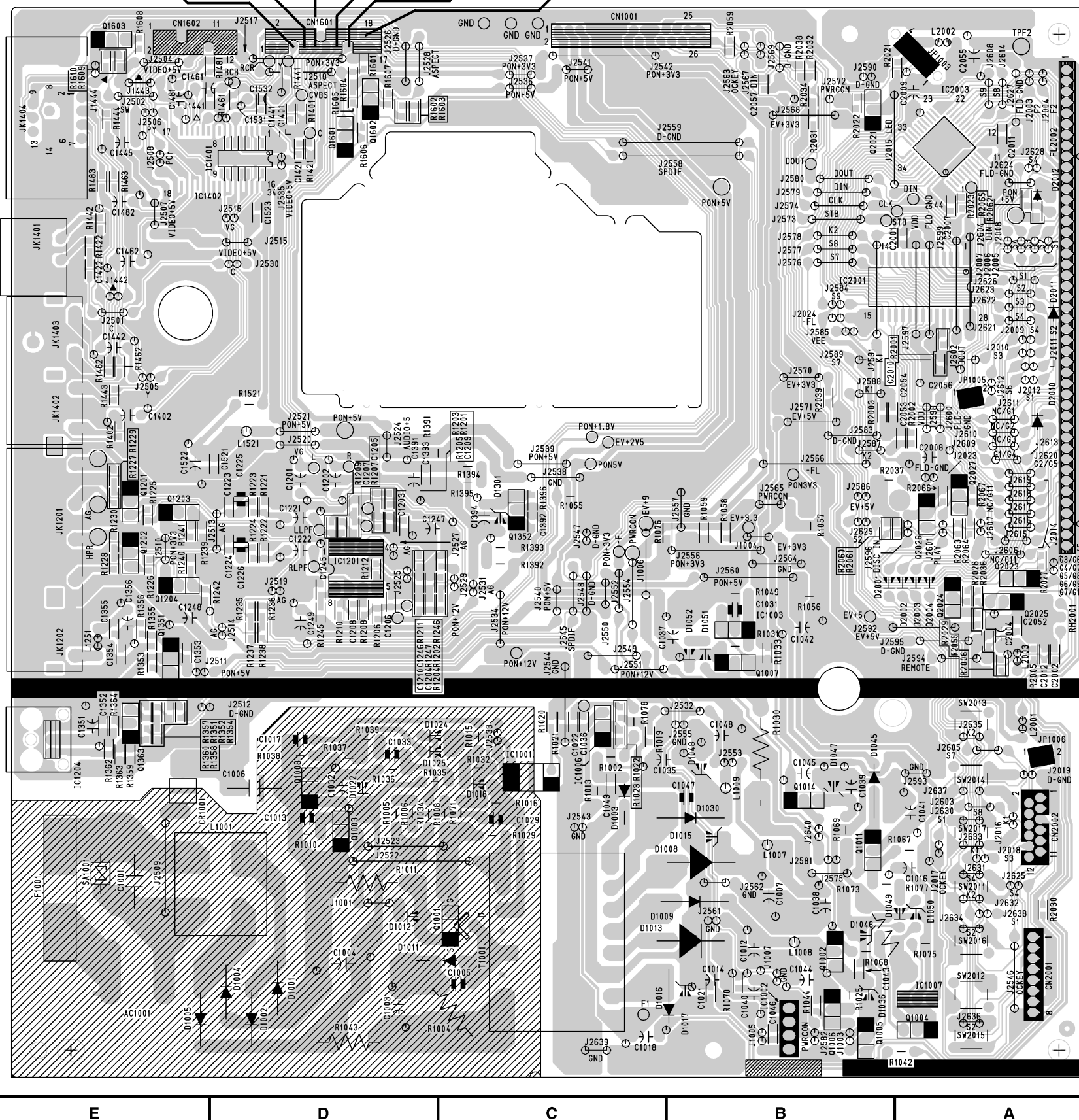

CAUTION !
 Switching power supply circuit is used in this unit.
 If Main Fuse (F1001) is blown, check to see that all components in the power supply circuit are not defective before you connect the AC plug to the AC power supply. Otherwise it may cause some components in the power supply circuit to fail.

CAUTION
 FOR CONTINUED PROTECTION AGAINST FIRE HAZARD, REPLACE ONLY WITH THE SAME TYPE FUSE.
 ATTENTION : POUR UNE PROTECTION CONTINUE LES RISQUES D'INCELE N'UTILISER QUE DES FUSIBLE DE MEMO TYPE.
RISK OF FIRE-REPLACE FUSE AS MARKED.

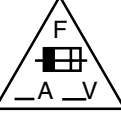
 "This symbol means fast operating fuse."
 "Ce symbole représente un fusible à fusion rapide."

BECAUSE A HOT CHASSIS GROUND IS PRESENT IN THE POWER SUPPLY CIRCUIT, AN ISOLATION TRANSFORMER MUST BE USED. ALSO, IN ORDER TO HAVE THE ABILITY TO INCREASE THE INPUT SLOWLY, WHEN TROUBLESHOOTING THIS TYPE POWER SUPPLY CIRCUIT, A VARIABLE ISOLATION TRANSFORMER IS REQUIRED.

Function CBA Top View

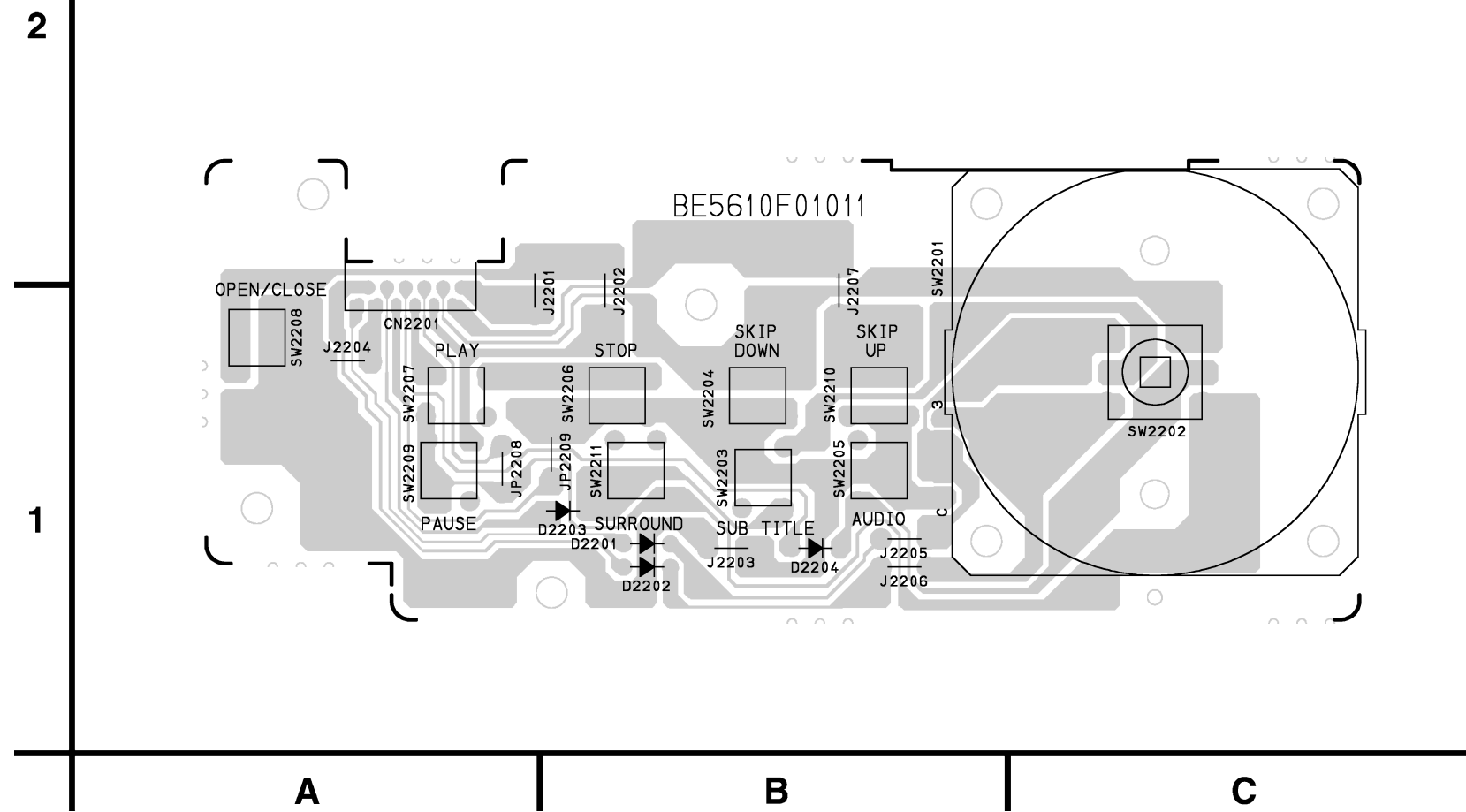

Switch CBA Top View Switch CBA Bottom View

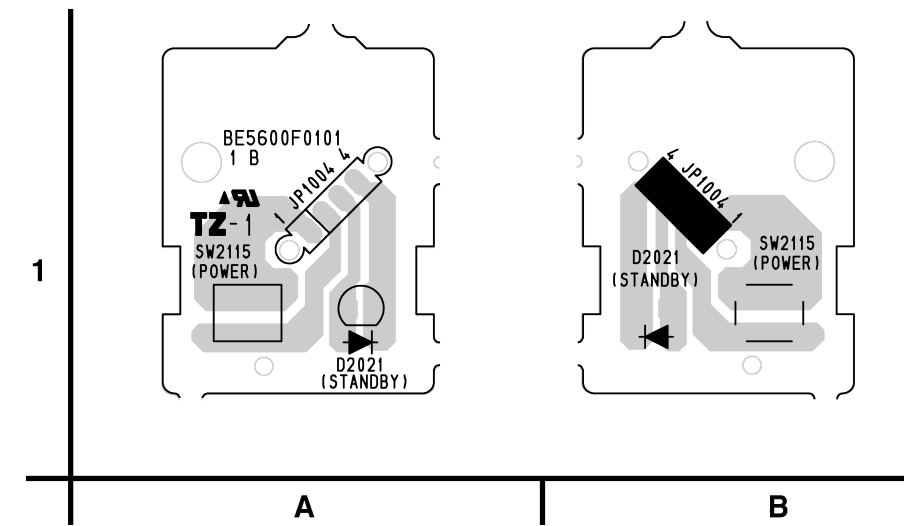

Function CBA Bottom View

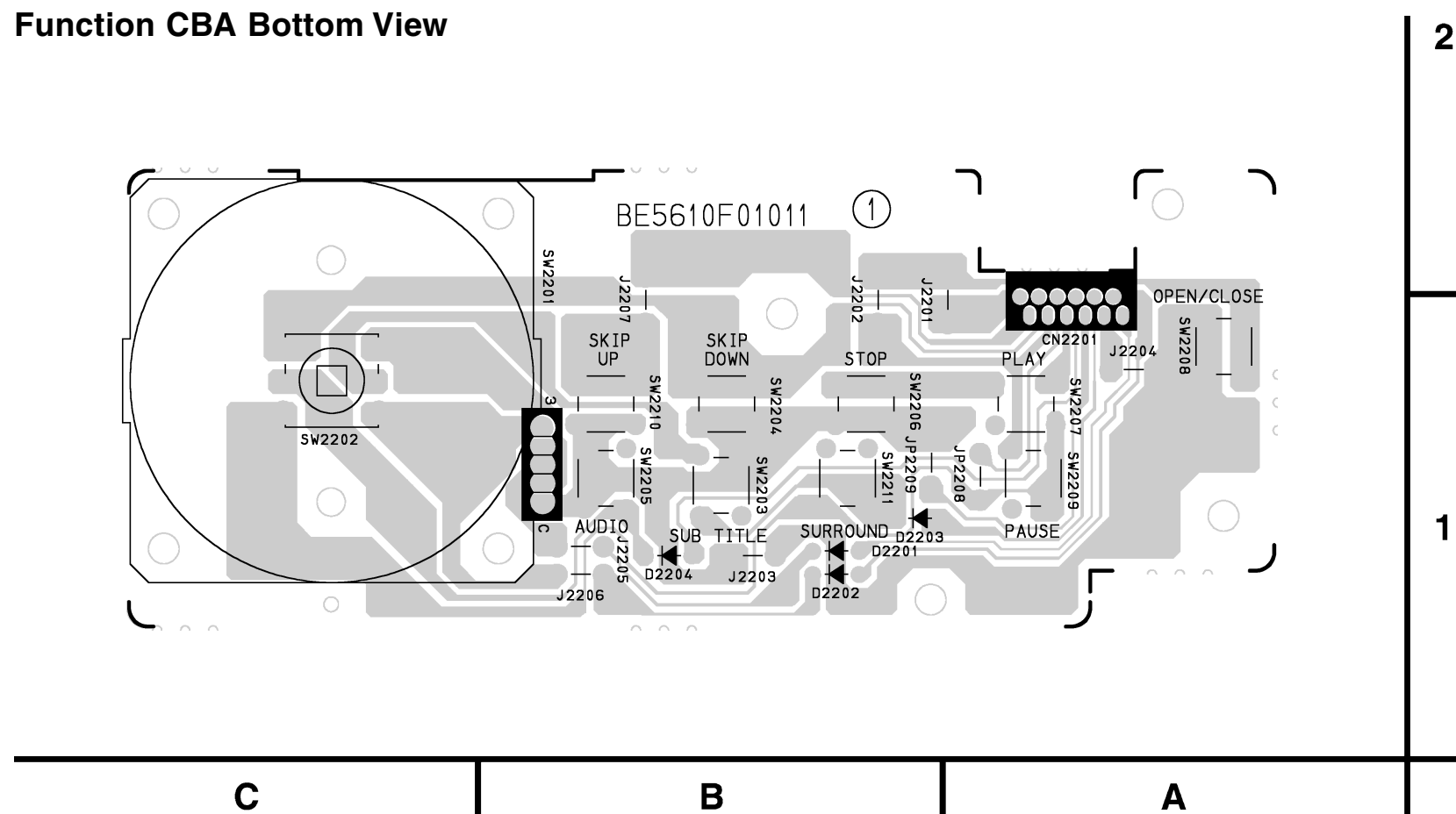

WIRING DIAGRAM

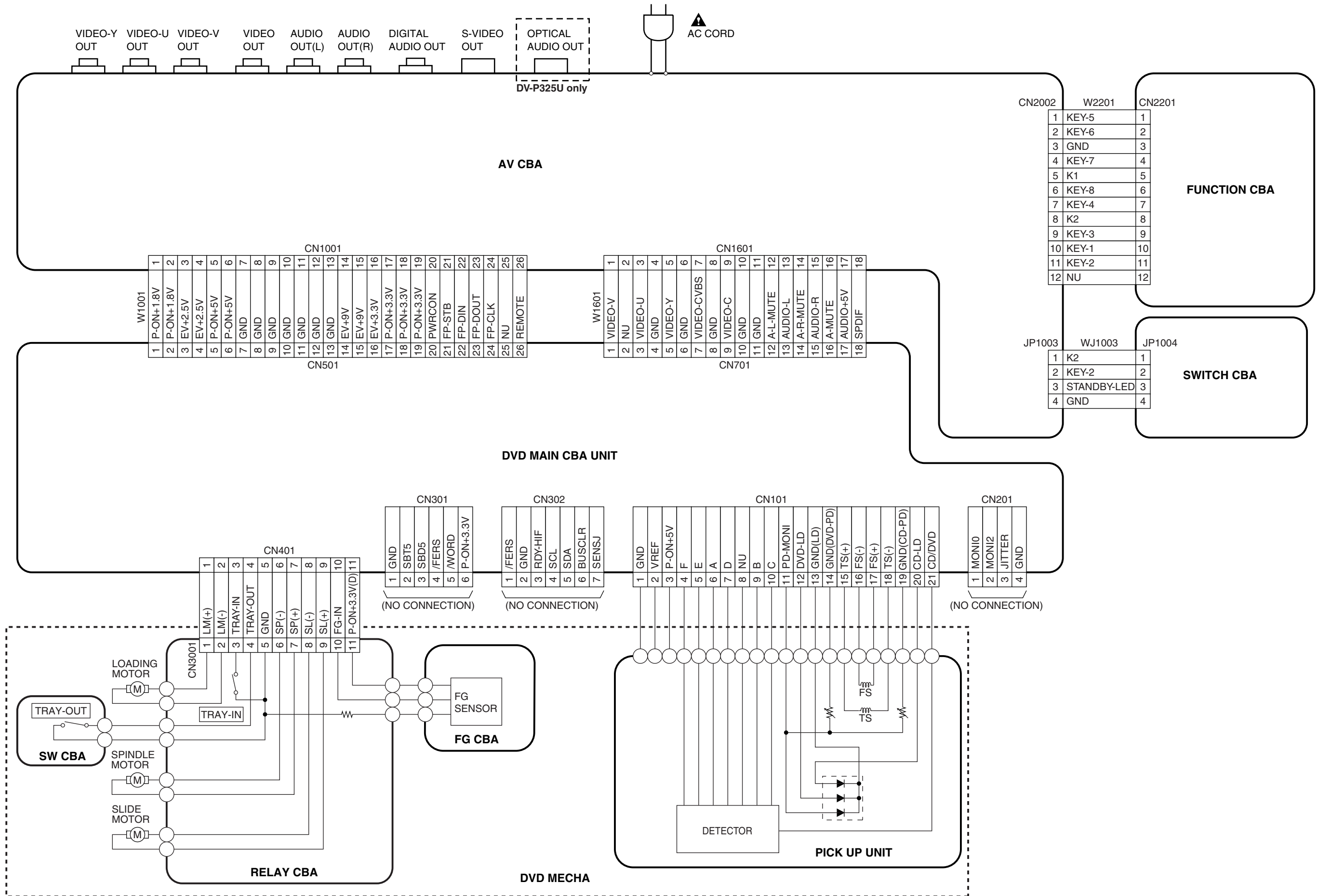

SYSTEM CONTROL TIMING CHARTS

Tray close ~ Play / Play ~ Tray open

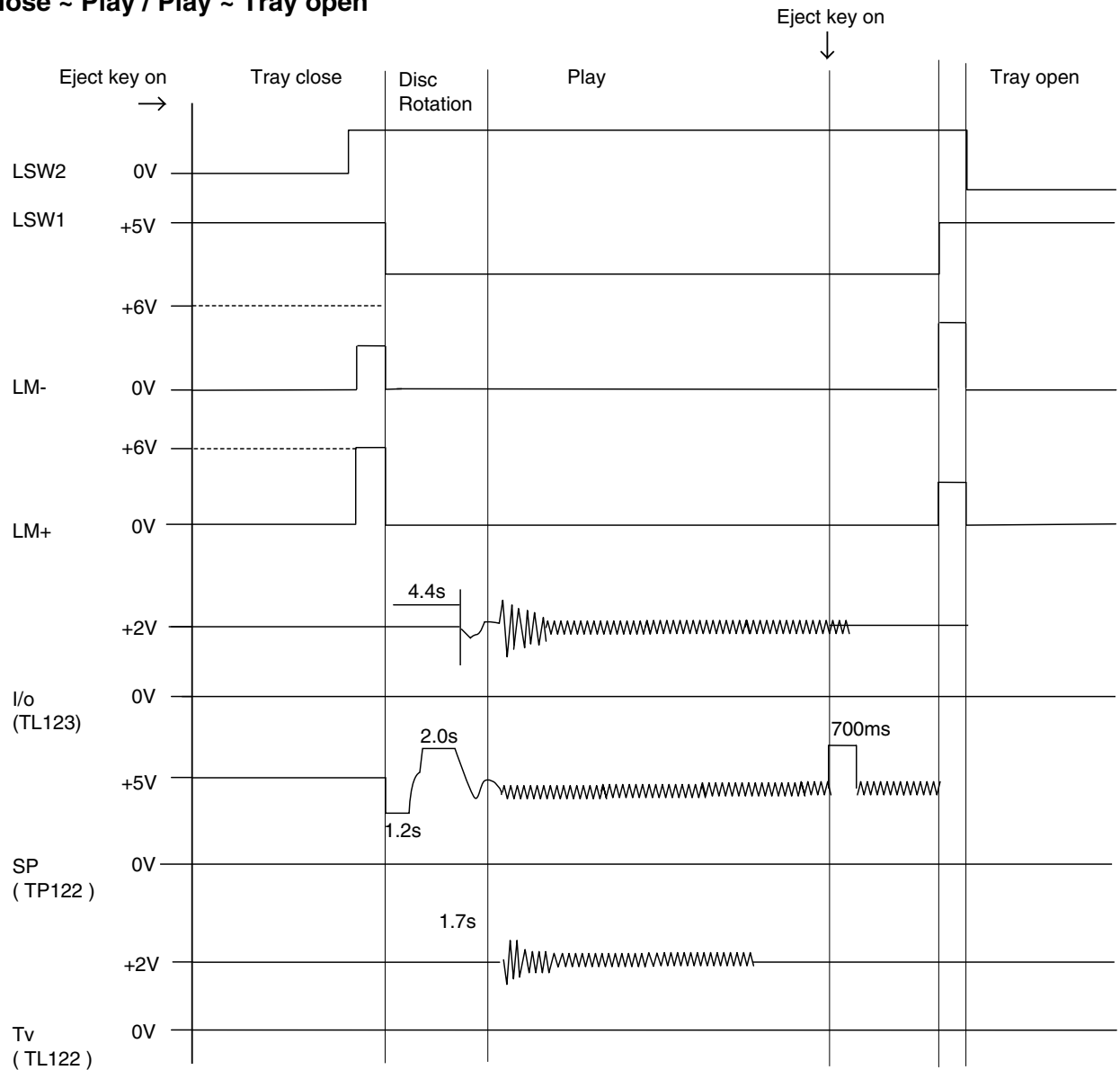

IC PIN FUNCTION DESCRIPTIONS

IC2001 [PT6315-S (-TP)]

Pin No.	In/Out	Signal Name	Name Function
1	In	CLK	Clock Input
2	In	STB	Serial Interface Strobe
3	In	K1	Key Data 1 Input
4	In	K2	Key Data 2 Input
5	-	VSS	GND
6	-	VDD	Power Supply
7	Out	a / Key-1	Segment Output / Key Souce-1
8	Out	b / Key-2	Segment Output / Key Souce-2
9	Out	c / Key-3	Segment Output / Key Souce-3
10	Out	d / Key-4	Segment Output/ Key Souce-4
11	Out	e / Key-5	Segment Output / Key Souce-5
12	Out	f / Key-6	Segment Output / Key Souce-6
13	Out	g / Key-7	Segment Output / Key Souce-7
14	Out	h / Key-8	Segment Output/ Key Souce-8
15	-	VEE	Pull Down Level
16	Out	i	Segment Output
17	Out	7G	Grid Output
18		6G	
19		5G	
20		4G	
21		3G	
22		2G	
23		1G	
24	-	VDD	Power Supply
25	-	VSS	GND
26	In	OSC	Oscillator Input
27	Out	DOUT	Serial Data Output
28	In	DIN	Serial Data Input

LEAD IDENTIFICATIONS

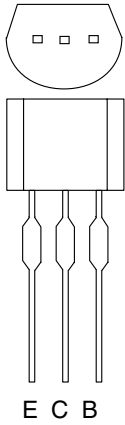

2SA1015-Y (TPE2)
KTA1266 (Y)
2SC1815-GR (TPE2)
2SA966 (Y)
2SC2236-Y-TPE6,C

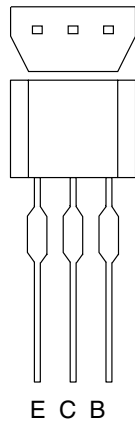

2SC2785 (H)
KTC3199 (GR)
KRA110M
KTA1273 (Y)
KRC110M-AT
BA1L3Z-T
BA1L3Z (P)
KTC3205 (Y)

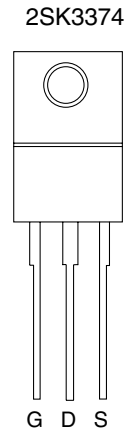

2SK3374

PQ018EF01SZ

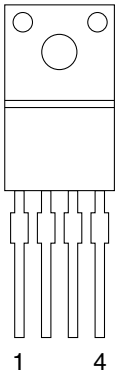

NJM4558D
KIA4558P

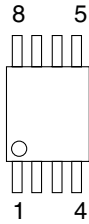

PT6315-S
PT6315-S(-TP)

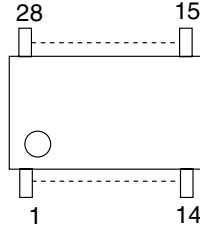

KIA431-AT
AN1431-(NSC)

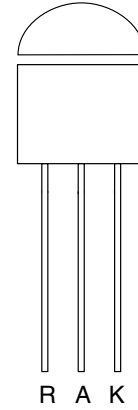

OC-0805T-002

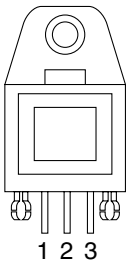

MM1567AJ

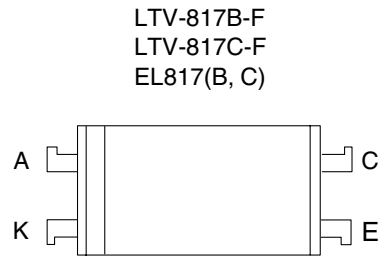
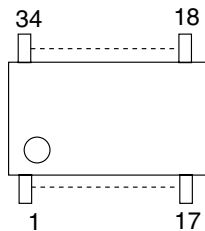

LTV-817B-F
LTV-817C-F
EL817(B, C)

Note:

- A: Anode
- K: Cathode
- E: Emitter
- C: Collector
- B: Base
- R: Reference
- 1 VCC
- 2 GND
- 3 OUT

EXPLODED VIEWS

Cabinet

(---) See Electrical Parts List for parts with this mark.

Some Ref. Numbers are not in sequence.

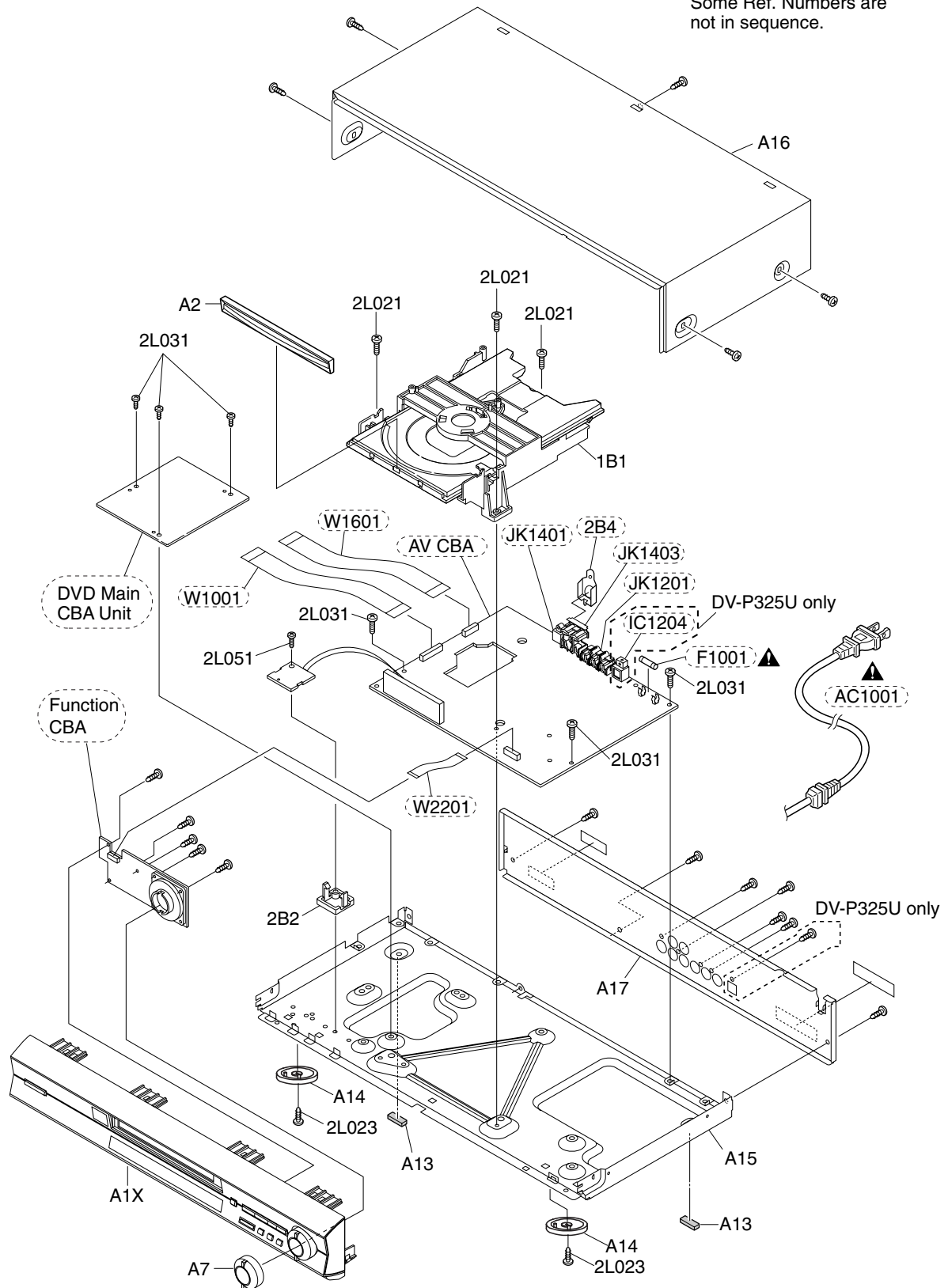

MECHANICAL PARTS LIST

SYMBOL-NO	P-NO	DESCRIPTION	SYMBOL-NO	P-NO	DESCRIPTION
MECHANISM SECTION					
A1X	TJ15672	FRONT ASSEMBLY [P325U]			
A1X	TJ15671	FRONT ASSEMBLY [P323U]			
A2	TJ15673	TRAY ASSEMBLY			
A7	TJ15674	JOG SHUTTLE KEY			
A13	TJ15675	FOOT			
A14	TS17051	FOOT ASSEMBLY			
A15	TJ15676	MAIN CHASSIS			
A16	TJ15677	TOP COVER SILVER			
A17	TJ15679	REAR PANEL [P325U]			
A17	TJ15678	REAR PANEL [P323U]			
△ AC1001	TE14761	AC CORD			
1B1	TS17001	DVD MECHA			
2B2	TJ15681	POWER PCB HOLDER			
2B4	TJ15651	EARTH PLATE			
2L021	TJ15682	SCREW (M3X10)			
2L023	TJ15683	SCREW (M3X6)			
2L031	TJ15683	SCREW (M3X6)			
2L051	TJ15682	SCREW (M3X10)			
ACCESSORIES					
X1	TJ16901	REMOTE CONTROL UNIT [P325U]			
X1	TJ16902	REMOTE CONTROL UNIT [P323U]			
X5	TE14751	AV CORD			

ELECTRICAL PARTS LIST

Note: Although some parts in the schematic diagrams have different names from those in the parts list, there is no problem in replacing parts.

SYMBOL-NO	P-NO	DESCRIPTION	SYMBOL-NO	P-NO	DESCRIPTION
SEMI-CONDUCTORS			Q1002	TC10778	TRANSISTOR KTC3199(GR)
D1001	TC10752	RECTIFIER DIODE 1N4005	Q1003	TC10778	TRANSISTOR KTC3199(GR)
D1002	TC10752	RECTIFIER DIODE 1N4005	Q1004	TC12301	TRANSISTOR KTC3205(Y)
D1003	TC10791	RECTIFIER DIODE BA157	Q1005	TC12311	TRANSISTOR KRC110M-AT
D1004	TC10752	RECTIFIER DIODE 1N4005	Q1006	TC12411	TRANSISTOR KRA110M
D1005	TC10752	RECTIFIER DIODE 1N4005	Q1007	TC12301	TRANSISTOR KTC3205(Y)
D1008	TC10877	SCHOTTKY BARRIER DIODE ERB81-004	Q1008	TC10778	TRANSISTOR KTC3199(GR)
D1009	TC10791	RECTIFIER DIODE BA157	Q1011	TC12321	TRANSISTOR KTA1273(Y)
D1011	TC10791	RECTIFIER DIODE BA157	Q1014	TC10778	TRANSISTOR KTC3199(GR)
D1012	TC10754	SWITCHING DIODE 1N4148M	Q1201	TC10778	TRANSISTOR KTC3199(GR)
D1013	TC10877	SCHOTTKY BARRIER DIODE SB140	Q1202	TC10778	TRANSISTOR KTC3199(GR)
D1015	TC12191	ZENER DIODE DZ-6.8BSBT265	Q1203	TC10784	TRANSISTOR KTA1266(Y)
D1016	TC10791	RECTIFIER DIODE BA157	Q1204	TC10784	TRANSISTOR KTA1266(Y)
D1017	TJ13897	ZENER DIODE MTZJT-7722B	Q1351	TC10778	TRANSISTOR KTC3199(GR)
D1018	TC10754	SWITCHING DIODE 1N4148M	Q2021	TC10784	TRANSISTOR KTA1266(Y)
D1022	TC10754	SWITCHING DIODE 1N4148M	TRANSFORMER		
D1024	TC10754	SWITCHING DIODE 1N4148M	△ T1001	TA14491	PULSE TRANS
D1025	TC10754	SWITCHING DIODE 1N4148M	COILS		
D1030	TJ15128	RECTIFIER DIODE FR202	△ L1001	TJ15243	LINE FILTER 20MH
D1036	TC12201	ZENER DIODE DZ-13BSBT265	L1007	TA14471	CHOKE COIL 22UH
D1045	TC10877	SCHOTTKY BARRIER DIODE SB140	L1009	TA14471	CHOKE COIL 22UH
D1046	TJ14689	ZENER DIODE MTZJT-775.6C	L1251	TA14481	INDUCTOR 0.47UH
D1047	TJ13895	ZENER DIODE MTZJT-775.6B	L1521	TA14471	CHOKE COIL 22UH
D1048	TC12211	ZENER DIODE DZ-12BSBT265	L2001	TA12561	INDUCTOR 100UH
D1049	TC10754	SWITCHING DIODE 1N4148M	MISCELLANEOUS		
D1050	TJ14752	ZENER DIODE MTZJT-776.2B	CN1001	TE14771	CONNECTOR
D2001	TC10754	SWITCHING DIODE 1N4148M	CN1601	TE14781	CONNECTOR
D2002	TC10754	SWITCHING DIODE 1N4148M	CN2002	TE14791	CONNECTOR
D2003	TC10754	SWITCHING DIODE 1N4148M	CN2201	TE14891	CONNECTOR
D2004	TC10754	SWITCHING DIODE 1N4148M	△ F1001	TE13223	FUSE 1A/250V
D2021	TJ14716	LED(RED) LT6311G-41	FC1001	TA14501	CLAMP FILTER
D2201	TC10754	SWITCHING DIODE 1N4148M	FH1001	TE11084	FUSE HOLDER
D2202	TC10754	SWITCHING DIODE 1N4148M	FH1002	TE11084	FUSE HOLDER
D2203	TC10754	SWITCHING DIODE 1N4148M	FL2001	TE14801	DISPLAY
D2204	TC10754	SWITCHING DIODE 1N4148M	JK1201	TE14811	JACK
△ IC1001	TE13224	PHOTOCOUPLER LTV-817B-F	JK1401	TE14821	JACK
IC1002	TC12231	IC PQ018EF01SZ	JK1403	TE14831	JACK
IC1003	TC12241	IC KIA431-AT	RM2001	TC12331	REMOTE RECEIVER
IC1006	TC12241	IC KIA431-AT	△ SA1001	TC10891	SURGE ABSORBER PVR-10D471KB
IC1201	TC12251	IC KIA4558P	SW2115	TE11957	TACT SWITCH
IC1204	TC12261	TRANS.MODULE 0C-0805T-002	SW2201	TE14901	JOG-SHUTTLE SWITCH
IC1402	TC12271	IC MM1567AJ			
IC2001	TC12281	IC PT6315-S			
Q1001	TC12291	TRANSISTOR 2SK3374			

SYMBOL-NO	P-NO	DESCRIPTION	SYMBOL-NO	P-NO	DESCRIPTION
SW2203	TE11957	TACT SWITCH			
SW2204	TE11957	TACT SWITCH			
SW2205	TE11957	TACT SWITCH			
SW2206	TE11957	TACT SWITCH			
SW2207	TE11957	TACT SWITCH			
SW2208	TE11957	TACT SWITCH			
SW2209	TE11957	TACT SWITCH			
SW2210	TE11957	TACT SWITCH			
SW2211	TE11957	TACT SWITCH			
W1001	TE14841	CABLE (26P)			
W1601	TE14851	CABLE (18P)			
W2201	TE14861	CABLE (12P)			
WJ1003	TE14871	WIRE			
WJ1004	TE14881	WIRE			

HITACHI