

HITACHI

SERVICE MANUAL

TK

NO. 9002E

DV-P505U
DV-P505E
DV-P505E(UK)
DV-P505U(PX)

ADVICE

Please carefully read this guide before using the device. The Hitachi DVD Player has been designed to prevent fire, electrical shock, injury, or harmful radiation. It has been legally fabricated in accordance with the Electrical Appliances Act. Therefore, when using the device, please follow advice in this service guide to keep it safe to use.

1. In brief

This is a device for DVD playback.

This device is to be used by connecting it to the video input terminal of a TV set.



2. Features

- Disc navigation system facilitates program search.
- Speedy operation by 2x speed drive.

SPECIFICATIONS AND PARTS ARE SUBJECT TO CHANGE FOR IMPROVEMENT.

DVD PLAYER



April 2000 Digital Media Products Division, Tokai

PRECAUTIONS FOR SAFETY (Please follow.)





Before undertaking repair work, please read through this [Precautions for safety].

The following points should be observed in order to prevent accidents from happening and to ensure the safety of the device.

- Degrees of danger or damage that can be caused by faulty operation are indicated by the following marks:

 <b style="font-size: 1.2em;">WARNING	Under this mark, there is "Possible death or serious injury".
 <b style="font-size: 1.2em;">CAUTION	Under this mark, there is "Possible injury or material damage".

- The following marks identify actions to be taken:

	This mark indicates items to which 'You should pay attention'.		This mark indicates items 'You have to accomplish'.
	This mark indicates: 'You should be cautious of electric shock'.		This mark indicates 'Forbidden items'.







 <h2 style="margin: 0;">WARNING</h2>	
<input type="checkbox"/> You should pay attention.  <p>Where a special attention is required, it is indicated by a label or stamp. For example, on the cabinet, chassis, or parts. Please respect the indicated items and the 'Precautions for use' of the manual.</p>	<input type="checkbox"/> The original part installation and wiring route shall be restored.  <p>For safety, some parts are insulated by a tube or a tape, or installed without contact with substrate. The internal wiring is kept a distance from hot or high voltage parts by clamps or routing. Please restore them as initially done to prevent electric shock or fire from happening.</p>
<input type="checkbox"/> You should be cautious against electric shock.  <p>Please be careful during operations because there are high voltage and recharging parts inside. An electric shock or death may happen by touching them. When disassembling, assembling, or replacing a part, the power plug has to be pulled off. Touching by error a powered part may cause an electric shock, death, or injury.</p>	<input type="checkbox"/> Please check safety after servicing.  <p>Please check if dismantled screws, parts, and wires are reinstalled as before and if the area surrounding the repair is damaged. Please also measure insulation resistance with a ohmmeter and to confirm that it is more than 20MΩ. There is risk of electric shock or fire if the insulation resistance is less than 20MΩ.</p>
<input type="checkbox"/> Please use designated parts.  <p>Parts are characterized by unflammability and voltage resistance. Therefore, parts having these same characteristics must be used in replacement. Especially for parts important in insuring safety, identified by  in the schematic or parts list, a part with the identical part number shall be used. If a part with a different part number is used, an electric shock or a fire may occur.</p>	

Table Of Contents

- Chapter 1 System Introduction 1**
 - System Specification1
 - Hitachi DV-P505U/U(PX)1
 - Hitachi DV-P505E/(UK)2
 - System Outlook3
 - Front Panel3
 - Display Window3
 - Rear Panel4
 - Description of adopted new technology5
 - Digital signal circuit5
 - Video circuit (DEC substrate)6
 - Video Output Circuit (VDO substrate)9
 - Audio Circuit11
 - FRONT (FSW) SUBSTRATE CIRCUIT12
 - POWER SUPPLY CIRCUIT12
 - CLOCK CIRCUITS13
 - Troubleshooting16
 - VIDEO CIRCUIT16
 - AUDIO CIRCUIT17
 - About System Reset Function20
 - System Utility20
- Chapter 2 Removal and Replacement 21**
 - General Information22
 - Before You Begin22
 - Disassembly Procedure Flowchart23
 - Disassembly Procedure24
 - Removing the Top Cover24
 - Removing the Foot Stand24
 - Removing the Front Panel25
 - Removing the MPEG Control Board26
 - Removing the Power Supply Board27
 - Removing the DVD-ROM Drive27
 - Removing the Outlet Board28
 - Removing the Front Panel Control Boards29
 - Connector Location30
- Appendix A Schematics 33**

System Introduction

System Specification

Hitachi DV-P505U/U(PX)

Specification	
General	Model DV-P505U/U(PX) Operating laser Semi-conductor laser : Wave length 650nm(DVD) / 780nm(CD,VCD) Power supply DV-P505U : AC120V, 60Hz DV-P505U (PX) : AC110-240V, 50/60 Hz Power consumption24W Weight 3.7 kg Overall size434 (W) x 284 (D) x 91 (H) mm Allowable operating temperature +5°C~+35°C Allowable operating humidity 15~75% (no condensation)
Component output terminal	Y output level 1 Vp-p (75Ω) P _B output level NTSC : 0.7 Vp-p (75Ω) PAL : 0.698 Vp-p (75Ω) P _R output level NTSC : 0.7 Vp-p (75Ω) PAL : 0.698 Vp-p (75Ω) Output terminal pin jack
S Video output terminal	Y output level 1Vp-p (75Ω) C output level NTSC : 0.286Vp-p (75Ω) PAL : 0.3Vp-p (75Ω) Output terminal S terminal
Video output	Output level 1 Vp-p (synchronous when loaded at 75Ω) output terminal pin jack
Audio output	Output level200mVrms (1kHz, -20dB) Mixed 2ch output 1 system (pin jack x 2) 5.1ch output 1 system (pin jack x 6) Sound characteristics : Frequency characteristics CD : 4Hz~20kHz (EIAJ) DVD : 4Hz~22kHz (48k sampling) 4Hz~44kHz (96k sampling) SN ratio 110 dB Dynamic range90dB Total harmonic distortion rate0.005% Wow/flutter Measurement limit less than (±0.001% W.PEAK)(EIAJ)
Other terminals	Digital audio output optical/coaxial Coaxial terminal : 1 (DTS/AC-3/MPEG2, LPCM, OFF commutable) Optical connector : 1
Accessories	Remote control unit 1 Single 'AAA' battery 2 AV cord 1 Power cord 1 AC socket (DV-P505U(PX) only) 1

Hitachi DV-P505E/E(UK)

Specification	
General	Model DV-P505E/E(UK) Operating laser Semi-conductor laser : Wave length 650nm(DVD) / 780nm(CD,VCD) Power supply DV-P505E : AC230V, 50Hz Power consumption 24W Weight 3.7 Kg Overall size 434 (W) x 284 (D) x 91 (H) mm Allowable operating temperature +5°C~+35°C Allowable operating humidity 15~75% (no condensation)
AV connector output terminal	AV connector output 21-pin connector This connector provides the video and signals for connection to a color video TV monitor (or TV set) which has an 'AV CONNECTOR' terminal.
S Video output terminal	Y output level 1Vp-p (75Ω) C output level NTSC : 0.286Vp-p (75Ω) PAL : 0.3Vp-p (75Ω) Output terminal S terminal
Video output	Output level 1 Vp-p (synchronous when loaded at 75Ω) Output terminal pin jack
Audio output	Output level 200mVrms (1kHz, -20dB) Mixed 2ch output 1 system (pin jack x 2) 5.1ch output 1 system (pin jack x 6) Sound characteristics : Frequency characteristics CD : 4Hz~20kHz (EIAJ) DVD : 4Hz~22kHz (48k sampling) 4Hz~44kHz (96k sampling) SN ratio 110 dB Dynamic range 90dB Total harmonic distortion rate 0.005% Wow fluttertics Measurement limit less than (±0.001% W.PEAK)(EIAJ)
Other terminals	Digital audio output optical/coaxial Coaxial terminal : 1 (DTS/AC-3/MPEG2, AC3, LPCM, OFF commutable) Optical connector : 1
Accessories	Remote control unit 1 Single 'AAA' battery 2 AV cord 1 Power cord 1

System Outlook

FRONT

<Display>

Lights if the stop position is in memory.

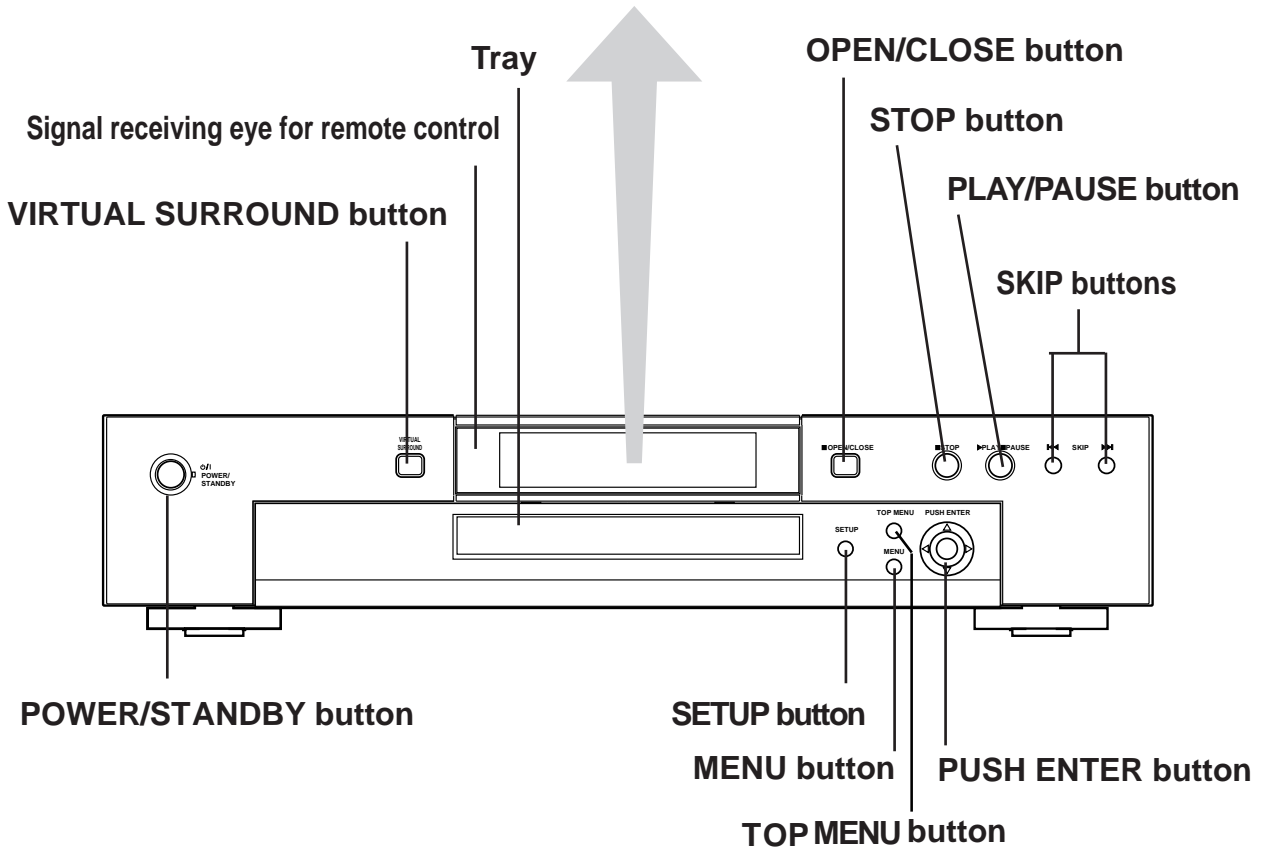
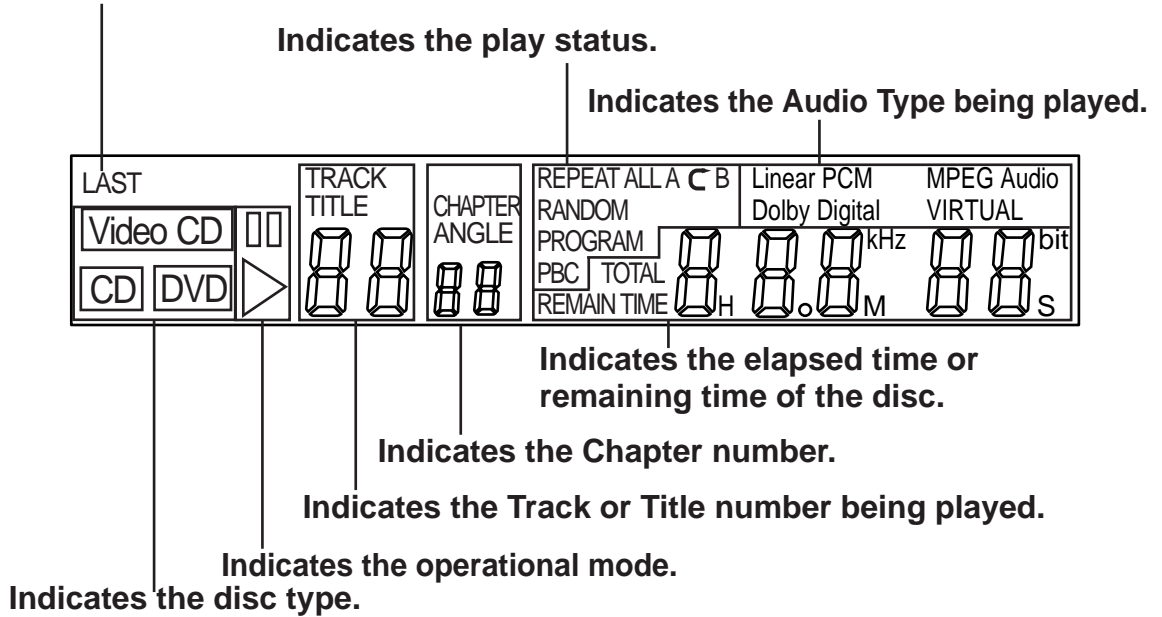

Rear Panel

DV-P505E / E(UK)

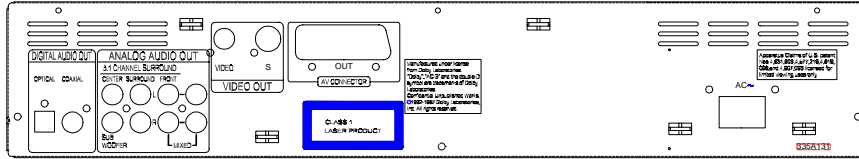

DV-P505U / U(PX)

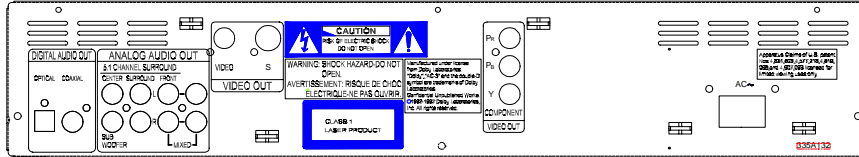

Description of adopted new technology

Digital signal circuit

Data Flow

The following figure shows the block diagram of digital signal circuit.

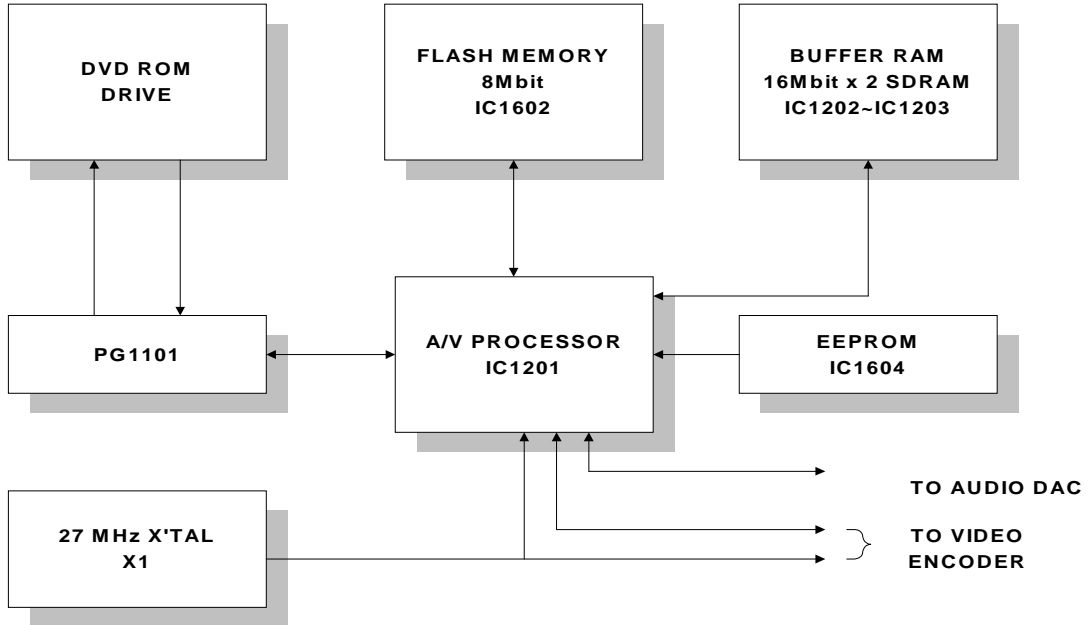

The disc data read by DVD ROM Drive will be passed to A/V processor (IC1201) through 16 bits parallel interface. A/V processor (IC1201) parses the system layer and demultiplexes the audio and video streams. Audio is decoded and passed through the audio interface to external audio DACs (IC 1501~1503) and then to the speakers. Video is decoded and output as $YCbCr$ pixels to video encoder (IC2201).

Reference Clock of each IC

IC	Reference Clock
IC1201 A/V PROCESSOR	System clock and video interface clock are input from X1201 27MHz X'TAL. Audio interface clock is output at 39 pin named DA-XCK to Audio DAC.
IC1601 FLASH MEMORY	Nil (Control signal is generated by IC1201)
IC1202-IC1203 BUFFER RAM	Nil (Control signal is generated by IC1201)
IC1604 EEPROM	Nil (Control signal is generated by IC1201)

Functions of each IC

No.	IC	Functions	Operating Voltage
1	IC1201 A/V PROCESSOR	Execute data transfer, presetting and control of each IC. Execute decompression (decoding) of data compressed by MPEG, AC3, DTS.	3.6V
2	IC1601 FLASH MEMORY	Store memory for A/V processor's RISC software	5V
3	IC1202~IC1203	Memory used for decompression (decoding) of data compressed by MPEG and control by A/V processor.	3.3V
4	IC1604 EEPROM	Store program code of system	5V

The following is the description of the functions of each IC:

- 1. A/V PROCESSOR (IC1201)**
It is a single-chip A/V processor that integrates several modules functioning MPEG video decoding, DVD system navigation, Content Scrambling System(CSS), DolbyTM Digital (AC-3), DTS and MPEG audio decoding respectively.
Data input is separated into video data and audio data. Then the two data is decoded and output as digital video and digital audio respectively. A build-in RISC transfers data and executes presetting and control of each modeule.
System clock, clock of video interface signals operate by inputting 27MHz respectively.
- 2. Flash Memory (IC1601)**
A 4Mbits flash memory is used. It stores program of the preceding build-in RISC and its access is controlled by said RISC.
- 3. BUFFER SDRAM (IC1202~1203)**
Two 16Mbits SDRAM are used. A/V processor controls it and it is used to decompress audio and video compressed by MPEG.
- 4. EEPROM (IC1604)**

Video circuit (DEC substrate)

8bit $Y C_R C_B$ digital video stream (Parallel) output from A/V processor are input to video encoder ADV7170(IC2201). Video encoder is preset in master mode that generates reference signals and receives 27MHz from system clock X1 and outputs Horizontal, Vertical synchronous signals to A/V processor.

By presetting of internal register, video encoder generates:

- 1. NTSC** (North America, Japan, Taiwan)
- 2. PAL** (Europe, Asia)

standard analog video signals.

Filter circuit eliminates high frequency components of analog video signals output from video encoder. Afterwards in S2 processor circuit DC voltage is superposed on C signals then output 3 types of video signals: composite video signals, Y/C(S2) video signals and YP_BP_R/RGB to RJK substrate via 17P connector (PG2201).

The following is a description of video circuit along signal flow:

Block Diagram of VIDEO ENCODER ADV7170 (IC2201) interior

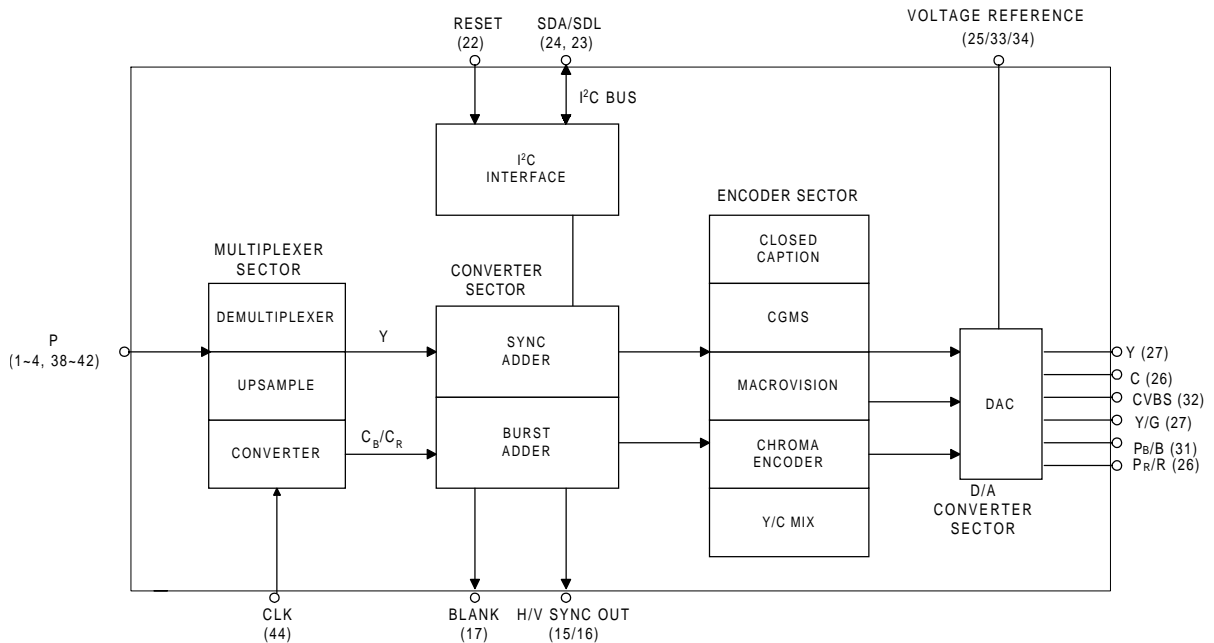

VIDEO ENCODER ADV7170 (IC2202)

1. MULTIPLEXER SECTOR

It transforms input digital video stream (Input at 1~4, 38~42 pins) in 8bit parallel data then separates them in Y data and C_B/C_R data and changes simultaneously the rate (6.75MB/S->13.5MB/S).

2. CONVERTER SECTOR

It generates various internal timing signals with the synchronous signal as standard by adding synchronous signals generated in IC to Y data, according to the conditions set in the internal register or by adding BURST signals to C_B/C_R data. At the same time it outputs these synchronous signals to A/V processor (Output at 15,16 pins). In addition, when power is turned ON, RESET signal (Input of L level at 22 pin) is input to reset the register in IC.

Moreover, writing in the internal register (presetting) is done via I2C BUS (23,24 pins).

3. ENCODER SECTOR

The following a~c data are inserted in VIDEO DATA according to preset conditions in the internal register:

- a. Closed caption
NTSC Mode: 21 lines and 284 lines/ PAL Mode: 22 lines and 335 ines.
- b. CGMS (Copy Guard Management System)
20 lines and 283 lines of NTSC.
- c. Macrovision Copy Prevention System (Anti Taping)
Finally it generates Analog Colorstripe, AGC Pulses, Pseudo-sync, EOF Back Porch Pulses.
- d. D/A CONVERTER (DAC)SECTOR
Constituted of 10bit DAC, it transforms DIGITAL VIDEO DATA to ANALOG VIDEO DATA for output.

Under control of output voltage by DAC pins (25, 33, 34 pins), it output 3 kinds of ANALOG VIDEO SIGNALS:

1. ANALOG COMPOSITE VIDEO SIGNALS (CVBS/32 pin), output voltage 1.0Vpp.
2. ANALOG S VIDEO by ANALOG LUMINANCE SINGLES (Y/27 pin), output voltage 1.0Vpp and ANALOG CHROMA SIGNALS (C/26 pin), BURST part output voltage 286mVpp.
3. ANALOG COMPONENT YP_BP_R/RGB.

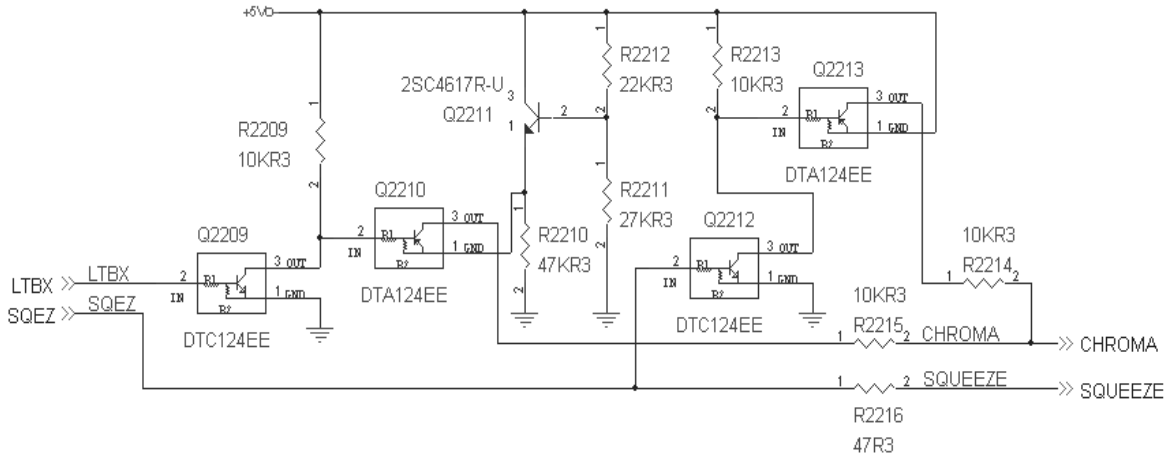

S2 Processing Circuit (only for Japan)

S2 is a standard used in wide television sets possessing screen size switching function in NTSC mode. By inputting VIDEO signals formed by superposing DC voltage on C signal at S input terminal, it switches automatically to TV display size. The DC voltage superposed on C signal varies according to the ASPECT RATIO of VIDEO SIGNALS.

1. Case of SQUEEZE SIGNAL (*1)
H-level voltage is input in SQUEEZE INPUT; Q2212 and Q2213 are powered and +4V DC voltage is superposed on C signal output line.
 2. Case of LETTER BOX SIGNAL (*2)
H-level voltage is input in LETTER INPUT; Q2209, Q2210, and Q2211 are powered and +1.8V DC voltage is superposed on C signal output line.
1. *1: It is a laterally shrunk image information with 525 lines and an aspect ratio of 16:9 carried by the standard TV signal format of 525 lines and an aspect ratio of 4:3. When viewing on a 4:3 TV set, the image appears vertically oblong.
 2. *2: It is a wide screen signal in the standard TV signal format of 525 lines and an aspect ratio of 4:3 with coexistence of upper and lower blank areas of 525 lines and an aspect ratio of 4:3 screen and the principal image area of 4:3 aspect ratio (line 53~232/316~495). When viewing on a 4:3 TV set, one sees black areas at the top and bottom of the screen.

Video Output Circuit (VDO substrate)

Analog composite video signals (CVBS), analog luminance signals (Y), analog chroma signals (C) and analog component signals ($Y_P B_P R_{/RGB}$) are sent from DEC substrate to VDO substrate by passing through 17P connector (PG2201~PG1302). From VDO substrate, CVBS signals are output from output terminal J1307 and Y/C signals are output from output terminal J1302. Component signals are output from output terminal J1306 ($Y_P B_P R$) or J1361 (RGB).

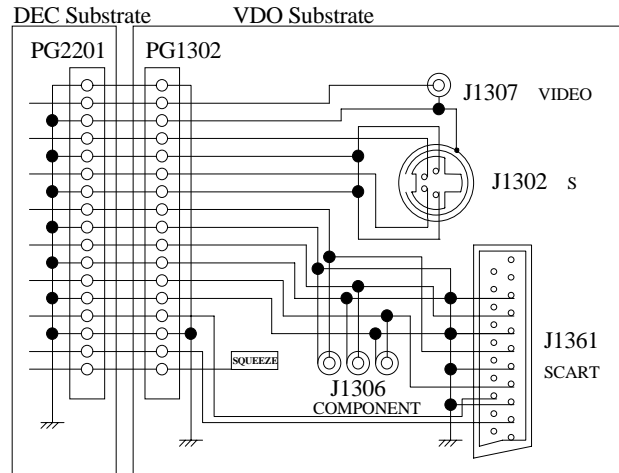

Audio Circuit

Audio circuit is shown in page 11.

Audio circuit is composed of D/A converter sector (DEC substrate) that transforms digital audio signals output from A/V processor (IC1201), analog processing sector (RJK substrate) that consists of an operational amplifier, and mute circuit (DEC substrate, RJK substrate) for stopping audio output when required.

1. D/A CONVERTER SECTOR (DEC substrate)

D/A converter sector is composed of IC1503 that receives and transforms digital audio signals from A/V processor in analog signals.

IC1503 is a converter corresponding to FL and FR signals of sampling frequencies 44.1/48/96KHz and data lengths 16/20/24bit, and digital audio signals from A/V processor is input at pin 2.

To these digital audio signals are inserted FL and FR signals in time sharing mode. When they are input in pin 1, they are separated in FL and FR signals by R clock and after transformation analog FL signals are output at pin 16 and FR signals at pin 13. Moreover, when there are no input signals at pin 2, a signal called ZERO MUTE is output to pin 21 to mute useless noises (See paragraph on MUTE CIRCUIT.)

Every functions of IC1503 is preset by IC 1201 and controlling signals from IC1201 are input at pins 26, 27, and 28. As for presetting items, there are data length, sampling frequency, signal polarity, and de-emphasis.

2. ANALOG PROCESSING SECTOR (RJK substrate)

Analog processing sector is composed of operational amplifier IC1508 that is a filter and operational amplifier IC1510 that amplifies audio signals.

Filter portion is composed of RC low pass filter and IC1508 formed active low pass filter and there are 3 sections. The diagram below shows its filter portion circuit (for FL signals only).

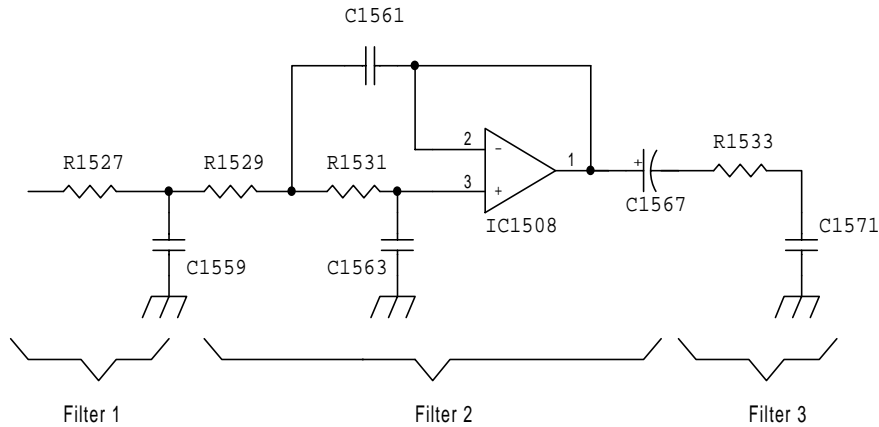

This 3-section filter constitutes a low pass filter of overall cutoff frequency of 44kHz. Audio signals after low pass filter is amplified by IC1510 by about 6dB and output to audio out1 and audio out2. Here, among audio signals, FL signals are input at pin 3 of IC1508 and output from pin 1, then input to pin 2 of IC1510 then output from pin 1. FR signals are input at pin 5 of IC1508 and output from pin 7, then input to pin 6 of IC1510 then output from pin 7.

3. MUTE CIRCUIT (DEC substrate, RJK substrate)
 The principal role of mute circuit is the erasing of useless noises occurring when power is turned on. Mute signal for noise erasing is generated by IC1201, reverse-amplified by Q2501 and Q2502. Then by putting Q1310 and Q1311 'ON', it mutes audio signals. In addition, if IC1501 detects no-signal, it generate a mute signal called ZERO MUTE. This latter is reverse-amplified by Q1501 and mutes useless audio signals by putting Q1310 and Q1311 'ON'.
4. 5.1CH Difference List

Output	D/A Converter	Operational amplifier
Front L/R	IC 1503	IC 1508, IC 1510, IC 1517
Surround L	IC 1502	IC 1511, IC 1512
Surround R	IC 1501	IC 1511, IC 1512
Center	IC 1501	IC 1513, IC 1514
SUBW	IC 1502	IC 1513, IC 1514, IC 15188

AUDIO CIRCUIT

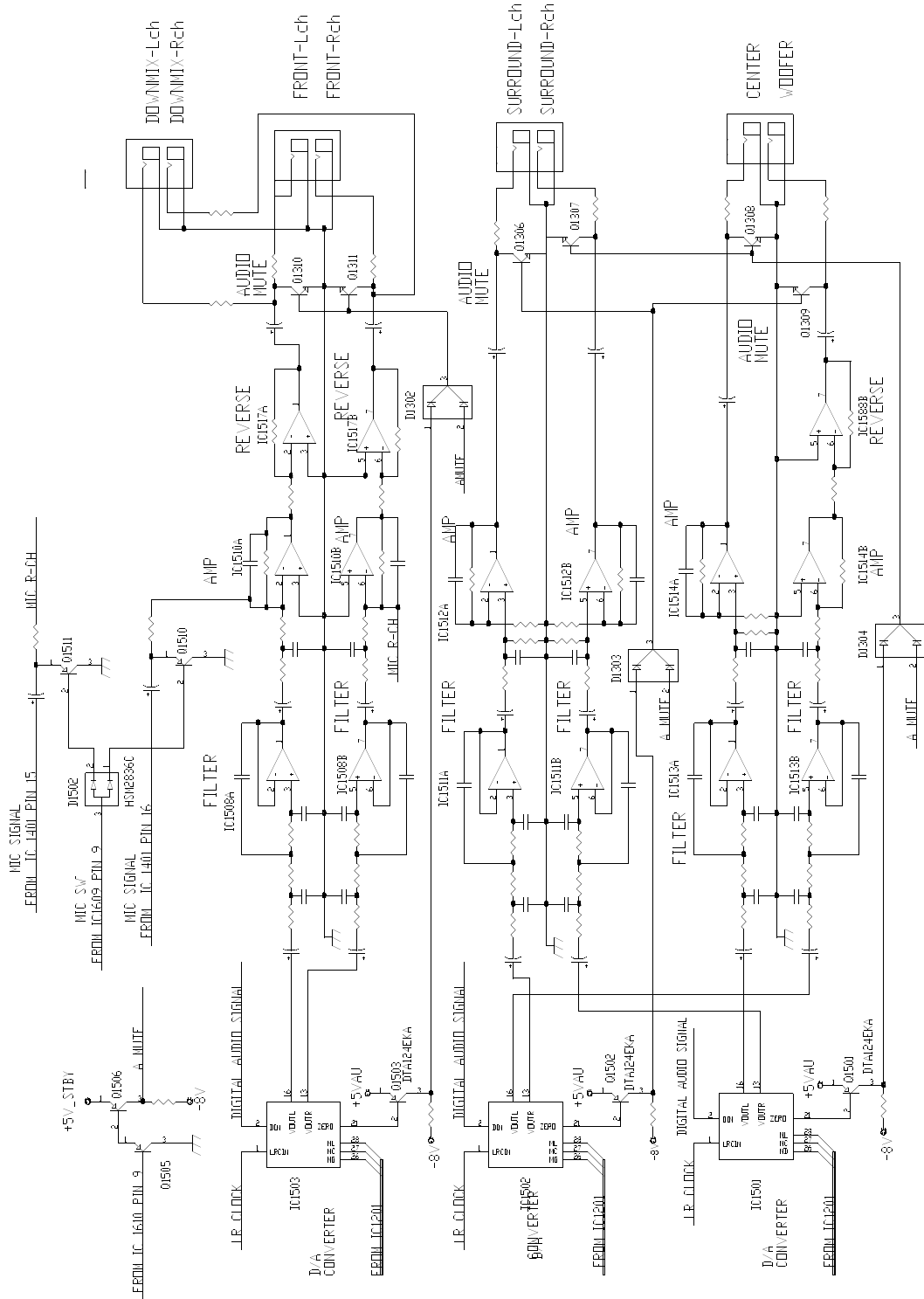

FRONT (FSW) SUBSTRATE CIRCUIT

1. FL MICOM (IC1701)
It performs communications with IC 1201 (pins 5, 6, 8, 9), including the main frame key, FL tube (IC1702) drive. In addition, it works also in standby mode.
2. INCLUSION OF MAIN FRAME KEY
Input is done to FL MICOM at pins 10~13 for operation of S1701 ~ S1709 of mainframe key. Remote control signal is received by ultra-red receiver element (IC1703), output at pin 1 and input to IC 1201 at pin 166.
3. FL TUBE DRIVE
Grid voltage of FL TUBE at pins 33~38 is controlled from FL MICOM at pins 39~44; anode voltage of FL TUBE at pins 5~23 from FL MICOM pins 15~32, 35.
Filament voltage (AC 3.5V) is supplied from power source to FL TUBE at pins 1, 2, 41, and 42.
4. POWER INDICATOR
Control signals are output from A/V processor pins 17 and 18 to lights 2-color LED (LED1761) green or red. When power button is pushed 'ON', P. ON/OFF signal is output from A/V processor pin 17 and it switches ON all system powers and red LED is lighten by a 5V; When standby, only STABLE signal is output to light green LED.

POWER SUPPLY CIRCUIT

1. ESSENTIAL OF POWER SUPPLY CIRCUIT OPERATION
Power supply is RCC switching type. Energy is stored in transformer T1, when FETQ1 is 'ON', by AC110~240V impressed at AC inlet. After that, when FETQ1 turns 'OFF', the energy is released to the secondary side power supply. Two diverse circuits from secondary side includes SW (S5V, S 8V, S-8V, S12V) that are put 'ON' by A/V processor control. Signal (P. ON / OFF) of PG1201 pin 1 and permanently 'ON' supplies (A5V, A4.5V, AC3.5V, A-24V).
Detection of secondary side voltage is by A5V. D15, and C18 compose its secondary side commutating circuit. It is fed back by photo-coupler PHC1 to primary side and maintains stable output voltage and is supplied to FL MICOM and ultra-red reception element.
S5V output is from A5V output and by intermediary of output control circuit Q7.
S4.5V is output from S5V diode D12.
D13 and C16 compose secondary commutating circuit of S12 that is for DVD-ROM drive use.
D13 and C16 compose secondary commutating circuits of S8V that is output by 3-terminal regulator IC2.
For audio circuit proper +5V power supply, AUD S5V is produced from S8V in 5V regulator IC1504 (in DEC substrate).
D19 and C27 compose secondary commutating circuit of S-8V.
A-20V is negative power supply to FL tube. D16 and C23 compose its secondary commutating circuit.
AC3.5V is for FL tube heater. To prevent fluctuation of output voltage due to that of power source, a self-exciting push-pull circuit is used. It is input from A5V, passes DC/AC inverter composed of transistors Q5, Q6 and transformer T2 and output. It supplies stable voltage without being disturbed by power source fluctuations. It plays an important role in FL tube life maintenance and against brightness decrease.
2. OPERATION OF PROTECTION CIRCUIT
Protection circuits are different according to different power supplies.
For A5V and S5V, when load current increases and exceeds the control limit of the primary side of the regulator, the over current protection circuit of the primary side operates and regulator output will decrease suddenly. At the same time other outputs stop.
For S12V and S8V, when load current increases and exceeds the control limit of 3-terminal regulator, the internal over current protection circuit operates and output will suddenly decrease.
By pulling off plug from wall socket, eliminating short circuit, replace destroyed parts, and plug in again, the normal state will be restored in its secondary commutate.

CLOCK CIRCUITS

27MHz X'TAL (X1201)

Block diagram for 27 MHz clock circuit is shown in Fig. 5-8-1.

When power is supplied to 27 MHz X'TAL, it generates 27MHz clock and input it to A/V processor (IC1201), video encoder (IC2201).

1. A/V PROCESSOR
The A/V processor uses it as CLOCK PCLK2X (input at pins 117) of video interface signal and output digital video stream synchronized to PCLK2X from 8bit video data bus VDATA[7:0] (output at pins 106, 107, 108, 109, 110, 113, 114, 115)
2. VIDEO ENCODER
At video encoder it is used as system clock CLK (input at pin 44) and output horizontal synchronous HSYNC (output at pin 15) and vertical synchronous VSYNC (output at pin 16) to A/V processor.
3. Audio DA Converter
The audio external frequency clock signal DA-XCK is used as system clock. DA-XCK is supplied from A/V processor (output at pin 39) to Audio DAC (input at IC1501~IC1503 pin 5).
IC1201: The DA-XCK is used to generates Audio bit clock TBCK (output at pin 40) and LR clock TWS (output at pin 32).

DA-XCK	Is interior clock used for generating TBCK and TWS, DA-XCK takes frequency 384 times the sampling frequency.
TBCK	Is Audio bit clock obtained by dividing DA-XCK in 8 equal parts. It takes frequency 48 times that of sampling.
TWS	Is clock that identifies channel (Lch or Rch) against all Audio sampling.

* The Audio Interface Unit inside A/V processor corresponds to sampling frequencies (fs) 44.1kHz (CD-DA, Video-CD), 48kHz, 96kHz (DVD).

The frequency of TBCK is defined by Formula 1:

$$f \text{ TBCK} = \text{Audio data bit length} * 2 * fs \dots\dots\dots 1$$

At A/V decoder, interior DA-XCK is divided into 8 equal parts and output as TBCK (Formula 2)

$$f \text{ TBCK} = f \text{ DA-XCK} / 8 \dots\dots\dots 2$$

Therefore, DA-XCX frequency takes the value 384fs according to formulas 1 and 2. Audio data bit length is fixed 24bit. (Formula 3)

$$f \text{ DA-XCX} = \text{Audio data bit length} * 2 * fs * 8 = 24 * 2 * fs * 8 = 384 fs \dots\dots\dots 3$$

According to Formulas 2 and 3, A/V decoder drives TBCK with frequency 48 times of sampling frequency. (Formula 4)

$$f \text{ TBCK} = 384fs / 8 = 48fs \dots\dots\dots 4$$

The relationships between Audio interface signals (DA-XCK, TWS, TBCK) and each sampling frequency are as follows:

- ❑ Sampling frequency: 44.1 kHz (For CD-DA and Video-CD)
 - DA-XCK 384*fs=16.934MHz
 - TBCK DA-XCK/8=2.1168MHz
 - TWS TBCK/48=44.1kHz=fs
- ❑ Sampling frequency: 48kHz (for DVD)
 - DA-XCK 384*fs=18.432MHz
 - TBCK DA-XCK/8=2.304MHz
 - TWS TBCK/48=48kHz=fs

-
- Sampling frequency: 96kHz (for DVD)
 - DA-XCK $384 \cdot f_s = 36.864 \text{MHz}$
 - TBCK $\text{DA-XCK}/8 = 4.608 \text{MHz}$
 - TWS $\text{TBCK}/48 = 96 \text{kHz} = f_s$

BLOCK DIAGRAM OF 27MHz CLOCK CIRCUITS

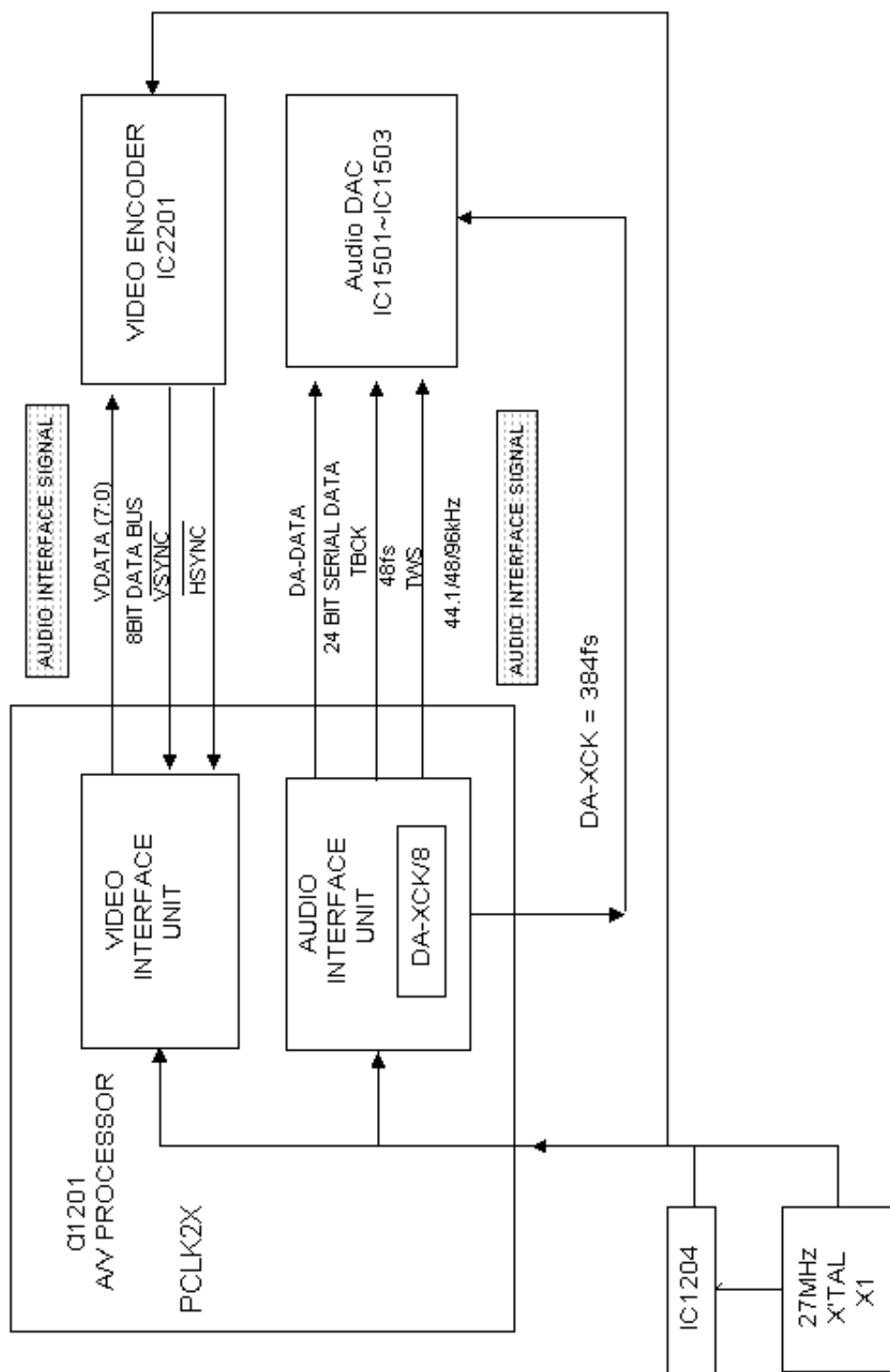

Troubleshooting

VIDEO CIRCUIT

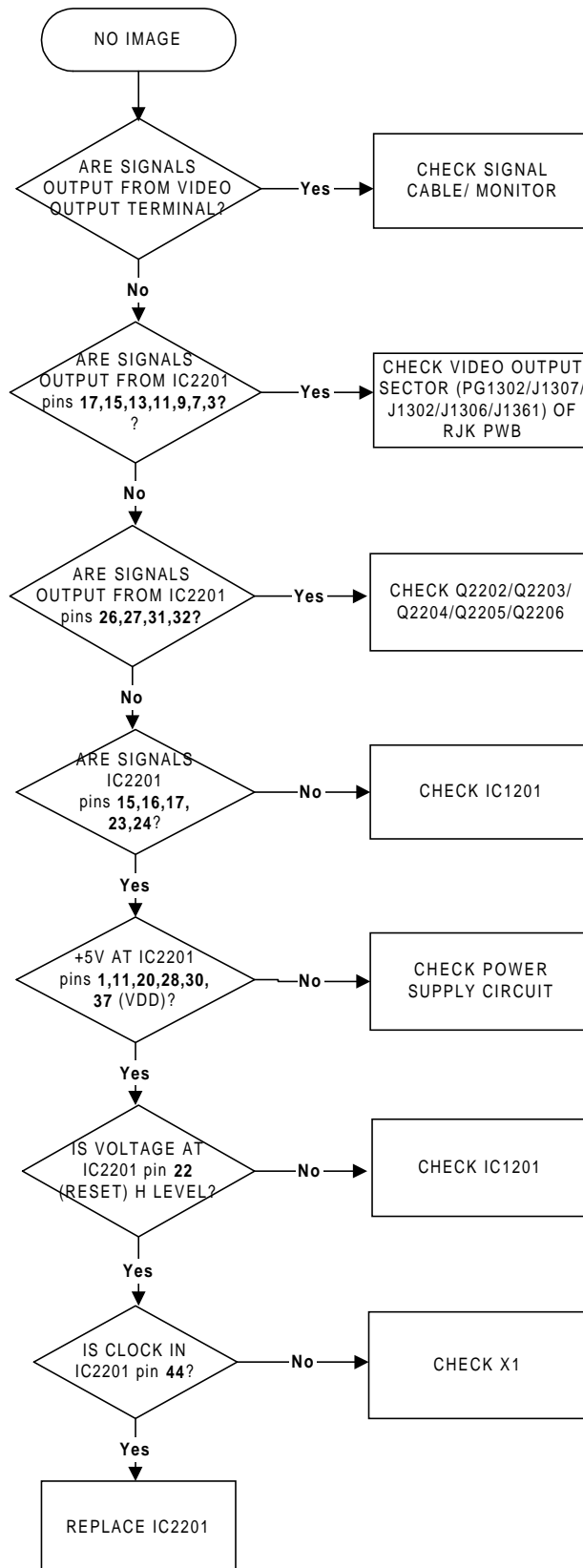

AUDIO CIRCUIT

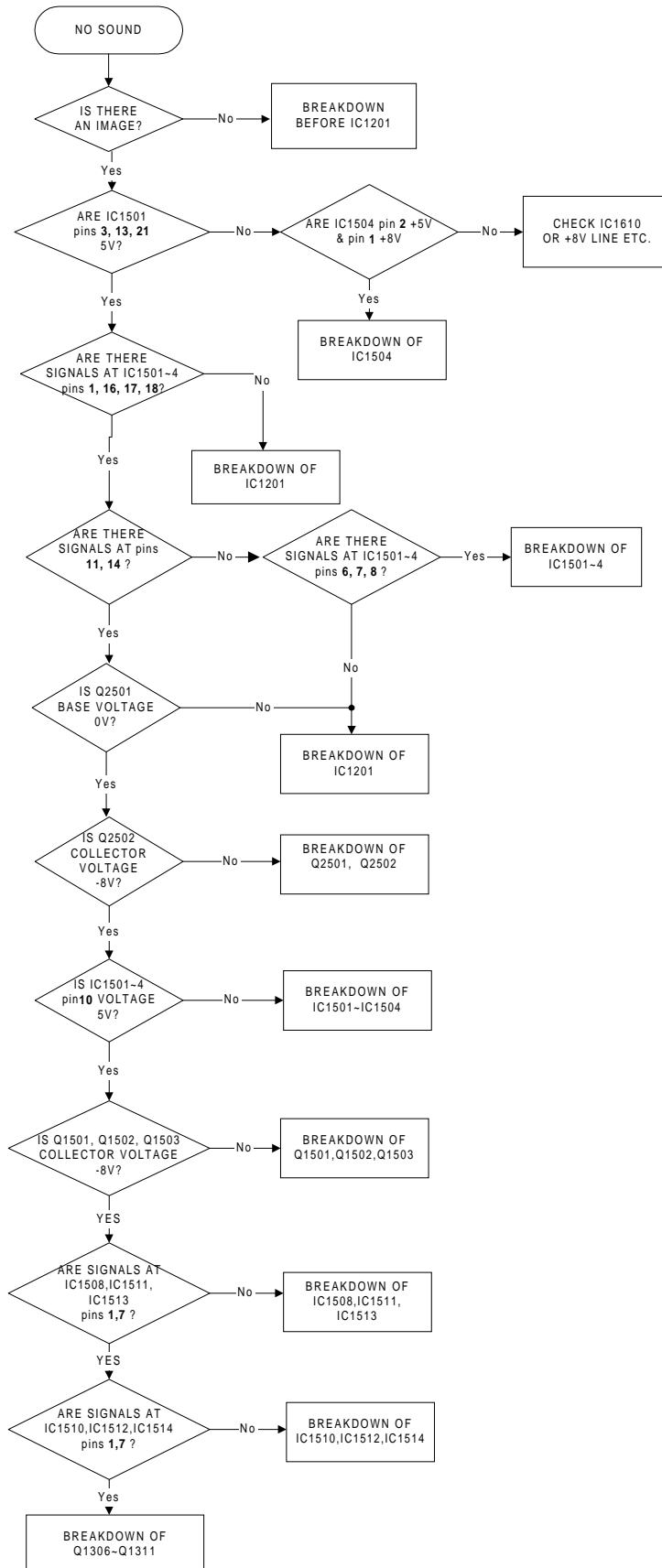

DV-P505 SERVICE PARTS LIST		
SYMBOL NO	P-NO	DESCRIPTION
MECHANISM SECTION		
△ 101	TS15611	POWER UNIT
102	TE13411	CONNECTOR
103	TE13421	CONNECTOR [U]
103	TE13501	CONNECTOR [E,UK]
104	TE13431	CONNECTOR
105	TE13441	CONNECTOR
106	TE13451	CONNECTOR [U]
106	TE13561	CONNECTOR [E,UK]
△ 107	TE13461	FUSE
108	UQ22621	MECHA ASSY(DVD)
109	TA14171	RESISTOR FUSIBLE (R34)
△ 110	TE13531	CORD,POWER [U]
△ 110	TE13541	CORD,POWER [E]
△ 110	TE13551	CORD,POWER [UK]
111	TJ14111	PANEL,FRONT [U]
111	TJ14112	PANEL,FRONT [E,UK]
112	TJ14131	COVER, TOP [U]
112	TJ14132	COVER, TOP [E,UK]
113	TJ14151	PANEL, TRAY [U]
113	TJ14152	PANEL, TRAY [E,UK]
114	TJ14261	PANEL, REAR [U]
114	TJ14262	PANEL, REAR [E,UK]
115	TJ14271	BUTTON [U]
115	TJ14272	BUTTON [E,UK]
116	KK10323	BELT
ACCESSORIES		
802	TE15679	REMOTE HAND SET
803	TE13081	CORD,AV

Exploded Diagram

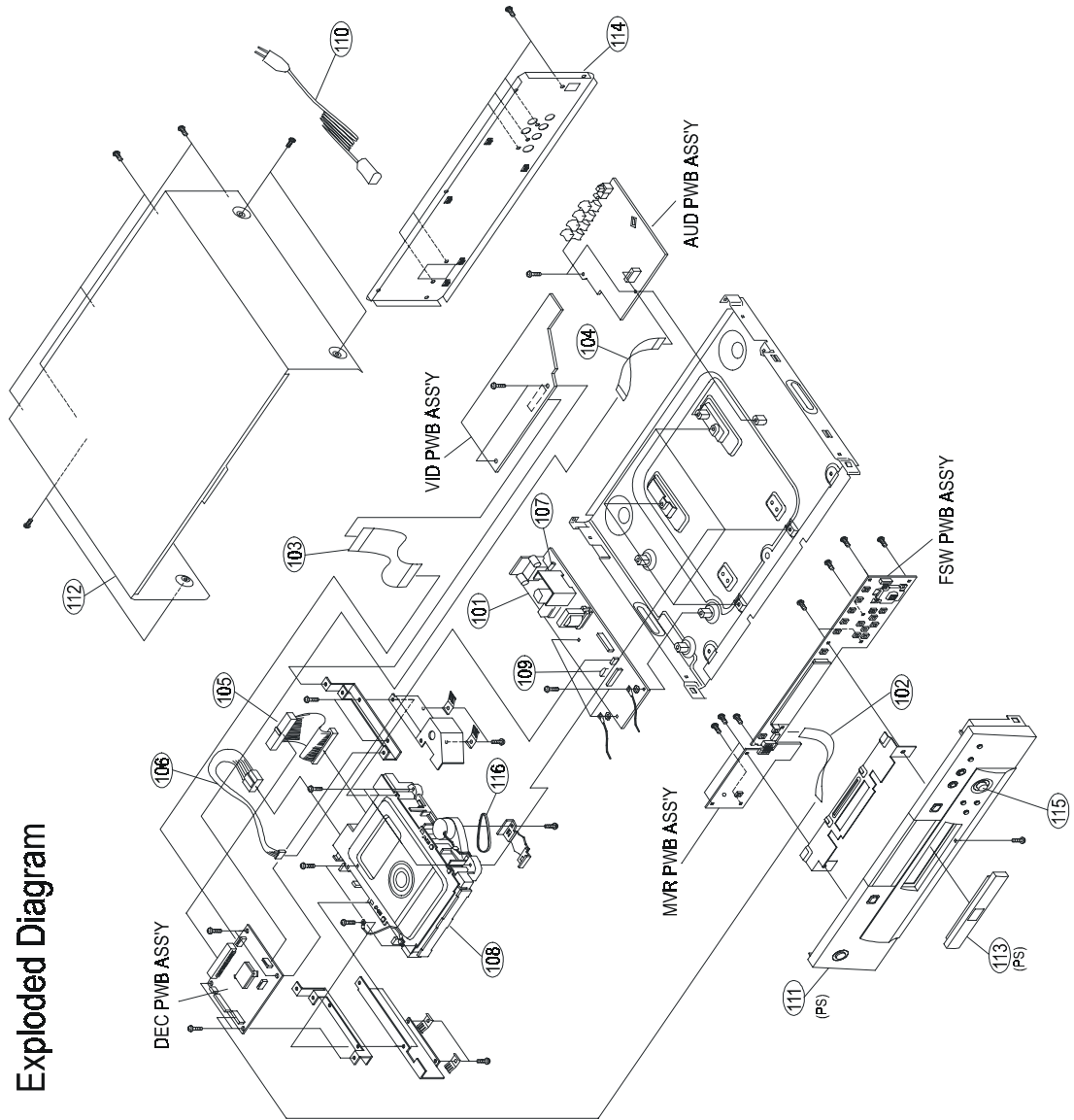

About System Reset Function

The player can not work normally with non-standard discs. If you encounter the abnormal status , please press **STOP** button once to stop it. If it can't stop normally, please press **POWER/STANDBY** button. If the status is not changed in about 20 seconds after pressing POWER/STANDBY button then just press **LAST** button and **ENTER** button concurrently on the front panel to reset the system. After resetting, the system will restart and change into standby mode (The POWER/STANDBY indicator lights in red color). Therefore, please press POWER/STANDBY button again to start the system. (Pull out the power cord and plug it again, the restarted system will also change into standby state.)

System Utility

How to upgrade the system utility

1. Power on the system and press the OPEN/CLOSE button to open the DVD-ROM tray.
2. Place the version-up CD-R disc into the DVD-ROM.
3. The DVD player will read the CD-R disc and upgrade the system utility version, after about 40 seconds, the DVD-ROM tray will open automatically.
4. Take out the version-up CD-R disc.
5. Pull out the power cord then plug it again.
6. Press the POWER/STANDBY button to restart the system, while the DVD-ROM tray closed, the version had been upgarded already.

NOTE: If the version of the system utility in the CD-R disk is older than original one, then the front display window will shows 'No play'.

How to check the system utility version

1. At the power on state, press the **POWER/STANDBY** button and **LAST** button once in the same time and then release the POWER/STANDBY button only and still press the LAST button continually for more than 5 seconds.
2. The front display window will appear the system utility version.

Removal and Replacement

This chapter contains step-by-step procedures on how to disassemble the consumer product for maintenance and troubleshooting.

To disassemble the computer, you need the following tools:

- Wrist grounding strap and conductive mat for preventing electrostatic discharge
- Flat-bladed screwdriver
- Phillips screwdriver
- Tweezers
- Flat-bladed screwdriver or plastic stick

NOTE: The screws for the different components vary in size. During the disassembly process, group the screws with the corresponding components to avoid mismatch when putting back the components.

General Information

Before You Begin

Before proceeding with the disassembly procedure, make sure that you do the following:

1. Turn off the power to the system and all peripherals.
2. Unplug the AC adapter and all power and signal cables from the system.

Disassembly Procedure Flowchart

The flowchart on the succeeding page gives you a graphic representation on the entire disassembly sequence and instructs you on the components that need to be removed during servicing. For example, if you want to remove the system board, you must first remove the keyboard, then disassemble the inside assembly frame in that order.

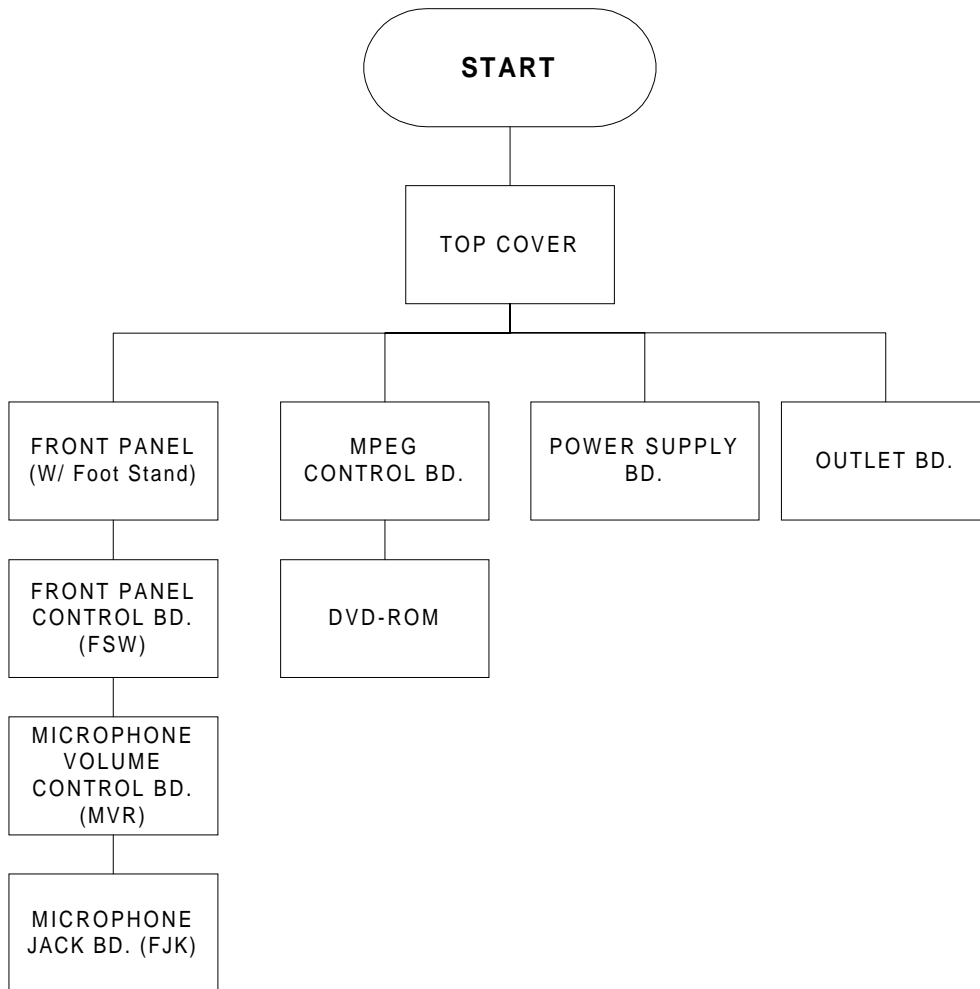

Disassembly Procedure

Removing the Top Cover

1. Remove two screws from each side of the machine and three screws from the rear side.



2. Use your hands to pull out the two sides of the top cover.



3. First, lift the top cover up lightly to release it from the front panel clicks, and then lift it up and move it away.



Removing the Foot Stand

1. Detach the screw from the foot stand and remove the foot stand.



Removing the Front Panel

1. Disconnect the three cables from the MPEG control board.
2. Disconnect one cable from the power supply board.

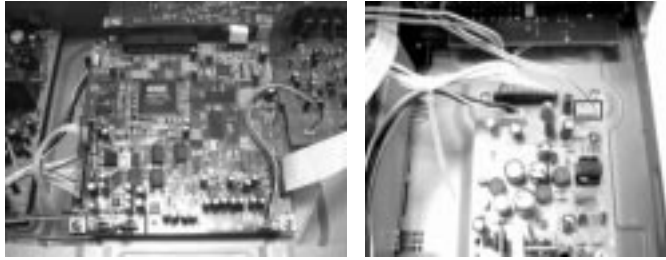

3. Turn the machine over to remove the screw at the bottom of the front panel.

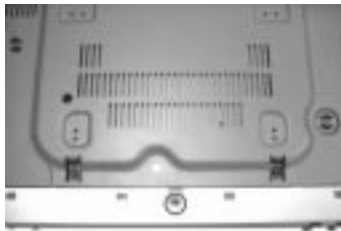

4. There is a plastic screw at the bottom side of the machine, use a screwdriver to slide the DVD-ROM tray out by turning the screw clockwise.



5. Use your fingers to slide up the DVD-ROM tray cover then push the tray back inside.



6. Detach the clicks on the bottom side and two sides of the machine.

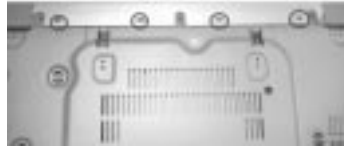

7. Pull the front panel out slightly.



Removing the MPEG Control Board

1. Disconnect the five cables and remove the four screws from the MPEG control board as shown below.
2. Remove the MPEG control board away.



Removing the Power Supply Board

1. Disconnect the two cables and three screws from the power supply board.
2. Remove the two screws of the power socket on the rear panel of the machine.



3. Slightly lift up the power supply board to remove it from the machine. .



Removing the DVD-ROM Drive

1. Detach the two screws on the daughter board and four screws from each side of the DVD-ROM drive and set it aside.



2. Disconnect the power cable and the IDE cable from the DVD-ROM drive.



-
3. Remove the four screws to detach the kitting part from top of the DVD-ROM drive.



4. Remove the four screws to detach the DVD-ROM shield and two EMI shields from the bottom of the DVD-ROM drive.



Removing the Outlet Board

1. Disconnect the two cables and remove the three screws from the outlet board.
2. Remove the eight screws from the rear panel of the machine.



3. Remove the outlet boards away.



Removing the Front Panel Control Boards

1. Remove the five screws from the front panel control board (FSW board).
2. Remove the three screws from the microphone volume control board (MVR board).

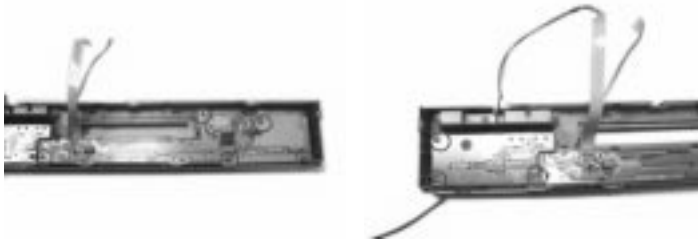

3. Slightly lift up the front panel control boards then separate the two boards by detaching the connection connector as shown below.

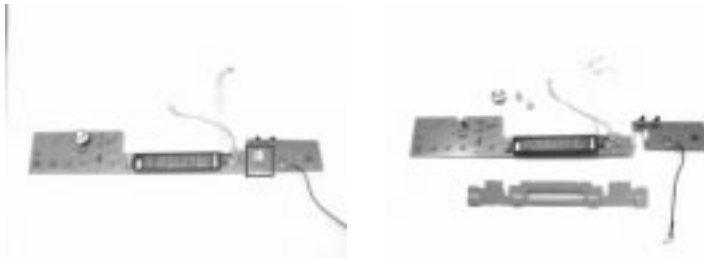

Connector Location

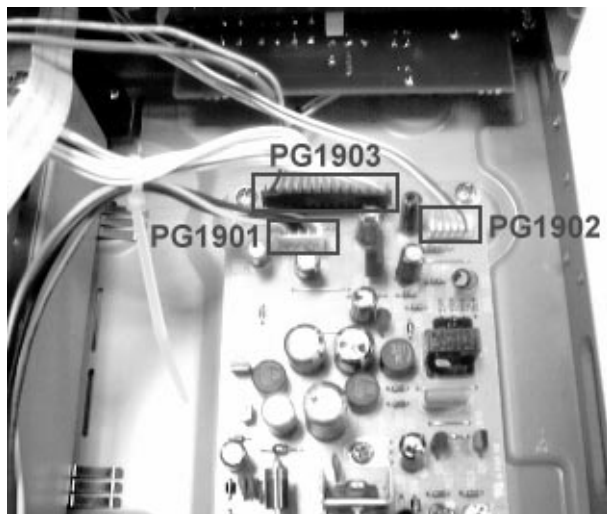
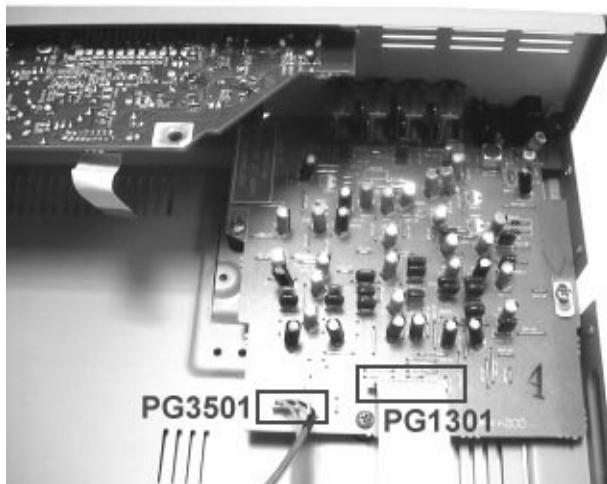

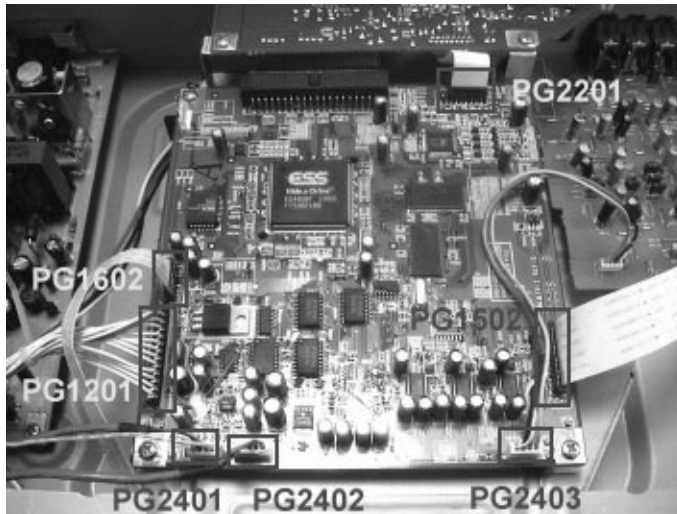

Schematics

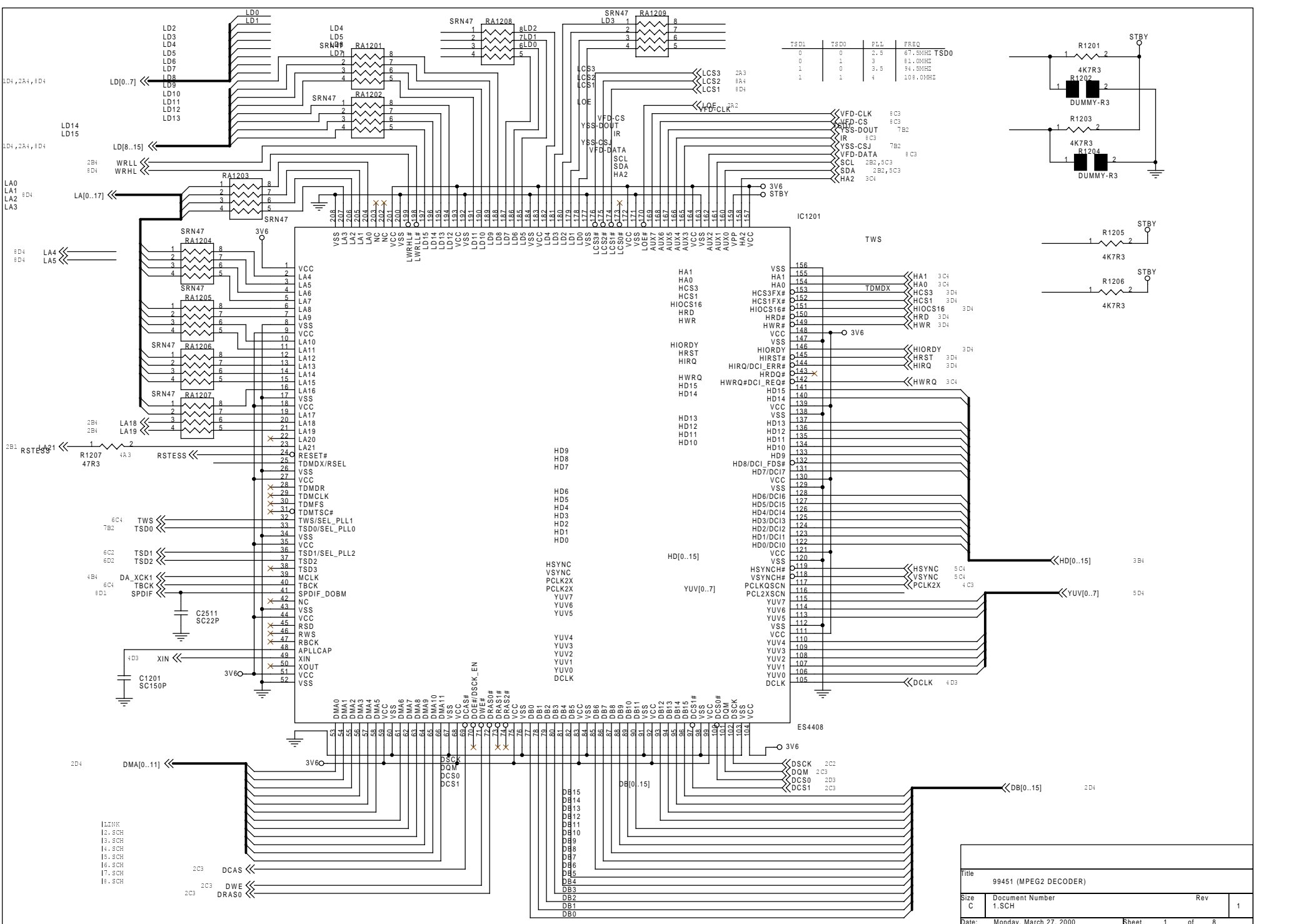

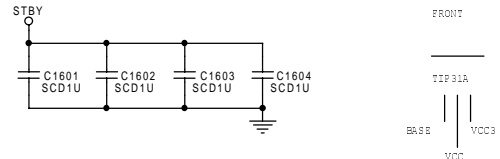
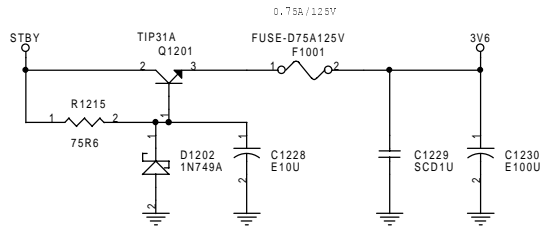
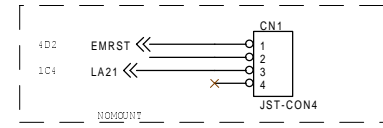
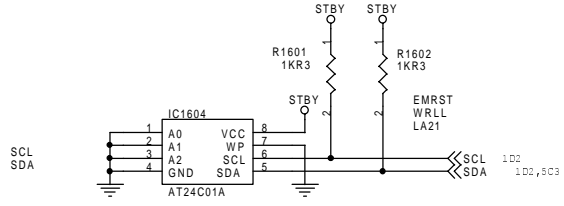
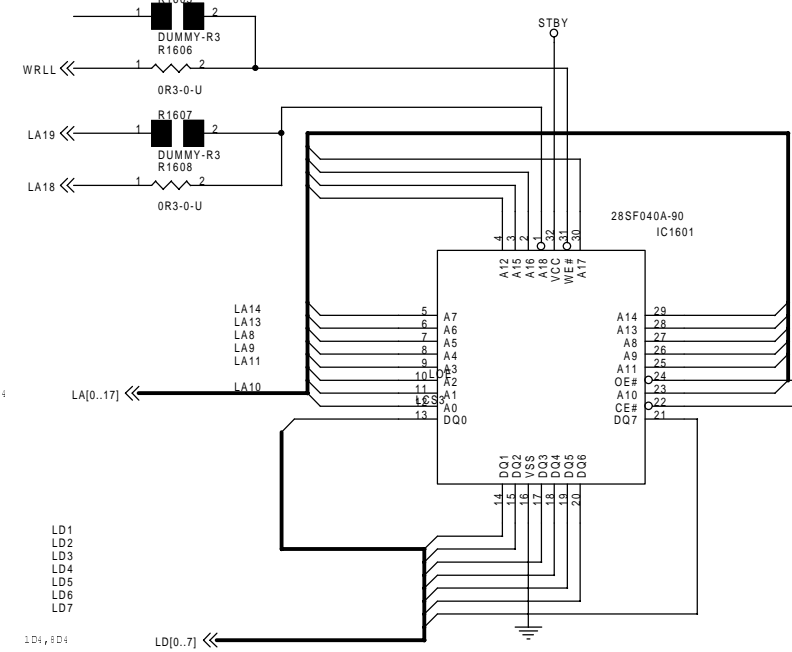
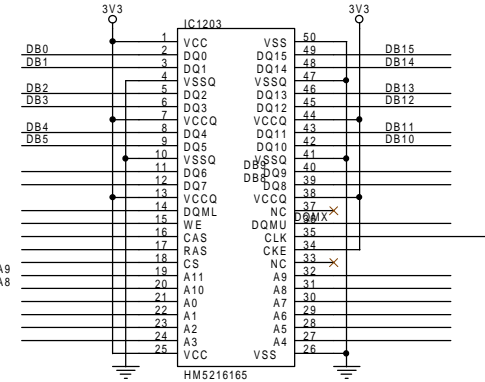
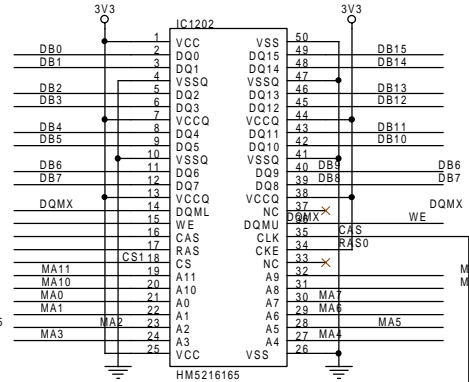
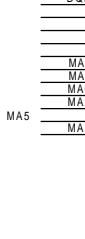
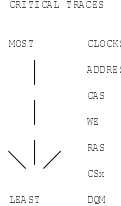
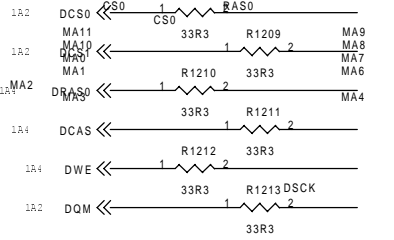
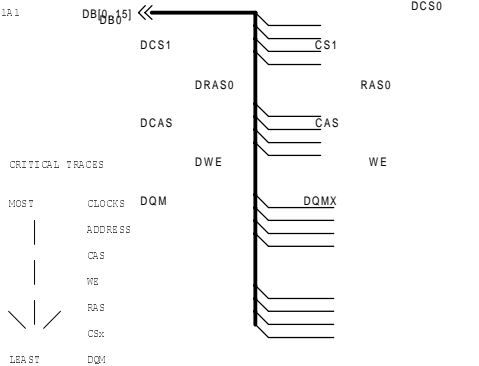
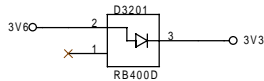
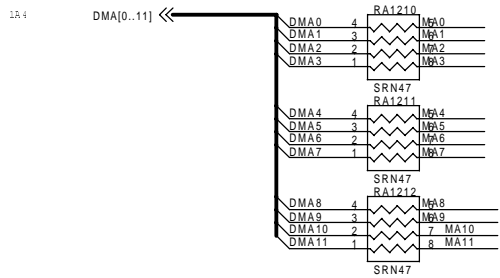

Title		
99451 (SDRAM & ROM EMULATOR)		
Size	Document Number	Rev
C	2.SCH	1
Date:	Monday, March 27, 2000	Sheet 2 of 8

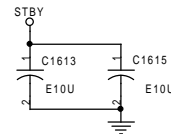
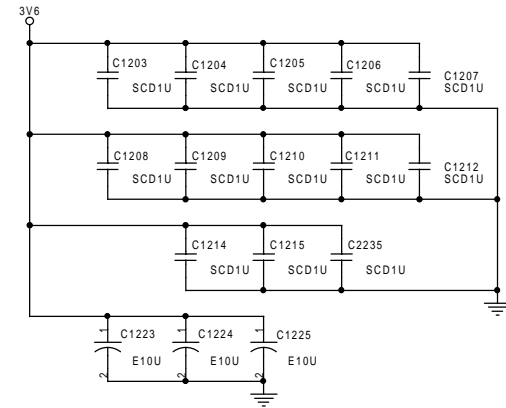
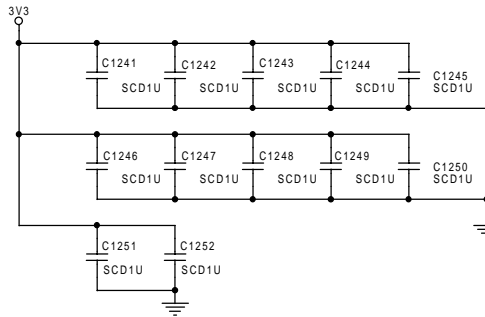
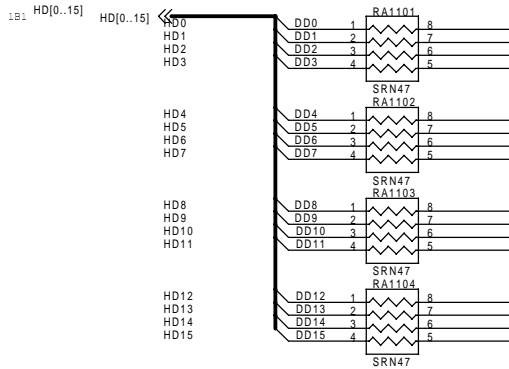
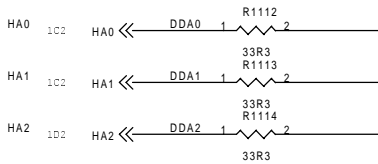
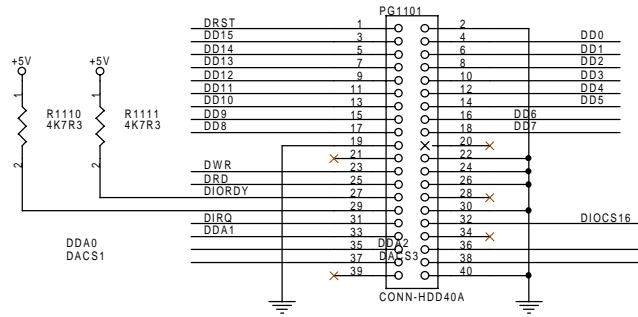
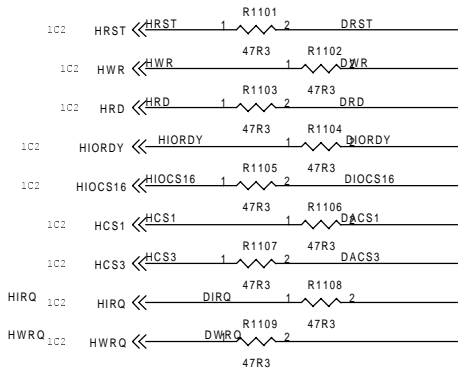

Title			
99451 (DVD DRIVE INTERFACE)			
Size	Document Number	Rev	1
C	3.SCH		
Date:	Monday, March 27, 2000	Sheet	3 of 8

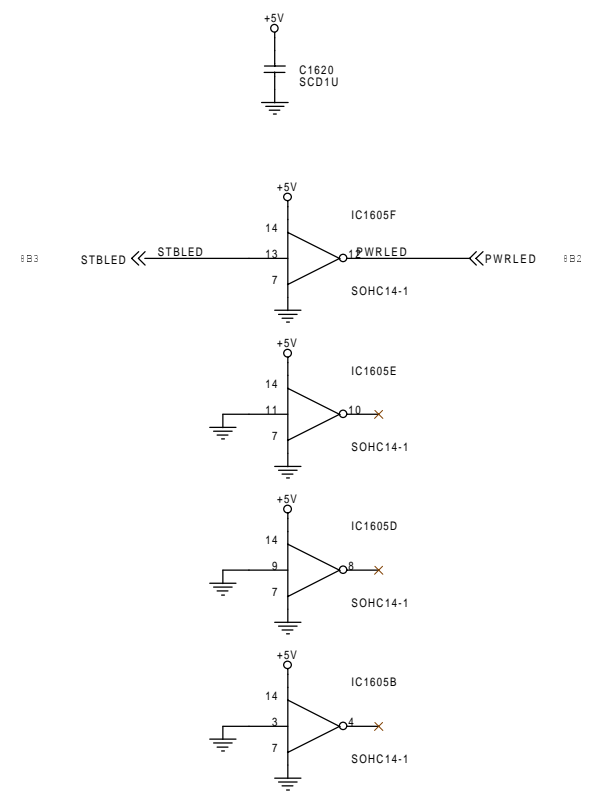
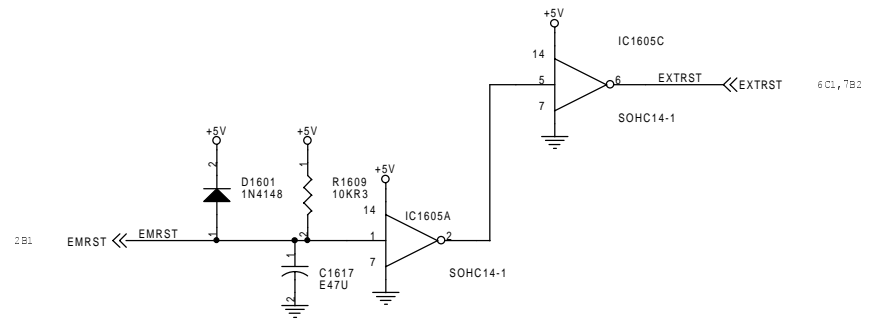
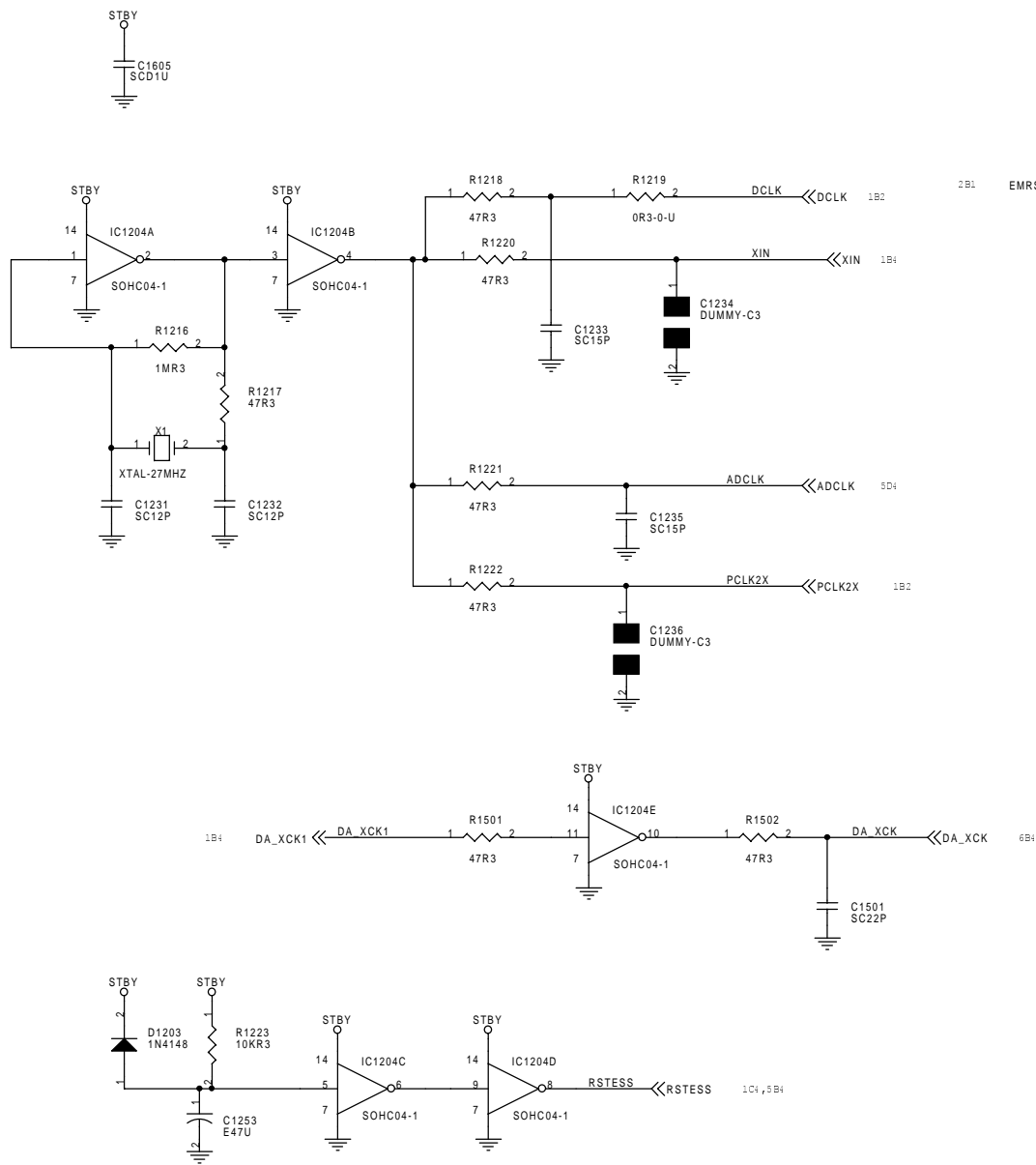

Title			
99451 (CLOCK & RESET CIRCUIT)			
Size	Document Number	Rev	1
C	4.SCH		
Date:	Monday, March 27, 2000	Sheet	4 of 8

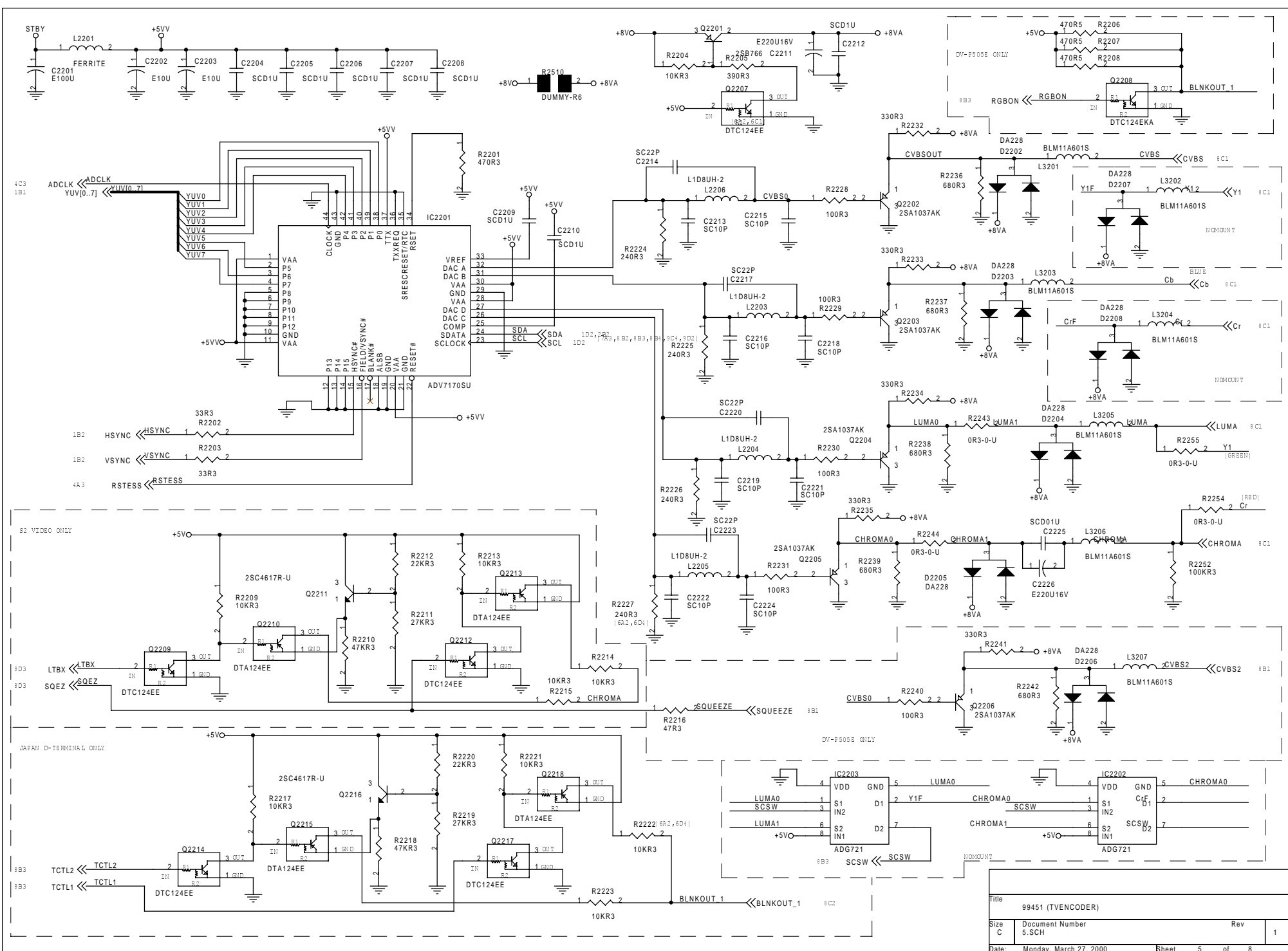

Title				99451 (TVENCODER)			
Size	Document Number			Rev	1		
C	5.SCH						
Date:	Monday, March 27, 2000		Sheet	5 of 8			

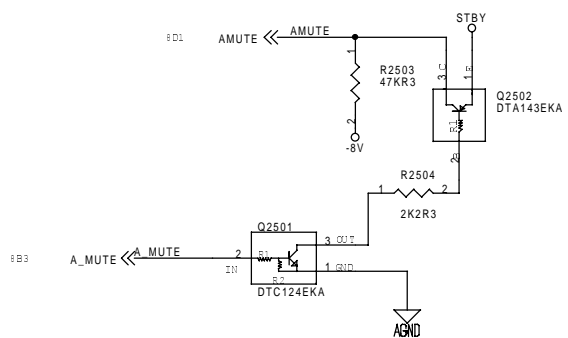
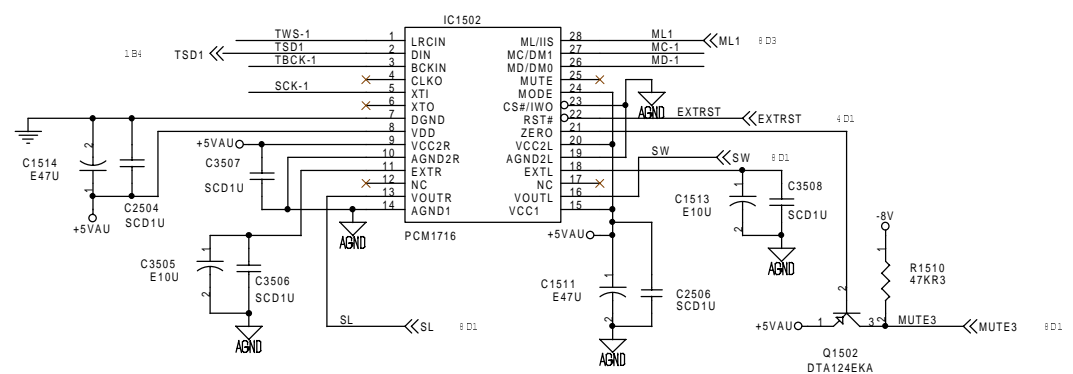
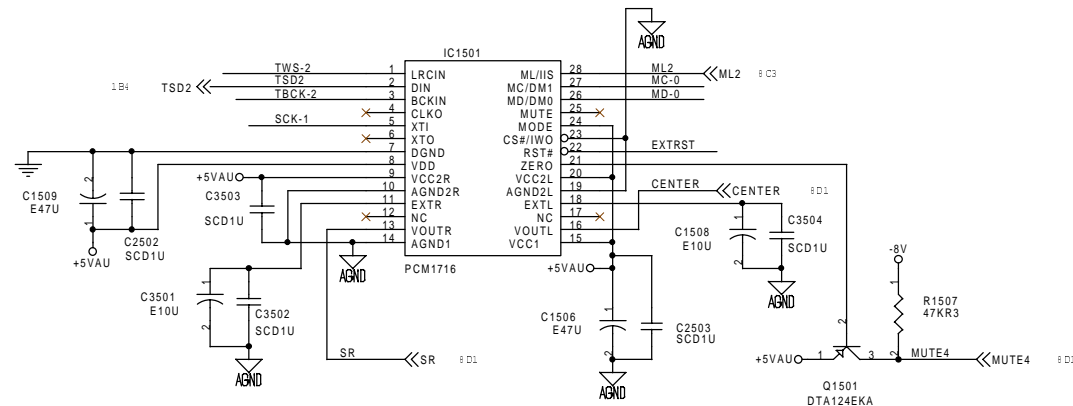
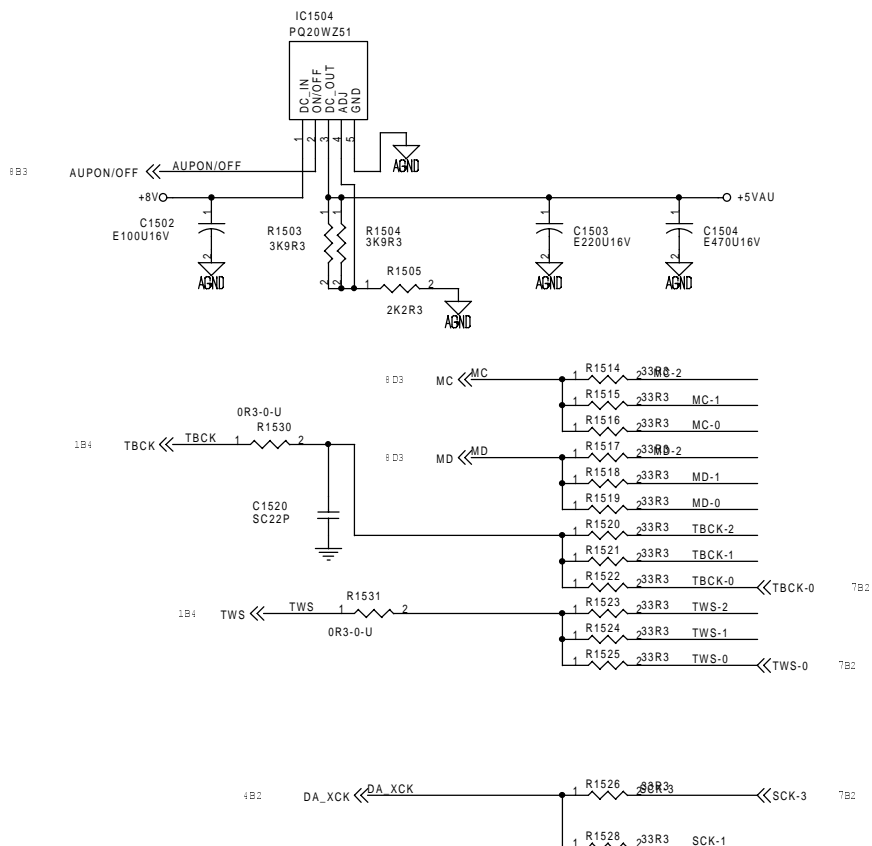

Title			
99451 (AUDIO DACS)			
Size	C	Document Number	6.SCH
		Rev	1
Date:	Monday, March 27, 2000	Sheet	6 of 8

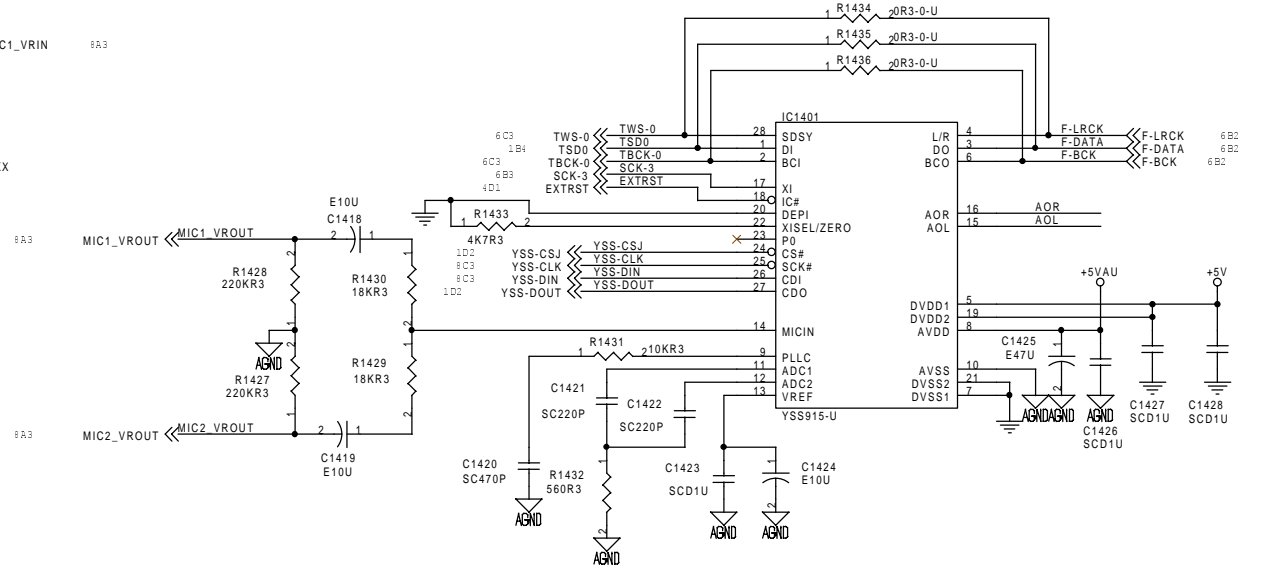
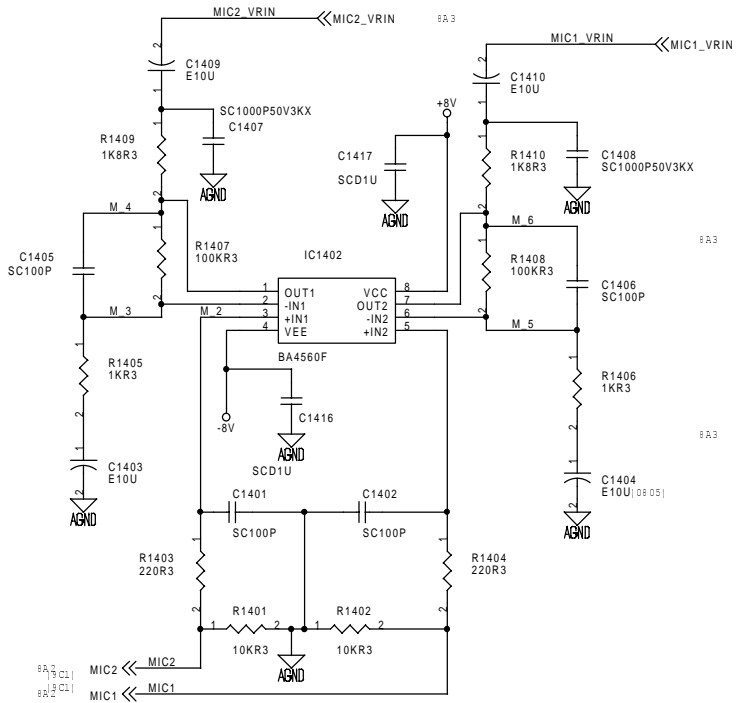
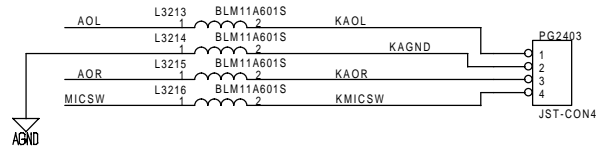
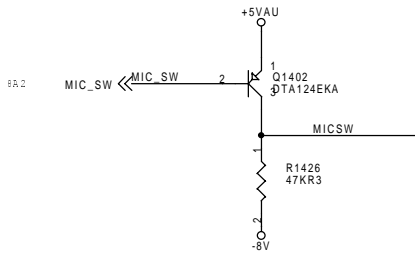

Title			
99451 (KARAOKE)			
Size	Document Number	Rev	1
C	7.SCH		
Date:	Monday, March 27, 2000	Sheet	7 of 8

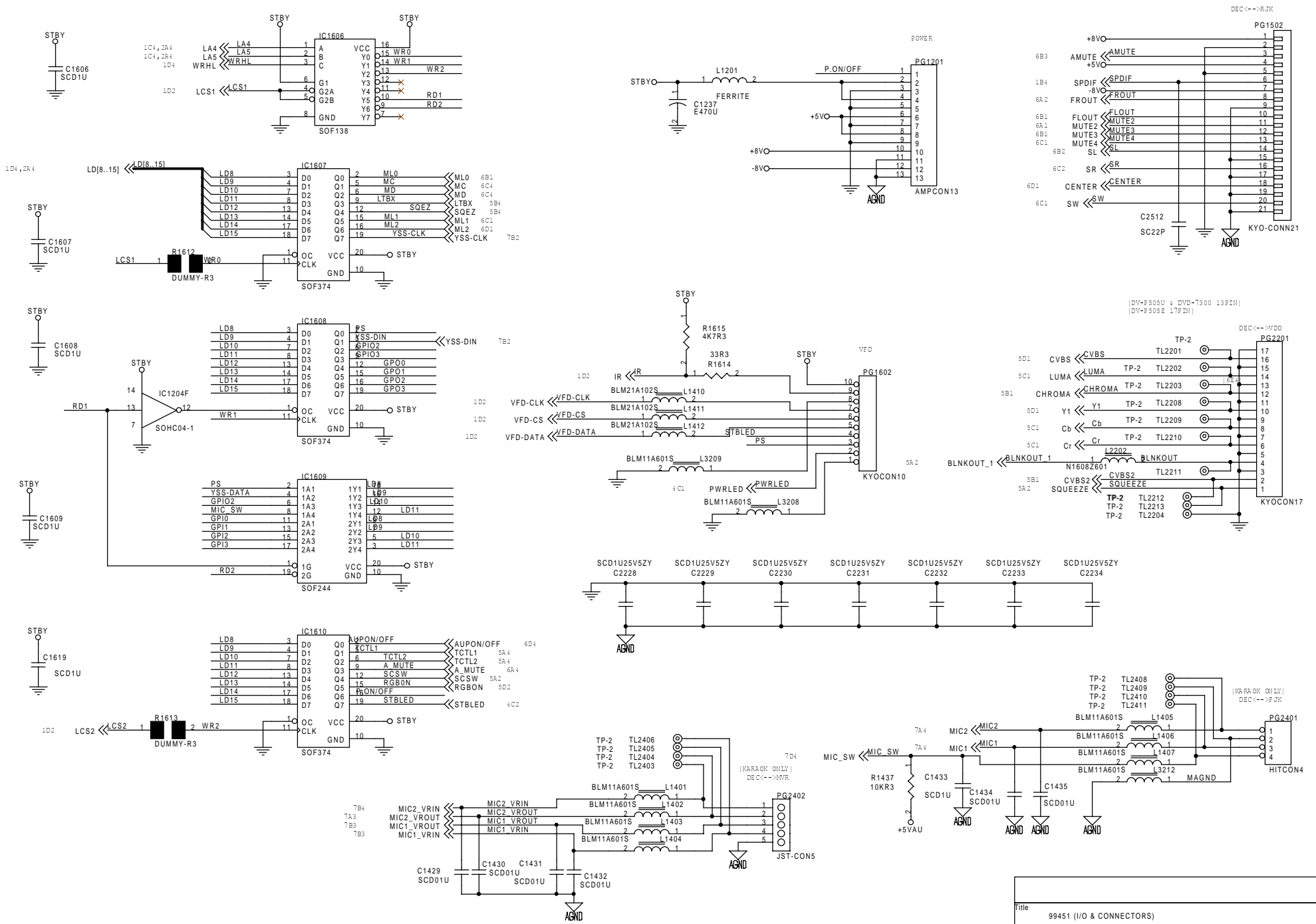

Title		99451 (I/O & CONNECTORS)	
Size	Document Number	Rev	1
C	8.SCH		
Date:	Monday, March 27, 2000	Sheet	8 of 8

LINK
2.SCH
3.SCH
4.SCH

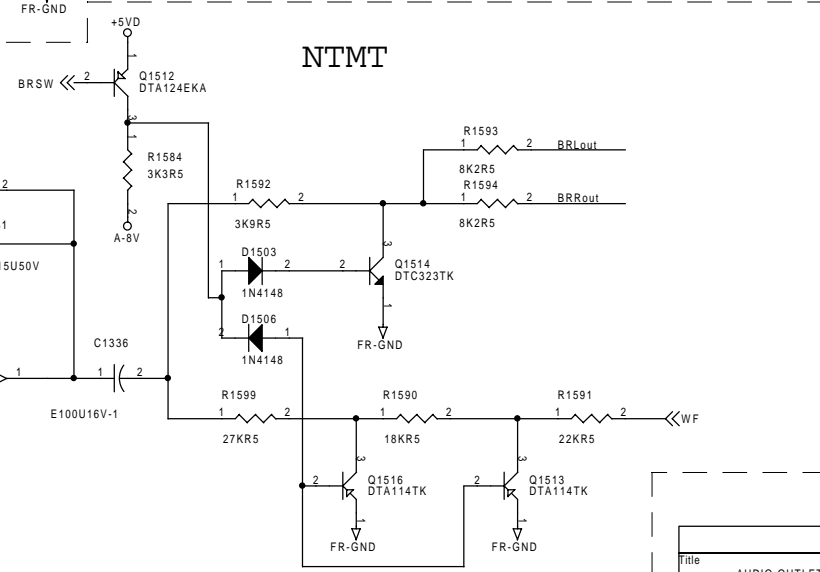
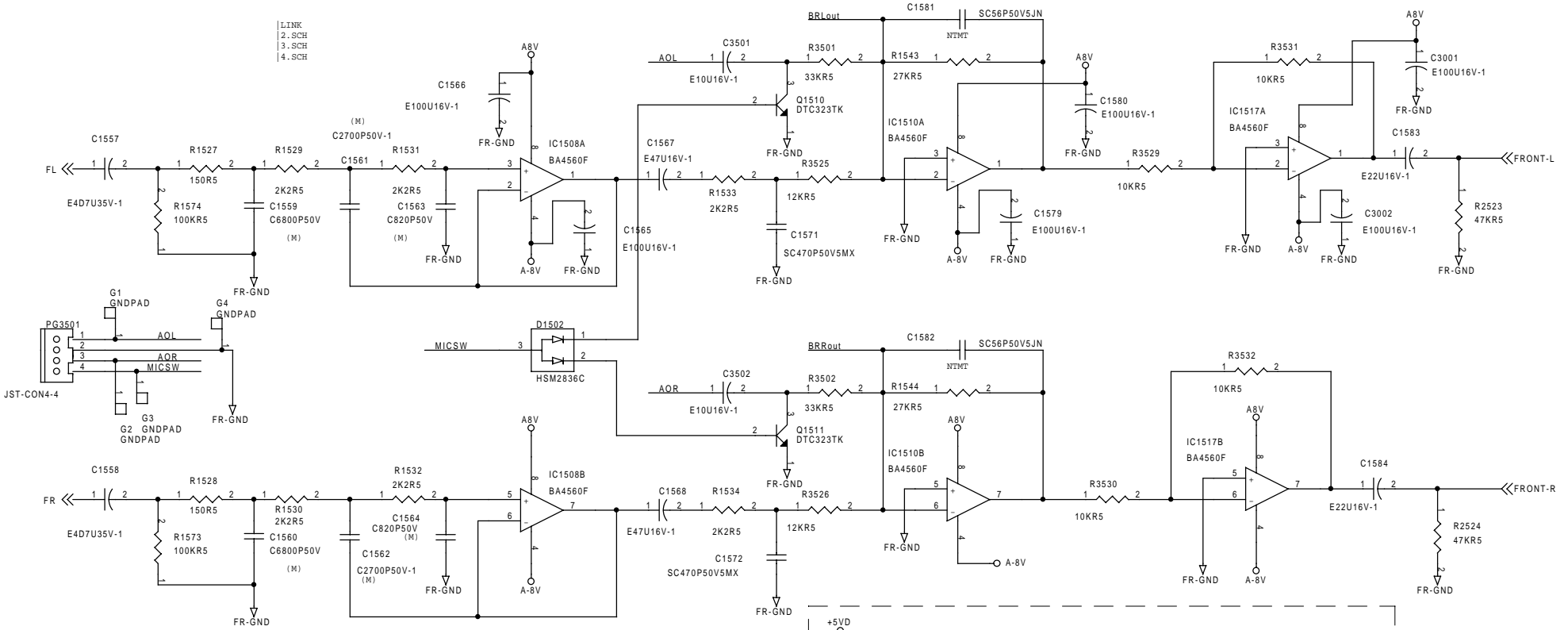

Title		
AUDIO OUTLET BD		
Size	Document Number	Rev
B		A
Date:	Wednesday, April 26, 2000	Sheet 1 of 4

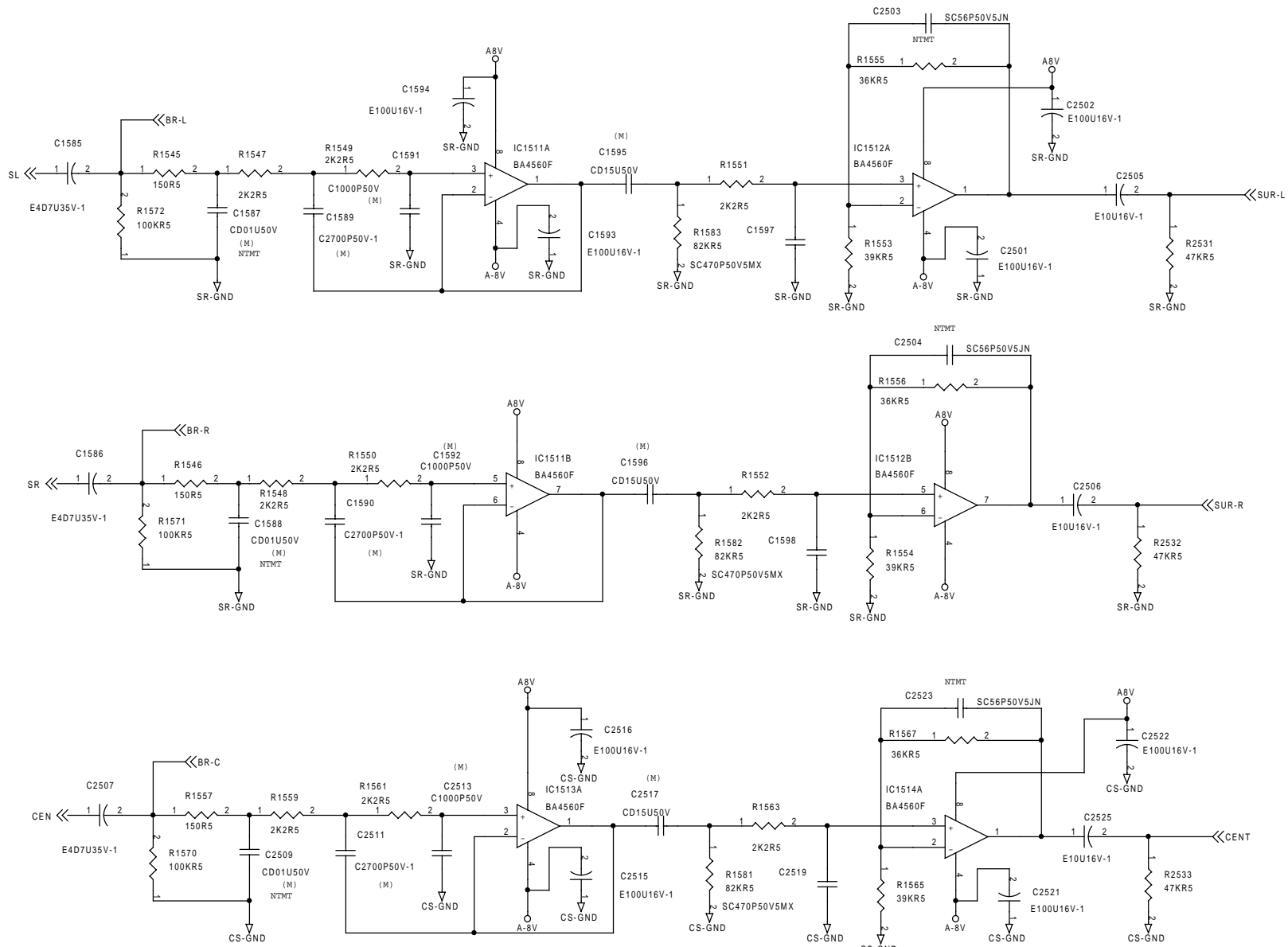

Title		
AUDIO OUTLET BD		
Size	Document Number	Rev
B		A
Date:	Wednesday, April 26, 2000	Sheet 2 of 4
		7

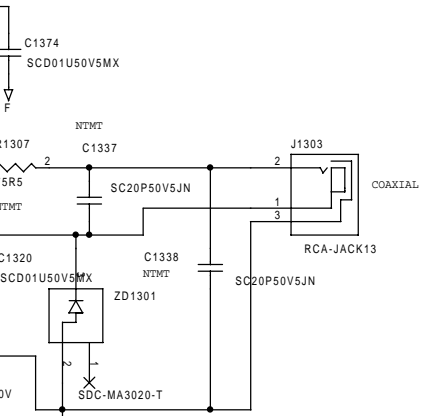
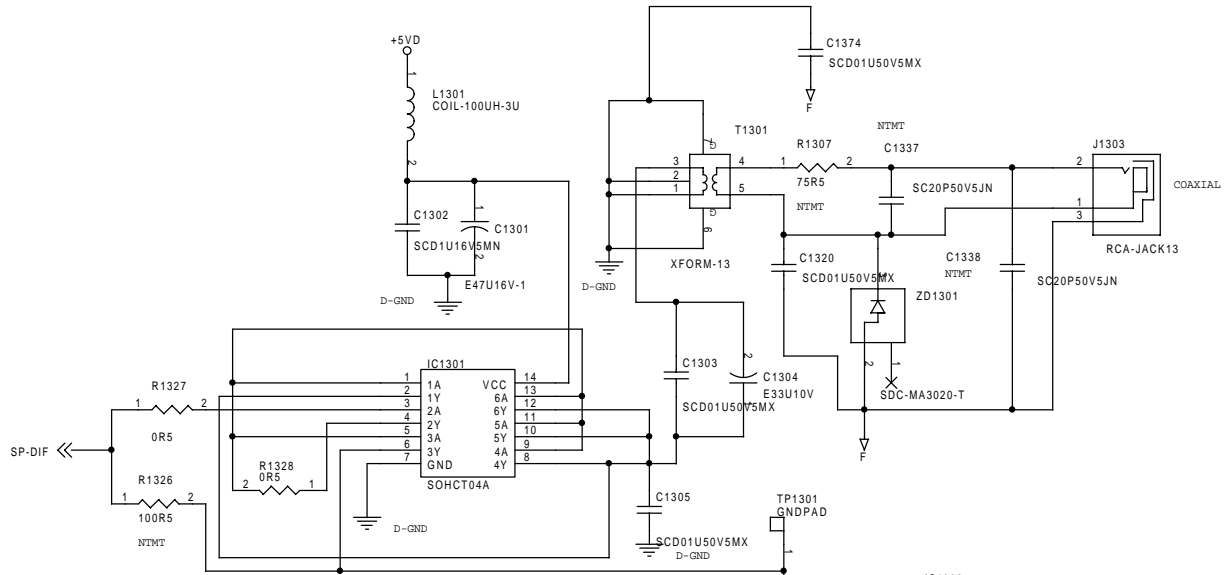
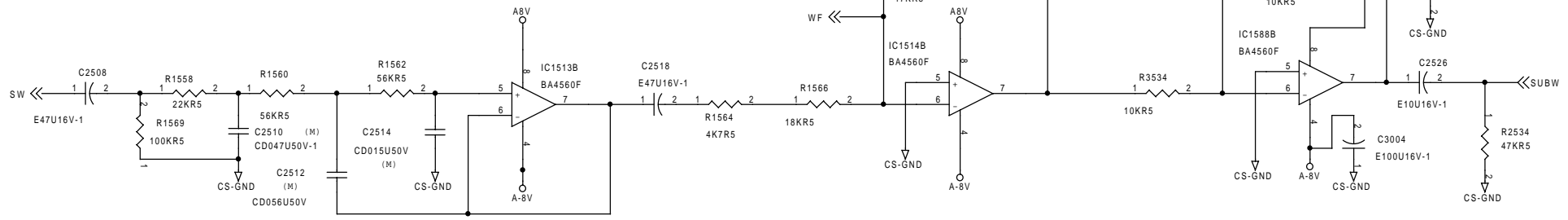
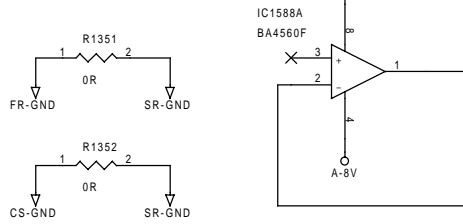
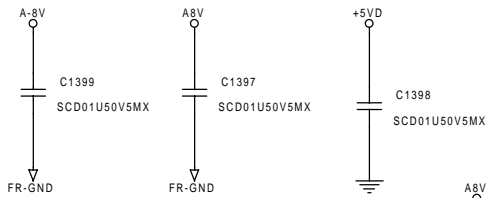
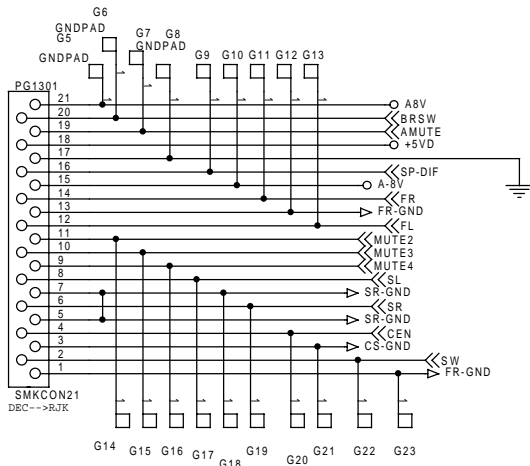

Title		
AUDIO OUTLET BD		
Size	Document Number	Rev
B		A
Date:	Wednesday, April 26, 2000	Sheet 3 of 4

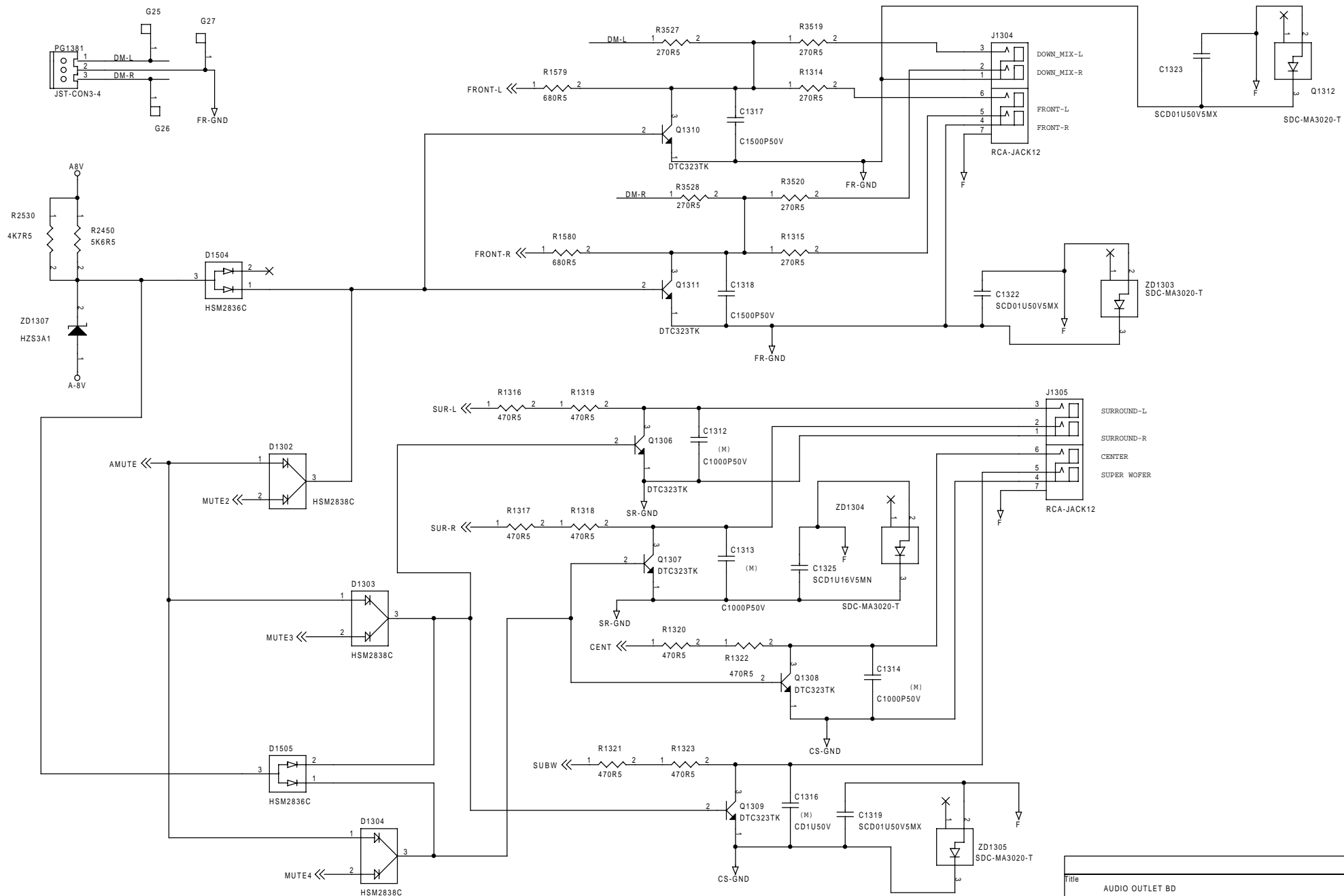

Title		
AUDIO OUTLET BD		
Size	Document Number	Rev
B		A
Date:	Wednesday, April 26, 2000	Sheet 4 of 4

MVR BOARD

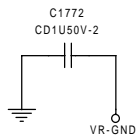
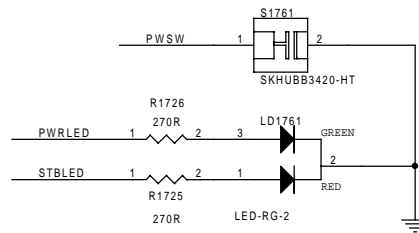
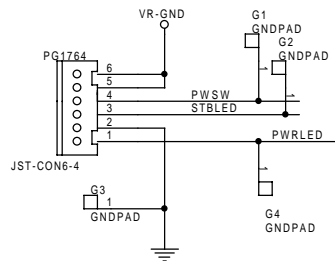

ACER CONSUMER			
Title		MIC BOARD	
Size	Document Number	Rev	SA
B		SA	
Date:	Monday, March 20, 2000	Sheet	1 of 1
	7		8

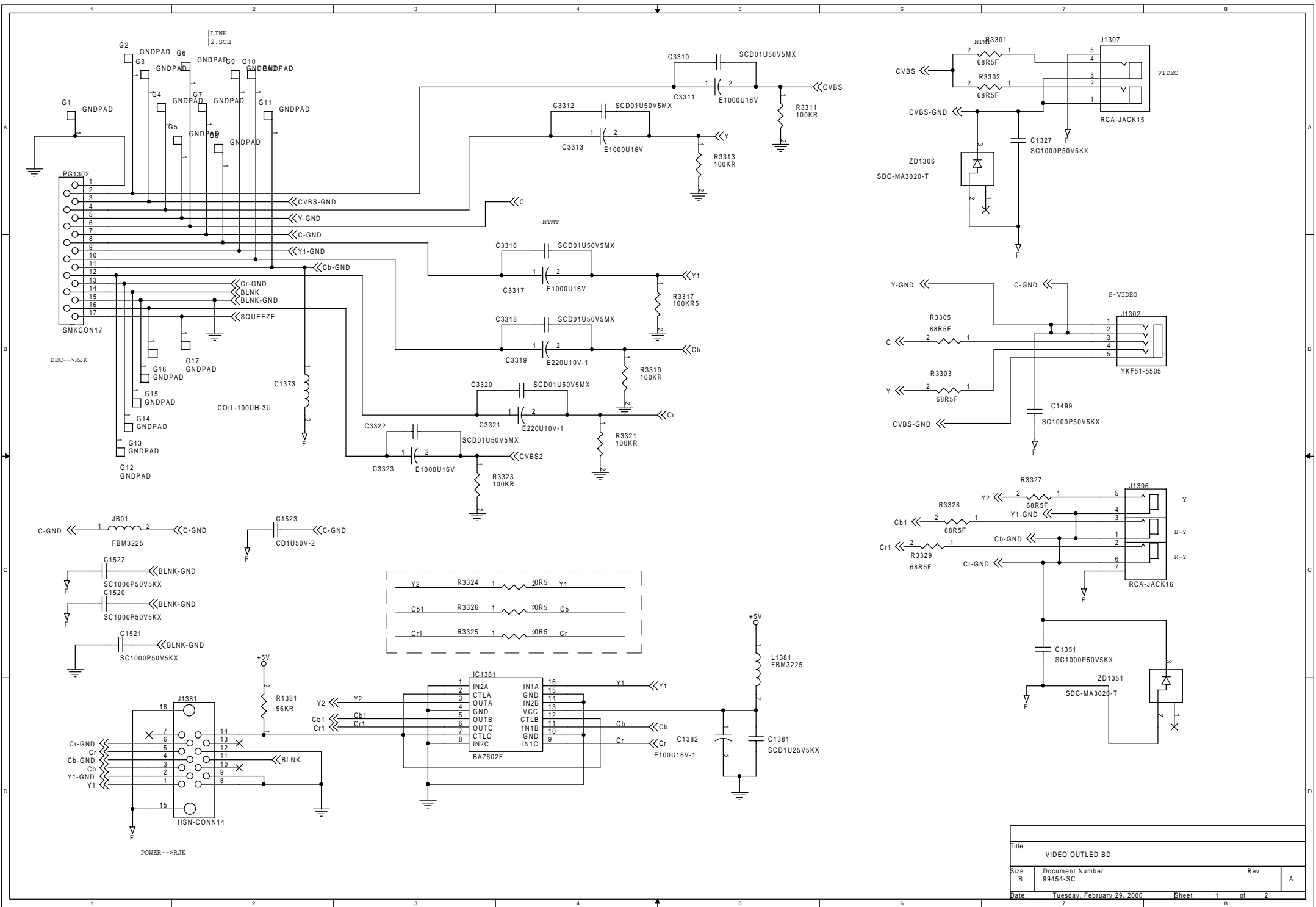

Title			VIDEO OUTLED BD		
Size	Document Number	Rev	A		
B	99454-SC				
Date:	Tuesday, February 29, 2000	Sheet	1	of	2

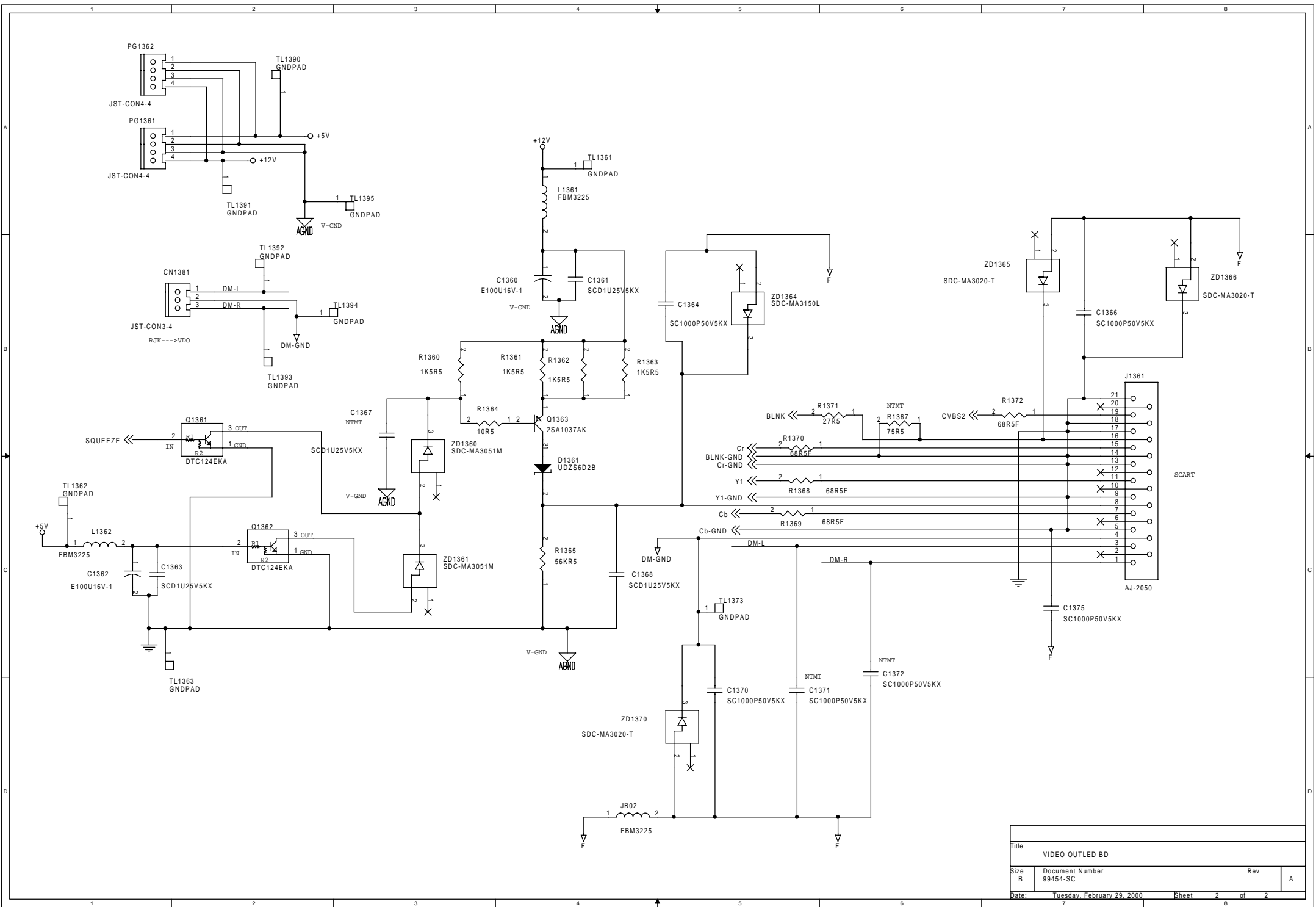

Title			VIDEO OUTLED BD		
Size	Document Number	Rev	A		
B	99454-SC				
Date:	Tuesday, February 29, 2000	Sheet	2	of	2

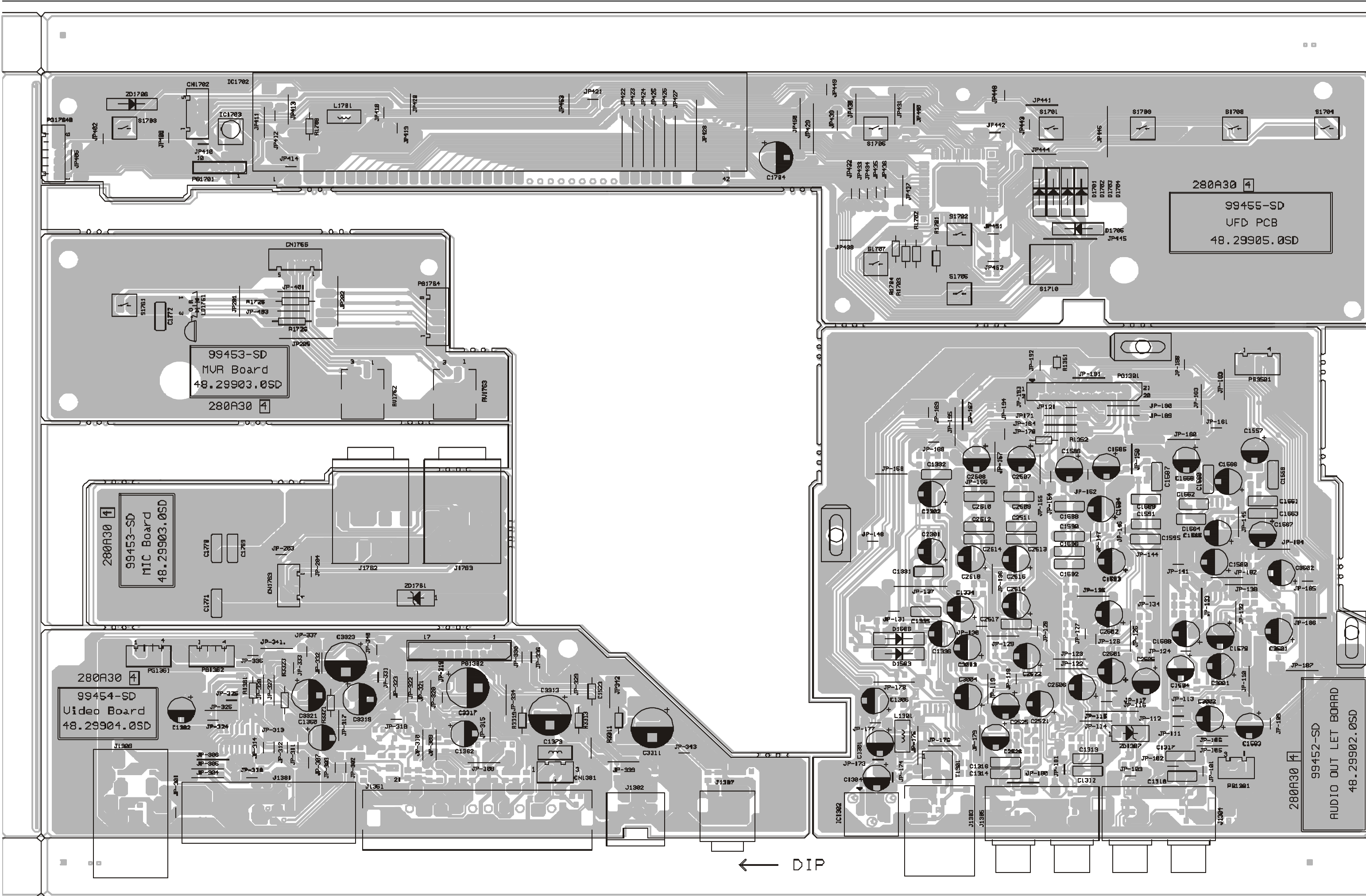

280A30 4
99455-SD
UFD PCB
48.29905.0SD

99453-SD
MVR Board
48.29903.0SD
280A30 4

280A30 4
99453-SD
MIC Board
48.29903.0SD

280A30 4
99454-SD
Video Board
48.29904.0SD

280A30 4
99452-SD
AUDIO OUT LET BOARD
48.29902.0SD

← DIP

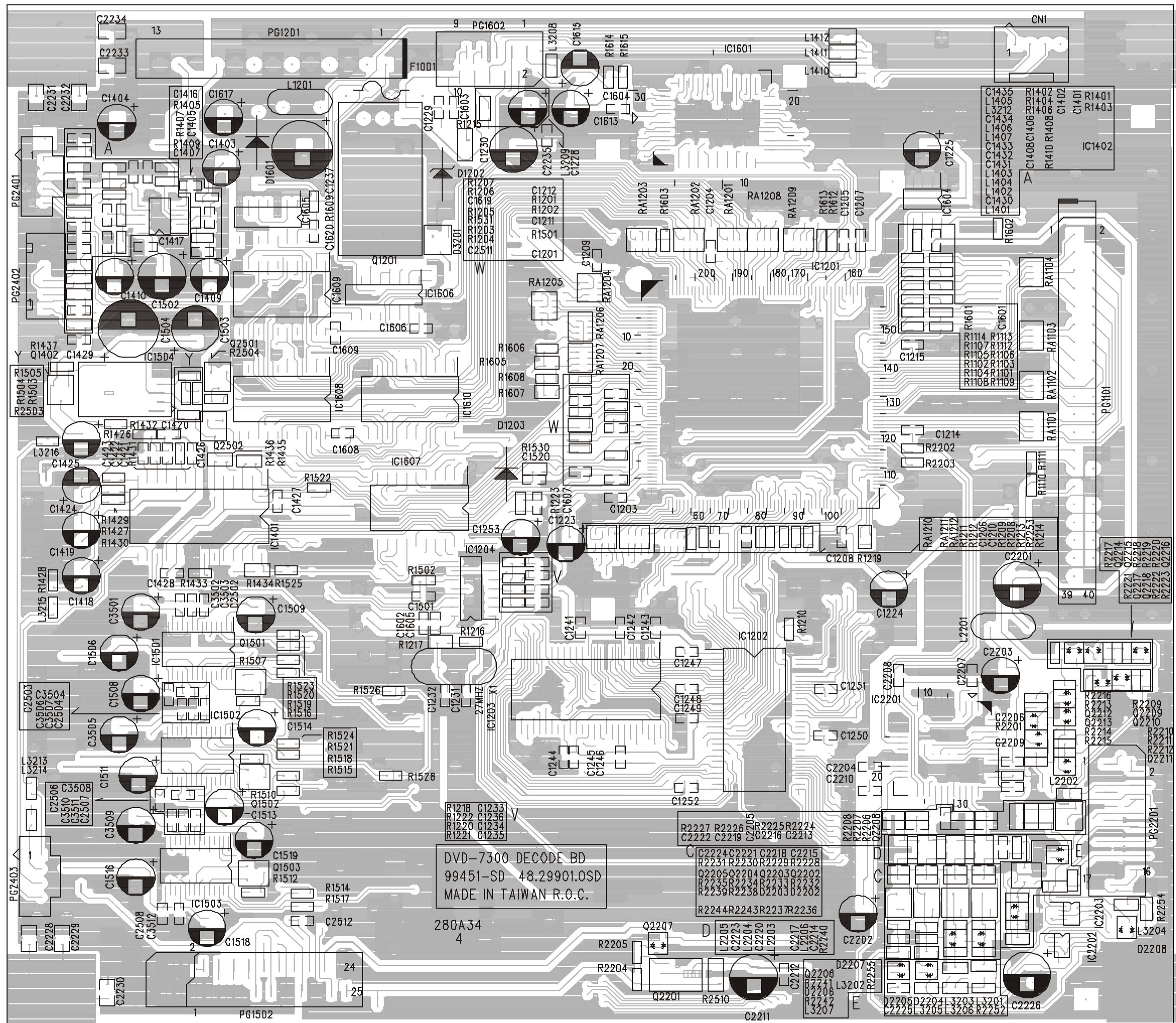

HITACHI

DV-P505U
DV-P505E
DV-P505E(UK)
DV-P505U(PX)

TK No. 9002E Digital Media Products Division, Tokai

Copyright© Hitachi, Ltd. 2000. All rights reserved.

Printed in TAIWAN