

HITACHI

SERVICE MANUAL

TK

No.9114E

DV-P515A(S)



SPECIFICATIONS AND PARTS ARE SUBJECT TO CHANGE FOR IMPROVEMENT

DVD PLAYER

August

2001

Digital Media Products Division, Tokai

CONTENTS

1. Precautions	1-1	No Tray open/close	5-4
1-1 Safety Precautions	1-1	CD/VCD/DVD L/R output error (Mixed Audio output)	5-5
1-2 Servicing Precautions	1-3	Digital output error	5-5
1-2-1 General Servicing Precautions	1-3	No Power(Standby LED OFF)	5-6
1-2-2 Insulation Checking Procedure	1-3	CVBS output error	5-6
1-3 ESD Precautions	1-4	S-Video output error	5-7
1-4 Handling the optical pick-up	1-5	Y/Pr/Pb output error	5-7
1-5 Pick-up disassembly and reassembly	1-6		
1-5-1 Disassembly	1-6	6. Exploded View	6-1
1-5-2 Assembly	1-6	6-1 Cabinet Assembly	6-1
		6-2 Deck Assembly	6-2
2. Product Specifications	2-1		
		7. Replacement Parts List	7-1
3. Operating Instructions	3-1	7-1 Mechanical Parts List	7-1
Description-Front Panel	3-1	7-2 Electrical Parts List	7-1
Front Panel Display	3-1		
Tour of the Remote Control	3-2	8. Block Diagram	8-1
Description-Rear Panel	3-3		
		9. PCB Diagrams	9-1
4. Disassembly and Reassembly	4-1	9-1 Main	9-1
4-1 Cabinet and PCB	4-1	9-2 Jack	9-2
4-1-1 Top Cabinet Removal	4-1	9-3 Key	9-3
4-1-2 Door-Tray Removal	4-2	9-4 Deck	9-3
4-1-3 Ass'y Front-Cabinet Removal	4-3	9-5 Housing	9-3
4-1-4 Ass'y Deck Removal	4-4		
4-1-5 Main PCB, Jack PCB Removal	4-5	10. Wiring Diagram	10-1
4-2 PCB Location	4-6		
4-3 Connector Diagram	4-7	11. Schematic Diagrams	11-1
4-4 Deck	4-8	Block Identification of PCB	11-1
4-4-1 Tray Disc Removal	4-8	11-1 Power	11-2
4-4-2 Ass'y P/U Deck Removal	4-9	11-2 AV-Decoder/Main-Micom	11-3
4-4-3 Housing Ass'y Removal	4-10	11-3 Servo	11-4
4-4-4 Sub Chassis Removal	4-11	11-4 Video	11-5
4-4-5 Ass'y Brkt Deck Removal	4-12	11-5 Audio	11-6
		11-6 Audio 5.1 Channel	11-7
5. Troubleshooting	5-1	11-7 Front-Micom/VFD Display	11-8
No Disc recognition	5-1	11-8 Headphon	11-9
No focus incoming	5-1	11-9 Key	11-10
No pick-up home positing	5-2	11-10 Deck	11-11
NO LD CD ON	5-2		
No Search Operation	5-3		
FINE SEEK Check	5-3		
Abnormal rotation of disc motor	5-4		

1. Precautions

1-1 Safety Precautions

1) Before returning an instrument to the customer, always make a safety check of the entire instrument, including, but not limited to, the following items:

(1) Be sure that no built-in protective devices are defective or have been defeated during servicing. (1) Protective shields are provided to protect both the technician and the customer. Correctly replace all missing protective shields, including any remove for servicing convenience.

(2) When reinstalling the chassis and/or other assembly in the cabinet, be sure to put back in place all protective devices, including, but not limited to, nonmetallic control knobs, insulating fish papers, adjustment and compartment covers/shields, and isolation resistor/capacitor networks. Do not operate this instrument or permit it to be operated without all protective devices correctly installed and functioning.

(2) Be sure that there are no cabinet openings through which adults or children might be able to insert their fingers and contact a hazardous voltage. Such openings include, but are not limited to, excessively wide cabinet ventilation slots, and an improperly fitted and/or incorrectly secured cabinet back cover.

(3) Leakage Current Hot Check-With the instrument completely reassembled, plug the AC line cord directly into a 110-240V AC outlet. (Do not use a isolation transformer during this test.) Use a leakage current tester or a metering system that complies with American National Standards institute (ANSI) C101.1 Leakage Current for Appliances and Underwriters Laboratories (UL) 1270 (40.7). With the instrument's AC switch first in the ON position and then in the OFF position, measure from a known earth ground (metal water pipe, conduit, etc.) to all exposed metal parts of the instrument (antennas, handle brackets, metal cabinets, screwheads, metallic overlays, control shafts, etc.), especially any exposed metal parts that offer an electrical return path to the chassis. Any current measured must not exceed 0.5mA. Reverse the instrument power cord plug in the outlet and repeat the test. See Fig. 1-1.

Any measurements not within the limits specified herein indicate a potential shock hazard that must be eliminated before returning the instrument to the customer.

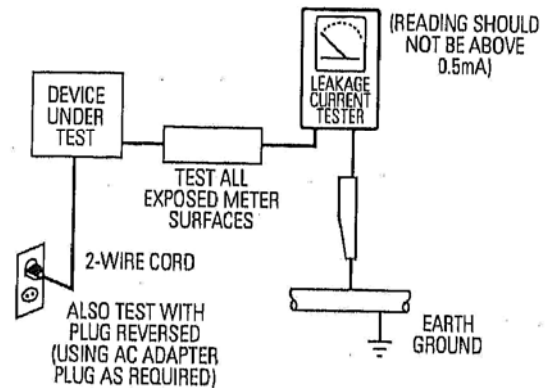

Fig. 1-1 AC Leakage Test

(4) Insulation Resistance Test Cold Check-(1) Unplug the power supply cord and connect a jumper wire between the two prongs of the plug. (2) Turn on the power switch of the instrument. (3) Measure the resistance with an ohmmeter between the jumpered AC plug and all exposed metallic cabinet parts on the instrument, such as screwheads, antenna, control shafts, handle brackets, etc. When an exposed metallic part has a return path to the chassis, the reading should be between 1 and 5.2 megohm. When there is no return path to the chassis, the reading must be infinite. If the reading is not within the limits specified, there is the possibility of a shock hazard, and the instrument must be re-pared and rechecked before it is returned to the customer. See Fig. 1-2.

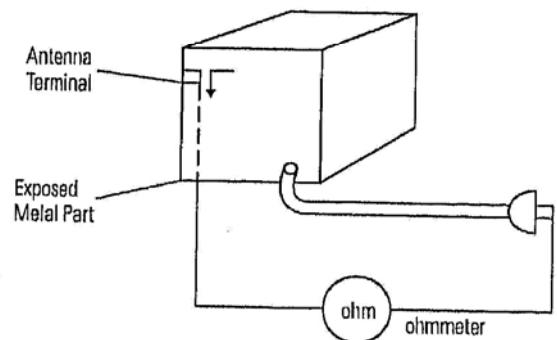

Fig. 1-2 Insulation Resistance Test

Precautions

- 2) Read and comply with all caution and safety related notes non or inside the cabinet, or on the chassis.
- 3) Design Alteration Warning-Do not alter or add to the mechanical or electrical design of this instrument. Design alterations and additions, including but not limited to, circuit modifications and the addition of items such as auxiliary audio output connections, might alter the safety characteristics of this instrument and create a hazard to the user. Any design alterations or additions will make you, the service, responsible for personal injury or property damage resulting therefrom.
- 4) Observe original lead dress. Take extra care to assure correct lead dress in the following areas:
(1) near sharp edges, (2) near thermally hot parts (be sure that leads and components do not touch thermally hot parts), (3) the AC supply, (4) high voltage, and (5) antenna wiring. Always inspect in all areas for pinched, out-of-place, or frayed wiring. Do not change spacing between a component and the printed-circuit board. Check the AC power cord for damage.
- 5) Components, parts, and/or wiring that appear to have overheated or that are otherwise damaged should be replaced with components, parts and/or wiring that meet original specifications. Additionally, determine the cause of overheating and/or damage and, if necessary, take corrective action to remove any potential safety hazard.
- 6) Product Safety Notice-Some electrical and mechanical parts have special safety-related characteristics which are often not evident from visual inspection, nor can the protection they give necessarily be obtained by replacing them with components rated for higher voltage, wattage, etc. Parts that have special safety characteristics are identified by shading, an (⚠) or a (⚡) on schematics and parts lists. Use of a substitute replacement that does not have the same safety characteristics as the recommended replacement part might create shock, fire and/or other hazards. Product safety is under review continuously and new instructions are issued whenever appropriate.

1-2 Servicing Precautions

CAUTION : Before servicing Instruments covered by this service manual and its supplements, read and follow the Safety Precautions section of this manual.

Note : If unforeseen circumvent create conflict between the following servicing precautions and any of the safety precautions, always follow the safety precautions. Remember: Safety First.

1-2-1 General Servicing Precautions

- (1) a. Always unplug the instrument's AC power cord from the AC power source before (1) re-moving or reinstalling any component, circuit board, module or any other instrument assembly, (2) disconnecting any instrument electrical plug or other electrical connection, (3) connecting a test substitute in parallel with an electrolytic capacitor in the instrument.
- b. Do not defeat any plug/socket B+ voltage interlocks with which instruments covered by this service manual might be equipped.
- c. Do not apply AC power to this instrument and /or any of its electrical assemblies unless all solid-state device heat sinks are correctly installed.
- d. Always connect a test instrument's ground lead to the instrument chassis ground before connecting the test instrument positive lead. Always remove the test instrument ground lead last.

Note : Refer to the Safety Precautions section ground lead last.

- (2) The service precautions are indicated or printed on the cabinet, chassis or components. When servicing, follow the printed or indicated service precautions and service materials.
- (3) The components used in the unit have a specified flame resistance and dielectric strength. When replacing components, use components which have the same ratings. Components identified by shading, by (\triangle) or by (\triangle) in the circuit diagram are important for safety or for the characteristics of the unit. Always replace them with the exact replacement components.

(4) An insulation tube or tape is sometimes used and some components are raised above the printed wiring board for safety. The internal wiring is sometimes clamped to prevent contact with heating components. Install such elements as they were.

(5) After servicing, always check that the removed screws, components, and wiring have been installed correctly and that the portion around the serviced part has not been damaged and so on. Further, check the insulation between the blades of the attachment plug and accessible conductive parts.

1-2-2 Insulation Checking Procedure

Disconnect the attachment plug from the AC outlet and turn the power ON. Connect the insulation resistance meter (500V) to the blades of the attachment plug. The insulation resistance between each blade of the attachment plug and accessible conductive parts(see note) should be more than 1 Megohm.

Note : Accessible conductive parts include metal panels, input terminals, earphone jacks, etc.

1-3 ESD Precautions

Electrostatically Sensitive Devices (ESD)

Some semiconductor (solid state) devices can be damaged easily by static electricity.

Such components commonly are called Electrostatically Sensitive Devices(ESD). Examples of typical ESD devices are integrated circuits and some field-effect transistors and semiconductor chip components. The following techniques should be used to help reduce the incidence of component damage caused by static electricity.

- (1) Immediately before handling any semiconductor component or semiconductor-equipped assembly, drain off any electrostatic charge on your body by touching a known earth ground. Alternatively, obtain and wear a commercially available discharging wrist strap device, which should be removed for potential shock reasons prior to applying power to the unit under test.
- (2) After removing an electrical assembly equipped with ESD devices, place the assembly on a conductive surface such as aluminum foil, to prevent electrostatic charge buildup or exposure of the assembly.
- (3) Use only a grounded-tip soldering iron to solder or unsolder ESD devices.
- (4) Use only an anti-static solder removal devices. Some solder removal devices not classified as "anti-static" can generate electrical charges sufficient to damage ESD devices.
- (5) Do not use freon-propelled chemicals. These can generate electrical charges sufficient to damage ESD devices.
- (6) Do not remove a replacement ESD device from its protective package until immediately before your are ready to install it.(Most replacement ESD devices are packaged with leads electrically shorted together by conductive foam, aluminum foil or comparable conductive materials).

- (7) Immediately before removing the protective materials from the leads of a replacement ESD device, touch the protective material to the chassis or circuit assembly into which the device will be installed.

CAUTION : Be sure no power is applied to the chassis or circuit, and observe all other safety precautions.

- (8) Minimize bodily motions when handling unpackaged replacement ESD devices. (Otherwise harmless motion such as the brushing together of your clothes fabric or the lifting of your foot from a carpeted floor can generate static electricity sufficient to damage an ESD device).

1-4 Handling the optical pick-up

The laser diode in the optical pick up may suffer electrostatic breakdown because of potential static electricity from clothing and your body.

The following method is recommended.

- (1) Place a conductive sheet on the work bench (The black sheet used for wrapping repair parts.)
- (2) Place the set on the conductive sheet so that the chassis is grounded to the sheet.
- (3) Place your hands on the conductive sheet (This gives them the same ground as the sheet.)
- (4) Remove the optical pick up block
- (5) Perform work on top of the conductive sheet. Be careful not to let your clothes or any other static sources to touch the unit.
 - ◆ Be sure to put on a wrist strap grounded to the sheet.
 - ◆ Be sure to lay a conductive sheet made of copper etc. Which is grounded to the table.

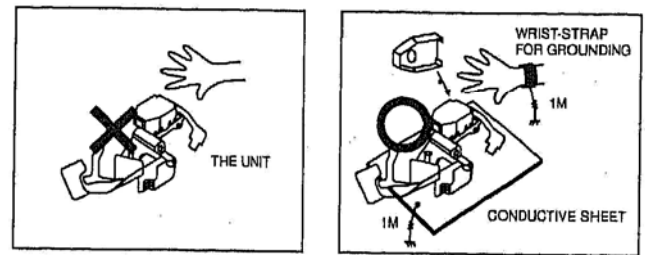

Fig.1-3

- (6) Short the short terminal on the PCB, which is inside the Pick-Up ASS'Y, before replacing the Pick-Up. (The short terminal is shorted when the Pick-Up Ass'y is being lifted or moved.)
- (7) After replacing the Pick-up, open the short terminal on the PCB.

1-5 Pick-up disassembly and reassembly

1-5-1 Disassembly

- 1) Remove the power code.
- 2) Disassemble the Deck-Assy.
- 3) Solder land 4 points short on Pick-up.(See Fig. 1-4)
- 4) Disassembly the Pick-up.

1-5-2 Assembly

- 1) Replace the Pick-up.
- 2) Remove the soldering 4 points on Pick-up.
- 3) Reassemble the Deck-Assy.

Note : If the assembly and disassembly are not done in correct sequence, the Pick-up may be damaged.

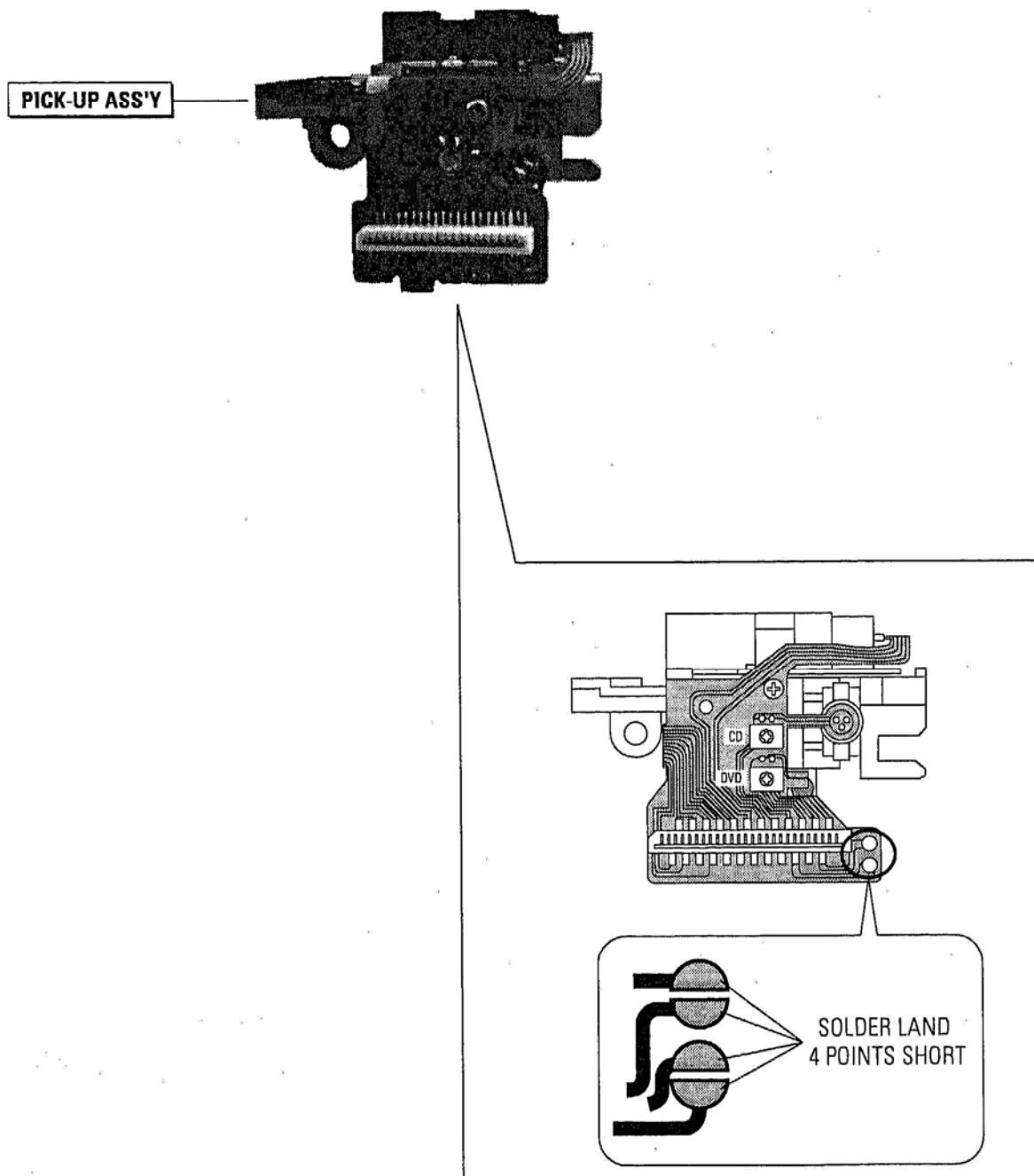

Fig. 1-4

2. Product Specifications

GENERAL	Power Requirements	AC 110-240V, 50/60Hz	
	Power Consumption	15W	
	Weight	2.7kg	
	Dimensions	W 430mm x D 240mm x H 79mm	
	Operating Temperature Range	+5° C to +35° C	
	Operating Humidity Range	10% to 75%	
DISC	DVD (Digital Versatile Disc)	Reading Speed : 3.49 m/s Approx. Play Time (Single Sided, Single Layer Disc) : 135 min.	
	CD : 12cm (Compact Disc)	Reading Speed : 1.2 to 1.4 m/s Maximum Play Time : 74min.	
	CD : 8cm (Compact Disc)	Reading Speed : 1.2 to 1.4 m/s Maximum Play Time : 20min.	
	VCD : 12cm	Reading Speed : 1.2 to 1.4 m/s Maximum Play Time : 74min. (Video + Audio)	
	Video Output	Composite Video	1 channel : 1.0Vp-p (75ohm load)
		Component jack	Y : 1.0Vp-p (75ohm load)
Pr : 0.70Vp-p (75ohm load)			
Pb : 0.70Vp-p (75ohm load)			
S-Video	Luminance Signal : 1Vp-p (75ohm load) Chrominance Signal : 0.286Vp-p (75ohm load)		
Audio Output	Mixed 2ch output	2 systems (pin jack x 2)	
	5.1ch output	1 system (pin jack x 6)	
	* Frequency Response	48kHz Sampling : 4Hz to 22kHz	
		96kHz Sampling : 4Hz to 44kHz	
	* S/N Ratio	110dB	
	* Dynamic Range	100dB	
* Total Harmonic Distortion	0.004%		
Other Terminals	Digital Audio output	Optical connector: 1	
		Coaxial terminal: 1	
	Dolby Digital Out	PCM/Bitstream	
	MPEG2 Digital Out	PCM/Bitstream	
DTS	Off/On		

* : Nominal specification

MEMO

0.000000 0.000000

3. Operating Instructions

Description-Front Panel

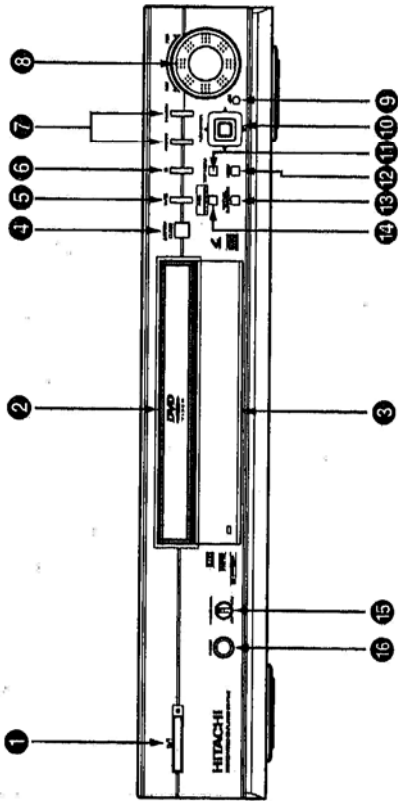

Front Panel Controls

- 1 **⏻/1 (POWER/STANDBY)**
 - When the unit is first plugged in, the indicator lights. When $\phi/1$ (POWER/STANDBY) is pressed, the lamp goes out and the player is turned on.
- 2 **DISC TRAY**
 - Press \blacktriangle OPEN/CLOSE to open and close the disc tray.
- 3 **DISPLAY**
 - Operation indicators are displayed here.
- 4 **▲ OPEN/CLOSE**
 - Press to open and close the disc tray.
- 5 **▶/|| (PLAY/PAUSE)**
 - Begin or pause disc play.
- 6 **■ (STOP)**
 - Stops disc play.
- 7 **◀/▶ (SKIP/SEARCH)**
 - Use to skip a scene or music.
 - If this button is held down for approx. two seconds, it will switch to the search button. Thereafter, each time the button is pressed, the search speed will switch to 2X, 4X, 8X, 16X, 32X, 128X, after which SKIP will be restored.
- 8 **Jog/Shuttle dial**
 - MENU
 - Brings up the Menu on a disc.
 - Jog
 - To switch between the shuttle dial and jog dial.
- 9 **Cursor**
 - Moves the cursor and determines its position.
 - Pressing the center will deliver entering functions.
- 10 **Top MENU**
 - Brings up the Top Menu on a disc.
- 11 **PHONES jack**
 - Connect headphones, etc. for private listening.
- 12 **VIRTUAL SURROUND**
 - To activate the 3D sound.
- 13 **DISC NAVIGATION**
 - To view the first picture of each chapter(DVD) or track(VCD).
- 14 **PHONES LEVEL**
 - To adjust the level of sound output from phones jack.

Front Panel Display

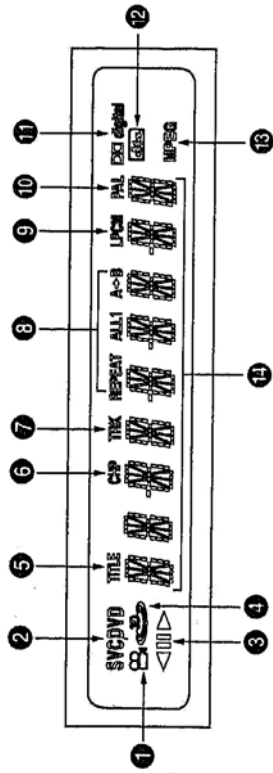

Front Panel Display

- 1 You can now select different viewing points of the scene recorded by different cameras (Multi Angle).
- 2 Disc type indicators
- 3 Reverse playback / Pause / Forward playback
- 4 Lights when 3D sound is turned on.
- 5 DVD : Title number
- 6 DVD : Chapter number.
- 7 Video/Audio CD : Track number
- 8 Repeat play mode
- 9 Linear PCM audio output
- 10 PAL indicator
- 11 Dolby Digital audio output
- 12 DTS (Digital Theater System) audio output(Digital only)
- 13 MPEG-2 Audio output
- 14 Displays various messages concerning operations such as PLAY, STOP, LOAD, RANDOM, ...
- 15 no DISC : No disc loaded.
- 16 OPEN : The disc tray is open.
- 17 LOAD : Player is loading disc information.

Tour of the Remote Control

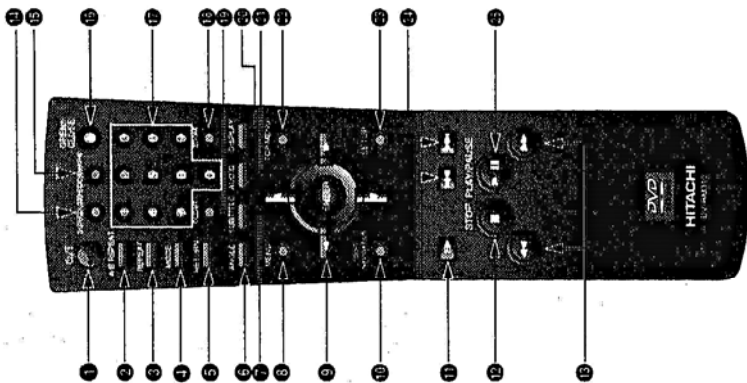

Tour of the Remote Control

DVD Function Buttons

- 1 **POWER/STANDBY Button**
 - Turns the player on and off.
- 2 **A-B REPEAT Button**
 - Marks a segment to repeat between A and B.
- 3 **REPEAT Button**
 - Allows you to repeat play a title, chapter, track, or disc.
- 4 **MODE Button**
 - Allows you to program a specific order.
- 5 **RETURN Button**
 - Returns to a previous menu.
- 6 **ANGLE Button**
 - Accesses various camera angles on a disc.
- 7 **SUBTITLE Button**
 - Accesses various subtitles on a disc.
- 8 **MENU Button**
 - Brings up the Menu on a disc.
- 9 **ENTER/DIRECTION Button (UP/DOWN or LEFT/RIGHT Button)**
- 10 **DISC NAVIGATION Button**
 - To view the first picture of each chapter(DVD) or track(VCD).
- 11 **STEP Button**
 - Advances playback one frame at a time.
- 12 **STOP Button**
 - To stop playback.
- 13 **SEARCH Buttons**
 - Allows you to search forward/backward through a disc.
- 14 **SURROUND Button**
 - To activate the 3D sound.
- 15 **BOOKMARK Button**
 - To rapidly return to a location of disc.
- 16 **OPEN/CLOSE Button**
 - To open or close the disc tray.
- 17 **NUMBER Buttons**
- 18 **ZOOM Button**
 - To magnify part of picture.
- 19 **CLEAR Button**
 - Removes menus or status displays from the screen.
- 20 **DISPLAY Button**
 - Displays the current disc mode.
- 21 **AUDIO Button**
 - Accesses various audio functions on a disc.
- 22 **TOP MENU Button**
 - Brings up the Top Menu on a disc.
- 23 **SETUP Button**
 - Brings up the DVD player's Setup menu.
- 24 **SKIP Buttons**
 - Skip the, Chapter, or Track.
- 25 **PLAY/PAUSE Button**
 - Begin/Pause disc play.

How to handle the remote control

- Operate the remote control within the following area, in a straight line from the signal detecting eye of the player and an angle of 30°.

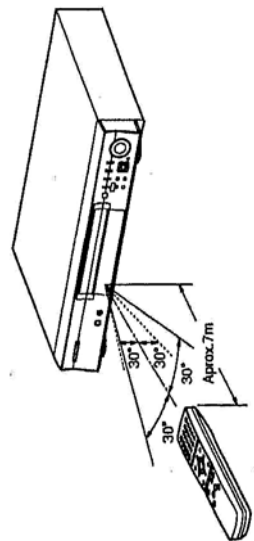

Description-Rear Panel

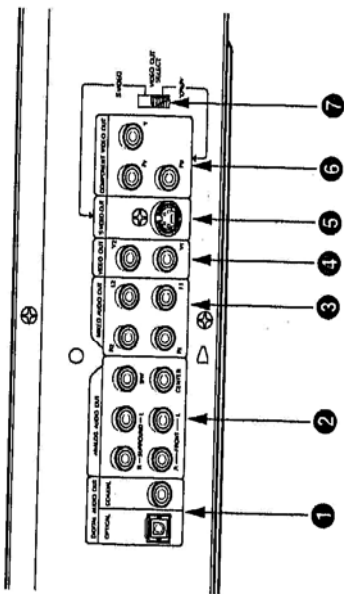

Rear Panel

- 1 DIGITAL AUDIO OUT JACK**

 - Use either an optical or coaxial digital cable to connect to a compatible Dolby Digital receiver. Use to connect to an AV Amplifier that contains a Dolby Digital decoder or DTS decoder.
- 2 5.1CH ANALOG AUDIO OUT JACKS**

 - Connect to an amplifier with 5.1ch analog input jacks.
- 3 MIXED AUDIO OUT JACKS**

 - Connect to the Audio input jacks of your television, audio/video receiver.
- 4 VIDEO OUT JACKS**

 - Use a video cable to connect one of the jack to the Video input on your television.
- 5 S-VIDEO OUT JACK**

 - Use the S-Video cable to connect this jack to the S-Video jack on your television for a higher quality picture. The S-Video must be selected in the VIDEO OUT SELECT switch.
- 6 COMPONENT VIDEO OUT JACKS**

 - Use these jacks if you have a TV with Component Video in jacks. These jacks provide Pr, Pb and Y video. Along with S-Video, Component Video provides the best picture quality. The Y, Pb, Pr must be selected in the VIDEO OUT SELECT switch.
- 7 VIDEO OUT SELECT SWITCH**

 - Use the switch to set video out.
 - If the Y, Pb or Pr is selected, the S-Video may not work.
 - If the S-Video is selected, the Y, Pb or Pr may not work.

MEMO

4. Disassembly and Reassembly

4-1 Cabinet and PCB

Note : Reassembly in reverse order.

4-1-1 Top Cabinet Removal

- 1) Remove 3 Screws ❶ on the back Top Cabinet.
- 2) Lift up the Top Cabinet in direction of arrow.

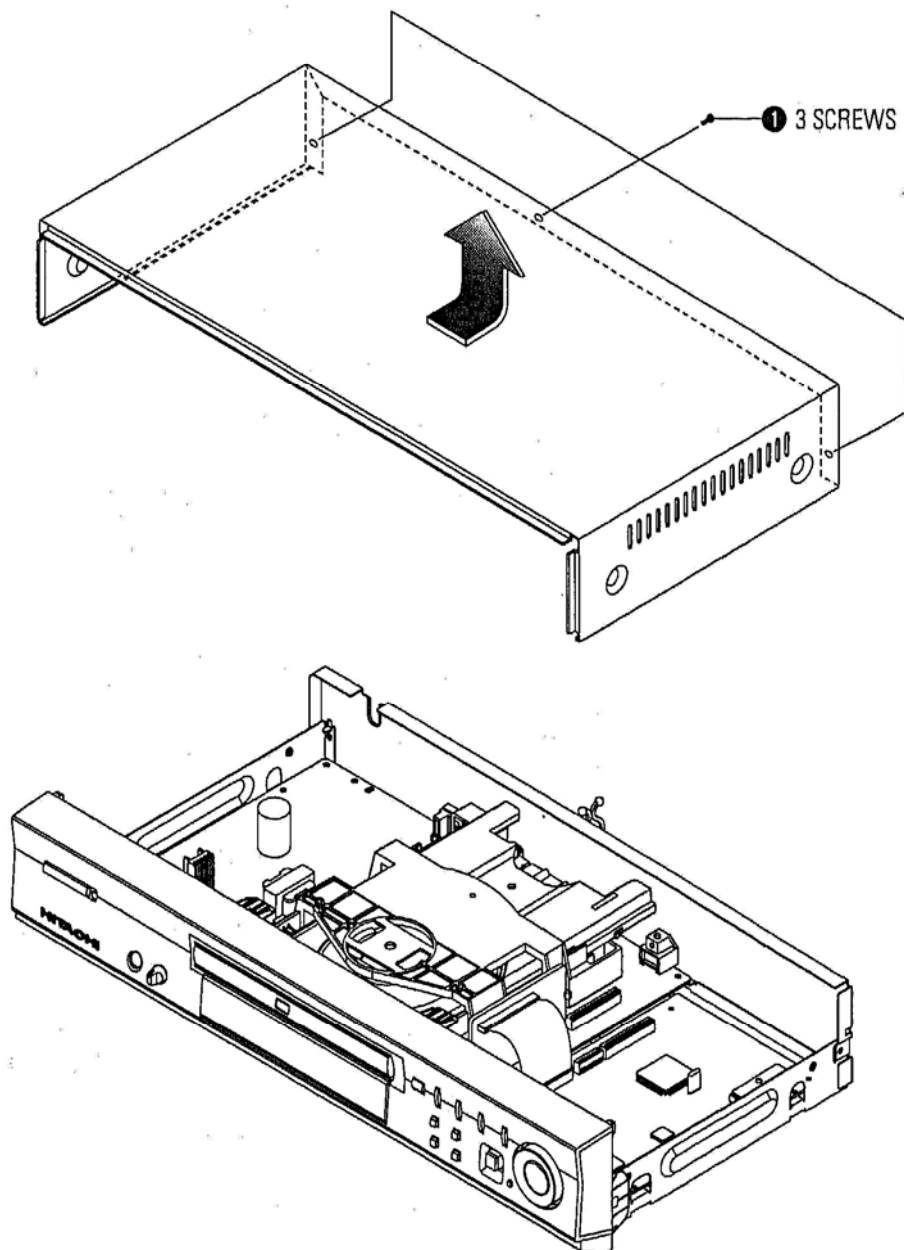

Fig. 4-1 Top Cabinet Removal

4-1-2 Door-Tray Removal

- 1) Supply power and open Tray ❶.
- 2) Disassemble the Door-Tray ❷ in direction of arrow "A".
- 3) Close Tray ❶ and power off.

Note : If Tray ❶ doesn't open, insert a Screw driver ❹ into the Emergency hole ❸ (as shown in detailed drawing) and then push it in the direction of arrow "B". Open Tray manually.

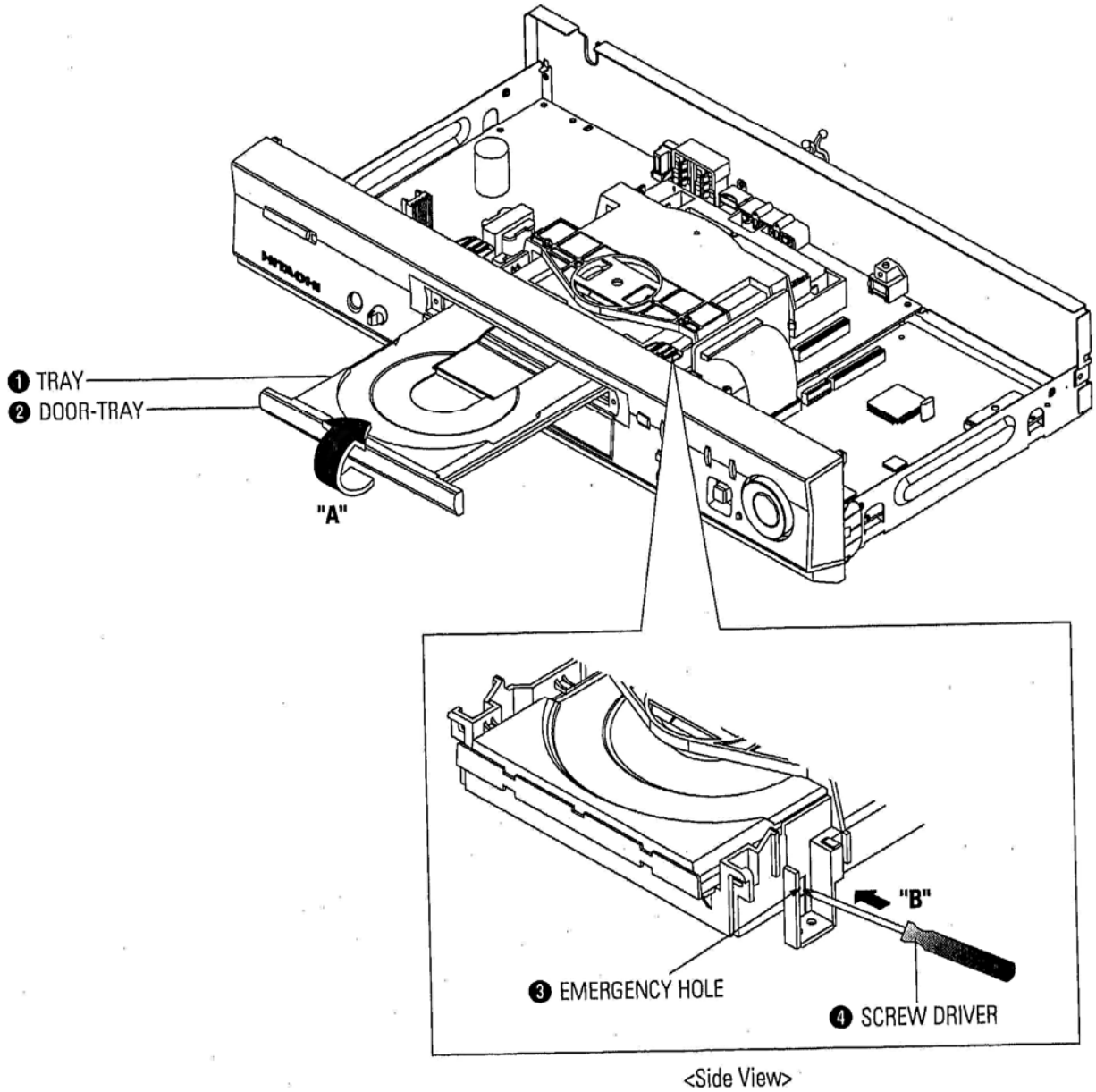

Fig. 4-2 Door-Tray Removal

4-1-3 Ass'y Front-Cabinet Removal

- 1) Remove Knob-Volume ① and Ass'y Front-Cabinet ②.
- 2) Remove Knob-Shuttle ③ and 6 Screws ④ and Key PCB ⑤.

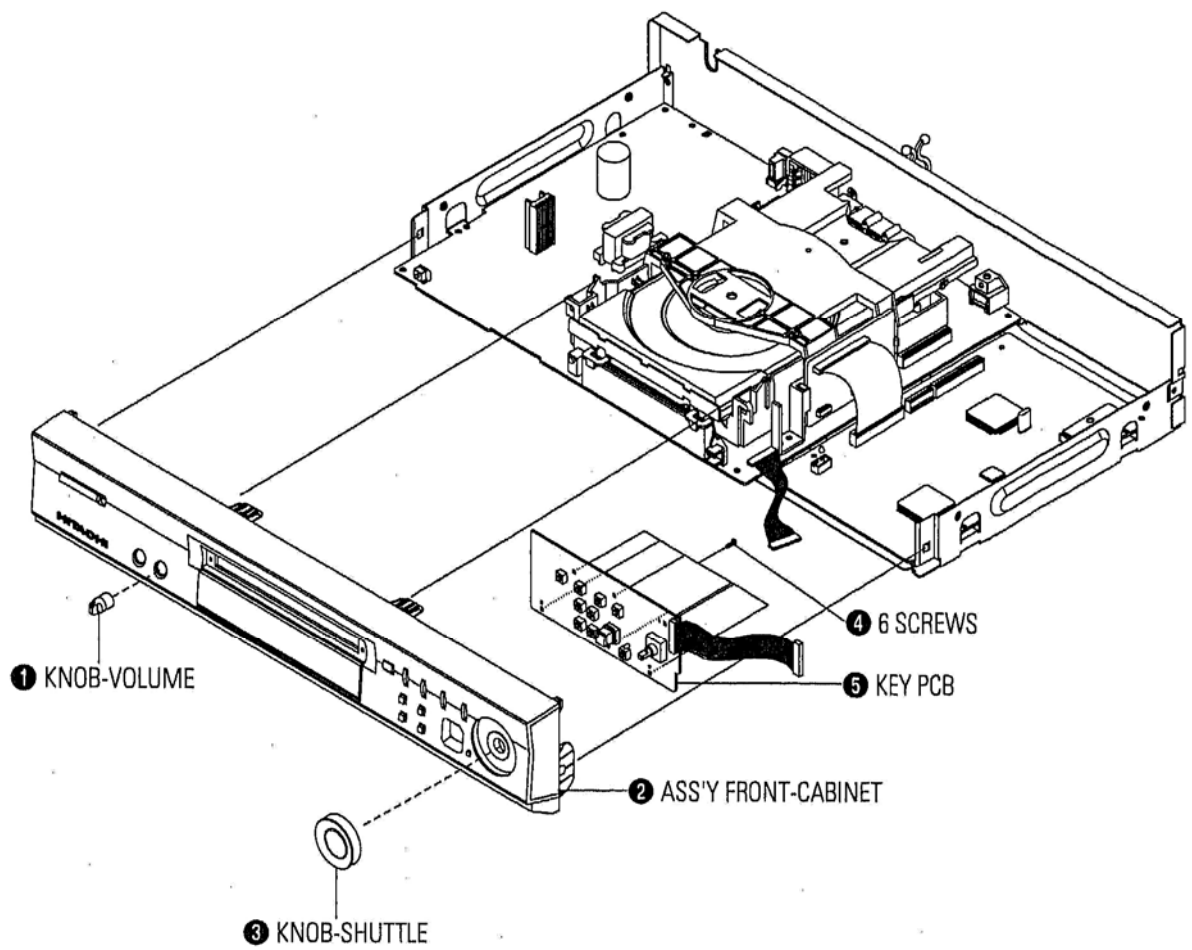

Fig. 4-3 Ass'y Front-Cabinet Removal

4-1-4 Ass'y Deck Removal

- 1) Disconnect Flat-Cable, Connect-Wire from DCN1, DCN2 on Main PCB.
- 2) Remove 3 Screws ❶ from the Ass'y Deck and lift it up.

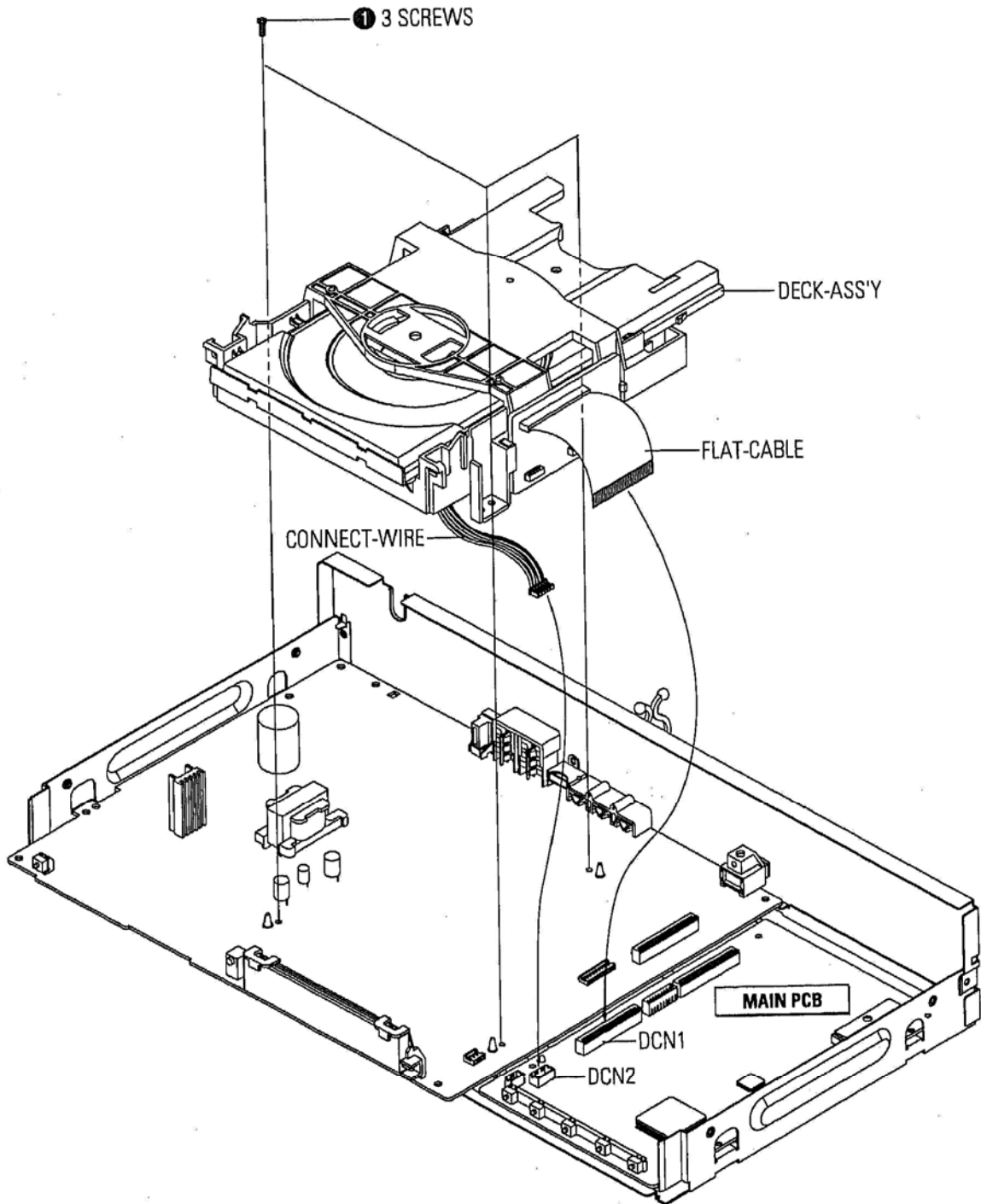

Fig. 4-4 Ass'y Deck Removal

4-1-5 Main PCB, Jack PCB Removal

- 1) Remove 2 Screws ❶ and lift up the Jack PCB ❷.
- 2) Remove 3 Screws ❸ and lift up the Main PCB ❹.

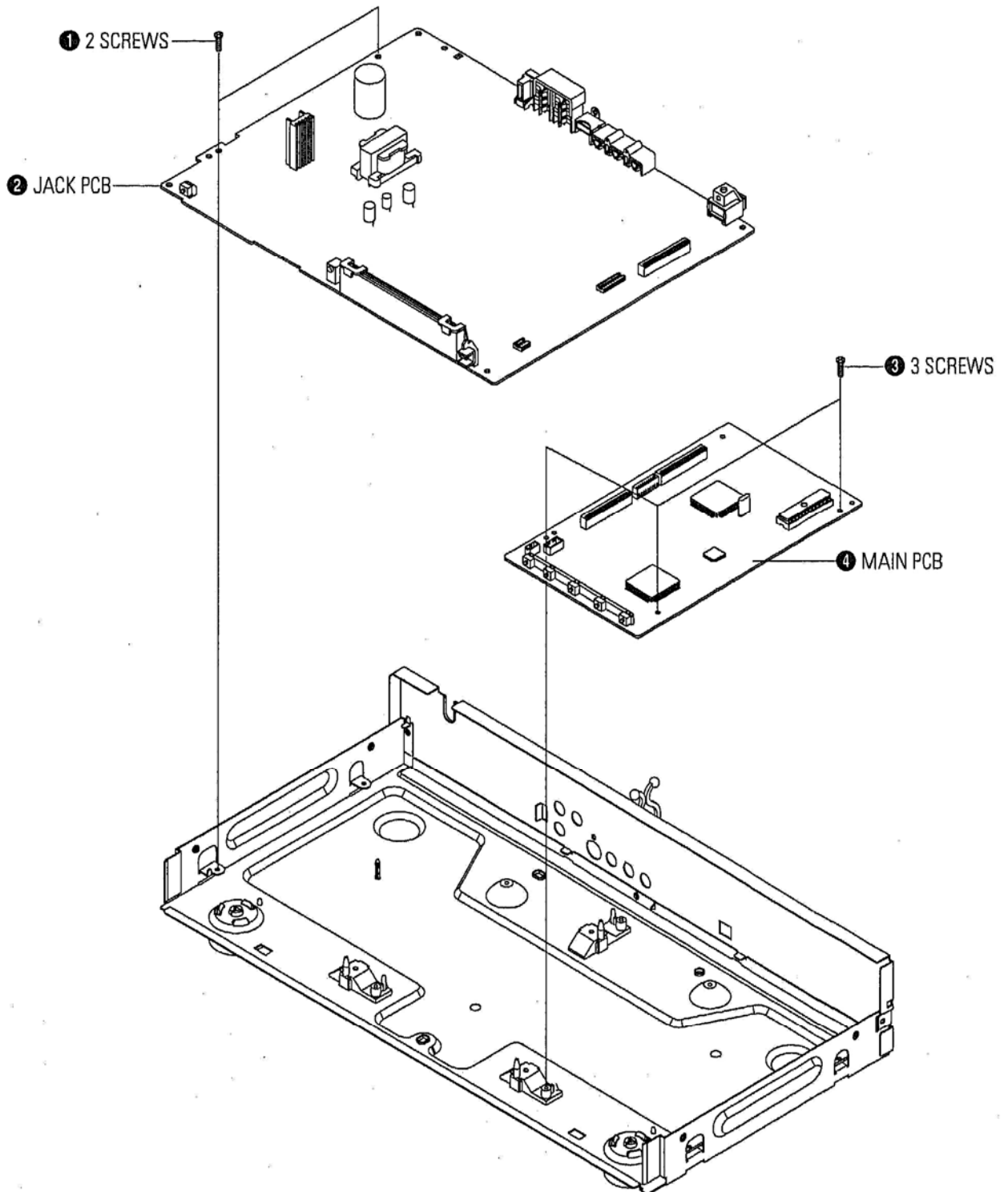

Fig. 4-5 Main PCB, Jack PCB Removal

4-2 PCB Location

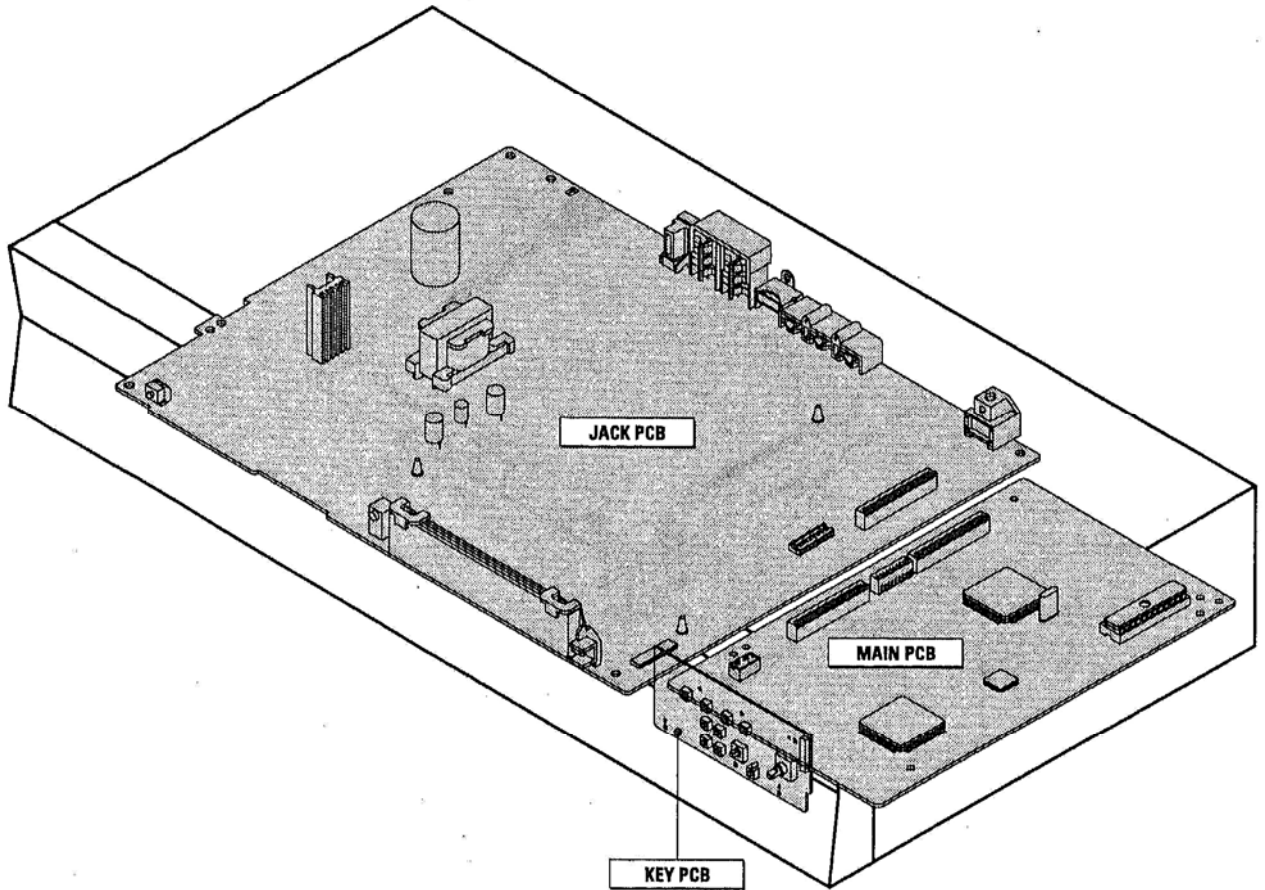
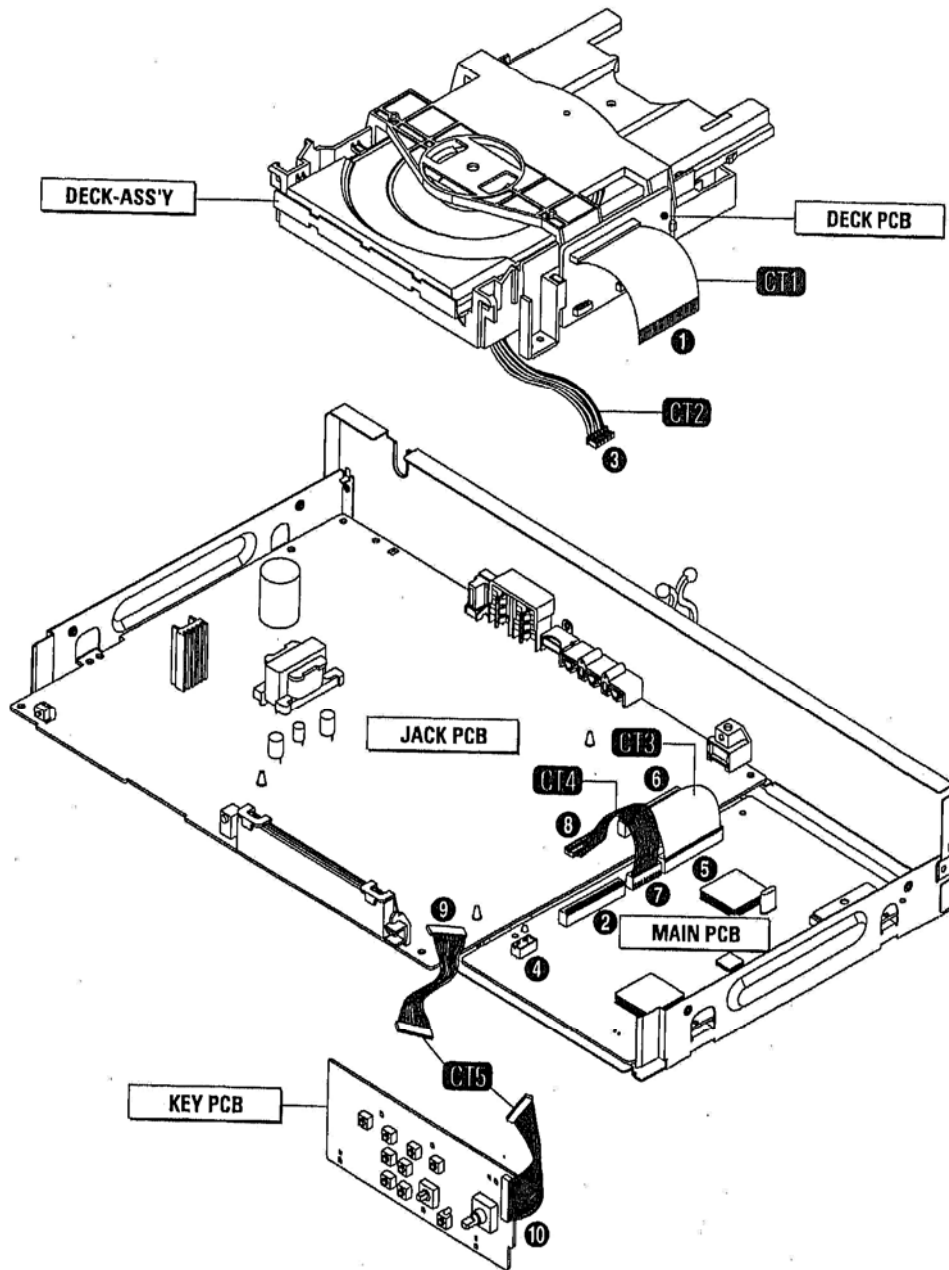

Fig. 4-6 PCB Location

4-3 Connector Diagram



NO.	CONNECTOR NO.	DIRECTION	CONNECTOR NO.	NO.
①	FLAT-CABLE	DECK PCB ← CT1 → MAIN PCB	DCN1	②
③	CONNECT-WIRE (HCN1)	HOUSING PCB ← CT2 → MAIN PCB	DCN2	④
⑤	CN8	MAIN PCB ← CT3 → JACK PCB	CN1	⑥
⑦	PCN1	MAIN PCB ← CT4 → JACK PCB	PCNS1	⑧
⑨	CN3	JACK PCB ← CT5 → KEY PCB	KCN1	⑩

Fig. 4-7 Connector Diagram

4-4 Deck

4-4-1 Tray Disc Removal

- 1) Insert a Screw Driver ① into Emergency Hole ② and push the Slider Housing ③ in the direction arrow "A".
- 2) When the Tray Disc ④ comes out a little, pull it in the direction arrow "B" by hand.
- 3) Pull the Tray Disc ④ to disassemble, while simultaneously pushing 2 Stoppers ⑤ (left, right) in the direction arrow "C", "D".

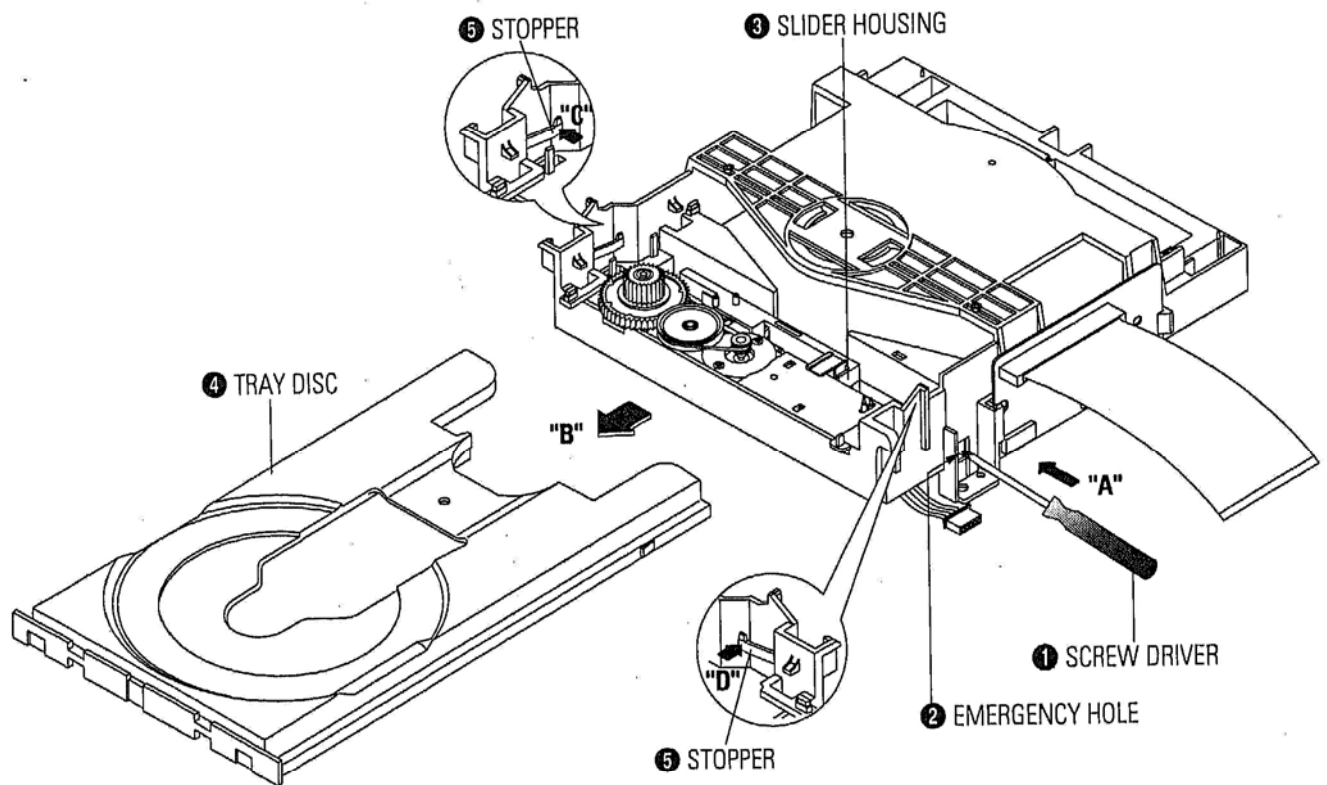

Fig. 4-8 Tray Disc Removal

4-4-2 Ass'y P/U Deck Removal

- 1) Disconnect DCN2 ①, DCN3 ②.
- 2) Lift down the Ass'y P/U Deck ③ while simultaneously pushing 2 Hooks ④, ⑤ in the direction of arrow "A", "B".

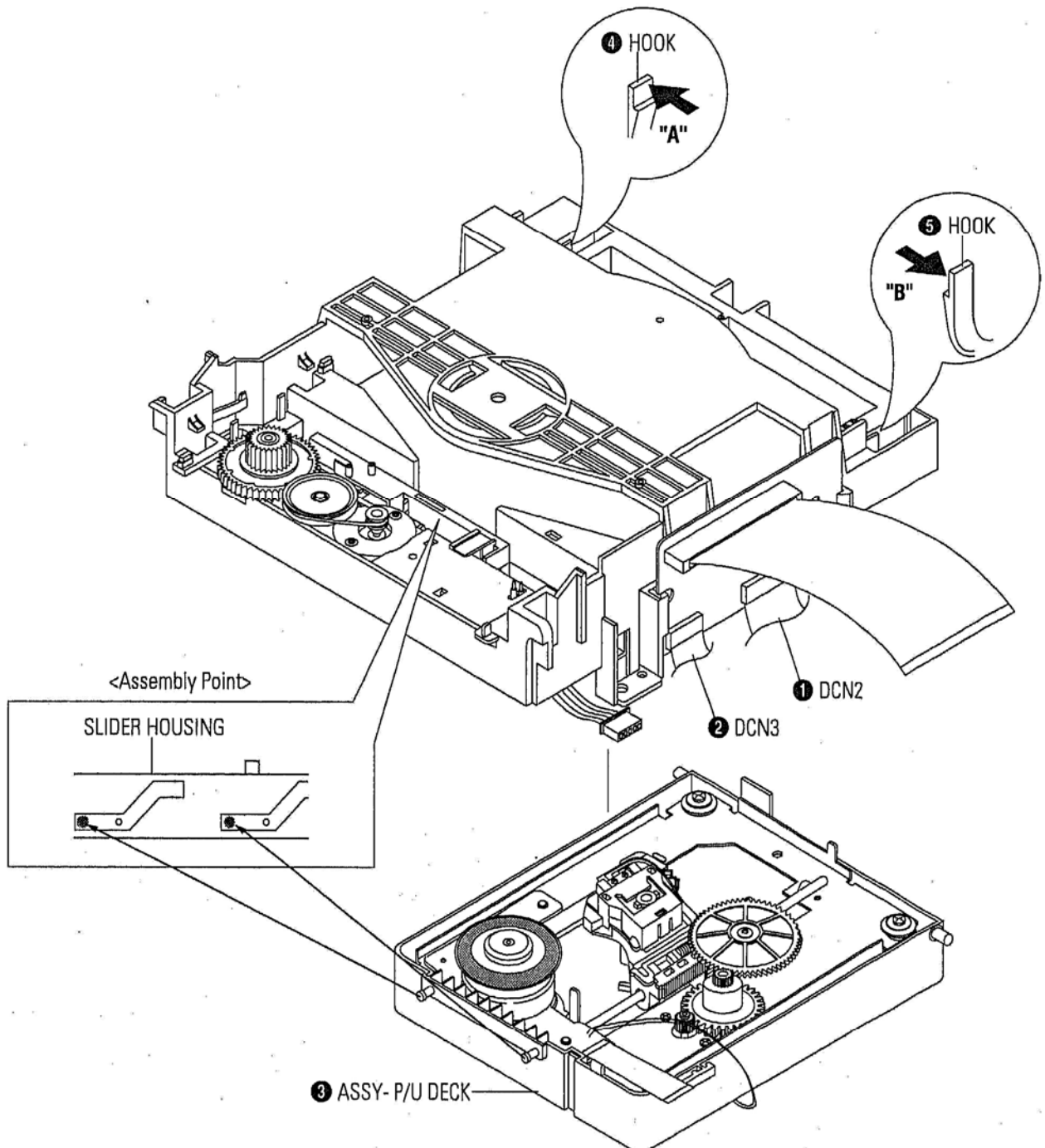

Fig. 4-9 Ass'y P/U Deck Removal

4-4-3 Housing Ass'y Removal

- 1) Remove Belt ①.
- 2) Push the Hook ② in the direction arrow "A" and lift up Pulley Gear ③.
- 3) Push the Slider Housing ⑤ in the direction arrow "B" and lift up the Gear Tray ④.
- 4) Lift up the Slider Housing ⑤.
- 5) Remove the soldering ⑥ of 2 points (Red, Black).
- 6) Remove 2 Screws ⑦ and lift down the Motor Load Ass'y ⑧.
- 7) Push the 3 Hooks ⑨ bottom side in the direction arrow "C" and lift up the Housing PCB ⑩.
- 8) Push the Hooks ⑪ and remove Deck PCB ⑫.

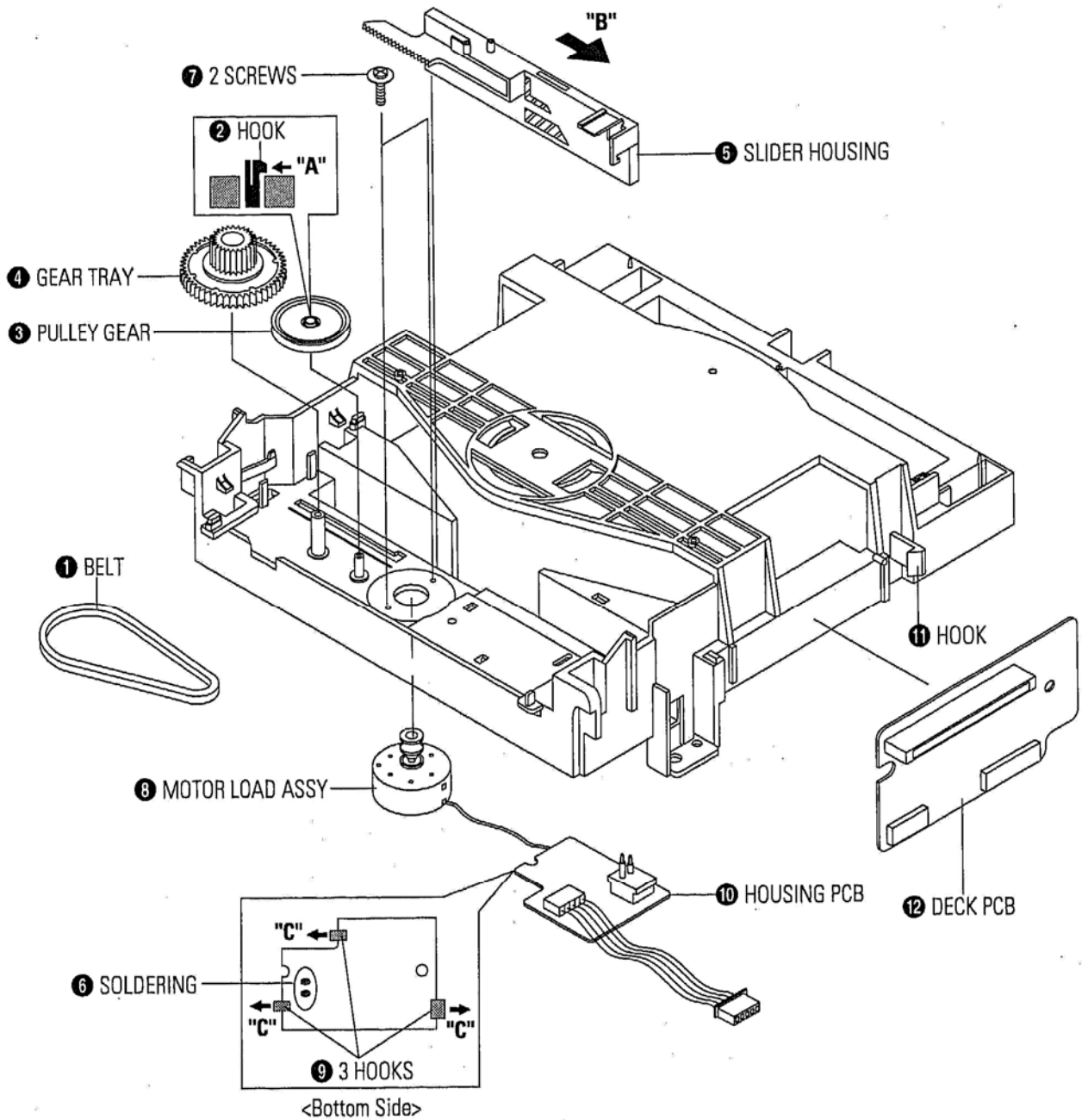

Fig. 4-10 Housing Ass'y Removal

4-4-4 Sub Chassis Removal

- 1) Remove the Soldering of Motor Feed (+, - wire) ❶.
- 2) Remove the 4 Screws ❷.
- 3) Lift up the Ass'y Brkt Deck ❸.

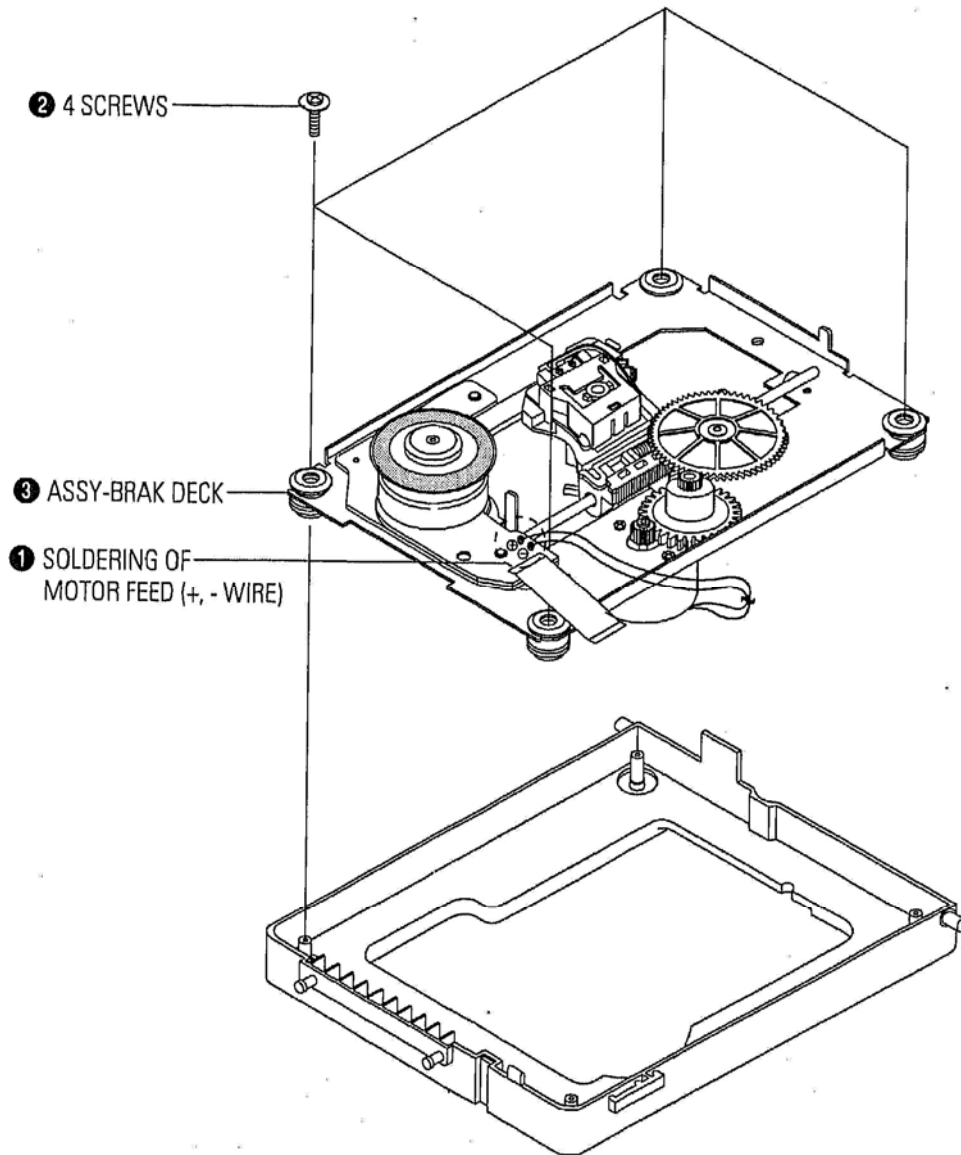

Fig. 4-11 Sub Chassis Removal

4-4-5 Ass'y Brkt Deck Removal

- 1) Remove Washer ①.
- 2) Remove Gear Feed B ② , Gear Feed A ③.
- 3) Remove 2 Screws ④.
- 4) Remove Shaft Pick-Up ⑤ and Pick-Up Ass'y ⑥.
- 5) Remove 1 Screw ⑦.
- 6) Remove 2 Screws ⑧.
- 7) Remove 3 Spring Spindle ⑨ and Motor Spindle Ass'y ⑩.

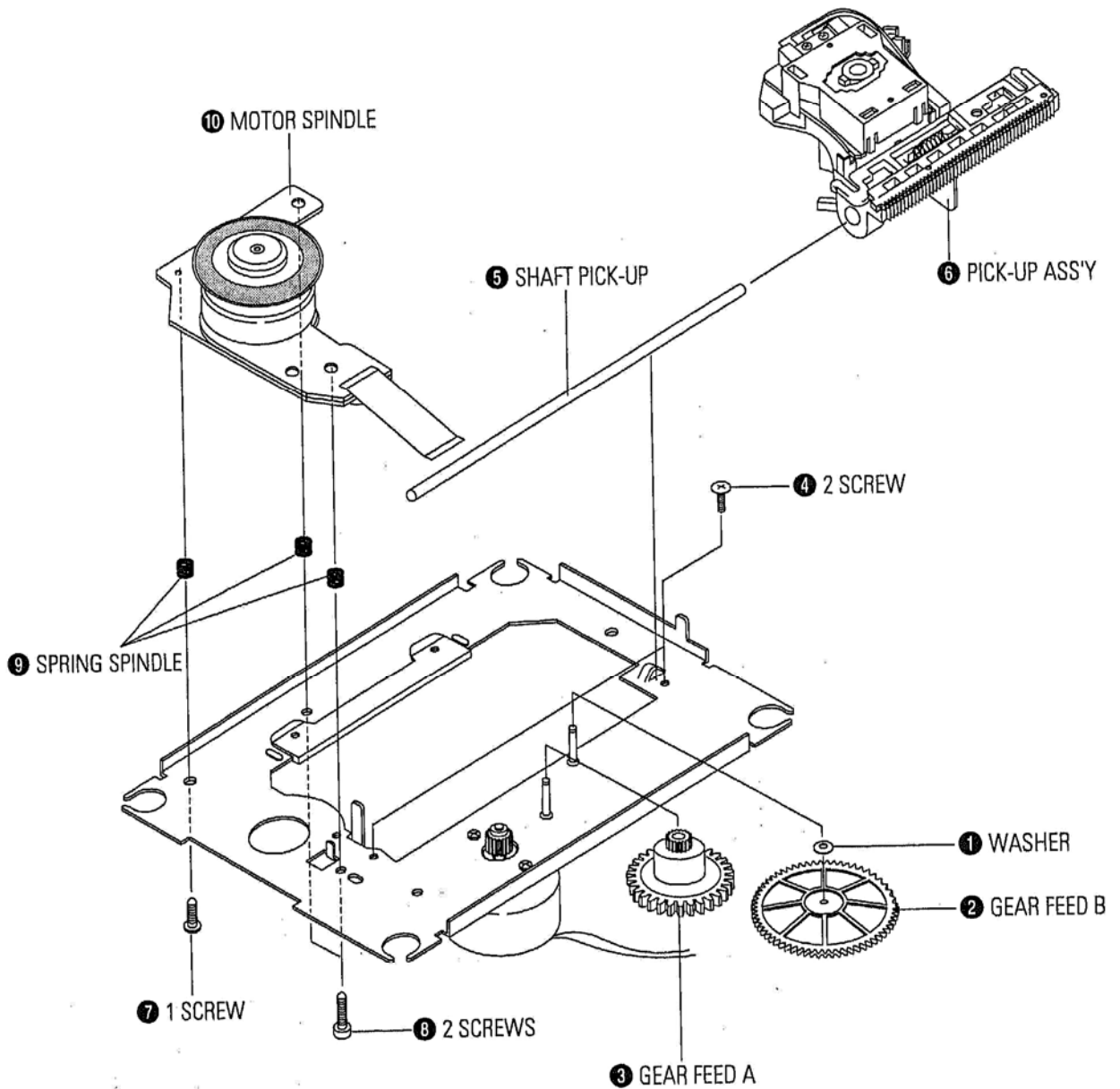
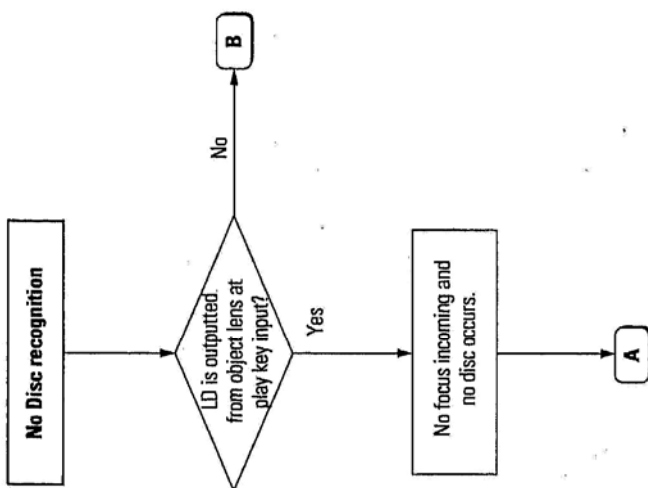
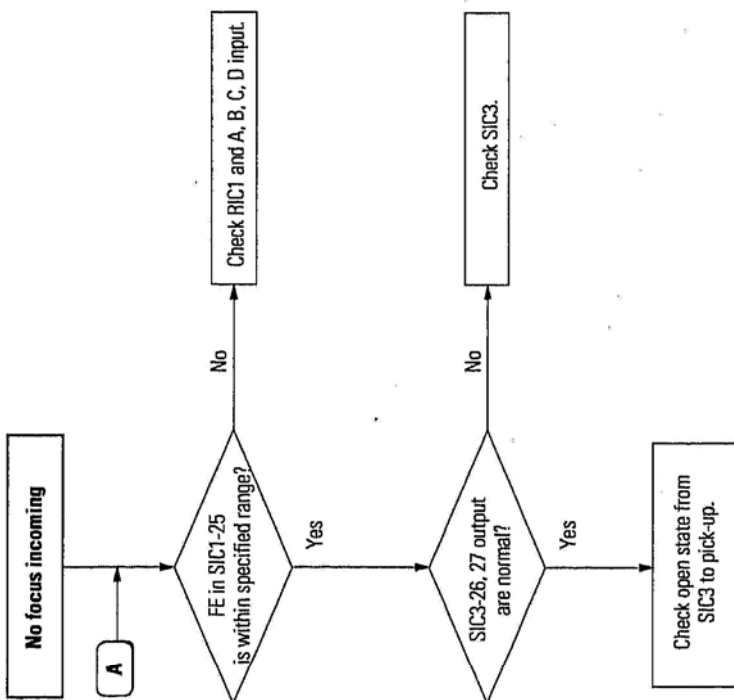
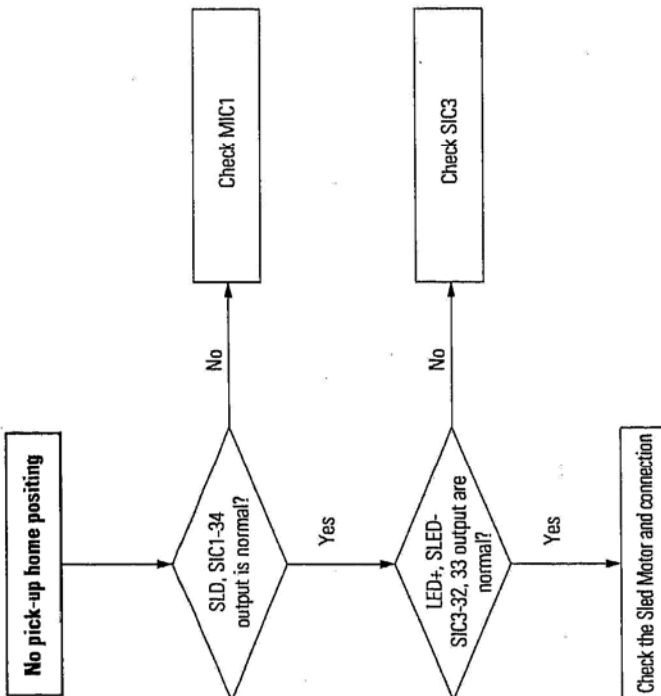
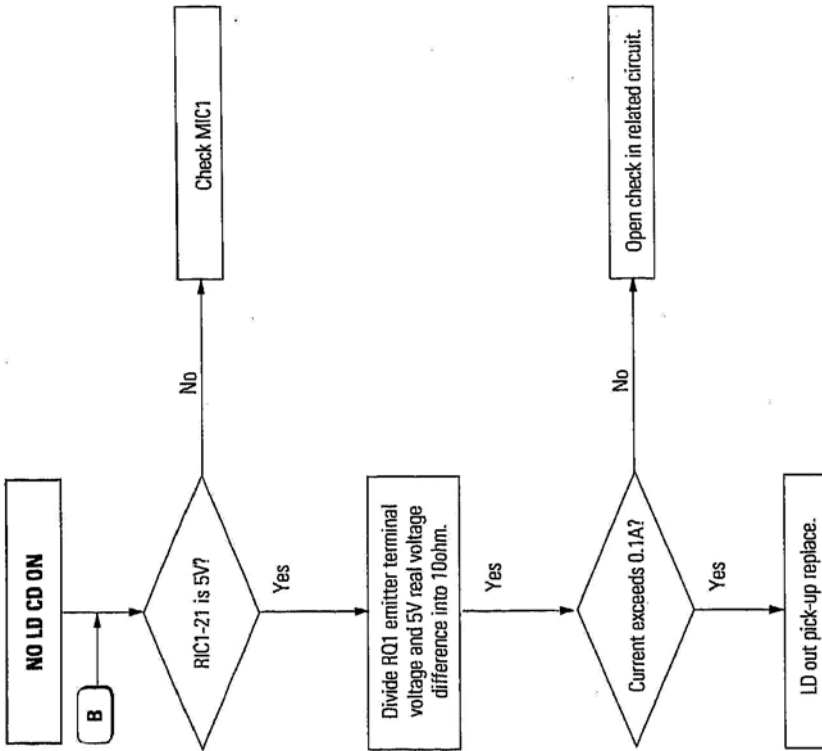
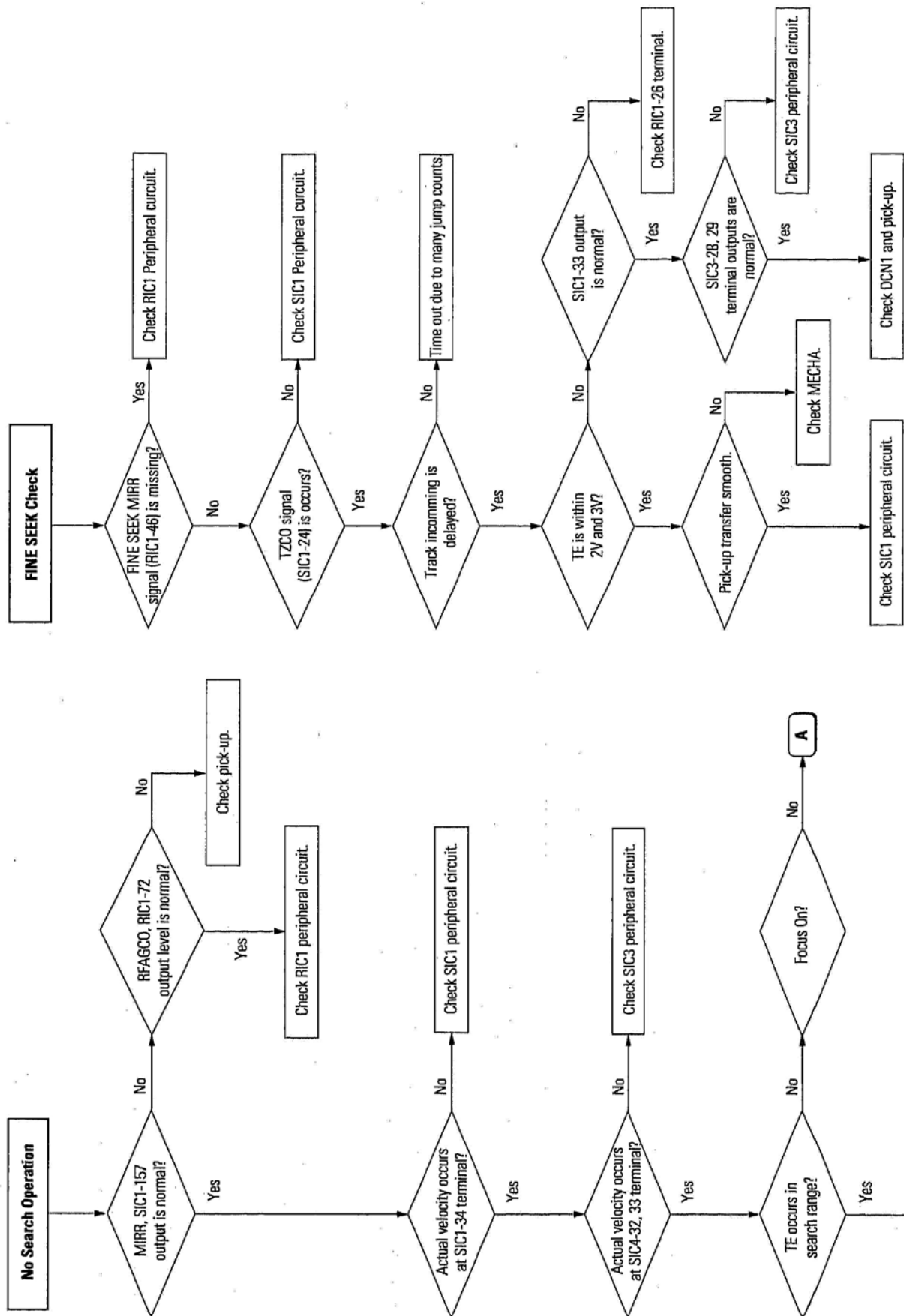

Fig. 4-12 Ass'y Brkt Deck Removal

5. Troubleshooting







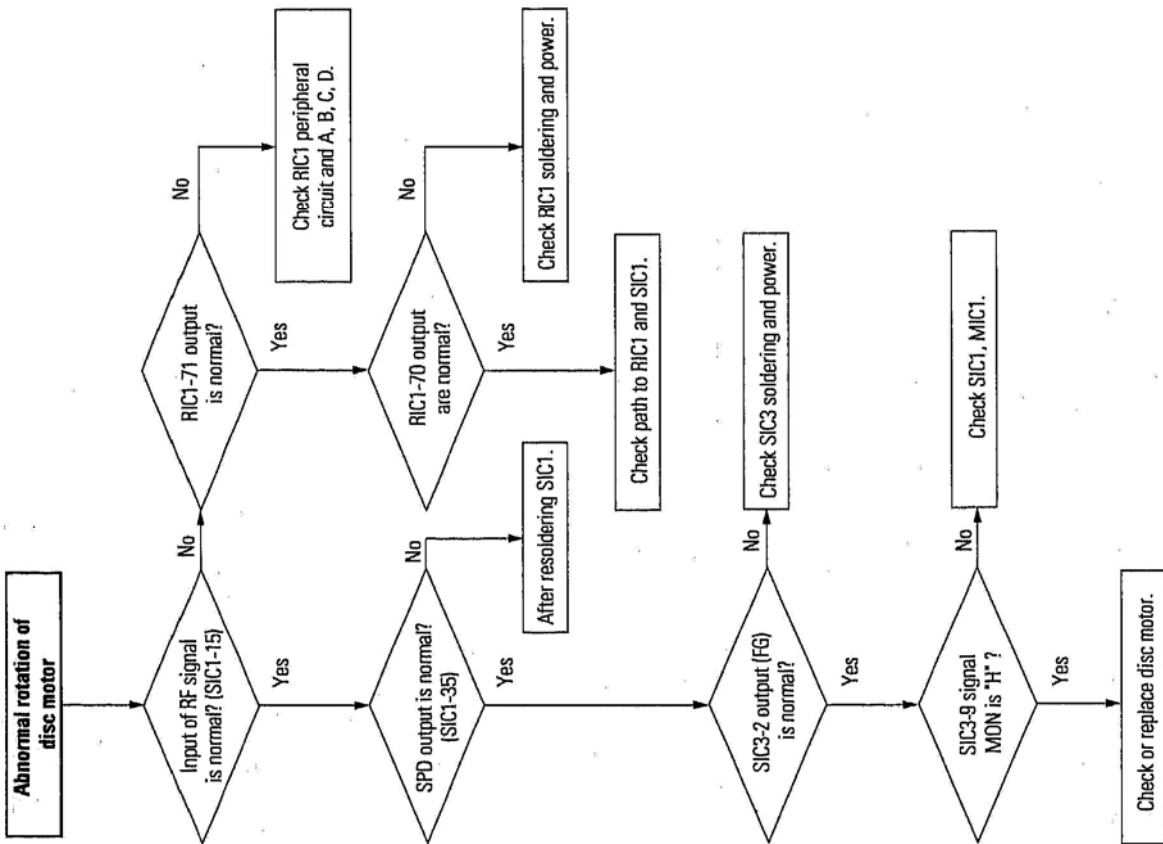
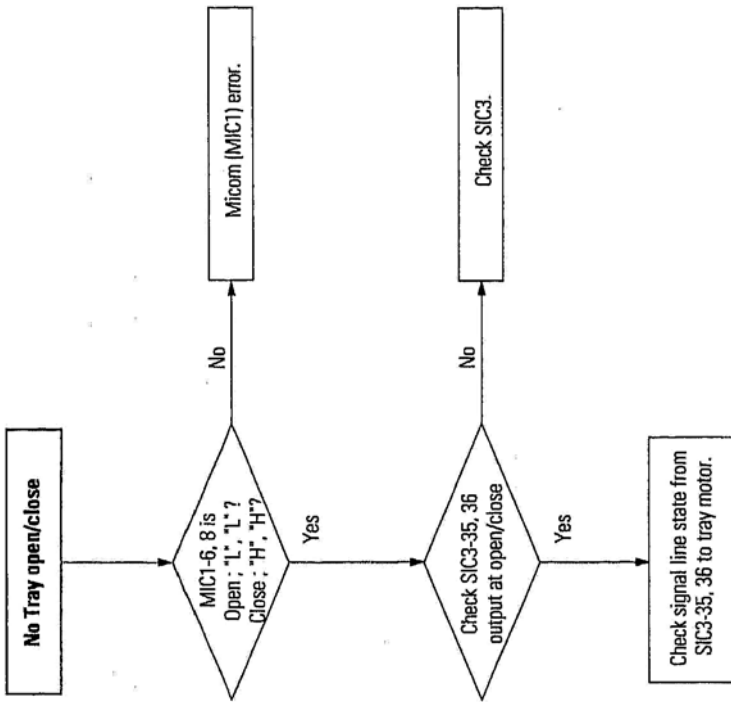

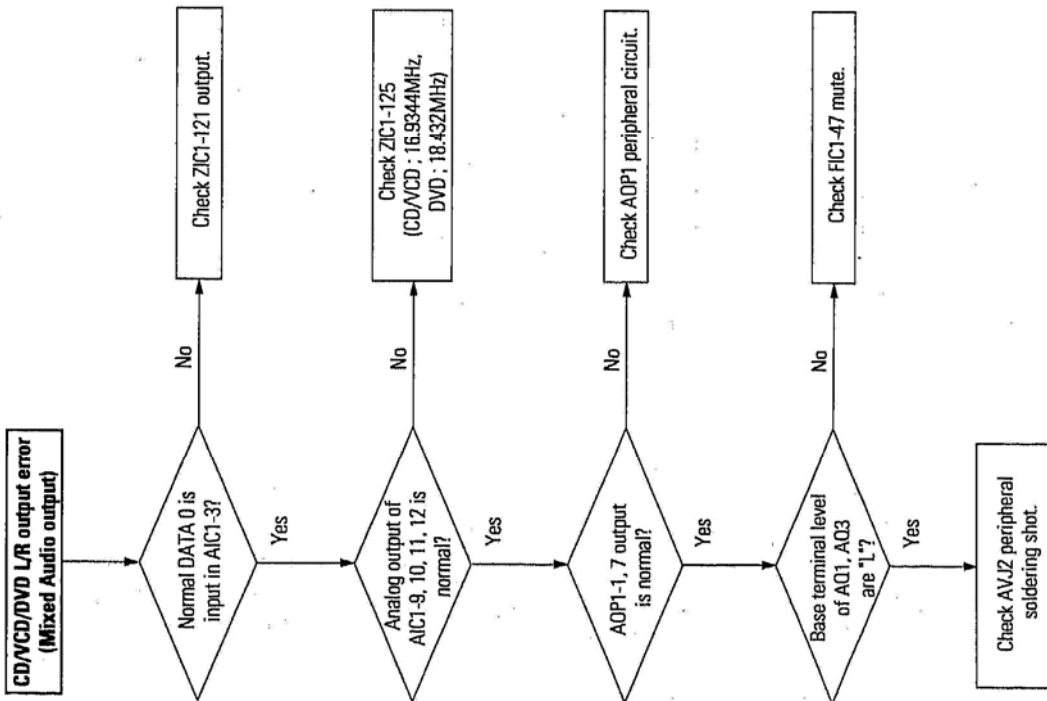
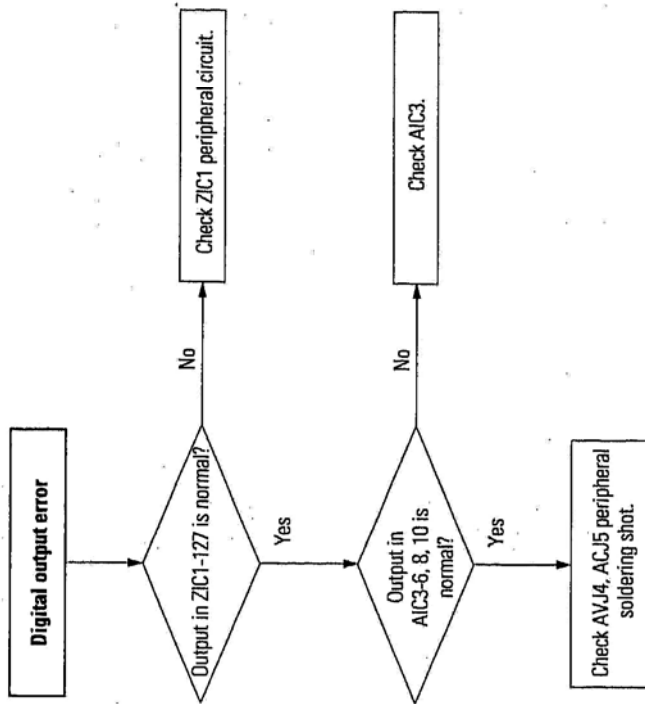

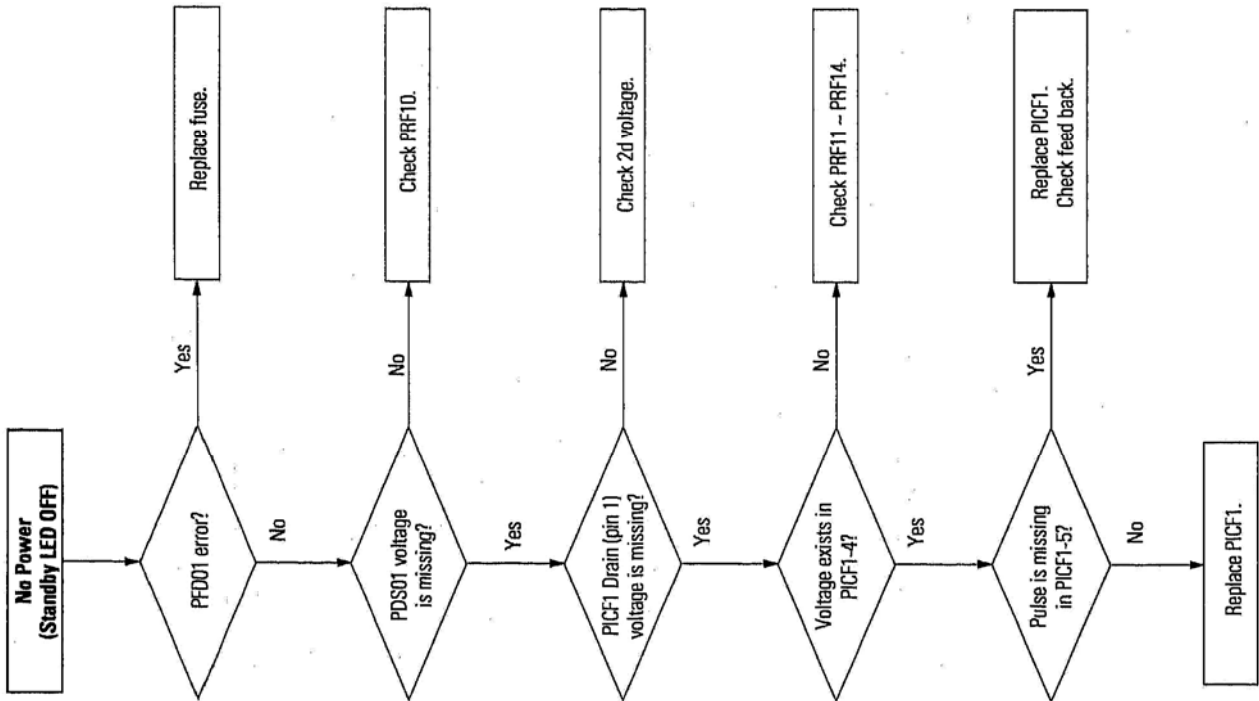
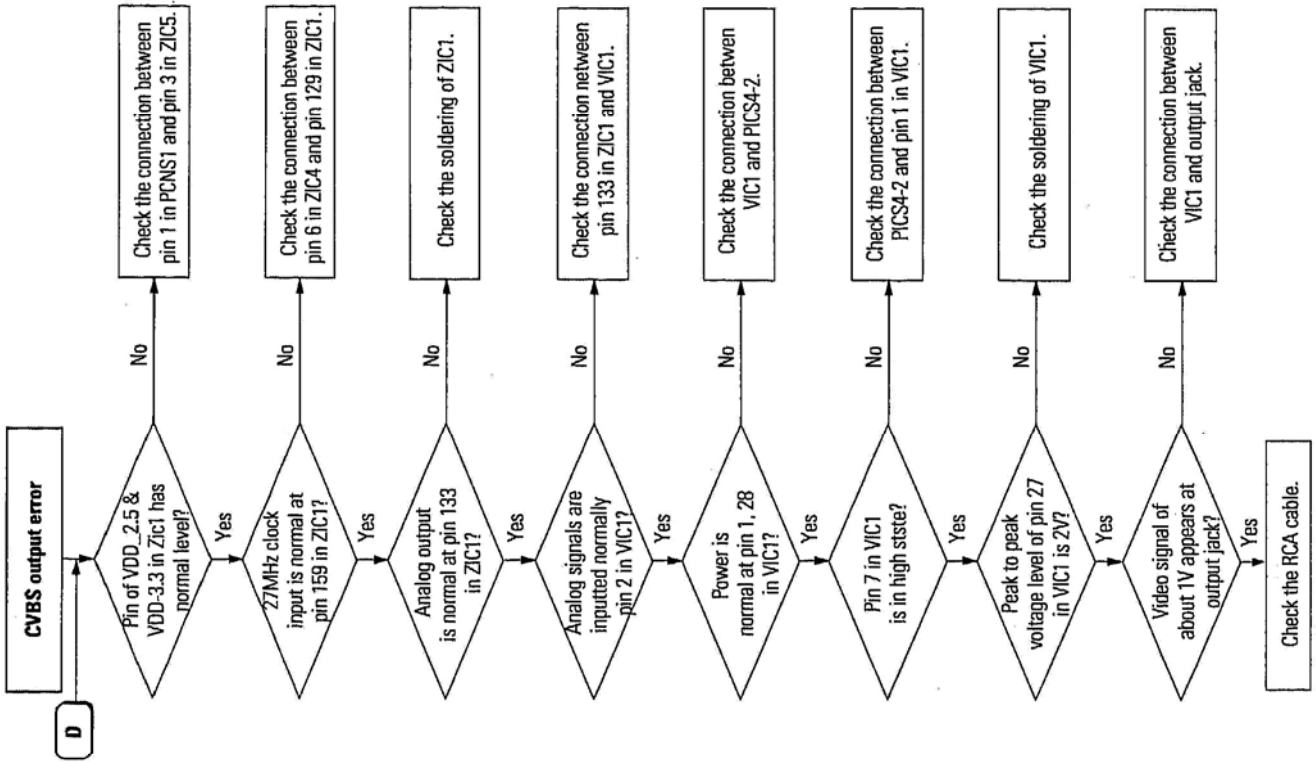

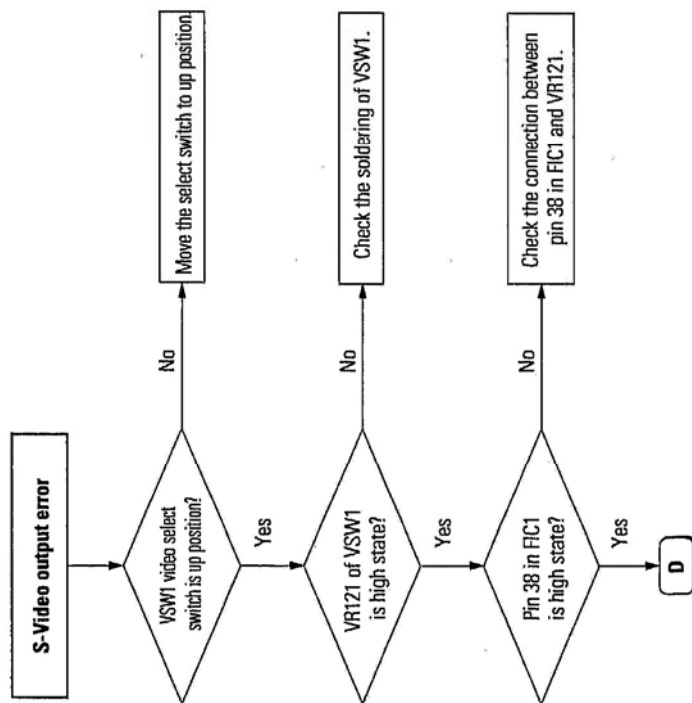
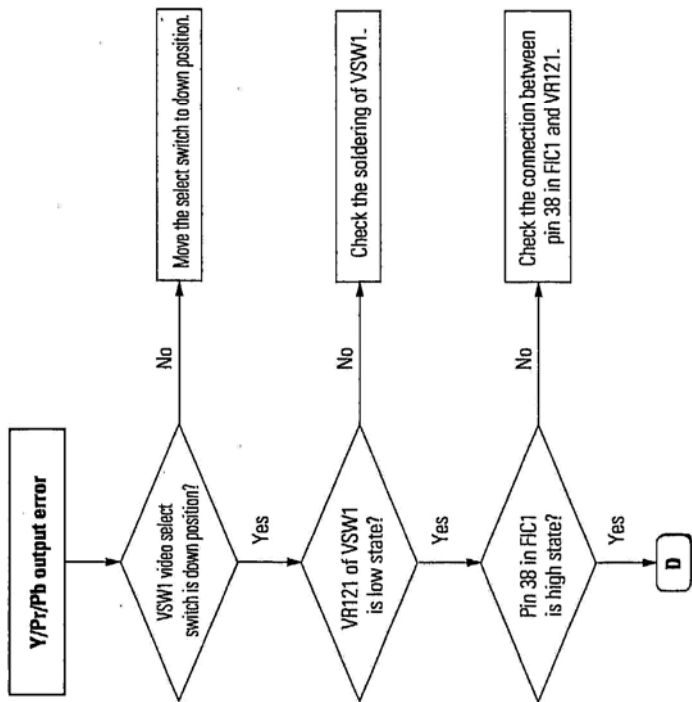

MEMO

6. Exploded View

6-1 Cabinet Assembly

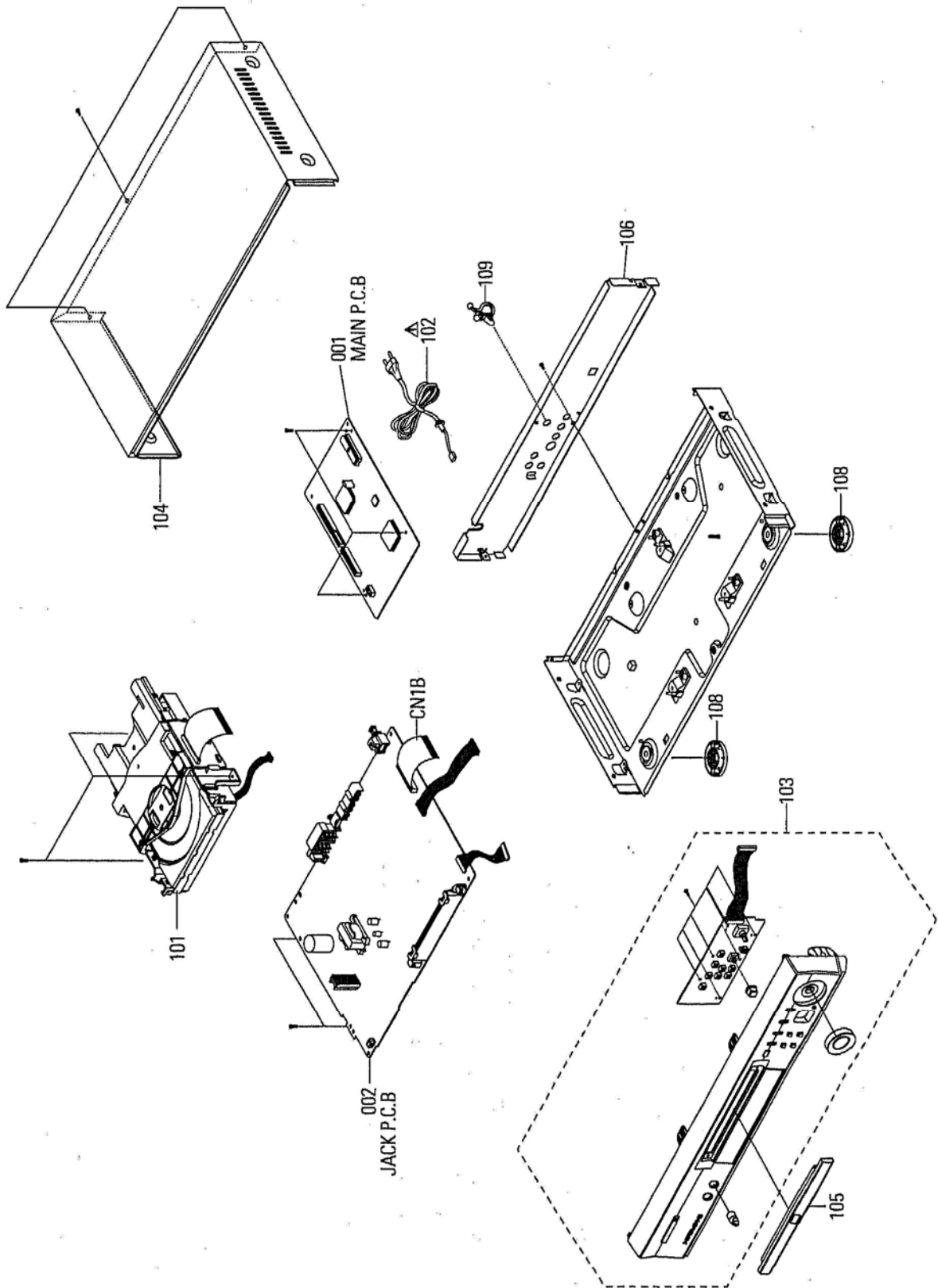

6-2 Deck Assembly

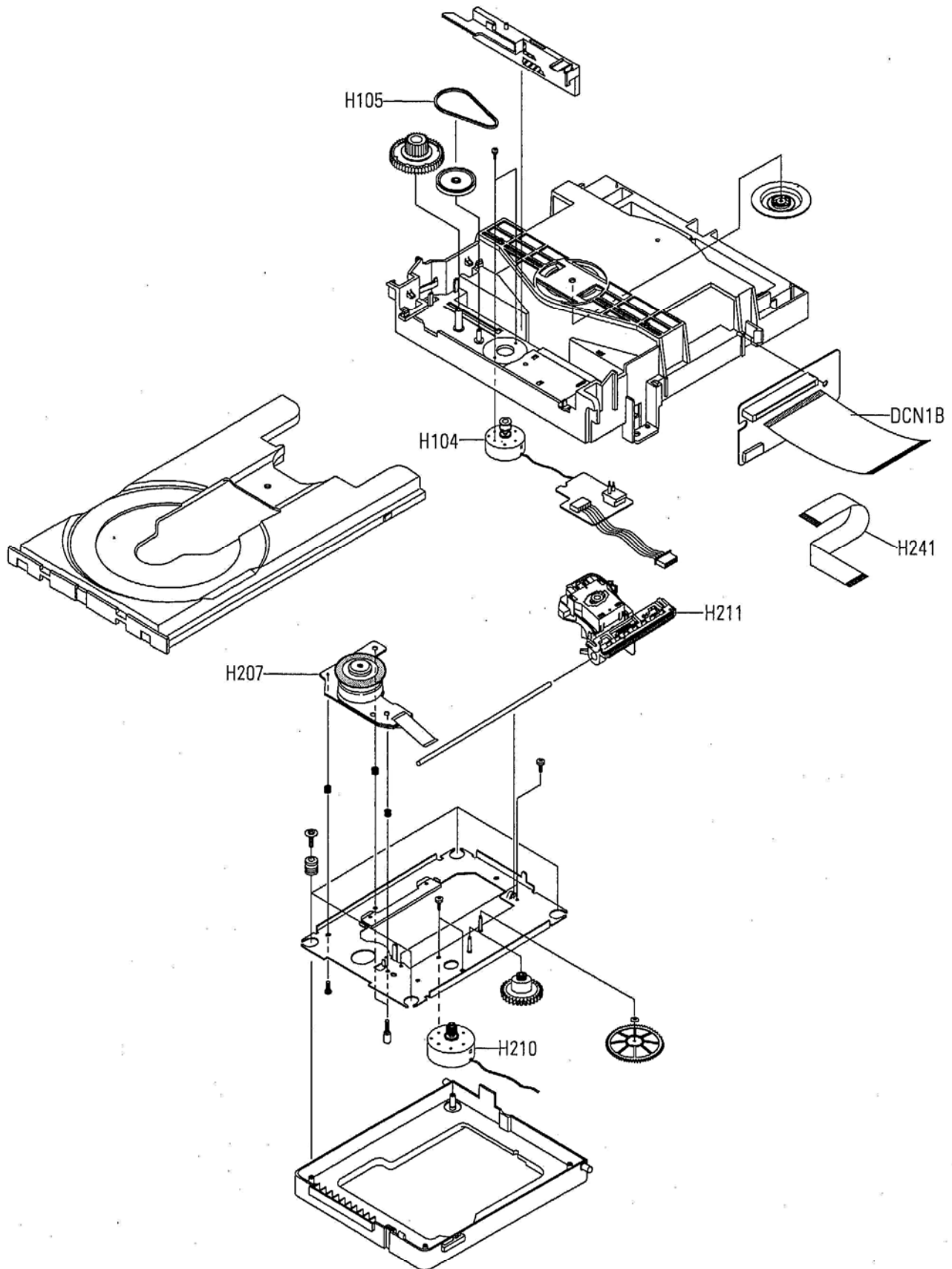

7. Replacement Parts List

7-1. Mechanical Parts List

SYMBOL NO	P-NO	DESCRIPTION
MECHANISM SECTION		
101	TS16461	MECHA ASSY(DVD)
△ 102	TE13511	CORD, POWER
103	TJ15261	PANEL, FRONT
104	TJ15002	COVER, TOP
105	TJ15091	DOOR ASSY
106	TJ15381	PANEL, REAR
108	TJ15041	FOOT, FRONT
109	TJ15051	HOLDER, CORD
H104	TS16341	MOTOR, LOAD
H105	TJ15031	BELT, PUULEY
H207	TS16351	MOTOR, SPINDLE
H210	TS16361	MOTOR, FEED
H211	TS16491	PICK UP ASSY
H241	TE14011	CONNECTOR
001	TS16651	PWB ASSY MAIN
002	TS16661	PWB ASSY JACK

ACCESSARIES

802	TS16331	REMOTE HAND SET
803	TE13361	CABLE, AV

7-2. Electrical Parts List

SYMBOL NO	P-NO	DESCRIPTION
△ PCD01	TA14391	CERAMIC DISC 100nF
△ PCD02	TA14401	CERAMIC DISC 2.2nF
△ PCD03	TA14401	CERAMIC DISC 2.2nF
△ PCF01	TA14391	CERAMIC DISC 100nF
△ PCF02	TA14391	CERAMIC DISC 100nF
△ PCS03	TA14391	CERAMIC DISC 100nF
△ PEF10	TA14381	CAPACITOR 82UF 400V
△ PDS01	TC11631	DIODE 1T5
△ PDS02	TC11631	DIODE 1T5
△ PDS03	TC11631	DIODE 1T5
△ PDS04	TC11631	DIODE 1T5
PDS11	TC11661	DIODE UF4007
AIC1	TC11751	IC AK4382VT
AIC2	TC12141	IC AK4356
AIC3	TC11481	IC M74HCU04
AOP1	TC11511	IC BA4560
AOP2	TC11511	IC BA4560
AOP3	TC11511	IC BA4560
AOP4	TC11511	IC BA4560
FIC1	TC11921	IC UPD780232GC-033-8BT
FIC2	TC11541	IC KA7545
FIC4	TC11791	MODULE, REMOCON
HOP1	TC11511	IC BA4560
HOP2	TC11511	IC BA4560
MIC1	TC11931	IC TMP91C219F
MIC2	TC12091	IC M27C801-120F1
MIC3	TC11941	IC T15M256A
MIC4	TC11681	IC 24C021
MIC5	TC11351	IC TC7S08F
MIC6	TC11691	IC TC7S32F
MIC7	TC11401	IC TC7SET00F
PIC1	TC11701	IC MM1365
△ PICF1	TC12131	IC STRG6351
△ PICS1	TC11591	PHOTO COUPLER PC123
PICS2	TC11581	IC KA431Z
PICS3	TC11551	IC KA7908
PICS4	TC11561	IC KA78R08
PICS5	TC12111	IC PQ3RD13
△ PICS6	TE13911	IC PROTECTOR ICP-N25
△ PICS7	TE13911	IC PROTECTOR ICP-N25
RIC1	TC11712	IC S5L1462B
SIC1	TC11721	IC S5L1454A
SIC2	TC11731	IC MM11B416256A
SIC3	TC11441	IC KA3017
SIC4	TC11351	IC TC7S08F
VIC1	TC11771	IC MM1540
ZIC1	TC11461	IC ZIVA4.1
ZIC2	TC12121	IC K4S64163D-TC80
ZIC4	TC11481	IC M74HCU04
△ PRE32	TE13911	IC PROTECTOR ICP-N25

Replacement Parts List

SYMBOL NO	P-NO	DESCRIPTION	SYMBOL NO	P-NO	DESCRIPTION
△ PVA1	TC11641	SOMICONDUCTOR SVC471D			
△ PTD1	TA14461	SWITCHING,TRANS			
FY1	TE13901	RESONATOR 5MHZ			
MY1	TE14351	CRYSTAL			
SY1	TE13881	CRYSTAL 33.8688MHZ			
ZY1	TE13891	CRYSTAL 27HMZ			
AVJ1	TE13931	JACK			
AVJ2	TE14571	JACK			
AVJ3	TE14581	JACK			
AVJ4	TE14191	JACK			
AVJ5	TE14331	CONNECTOR			
SVJ1	TE13951	JACK			
CN1B	TE14001	CONNECTOR			
DCN1B	TE14001	CONNECTOR			
△ PCNS2	TE14291	CONNECTOR			
△ PFD01	TE13401	FUSE			
△ PLF01	TA14361	FILTER,LINE			
△ PLS01	TA14201	FILTER,LINE			
VFD1	TE13921	DISPLAY			
HSW1	TE14021	SWITCH			
VSW1	TE13971	SWITCH,SLIDE			

8. Block Diagram

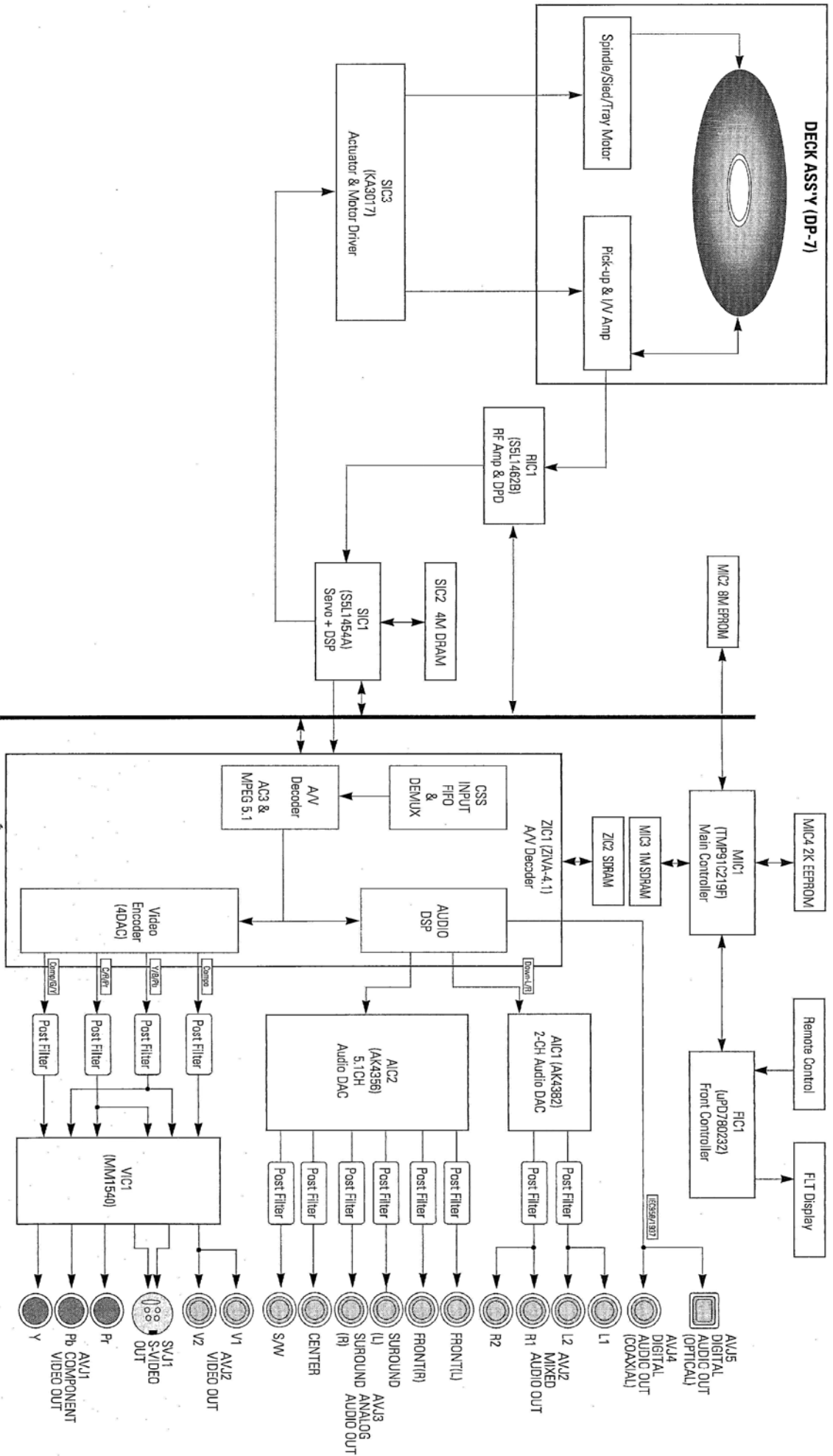

MEMO

9. PCB Diagrams

9-1 Main

COMPONENT

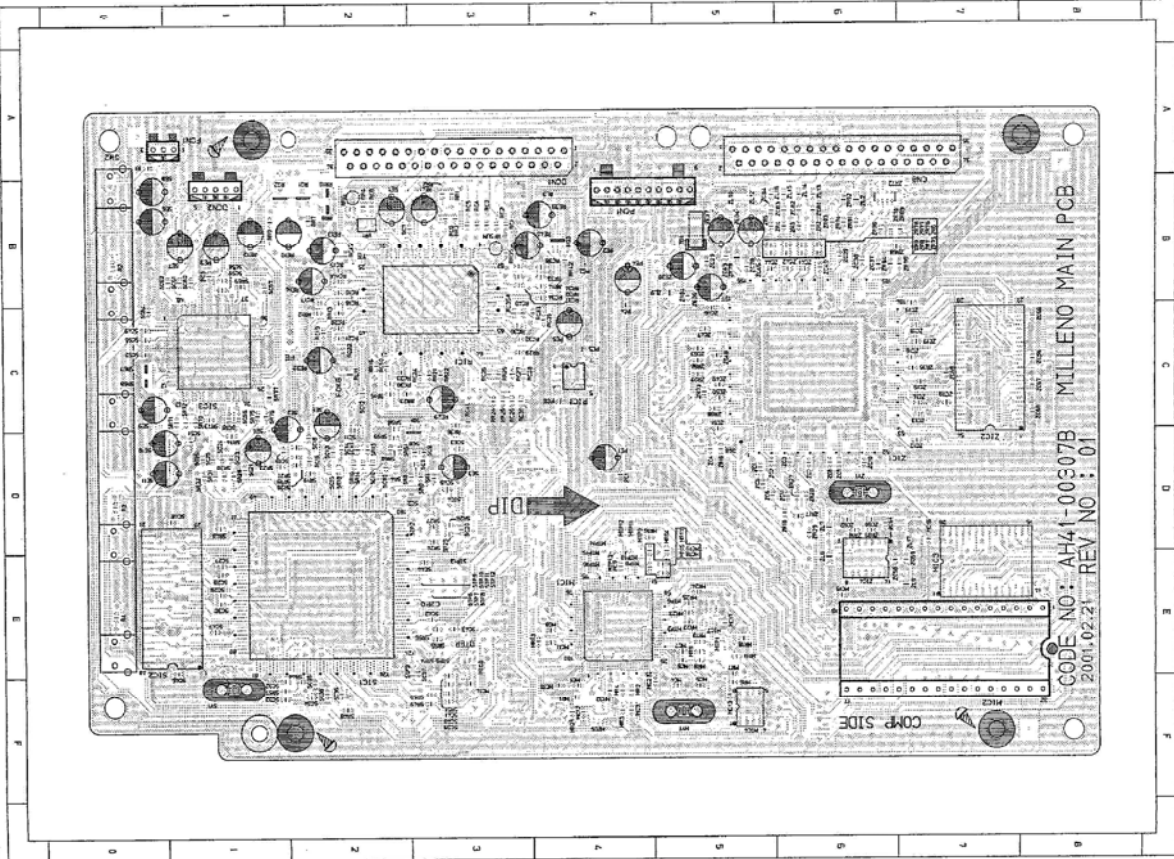

SOLDER SIDE

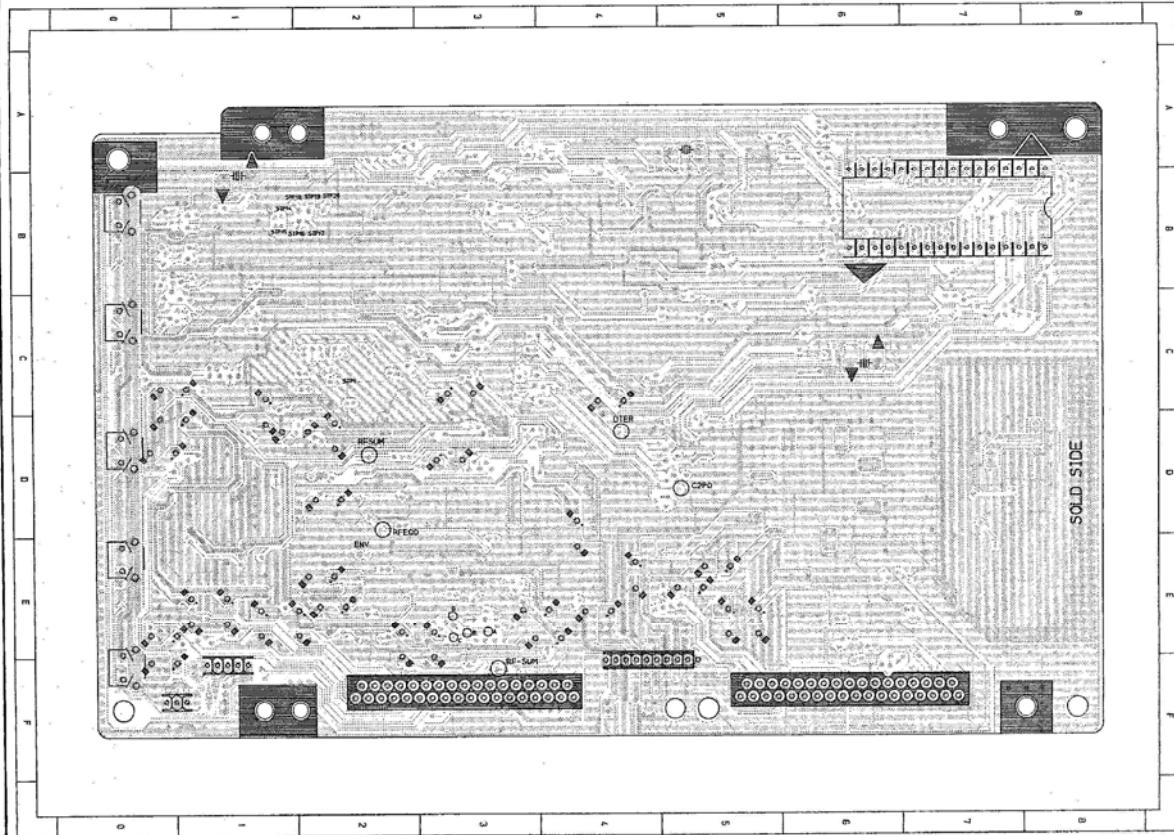

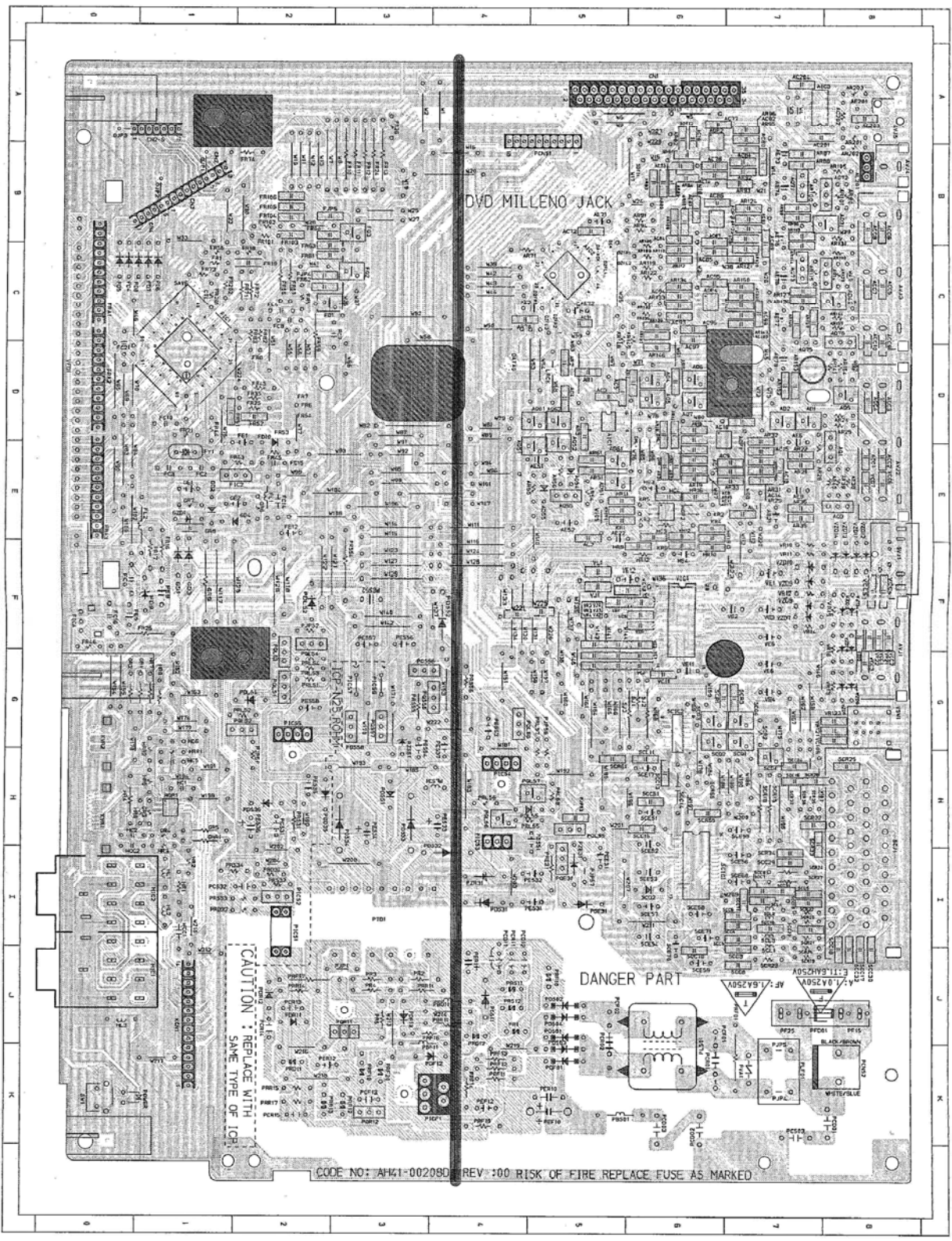

MEMO

10. Wiring Diagram

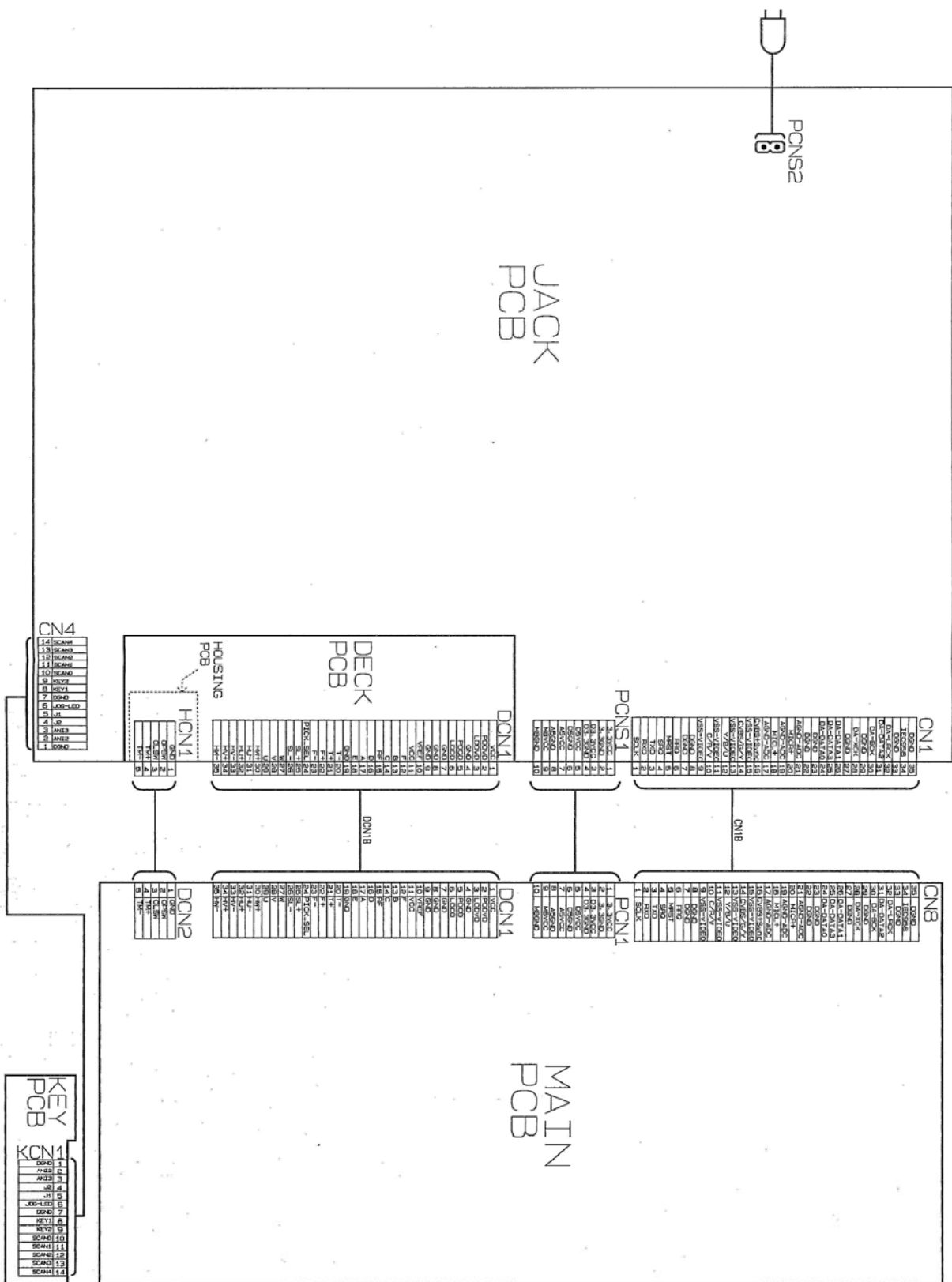

MEMO

11. Schematic Diagrams

Block Identification of PCB

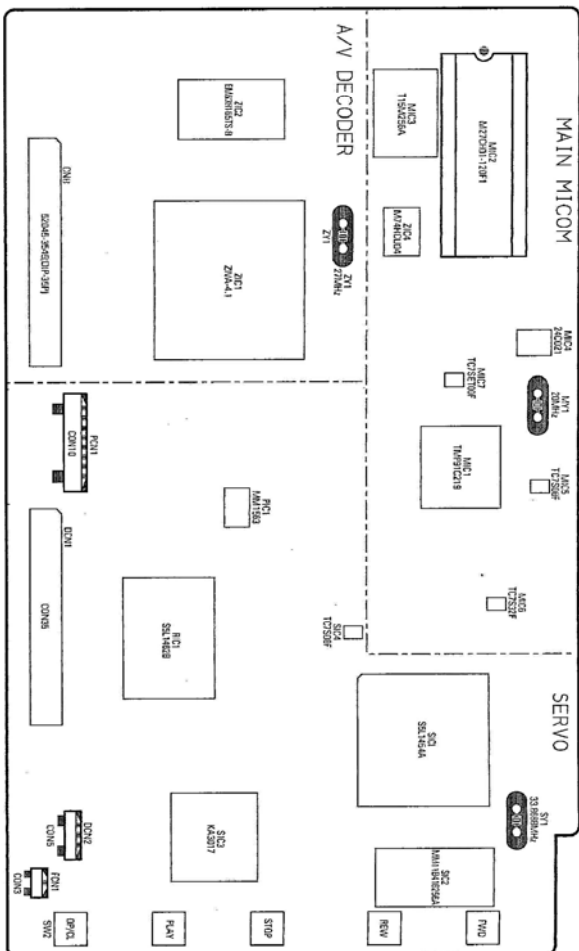

Main PCB (Component Side)

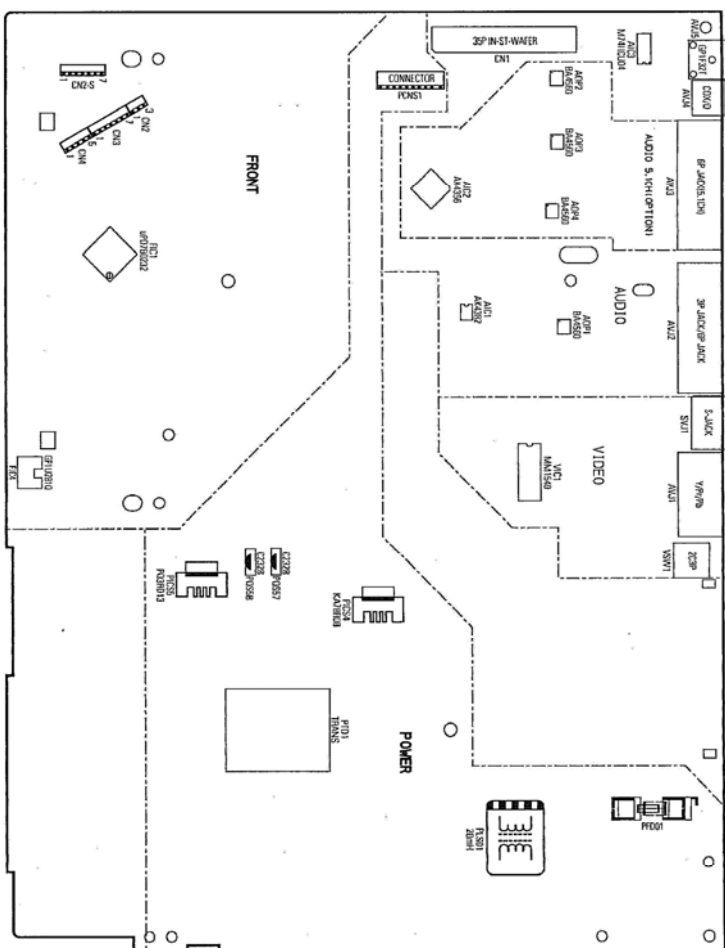

Jack PCB (Conductor Side)

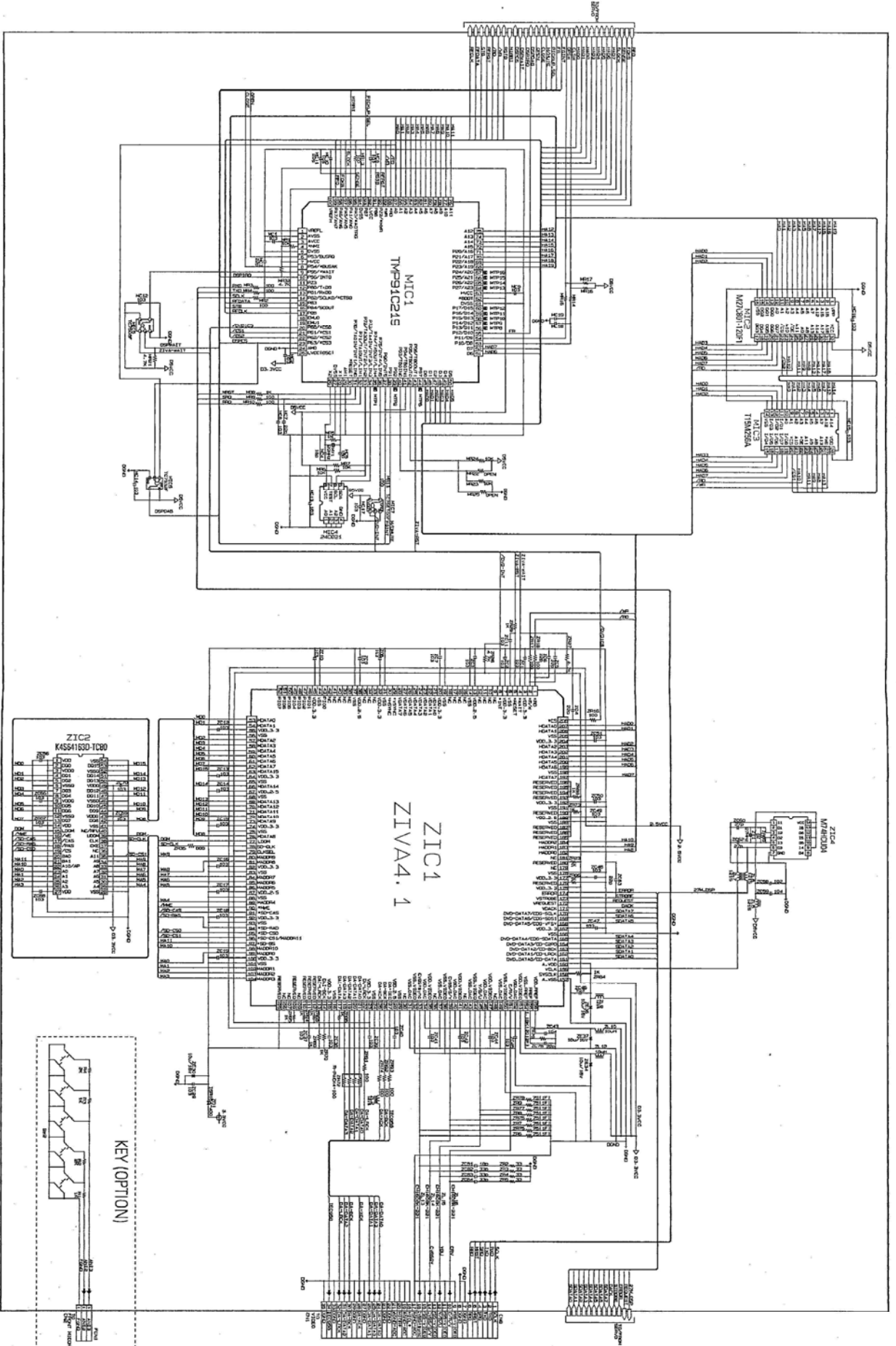

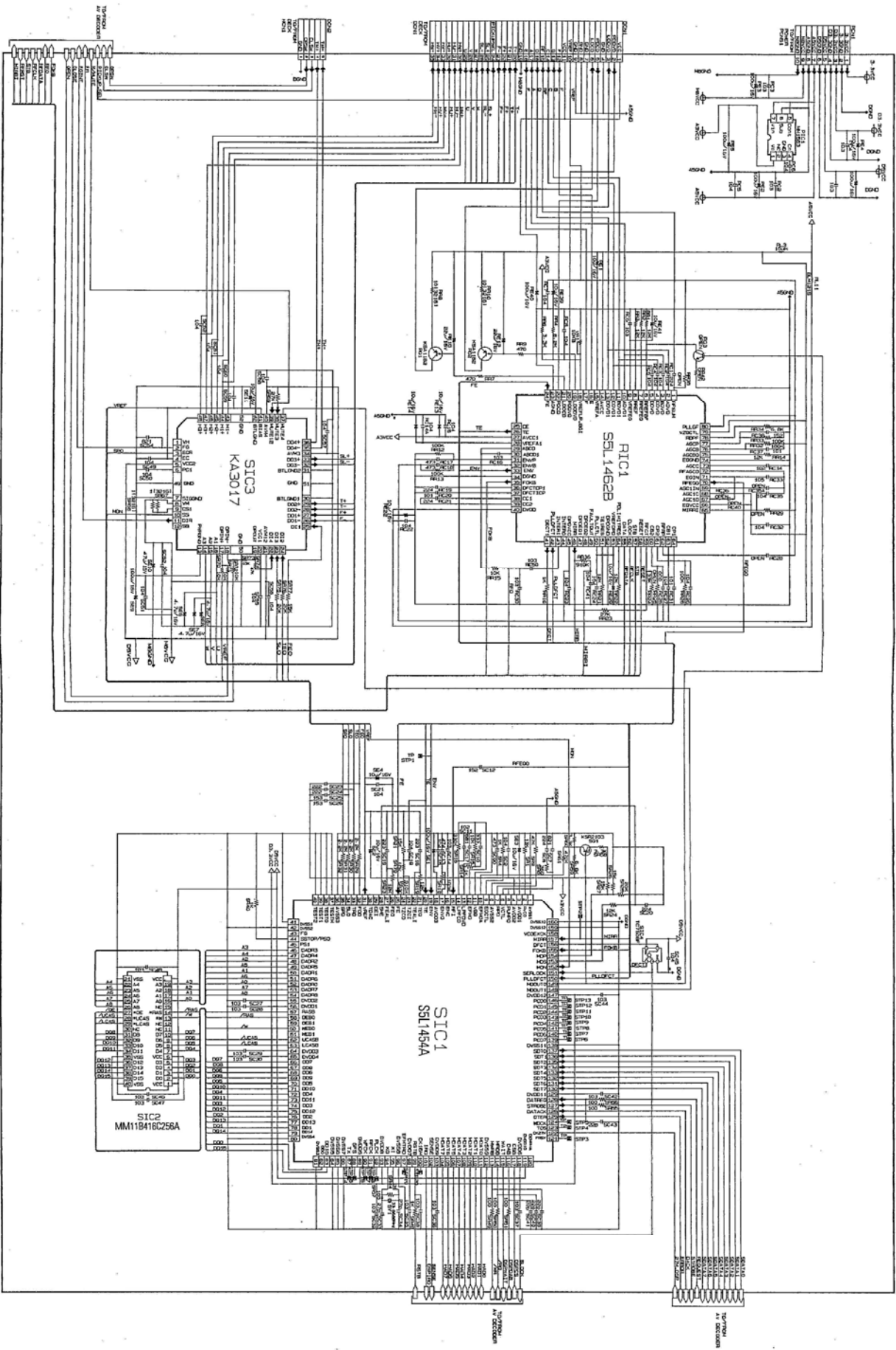

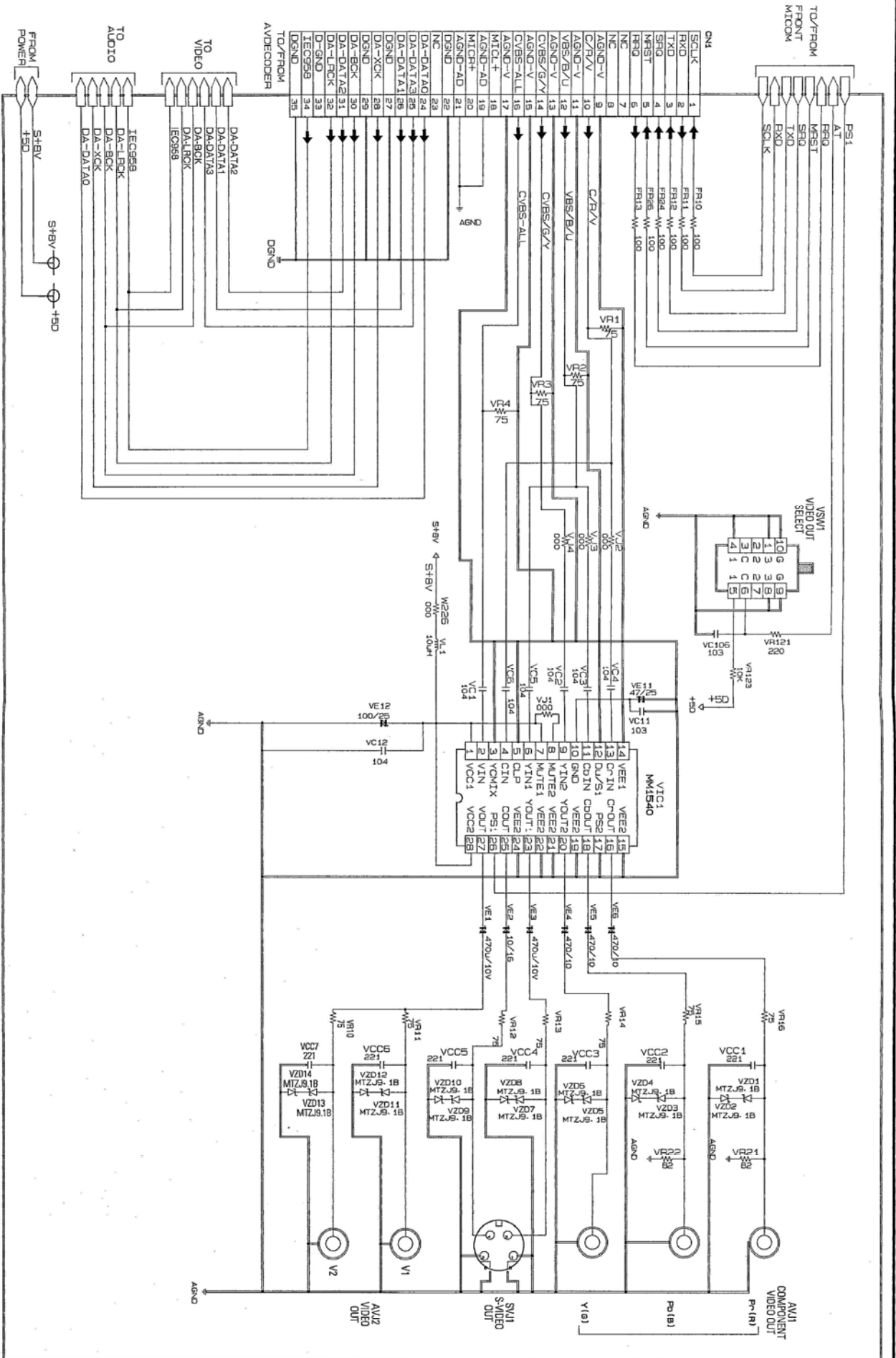

11-7 Front-Micom/VFD Display

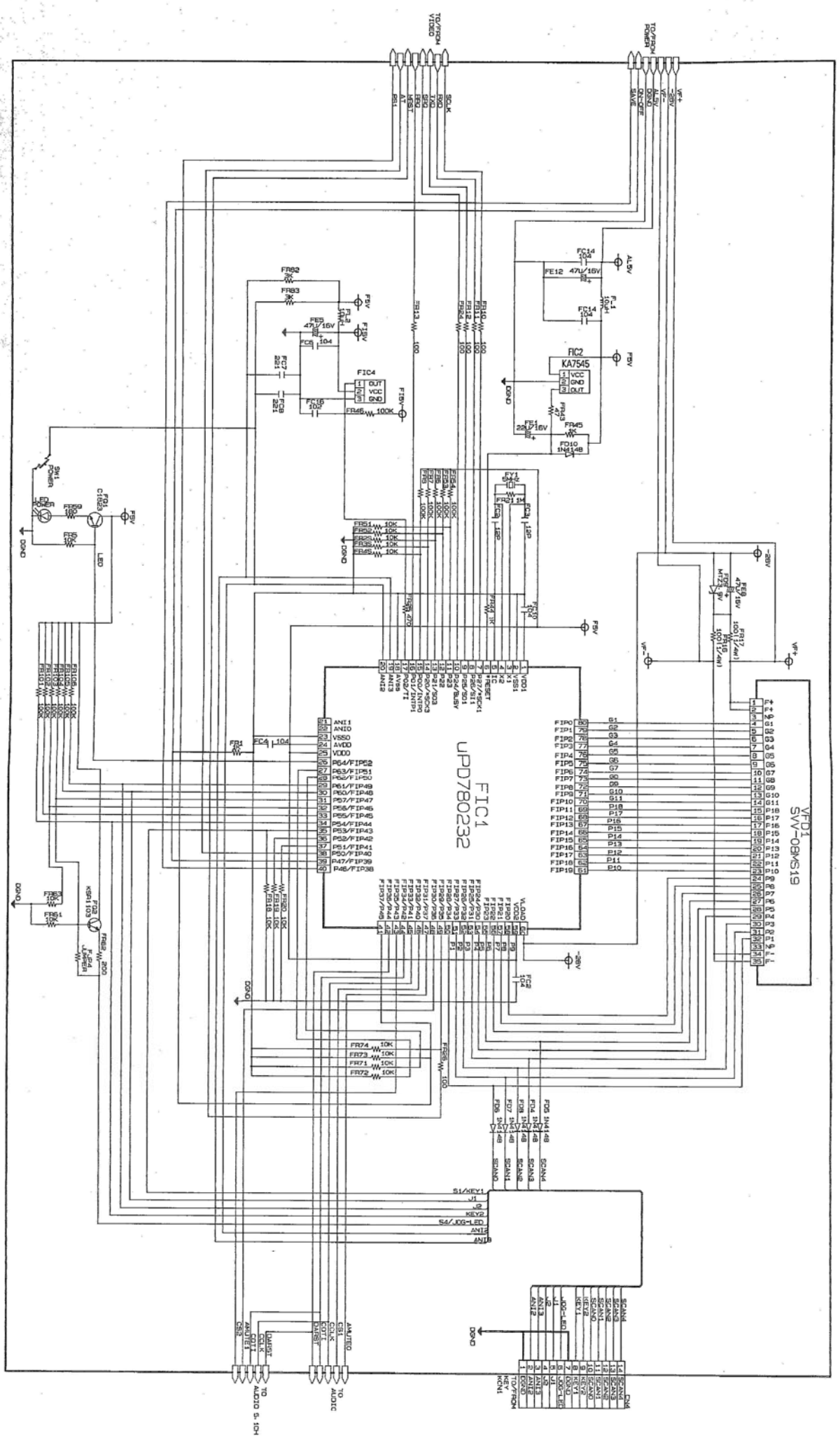

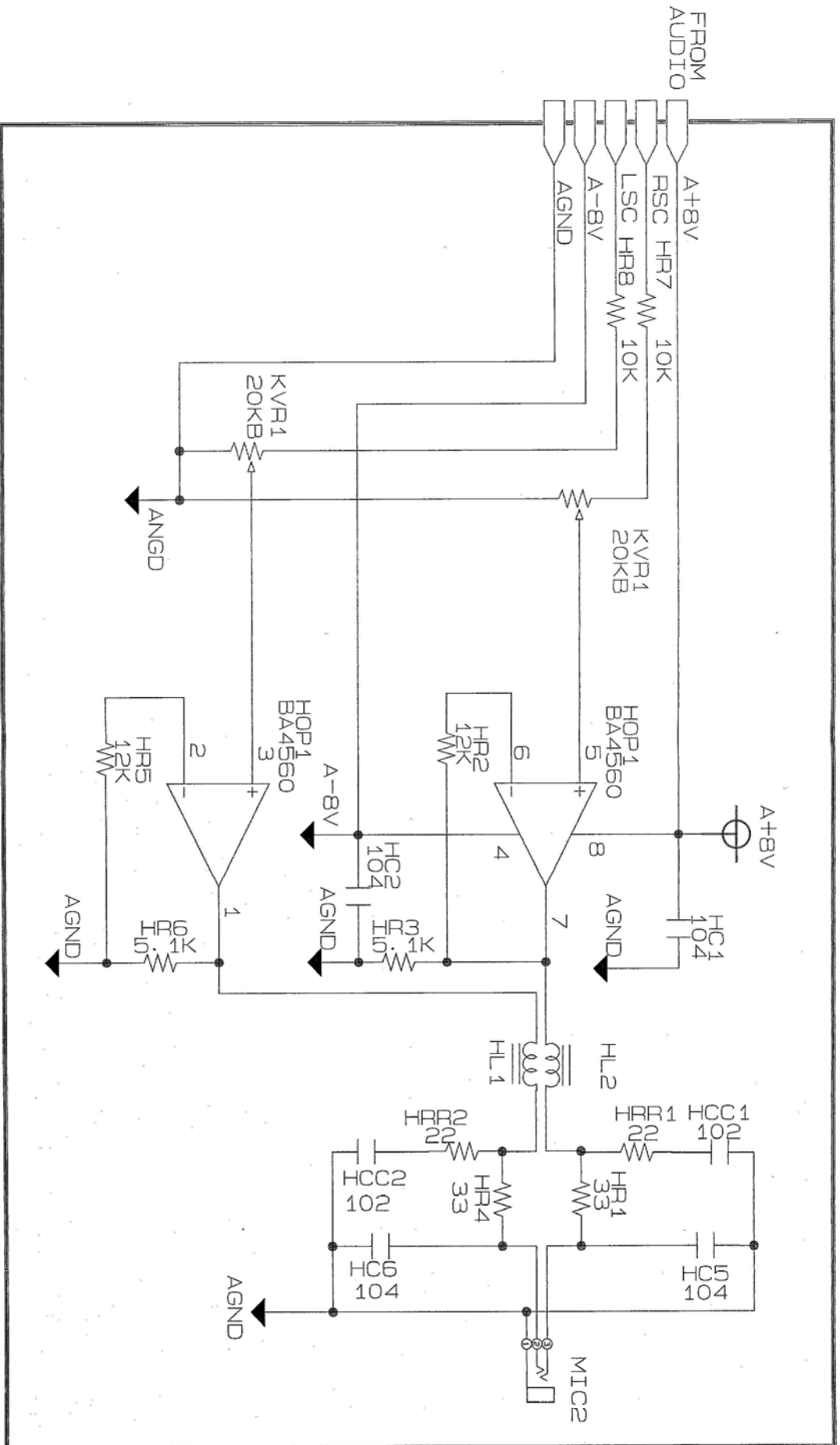

11-9 Key

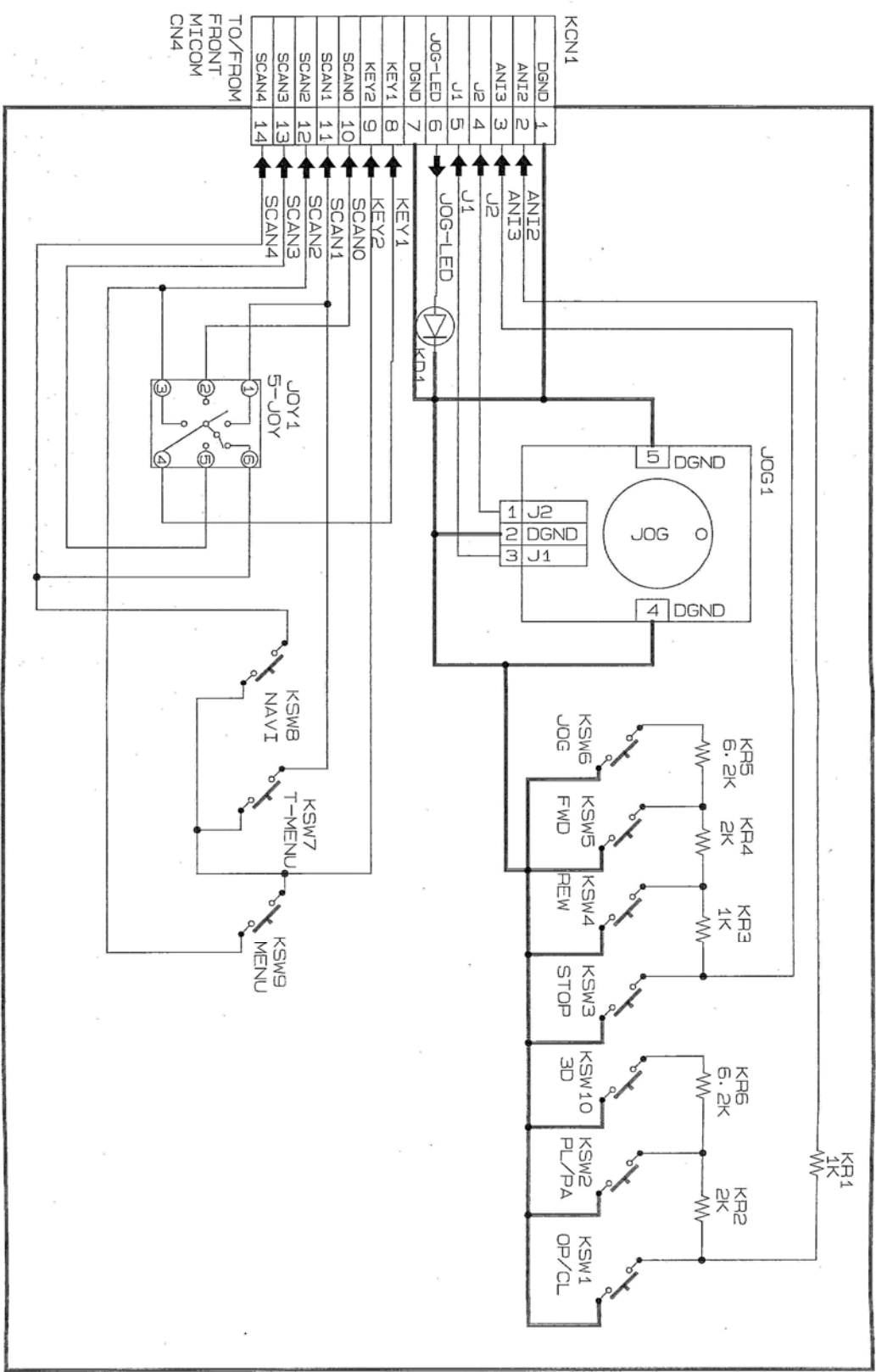

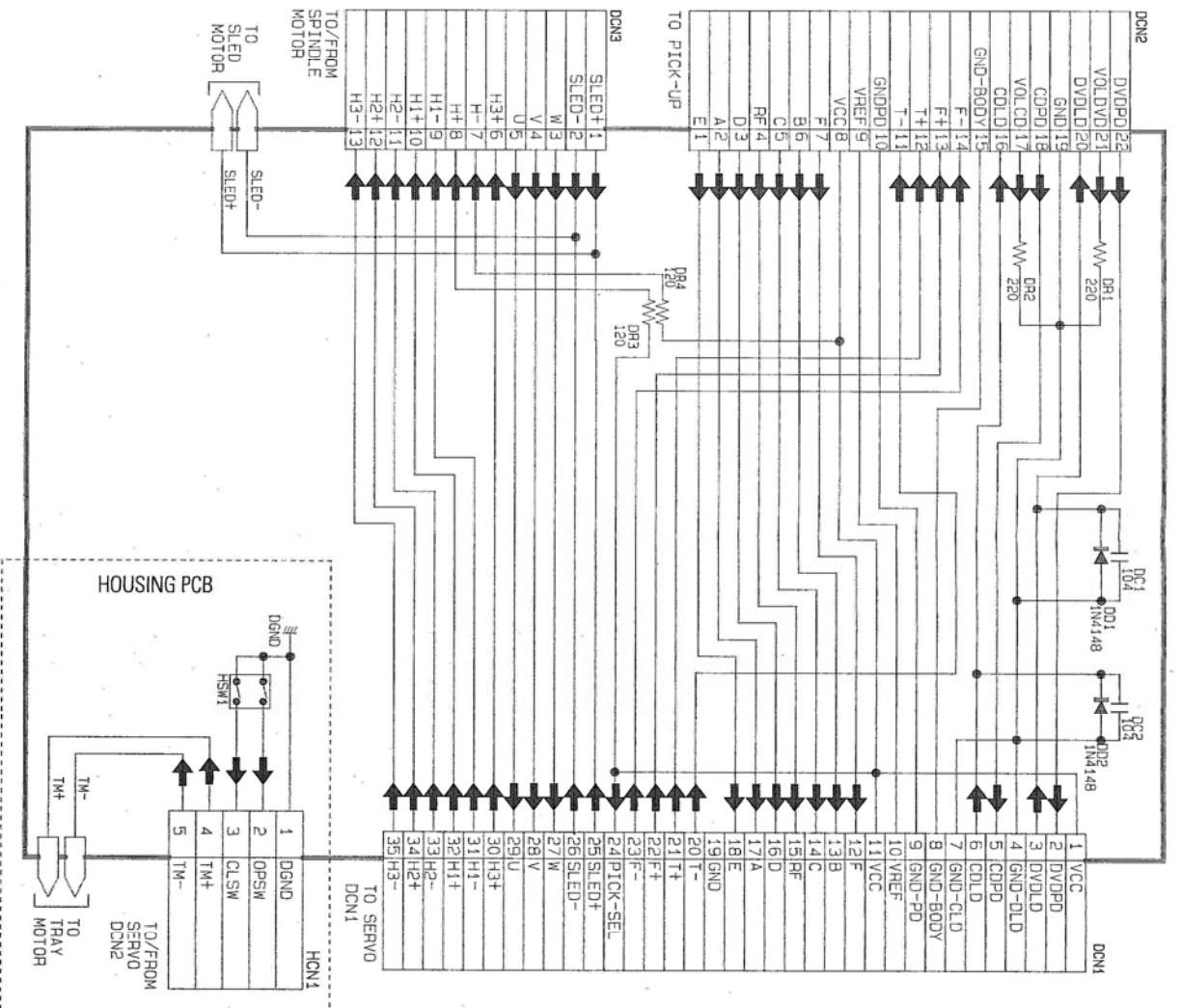

MEMO

HITACHI

DV-P515A(S)

TK No.9114E

Digital Media Products Division, Tokai

Copyright © Hitachi, Ltd. 2001. All rights reserved.

Printed in Japan (II)