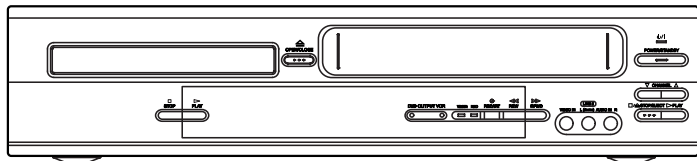


# HITACHI

## SERVICE MANUAL



TK

No. 9302E

**DV-PF73U  
DV-PF73U(C)  
DV-PF33U**

VCR Mechanism Error Codes



SPECIFICATIONS AND PARTS ARE SUBJECT TO CHANGE FOR IMPROVEMENT

## DVD PLAYER & VIDEO CASSETTE RECORDER

February

2003

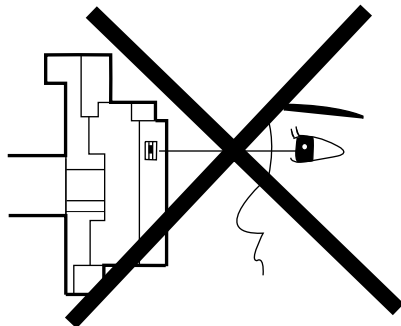
Digital Media Division, Tokai

# CONTENTS

<b>1 CAUTIONS FOR SAFETY IN PERFORMING REPAIR</b> . . . . .	<b>1-1</b>	<b>6 EXPLODED VIEWS AND PARTS LIST</b> . . . . .	<b>6-1</b>
1-1 LASER BEAM SAFETY PRECAUTIONS . . . . .	1-1	6-1 EXPLODED VIEWS . . . . .	6-1
1-2 IMPORTANT SAFETY PRECAUTIONS . . . . .	1-2	6-1-1 Cabinet Section . . . . .	6-1
1-2-1 Product Safety Notice . . . . .	1-2	6-1-2 Deck Mechanism View 1 Section . . . . .	6-2
1-2-2 Precautions during Servicing . . . . .	1-2	6-1-3 Deck Mechanism View 2 Section . . . . .	6-2
1-2-3 Safety Check after Servicing . . . . .	1-3	6-1-4 Deck Mechanism View 3 Section . . . . .	6-3
1-3 STANDARD NOTES FOR SERVICING . . . . .	1-4	6-2 REPLACEMENT PARTS LIST . . . . .	6-4
1-3-1 Circuit Board Indications . . . . .	1-4	6-2-1 Mechanical Parts List . . . . .	6-4
1-3-2 Instructions for Connectors . . . . .	1-4	6-2-2 Electrical Parts List . . . . .	6-6
1-3-3 How to Remove/Install Flat Pack-IC . . . . .	1-4		
1-3-4 Instructions for Handling Semi-conductors . . . . .	1-6		
<b>2 GENERAL INFORMATION</b> . . . . .	<b>2-1</b>	<b>SCHEMATIC AND BLOCK DIAGRAMS/CBA'S</b>	
2-1 SPECIFICATIONS . . . . .	2-1	1 SCHEMATIC DIAGRAMS/CBA'S AND TEST POINTS . . . . .	1
2-2 COMPARISON OF MODELS . . . . .	2-2	2 WIRING DIAGRAMS . . . . .	3
2-2-1 General . . . . .	2-2	2-1 VCR Section . . . . .	3
2-2-2 VCR Section . . . . .	2-2	2-2 DVD Section . . . . .	4
2-2-3 DVD Section . . . . .	2-3	3 SCHEMATIC DIAGRAMS . . . . .	5
2-3 OPERATING CONTROLS AND FUNCTIONS . . . . .	2-4	3-1 Main 1/8 Schematic Diagram . . . . .	5
		3-2 Main 2/8 & Sensor Schematic Diagrams . . . . .	6
<b>3 MAINTENANCE AND INSPECTION</b> . . . . .	<b>3-1</b>	3-3 Main 3/8 Schematic Diagram . . . . .	7
3-1 TROUBLESHOOTING . . . . .	3-1	3-4 Main 4/8 Schematic Diagram . . . . .	8
3-1-1 Power Supply Section . . . . .	3-1	3-5 Main 5/8 Schematic Diagram . . . . .	9
3-1-2 DVD Section . . . . .	3-4	3-6 Main 6/8 Schematic Diagram . . . . .	10
3-1-3 VCR Section . . . . .	3-8	3-7 Main 7/8 & OPEN/CLOSE Schematic Diagrams . . . . .	11
3-2 FIRMWARE RENEWAL MODE . . . . .	3-15	3-8 Main 8/8 Schematic Diagram . . . . .	12
3-2-1 How to Update the Firmware Version . . . . .	3-15	3-9 Power Supply & Junction Schematic Diagrams . . . . .	13
3-2-2 How to Verify the Firmware Version . . . . .	3-16	3-10 Function Schematic Diagram . . . . .	14
3-3 STANDARD MAINTENANCE . . . . .	3-17	3-11 DVD Main 1/3 Schematic Diagram . . . . .	15
3-3-1 Service Schedule of Components . . . . .	3-17	3-12 DVD Main 2/3 Schematic Diagram . . . . .	16
3-3-2 Cleaning . . . . .	3-18	3-13 DVD Main 3/3 Schematic Diagram . . . . .	18
<b>4 ADJUSTMENT</b> . . . . .	<b>4-1</b>	4 WAVEFORMS . . . . .	19
4-1 PREPARATION FOR SERVICING . . . . .	4-1	5 CIRCUIT BOARD DIAGRAMS . . . . .	20
4-1-1 How to Enter the Service Mode . . . . .	4-1	5-1 Main CBA Top View & Sensor CBA Top View . . . . .	20
4-2 FIXTURE AND TAPE FOR ADJUSTMENT . . . . .	4-2	5-2 Main CBA Bottom View . . . . .	21
4-2-1 How to Use The Fixtures . . . . .	4-2	5-3 Function CBA Top/Bottom View & DVD OPEN/CLOSE CBA Top/Bottom View . . . . .	22
4-3 ELECTRICAL ADJUSTMENT INSTRUCTIONS . . . . .	4-3	5-4 Power Supply CBA Top/Bottom View . . . . .	23
4-3-1 Test Equipment Required . . . . .	4-3	6 BLOCK DIAGRAMS . . . . .	24
4-3-2 Head Switching Position Adjustment . . . . .	4-3	6-1 Servo/System Control Block Diagram . . . . .	24
4-4 MECHANICAL ALIGNMENT PROCEDURES . . . . .	4-4	6-2 Video Block Diagram . . . . .	25
4-4-1 Service Information . . . . .	4-4	6-3 Audio Block Diagram . . . . .	26
4-4-2 Tape Interchangeability Alignment . . . . .	4-5	6-4 Hi-Fi Audio Block Diagram . . . . .	27
1-A. Preliminary/Final Checking and Alignment of Tape Path . . . . .	4-6	6-5 Power Supply Block Diagram . . . . .	28
1-B. X Value Alignment . . . . .	4-6	6-6 DVD System Control/Servo Block Diagram . . . . .	29
1-C. Checking/Adjustment of Envelope Waveform . . . . .	4-7	6-7 Digital Signal Process Block Diagram . . . . .	30
1-D. Azimuth Alignment of Audio/Control/Erase Head . . . . .	4-7	6-8 DVD Video / Audio Block Diagram . . . . .	31
		7 SYSTEM CONTROL TIMING CHARTS . . . . .	32
		8 IC PIN FUNCTION DESCRIPTIONS . . . . .	37
		9 LEAD IDENTIFICATIONS . . . . .	40
<b>5 DISASSEMBLY</b> . . . . .	<b>5-1</b>		
5-1 CABINET DISASSEMBLY INSTRUCTIONS . . . . .	5-1		
5-1-1 Disassembly Flowchart . . . . .	5-1		
5-1-2 Disassembly Method . . . . .	5-1		
5-2 DISASSEMBLY/ASSEMBLY PROCEDURES OF DECK MECHANISM . . . . .	5-6		
5-3 ALIGNMENT PROCEDURES OF MECHANISM . . . . .	5-14		

**1-1 LASER BEAM SAFETY PRECAUTIONS**

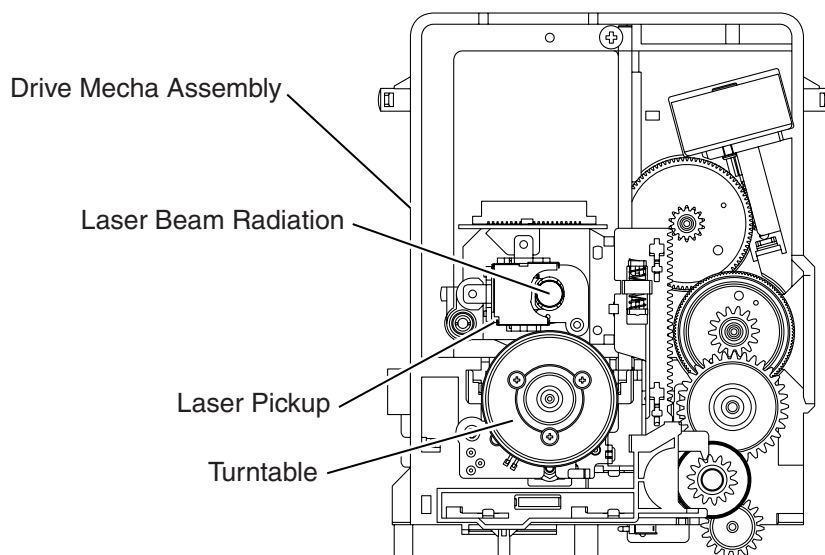
This DVD player uses a pickup that emits a laser beam.



**Do not look directly at the laser beam coming from the pickup or allow it to strike against your skin.**

The laser beam is emitted from the location shown in the figure. When checking the laser diode, be sure to keep your eyes at least 30cm away from the pickup lens when the diode is turned on. Do not look directly at the laser beam.

**Caution:** Use of controls and adjustments, or doing procedures other than those specified herein, may result in hazardous radiation exposure.



**⚠ CAUTION**  
**LASER RADIATION**  
**WHEN OPEN. DO NOT**  
**STARE INTO BEAM.**

**Location: Inside Top of DVD mechanism.**

# 1-2 IMPORTANT SAFETY PRECAUTIONS

## 1-2-1 Product Safety Notice

Some electrical and mechanical parts have special safety-related characteristics which are often not evident from visual inspection, nor can the protection they give necessarily be obtained by replacing them with components rated for higher voltage, wattage, etc. Parts that have special safety characteristics are identified by a **▲** on schematics and in parts lists. Use of a substitute replacement that does not have the same safety characteristics as the recommended replacement part might create shock, fire, and/or other hazards. The Product's Safety is under review continuously and new instructions are issued whenever appropriate. Prior to shipment from the factory, our products are carefully inspected to confirm with the recognized product safety and electrical codes of the countries in which they are to be sold. However, in order to maintain such compliance, it is equally important to implement the following precautions when a set is being serviced.

## 1-2-2 Precautions during Servicing

- A. Parts identified by the **▲** symbol are critical for safety. Replace only with part number specified.
- B. In addition to safety, other parts and assemblies are specified for conformance with regulations applying to spurious radiation. These must also be replaced only with specified replacements.  
Examples: RF converters, RF cables, noise blocking capacitors, and noise blocking filters, etc.
- C. Use specified internal wiring. Note especially:
  - 1) Wires covered with PVC tubing
  - 2) Double insulated wires
  - 3) High voltage leads
- D. Use specified insulating materials for hazardous live parts. Note especially:
  - 1) Insulation tape
  - 2) PVC tubing
  - 3) Spacers
  - 4) Insulators for transistors
- E. When replacing AC primary side components (transformers, power cord, etc.), wrap ends of wires securely about the terminals before soldering.
- F. Observe that the wires do not contact heat producing parts (heatsinks, oxide metal film resistors, fusible resistors, etc.).
- G. Check that replaced wires do not contact sharp edges or pointed parts.
- H. When a power cord has been replaced, check that 5 - 6 kg of force in any direction will not loosen it.

- I. Also check areas surrounding repaired locations.
- J. Be careful that foreign objects (screws, solder droplets, etc.) do not remain inside the set.
- K. Crimp type wire connector  
The power transformer uses crimp type connectors which connect the power cord and the primary side of the transformer. When replacing the transformer, follow these steps carefully and precisely to prevent shock hazards.  
Replacement procedure
  - 1) Remove the old connector by cutting the wires at a point close to the connector.  
**Important:** Do not re-use a connector. (Discard it.)
  - 2) Strip about 15 mm of the insulation from the ends of the wires. If the wires are stranded, twist the strands to avoid frayed conductors.
  - 3) Align the lengths of the wires to be connected. Insert the wires fully into the connector.
  - 4) Use a crimping tool to crimp the metal sleeve at its center. Be sure to crimp fully to the complete closure of the tool.
- L. When connecting or disconnecting the internal connectors, first, disconnect the AC plug from the AC outlet.

## 1-2-3 Safety Check after Servicing

Examine the area surrounding the repaired location for damage or deterioration. Observe that screws, parts, and wires have been returned to their original positions. Afterwards, do the following tests and confirm the specified values to verify compliance with safety standards.

### 1. Clearance Distance

When replacing primary circuit components, confirm specified clearance distance ( $d$ ) and ( $d'$ ) between soldered terminals, and between terminals and surrounding metallic parts. (See Fig. 1)

**Table 1 : Ratings for selected area**

AC Line Voltage	Clearance Distance ( $d$ ) ( $d'$ )
120 V	$\geq 3.2\text{mm}$ (0.126 inches)

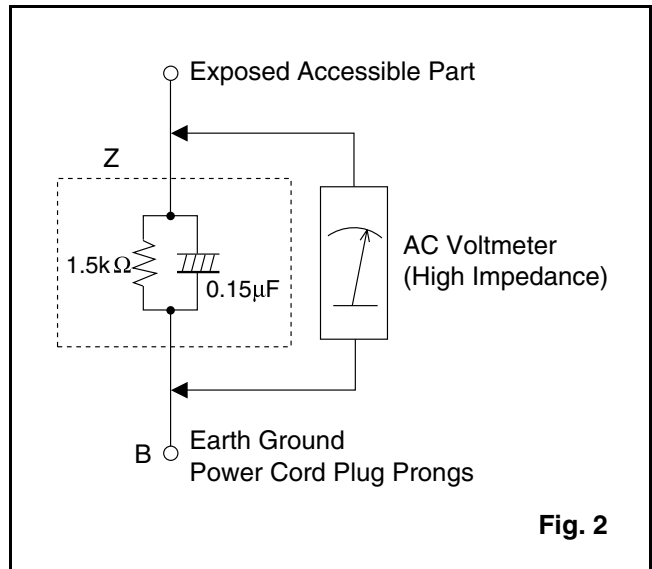
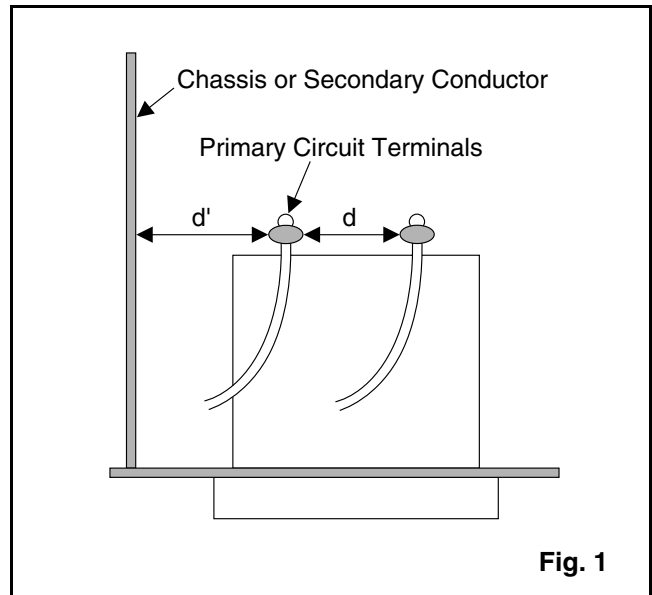
**Note:** This table is unofficial and for reference only. Be sure to confirm the precise values.

### 2. Leakage Current Test

Confirm the specified (or lower) leakage current between B (earth ground, power cord plug prongs) and externally exposed accessible parts (RF terminals, antenna terminals, video and audio input and output terminals, microphone jacks, earphone jacks, etc.) is lower than or equal to the specified value in the table below.

#### Measuring Method (Power ON) :

Insert load Z between B (earth ground, power cord plug prongs) and exposed accessible parts. Use an AC voltmeter to measure across the terminals of load Z. See Fig. 2 and the following table.



**Table 2: Leakage current ratings for selected areas**

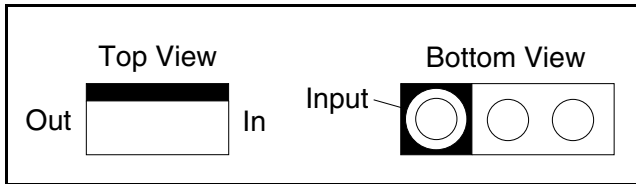
AC Line Voltage	Load Z	Leakage Current ( $i$ )	Earth Ground (B) to:
120 V	0.15 $\mu\text{F}$ CAP. & 1.5k $\Omega$ RES. Connected in parallel	$i \leq 0.5\text{mA}$ Peak	Exposed accessible parts

**Note:** This table is unofficial and for reference only. Be sure to confirm the precise values.

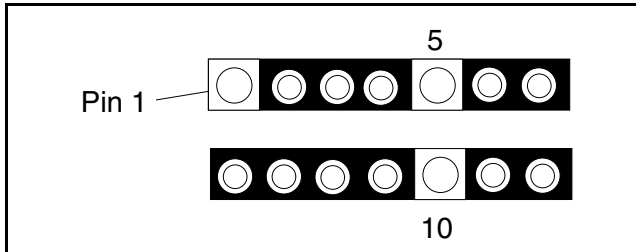
# 1-3 STANDARD NOTES FOR SERVICING

## 1-3-1 Circuit Board Indications

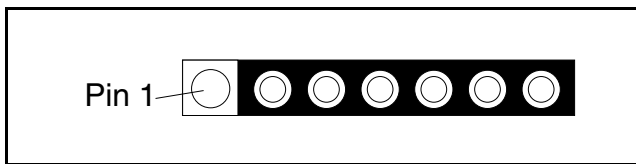
- a. The output pin of the 3 pin Regulator ICs is indicated as shown.



- b. For other ICs, pin 1 and every fifth pin are indicated as shown.

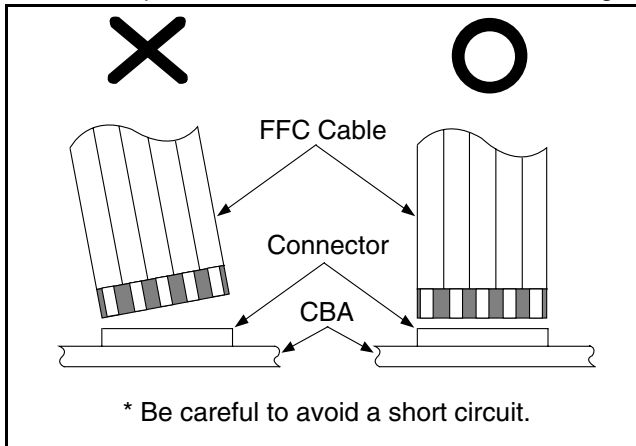


- c. The 1st pin of every male connector is indicated as shown.



## 1-3-2 Instructions for Connectors

- When you connect or disconnect the FFC (Flexible Foil Connector) cable, be sure to first disconnect the AC cord.
- FFC (Flexible Foil Connector) cable should be inserted parallel into the connector, not at an angle.

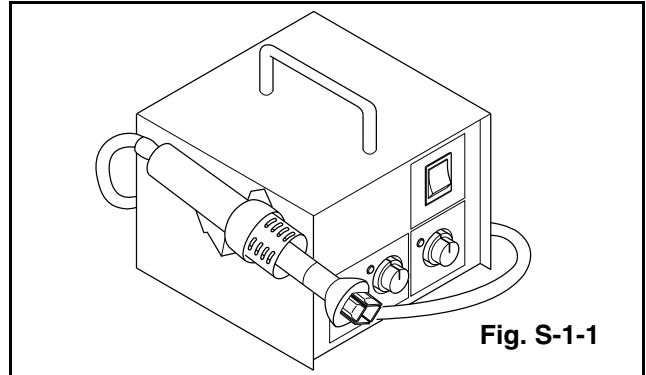


## 1-3-3 How to Remove / Install Flat Pack-IC

### 1. Removal

**With Hot-Air Flat Pack-IC Desoldering Machine:**

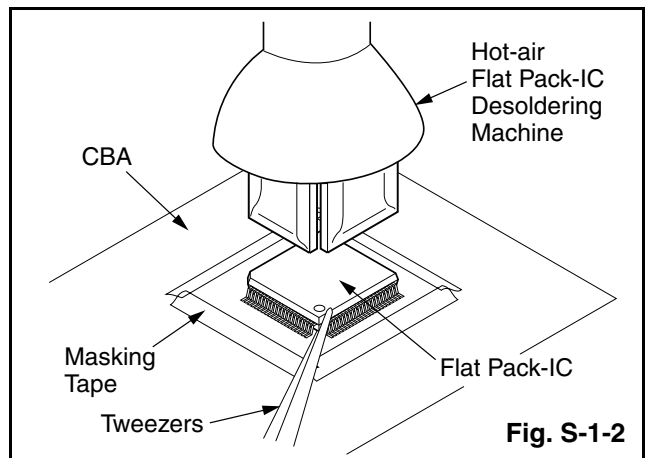
- Prepare the hot-air flat pack-IC desoldering machine, then apply hot air to the Flat Pack-IC (about 5 to 6 seconds). (Fig. S-1-1)



- Remove the flat pack-IC with tweezers while applying the hot air.
- Bottom of the flat pack-IC is fixed with glue to the CBA; when removing entire flat pack-IC, first apply soldering iron to center of the flat pack-IC and heat up. Then remove (glue will be melted). (Fig. S-1-6)
- Release the flat pack-IC from the CBA using tweezers. (Fig. S-1-6)

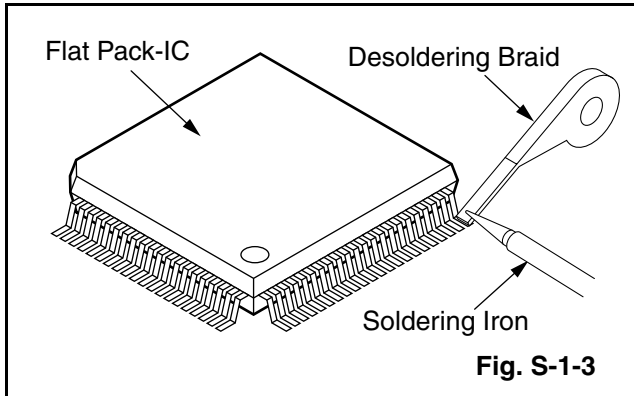
### Caution:

- Do not supply hot air to the chip parts around the flat pack-IC for over 6 seconds because damage to the chip parts may occur. Put masking tape around the flat pack-IC to protect other parts from damage. (Fig. S-1-2)
- The flat pack-IC on the CBA is affixed with glue, so be careful not to break or damage the foil of each pin or the solder lands under the IC when removing it.

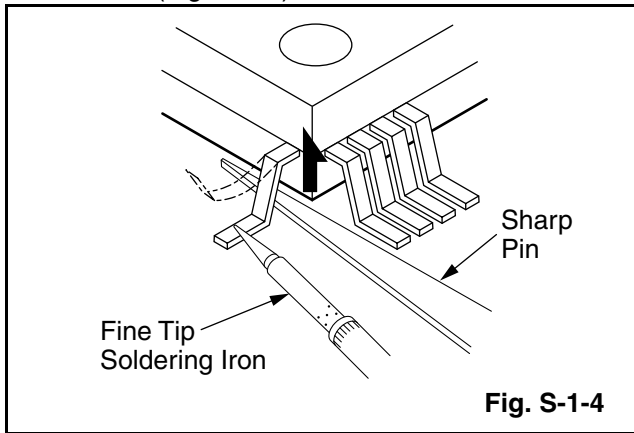


**With Soldering Iron:**

- (1) Using desoldering braid, remove the solder from all pins of the flat pack-IC. When you use solder flux which is applied to all pins of the flat pack-IC, you can remove it easily. (Fig. S-1-3)



- (2) Lift each lead of the flat pack-IC upward one by one, using a sharp pin or wire to which solder will not adhere (iron wire). When heating the pins, use a fine tip soldering iron or a hot air desoldering machine. (Fig. S-1-4)



- (3) Bottom of the flat pack-IC is fixed with glue to the CBA; when removing entire flat pack-IC, first apply soldering iron to center of the flat pack-IC and heat up. Then remove (glue will be melted). (Fig. S-1-6)

- (4) Release the flat pack-IC from the CBA using tweezers. (Fig. S-1-6)

**With Iron Wire:**

- (1) Using desoldering braid, remove the solder from all pins of the flat pack-IC. When you use solder flux which is applied to all pins of the flat pack-IC, you can remove it easily. (Fig. S-1-3)

- (2) Affix the wire to a workbench or solid mounting point, as shown in Fig. S-1-5.

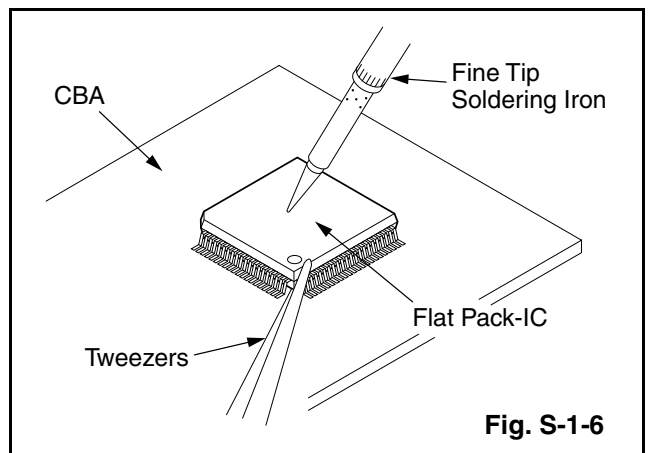
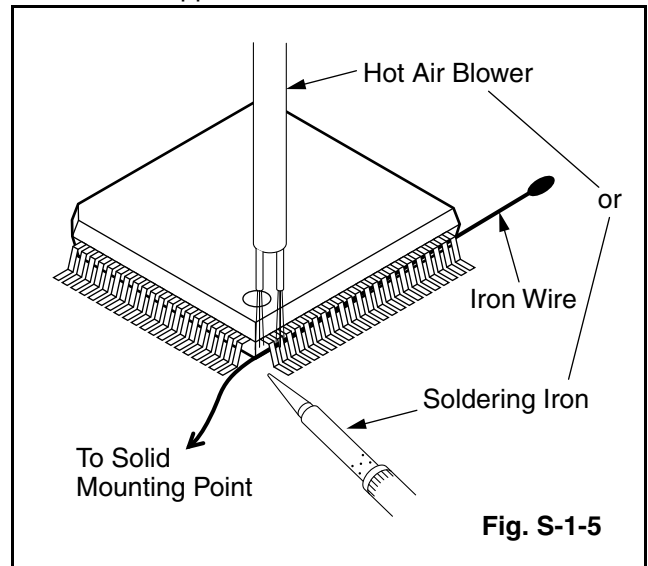
- (3) While heating the pins using a fine tip soldering iron or hot air blower, pull up the wire as the solder melts so as to lift the IC leads from the CBA contact pads as shown in Fig. S-1-5

- (4) Bottom of the flat pack-IC is fixed with glue to the CBA; when removing entire flat pack-IC, first apply soldering iron to center of the flat pack-IC and heat up. Then remove (glue will be melted). (Fig. S-1-6)

- (5) Release the flat pack-IC from the CBA using tweezers. (Fig. S-1-6)

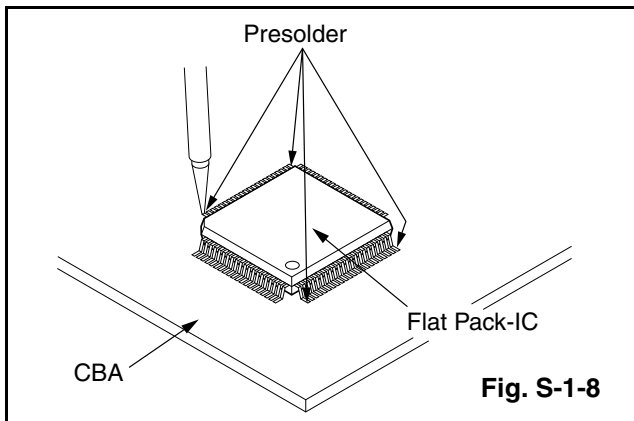
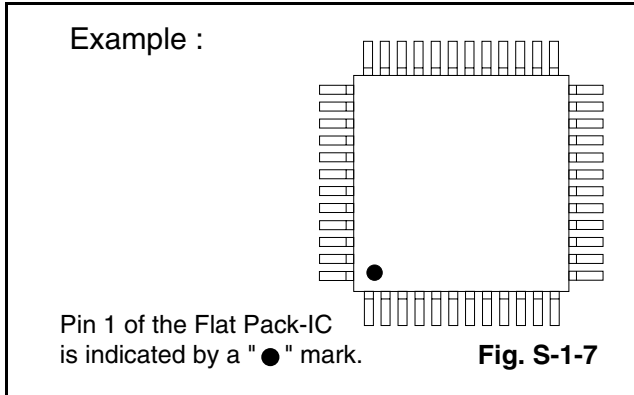
**Note:**

When using a soldering iron, care must be taken to ensure that the flat pack-IC is not being held by glue. When the flat pack-IC is removed from the CBA, handle it gently because it may be damaged if force is applied.



## 2. Installation

- (1) Using desoldering braid, remove the solder from the foil of each pin of the flat pack-IC on the CBA so you can install a replacement flat pack-IC more easily.
- (2) The "●" mark on the flat pack-IC indicates pin 1. (See Fig. S-1-7.) Be sure this mark matches the 1 on the PCB when positioning for installation. Then presolder the four corners of the flat pack-IC. (See Fig. S-1-8.)
- (3) Solder all pins of the flat pack-IC. Be sure that none of the pins have solder bridges.



## 1-3-4 Instructions for Handling Semi-conductors

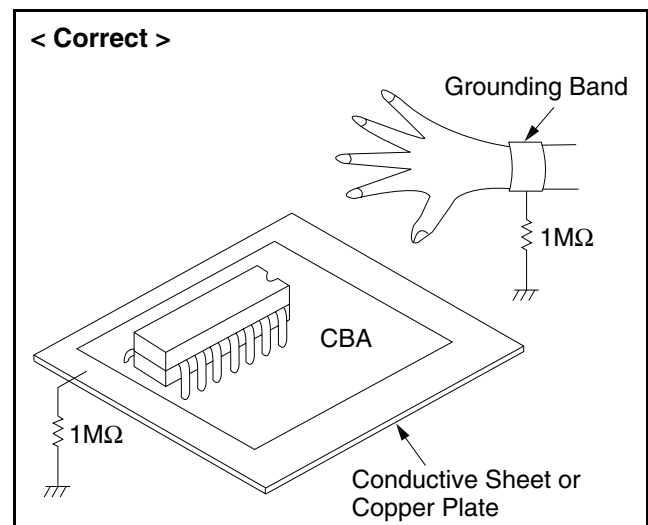
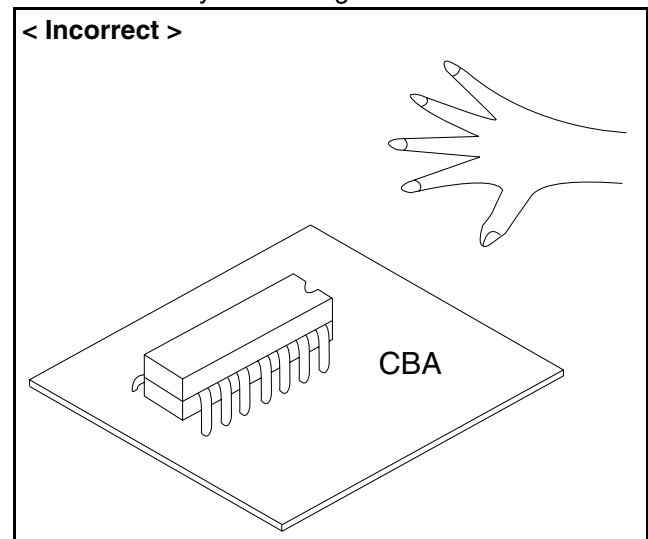
Electrostatic breakdown of the semi-conductors may occur due to a potential difference caused by electrostatic charge during unpacking or repair work.

### 1. Ground for Human Body

Be sure to wear a grounding band ( $1M\Omega$ ) that is properly grounded to remove any static electricity that may be charged on the body.

### 2. Ground for Workbench

- (4) Be sure to place a conductive sheet or copper plate with proper grounding ( $1M\Omega$ ) on the workbench or other surface, where the semi-conductors are to be placed. Because the static electricity charge on clothing will not escape through the body grounding band, be careful to avoid contacting semi-conductors with your clothing.





## 2-1 SPECIFICATIONS

Product type:	DVD/VCR Combo (DVD player with Video Cassette Recorder)
Discs:	DVD video Audio CD Video Cassette tape
Converter output:	VHF Channel 3 or 4.
Power source:	120 V AC +/- 10%, 60 Hz +/- 0.5%
Power consumption:	24 W (standby: 7.0 W)
Operating temperature:	41°F(5°C) to 104°F(40°C)
Dimensions:	W 17-1/8" (435 mm) H 3-7/8" (99 mm) D 8-5/8" (218 mm)
Weight:	8.1 lbs (3.7 kg)

- **Designs and specifications are subject to change without notice.**

## 2-2 COMPARISON OF MODELS

### 2-2-1 General

ITEM		DV-PF73U/PF73U(C)/PF33U	DV-PF2U
APPEARANCE	Dimensional	435(W) x 99(H) x 218(D)mm	435(W) x 99(H) x 266(D)mm
	Weight	3.7kg	4.0kg
	Tray Panel	Clear	←
	Color Front/BUtton	Silver/Silver (DV-PF73U/PF73U(C)) Black/Silver (DV-PF33U)	Silver/Silver
	Hot Stamp	---	←
REMOTE CONTROLLER	Remote Controller Model Name	DV-RMPF73U (DV-PF73U/PF73U(C)) DV-RMPF33U (DV-PF33U)	DV-RMPF2
	Jog Shuttle on Remote	---	←
	TV Control	O (DV-PF73U/PF73U(C)) --- (DV-PF33U)	O

### 2-2-2 VCR Section

←: Same as on left

ITEM		DV-PF73U/PF73U(C)/PF33U	DV-PF2U
VIDEO	Video Format	VHS	←
	Y/C Separation	Comb Filter	←
	YNR (Luminance Noise Reduction) Circuit	O	←
	New Synchronize Circuit	×	←
	Picture Control	×	←
INPUT/ OUTPUT	Video/Audio Input (Rear)	1/1 (IN1)	←
	Video/Audio Input (Front)	1/1 (IN2)	←
	Video/Audio Output (Rear)	1/1 (OUT1)	←
OTHER	Stereo CM Skip Feature	×	O
	Auto Clock Feature	×	O
	Number of Timer Programming	8 Program/year	7 Program/year
	Self Diagnosis Function	O (4 Modes)	---
	Back-up Time	30 s	60 s
	SQPB	×	O
	Surge Absorber	O	←
	Auto Power Off Feature	O	←
	Local Broadcast Setting	O	←
Multi Search Feature	O (Index, Time Search)	←	
MECHANISM	Search Speed	SP: X5 LP: X5/X9 EP: X5/X15	←
	FF/REW Time (T-120 Tape)	FF: approx. 4 min, REW: approx. 4 min	←
	Head Composition	DA4+Hi-Fi SP: 2[49/58 μm] EP: 2[21/21 μm] Hi-Fi Audio: 2[28/28 μm]	←
	Video Head Material	SP: Ferrite EP: Ferrite Hi-Fi Audio: Ferrite	←
	VISS	O (Index Search)	←

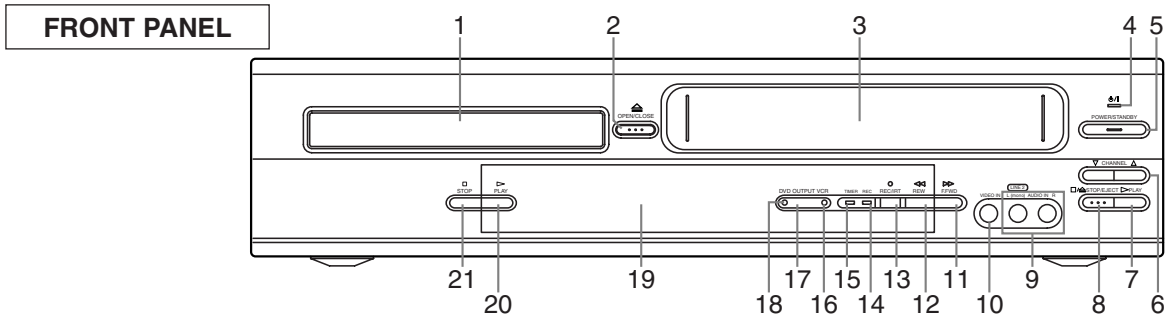
## 2-2-3 DVD Section

←: Same as on left

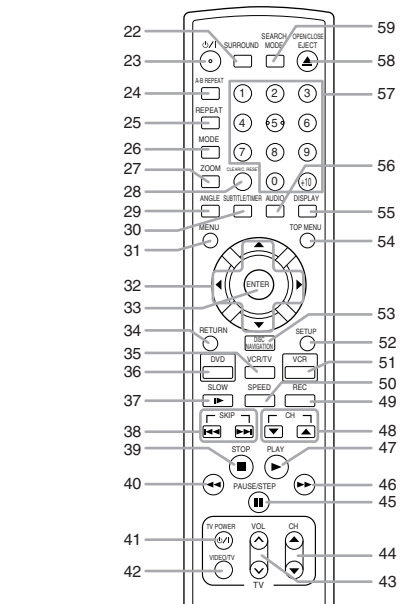
	ITEM	DV-PF73U/PF73U(C)/PF33U	DV-PF2U
GENERAL	Drive Speed	1x	←
	Laser	2	←
	DVD/VCD/SVCD/CD-DA	O / --- / --- / O	←
	CD-R/CD-RW/DVD-R (Video Format)	O / O / O	←
	DVD-RAM (VR Format)	---	←
	MP3	O	←
	OSD languages	3 (English, French, Spanish)	←
	Jog Shuttle on Front	---	←
	Headphone Jack / Volume	---/---	←
VIDEO	PAL Disc NTSC Out	---	←
	Video Out Mode NTSC/PAL/PAL60	O / --- / ---	←
	S-Video / Component / Composite	O / O / O	←
	Video D/A Converter	10bit	←
	Black Level Select	O	←
	Picture Control	---	←
	Progressive Out	O	---
AUDIO	Audio D/A Converter	192kHz / 24bit	←
	Digital Audio Out Optical / Coaxial	--- / O	O / O
	Dolby Digital 5.1 ch Decode	---	←
	DTS Digital Out	---	O
	Virtual Surround	O	←
	Dynamic Range Compression (Dolby Digital)	O	←
	DVD Audio	---	←
	Power on sound	---	←
TRICK PLAY	Search Speed	2 to 100 (FORWARD/REWIND) (DVD: 2, 8, 50, 100/CD: 16)	2 to 60 (FORWARD/REWIND) (DVD: 2, 8, 30, 60/CD: 16)
	Slow Speed	1/16, 1/8, 1/2 (FORWARD/REWIND)	1/16, 1/8, 1/2 (FORWARD only)
	IP Search (Smooth 2x Play)	O	←
	2x Play with Audio	---	←
	Step Forward / Reverse	O / O	O / ---
	Still Picture Select (Frame/Field)	Auto Only	←
FEATURES	Disc Navigation	O (DV-PF73U/PF73U(C)) --- (DV-PF33U)	---
	DVD Zoom x2 / x4	O / O	←
	Program and Random Play of DVD / VCD	---	O / O
	A-B Repeat	O	←
	Repeat	O	←
	Last Play	O	←
	Closed Caption for NTSC DVD	O	←
	Front Panel Display Dimmer	O	←
	Screen Saver	O	←
	Auto Power Off	O	←

# 2-3 OPERATING CONTROLS AND FUNCTIONS

[ DV-PF73U/PF73U(C) ]



## REMOTE CONTROL



1. **Disc loading tray**
2. **OPEN/CLOSE Button**  
Press to insert discs into or remove them from the tray.
3. **CASSETTE COMPARTMENT**
4. **POWER Light**  
Lights up when the power is on.
5. **POWER/STANDBY Button**  
Press to turn the power on and off.
6. **CHANNEL Buttons**  
In VCR mode, press to change TV channels on the VCR; press to adjust the tracking during normal or slow motion playback; press to remove vertical jitter in a Still picture.
7. **PLAY Button(VCR)**  
Press to begin playback.
8. **STOP/EJECT Button (VCR)**  
**EJECT Button**  
Press to remove the tape from the VCR.  
**STOP Button**  
Press to stop the tape motion.
9. **AUDIO In Jacks**  
Connect audio cables coming from the audio out jacks of a camcorder, another VCR, or an audio source here.
10. **VIDEO In Jack**  
Connect a video cable coming from the video out jack of a camcorder, another VCR, or a video source (laser disc player, camcorder, etc.) here.
11. **F.FWD Button (VCR)**  
Press to rapidly advance the tape, or view the picture rapidly in forward during playback. (Forward Search).

12. **REW Button (VCR)**  
Press to rewind the tape, or to view the picture rapidly in reverse during the playback mode (Rewind Search).
13. **REC/IRT Button**  
Press once to start a recording. Press repeatedly to start a Instant Recording Timer.
14. **REC Light**  
Lights up during recording.
15. **TIMER Light**  
This light glows when the DVD/VCR is in standby mode or off for a timer recording or during a Instant Recording Timer. It flashes if TIMER is pressed for a timer recording, but there is no tape in the DVD/VCR. It flashes when all timer recordings or Instant Recording Timer, are finished.
16. **VCR OUTPUT Light (Green)**  
This light appears when the VCR output mode is selected. You can only watch tapes when the green VCR OUTPUT light is on. To make the green VCR OUTPUT light come on, VCR on the remote control or OUTPUT on the front panel.
17. **OUTPUT Button**  
Press to select DVD mode or VCR mode.  
● You can switch the output mode either by pressing OUTPUT on the front panel, or by pressing DVD or VCR on the remote control. However, **if you press OUTPUT on the front panel first, you need to re-select the corresponding mode by pressing DVD or VCR on the remote control.**
18. **DVD OUTPUT Light (Green)**  
This light appears when the DVD output mode is selected. You can only watch DVDs when the green DVD OUTPUT Light is on. To make the green DVD OUTPUT light come on, press DVD on the remote control or OUTPUT on the front panel.
19. **Display, Remote Sensor Window**
20. **PLAY Button (DVD)**  
Press to begin playback.
21. **STOP Button (DVD)**  
Stops operation of the disc.
22. **SURROUND Button**  
Press to activate the 3D sound.
23. **⏻/⏻(POWER/STANDBY) Button**  
Press to turn the power on and off.  
(As to the indication of the Operate switch, "I" shows ON and "⏻/⏻" shows electrical power stand-by.)
24. **A-B REPEAT Button**  
Repeats playback of a selected section.
25. **REPEAT Button**  
Repeats playback of the current disc, title, chapter or track.
26. **MODE Button**  
Activates program playback or random playback mode when playing CDs or MP3. Sets Black level and virtual surround.
27. **ZOOM Button**  
Enlarges part of a DVD-reproduced image.

28. **CLEAR/C.RESET Button**
- **DVD mode**  
Press to reset the setting.
  - **VCR mode**  
Press to reset the counter. Press to exit from the MENU screen.
29. **ANGLE Button**  
Press to change the camera angle to see the sequence being played back from a different angle.
30. **SUBTITLE Button**  
Press to select the desired subtitle language.
- TIMER Button**  
Press to put the VCR into standby mode for a timer recording.
31. **MENU Button**
- **DVD mode**  
Press to display the menu of the Disc.
  - **VCR mode**  
Press to access the VCR menu.
32. **Arrow Buttons**
- **DVD mode**
  - ▼/▲ ► ◀ **Buttons**  
Move the cursor and determines its position.
  - **VCR mode**
  - ▼/▲ **Buttons**  
Press to enter digits when setting program (For example: setting clock or timer program). Press to select the setting modes from the on screen menu.
  - **Button**  
When setting program (For example: setting clock or timer program), press to determine your selection and proceed to the next step you want to input. Press to determine the setting modes from the on screen menu. Press to add or delete channel numbers during channel preset.
  - ◀ **Button**  
Press to cancel a setting of timer program. Press to correct digits when setting program (For example: setting clock or timer program). Press to add or delete channel numbers during channel preset.
33. **ENTER Button**  
Press to accept a setting.
34. **RETURN Button**  
Returns to the previous operation.
35. **VCR/TV Button**  
Use to select VCR or TV position.  
This DVD/VCR does not have VCR/TV light. If noise appears on your TV when you turn on DVD/VCR(VCR mode), press this button.
- **VCR Position**  
To view playback, to monitor video recordings or to watch TV using the VCR tuner.
  - **TV Position**  
To watch TV or to view one program while recording another.
- DISC NAVIGATION Button**  
Use to DISC NAVIGATION function.
36. **DVD Button**  
Press to select DVD mode for the remote control.
- You can switch the OUTPUT mode either by pressing OUTPUT on the front panel, or by pressing DVD or VCR on the remote control. However, **if you press OUTPUT on the front panel first, you need to re-select the corresponding mode by pressing DVD or VCR on the remote control.**
37. **SLOW Button**  
During tape playback, press to view the video tape in slow motion. Press again to resume normal playback. This button does not affect DVD playback.
38. **SKIP Buttons**
- **DVD mode**  
Press to skip Chapters or Tracks.
39. **STOP Button**
- **DVD mode**  
Press to stop the disc motion.
  - **VCR mode**  
Press to stop the tape motion.
40. ◀◀ **Button**
- **DVD mode**  
Press to view the DVD picture in fast reverse motion or to reverse playback of an Audio CD.
  - **VCR mode**  
Press to rewind the tape, or to view the picture rapidly in reverse during the playback mode (Rewind Search).
41. **TV POWER Button**  
To exclusively turn ON/OFF the TV.
42. **VIDEO/TV Button**  
Press to select the external input mode or TV mode of the TV.
43. **VOL ▼/▲ Buttons**  
Press to exclusively control the TV volume.
44. **TV CH ▼/▲ Buttons**  
Press to exclusively control the TV channels.
45. **PAUSE/STEP Button**
- **DVD mode**  
Press to pause Disc playback. Press repeatedly to advance the DVD picture step by step (or one frame at a time).
  - **VCR mode**  
While recording, press to temporarily stop the recording (pause). Press a second time to resume normal recording. You can not pause a Instant Recording Timer. Or, press during tape playback to freeze the picture. Press to advance the picture one frame at a time during still mode.
46. ►► **Button**
- **DVD mode**  
Press to fast forward the Disc. Press PAUSE/STEP, then press this button to begin slow motion playback. Press this button repeatedly to change the forward speed of slow motion.
  - **VCR mode**  
Press to rapidly advance the tape, or view the picture rapidly in forward during playback (Forward Search).
47. **PLAY Button**
- **DVD mode**  
Press to begin playback.
  - **VCR mode**  
Press to begin playback.
48. **CH Button**  
Press to change TV channels on the DVD/VCR.
49. **REC Button**  
Press once to start a recording.
50. **SPEED Button**  
Press to select the VCR's recording speed (SP or SLP)
51. **VCR Button**  
Press to select VCR mode for the remote control.
- You can switch the OUTPUT mode either by pressing OUTPUT on the front panel, or by pressing DVD or VCR on the remote control. However, **if you press OUTPUT on the front panel first, you need to re-select the corresponding mode by pressing DVD or VCR on the remote control.**
52. **SETUP Button**  
Press to enter the setup mode.
53. **DISC NAVIGATION Button**  
Press to display the first scenes of each chapter of the title being played.
54. **TOP MENU Button**  
Press to call up the title menu.
55. **DISPLAY Button**
- **DVD mode**  
Press to access or remove the display screen during DVD or Audio CD playback.
  - **VCR mode**  
Press to access or remove the VCR's on-screen status display.
56. **AUDIO Button**  
Press to select a desired audio language or sound mode.

**57. Number Buttons**

- **DVD mode**  
Press to directly select a Track (Audio CD) for playback.
- **VCR mode**  
Press to select TV channels on the VCR.  
To select channels, enter channel numbers as a two-digit number for the quickest results. For example, to select channel 6, press 0 then 6.

**58. OPEN/CLOSE Button**

Press to open or close the disc loading tray.

**EJECT Button**

Press to eject the video cassette from the VCR.

**59. SEARCH MODE Button**

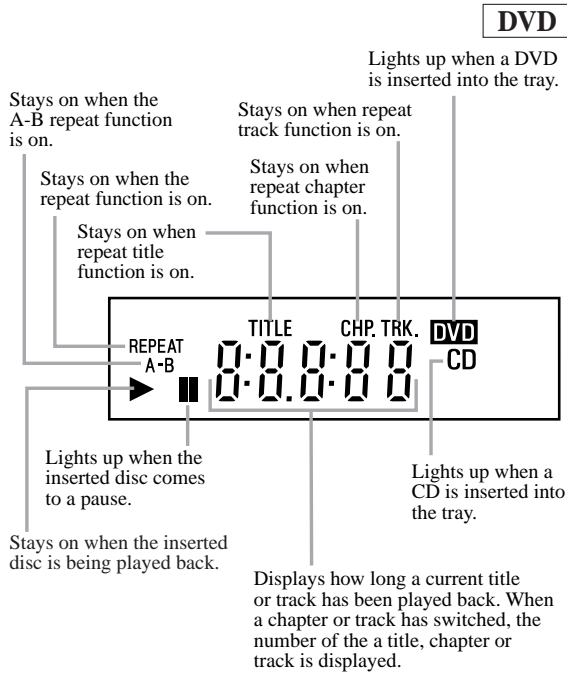
- **DVD mode**  
Press to access or remove the Search display, which allows you to go directly to a specific Title/Chapter/Track/Time.
- **VCR mode**  
Press to perform a Time Search or an Index Search.

**Caution: Do not touch the inner pins of the jacks on the rear panel. Electrostatic discharge may cause permanent damage to the DVD/VCR.**

**Notes**

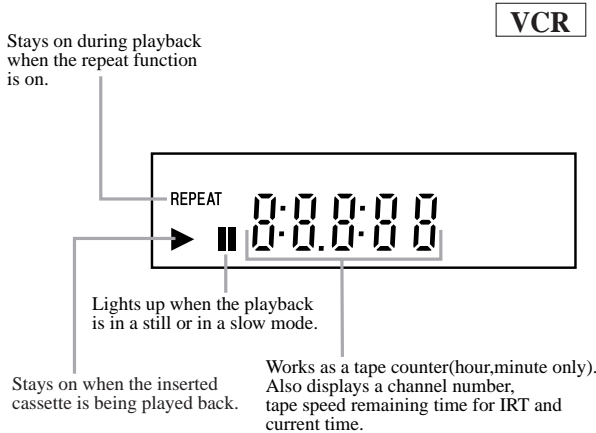
- To use the remote control to operate the DVD/VCR and its features, press DVD on the remote control before pressing other DVD. Verify that the green DVD OUTPUT Light is on.
- To use the remote control to operate the VCR and its features, press VCR on the remote control before pressing other VCR. Verify that the green VCR OUTPUT Light is on.

**DISPLAY**

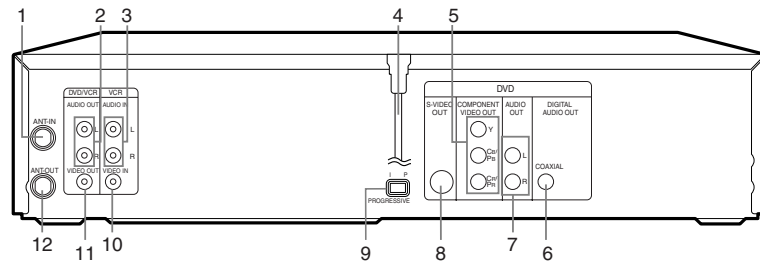


**DISPLAYS DURING OPERATION**

	No disc inserted or playing DVD menu
	Tray open
	Tray closed
	Loading the Disc



## REAR VIEW



### 1. ANT-IN (Antenna In) Jack

Connect your antenna, Cable Box, or Direct Broadcast System.

### 2. DVD/VCR AUDIO OUT Jacks

Connect the supplied audio cables here and to the Audio In jacks of a television or other audio equipment.

### 3. AUDIO IN Jacks (VCR only)

Connect audio cables coming from the audio out jacks of a camcorder, another VCR, or an audio source here.

### 4. AC Power Cord

Connect to a standard AC outlet to supply power to the DVD/VCR.

### 5. COMPONENT VIDEO OUT Jacks (DVD only)

Connect optional component video cables here and to the component Video In jacks of a television.

### 6. COAXIAL Jack (DVD only)

Connect an optional coaxial digital audio cable here and to the Coaxial Digital Audio In jack of a decoder or audio receiver.

### 7. DVD AUDIO OUT Jacks (DVD only)

Connect the supplied audio cables here and to the Audio

In jacks of a television or other audio equipment (DVD only).

### 8. S-VIDEO OUT Jack (DVD only)

Connect an optional S-Video cable here and to the S-Video In jack of a television.

### 9. INTERLACE/PROGRESSIVE SCAN SELECTOR

To select interlace or progressive scanning.

### 10. VIDEO IN Jack (VCR only)

Connect a cable coming from the video out jack of a camcorder, another VCR, or an audio-visual source (laser disc player, video disc player, etc.) here.

### 11. DVD/VCR VIDEO OUT Jack

Connect the yellow video cable (supplied) here and to the TV's Video In jack.

If you select P(PROGRESSIVE) in INTERLACE/PROGRESSIVE SCAN SELECTOR, DVD video signal is not output to your TV.

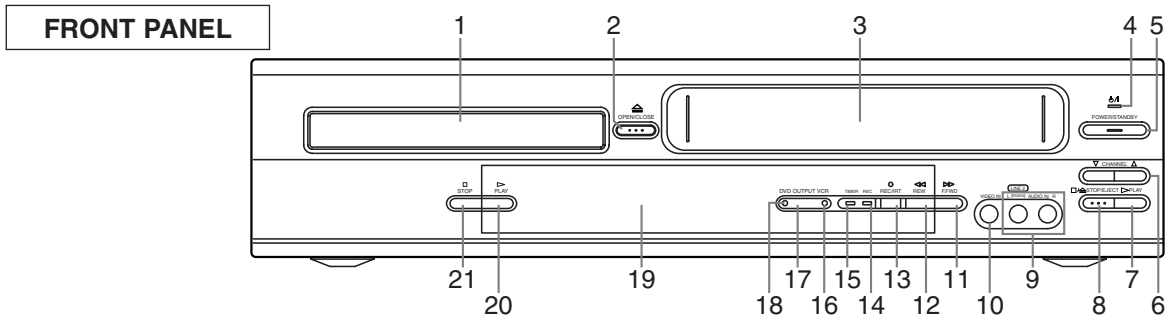
### 12. ANT-OUT (Antenna Out) Jack

Use the supplied RF coaxial cable to connect this jack to the ANTENNA IN Jack on your TV.

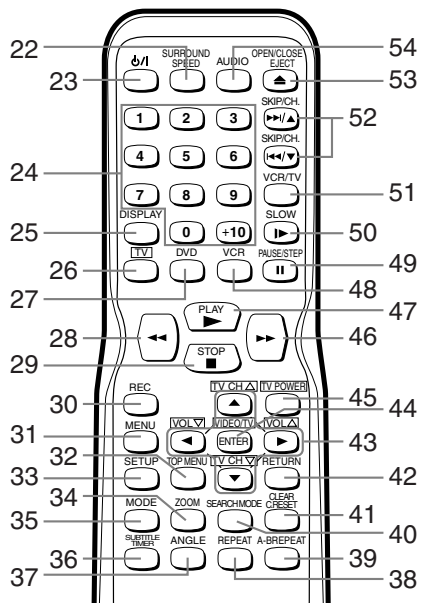
## CAUTION:

- Be sure to turn off the DVD/VCR and equipment to be connected before connecting.
- Read through the operation manual for the equipment to be connected.
- Be sure that the colors of the jacks and plugs match up when using VIDEO/AUDIO cables.
- Be sure to keep the DVD/VCR connection cables separate from the TV antenna cable when you install the DVD/VCR, because it may cause electrical interference when you are watching television programs.

# [ DV-PF33U ]



## REMOTE CONTROL



1. **Disc loading tray**
2. **OPEN/CLOSE Button**  
Press to insert discs into or remove them from the tray.
3. **CASSETTE COMPARTMENT**
4. **POWER Light**  
Lights up when the power is on.
5. **POWER/STANDBY Button**  
Press to turn the power on and off.
6. **CHANNEL Buttons**  
In VCR mode, press to change TV channels on the VCR; press to adjust the tracking during normal or slow motion playback; press to remove vertical jitter in a Still picture.
7. **PLAY Button(VCR)**  
Press to begin playback.
8. **STOP/EJECT Button (VCR)**  
**EJECT Button**  
Press to remove the tape from the VCR.  
**STOP Button**  
Press to stop the tape motion.
9. **AUDIO In Jacks**  
Connect audio cables coming from the audio out jacks of a camcorder, another VCR, or an audio source here.
10. **VIDEO In Jack**  
Connect a video cable coming from the video out jack of a camcorder, another VCR, or a video source (laser disc player, camcorder, etc.) here.
11. **F.FWD Button (VCR)**  
Press to rapidly advance the tape, or view the picture rapidly in forward during playback. (Forward Search).

12. **REW Button (VCR)**  
Press to rewind the tape, or to view the picture rapidly in reverse during the playback mode (Rewind Search).
13. **REC/IRT Button**  
Press once to start a recording. Press repeatedly to start a Instant Recording Timer.
14. **REC Light**  
Lights up during recording.
15. **TIMER Light**  
This light glows when the DVD/VCR is in standby mode or off for a timer recording or during a Instant Recording Timer. It flashes if TIMER is pressed for a timer recording, but there is no tape in the DVD/VCR. It flashes when all timer recordings or Instant Recording Timer are finished.
16. **VCR OUTPUT Light (Green)**  
This light appears when the VCR output mode is selected. You can only watch tapes when the green VCR OUTPUT light is on. To make the green VCR OUTPUT light come on, VCR on the remote control or OUTPUT on the front panel.
17. **OUTPUT Button**  
Press to select DVD mode or VCR mode.  
● You can switch the output mode either by pressing OUTPUT on the front panel, or by pressing DVD or VCR on the remote control. However, **if you press OUTPUT on the front panel first, you need to reselect the corresponding mode by pressing DVD or VCR on the remote control.**
18. **DVD OUTPUT Light (Green)**  
This light appears when the DVD output mode is selected. You can only watch DVDs when the green DVD OUTPUT Light is on. To make the green DVD OUTPUT light come on, press DVD on the remote control or OUTPUT on the front panel.
19. **Display, Remote Sensor Window**
20. **PLAY Button (DVD)**  
Press to begin playback.
21. **STOP Button (DVD)**  
Stops operation of the disc.
22. **SURROUND Button**  
Press to activate the 3D sound.  
**SPEED Button**  
Press to select the VCR's recording speed (SP or SLP)
23. **O/I/(POWER/STANDBY) Button**  
Press to turn the power on and off.  
(As to the indication of the Operate switch, "I" shows ON and "O/I" shows electrical power stand-by.)
24. **Number Buttons**  
● **DVD mode**  
Press to directly select a Track (Audio CD) for playback.  
● **VCR mode**  
Press to select TV channels on the VCR.  
To select channels, enter channel numbers as a two-digit number for the quickest results. For example, to select channel 6, press 0 then 6.



25. **DISPLAY Button**
  - **DVD mode**  
Press to access or remove the display screen during DVD or Audio CD playback.
  - **VCR mode**  
Press to access or remove the VCR's on-screen status display.
26. **TV Button**  
Press to exclusively control the TV.
27. **DVD Button**  
Press to select DVD mode for the remote control.
  - You can switch the OUTPUT mode either by pressing OUTPUT on the front panel, or by pressing DVD or VCR on the remote control. However, **if you press OUTPUT on the front panel first, you need to re-select the corresponding mode by pressing DVD or VCR on the remote control.**
28. **◀◀ Button**
  - **DVD mode**  
Press to view the DVD picture in fast reverse motion or to reverse playback of an Audio CD.
  - **VCR mode**  
Press to rewind the tape, or to view the picture rapidly in reverse during the playback mode (Rewind Search).
29. **STOP Button**
  - **DVD mode**  
Press to stop the disc motion.
  - **VCR mode**  
Press to stop the tape motion.
30. **REC Button**  
Press once to start a recording.
31. **MENU Button**
  - **DVD mode**  
Press to display the menu of the Disc.
  - **VCR mode**  
Press to access the VCR menu.
32. **TOP MENU Button**  
Press to call up the title menu.
33. **SETUP Button**  
Press to enter the setup mode.
34. **ZOOM Button**  
Enlarges part of a DVD-reproduced image.
35. **MODE Button**  
Activates program playback or random playback mode when playing CDs or MP3. Sets Black level and virtual surround.
36. **SUBTITLE Button**  
Press to select the desired subtitle language.
- TIMER Button**  
Press to put the VCR into standby mode for a timer recording.
37. **ANGLE Button**  
Press to change the camera angle to see the sequence being played back from a different angle.
38. **REPEAT Button**  
Repeats playback of the current disc, title, chapter or track.
39. **A-B REPEAT Button**  
Repeats playback of a selected section.
40. **SEARCH MODE Button**
  - **DVD mode**  
Press to access or remove the Search display, which allows you to go directly to a specific Title/Chapter/Track/Time.
  - **VCR mode**  
Press to perform a Time Search or an Index Search.
41. **CLEAR/C.RESET Button**
  - **DVD mode**  
Press to reset the setting.
  - **VCR mode**  
Press to reset the counter. Press to exit from the MENU screen.
42. **RETURN Button**  
Returns to the previous operation.
43. **TV CH ▼/▲ Buttons**  
Press to exclusively control the TV channels.
- VOL ▼/▲ Buttons**  
Press to exclusively control the TV volume.
  - **DVD mode**
- ▼/▲/▶/◀ Buttons**  
Move the cursor and determines its position.
  - **VCR mode**
- ▼/▲ Buttons**  
Press to enter digits when setting program (For example: setting clock or timer program). Press to select the setting modes from the on screen menu.
  - ▶ **Button**  
When setting program (For example: setting clock or timer program), press to determine your selection and proceed to the next step you want to input. Press to determine the setting modes from the on screen menu. Press to add or delete channel numbers during channel preset.
  - ◀ **Button**  
Press to cancel a setting of timer program. Press to correct digits when setting program (For example: setting clock or timer program). Press to add or delete channel numbers during channel preset.
44. **ENTER Button**  
Press to accept a setting.
- VIDEO/TV Button**  
Press to select the external input mode or TV mode of the TV.
45. **TV POWER Button**  
To exclusively turn ON/OFF the TV.
46. **▶▶ Button**
  - **DVD mode**  
Press to fast forward the Disc. Press PAUSE/STEP, then press this button to begin slow motion playback. Press this button repeatedly to change the forward speed of slow motion.
  - **VCR mode**  
Press to rapidly advance the tape, or view the picture rapidly in forward during playback (Forward Search).
47. **PLAY Button**
  - **DVD mode**  
Press to begin playback.
  - **VCR mode**  
Press to begin playback.
48. **VCR Button**  
Press to select VCR mode for the remote control.
  - You can switch the OUTPUT mode either by pressing OUTPUT on the front panel, or by pressing DVD or VCR on the remote control. However, **if you press OUTPUT on the front panel first, you need to re-select the corresponding mode by pressing DVD or VCR on the remote control.**
49. **PAUSE/STEP Button**
  - **DVD mode**  
Press to pause Disc playback. Press repeatedly to advance the DVD picture step by step (or one frame at a time).
  - **VCR mode**  
While recording, press to temporarily stop the recording (pause). Press a second time to resume normal recording. You can not pause a Instant Recording Timer. Or, press during tape playback to freeze the picture. Press to advance the picture one frame at a time during still mode.
50. **SLOW Button**  
During tape playback, press to view the video tape in slow motion. Press again to resume normal playback. This button does not affect DVD playback.
51. **VCR/TV Button**  
Use to select VCR or TV position.  
This DVD/VCR does not have VCR/TV light. If noise appears on your TV when you turn on DVD/VCR(VCR mode), press this button.

● **VCR Position**

To view playback, to monitor video recordings or to watch TV using the VCR tuner.

● **TV Position**

To watch TV or to view one program while recording another.

**52. SKIP/CH Buttons**

● **DVD mode**

Press to skip Chapters or Tracks.

● **VCR mode**

Press to change TV channels on the VCR.

**Notes**

- To use the remote control to operate the DVD/VCR and its features, press DVD on the remote control before pressing other DVD. Verify that the green DVD OUTPUT Light is on.
- To use the remote control to operate the VCR and its features, press VCR on the remote control before pressing other VCR. Verify that the green VCR OUTPUT Light is on.

**53. OPEN/CLOSE Button**

Press to open or close the disc loading tray.

**EJECT Button**

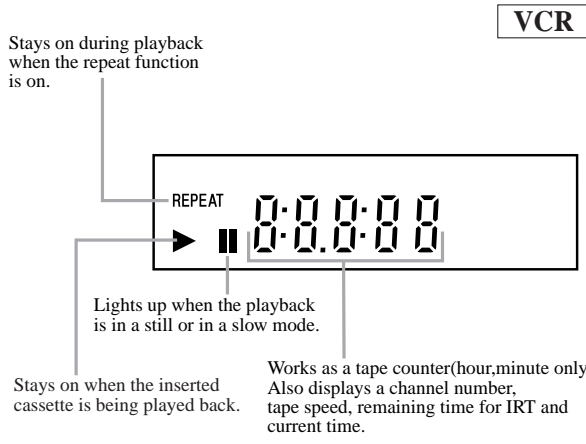
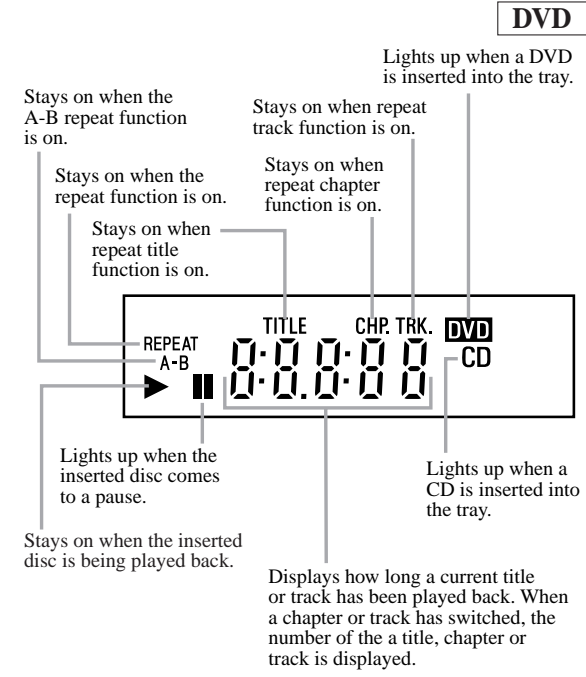
Press to eject the video cassette from the VCR.

**54. AUDIO Button**

Press to select a desired audio language or sound mode.

**Caution: Do not touch the inner pins of the jacks on the rear panel. Electrostatic discharge may cause permanent damage to the DVD/VCR.**

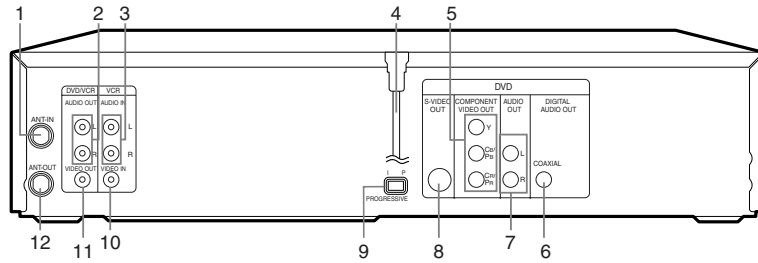
**DISPLAY**



**DISPLAYS DURING OPERATION**

	No disc inserted or playing DVD menu
	Tray open
	Tray closed
	Loading the Disc

## REAR VIEW



### 1. ANT-IN (Antenna In) Jack

Connect your antenna, Cable Box, or Direct Broadcast System.

### 2. DVD/VCR AUDIO OUT Jacks

Connect the supplied audio cables here and to the Audio In jacks of a television or other audio equipment.

### 3. AUDIO IN Jacks (VCR only)

Connect audio cables coming from the audio out jacks of a camcorder, another VCR, or an audio source here.

### 4. AC Power Cord

Connect to a standard AC outlet to supply power to the DVD/VCR.

### 5. COMPONENT VIDEO OUT Jacks (DVD only)

Connect optional component video cables here and to the component Video In jacks of a television.

### 6. COAXIAL Jack (DVD only)

Connect an optional coaxial digital audio cable here and to the Coaxial Digital Audio In jack of a decoder or audio receiver.

### 7. DVD AUDIO OUT Jacks (DVD only)

Connect the supplied audio cables here and to the Audio

In jacks of a television or other audio equipment (DVD only).

### 8. S-VIDEO OUT Jack (DVD only)

Connect an optional S-Video cable here and to the S-Video In jack of a television.

### 9. INTERLACE/PROGRESSIVE SCAN SELECTOR

to select interlace or progressive scanning.

### 10. VIDEO IN Jack (VCR only)

Connect a cable coming from the video out jack of a camcorder, another VCR, or an audio-visual source (laser disc player, video disc player, etc.) here.

### 11. DVD/VCR VIDEO OUT Jack

Connect the yellow video cable (supplied) here and to the TV's Video In jack.

If you select P(PROGRESSIVE) in INTERLACE/PROGRESSIVE SCAN SELECTOR, DVD video signal is not output to your TV.

### 12. ANT-OUT (Antenna Out) Jack

Use the supplied RF coaxial cable to connect this jack to the ANTENNA IN Jack on your TV.

## CAUTION:

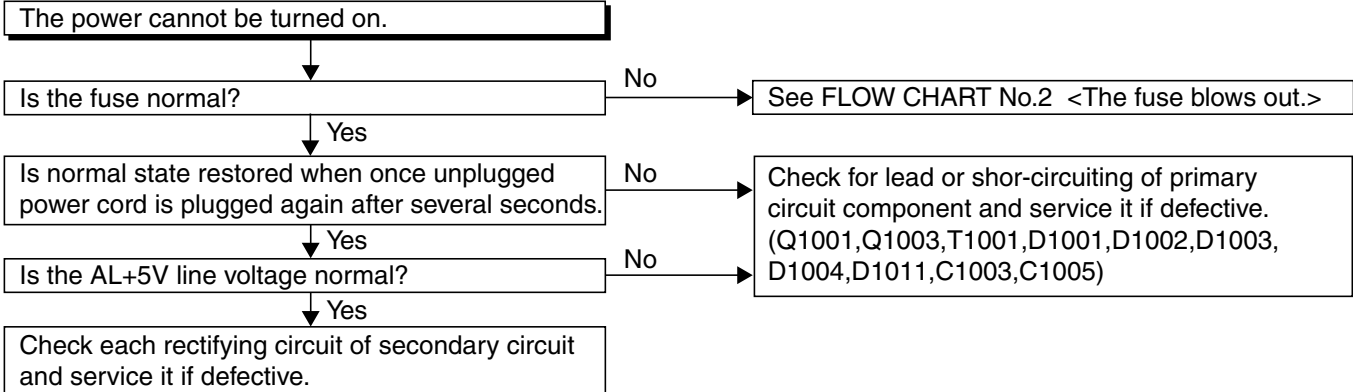
- Be sure to turn off the DVD/VCR and equipment to be connected before connecting.
- Read through the operation manual for the equipment to be connected.
- Be sure that the colors of the jacks and plugs match up when using VIDEO/AUDIO cables.
- Be sure to keep the DVD/VCR connection cables separate from the TV antenna cable when you install the DVD/VCR, because it may cause electrical interference when you are watching television programs.

### 3-1 TROUBLESHOOTING

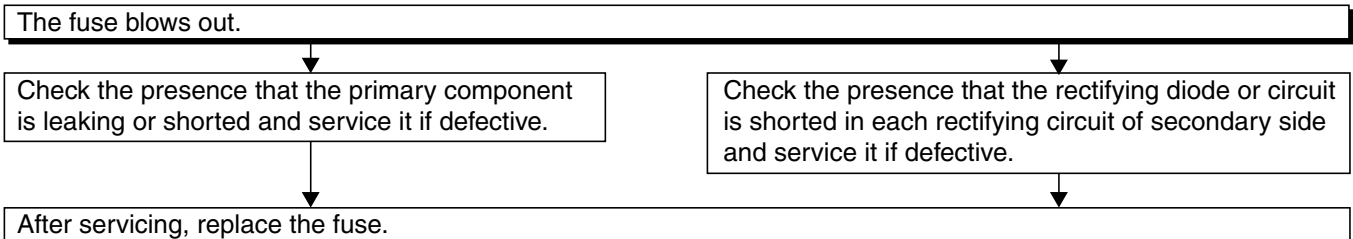
Troubleshooting is how to service for the specifying malfunction or poor parts.  
Detect malfunction or poor parts and service as the following charts.

#### 3-1-1 Power Supply Section

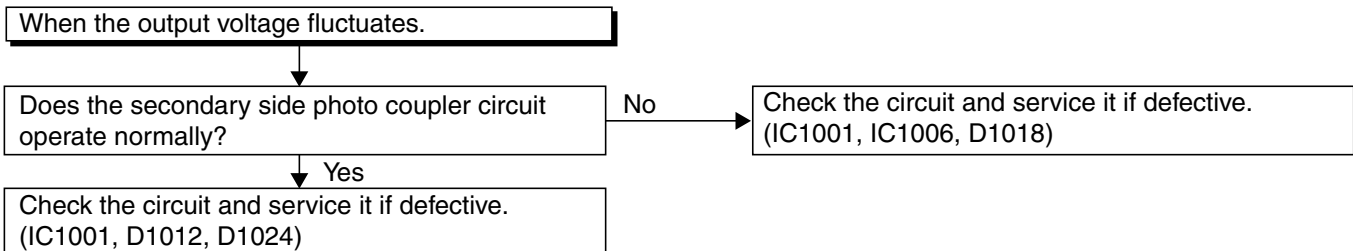
##### FLOW CHART NO.1



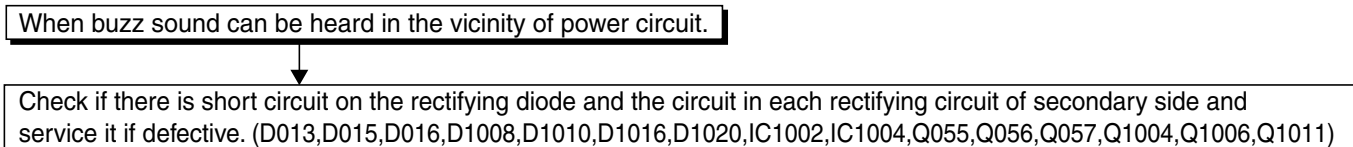
##### FLOW CHART NO.2



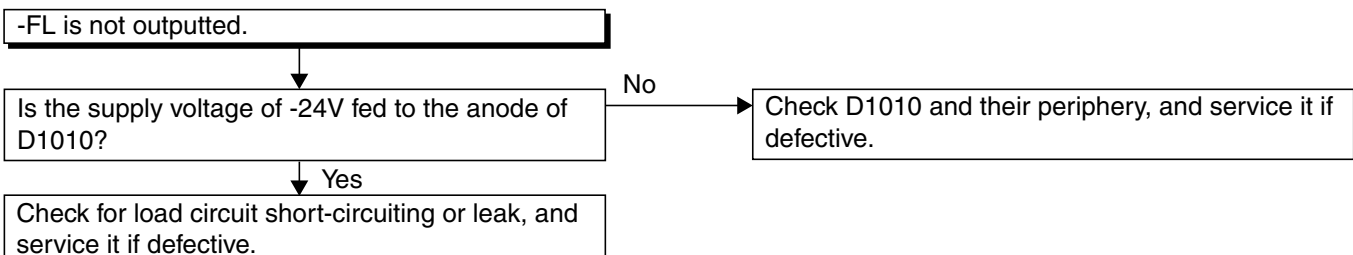
##### FLOW CHART NO.3



##### FLOW CHART NO.4



##### FLOW CHART NO.5



### FLOW CHART NO.6

P-ON+5V is not outputted. (P-ON+9V is outputted normally.)

Is 5V voltage supplied to the collector of Q056?

No

Check D016, D018, C020, C021, and their periphery, and service it if defective.

Yes

Is the "H" pulse inputted into the base of Q056?

No

Check Q056, R057 and their periphery, and service it if defective.

Yes

Replace Q056.

### FLOW CHART NO.7

EV+3.3V is not outputted. (P-ON+5V is outputted normally.)

Is 5V voltage supplied to Pin(1) of IC1004?

No

Check D1008, C1007, C1038 and their periphery, and service it if defective.

Yes

Replace IC1004.

### FLOW CHART NO.8

P-ON+12V is not outputted.

Is 12V voltage supplied to the emitter of Q1006?

No

Check D1015, D1019, C018 and their periphery, and service it if defective.

Yes

Is the "L" pulse (approximately 0V) outputted to the collector of Q1005?

No

Check Q1005 and PWRCON line, and service it if defective.

Yes

Replace Q1006.

### FLOW CHART NO.9

P-ON+3.3V is not outputted. (EV+3.3V is outputted normally.)

Is the "H" pulse (approximately 5V) inputted into the base of Q1011?

No

See FLOW CHART NO.8. <P-ON+12V is not outputted. >

Yes

Replace Q1011.

### FLOW CHART NO.10

EV 1.5V is not outputted.

Is approximately 2.35V voltage supplied to Pin(1) of IC1002?

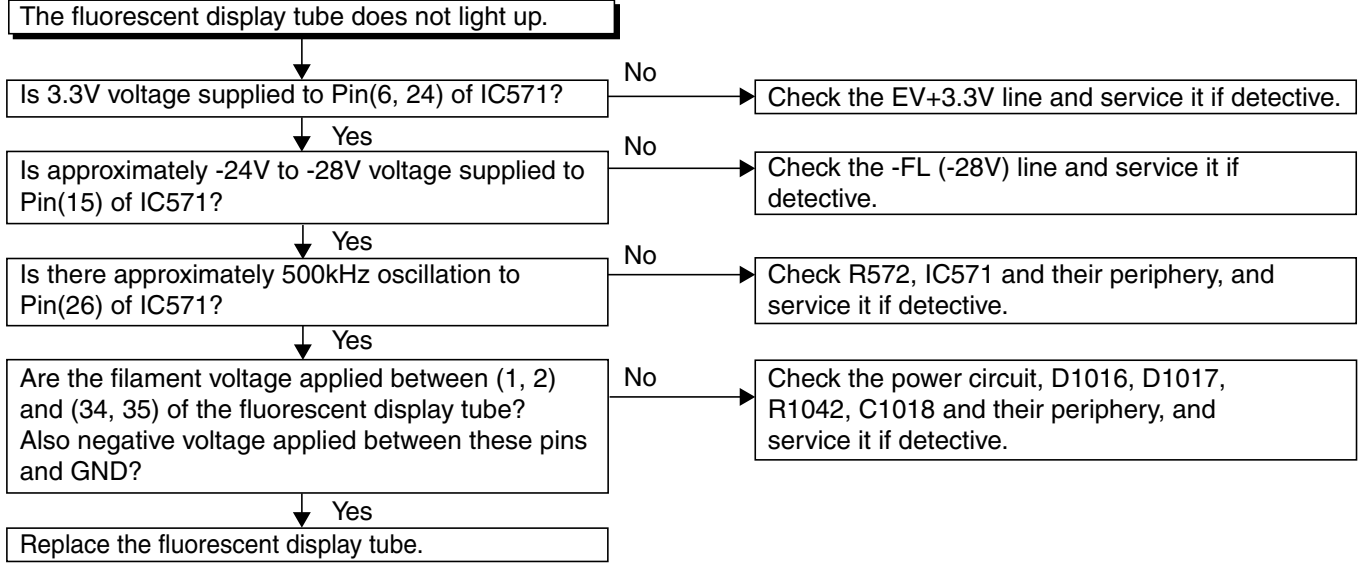
No

Check D1020, C1014, C1015, and their periphery, and service it if defective.

Yes

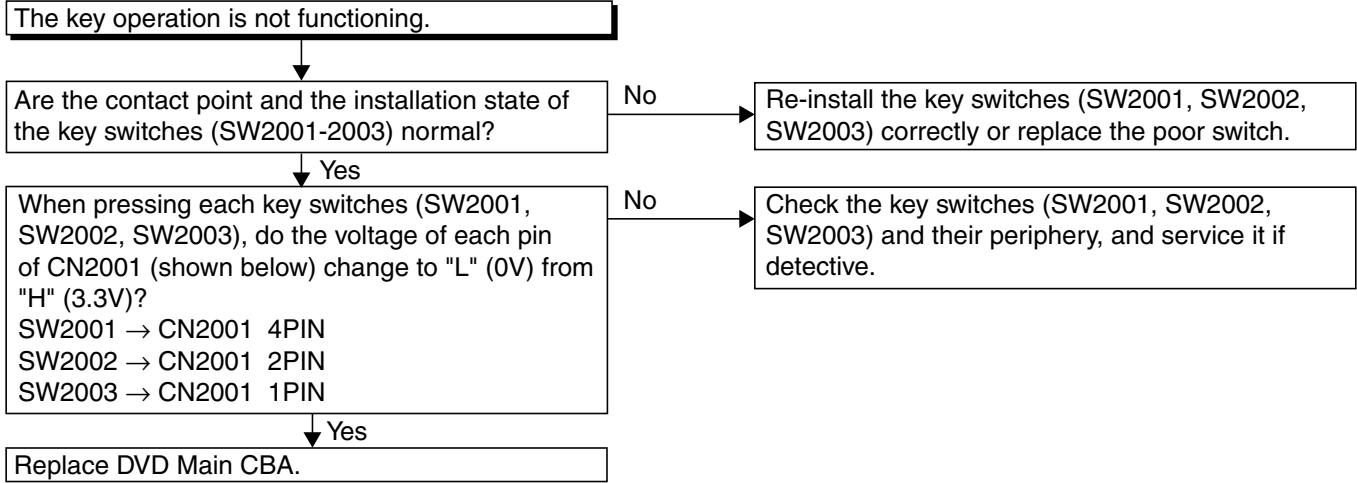
Replace IC1002.

### FLOW CHART NO.11

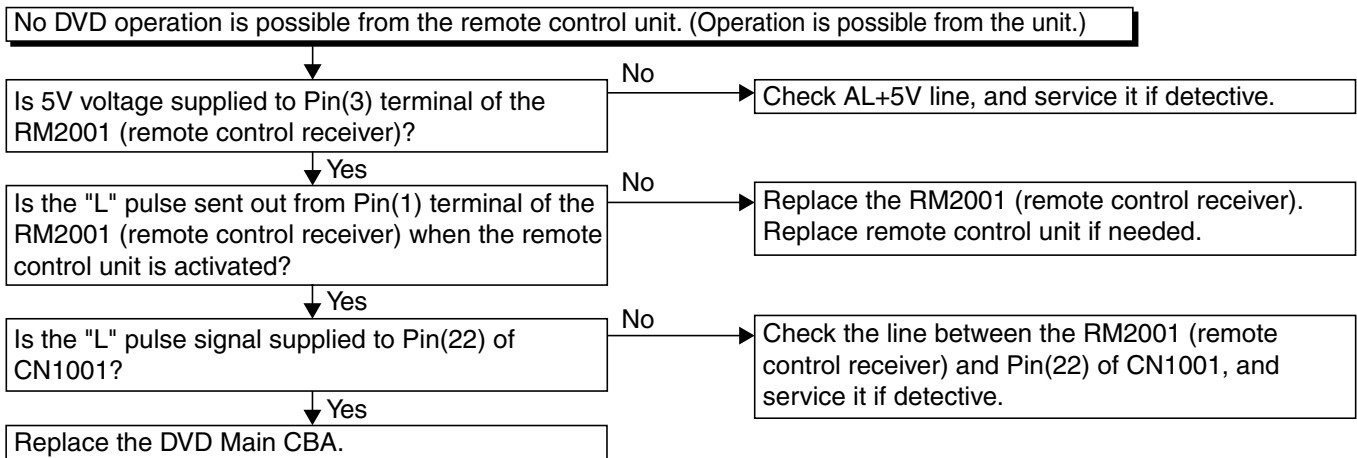


### 3-1-2 DVD Section

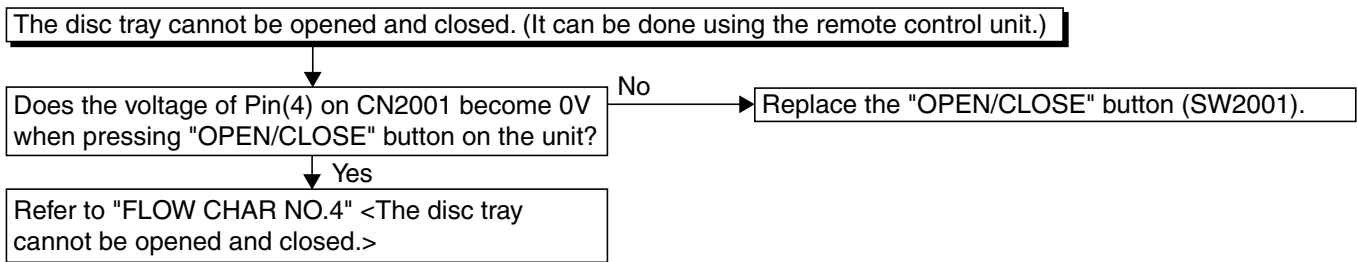
#### FLOW CHART NO.1



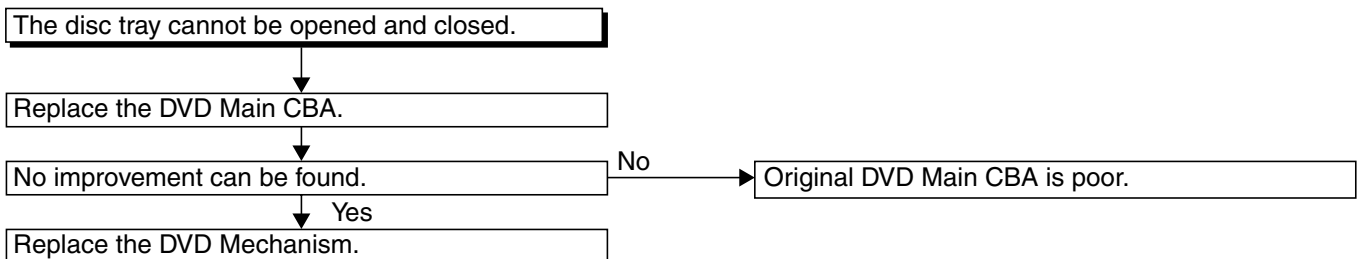
#### FLOW CHART NO.2



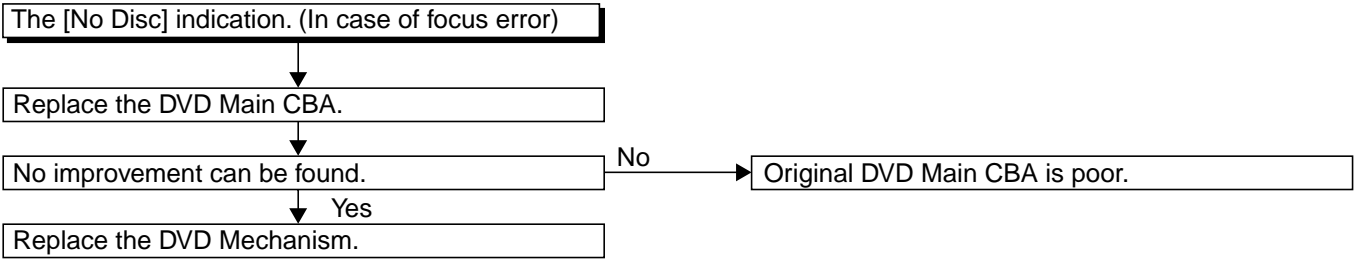
#### FLOW CHART NO.3



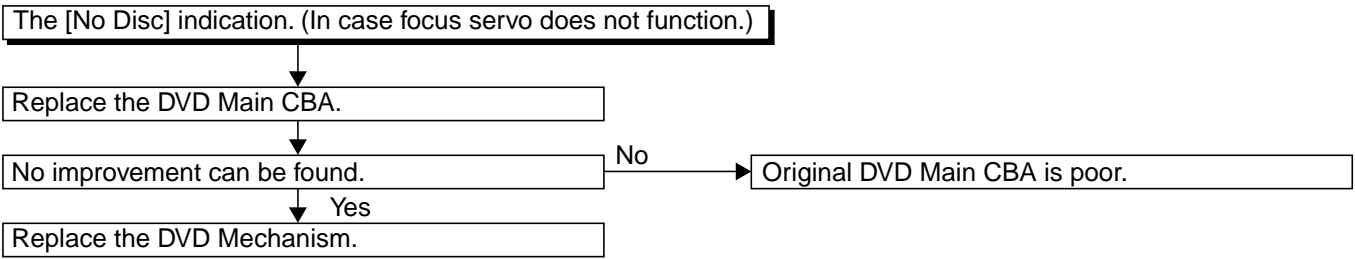
#### FLOW CHART NO.4



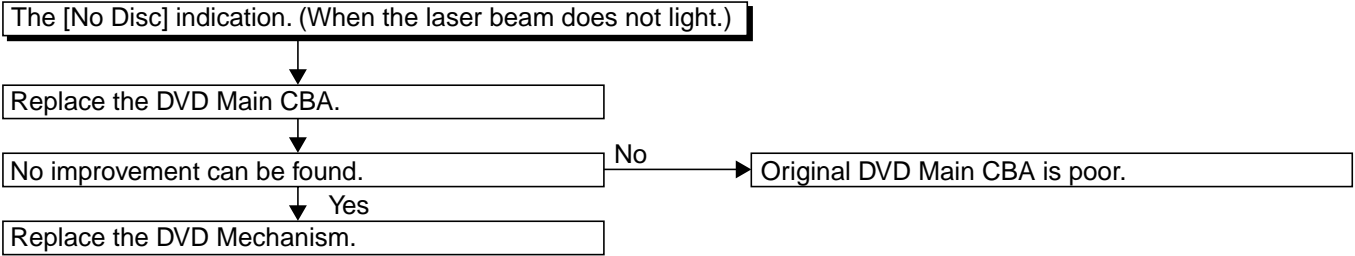
**FLOW CHART NO.5**



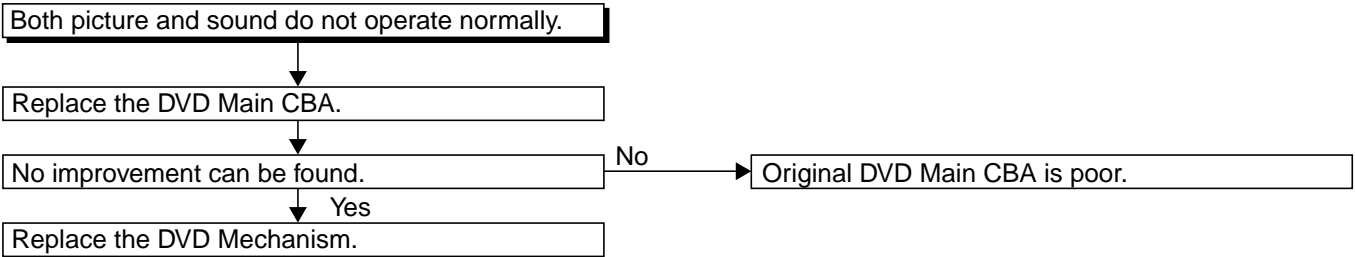
**FLOW CHART NO.6**



**FLOW CHART NO.7**

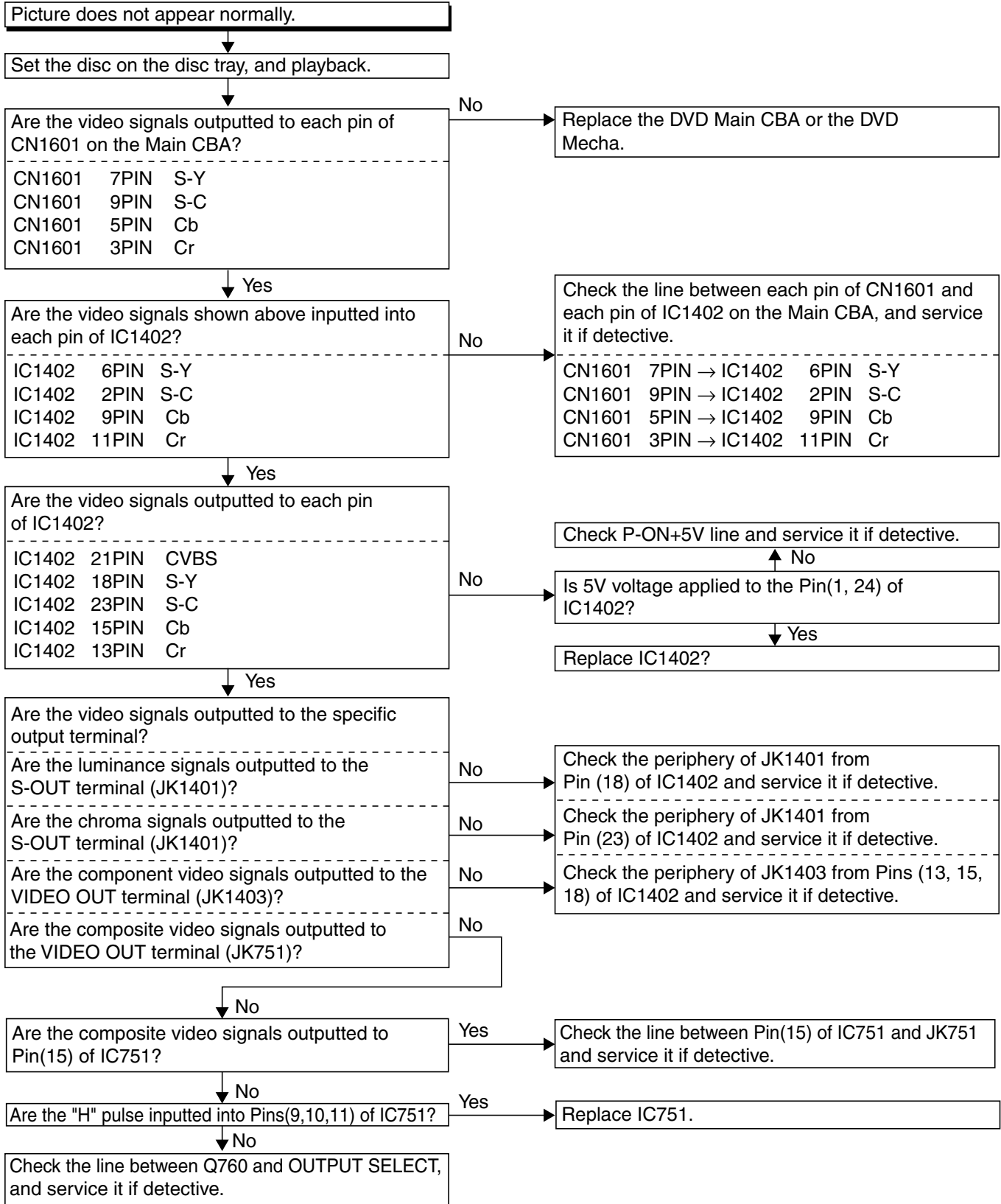


**FLOW CHART NO.8**

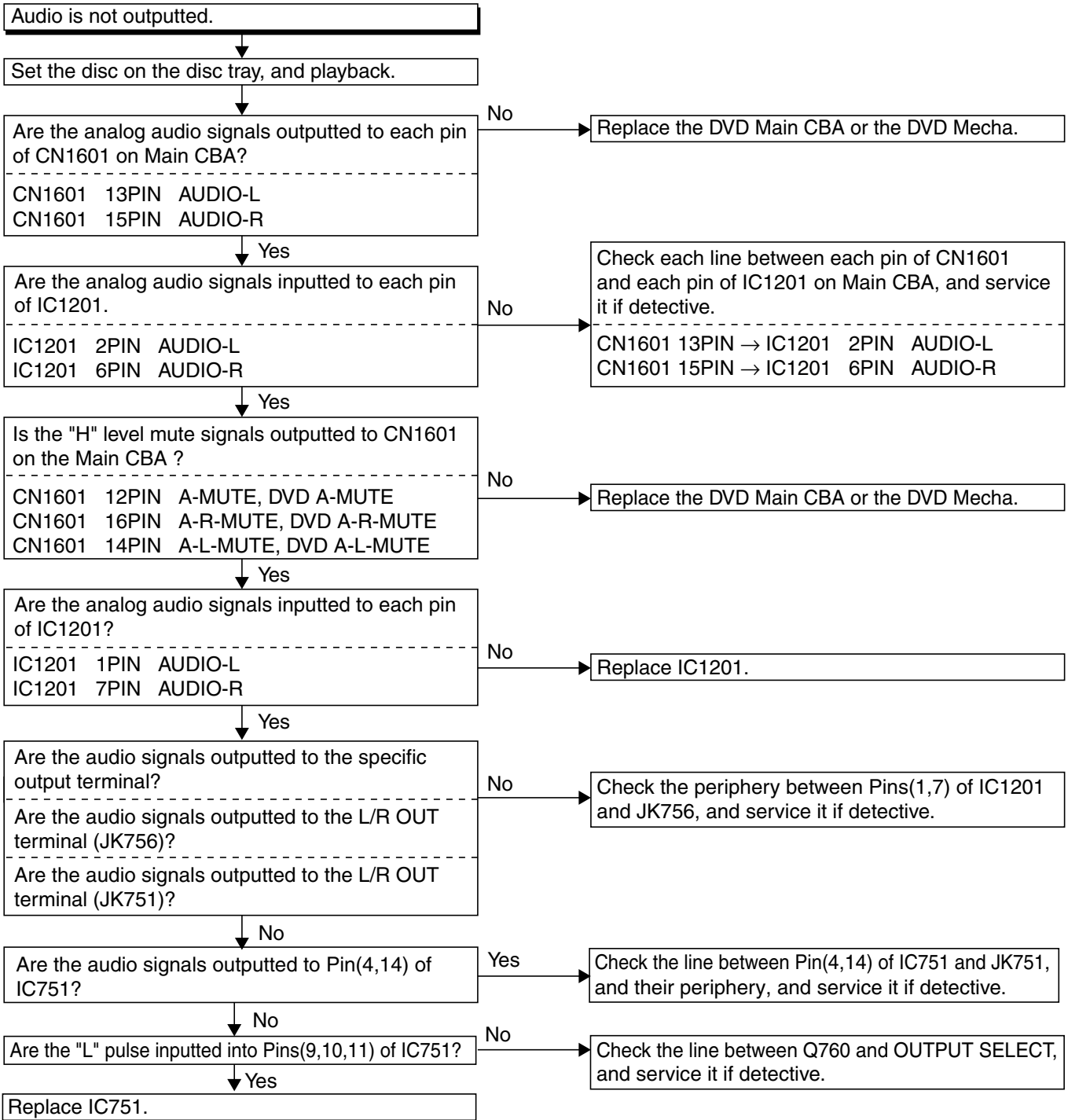




**FLOW CHART NO.9**

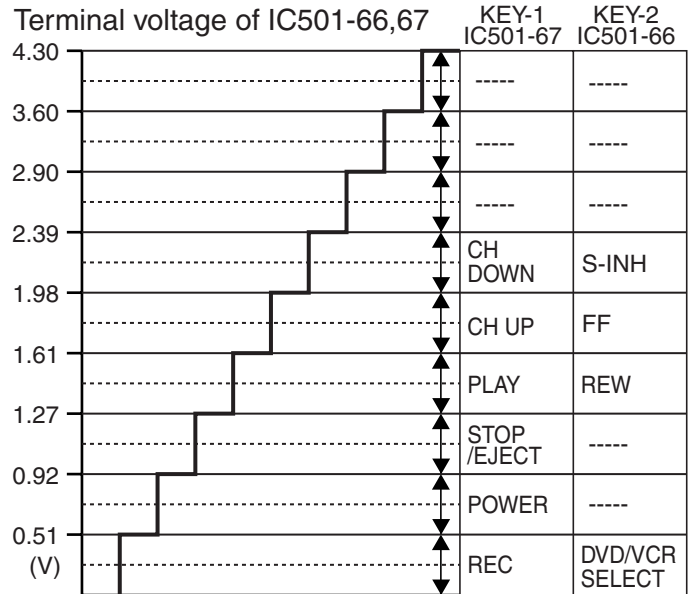
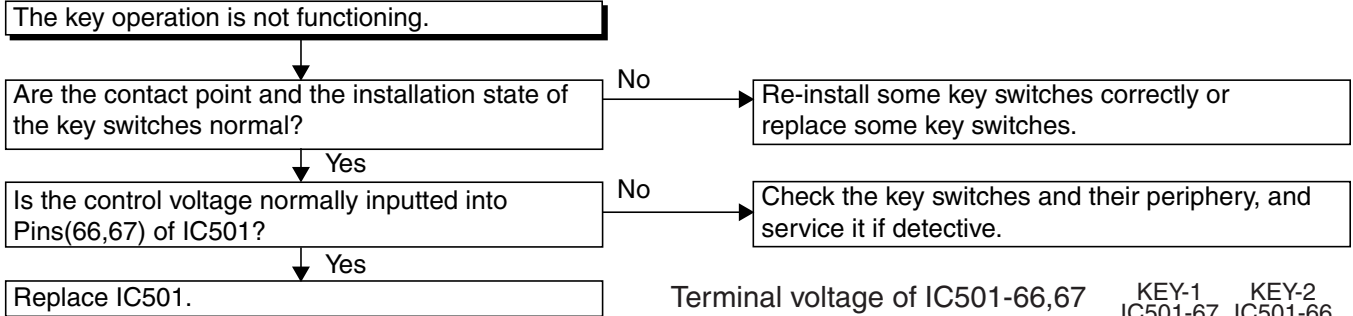


**FLOW CHART NO.10**

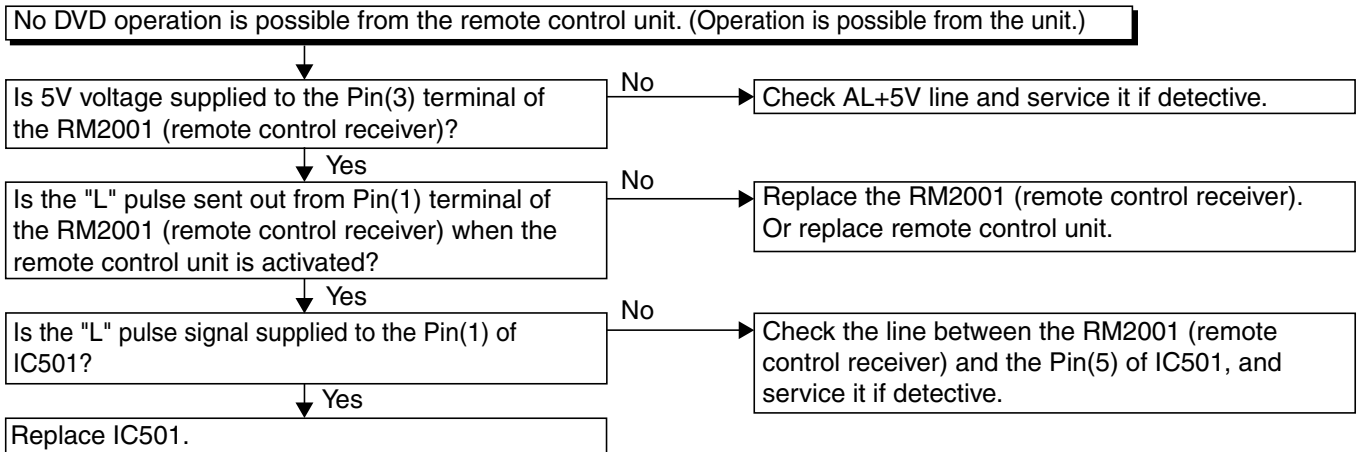


### 3-1-3 VCR Section

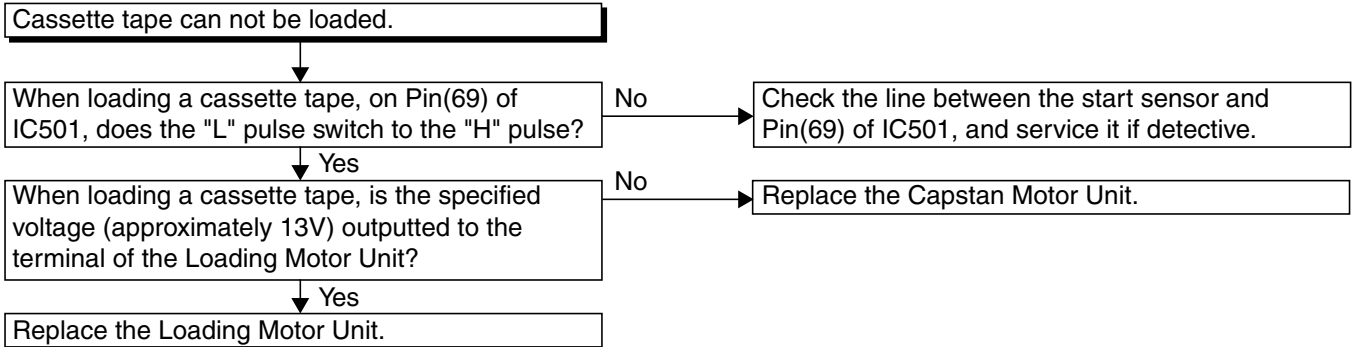
#### FLOW CHART NO.1



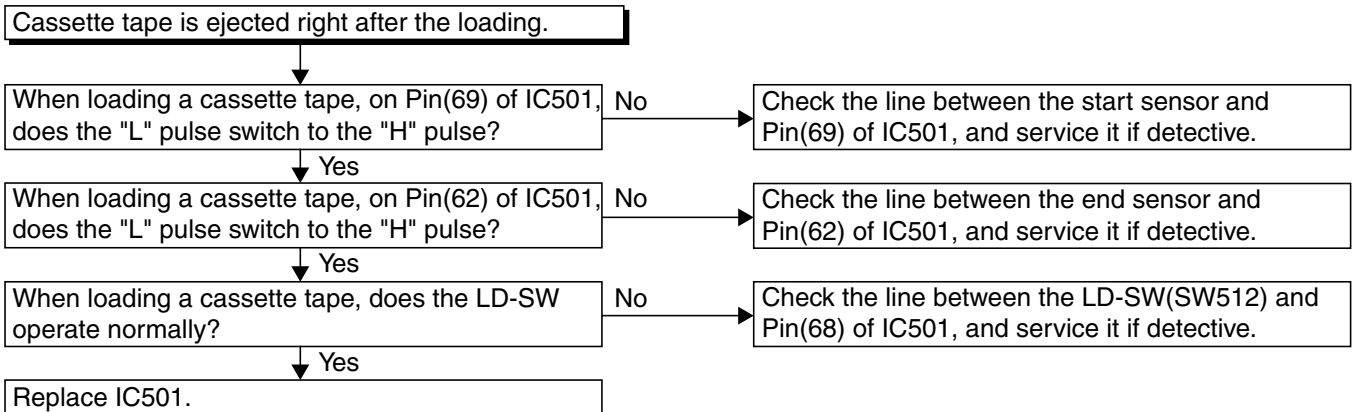
#### FLOW CHART NO.2



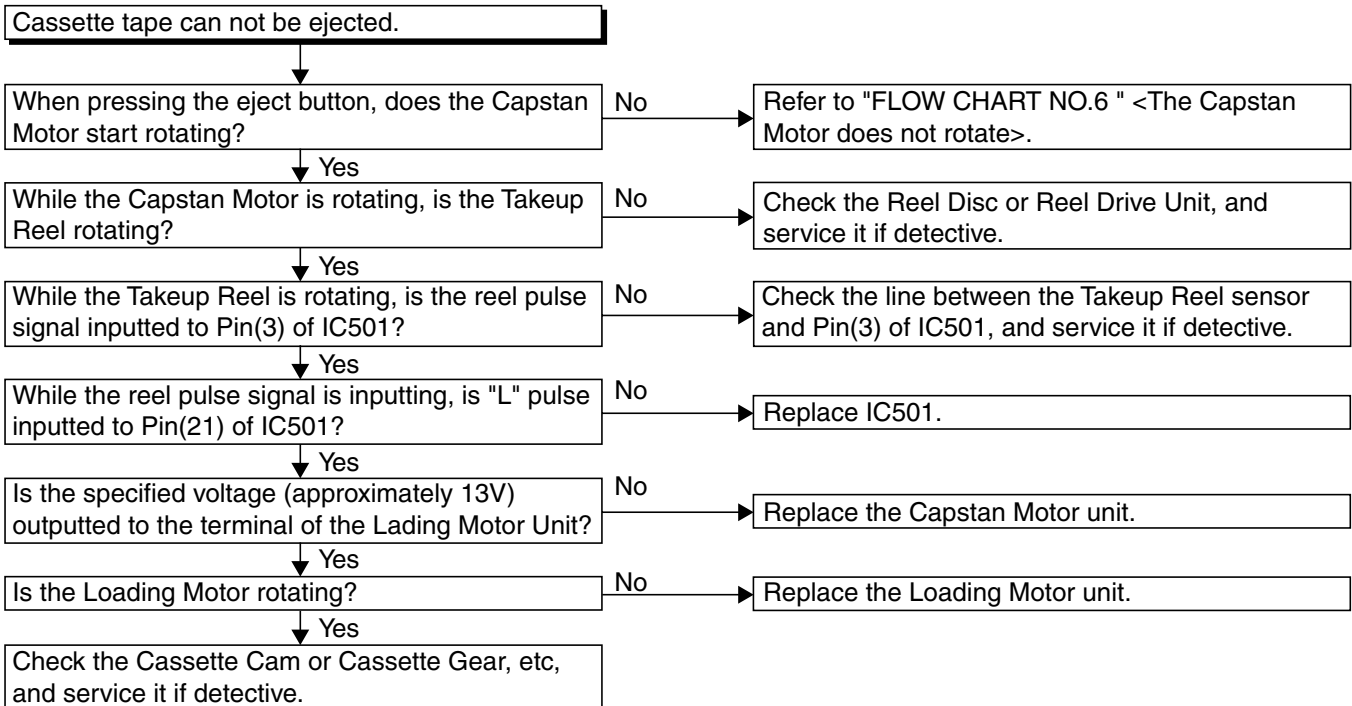
### FLOW CHART NO.3



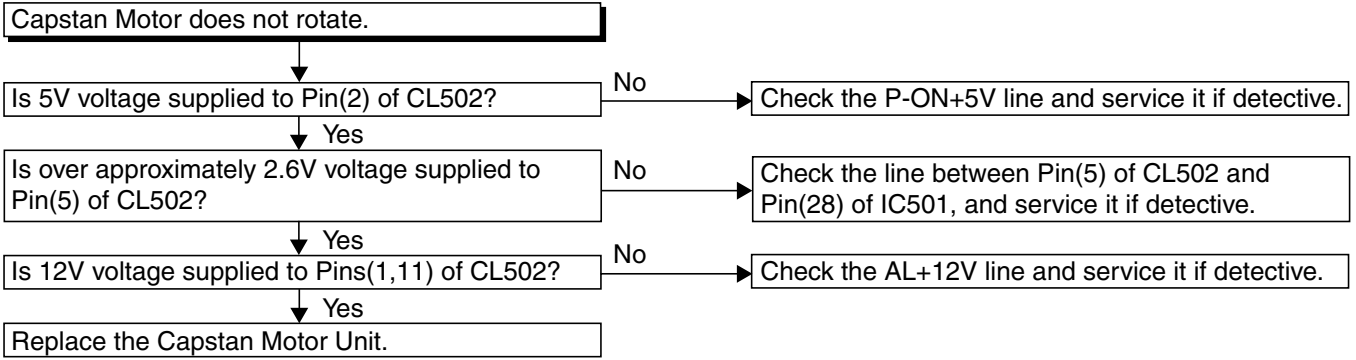
### FLOW CHART NO.4



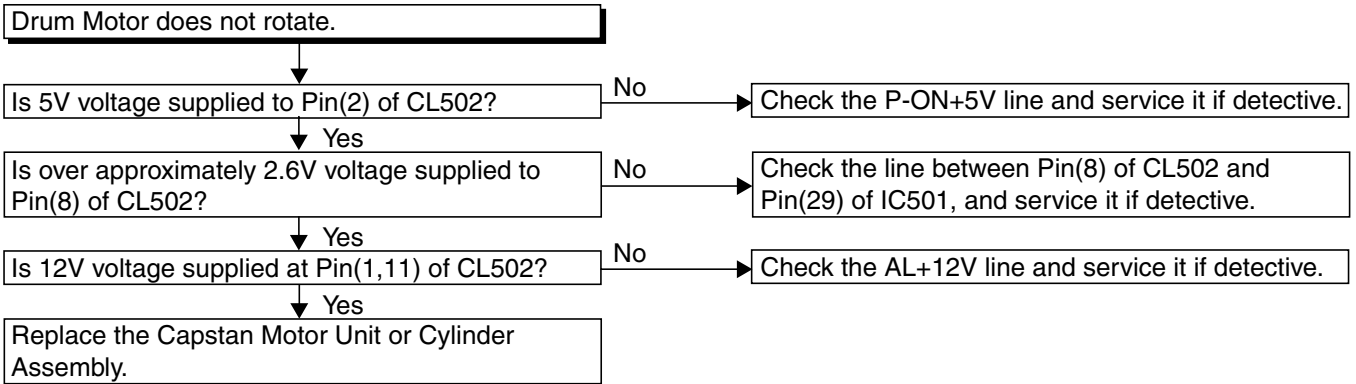
### FLOW CHART NO.5



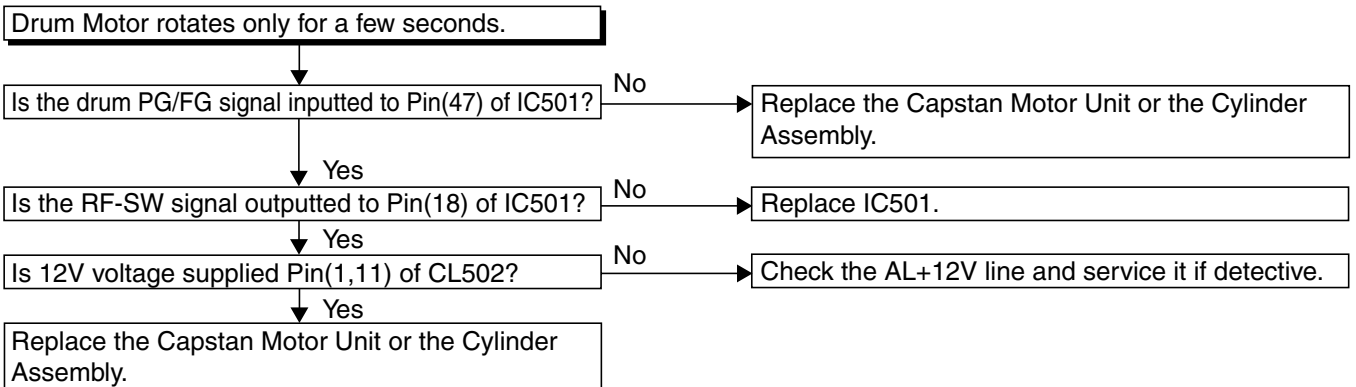
**FLOW CHART NO.6**



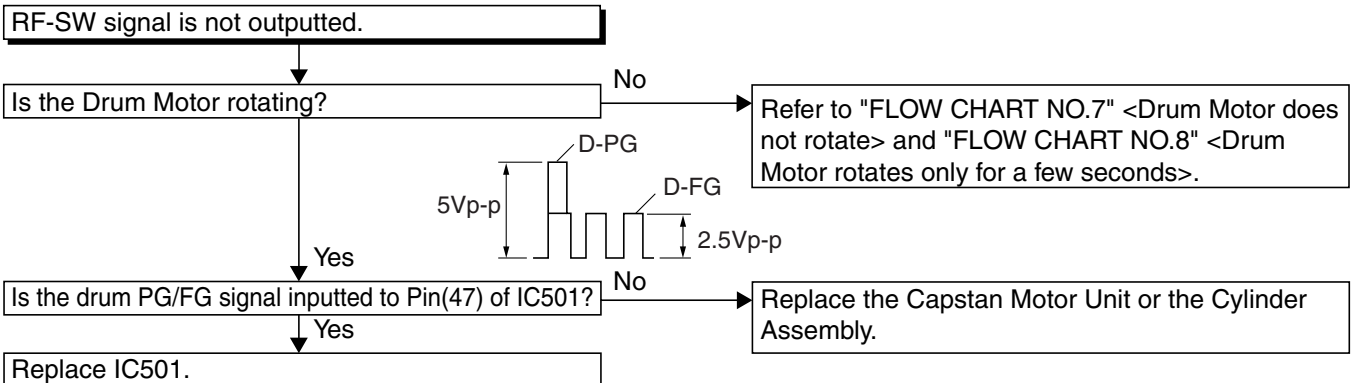
**FLOW CHART NO.7**



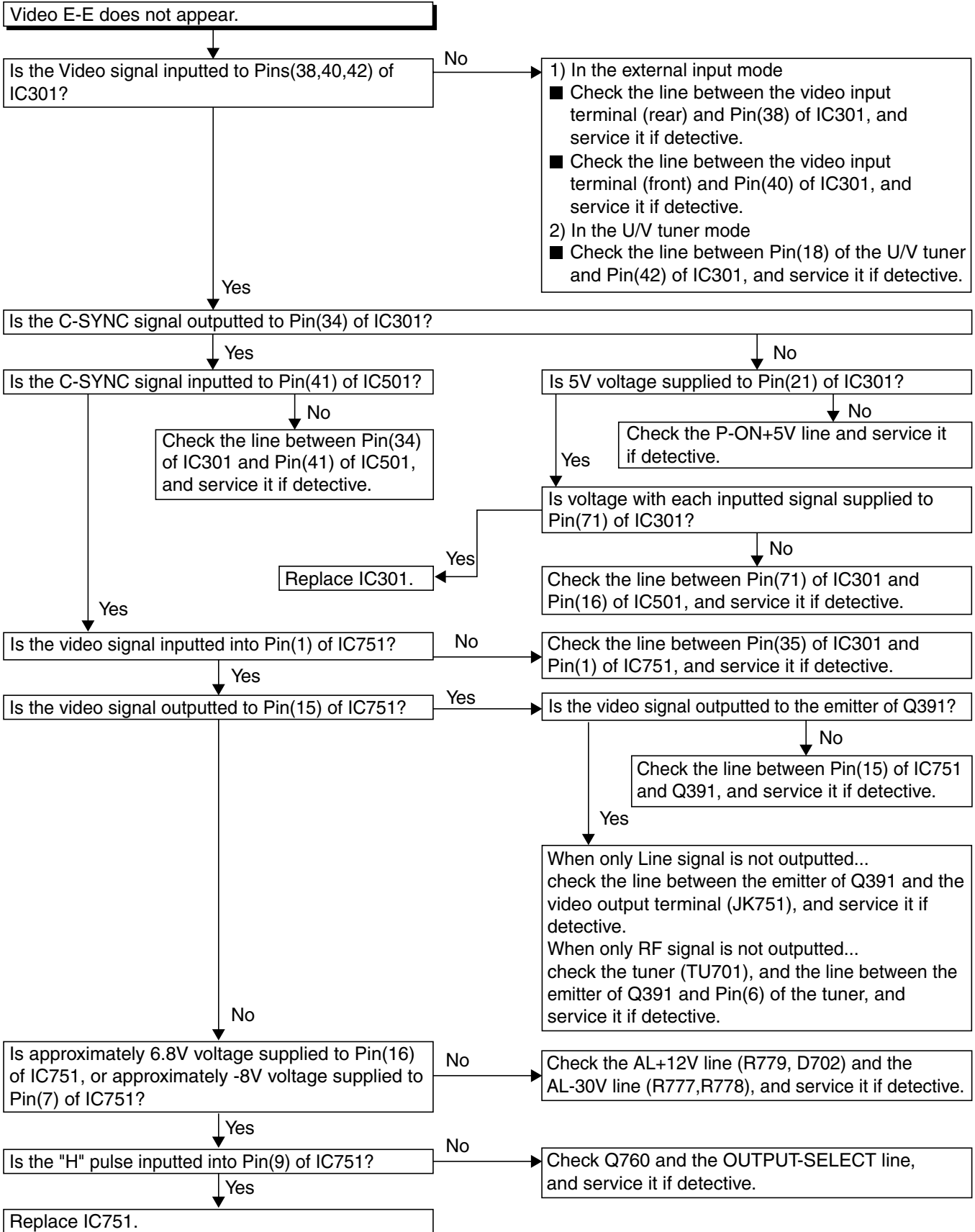
**FLOW CHART NO.8**



**FLOW CHART NO.9**



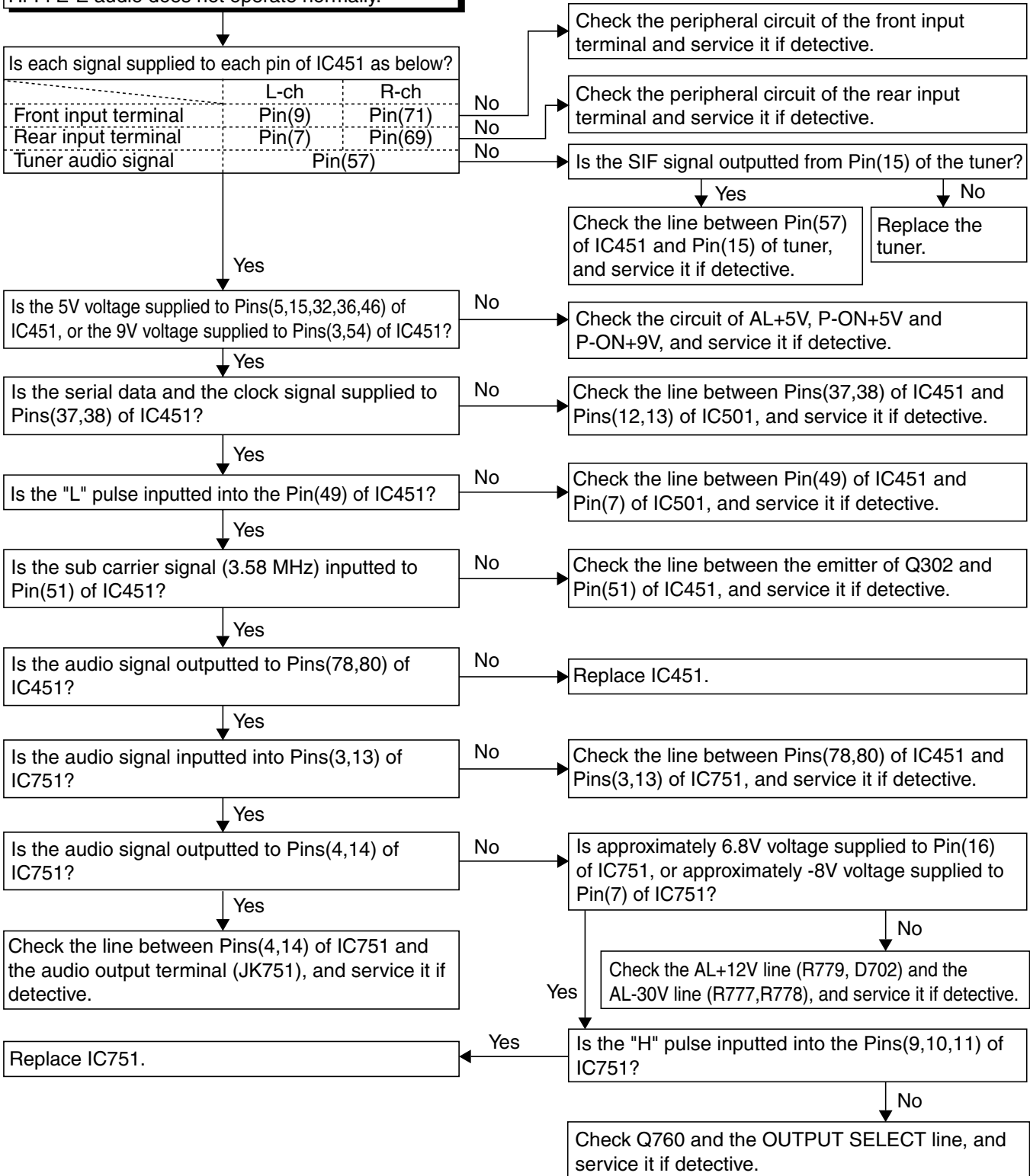
**FLOW CHART NO.10**



**FLOW CHART NO.11**

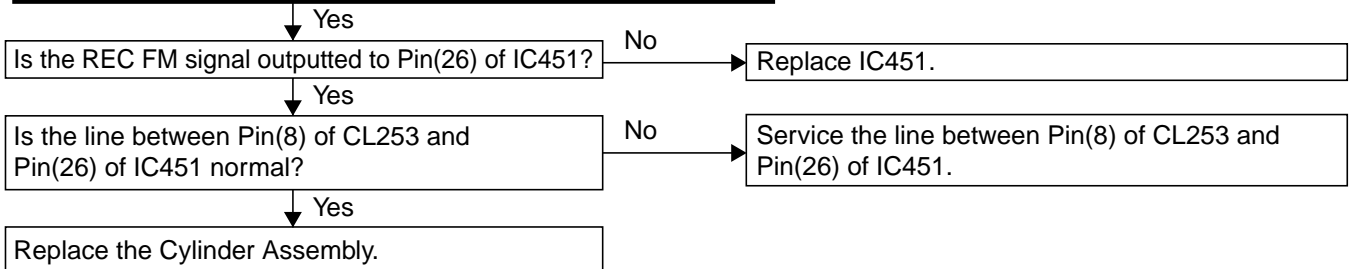
Hi-Fi E-E audio does not operate normally.

Is each signal supplied to each pin of IC451 as below?		
	L-ch	R-ch
Front input terminal	Pin(9)	Pin(71)
Rear input terminal	Pin(7)	Pin(69)
Tuner audio signal	Pin(57)	



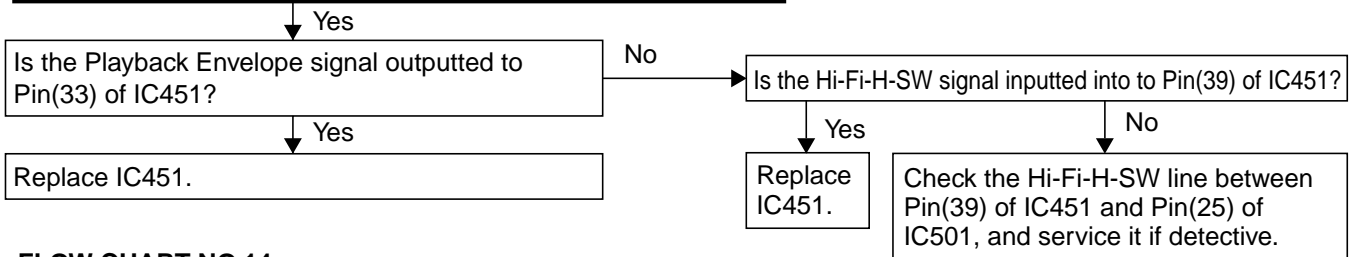
### FLOW CHART NO.12

Hi-Fi audio can not be recorded normally. (E-E mode is normal.)



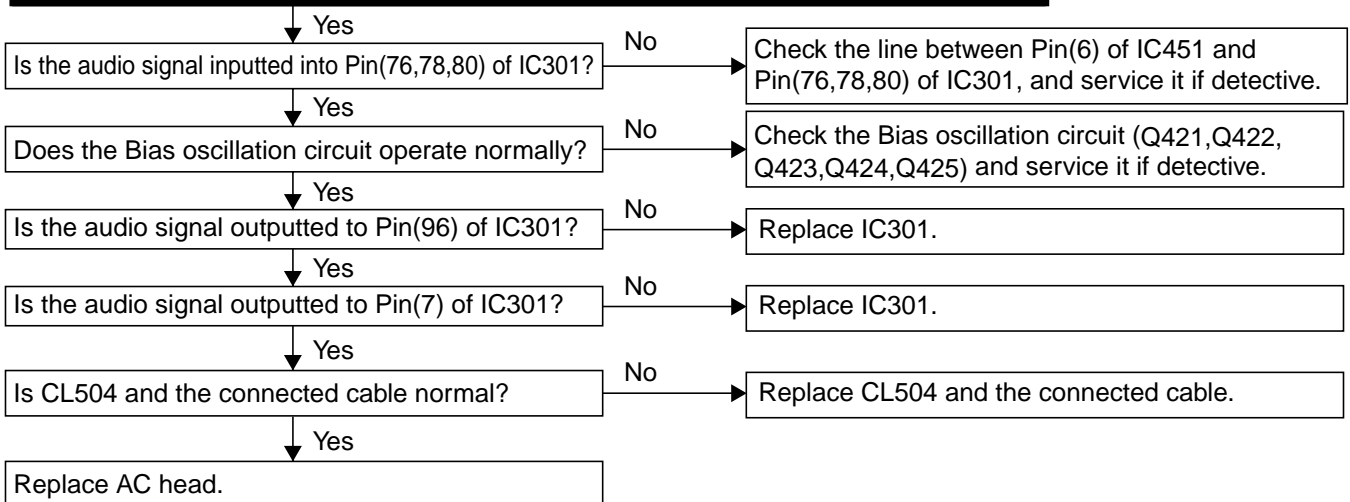
### FLOW CHART NO.13

Hi-Fi audio can not be playbacked normally. (Hi-Fi E-E mode is normal.)



### FLOW CHART NO.14

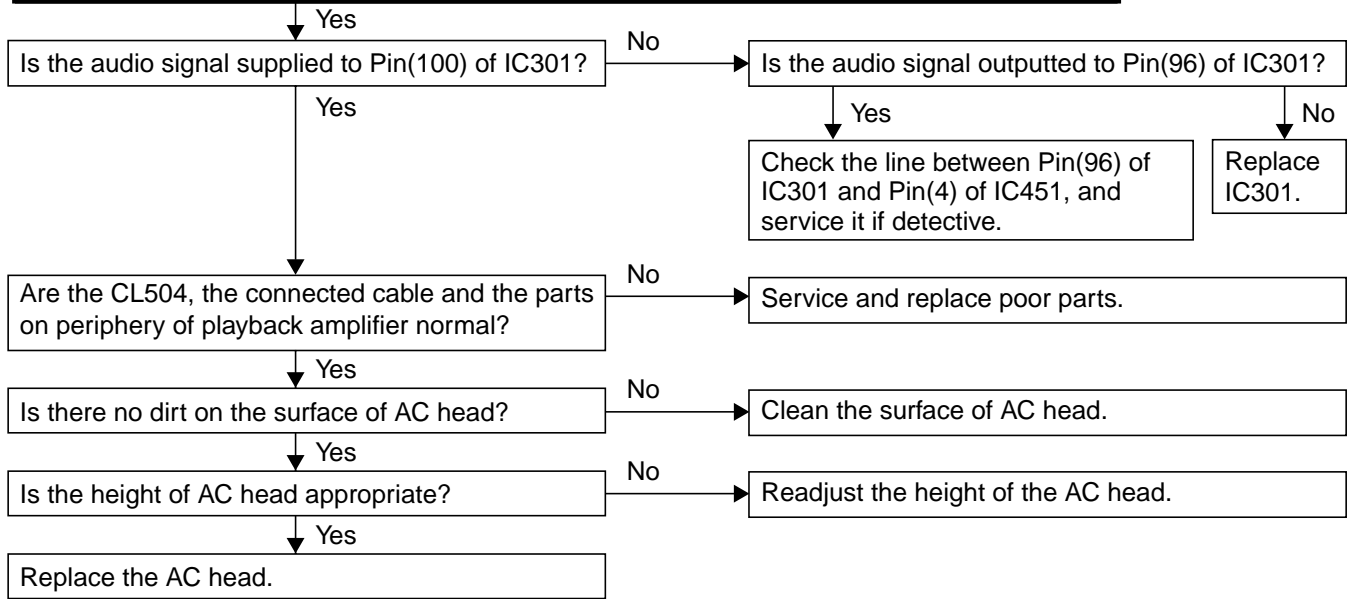
Hi-Fi audio can not be recorded normally in the linear audio mode. (E-E mode is normal.)





**FLOW CHART NO.15**

Hi-Fi audio can not be playbacked normally in the linear audio mode. (E-E mode is normal.)



# 3-2 FIRMWARE RENEWAL MODE

## 3-2-1 How to Update the Firmware Version

1. Turn the power on and remove the disc on the tray.
2. To put the DVD player into version up mode, press [9], [8], [7], [6], and [SEARCH MODE] buttons on the remote control unit in that order. The tray will open automatically.

Fig. a appears on the screen and Fig. b appears on the VFD.

The DVD player can also enter the version up mode with the tray open. In this case, Fig. a will be shown on the screen while the tray is open.

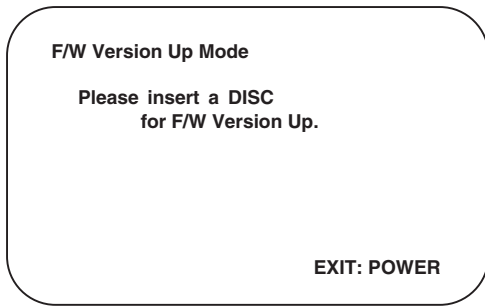


Fig. a Version Up Mode Screen

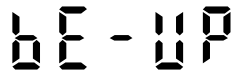


Fig. b VFD in Version Up Mode

3. Load the disc for version up.
4. The DVD player enters the F/W version up mode automatically. Fig. c appears on the screen and Fig. d appears on the VFD.

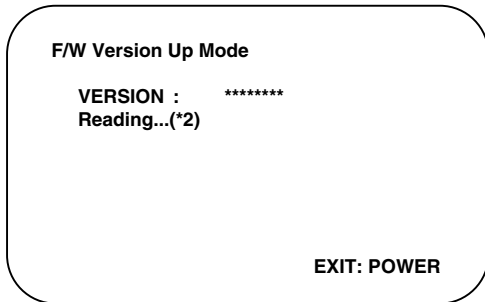


Fig. c Programming Mode Screen



Fig. d VFD in Programming Mode (Example)

The appearance shown in (\*2) of Fig. c is described as follows:

No.	Appearance	State
1	Reading...	Sending files into the memory
2	Erasing...	Erasing previous version data
3	Programming...	Writing new version data

5. After programming is finished, the tray opens automatically. Fig. e appears on the screen and the checksum in (\*3) of Fig. e appears on the VFD. (Fig. f)

At this time, no buttons are available.

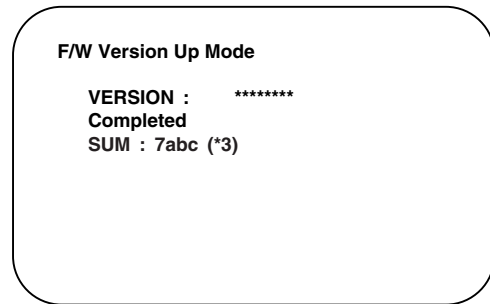


Fig. e Completed Program Mode Screen



Fig. f VFD upon Finishing the Programming Mode (Example)

6. Unplug the AC cord from the AC outlet. Then plug it again.
7. Turn the power on by pressing the power button and the tray will close.
8. Press [1], [2], [3], [4], and [DISPLAY] buttons on the remote control unit in that order. Fig. g appears on the screen.

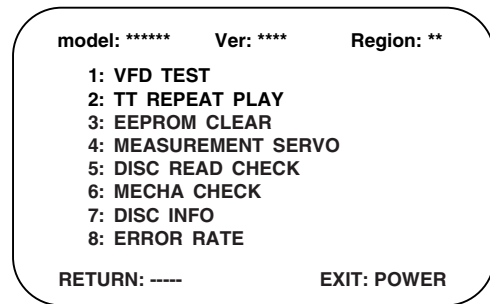


Fig. g

9. Press [3] button on the remote control unit. Fig. h appears on the screen.

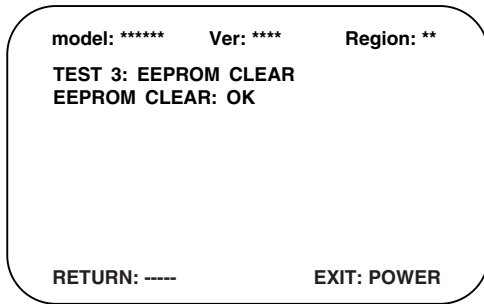


Fig. h

10. To finish this mode, press [POWER] button.

### 3-2-2 How to Verify the Firmware Version

1. After making sure that no disc is in unit, turn the power on.
2. Press [1], [2], [3], [4], and [DISPLAY] buttons on the remote control unit in that order. The B/E version appears on the VFD, and the F/E and B/E versions appear on TV screen.
3. Turn the power off to reset the unit.

**Note:**

If the firmware has been changed, etc., we will use Service News, etc. to report on how to obtain new firmware data and create an upgraded disc.

## 3-3 STANDARD MAINTENANCE

### 3-3-1 Service Schedule of Components

h: Hours ○: Check ●: Change

Deck		Periodic Service Schedule			
Ref.No.	Part Name	1,000 h	2,000 h	3,000 h	4,000 h
B2	Cylinder Assembly	○	●	○	●
B3	Loading Motor Assembly			●	
B8	Pulley Assembly		●		●
B587	Tension Lever Assembly		●		●
B31	AC Head Assembly			●	
B573,B574	Reel (SP)(D2), Reel (TU)(D2)			●	
B37	Capstan Motor		●		●
B52	Cap Belt		●		●
*B73	FE Head			●	
B133,B134	Idler Gear, Idler Arm		●		●
B410	Pinch Arm Assembly		●		●
B414	M Brake (SP) Assembly		●		●
B416	M Brake (TU) Assembly		●		●
B525	LDG Belt		●		●
B569 (2 head only)	Cam Holder (F)		●		●
B593 (4 head, 4 head HiFi only)	Cam Holder (F) Assembly		●		●

#### Notes:

1. Clean all parts for the tape transport (Upper Drum with Video Head / Pinch Roller / Audio Control Head / Full Erase Head) using 90% Isopropyl Alcohol.
  2. After cleaning the parts, do all DECK ADJUSTMENTS.
  3. For the reference numbers listed above, refer to Deck Exploded Views.
- \* B73 ----- Recording Model only

## 3-3-2 Cleaning

### Cleaning of Video Head

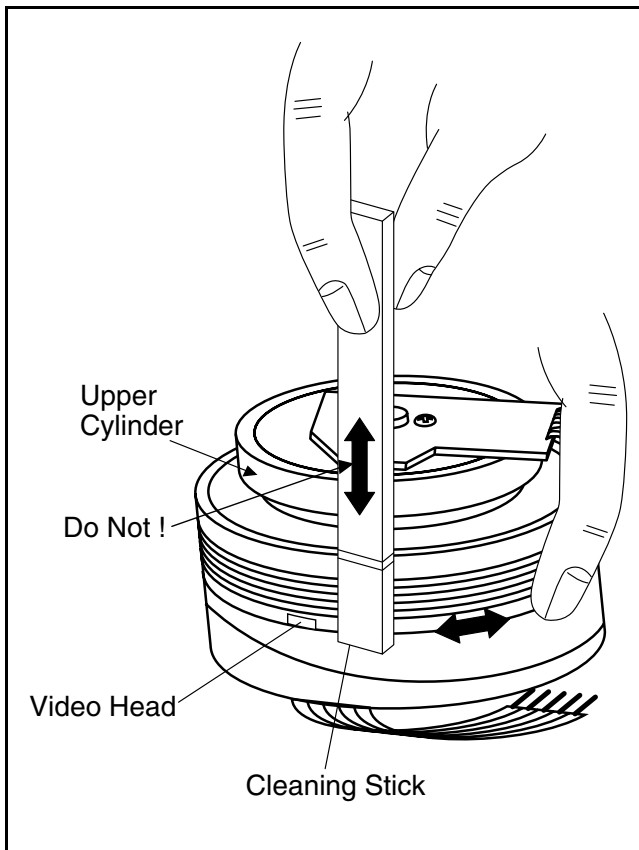
Clean the head with a head cleaning stick or chamois cloth.

#### Procedure

1. Remove the top cabinet.
2. Put on a glove (thin type) to avoid touching the upper and lower drum with your bare hand.
3. Put a few drops of 90% Isopropyl alcohol on the head cleaning stick or on the chamois cloth and, by slightly pressing it against the head tip, turn the upper drum to the right and to the left.

#### Notes:

1. The video head surface is made of very hard material, but since it is very thin, avoid cleaning it vertically.
2. Wait for the cleaned part to dry thoroughly before operating the unit.
3. Do not reuse a stained head cleaning stick or a stained chamois cloth.



### Cleaning of Audio Control Head

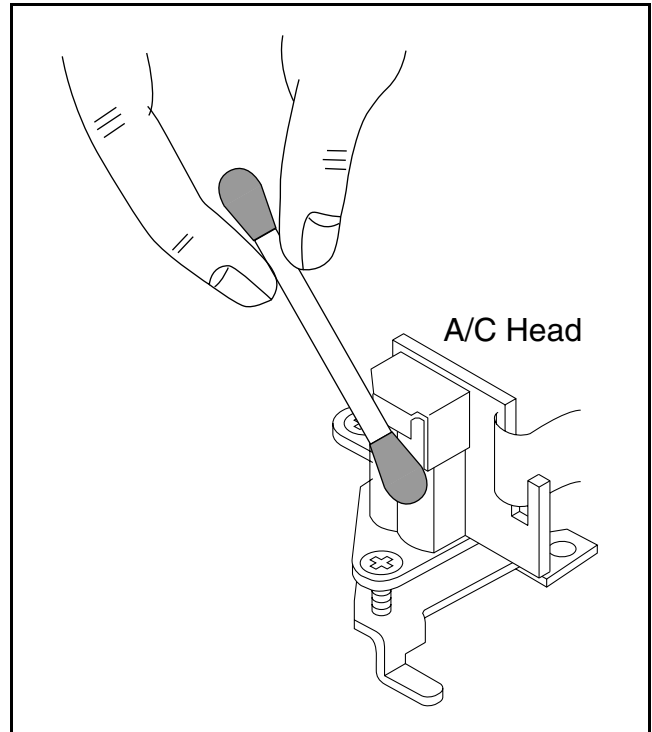
Clean the head with a cotton swab.

#### Procedure

1. Remove the top cabinet.
2. Dip the cotton swab in 90% Isopropyl alcohol and clean the audio control head. Be careful not to damage the upper drum and other tape running parts.

#### Notes:

1. Avoid cleaning the audio control head vertically.
2. Wait for the cleaned part to dry thoroughly before operating the unit or damage may occur.



## 4-1 PREPARATION FOR SERVICING

### 4-1-1 How to Enter the Service Mode

#### About Optical Sensors

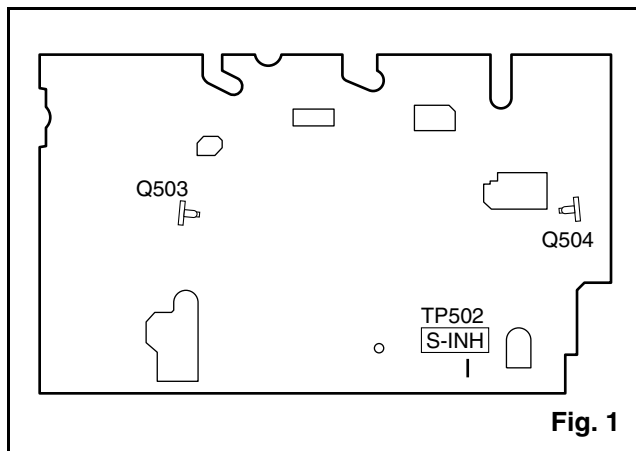
##### **Caution:**

An optical sensor system is used for the Tape Start and End Sensors on this equipment. Carefully read and follow the instructions below. Otherwise the unit may operate erratically.

##### **What to do for preparation**

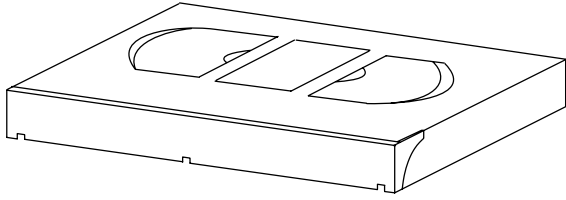
Insert a tape into the Deck Mechanism Assembly and press the PLAY button. The tape will be loaded into the Deck Mechanism Assembly. Make sure the power is on, TP502 (SENSOR INHIBITION) to GND. This will stop the function of Tape Start Sensor, Tape End Sensor and Reel Sensors. (If these TPs are connected before plugging in the unit, the function of the sensors will stay valid.) See Fig. 1.

**Note:** Because the Tape End Sensors are inactive, do not run a tape all the way to the start or the end of the tape to avoid tape damage.

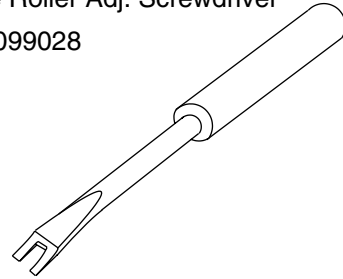


## 4-2 FIXTURE AND TAPE FOR ADJUSTMENT

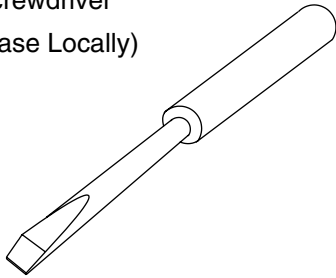
1. Alignment Tape  
No. 7099046 (MH-1)



2. Guide Roller Adj. Screwdriver  
No. 7099028



3. Flat Screwdriver  
(Purchase Locally)



### 4-2-1 How To Use The Fixtures And Tape

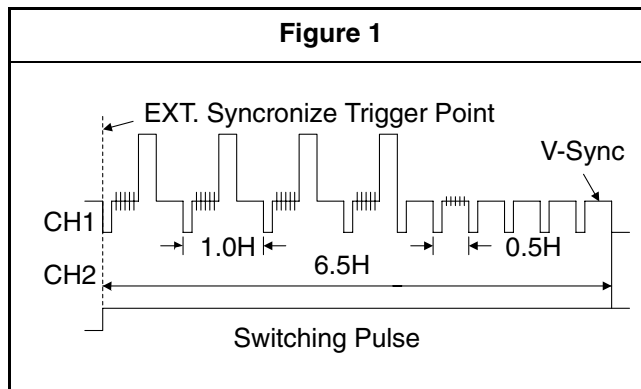
Item No.	Name	Part No.	Adjustment
1	Alignment Tape	7099046	<ul style="list-style-type: none"> <li>● Head Switching Point</li> <li>● Tape Interchangeability Alignment</li> </ul>
2	Guide Roller Adj. Screwdriver	7099028	<ul style="list-style-type: none"> <li>● Guide Roller</li> </ul>
3	Flat Screwdriver	Purchase Locally	<ul style="list-style-type: none"> <li>● X Value Alignment</li> </ul>

# 4-3 ELECTRICAL ADJUSTMENT INSTRUCTIONS

**General Note:** "CBA" is an abbreviation for "Circuit Board Assembly."

**NOTE:**

1. Electrical adjustments are required after replacing circuit components and certain mechanical parts. It is important to do these adjustments only after all repairs and replacements have been completed. Also, do not attempt these adjustments unless the proper equipment is available.
2. To perform these alignment / confirmation procedures, make sure that the tracking control is set in the center position: Press either "CHANNEL ▼" or "CHANNEL ▲" button on the front panel first, then the "PLAY" button on the front panel.



## 4-3-1 Test Equipment Required

1. Oscilloscope: Dual-trace with 10:1 probe, V-Range: 0.001~50V/Div., F-Range: DC~AC-20MHz
2. Alignment Tape (MH-1)

**Reference Notes:**

Playback the Alignment tape and adjust VR501 so that the V-sync front edge of the CH1 video output waveform is at the 6.5H(412.7µs) delayed position from the rising edge of the CH2 head switching pulse waveform.

## 4-3-2 Head Switching Position Adjustment

**Purpose:**

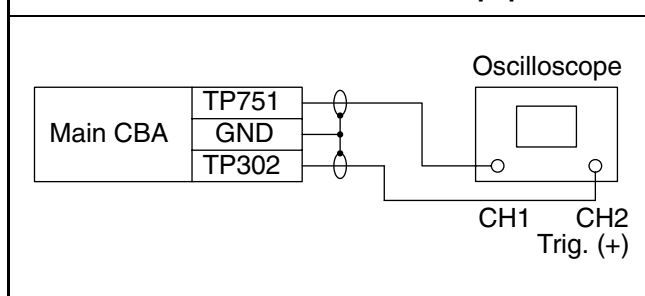
To determine the Head Switching point during playback.

**Symptom of Misadjustment:**

May cause Head Switching noise or vertical jitter in the picture.

Test point	Adj. Point	Mode	Input
TP751(V-OUT) TP302(RF-SW) GND	VR501 (Switching Point) (MAIN CBA)	PLAY (SP)	----
Tape	Measurement Equipment	Spec.	
MH-1	Oscilloscope	6.5H±1H (412.7µs±60µs)	

**Connections of Measurement Equipment**





# 4-4 MECHANICAL ALIGNMENT PROCEDURES

Explanation of alignment for the tape to correctly run starts on the next page. Refer to the information below on this page if a tape gets stuck, for example, in the mechanism due to some electrical trouble of the unit.

## 4-4-1 Service Information

### A. Method for Manual Tape Loading/Unloading

To load a cassette tape manually:

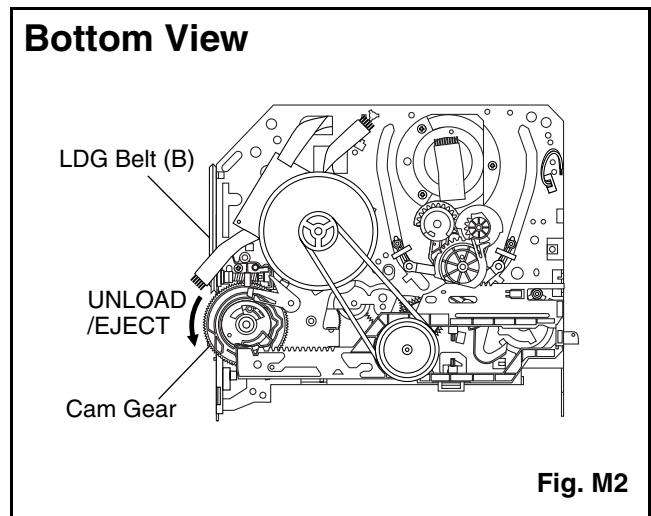
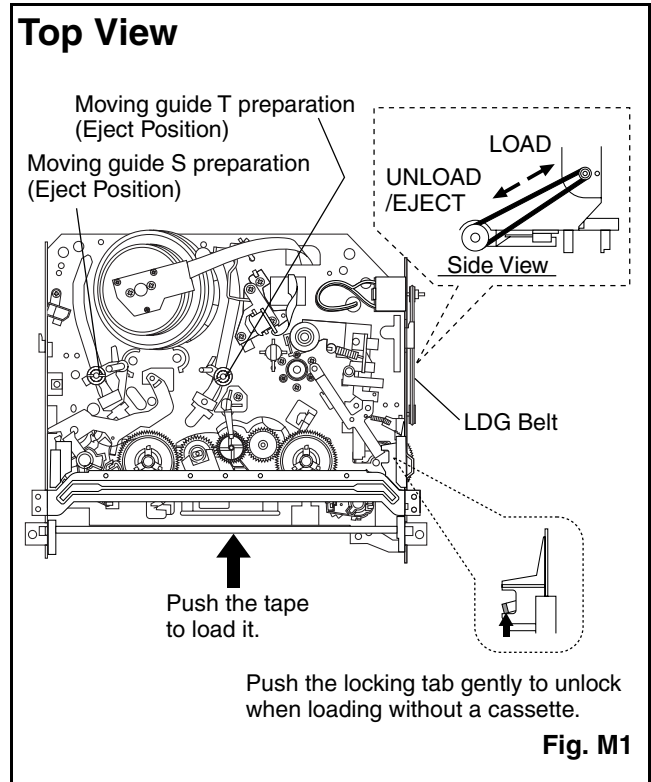
1. Disconnect the AC plug.
2. Remove the Top Case and Front Assembly.
3. Insert a cassette tape. Though the tape will not be automatically loaded, make sure that the cassette tape is all the way in at the inlet of the Cassette Holder. To confirm this, lightly push the cassette tape further in and see if the tape comes back out, by a spring motion, just as much as you have pushed in.
4. Turn the LDG Belt in the appropriate direction shown in Fig. M1 for a minute or two to complete this task.

To unload a cassette tape manually:

1. Disconnect the AC plug.
2. Remove the Top Case and Front Assembly.
3. Make sure that the Moving guide preparations are in the Eject Position.
4. Turn the LDG Belt in the appropriate direction shown in Fig. M1 until the Moving guide preparations come to the Eject Position. Stop turning when the preparations begin clicking or can not be moved further. However, the tape will be left wound around the cylinder.
5. Turn the LDG Belt in the appropriate direction continuously, and the cassette tape will be ejected. Allow a minute or two to complete this task.

### B. Method to place the Cassette Holder in the tape-loaded position without a cassette tape

1. Disconnect the AC Plug.
2. Remove the Top Case and Front Assembly.
3. Turn the LDG Belt in the appropriate direction shown in Fig. M1. Release the locking tabs shown in Fig. M1 and continue turning the LDG Belt until the Cassette Holder comes to the tape-loaded position. Allow a minute or two to complete this task.



## 4-4-2 Tape Interchangeability Alignment

Note:

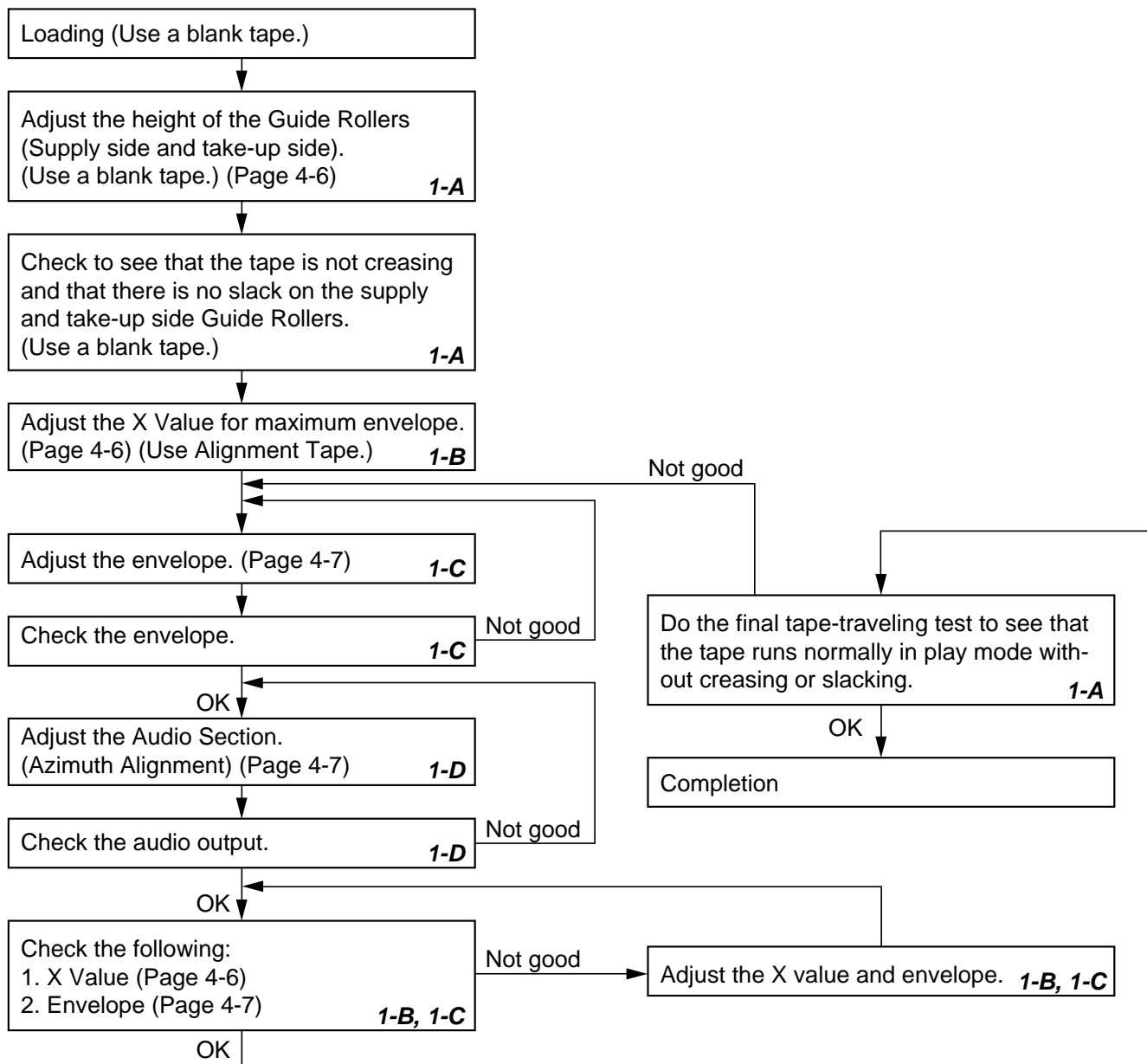
To do these alignment procedures, make sure that the Tracking Control Circuit is set to the center position every time a tape is loaded or unloaded. (Refer to page 4-7, procedure 1-C, step 2.)

### Equipment required:

- Dual Trace Oscilloscope
- VHS Alignment Tape (MH-1)
- Guide Roller Adj. Screwdriver
- Flat Screwdriver (Purchase Locally)

Note: Before starting this Mechanical Alignment, do all Electrical Adjustment procedures.

### Flowchart of Alignment for tape traveling



## 1-A. Preliminary/Final Checking and Alignment of Tape Path

### Purpose:

To make sure that the tape path is well stabilized.

### Symptom of Misalignment:

If the tape path is unstable, the tape will be damaged.

**Note:** Do not use an Alignment Tape for this procedure. If the unit is not correctly aligned, the tape may be damaged.

1. Playback a blank cassette tape and check to see that the tape runs without creasing at Guide Rollers [2] and [3], and at points A and B on the lead surface. (Refer to Fig. M3 and M4.)
2. If creasing is apparent, align the height of the guide rollers by turning the top of Guide Rollers [2] and [3] with a Guide Roller Adj. Screwdriver. (Refer to Fig. M3 and M5.)

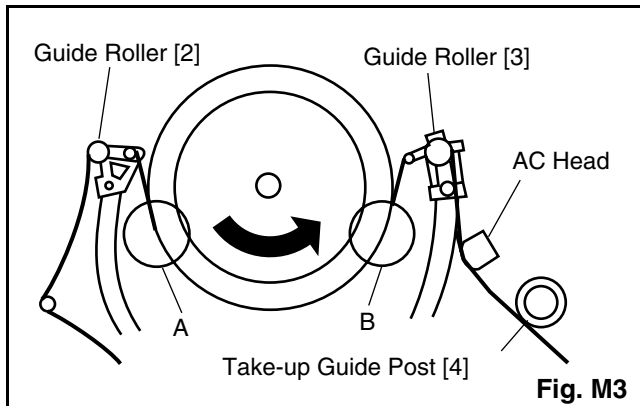


Fig. M3

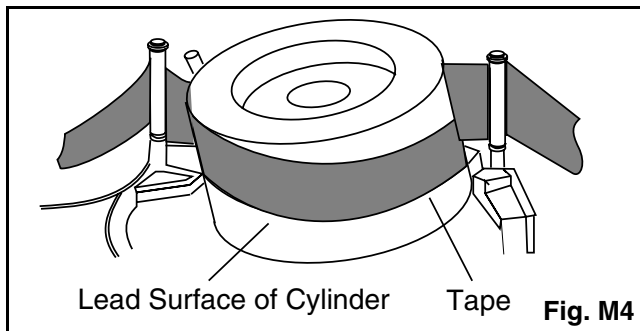


Fig. M4

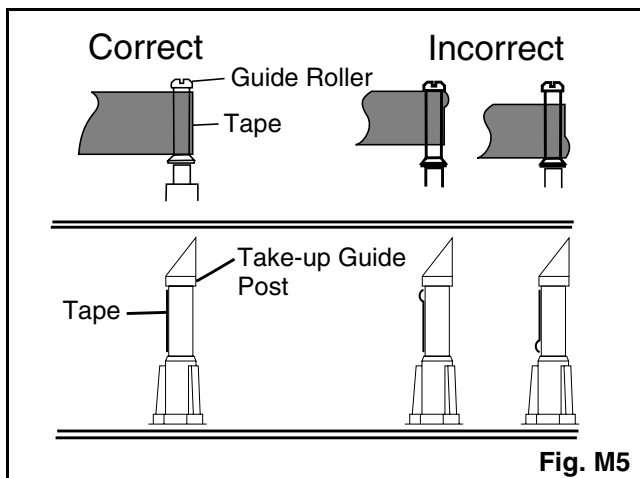


Fig. M5

3. Check to see that the tape runs without creasing at Take-up Guide Post [4] or without snaking between Guide Roller [3] and AC Head. (Fig. M3 and M5)
4. If creasing or snaking is apparent, adjust the Tilt Adj. Screw of the AC Head. (Fig. M6)

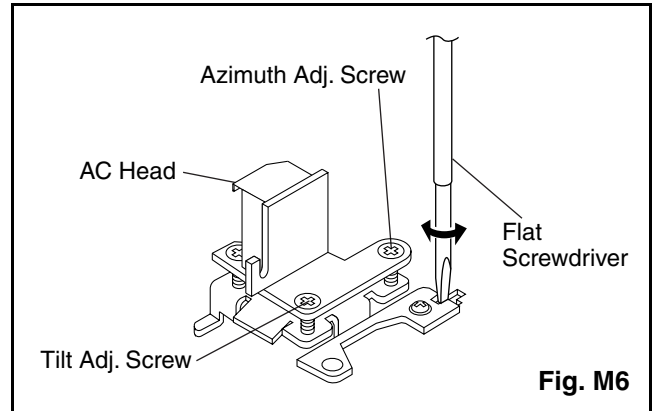


Fig. M6

## 1-B. X Value Alignment

### Purpose:

To align the Horizontal Position of the Audio/Control/ Erase Head.

### Symptom of Misalignment:

If the Horizontal Position of the Audio/Control/Erase Head is not properly aligned, maximum envelope cannot be obtained at the Neutral position of the Tracking Control Circuit.

1. Connect the oscilloscope to TP301 (C-PB) and TP513 (CTL) on the Main CBA. Use TP302 (RF-SW) as a trigger.
2. Playback the Gray Scale of the Alignment Tape (MH-1) and confirm that the PB FM signal is present.
3. Set the Tracking Control Circuit to the center position by pressing CH UP button then "PLAY" button on the unit. (Refer to note on bottom of page 4-7.)
4. Use the Flat Screwdriver so that the PB FM signal at TP301 (C-PB) is maximum. (Fig. M6)
5. Press CH UP button on the unit until the CTL waveform has shifted by approx. +2ms. Make sure that the envelope is simply attenuated (shrinks in height) during this process so that you will know the envelope has been at its peak.

- Press CH DOWN button on the unit until the CTL waveform has shifted from its original position (not the position achieved in step 5, but the position of CTL waveform in step 4) by approximately -2ms. Make sure that the envelope is simply attenuated (shrinks in height) once CTL waveform passes its original position and is further brought in the minus direction.
- Set the Tracking Control Circuit to the center position by pressing CH UP button and then "PLAY" button.

### 1-C. Checking/Adjustment of Envelope Waveform

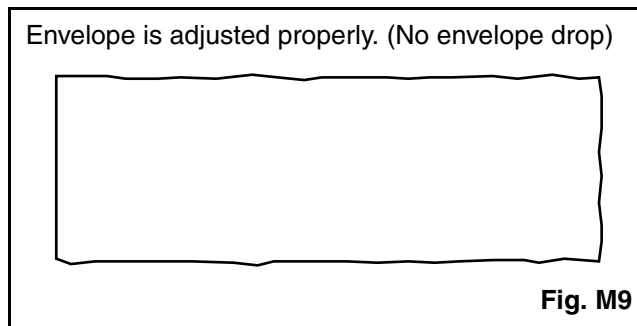
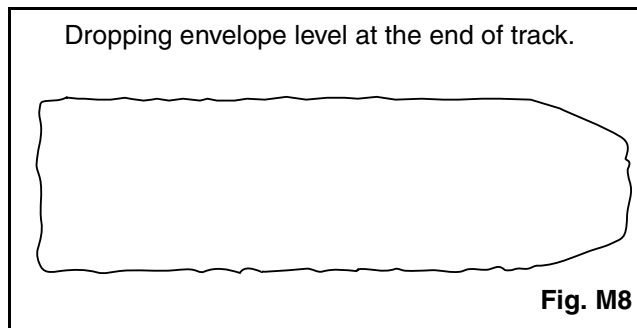
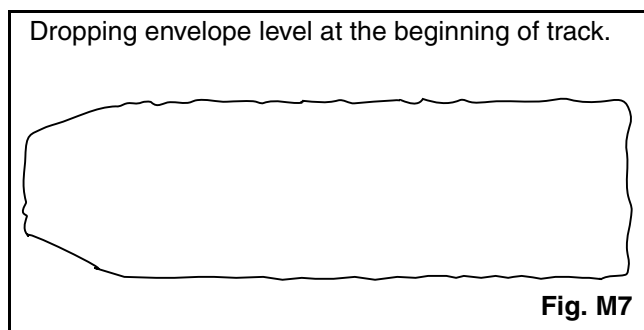
**Purpose:**

To achieve a satisfactory picture and precise tracking.

**Symptom of Misalignment:**

If the envelope output is poor, noise will appear in the picture. The tracking will then lose precision and the playback picture will be distorted by any slight variation of the Tracking Control Circuit.

- Connect the oscilloscope to TP301 (C-PB) on the Main CBA. Use TP302 (RF-SW) as a trigger.
- Playback the Gray Scale on the Alignment Tape (MH-1). Set the Tracking Control Circuit to the center position by pressing CH UP button and then "PLAY" button on the unit. Adjust the height of Guide Rollers [2] and [3] (Fig. M3, Page 4-6) watching the oscilloscope display so that the envelope becomes as flat as possible. To do this adjustment, turn the top of the Guide Roller with the Guide Roller Adj. Screwdriver.
- If the envelope is as shown in Fig. M7, adjust the height of Guide Roller [2] (Refer to Fig. M3) so that the waveform looks like the one shown in Fig. M9.
- If the envelope is as shown in Fig. M8, adjust the height of Guide Roller [3] (Refer to Fig. M3) so that the waveform looks like the one shown in Fig. M9.
- When Guide Rollers [2] and [3] (Refer to Fig.M3) are aligned properly, there is no envelope drop either at the beginning or end of track as shown in Fig. M9.



Note: Upon completion of the adjustment of Guide Rollers [2] and [3] (Refer to Fig. M3), check the X Value by pushing the CH UP or DOWN buttons alternately, to check the symmetry of the envelope. Check the number of pushes to ensure center position. The number of pushes CH UP button to achieve 1/2 level of envelope should match the number of pushes CH DOWN button from center. If required, redo the "X Value Alignment."

### 1-D. Azimuth Alignment of Audio/Control/ Erase Head

**Purpose:**

To correct the Azimuth alignment so that the Audio/Control/Erase Head meets tape tracks properly.

**Symptom of Misalignment:**

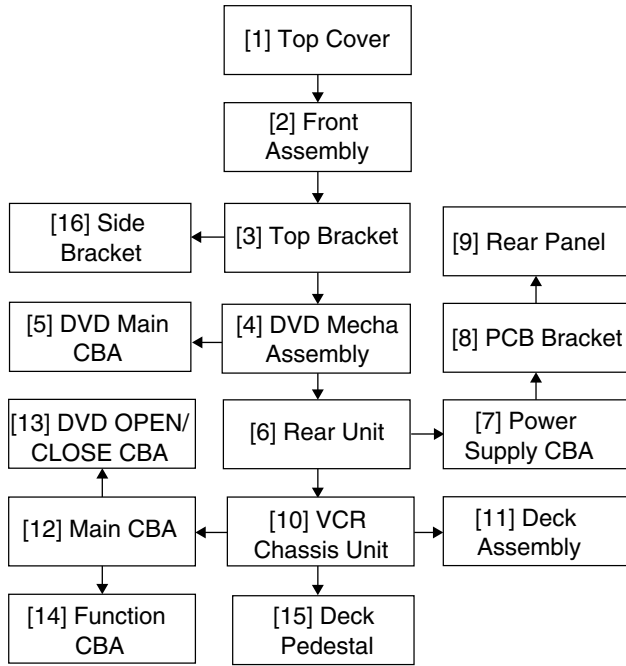
If the position of the Audio/Control/Erase Head is not properly aligned, the Audio S/N Ratio or Frequency Response will be poor.

- Connect the oscilloscope to the audio output jack on the rear side of the deck.
- Playback the alignment tape (MH-1) and confirm that the audio signal output level is 8kHz.
- Adjust Azimuth Adj. Screw so that the output level on the AC Voltmeter or the waveform on the oscilloscope is at maximum. (Fig. M6)

## 5-1 CABINET DISASSEMBLY INSTRUCTIONS

### 5-1-1 Disassembly Flowchart

This flowchart indicates the disassembly steps to gain access to item(s) to be serviced. When reassembling, follow the steps in reverse order. Bend, route, and dress the cables as they were originally.



### 5-1-2 Disassembly Method

ID/ LOC. No.	PART	REMOVAL		
		Fig. No.	REMOVE/*UNHOOK/ UNLOCK/RELEASE/ UNPLUG/DESOLDER	Note
[1]	Top Cover	D1	7(S-1)	-
[2]	Front Assembly	D2	(S-3), *7(L-1)	1 1-1 1-2
[3]	Top Bracket	D2	4(S-2)	-
[4]	DVD Mecha Assembly	D3	3(S-4), *CN401, *CN601	-
[5]	DVD Main CBA	D4	2(S-5), *CN201, *CN301	2 2-1 2-2 2-3 3
[6]	Rear Unit	D5	5(S-6), 4(S-7), CN1005	-

ID/ LOC. No.	PART	REMOVAL		
		Fig. No.	REMOVE/*UNHOOK/ UNLOCK/RELEASE/ UNPLUG/DESOLDER	Note
[7]	Power Supply CBA	D6	4(S-8)	-
[8]	PCB Bracket	D6	3(S-9)	-
[9]	Rear Panel	D6	-----	-
[10]	VCR Chassis Unit	D7	5(S-10), 4(S-11)	-
[11]	Deck Assembly	D8	Desolder, 2(S-12)	4,5
[12]	Main CBA	D8	-----	-
[13]	DVD OPEN/ CLOSE CBA	D8	-----	-
[14]	Function CBA	D8	-----	-
[15]	Deck Pedestal	D9	7(S-13)	-
[16]	Side Bracket	D9	(S-14)	-

↓ (1)      ↓ (2)      ↓ (3)      ↓ (4)      ↓ (5)

**Note:**

- (1): Identification (location) No. of parts in the figures
- (2): Name of the part
- (3): Figure Number for reference
- (4): Identification of parts to be removed, unhooked, unlocked, released, unplugged, unclamped, or desoldered.  
P=Spring, L=Locking Tab, S=Screw, CN=Connector  
\*=Unhook, Unlock, Release, Unplug, or Desolder  
e.g. 2(S-2) = two Screws (S-2),  
2(L-2) = two Locking Tabs (L-2)
- (5): Refer to "Reference Notes."

## Reference Notes

**CAUTION 1:** Locking Tabs (L-1) are fragile. Be careful not to break them.

1-1. Remove Screw (S-3).

1-2. Release seven Locking Tabs (L-1) (to do this, first release five Locking Tabs (A) at the side and top, and then release two Locking Tabs (B) at the bottom.)

**CAUTION 2:** Electrostatic breakdown of the laser diode in the optical system block may occur as a potential difference caused by electrostatic charge accumulated on cloth, human body etc., during unpacking or repair work.

To avoid damage of pickup follow next procedures.

2-1. Slide the pickup unit as shown in Fig. D4.

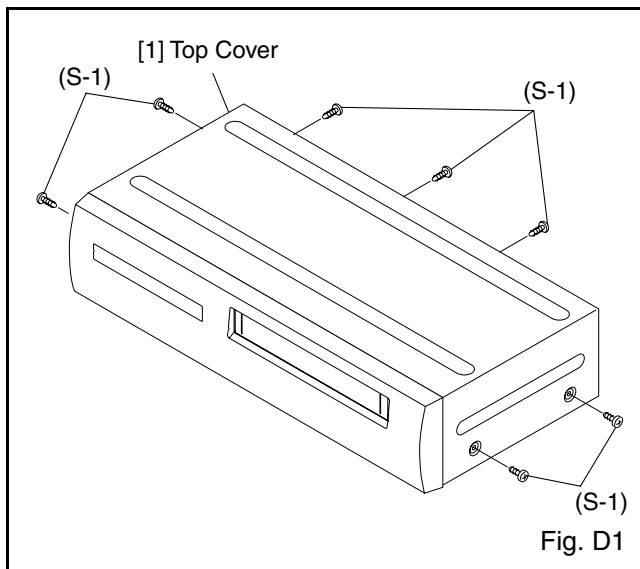
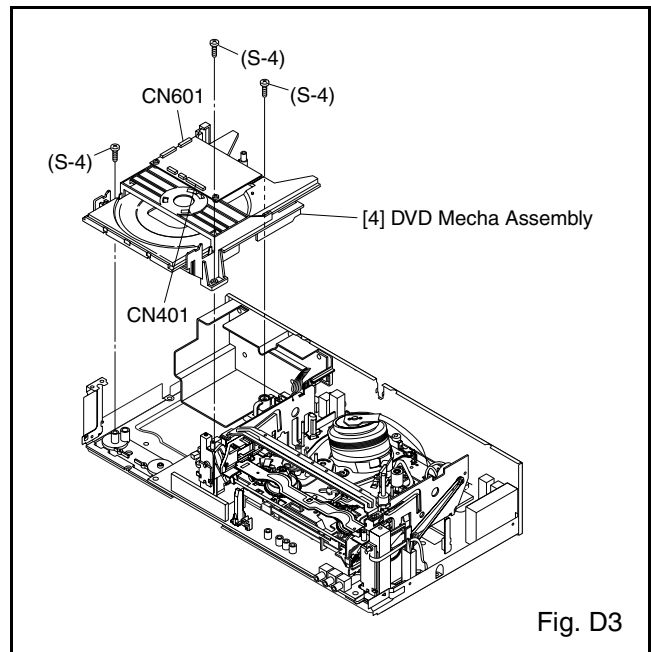
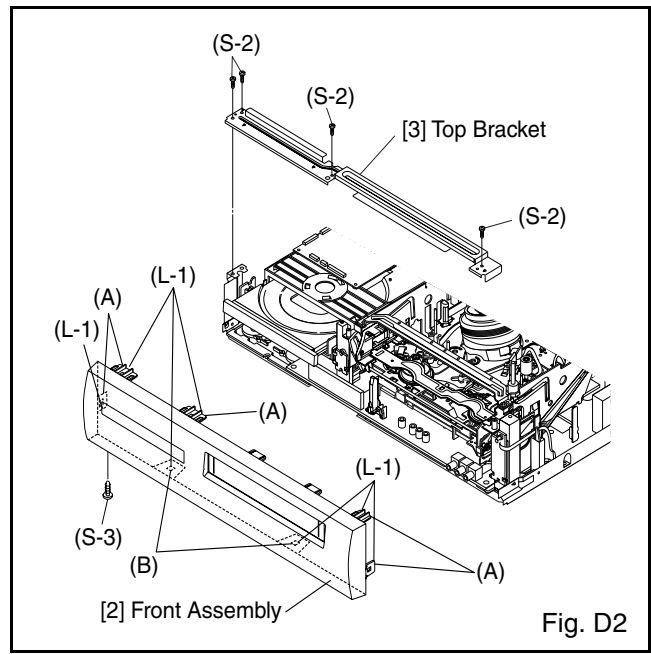
2-2. Short the three short lands of FPC cable with solder before removing the FFC cable (CN301) from it. If you disconnect the FFC cable (CN301), the laser diode of pickup will be destroyed. (Fig. D4)

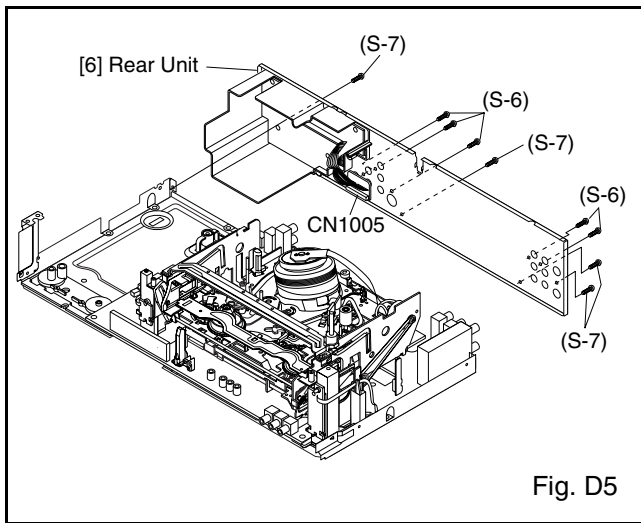
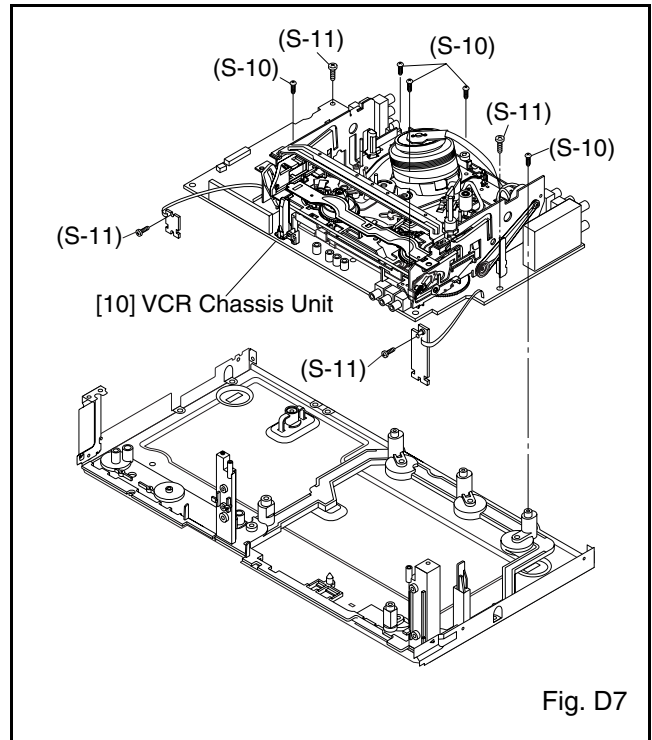
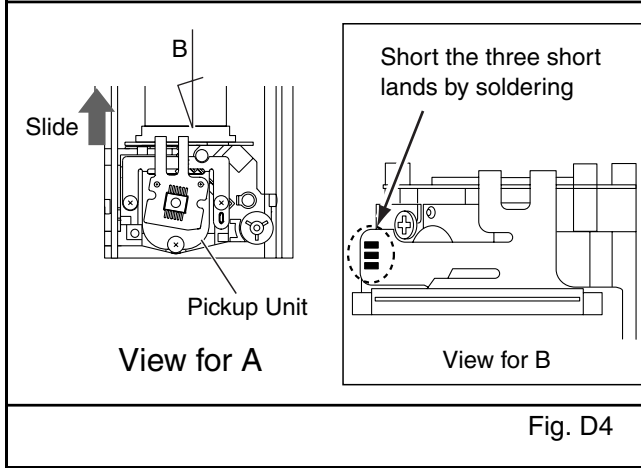
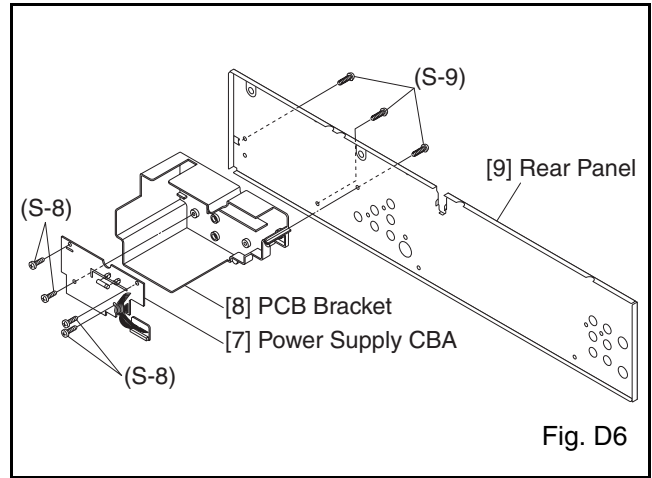
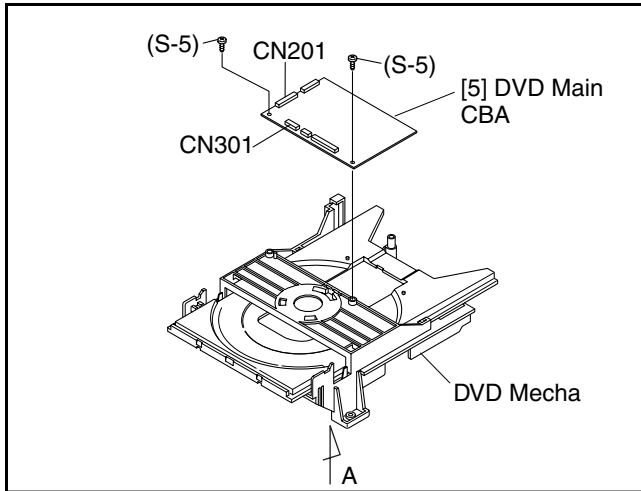
2-3. Disconnect Connector (CN201). Remove two Screws (S-5) and lift the DVD Main CBA. (Fig. D4)

**CAUTION 3:** When reassembling, confirm the FFC cable (CN301) is connected completely. Then remove the solder from the three short lands of FPC cable. (Fig. D4)

**CAUTION 4:** When reassembling, solder wire jumpers as shown in Fig. D8.

**CAUTION 5:** Before installing the Deck Assembly, be sure to place the pin of LD-SW on Main CBA as shown in Fig. D8. Then, install the Deck Assembly while aligning the hole of Cam Gear with the pin of LD-SW, the shaft of Cam Gear with the hole of LD-SW as shown in Fig. D8.





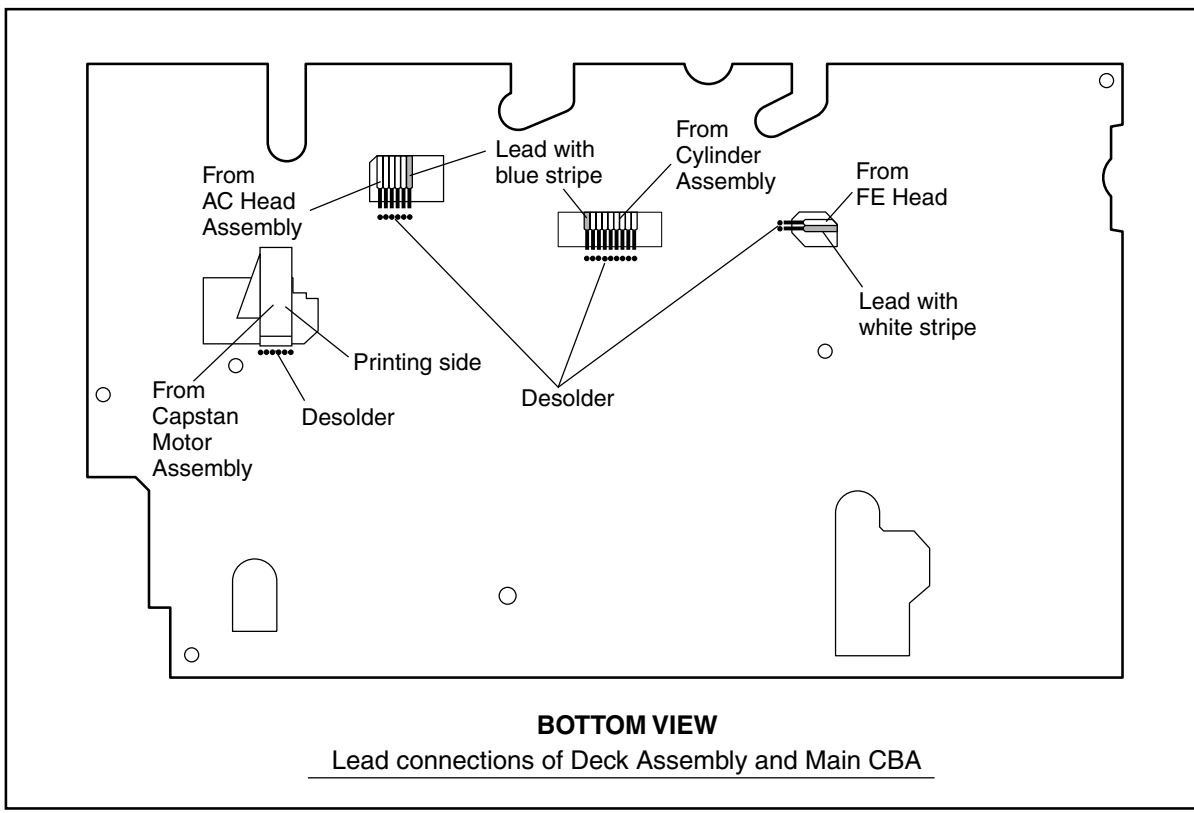
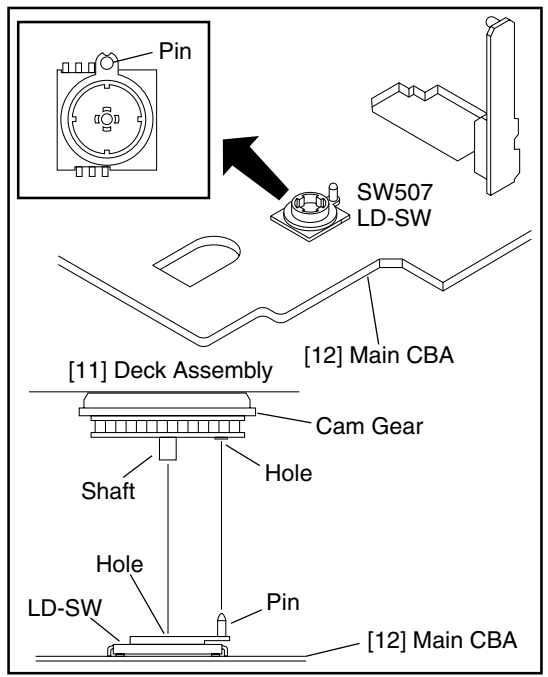
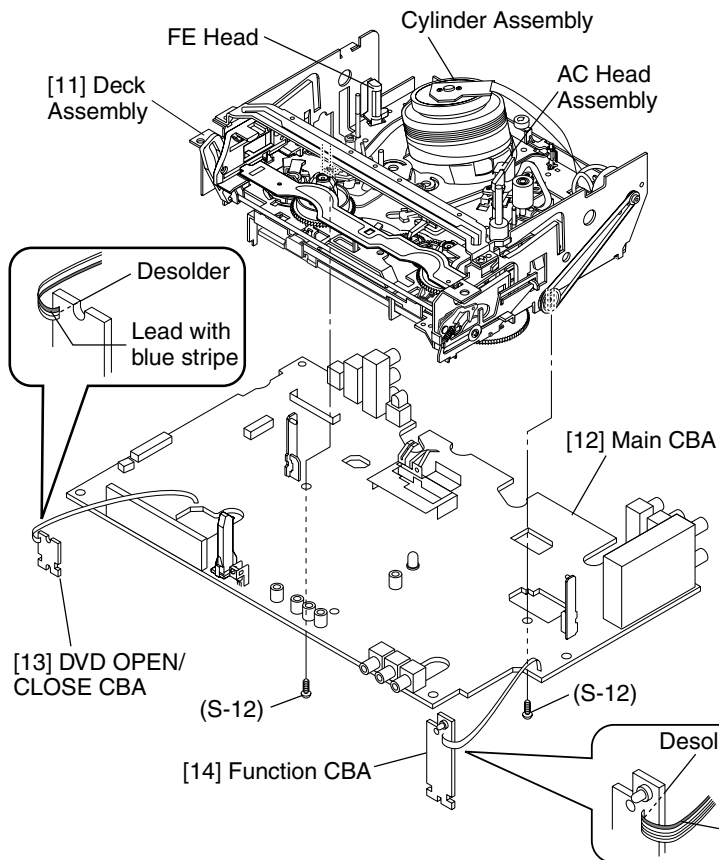
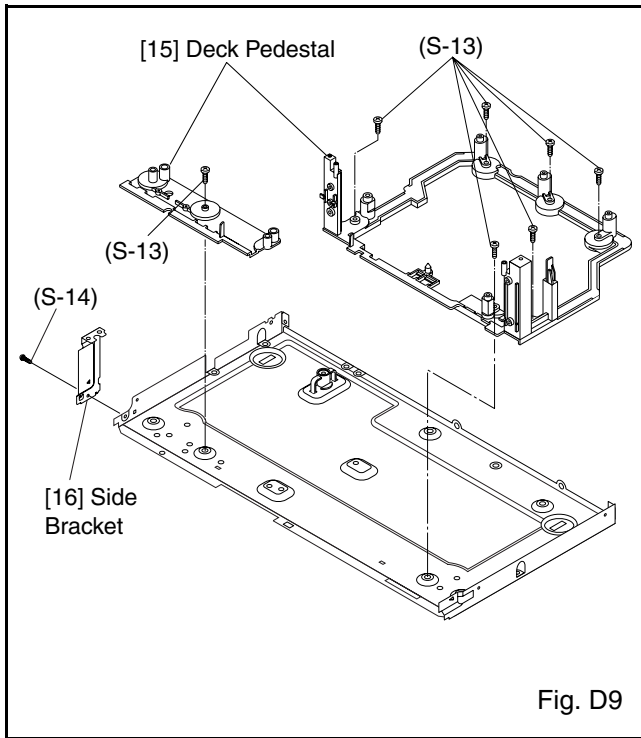


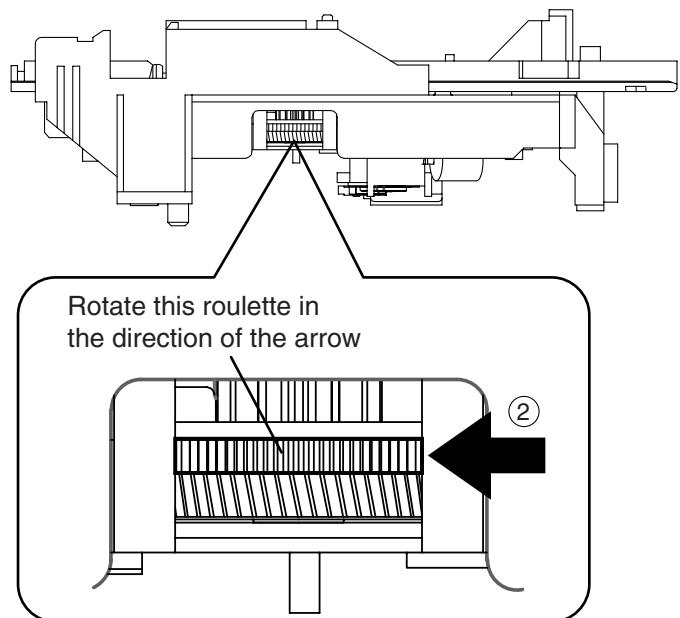
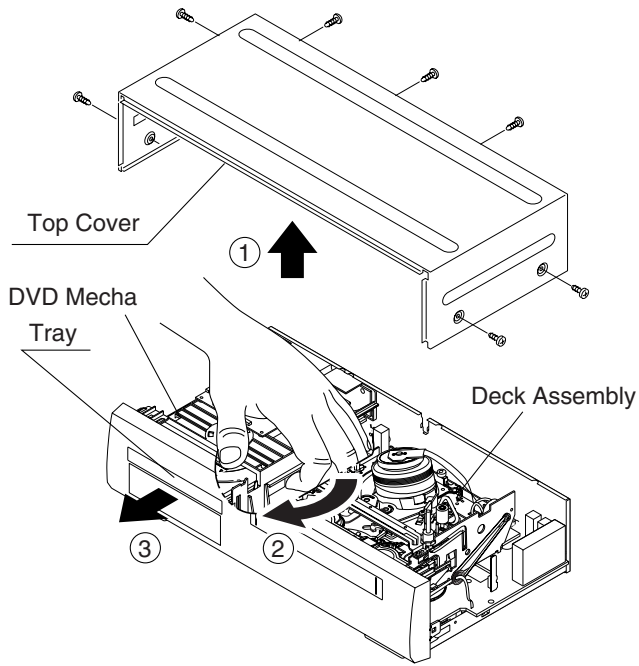
Fig. D8





## To Remove the Disc Manually

1. Remove the Top Cover.
2. Rotate this roulette in the direction of the arrow as shown below.



## 5-2 DISASSEMBLY/ASSEMBLY PROCEDURES OF DECK MECHANISM

Before following the procedures described below, be sure to remove the deck assembly from the cabinet. (Refer to CABINET DISASSEMBLY INSTRUCTIONS on page 5-1.)

All the following procedures, including those for adjustment and replacement of parts, should be done in Eject mode; see the positions of [41] and [42] in Fig. DM1 on page 5-8. When reassembling, follow the steps in reverse order.

STEP /LOC. No.	START-ING No.	PART		REMOVAL		INSTALLATION
				Fig. No.	REMOVE/*UNHOOK/ UNLOCK/RELEASE/ UNPLUG/DESOLDER	ADJUSTMENT CONDITION
[1]	[1]	Guide Holder A	T	DM3	2(S-1)	
[2]	[1]	Cassette Holder Assembly	T	DM4		
[3]	[2]	Slider (SP)	T	DM5	*(L-1)	
[4]	[2]	Slider (TU)	T	DM5	*(L-2)	
[5]	[4]	Lock Lever	T	DM5	*(L-3), *(P-1)	
[6]	[2]	Cassette Plate	T	DM5		
[7]	[7]	Cylinder Assembly	T	DM1,DM6	Desolder, 3(S-2)	
[8]	[8]	Loading Motor Assembly	T	DM1,DM7	Desolder, LDG Belt, 2(S-3)	
[9]	[9]	AC Head Assembly	T	DM1,DM7	(S-4)	
[10]	[2]	Tape Guide Arm Assembly	T	DM1,DM8	*(P-2)	
[11]	[10]	C Door Opener	T	DM1,DM8	*(L-4)	
[12]	[11]	Pinch Arm (B)	T	DM1,DM8	*(P-3)	
[13]	[12]	Pinch Arm Assembly	T	DM1,DM8		
[14]	[14]	FE Head Assembly	T	DM1,DM9	(S-5)	
[15]	[15]	Prism	T	DM1,DM9	(S-6)	
[16]	[2],[15]	Sensor Gear	T	DM1,DM15		
[17]	[2]	Slider Shaft	T	DM10	*(L-5)	
[18]	[17]	C Drive Lever (SP)	T	DM10		
[19]	[17]	C Drive Lever (TU)	T	DM10	(S-7), *(P-4)	
[20]	[7],[8], [10]	Capstan Motor	B	DM2,DM11	3(S-8), Cap Belt	
[21]	[21]	Clutch Assembly	B	DM2,DM12	(C-1)	
[22]	[22]	Cam Holder (F) Assembly	B	DM2,DM12	*(L-6)	
[23]	[23]	Cam Gear (B)	B	DM2,DM12	(C-4)*(P-5)	
[24]	[24]	Mode Gear	B	DM2,DM13	(C-2)	
[25]	[21],[23], [24]	Mode Lever	B	DM2,DM13	(C-3), *(L-8)	
[26]	[22]	Worm Holder	B	DM2,DM13	(S-9), *(L-9), *(L-10)	
[27]	[26]	Pulley Assembly	B	DM2,DM13		
[28]	[25],[26]	Cam Gear (A)	B	DM2,DM13		
[29]	[25]	Idler Gear	B	DM1,DM14		
[30]	[29]	Idler Arm	B	DM1,DM14	*(L-11)	
[31]	[25]	BT Arm	B	DM2,DM14	*(P-6)	
[32]	[25]	Loading Arm (SP) Assembly	B	DM2,DM14		(+)Refer to Alignment Sec. Page 5-14

STEP /LOC. No.	START-ING No.	PART		REMOVAL		INSTALLATION
				Fig. No.	REMOVE/*UNHOOK/ UNLOCK/RELEASE/ UNPLUG/DESOLDER	ADJUSTMENT CONDITION
[33]	[32]	Loading Arm (TU) Assembly	B	DM2,DM14		(+)Refer to Alignment Sec. Page 5-14
[34]	[2],[25]	M Brake (TU) Assembly	T	DM1,DM15	*(P-7), Brake Belt	
[35]	[2],[25]	M Brake (SP) Assembly	T	DM1,DM15	*(P-8)	
[36]	[35]	Tension Lever Assembly	T	DM1,DM15		
[37]	[36]	T Lever Holder	T	DM15	*(L-12)	
[38]	[34]	Reel (TU)(D2)	T	DM1,DM15		
[39]	[38]	M Gear	T	DM1,DM15		
[40]	[36]	Reel (SP)(D2)	T	DM1,DM15		
[41]	[32],[36]	Moving Guide S Preparation	T	DM1,DM16		
[42]	[33]	Moving Guide T Preparation	T	DM1,DM16		
[43]	[19]	TG Post Assembly	T	DM1,DM16	*(L-13)	
[44]	[28]	Rack Assembly	R	DM17		(+)Refer to Alignment Sec. Page 5-14
[45]	[44]	F Door Opener	R	DM17		
[46]	[46]	Cleaner Assembly	T	DM1,DM6		
[47]	[46]	CL Post	T	DM6	*(L-14)	
↓ (1)	↓ (2)	↓ (3)	↓ (4)	↓ (5)	↓ (6)	↓ (7)

(1): Follow steps in sequence. When reassembling, follow the steps in reverse order.

These numbers are also used as identification (location) No. of parts in the figures.

(2): Indicates the part to start disassembling with in order to disassemble the part in column (1).

(3): Name of the part

(4): Location of the part: T=Top B=Bottom R=Right L=Left

(5): Figure Number

(6): Identification of parts to be removed, unhooked, unlocked, released, unplugged, unclamped, or desoldered.

P=Spring, W=Washer, C=Cut Washer, S=Screw, \*=Unhook, Unlock, Release, Unplug, or Desolder

e.g., 2(L-2) = two Locking Tabs (L-2).

(7): Adjustment Information for Installation

(+):Refer to Deck Exploded Views for lubrication.

# Top View

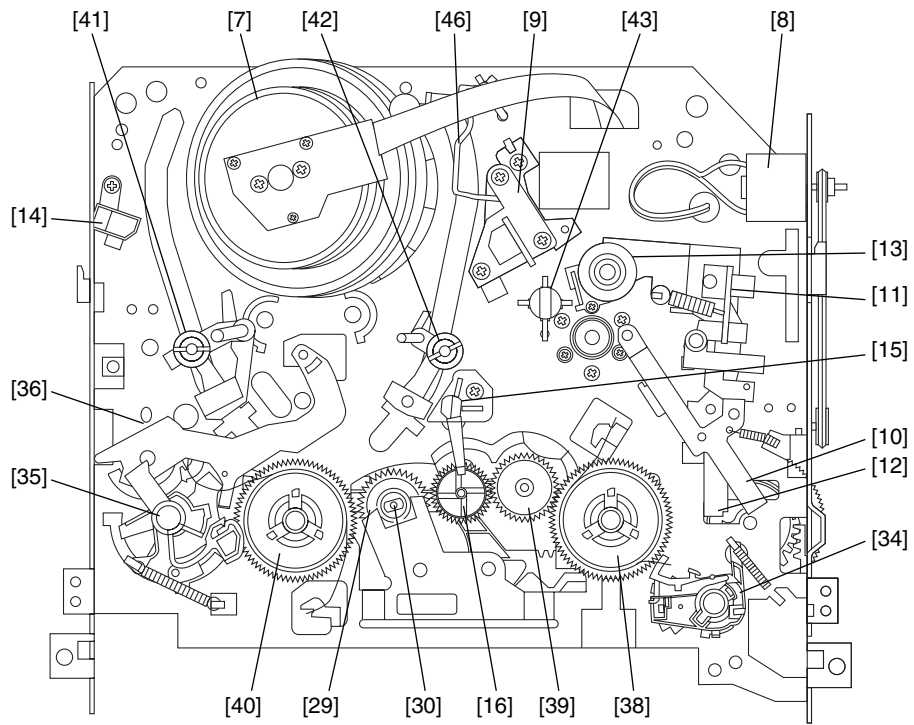


Fig. DM1

# Bottom View

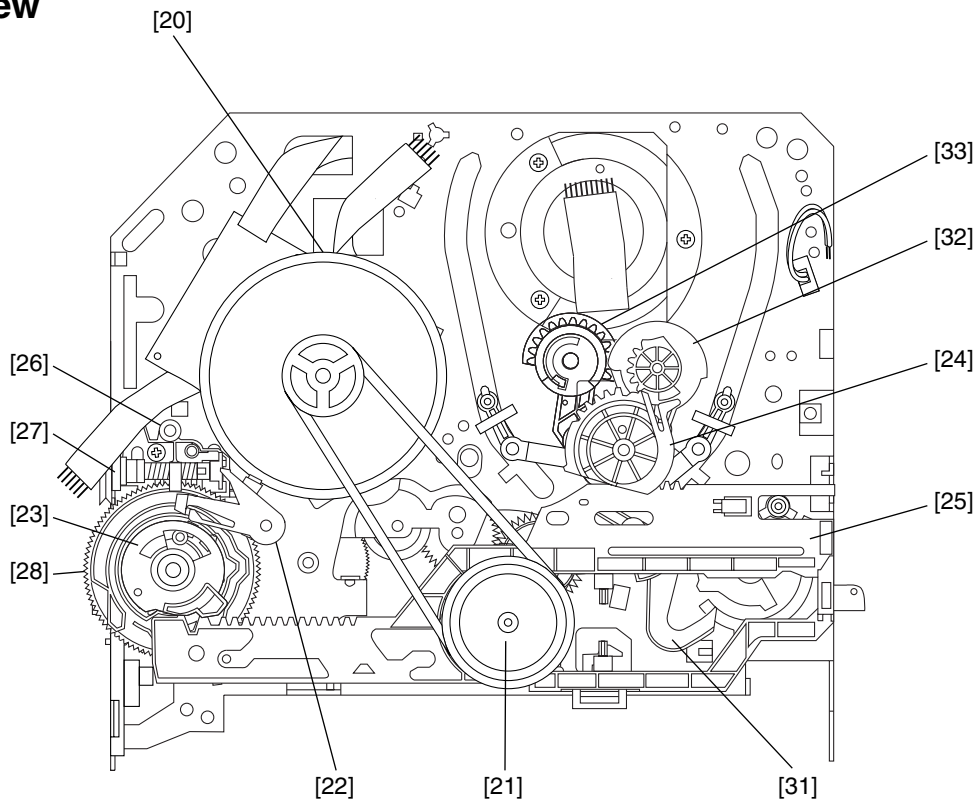


Fig. DM2

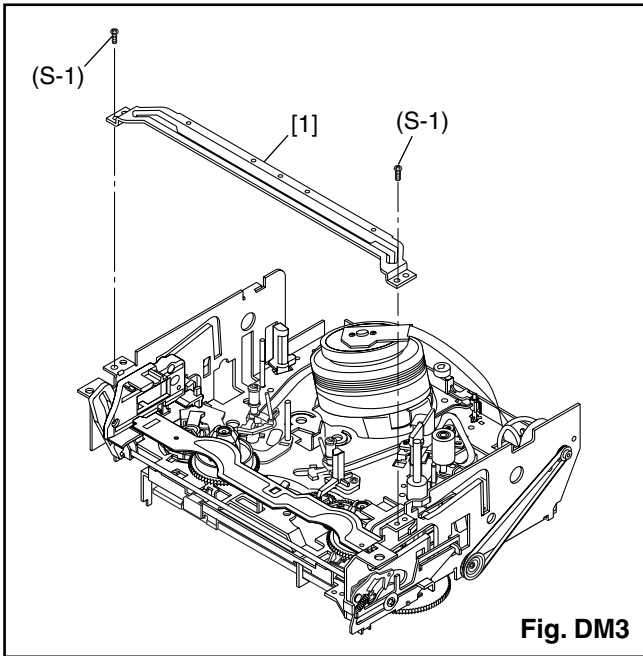


Fig. DM3

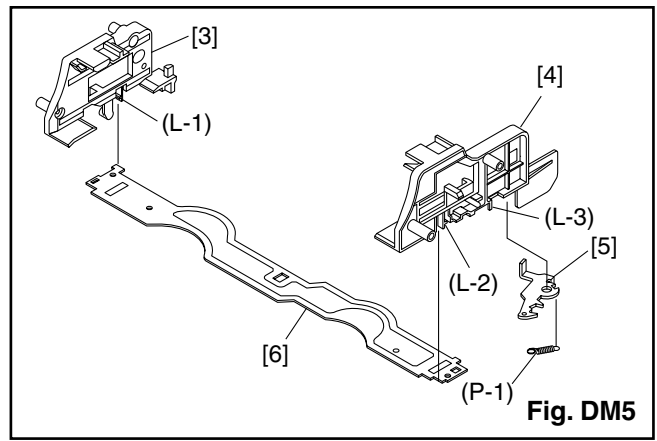


Fig. DM5

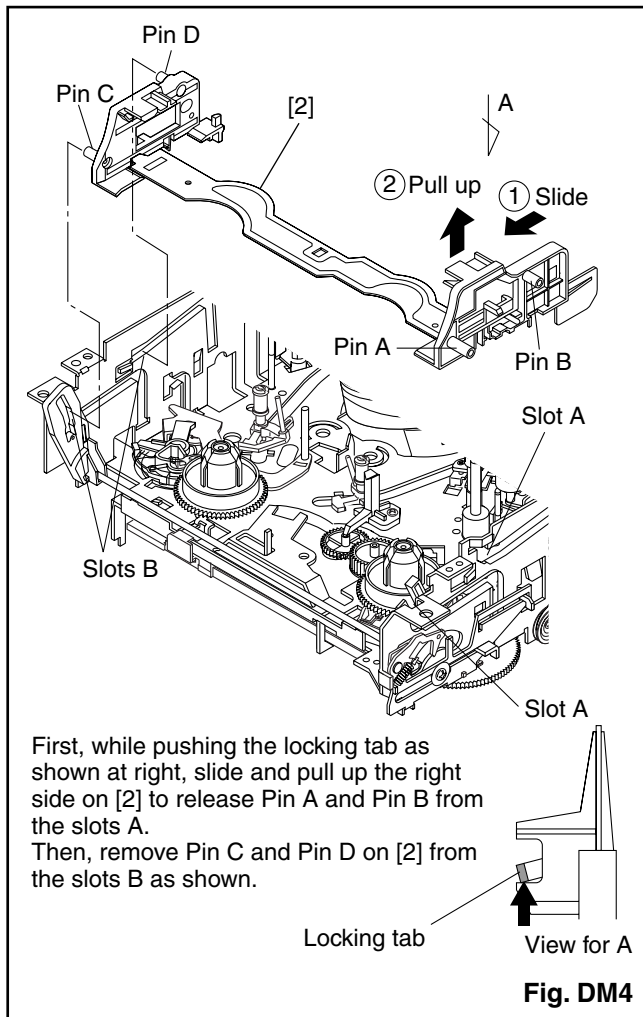


Fig. DM4

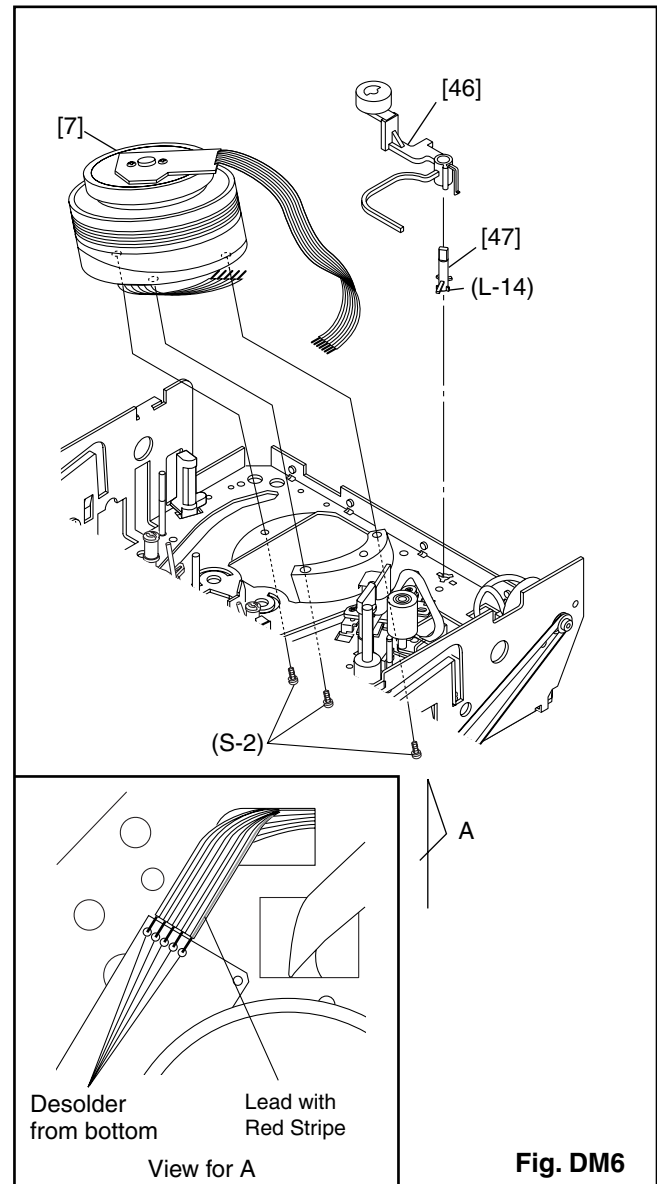
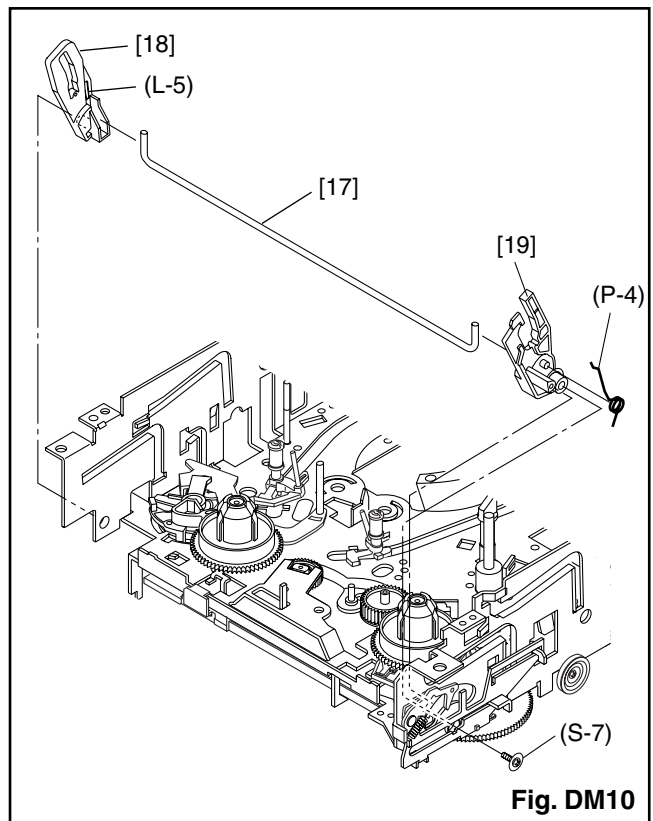
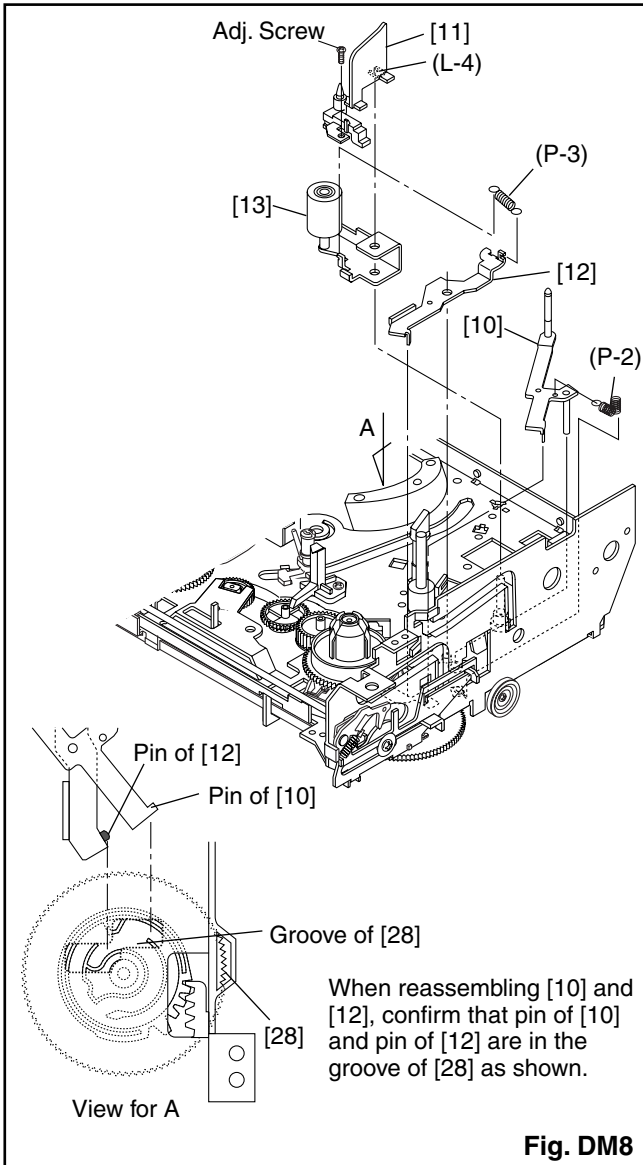
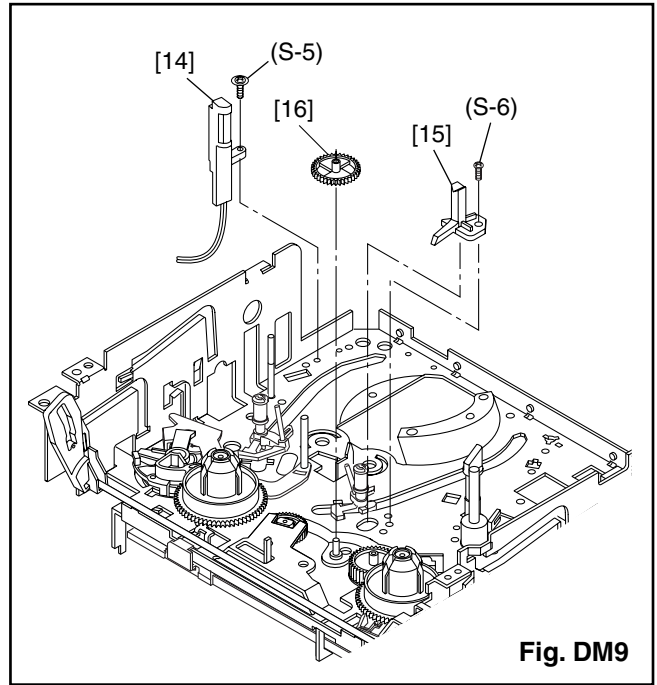
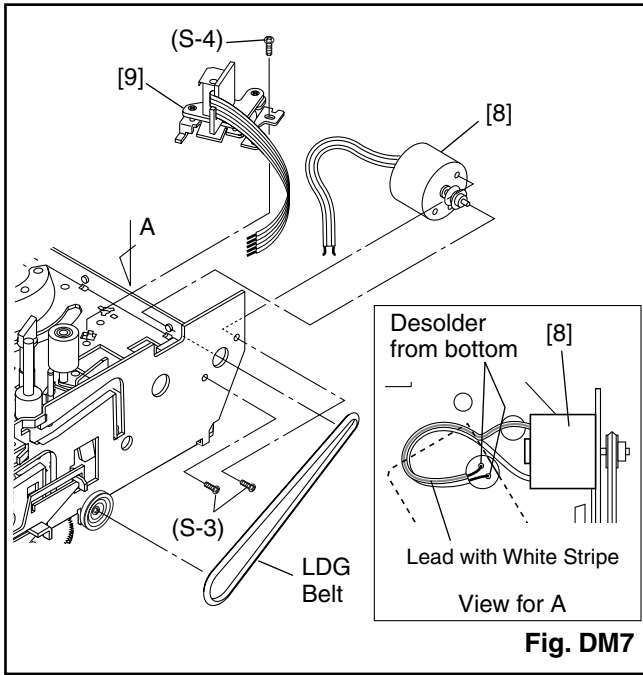
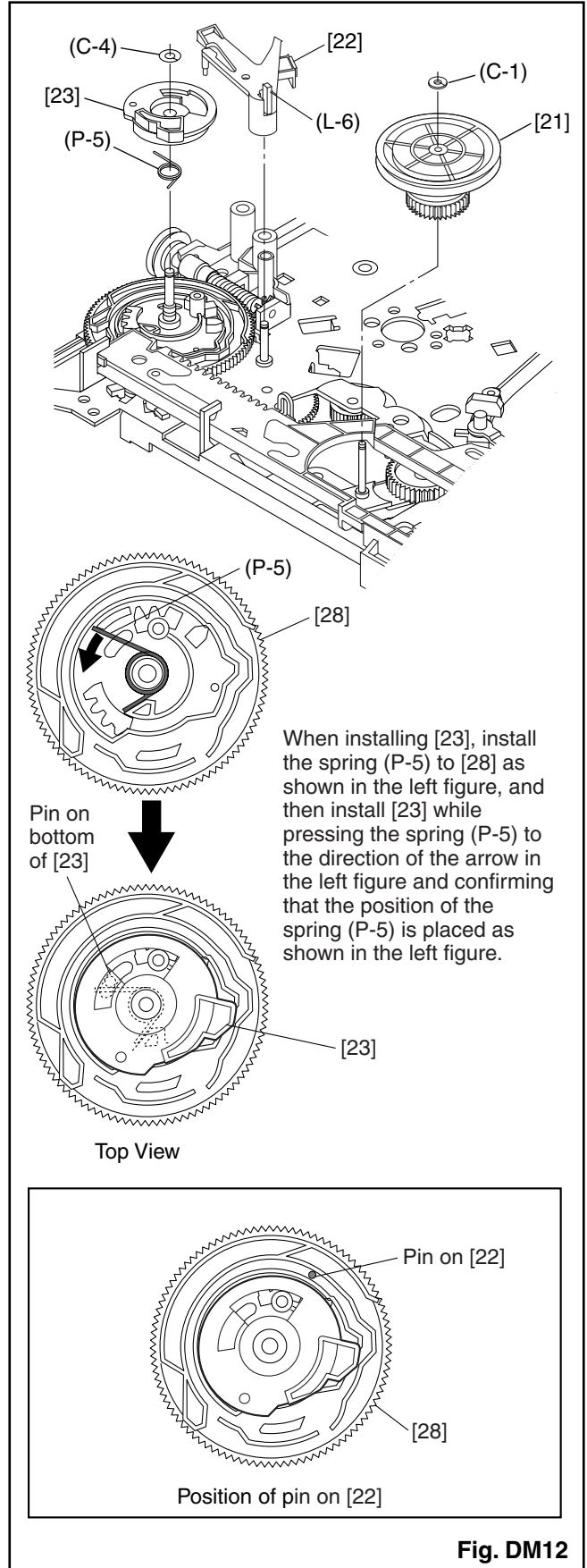
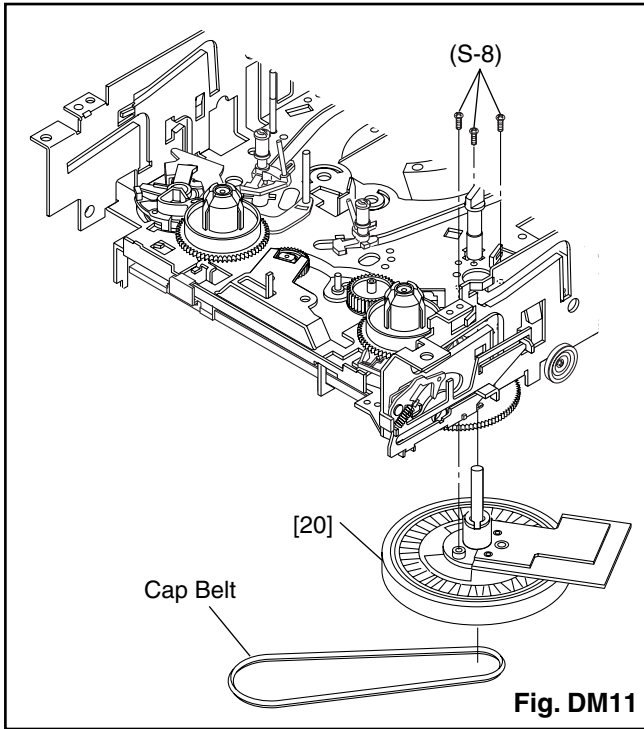
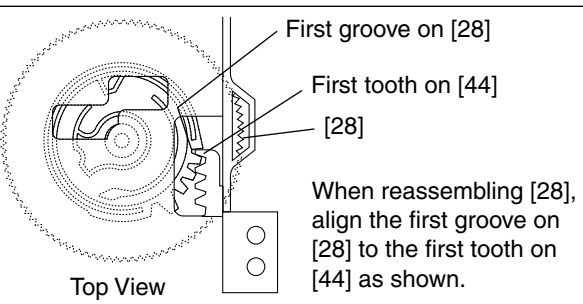
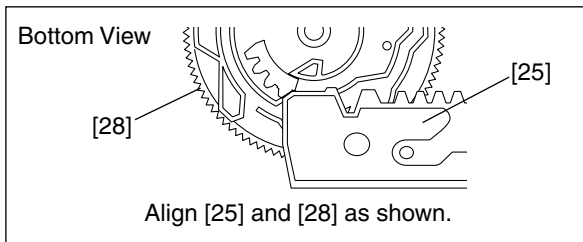
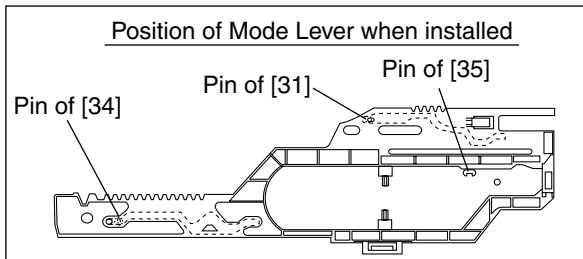
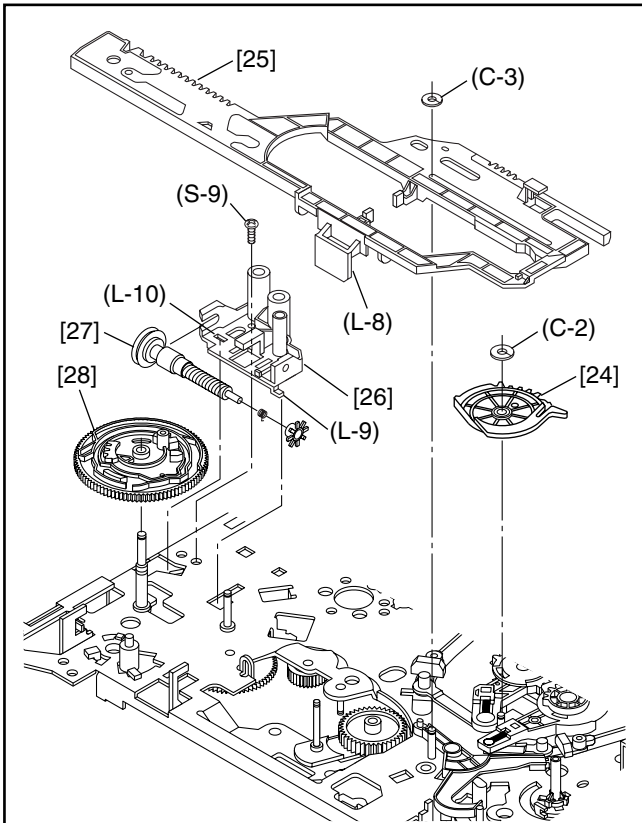


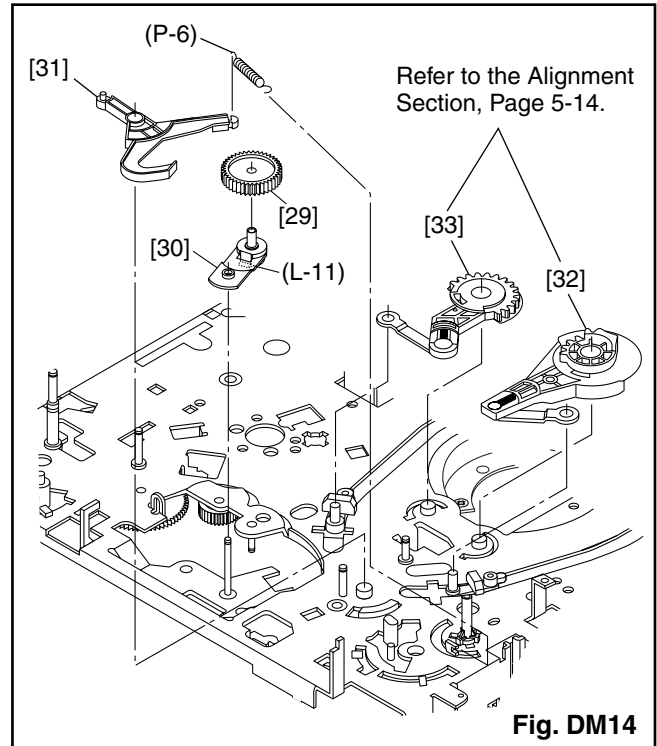
Fig. DM6



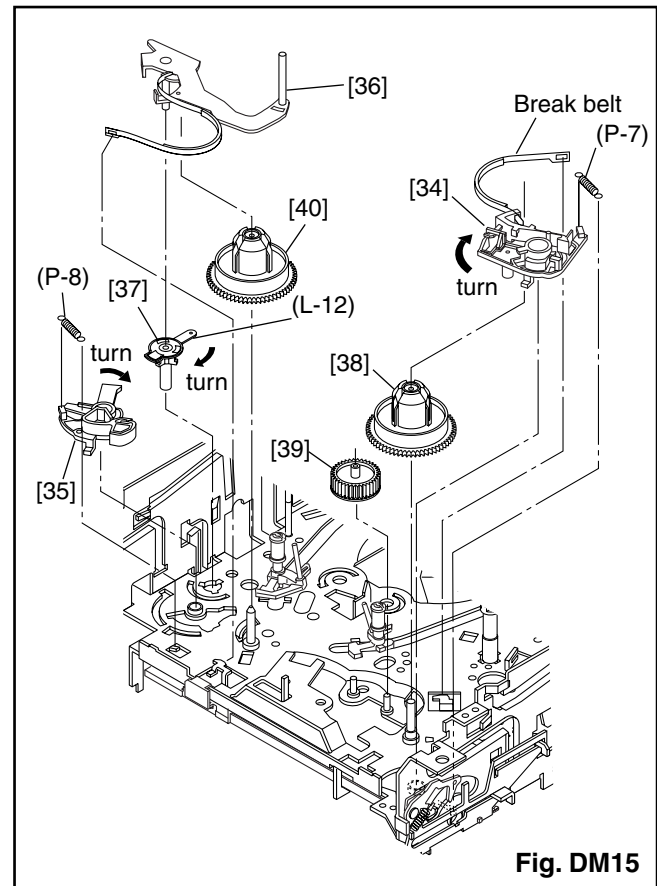




**Fig. DM13**

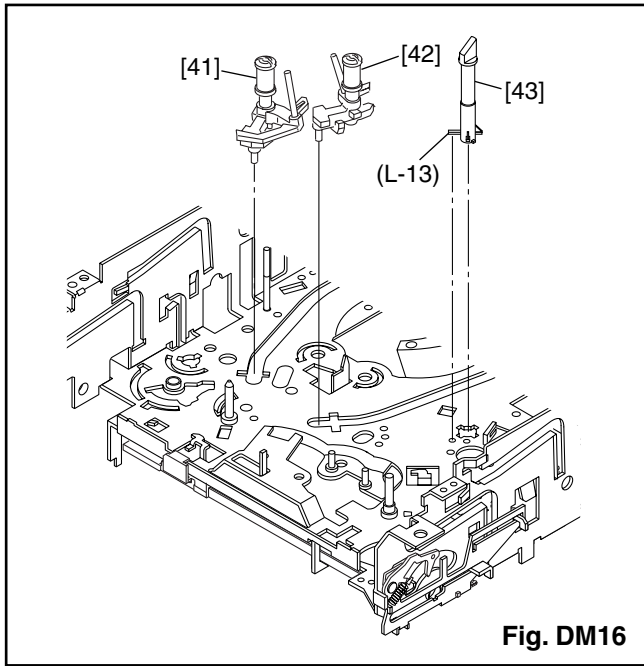


**Fig. DM14**

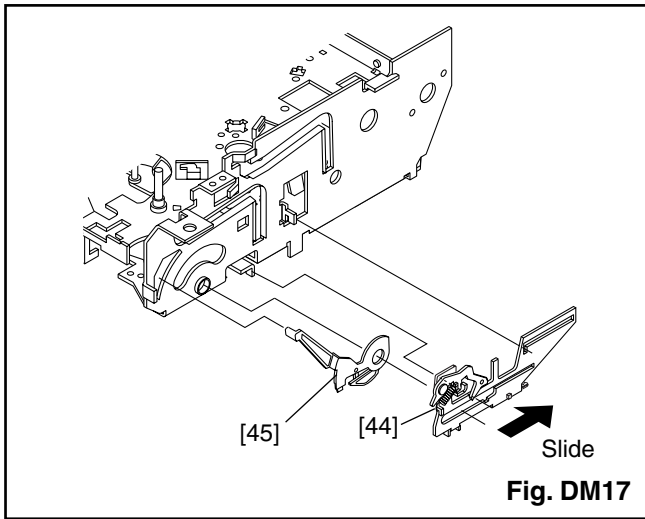


**Fig. DM15**





**Fig. DM16**



**Fig. DM17**

# 5-3 ALIGNMENT PROCEDURES OF MECHANISM

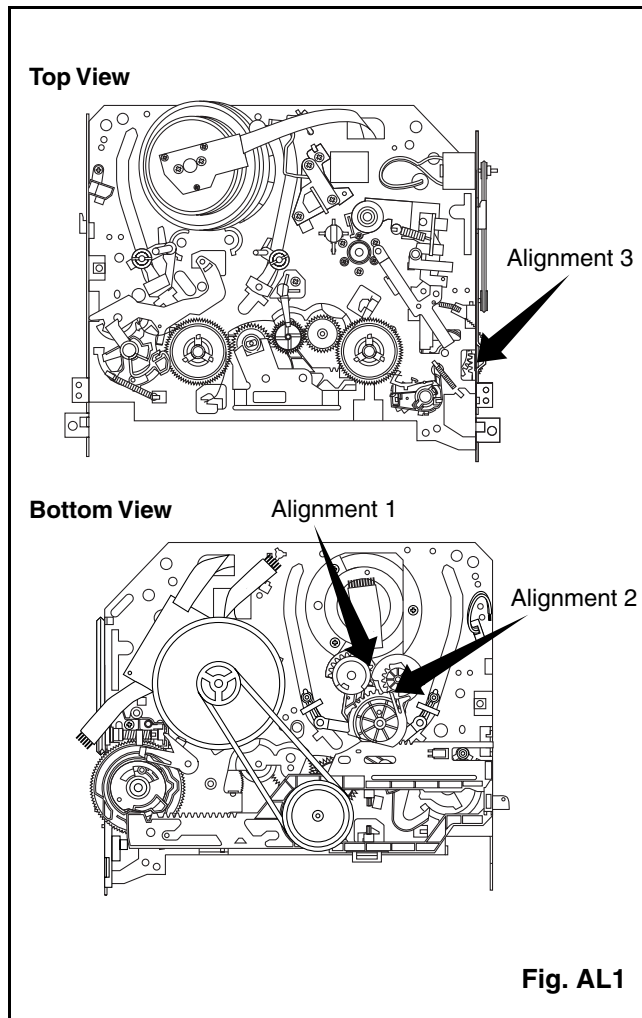
The following procedures describe how to align the individual gears and levers that make up the tape loading/unloading mechanism. Since information about the state of the mechanism is provided to the System Control Circuit only through the Mode Switch, it is essential that the correct relationship between individual gears and levers be maintained.

**All alignments are to be performed with the mechanism in Eject mode,** in the sequence given. Each procedure assumes that all previous procedures have been completed.

**IMPORTANT:**

If any one of these alignments is not performed properly, even if off by only one tooth, the unit will unload or stop and it may result in damage to the mechanical or electrical parts.

**Alignment points in Eject Position**



Alignment 1

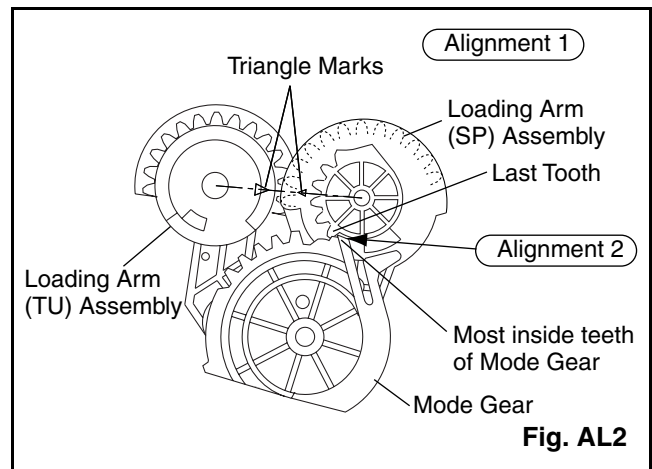
**Loading Arm (SP) and (TU) Assembly**

Install Loading Arm (SP) and (TU) Assembly so that their triangle marks point to each other as shown in Fig. AL2.

Alignment 2

**Mode Gear**

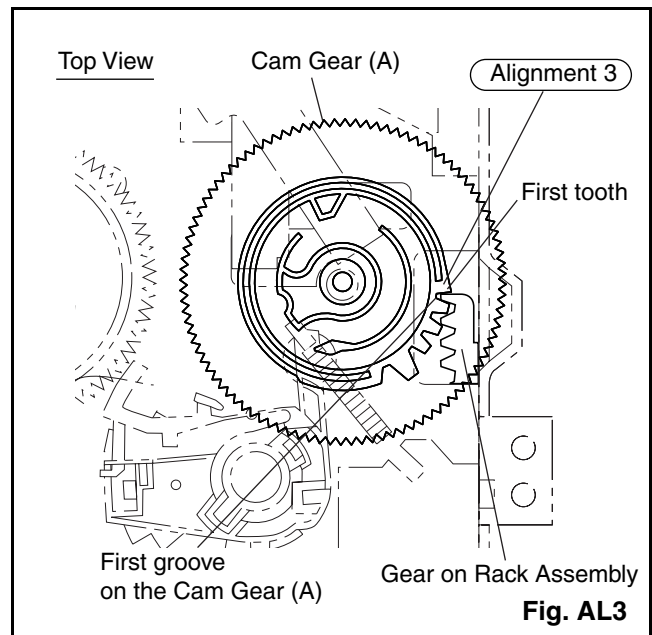
Keeping the two triangles pointing at each other, install the Loading Arm (TU) Assembly so that the last tooth of the gear meets the most inside teeth of the Mode Gear. See Fig. AL2.



Alignment 3

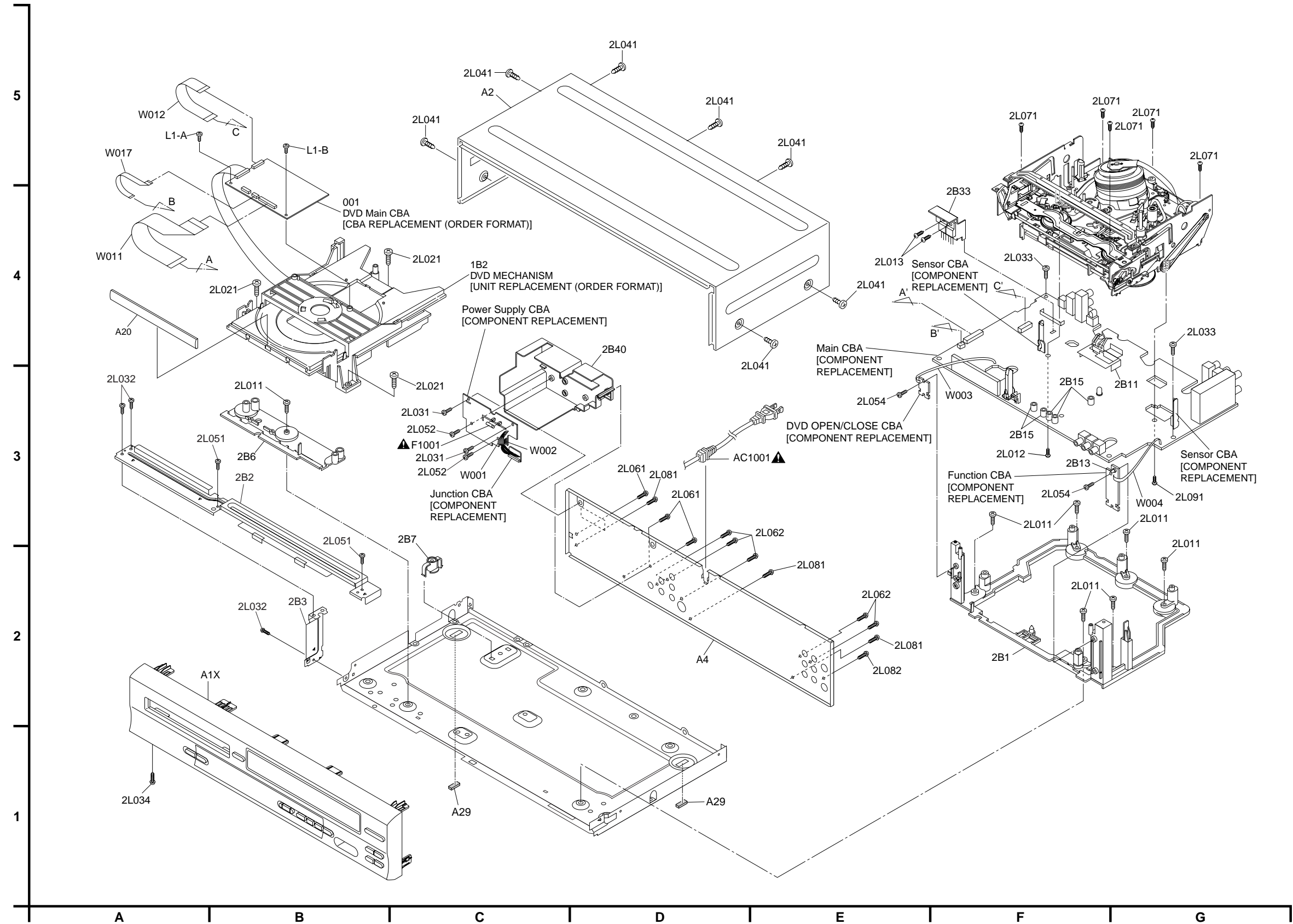
**Cam Gear (A), Rack Assembly**

Install the Rack Assembly so that the first tooth on the gear of the Rack Assembly meets the first groove on the Cam Gear (A) as shown in Fig. AL3.

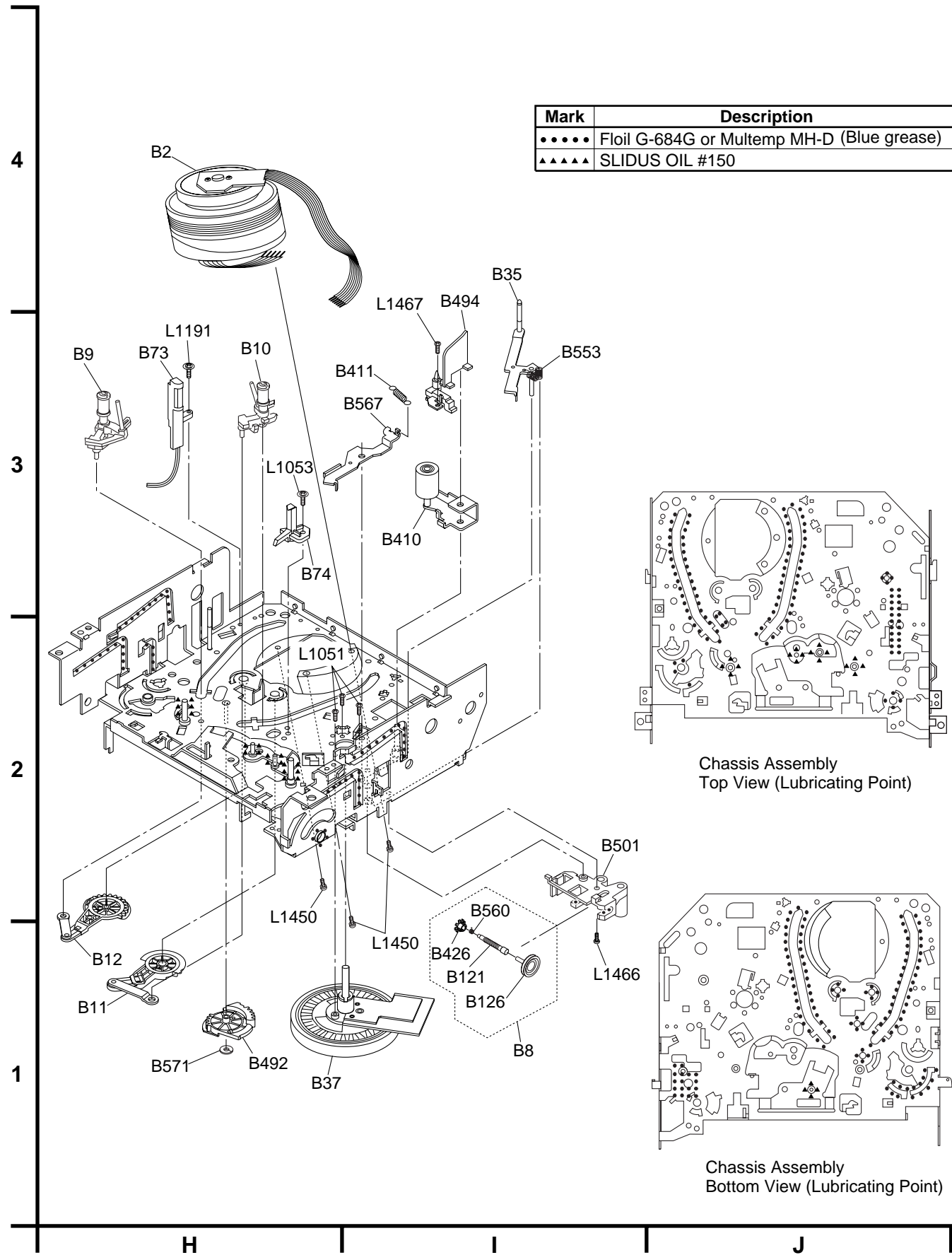


### 6-1 EXPLODED VIEWS

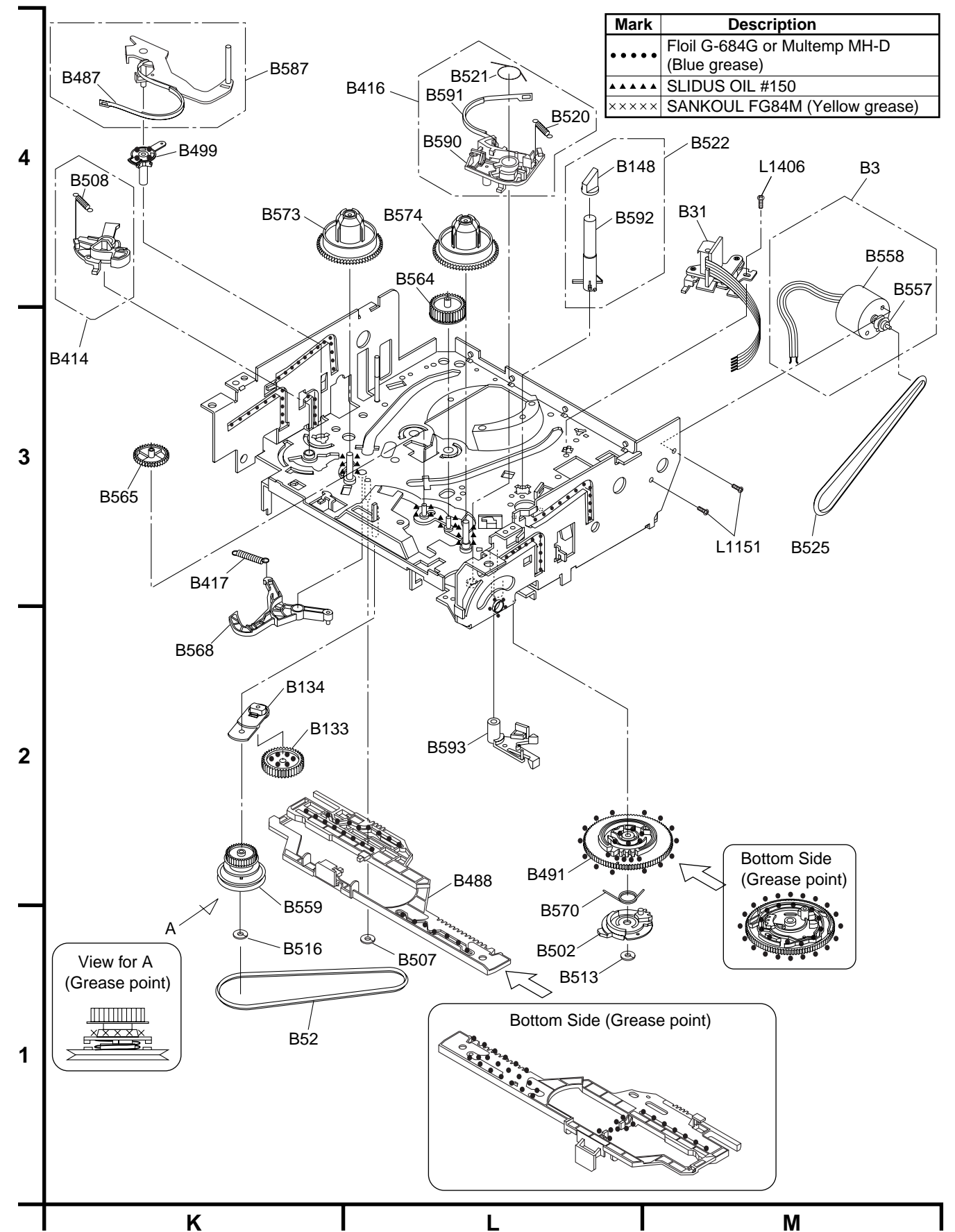
#### 6-1-1 Cabinet Section



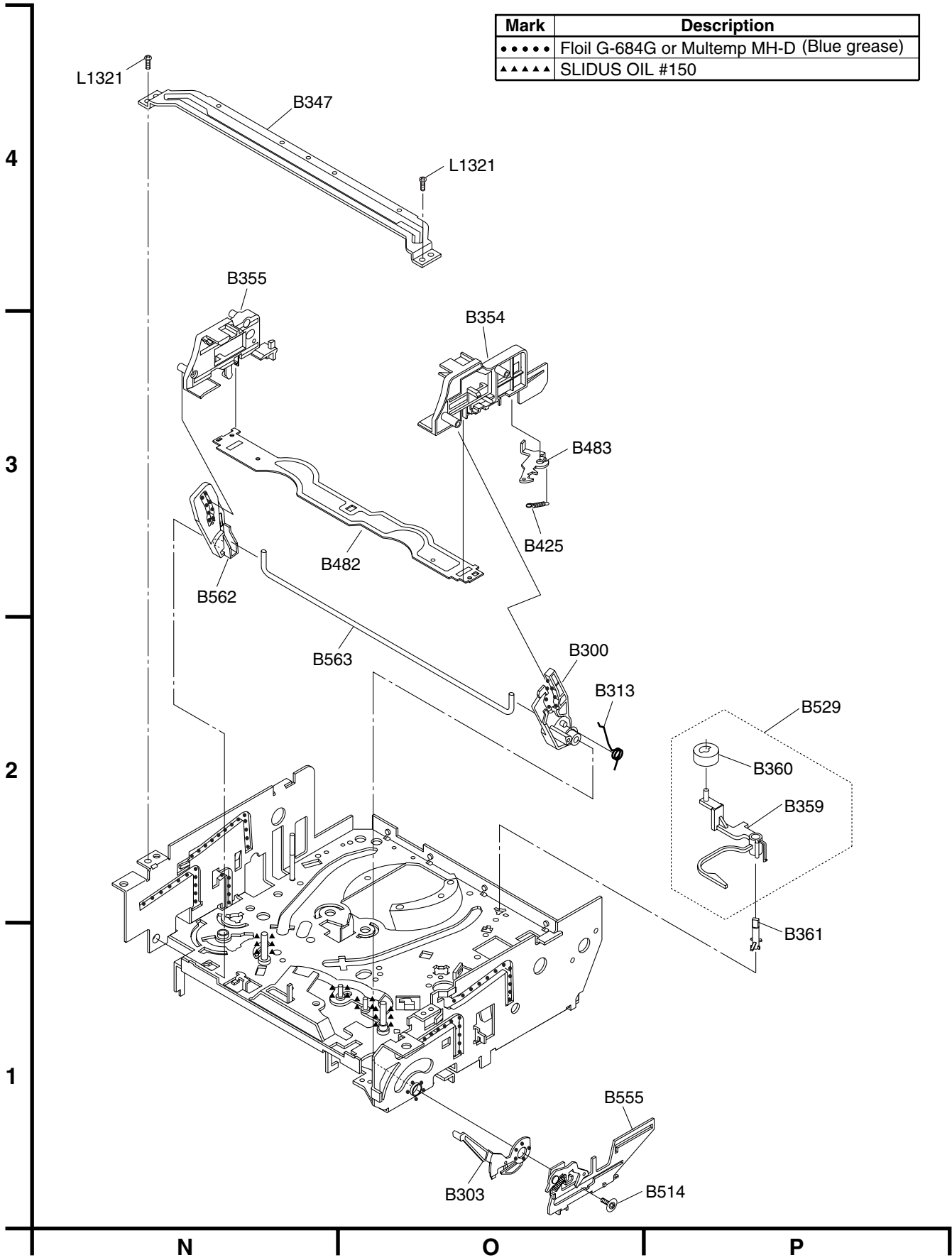
### 6-1-2 Deck Mechanism View 1 Section



### 6-1-3 Deck Mechanism View 2 Section



# 6-1-4 Deck Mechanism View 3 Section



Mark	Description
•••••	Floil G-684G or Multemp MH-D (Blue grease)
▲▲▲▲▲	SLIDUS OIL #150

4

3

2

1

N

O

P

# 6-2 REPLACEMENT PARTS LIST

## 6-2-1 Mechanical Parts List

SYMBOL-NO	P-NO	DESCRIPTION	SYMBOL-NO	P-NO	DESCRIPTION
<b>MECHANISM SECTION</b>			B31	TS18415	AC HEAD ASSEMBLY
			B35	TS18416	TAPE GUIDE ARM ASSEMBLY
A1X	TS18401	FRONT ASSEMBLY [DV-PF33U]	B37	TS18417	CAPSTAN MOTOR
A1X	TS18402	FRONT ASSEMBLY [DV-PF73U/PF73U(C)]	B52	TJ15161	CAP BELT
A2	TS18403	TOP COVER(BLACK) [DV-PF33U]	B73	TS17499	FE HEAD ASSEMBLY
A2	TS18404	TOP COVER [DV-PF73U/PF73U(C)]	B74	TJ15163	PRISM
A4	TJ16871	PANEL REAR [DV-PF33U]	B121	TJ16896	WORM
A4	TJ16872	PANEL REAR [DV-PF73U]	B126	TJ16897	PULLEY
A4	TJ16873	PANEL REAR [DV-PF73U(C)]	B133	TJ16898	IDLER GEAR
A20	TJ16874	PANEL TRAY [DV-PF33U]	B134	TJ16899	IDLER ARM
A20	TJ16875	PANEL TRAY [DV-PF73U/PF73U(C)]	B148	TJ15984	TG CAP
A29	TJ15943	FOOT	B300	TJ16901	CASSETTE DRIVE LEVER(TU)
▲ AC1001	TE14761	AC CORD	B303	TJ16902	F DOOR OPENER
1B1	TS18405	DVD MECHA	B313	TJ16903	CASSETTE DRIVE SPRING
2B1	TJ16876	DECK PEDESTAL-1	B347	TJ15987	GUIDE HOLDER A
2B2	TJ16877	TOP BRACKET	B354	TJ16904	SLIDER(TU)
2B3	TJ15946	SIDE BRACKET	B355	TJ16905	SLIDER(SP)
2B6	TJ16878	DECK PEDESTAL-2	B359	TJ15103	CLEANER LEVER
2B7	TJ16879	DECK PEDESTAL-3	B360	TJ15104	CLEANER ROLLER
2B11	TS17391	SHIELD ASSEMBLY	B361	TJ15105	CL POST
2B13	TE13012	BUSH, LED(E)	B410	TS18418	PINCH ARM ASSEMBLY
2B15	TJ15122	BUSH, LED(F)	B411	TJ16906	PINCH SPRING
2B33	TJ16891	HEATSINK	B414	TS18419	M BRAKE(SP) ASSEMBLY
2B40	TJ16881	INSULATOR	B416	TS18421	M BRAKE(TU) ASSEMBLY
2L011	TJ15952	SCREW, S 3X8	B417	TJ16907	TENSION SPRING
2L012	TJ15956	SCREW, S M3X8	B425	TJ15185	LOCK LEVER SPRING
2L013	TJ15956	SCREW, S M3X8	B426	TJ15186	KICK PULLEY
2L021	TJ16882	SCREW, S M3X26	B482	TJ16908	CASSETTE PLATE
2L031	TJ15955	SCREW, S M3X5	B483	TJ16909	LOCK LEVER
2L032	TJ15955	SCREW, S M3X5	B487	TJ16911	BAND BRAKE(SP)
2L033	TJ15955	SCREW, S M3X5	B488	TJ16912	MODE LEVER
2L034	TJ10176	SCREW, S M3X6	B491	TJ16913	CAM GEAR(A)
2L041	TJ15891	SCREW, C M3X5 [DV-PF33U]A	B492	TJ16914	MODE GEAR
2L041	TJ16023	SCREW, C M3X5 [DV-PF73U/PF73U(C)]	B494	TJ16915	CASSETTE DOOR OPENER
2L051	TJ14057	SCREW, P M3X6	B499	TJ16916	T LEVER HOLDER
2L052	TJ14057	SCREW, P M3X6	B501	TJ16917	WORM HOLDER
2L054	TJ14057	SCREW, P M3X6	B502	TJ16918	CAM GEAR(B)
2L061	TJ15892	SCREW, B M3X8	B507	TJ14034	REEL WASHER
2L062	TJ15892	SCREW, B M3X8	B508	TJ15199	BRAKE SPRING (S)
2L071	TJ10119	SCREW, P M3X10	B513	TJ16919	CAM WASHER
2L081	TJ16883	SCREW, S M3X5	B514	TJ15202	SCREW RACK
2L082	TJ16883	SCREW, S M3X5	B516	TJ14034	REEL WASHER
2L091	TJ15954	SCREW, P M3X8	B520	TJ16921	TU BRAKE SPRING
B2	TS18412	CYLINDER ASSEMBLY	B521	TJ16922	REV BRAKE SPRING
B3	TS18413	LOADING MOTOR ASSEMBLY	B522	TS17454	TG POST ASSEMBLY
B8	TS18414	PULLEY ASSEMBLY	B525	TJ16001	LDG BELT
B9	TJ16892	MOVING GUIDE (S) PREPARATION	B529	TJ15106	CLEANER ASSEMBLY
B10	TJ16893	MOVING GUIDE (T) PREPARATION	B553	TJ16003	REV SPRING
B11	TJ16894	LOADING ARM(TU) ASSEMBLY	B555	TS18422	RACK ASSEMBLY
B12	TJ16895	LOADING ARM(SP) ASSEMBLY	B557	TJ15215	MOTOR PULLEY

SYMBOL-NO	P-NO	DESCRIPTION	SYMBOL-NO	P-NO	DESCRIPTION
B558	TJ16923	LOADING MOTOR			
B559	TS18423	CLUTCH ASSEMBLY			
B560	TJ15303	KICK SPRING			
B562	TJ16924	CASSETTE DRIVE LEVER(SP)			
B563	TJ16925	SLIDER SHAFT			
B564	TJ16926	M GEAR			
B565	TJ16927	SENSOR GEAR			
B567	TJ16928	PINCH ARM(B)			
B568	TJ16929	BT ARM			
B570	TJ16035	CAM RACK SPRING(HI)			
B571	TJ15203	WASHER			
B573	TJ16931	REEL(SP)(D2)			
B574	TJ16932	REEL(TU)(D2)			
B587	TS18424	TENSION LEVER ASSEMBLY			
B589	TJ16933	TENSION LEVER			
B590	TJ16934	BRAKE ARM(TU)			
B591	TJ16935	BAND BRAKE(TU)			
B592	TJ16936	TG POST			
B593	TS18425	CAM HOLDER(F) ASSEMBLY			
B594	TJ16937	M BRAKE S			
L1051	TJ14055	SCREW, B M2.6X6			
L1053	TJ15313	SCREW, S M2.6X8			
L1151	TJ15236	SCREW, SEMS M2.6X4			
L1191	TJ15313	SCREW, S M2.6X8			
L1321	TJ10176	SCREW, S M3X6			
L1406	TJ15238	AC HEAD SCREW			
L1450	TE12971	SCREW, SEMS M2.6X5			
L1466	TJ14066	SCREW, S M2.6X6			
L1467	TJ15958	SCREW, S M2.6X5			
L1-A	TJ10177	SCREW 3X8			
L1-B	TJ10177	SCREW 3X8			
001	TS18408	DVD Main CBA			
<b>ACCESSORIES</b>					
X1	TS18321	REMOTE CONTROL UNIT [DV-PF33U]			
X1	TS18351	REMOTE CONTROL UNIT [DV-PF73U/PF73U(C)]			
X3	5857952	RF CABLE			
X5	TE14751	AV CORD			

## 6-2-2 Electrical Parts List

**Note:** Although some parts in the schematic diagrams have different names from those in the parts list, there is no problem in replacing parts.

SYMBOL-NO	P-NO	DESCRIPTION	SYMBOL-NO	P-NO	DESCRIPTION
<b>SEMI-CONDUCTORS</b>			▲ IC1001	TE13224	PHOTOCOUPLER LTV-817B-F
D013	TC10791	RECTIFIER DIODE BA157	IC1002	TC12682	VOLTAGE REGULATOR PQ070XF01SZ
D016	TJ14082	SCHOTTKY BARRIER DIODE SB340	IC1004	TC12682	VOLTAGE REGULATOR PQ070XF01SZ
D018	TJ14691	ZENER DIODE MTZJT-778.2A	IC1006	TC12241	IC KIA431-AT
D019	TC12691	RECTIFIER DIODE RL201	IC1201	TC12251	IC KIA4558P
D030	TC10791	RECTIFIER DIODE BA157	IC1402	TC12683	DRIVER FOR DVD MM1622XJBE
D052	TJ13919	ZENER DIODE MTZJT-7710B	Q052	TC12591	TRANSISTOR KRC103M
D080	TC10752	RECTIFIER DIODE 1N4005	Q055	TJ13924	TRANSISTOR 2SC536NF-NPA-AT
D081	TC10752	RECTIFIER DIODE 1N4005	Q056	TJ15283	TRANSISTOR 2SC2001(K)
D100	TC10112	SWITCHING DIODE 1SS133(T-77)	Q057	TE13243	TRANSISTOR KTC3199(BL)
D101	TC10112	SWITCHING DIODE 1SS133(T-77)	Q301	TC10784	TRANSISTOR KTA1266(GR)
D501	TC10112	SWITCHING DIODE 1SS133(T-77)	Q302	TC10783	TRANSISTOR KTC3193(Y)
D502	TC10112	SWITCHING DIODE 1SS133(T-77)	Q303	TC10783	TRANSISTOR KTC3193(Y)
D510	TC10112	SWITCHING DIODE 1SS133(T-77)	Q391	TC10784	TRANSISTOR KTA1266(GR)
D555	TJ13898	LED SIR-563ST3F Q	Q421	TC10784	TRANSISTOR KTA1266(GR)
D561	TJ15414	LED(RED) 204HD/E	Q422	TE13235	TRANSISTOR KTC3203(Y)
D564	TJ15414	LED(RED) 204HD/E	Q423	TJ13924	TRANSISTOR 2SC536NF-NPA-AT
D565	TJ15414	LED(RED) 204HD/E	Q424	TJ13924	TRANSISTOR 2SC536NF-NPA-AT
D566	TC12491	LED(GREEN) 204-10GD/S957	Q425	TJ13923	TRANSISTOR KRA103M
D567	TC12491	LED(GREEN) 204-10GD/S957	Q501	TE13243	TRANSISTOR KTC3199(BL)
D701	TC10607	ZENER DIODE MTZJT-7733D	Q503	TJ15141	PHOTO TRANSISTOR PT204-6B-12
D702	TC12191	ZENER DIODE DZ-6.8BSBT265	Q504	TJ15141	PHOTO TRANSISTOR PT204-6B-12
D1001	TC10752	RECTIFIER DIODE 1N4005	Q506	TJ15141	PHOTO TRANSISTOR PT204-6B-12
D1002	TC10752	RECTIFIER DIODE 1N4005	Q563	TC10778	TRANSISTOR KTC3199(Y)
D1003	TC10752	RECTIFIER DIODE 1N4005	Q565	TC10778	TRANSISTOR KTC3199(Y)
D1004	TC10752	RECTIFIER DIODE 1N4005	Q566	TC10778	TRANSISTOR KTC3199(Y)
D1007	TC12471	ZENER DIODE DZ-39BSBT265	Q567	TC10778	TRANSISTOR KTC3199(Y)
D1008	TC10877	SCHOTTKY BARRIER DIODE SB140	Q760	TC12591	TRANSISTOR KRC103M
D1010	TC10791	RECTIFIER DIODE BA157	▲ Q1001	TC12694	FET 2SK3543
D1011	TE13211	RECTIFIER DIODE BA158	Q1003	TC10778	TRANSISTOR KTC3199(Y)
D1012	TC10112	SWITCHING DIODE 1SS133(T-77)	Q1004	TE13235	TRANSISTOR KTC3203(Y)
D1016	TJ15333	RECTIFIER DIODE FR101	Q1005	TC10778	TRANSISTOR KTC3199(Y)
D1017	TC12633	ZENER DIODE DZ-20BSBT265	Q1006	TC10782	TRANSISTOR KTA1267(Y)
D1018	TC10112	SWITCHING DIODE 1SS133(T-77)	Q1008	TC10778	TRANSISTOR KTC3199(Y)
D1020	TJ14082	SCHOTTKY BARRIER DIODE SB340	Q1011	TE13235	TRANSISTOR KTC3203(Y)
D1022	TC10112	SWITCHING DIODE 1SS133(T-77)	Q1201	TC10778	TRANSISTOR KTC3199(Y)
D1024	TC10112	SWITCHING DIODE 1SS133(T-77)	Q1202	TC10778	TRANSISTOR KTC3199(Y)
D1025	TC10112	SWITCHING DIODE 1SS133(T-77)	Q1203	TC10784	TRANSISTOR KTA1266(GR)
D1035	TC10752	RECTIFIER DIODE 1N4005	Q1204	TC10784	TRANSISTOR KTA1266(GR)
D1036	TC10752	RECTIFIER DIODE 1N4005	Q1351	TC10778	TRANSISTOR KTC3199(Y)
D1037	TC10752	RECTIFIER DIODE 1N4005	Q1385	TC10778	TRANSISTOR KTC3199(Y)
D1038	TC10877	SCHOTTKY BARRIER DIODE SB140	Q2001	TC12591	TRANSISTOR KRC103M
D1058	TC10752	RECTIFIER DIODE 1N4005	<b>TRANSFORMER</b>		
D1301	TJ13895	ZENER DIODE MTZJT-775.6B	▲ T001	TE15491	SWITCHING TRANSFORMER
IC301	TJ15132	IC LA71091M	<b>COILS</b>		
IC451	TC12692	IC LA72670M	L003	TA12575	BEAD CORE
IC501	TC12693	IC MN101D08EFD1	L009	TJ13909	CHOKE COIL 47UH
IC571	TC12684	IC PT6313-S-TP	L251	5121289	INDUCTOR 22UH
IC751	TC12531	IC TC4053BF(N)			



SYMBOL-NO	P-NO	DESCRIPTION	SYMBOL-NO	P-NO	DESCRIPTION
L303	TA12561	INDUCTOR 100UH	SW513	TE11957	TACT SWITCH
L304	TJ13909	CHOKE COIL 47UH	SW514	TE11957	TACT SWITCH
L421	TJ13915	INDUCTOR 47UH	SW1401	TE11942	SLIDE SWITCH
L502	TJ13909	CHOKE COIL 47UH	SW2001	TE11957	TACT SWITCH
L503	TA12562	INDUCTOR 12UH	SW2002	TE11957	TACT SWITCH
L701	TA12563	INDUCTOR 4.7UH	SW2003	TE11957	TACT SWITCH
▲ L1001	TA14541	LINE FILTER 27MH	TU701	TS17431	TUNER UNIT TMZH2-001A
L1007	TJ13909	CHOKE COIL 47UH	VR501	TA14561	CARBON P.O.T. 100K OHM B
L1020	TJ13909	CHOKE COIL 47UH	W001	TE15492	PARALLEL WIRE, 8P
L1350	TA12561	INDUCTOR 100UH	W002	TE15493	PARALLEL WIRE, 7P
L1351	TA14481	INDUCTOR 0.47UH	W003	TE15489	PARALLEL WIRE, 2P
L1521	TJ13915	INDUCTOR 47UH	W004	TE15501	PARALLEL WIRE, 3P
L2001	TA12561	INDUCTOR 100UH	W011	TE15486	FFC CABLE, 22P
<b>CRYSTALS</b>			W012	TE15487	FFC CABLE, 18P
X301	TJ15145	X'TAL 3.579545MHZ	W017	TE15488	FFC CABLE, 4P
X502	TJ15148	X'TAL 32.768KHZ			
<b>MISCELLANEOUS</b>					
CN1001	TE15481	FMN CONNECTOR, 22P			
CN1003	TE15482	CONNECTOR, 15P			
CN1005	TE15494	CONNECTOR, 15P			
CN1601	TE14781	FMN CONNECTOR, 18P			
CN2001	TE15483	FMN CONNECTOR, 4P			
CN3001	TE15467	20P FFC			
▲ F1001	TE13223	FUSE 1A/250V			
FH1001	TE11084	FUSE HOLDER MSF-015			
FH1002	TE11084	FUSE HOLDER MSF-015			
FIP502	TE15471	V.F.D. 7-BT-292GN			
▲ GP1001	TJ13894	GAP. FNR-G3.10D			
JK751	TE15131	RCA JACK			
JK752	TE15132	RCA JACK			
JK753	TJ15136	RCA JACK(YELLOW)			
JK754	TE15495	RCA JACK(WHITE)			
JK755	TE15496	RCA JACK(RED)			
JK756	TE15133	RCA JACK			
JK1202	TE15134	RCA JACK(BLACK)			
JK1401	TE14821	S TYPE JACK			
JK1403	TE15135	RCA JACK			
RM2001	TC12331	REMOTE RECEIVER PIC-37043LU			
▲ SA1001	TC10891	SURGE ABSORBER PVR-10D471KB			
SW501	TE11957	TACT SWITCH			
SW502	TE11957	TACT SWITCH			
SW503	TE11957	TACT SWITCH			
SW504	TE11957	TACT SWITCH			
SW505	TE11957	TACT SWITCH			
SW508	TE11957	TACT SWITCH			
SW509	TE11957	TACT SWITCH			
SW511	TE15484	LEAF SWITCH			
SW512	TE15485	ROTARY MODE SWITCH			

# SCHEMATIC AND BLOCK DIAGRAMS/CBA'S

## 1 SCHEMATIC DIAGRAMS / CBA'S AND TEST POINTS

### Standard Notes

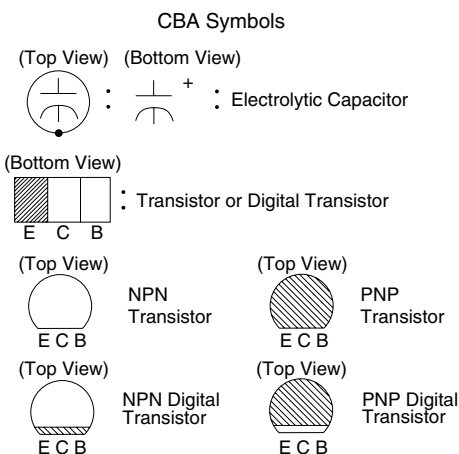
#### WARNING

Many electrical and mechanical parts in this chassis have special characteristics. These characteristics often pass unnoticed and the protection afforded by them cannot necessarily be obtained by using replacement components rated for higher voltage, wattage, etc. Replacement parts that have these special safety characteristics are identified in this manual and its supplements; electrical components having such features are identified by the mark "▲" in the schematic diagram and the parts list. Before replacing any of these components, read the parts list in this manual carefully. The use of substitute replacement parts that do not have the same safety characteristics as specified in the parts list may create shock, fire, or other hazards.

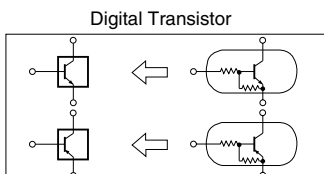
#### Capacitor Temperature Markings

Mark	Capacity change rate	Standard temperature	Temperature range
(B)	±10%	20°C	-25~+85°C
(F)	+30 - 80%	20°C	-25~+85°C
(SR)	±15%	20°C	-25~+85°C
(Z)	+30 - 80%	20°C	-10~+70°C

Capacitors and transistors are represented by the following symbols.



#### Schematic Diagram Symbols



### Notes:

1. Do not use the part number shown on these drawings for ordering. The correct part number is shown in the parts list, and may be slightly different or amended since these drawings were prepared.
2. All voltages are DC voltages unless otherwise specified.

### Values in schematic diagrams

The values, dielectric strength ( power capacitance ) and tolerances of the resistors ( excluding variable resistors ) and capacitors are indicated in the schematic diagrams using abbreviations.

#### [ Resistors ]

Item	Indication
Value	No indication.....Ω K.....kΩ M.....MΩ
Power capacitance	No indication.....1/4W,1/6W All capacitances other than the above are indicated in schematic diagrams.

#### [ Capacitors ]

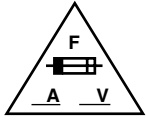
Item	Indication
Value	No indication.....μF P.....pF
Dielectric strength	No indication.....50V All dielectric strengths other than 50V are indicated in schematic diagrams.

#### [ Coils ]

Item	Indication
Value	μ.....μH m.....mH

**LIST OF CAUTION, NOTES, AND SYMBOLS USED IN THE SCHEMATIC DIAGRAMS ON THE FOLLOWING PAGES:**

**1. CAUTION:**



FOR CONTINUED PROTECTION AGAINST FIRE HAZARD, REPLACE ONLY WITH THE SAME TYPE FUSE.  
 ATTENTION: POUR UNE PROTECTION CONTINUE LES RISQUES D'INCELE N'UTILISER QUE DES FUSIBLE DE MEMO TYPE.  
 RISK OF FIRE-REPLACE FUSE AS MARKED.



This symbol means fast operating fuse.  
 Ce symbole représente un fusible à fusion rapide.

**2. CAUTION:**

Fixed Voltage (or Auto voltage selectable) power supply circuit is used in this unit.  
 If Main Fuse (F1001) is blown, first check to see that all components in the power supply circuit are not defective before you connect the AC plug to the AC power supply. Otherwise it may cause some components in the power supply circuit to fail.

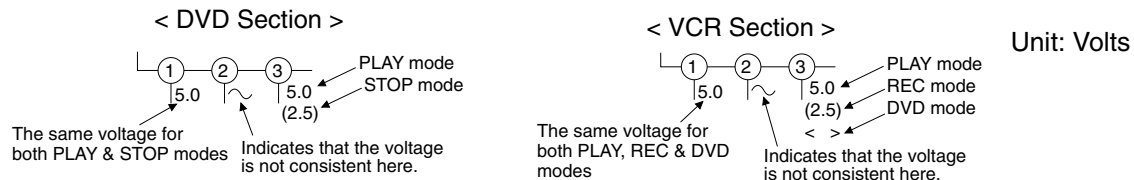
**3. Note:**

- (1) Do not use the part number shown on the drawings for ordering. The correct part number is shown in the parts list, and may be slightly different or amended since the drawings were prepared.
- (2) To maintain original function and reliability of repaired units, use only original replacement parts which are listed with their part numbers in the parts list section of the service manual.

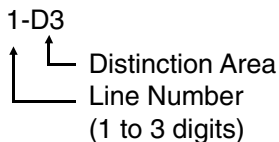
**4. Wire Connectors**

- (1) Prefix symbol "CN" means "connector" (can disconnect and reconnect).
- (2) Prefix symbol "CL" means "wire-solder holes of the PCB" (wire is soldered directly).

**5. Voltage indications for PLAY and REC modes on the schematics are as shown below:**

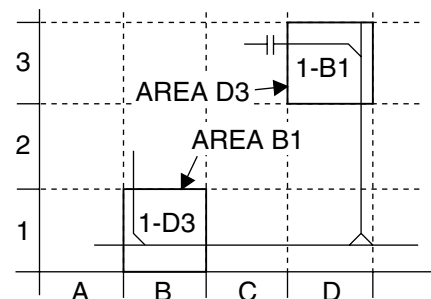


**6. How to read converged lines**



Examples:

1. "1-D3" means that line number "1" goes to area "D3".
2. "1-B1" means that line number "1" goes to area "B1".

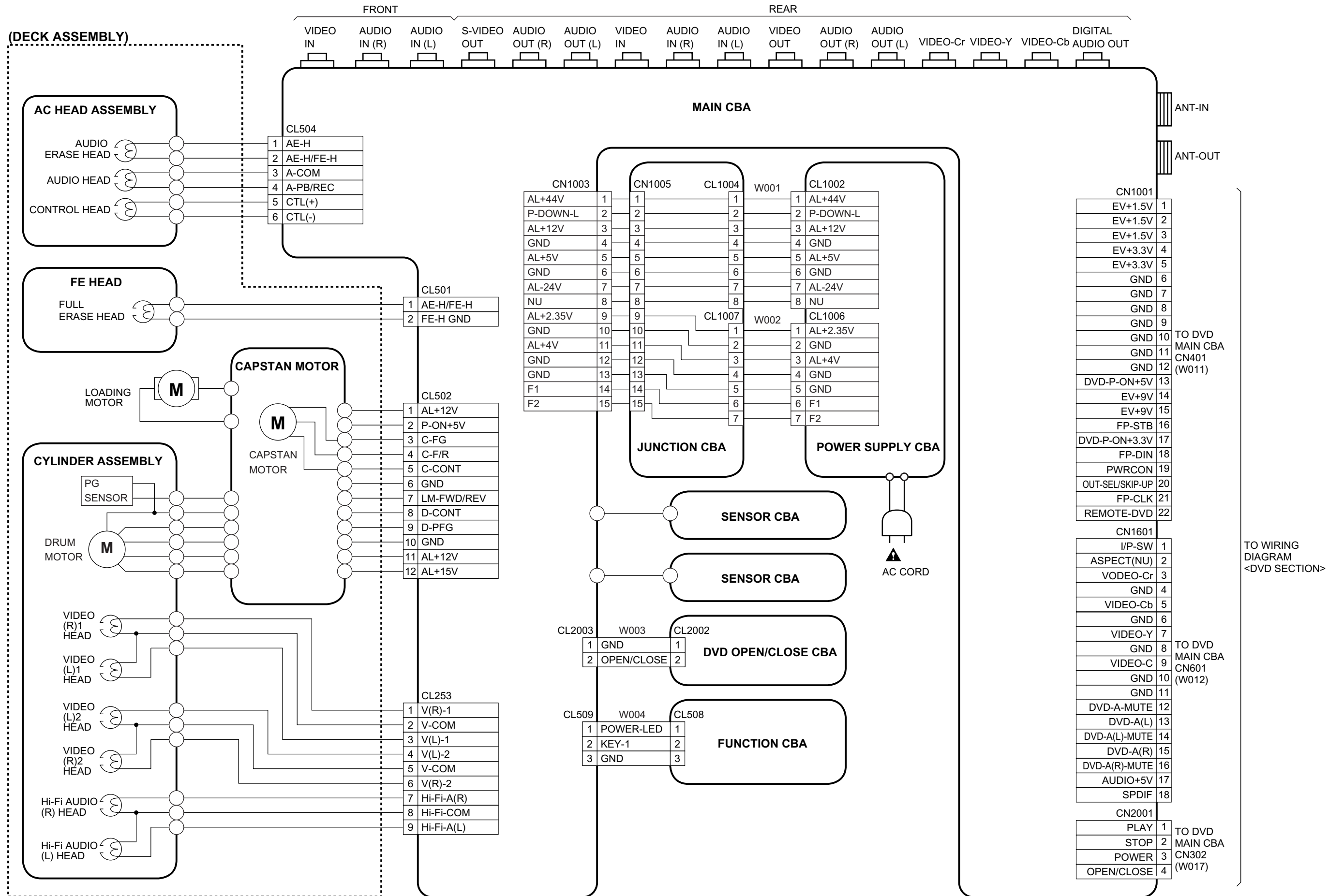


**7. Test Point Information**

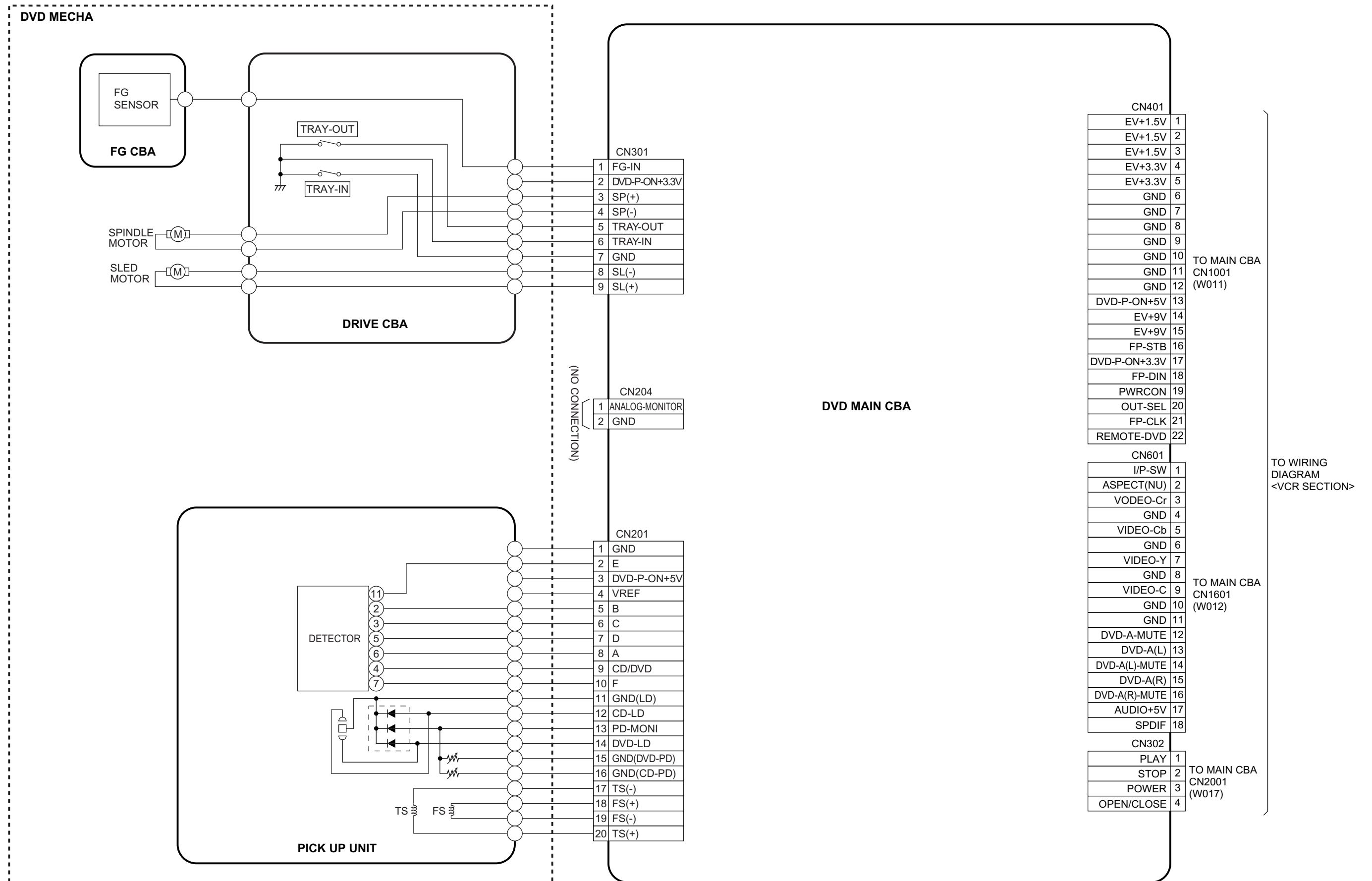
- : Indicates a test point with a jumper wire across a hole in the PCB.
- : Used to indicate a test point with a component lead on foil side.
- : Used to indicate a test point with no test pin.
- : Used to indicate a test point with a test pin.

# 2 WIRING DIAGRAMS

## 2-1 VCR Section

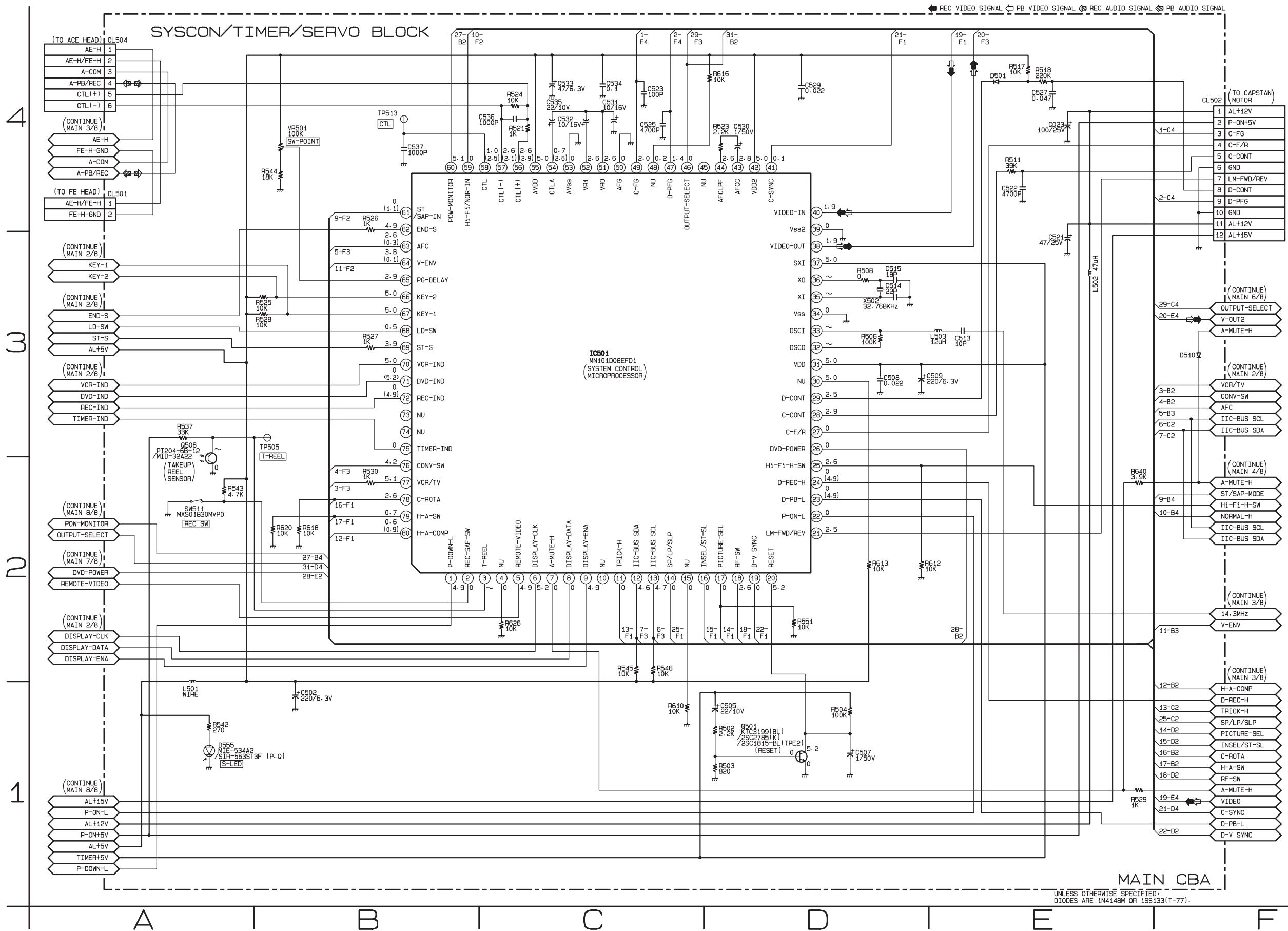


## 2-2 DVD Section



# 3 SCHEMATIC DIAGRAMS

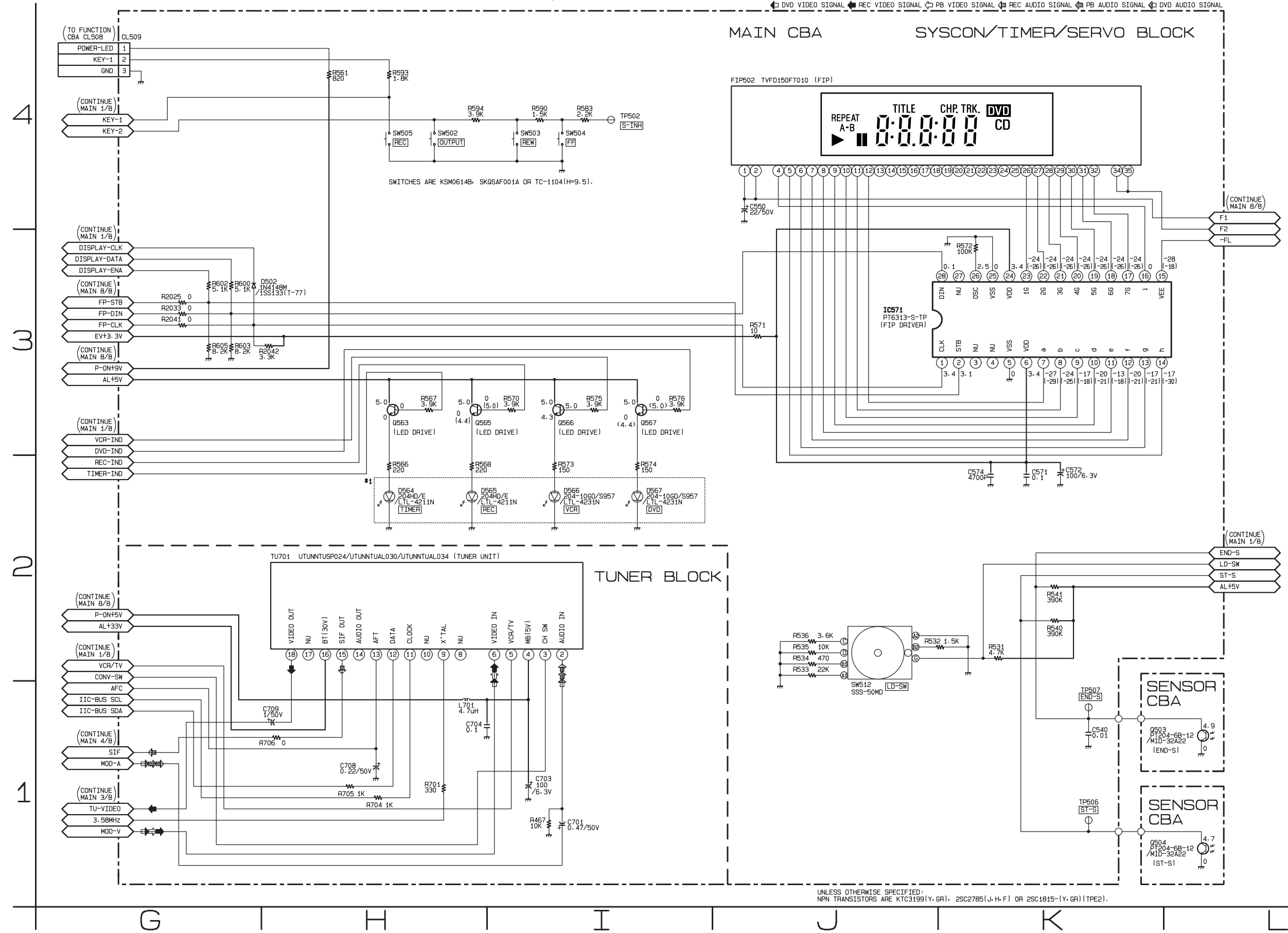
## 3-1 Main 1/8 Schematic Diagram



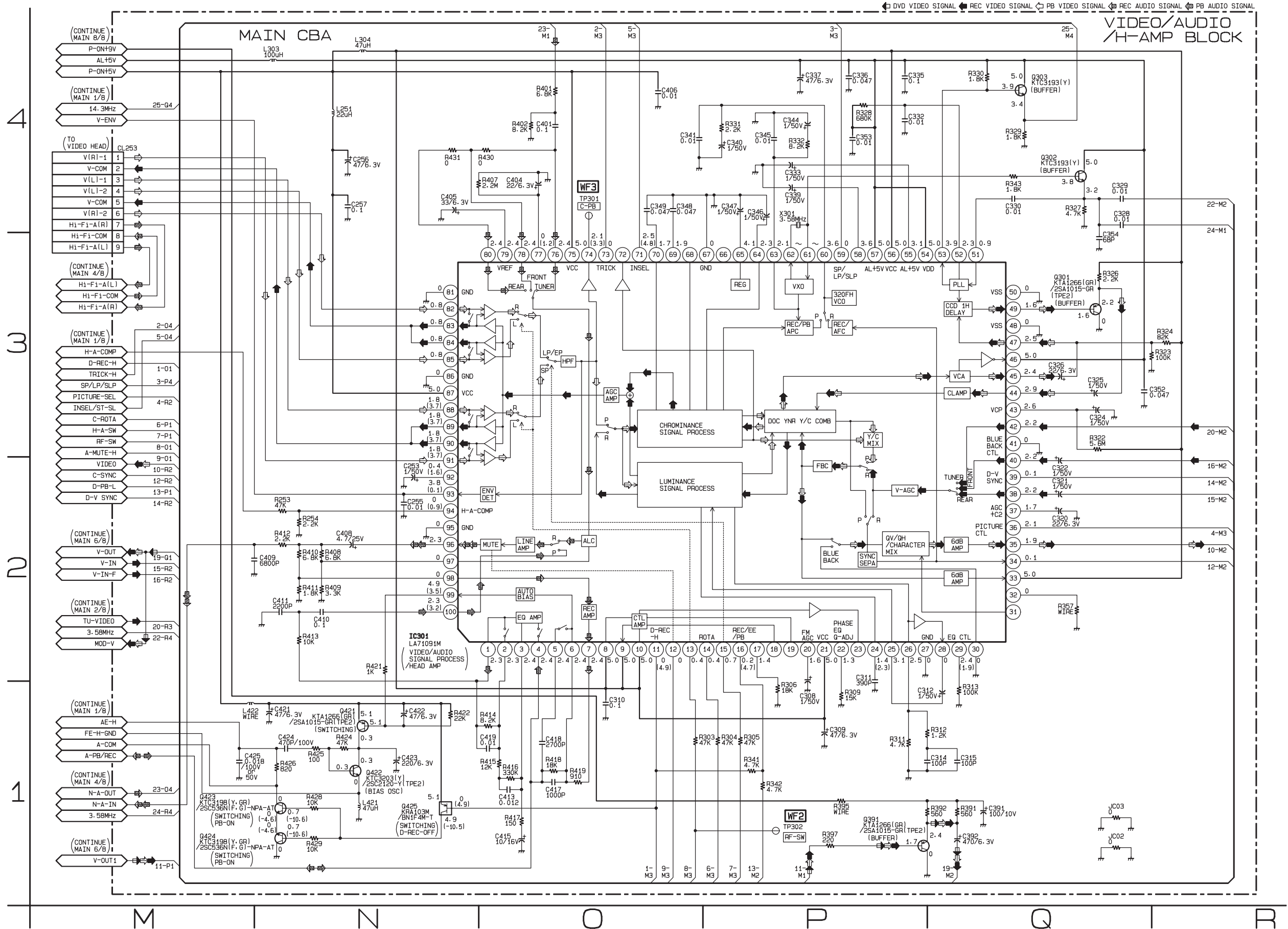
### 3-2 Main 2/8 & Sensor Schematic Diagrams

\*1 Note:

When it is necessary to replace one or more of the following Diodes, all four should be replaced: D564, D565, D566, D567.

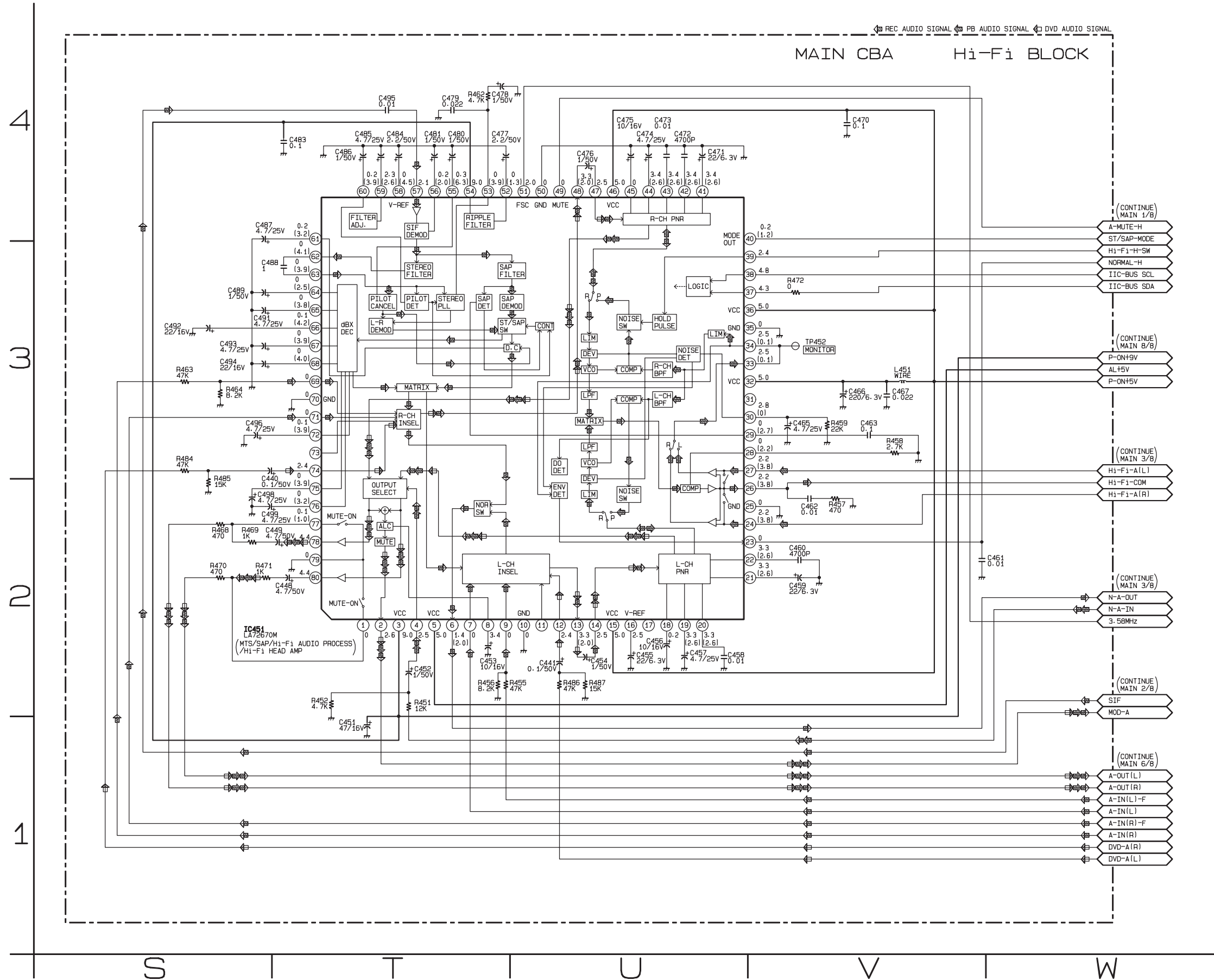


### 3-3 Main 3/8 Schematic Diagram

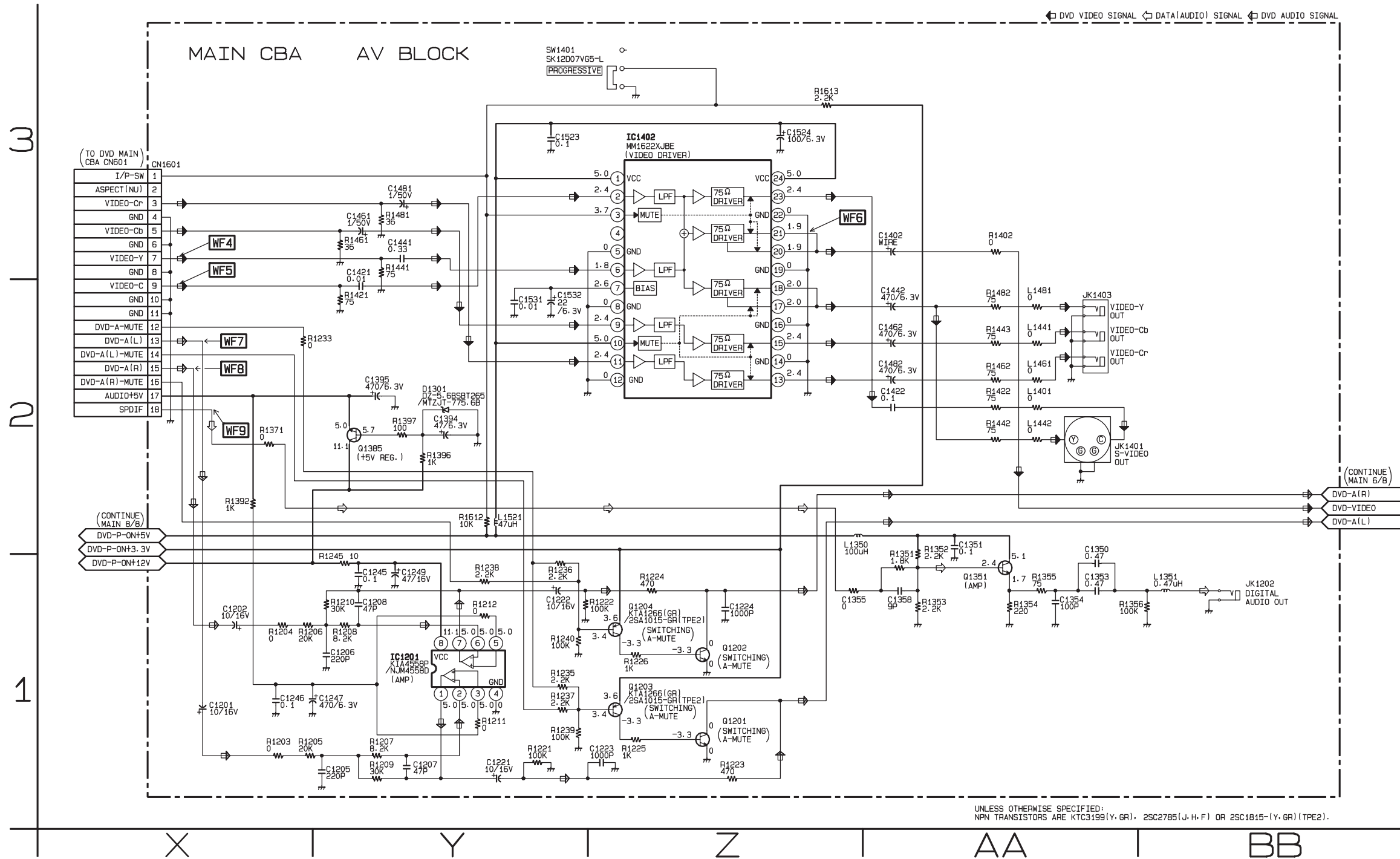




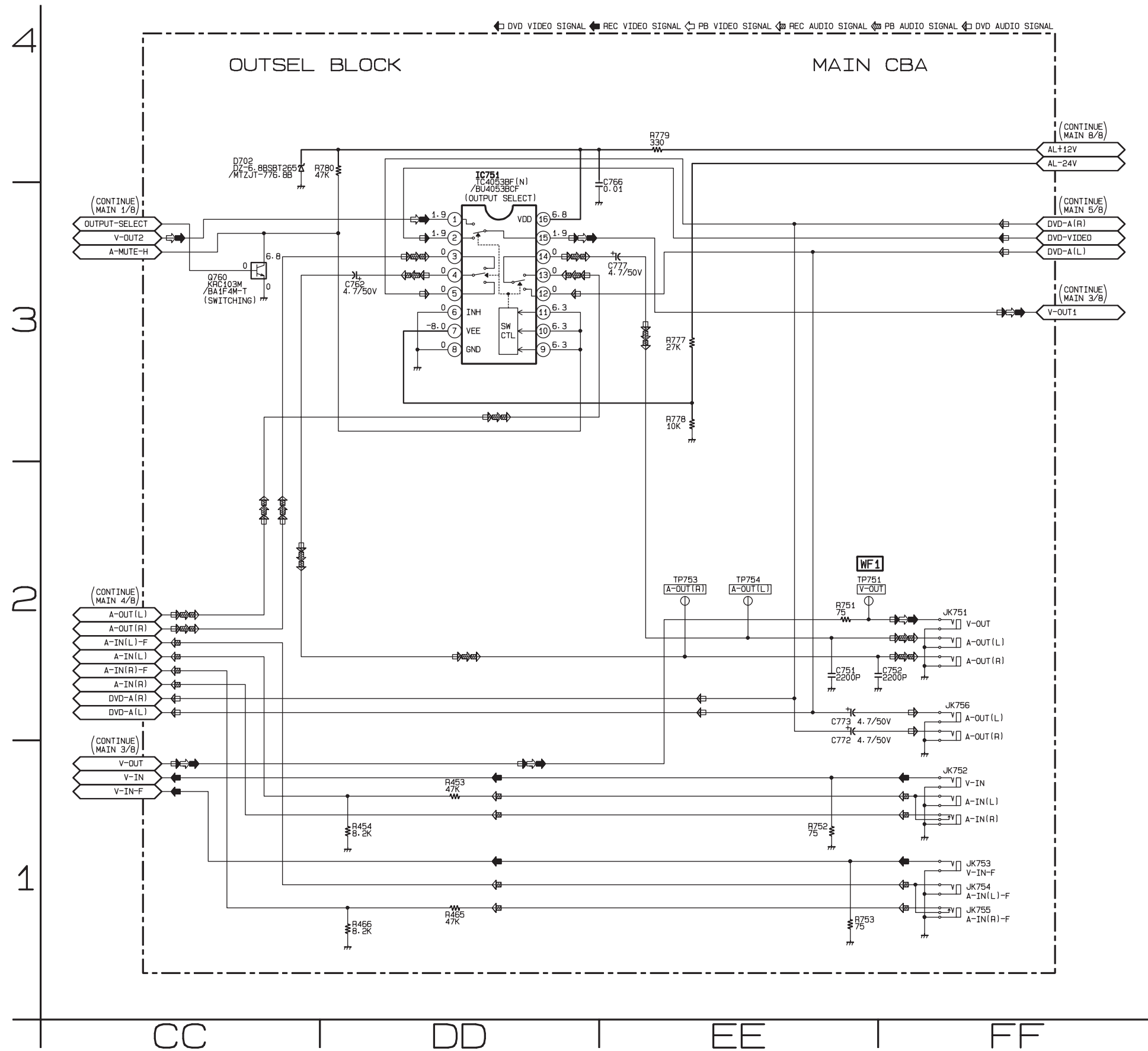
### 3-4 Main 4/8 Schematic Diagram



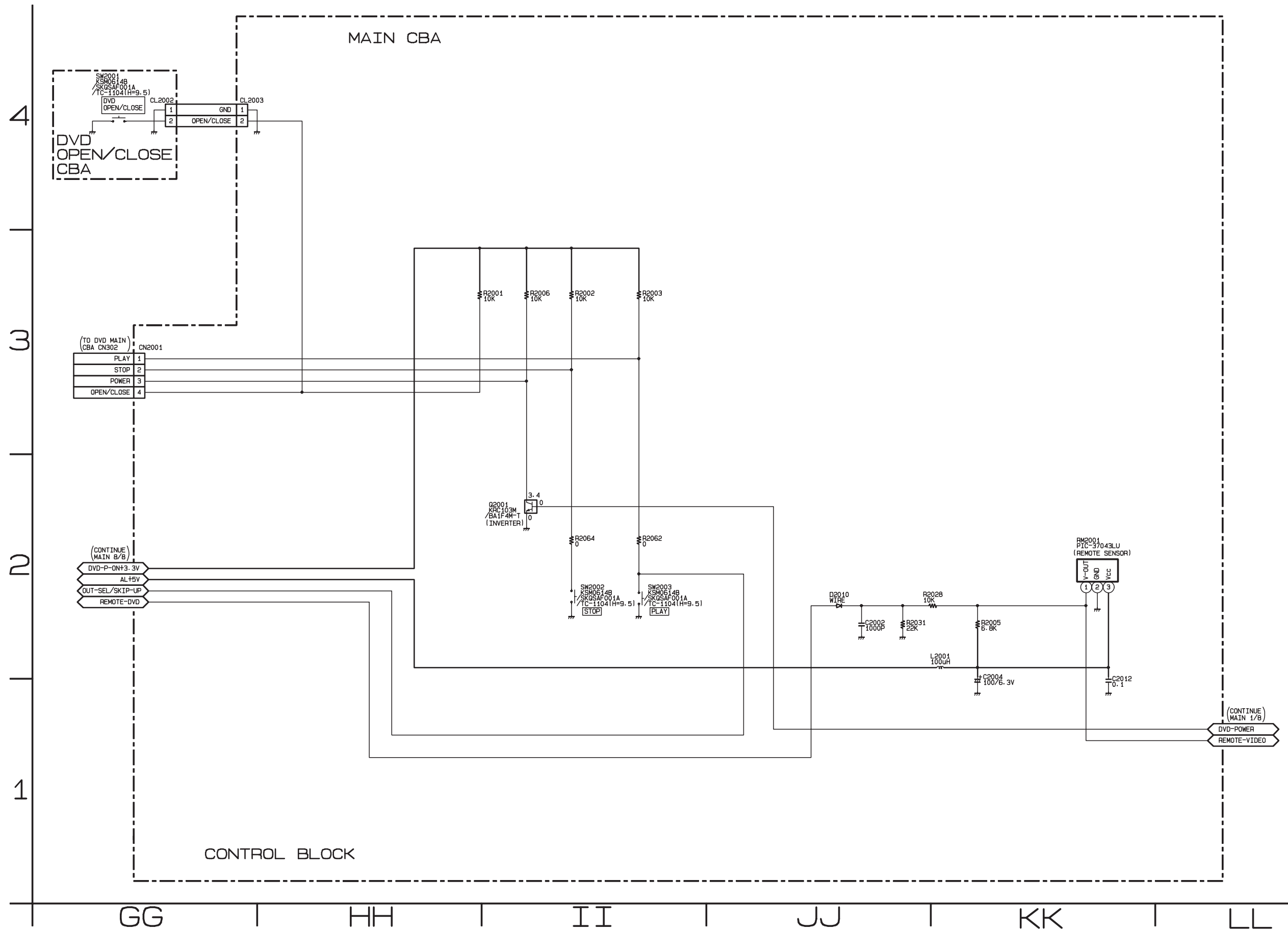
### 3-5 Main 5/8 Schematic Diagram



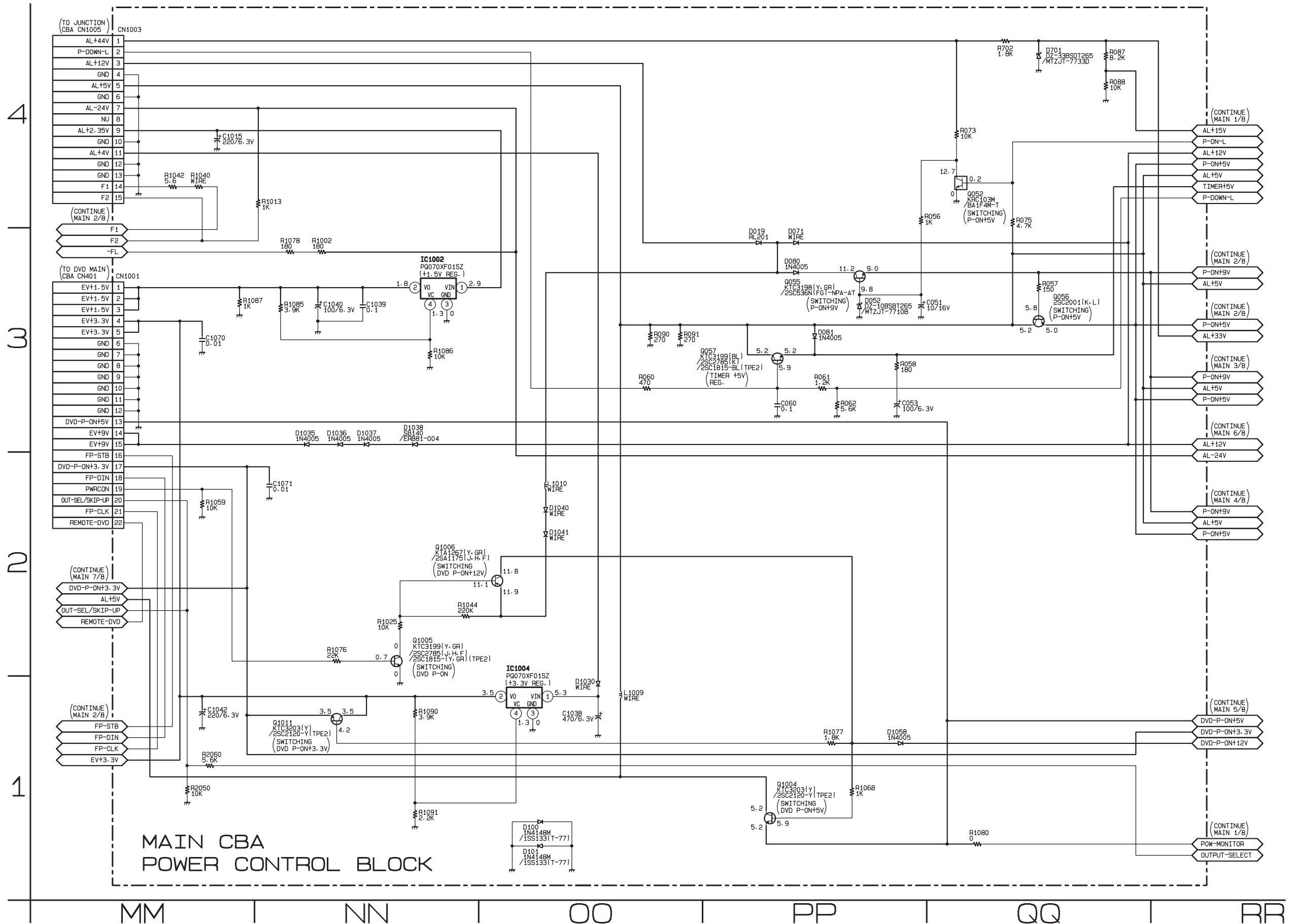
### 3-6 Main 6/8 Schematic Diagram



### 3-7 Main 7/8 & DVD OPEN/ CLOSE Schematic Diagrams



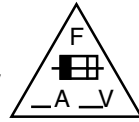
### 3-8 Main 8/8 Schematic Diagram



### 3-9 Power Supply & Junction Schematic Diagrams

**CAUTION !**

Fixed voltage ( or Auto voltage selectable ) power supply circuit is used in this unit.  
 If Main Fuse (F1001) is blown, check to see that all components in the power supply circuit are not defective before you connect the AC plug to the AC power supply.  
 Otherwise it may cause some components in the power supply circuit to fail.



**CAUTION**

FOR CONTINUED PROTECTION AGAINST FIRE HAZARD,  
 REPLACE ONLY WITH THE SAME TYPE FUSE.  
 ATTENTION : POUR UNE PROTECTION CONTINUE LES RISQUES  
 D'INCELE N'UTILISER QUE DES FUSIBLE DE MÊME TYPE.

**RISK OF FIRE-REPLACE FUSE AS MARKED.**

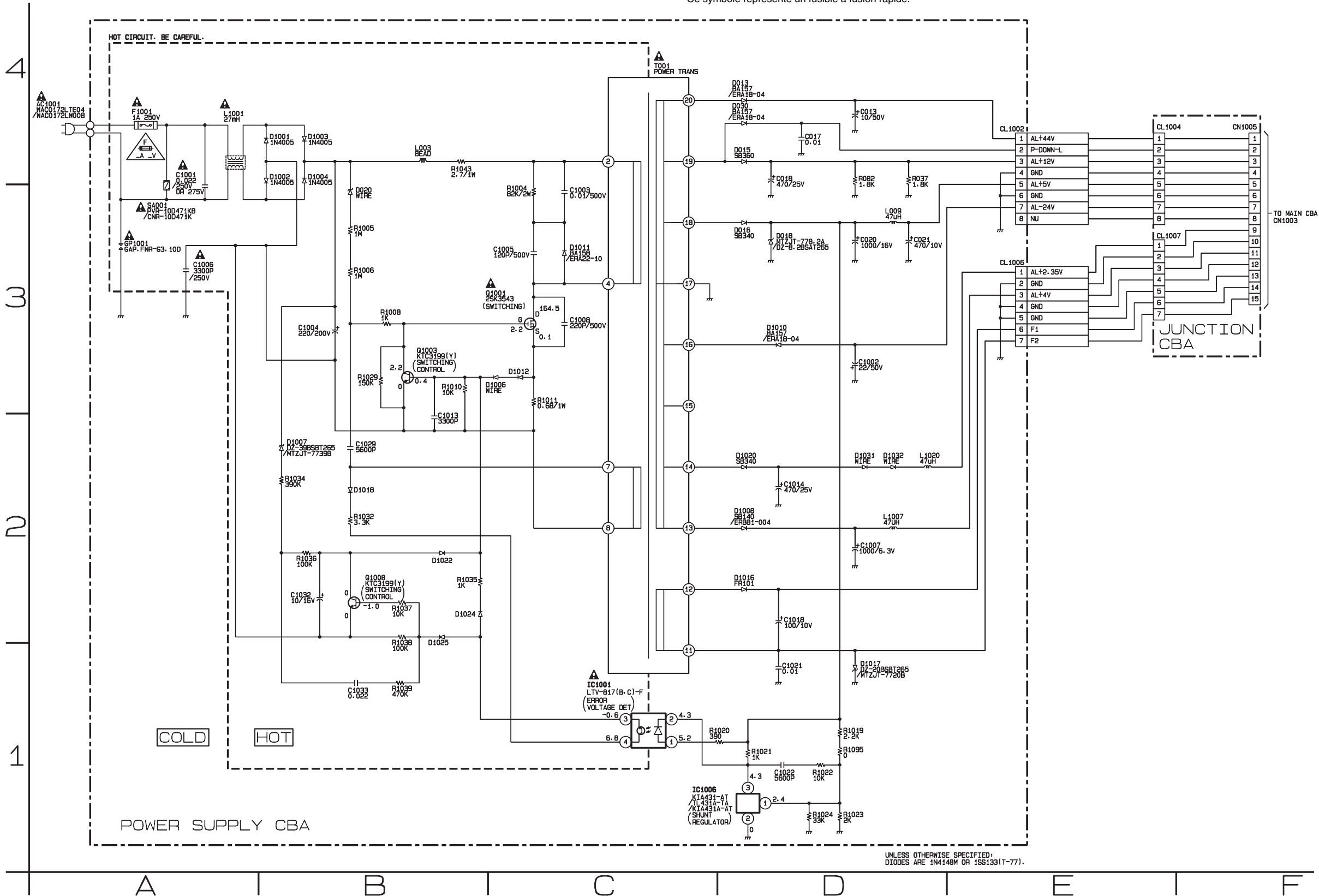


"This symbol means fast operating fuse."

"Ce symbole représente un fusible à fusion rapide."

**NOTE :**

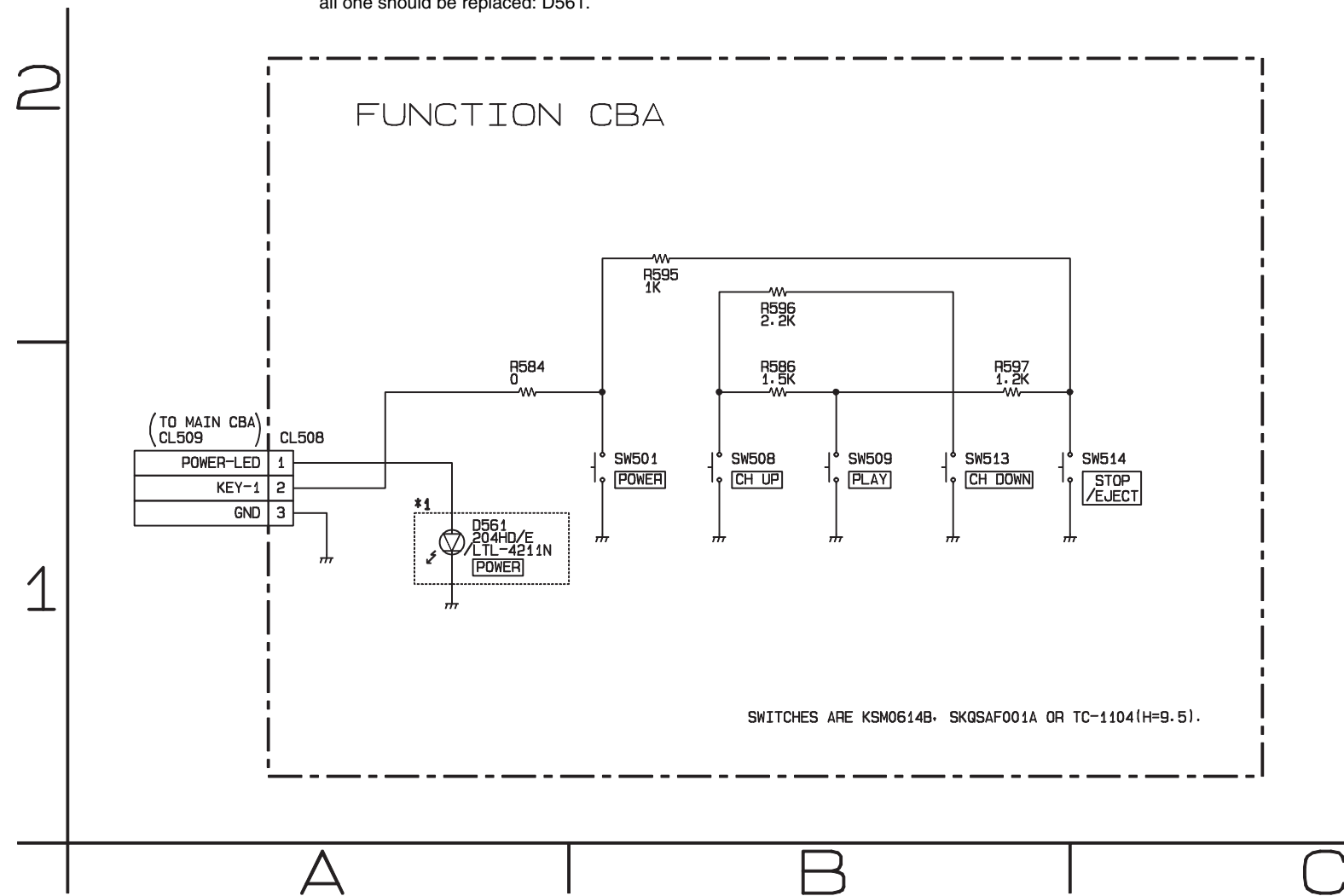
The voltage for parts in hot circuit is measured using hot GND as a common terminal.



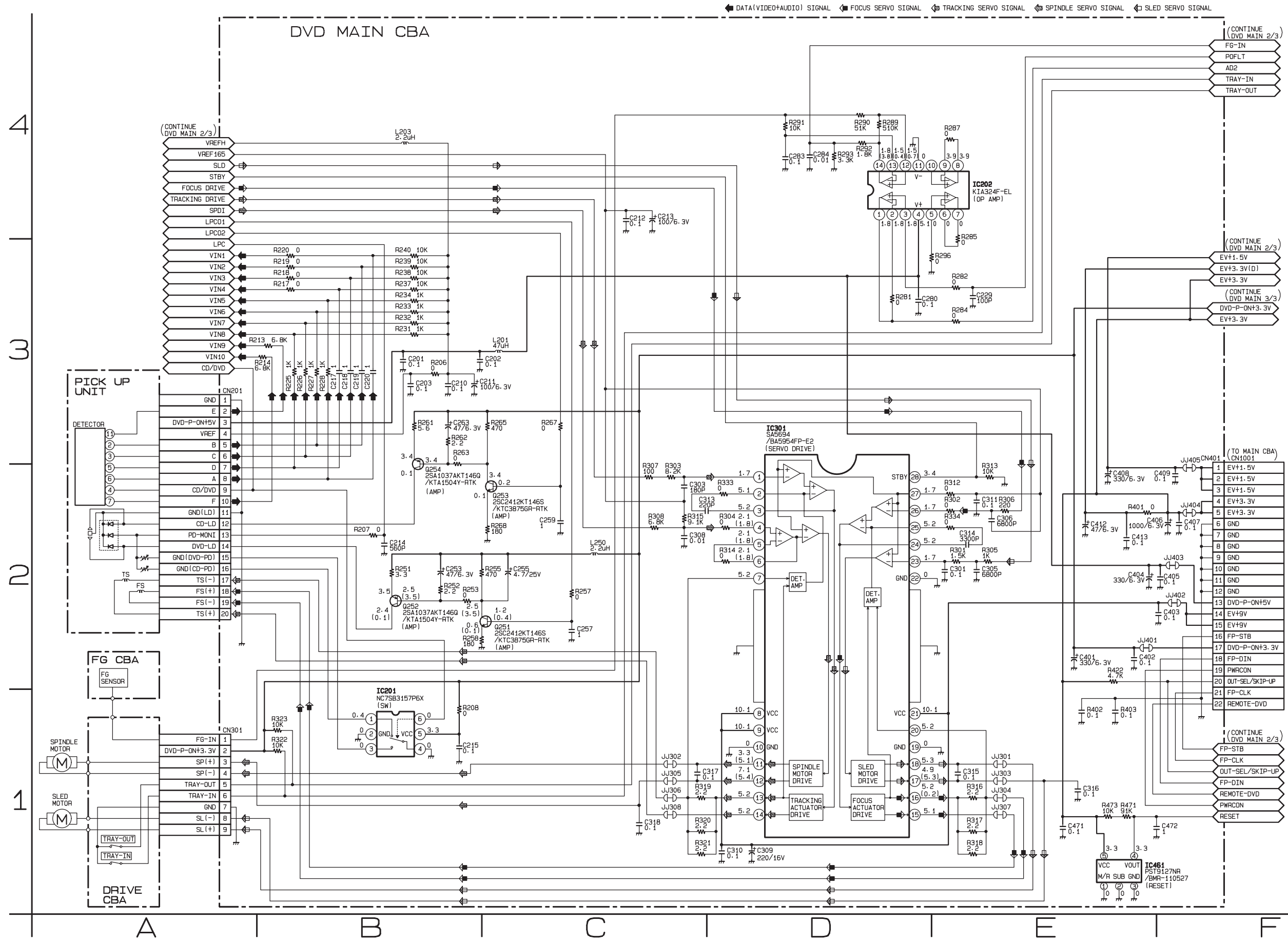
UNLESS OTHERWISE SPECIFIED:  
 DIODES ARE 1N4148M OR 1SS133(T-77).

### 3-10 Function Schematic Diagram

**\* 1 Note:**  
 When it is necessary to replace one or more of the following Diodes,  
 all one should be replaced: D561.

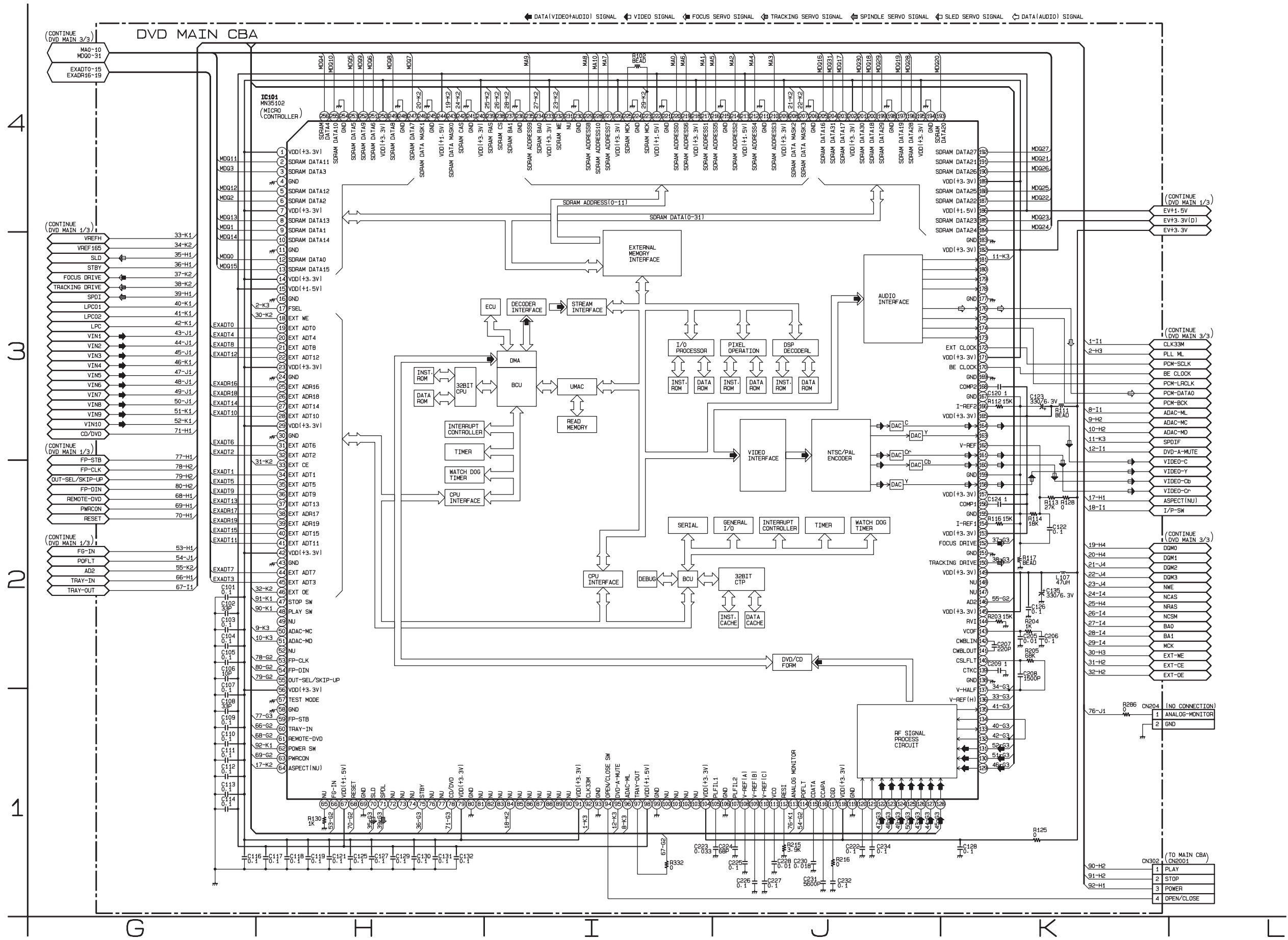


# 3-11 DVD Main 1/3 Schematic Diagram





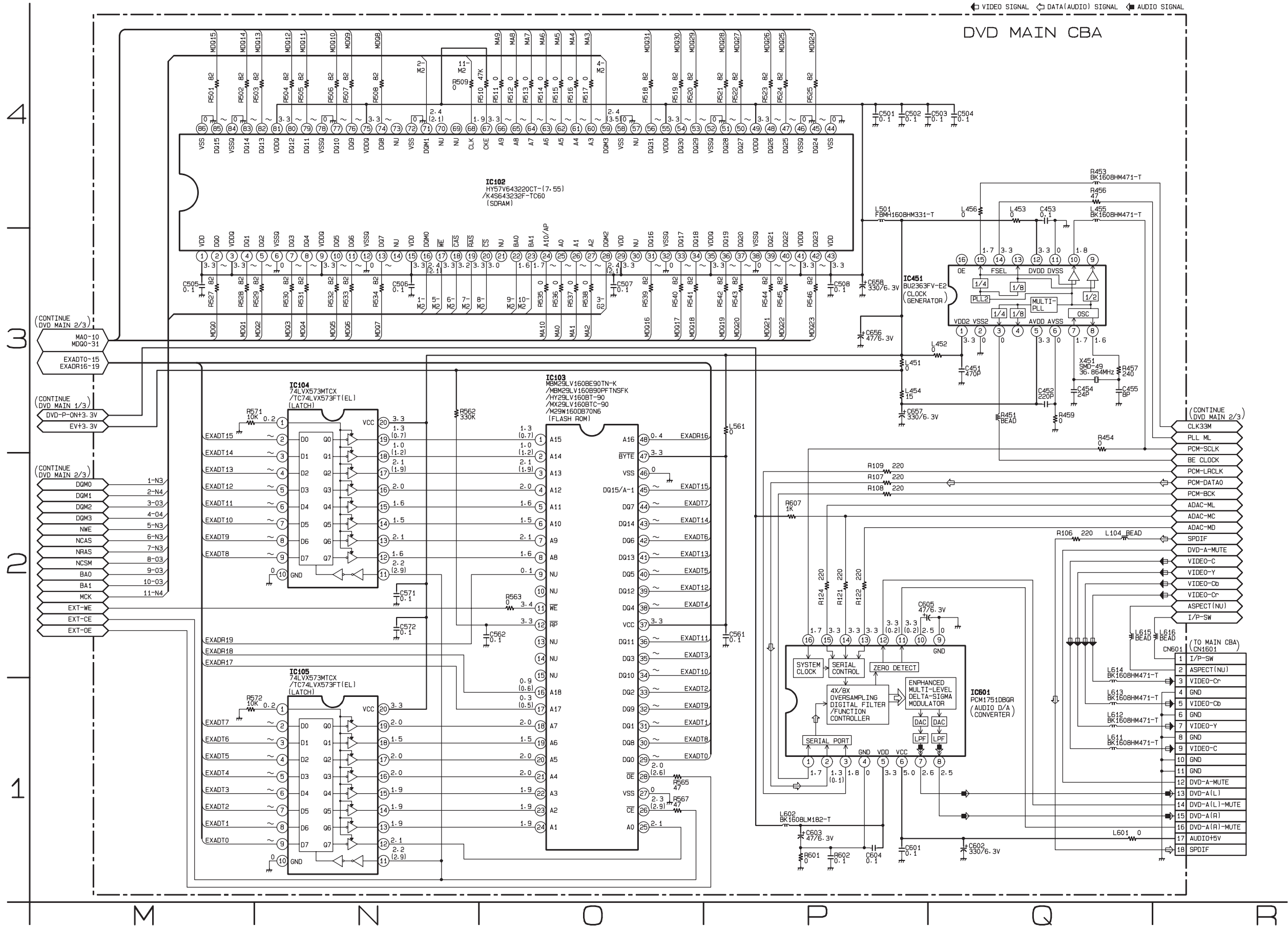
# 3-12 DVD Main 2/3 Schematic Diagram



## IC101 VOLTAGE CHART

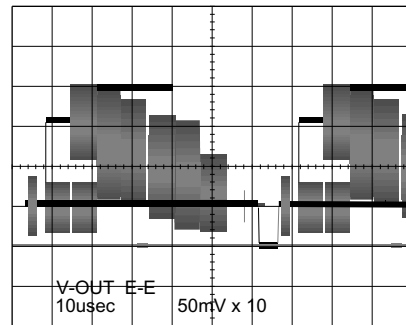
PIN.NO	PLAY	STOP	PIN.NO	PLAY	STOP	PIN.NO	PLAY	STOP	PIN.NO	PLAY	STOP	PIN.NO	PLAY	STOP	PIN.NO	PLAY	STOP	PIN.NO	PLAY	STOP	PIN.NO	PLAY	STOP
1	3.3	3.3	33	2.2	2.9	65	0.1	0.1	97	3.4	3.4	129	2.0	2.0	161	0.5	0.5	193	~	~	225	1.9	1.9
2	~	~	34	~	~	66	1.2	2.5	98	1.6	1.6	130	2.2	2.2	162	1.4	1.4	194	0	0	226	3.3	3.3
3	~	~	35	~	~	67	1.6	1.6	99	0	0	131	2.3	2.3	163	----	----	195	3.3	3.3	227	~	~
4	0	0	36	~	~	68	3.4	3.4	100	----	----	132	0.4	0.1	164	0.9	0.9	196	~	~	228	~	~
5	~	~	37	~	~	69	0	0	101	----	----	133	1.2	0.4	165	3.3	3.3	197	~	~	229	~	~
6	~	~	38	0.3	0.5	70	1.7	1.7	102	----	----	134	0.4	0.1	166	1.5	1.5	198	0	0	230	0	0
7	3.3	3.3	39	0.1	0.1	71	2.4	1.7	103	----	----	135	0.2	0.2	167	0	0	199	~	~	231	----	----
8	~	~	40	~	~	72	----	----	104	3.3	3.3	136	2.3	2.3	168	2.1	2.1	200	~	~	232	3.3	3.3
9	~	~	41	~	~	73	----	----	105	0.9	0.9	137	1.7	1.7	169	0	0	201	~	~	233	3.3	3.3
10	~	~	42	3.3	3.3	74	----	----	106	0	0	138	0	0	170	0.8	0.8	202	3.3	3.3	234	1.6	1.6
11	0	0	43	0	0	75	3.4	3.4	107	0.8	0.8	139	1.7	1.7	171	3.3	3.3	203	~	~	235	~	~
12	~	~	44	~	~	76	----	----	108	1.6	1.6	140	1.7	1.7	172	1.6	1.6	204	~	~	236	0	0
13	~	~	45	~	~	77	----	----	109	2.1	2.1	141	1.7	1.7	173	----	----	205	~	~	237	1.7	1.7
14	3.3	3.3	46	2.0	2.6	78	0.1	0.1	110	2.6	2.6	142	1.7	1.7	174	1.8	1.8	206	0	0	238	3.0	3.0
15	1.5	1.5	47	3.3	3.4	79	3.3	3.3	111	2.0	2.0	143	0.5	0.5	175	1.7	1.7	207	2.4	3.5	239	3.3	3.3
16	0	0	48	3.2	3.4	80	0	0	112	0.7	0.9	144	1.6	1.6	176	1.4	0.1	208	2.4	2.1	240	3.3	3.3
17	3.4	3.4	49	----	----	81	----	----	113	2.1	2.1	145	3.3	3.3	177	0	0	209	3.3	3.3	241	0	0
18	3.4	3.4	50	3.4	3.4	82	----	----	114	1.8	1.8	146	1.8	1.8	178	----	----	210	~	~	242	3.2	3.2
19	~	~	51	3.4	3.4	83	----	----	115	1.4	1.4	147	----	----	179	----	----	211	0	0	243	2.4	2.1
20	~	~	52	----	----	84	----	----	116	0.3	0.3	148	----	----	180	----	----	212	~	~	244	1.5	1.5
21	~	~	53	3.4	3.4	85	----	----	117	1.6	1.6	149	3.3	3.3	181	1.7	1.7	213	1.5	1.5	245	0	0
22	~	~	54	3.4	3.4	86	----	----	118	3.3	3.3	150	1.7	1.7	182	3.3	3.3	214	~	~	246	2.4	2.1
23	3.3	3.3	55	3.3	3.3	87	----	----	119	0	0	151	0	0	183	0	0	215	0	0	247	~	~
24	0	0	56	3.3	3.3	88	----	----	120	1.9	1.9	152	1.7	1.7	184	~	~	216	~	~	248	0	0
25	0.4	0.4	57	0	0	89	----	----	121	1.9	1.9	153	3.3	3.3	185	~	~	217	~	~	249	~	~
26	0.9	0.6	58	0	0	90	----	----	122	2.4	2.4	154	1.4	1.4	186	1.5	1.5	218	3.3	3.3	250	3.3	3.3
27	~	~	59	3.3	3.3	91	3.3	3.3	123	2.4	2.4	155	0	0	187	~	~	219	~	~	251	~	~
28	~	~	60	3.4	3.4	92	1.7	1.5	124	2.4	2.4	156	2.2	2.2	188	~	~	220	~	~	252	~	~
29	3.3	3.3	61	3.1	3.1	93	0	0	125	2.4	2.4	157	3.3	3.3	189	3.3	3.3	221	0	0	253	~	~
30	0	0	62	3.2	3.4	94	----	----	126	2.0	2.0	158	0.7	0.7	190	~	~	222	1.5	1.5	254	0	0
31	~	~	63	3.4	3.4	95	3.4	0.1	127	2.0	2.0	159	0	0	191	~	~	223	1.9	1.9	255	~	~
32	~	~	64	----	----	96	3.4	3.4	128	2.0	2.0	160	0.5	0.5	192	~	~	224	0	0	256	~	~

# 3-13 DVD Main 3/3 Schematic Diagram



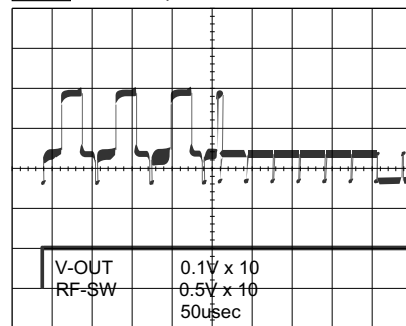
# 4 WAVEFORMS

**WF1** (TP751 of Main CBA)



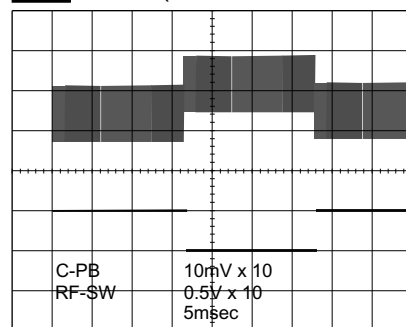
**WF1** UPPER (TP751 of Main CBA)

**WF2** LOWER (TP302 of Main CBA)

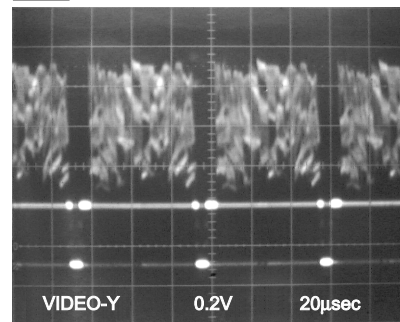


**WF3** UPPER (TP301 of Main CBA)

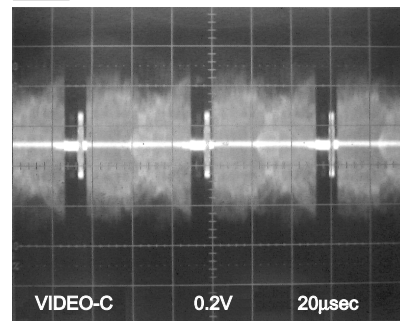
**WF2** LOWER (TP302 of Main CBA)



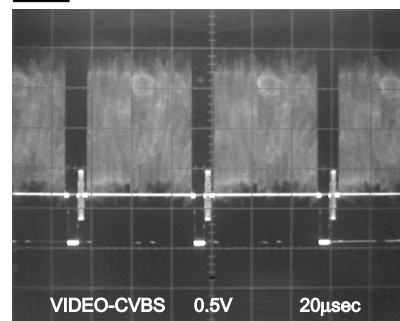
**WF4** Pin 7 of CN1601



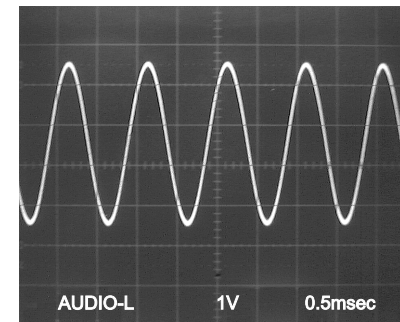
**WF5** Pin 9 of CN1601



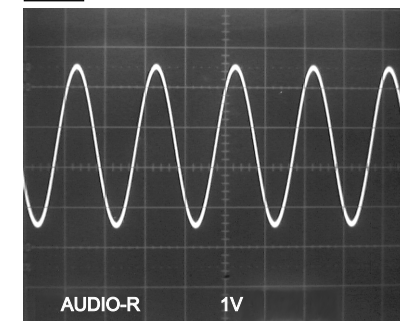
**WF6** Pin 21 of IC1402



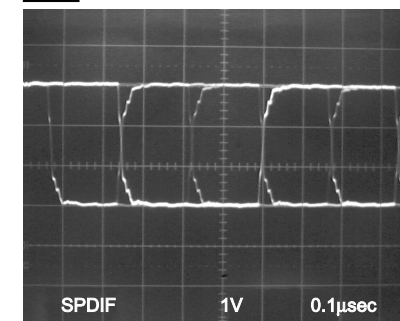
**WF7** Pin 13 of CN1601



**WF8** Pin 15 of CN1601



**WF9** Pin 18 of CN1601



**NOTE:**

Input

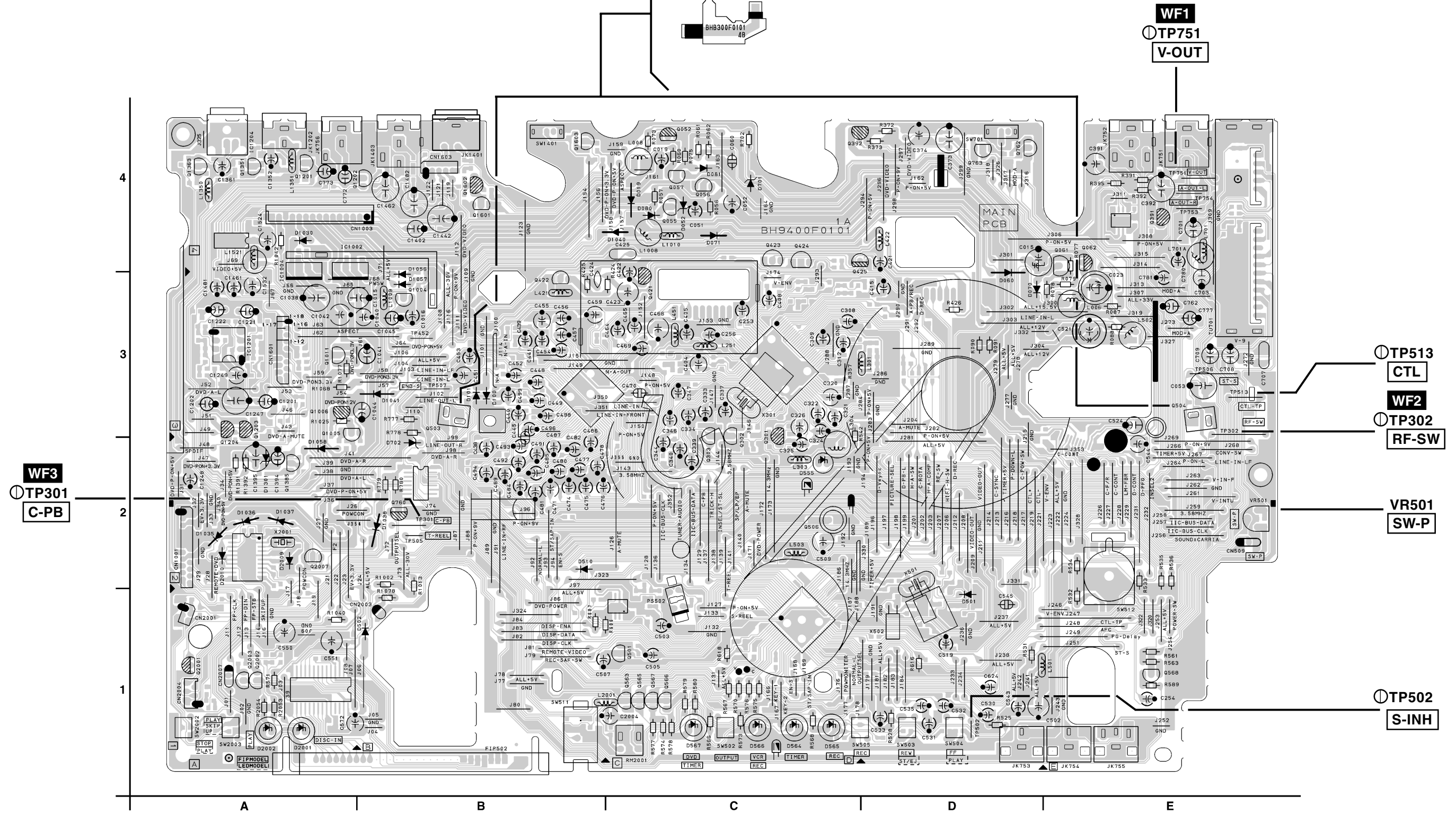
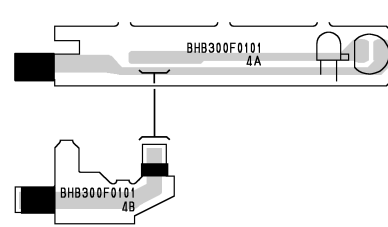
CD: 1kHz PLAY  
(WF7~WF9)

DVD: POWER ON (STOP) MODE  
(WF4~WF6)

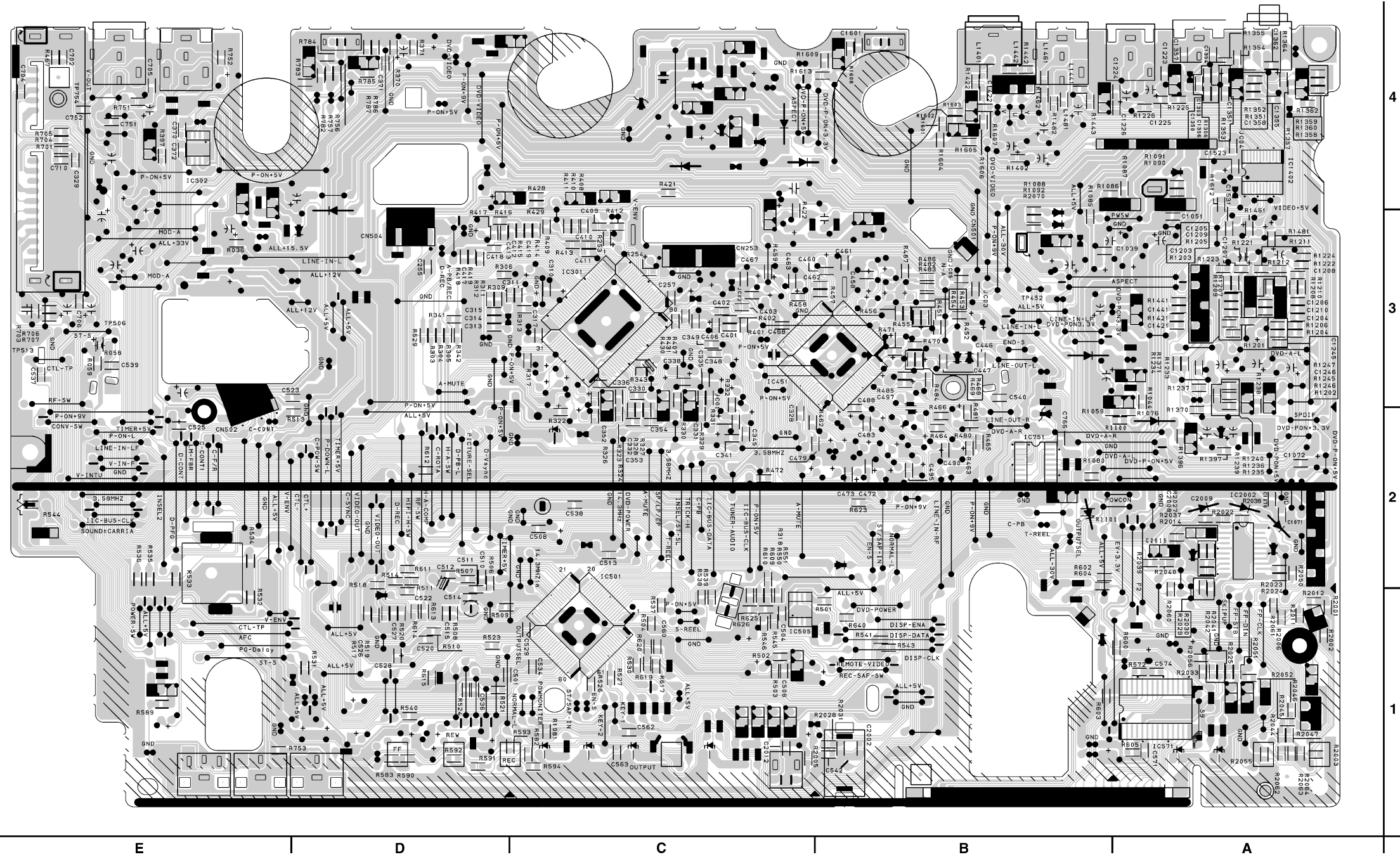
# 5 CIRCUIT BOARD DIAGRAMS

## 5-1 Main CBA Top View & Sensor CBA Top View

Sensor CBA Top View

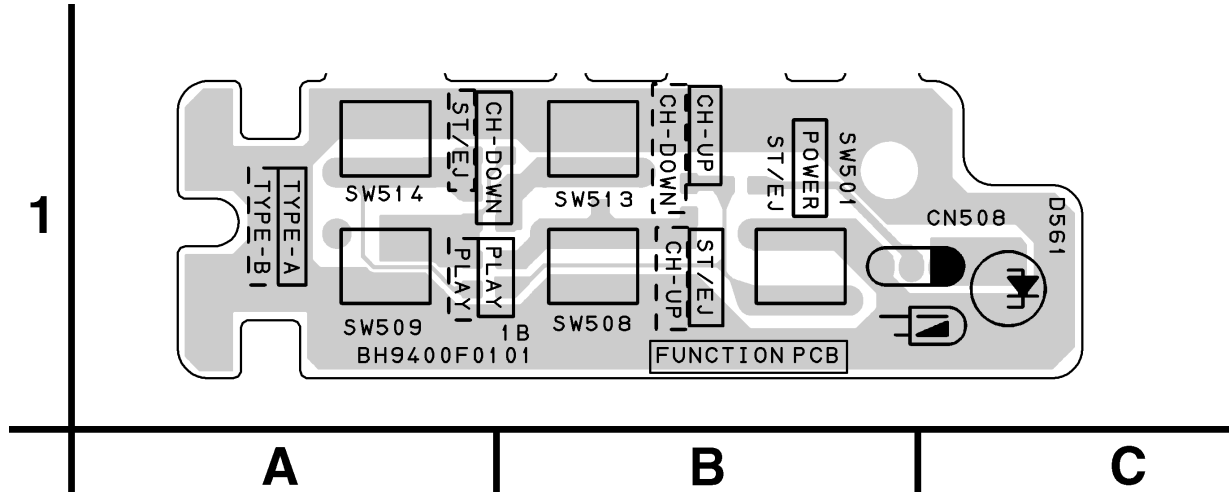


# 5-2 Main CBA Bottom View

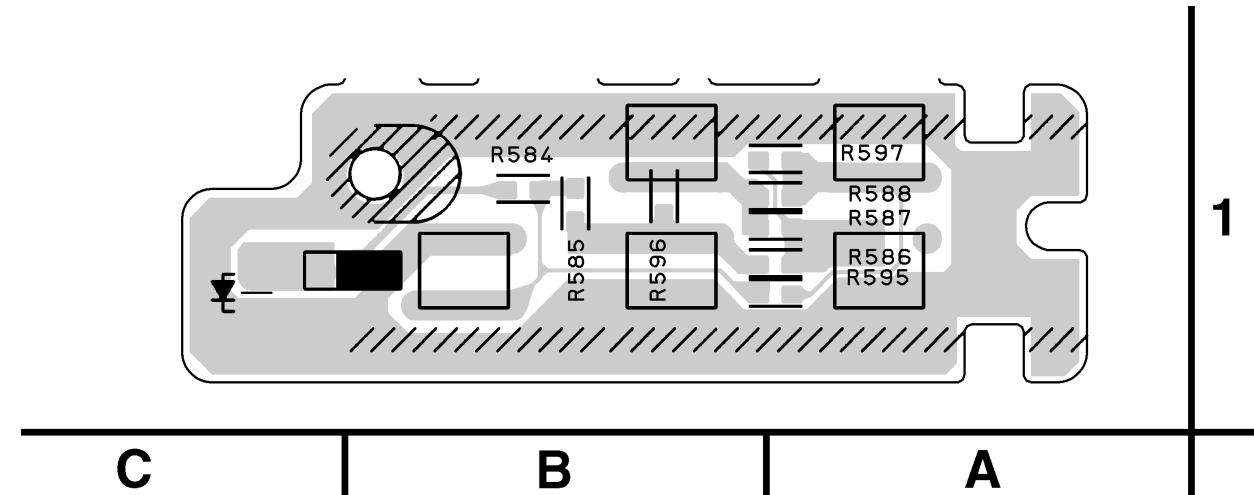


5-3 Function CBA Top/Bottom View & DVD OPEN/CLOSE CBA Top/Bottom View

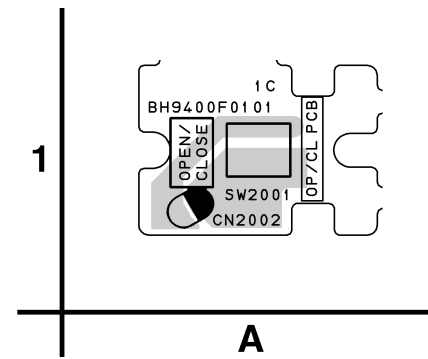
Function CBA Top View



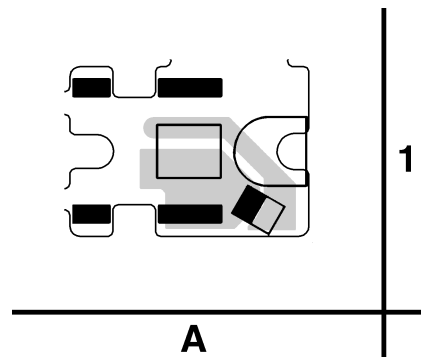
Function CBA Bottom View



DVD OPEN/CLOSE CBA Top View

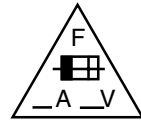


DVD OPEN /CLOSE CBA Bottom View



# 5-4 Power Supply CBA Top/Bottom View

## Power Supply CBA Top View



**CAUTION**

FOR CONTINUED PROTECTION AGAINST FIRE HAZARD, REPLACE ONLY WITH THE SAME TYPE FUSE.  
 ATTENTION : POUR UNE PROTECTION CONTINUE LES RISQUES D'INCELE N'UTILISER QUE DES FUSIBLE DE MÊME TYPE.  
**RISK OF FIRE-REPLACE FUSE AS MARKED.**



"This symbol means fast operating fuse."  
 "Ce symbole représente un fusible à fusion rapide."

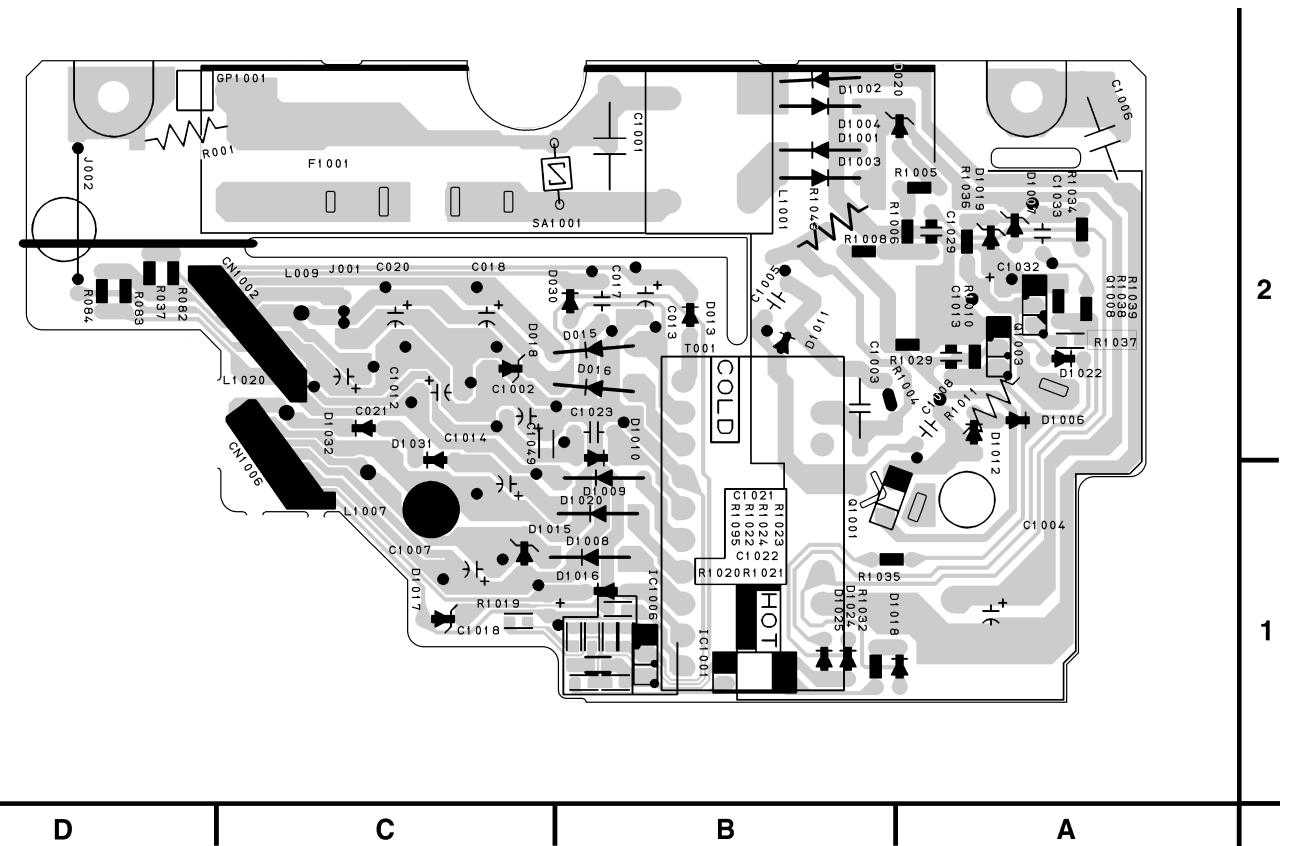
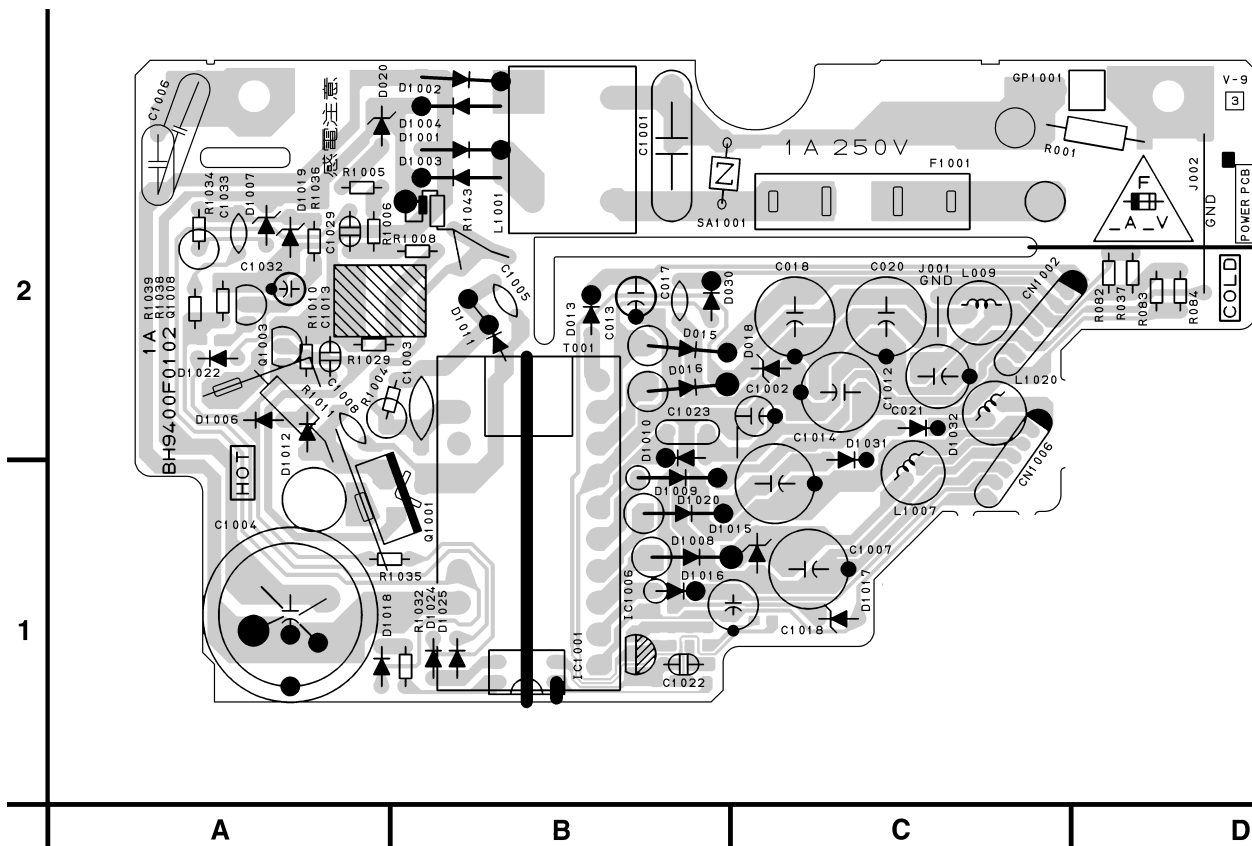
**CAUTION !**

Fixed voltage ( or Auto voltage selectable ) power supply circuit is used in this unit. If Main Fuse (F1001) is blown, check to see that all components in the power supply circuit are not defective before you connect the AC plug to the AC power supply. Otherwise it may cause some components in the power supply circuit to fail.

**BECAUSE A HOT CHASSIS GROUND IS PRESENT IN THE POWER SUPPLY CIRCUIT , AN ISOLATION TRANSFORMER MUST BE USED. ALSO , IN ORDER TO HAVE THE ABILITY TO INCREASE THE INPUT SLOWLY , WHEN TROUBLESHOOTING THIS TYPE POWER SUPPLY CIRCUIT , A VARIABLE ISOLATION TRANSFORMER IS REQUIRED.**

**NOTE :**

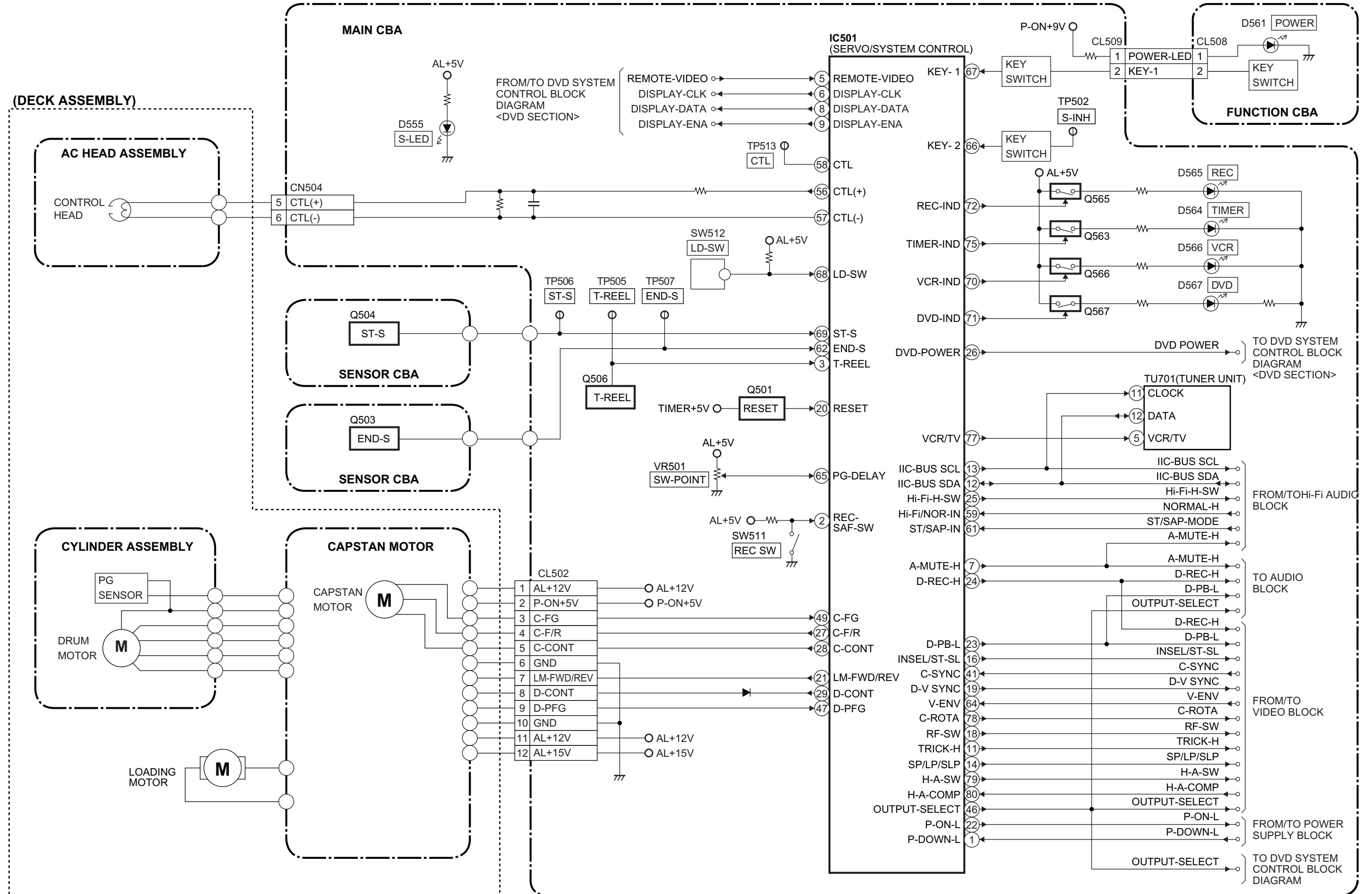
The voltage for parts in hot circuit is measured using hot GND as a common terminal.





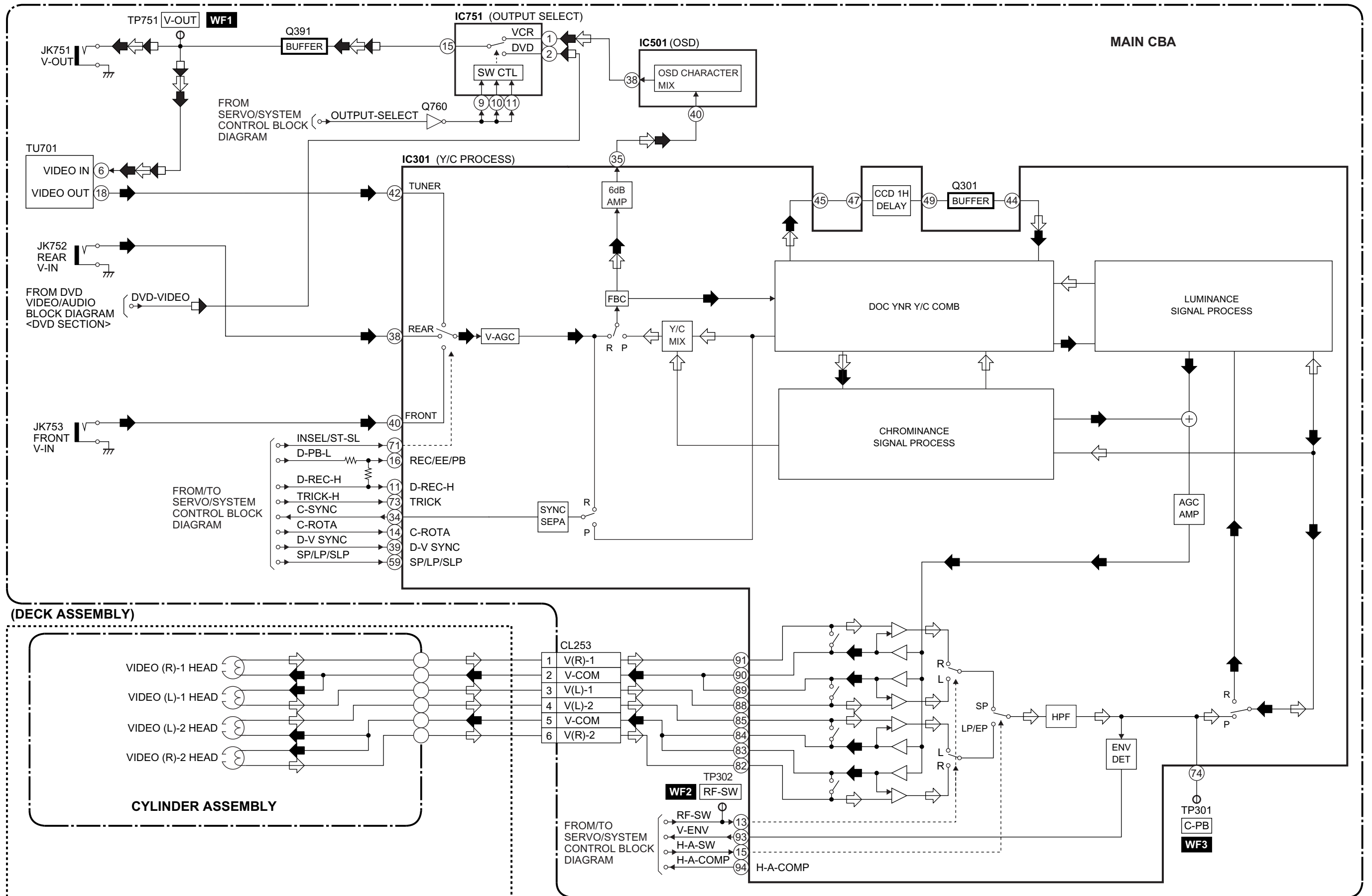
# 6 BLOCK DIAGRAMS

## 6-1 Servo/System Control Block Diagram



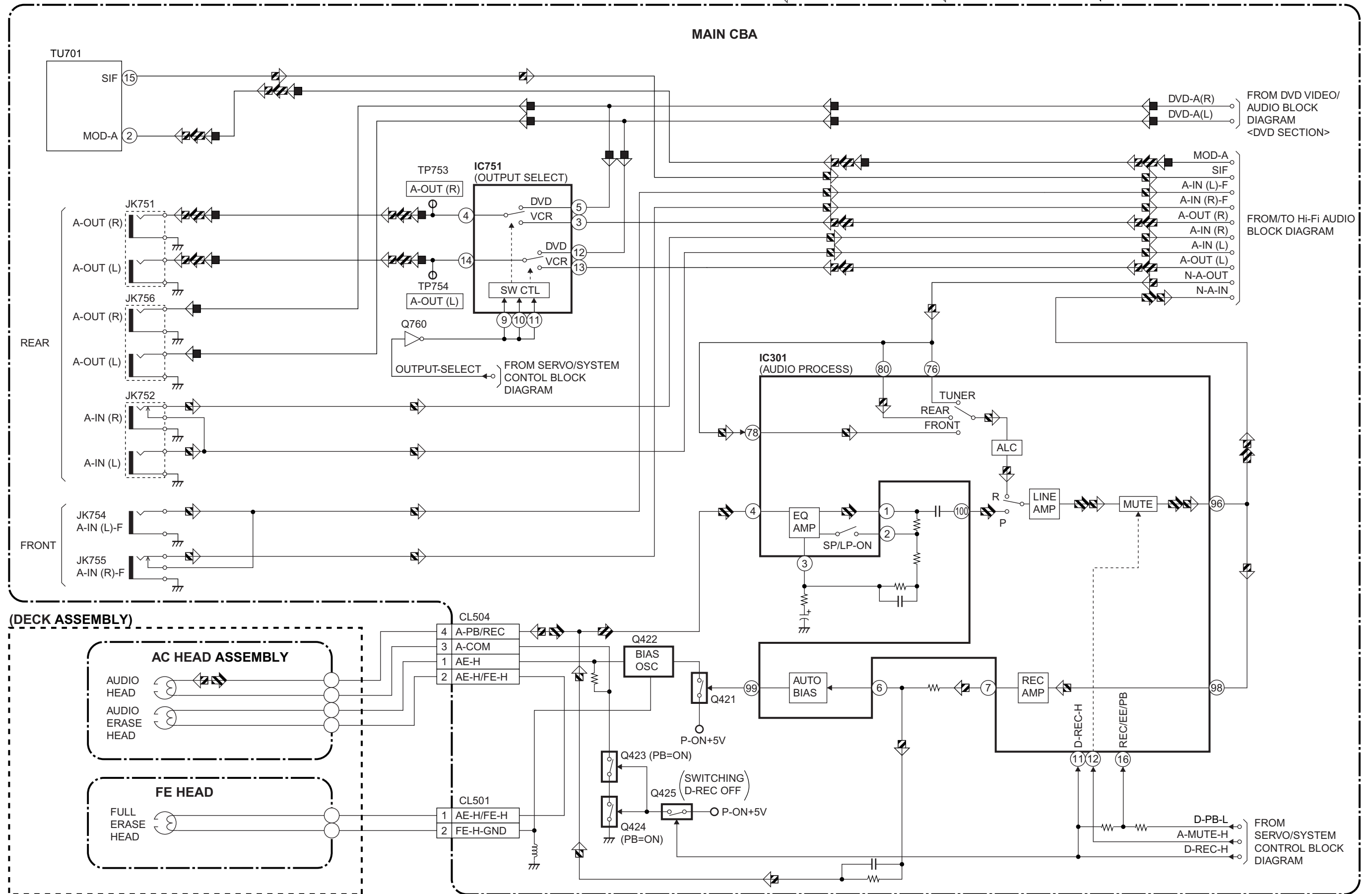
# 6-2 Video Block Diagram

← REC VIDEO SIGNAL   ← PB VIDEO SIGNAL   ← DVD VIDEO SIGNAL   MODE: SP/REC

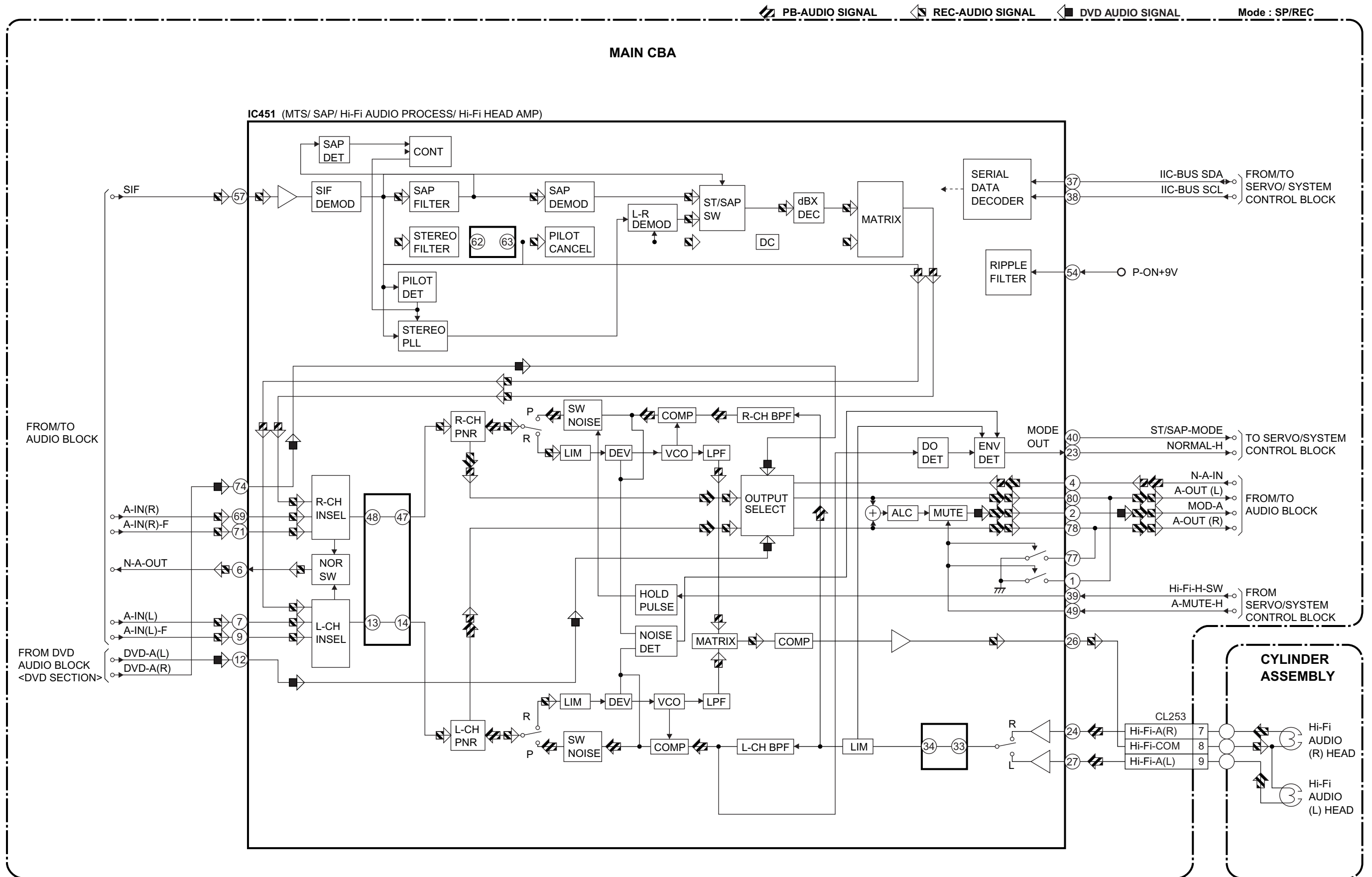


# 6-3 Audio Block Diagram

PB-AUDIO SIGNAL  
 REC-AUDIO SIGNAL  
 DVD AUDIO SIGNAL  
 Mode : SP/REC

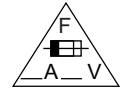


# 6-4 Hi-Fi Audio Block Diagram



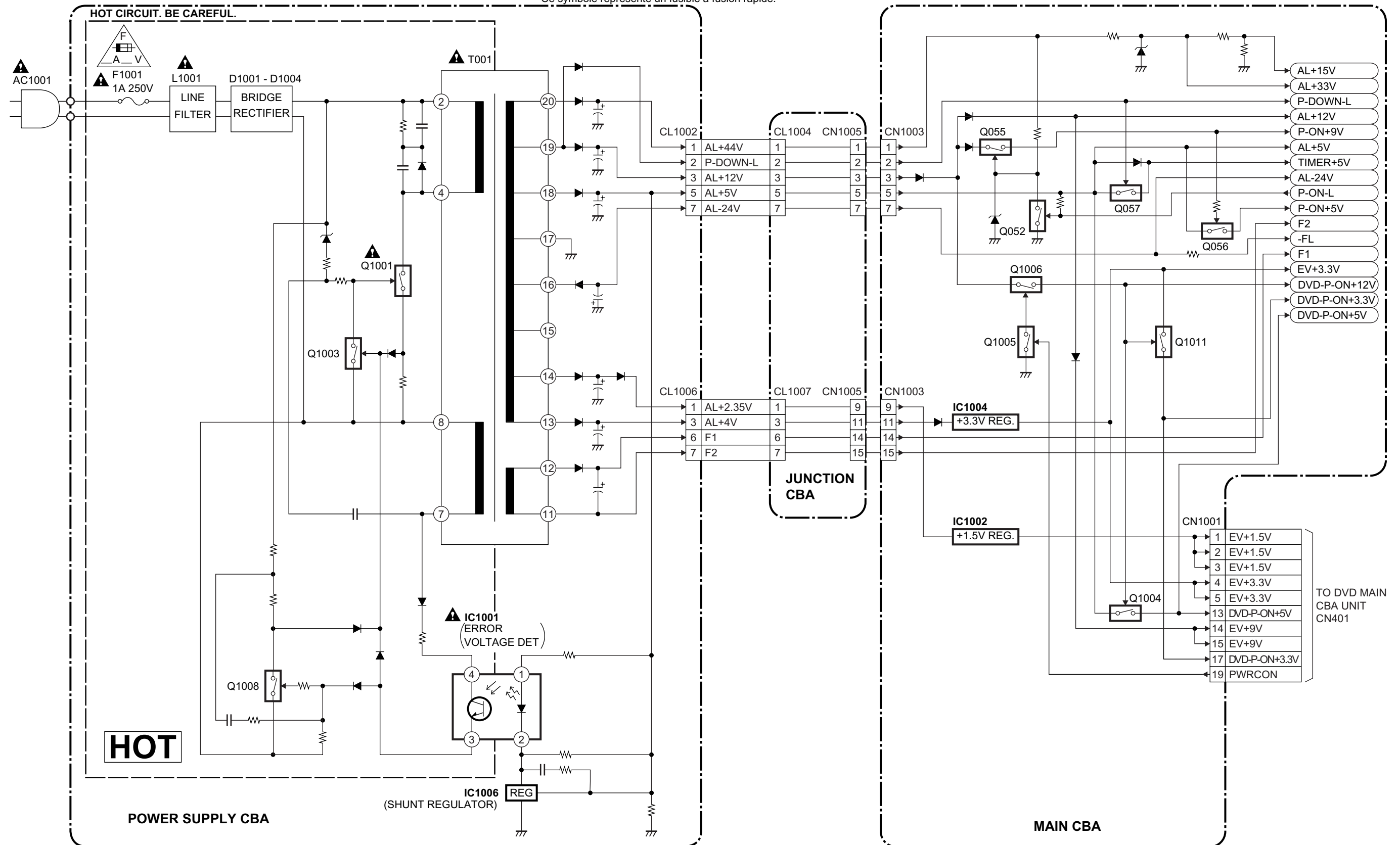
# 6-5 Power Supply Block Diagram

**NOTE :**  
The voltage for parts in hot circuit is measured using hot GND as a common terminal.

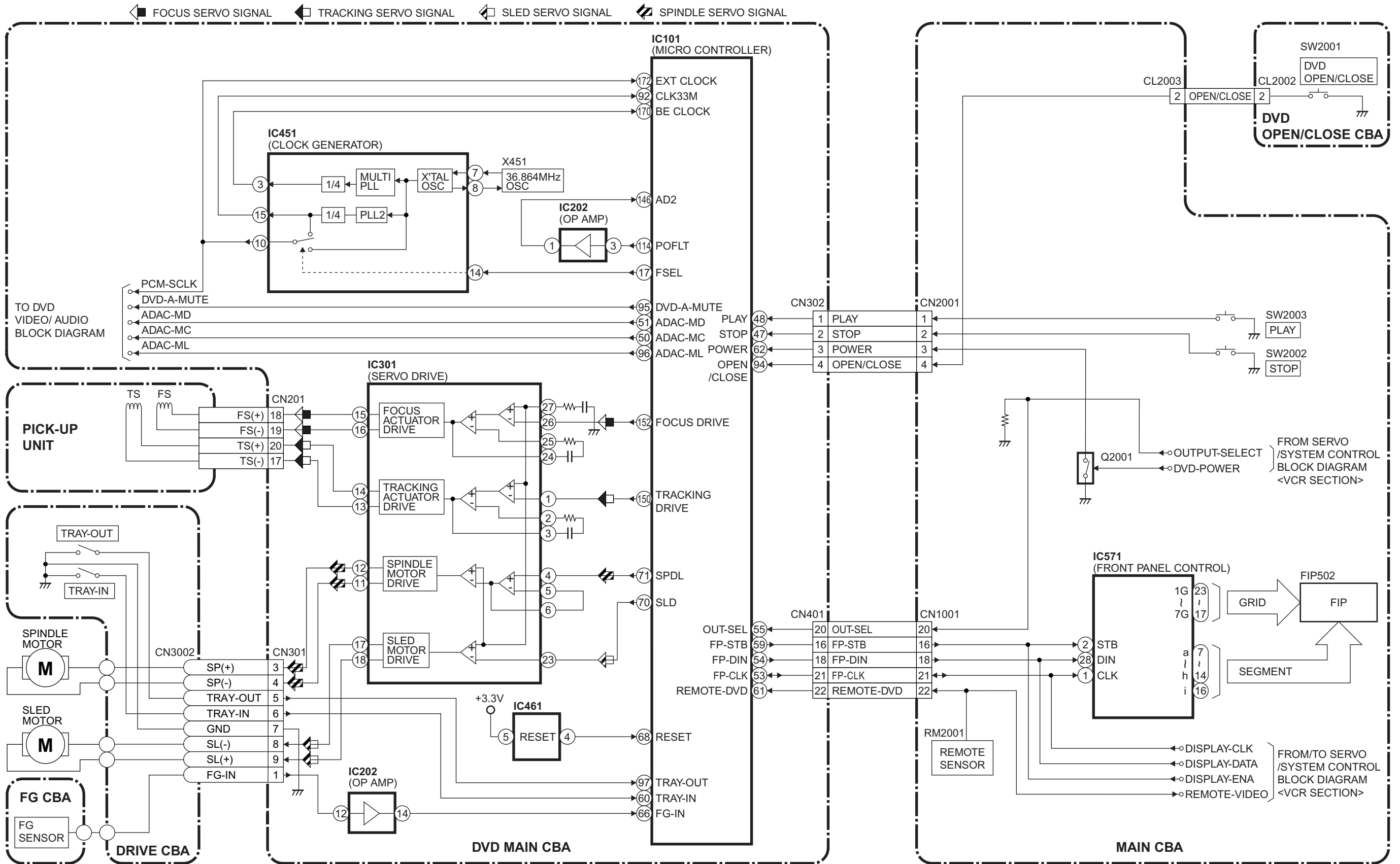


**CAUTION**  
FOR CONTINUED PROTECTION AGAINST FIRE HAZARD,  
REPLACE ONLY WITH THE SAME TYPE FUSE.  
**ATTENTION :** POUR UNE PROTECTION CONTINUE LES RISQUES  
D'INCELE N'UTILISER QUE DES FUSIBLE DE MEMO TYPE.  
**RISK OF FIRE -REPLACE FUSE AS MARKED.**  
"This symbol means fast operating fuse."  
"Ce symbole représente un fusible à fusion rapide."

**CAUTION !**  
Fixed voltage ( or Auto voltage selectable ) power supply circuit is used in this unit.  
If Main Fuse (F001) is blown, check to see that all components in the power supply  
circuit are not defective before you connect the AC plug to the AC power supply.  
Otherwise it may cause some components in the power supply circuit to fail.

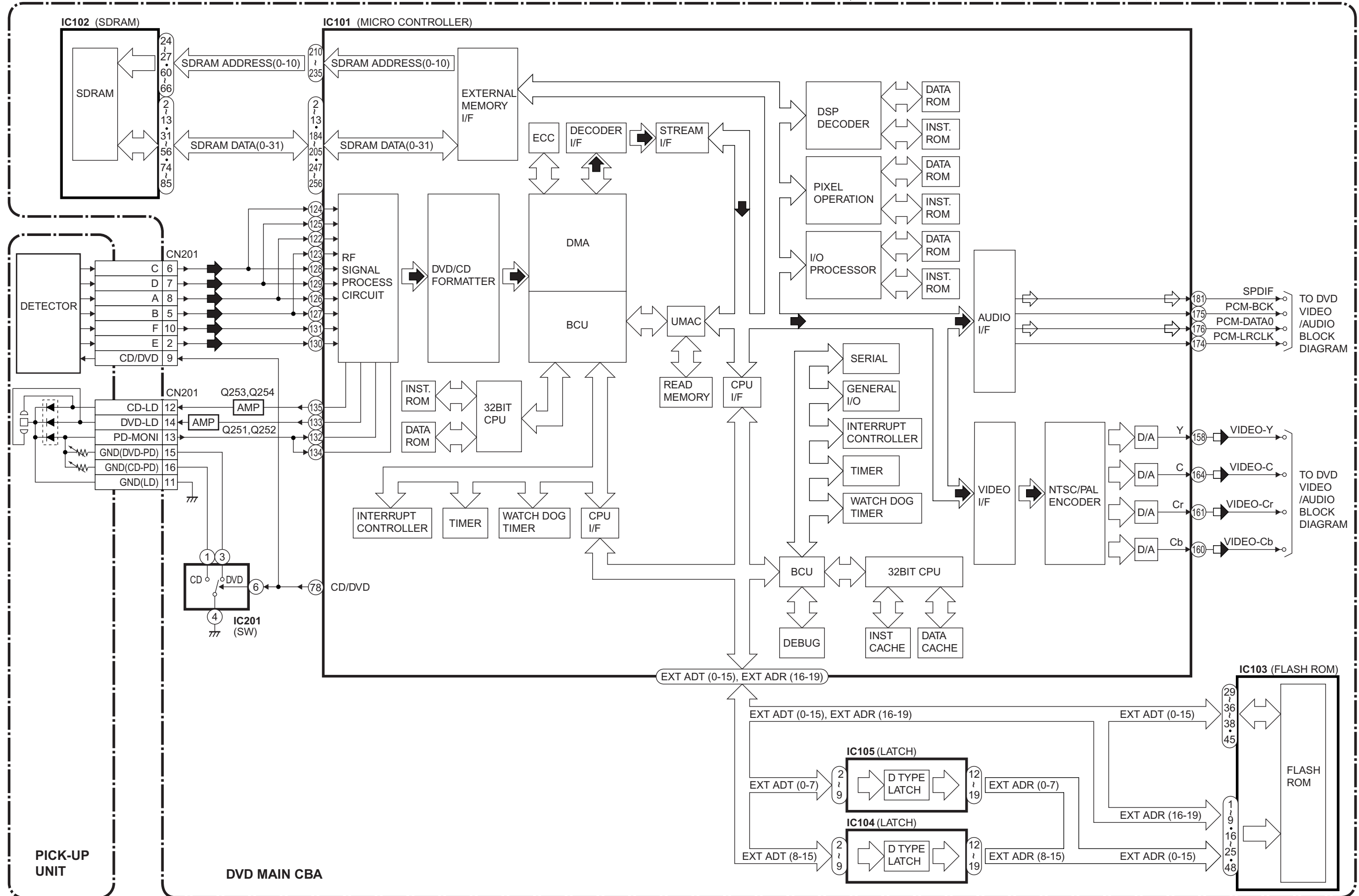


# 6-6 DVD System Control/Servo Block Diagram



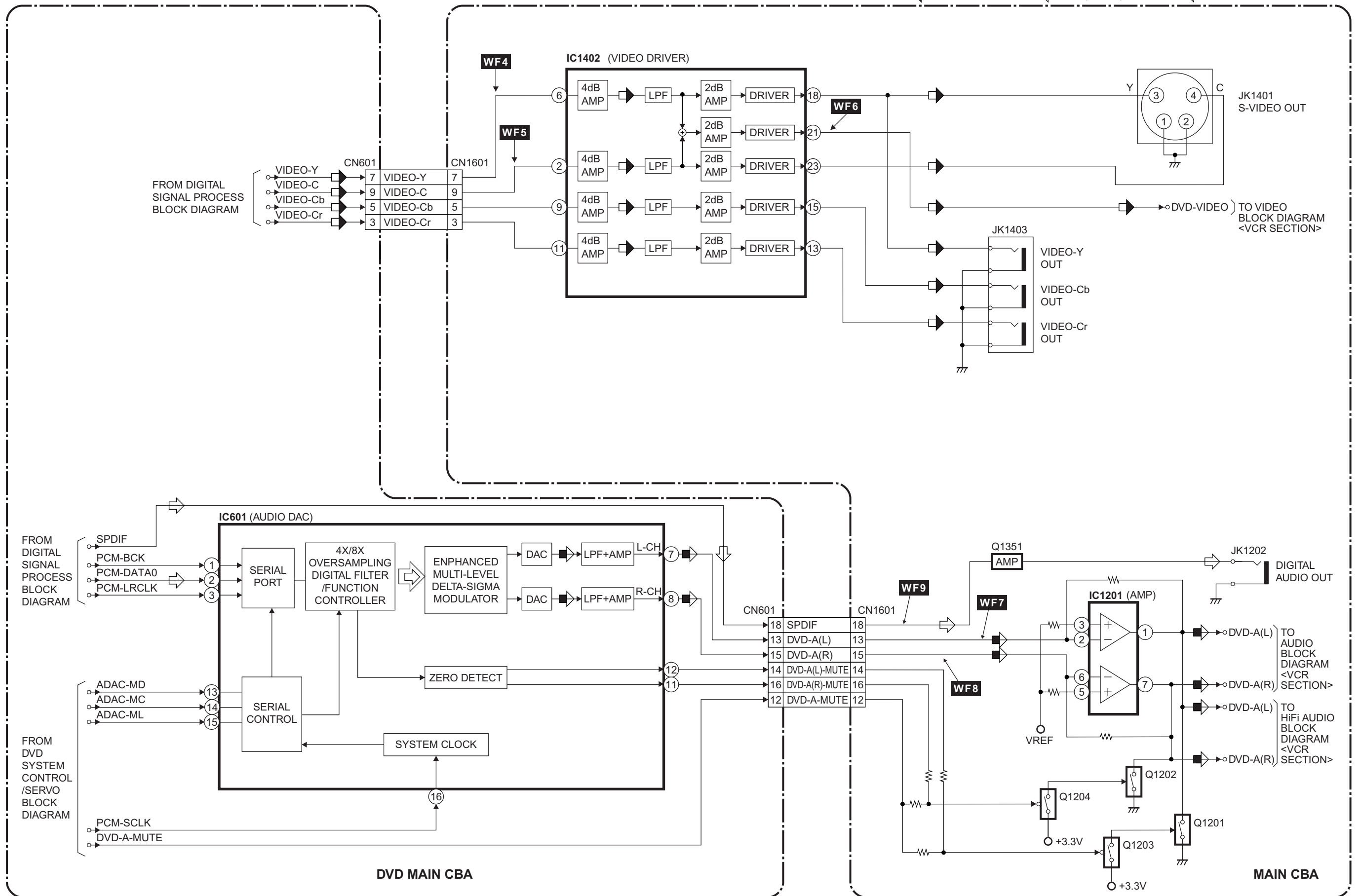
# 6-7 Digital Signal Process Block Diagram

▶ DATA(VIDEO/AUDIO) SIGNAL  
 ◀ DVD VIDEO SIGNAL  
 ◀ DATA(AUDIO) SIGNAL



# 6-8 DVD Video / Audio Block Diagram

◻ DVD VIDEO SIGNAL ◻ DATA(AUDIO) SIGNAL ◼ DVD AUDIO SIGNAL





# 7 SYSTEM CONTROL TIMING CHARTS

[ VCR Section ]

Mode SW : LD-SW

LD-SW Position detection A/D Input voltage Limit (Calculated voltage)	Symbol
3.76V~4.50V (4.12V)	EJ
4.51V~5.00V (5.00V)	CL
0.00V~0.25V (0.00V)	SB
1.06V~1.50V (1.21V)	TL
0.66V~1.05V (0.91V)	FB
1.99V~2.60V (2.17V)	SF
1.51V~1.98V (1.80V)	SM
3.20V~3.75V (3.40V)	AU
0.26V~0.65V (0.44V)	AL
4.51V~5.00V (5.00V)	SS
2.61V~3.19V (2.97V)	RS

Note:

Note:  
 EJ → RS: Loading FWD (LM-FWD/REV "H")  
 RS → EJ: Loading REV (LM-FWD/REV "L")  
 Stop (A) = Loading  
 Stop (B) = Unloading

Note:

Symbol	Loading Status
EJ	Eject
CL	Eject ~ REW Reel
SB	REW Reel ~ Stop(B)
TL	Stop(B) ~ Brake Cancel
FB	Brake Cancel ~ FF / REW
SF	FF / REW ~ Stop(M), (FF / REW)
SM	Stop(M), (FF / REW) ~ Stop(A)
AU	Stop(A) ~ Play / REC
AL	Play / REC ~ Still / Slow
SS	Still / Slow ~ RS (REW Search)
RS	RS (REW Search)

## Still/Slow Control Frame Advance Timing Chart

1) SP Mode

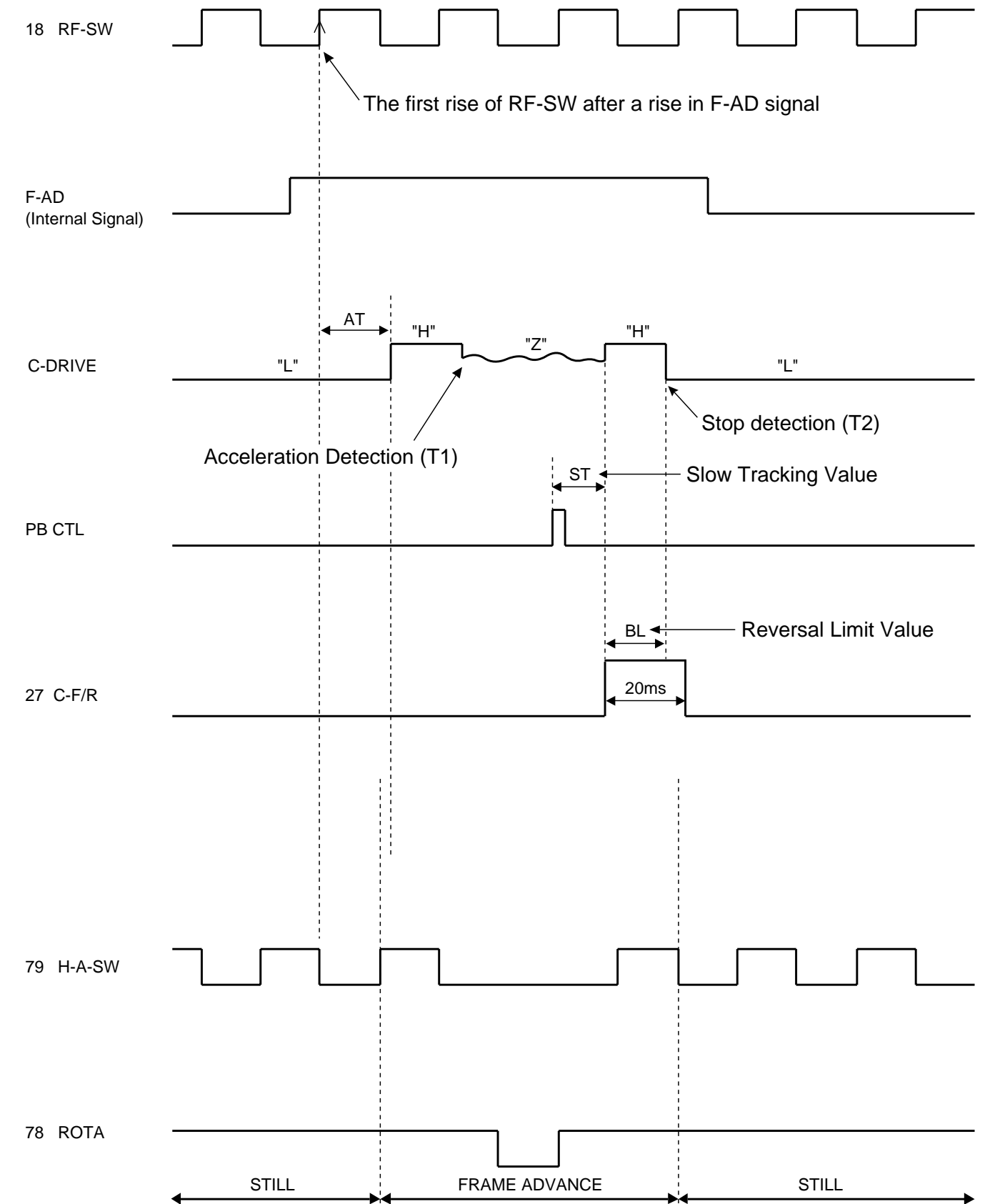


Fig. 1

## 2) LP/SLP Mode

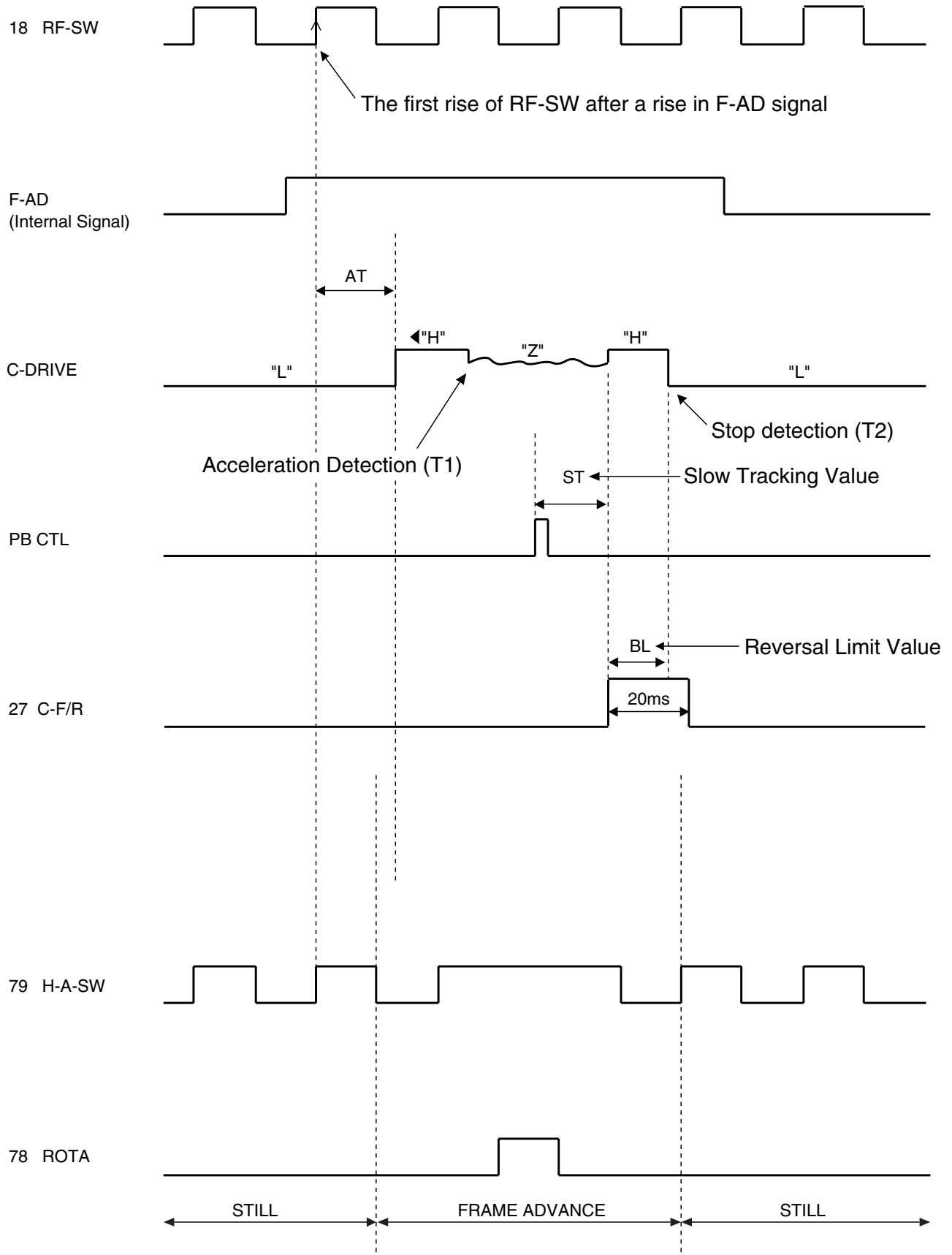


Fig. 2

1. EJECT (POWER OFF) -> CASSETTE IN (POWER ON) -> STOP(B) -> STOP(A) -> PLAY -> RS -> FS -> PLAY -> STILL -> PLAY -> STOP(A)

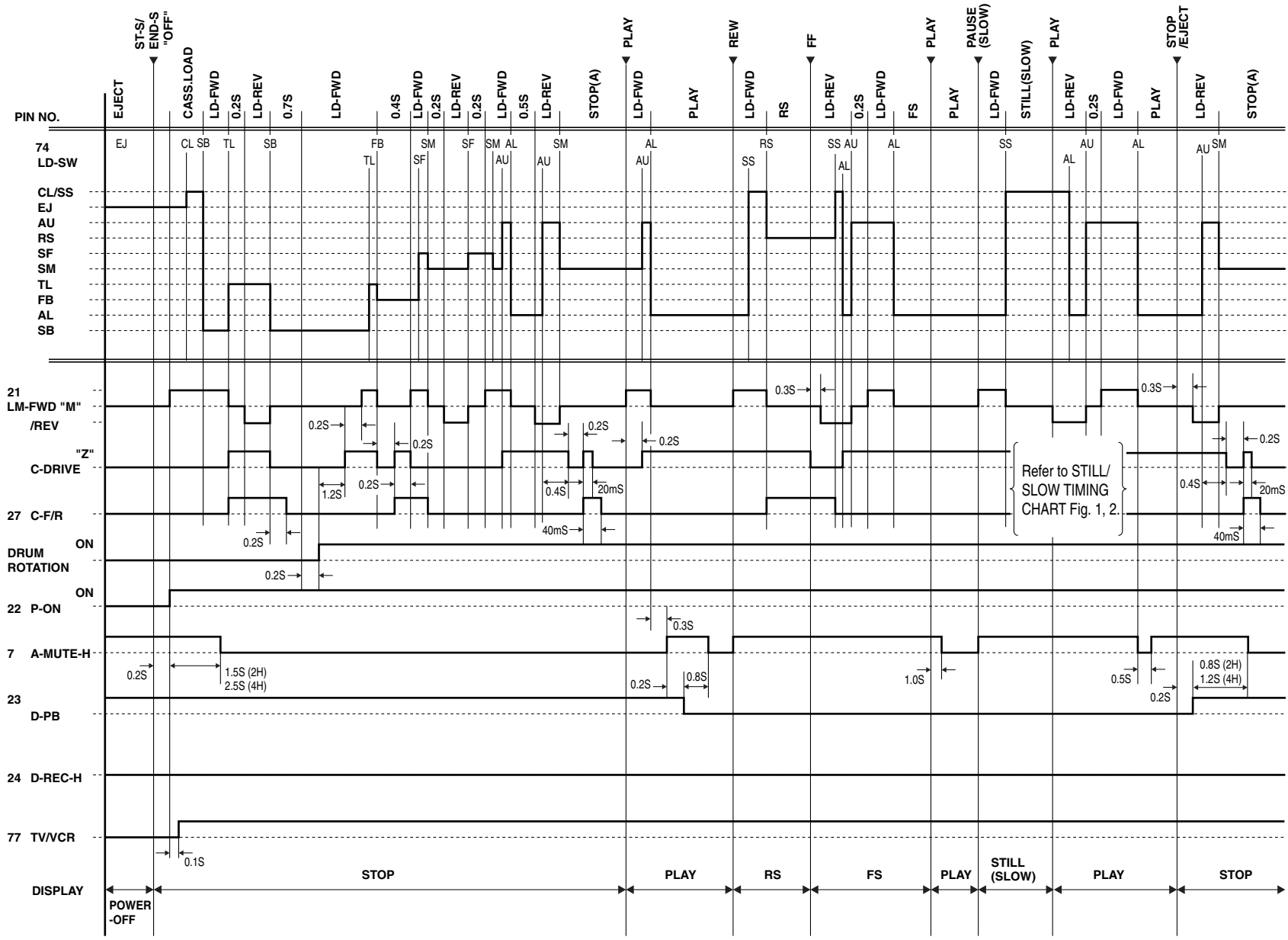


Fig. 3

2. STOP(A) -> FF -> STOP(A) -> REW -> STOP(A) -> REC -> PAUSE -> PAUSE or REC -> STOP(A) -> EJECT

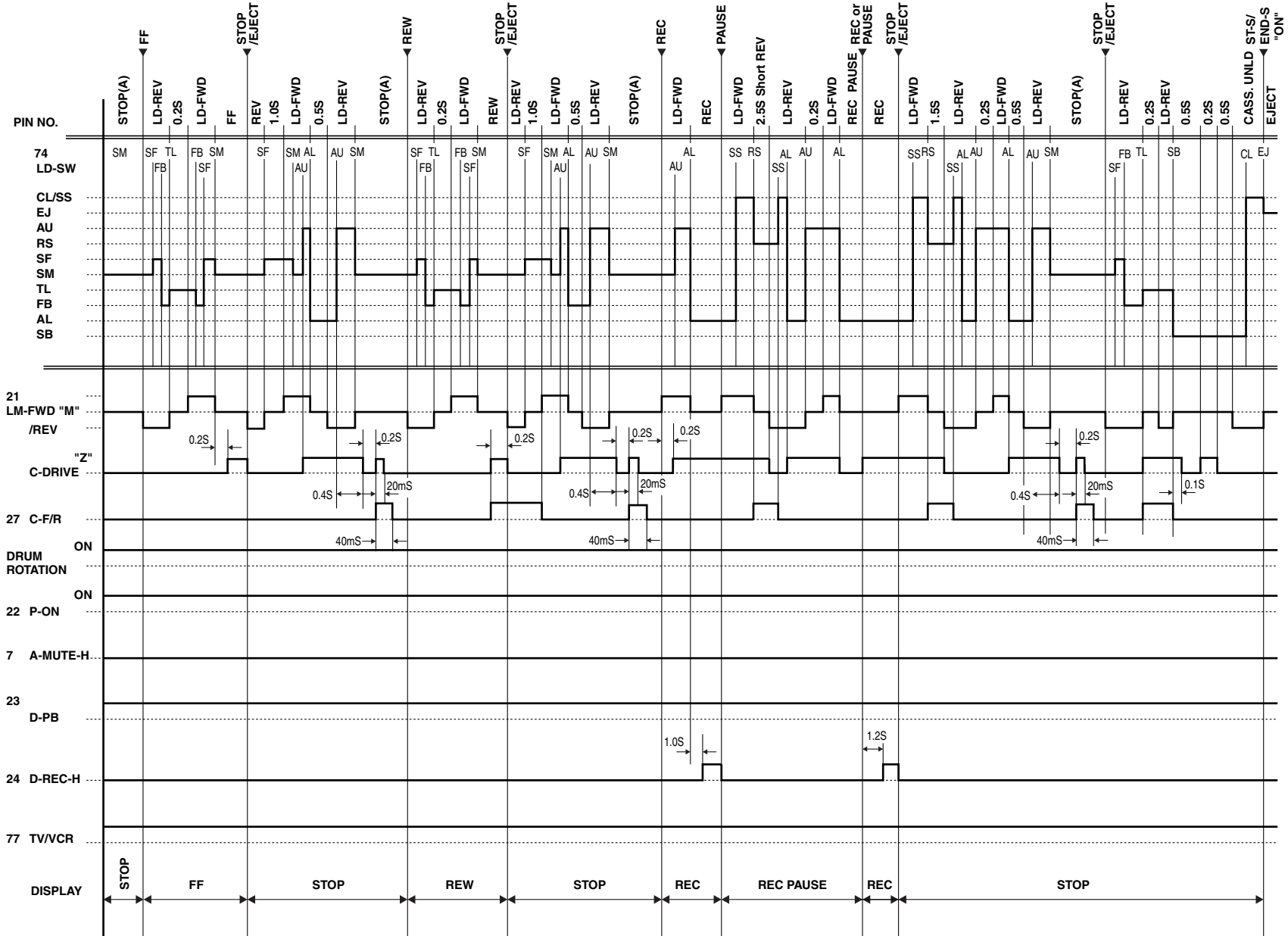
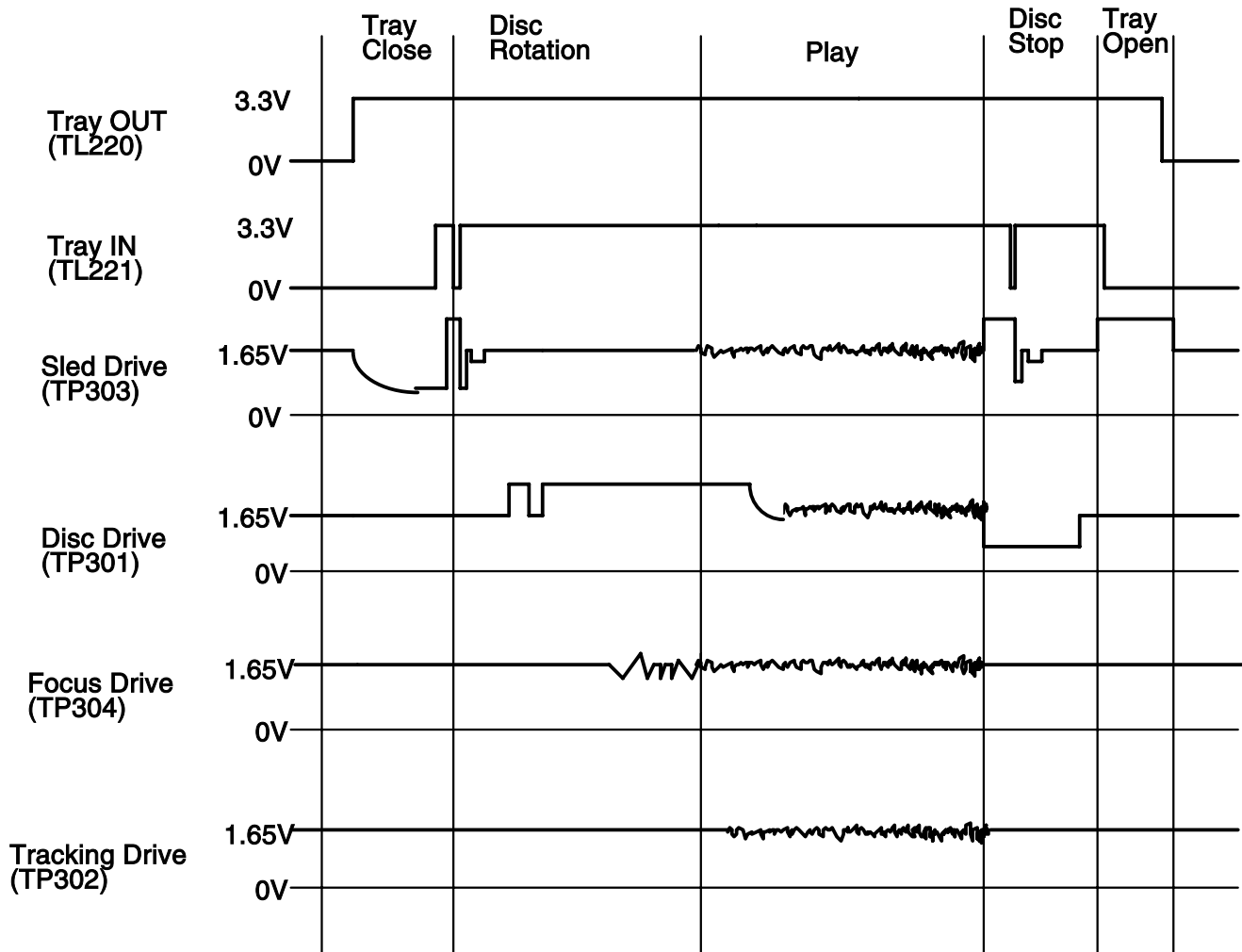


Fig. 4

# [ DVD Section ]

Tray Close ~ Play / Play ~ Tray Open



# 8 IC PIN FUNCTION DESCRIPTIONS

## [ VCR Section ]

### IC501( SERVO / SYSTEM CONTROL IC )

“H” ≥ 4.5V, “L” ≤ 1.0V

Pin No.	IN/OUT	Signal Name	Function	Active Level
1	IN	P-DOWN -L	Power Voltage Down Detector Signal	L
2	IN	REC-SAF-SW	Recording Safety SW Detect (With Record tab = "L"/ With out Record tab = "H")	H/L
3	IN	T-REEL	Take Up Reel Rotation Signal	PULSE
4	-	N.U.	Not Used	-
5	IN	REMOTE-VIDEO	Remote Control Sensor	L
6	OUT	DISPLAY-CLK	7seg. Driver IC Clock Control Output Signal	H/L
7	OUT	A-MUTE-H	Audio Mute Control Signal (Mute = "H")	H
8	OUT	DISPLAY-DATA	7seg. Driver IC Data Control Output Signal	H/L
9	OUT	DISPLAY-ENA	7seg. Driver IC Enable Control Output Signal	L
10	-	N.U.	Not Used	-
11	OUT	TRICK-H	Special Playback= "H"	H/Z/L
12	IN/OUT	IIC-BUS-SDA	IIC BUS Control Data	H/L
13	OUT	IIC-BUS-SCL	IIC BUS Control Clock	H/L
14	OUT	SP/LP/SLP	Top Speed Select Signal (SP="L"/ LP="Z"/SLP="H")	H/Z/L
15	-	N.U.	Not Used	-
16	OUT	INSEL/ST-SL	Input Selector Control Signal (EE/Rec)/Still/Slow (Playback)	H/Hi-z /L
17	OUT	PICTURE-SEL	Picture Control Signal	-

Pin No.	IN/OUT	Signal Name	Function	Active Level
18	OUT	RF-SW	Video Head Switching Pulse	H/L
19	OUT	D-V SYNC	Dummy V-sync Output	H/Hi-z
20	IN	RESET	System Reset Signal (Reset="L")	L
21	OUT	LM-FWD/REV	Loading Motor FWD/ REV Output	H/Z/L
22	OUT	P-ON-L	Power On Signal to Low	L
23	OUT	D-PB-L	Playback Instruction Signal	L
24	OUT	D-REC-H	Delayed Record Signal	H
25	OUT	HiFi-H-SW	HiFi Audio Head Switching Pulse	H/L
26	OUT	DVD-POWER	DVD Power Control Signal	H
27	OUT	C-F/R	Capstan Motor FWD/REV Control Signal (FWD="L"/ REV="H")	H/L
28	OUT	C-CONT	Capstan Motor Control Signal	PWM
29	OUT	D-CONT	Drum Motor Control Signal	PWM
30	-	N.U.	Not Used	-
31	-	VDD	VDD	-
32	OUT	OSCO	Main Clock Output 14.31818MHz	-
33	IN	OSCI	Main Clock Input 14.31818MHz	-
34	-	VSS	VSS	-
35	IN	XI	Sub Clock Input 32.768 MHz	-
36	OUT	XO	Sub Clock Output 32.768 MHz	-
37	IN	SXI	Operation Mode Selecting Input Signal	-
38	OUT	VIDEO-OUT	Composite Video Signal Output	-
39	-	Vss2	Vss2	-
40	IN	VIDEO-IN	Composite Video Signal Input	-

Pin No.	IN/OUT	Signal Name	Function	Active Level
41	IN	C-SYNC	Composite Synchronized Pulse	PULSE
42	-	VDD2	VDD2	-
43	IN	AFCC	Low Path Filter Input Signal For AFC	-
44	OUT	AFCLPF	Low Path Filter Output Signal For AFC	-
45	-	N.U.	Not Used	-
46	OUT	OUTPUT-SELECT	Output Select	H/L
47	IN	D-PFG	Drum PG/FG Input Signal	PULSE
48	-	N.U.	Not Used	-
49	IN	C-FG	Capstan Motor Rotation Detection Pulse	PULSE
50	-	AFG	GND	-
51	OUT	VRO	Servo Standard Voltage Output	-
52	IN	VRI	Servo Standard Voltage Input	-
53	-	AVss	AVSS	-
54	IN	CTLA	CTL Amp. AC GND	-
55	-	AVDD	AVDD	-
56	IN/OUT	CTL (+)	Playback/Record Control Signal (+)	-
57	IN/OUT	CTL (-)	Playback/Record Control Signal (-)	-
58	OUT	CTL	Amp. Output Control Signal for Test Point	-
59	IN	HiFi/NOR-IN	Audio Mode Input HiFi="L"/ Normal="H"	A/D
60	IN	POW-MONITOR	DVD Power Monitor Signal (P-off="L", P-on="H")	H/L
61	IN	ST/SAP-IN	Tuner Stereo/Sap Detector Signal Input	A/D
62	IN	END-S	Tape End Position Detect Signal	A/D
63	IN	AFC	Automatic Frequency Control Signal	A/D

Pin No.	IN/OUT	Signal Name	Function	Active Level
64	IN	V-ENV	Video Envelope Comparator Signal	A/D
65	IN	PG-DELAY	Video Head Switching Pulse Signal Adjusted Voltage	A/D
66	IN	KEY-2	A/D Key Data Signal 2	A/D
67	IN	KEY-1	A/D Key Data Signal 1	A/D
68	IN	LD-SW	Deck Mode Position Detector Signal	A/D
69	IN	ST-S	Tape Start Position Detector Signal	A/D
70	OUT	VCR-IND	VCR Mode LED Signal Output	H/L
71	OUT	DVD-IND	DVD Mode LED Signal Output	H/L
72	OUT	REC-IND	REC Mode LED Signal Output	H/L
73	-	N.U.	Not Used	-
74	-	N.U.	Not Used	-
75	OUT	TIMER-IND	"TIMER" LED Signal Output	H/L
76	OUT	CONV-SW	RF Conv. Output Channel Switching Signal 3ch="Hi-z", 4ch="L"	Hi-z/L
77	OUT	VCR/TV	RF Conv. ON/OFF Signal (TV="L"/ VCR="H")	H/L
78	OUT	C-ROTA	Color Phase Rotary Changeover Signal	H/L
79	OUT	H-A-SW	Video Head Amp Switching Pulse	H/L
80	IN	H-A-COMP	Head Amp Comparator Signal	H/L

**Notes:**

Abbreviation for Active Level:

PWM -----Pulse Wide Modulation

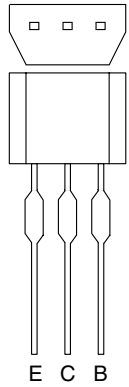
A/D-----Analog - Digital Converter

## IC571 [ PT6313-S-TP ]

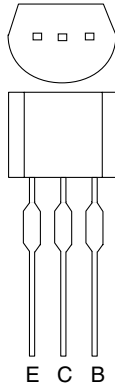
Pin No.	In/Out	Signal Name	Name Function
1	In	CLK	Clock Input
2	In	STB	Serial Interface Strobe
3	-	NU	Not Used
4	-	NU	Not Used
5	-	VSS	GND
6	-	VDD	Power Supply
7	Out	a	Segment Output
8	Out	b	
9	Out	c	
10	Out	d	
11	Out	e	
12	In	f	
13	In	g	
14	Out	h	
15	-	VEE	Pull Down Level
16	Out	i	Segment Output
17	Out	7G	Grid Output
18		6G	
19		5G	
20		4G	
21		3G	
22		2G	
23		1G	
24	-	VDD	Power Supply
25	-	VSS	GND
26	In	OSC	Oscillator Input
27	Out	DOUT	Serial Data Output
28	In	DIN	Serial Data Input



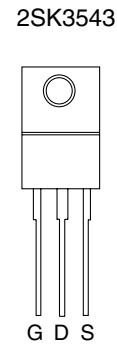
# 9 LEAD IDENTIFICATIONS



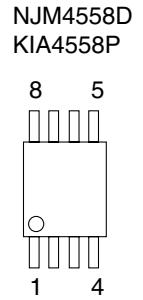
BN1F4M-T  
BA1F4M-T  
KTA1266(GR)  
KTC3193(Y)  
KTC3199(Y,GR,BL)  
2SC2785(J,H,F,K)  
KRC103M  
KRA103M  
2SA1175(J,H,F)  
KTA1267(Y)  
KTA1267(GR)



2SC1815-BL(TPE2)  
2SC1815-Y(TPE2)  
2SC1815-GR(TPE2)  
2SC2120-Y(TPE2)  
KTC3203(Y)  
2SA1015-GR(TPE2)  
KTC3198(Y,GR)  
2SC2001(K)  
2SC2001(L)

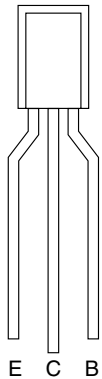


2SK3543



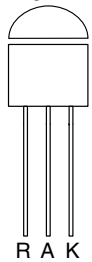
NJM4558D  
KIA4558P

2SC536NF(NG)-NPA-AT



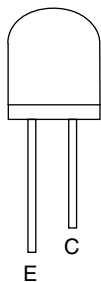
E C B

KIA431-AT  
KIA431A-AT  
TL431A-TA



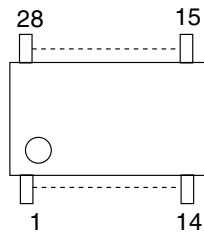
R A K

MID-32A22  
PT204-6B-12



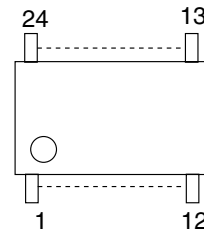
E C

PT6313-S-TP



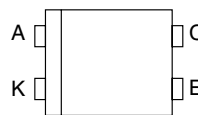
1 14

MM1622XJBE



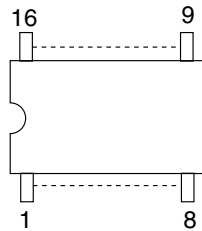
1 12

LTV-817(B,C)-F



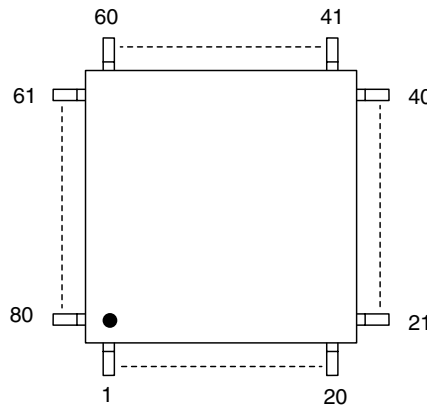
A C  
K E

TC4053BF(N)  
BU4053BCF



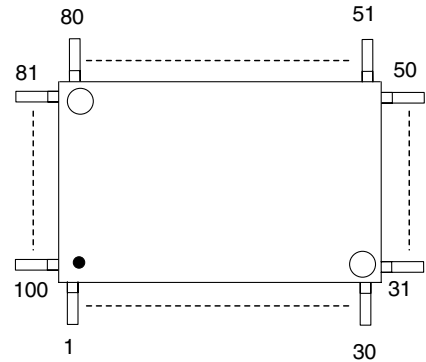
1 8

QSZAB0RMS006  
LA72670M



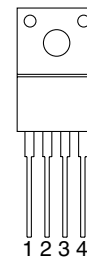
60 41  
61 40  
80 21  
1 20

LA71091M



80 51  
81 50  
100 31  
1 30

PQ070XF01SZ



1 2 3 4

**Note:**

- A: Anode
- K: Cathode
- E: Emitter
- C: Collector
- B: Base
- R: Reference
- S: Source
- G: Gate
- D: Drain

# HITACHI

How to cancel "error code"  
Power -off and power on again

- Error1 Reel rotation is abnormal  
Check the Reel pulse by Oscilloscope  
Test point TP505  
Cause: missing Reel pulse for the following time  
PB/REC : SP 5second,EP 14 second,FF/REW 4 seconds  
Check on D555/Q506 -Pulse entered? If so, check the Capstan Motor.
- Capstan motor abnormal:  
C-FG pulse does not entered for one second, error 1 indicates.
- Check C-FG pulse on IC501 49 pin.  
Check the voltage IC501 1 pin.  
Check the voltage IC501 2 pin.
- Error 2 Tape loading is abnormal  
Mechanism will not be normal position over 7 seconds  
error 2 indicates.
- Error 3 Cassette loading is abnormal  
Over the the following time, error 3 indicates.  
Cassette in :3 seconds  
Cassette out (Eject):5 seconds  
Check MK-12 mechanism and replace the faulty parts.
- Error4 Drum motor rotation is abnormal  
When Cassette in and Drum motor is rotating,  
D-PFD pulse does not enter over 1 second.  
error 4 indicates.  
Check the pulse at IC 501 47 pin  
Check the mechanism and replace Main micon (IC501)