

HITACHI

SERVICE MANUAL

SM0411

DV-PF4E(UK)

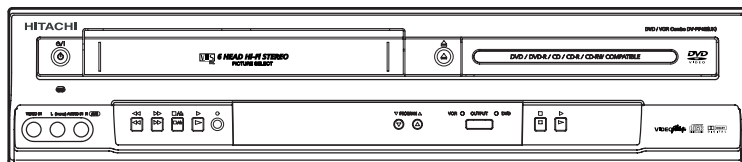

DO NOT RESELL OR DIVERT IMPROPERLY.

SPECIFICATIONS AND PARTS ARE SUBJECT TO CHANGE FOR IMPROVEMENT

DVD PLAYER & VIDEO CASSETTE RECORDER

April

2004

Digital Media Division, Tokai

CONTENTS

1 CAUTIONS FOR SAFETY IN PERFORMING

REPAIR 1-1

1-1 LASER BEAM SAFETY PRECAUTIONS	1-1
1-2 IMPORTANT SAFETY PRECAUTIONS	1-2
1-2-1 Product Safety Notice	1-2
1-2-2 Precautions during Servicing	1-2
1-2-3 Safety Check after Servicing	1-3
1-3 STANDARD NOTES FOR SERVICING	1-4
1-3-1 Circuit Board Indications	1-4
1-3-2 Instructions for Connectors	1-4
1-3-3 Pb (Lead) Free Solder	1-4
1-3-4 Instructions for Handling Semi-conductors	1-4

2 GENERAL INFORMATION 2-1

2-1 SPECIFICATIONS	2-1
2-2 COMPARISON OF MODELS	2-2
2-2-1 General	2-2
2-2-2 VCR Section	2-2
2-2-3 DVD Section	2-3
2-3 COMPARISON OF MAIN CONTROL ICS	2-4
2-4 LIST OF ABBREVIATIONS AND TERMS FOR DVD PLAYER	2-5
2-5 FUNCTION INDICATOR SYMBOLS	2-6
2-6 OPERATING CONTROLS AND FUNCTIONS	2-7

3 MAINTENANCE AND INSPECTION 3-1

3-1 TROUBLESHOOTING	3-1
3-1-1 Power Supply Section	3-1
3-1-2 DVD Section	3-4
3-1-3 VCR Section	3-8
3-2 FIRMWARE RENEWAL MODE	3-15
3-2-1 How to Update the Firmware Version	3-15
3-2-2 How to Verify the Firmware Version	3-16
3-3 STANDARD MAINTENANCE	3-17
3-3-1 Service Schedule of Components	3-17
3-3-2 Cleaning	3-18

4 DISASSEMBLY 4-1

4-1 CABINET DISASSEMBLY INSTRUCTIONS	4-1
4-1-1 Disassembly Flowchart	4-1
4-1-2 Disassembly Method	4-1
4-2 DISASSEMBLY/ASSEMBLY PROCEDURES OF DECK MECHANISM	4-6
4-3 ALIGNMENT PROCEDURES OF MECHANISM	4-15

5 ADJUSTMENT 5-1

5-1 PREPARATION FOR SERVICING	5-1
5-1-1 How to Enter the Service Mode	5-1
5-2 FIXTURE AND TAPE FOR ADJUSTMENT	5-2
5-2-1 How To Use The Fixtures And Tape	5-2
5-3 ELECTRICAL ADJUSTMENT INSTRUCTIONS	5-3
5-3-1 Test Equipment Required	5-3
5-3-2 Head Switching Position Adjustment	5-3
5-4 MECHANICAL ALIGNMENT PROCEDURES	5-4
5-4-1 Service Information	5-4
5-4-2 Tape Interchangeability Alignment	5-5
1-A. Preliminary/Final Checking and Alignment of Tape Path	5-6
1-B. X Value Alignment	5-6
1-C. Checking/Adjustment of Envelope Waveform	5-7
1-D. Azimuth Alignment of Audio/Control/Erase Head	5-8

6 EXPLODED VIEWS AND PARTS LIST 6-1

6-1 EXPLODED VIEWS	6-1
6-1-1 Cabinet Section	6-1
6-1-2 Deck Mechanism View 1 Section	6-2
6-1-3 Deck Mechanism View 2 Section	6-2
6-1-4 Deck Mechanism View 3 Section	6-3
6-2 REPLACEMENT PARTS LIST	6-4
6-2-1 Mechanical Parts List	6-4
6-2-2 Electrical Parts List	6-6

7 APPENDIX 7-1

7-1 SYSTEM CONTROL TIMING CHARTS	7-1
7-2 IC PIN FUNCTION DESCRIPTIONS	7-7
7-3 LEAD IDENTIFICATIONS	7-10

S SCHEMATIC, WIRING DIAGRAMS

S-1 Schematic Diagrams/CBA's and Test Points	S-1
S-2 Wiring Diagrams < VCR Section >	S-3
S-3 Wiring Diagrams < DVD Section >	S-4
S-4 Main 1/9 Schematic Diagram	S-5
S-5 Main 2/9, Sensor & Power SW Schematic Diagrams	S-6
S-6 Main 3/9 Schematic Diagram	S-7
S-7 Main 4/9 Schematic Diagram	S-8
S-8 Main 5/9 Schematic Diagram	S-9
S-9 Main 6/9 Schematic Diagram	S-10
S-10 Main 7/9 & DVD Open/Close Schematic Diagram	S-11
S-11 Main 8/9 Schematic Diagram	S-12
S-12 Main 9/9 Schematic Diagram	S-13
S-13 Power Supply & Junction Schematic Diagrams	S-14
S-14 Jack-A Schematic Diagram	S-15
S-15 AFV Schematic Diagram	S-16
S-16 DVD Main 1/3 Schematic Diagram	S-17
S-17 DVD Main 2/3 Schematic Diagram	S-18
S-18 IC101 Voltage Chart	S-19
S-19 DVD Main 3/3 Schematic Diagram	S-20
S-20 Waveforms	S-21

C CIRCUIT BOARD DIAGRAMS

C-1 Main CBA Top View & Sensor CBA Top View	C-1
C-2 Main CBA Bottom View	C-2
C-3 Power SW CBA Top/Bottom View & DVD Open/Close CBA Top/Bottom View	C-3
C-4 Power Supply CBA Top/Bottom View & Junction CBA Top/Bottom View	C-4
C-5 Jack-A CBA Top/Bottom View & AFV CBA Top/Bottom View	C-5

B BLOCK DIAGRAMS

B-1 Servo/System Control Block Diagram	B-1
B-2 Video Block Diagram	B-2
B-3 Audio Block Diagram	B-3
B-4 Hi-Fi Audio Block Diagram	B-4
B-5 Power Supply Block Diagram	B-5
B-6 DVD System Control/Servo Block Diagram	B-6
B-7 Digital Signal Process Block Diagram	B-7
B-8 DVD Video / Audio Block Diagram	B-8

1

CAUTION FOR SAFETY IN PERFORMING REPAIR

1-1 LASER BEAM SAFETY PRECAUTIONS

This DVD player uses a pickup that emits a laser beam.

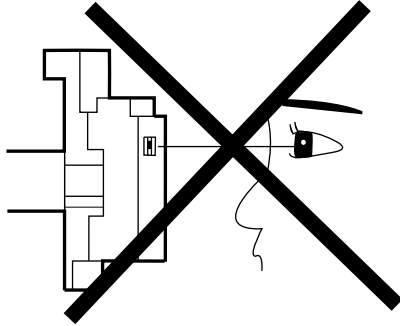

Do not look directly at the laser beam coming from the pickup or allow it to strike against your skin.

The laser beam is emitted from the location shown in the figure. When checking the laser diode, be sure to keep your eyes at least 30cm away from the pickup lens when the diode is turned on. Do not look directly at the laser beam.

Caution: Use of controls and adjustments, or doing procedures other than those specified herein, may result in hazardous radiation exposure.

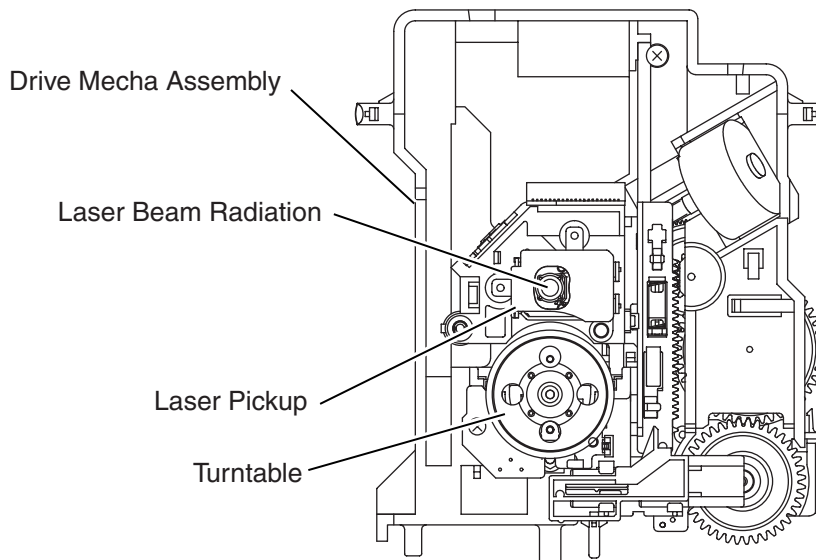

1-2 IMPORTANT SAFETY PRECAUTIONS

1-2-1 Product Safety Notice

Some electrical and mechanical parts have special safety-related characteristics which are often not evident from visual inspection, nor can the protection they give necessarily be obtained by replacing them with components rated for higher voltage, wattage, etc. Parts that have special safety characteristics are identified by a \triangle on schematics and in parts lists. Use of a substitute replacement that does not have the same safety characteristics as the recommended replacement part might create shock, fire, and/or other hazards. The Product's Safety is under review continuously and new instructions are issued whenever appropriate. Prior to shipment from the factory, our products are carefully inspected to confirm with the recognized product safety and electrical codes of the countries in which they are to be sold. However, in order to maintain such compliance, it is equally important to implement the following precautions when a set is being serviced.

1-2-2 Precautions during Servicing

- A. Parts identified by the \triangle symbol are critical for safety. Replace only with part number specified.
- B. In addition to safety, other parts and assemblies are specified for conformance with regulations applying to spurious radiation. These must also be replaced only with specified replacements.
Examples: RF converters, RF cables, noise blocking capacitors, and noise blocking filters, etc.
- C. Use specified internal wiring. Note especially:
 - 1) Wires covered with PVC tubing
 - 2) Double insulated wires
 - 3) High voltage leads
- D. Use specified insulating materials for hazardous live parts. Note especially:
 - 1) Insulation tape
 - 2) PVC tubing
 - 3) Spacers
 - 4) Insulators for transistors
- E. When replacing AC primary side components (transformers, power cord, etc.), wrap ends of wires securely about the terminals before soldering.
- F. Observe that the wires do not contact heat producing parts (heatsinks, oxide metal film resistors, fusible resistors, etc.).
- G. Check that replaced wires do not contact sharp edges or pointed parts.
- H. When a power cord has been replaced, check that 5 - 6 kg of force in any direction will not loosen it.
- I. Also check areas surrounding repaired locations.
- J. Be careful that foreign objects (screws, solder droplets, etc.) do not remain inside the set.

K. Crimp type wire connector

The power transformer uses crimp type connectors which connect the power cord and the primary side of the transformer. When replacing the transformer, follow these steps carefully and precisely to prevent shock hazards.

Replacement procedure

- 1) Remove the old connector by cutting the wires at a point close to the connector.

Important: Do not re-use a connector. (Discard it.)

- 2) Strip about 15 mm of the insulation from the ends of the wires. If the wires are stranded, twist the strands to avoid frayed conductors.
- 3) Align the lengths of the wires to be connected. Insert the wires fully into the connector.
- 4) Use a crimping tool to crimp the metal sleeve at its center. Be sure to crimp fully to the complete closure of the tool.

- L. When connecting or disconnecting the internal connectors, first, disconnect the AC plug from the AC outlet.

1-2-3 Safety Check after Servicing

Examine the area surrounding the repaired location for damage or deterioration. Observe that screws, parts, and wires have been returned to their original positions. Afterwards, do the following tests and confirm the specified values to verify compliance with safety standards.

1. Clearance Distance

When replacing primary circuit components, confirm specified clearance distance (d) and (d') between soldered terminals, and between terminals and surrounding metallic parts. (See Fig. 1-2-1)

Table 1-2-1 : Ratings for selected area

AC Line Voltage	Clearance Distance (d), (d')
220 to 240 V	$\geq 3 \text{ mm}(d)$ $\geq 6 \text{ mm}(d')$

Note: This table is unofficial and for reference only. Be sure to confirm the precise values.

2. Leakage Current Test

Confirm the specified (or lower) leakage current between B (earth ground, power cord plug prongs) and externally exposed accessible parts (RF terminals, antenna terminals, video and audio input and output terminals, microphone jacks, earphone jacks, etc.) is lower than or equal to the specified value in the table below.

Measuring Method (Power ON) :

Insert load Z between B (earth ground, power cord plug prongs) and exposed accessible parts. Use an AC voltmeter to measure across the terminals of load Z. See Fig. 1-2-2 and the following table.

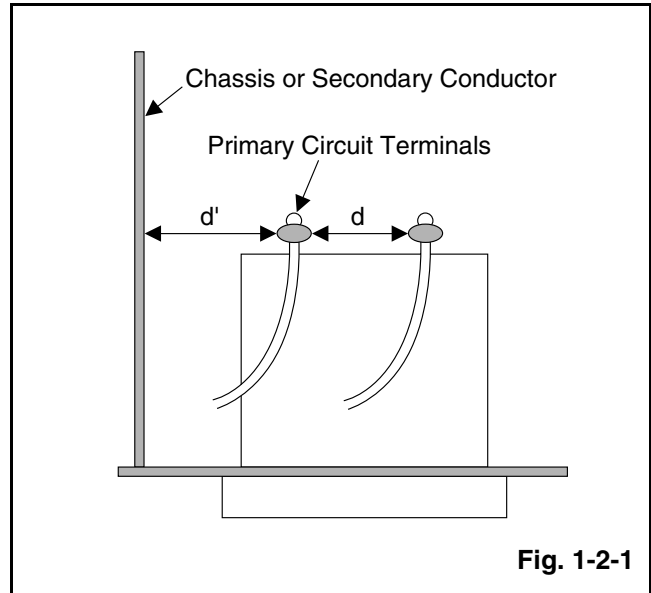

Fig. 1-2-1

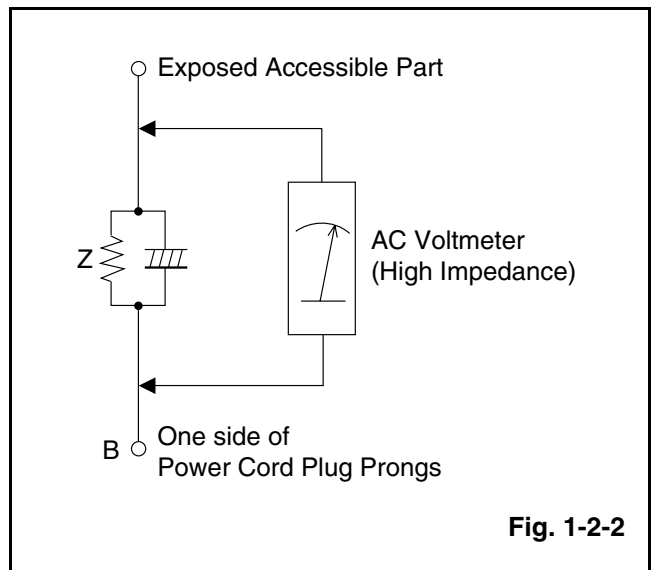

Fig. 1-2-2

Table 1-2-2: Leakage current ratings for selected areas

AC Line Voltage	Load Z	Leakage Current (i)	One side of power cord plug prongs (B) to:
220 to 240 V	2kΩ RES. Connected in parallel	$i \leq 0.7 \text{ mA AC Peak}$ $i \leq 2 \text{ mA DC}$	RF or Antenna terminals
	50kΩ RES. Connected in parallel	$i \leq 0.7 \text{ mA AC Peak}$ $i \leq 2 \text{ mA DC}$	A/V Input, Output

Note: This table is unofficial and for reference only. Be sure to confirm the precise values.

1-3 STANDARD NOTES FOR SERVICING

1-3-1 Circuit Board Indications

1. The output pin of the 3 pin Regulator ICs is indicated as shown.

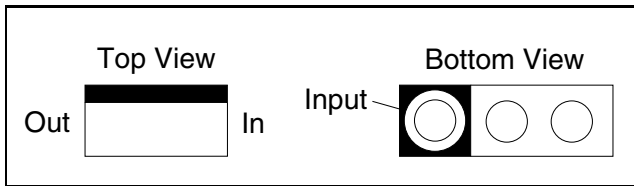

2. For other ICs, pin 1 and every fifth pin are indicated as shown.

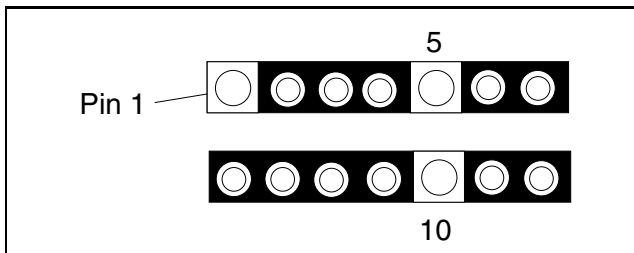

3. The 1st pin of every male connector is indicated as shown.

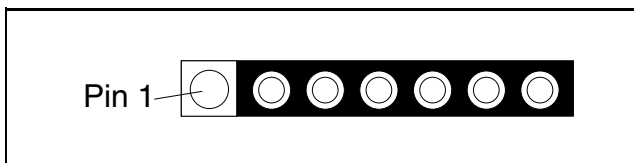

1-3-2 Instructions for Connectors

1. When you connect or disconnect the FFC (Flexible Foil Connector) cable, be sure to first disconnect the AC cord.
2. FFC (Flexible Foil Connector) cable should be inserted parallel into the connector, not at an angle.

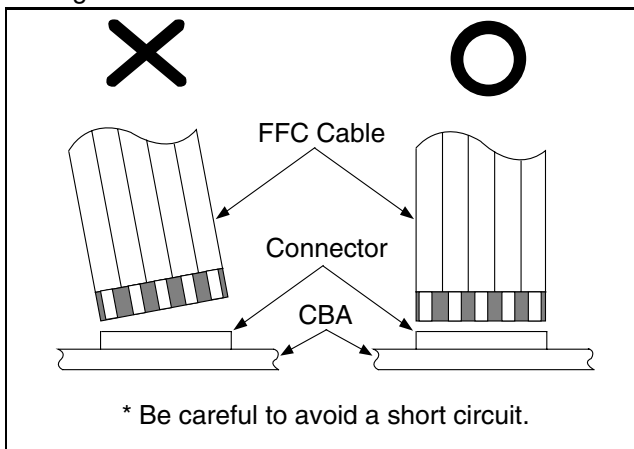

1-3-3 Pb (Lead) Free Solder

When soldering, be sure to use the Pb free solder.

1-3-4 Instructions for Handling Semi-conductors

Electrostatic breakdown of the semi-conductors may occur due to a potential difference caused by electrostatic charge during unpacking or repair work.

1. Ground for Human Body

Be sure to wear a grounding band ($1M\Omega$) that is properly grounded to remove any static electricity that may be charged on the body.

2. Ground for Workbench

- (1) Be sure to place a conductive sheet or copper plate with proper grounding ($1M\Omega$) on the workbench or other surface, where the semi-conductors are to be placed. Because the static electricity charge on clothing will not escape through the body grounding band, be careful to avoid contacting semi-conductors with your clothing.

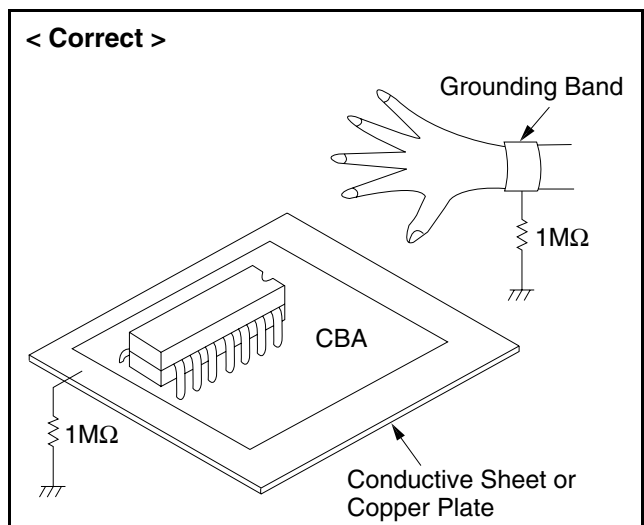
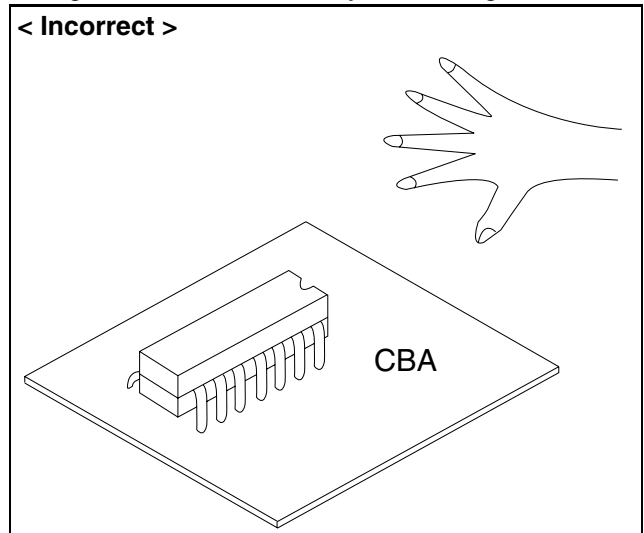

2-1 SPECIFICATIONS

ITEM		DESCRIPTION	
Video section	TV system	PAL	
	Video head	Rotating 4 heads	
	Recording system	Rotating 2 head helical scan brightness signal FM method VHS standard for methods to directly record color signal low frequency conversions	
	Audio track	Hi-Fi audio track: 2 channel Normal audio track: 1 channel	
	Tape	VHS-type videocassette	
	Tape speed	{SP}: 23.39 mm/s {LP}: 11.70 mm/s	
	Maximum record and playback time	{SP}: 4 hours (with E-240 used) {LP}: 8 hours (with E-240 used)	
	Receiving channel	CH Indication	TV Channel
		01-10	TRA-IRJ, GAP
		21-69	E21-E69
		74-78	X.Y.Z.Z+1.Z+2
		88-99, 100	S1-S20, GAP
	121-141	S21-S41	
	Reception system	Up-heterodyne	
	RF converter	RF CONVERTER	
	Converter output	UHF 22 - 69 ch, I: 35 ch	
	Timer display	24-hour system	
	Video output impedance	75 Ω	
	Video output level	1.0 V P-P	
	Audio output level	-6 dB 1 k Ω unbalance (high impedance)	
Video input level	0.5-2.0 V P-P		
Audio input level	-10 dBV		
Video S/N ratio	40 dB or more		
Audio S/N ratio	36 dB or more		
Hi-Fi audio	Frequency characteristic: 20-20,000 Hz Dynamic range: 70 dB or more		
DVD section	Disc used	DVD video disc, Music CD disc	
	Audio frequency characteristic	DVD (linear audio) 20 Hz - 22 kHz (48 kHz sampling frequency) 20 Hz - 44 kHz (96 kHz sampling frequency) Music CD 20 Hz - 20 kHz (JEITA)	
	Signal/Noise (S/N) ratio	CD: 70 dB (JEITA)	
	Dynamic range	DVD (linear audio): 70 dB, CD: 70 dB (JEITA)	
	Total distortion ratio	DVD: 0.1%, CD: 0.1%	
Terminal	Antenna input	DIN (input) terminal	
	Antenna output	DIN (output) terminal	
	Video input	SCART JACK (AV 1, 2) FRONT PIN JACK	
	Video output	SCART JACK (AV 1, 2)	
	Audio input	SCART JACK (AV 1, 2) FRONT PIN JACK	
	Audio output	SCART JACK (AV 1, 2) PIN JACK (REAR)	
	S Video output	MINI DIN 4PIN JACK (75 Ω)	
	Coaxial digital audio output	PIN JACK	
Others	Power supply	AC 220-240 V +/-10%, 50 Hz +/-0.5%	
	Power consumption	30 W (Standby: 9.0 W)	
	Back-up time	30 s	
	Temperature range for operation	5 $^{\circ}$ C - 40 $^{\circ}$ C	
	Dimensions	435(W) mm x 94(H) mm x 233(D) mm	
	Weight	3.2 kg	

2-2 COMPARISON OF MODELS

2-2-1 General

O: Yes, ---: No, ← : Same as on left

ITEM		DV-PF4E(UK)	DV-PF3E(UK)
APPEARANCE	Dimensional	435(W) x 94(H) x 233(D)mm	435(W) x 99(H) x 218(D)mm
	Weight	3.2 kg	3.8 kg
	Power Consumption	30W (standby: 9.0W)	←
	Tray Panel	Silver	←
	Color Front/Button	Silver / Silver	←
REMOTE CONTROLLER	Remote Controller Model Name	DV-RMPF4E(UK)	DV-RMPF3E(UK)
	Jog Shuttle on Remote	---	←
	TV Control	---	←

2-2-2 VCR Section

O: Yes, ---: No, ← : Same as on left

ITEM		DV-PF4E(UK)	DV-PF3E(UK)
VIDEO	Video Format	VHS	←
	Y/C Separation	Comb Filter	←
	YNR (Luminance Noise Reduction) Circuit	O	←
	New Synchronize Circuit	---	←
	Picture Control	O	←
INPUT/OUTPUT	Video/Audio Input (Rear)	2/2 (AV1/AV2)	←
	Video/Audio Input (Front)	1/1 (AV3)	←
	Video/Audio Output (Rear)	2/2 (AV1/AV2)	←
OTHER	OSD languages (VCR)	1 (English)	←
	Stereo CM Skip Feature	---	←
	Auto Clock Feature	O	←
	Number of Timer Programming	8 Program/year	←
	Self Diagnosis Function	O (4 Modes)	←
	Back-up Time	30 s	←
	SQPB	---	←
	Surge Absorber	---	←
	Auto Power Off Feature	O	←
	Local Broadcast Setting	O	←
Multi Search Feature	O (Index, Time Search, Quick Find)	←	
MECHANISM	Search Speed	SP: X5/X7 LP: X5/X11	←
	FF/REW Time (E-180 Tape)	FF: approx. 100 s, REW: approx. 100 s	←
	Head Composition	DA4+Hi-Fi SP: 2[49/49 μm] LP: 2[25/25 μm] Hi-Fi Audio: 2[28/28 μm]	←
	Head Material	SP: Ferrite LP: Ferrite Hi-Fi Audio: Ferrite	←

2-2-3 DVD Section

O: Yes, ---: No, ← : Same as on left

ITEM		DV-PF4E(UK)	DV-PF3E(UK)
GENERAL	DVD/VCD/SVCD/CD-DA	O / --- / --- / O	←
	CD-R/CD-RW/DVD-R (Video Format)	O / O / O	←
	DVD-RAM (VR Format)	---	←
	MP3	---	O
	OSD languages (DVD)	7 (English, French, Spanish, Italian, German, Dutch, Swedish)	←
	Jog Shuttle on Front	---	←
	Headphone Jack / Volume	--- / ---	←
VIDEO	PAL Disc NTSC Out	---	←
	Video Out Mode NTSC/PAL/PAL60	--- / O / O	←
	S-Video / Component / Composite	O / --- / O	←
	Video D/A Converter	10bit	←
	Black Level Select	---	←
	Picture Control	---	←
	Progressive Out	---	←
AUDIO	Audio D/A Converter	192kHz / 24bit	←
	Digital Audio Out Optical / Coaxial	O / O	←
	Dolby Digital 5.1 ch Decode	---	←
	DTS Digital Out	---	O
	Virtual Surround	O	←
	Dynamic Range Compression (Dolby Digital)	O	←
	DVD Audio	---	←
	Power on sound	---	←
TRICK PLAY	Search Speed	4 Steps	←
	Slow Speed	3 Steps	←
	IP Search (Smooth 2x Play)	O	←
	2x Play with Audio	---	←
	Step Forward / Reverse	O / ---	←
	Still Picture Select (Frame/Field)	Frame / Field / Auto	Auto Only
FEATURES	Disc Navigation	O	←
	DVD Zoom x2 / x4	O / O	←
	Program and Random Play of DVD	O	←
	A-B Repeat	O	←
	Repeat	O	←
	Last Play	---	←
	Front Panel Display Dimmer	---	←
	Screen Saver	O	←
	Auto Power Off	O (always ON)	O

2-3 COMPARISON OF MAIN CONTROL ICS

← : Same as on left

ITEM	DV-PF4E(UK)	DV-PF3E(UK)
VIDEO DRIVER	MM1637XVBE (IC102)	---
	MM1636XWRE (IC1403)	MM1567AJBE (IC1402)
VIDEO/AUDIO SIGNAL PROCESS/HEAD AMP	LA71750EM-MPB-E (IC301)	LA71750AM-MPB (IC301)
Hi-Fi AUDIO SIGNAL PROCESS	LA72648M-MPB-E (IC451)	LA72648M (IC451)
MICROCONTROLLER 8BIT SERVO/SYSTEM CONTROL	M3776AMCA-AA9GP (IC501)	M37762MCA-AC9GP / QSZAAORMB158 (IC501)
MEMORY	CAT24WC02JI / BR24L02F-WE2 (IC502)	CAT24WC02JI / BR24C02F-W (IC502)
FIP	7-BT-298N (IC611)	7-BT-292GN (IC611)
FIP DRIVER	PT6313-S-TP / SC16313 (IC612)	PT6315-S(-TP) (IC612)
VPS	LC74793JM-TRM (IC631)	←
OUTPUT SELECT	TC4053BF(N) / BU4053BCF-E2 / CD4053BCSJX / CD4053BNSR (IC751)	TC4053BF(N) / BU4053BCF-E2 (IC751)
1.2V REG	PQ070XZ5MZP (IC1002)	PQ070XF01SZ (IC1051)
3.3V REG	BA3948FP-E2 (IC1003)	PQ070XF01SZ (IC1052)
AMP	KIA4558P / NJM4558D (IC1201)	←
ERROR VOLTAGE DET	EL817(A,B) / LTV-817B-F / PS2561A-1(Q,W) (IC1001)	EL817(A,B,C) / LTV-817(B,C)-F (IC1001)
IF SIGNAL PROCESS	MSP3417G-QG-B8 / MSP3417G-QG-B8-V3 (IC1)	←

2-4 LIST OF ABBREVIATIONS AND TERMS FOR DVD PLAYER

Index	Abbreviation/Term	Explanation
A	AC3	See Dolby AC3.
C	CD-R	One type of DVD standard disc, to which writing once is possible (recordable type)
	CD-RW	One type of CD standard disc, to which writing up to 1000 times is possible
	Component video output terminals	Used for outputs of HDTV video signal format. Since signals for brightness and colors are independently handled for components signals (Y: luminance signal; PR/PB: chrominance signals), degrading of image will be reduced.
D	Dolby AC3	Audio coding format developed by Dolby Laboratories in U.S, also simply referred to as AC3 format: Supports 5-channel full-range sound and one channel for sub-woofer sound playback.
	D terminal	This terminal, specified by EIAJ (currently JEITA), can automatically switch "digital hi-vision" programs of BS digital broadcast, and "digital standard broadcast" of current image quality. A tuner and TV can easily be connected to the D terminal. There are 5 types of D terminal, depending on the different format of video signal passing through the D terminal.
	DTS	Digital Theater System: Sound system as for movie theaters developed by US Digital Theater Systems, Inc. The number of channels provided by DTS is the same for Dolby AC3.
	DVD	Digital Versatile Disc. A huge amount of digital data for video (movie) and audio can be recorded on this disc, whose size is the same as CD.
	DVD-Audio	One type of DVD standard disc, on which high-quality audio can be recorded
	DVD-R	One type of DVD standard disc, to which writing once is possible (recordable type)
	DVD-RAM	One type of DVD standard disc, to which writing up to 100,000 times is possible
	DVD-ROM	One type of DVD standard disc, to which data for computer can be recorded
	DVD-RW	One type of DVD standard disc, to which writing up to 1000 times is possible
	DVD-Video	One type of DVD standard disc, on which high-quality video and audio can be recorded
	DVD Video Format	Video recording/playback standard that applies to DVD-Video, DVD-R and DVD-RW
	DVD Video Recording Format	Video recording/playback standard that applies to DVD-RAM and DVD-RW: This allows versatile editing functions, differing from the DVD Video Format.
	DVD Forum	International organization that formulates the technical standards of DVD
E	EIAJ	Electronic Industries Association of Japan: An organization of manufacturers of consumer electronic devices, industrial electronic devices and electronic components, established in April 1948. EIAJ merged with JEIDA (Japan Electronic Industry Development Association) in November 2000 to become JEITA (Japan Electronics and Information Technology Industries Association).
J	JPEG	Joint Photographic Expert Group: International standard format for compressing still images.
L	Linear PCM	Linear Pulse Code Modulation: LPCM is a format that digitizes analog audio signal during recording and converts it back to analog signal during playback.
M	MPEG	Moving Picture Experts Group: Standard related to compression of digital video and audio. MPEG2 is a higher standard of MPEG and is applied to video (movie) requiring higher quality.
	MPEG Audio Layer 2	One of three audio compression standards (layers 1-3) defined by MPEG
	MP3	MPEG1 Audio Layer-3: Audio data digital compression technology.
P	Progressive playback function	This function converts interlaced images to non-interlaced images and displays them. It can play back 24-frame/second images included in DVD movie software, etc.
S	SDMI	Secure Digital Music Initiative: This conference was established by hardware makers, the Recording Industry Association of America (RIAA) and music industry companies, to protect copyrights of musical compositions.
V	Virtual surround	This technology localizes sound at any position using only two front speakers, by subjecting the L and R signals to matrix operation. It uses the four transfer functions from L/R speakers located at specified positions to both ears of listener located in a specified position, taking into account the shape of head and the effect of earlobes, and the two transfer functions from any position to both ears.

2-5 FUNCTION INDICATOR SYMBOLS

Note:

The following symbols will appear on the indicator panel to indicate the current mode or operation of the VCR. On-screen modes will also be momentarily displayed on the tv screen when you press the operation buttons.

MODE	INDICATOR ACTIVE
When reel and capstan mechanism is not functioning correctly	“▲ R” is displayed on a TV screen. (Refer to Fig. 1.)
When tape loading mechanism is not functioning correctly	“▲ T” is displayed on a TV screen. (Refer to Fig. 2.)
When cassette loading mechanism is not functioning correctly	“▲ C” is displayed on a TV screen. (Refer to Fig. 3.)
When the drum is not working properly	“▲ D” is displayed on a TV screen. (Refer to Fig. 4.)
P-ON Power safety detection	“▲ P” is displayed on a TV screen. (Refer to Fig. 5.)

TV screen

Note:

OSD for mechanical error will be displayed for 5 sec. after the mechanical error occurs.

When reel and capstan mechanism is not functioning correctly When the drum is not working properly

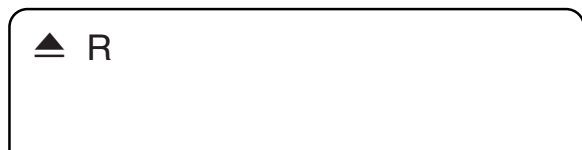

Fig. 1

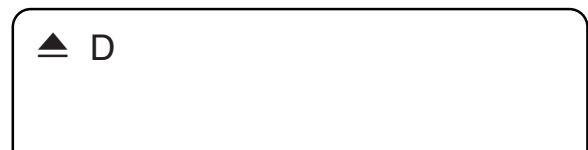

Fig. 4

When tape loading mechanism is not functioning correctly P-ON Power safety detection

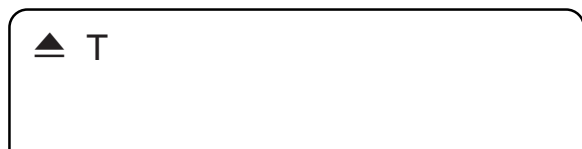

Fig. 2

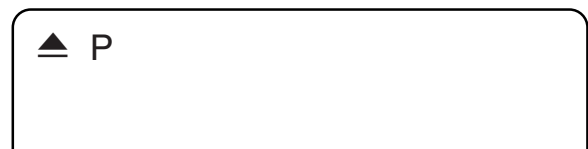

Fig. 5

When cassette loading mechanism is not functioning correctly

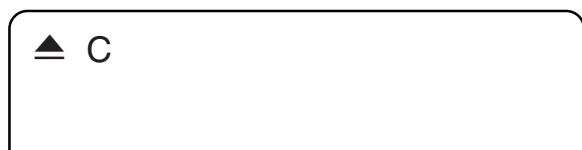

Fig. 3

2-6 OPERATING CONTROLS AND FUNCTIONS

DVD / VCR SWITCHING

Since this product comprises DVD and VCR players, it is necessary to select the correct output mode.

SWITCHING TO DVD MODE

Press **DVD** on the remote control.
(Verify that the DVD OUTPUT Light is lit.)

SWITCHING TO VCR MODE

Press **VCR** on the remote control.
(Verify that the VCR OUTPUT Light is lit.)

NOTE

- Pressing only **OUTPUT** on the front panel does not switch the mode of the remote control. You always need to select the correct mode on the remote control too.

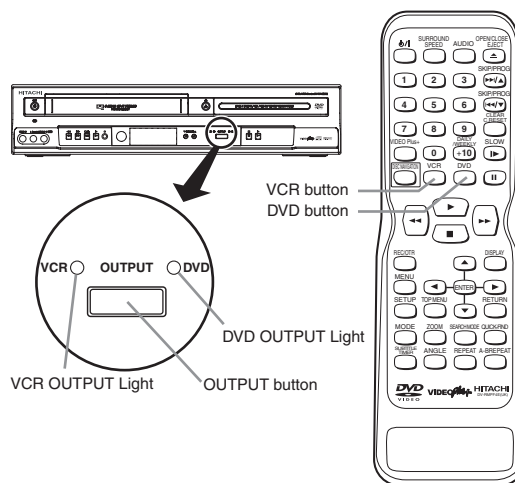

FUNCTIONAL OVERVIEW

FRONT PANEL

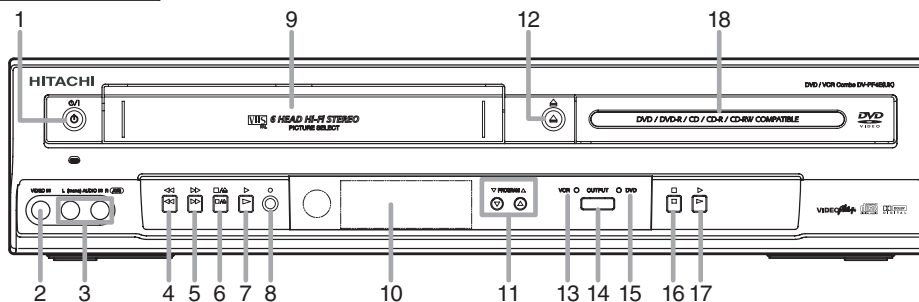

- ⏻/I (POWER/STANDBY)**
Press to turn the power on and off.
- VIDEO In Jack**
Connect a video cable coming from the video out jack of a camcorder, another VCR, or a video source (laser disc player, camcorder, etc.) here.
- AUDIO In Jacks**
Connect audio cables coming from the audio out jacks of a camcorder, another VCR, or an audio source here.
- ◀◀ (REW) [VCR]**
Press to rewind the tape, or to view the picture rapidly in reverse during the playback mode (Rewind Search).
- ▶▶ (F.FWD) [VCR]**
Press to rapidly advance the tape, or view the picture rapidly in forward during playback. (Forward Search).
- /▲ (STOP/EJECT) [VCR]**
STOP
Press to stop the tape motion.
EJECT
Press to remove the tape from the VCR.
- ▶ (PLAY) [VCR]**
Press to begin playback.
- (REC) [VCR]**
Press once to start a recording. Press repeatedly to start a One Touch Recording.
- CASSETTE COMPARTMENT**
- Display, Remote Sensor Window**
- PROGRAM (▲/▼) Buttons**
In VCR mode, press to change TV programmes on the VCR; press to adjust the tracking during normal or slow motion playback; press to remove vertical jitter in a Still picture.
- ▲ (OPEN/CLOSE) [DVD]**
Press to insert discs into or remove them from the tray.
- VCR OUTPUT Light**
This light appears when the VCR output mode is selected. You can only watch tapes when the green VCR OUTPUT light is on. To make the green VCR OUTPUT light come on, VCR on the remote control or OUTPUT on the front panel.
- OUTPUT**
Press to select DVD mode or VCR mode. You can switch the output mode either by pressing OUTPUT on the front panel, or by pressing DVD or VCR on the remote control. However, **if you press OUTPUT on the front panel first, you need to re-select the corresponding mode by pressing DVD or VCR on the remote control.**
- DVD OUTPUT Light**
This light appears when the DVD output mode is selected. You can only watch DVDs when the green DVD OUTPUT Light is on. To make the green DVD OUTPUT light come on, press DVD on the remote control or OUTPUT on the front panel.
- (STOP) [DVD]**
Stops operation of the disc.
- ▶ (PLAY) [DVD]**
Press to begin playback.
- Disc loading tray**

FUNCTIONAL OVERVIEW

REAR PANEL

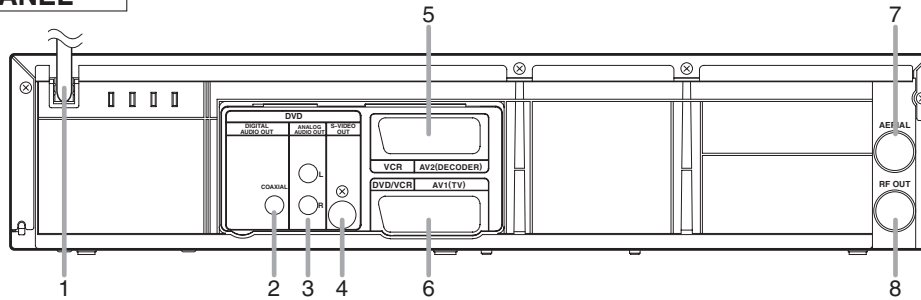

- 1. MAIN (AC Power Cord)**
Connect to a standard AC plug.
- 2. DIGITAL AUDIO OUT JACKS**
Use a coaxial digital cable to connect to a compatible Dolby Digital receiver. Use to connect to a Dolby Digital decoder or MPEG decoder.
- 3. AUDIO OUT JACKS (ANALOG Left/Right)**
Connect to the Audio input jacks of A/V-compatible TV or wide screen TV, Stereo system.
- 4. S-VIDEO OUT JACK (DVD Only)**
Use the S-Video cable to connect this jack to the S-Video jack on your A/V-compatible TV or wide screen TV for a higher quality picture.
- 5. EURO AV2 (DECODER) JACK**
Use the Euro Audio/Video cable to connect this jack to the 21 pin scart jack on your decoder.

- 6. EURO AV1 (TV) JACK**
Use the Euro Audio/Video cable to connect this jack to the 21 pin scart jack on your A/V-compatible TV or wide screen TV for a best quality picture.
- 7. AERIAL Jack**
Connect your antenna, Cable Box, or Direct Broadcast System.
- 8. RF OUT Jack**
Use the supplied aerial cable to connect this jack to the ANTENNA IN Jack on your TV.

Caution: Do not touch the inner pins of the jacks on the rear panel. Electrostatic discharge may cause permanent damage to the DVD/VCR.

Display

DVD

VCR

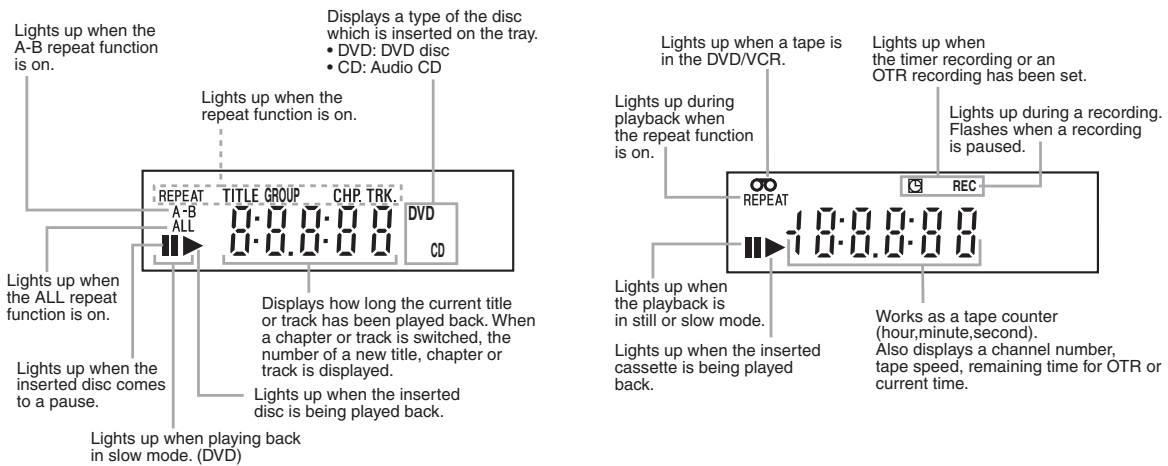

Displays During Operation

	No disc inserted or cannot read		Loading the Disc
	Tray open		When a disc is being played back
	Tray closed		

FUNCTIONAL OVERVIEW

Remote Controller

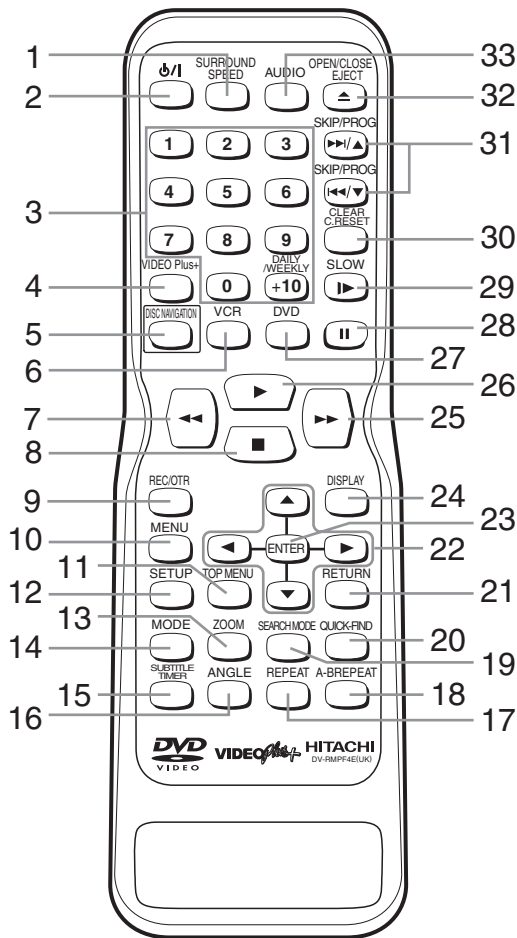

Loading the Batteries

1. Open the battery compartment cover.

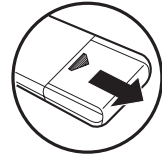

2. Insert two AA batteries, with each one oriented correctly.

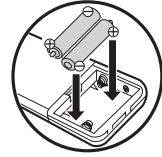

3. Close the cover.

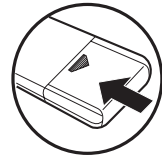

















Cautions On Batteries

- Use "AA" (R6P) batteries in this remote control unit.
- Replace the batteries with new ones approximately once a year, though this depends on the frequency with which the remote control unit is used.
- If the remote control unit does not operate from close to the main unit, replace the batteries with new ones, even if less than a year has passed.
- The included battery is only for verifying operation. Replace it with a new battery as soon as possible.
- When inserting the batteries, be careful to do so in the proper direction, following the ⊕ and ⊖ marks in the remote control unit's battery compartment.
- To prevent damage or battery fluid leakage:
 - Do not use a new battery with an old one.
 - Do not use two different types of batteries such as alkaline and manganese.
 - Do not short-circuit, disassemble, heat or dispose of batteries in flames.
- Remove the batteries when not planning to use the remote control unit for a long period of time.
- If the batteries should leak, carefully wipe off the fluid from the inside of the battery compartment, then insert new batteries.

FUNCTIONAL OVERVIEW













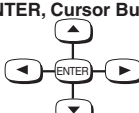

Remote Controller

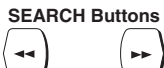
Buttons on remote control work in different ways for DVD, Audio CD and VCR:
Refer to the following table for correct use.

		DVD Mode	VCR Mode
1	SURROUND/ SPEED Button 	<ul style="list-style-type: none"> To activate virtual surround. 	<ul style="list-style-type: none"> To select the recording speed.
2	POWER/STANDBY Button 	<ul style="list-style-type: none"> Turns the DVD/VCR on and off. 	<ul style="list-style-type: none"> Turns the DVD/VCR on and off.
3	Number Buttons 	<ul style="list-style-type: none"> To select chapter or title directly. (DVD) To select track directly. (CD) 	<ul style="list-style-type: none"> To select channel. To set the VIDEO Plus+ number. <p>DAILY / WEEKLY button</p> <ul style="list-style-type: none"> Use when you record using VIDEO Plus+ system.
4	VIDEO Plus+ Button 	—	<ul style="list-style-type: none"> To programme timer recording with the VIDEO Plus+ system.
5	DISC NAVIGATION Button 	<ul style="list-style-type: none"> The first scenes of each chapter of the title being played will be displayed. (DVD) 	—
6	VCR Button 	—	<ul style="list-style-type: none"> To select the VCR output mode. To use the remote control in VCR mode.
7 25	SEARCH Buttons 	<ul style="list-style-type: none"> Allows you to search forward/backward through a disc. To begin slow forward/backward through a disc. (DVD) 	<ul style="list-style-type: none"> Allows you to search forward/backward through a tape.
8	STOP Button 	<ul style="list-style-type: none"> To stop playback. 	<ul style="list-style-type: none"> To stop playback or record.
9	RECORD/ONE-TOUCH-RECORDING Button 	—	<ul style="list-style-type: none"> To start a recording.
10	MENU Button 	<ul style="list-style-type: none"> Brings up the Menu on a disc. (DVD) 	<ul style="list-style-type: none"> Brings up the VCR Menu.
11	TOP MENU Button 	<ul style="list-style-type: none"> Brings up the Top Menu on a disc. (DVD). 	—
12	SETUP Button 	<ul style="list-style-type: none"> Brings up the DVD player's Setup menu. 	—
13	ZOOM Button 	<ul style="list-style-type: none"> To magnify part of picture x2/x4. (DVD) 	—
14	MODE Button 	<ul style="list-style-type: none"> To set virtual surround on/off. To arrange the playing order or play randomly. (CD) 	—
15	SUBTITLE/TIMER Button 	<ul style="list-style-type: none"> Accesses various subtitles on a disc. (DVD) 	<ul style="list-style-type: none"> Press to put the VCR into standby mode for a timer recording.
16	ANGLE Button 	<ul style="list-style-type: none"> Accesses various camera angles on a disc. (DVD) 	—

FUNCTIONAL OVERVIEW

Tour of the remote controller

		DVD Mode	VCR Mode
17	REPEAT Button 	<ul style="list-style-type: none"> Allows you to repeat play a chapter or title. (DVD) Allows you to repeat play a track or all. (CD) 	—
18	A-B REPEAT Button 	<ul style="list-style-type: none"> Marks a segment to repeat between A and B. (DVD/CD) 	—
19	SEARCH MODE Button 	<ul style="list-style-type: none"> To search chapter or title. (DVD) To search track. (CD) To search time. (DVD/CD) To rapidly return to a location of disc. Search the markers. (DVD/CD) 	—
20	QUICK-FIND 	—	<ul style="list-style-type: none"> To search and confirm the contents of the recorded programme(s)
21	RETURN Button 	<ul style="list-style-type: none"> Returns to a previous menu. (DVD) 	—
22 23	ENTER, Cursor Buttons 	<ul style="list-style-type: none"> Moves the cursor and determines its position. 	<ul style="list-style-type: none"> Moves the cursor and determines its position. Cannot use the ENTER button.
24	DISPLAY Button 	<ul style="list-style-type: none"> Displays the current disc mode. 	<ul style="list-style-type: none"> Displays the current time, tape counter, channel.
25 7	SEARCH Buttons 	<ul style="list-style-type: none"> Allows you to search forward/backward through a disc. To begin slow forward/backward through a disc. (DVD) 	<ul style="list-style-type: none"> Allows you to search forward/backward through a tape.
26	PLAY Button 	<ul style="list-style-type: none"> Begin disc play. 	<ul style="list-style-type: none"> Begin tape playback.
27	DVD Button 	<ul style="list-style-type: none"> To select the DVD output mode. To use the remote control in DVD mode. 	—
28	PAUSE/STEP Button 	<ul style="list-style-type: none"> Pause disc play. Advances playback one frame at a time. (DVD) 	<ul style="list-style-type: none"> Pause tape playback or recording. Advances playback one frame at a time.
29	SLOW Button 	—	<ul style="list-style-type: none"> To view the tape in slow motion.
30	CLEAR/C.RESET Button 	<ul style="list-style-type: none"> Clear the markers. Clear the number that is entered incorrectly. Removes status No. in programme input. (CD) 	<ul style="list-style-type: none"> To reset the tape counter.
31	SKIP/PROG Buttons 	<ul style="list-style-type: none"> To skip chapters. (DVD) To skip tracks. (CD) 	<ul style="list-style-type: none"> Press to control the TV programmes.
32	OPEN/CLOSE/EJECT Button 	<ul style="list-style-type: none"> To open or close the disc tray. 	<ul style="list-style-type: none"> Press to eject the video cassette from the VCR.
33	AUDIO Button 	<ul style="list-style-type: none"> Accesses various audio functions on a disc. (DVD) To select STEREO, L-CH or R-CH. (CD) 	<ul style="list-style-type: none"> To select STEREO, L-CH R-CH, or normal.

3-1 TROUBLESHOOTING

Troubleshooting is how to service for the specifying malfunction or poor parts. Detect malfunction or poor parts and service as the following charts.

3-1-1 Power Supply Section

FLOW CHART NO.1

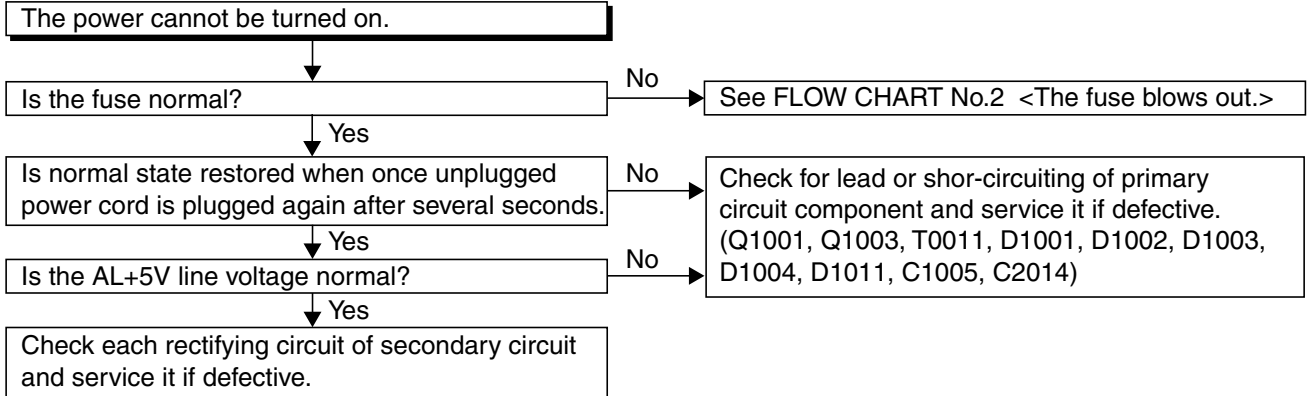

FLOW CHART NO.2

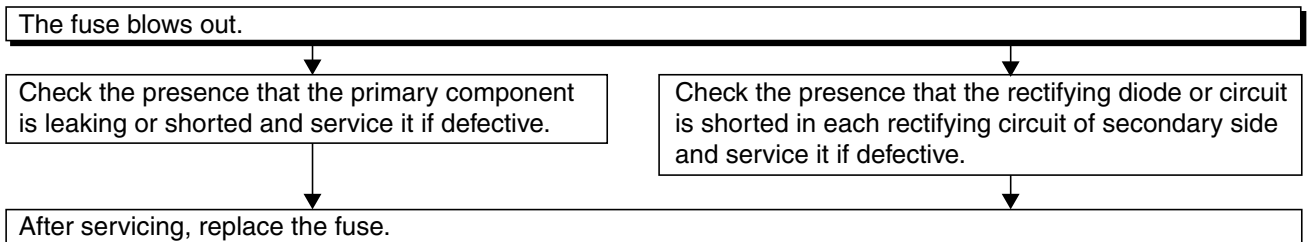

FLOW CHART NO.3

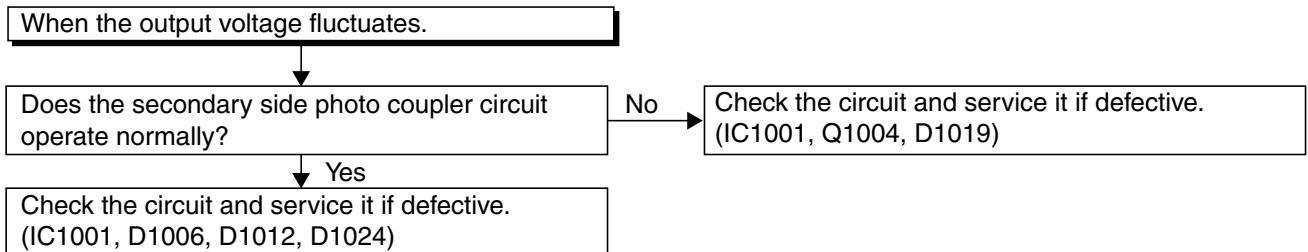

FLOW CHART NO.4

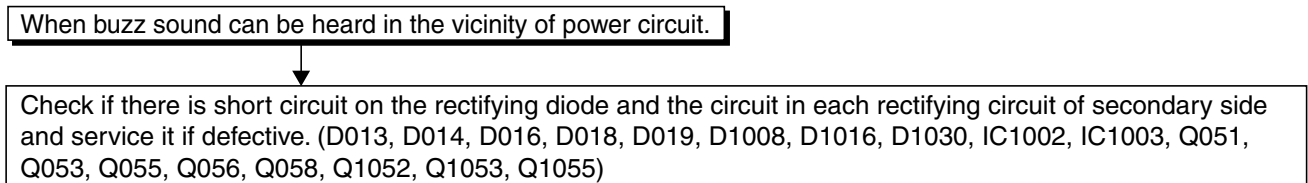

FLOW CHART NO.5

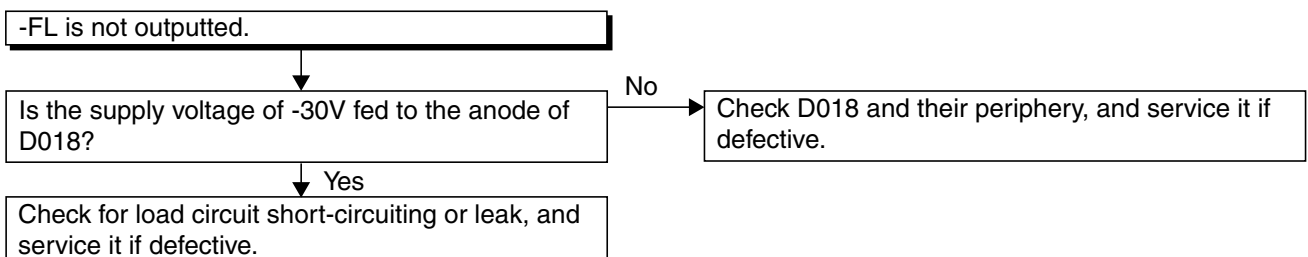

FLOW CHART NO.6

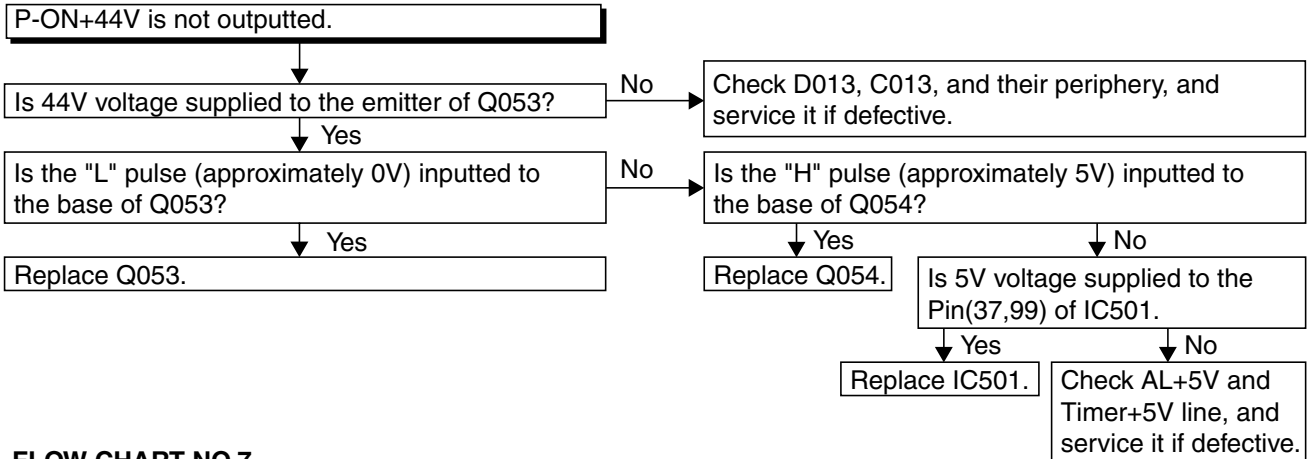

FLOW CHART NO.7

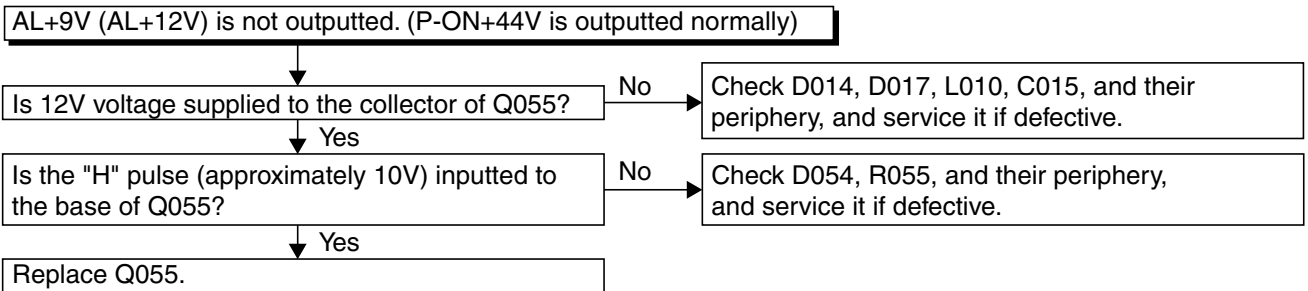

FLOW CHART NO.8

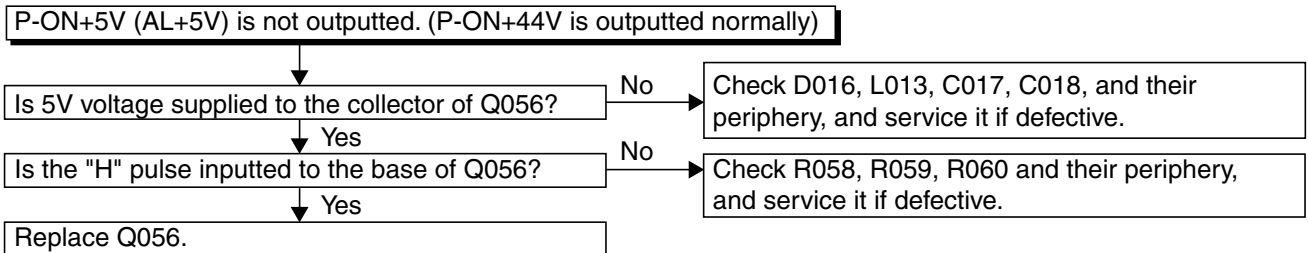

FLOW CHART NO.9

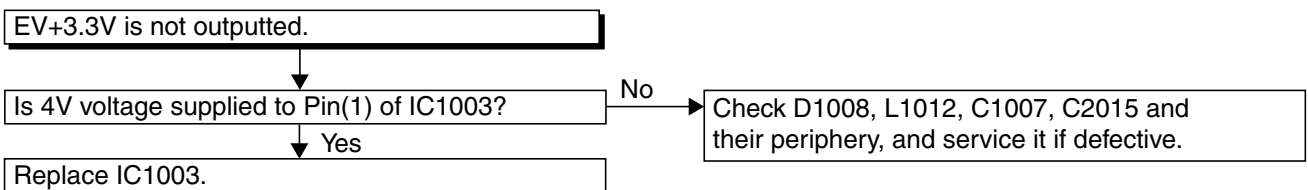

FLOW CHART NO.10

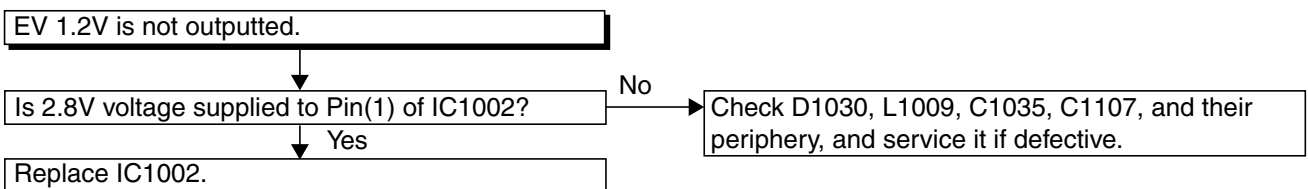

FLOW CHART NO.11

DVD-P-ON+12V is not outputted. (AL+12V is outputted normally.)

Is the "L" pulse (approximately 0V) outputted to the collector of Q1054?

No

Check Q1054 and PWRCON line, and service it if defective.

Yes

Replace Q1053.

FLOW CHART NO.12

DVD-P-ON+5V is not outputted. (AL+5V is outputted normally.)

Is the "H" pulse (approximately 6V) inputted to the base of Q1055?

No

See FLOW CHART NO.11. <DVD-P-ON+12V is not outputted. >

Yes

Replace Q1055.

FLOW CHART NO.13

DVD-P-ON+3.3V is not outputted. (EV+3.3V is outputted normally.)

Is the "H" pulse (approximately 4V) inputted to the base of Q1052?

No

See FLOW CHART NO.11. <DVD-P-ON+12V is not outputted. >

Yes

Replace Q1052.

FLOW CHART NO.14

The fluorescent display tube does not light up.

Is 3.3V voltage supplied to Pin(6, 24) of IC612?

No

Check the EV+3.3V line and service it if defective.

Yes

Is approximately -24V to -28V voltage supplied to Pin(15) of IC612?

No

Check the -FL line and service it if defective.

Yes

Is there approximately 500kHz oscillation to Pin(26) of IC612?

No

Check R618, IC612 and their periphery, and service it if defective.

Yes

Are the filament voltage applied between (1, 2) and (29, 30) of the fluorescent display tube? Also negative voltage applied between these pins and GND?

No

Check the power circuit, D1016, D1017, R1040, C1018 and their periphery, and service it if defective.

Yes

Replace the fluorescent display tube (IC611).

3-1-2 DVD Section

FLOW CHART NO.1

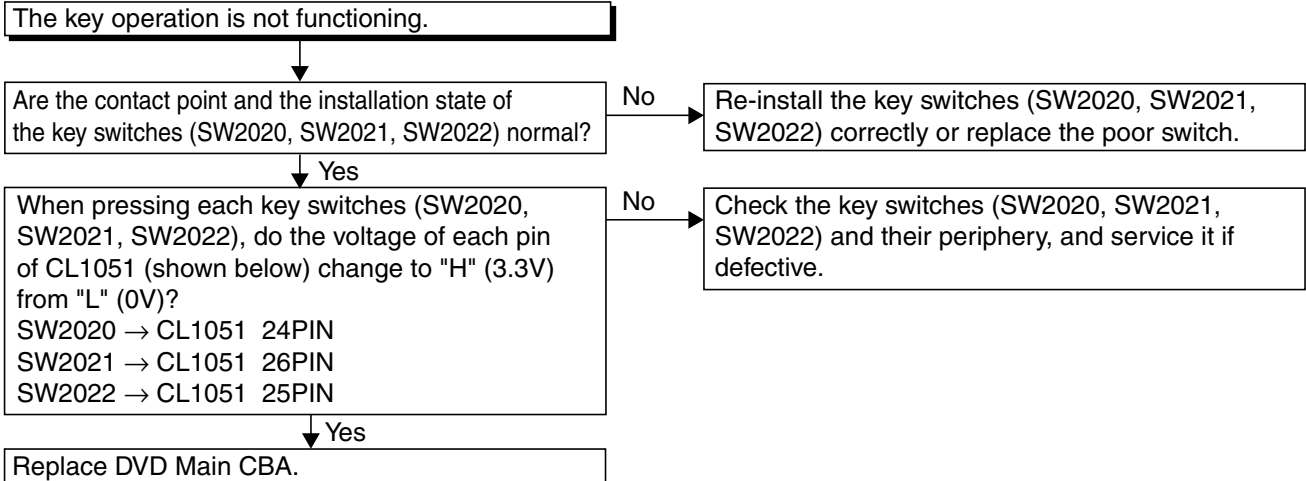

FLOW CHART NO.2

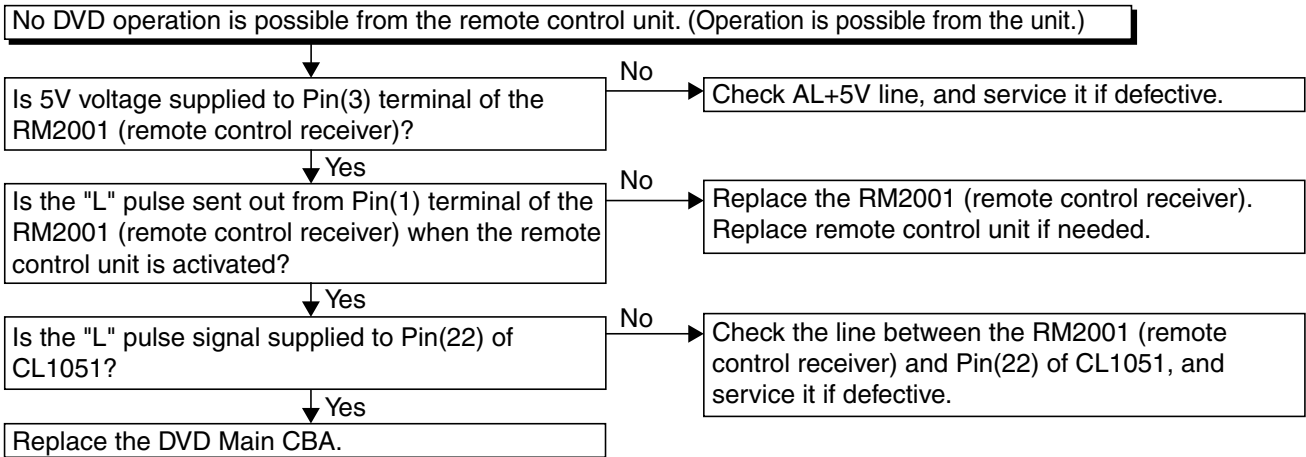

FLOW CHART NO.3

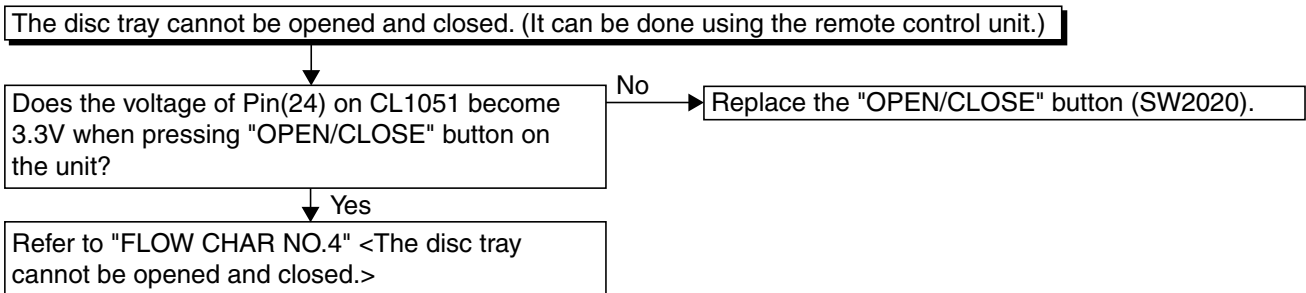

FLOW CHART NO.4

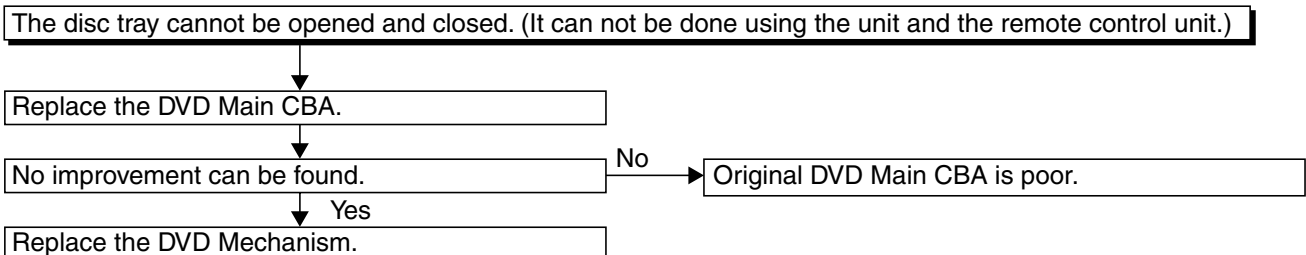

FLOW CHART NO.5

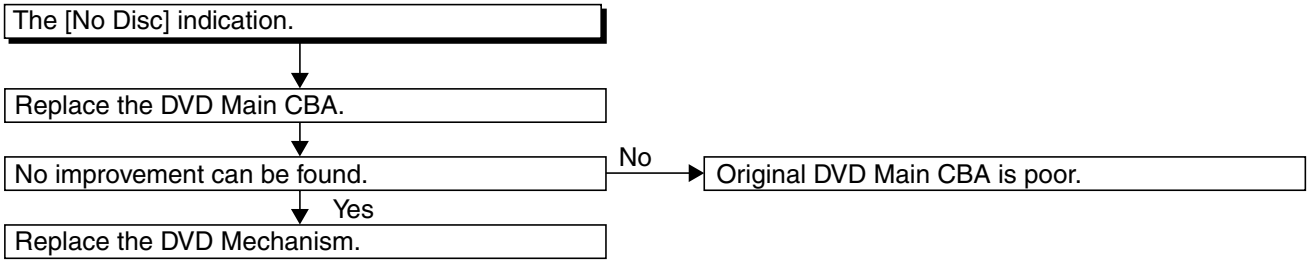

FLOW CHART NO.6

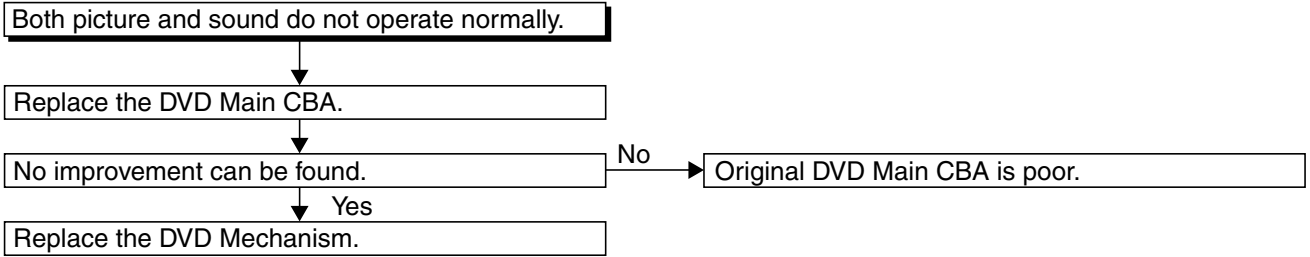

FLOW CHART NO.7

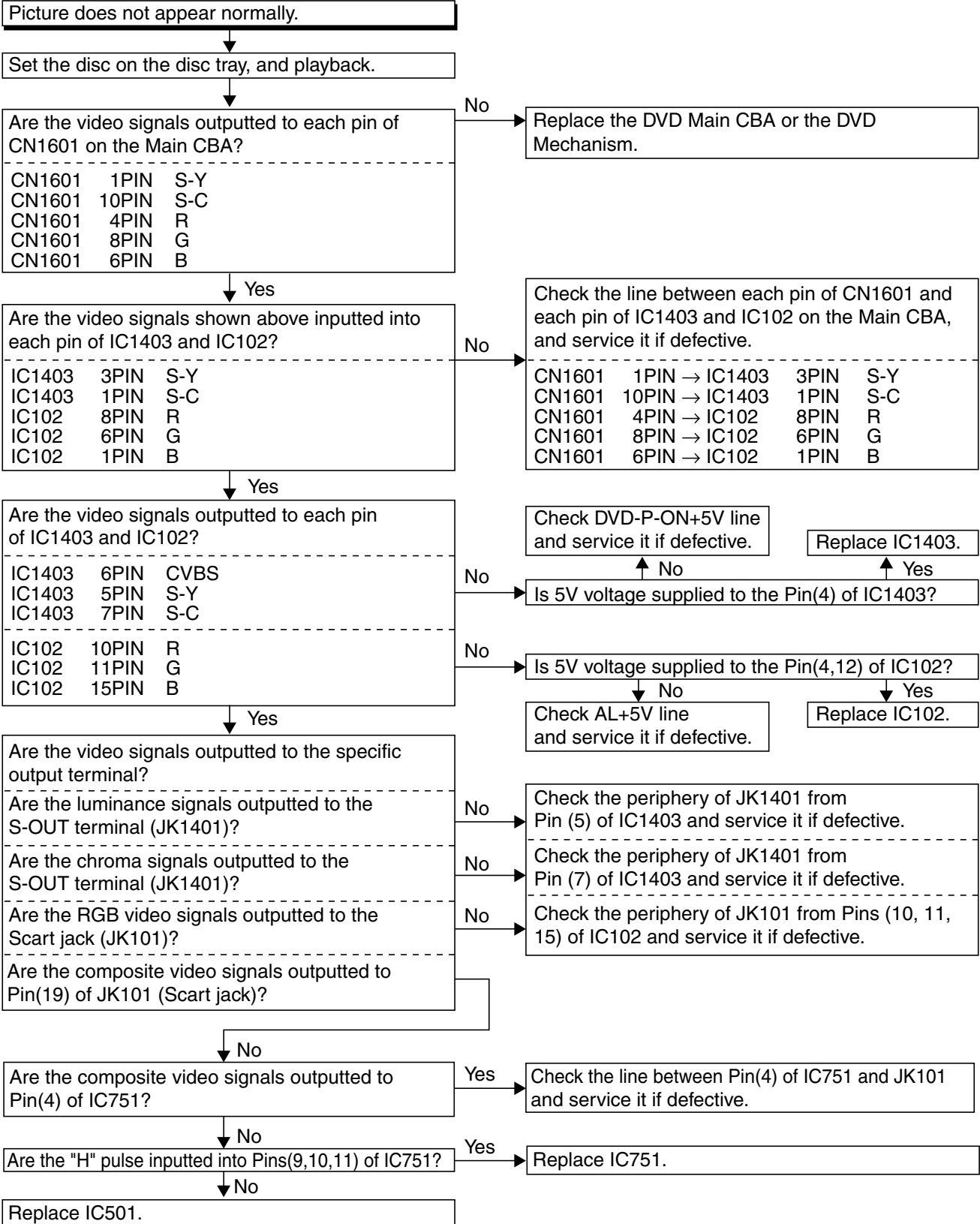

FLOW CHART NO.8

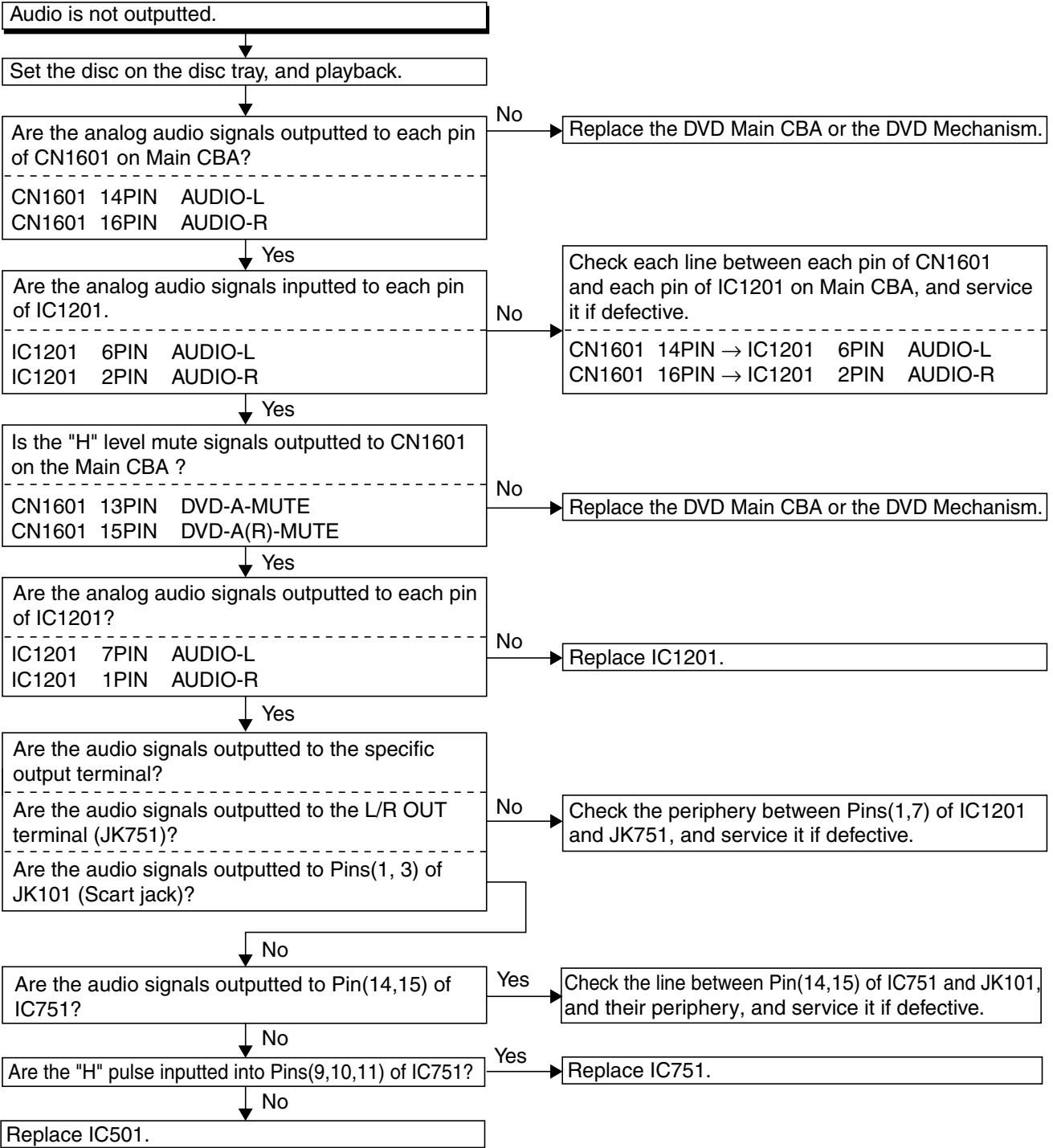

3-1-3 VCR Section

FLOW CHART NO.1

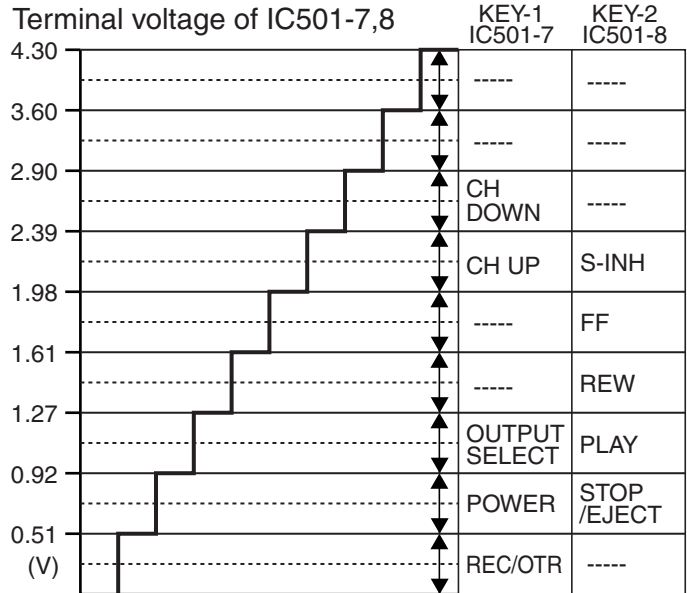
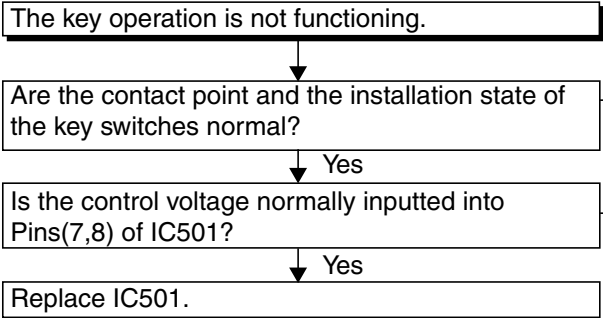

FLOW CHART NO.2

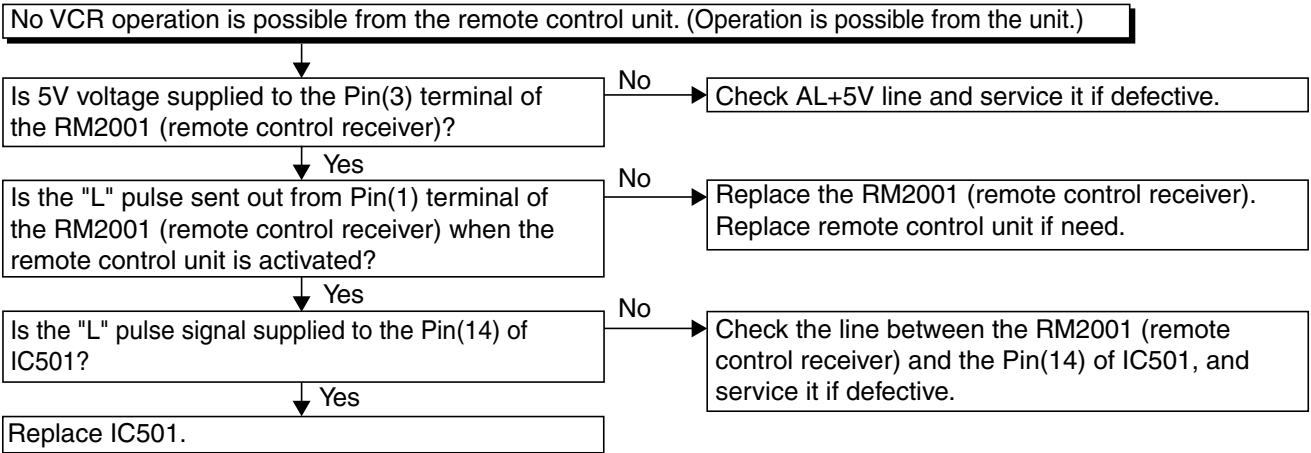

FLOW CHART NO.3

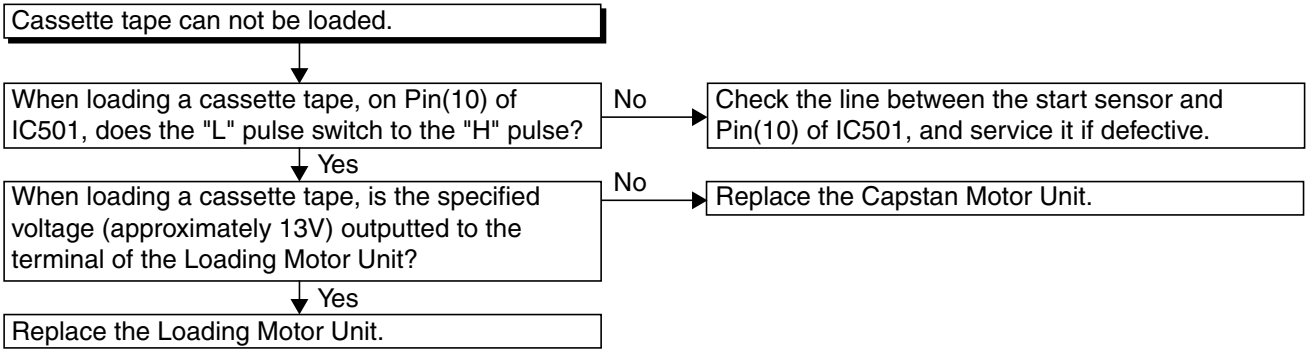

FLOW CHART NO.4

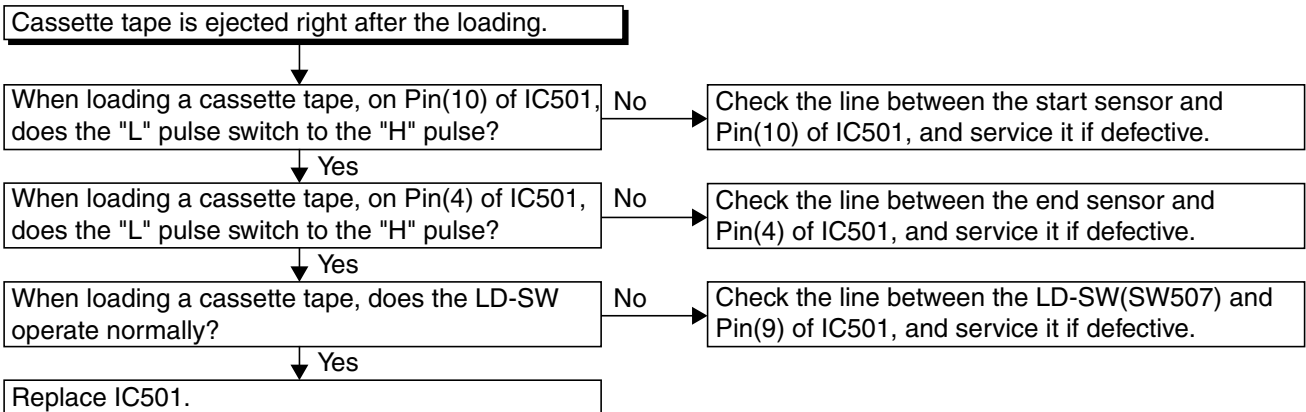

FLOW CHART NO.5

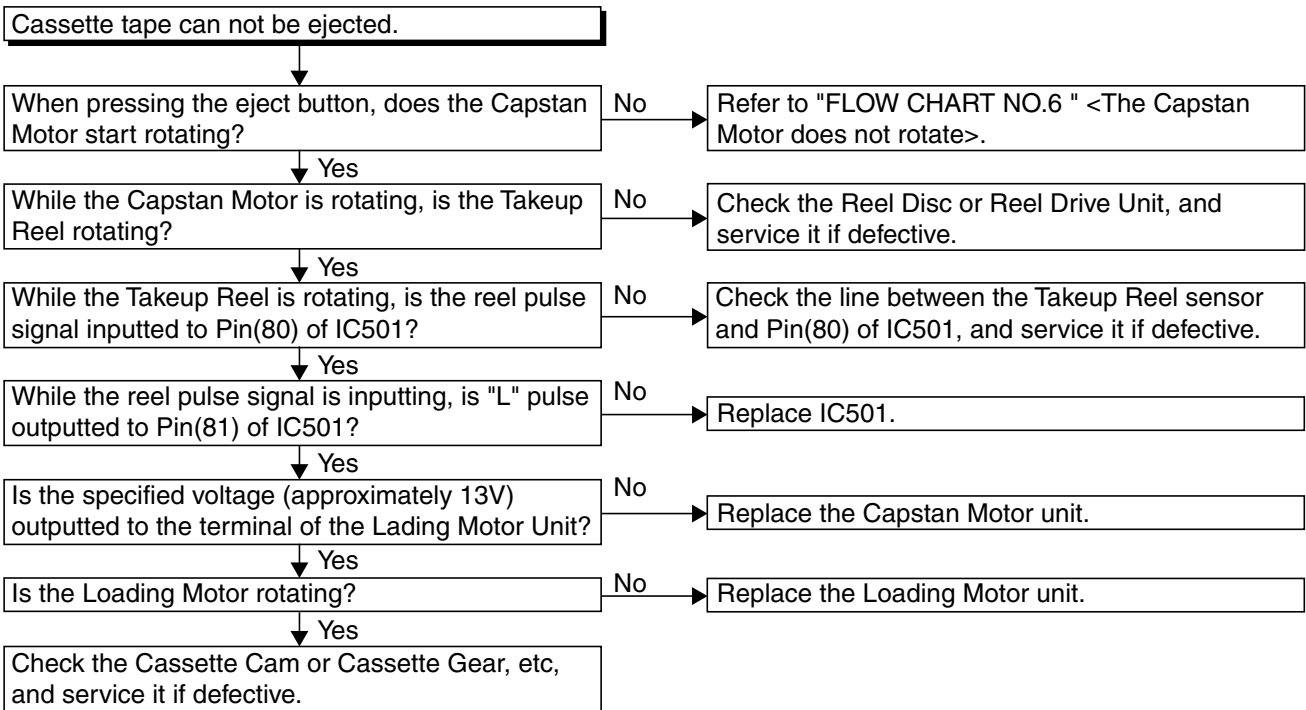

FLOW CHART NO.6

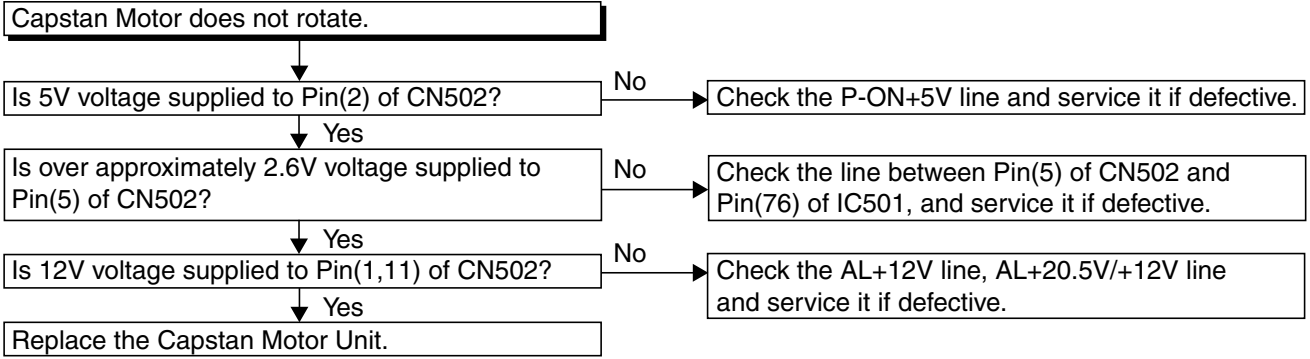

FLOW CHART NO.7

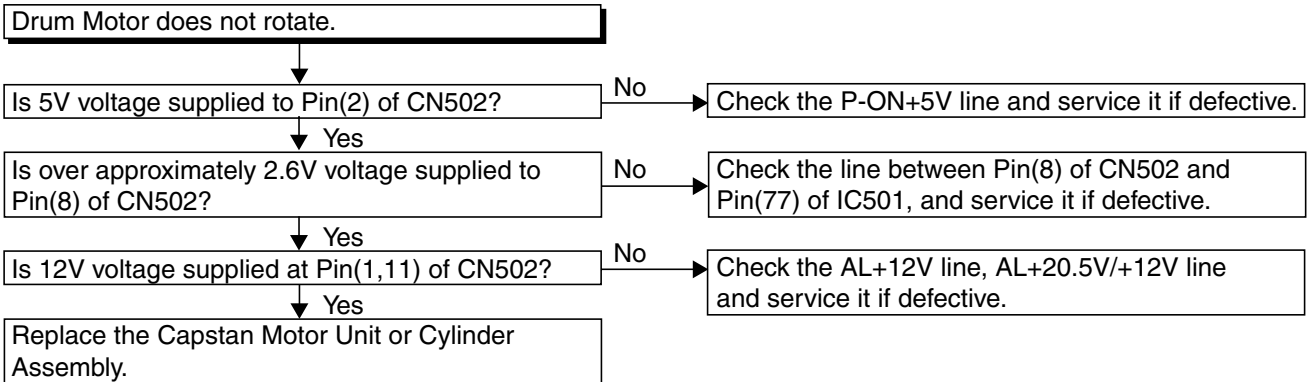

FLOW CHART NO.8

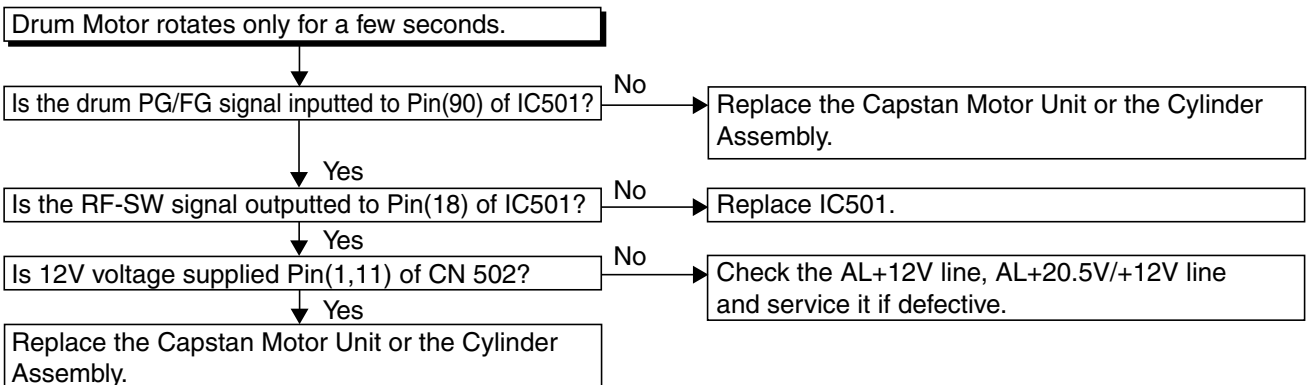

FLOW CHART NO.9

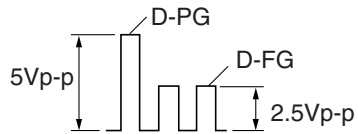
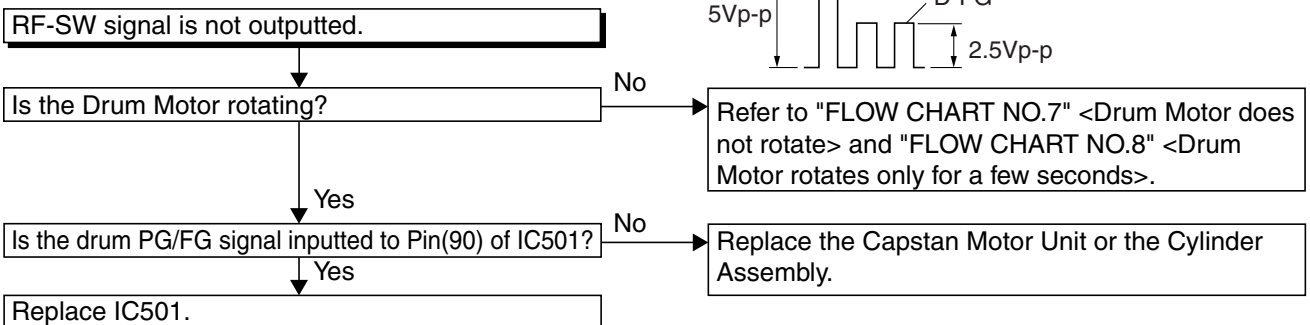

FLOW CHART NO.10

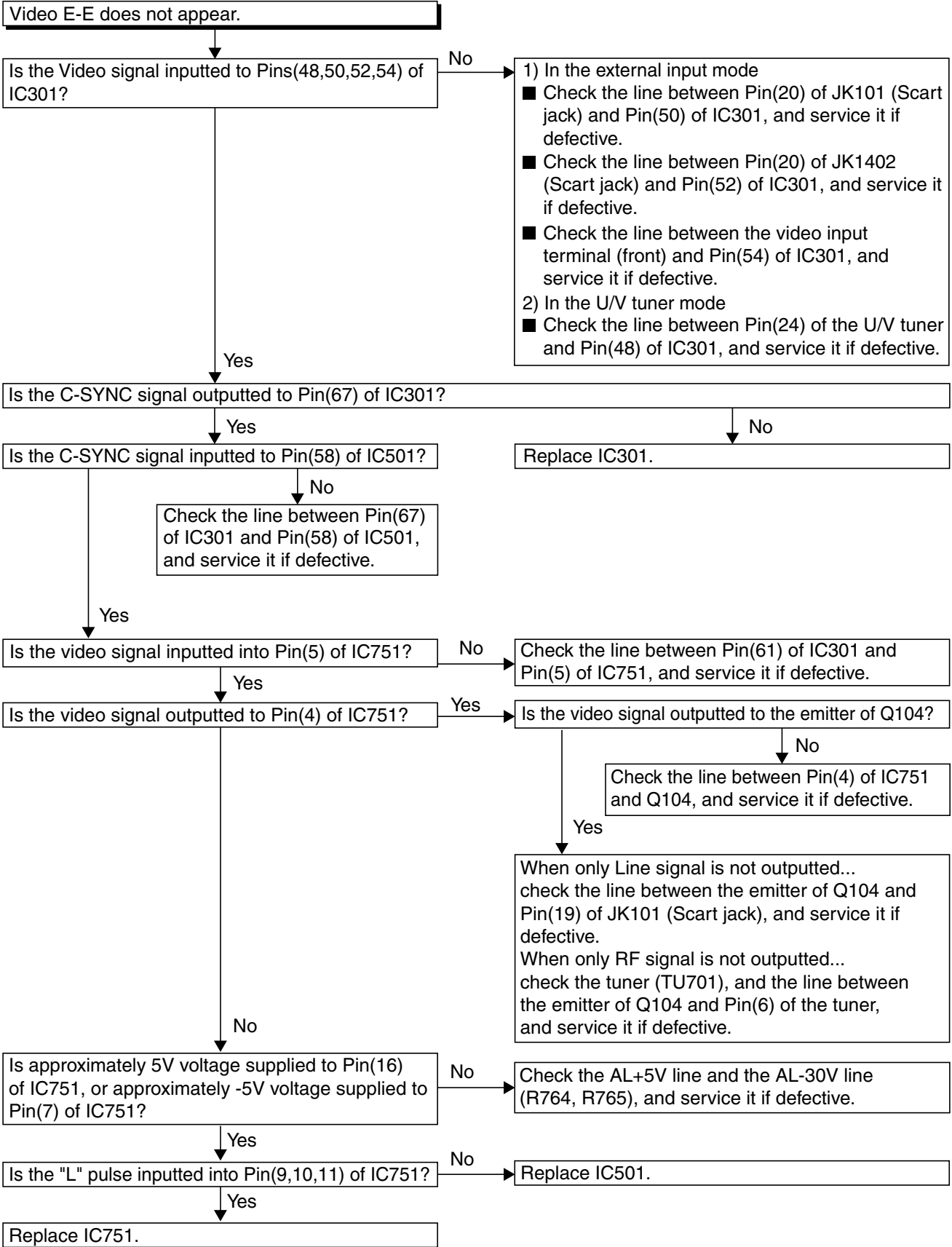

FLOW CHART NO.11

Hi-Fi E-E audio does not operate normally.

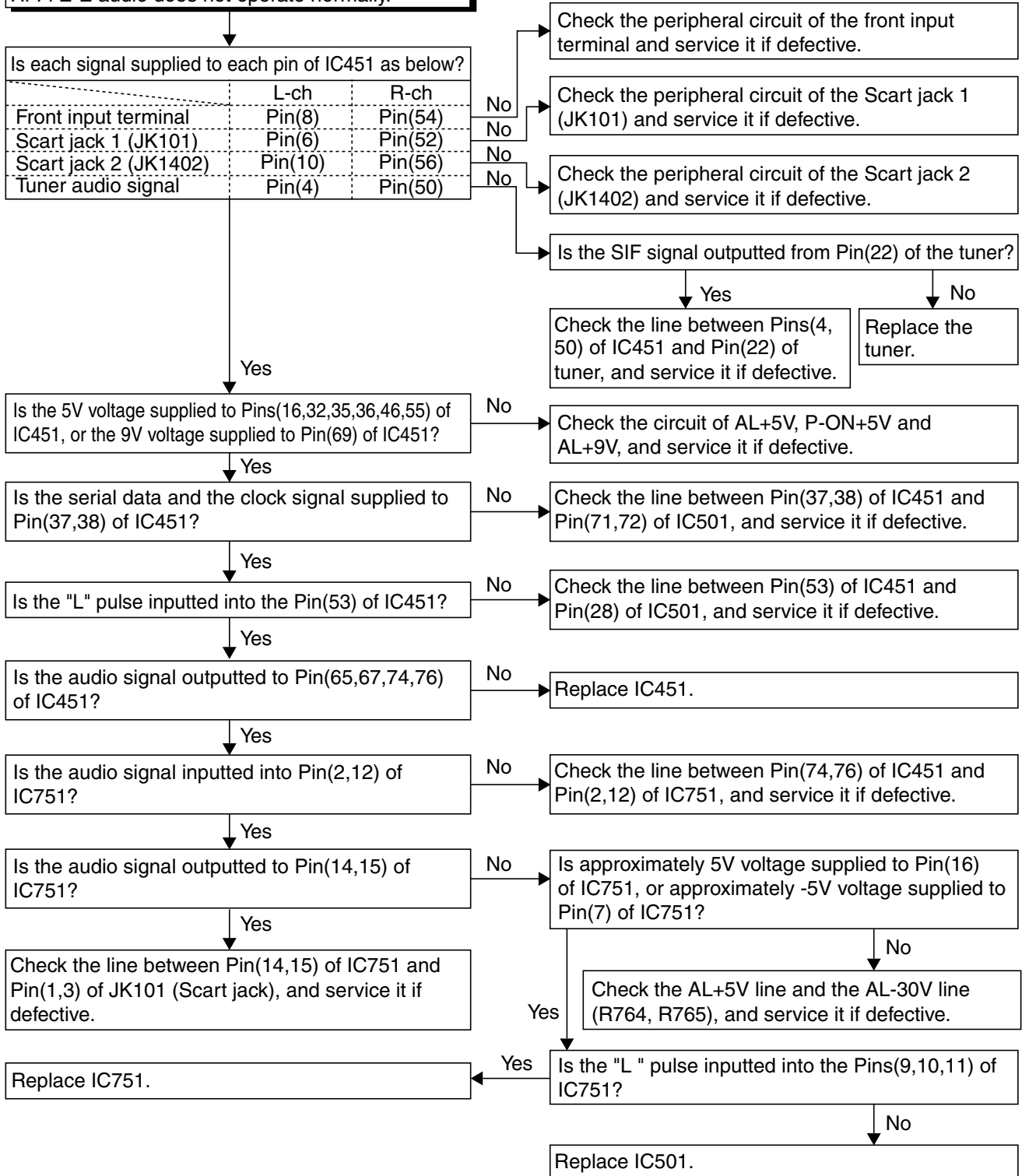

FLOW CHART NO.12

Hi-Fi audio can not be recorded normally. (E-E mode is normal.)

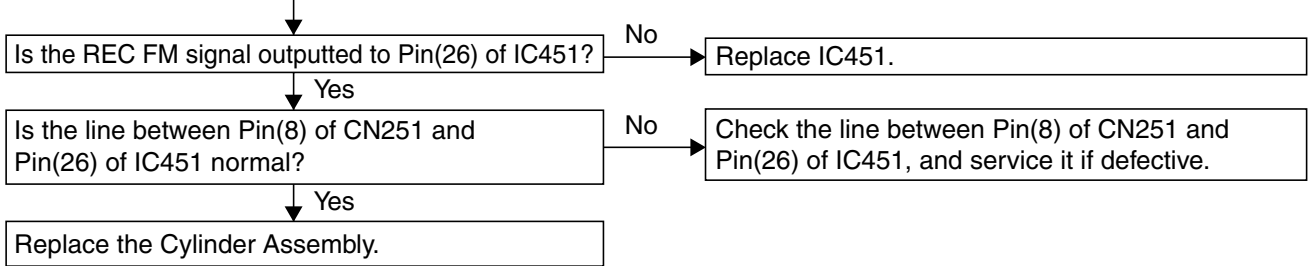

FLOW CHART NO.13

Hi-Fi audio can not be played back normally. (Hi-Fi E-E mode is normal.)

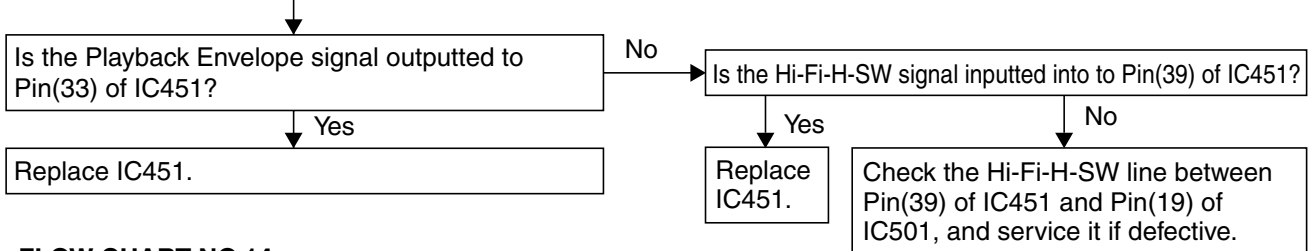

FLOW CHART NO.14

Hi-Fi audio can not be recorded normally in the linear audio mode. (E-E mode is normal.)

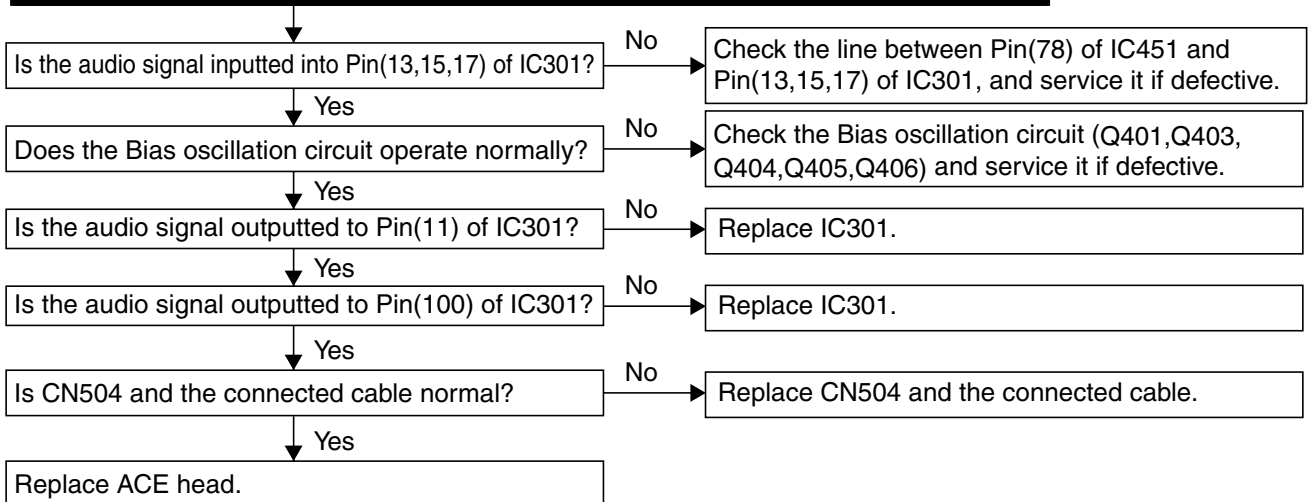

FLOW CHART NO.15

Hi-Fi audio can not be playbacked normally in the linear audio mode. (E-E mode is normal.)

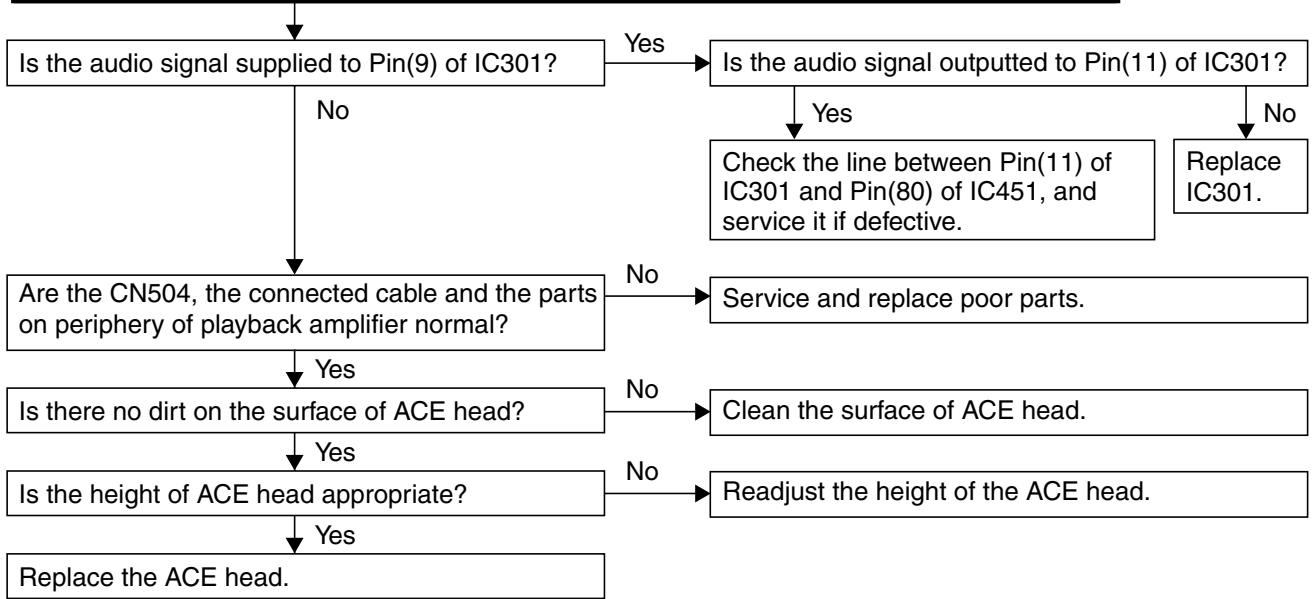

3-2 FIRMWARE RENEWAL MODE

3-2-1 How to Update the Firmware Version

Note:

If the firmware has been changed, etc., we will use Service News, etc. to report on how to obtain new firmware data and create an upgraded disc.

1. Turn the power on and remove the disc on the tray.
2. To put the DVD player into version up mode, press [9], [8], [7], [6], and [SEARCH MODE] buttons on the remote control unit in that order. The tray will open automatically. Fig. a appears on the screen and Fig. b appears on the VFD.

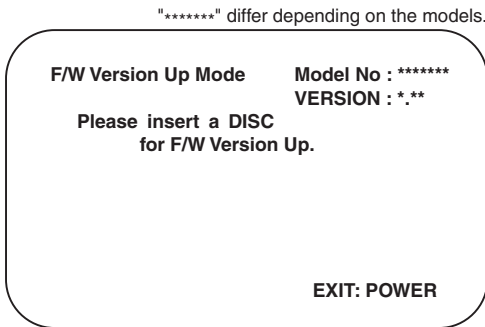

Fig. a Version Up Mode Screen

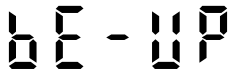

Fig. b VFD in Version Up Mode

The DVD player can also enter the version up mode with the tray open. In this case, Fig. a will be shown on the screen while the tray is open.

3. Load the disc for version up.
4. The DVD player enters the F/W version up mode automatically. Fig. c appears on the screen and Fig. d appears on the VFD. If you enter the F/W for different models, "Disc Error" will appear on the screen, then the tray will open automatically.

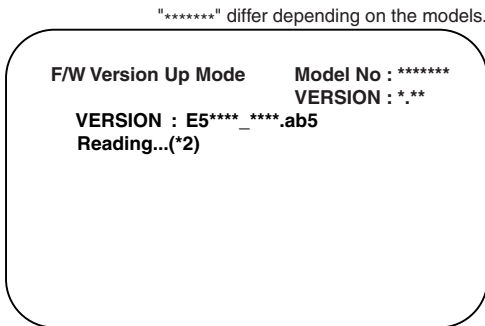

Fig. c Programming Mode Screen



Fig. d VFD in Programming Mode (Example)

The appearance shown in (*2) of Fig. c is described as follows:

No.	Appearance	State
1	Reading...	Sending files into the memory
2	Erasing...	Erasing previous version data
3	Programming...	Writing new version data

5. After programming is finished, the tray opens automatically. Fig. e appears on the screen and the checksum in (*3) of Fig. e appears on the VFD. (Fig. f)

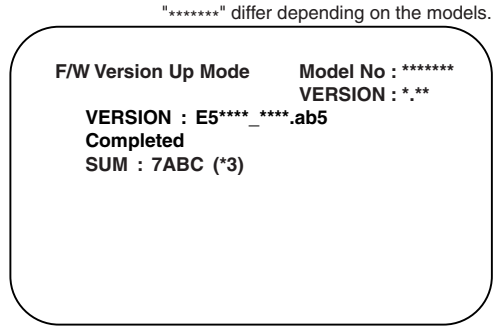

Fig. e Completed Program Mode Screen



Fig. f VFD upon Finishing the Programming Mode (Example)

At this time, no buttons are available.

6. Remove the disc on the tray.
7. Unplug the AC cord from the AC outlet. Then plug it again.
8. Turn the power on by pressing the [POWER] button and the tray will close.
9. Press [1], [2], [3], [4], and [DISPLAY] buttons on the remote control unit in that order. Fig. g appears on the screen.

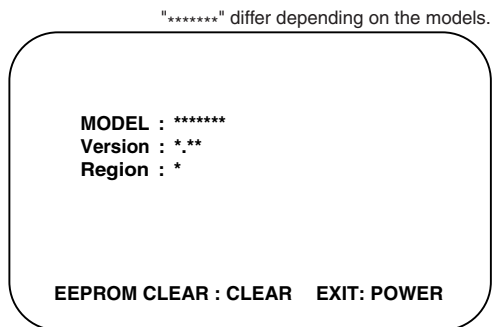

Fig. g

10. Press [CLEAR/C.RESET] button on the remote control unit.

Fig. h appears on the screen.

"*****" differ depending on the models.

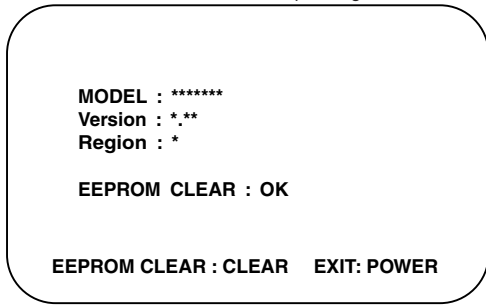

Fig. h

When "OK" appears on the screen, the factory default will be set. Then the firmware renewal mode is complete.

11. To exit this mode, press [⏻/I] button.

3-2-2 How to Verify the Firmware Version

1. After making sure that no disc is in unit, turn the power on.
2. Press [1], [2], [3], [4], and [DISPLAY] buttons on the remote control unit in that order. The Firmware version appears on the VFD and TV screen.
3. Turn the power off to reset the unit.

3-3 STANDARD MAINTENANCE

3-3-1 Service Schedule of Components

This maintenance chart shows you the standard of replacement and cleaning time for each part. Because those may replace depending on environment and purpose for use, use the chart for reference.

H: Hours ○: Cleaning ●: Replace

Deck		Periodic Service Schedule			
Ref.No.	Part Name	1,000 H	2,000 H	3,000 H	4,000 H
B2	Cylinder Assembly	○	●	○	●
B3	Loading Motor Assembly			●	
B8	Pulley Assembly		●		●
B587	Tension Lever Assembly		●		●
B31	ACE Head Assembly			●	
B573, B574	Reel (SP)(D2), Reel (TU)(D2)			●	
B37	Capstan Motor		●		●
B52	Cap Belt		●		●
B73	FE Head			●	
B133, B134	Idler Gear, Idler Arm		●		●
B410	Pinch Arm(A) Assembly		●		●
B414	M Brake (SP) Assembly		●		●
B416	M Brake (TU) Assembly		●		●
B525	LDG Belt		●		●
B569 (2 head only)	Cam Holder		●		●
B593 (4 head, 4 head HiFi only)	Cam Holder Assembly		●		●

Notes:

1. Clean all parts for the tape transport (Upper Drum with Video Head / Pinch Roller / ACE Head / FE Head) using 90% Isopropyl Alcohol.
2. After cleaning the parts, do all DECK ADJUSTMENTS.
3. For the reference numbers listed above, refer to Deck Exploded Views.

3-3-2 Cleaning

Cleaning of Video Head

Clean the head with a head cleaning stick or chamois cloth.

Procedure

1. Remove the top cabinet.
2. Put on a glove (thin type) to avoid touching the upper and lower drum with your bare hand.
3. Put a few drops of 90% Isopropyl alcohol on the head cleaning stick or on the chamois cloth and, by slightly pressing it against the head tip, turn the upper drum to the right and to the left.

Notes:

1. The video head surface is made of very hard material, but since it is very thin, avoid cleaning it vertically.
2. Wait for the cleaned part to dry thoroughly before operating the unit.
3. Do not reuse a stained head cleaning stick or a stained chamois cloth.

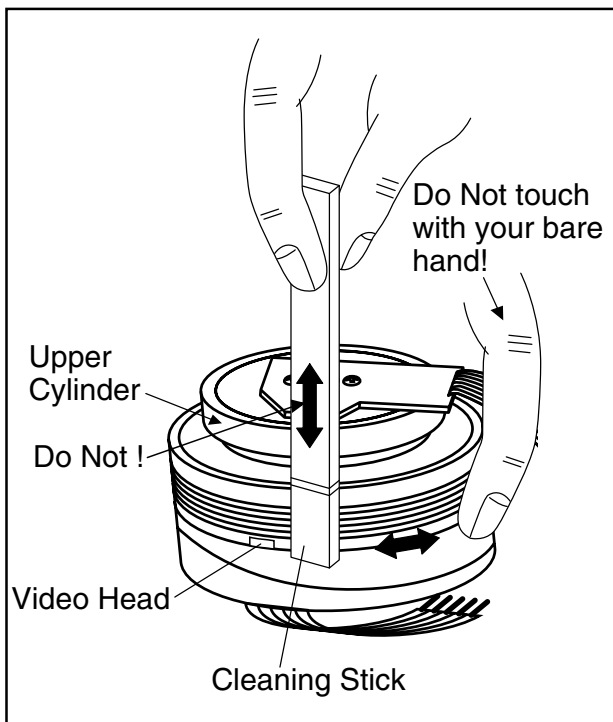

Cleaning of ACE Head

Clean the head with a cotton swab.

Procedure

1. Remove the top cabinet.
2. Dip the cotton swab in 90% isopropyl alcohol and clean the ACE Head. Be careful not to damage the upper drum and other tape running parts.

Notes:

1. Avoid cleaning the ACE Head vertically.
2. Wait for the cleaned part to dry thoroughly before operating the unit or damage may occur.

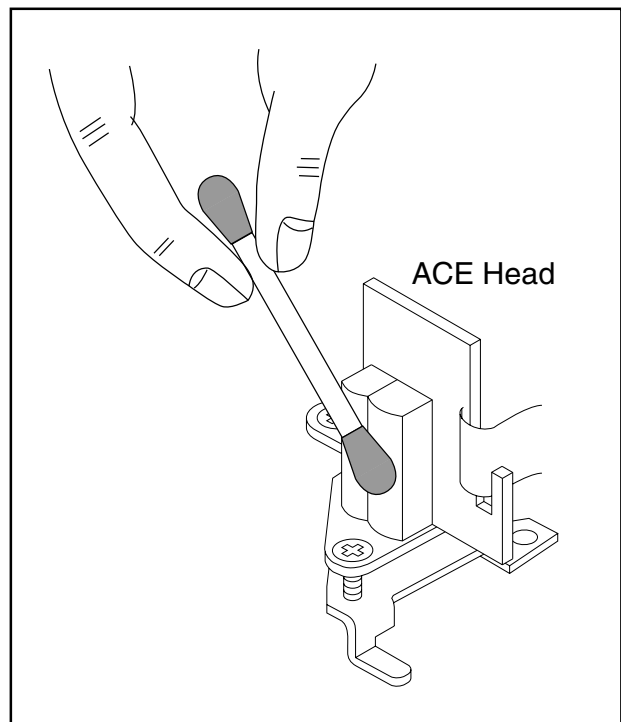

4-1 CABINET DISASSEMBLY INSTRUCTIONS

4-1-1 Disassembly Flowchart

This flowchart indicates the disassembly steps to gain access to item(s) to be serviced. When reassembling, follow the steps in reverse order. Bend, route, and dress the cables as they were originally.

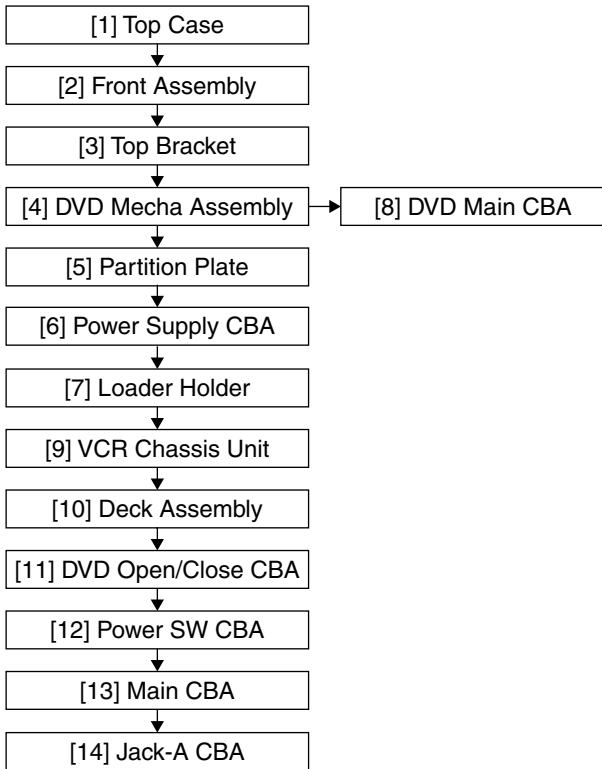

ID/LOC. No.	PART	REMOVAL		
		Fig. No.	REMOVE/*UNHOOK/ UNLOCK/RELEASE/ UNPLUG/DESOLDER	Note
[7]	Loader Holder	D3	2(S-6)	-
[8]	DVD Main CBA	D4	(S-7), *CN201, *CN301	2 2-1 2-2 3
[9]	VCR Chassis Unit	D5	5(S-8), 2(S-9), 2(S-10), (L-3)	-
[10]	Deck Assembly	D6	Desolder, 2(S-11), (S-12)	4,5
[11]	DVD Open/Close CBA	D6	Desolder	-
[12]	Power SW CBA	D6	Desolder	-
[13]	Main CBA	D6	-----	-
[14]	Jack-A CBA	D6	Desolder, 2(S-13)	-

- (1) ↓
- (2) ↓
- (3) ↓
- (4) ↓
- (5) ↓

4-1-2 Disassembly Method

ID/LOC. No.	PART	REMOVAL		
		Fig. No.	REMOVE/*UNHOOK/ UNLOCK/RELEASE/ UNPLUG/DESOLDER	Note
[1]	Top Case	D1	8(S-1)	-
[2]	Front Assembly	D2	*3(L-1), *3(L-2)	1 1-1 1-2
[3]	Top Bracket	D2	3(S-2)	-
[4]	DVD Mecha Assembly	D3	4(S-3), *CN401, *CN601	-
[5]	Partition Plate	D3	(S-4)	-
[6]	Power Supply CBA	D3	2(S-5), CN501	-

Note:

- (1): Identification (location) No. of parts in the figures
- (2): Name of the part
- (3): Figure Number for reference
- (4): Identification of parts to be removed, unhooked, unlocked, released, unplugged, unclamped, or desoldered.
P=Spring, L=Locking Tab, S=Screw, CN=Connector
*=Unhook, Unlock, Release, Unplug, or Desolder
e.g. 2(S-2) = two Screws (S-2),
2(L-2) = two Locking Tabs (L-2)
- (5): Refer to "Reference Notes."

Reference Notes

CAUTION 1: Locking Tabs (L-1) and (L-2) are fragile. Be careful not to break them.

1-1. Release three Locking Tabs (L-1).

1-2. Release three Locking Tabs (L-2), then remove the Front Assembly.

CAUTION 2: Electrostatic breakdown of the laser diode in the optical system block may occur as a potential difference caused by electrostatic charge accumulated on cloth, human body etc, during unpacking or repair work.

To avoid damage of pickup follow next procedures.

2-1. Disconnect Connector (CN301). Remove a Screw (S-7) and lift the DVD Main CBA Unit. (Fig. D4)

2-2. Short the three short lands of FPC cable with solder before removing the FFC cable (CN201) from it. If you disconnect the FFC cable (CN201), the laser diode of pickup will be destroyed. (Fig. D4)

CAUTION 3: When reassembling, confirm the FFC cable (CN201) is connected completely. Then remove the solder from the three short lands of FPC cable. (Fig. D4)

4. When reassembling, solder wire jumpers as shown in Fig. D6.

5. Before installing the Deck Assembly, be sure to place the pin of LD-SW on Main CBA as shown in Fig. D6. Then, install the Deck Assembly while aligning the hole of Cam Gear with the pin of LD-SW, the shaft of Cam Gear with the hole of LD-SW as shown in Fig. D6.

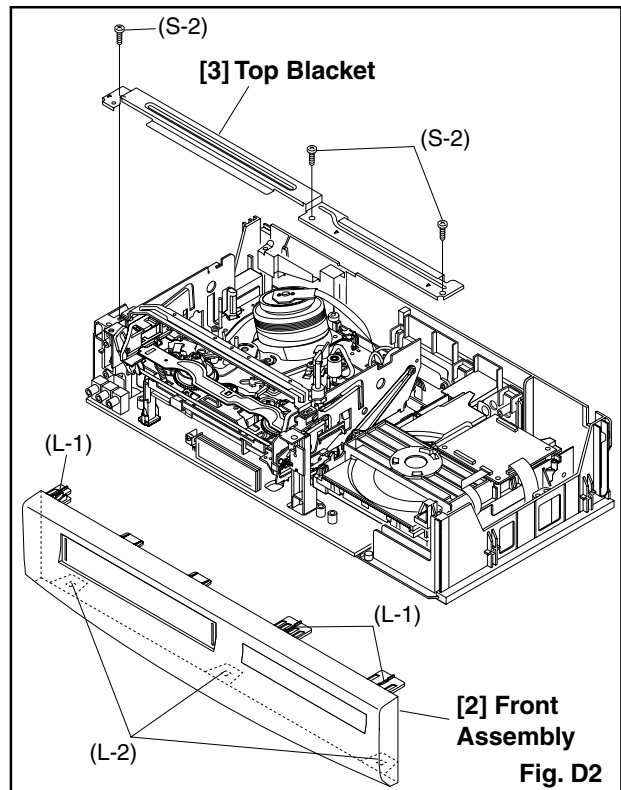
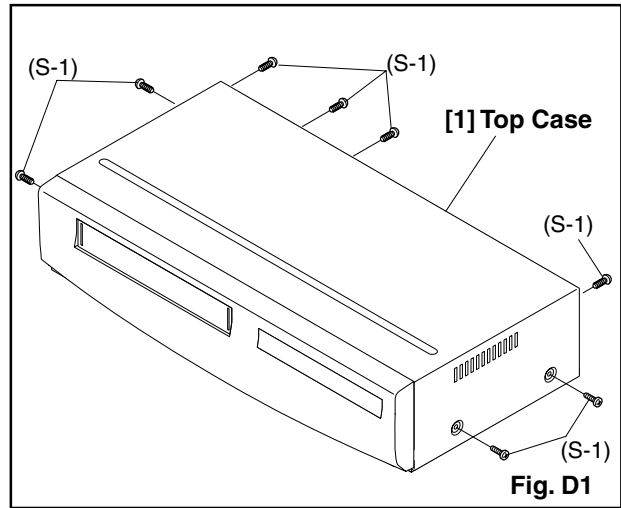

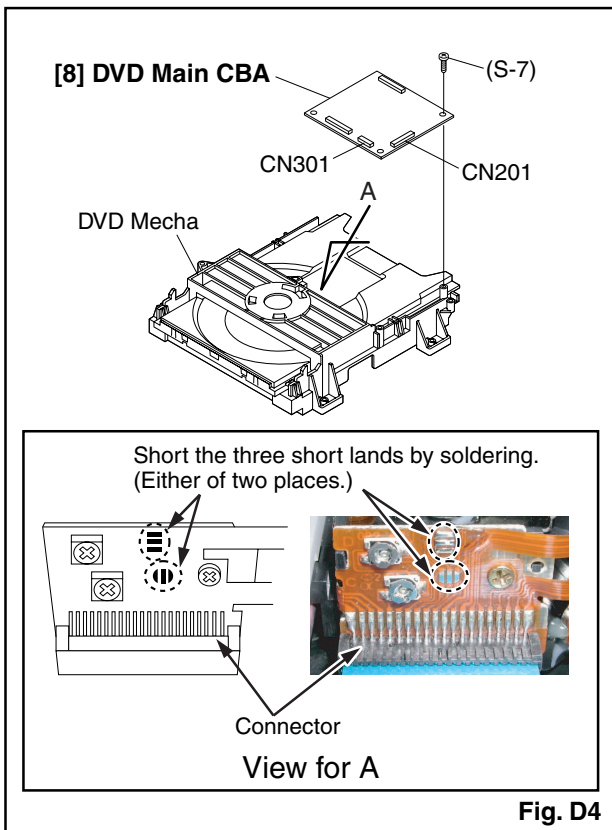
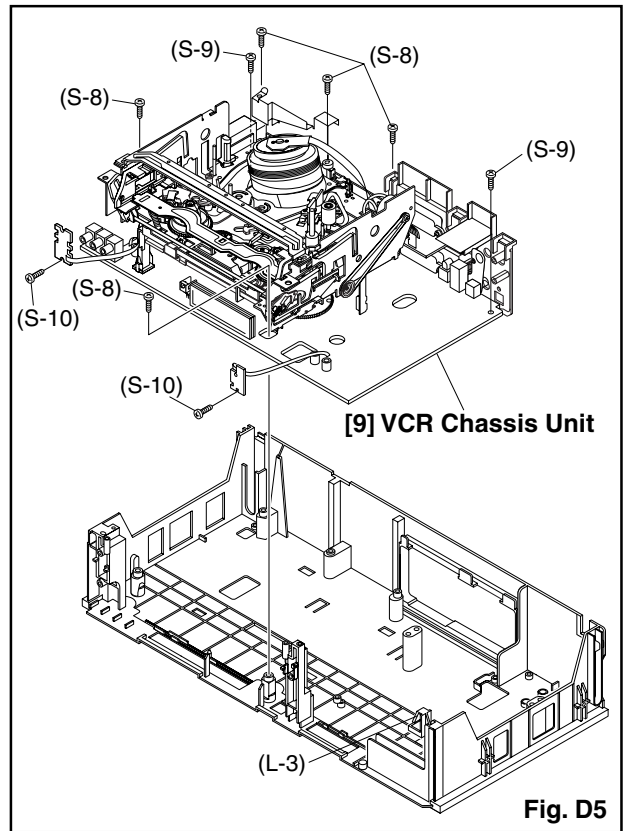
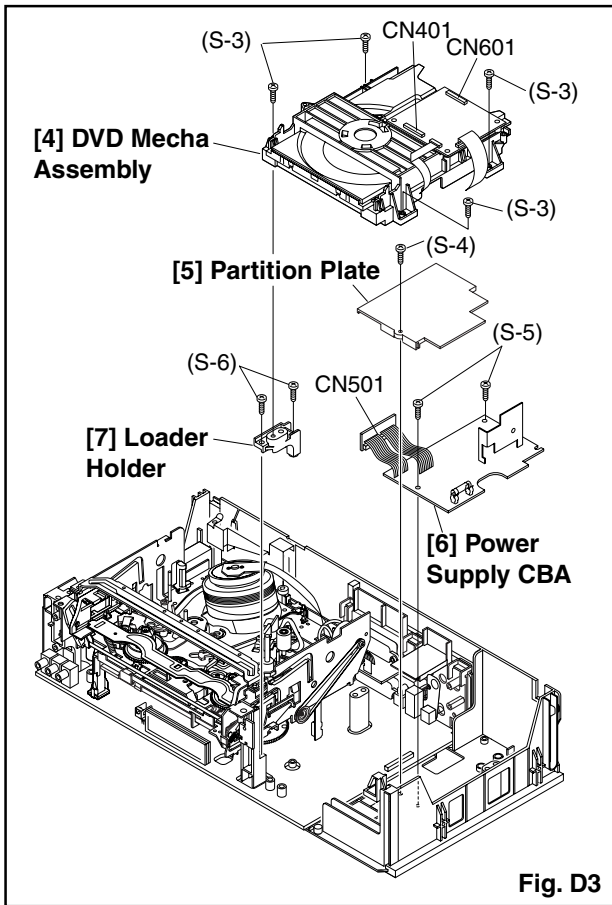

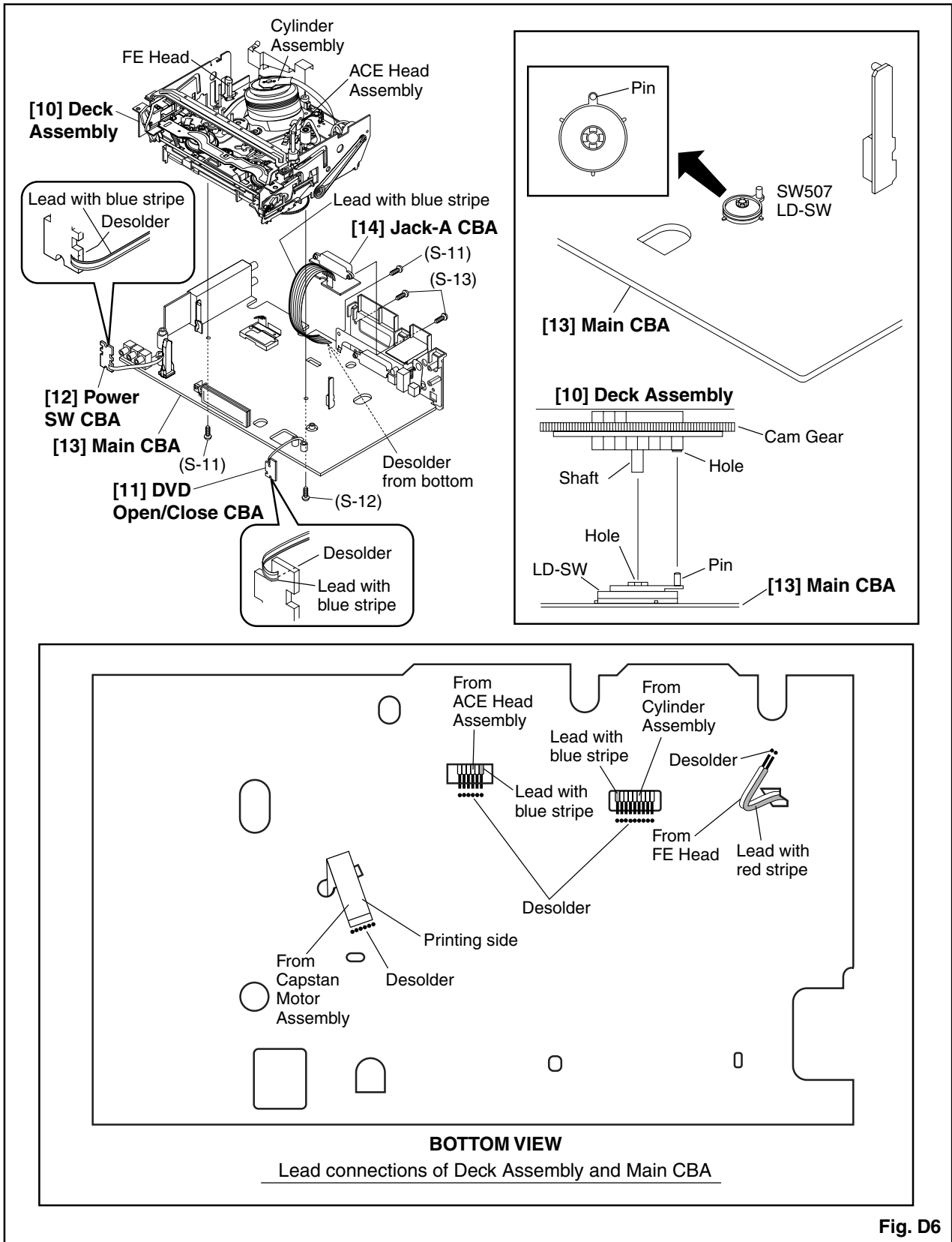
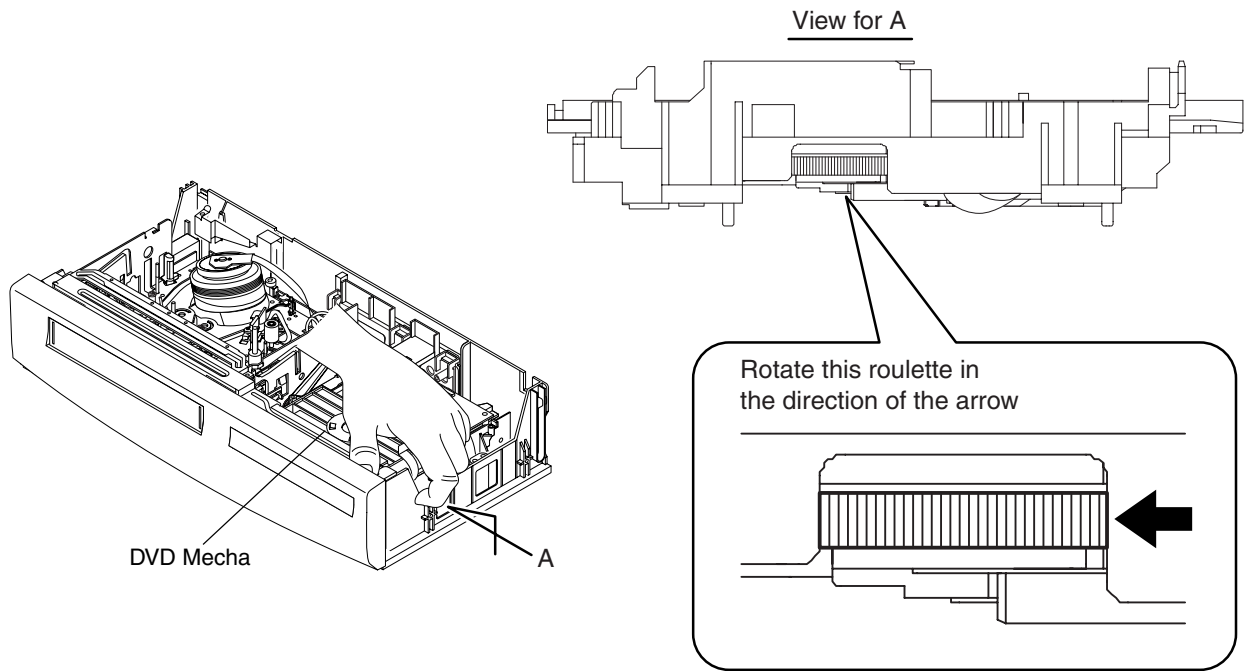

Fig. D6

HOW TO EJECT MANUALLY

1. Remove the Top Case.
2. Rotate the roulette in the direction of the arrow as shown below.
3. Pull the tray slowly with a hand.



4-2 DISASSEMBLY/ASSEMBLY PROCEDURES OF DECK MECHANISM

Before following the procedures described below, be sure to remove the deck assembly from the cabinet. (Refer to CABINET DISASSEMBLY INSTRUCTIONS on page 4-1.)

All the following procedures, including those for adjustment and replacement of parts, should be done in Eject mode; see the positions of [44] and [45] in Fig. DM1H on page 4-8. When reassembling, follow the steps in reverse order.

STEP /LOC. No.	START-ING No.	PART		REMOVAL		INSTALLATION
				Fig. No.	REMOVE/*UNHOOK/ UNLOCK/RELEASE/ UNPLUG/DESOLDER	ADJUSTMENT CONDITION
[1]	[1]	Guide Holder A	T	DM3H	2(S-1)	
[2]	[1]	Cassette Holder Assembly	T	DM4H		
[3]	[2]	Slider (SP)	T	DM5H	(S-1A), *(L-1)	
[4]	[2]	Slider (TU)	T	DM5H	*(L-2)	
[5]	[4]	Lock Lever	T	DM5H	*(L-3), *(P-1)	
[6]	[2]	Cassette Plate	T	DM5H		
[7]	[7]	Cylinder Assembly	T	DM1H, DM6H	Desolder, 3(S-2)	
[8]	[8]	Loading Motor Assembly	T	DM1H, DM7H	Desolder, LDG Belt, 2(S-3)	
[9]	[9]	ACE Head Assembly	T	DM1H, DM7H	(S-4)	
[10]	[2]	Tape Guide Arm Assembly	T	DM1H, DM8H-1	*(P-2)	
[11]	[10]	C Door Opener	T	DM1H, DM8H-1	(S-4A), *(L-4)	
[12]	[11]	Pinch Arm (B)	T	DM1H, DM8H-1, DM8H-2	*(P-3)	
[13]	[12]	Pinch Arm (A) Assembly	T	DM1H, DM8H-1, DM8H-2		
[14]	[14]	FE Head	T	DM1H, DM9H	(S-5)	
[15]	[15]	Prism	T	DM1H, DM9H	(S-6)	
[16]	[2]	Slider Shaft	T	DM10H	*(L-5)	
[17]	[16]	C Drive Lever (SP)	T	DM10H		
[18]	[16]	C Drive Lever (TU)	T	DM10H	(S-7), *(P-4)	
[19]	[19]	Capstan Motor	B	DM2H, DM11H	3(S-8), Cap Belt	
[20]	[20]	Clutch Assembly (HI)	B	DM2H, DM12H	(C-1)	
[21]	[20]	Center Gear	B	DM12H		
[22]	[22]	F Brake Assembly (HI)	B	DM2H, DM12H	*(L-6)	
[23]	[22]	Worm Holder	B	DM2H, DM13H-1	(S-9), *(L-7), *(L-8)	
[24]	[22]	Pulley Assembly (HI)	B	DM2H, DM13H-1		
[25]	[25]	Mode Gear (LM)	B	DM2H, DM13H-1	(C-2)	
[26]	[20],[25]	Mode Lever (HI)	B	DM2H, DM13H-1, DM13H-2	(C-3)	
[27]	[22],[23], [26]	Cam Gear (A) (HI)	B	DM2H, DM13H-1, DM13H-2	(C-4)	(+)Refer to Alignment Sec. Page 4-15
[28]	[26]	TR Gear C	B	DM2H, DM13H-1	(C-5)	
[29]	[28]	TR Gear Spring	B	DM13H-1		
[30]	[29]	TR Gear A/B	B	DM13H-1		
[31]	[31]	FF Arm (HI)	B	DM1H, DM14H		
[32]	[26]	Idler Assembly (HI)	B	DM1H, DM14H	*(L-9)	

STEP /LOC. No.	START-ING No.	PART		REMOVAL		INSTALLATION
				Fig. No.	REMOVE/*UNHOOK/ UNLOCK/RELEASE/ UNPLUG/DESOLDER	ADJUSTMENT CONDITION
[33]	[26]	BT Arm	B	DM2H, DM14H	*(P-5)	
[34]	[26]	Loading Arm (SP) Assembly	B	DM2H, DM14H		(+)Refer to Alignment Sec. Page 4-15
[35]	[34]	Loading Arm (TU) Assembly	B	DM2H, DM14H		(+)Refer to Alignment Sec. Page 4-15
[36]	[16],[26]	M Brake (TU) Assembly (HI)	T	DM1H, DM15H		
[37]	[2],[26]	M Brake (SP) Assembly (HI)	T	DM1H, DM15H	*(P-6)	
[38]	[37]	Tension Lever Assembly	T	DM1H, DM15H		
[39]	[38]	T Lever Holder	T	DM15H	*(L-10)	
[40]	[40]	M Gear (HI)	T	DM1H, DM15H	(C-6)	
[41]	[15],[40]	Sensor Gear (HI)	T	DM1H, DM15H	(C-7)	
[42]	[36],[40]	Reel T	T	DM1H, DM15H		
[43]	[38]	Reel S	T	DM1H, DM15H		
[44]	[34],[38]	Moving Guide S Preparation	T	DM1H, DM16H	(S-11), Slide Plate	
[45]	[35]	Moving Guide T Preparation	T	DM1H, DM16H		
[46]	[19]	TG Post Assembly	T	DM1H, DM16H	*(L-11)	
[47]	[27]	Rack Assembly	R	DM17H		(+)Refer to Alignment Sec. Page 4-15
[48]	[47]	F Door Opener	R	DM17H		
[49]	[49]	Cleaner Assembly	T	DM1H, DM6H		
[50]	[49]	CL Post	T	DM6H	*(L-12)	

(1)

(2)

(3)

(4)

(5)

(6)

(7)

(1): Follow steps in sequence. When reassembling, follow the steps in reverse order.

These numbers are also used as identification (location) No. of parts in the figures.

(2): Indicates the part to start disassembling with in order to disassemble the part in column (1).

(3): Name of the part

(4): Location of the part: T=Top B=Bottom R=Right L=Left

(5): Figure Number

(6): Identification of parts to be removed, unhooked, unlocked, released, unplugged, unclamped, or desoldered.

P=Spring, W=Washer, C=Cut Washer, S=Screw, *=Unhook, Unlock, Release, Unplug, or Desolder

e.g., 2(L-2) = two Locking Tabs (L-2).

(7): Adjustment Information for Installation

(+):Refer to Deck Exploded Views for lubrication.

Top View

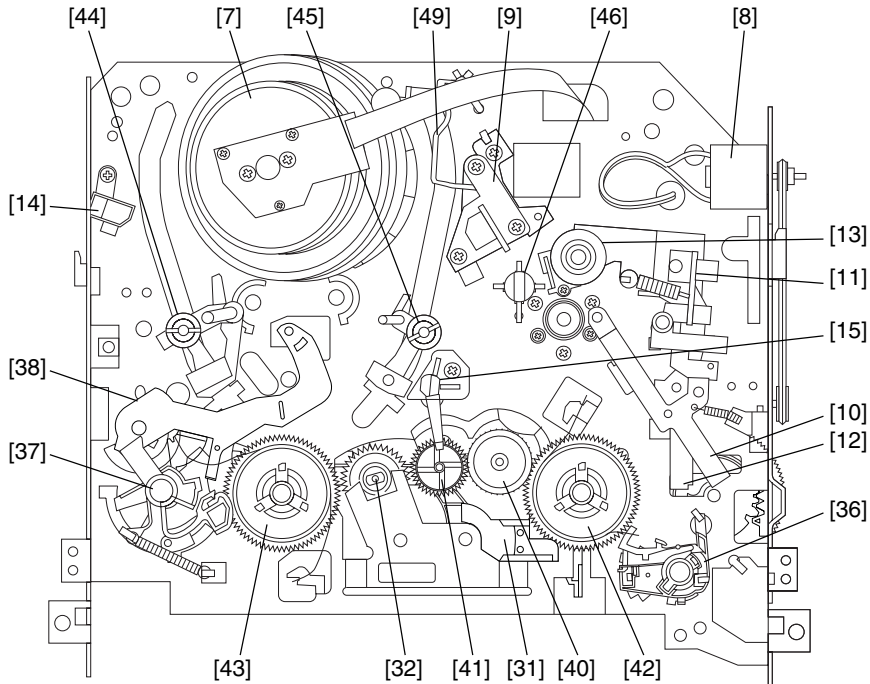

Fig. DM1H

Bottom View

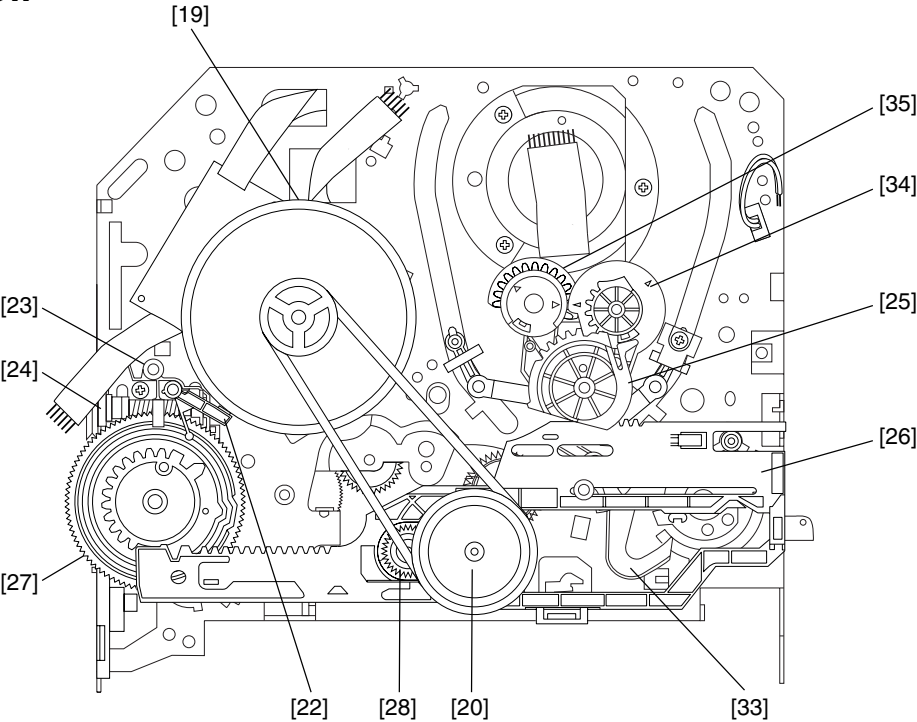

Fig. DM2H

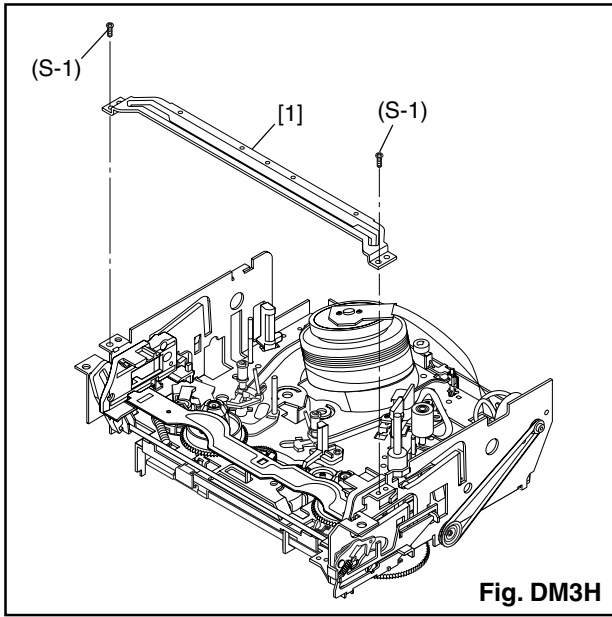
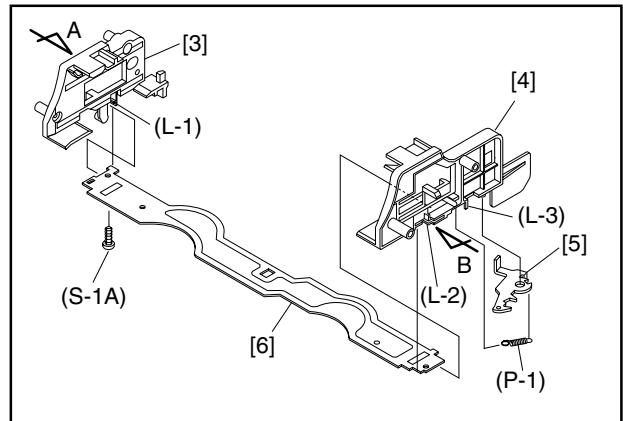
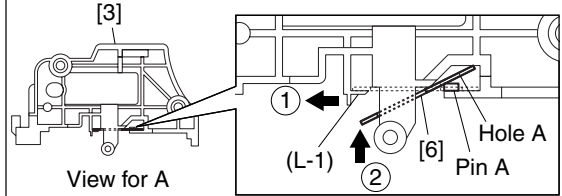

Fig. DM3H



Installation of [3] and [6]

First, insert [6] diagonally in [3] as shown below. Then, install [6] in [3] while pushing (L-1) in a direction of arrow. After installing [6] in [3], confirm that pin A of [3] enters hole A of [6] properly.



Installation of [4] and [6]

Install [6] in [4] while pulling (L-2) in a direction of arrow. After installing [6] in [4], confirm that pin B of [4] enters hole B of [6] properly.

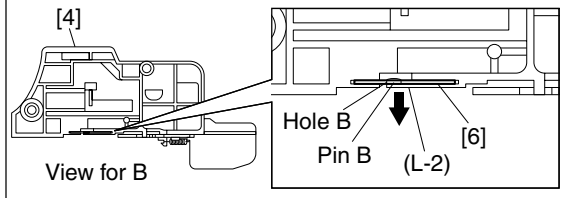
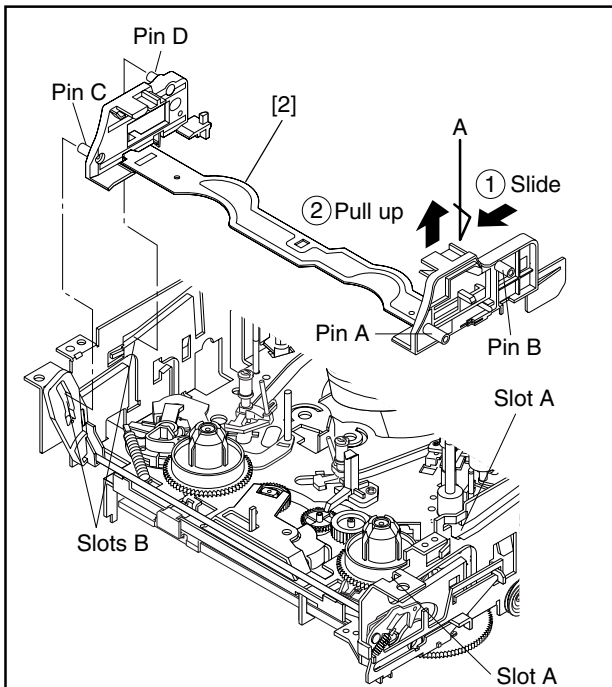

Fig. DM5H



First, while pushing the locking tab as shown in the right, slide and pull up the right side on [2] to release Pin A and Pin B from the slots A.
Then, remove Pin C and Pin D on [2] from the slots B as shown.

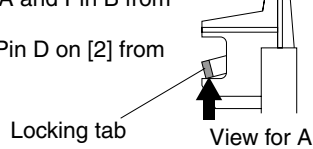
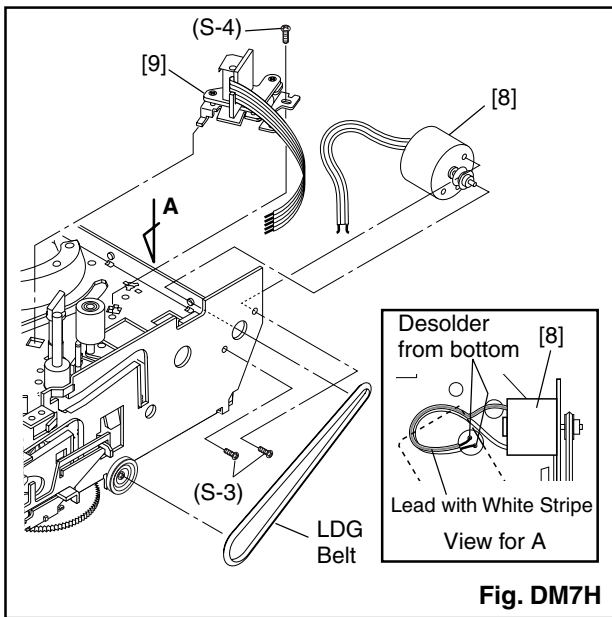
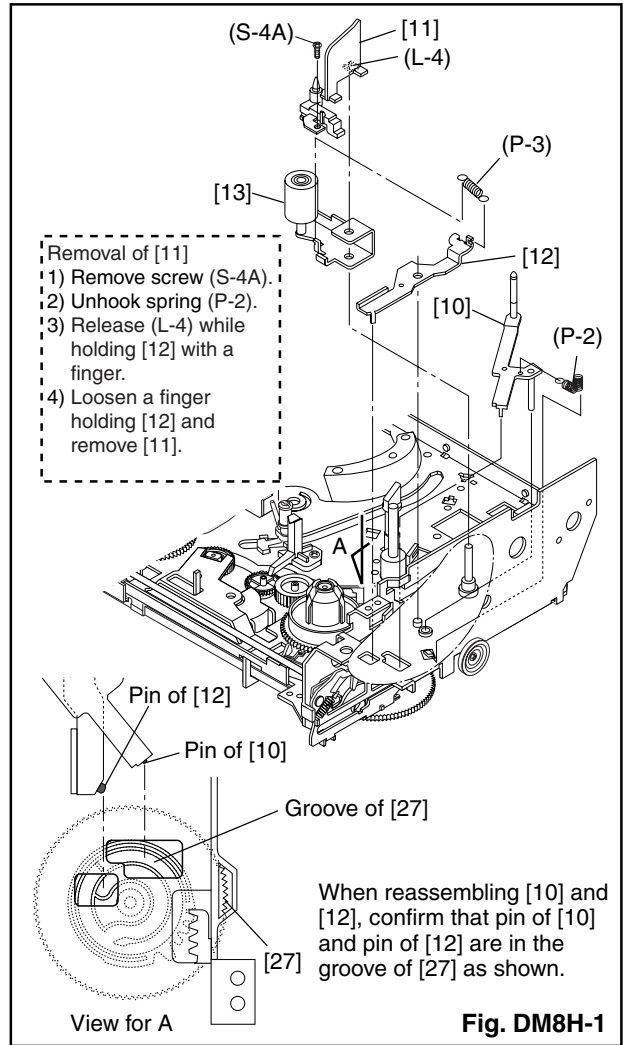
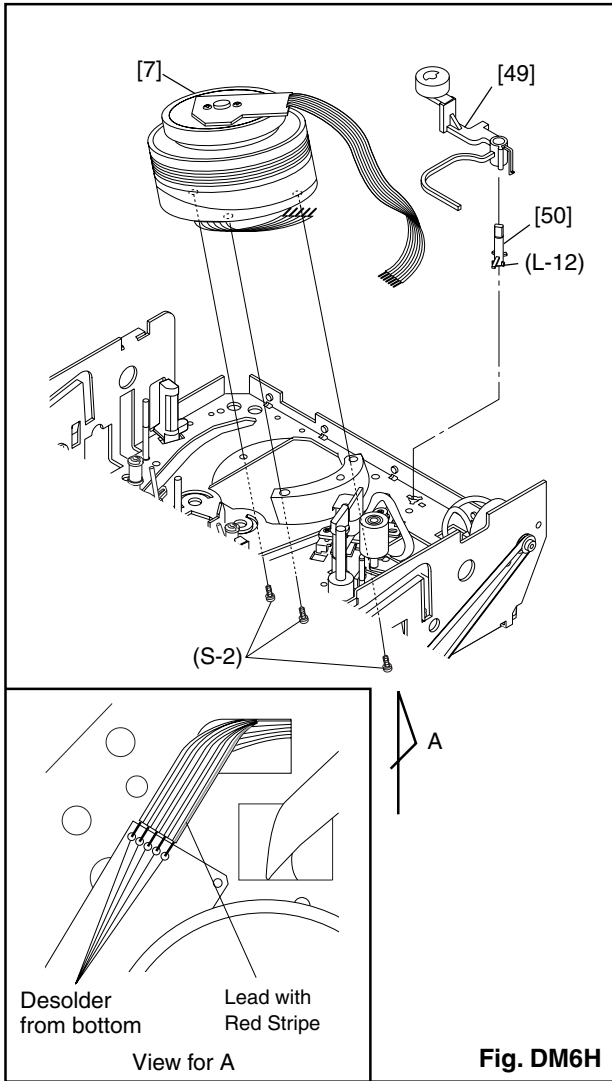

Fig. DM4H



Installation of [13] and [12]

Hook spring (P-3) up to [12] and [13], then install them to the specified position so that [12] will be floated slightly while holding [12] and [13]. (Refer to Fig. A.)

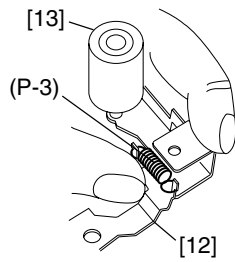

Fig. A

Install pin of [12] in groove of [27]. (Refer to Fig. B.)

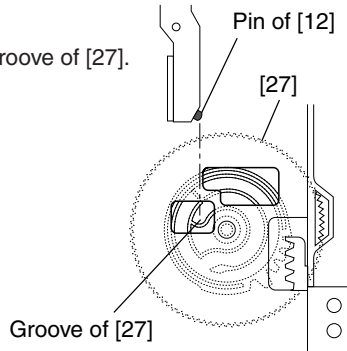

Fig. B (Top view)

Hold [12] and [13] till groove of pin of chassis looks and fit [13] in notch of chassis. Then, turn a few [13] while holding [12]. (Refer to Fig. C.)

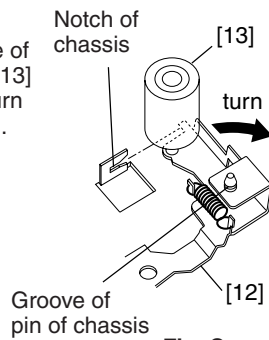

Fig. C

Install [11] and [10] while holding [12]. (Refer to Fig. DM8H-1.)

Fig. DM8H-2

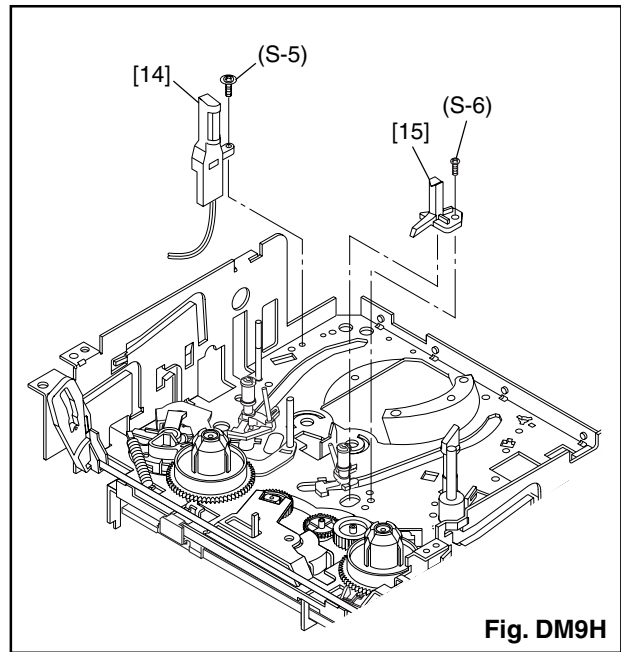

Fig. DM9H

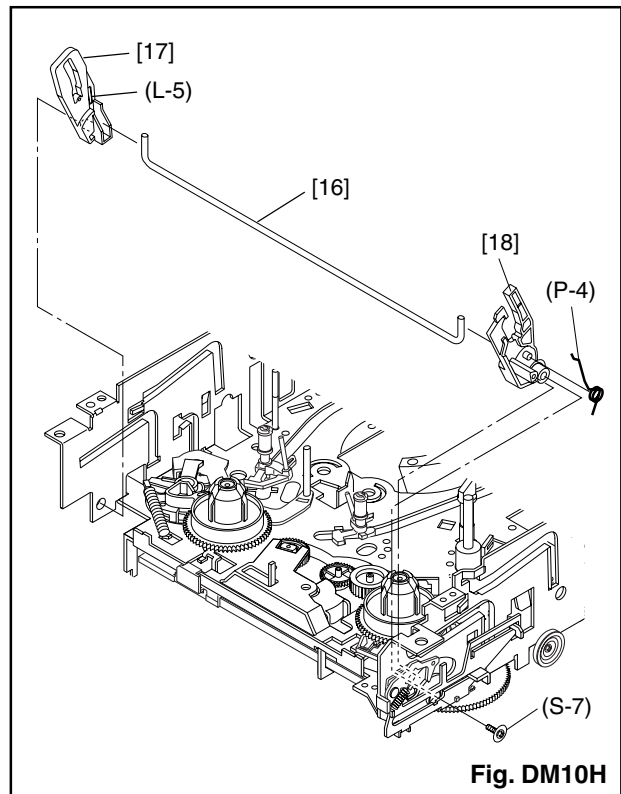
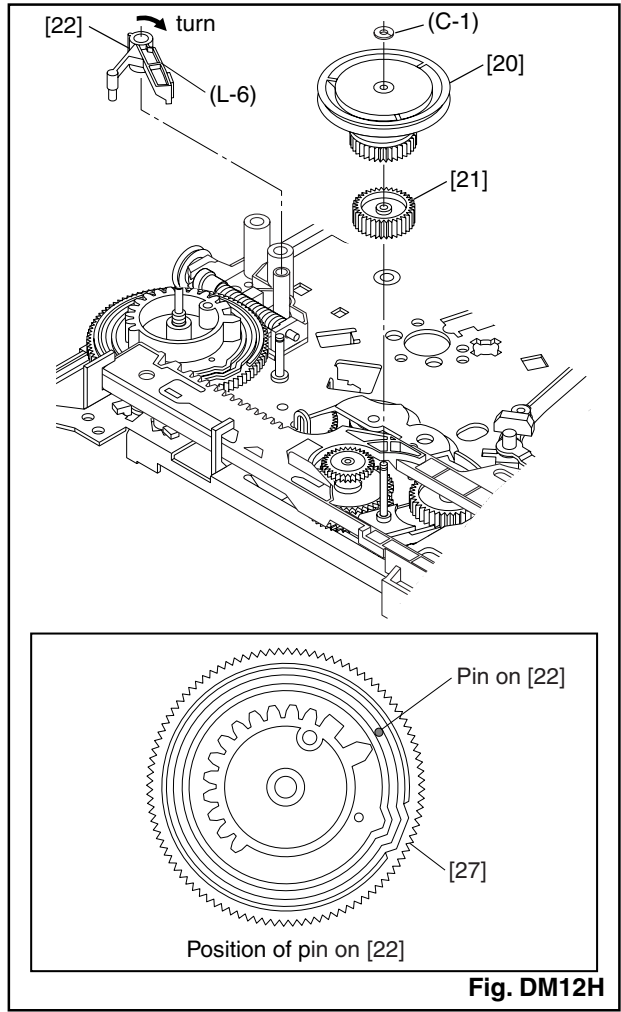
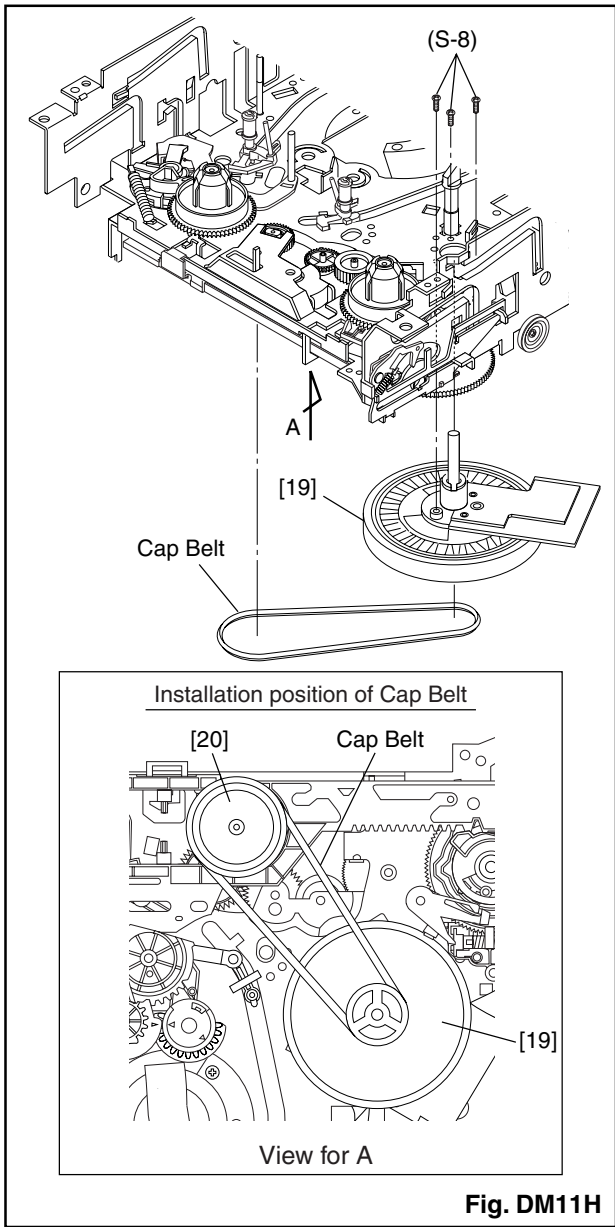

Fig. DM10H



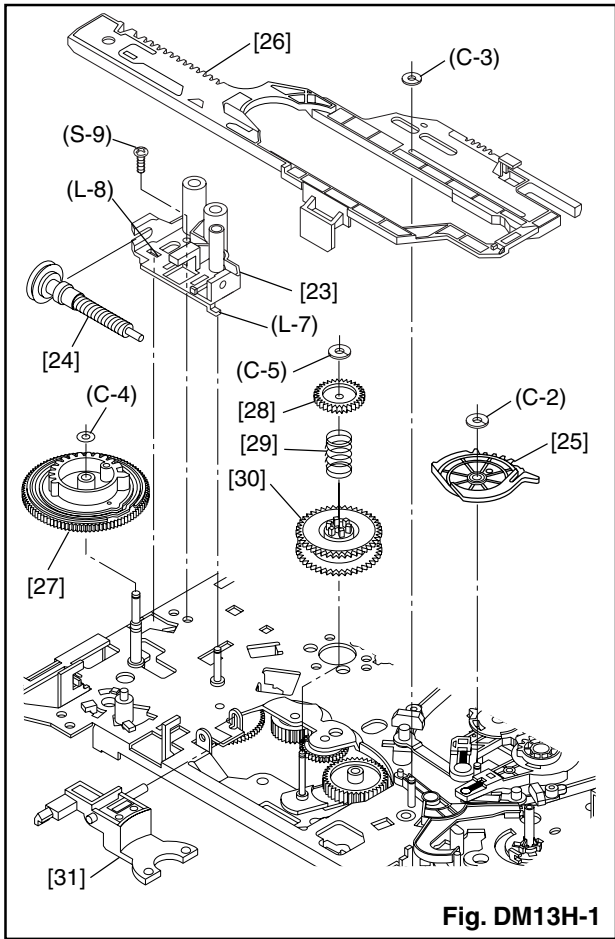

Fig. DM13H-1

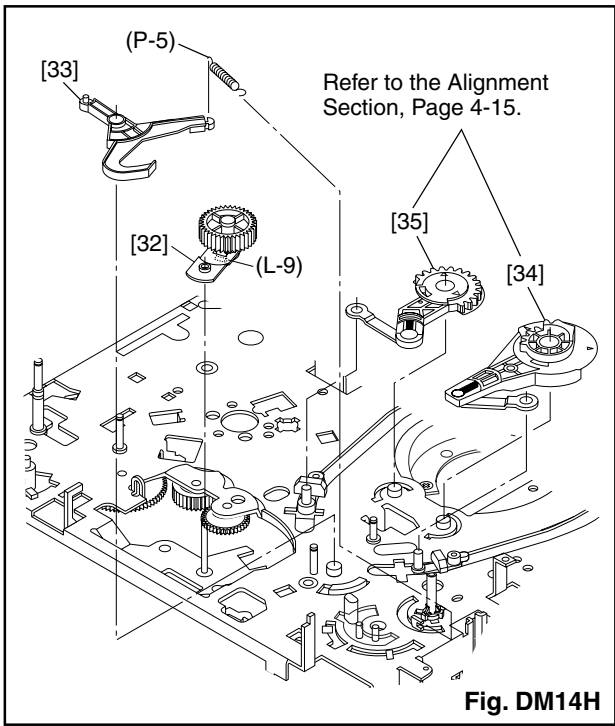

Fig. DM14H

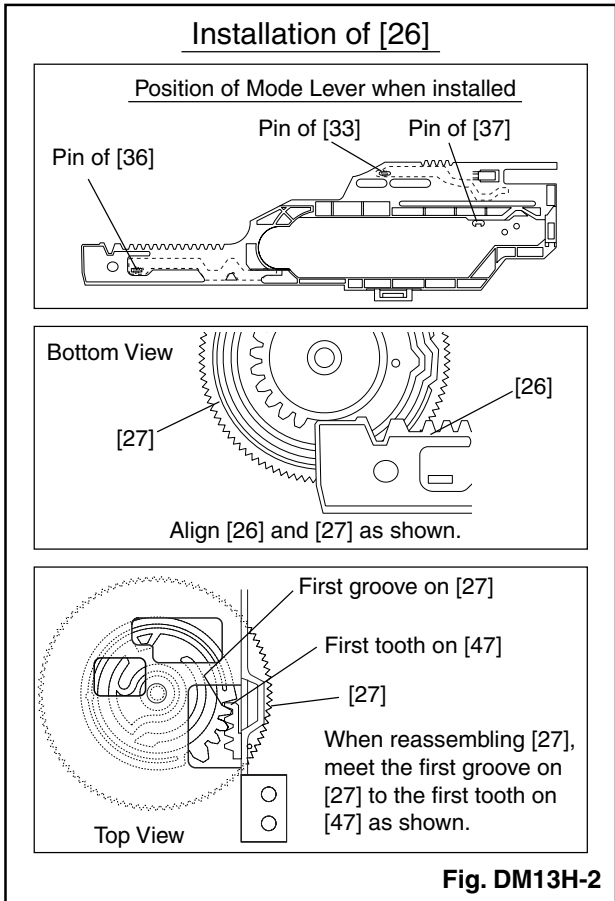

Fig. DM13H-2

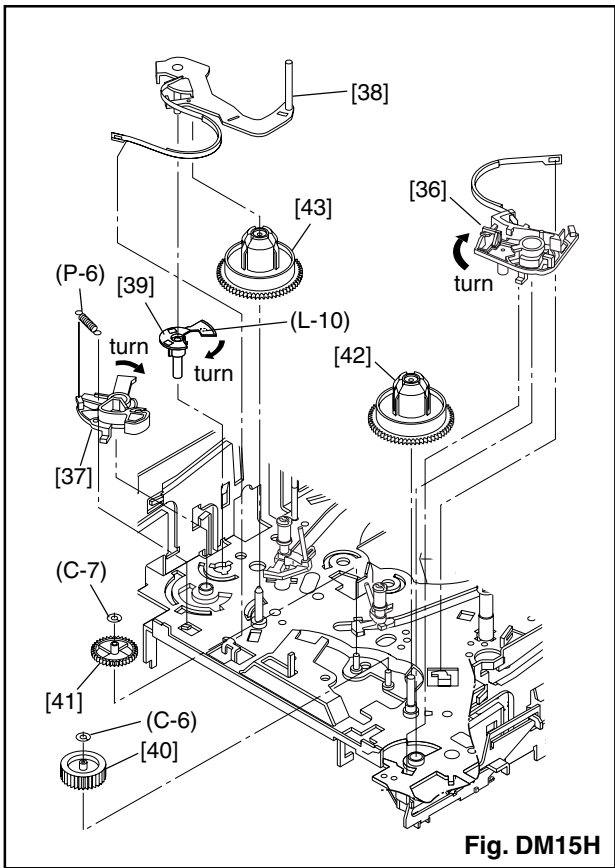
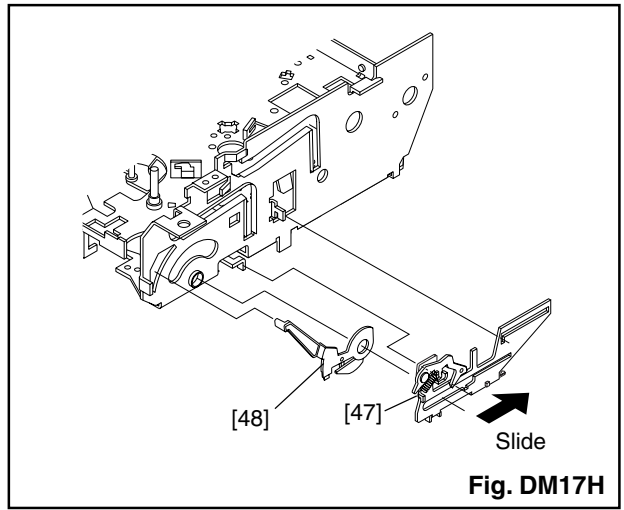
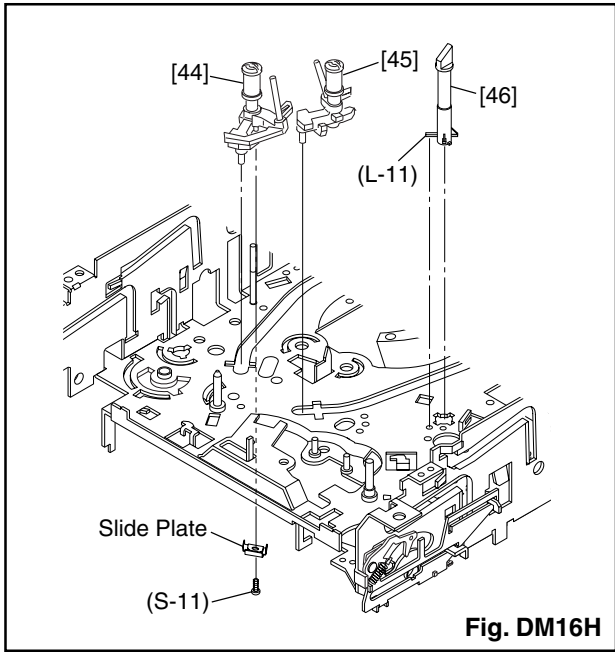

Fig. DM15H



4-3 ALIGNMENT PROCEDURES OF MECHANISM

The following procedures describe how to align the individual gears and levers that make up the tape loading/unloading mechanism. Since information about the state of the mechanism is provided to the System Control Circuit only through the Mode Switch, it is essential that the correct relationship between individual gears and levers be maintained.

All alignments are to be performed with the mechanism in Eject mode, in the sequence given. Each procedure assumes that all previous procedures have been completed.

IMPORTANT:

If any one of these alignments is not performed properly, even if off by only one tooth, the unit will unload or stop and it may result in damage to the mechanical or electrical parts.

Alignment points in Eject Position

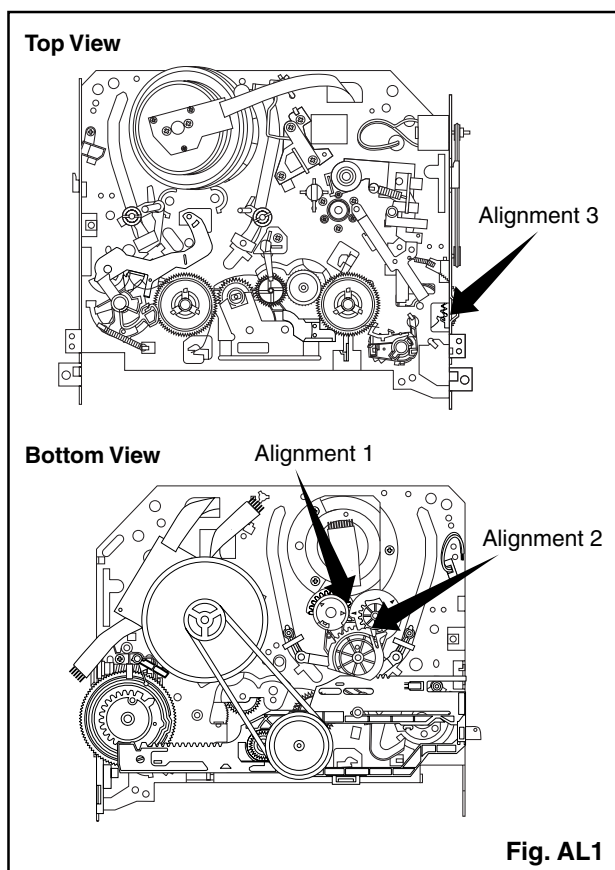

Alignment 1

Loading Arm (SP) and (TU) Assembly

Install Loading Arm (SP) and (TU) Assembly so that their triangle marks point to each other as shown in Fig. AL2.

Alignment 2

Mode Gear

Keeping the two triangles pointing at each other, install the Loading Arm (SP) Assembly so that the last tooth of the gear meets the most inside teeth of the Mode Gear. See Fig. AL2.

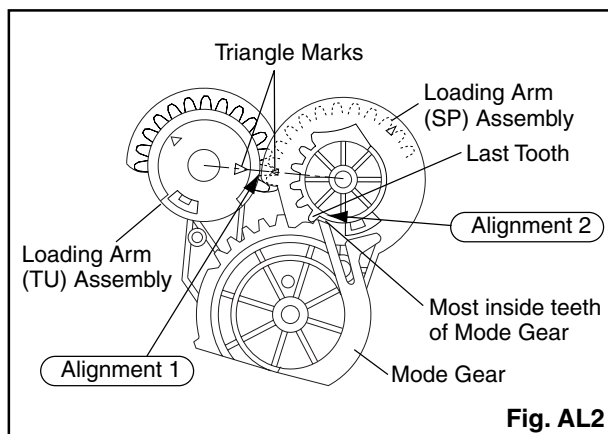

Alignment 3

Cam Gear (A) (HI), Rack Assembly

Install the Rack Assembly so that the first tooth on the gear of the Rack Assembly meets the first groove on the Cam Gear (A) (HI) as shown in Fig. AL3.

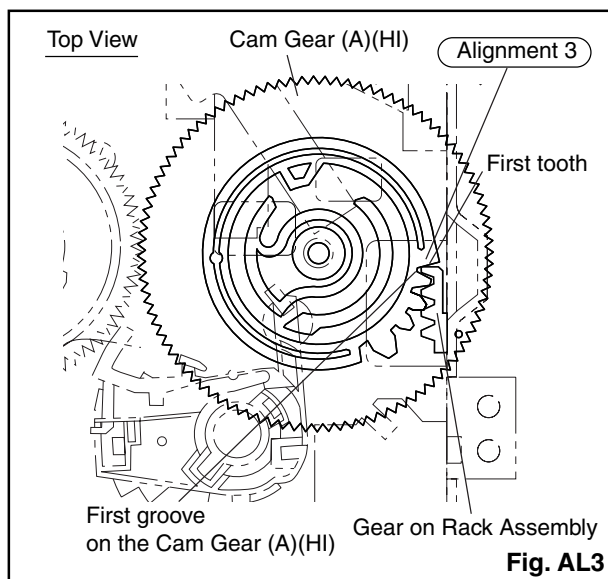

5-1 PREPARATION FOR SERVICING

5-1-1 How to Enter the Service Mode

About Optical Sensors

Caution:

An optical sensor system is used for the Tape Start and End Sensors on this equipment. Carefully read and follow the instructions below. Otherwise the unit may operate erratically.

What to do for preparation

Insert a tape into the Deck Mechanism Assembly and press the PLAY button. The tape will be loaded into the Deck Mechanism Assembly. Make sure the power is on, connect TP501 (S-INH) to GND. This will stop the function of Tape Start Sensor, Tape End Sensor and Reel Sensors. (If these TPs are connected before plugging in the unit, the function of the sensors will stay valid.) See Fig. 5-1-1.

Note: Because the Tape End Sensors are inactive, do not run a tape all the way to the start or the end of the tape to avoid tape damage.

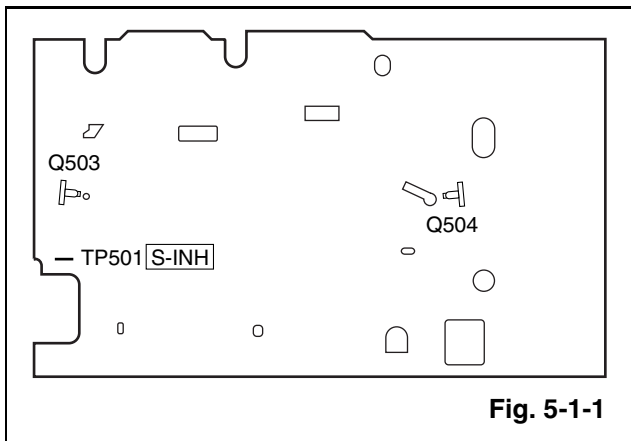

5-2 FIXTURE AND TAPE FOR ADJUSTMENT

1. Alignment Tape (MH-2)
No. 7099052

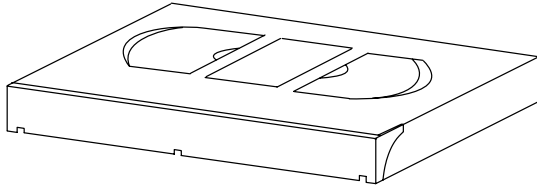

3. Flat Screwdriver
(Purchase Locally)

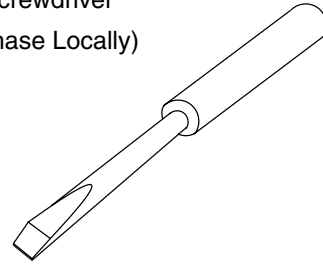

2. Guide Roller Adj. Screwdriver
No. 7099028

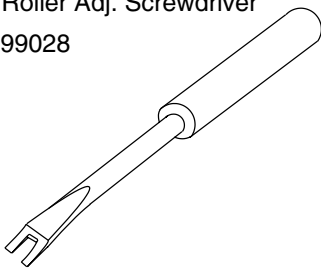

5-2-1 How To Use The Fixtures And Tape

Item No.	Name	Part No.	Adjustment
1	Alignment Tape (MH-2)	7099052	<ul style="list-style-type: none"> ● Head Switching Position ● Tape Interchangeability Alignment
2	Guide Roller Adj. Screwdriver	7099028	<ul style="list-style-type: none"> ● Guide Roller
3	Flat Screwdriver	Purchase Locally	<ul style="list-style-type: none"> ● X Value Alignment

5-3 ELECTRICAL ADJUSTMENT INSTRUCTIONS

General Note: "CBA" is an abbreviation for "Circuit Board Assembly."

NOTE:

1. Electrical adjustments are required after replacing circuit components and certain mechanical parts. It is important to do these adjustments only after all repairs and replacements have been completed. Also, do not attempt these adjustments unless the proper equipment is available.
2. To perform these alignment / confirmation procedures, make sure that the tracking control is set in the center position: Press either "CHANNEL ▼" or "CHANNEL ▲" button on the front panel first, then the "PLAY" button on the front panel.

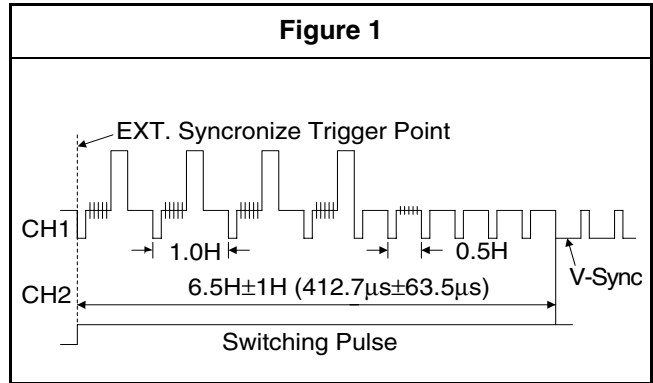

5-3-1 Test Equipment Required

1. Oscilloscope: Dual-trace with 10:1 probe, V-Range: 0.001~50V/Div., F-Range: DC~AC-20MHz
2. Alignment Tape (MH-2)

Reference Notes:

Playback the Alignment tape and adjust VR501 so that the V-sync front edge of the CH1 video output waveform is at the 6.5H±1H (412.7µs±63.5µs) delayed position from the rising edge of the CH2 head switching pulse waveform.

5-3-2 Head Switching Position Adjustment

Purpose:

To determine the Head Switching position during playback.

Symptom of Misadjustment:

May cause Head Switching noise or vertical jitter in the picture.

Test point	Adj. Point	Mode	Input
TP751(V-OUT) TP504(RF-SW) GND	VR501 (Switching Point) (MAIN CBA)	PLAY (SP)	----
Tape	Measurement Equipment	Spec.	
MH-2	Oscilloscope	6.5H±1H (412.7µs±63.5µs)	

Connections of Measurement Equipment

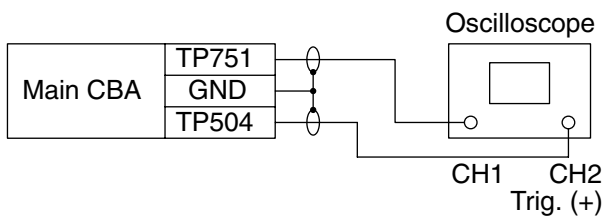

5-4 MECHANICAL ALIGNMENT PROCEDURES

Explanation of alignment for the tape to correctly run starts on the next page. Refer to the information below on this page if a tape gets stuck, for example, in the mechanism due to some electrical trouble of the unit.

5-4-1 Service Information

A. Method for Manual Tape Loading/Unloading

To load a cassette tape manually:

1. Disconnect the AC plug.
2. Remove the Top Case and Front Assembly.
3. Insert a cassette tape. Though the tape will not be automatically loaded, make sure that the cassette tape is all the way in at the inlet of the Cassette Holder. To confirm this, lightly push the cassette tape further in and see if the tape comes back out, by a spring motion, just as much as you have pushed in.
4. Turn the LDG Belt in the appropriate direction shown in Fig. 5-4-1 for a minute or two to complete this task.

To unload a cassette tape manually:

1. Disconnect the AC plug.
2. Remove the Top Case and Front Assembly.
3. Make sure that the Moving guide preparations are in the Eject Position.
4. Turn the LDG Belt in the appropriate direction shown in Fig. 5-4-1 until the Moving guide preparations come to the Eject Position. Stop turning when the preparations begin clicking or can not be moved further. However, the tape will be left wound around the cylinder.
5. Turn the LDG Belt in the appropriate direction continuously, and the cassette tape will be ejected. Allow a minute or two to complete this task.

B. Method to place the Cassette Holder in the tape-loaded position without a cassette tape

1. Disconnect the AC Plug.
2. Remove the Top Case and Front Assembly.
3. Turn the LDG Belt in the appropriate direction shown in Fig. 5-4-1. Release the locking tabs shown in Fig. 5-4-1 and continue turning the LDG Belt until the Cassette Holder comes to the tape-loaded position. Allow a minute or two to complete this task.

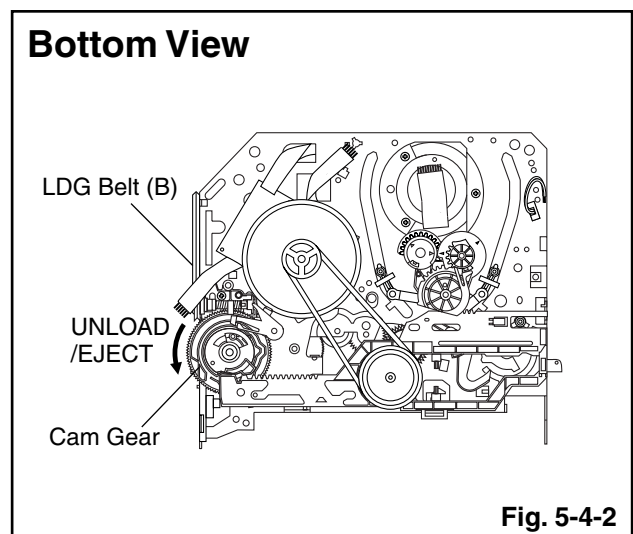
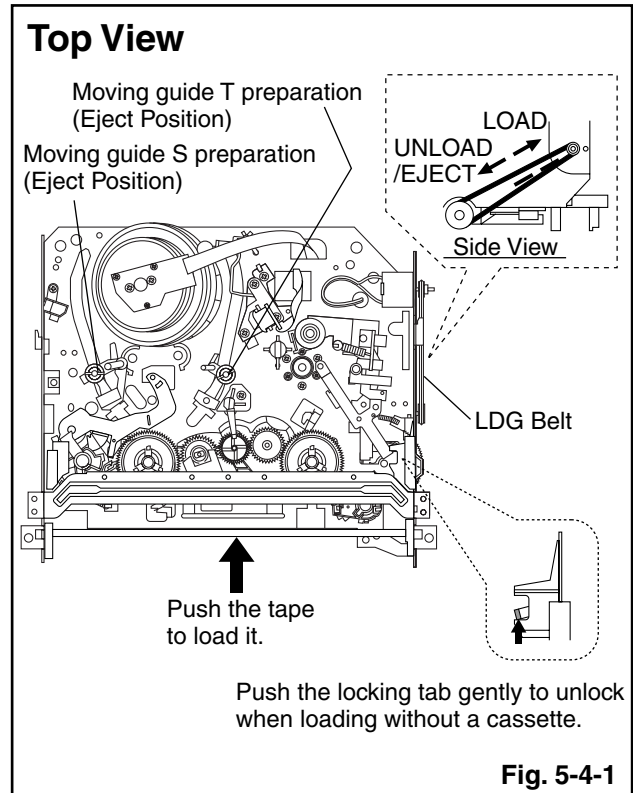

5-4-2 Tape Interchangeability Alignment

Note:

To do these alignment procedures, make sure that the Tracking Control Circuit is set to the center position every time a tape is loaded or unloaded. (Refer to page 5-7, procedure 1-C, step 2.)

Equipment required:

- Dual Trace Oscilloscope
- VHS Alignment Tape (MH-2)
- Guide Roller Adj. Screwdriver
- Flat Screwdriver (Purchase Locally)

Note: Before starting this Mechanical Alignment, do all Electrical Adjustment procedures.

Flowchart of Alignment for tape traveling

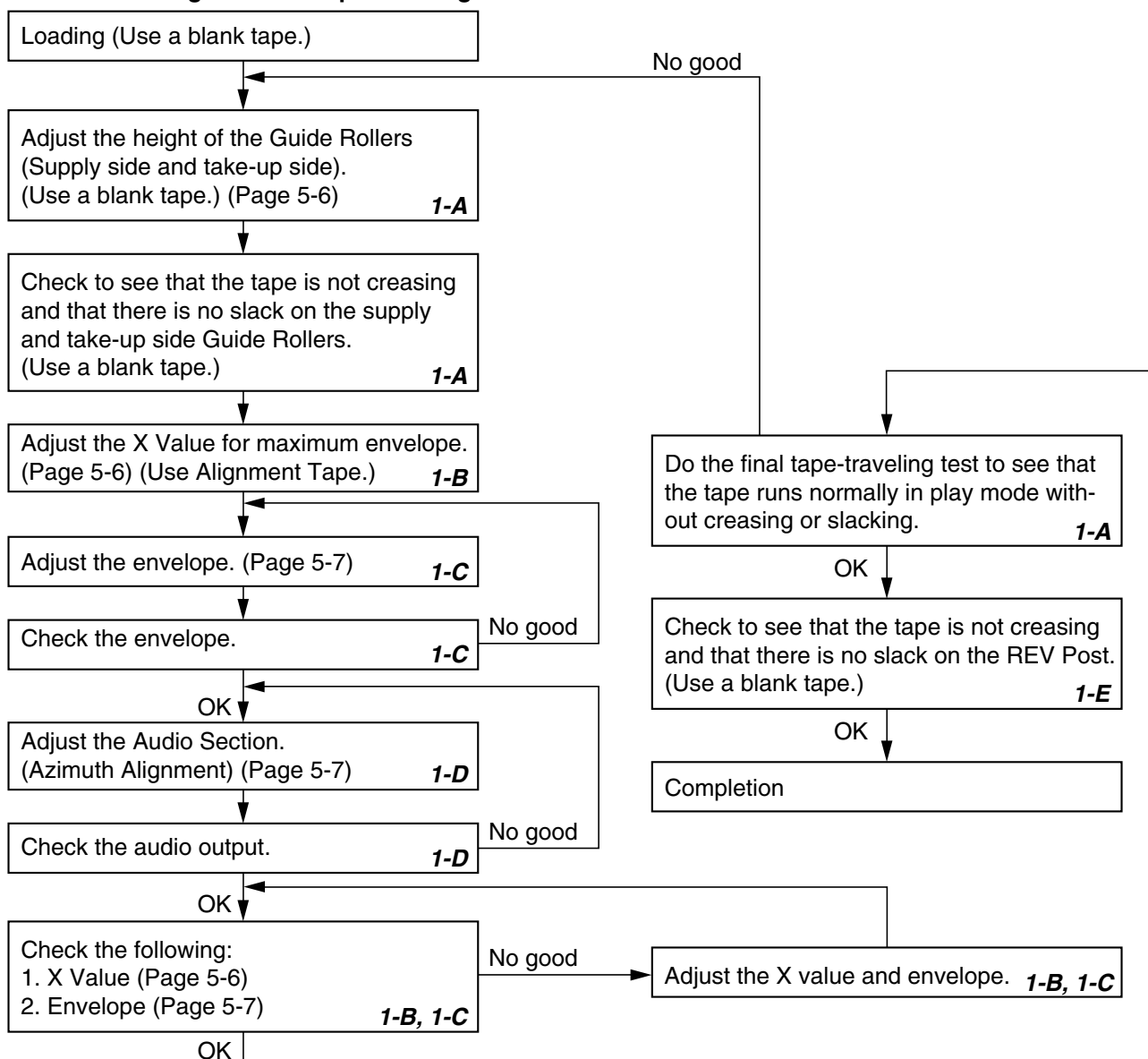

1-A. Preliminary/Final Checking and Alignment of Tape Path

Purpose:

To make sure that the tape path is well stabilized.

Symptom of Misalignment:

If the tape path is unstable, the tape will be damaged.

Note: Do not use an Alignment Tape for this procedure. If the unit is not correctly aligned, the tape may be damaged.

1. Playback a blank cassette tape and check to see that the tape runs without creasing at Guide Rollers [2] and [3], and at points A and B on the lead surface. (Refer to Fig. 5-4-3 and 5-4-4.)
2. If creasing is apparent, align the height of the guide rollers by turning the top of Guide Rollers [2] and [3] with a Guide Roller Adj. Screwdriver. (Refer to Fig. 5-4-3 and 5-4-5.)

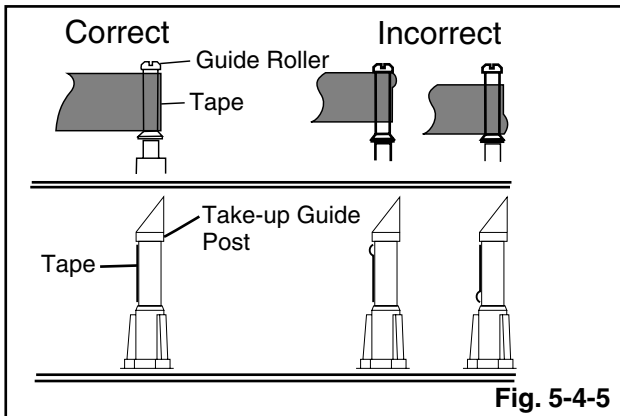
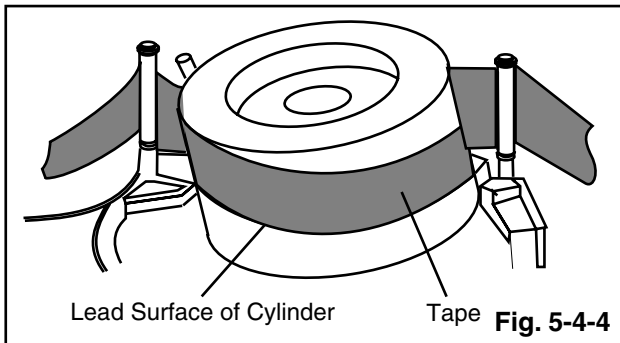
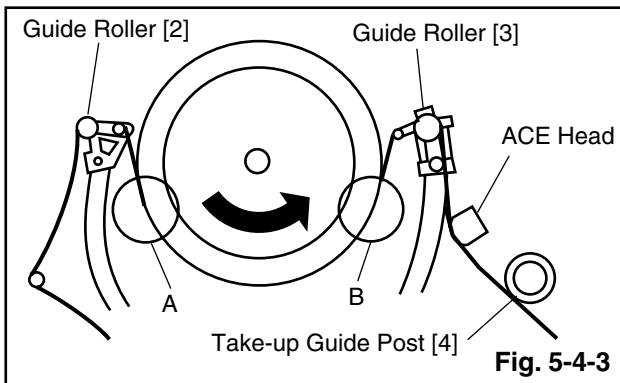

3. Check to see that the tape runs without creasing at Take-up Guide Post [4] or without snaking between Guide Roller [3] and ACE Head. (Fig. 5-4-3 and 5-4-5)

4. If creasing or snaking is apparent, adjust the Tilt Adj. Screw of the ACE Head. (Fig. 5-4-6)

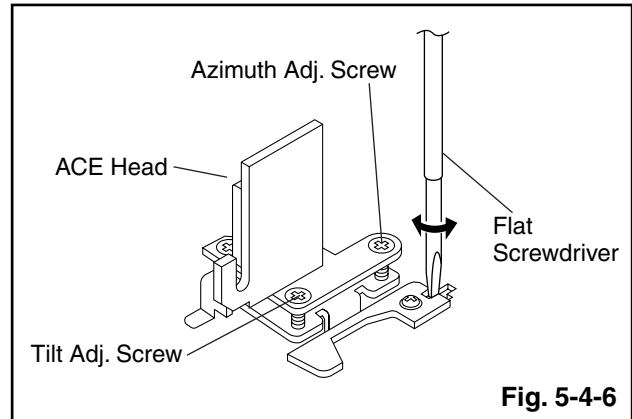

1-B. X Value Alignment

Purpose:

To obtain maximum PB FM envelope signal at the preset position of the Tracking Control Circuit, align the Horizontal Position of the ACE Head.

Symptom of Misalignment:

If the Horizontal Position of the ACE Head is not properly aligned, maximum PB FM envelope cannot be obtained at the preset position of the Tracking Control Circuit.

1. Connect the oscilloscope to TP301 (C-PB) and TP503 (CTL) on the Main CBA. Use TP504 (RF-SW) as a trigger.
2. Playback the Gray Scale of the Alignment Tape (MH-2) and confirm that the PB FM signal is present.
3. Set the Tracking Control Circuit to the preset position by pressing CH UP button on the remote control unit then "PLAY" button on the unit. (Refer to note on bottom of page 5-7.)
4. Use the Flat Screwdriver so that the PB FM signal at TP301 (C-PB) is maximum. (Fig. 5-4-6)

- To shift the CTL waveform, press CH UP or CH DOWN button on the remote control unit. Then make sure that the maximum output position of PB FM envelope signal become within $\pm 2\text{ms}$ from pre-set position.

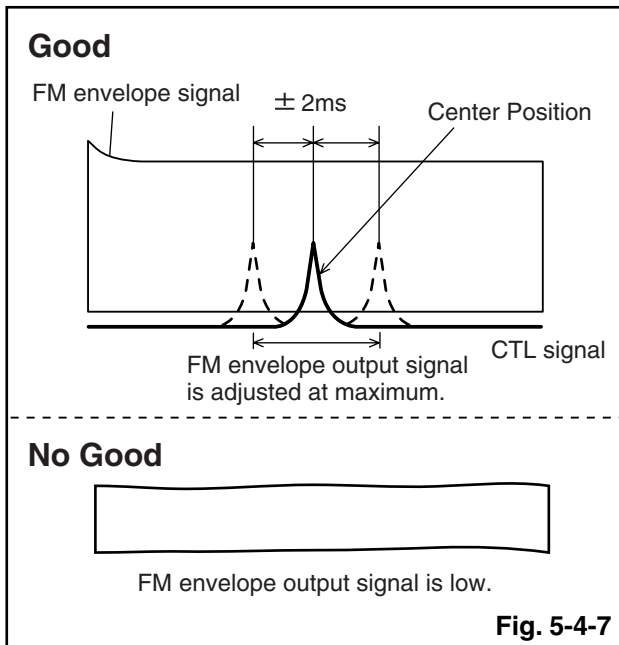

- Set the Tracking Control Circuit to the preset position by pressing CH UP button on the remote control unit. and then "PLAY" button.

1-C. Checking/Adjustment of Envelope Waveform

Purpose:

To achieve a satisfactory picture, adjust the PB FM envelope becomes as flat as possible.

Symptom of Misalignment:

If the envelope output is poor, noise will appear in the picture. The tracking will then lose precision and the playback picture will be distorted by any slight variation of the Tracking Control Circuit.

- Connect the oscilloscope to TP301 (C-PB) on the Main CBA. Use TP504 (RF-SW) as a trigger.
- Playback the Gray Scale on the Alignment Tape (MH-2). Set the Tracking Control Circuit to the preset position by pressing CH UP button and then "PLAY" button on the unit. Adjust the height of Guide Rollers [2] and [3] (Fig. 5-4-3, Page 5-6) watching the oscilloscope display so that the envelope becomes as flat as possible. To do this adjustment, turn the top of the Guide Roller with the Guide Roller Adj. Screwdriver.
- If the envelope is as shown in Fig. 5-4-7, adjust the height of Guide Roller [2] (Refer to Fig. 5-4-3) so that the waveform looks like the one shown in Fig. 5-4-9.
- If the envelope is as shown in Fig. 5-4-8, adjust the height of Guide Roller [3] (Refer to Fig. 5-4-3) so that the waveform looks like the one shown in Fig. 5-4-9.

- When Guide Rollers [2] and [3] (Refer to Fig. 5-4-3) are aligned properly, there is no envelope drop either at the beginning or end of track as shown in Fig. 5-4-9.

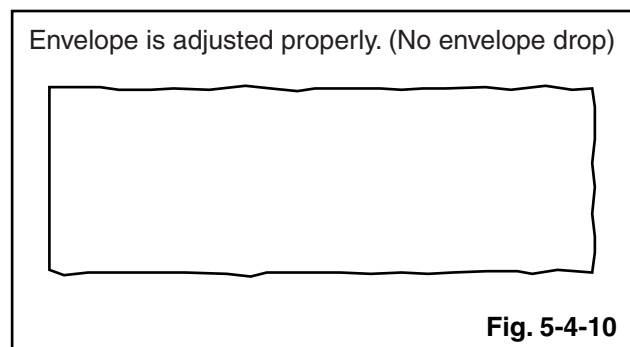
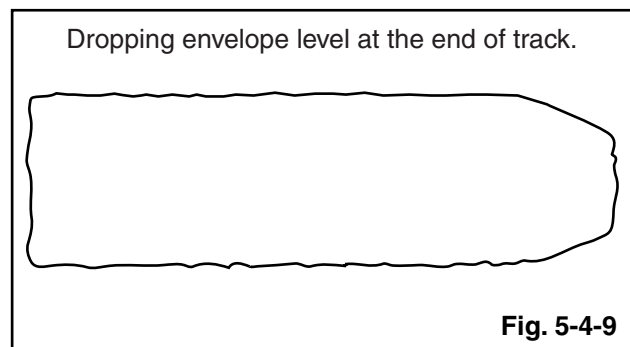
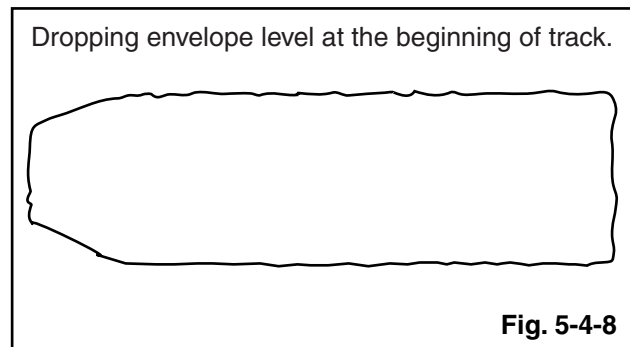

Note: Upon completion of the adjustment of Guide Rollers [2] and [3] (Refer to Fig. 5-4-3), check the X Value by pushing the CH UP or DOWN buttons alternately, to check the symmetry of the envelope. Check the number of pushes to ensure preset position. The number of pushes CH UP button to achieve 1/2 level of envelope should match the number of pushes CH DOWN button from center. If required, redo the "X Value Alignment."

1-D. Azimuth Alignment of Audio/Control/ Erase Head

Purpose:

To correct the Azimuth alignment so that the Audio/Control/Erase Head meets tape tracks properly.

Symptom of Misalignment:

If the position of the Audio/Control/Erase Head is not properly aligned, the Audio S/N Ratio or Frequency Response will be poor.

1. Connect the oscilloscope to the audio output jack on the rear side of the deck.
2. Playback the alignment tape (MH-2) and confirm that the audio signal output level is 8kHz.
3. Adjust Azimuth Adj. Screw so that the output level on the AC Voltmeter or the waveform on the oscilloscope is at maximum. (Fig. 5-4-6)

Note: Upon completion of the adjustment of Azimuth Adj. Screw, check the X Value by pushing the CH UP or DOWN buttons alternately, to check the symmetry of the envelope. Check the number of pushes to ensure preset position. The number of pushes CH UP button to achieve 1/2 level of envelope should match the number of pushes CH DOWN button from center. If required, redo the "X Value Alignment."

1-E. Checking and Alignment of Tape Path during reversing

Purpose:

To make sure that the tape path is well stabilized during reversing.

Symptom of Misalignment:

If the tape path is unstable during reversing, the tape will be damaged.

Note: Do not use an Alignment Tape for this procedure. If the unit is not correctly aligned, the tape may be damaged.

1. Insert a black cassette tape into the tray and set the unit to REV. Then confirm if the tape has been curled up or bent at the Take-up Guide Post[4] or REV Post[5]. (Refer to Fig. M11 and M12.)

2. When the tape has been curled up or bent, turn the alignment screw to adjust the height of REV Post. (Refer to Fig. M11 and M13.)

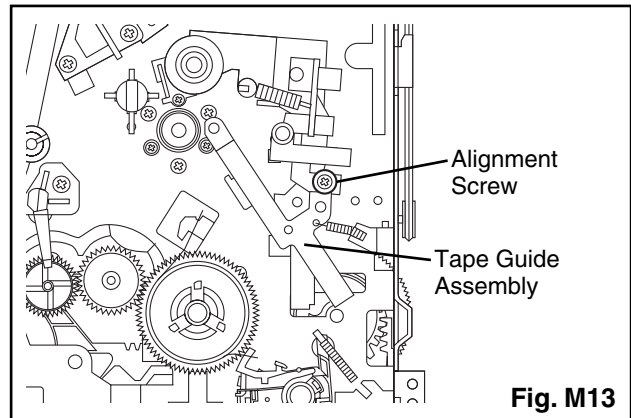
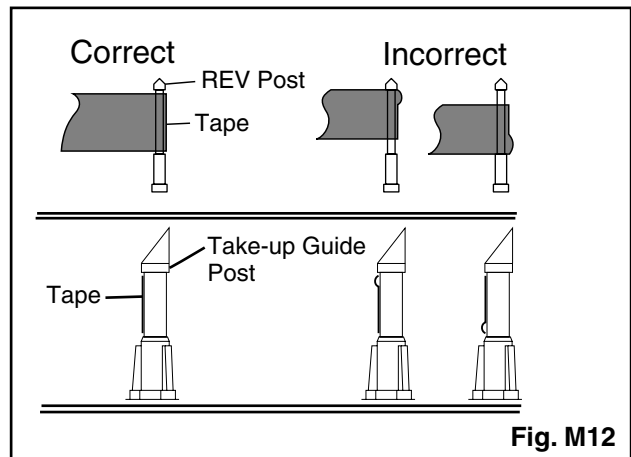
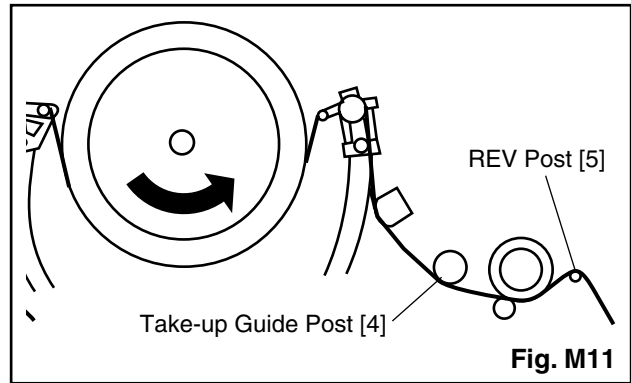

6-1 EXPLODED VIEWS

6-1-1 Cabinet Section

Note: Components without any numbers in exploded views had not been assigned as service parts as of the date of issue of this manual.

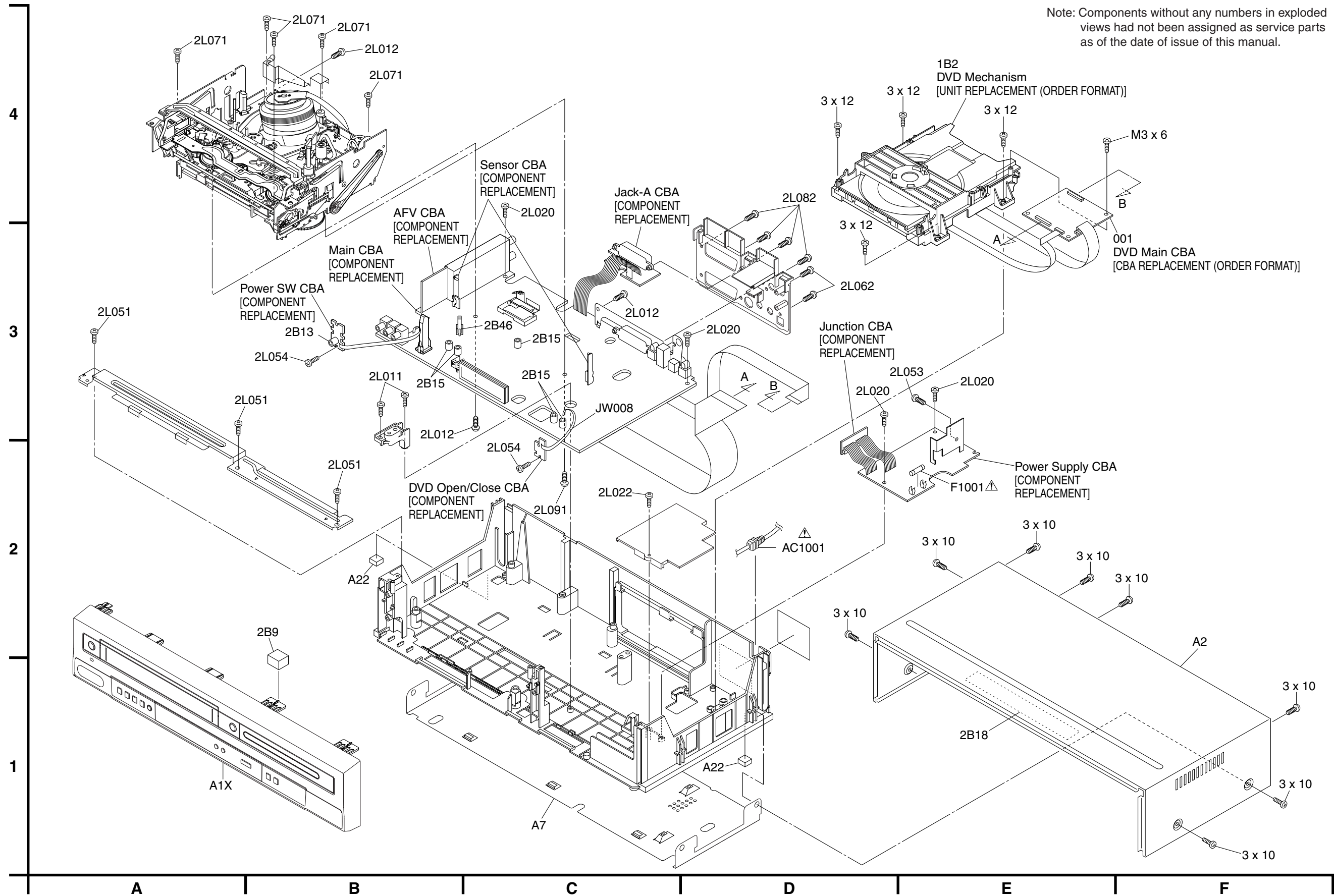

6-1-2 Deck Mechanism View 1 Section

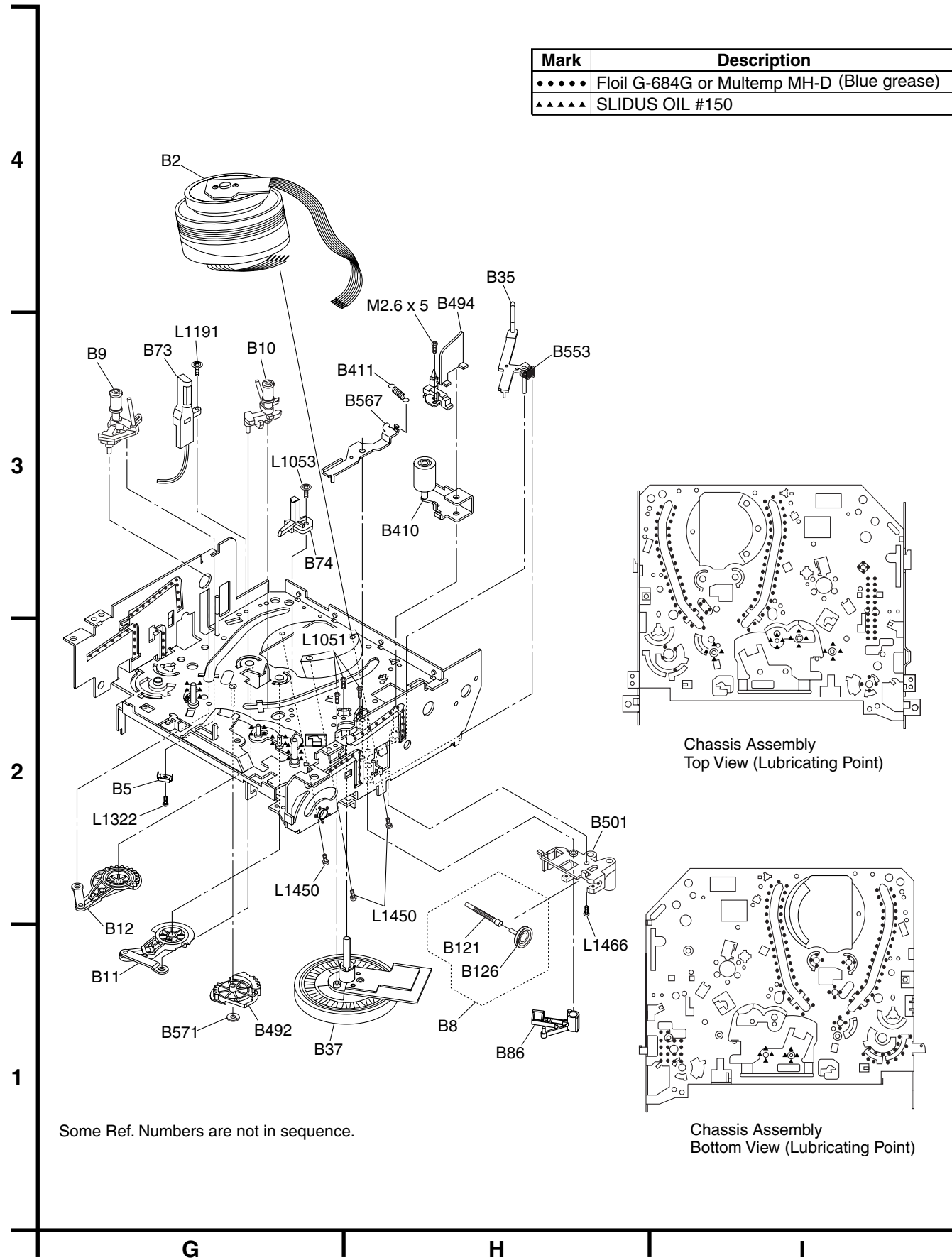

6-1-3 Deck Mechanism View 2 Section

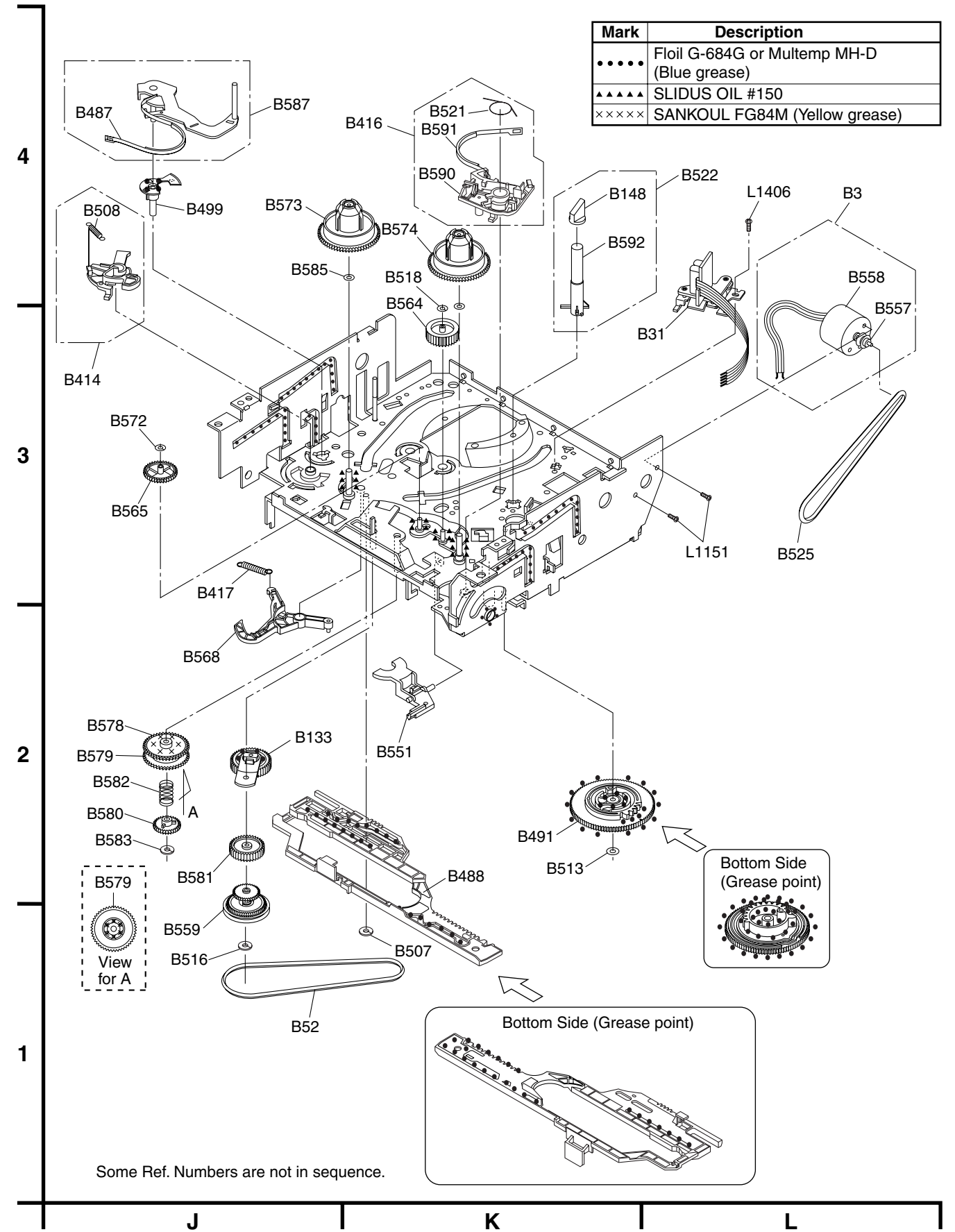

6-1-4 Deck Mechanism View 3 Section

Mark	Description
•••••	Foil G-684G or Multemp MH-D (Blue grease)
▲▲▲▲▲	SLIDUS OIL #150

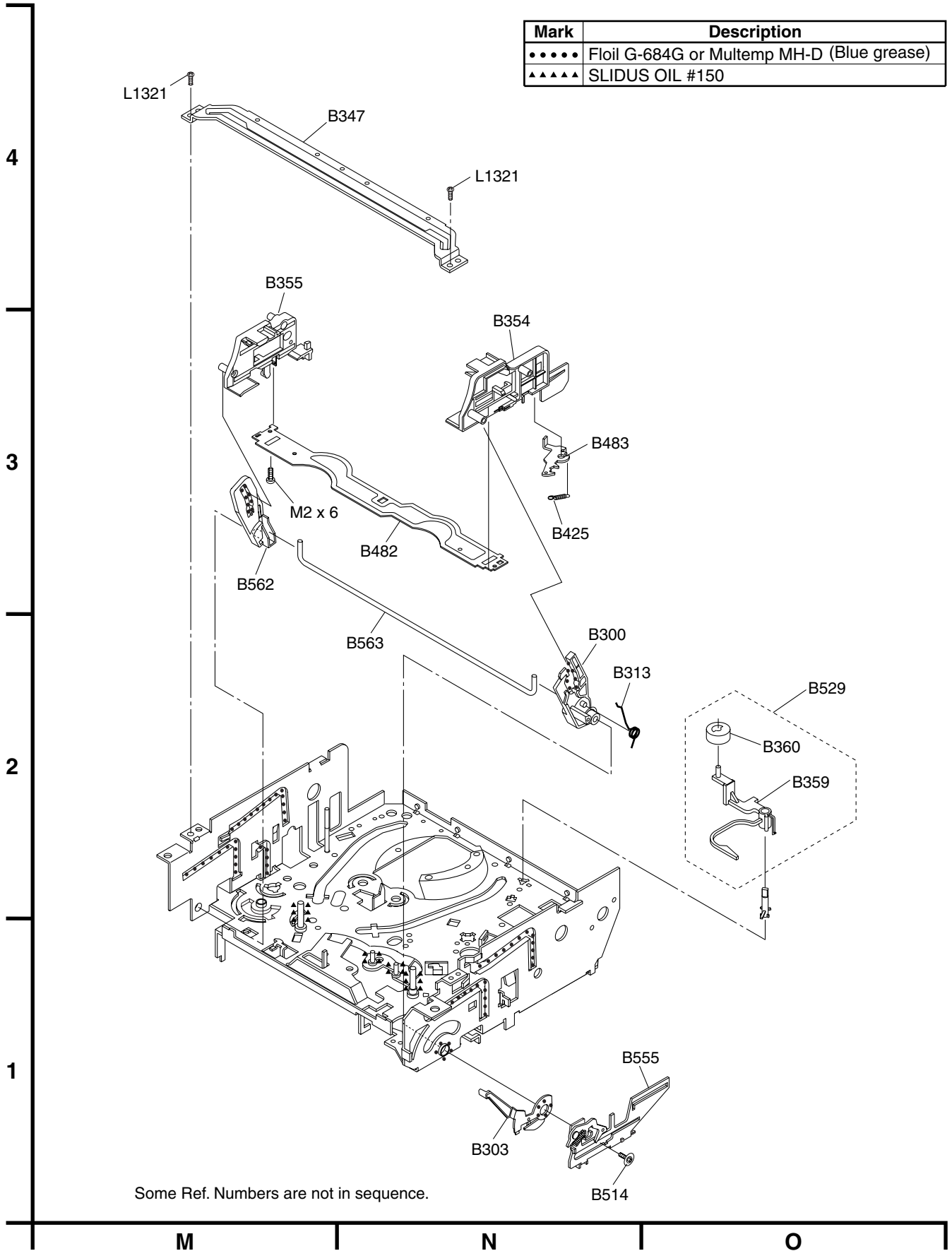

6-2 REPLACEMENT PARTS LIST

6-2-1 Mechanical Parts List

Note: Products marked with a \triangle have special characteristics important to safety.

SYMBOL-NO	DESCRIPTION	SYMBOL-NO	DESCRIPTION
MECHANISM SECTION		B360	ROLLER,CLEANER
A1X	PANEL,FRONT	B410	ARM,PINCH(A)
A2	CASE, TOP	B411	SPRING,PINCH
A7	PANEL,BOTTOM	B414	BRAKE(M)
		B416	BRAKE ASSY
A22	FOOT,CHASSIS	B417	SPRING,TENSION
\triangle AC1001	CORD,AC	B425	SPRING,LOCK LEVER
1B2	DVD DRIVE MECHA	B482	PLATE,CASSETTE
2B9	CUSHION	B483	LEVER,LOCK
2B13	BUSH,LED(E)	B487	BRAKE,BAND
2B15	BUSH,LED	B488	LEVER,MODE
2B18	CASE,FIBER	B491	GEAR,CAM(A)
2B46	HOLDER	B492	GEAR,MODE
2L011	SCREW (3X8)	B494	OPENER,DOOR(C)
2L012	SCREW (3X6)	B499	HOLDER,LEVER(T)
2L020	SCREW (3X8)	B501	HOLDER,WORM
2L022	SCREW (3X8)	B507	WASHER
2L051	SCREW(M3X6)	B508	SPRING,BRAKE(S)
2L053	SCREW(3X8)	B513	WASHER
2L054	SCREW(M3X6)	B514	SCREW,RACK
2L062	SCREW(M3X10)	B516	WASHER
2L071	SCREW(3X10)	B518	WASHER
2L082	SCREW(M3X10)	B521	SPRING,BRAKE
2L091	SCREW(M3X8)	B522	POST ASSY
B2	CYLINDER ASSY	B525	BELT
B3	MOTOR,LOADING ASSY	B529	CLEANER ASSY
B5	PLATE,SLIDE	B551	ARM,FF
B8	PULLEY ASSY	B553	SPRING
B9	GUIDE,MOVING(S)	B555	RACK ASSY
B10	GUIDE,MOVING(T)	B557	PULLEY,MOTOR
B11	ARM,LOADING(TU)	B558	MOTOR,LOADING
B12	ARM,LOADING(SP)	B559	CLUTCH ASSY
B31	HEAD,AC	B562	LEVER,DRIVE(C)
B35	ARM,GUIDE TAPE	B563	SHAFT,SLIDER
B37	MOTOR,CAPSTAN	B564	GEAR(M)
B52	BELT,CAP	B565	GEAR,SENSOR
B73	HEAD,FE	B567	ARM,PINCH
B74	PRISM	B568	ARM,BT
B86	BRAKE ASSY	B571	WASHER
B121	WORM	B572	WASHER
B126	PULLEY	B573	REEL(S)
B133	IDLER ASSY	B574	REEL(T)
B148	TG CAP	B578	GEAR(A)
B300	LEVER,DRIVE(C)	B579	GEAR(B)
B303	DOOR OPENER(F)	B580	GEAR(C)
B313	SPRING,DRIVE(C)	B581	GEAR,CENTER
B347	HOLDER,GUIDE	B582	SPRING,GEAR
B354	SLIDER(TU)	B583	WASHER,CAM
B355	LEVER,CLEANER	B585	WASHER
B359	LEVER,CLEANER	B587	LEVER,TENSION

SYMBOL-NO	DESCRIPTION	SYMBOL-NO	DESCRIPTION
B590	ARM,BRAKE		
B591	BRAKE,BAND		
B592	POST		
L1051	SCREW(M2.6X6)		
L1053	SCREW(M2.6X8)		
L1151	SCREW(M2.6X4)		
L1191	SCREW(M2.6X8)		
L1321	SCREW (3X6)		
L1322	SCREW(M2.3X4)		
L1406	HEAD,AC		
L1450	SCREW M2.6X5		
L1466	SCREW(M2.6X6)		
001	PWB ASSY DVD MAIN		
ACCESSORIES			
X1	REMOTE HAND SET		
X3	CORD,RF		

**THE UPDATED PARTS LIST
FOR THIS MODEL IS
AVAILABLE ON ESTA**

7-1 SYSTEM CONTROL TIMING CHARTS

[VCR Section]

Mode SW : LD-SW

LD-SW Position detection A/D Input voltage Limit (Calculated voltage)	Symbol
3.76V~4.50V (4.12V)	EJ
4.51V~5.00V (5.00V)	CL
0.00V~0.25V (0.00V)	SB
1.06V~1.50V (1.21V)	TL
0.66V~1.05V (0.91V)	FB
1.99V~2.60V (2.17V)	SF
1.51V~1.98V (1.80V)	SM
3.20V~3.75V (3.40V)	AU
0.26V~0.65V (0.44V)	AL
4.51V~5.00V (5.00V)	SS
2.61V~3.19V (2.97V)	RS

↑ Note:

Note:

EJ → RS: Loading FWD (LM-FWD/REV "H")

RS → EJ: Loading REV (LM-FWD/REV "L")

Stop (A) = Loading

Stop (B) = Unloading

Note:

Symbol	Loading Status
EJ	Eject
CL	Eject ~ REW Reel
SB	REW Reel ~ Stop(B)
TL	Stop(B) ~ Brake Cancel
FB	Brake Cancel ~ FF / REW
SF	FF / REW ~ Stop(M), (FF / REW)
SM	Stop(M), (FF / REW) ~ Stop(A)
AU	Stop(A) ~ Play / REC
AL	Play / REC ~ Still / Slow
SS	Still / Slow ~ RS (REW Search)
RS	RS (REW Search)

Still/Slow Control Frame Advance Timing Chart

1) SP Mode

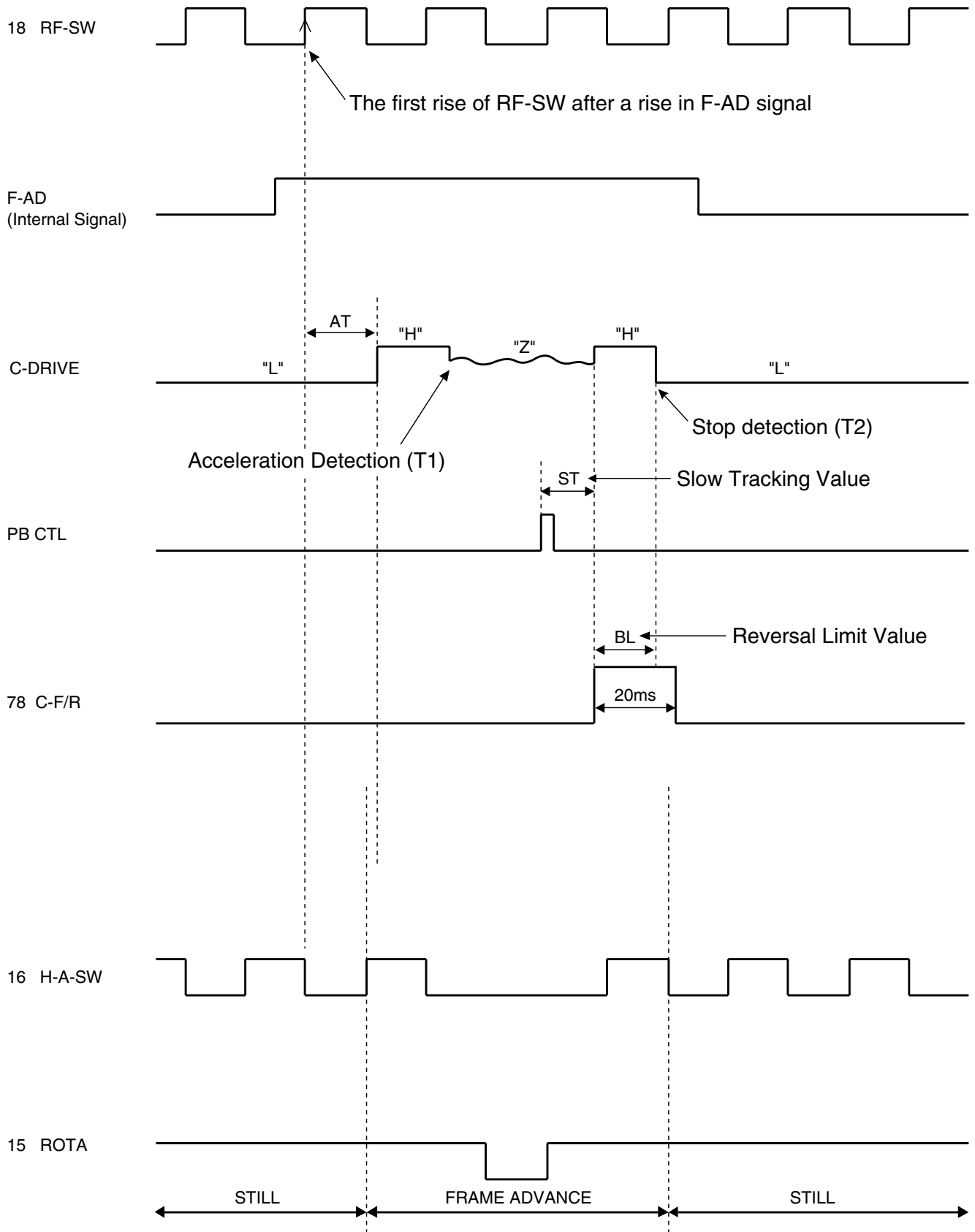

Fig. 1

2) LP Mode

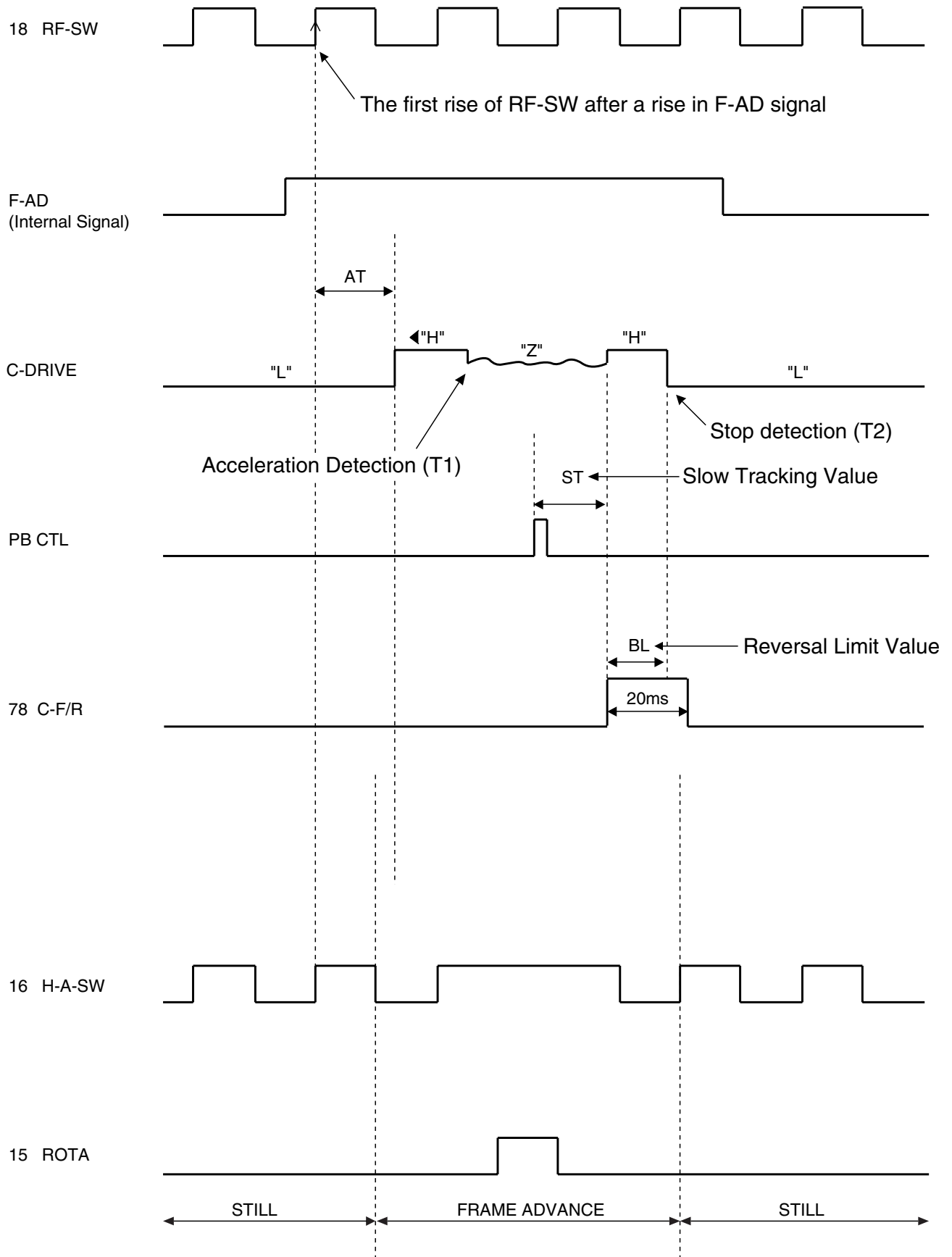

Fig. 2

2. STOP(A) -> FF -> STOP(A) -> REW -> STOP(A) -> REC -> PAUSE -> PAUSE or REC -> STOP(A) -> EJECT

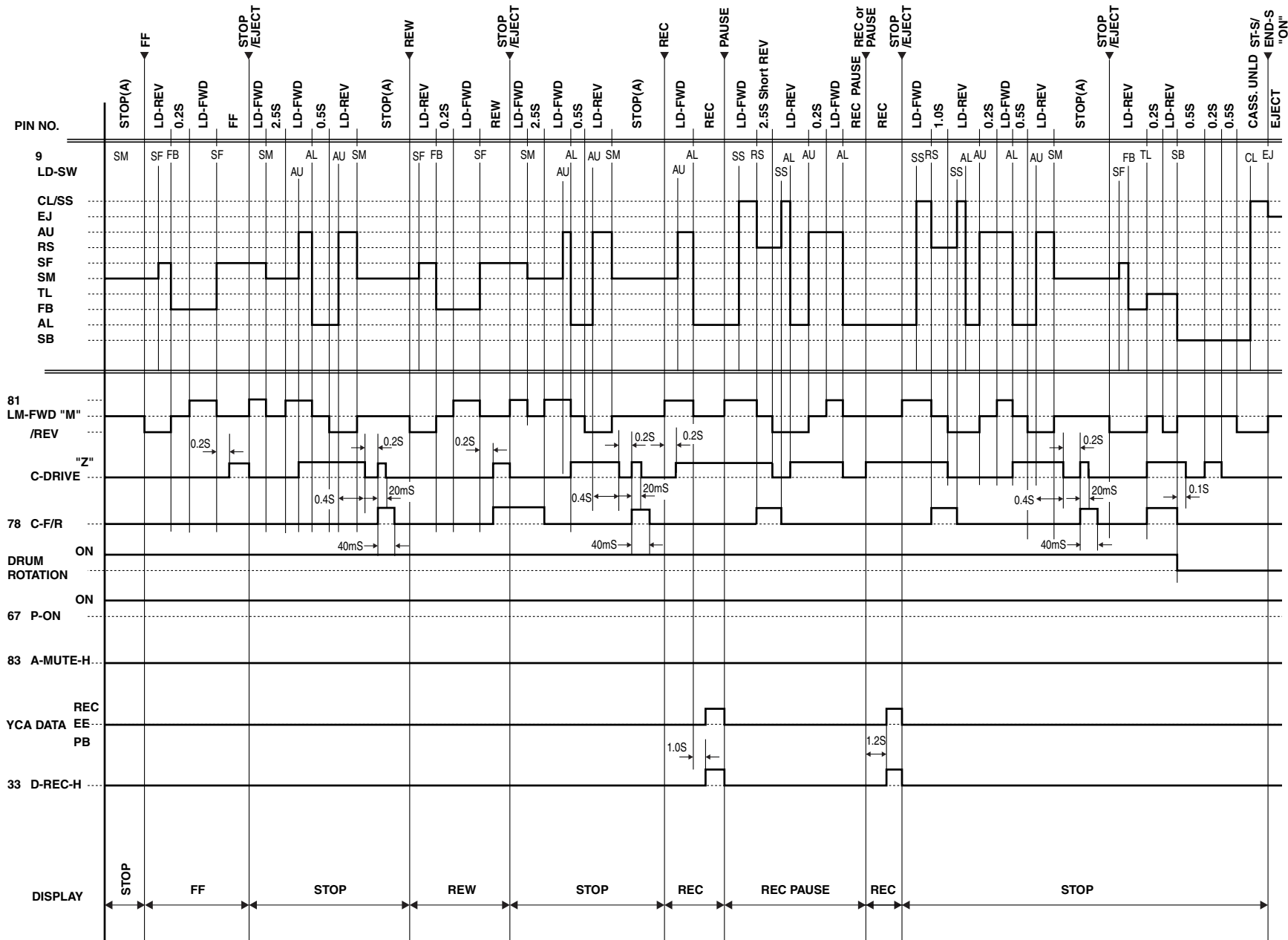
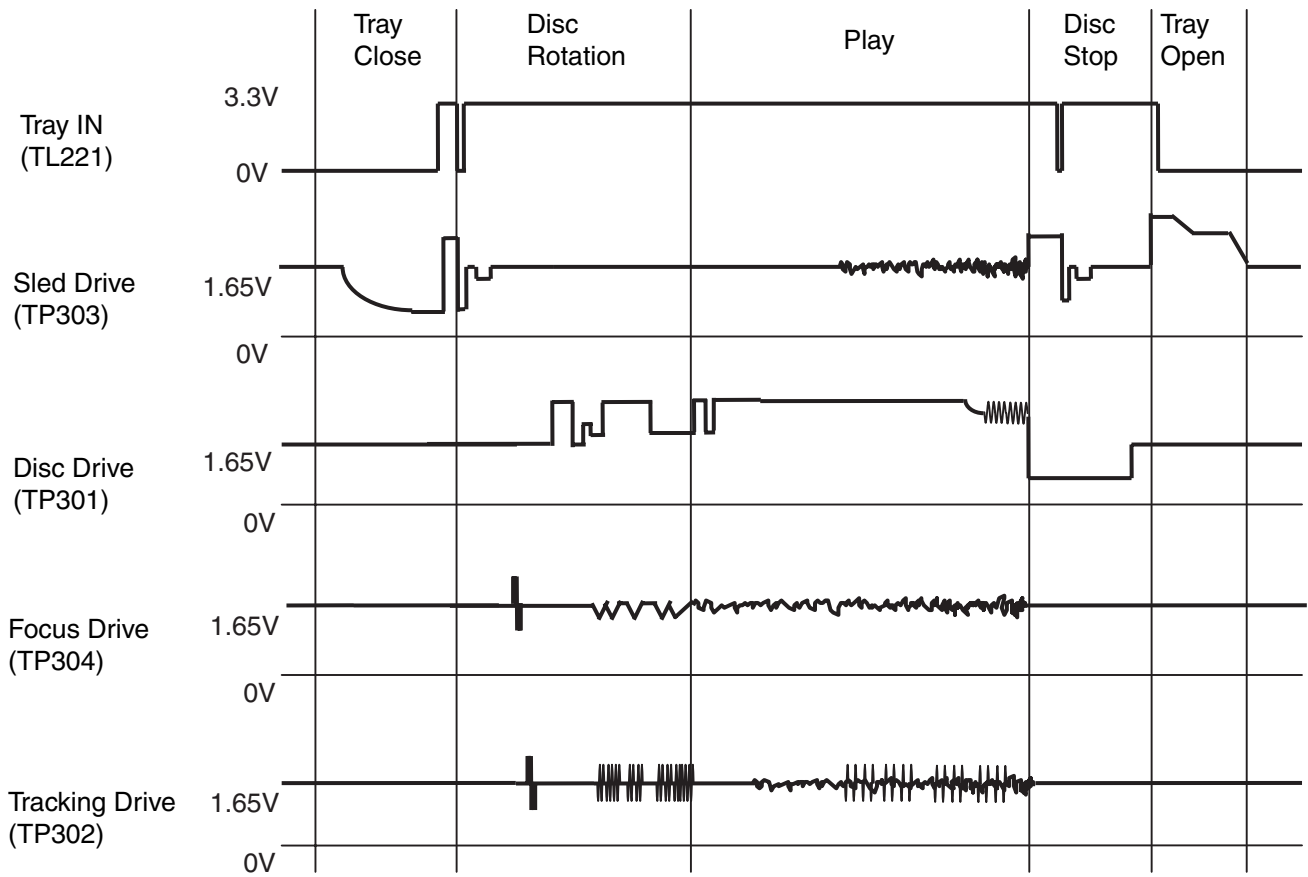

Fig. 4

[DVD Section]

Tray Close ~ Play / Play ~ Tray Open



7-2 IC PIN FUNCTION DESCRIPTIONS

[VCR Section]

IC501(SERVO / SYSTEM CONTROL IC)

“H” ≥ 4.5V, “L” ≤ 1.0V

Pin No.	IN/OUT	Signal Name	Function	Active Level
1	IN	SC2-IN	Input Signal from Pin 8 of SCART2	A/D
2	IN	PG-Delay	Video Head Switching Pulse Signal Adjusted Voltage	A/D
3	IN	POW-SAF	P-ON Power Detection Input Signal	A/D
4	IN	END-S	Tape End Position Detect Signal	A/D
5	IN	AFC	Automatic Frequency Control Signal	A/D
6	IN	V-ENV	Video Envelope Comparator Signal	A/D
7	IN	KEY-1	Key Scan Input Signal 1	A/D
8	IN	KEY-2	Key Scan Input Signal 2	A/D
9	IN	LD-SW	Deck Mode Position Detector Signal	A/D
10	IN	ST-S	Tape Start Position Detector Signal	A/D
11	-	NU	Not Used	-
12	-	NU	Not Used	-
13	OUT	D-V- SYNC	Dummy V-sync Output	H/Hi-z
14	IN	REMOTE-VIDEO	Remote Control Sensor	L
15	OUT	C-ROTA	Color Phase Rotary Changeover Signal	H/L
16	OUT	H-A-SW	Video Head Amp Switching Pulse	H/L
17	IN	H-A-COMP	Head Amp Comparator Signal	H/L
18	OUT	RF-SW	Video Head Switching Pulse	H/L
19	OUT	Hi-Fi-H-SW	HiFi Audio Head Switching Pulse	H/L
20	-	NU	Not Used	-
21	OUT	DVD-POWER	DVD Power Control Signal	H
22	-	NU	Not Used	-
23	-	NU	Not Used	-
24	-	NU	Not Used	-

Pin No.	IN/OUT	Signal Name	Function	Active Level
25	OUT	TIMER-LED	“TIMER” LED Signal Output	H/L
26	OUT	REC- LED	“REC” LED Signal Output	H/L
27	-	NU	Not Used	-
28	OUT	LINE-MUTE	Audio Mute Control Signal	H
29	OUT	DVD-LED	“DVD” LED Signal Output	H/L
30	OUT	VCR-LED	“VCR” LED Signal Output	H/L
31	IN	REC-SAF-SW	Recording Safety SW Detect (With Record tab=“L”/ With out Record tab=“H”)	H/L
32	IN	A-MODE	Hi-Fi Tape Detection Signal	L
33	OUT	D-REC-H	Delayed Record Signal	H
34	IN	RESET	System Reset Signal (Reset=“L”)	L
35	IN	XCin	Sub Clock	-
36	OUT	XCOU	Sub Clock	-
37	-	Vcc	Vcc	-
38	IN	Xin	Main Clock Input	-
39	OUT	Xout	Main Clock Input	-
40	-	GND	Vss(GND)	-
41	-	NU	Not Used	-
42	IN	DVD-8PIN-IN	SCART 8Pin DVD Input Control Signal	H/L
43	IN	CLKSEL	Clock Select (GND)	L
44	IN	OSCin	Clock Input for letter size	-
45	OUT	OSCo	Clock Output for letter size	-
46	-	NU	Not Used	-
47	IN	LP	LP	-
48	IN	FSC-IN [4.43MHz]	4.43MHz Clock Input	-
49	-	OSDVss	OSDVss	-
50	IN	OSD-V-IN	OSD Video Signal Input	-
51	-	NU	Not Used	-
52	OUT	OSD-V-OUT	OSD Video Signal Output	-
53	-	OSDVcc	OSDVcc	-
54	-	HLF	LPF Connected Terminal (Slicer)	-
55	-	NU	Not Used	-

Pin No.	IN/OUT	Signal Name	Function	Active Level
56	IN	DAVN-L	VPS/PDC Data Receive = "L"	L
57	-	NU	Not Used	-
58	IN	C-SYNC	Composite Synchronized Pulse	PULSE
59	OUT	8POUT-1	Control SCART 1 8Pin Level by using 8POUT-1 and 8POUT-2	H/L
60	OUT	8POUT-2	Control SCART 1 8Pin Level by using 8POUT-1 and 8POUT-2	H/L
61	-	NU	Not Used	-
62	-	NU	Not Used	-
63	-	NU	Not Used	-
64	-	NU	Not Used	-
65	-	NU	Not Used	-
66	OUT	C-POW-SW	Capstan Power Switching Signal	H/L
67	OUT	P-ON-H	Power On Signal at High	H
68	OUT	DRV-DATA	VFD Driver IC Control Data	H/L
69	OUT	DRV-STB	VFD Driver IC Chip Select Signal	H/L
70	OUT	DRV-CLK	VFD Driver IC Control Clock	H/L
71	OUT	IIC-BUS-SCL	IIC BUS Control Clock	H/L
72	IN/OUT	IIC-BUS-SDA	IIC BUS Control Data	H/L
73	-	NU	Not Used	-
74	-	NU	Not Used	-
75	IN	DVD-POWER-MONITOR	DVD Power Monitor Signal (P-off="L", P-on="H")	H/L
76	OUT	C-CONT	Capstan Motor Control Signal	PWM
77	OUT	D-CONT	Drum Motor Control Signal	PWM
78	OUT	C-F/R	Capstan Motor FWD/REV Control Signal (FWD="L"/REV="H")	H/L
79	IN	S-REEL	Supply Reel Rotation Signal	PULSE
80	IN	T-REEL	Take Up Reel Rotation Signal	PULSE
81	OUT	LM-FWD/REV	Loading Motor Control Signal	H/L/Hi-z
82	OUT	OUTPUT-SELECT	Output Select	H/L
83	OUT	A-MUTE-H	Audio Mute Control Signal (Mute = "H")	H

Pin No.	IN/OUT	Signal Name	Function	Active Level
84	-	NU	Not Used	-
85	-	NU	Not Used	-
86	IN	P-DOWN-L	Power Voltage Down Detector Signal	L
87	IN	C-FG	Capstan Motor Rotation Detection Pulse	PULSE
88	-	NU	Not Used	-
89	-	NU	Not Used	-
90	IN	D-PFG	Drum Motor Phase/Frequency Generator	PULSE
91	-	AMPVREF OUT	V-Ref for CTL AMP	-
92	-	AMPVREF in	V-Ref for CTL AMP	-
93	-	P80/C	P80/C Terminal	-
94	IN/OUT	CTL(-)	Playback/Record Control Signal (-)	H/L
95	IN/OUT	CTL(+)	Playback/Record Control Signal (+)	H/L
96	-	AMPC	CTL AMP Connected Terminal	-
97	-	CTLAMP out	To Monitor for CTL AMP Output	PULSE
98	-	AMPVcc	AMPVcc	-
99	-	AVcc	A/D Converter Power Input/ Standard Voltage Input	-
100	IN	AGC	IF AGC Control Signal	A/D

Notes:

Abbreviation for Active Level:

PWM -----Pulse Wide Modulation

A/D-----Analog - Digital Converter

IC612 (FIP DRIVER IC)

Pin No.	IN/ OUT	Signal Name	Name Function
1	IN	FP-CLK	Clock Input
2	IN	FP-STB	Serial Interface Strobe
3	-	NU	Not Used
4	-	NU	Not Used
5	-	VSS	GND
6	-	VDD	Power Supply
7	OUT	a	Segment Output
8		b	
9		c	
10		d	
11		e	
12		f	
13		g	
14		h	
15	-	VEE	Pull Down Level
16	OUT	i	Segment Output
17	OUT	7G	Grid Output
18		6G	
19		5G	
20		4G	
21		3G	
22		2G	
23		1G	
24	-	VDD	Power Supply
25	-	VSS	GND
26	IN	OSC	Oscillator Input
27	-	NU	Not Used
28	IN	FP-DIN	Serial Data Input

7-3 LEAD IDENTIFICATIONS

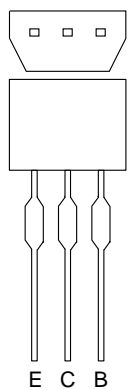

2SA1175(F,H,J)
2SC2785(F,H,J)
BA1F4M-T
BN1F4M-T
BN1L4M-T
KRA103M
KRC103M
KTA1266(GR)
KTA1267(GR,Y)
KTC3199(BL,GR,Y)

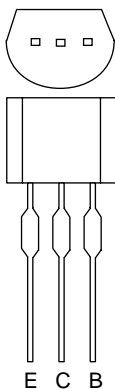

2SA1015-GR(TPE2)
2SA1020(Y)
2SC1815-BL(TPE2)
2SC1815-GR(TPE2)
2SC1815-Y(TPE2)
2SC2120-Y(TPE2)
2SC3266-Y(TPE2)
KTA1281(Y)
KTC3203(Y)
KTC3205(Y)

PQ070XZ5MZP

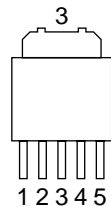

1: Vin
2: Vc
3: Vo
4: Vadj
5: GND

MID-32A22F
PT204-6B-12

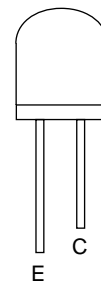

KIA4558P
NJM4558D

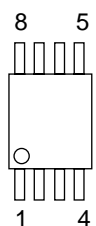

LC74793JM-TRM

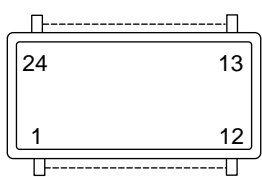

FMG4A T148
RN1511(TE85R)

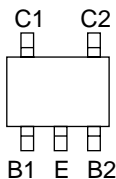

FA1F4M-T1B
KRC103S RTK
KTC3875Y-RTK

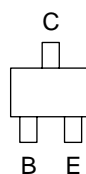

BR24L02F-WE2
CAT24WC02JI

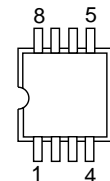

2SK3566

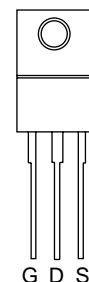

MM1637XVBE

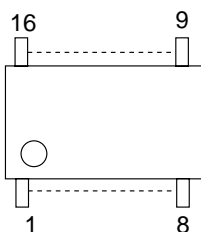

7-BT-298N

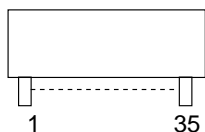

EL817A
EL817B
LTV-817B-F
PS2561A-1(Q,W)

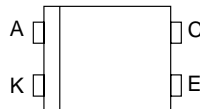

BA3948FP-E2

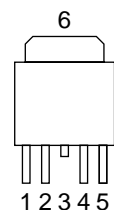

1: CTL
2: Vcc
3: N.C.
4: OUT
5: C
6: GND

BU4053BCF-E2
CD4053BCSJX
CD4053BNSR
TC4053BF(N)

MM1636XWRE

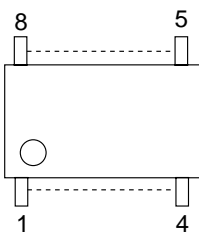

PT6313-S-TP

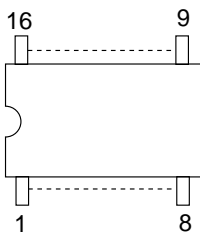
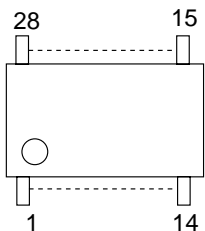

LA72648M-MPB-E

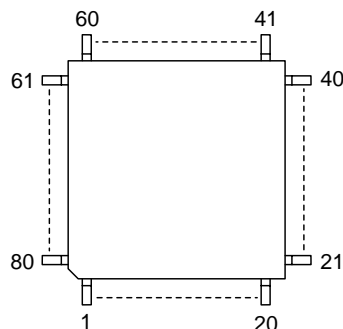

MSP3417G-QG-B8
MSP3417G-QG-B8-V3

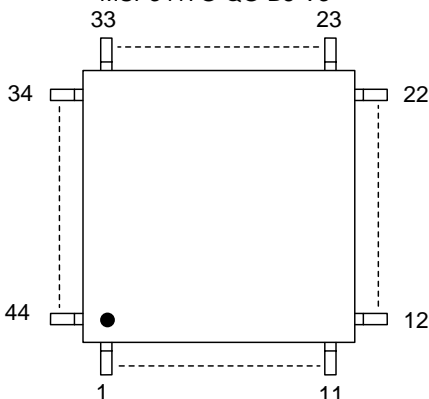

LA71750EM-MPB-E
QSZAA0RMB199

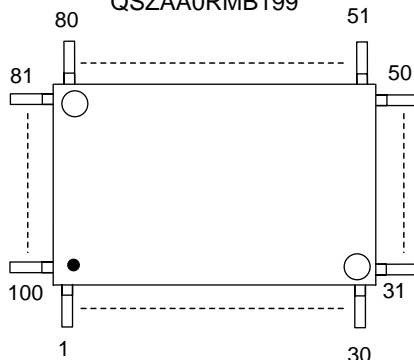

№

- A: Anode
- K: Cathode
- E: Emitter
- C: Collector
- B: Base
- R: Reference
- S: Source
- G: Gate
- D: Drain

S SCHEMATIC, WIRING DIAGRAMS

S-1 Schematic Diagrams / CBA's and Test Points

Standard Notes

WARNING

Many electrical and mechanical parts in this chassis have special characteristics. These characteristics often pass unnoticed and the protection afforded by them cannot necessarily be obtained by using replacement components rated for higher voltage, wattage, etc. Replacement parts that have these special safety characteristics are identified in this manual and its supplements; electrical components having such features are identified by the mark " ⚠ " in the schematic diagram and the parts list. Before replacing any of these components, read the parts list in this manual carefully. The use of substitute replacement parts that do not have the same safety characteristics as specified in the parts list may create shock, fire, or other hazards.

Capacitor Temperature Markings

Mark	Capacity change rate	Standard temperature	Temperature range
(B)	±10%	20°C	-25~+85°C
(F)	+30 - 80%	20°C	-25~+85°C
(SR)	±15%	20°C	-25~+85°C
(Z)	+30 - 80%	20°C	-10~+70°C

Notes:

1. Do not use the part number shown on these drawings for ordering. The correct part number is shown in the parts list, and may be slightly different or amended since these drawings were prepared.
2. All resistance values are indicated in ohms ($K=10^3$, $M=10^6$).
3. Resistor wattages are 1/4W or 1/6W unless otherwise specified.
4. All capacitance values are indicated in μF ($P=10^{-6} \mu F$).
5. All voltages are DC voltages unless otherwise specified.
6. Electrical parts such as capacitors, connectors, diodes, IC's, transistors, resistors, switches, and fuses are identified by four digits. The first two digits are not shown for each component. In each block of the diagram, there is a note such as shown below to indicate these abbreviated two digits.

Capacitors and transistors are represented by the following symbols.

CBA Symbols

(Top View) (Bottom View)

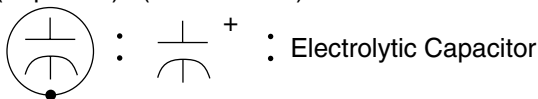

(Bottom View)

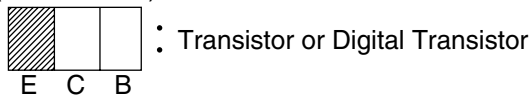

(Top View)

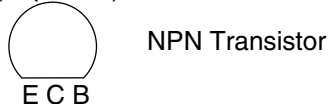

(Top View)

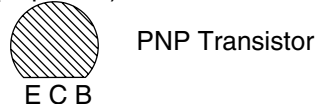

(Top View)

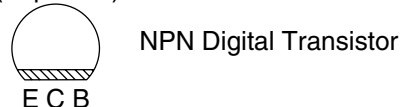

(Top View)



Schematic Diagram Symbols

Digital Transistor

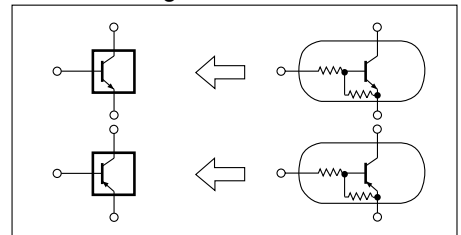

LIST OF CAUTION, NOTES, AND SYMBOLS USED IN THE SCHEMATIC DIAGRAMS ON THE FOLLOWING PAGES:

1. CAUTION:

FOR CONTINUED PROTECTION AGAINST FIRE HAZARD, REPLACE ONLY WITH THE SAME TYPE FUSE.

2. CAUTION:

Fixed Voltage (or Auto voltage selectable) power supply circuit is used in this unit.
If Main Fuse (F1001) is blown, first check to see that all components in the power supply circuit are not defective before you connect the AC plug to the AC power supply. Otherwise it may cause some components in the power supply circuit to fail.

3. Note:

- (1) Do not use the part number shown on the drawings for ordering. The correct part number is shown in the parts list, and may be slightly different or amended since the drawings were prepared.
- (2) To maintain original function and reliability of repaired units, use only original replacement parts which are listed with their part numbers in the parts list section of the service manual.

4. Voltage indications for PLAY and REC modes on the schematics are as shown below:

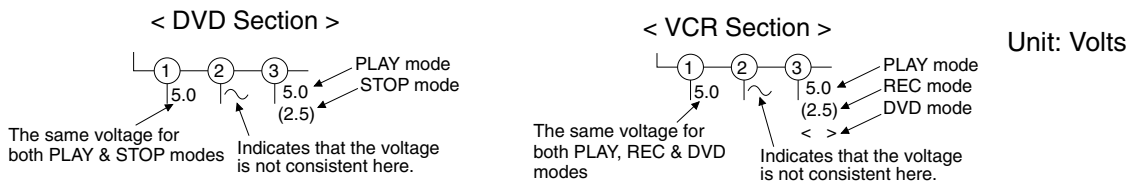

5. How to read converged lines

1-D3
 ↑ Distinction Area
 ↑ Line Number
 (1 to 3 digits)

Examples:

1. "1-D3" means that line number "1" goes to area "D3".
2. "1-B1" means that line number "1" goes to area "B1".

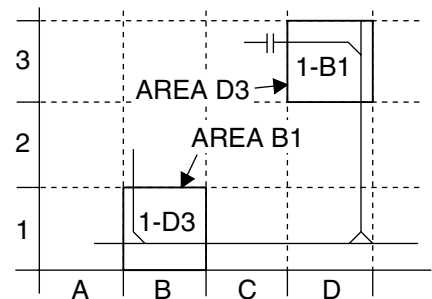

6. Test Point Information

- ⊙ : Indicates a test point with a jumper wire across a hole in the PCB.
- : Used to indicate a test point with a component lead on foil side.
- ⊘ : Used to indicate a test point with no test pin.
- : Used to indicate a test point with a test pin.

S-2 Wiring Diagrams < VCR SECTION >

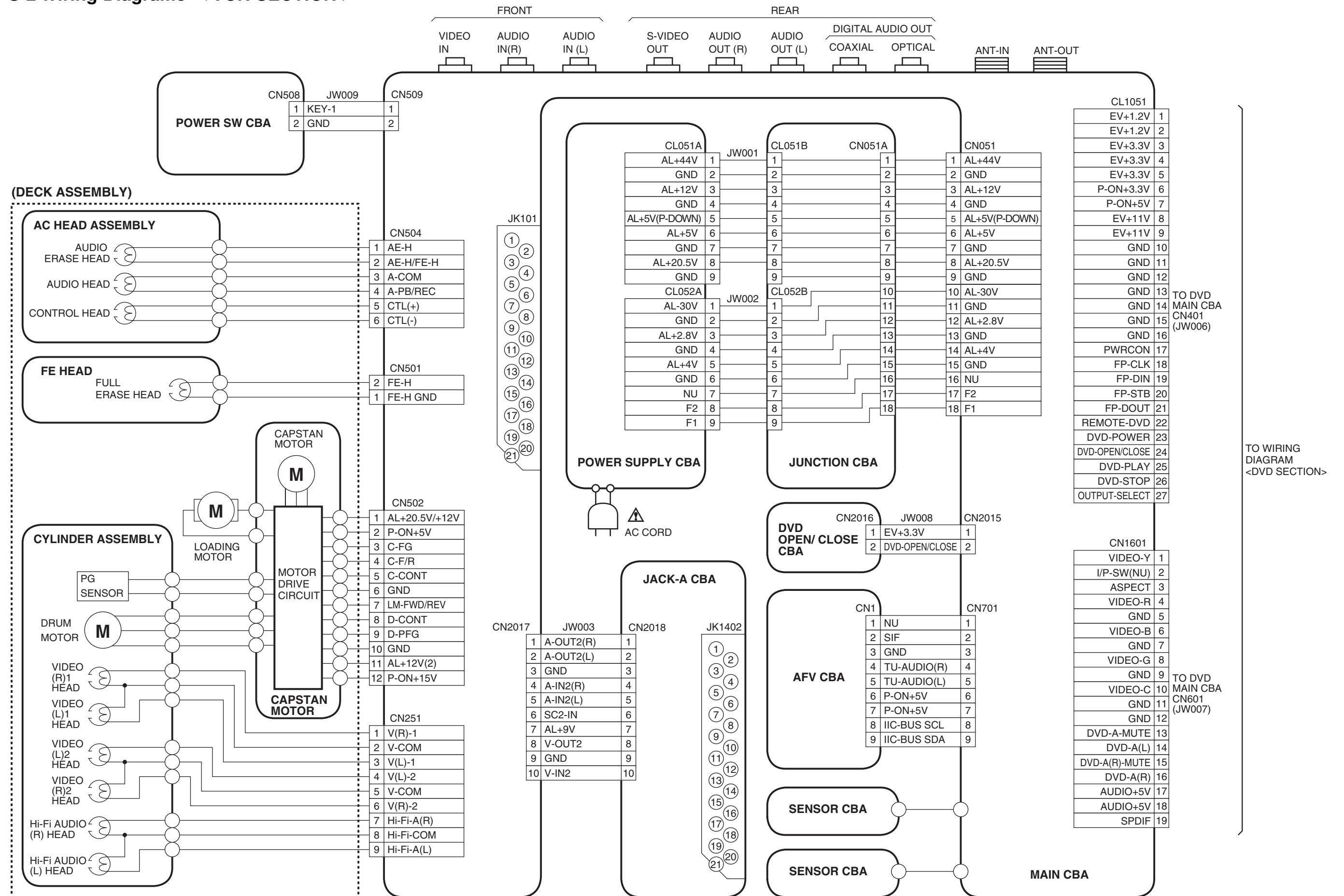

S-3 Wiring Diagrams < DVD SECTION >

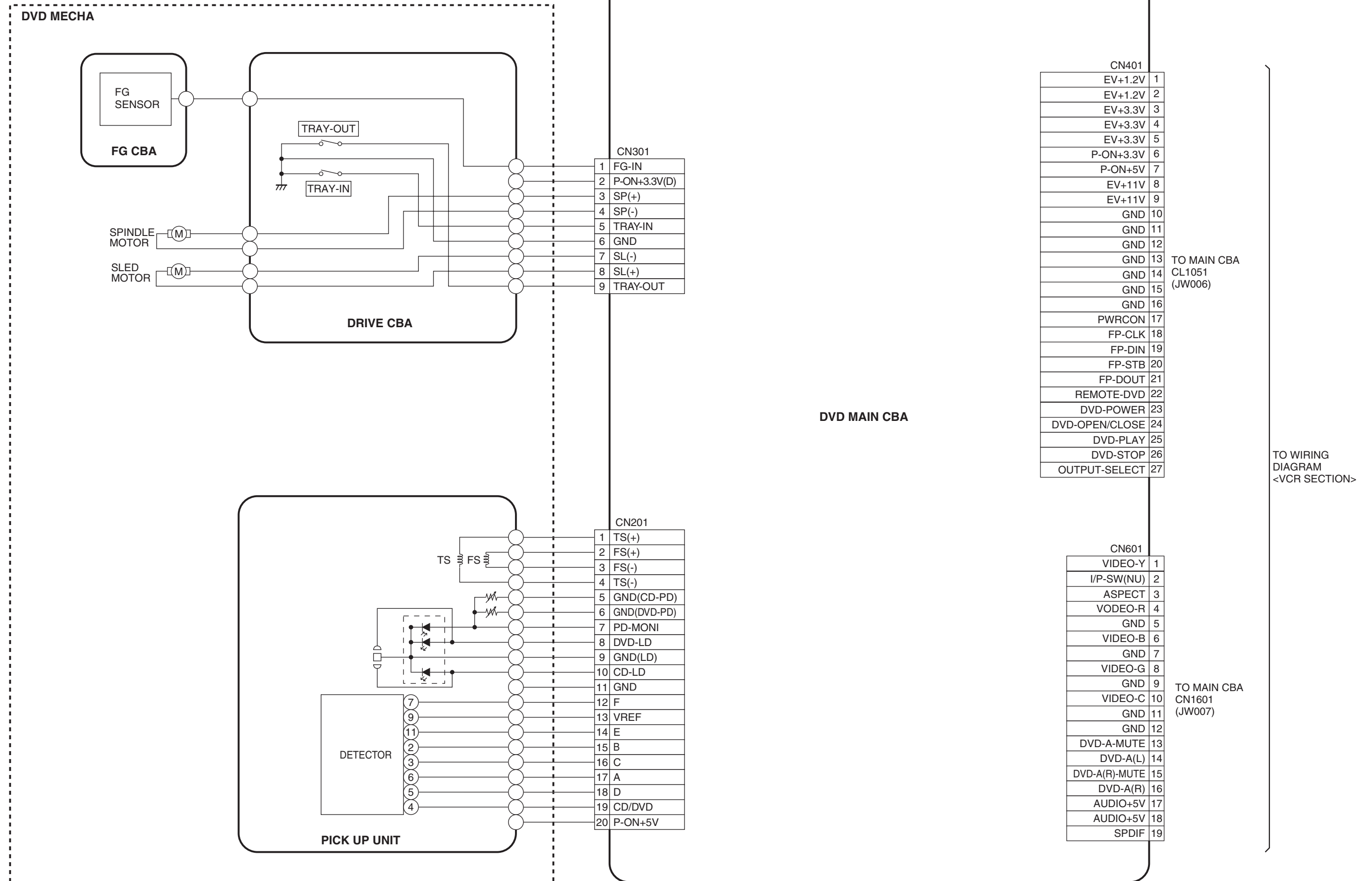

S-4 Main 1/9 Schematic Diagram

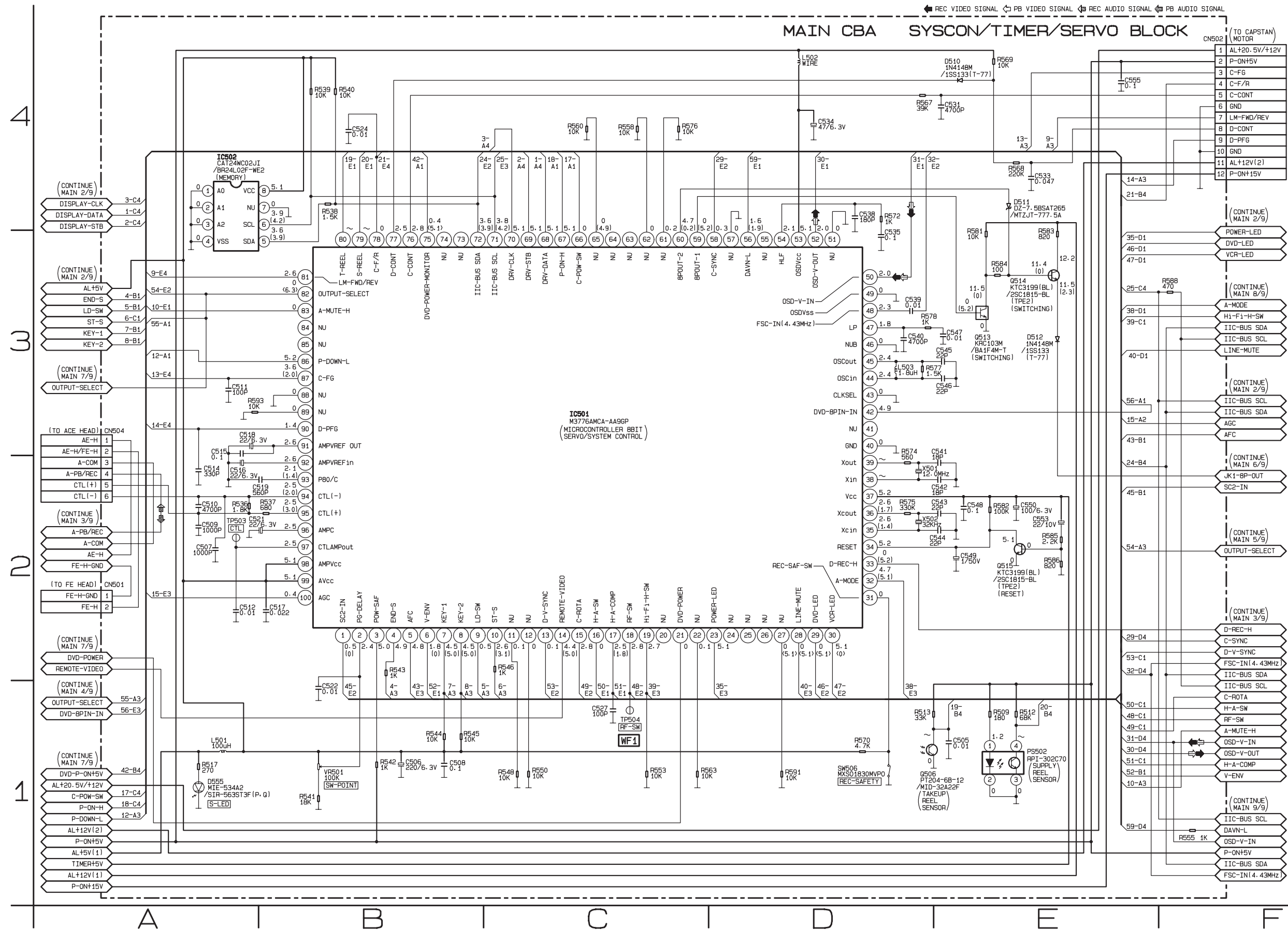

S-5 Main 2/9, Sensor & Power SW Schematic Diagrams

IC611 MATRIX CHART

	7G	6G	5G	4G	3G	2G	1G
a	∞	a	a	a	a	a	SACD
b	REPEAT	b	b	b	b	b	PSCAN
c	A-	c	c	c	c	c	DVD
d	B	d	d	d	d	d	A
e	ALL	e	e	e	e	e	P
f	A-B	f	f	f	f	f	M
g	▶	g	g	g	g	g	HD
h	■	GROUP	■	CHP	TRK.	V	
i	i	TITLE	VCR	■	Ⓢ	REC	CD

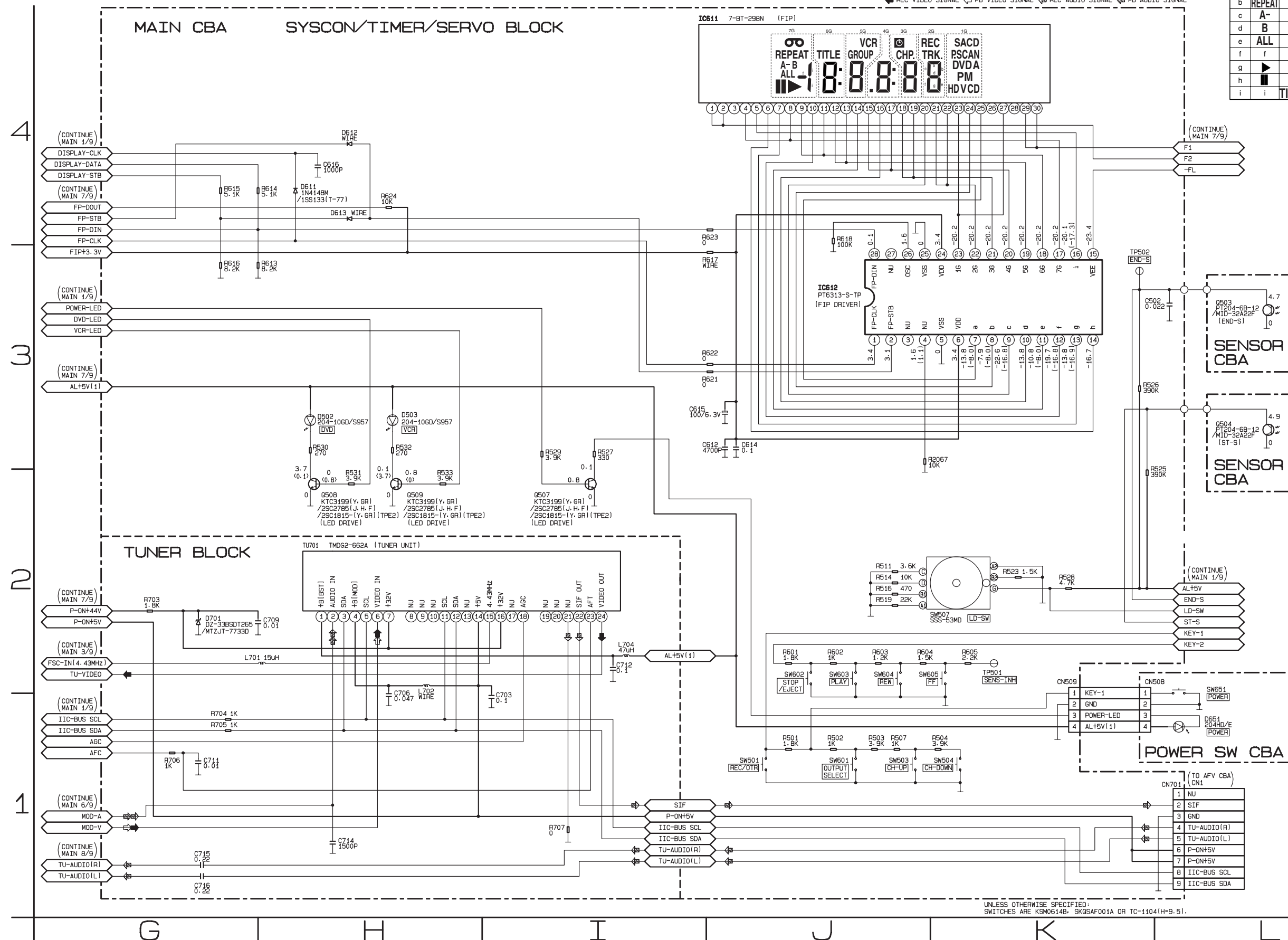

UNLESS OTHERWISE SPECIFIED:
SWITCHES ARE K5M0614B, SKGSAF001A OR TC-1104(H=9.5).

S-8 Main 5/9 Schematic Diagram

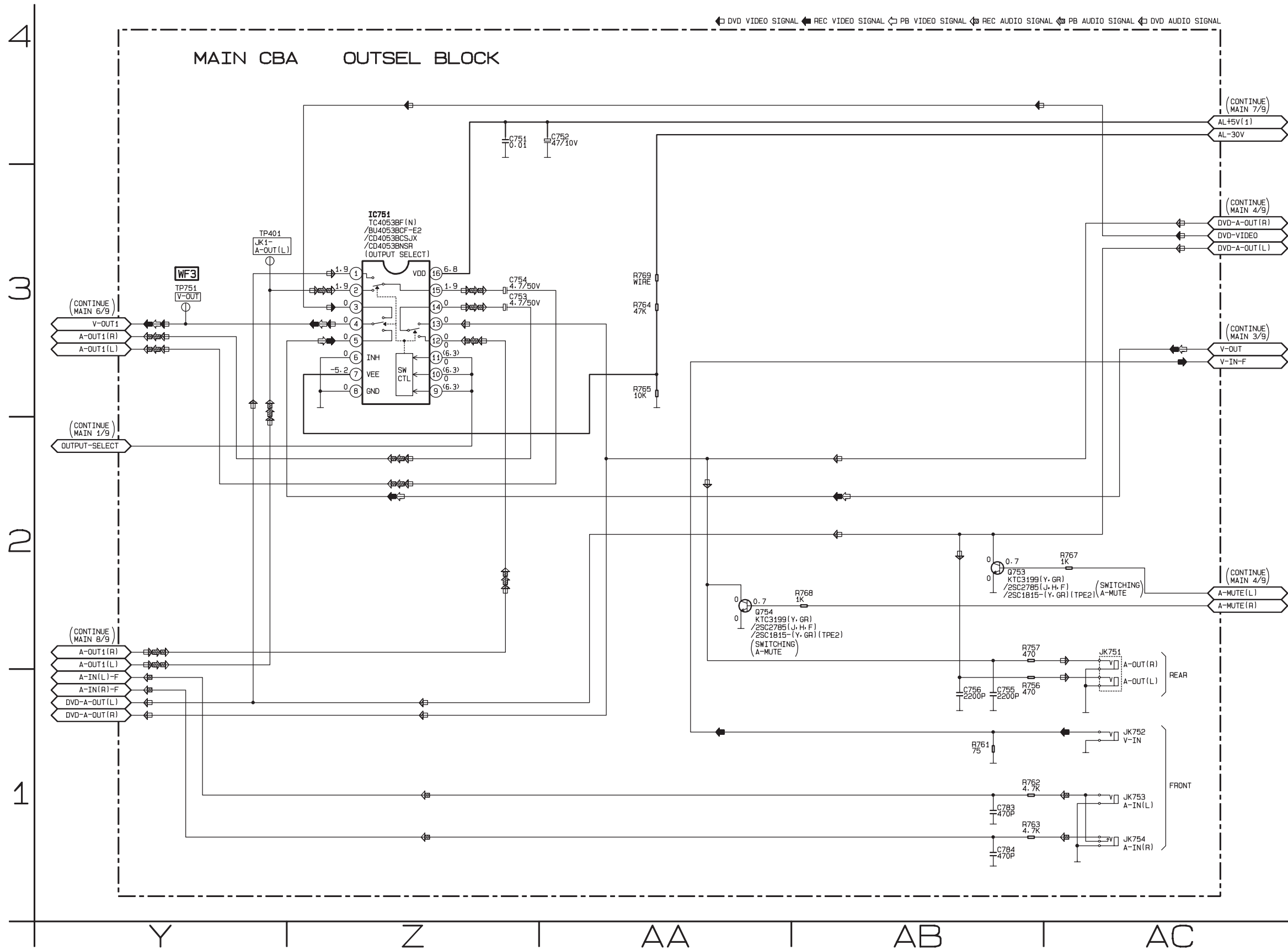

S-10 Main 7/9 & DVD Open/Close Schematic Diagrams

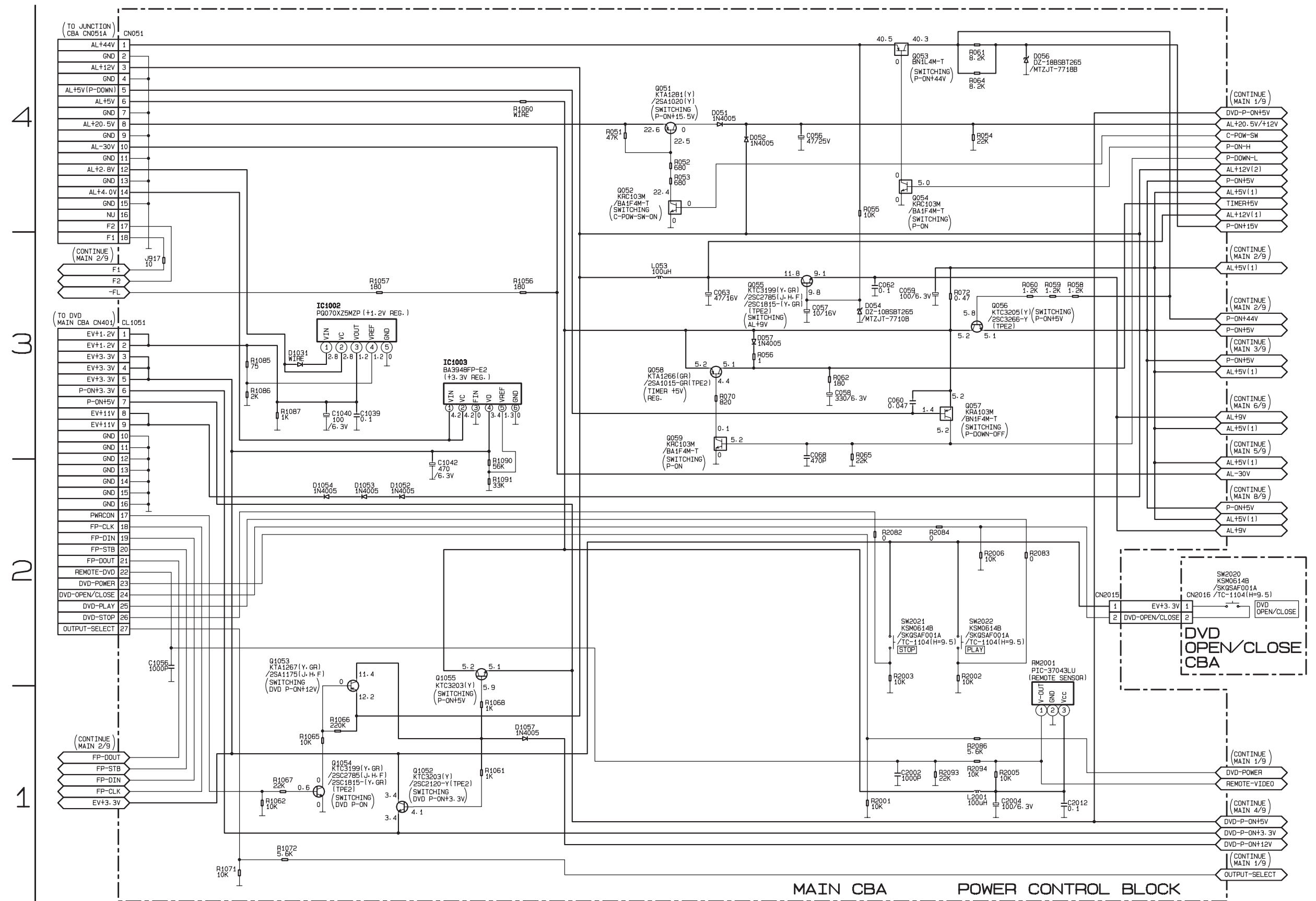

S-11 Main 8/9 Schematic Diagram

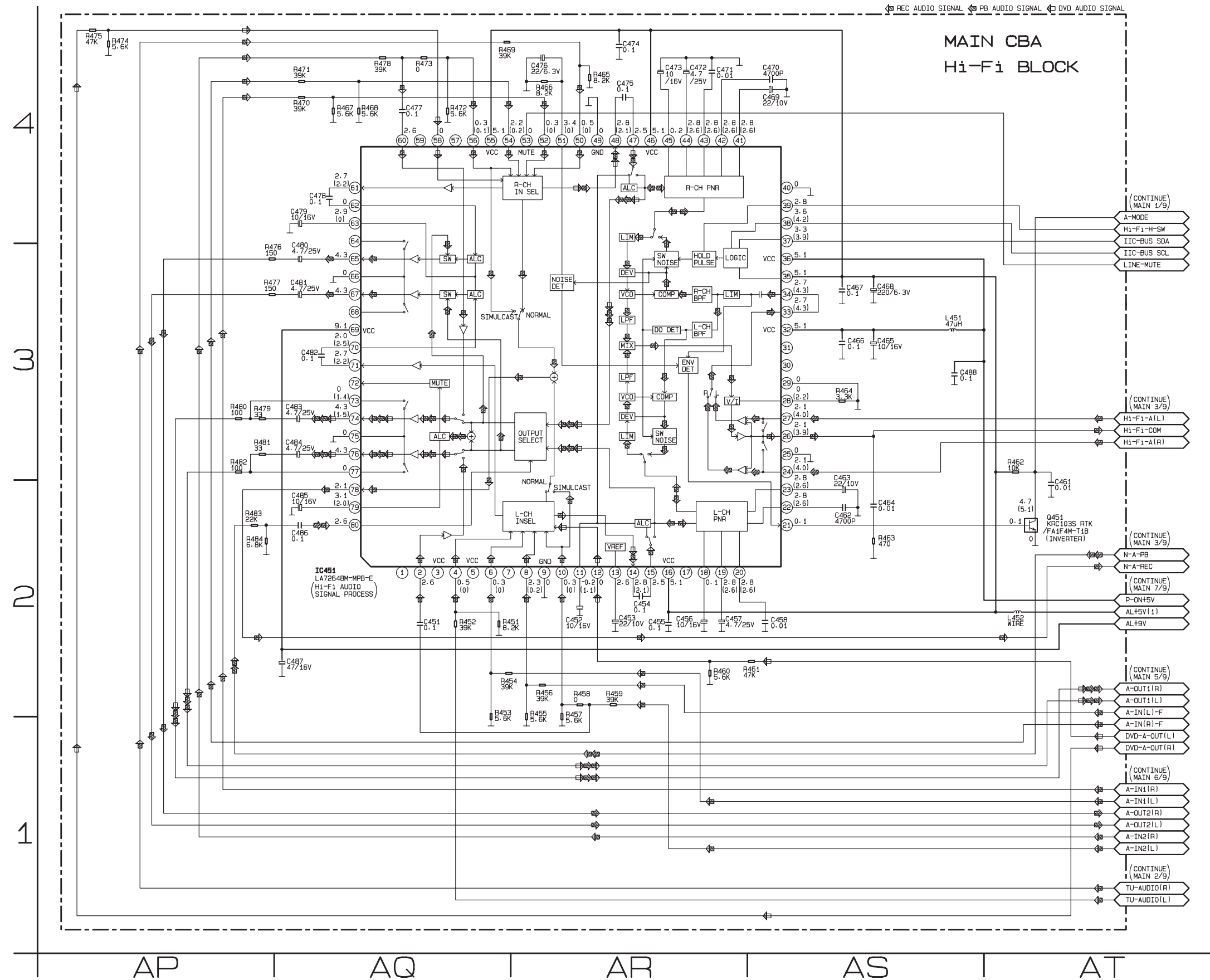

S-12 Main 9/9 Schematic Diagram

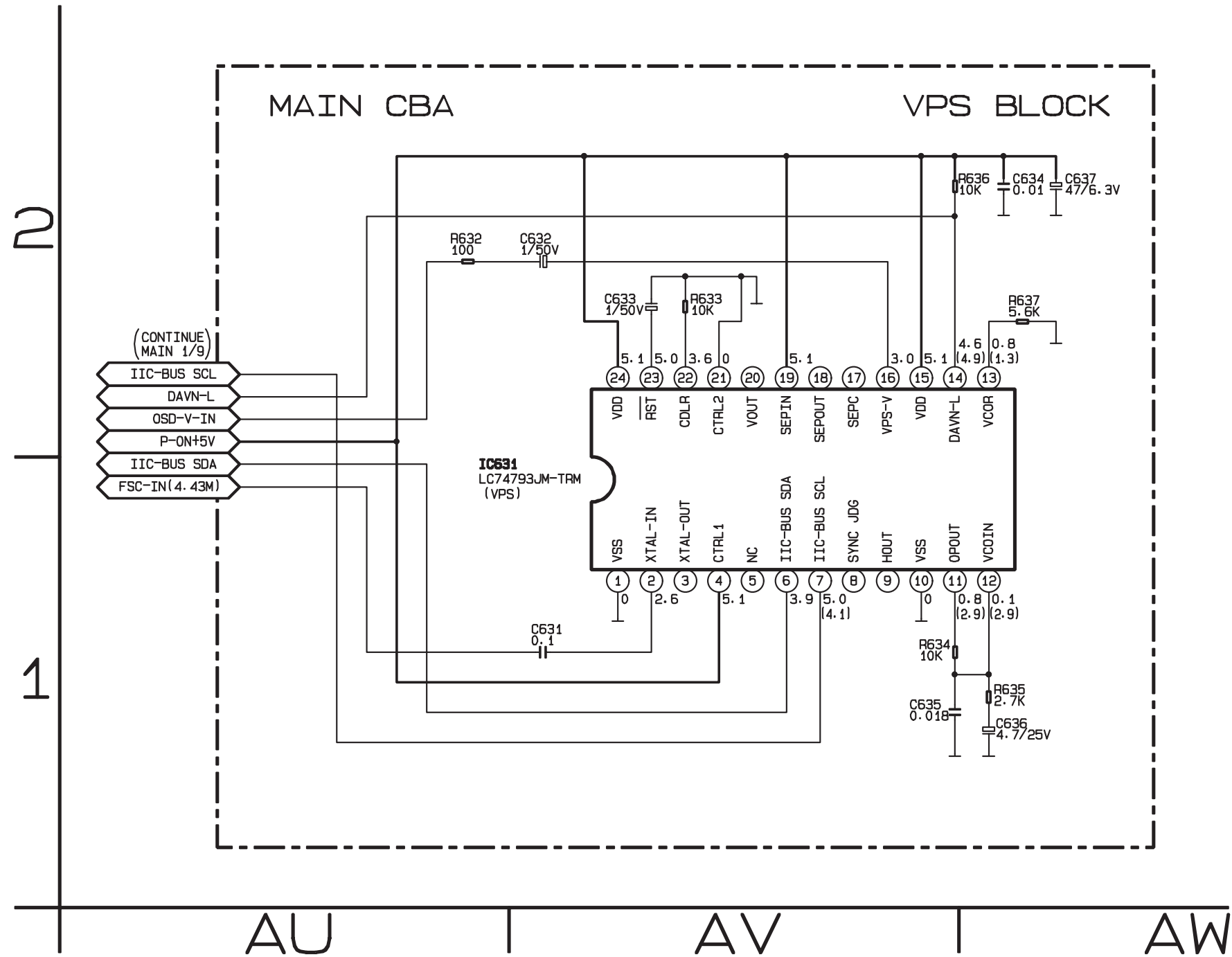

S-13 Power Supply & Junction Schematic Diagrams

CAUTION !
For continued protection against fire hazard, replace only with the same type fuse.

NOTE :
The voltage for parts in hot circuit is measured using hot GND as a common terminal.

CAUTION !
Fixed voltage (or Auto voltage selectable) power supply circuit is used in this unit. If Main Fuse (F1001) is blown, check to see that all components in the power supply circuit are not defective before you connect the AC plug to the AC power supply. Otherwise it may cause some components in the power supply circuit to fail.

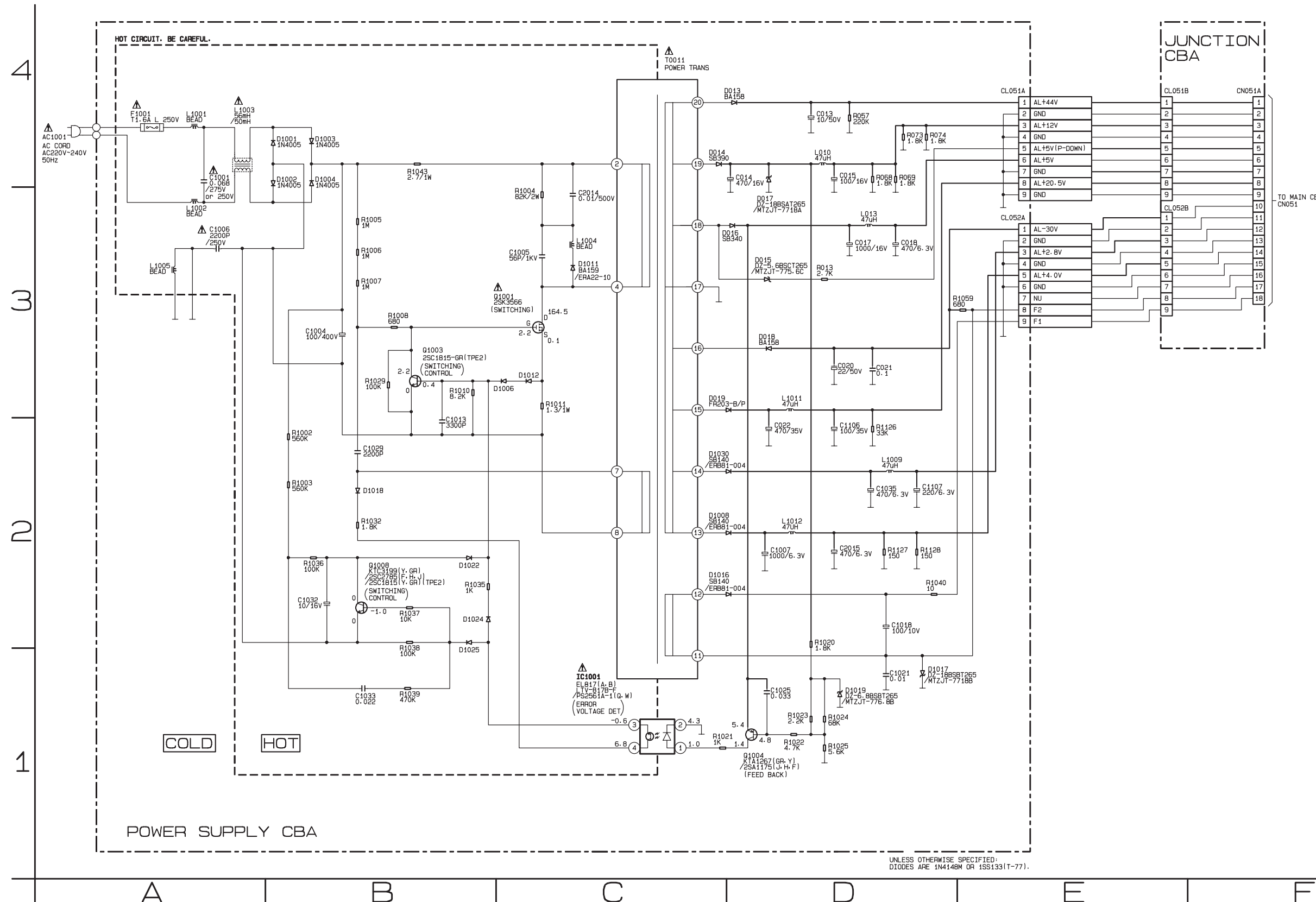

S-14 Jack-A Schematic Diagram

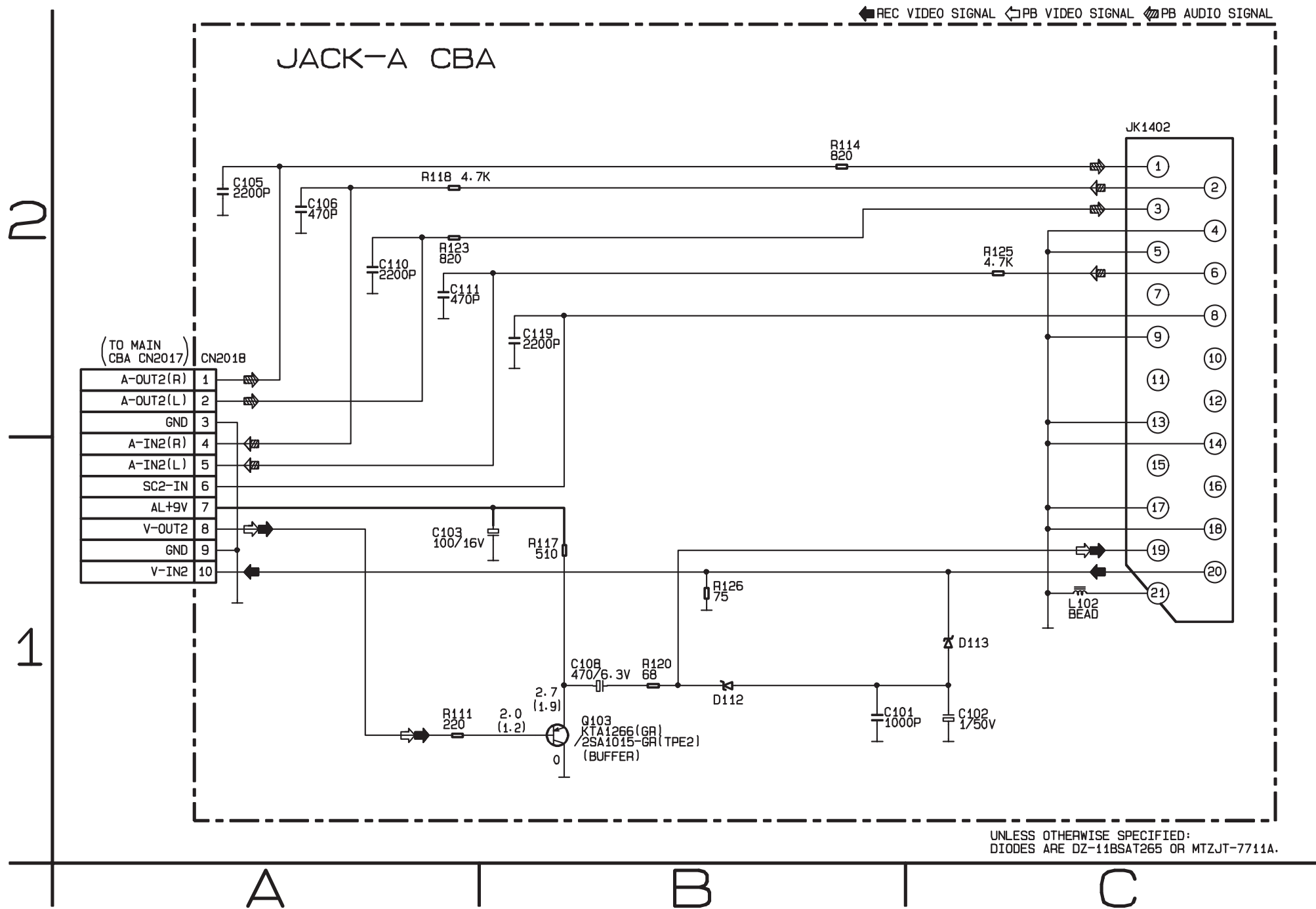

S-15 AFV Schematic Diagram

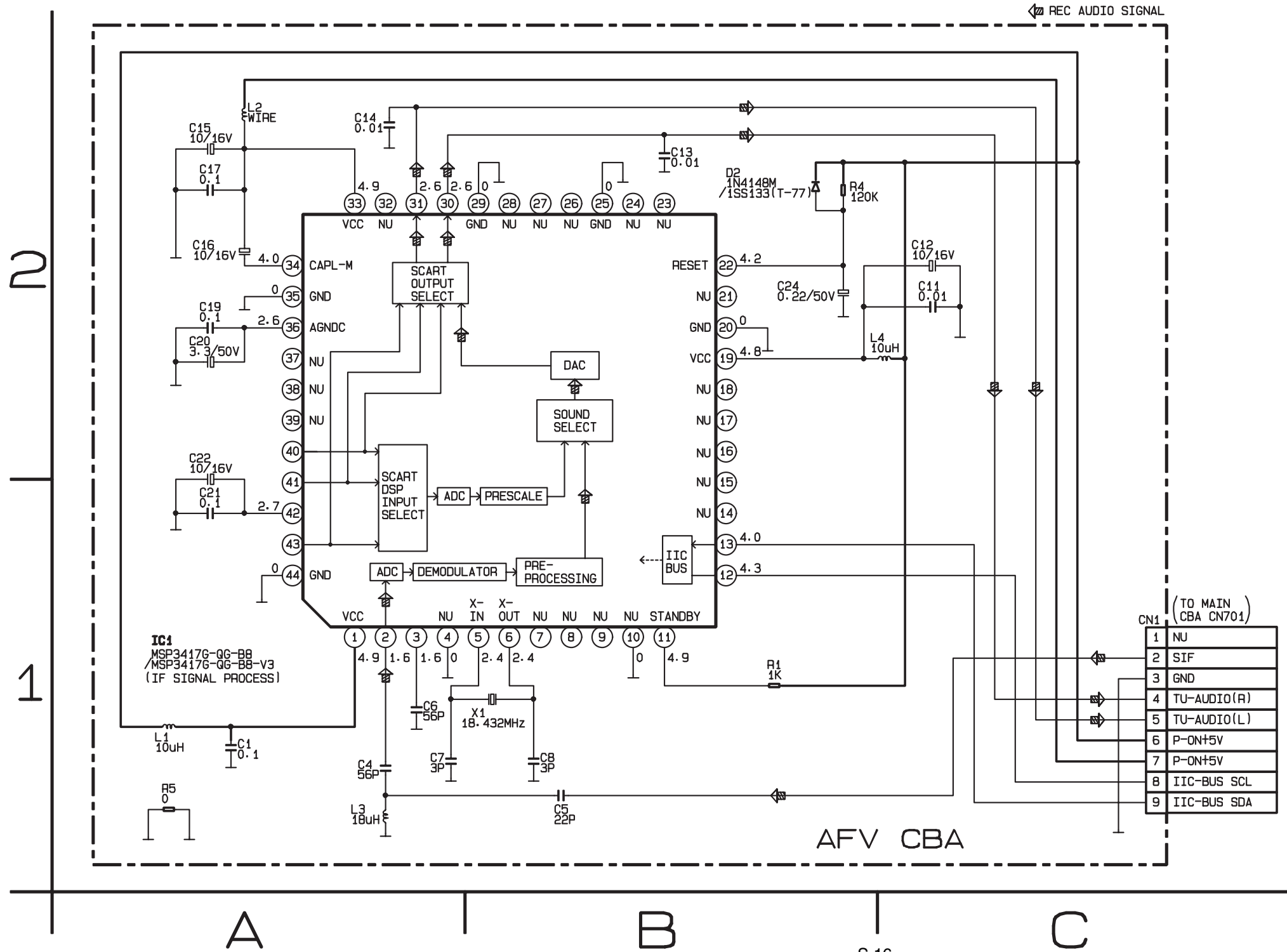

S-16 DVD Main 1/3 Schematic Diagram

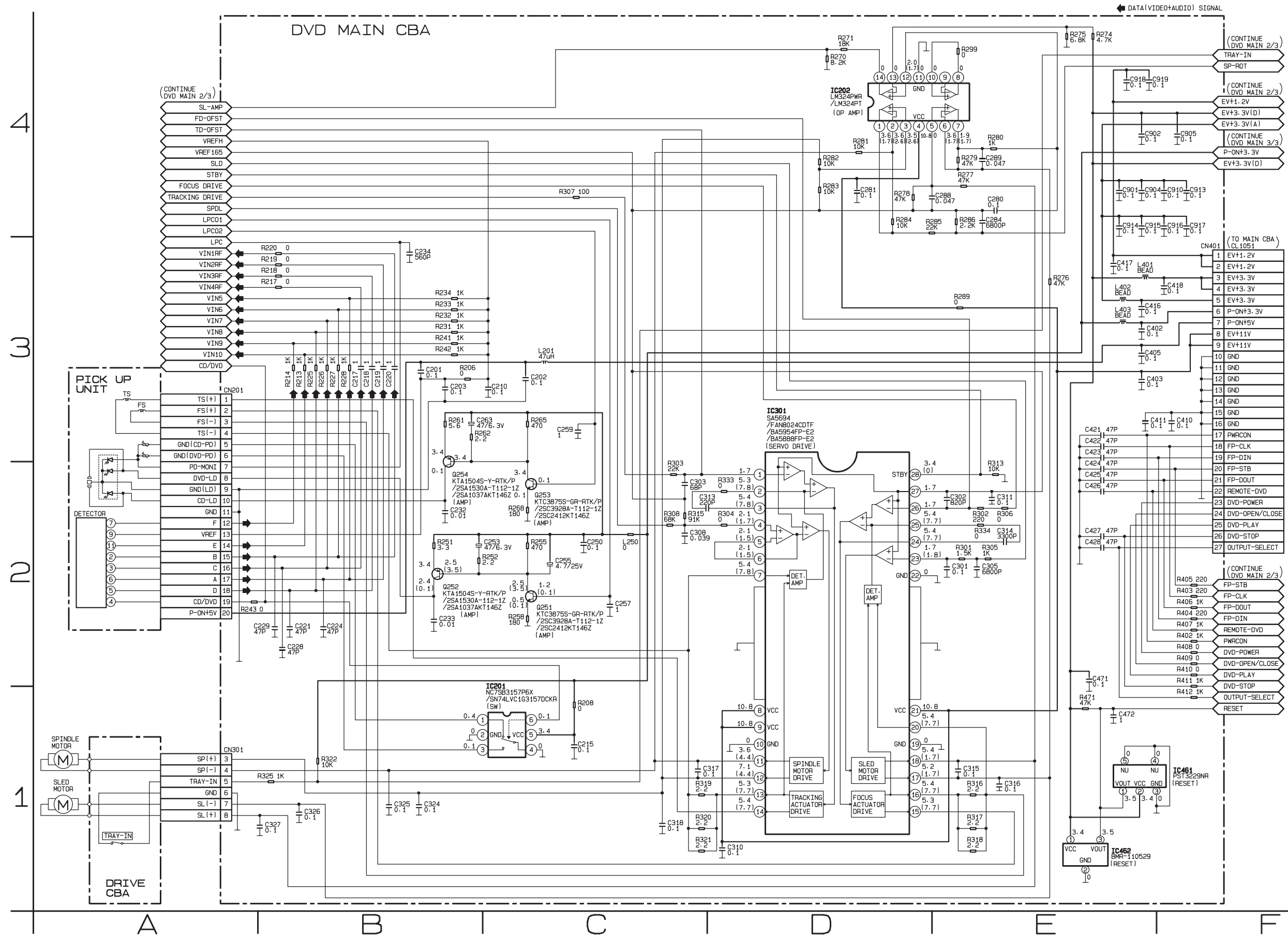

S-17 DVD Main 2/3 Schematic Diagram

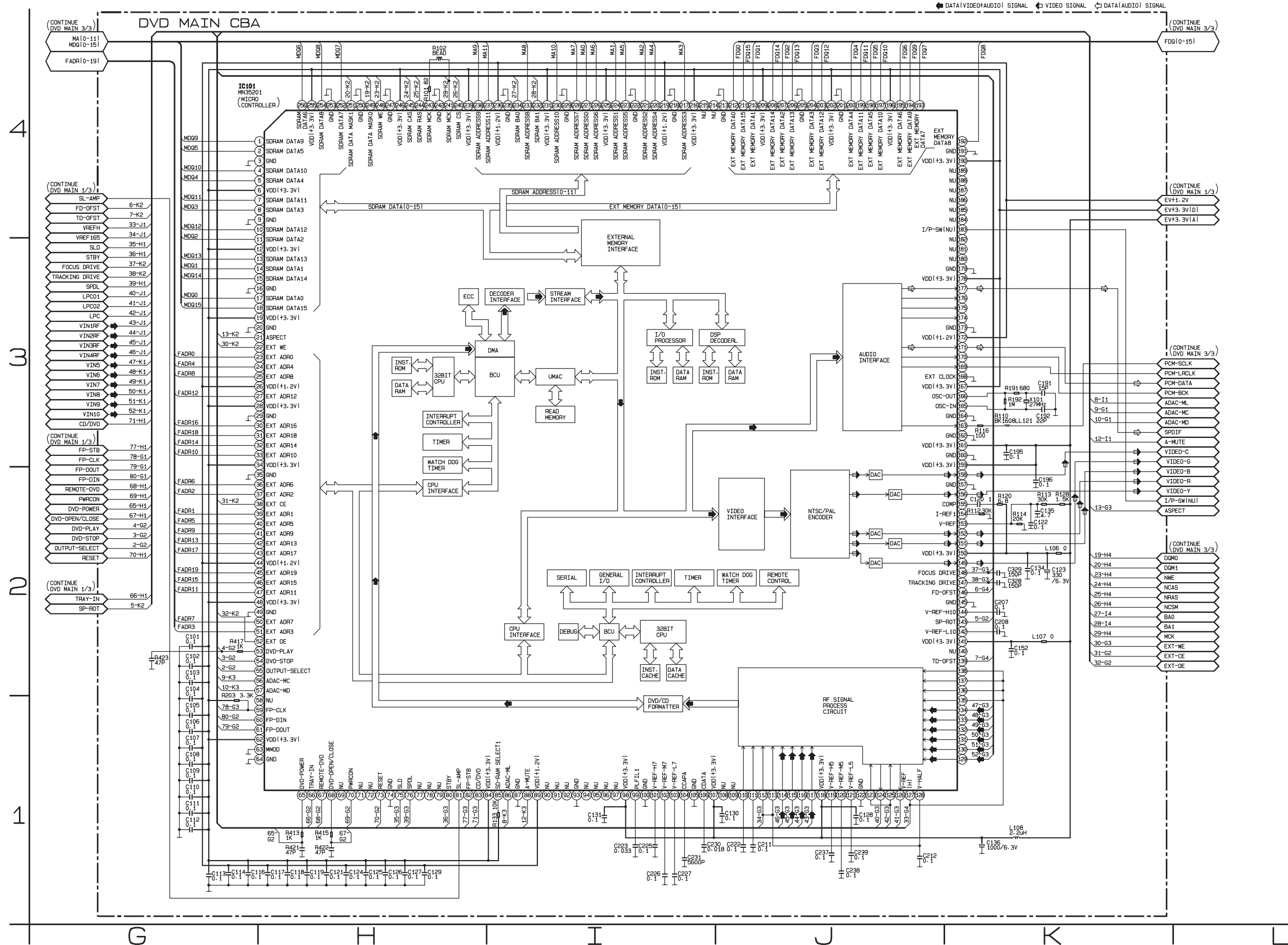

S-18 IC101 Voltage Chart

PIN.NO	PLAY	STOP	PIN.NO	PLAY	STOP	PIN.NO	PLAY	STOP	PIN.NO	PLAY	STOP	PIN.NO	PLAY	STOP	PIN.NO	PLAY	STOP	PIN.NO	PLAY	STOP	PIN.NO	PLAY	STOP
1	~	~	33	~	~	65	0	0	97	----	----	129	2.3	2.3	161	3.4	3.4	193	~	~	225	3.4	3.4
2	~	~	34	3.4	3.4	66	3.4	3.5	98	3.4	3.4	130	2.3	2.3	162	0	0	194	~	~	226	~	~
3	0	0	35	0	0	67	3.2	3.2	99	0.9	0.8	131	2.3	2.3	163	1.8	1.8	195	~	~	227	~	~
4	~	~	36	~	~	68	0	0	100	0	0	132	2.4	2.3	164	0	0	196	3.4	3.4	228	~	~
5	~	~	37	~	~	69	----	----	101	2.4	2.4	133	2.4	2.4	165	1.7	1.8	197	~	~	229	0	0
6	3.4	3.4	38	0.4	0.3	70	3.4	3.4	102	2.2	2.2	134	2.4	2.4	166	1.7	1.7	198	~	~	230	~	~
7	~	~	39	~	~	71	----	----	103	1.9	1.9	135	2.3	2.3	167	3.4	3.4	199	~	~	231	3.4	3.4
8	~	~	40	~	~	72	----	----	104	0.4	0.3	136	2.3	2.3	168	0	0	200	~	~	232	1.3	1.6
9	0	0	41	~	~	73	3.4	3.4	105	0	0	137	2.3	2.3	169	1.8	1.8	201	0	0	233	~	~
10	~	~	42	~	~	74	0	0	106	1.7	1.7	138	2.3	2.3	170	1.7	1.7	202	3.4	3.4	234	1.9	2.3
11	~	~	43	~	~	75	1.7	1.8	107	3.4	3.4	139	1.7	1.7	171	1.3	0.1	203	~	~	235	0	0
12	3.4	3.4	44	1.3	1.3	76	2.3	1.8	108	----	----	140	----	----	172	1.3	1.3	204	~	~	236	1.3	1.3
13	~	~	45	~	~	77	----	----	109	----	----	141	3.4	3.4	173	0	0	205	0	0	237	~	~
14	~	~	46	~	~	78	----	----	110	1.9	1.9	142	1.3	1.3	174	----	----	206	~	~	238	~	~
15	~	~	47	~	~	79	----	----	111	1.9	1.9	143	2.1	1.7	175	----	----	207	~	~	239	3.4	3.4
16	0	0	48	3.4	3.4	80	3.4	0.1	112	1.7	1.7	144	2.2	2.2	176	----	----	208	~	~	240	3.4	3.3
17	~	~	49	0	0	81	0.1	0.1	113	1.7	1.7	145	0	0	177	1.8	1.7	209	3.4	3.4	241	1.9	1.9
18	~	~	50	~	~	82	2.8	2.8	114	1.7	1.7	146	1.7	1.7	178	3.4	3.5	210	~	~	242	0	0
19	3.4	3.4	51	~	~	83	0.1	0.1	115	1.7	1.7	147	1.8	1.7	179	0	0	211	~	~	243	1.9	1.9
20	0	0	52	0.8	0.8	84	3.4	3.4	116	1.7	1.7	148	1.7	1.7	180	----	----	212	~	~	244	3.4	3.3
21	----	----	53	0	0	85	0.1	0.1	117	1.7	1.7	149	0.6	0.5	181	----	----	213	0	0	245	3.4	3.4
22	3.5	3.5	54	0	0	86	3.6	3.4	118	3.4	3.4	150	3.4	3.4	182	----	----	214	----	----	246	3.4	3.4
23	~	~	55	1.4	1.4	87	0	0	119	2.0	2.0	151	0.5	0.6	183	3.5	3.5	215	----	----	247	0	0
24	~	~	56	3.4	3.4	88	3.5	0.1	120	1.7	1.7	152	0.5	0.4	184	----	----	216	3.4	3.4	248	3.3	3.4
25	~	~	57	3.5	3.5	89	1.3	1.3	121	1.5	1.5	153	1.4	1.3	185	----	----	217	~	~	249	3.2	3
26	1.3	1.3	58	----	----	90	----	----	122	0	0	154	1.4	1.3	186	----	----	218	0	0	250	0	0
27	~	~	59	3.4	3.4	91	----	----	123	0.3	0.1	155	2.4	2.4	187	----	----	219	1.3	1.3	251	3.2	3.0
28	3.4	3.4	60	3.4	3.4	92	----	----	124	1.2	0.1	156	3.4	3.4	188	----	----	220	~	~	252	~	~
29	0	0	61	3.5	3.5	93	0	0	125	0.3	0.1	157	0	0	189	----	----	221	~	~	253	0	0
30	~	~	62	3.4	3.4	94	----	----	126	0.1	0.1	158	0.9	0.9	190	3.4	3.5	222	0	0	254	~	~
31	~	~	63	0	0	95	----	----	127	2.3	2.3	159	3.4	3.4	191	0	0	223	~	~	255	3.4	3.4
32	~	~	64	0	0	96	----	----	128	1.7	1.7	160	0	0	192	~	~	224	~	~	256	~	~

S-19 DVD Main 3/3 Schematic Diagram

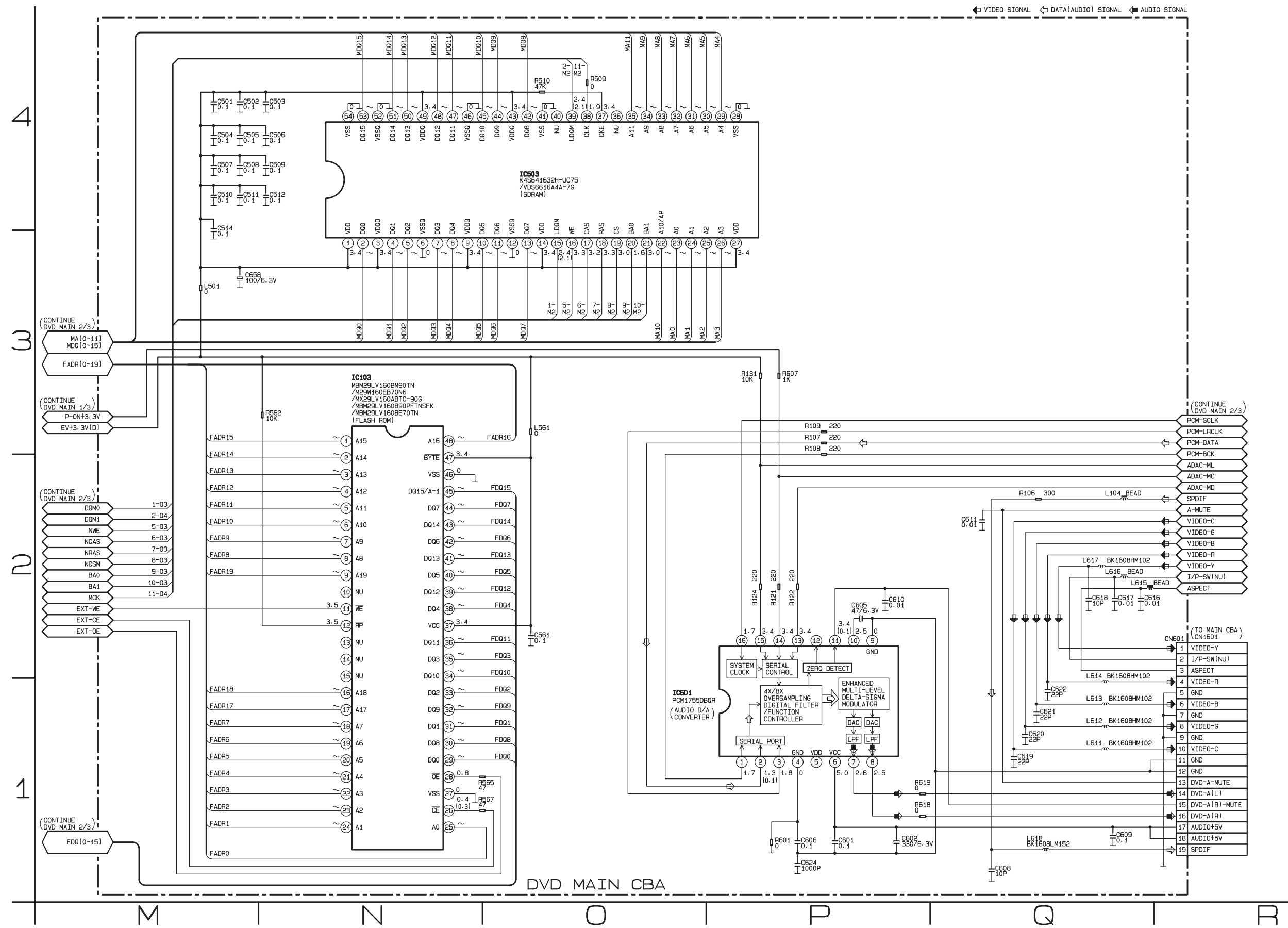

S-20 Waveforms

NOTE:

Input

VCR: COLOR BAR SIGNAL
(WF1~WF3)

DVD: POWER ON (STOP) MODE
(WF4~WF6)

CD: 1kHz PLAY
(WF7~WF9)

WF2 UPPER TP301

WF1 LOWER TP504

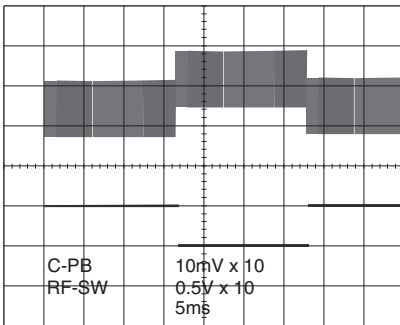

WF4 Pin 1 of CN1601

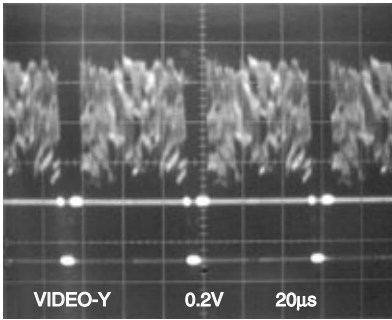

WF7 Pin 14 of CN1601

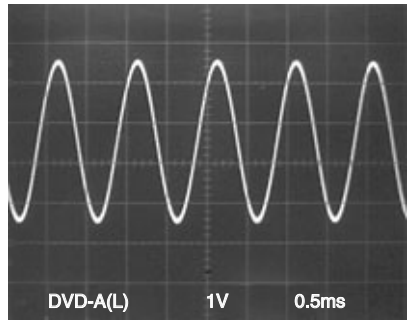

WF3 UPPER TP751

WF1 LOWER TP504

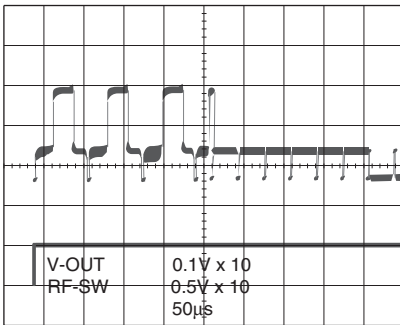

WF5 Pin 10 of CN1601

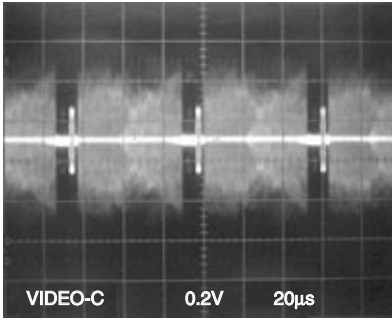

WF8 Pin 16 of CN1601

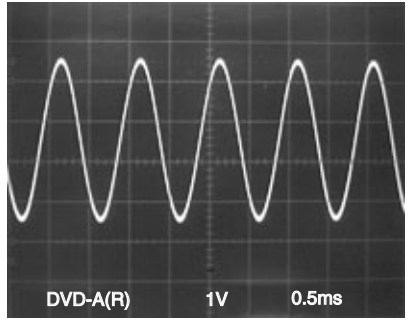

WF3 TP751

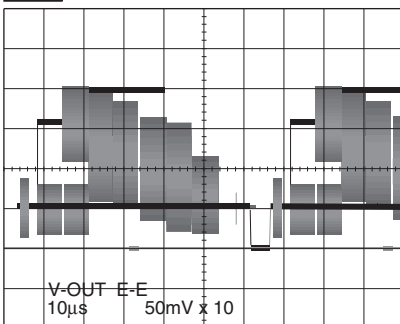

WF6 Pin 6 of IC1403

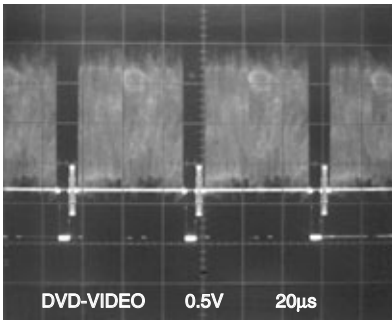

WF9 Pin 19 of CN1601

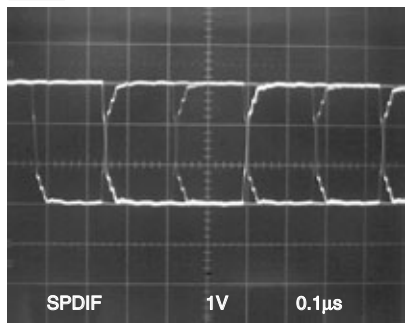

C CIRCUIT BOARD DIAGRAMS

C-1 Main CBA Top View & Sensor CBA Top View

Sensor CBA Top View

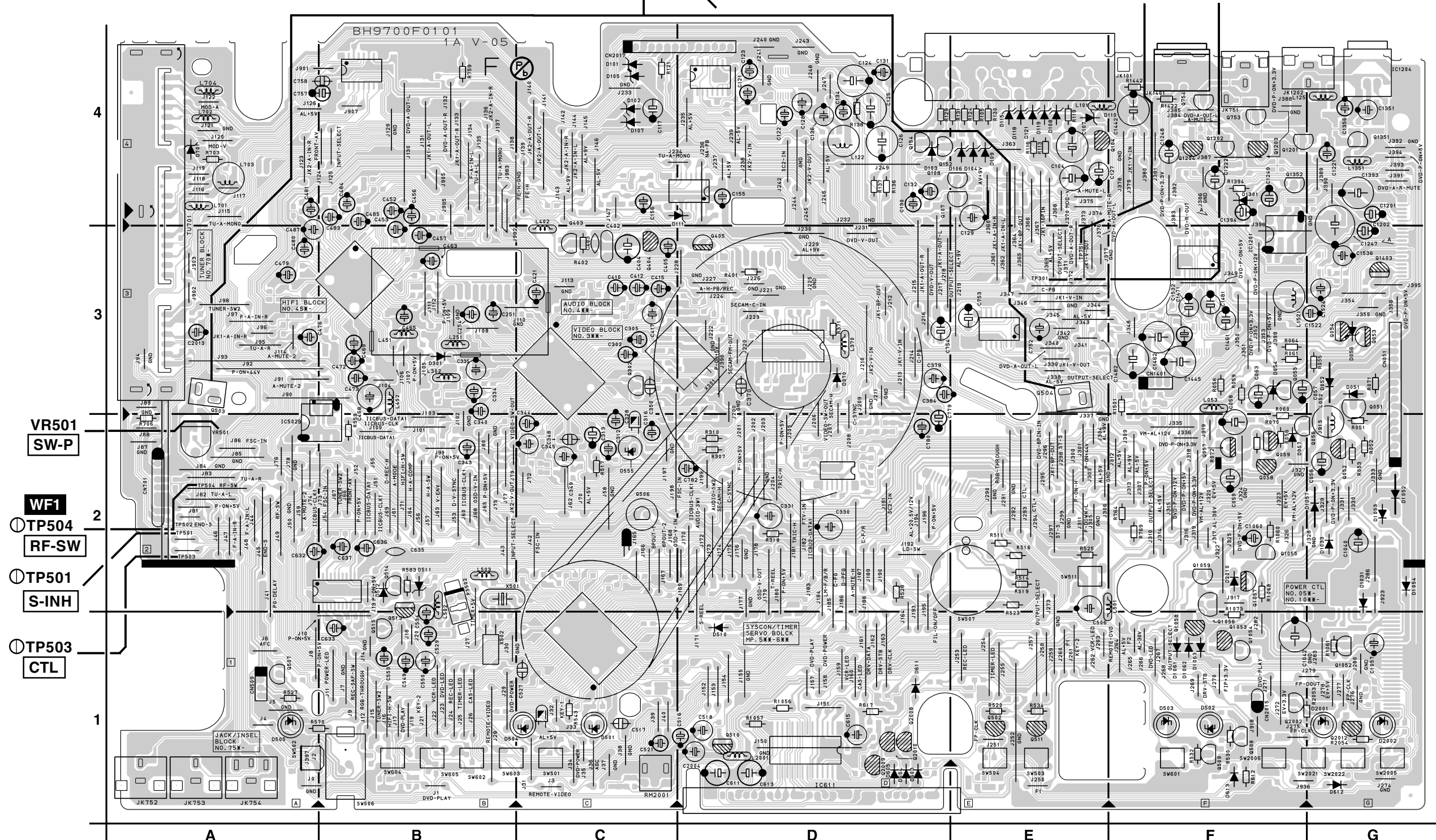
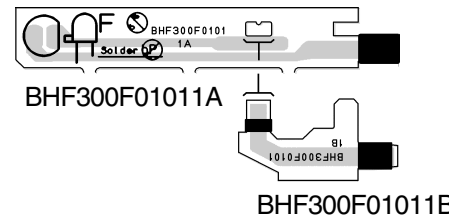

C-2 Main CBA Bottom View

- WF6**
PIN 6 OF
IC1403
- WF9**
PIN 19 OF
CN1601
- WF8**
PIN 16 OF
CN1601
- WF7**
PIN 14 OF
CN1601
- WF5**
PIN 10 OF
CN1601
- WF4**
PIN 1 OF
CN1601

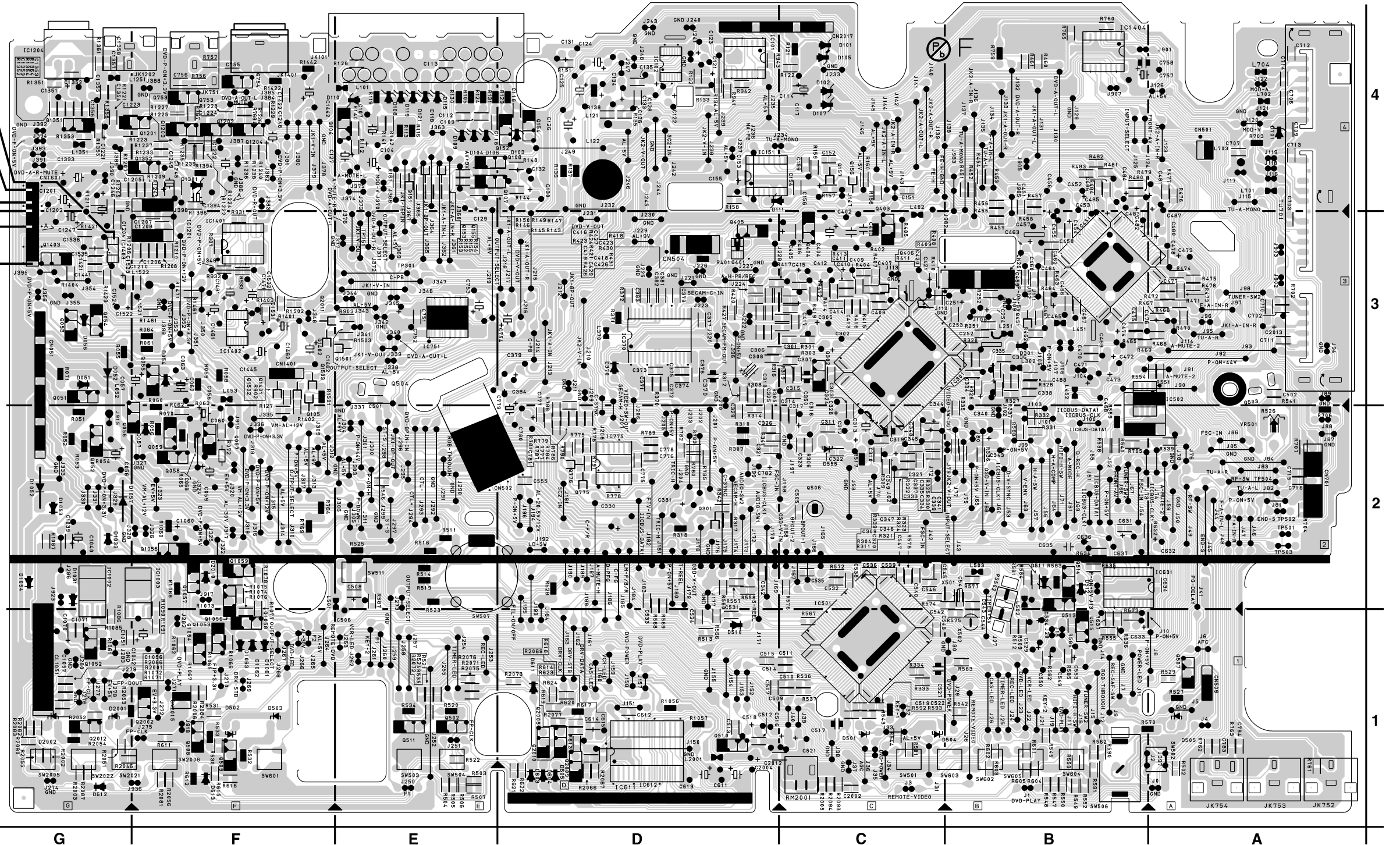

C-3 Power SW CBA Top/Bottom View & DVD Open/Close CBA Top/Bottom View

Power SW CBA Top View

Power SW CBA Bottom View

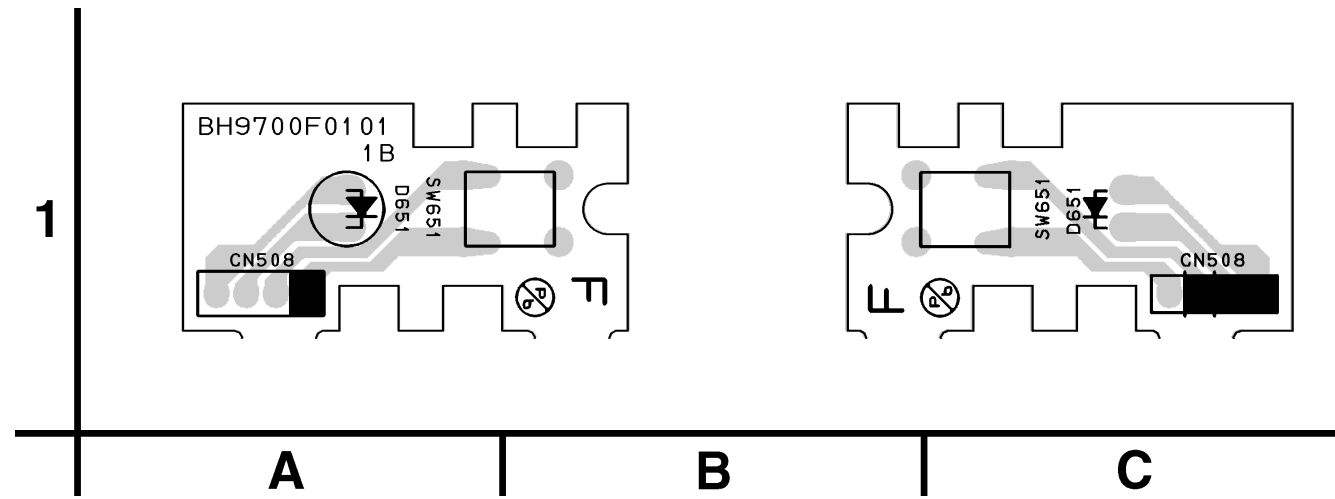

DVD Open/Close
CBA Top View

DVD Open/Close
CBA Bottom View

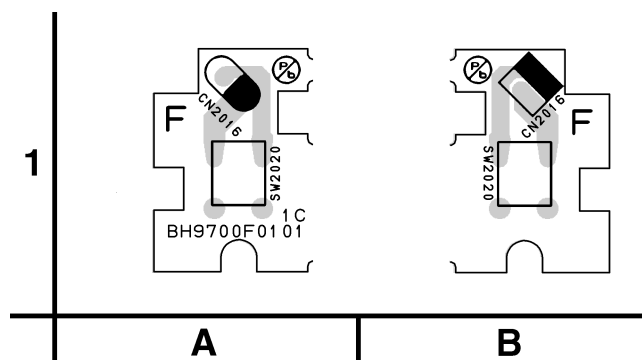

C-4 Power Supply CBA Top/Bottom View & Junction CBA Top/Bottom View

Power Supply CBA Top View

CAUTION !

For continued protection against fire hazard, replace only with the same type fuse.

NOTE :

The voltage for parts in hot circuit is measured using hot GND as a common terminal.

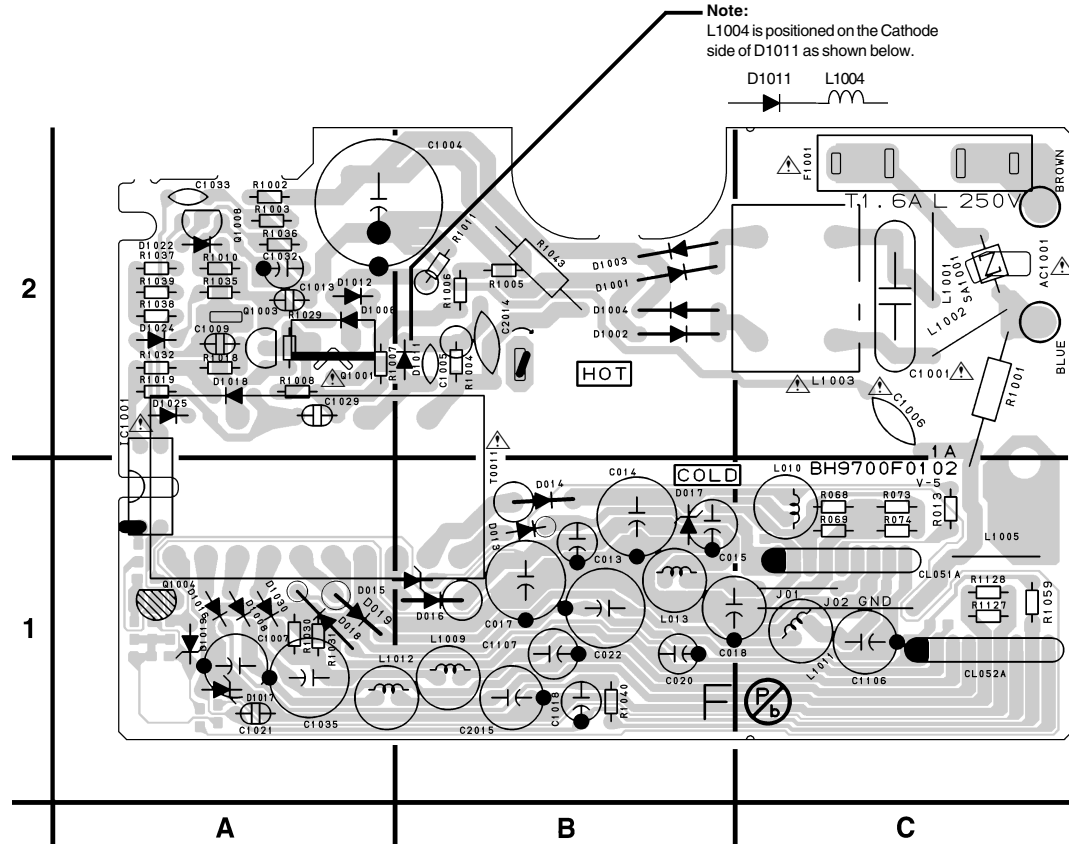

Power Supply CBA Bottom View

BECAUSE A HOT CHASSIS GROUND IS PRESENT IN THE POWER SUPPLY CIRCUIT , AN ISOLATION TRANSFORMER MUST BE USED. ALSO , IN ORDER TO HAVE THE ABILITY TO INCREASE THE INPUT SLOWLY , WHEN TROUBLESHOOTING THIS TYPE POWER SUPPLY CIRCUIT , A VARIABLE ISOLATION TRANSFORMER IS REQUIRED.

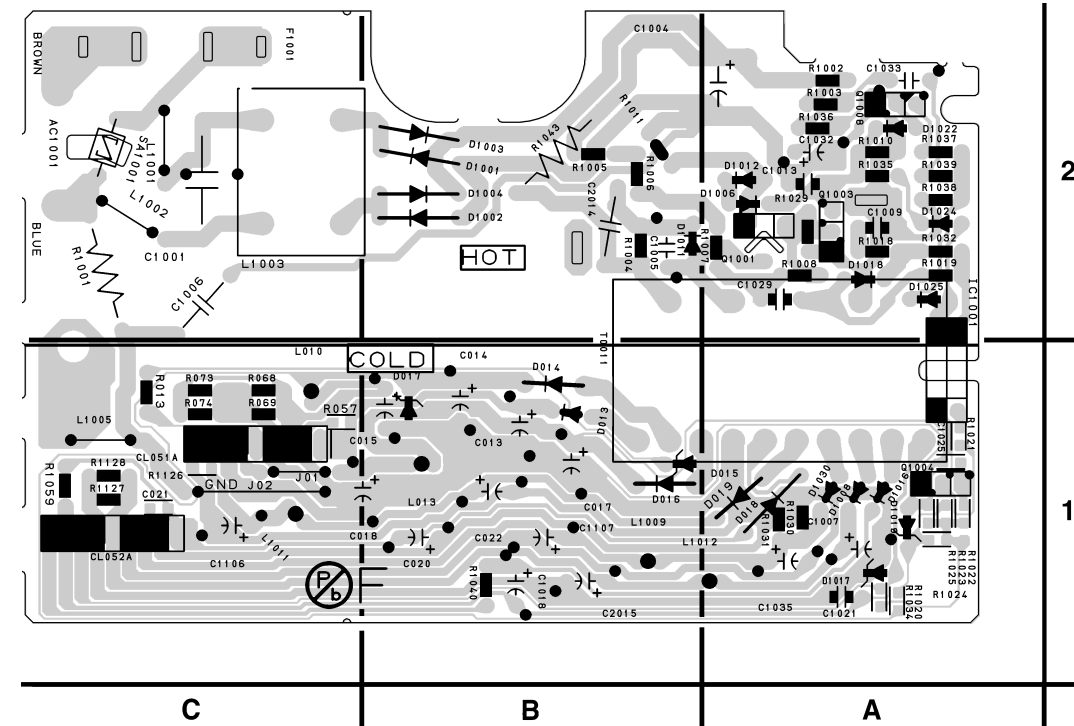

Junction CBA Top View

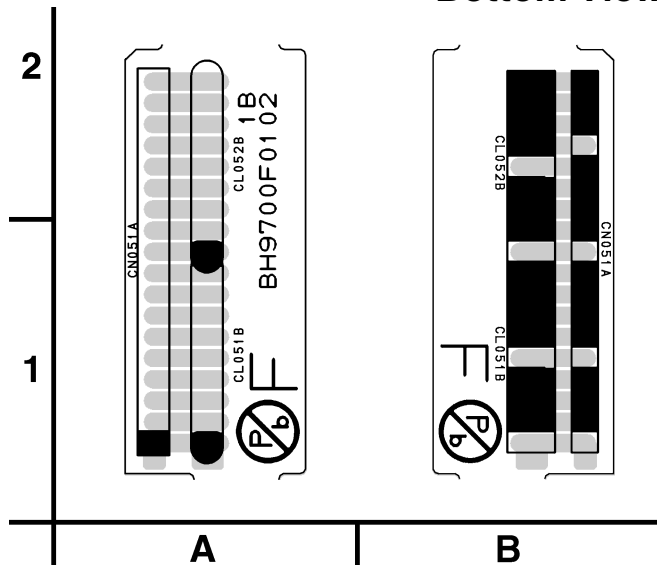

Junction CBA Bottom View

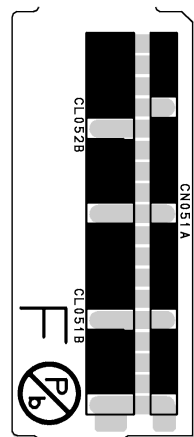

C-5 Jack-A CBA Top/Bottom View & AFV CBA Top/Bottom View

Jack-A CBA Top View

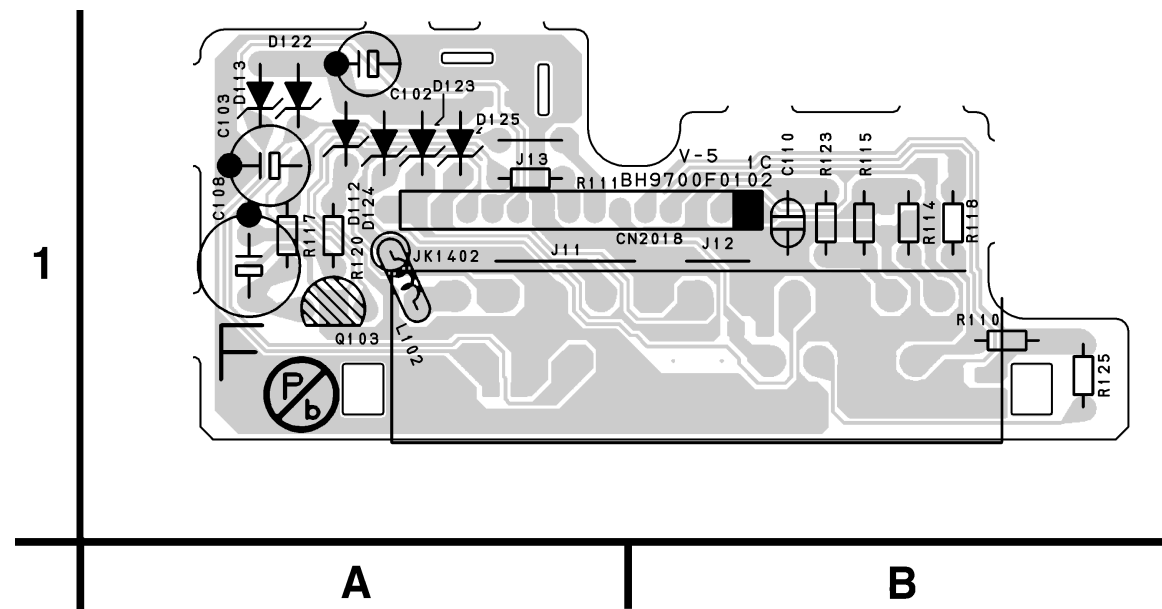

Jack-A CBA Bottom View

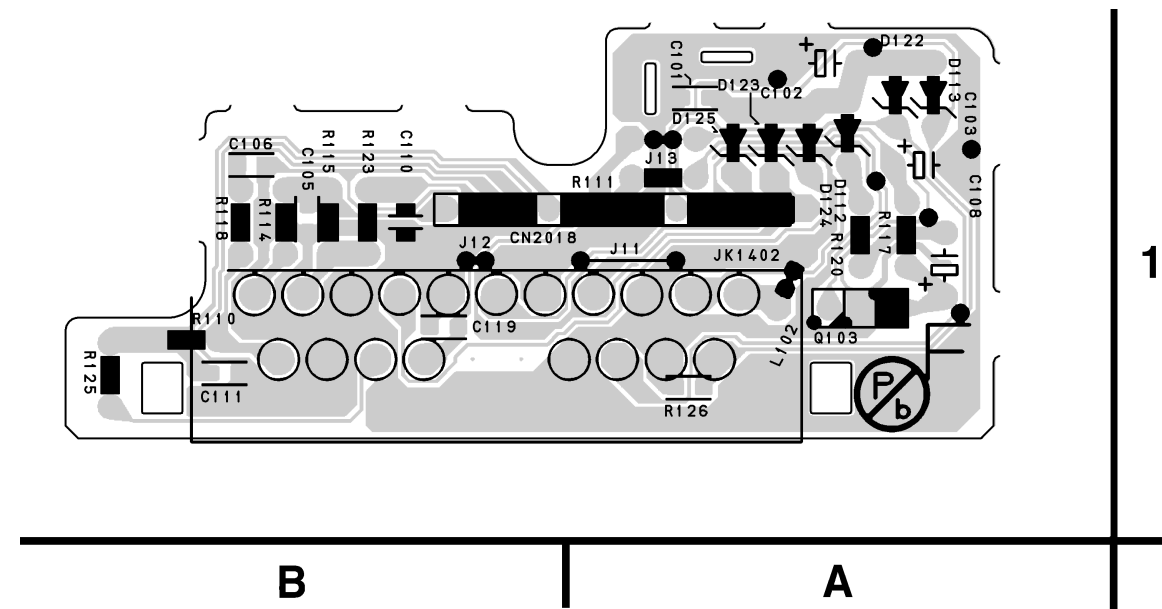

AFV CBA Top View

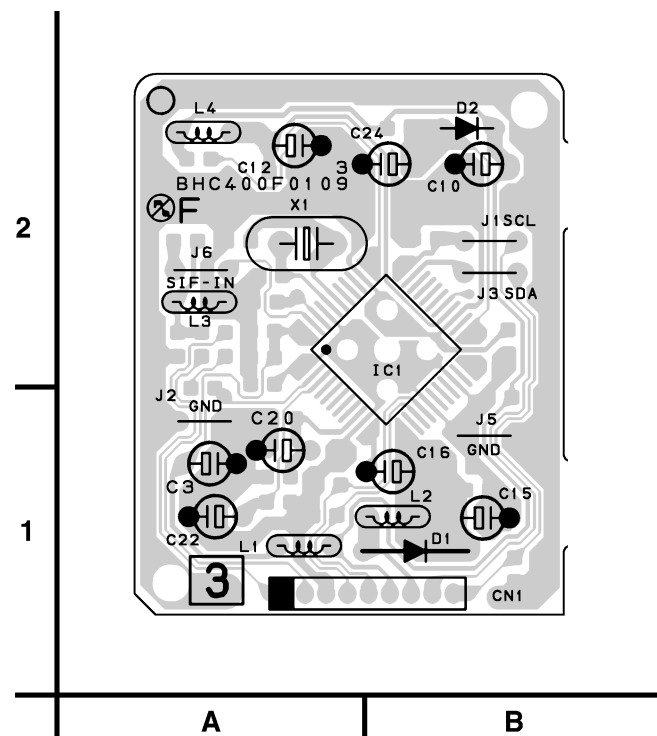

AFV CBA Bottom View

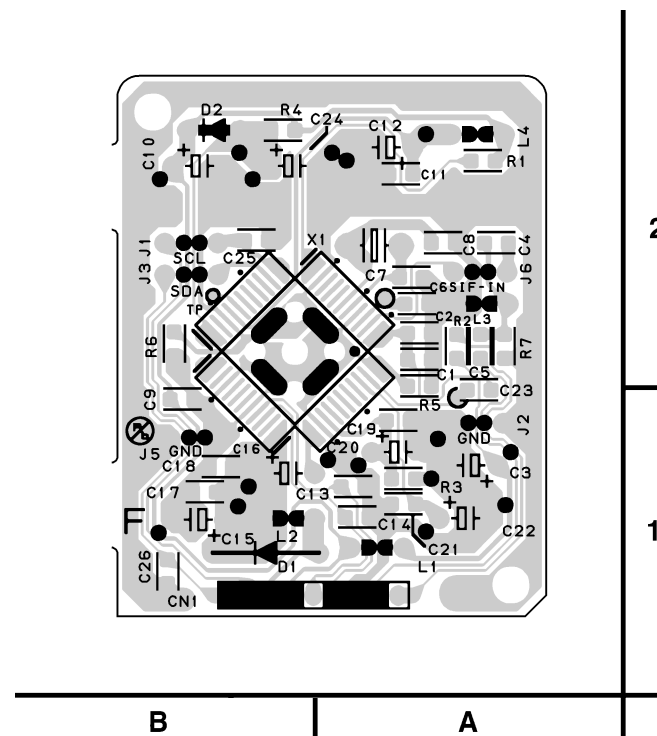

B BLOCK DIAGRAMS

B-1 Servo / System Control Block Diagram

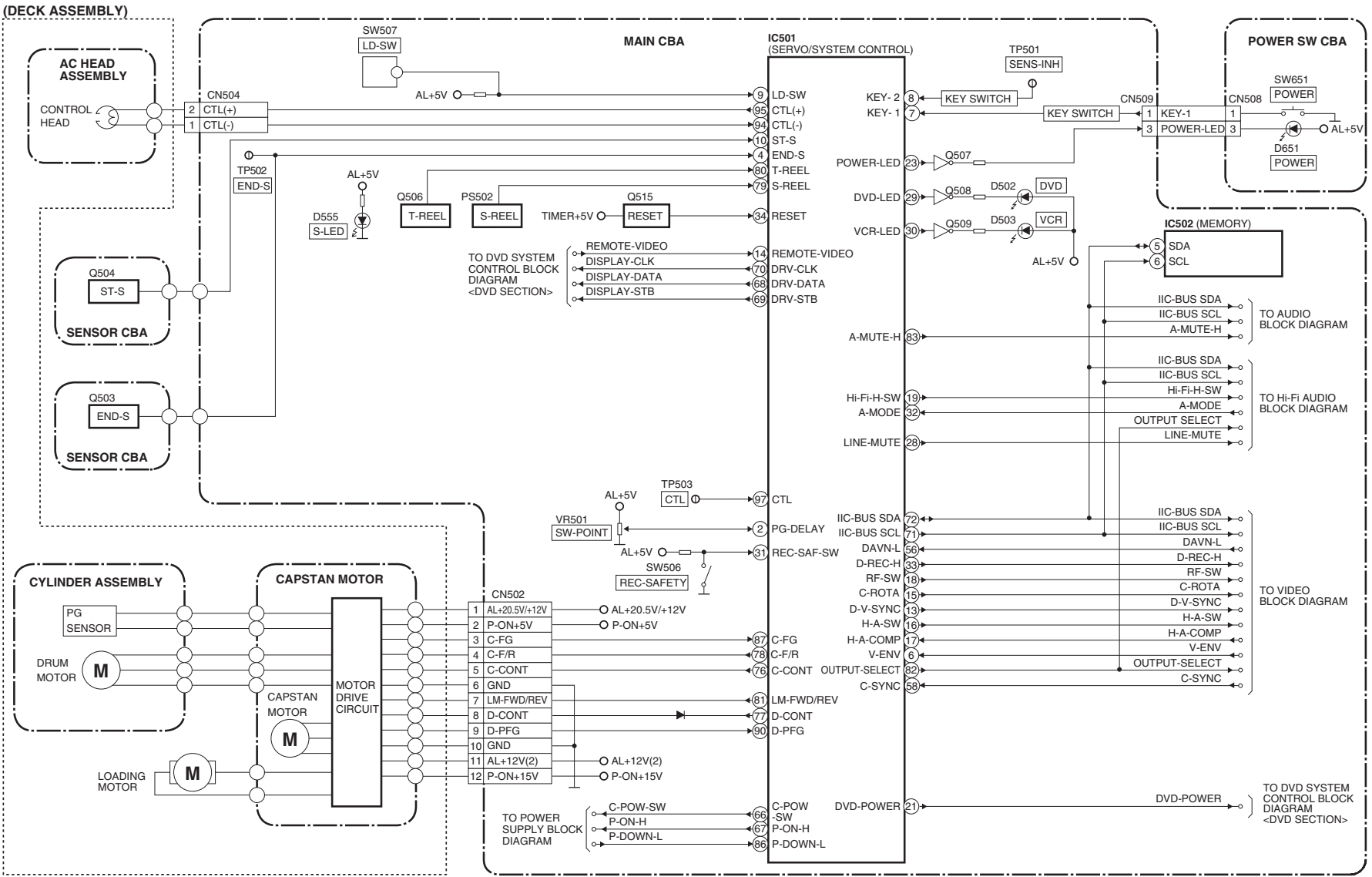

B-1

B-2 Video Block Diagram

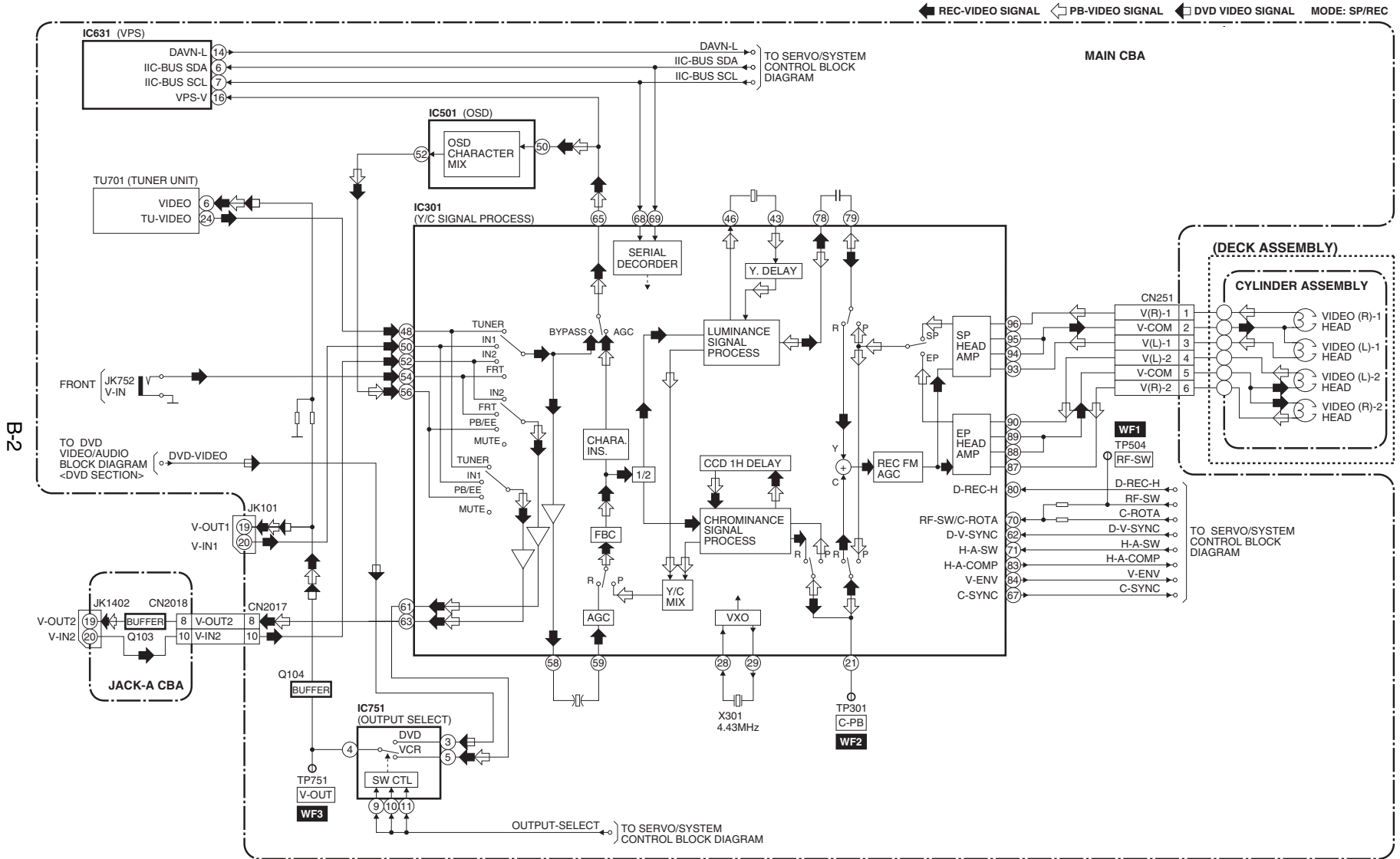

B-2

B-3 Audio Block Diagram

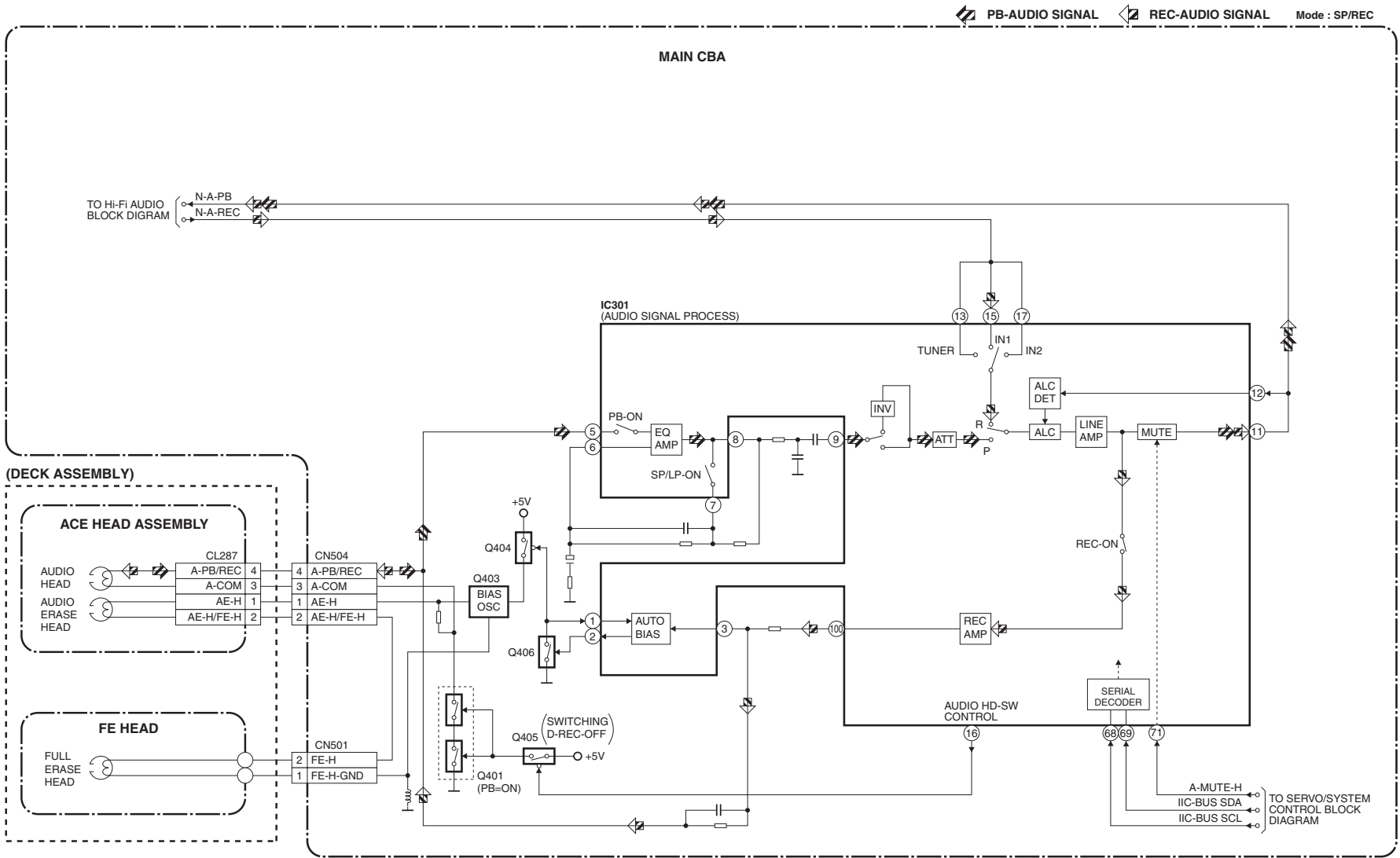

B-3

B-4 Hi-Fi Audio Block Diagram

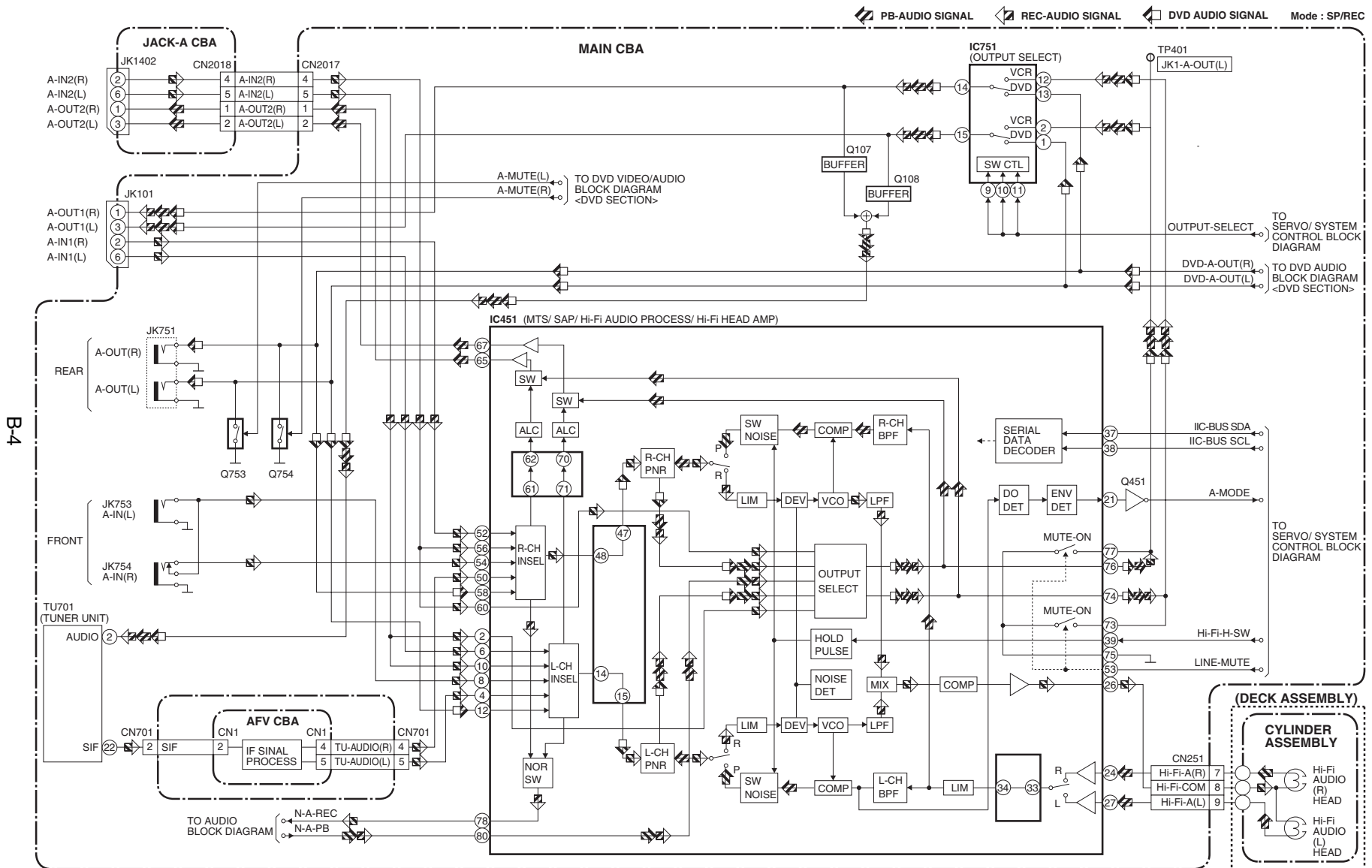

B-4

B-5 Power Supply Block Diagram

NOTE :
The voltage for parts in hot circuit is measured using hot GND as a common terminal.

CAUTION
FOR CONTINUED PROTECTION AGAINST FIRE HAZARD,
REPLACE ONLY WITH THE SAME TYPE T1.6AL/250V FUSE.

CAUTION !
Fixed voltage (or Auto voltage selectable) power supply circuit is used in this unit.
If Main Fuse (F1001) is blown, check to see that all components in the power supply circuit are not defective before you connect the AC plug to the AC power supply.
Otherwise it may cause some components in the power supply circuit to fail.

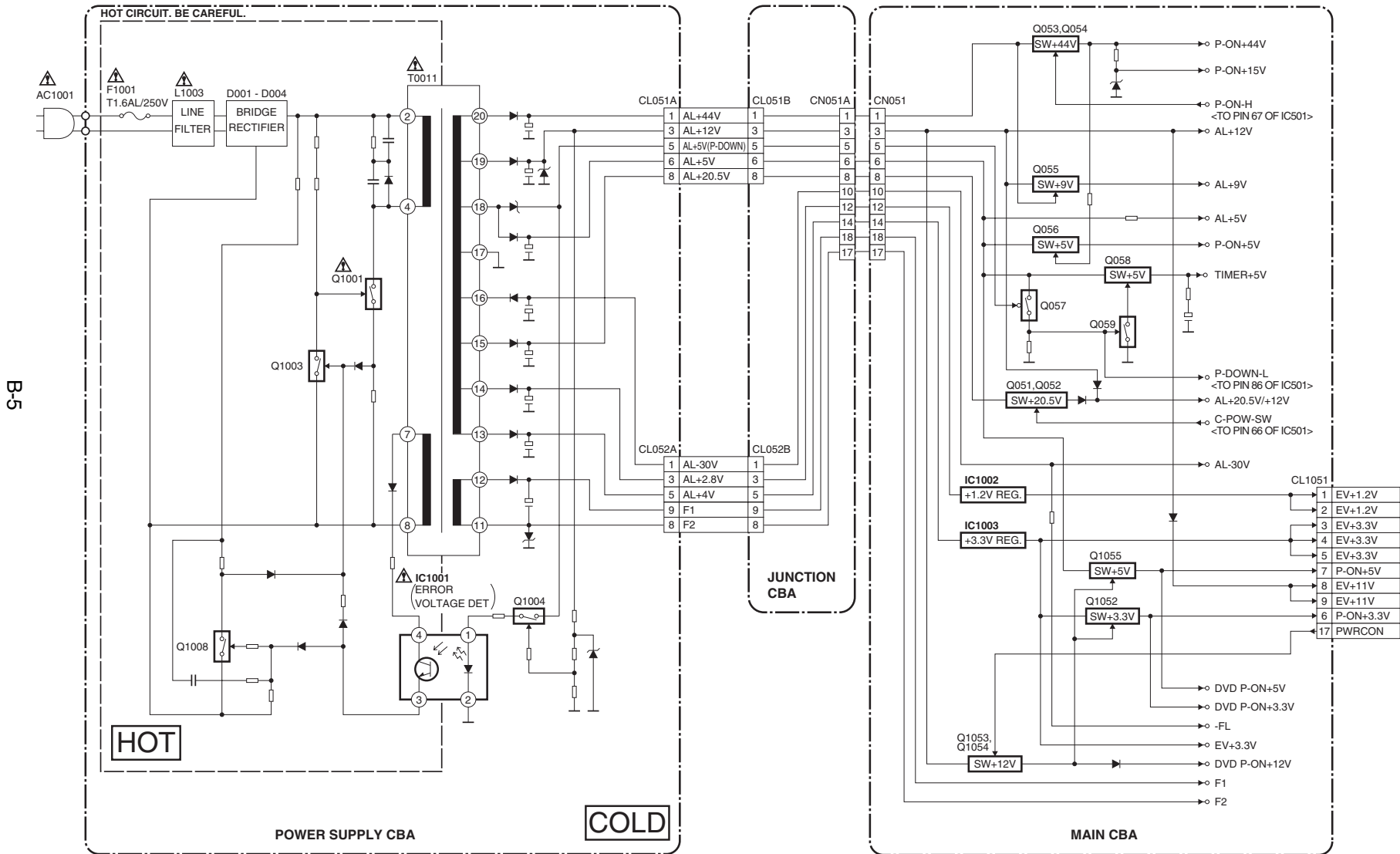

B-5

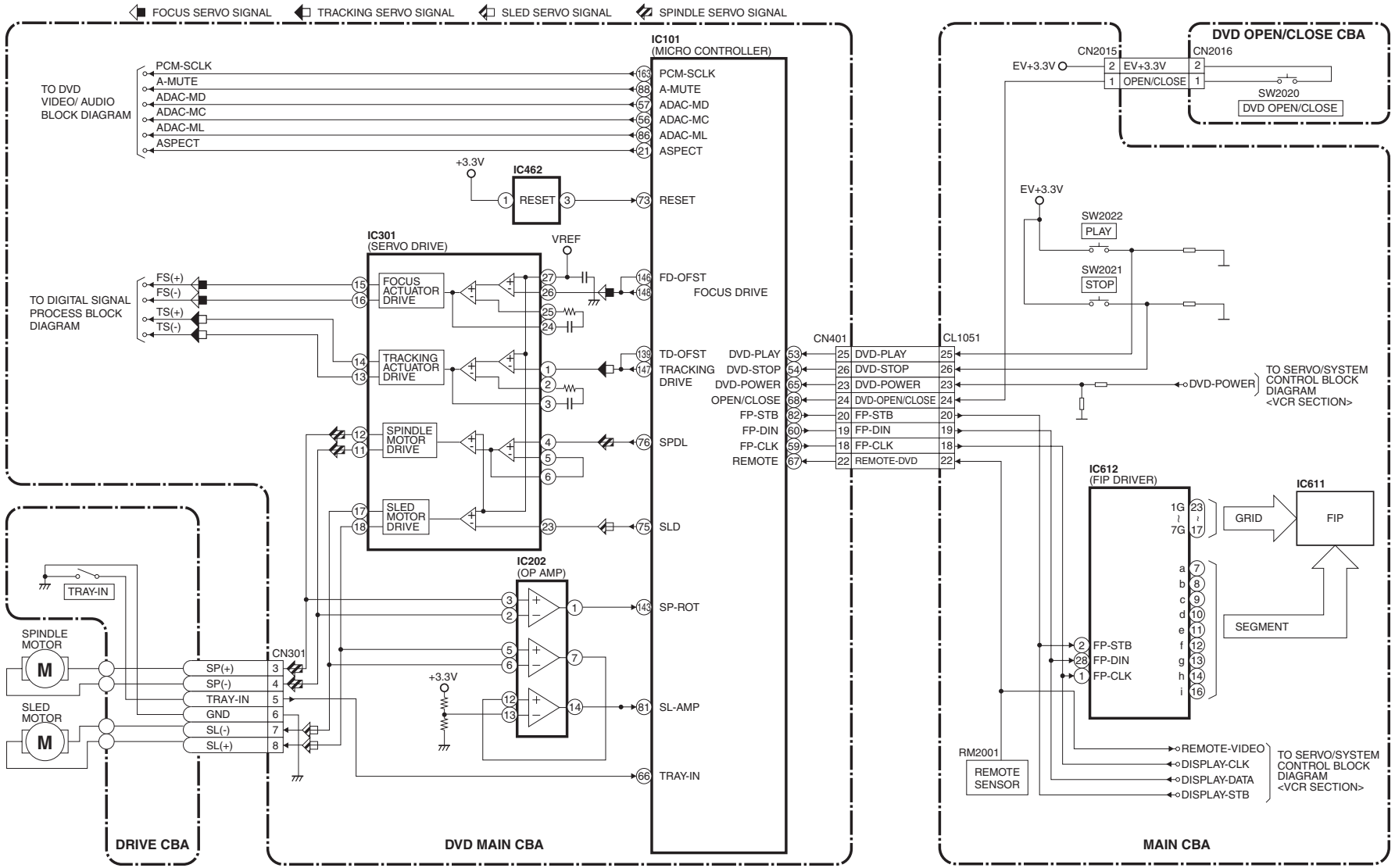

B-6 DVD System Control / Servo Block Diagram

B-7 Digital Signal Process Block Diagram

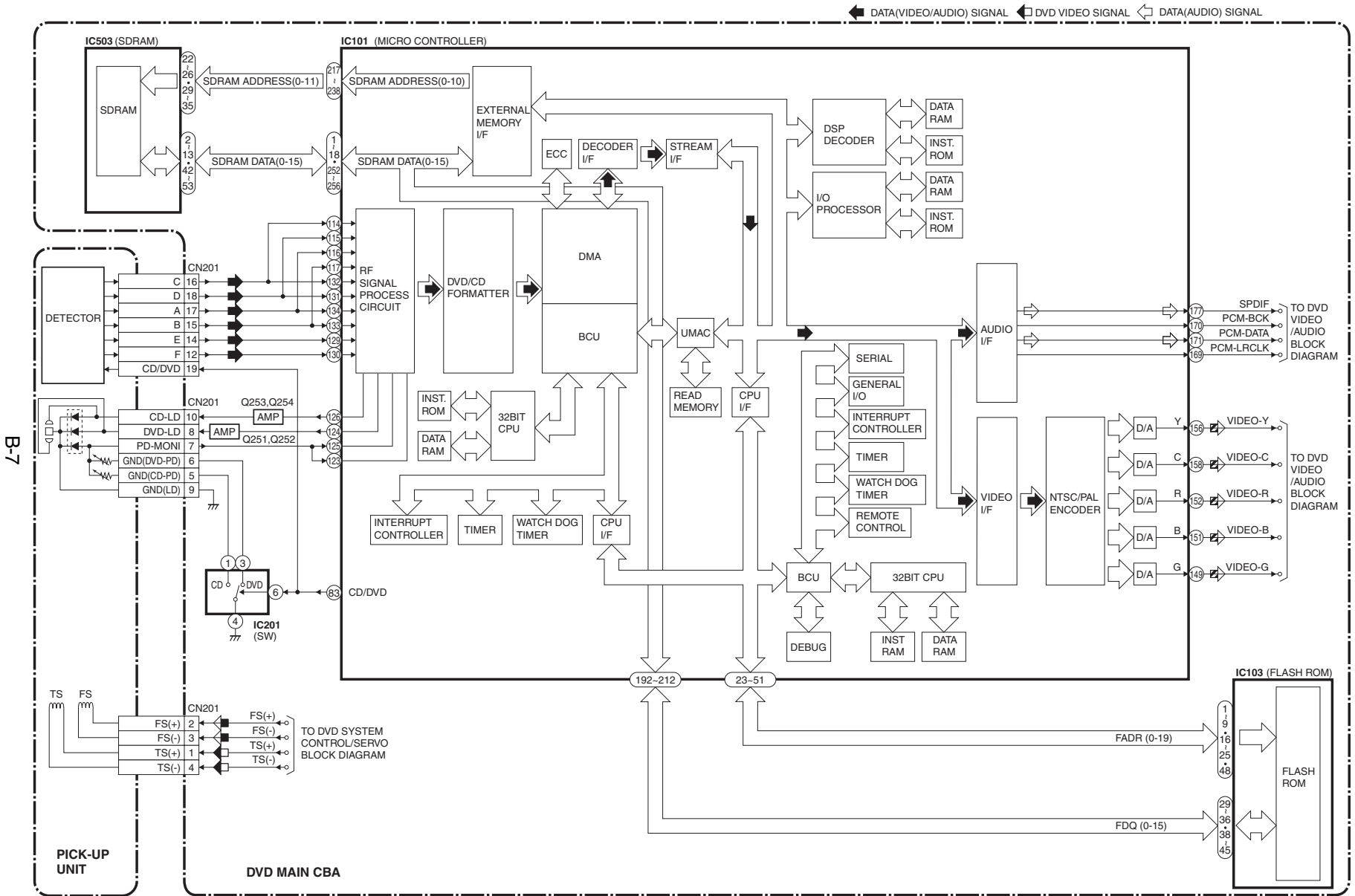

B-7

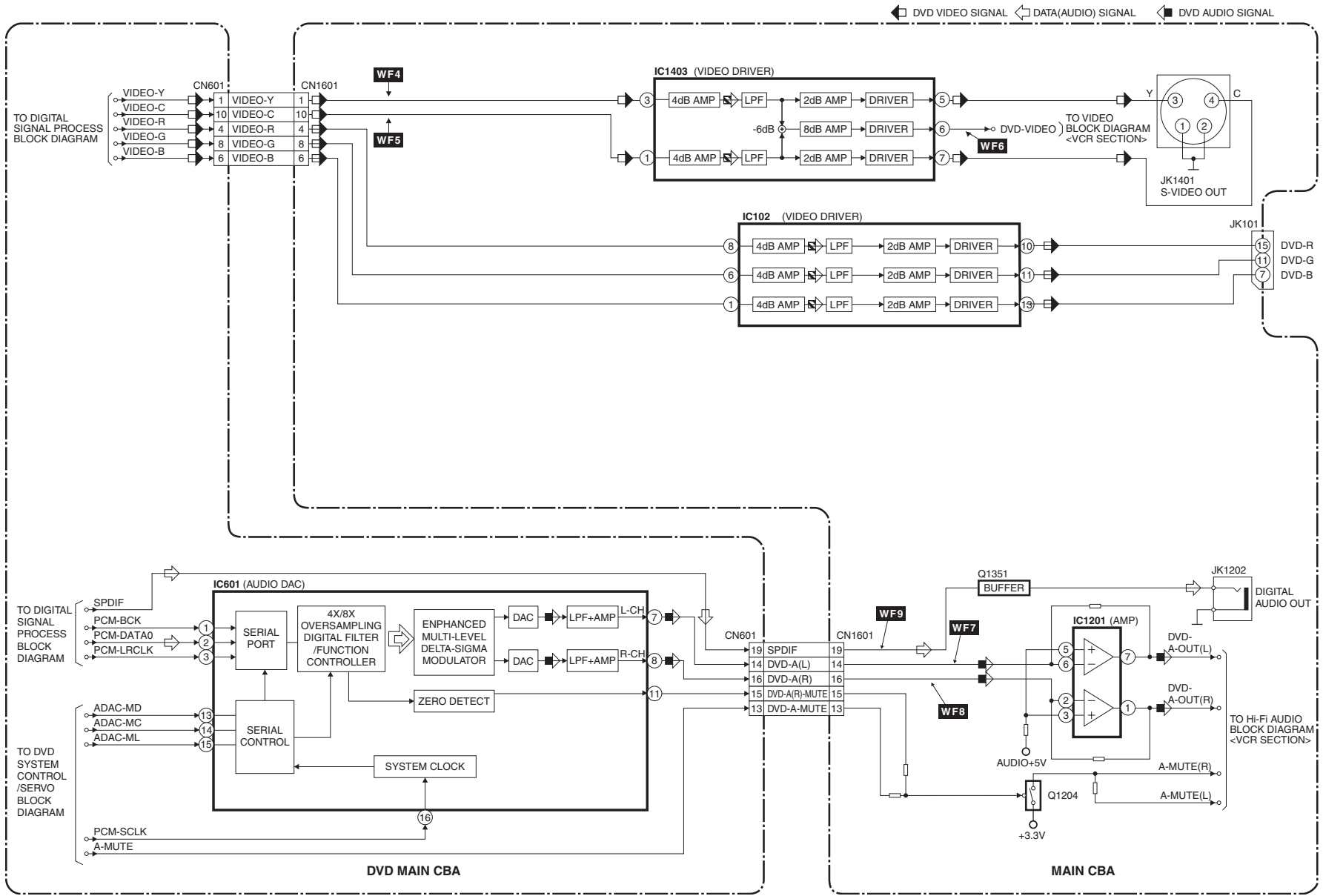

HITACHI

Hitachi, Ltd. Tokyo, Japan
International Sales Division
THE HITACHI ATAGO BUILDING,
No. 15-12 Nishi Shinbashi, 2 - Chome,
Minato - Ku, Tokyo 105-8430, Japan.
Tel: 03 35022111

HITACHI EUROPE LTD,

Whitebrook Park
Lower Cookham Road
Maidenhead
Berkshire
SL6 8YA

UNITED KINGDOM

Tel: 01628 643000
Fax: 01628 643400
Email: consumer-service@hitachi-eu.com

HITACHI EUROPE S.A.

364 Kifissias Ave. & 1, Delfon Str.
152 33 Chalandri
Athens

GREECE

Tel: 1-6837200
Fax: 1-6835964
Email: service.hellas@hitachi-eu.com

HITACHI EUROPE GmbH

Munich Office
Dornacher Strasse 3
D-85622 Feldkirchen bei München

GERMANY

Tel: +49-89-991 80-0
Fax: +49-89-991 80-224
Hotline: +49-180-551 25 51 (12ct/min)
Email: HSE-DUS.service@hitachi-eu.com

HITACHI EUROPE S.A.

Gran Via Carlos III, 86, planta 5
Edificios Trade - Torre Este
08028 Barcelona

SPAIN

Tel: 93 409 2550
Fax: 93 491 3513
Email: atencion.cliente@hitachi-eu.com

HITACHI EUROPE srl

Via Tommaso Gulli N.39, 20147
Milano, Italia

ITALY

Tel: +39 02 487861
Tel: +39 02 38073415 Servizio Clienti
Fax: +39 02 48786381/2
Email: customerservice.italy@hitachi-eu.com

HITACHI Europe AB

Box 77 S-164 94 Kista

SWEDEN

Tel: +46 (0) 8 562 711 00
Fax: +46 (0) 8 562 711 13
Email: csgswe@hitachi-eu.com

HITACHI EUROPE S.A.S

Lyon Office
B.P. 45, 69671 BRON CEDEX

FRANCE

Tel: 04 72 14 29 70
Fax: 04 72 14 29 99
Email: france.consommateur@hitachi-eu.com

HITACHI EUROPE LTD (Norway) AB

STRANDVEIEN 18

1366 Lysaker

NORWAY

Tel: 67 5190 30
Fax: 67 5190 32
Email: csgnor@hitachi-eu.com

HITACH EUROPE AB

Egebækgård
Egebækvej 98
DK-2850 Nærum

DENMARK

Tel: +45 43 43 6050
Fax: +45 43 60 51
Email: csgnor@hitachi-eu.com

HITACHI EUROPE AB

Neopoli / Niemenkatu 73
FIN-15140 Lahti

FINLAND

Tel : +358 3 8858 271
Fax: +358 3 8858 272
Email: csgnor@hitachi-eu.com

Hitachi Europe Ltd

Bergensesteenweg 421
1600 Sint-Pieters-Leeuw

BELGIUM

Tel: +32 2 363 99 01
Fax: +32 2 363 99 00
Email: sofie.van.bom@hitachi-eu.com

HITACHI EUROPE LTD

Na Sychrove 975/8
101 27 Praha 10 - Bohdalec

CZECH REPUBLIC

Tel: +420 267 212 383
Fax: +420 267 212 385
Email: csgnor@hitachi-eu.com