

HITACHI

SERVICE MANUAL

TK

No. 0417E

DV-RF7U



DO NOT RESELL OR DIVERT IMPROPERLY.

SPECIFICATIONS AND PARTS ARE SUBJECT TO CHANGE FOR IMPROVEMENT

DVD VIDEO RECORDER with VIDEO CASSETTE RECORDER

July

2004

Digital Media Division, Tokai

Table of contents

1 Safety Precaution for Repair	1-1	4-4 VCR Deck Mechanism Disassembly	4-8
1-1 Cautions	1-1	(1) Holder FL Cassette Ass'y Removal	4-8
1-2 Use of Solder for Repairs	1-1	(2) Lever FL Arm Ass'y Removal	4-8
1-3 Use of Solder for Repairs	1-1	(3) Lever FL Door Removal	4-9
1-4 Electrostatic Protection Measures	1-2	(4) Slider FL Drive, Gear FL Cam Removal ...	4-9
1-5 Notes When Using Service Manual	1-3	(5) Gear Worm Wheel Removal	4-10
2 General Description	2-1	(6) Cable Flat Removal	4-10
2-1 Overview	2-1	(7) Motor Loading Ass'y Removal	4-11
2-1-1 Service method	2-1	(8) Bracket Gear, Gear Joint 2, 1 Removal ..	4-11
2-1-2 Disc information	2-2	(9) Gear Loading Drive, Slider Cam, Lever Load S, T Ass'y Removal	4-12
2-2 Features	2-4	(10) Lever Pinch Drive, Lever Tension Drive Removal	4-13
2-3 Specifications	2-5	(11) Lever Tension Ass'y, Band Brake Ass'y Removal	4-13
2-4 Major Differences from Previous Model ..	2-6	(12) Lever Brake S, T Ass'y Removal	4-14
2-5 Function Differences from Previous Model	2-7	(13) Gear Idle Ass'y Removal	4-14
2-6 Names of Parts	2-8	(14) Disk S, T Reel Removal	4-15
2-7 List of Abbreviations and Terms for DVD Recorder	2-11	(15) Holder Clutch Ass'y Removal	4-15
3 Details of Servicing and Troubleshooting	3-1	(16) Lever Up Down Ass'y, Gear Center Ass'y Removal	4-16
3-1 Details of Servicing	3-1	(17) Guide Cassette Door Removal	4-17
3-1-1 Removing Disc from Faulty Recorder ...	3-1	(18) Lever Unit Pinch Ass'y, Plate Joint, Spring Pinch Drive Removal	4-17
3-1-2 Removing Video Cassette from Faulty Recorder	3-1	(19) Lever #9 Guide Ass'y Removal	4-18
3-1-3 Firmware	3-2	(20) FE Head Removal	4-18
3-2 Troubleshooting	3-3	(21) ACE Head Removal	4-19
4 Disassembly and Reassembly	4-1	(22) Slider S, T Ass'y Removal	4-19
4-1 Order of Disassembly	4-1	(23) Plate Ground Deck, Cylinder Ass'y Removal	4-20
4-2 Cabinet Disassembly	4-1	(24) Hook Capstan, Belt Pulley Removal	4-20
(1) Top Cover	4-1	(25) Motor Capstan Ass'y Removal	4-21
(2) Front Panel	4-2	(26) Post #8 Guide Ass'y Removal	4-21
(3) Rear Panel and FAN Motor	4-2	4-5 The table of cleaning, Lubrication and replacement time about principal parts .	4-22
(4) DVD Multi Drive	4-3	5 Adjustment	5-1
(5) DVD Main P.C.B and Jack P.C.B	4-3	5-1 Set-up for Adjustment	5-1
(6) Front P.C.B	4-4	5-2 VCR Electrical Adjustment	5-2
(7) Deck Mechanism	4-4	5-2-1 Reference	5-2
(8) Key P.C.B and VCR Main P.C.B	4-5	5-2-2 Head Switching Adjustment	5-3
4-3 VCR Deck Parts Locations	4-6	5-2-3 NVRAM Option Setting	5-3
4-3-1 Top View	4-6	5-3 VCR Mechanism Adjustment	5-4
4-3-2 Bottom View	4-7	5-3-1 Tape Transport System and Adjustment Locations	5-4

5-3-2	Tape Transport System Adjustment	5-5
5-3-3	Reel Torque	5-10

6 Exploded View and Parts List..... 6-1

6-1	Exploded Views	6-1
6-1-1	Cabinet Section	6-1
6-1-2	Deck Mechanism Section-Top view	6-2
6-1-3	Deck Mechanism Section-Bottom view	6-3
6-2	Parts List	6-4
6-2-1	Mechanical Parts List	6-4
6-2-2	Electrical Parts List	6-5

S Schematic, Wiring Diagrams S-1

S-1	Wiring Diagram	S-1
S-2	S.M.P.S Schematic Diagram	S-2
S-3	Power Schematic Diagram	S-3
S-4	Logic Schematic Diagram	S-4
S-5	A/V Schematic Diagram	S-5
S-6	Hi/Fi/MTS Schematic Diagram	S-6
S-7	MUX & TM & A/V Input Schematic Diagram	S-7
S-8	MUX Connector Schematic Diagram	S-8
S-9	Audio Out Schematic Diagram	S-9
S-10	Video Out Schematic Diagram	S-10
S-11	Front/Key Schematic Diagram	S-11

C Circuit Board Diagrams C-1

C-1	VCR Main P.C.B	C-1
C-2	Jack P.C.B	C-3
C-3	Front P.C.B	C-5
C-4	Key P.C.B	C-5

B Block Diagram B-1

1-1 Cautions

PRODUCT SAFETY NOTICE

Many electrical and mechanical parts have special safety-related characteristics. These are often not evident from visual inspection nor can the protection afforded by them necessarily be obtained by using replacement components rated for a higher voltage, wattage, etc. Replacement parts which have these special safety characteristics are identified in this Service Manual. Electrical components having such features are identified by marking with a \triangle on the schematics and the parts list in this Service Manual. The use of a substitute replacement component which does not have the same safety characteristics as the HITACHI recommended replacement one, shown in the parts list in this Service Manual, may create shock, fire, or other hazards. Product safety is continuously under review and new instructions are issued from time to time. For the latest information, always consult the current HITACHI Service Manual. A subscription to, or additional copies for, HITACHI Service Manual may be obtained at a nominal charge from HITACHI SALES CORPORATION.

CAUTION CLASS 2M LASER RADIATION WHEN OPEN.
DO NOT STARE INTO THE BEAM OR VIEW
DIRECTLY WITH OPTICAL INSTRUMENTS.

CLASS 1
LASER PRODUCT

CAUTION

This product contains a laser diode of higher class than 1. To ensure continued safety, do not remove any covers or attempt to gain access to the inside of the product. Refer all servicing to qualified personnel.

CAUTION

There is a high-voltage section inside the DVD recorder. When repairing or inspecting it, take great care to prevent electric shock: Use an isolating transformer, wear gloves, etc.

1-2 Use of Solder for Repairs

Lead-based solder is used for the printed circuit boards in this recorder.

Therefore, when servicing, use lead-based solder and set the temperature at the tip of soldering iron 30 - 40 °C lower than when using lead-free solder.

1-3 Electrostatic Protection Measures

Semiconductor components can be damaged by static electricity charged on clothes, human body, etc. Take great care when handling components to avoid electrostatic damage, and perform servicing in an environment where grounding is complete.

(1) Grounding work bench

Lay out an antistatic mat on work bench, and then use the ground plate to ground the work bench.

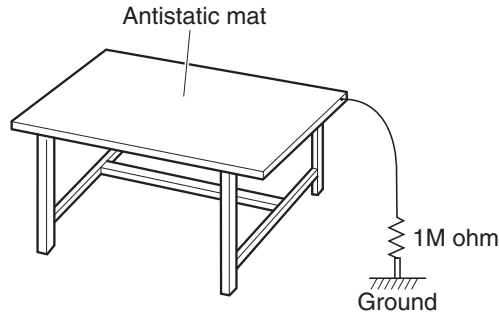

(2) Grounding human body

Use an antistatic wrist strap to discharge any static electricity charged on the body. Also, use a tester for wrist strap to make sure that the wrist strap is working normally. Note, however, that static electricity charged on clothes will not be discharged by wrist strap: Therefore do not allow your clothes to touch the semiconductor components.

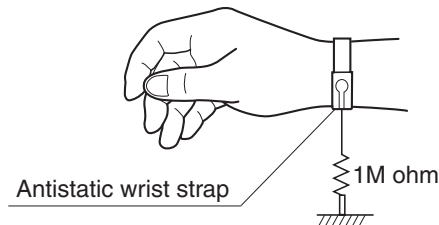

1-4 Cautions When Handling DVD Drive

The optical pickup in DVD drive has a high precision structure: Be sure to observe the following cautions.

- 1) Do not subject optical pickups to any severe vibrations or impact during movement, installation or disassembly.
- 2) When performing repair work, do not perform disassembly any further than that described in this manual.
- 3) Never turn the semi-variable resistors for adjustment in optical pickup or DVD drive.
- 4) NEVER look into the objective lens in optical pickup or directly view the laser light: You could lose your eyesight.

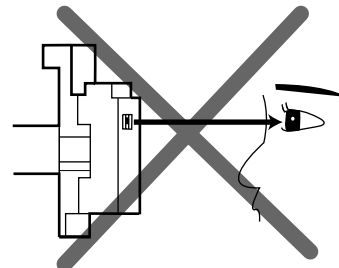

Do not directly look at laser light from pickup.

1-5 Notes When Using Service Manual

(1) Value units used in parts list

Certain symbols are indicated as shown below for value units of resistors, capacitors and coils in parts list. When you read them, note the following regular indications:

Parts	Indication in list	Regular indication
Resistor	KOHM	k Ω
Capacitor	UF	μ F
	PF	pF
Coil	UH	μ H
	MH	mH

(2) Values in schematic diagrams

The values, dielectric strength (power capacitance) and tolerances of the resistors (excluding variable resistors) and capacitors are indicated in the schematic diagrams using abbreviations. Certain symbols are indicated for value units: When you read them note the regular indications in tables below:

[Resistors]

Item	Indication
Value	No indication Ω
	K k Ω
	M M Ω
Tolerance	No indication $\pm 5\%$ (All tolerances other than $\pm 5\%$ are indicated in schematic diagrams)
Power capacitance	No indication 1/8W (1/16 W for leadless resistors with no indication) All capacitances other than the above are indicated in schematic diagrams.

[Capacitors]

Item	Indication
Value	No indication μ F
	P pF
Dielectric strength	No indication 50V (All dielectric strengths other than 50 V are indicated in schematic diagrams)

[Coils]

Item	Indication
Value	μ μ H
	m mH

2 General Description

2-1 Overview

Model DV-RF7U is a multi-drive DVD recorder with VCR: It can record on DVD-RAM, DVD-RW and DVD-R discs and play them back.

The DV-RF7U can handle DVD-RW discs for recording and playback in Video format and VR (Video Recording) format, and DVD-RAM discs of both cartridge type (12 cm) and non-cartridge type.

The DV-RF7U can play back 8 cm DVD-R discs recorded on Hitachi DVD video camera/recorders even when they are not yet finalized: It also has a DV input jack with which digital dubbing is possible from digital video cameras.

The DV-RF7U also allows one-button dubbing from VHS videotape to DVD, and vice versa.

2-1-1 Service method

Basically, components are replaced when servicing the DV-RF7U. However, the service method is different for high-density packaging PCBs and precision components.

Refer to the following table and perform the designated, appropriate servicing. Any changes that occur in the service method will be published using service bulletin, etc.

Do not perform any servicing other than that described in this manual.

Component	Service method
Exterior component	Component replacement
DVD Multi Drive	Unit replacement
DVD Main P.C.B	Circuit board assembly replacement
VCR Main P.C.B	Component replacement
Front P.C.B	Component replacement
Key P.C.B	Component replacement
Jack P.C.B	Component replacement
Deck mechanism	Component replacement

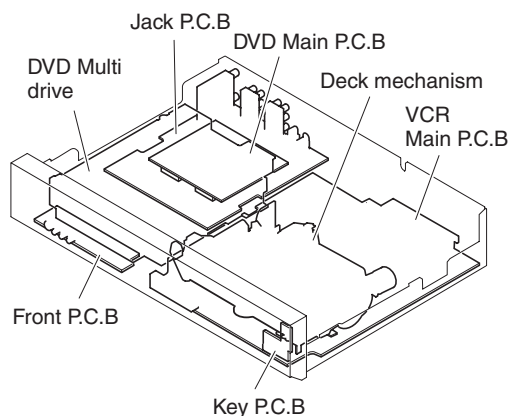

Fig. 2-1-1 Component Location

2-1-2 Disc information

DVD-Video

- A digital versatile disc (DVD) can contain up to 135 minutes of images, 8-language audio and 32 subtitle languages. It is equipped with MPEG-2 picture compression and Dolby 3D surround, allowing you to enjoy vivid and clear theater quality images in the comfort of your own home.
- When switching from the first layer to the second layer of a double-layered DVD Video disc, there may be momentary distortion in the image and sound. This is not a malfunction of the unit.
- Once a DVD-R/RW recorded in Video Mode is finalized, it becomes DVD-Video.

Audio CD

- An audio disc on which 44.1kHz PCM Audio is recorded.
- Plays CD-DA format audio CD-R and CD-RW discs. This unit may not be able to play some CD-R or CD-RW discs due to the condition of the recording.

CD-R/RW

MP3 CD-R/RW

- Only CD-R discs with MP3 files recorded with ISO9660 or JOLIET format can be played back.
- Only MP3 files with the ".mp3", and ".MP3" extension can be used.
- For MP3 files recorded with a VBR (Variable Bit Rates), from 32 Kbps to 320 Kbps, the sound may cut in out.
- Playable bit rate range is from 56Kbps to 320Kbps.
- The unit can handle a maximum of 1000 files and folders.

JPEG CD-R/RW

- Only JPEG files with the ".jpg", ".JPG" extension can be used.
- The unit can handle a maximum of 1000 files and folders.
- Maximum size of progressive JPEG is 3M pixels.
- MOTION JPEG is not supported.

Using CD-R/RW

- If the CD-R/RW disc was not recorded as a closed session, you may experience a delay in the early play back time, and all recorded files may not play.
- Some CD-R/RW discs may not be playable with this unit, depending on the device which was used to burn them. For contents recorded on CD-R/RW media from CDs for your personal use, playability may vary depending on contents and discs.

DVD-R Disc Playback and Recording

- Once a DVD-R/RW recorded in Video Mode is finalized, it becomes DVD-Video.
- You can record onto the available space on the disc and perform editing functions such as giving titles to discs and programs and erasing programs before finalizing.
- When programming is erased from a DVD-R, that space does not become available. Once an area on a DVD-R is recorded on, that area is no longer available for recording, whether the recording is erased or not.
- It takes about 30 seconds for the unit to complete recording management information after recording finishes.
- This product optimizes the DVD-R for each recording. Optimizing is carried out when you start recording after inserting the disc or turn on the unit. Recording onto the disc may become impossible if optimizing is carried out too many times.
- Playback may be impossible in some cases due to the recording condition.
- This unit can play back DVD-R discs recorded and finalized with a DVD video recorder. It may not be able to play some DVD-R discs depending on the disc and the recording condition.

DVD-RW Disc Playback and Recording

- Recording and playback can be performed on DVD-RW discs in both Video and VR Modes.
- Once a DVD-RW recorded in VR Mode is finalized, you cannot perform additional recording.
- Once a DVD-RW recorded in Video Mode is finalized, it becomes DVD-Video.
- In both modes, playback can be performed before and after finalization, but additional recording, deleting and editing cannot be performed after finalization.
- If you want to record the disc in VR Mode and then record in V Mode, be sure to execute Format. Be careful when executing Format because all the recorded data may be lost.
- A DVD-RW blank disc is initialized to Video Mode when first initialized.
- **DVD-RW (VR mode)**
 - This is a format that is used for recording data on a DVD-RAM or DVD-RW disc. You can repeat recording, editing, deleting, partial deletion, creation of playlist, etc.
 - A disc that is recorded in this mode may not be played by existing DVD players.
- **DVD-RW (Video mode)**
 - This is a format that is used for recording data on a DVD-RW or DVD-R disc. The disc can be played by an existing DVD player once it has been finalized.
 - If a disc that has been recorded in Video mode by a different manufacturer's recorder, but has not been finalized, it cannot be played or additionally be recorded by this recorder.

DVD-RAM Disc Playback and Recording

- DVD-RAM discs come with or without a cartridge. For this product, we recommend DVD-RAM discs that come with cartridges.
- Some cartridges are able to eject the disc inside. Even if you are able to eject the disc, always use the disc with the cartridge to ensure correct operation.
- DVD-RAM discs have a Write Protect tab in order to avoid accidental erasure of recorded data. With the Write Protect tab set to PROTECT, you can play the disc, but recording or erasing will not work. Set the Write Protect tab to UNPROTECT to format the disc or erase data.
- Ensure that the recording mode is set to VR mode. Otherwise, this product will not be able to play the recording.
- You cannot play a DVD-RAM in most DVD players due to compatibility issues.
- Only DVD-RAM standard Version 2.0 discs can be played in this unit.
- DVD-RAM recorded on this unit may not work with other DVD Players. To determine compatibility with these DVD-RAM discs, refer to the user's manual for the player.
- This unit is compatible with both non-cartridge and cartridge DVD-RAM, but the write-protect tabs on cartridge-type discs give better protection to your recordings.

COPY PROTECTION

- Many DVD discs are encoded with copy protection. Because of this, you should only connect your DVD Recorder-VCR directly to your TV, not to a VCR. Connecting to a VCR results in a distorted picture from copy-protected DVD discs.
- This product incorporates copyright protection technology that is protected by methods claims of certain U.S. patents and other intellectual property rights owned by Macrovision Corporation and other rights owners. Use of this copyright protection technology must be authorized by Macrovision Corporation, and is intended for home and other limited viewing uses only unless otherwise authorized by Macrovision Corporation. Reverse engineering or disassembly is prohibited.

Protection

This DVD Recorder-VCR can allow you to protect the contents of your discs, as described below.

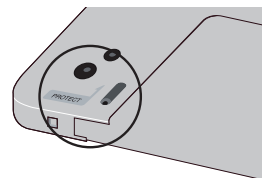

- Cartridge-protected:
 - With the write-protect tab set in the protect position, the contents of the disc cannot be recorded, edited, or erased.
- Program-protected: "Locking a Title List Entry"
- Disc-protected: "Disc Protection"
 - * DVD-RAM/DVD-RW/DVD discs that are incompatible with the DVD-VIDEO format cannot be played with this product.
 - * For more information on recording a DVD, consult your DVD-RAM/DVD-RW/DVD-R manufacturer.
 - * If poor quality DVD-RAM/DVD-RW/DVD-R discs are used, your recordings may fail.

Do not use the following discs!

- LD, CD-G, CD-I, CD-ROM, DVD-ROM, VCD, DVD+R and DVD+RW discs should not be used in this product.

[Note]

- Disc types that can be played : CD/CD-R/CD-RW/MP3/JPEG/DVD-Video/DVD-RAM/ DVD-RW/DVD-R.
- However, if your DVD-RW disc was recorded with another device, it can be played only if it was recorded and finalized in Video Mode.
- Some commercial discs and DVD discs purchased outside your region may not be playable with this product. When these discs are played, either "No disc." or "Please check the regional code." will be displayed.
 - If your DVD-RW disc is an illegal copy or is not in DVD video format, it may also not be playable.

- * We recommend using Hitachi Maxell discs as they have been confirmed to be compatible with this unit. Other discs may not perform correctly.

2-2 Features

DV-RF7U allows you to record and play back high quality digital images on a DVD-RAM/DVD-RW/DVD-R disc. You can also edit digital images on DVD-RAM/DVD-RW discs.

(1) High quality digital audio and video recording and playback

Record up to about 12-hour images with a double sided 9.4 GB DVD-RAM disc, and up to about 6-hour images with a 4.7 GB DVD-RAM disc, depending on the recording mode.

(2) Creating DVD video title using DVD-RW/DVD-R disc

With DV-RF7U, create your own DVD video title on 4.7 GB DVD-RW/DVD-R discs.

(3) A Variety of Recording Options

Select an appropriate recording mode between XP, SP, LP and EP to meet your recording needs.

- XP mode - High quality, about 1 hour
- SP mode - Standard quality, about 2 hours
- LP mode - Low quality, about 4 hours
- EP mode - Lower quality, about 6 hours

(4) Copying digital camcorder content using DV input jack

Record digital camcorder images onto DVD-RAM/DVD-RW/DVD-R discs using the DV input jack (IEEE 1394-4pin).

(5) Time Slip and Picture In Picture (PIP)

Use the Time Slip function to play back the recorded images while a recording is proceeding (DVD-RAM only). Use the PIP function to view the playback and recording screens at the same time.

(6) High quality progressive scan

Progressive scanning provides high resolution and flicker free images. The 10-bit 54-MHz DAC, 2D Y/C Separating circuitry and Time Base Corrector processor technology provide you with the highest image playback and recording quality.

(7) A variety of functions with easy-to-use user interface

Integrated menu system and messaging functionality allow you to perform the desired operations easily and conveniently. With a DVD-RAM/DVD-RW(VR mode) disc, you can edit recorded images, create playlist, and edit images in specific sequence according to your needs.

2-3 Specifications

General	Power requirements	120 VAC, 60 Hz
	Power consumption/Standby power (W)	45 Watts/5.1 Watts
	Weight	Approx. 5.3 kg (11.6 lb)
	Dimensions	Approx. 430 mm (W) x 333 mm (D) x 84 mm (H) [Approx. 16.9 in (W) x 13.1 in (D) x 3.3 in (H)] (excluding projections)
	Operating temp.	+5°C to +40°C (+41°F to +95°F)
	Operating humidity	Keep level when operating. Less than 80% operating humidity
Input	Video	1.0 V p-p at 75 ohm load, sync negative S-Video input (Y: 1.0 Vp-p, C: 0.286 Vp-p at 75 ohm load)
	Max. Audio Input Level	2 Vrms
	DV Input	IEEE 1394(4p) compatible jack
	Receivable Channels	Regular TV broadcasting: VHF (2~13), UHF (14~69) Cable TV broadcasting: 1~125
Output	Audio	Audio input jacks 1, 2 Optical/Coaxial digital audio output
	Video	Video input jacks 1, 2 S-Video output 1 (Y: 1.0 Vp-p, C: 0.286 Vp-p at 75 ohm load) Component output (Y: 1.0 Vp-p, Pb: 0.70 Vp-p, Pr: 0.70 Vp-p at 75 ohm load)
DVD	Picture Compression format	MPEG-II
	Audio Compression format	Dolby AC-3 256 kbps
	Recording time	Max (6 hour) (using 4.7 GB disc): XP (60 min), SP (120 min), LP (240 min), EP (360 min)
	Video S/N Ratio	Min. 50 dB at standard recording
	Audio S/N Ratio	Min. 75 dB
	Audio frequency characteristics	20 Hz ~ 20 kHz



Audio Output

For DVD discs, audio signals recorded at 96kHz sampling frequency are converted into and output at 48kHz digital signal.

Disc Type	DVD	VIDEO-CD	AUDIO CD(CDDA)
Analog Audio Output	48 / 96 kHz	44.1 kHz	44.1 kHz
Digital Audio Output	48 kHz	44.1 kHz	44.1 kHz

2-4 Major Differences from Previous Model

← : Same as on left

Item	DV-RF7U	DV-RX5000U
Appearance		
Dimensions	430(W) x 333(D) x 84(H)mm	430(W) x 283(D) x 79(H)mm
Power consumption	Approx. 45 W Standby power: Approx. 5.1 W	Approx. 26 W Standby power: Approx. 3.2 W
Recordable media	12 cm (5") 4.7 GB DVD-RAM discs 12 cm (5") 9.4 GB DVD-RAM discs 8 cm (3") 2.8 GB DVD-RAM discs 12 cm (5") 4.7 GB DVD-RW discs (Ver.1.1/Ver.1.1 with CPRM) 12 cm (5") 4.7 GB DVD-R discs 8 cm (3") 1.4 GB DVD-R discs (for General Ver. 2.0) 12 cm (5") 4.7 GB DVD-R discs (for General Ver.2.0/ 4X-SPEED DVD-R Revision 1.0) VHS	12 cm (5") 4.7 GB DVD-RAM discs 12 cm (5") 9.4 GB DVD-RAM discs 8 cm (3") 2.8 GB DVD-RAM discs 12 cm (5") 4.7 GB DVD-R discs 8 cm (3") 1.4 GB DVD-R discs (for General Ver. 2.0)
Playable media	12 cm (5") 4.7 GB DVD-RAM discs 12 cm (5") 9.4 GB DVD-RAM discs 8 cm (3") 2.8 GB DVD-RAM discs 12 cm (5") 4.7 GB DVD-RW discs (Ver.1.1/Ver.1.1 with CPRM) 12 cm (5") 4.7 GB DVD-R discs 8 cm (3") 1.4 GB DVD-R discs (for General Ver. 2.0) DVD-VIDEO discs CD-Audio discs (CD-DA) CD-R/CD-RW discs (CD-DA, MP3 formatted discs) VHS/S-VHS (SQPB)	12 cm (5") 4.7 GB DVD-RAM discs 12 cm (5") 9.4 GB DVD-RAM discs 8 cm (3") 2.8 GB DVD-RAM discs 12 cm (5") 4.7 GB DVD-R discs 8 cm (3") 1.4 GB DVD-R discs (for General Ver. 2.0) DVD-VIDEO discs CD-Audio discs (CD-DA) Video CD discs CD-R/CD-RW discs (CD-DA, Video CD, MP3 formatted discs)
Remote control	DV-RMRF7U	DV-RM5000U
DV input terminal	1 (Front)	No
S-VIDEO input terminal	1 (Front)	3 (Front: 1, Rear: 2)
VIDEO/AUDIO input terminals	2 (Front: 1, Rear: 1)	3 (Front: 1, Rear: 2)
COMPONENT VIDEO output terminal	1 (Rear)	←
S-VIDEO output terminal	1 (Rear)	←
VIDEO output terminal	1 (Rear)	←
Analog AUDIO output terminals	2 (Rear)	1 (Rear)
Digital AUDIO output terminals	2 (Optical: 1, Coaxial: 1)	1 (Optical: 1)
Progressive button	Yes (Front)	Yes (SETUP screen)

2-5 Function Differences from Previous Model

← : Same as on left

		Item	DV-RF7U	DV-RX5000U
DVD section	Recording	Digital Recording (DV to DVD)	Yes	No
		Dubbing (VCR to DVD)	Yes	No
		Time Slip	Yes	←
		One Touch Recording (OTR)	Yes	←
		AUTO recording mode	Yes	Yes (Flexible Recording Mode)
		Simultaneous rec and play	Yes	←
	Playback	Title List Playback	Yes	Yes (Direct Navigator)
		Time Navi	Yes	←
		Skipping	Yes (30 seconds)	Yes (CM Skip)
		Manual Skip	Yes	←
		Marker	Yes	←
		Zooming In	Yes	No
		Photo CD Playback (JPEG)	Yes	No
		MP3 Playback	Yes	←
		P in P	Yes	No
		Repeat Play	Yes	←
		A-B Repeat Play	Yes	←
		Camera Angle Function	Yes	←
		Virtual Surround	Yes	←
		Slow Motion Play	Yes	←
		Step Motion Play	Yes	←
	Position Memory	Yes	←	
	Other	Disk Manager	Yes	←
Edit Title List		Yes	←	
Edit Playlist		Yes	←	
Divide Program		No	Yes	
VCR section	Recording	Digital Recording (DV to VCR)	Yes	---
		Dubbing (DVD to VCR)	Yes	---
		Playlist dubbing (DVD to VCR)	Yes	---
		One Touch Recording (OTR)	Yes	---
	Playback & Variable Search	Picture Search/Jet Search	Yes	---
		S-VHS Playback	Yes	---
	Variable Search	Go To [0:00:00] Stop	Yes	---
		End Search	Yes	---
	Forward Intro Scan/Reverse Intro Scan	Yes	---	

2-6 Names of Parts

Front Panel

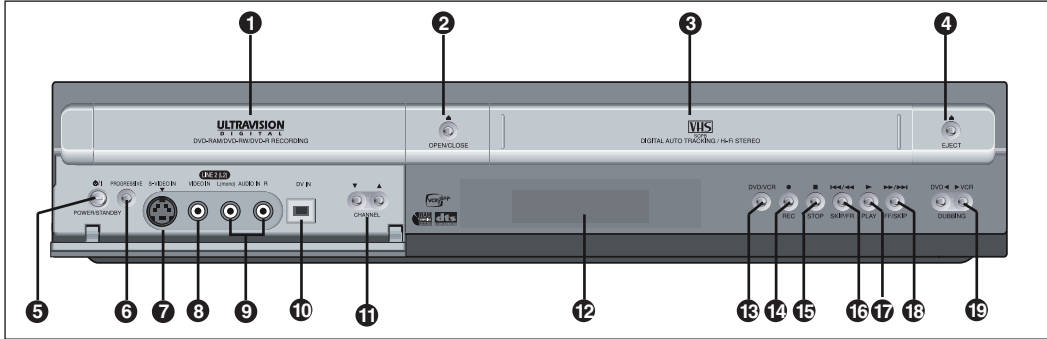

- | | |
|-------------------------|--------------------------|
| 1 DVD DECK | 11 CHANNEL V / ^ BUTTON |
| 2 DVD OPEN/CLOSE BUTTON | 12 FRONT PANEL DISPLAY |
| 3 VCR DECK | 13 DVD/VCR SELECT BUTTON |
| 4 VCR EJECT BUTTON | 14 RECORD BUTTON |
| 5 POWER BUTTON | 15 STOP BUTTON |
| 6 PROGRESSIVE BUTTON | 16 SKIP/FR BUTTON |
| 7 S-VIDEO INPUT JACK | 17 PLAY BUTTON |
| 8 VIDEO INPUT JACK | 18 F.F/SKIP BUTTON |
| 9 AUDIO L/R INPUTS JACK | 19 DUBBING BUTTON |
| 10 DV INPUT JACK | |

Front Panel Display

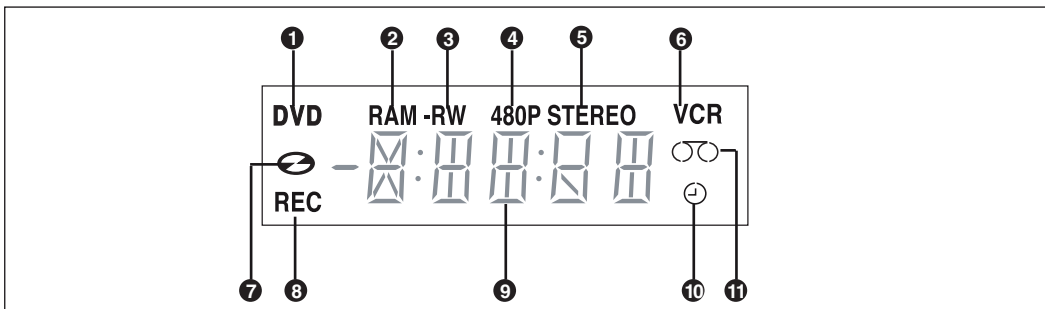

- | | |
|---|--|
| 1 When the indicator is on, DVD is activated. | 7 DVD or CD media is loaded. |
| 2 DVD-RAM is activated. | 8 Record function is working. |
| 3 DVD-R or DVD-RW is activated. | 9 The time, counter position or current deck status is indicated. |
| 4 Progressive Scan mode is working. | 10 When you set a Timer recording, or current-deck status is indicated, this indicator, it is lit. |
| 5 When you watch SAP/STEREO channel or playback Hi-Fi VCR tapes, STEREO indicator lights. | 11 VHS Videotape is loaded. |
| 6 VCR is activated. | |

Rear Panel

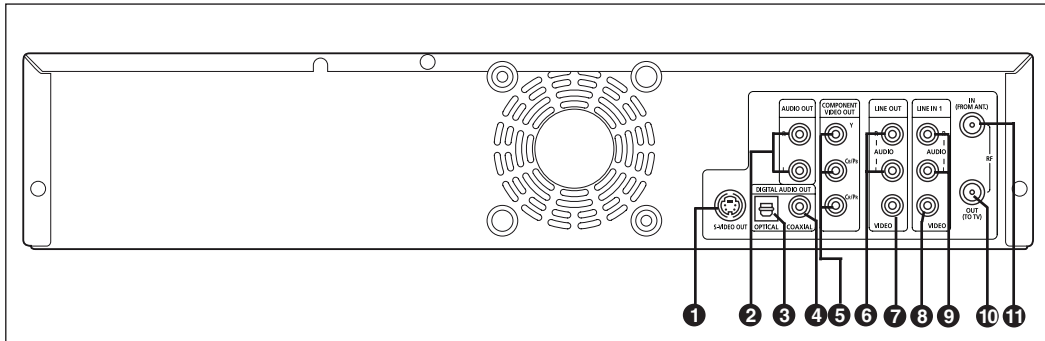

- | | |
|------------------------------------|-------------------------|
| ❶ S-VIDEO OUT JACK | ❷ VIDEO OUT JACK |
| ❸ AUDIO OUT L/R JACK | ❸ VIDEO IN JACK |
| ❹ DIGITAL AUDIO OUT JACK (OPTICAL) | ❹ AUDIO IN R/L JACK |
| ❺ DIGITAL AUDIO OUT JACK (COAXIAL) | ❺ RF OUT TO TV JACK |
| ❻ COMPONENT VIDEO OUT JACK | ❻ RF ANTENNA INPUT JACK |
| ❼ AUDIO OUT R/L JACK | |

Remote Control

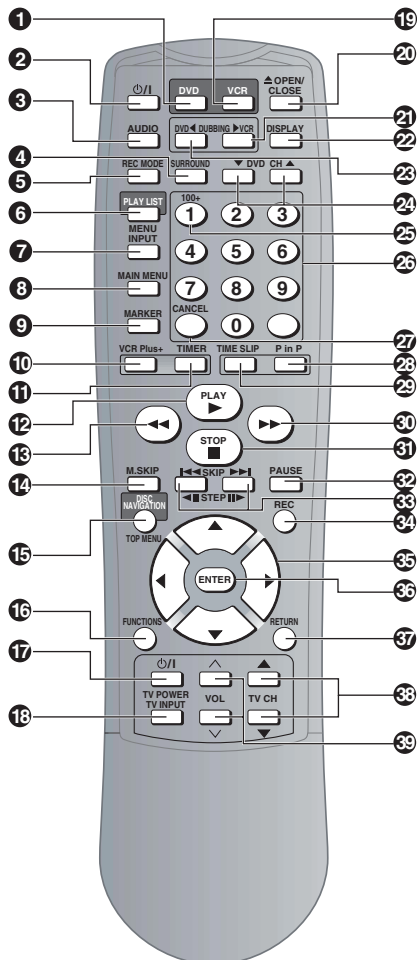

- ❶ **DVD Button**
Press this when you use a DVD.
- ❷ **POWER Button**
- ❸ **AUDIO Button**
Use this to access various audio functions on a disc (DVD mode).
This operates as sound mute. (TV mode)
- ❹ **SURROUND Button**
Gives surround-sound effect even with only two front speakers (L/R).
- ❺ **REC MODE Button**
- ❻ **MENU/PLAY LIST Button**
Use this to return to the Title menu, or to view the recorded files list.
- ❼ **INPUT Button**
Select line input signal in external input mode (Tuner or Line input)
- ❽ **MAIN MENU Button**
Brings up the DVD Recorder-VCR's setup menu.
- ❹ **MARKER Button**
Use this to bookmark a position while playing a disc.
- ❺ **VCR Plus+ Button**
Press this button and input VCR Plus+ codes to preset the timer for recording.
- ❺ **TIMER Button**
Used to preset the timer for programmed recording.

- 12 **PLAY Button**
- 13 **REVERSE Button**
- 14 **MANUAL SKIP Button**

Pressing this button during playback will skip to a scene 30 seconds forward.
- 15 **TOP MENU/DISC NAVIGATION Button**

Use this to enter the View Recoding list/disk menu.
- 16 **FUNCTIONS Button**

Use this to view the status of the disc that is being played.
- 17 **TV POWER Button**
- 18 **TV INPUT Button**

To switch the TV channel to that for external input.
- 19 **VCR Button**
- 20 **OPEN/CLOSE Button**

To open and close the disc tray.
- 21 **VCR DUBBING Button**

Press this when you copy DVD to VCR.
- 22 **DISPLAY Button**

This will display current setting or disc status.
- 23 **DVD DUBBING Button**

Press this when you copy VCR to DVD.
- 24 **DVD CHANNEL Buttons**

To switch the channel on this DVD Recorder-VCR.
- 25 **1/100+ Button**

Extended pressing of numeric button "1" will deliver "100".
- 26 **Numerical Buttons**
- 27 **CANCEL Button**
- 28 **P in P Button**

Use to watch a subprogram on the PIP screen while watching the main program on the main screen.
- 29 **TIME SLIP Button**
- 30 **FORWARD Button**
- 31 **STOP Button**
- 32 **PAUSE Button**

Use this to pause during recording or Playback.
- 33 **SKIP/STEP Button**
- 34 **REC Button**

Use to make a recording on DVD-RAM/-RW/-R discs.
- 35 **DIRECTION Buttons**

(UP/DOWN or LEFT/RIGHT Buttons)
- 36 **ENTER Button**
- 37 **RETURN Button**

Returns to a previous menu.
- 38 **TV CHANNEL Buttons**

Use this to select a TV channel.
- 39 **TV VOLUME Buttons**

TV volume adjustment

2-7 List of Abbreviations and Terms for DVD Recorder

Index	Abbreviation/Term	Explanation
A	AC3	See Dolby AC3.
B	Black Level	Function to correct the gradations on dark portions to make dark scenes easier to see.
C	CPRM	Content Protection for Recordable Media: Copyright protection function that is suitable for online distribution of music.
	CD-R	One type of DVD standard disc, to which writing once is possible (recordable type)
	CD-RW	One type of CD standard disc, to which writing up to 1000 times is possible
	Component video output terminals	Used for outputs of HDTV video signal format. Since signals for brightness and colors are independently handled for components signals (Y: luminance signal; PR/PB: chrominance signals), degrading of image will be reduced.
D	Decoder	A device that decodes the data coded and recorded on DVD Video and restores it to video and audio signals. This processing is referred to as decoding.
	Dynamic Range	A difference between maximum and minimum levels of audio recorded on disc: Measured in decibel (dB) units. If the dynamic range is compressed (audio DRC), the minimum signal level will increase and the maximum signal level will decrease: This will reduce the higher audio signal - such as burst sound - so that the low-level audio signal - such as human voice - can be heard more clearly.
	Dolby AC3	Audio coding format developed by Dolby Laboratories in U.S, also simply referred as AC3 format: Supports 5-channel full-range sound and one channel for sub-woofer sound playback.
	DRC	Dynamic Range Control: Adjusting the audio range of maximum and minimum levels (dynamic range) will improve audio signal when, for example, dialog is hard to hear or user is watching movies late at night.
	DTS	Digital Theater System: Sound system as for movie theaters developed by US Digital Theater Systems, Inc. The number of channels provided by DTS is the same for Dolby AC3.
	DVD	Digital Versatile Disc. A huge amount of digital data for video (movie) and audio can be recorded on this disc, whose size is the same as CD.
	DVD-Audio	One type of DVD standard disc, on which high-quality audio can be recorded
	DVD-R	One type of DVD standard disc, to which writing once is possible (recordable type)
	DVD-RAM	One type of DVD standard disc, to which writing up to 100,000 times is possible
	DVD-RW	One type of DVD standard disc, to which writing up to 1000 times is possible
	DVD-Video	One type of DVD standard disc, on which high-quality video and audio can be recorded
	DVD Video Format	Video recording/playback standard that applies to DVD-Video, DVD-R and DVD-RW
	DVD Video Recording Format	Video recording/playback standard that applies to DVD-RAM and DVD-RW: This allows versatile editing functions, differing from the DVD Video Format.
I	I/P/B	DVD recorders normally use data that is common between images, and individually record different data for each image. I-picture: Images recorded independently for the reference of commonly used data. P-picture: Images created from past I-picture or P-picture B-picture: Images created from both I and P pictures, which interact between both types Since I-picture delivers the highest image quality, selecting I-picture is recommended when adjusting image quality.

Index	Abbreviation/Term	Explanation
J	JPEG	Joint Photographic Expert Group: International standard format for compressing still images.
M	MPEG	Moving Picture Experts Group: Standard related to compression of digital video and audio. MPEG2 is a higher standard of MPEG and is applied to video (movie) requiring higher quality.
	MPEG Audio Layer 2	One of three audio compression standards (layers 1-3) defined by MPEG
	MP3	MPEG1 Audio Layer-3: Audio data digital compression technology.
O	Optical digital audio output	Audio is usually converted to an electrical signal and transmitted from DVD to a device such as amp: When audio is converted to a digital signal, this optical digital audio output can be transmitted on optical fiber.
P	Pan & Scan/ Letterbox	Most DVD videos are produced assuming that they will be displayed on wide TV screen (aspect ratio of 16:9): If they are displayed on TV screens with 4:3 aspect ratio, 16:9 images will not quite fit on 4:3 screens. There are two ways of displaying 16:9 images on 4:3 TV: <ul style="list-style-type: none"> · Pan & Scan: Cuts out the left and right ends of images and displays them on whole screen. · Letterbox: Reproduces 16:9 images on 4:3 screens with black bands across the top and bottom of screen.
	Playback Control (PBC)	One format to play Video CD: User can select desired screens and data while watching the displayed menu screen.
	Progressive playback function	This function converts interlaced images to non-interlaced images and displays them. It can play back 24-frame/second images included in DVD movie software, etc.
S	S-Video Output	The video signal is separated into chrominance (C) and luminance (L) signals and transmitted to TV: This delivers clearer images.
	Sampling Frequency	Sampling slices audio waves (analog signal) at a specified time interval, and digitizes the levels of the sliced waves. The slicing number per second is referred to as the sampling frequency: The higher the number, the closer the sound to the original.
	SDMI	Secure Digital Music Initiative: This conference was established by hardware makers, the Recording Industry Association of America (RIAA) and music industry companies, to protect copyrights of musical compositions.
T	Tracking	To make adjustment for clearer playback image, by reducing noise that appears on screen during videotape playback.
V	Virtual surround	This technology localizes sound at any position using only two front speakers, by subjecting the L and R signals to matrix operation. It uses the four transfer functions from L/R speakers located at specified positions to both ears of listener located in a specified position, taking into account the shape of head and the effect of earlobes, and the two transfer functions from any position to both ears.
W	WMA	Windows Media Audio: Codec that was developed by Microsoft Corporation in USA.

3 Details of Servicing and Troubleshooting

3-1 Details of Servicing

3-1-1 Removing Disc from Faulty Recorder

If disc cannot be removed due to fault, disassemble the recorder and remove the disc by the following procedure:

- 1) Remove the top cover.
[See 4-2 (1) for removal procedure.]
- 2) Remove the front panel.
[See 4-2 (2) for removal procedure.]
- 3) Use a screwdriver, etc. to move the cam slider at the right of DVD Multi drive in the direction of arrow A: The disc tray will slightly come forward.
Pull out the disc tray in the direction of arrow B. Take great care during this work so as not to damage the disc.

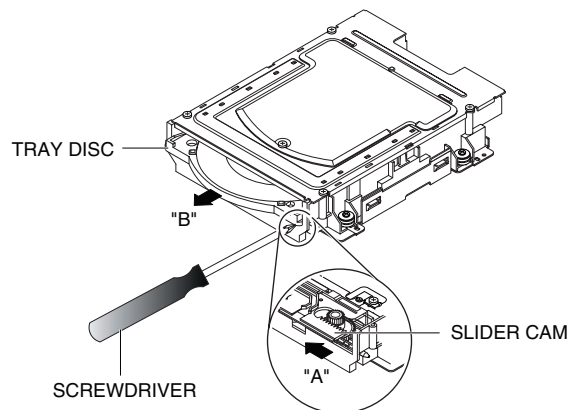

Fig. 3-1-1 Removing Disc

3-1-2 Removing Video Cassette from Faulty Recorder

If video cassette cannot be removed due to fault, disassemble the recorder and remove the video cassette by the following procedure:

- 1) Remove the top cover. [See 4-2 (1) for removal procedure.]
- 2) Remove the front panel. [See 4-2 (2) for removal procedure.]
- 3) Remove the setscrew, and then release the gear of loading motor.
- 4) Turn the gear worm wheel in the direction of arrow A: Unloading will start. When the tape starts to slacken, turn the holder clutch on the front of deck mechanism to remove slack in tape. (The holder clutch can also be turned through the hole in bottom frame.)
- 5) When unloading is complete, the VCR will enter the eject operation: Fully turn the gear worm wheel in the direction of arrow A until it stops.

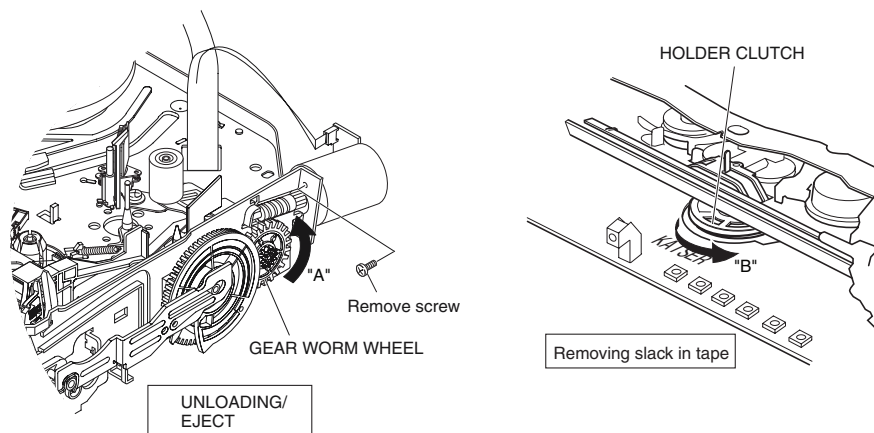

Fig. 3-1-2 Removing Video Cassette

3-1-3 Firmware

The firmware is occasionally updated to improve performance.

Check whether a customer complaint can be solved by updating of firmware: If the complaint can be solved, update the firmware.

Information:

If any corrections in firmware are made at the factory, information on how to obtain the firmware data and create a disc containing upgraded firmware will be reported in technical bulletin, etc.

(1) Version check procedure

- 1) With the recorder turned on, make sure that no disc or tape is inserted.
- 2) Hold down the CH UP + CH DOWN buttons on recorder simultaneously for approx. 5 seconds:
The version of firmware will appear on the screen.
- 3) Turn the recorder off to switch off the display.

(2) Updating Firmware

- 1) Write the firmware data to CD-R or CD-RW.
- 2) Insert the disc into the tray: Recognition of the disc will start and the screen for confirming updating will appear.
- 3) Choose [Yes], and then press the ENTER button on remote control.
- 4) When updating is complete, the tray will automatically open: Remove the disc.
- 5) Turn the recorder off, and then on again: The tray will close.
- 6) Hold down the CH UP + CH DOWN buttons on recorder simultaneously for approx. 5 seconds to display the version screen of firmware. [System reset operation]
- 7) Turn the recorder off to finish the updating of firmware.

3-2 Troubleshooting

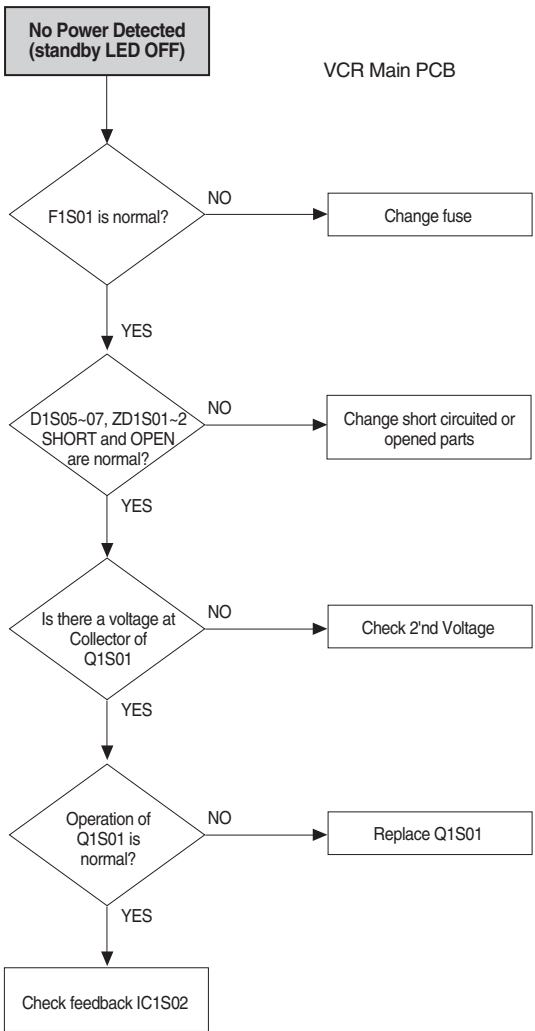
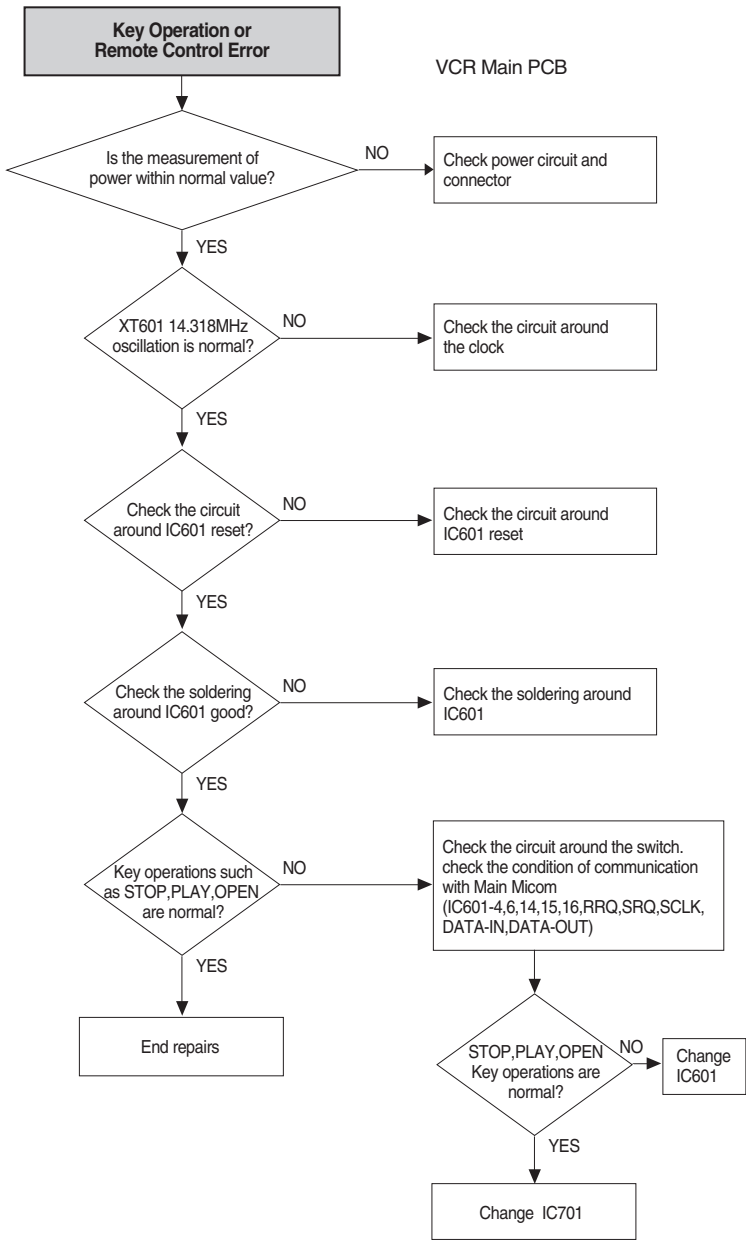

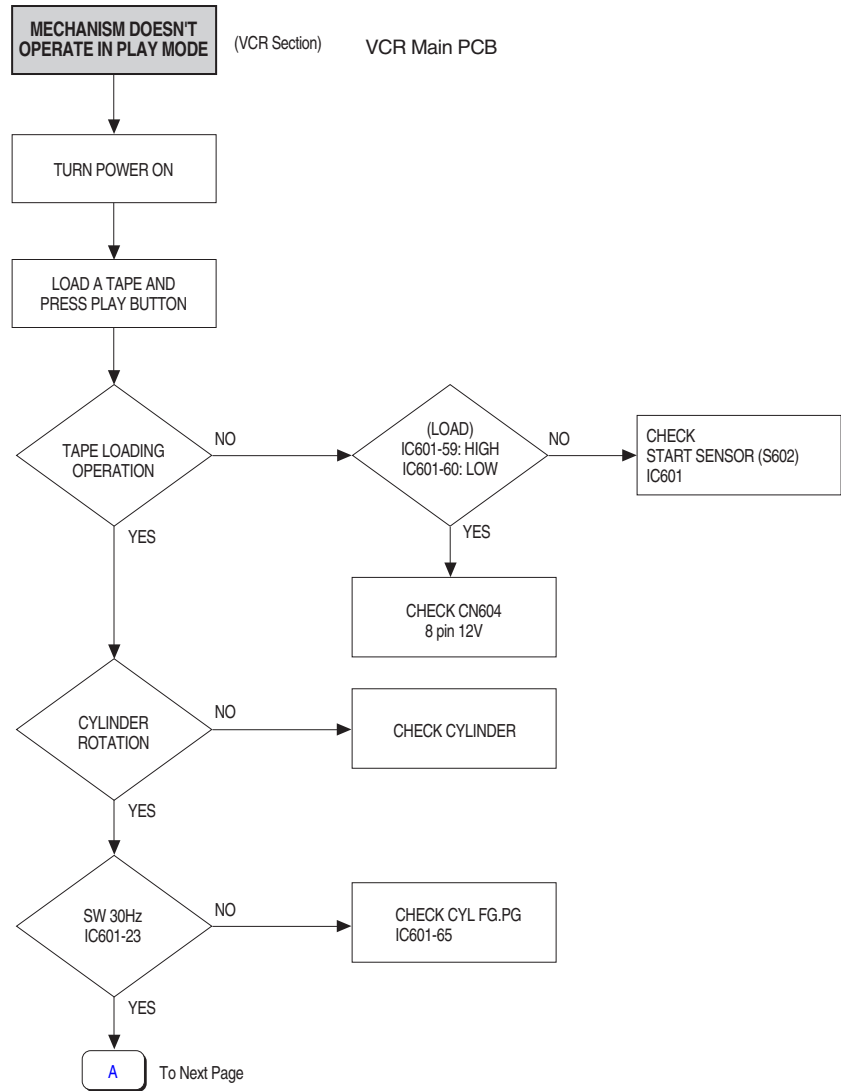
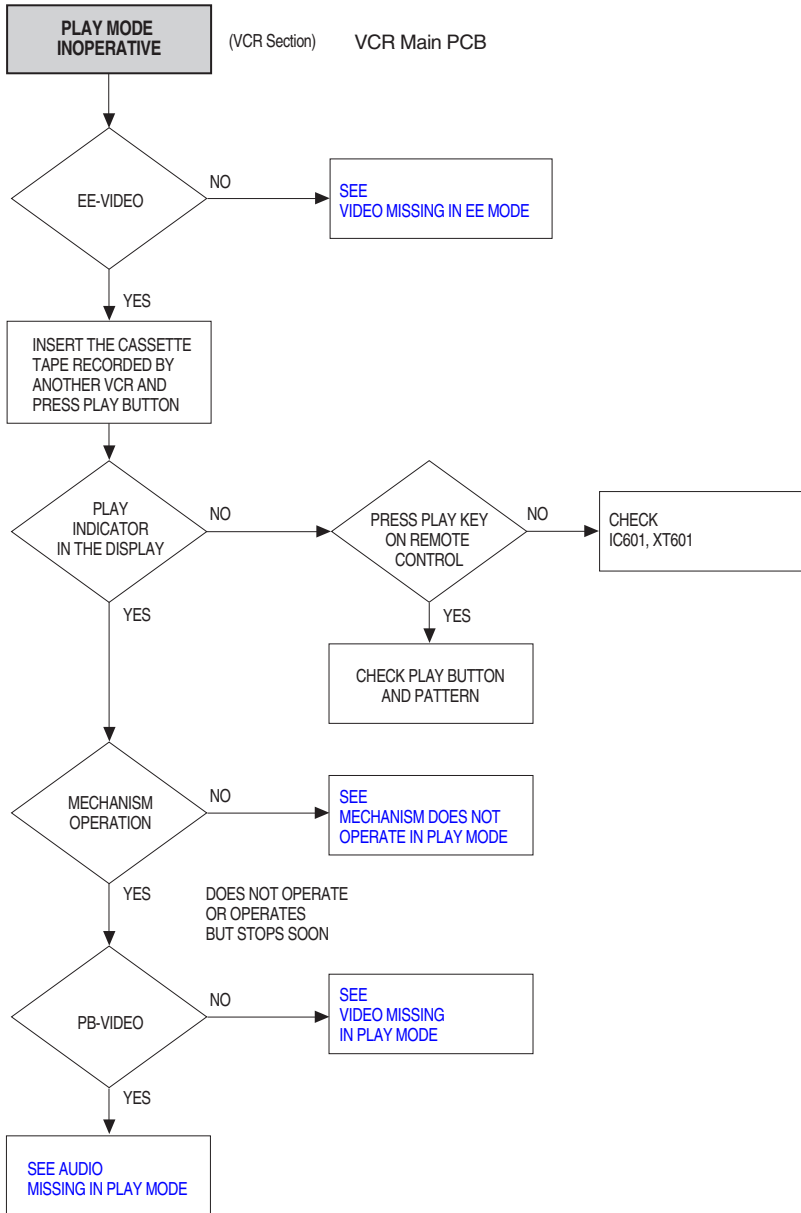

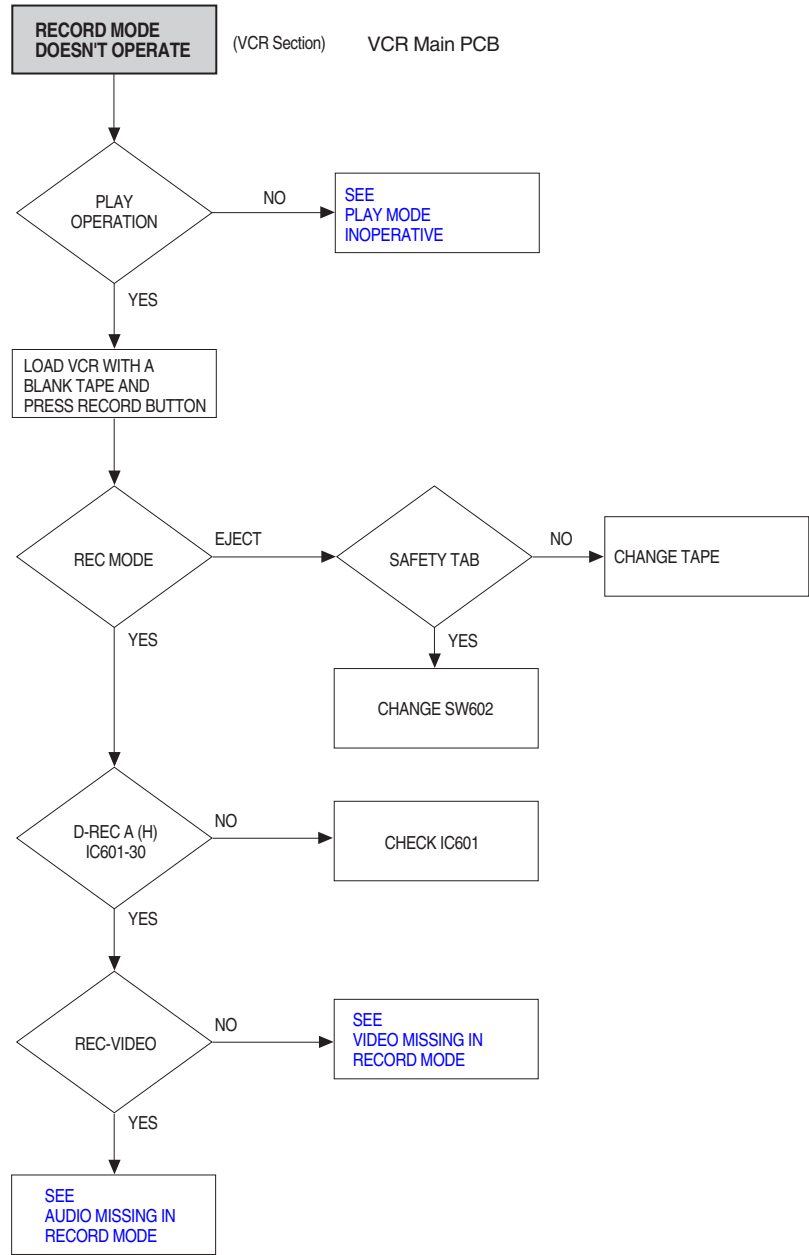
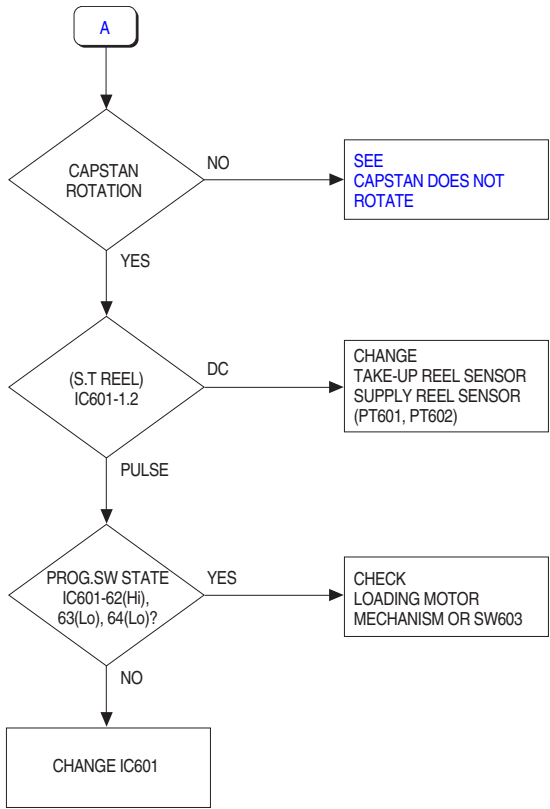

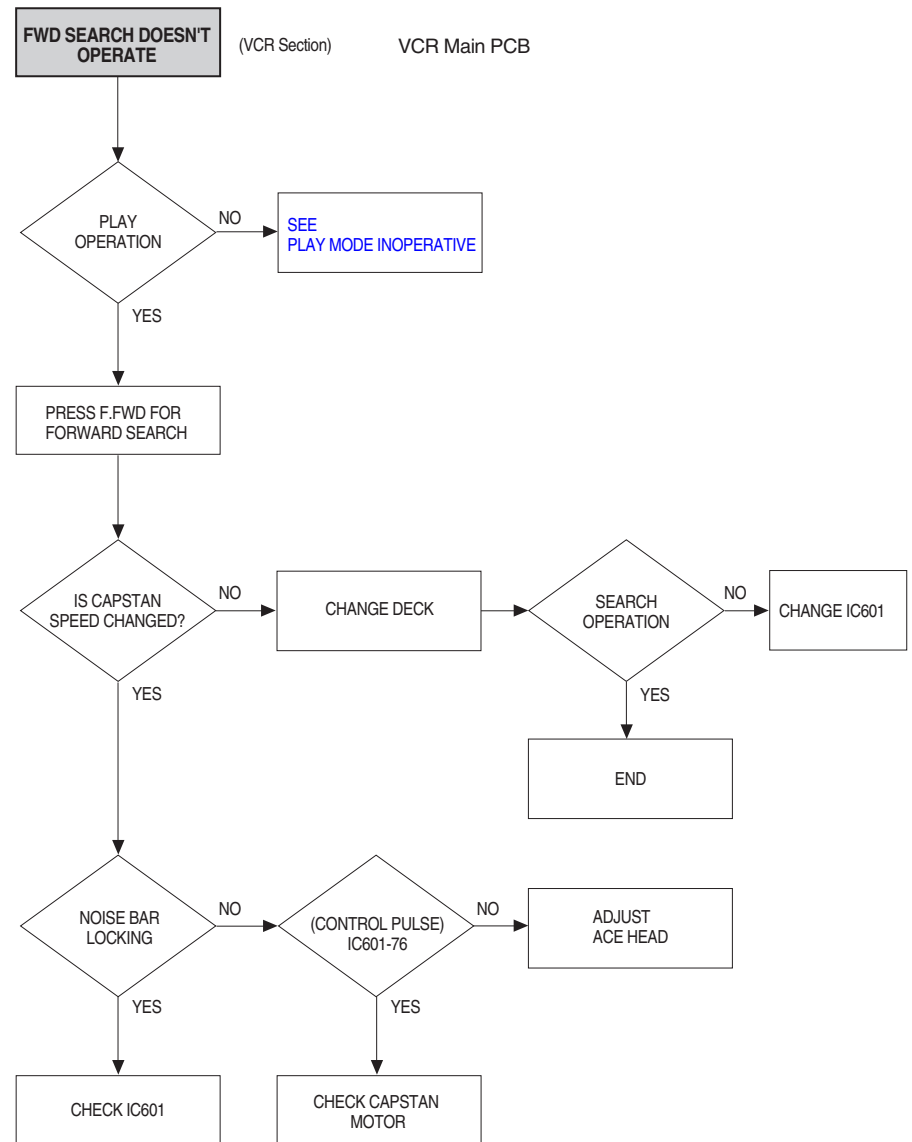
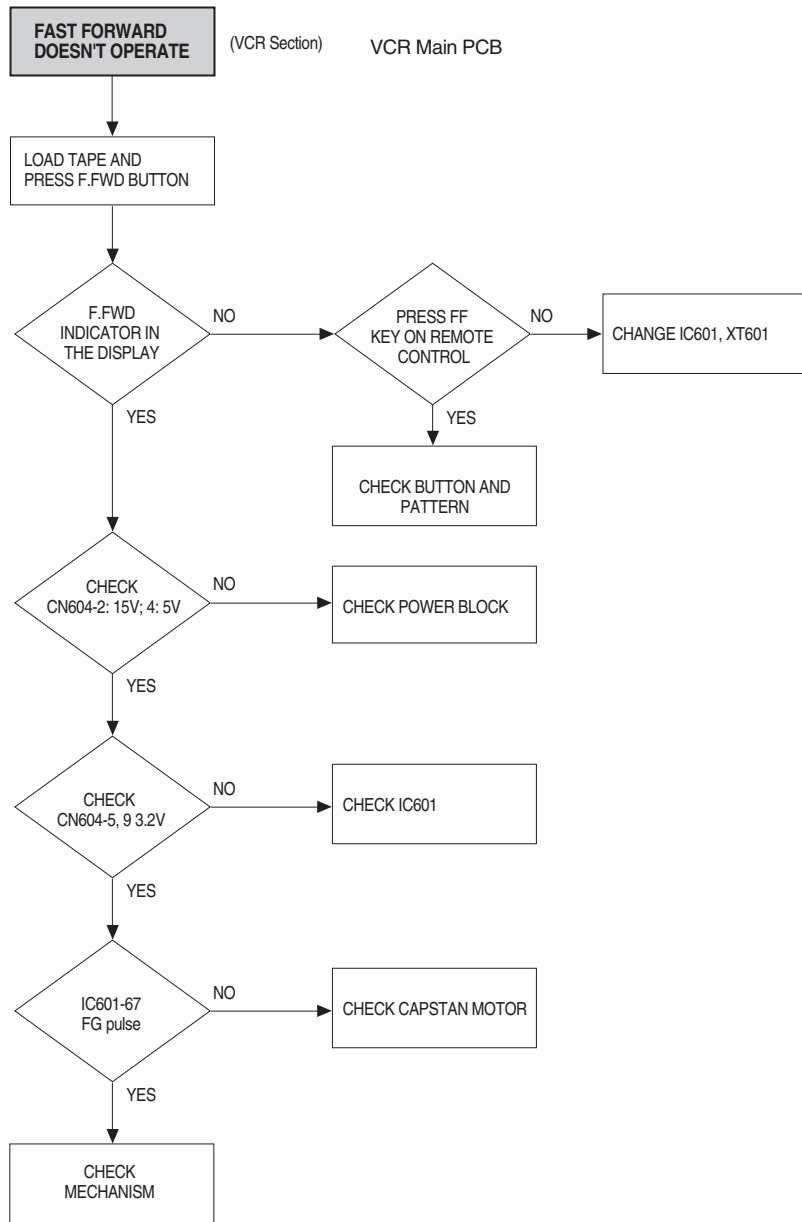

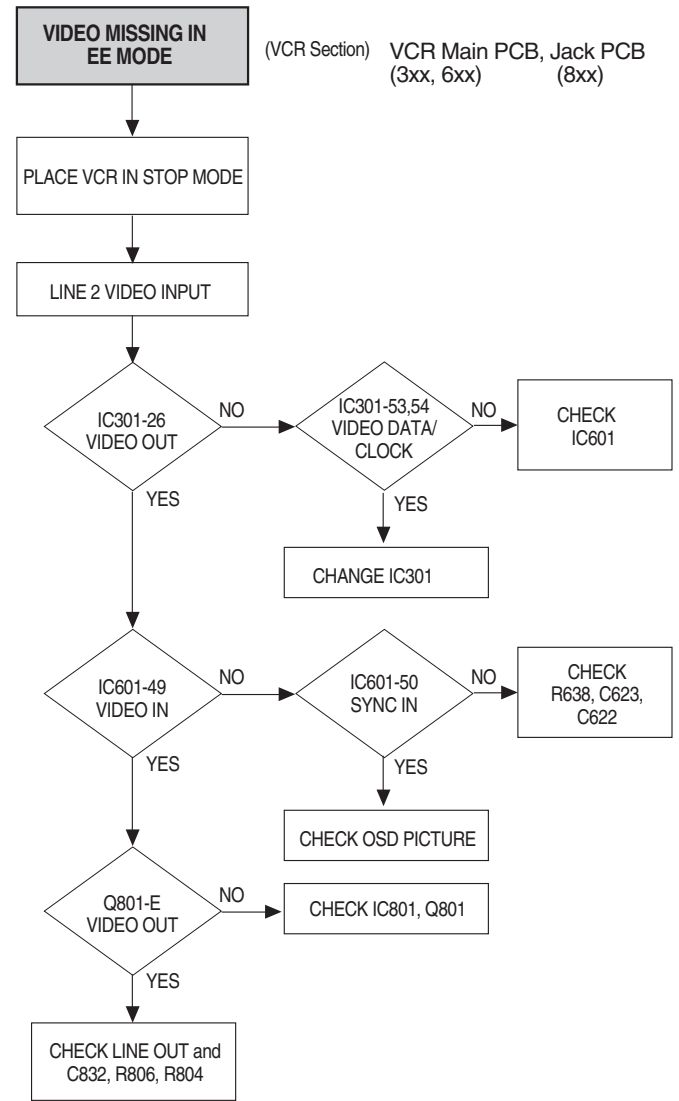
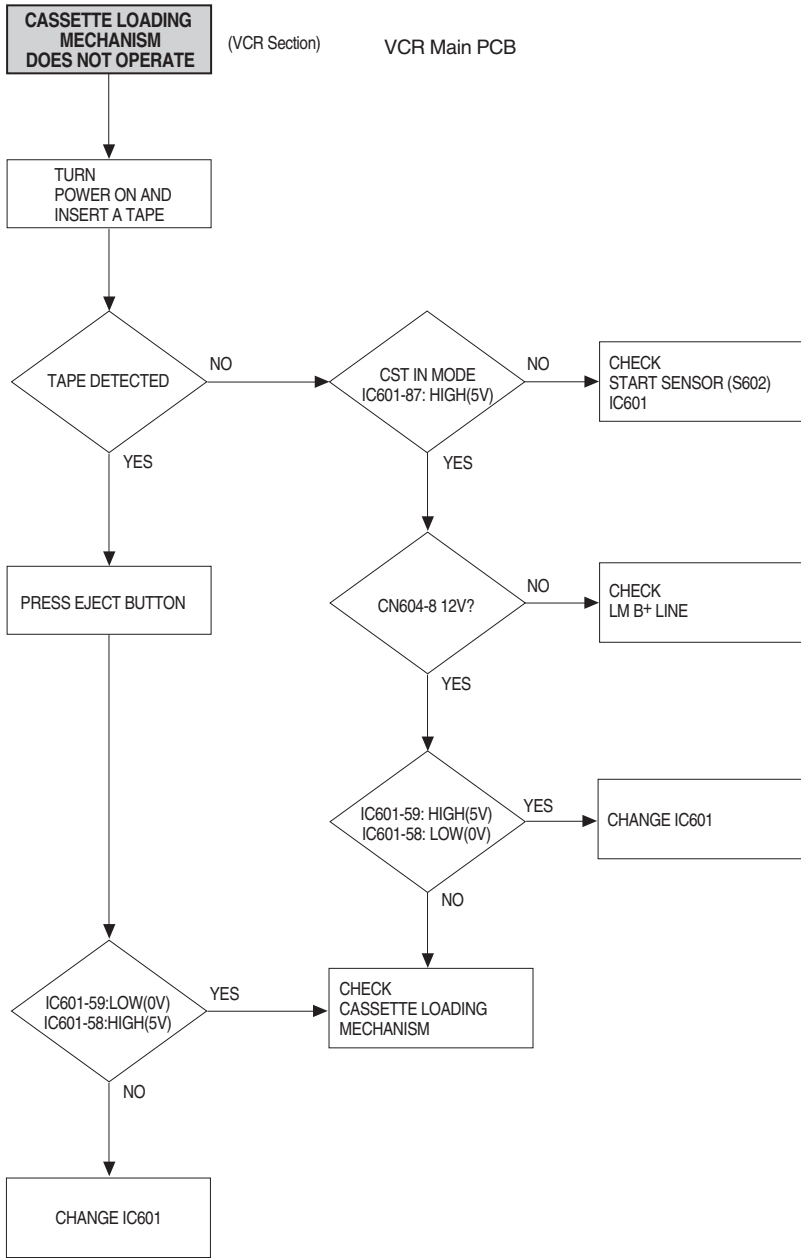

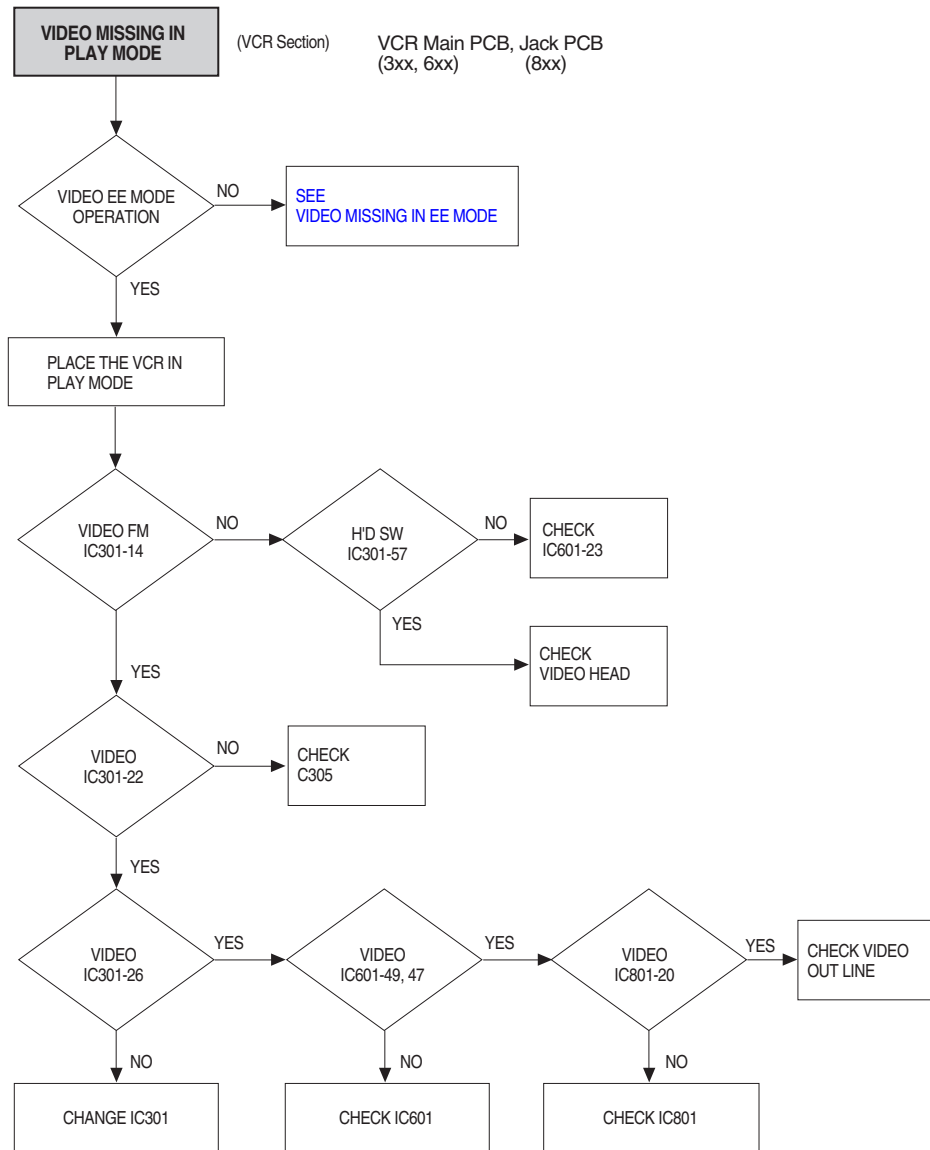
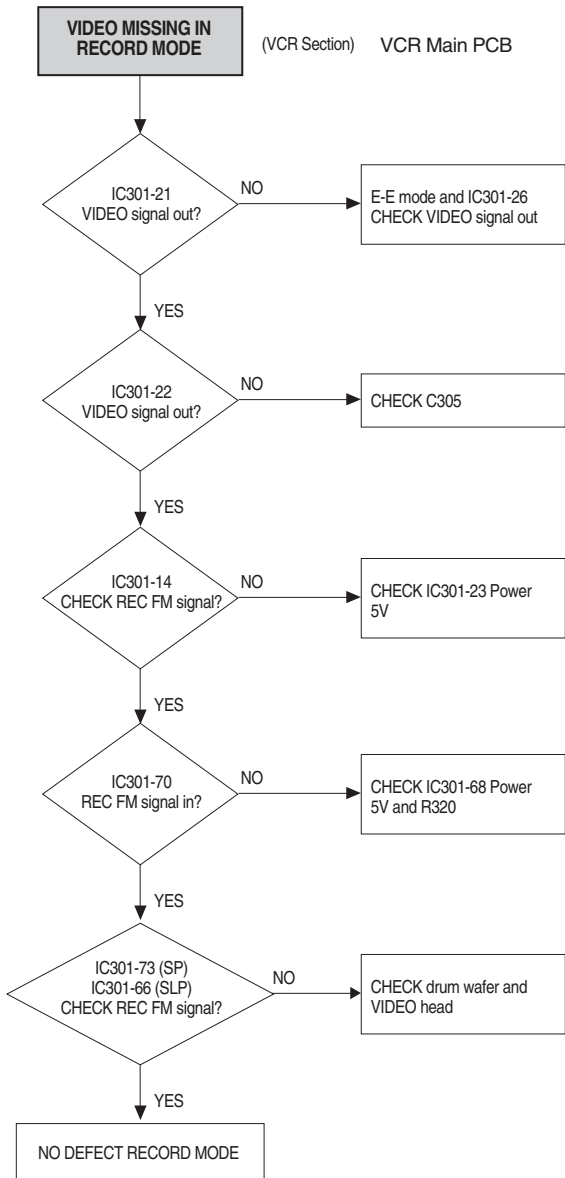

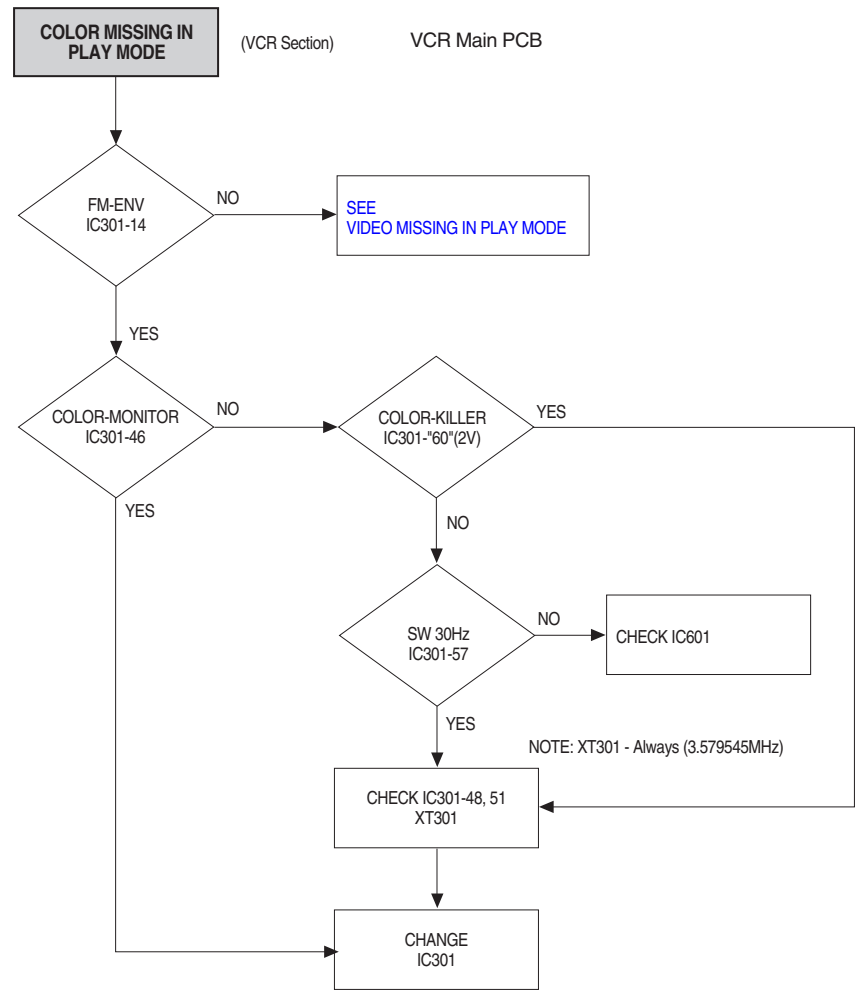
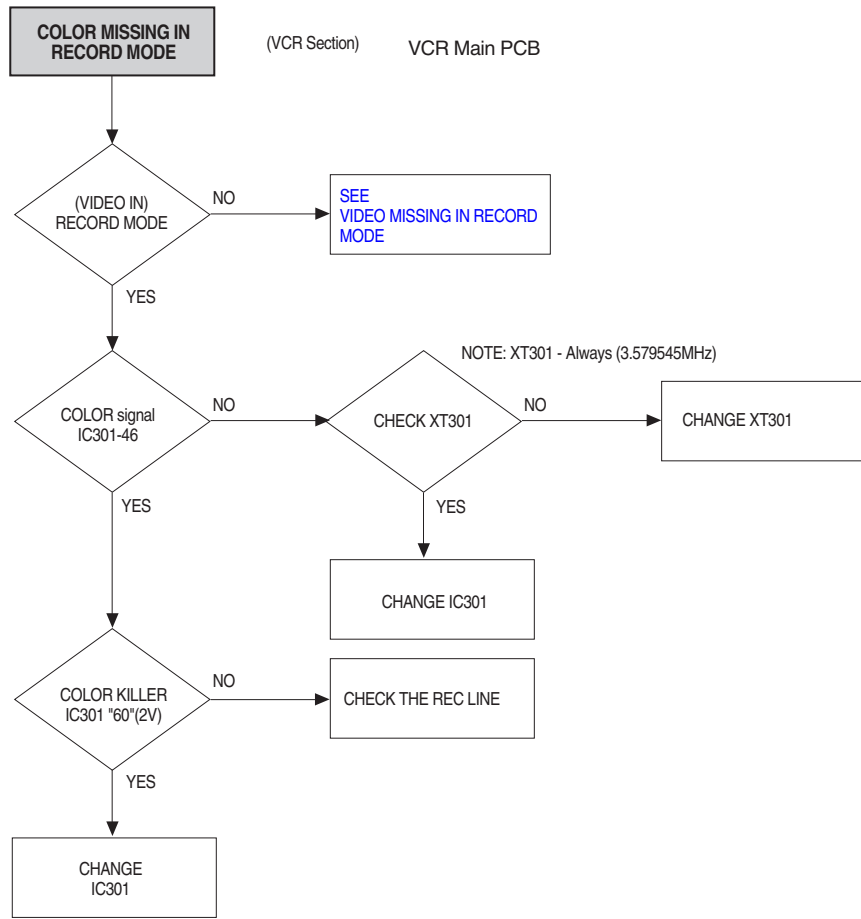

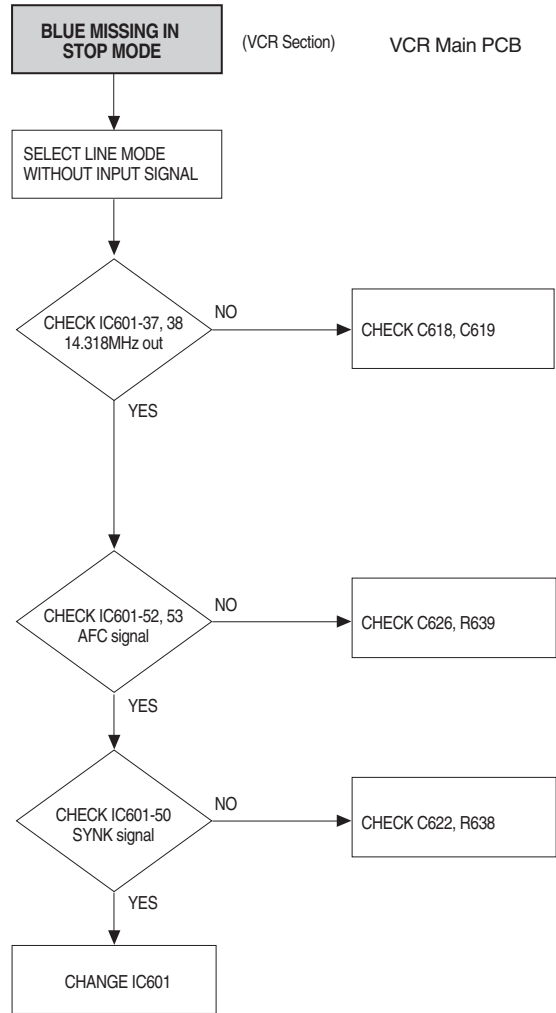
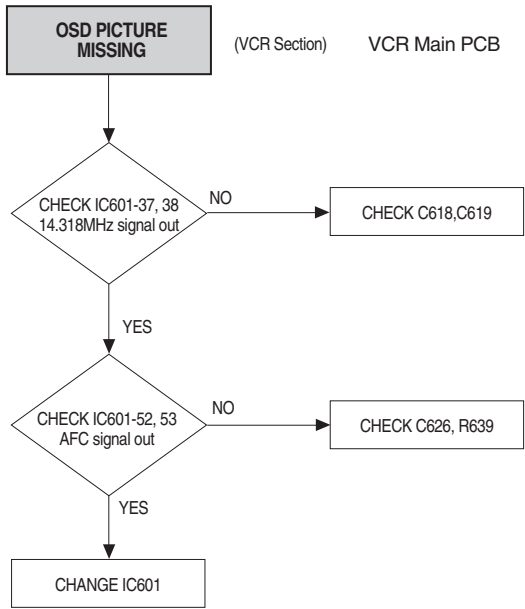

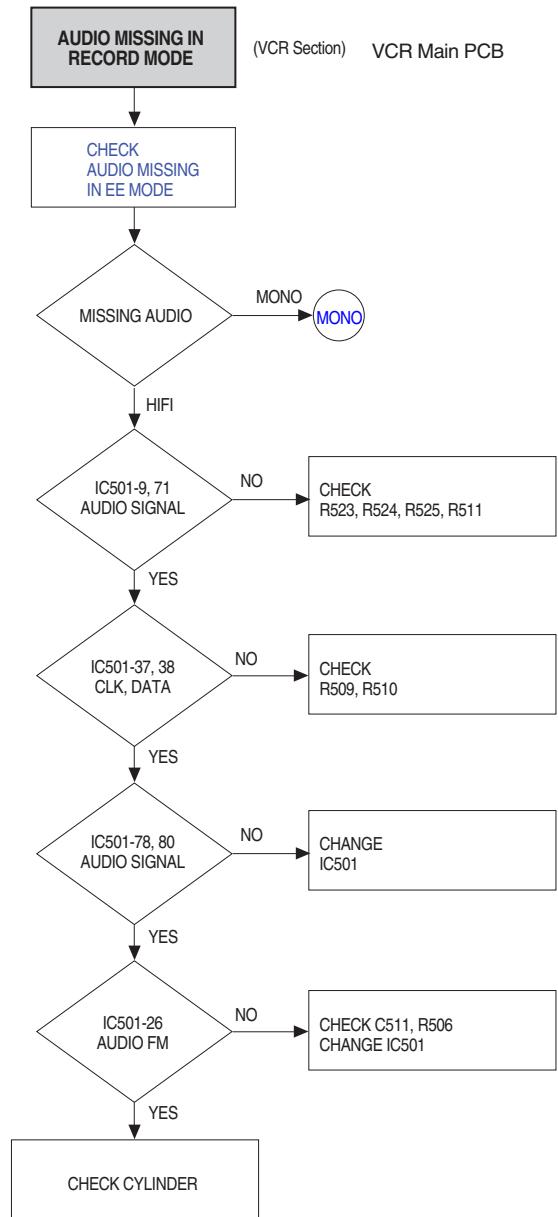
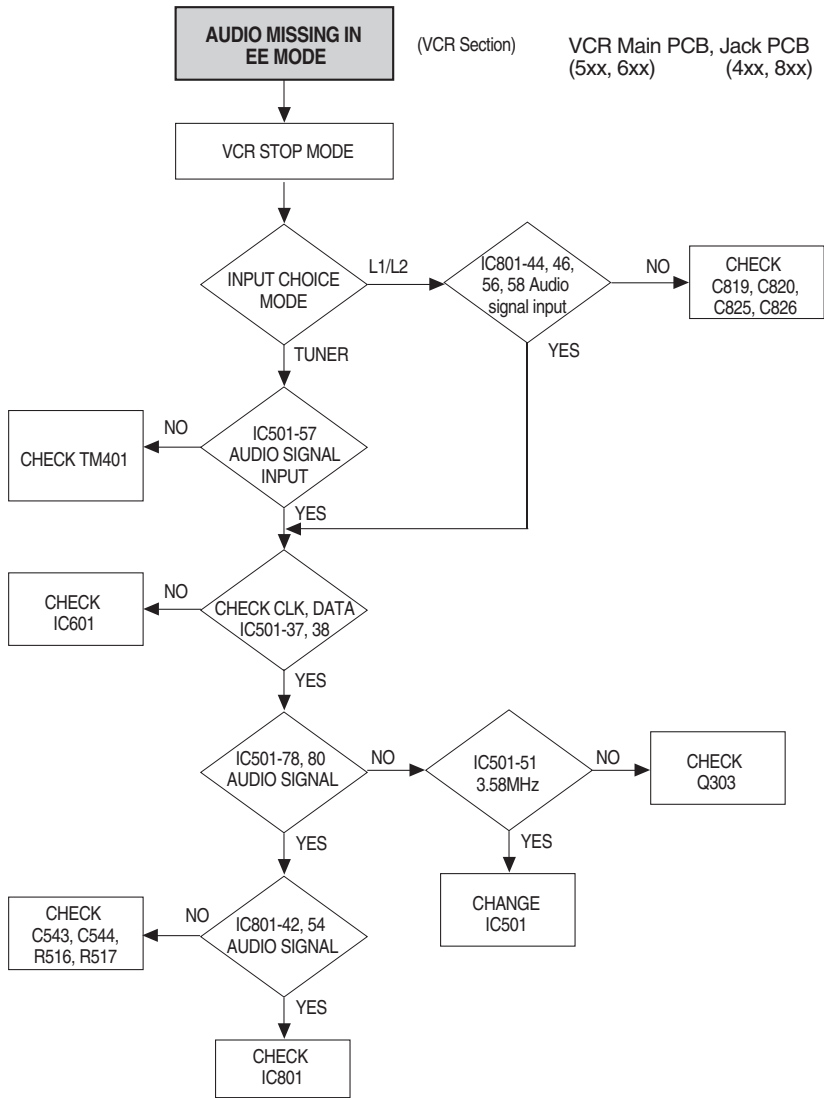

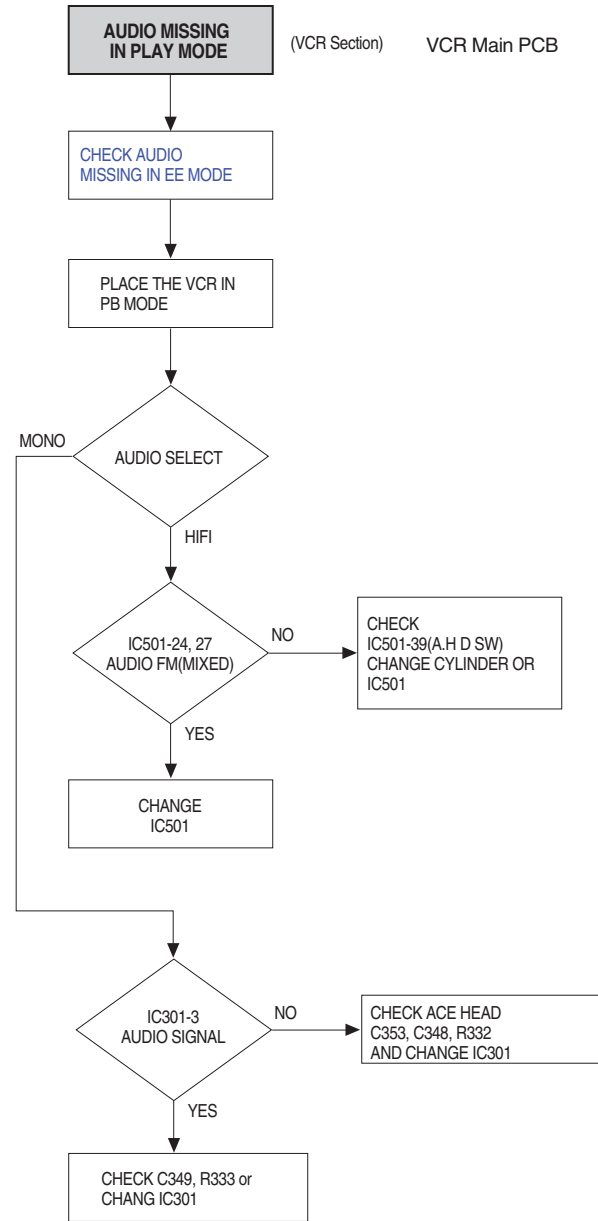
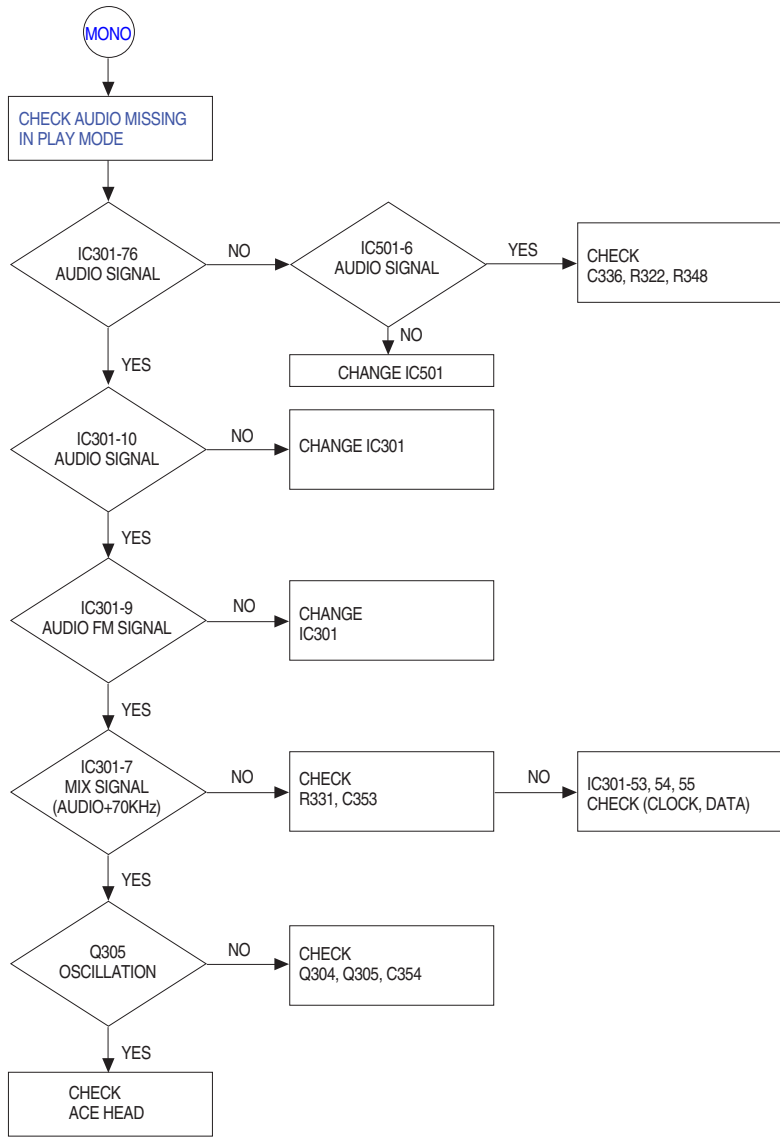

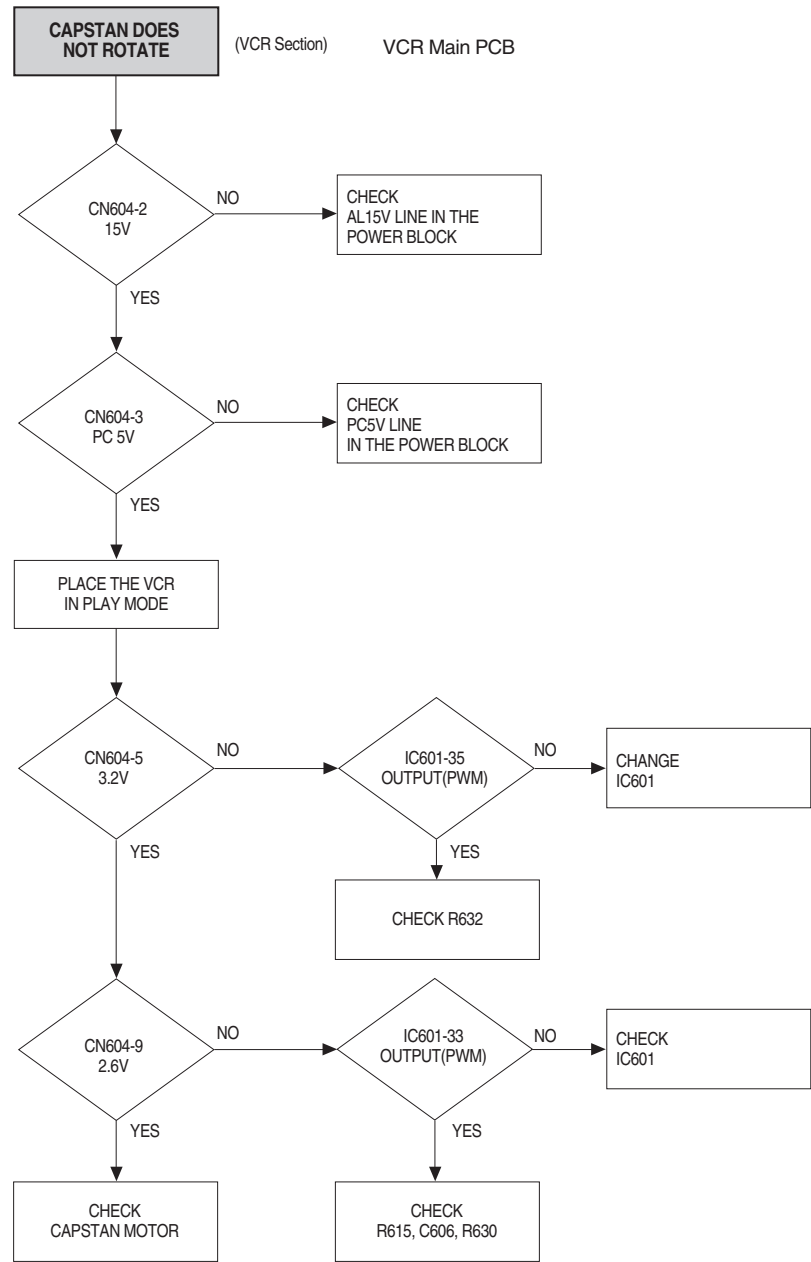
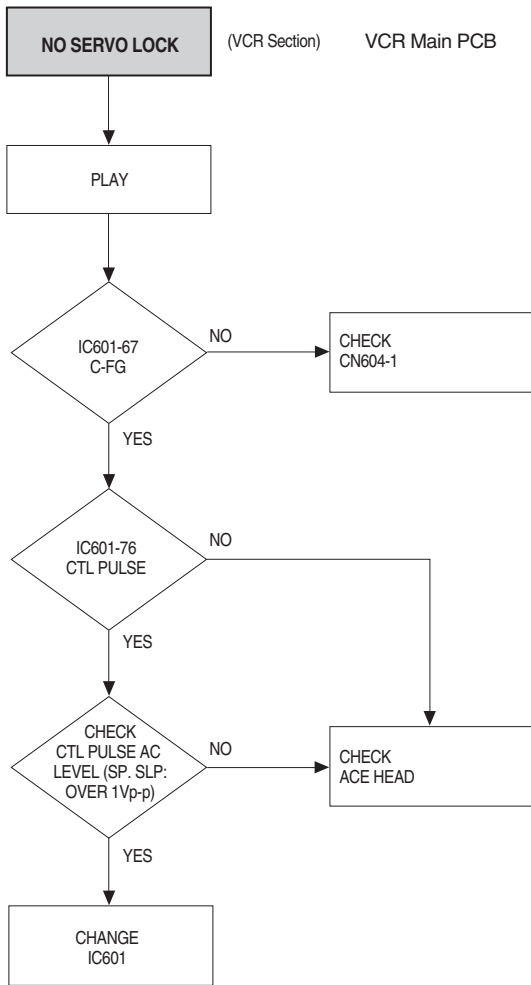

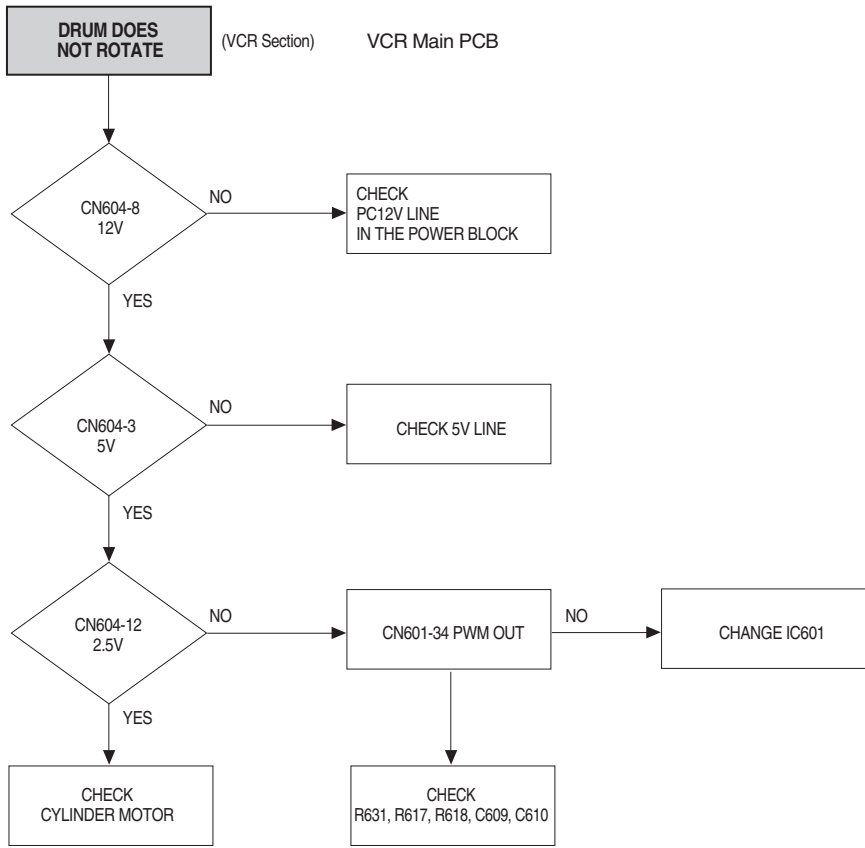

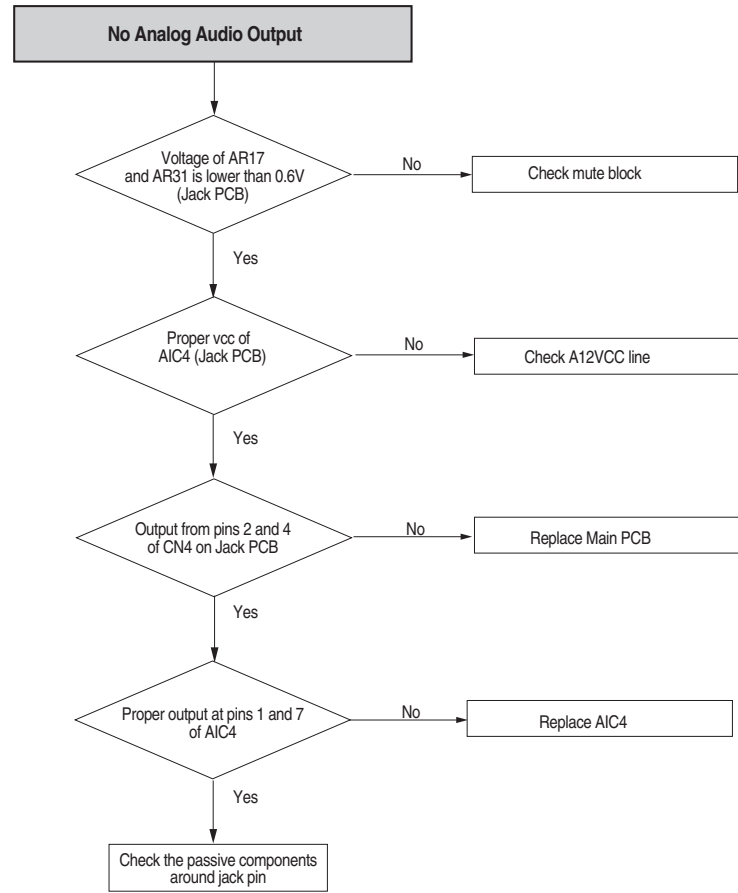
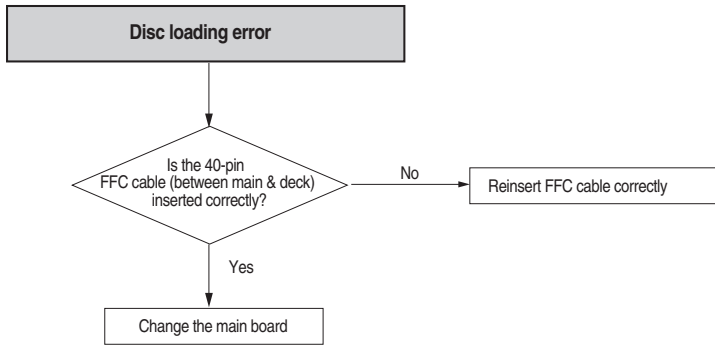
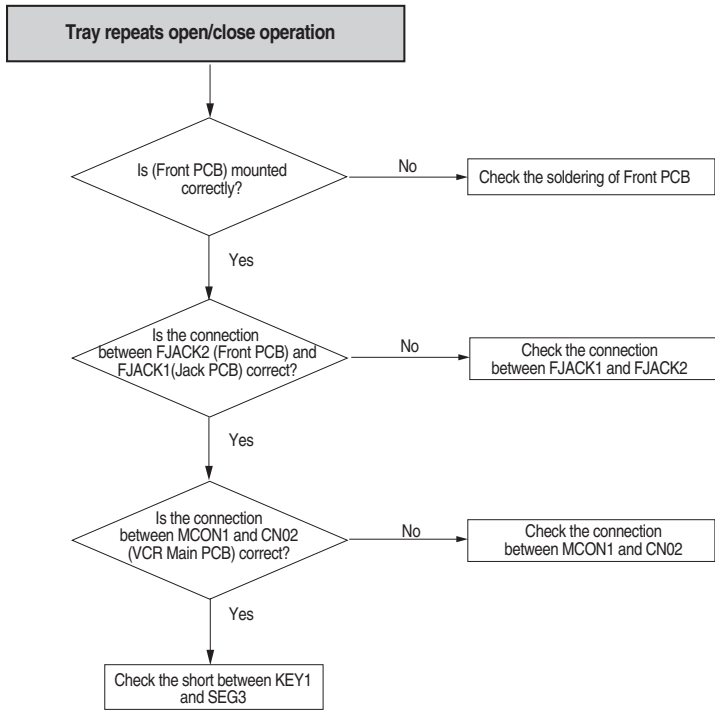

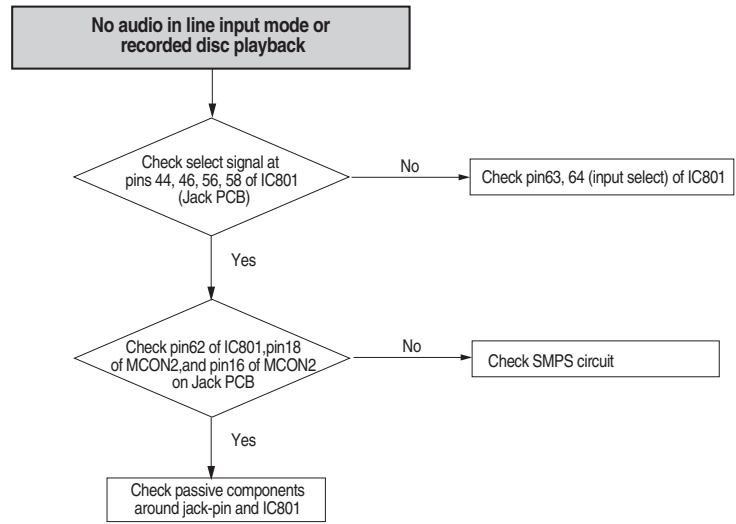
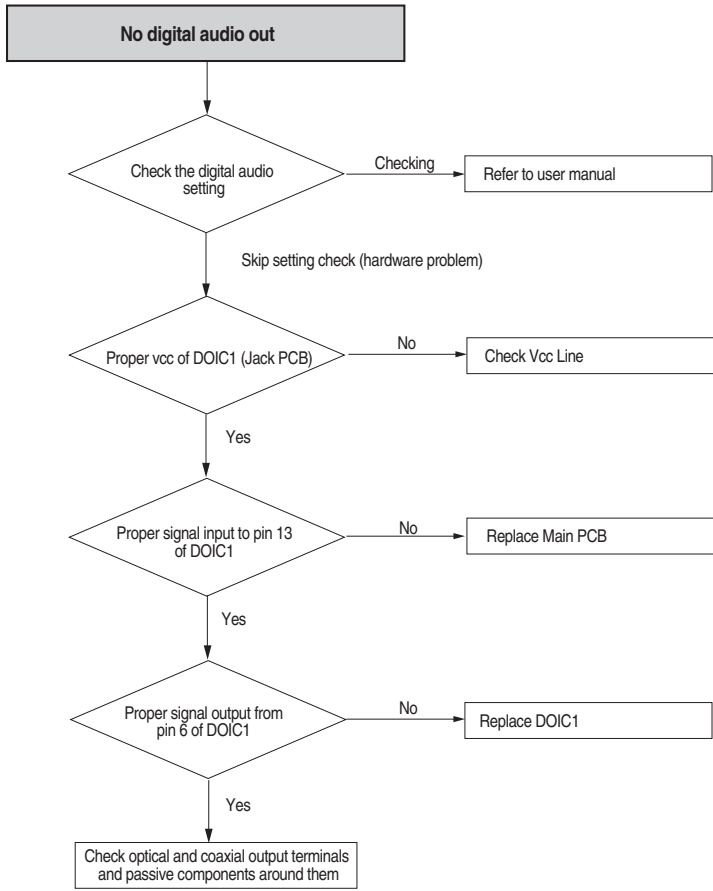

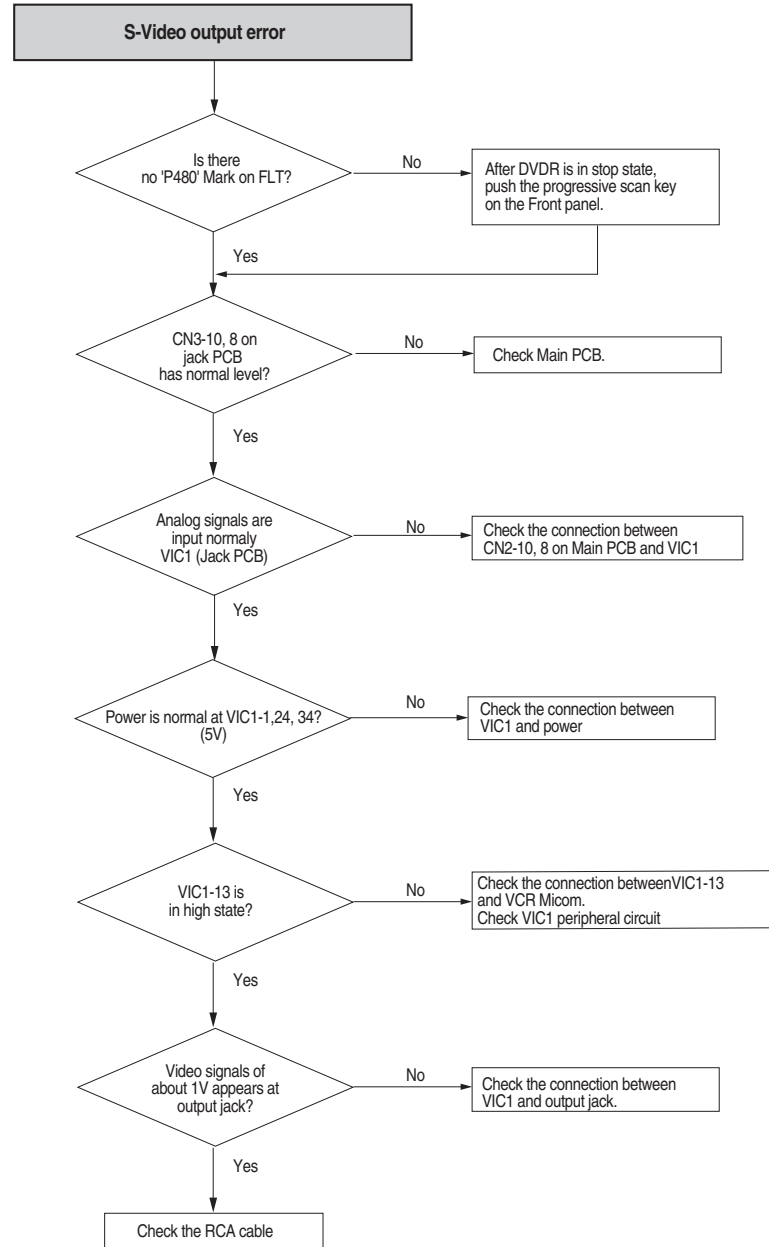
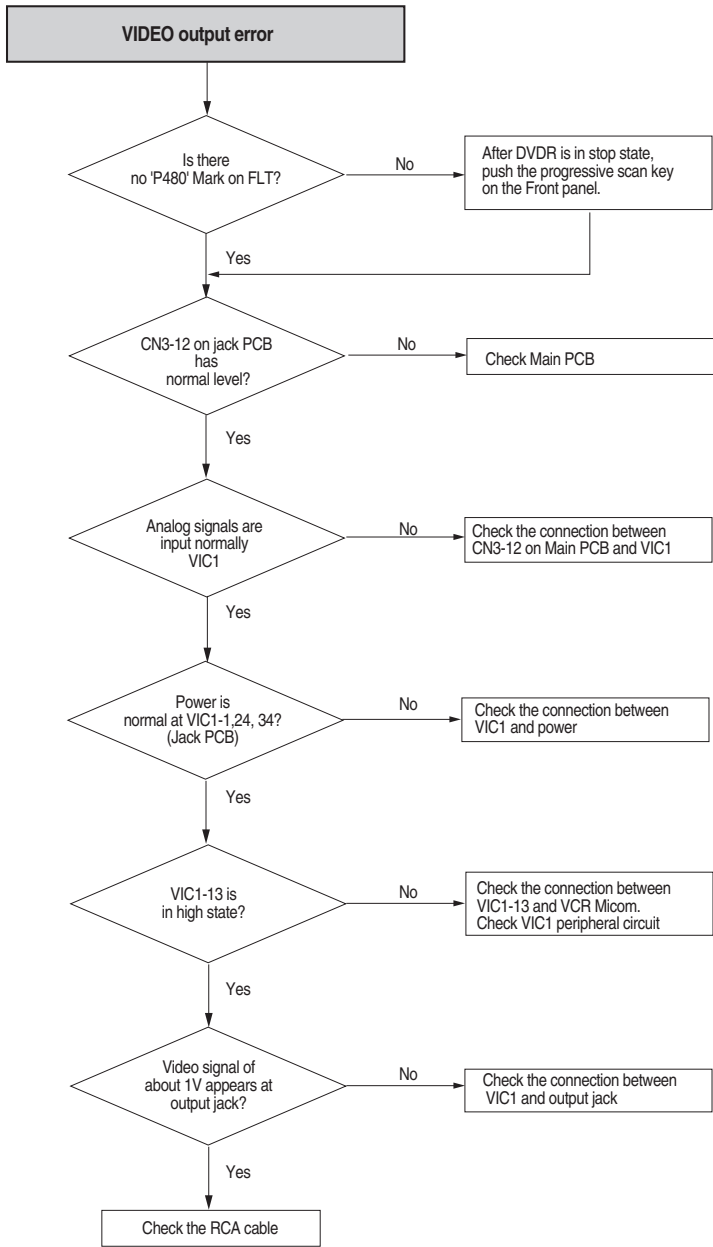

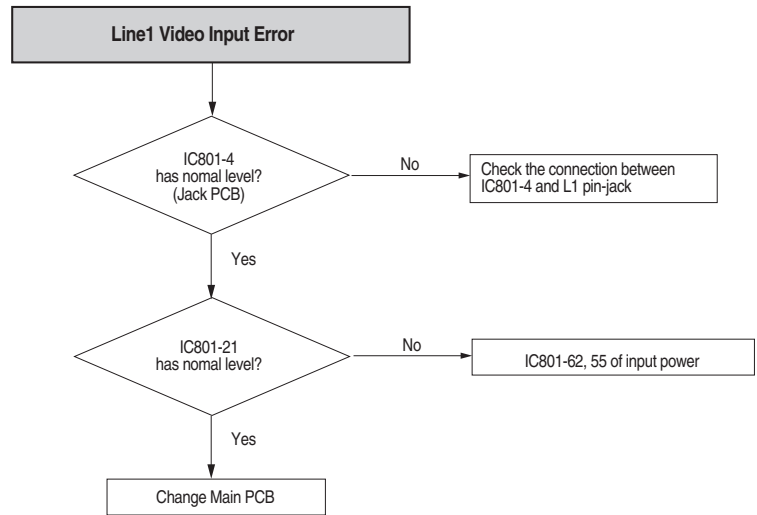
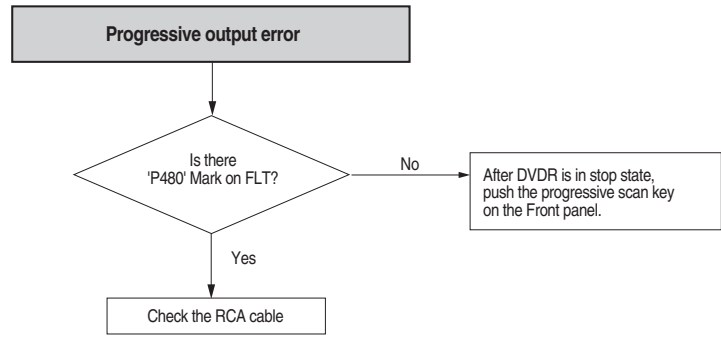
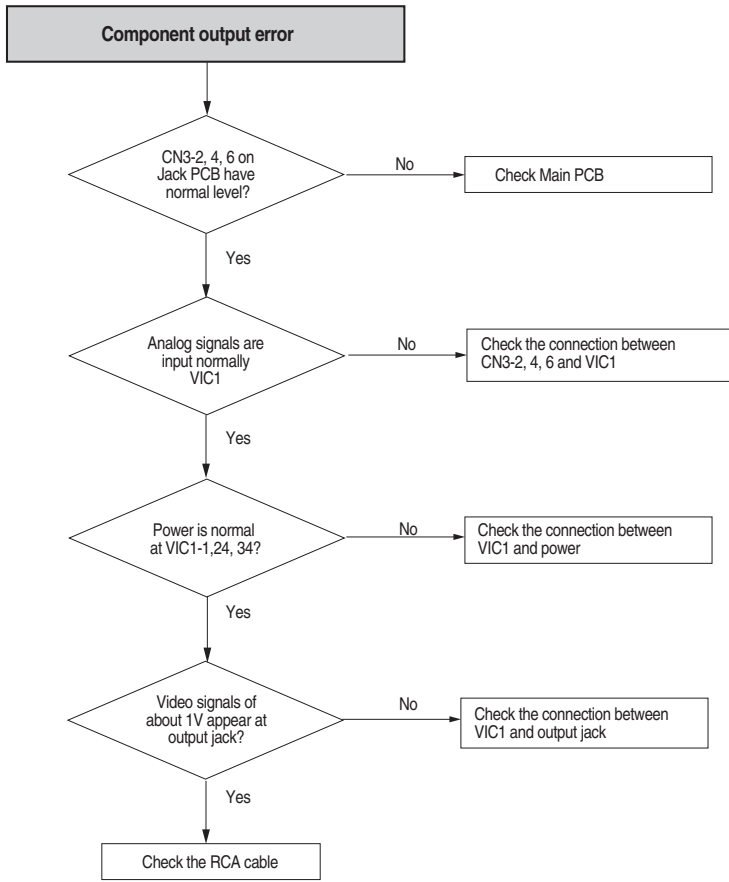

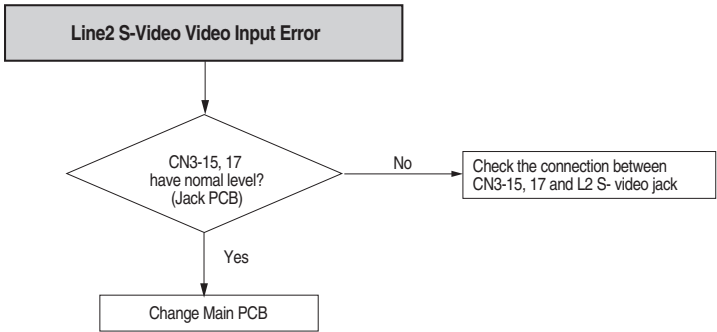
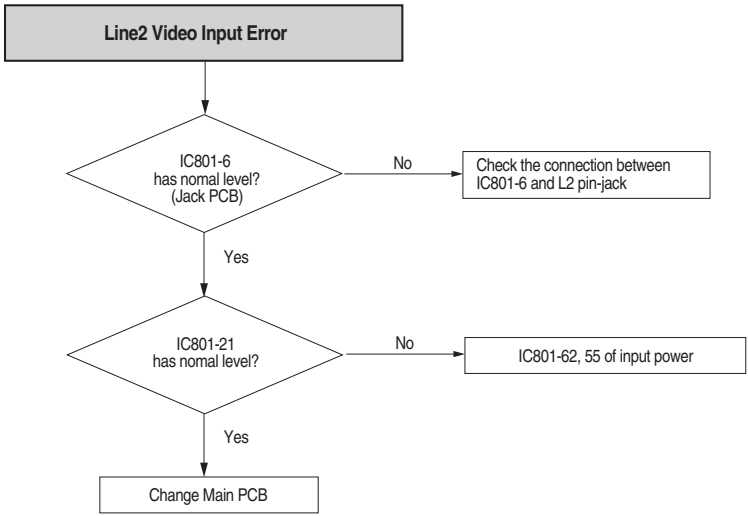

4-1 Order of Disassembly

Refer to the Disassembly Flowchart in Fig. 4-1-1 for the order of removing components. When reassembling components, use the reverse order to removal unless otherwise specified.

Reading Disassembly Flowchart:

After locating the target component in the flowchart, remove all components of the target in sequence, following the arrows (routes) from the top of flowchart. If multiple routes exist to the target component from the top of flowchart, remove all the components on all the routes.

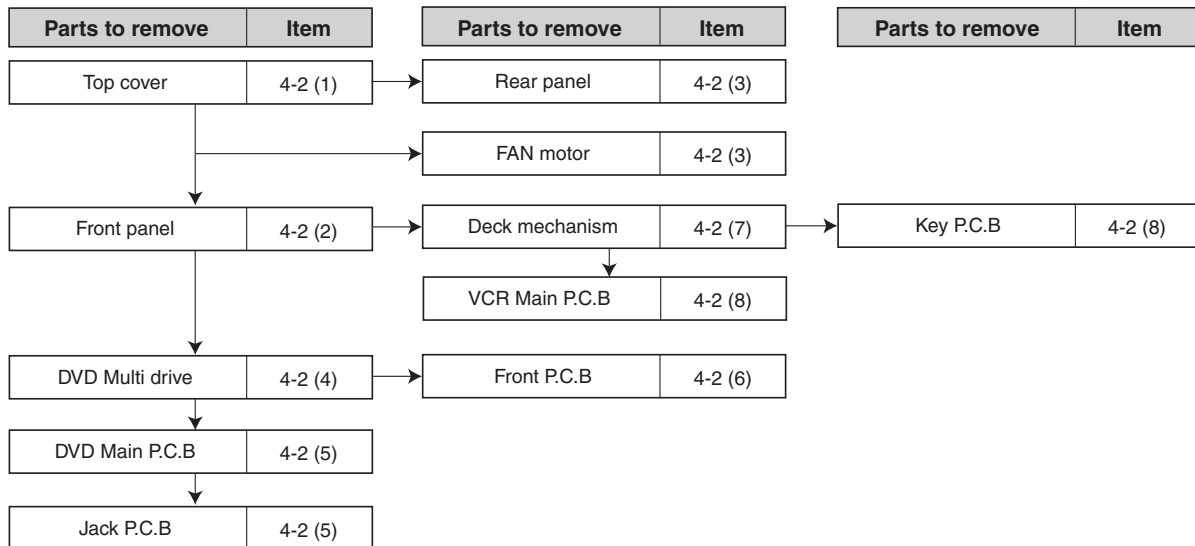

Fig. 4-1-1 Disassembly Flowchart

4-2 Cabinet Disassembly

Information:

Numbers in figures are step numbers in disassembly procedure, and letters in brackets [] show the types of screw.

(1) Top Cover

- 1) Remove the 7 screws [A].
- 2) Slightly open both ends on the front side of top cover and lift the top cover in the direction of the arrow.

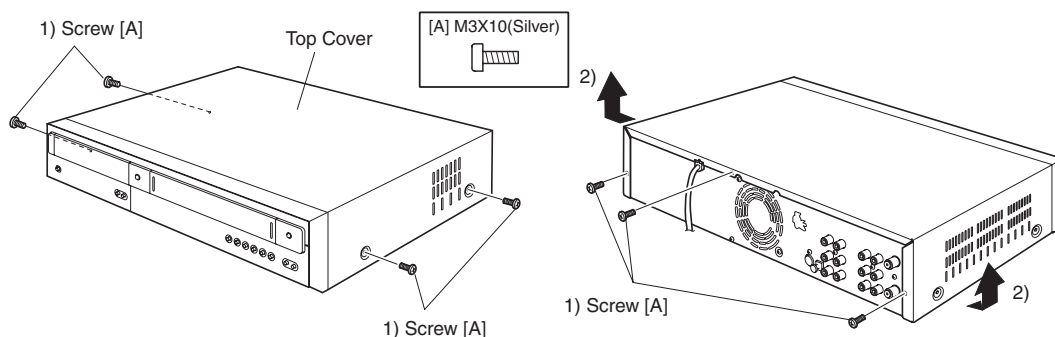

Fig. 4-2-1 Top cover

(2) Front Panel

- 1) Release 3 tabs (A) and 3 tabs (B) in this order. (The tab (A) and the tab (B) should be release at the same time, respectively.)
- 2) Slowly move the front panel forward to remove it.

Caution when reassembling front panel:

Reattach the front panel while pushing the cassette door so that the cassette door open/close lever is positioned outside the door.

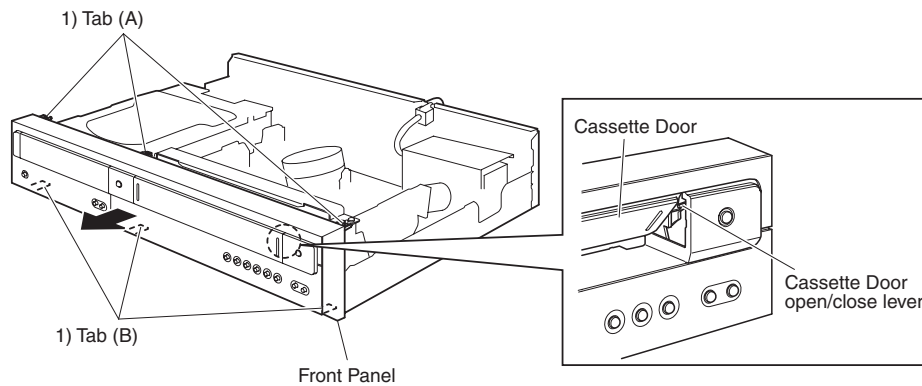

Fig. 4-2-2 Front Panel

(3) Rear Panel and FAN Motor

- 1) Disconnect the power cable.
- 2) Remove 4 screws [B] and the screw [G].
- 3) Disconnect the fan motor connector.
- 4) Release the 2 tabs and remove the rear panel.

When disassembling only FAN motor:

- a) Remove 2 screws [C].
- b) Disconnect the fan motor connector [3) in the figure].

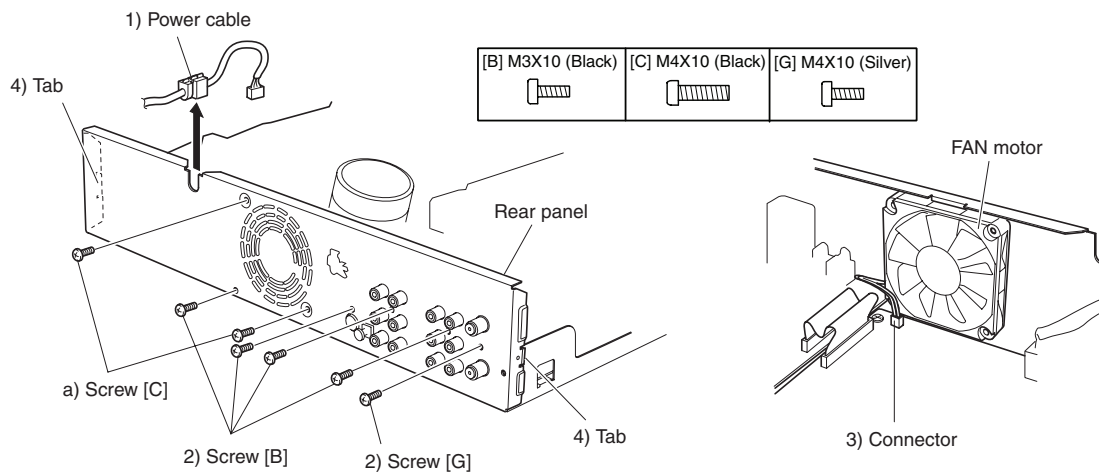

Fig. 4-2-3 Rear Panel and FAN Motor

(4) DVD Multi Drive

- 1) Disconnect the FFC.

*FFC: Flexible flat cable

When reconnecting the FFC, insert it into the connector, following the instructions in illustration, and check the connection status.

- 2) Disconnect the connector.
- 3) Remove 4 screws [D].
- 4) Pull the DVD multi drive out vertically.

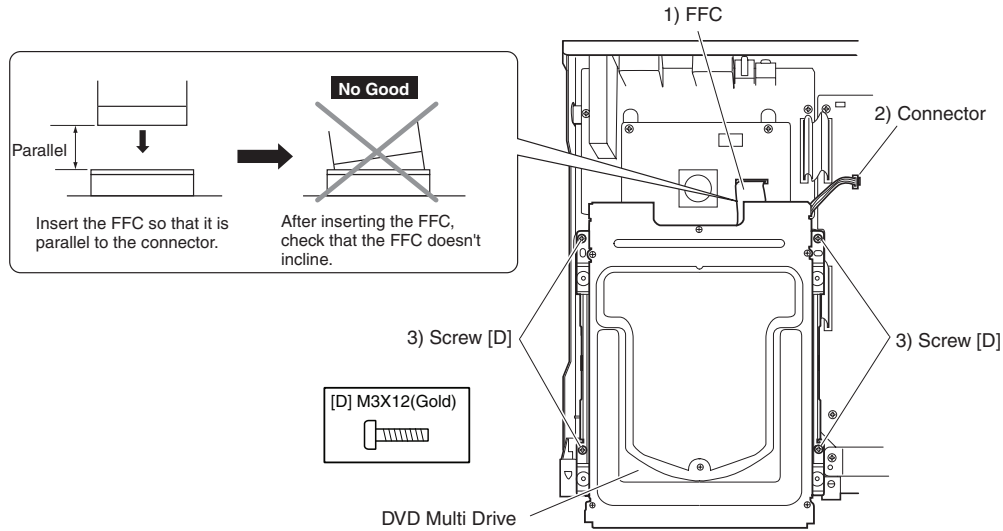

Fig. 4-2-4 DVD Multi Drive

(5) DVD Main P.C.B and Jack P.C.B (Fig. 4-2-5)

- 1) Remove 3 screws [D].
- 2) Pull the DVD Main P.C.B out vertically.

Caution

The 3 direct connectors that connect the DVD Main P.C.B and Jack P.C.B (at the back of DVD Main P.C.B) are tightly locked: Carefully pull out the DVD Main P.C.B.

- 3) Remove the rear panel. (Refer to section (3).)
- 4) Disconnect the 3 FFCs.
When reconnecting the FFCs, insert them into the connectors, following the instructions in illustration, and check the connection status.
- 5) Remove 3 screws [F], and then remove the Jack P.C.B.

(6) Front P.C.B

1) Remove the FFC [portion a) in the figure].

When reconnecting the FFC, insert it into the connector, following the instructions in illustration, and check the connection status.

2) Remove 2 screws [F] [portion b) in the figure], and then remove the Front P.C.B.

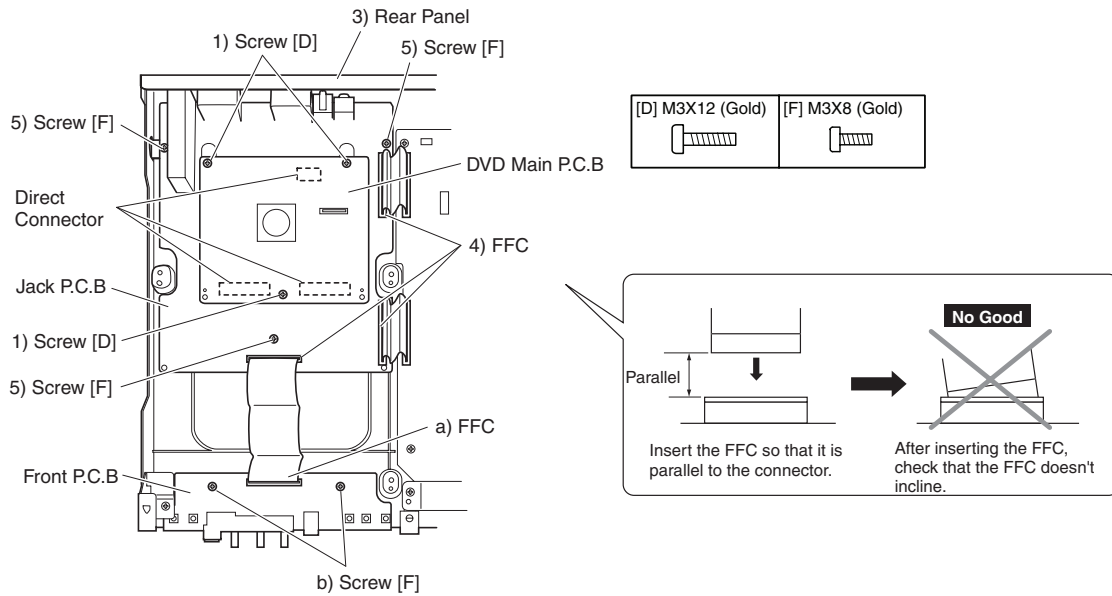

Fig. 4-2-5 DVD Main P.C.B, Jack P.C.B and Front P.C.B

(7) Deck Mechanism

1) Remove 2 screws [D], and then remove the guide holder.

2) Disconnect the ACE head connector.

3) Remove 4 screws [E].

4) While unplugging the 3 direct connectors that connect the deck mechanism and VCR Main P.C.B, lift the entire deck mechanism vertically.

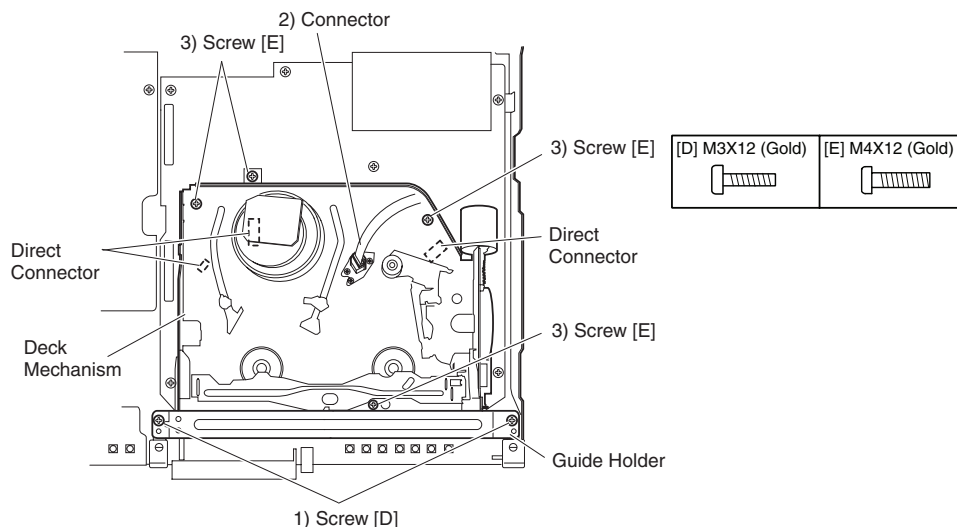

Fig. 4-2-6 Deck Mechanism

Cautions when reassembling deck mechanism

Check the following when reassembling the deck mechanism:

- Set the boss of the mode switch (SW603) on VCR Main P.C.B to the position shown in the figure below.
- Make sure that joint 1 gear on the back of deck mechanism is in the position shown in the figure below.

When the deck mechanism is properly reassembled at right angles, the boss of mode switch can be inserted into the hole in joint 1 gear.

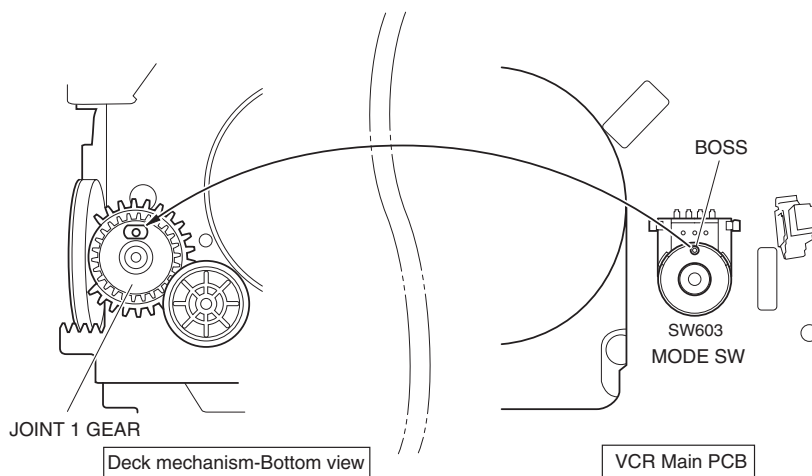

Fig. 4-2-7 Reassembling Deck Mechanism

(8) Key P.C.B and VCR Main P.C.B

- 1) Remove screw [F].
- 2) Unplug the direct connector from VCR Main P.C.B, and then remove the Key P.C.B.
- 3) Disconnect the 2 FFCs.

When reconnecting the FFCs, insert them into the connectors, following the instructions in illustration, and check the connection status.

- 4) Remove 6 screws [F], and then remove the VCR Main P.C.B.

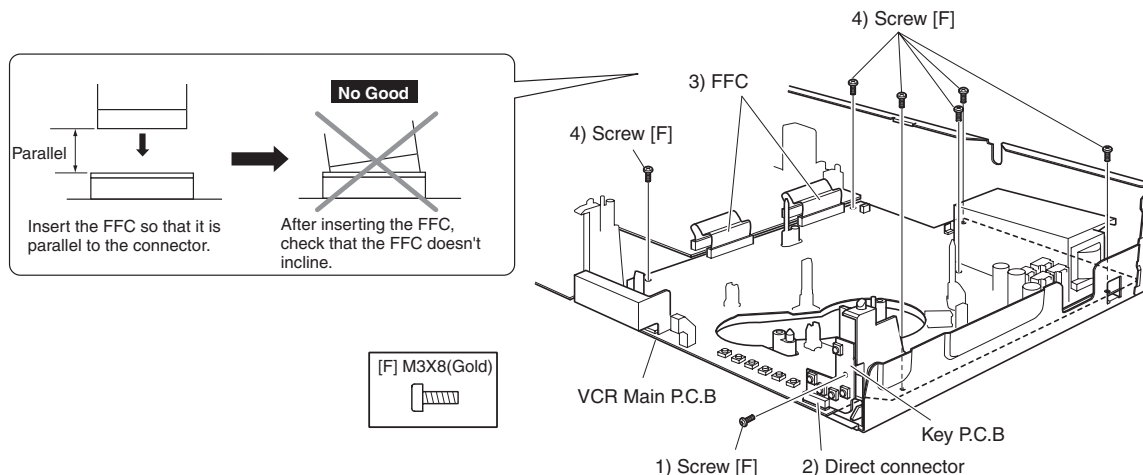

Fig. 4-2-8 Key P.C.B and VCR Main P.C.B

4-3 VCR Deck Parts Locations

4-3-1 Top View

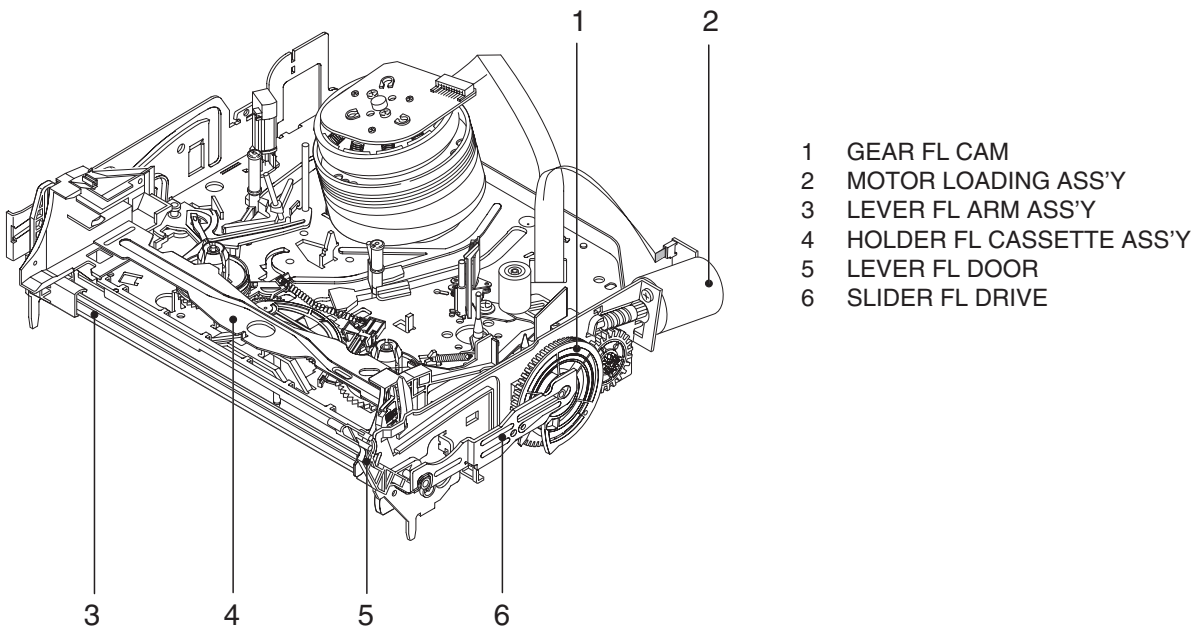

Fig. 4-3-1 Top View of parts Locations-1

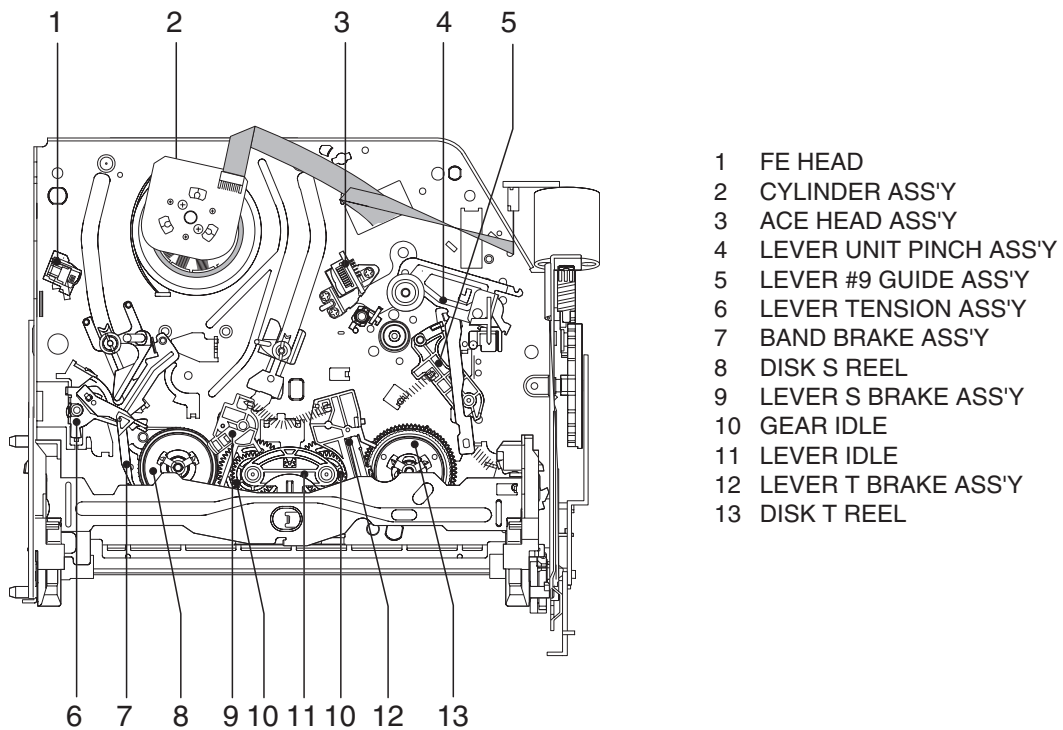

Fig. 4-3-2 Top View of Parts Locations-2

4-3-2 Bottom View

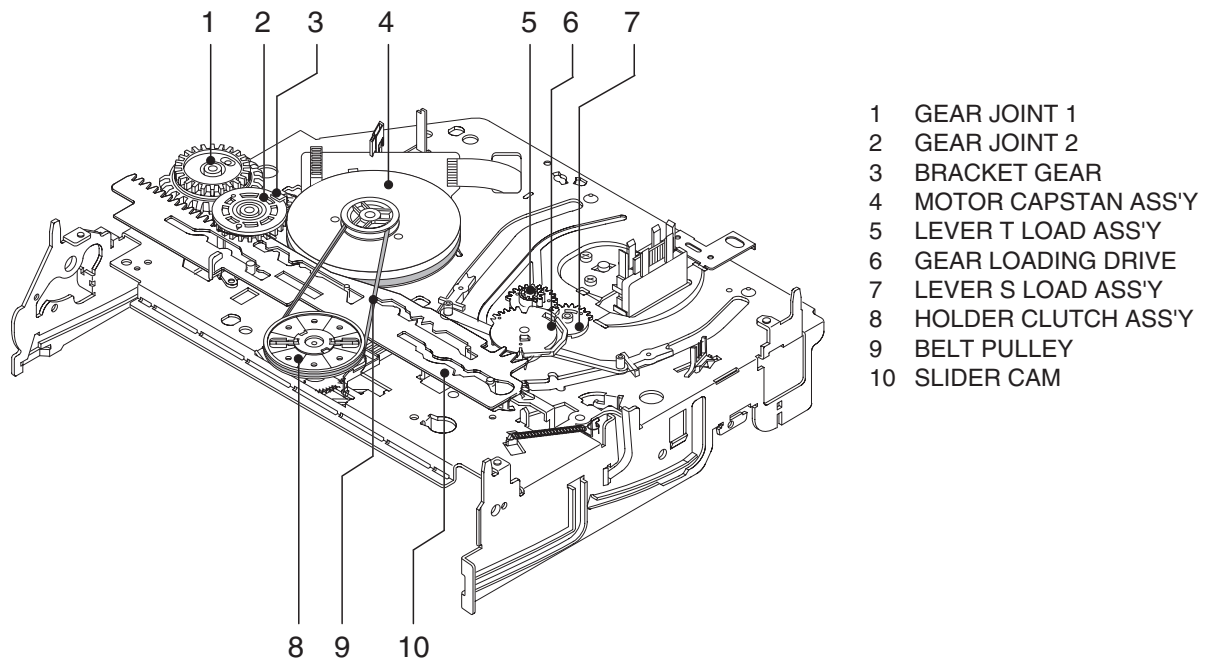

Fig. 4-3-3 Bottom View of Parts Locations

4-4 VCR Deck Mechanism Disassembly

(1) Holder FL Cassette Ass'y Removal

- 1) Pull the Holder FL Cassette Ass'y to the eject position.
- 2) Pull the Holder FL Cassette Ass'y by holding the Holder FL Cassette Ass'y and Lever FL Cassette-R at the same time to release hooking from Main Base until Boss [A] of Holder FL Cassette Ass'y is removed from Rail [B].
- 3) Lift the Holder FL Cassette Ass'y at this time: You have to hold the Lever FL Cassette-R continuously until the Holder FL Cassette Ass'y is removed completely.

Note:

Be sure to insert Lever FL Cassette-R in the direction of "A" to prevent separation and breakage of the Lever FL Cassette-R during disassembly and reassembly.

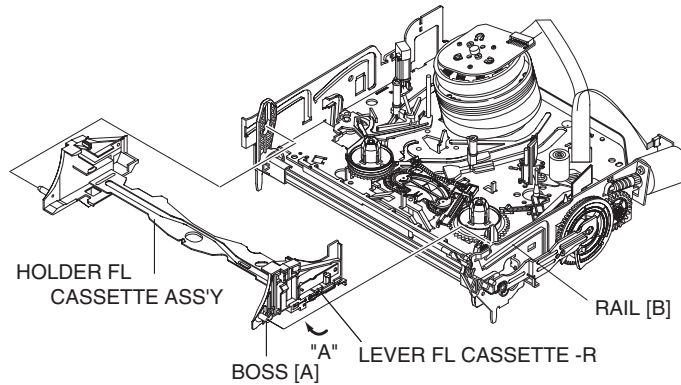

Fig. 4-4-1 Holder FL Cassette Ass'y Removal

(2) Lever FL Arm Ass'y Removal

- 1) Push hole "A" in the direction of arrow "B" using a pin.
- 2) Pull out the Lever FL Arm Ass'y from the Boss of Main Base.
- 3) Remove the Lever FL Arm Ass'y in the direction of arrow "C".

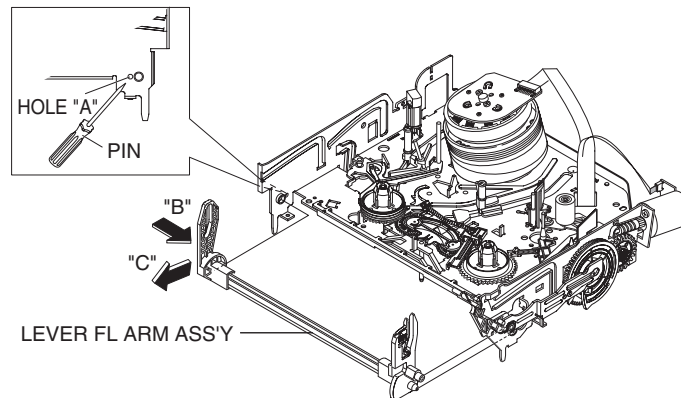

Fig. 4-4-2 Lever FL Arm Ass'y Removal

(3) Lever FL Door Removal

- 1) Remove the Slider FL Drive in the direction of arrow.
- 2) Release the Hook and Remove the Lever FL Door in the direction of arrow "B".

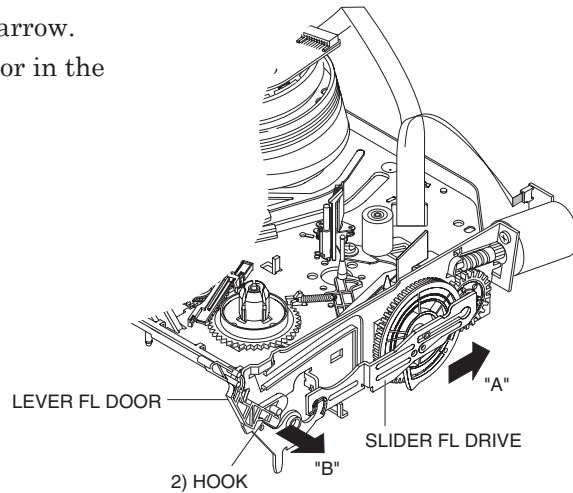

Fig. 4-4-3 Lever FL Door Removal

(4) Slider FL Drive, Gear FL Cam Removal

- 1) Pull the Slider FL Drive to the front.
- 2) Remove the Gear FL cam.

Note :

When reinstalling, be sure to reassemble the Slider FL Drive after inserting the Boss of Lever FL ARM into the Groove in Slider FL Drive.

Assembly :

Align the Gear FL Cam with the Gear Worm Wheel Post as shown. (Refer to Timing point)

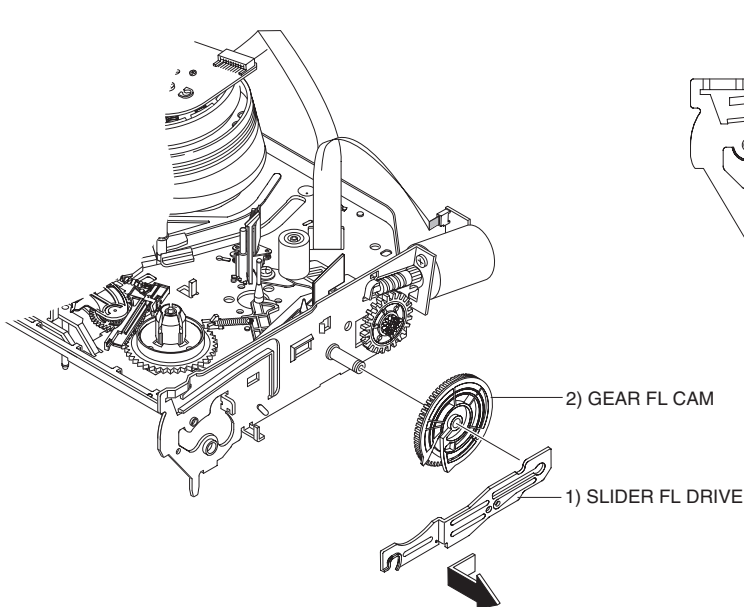

Fig. 4-4-4 Slider FL Drive Removal

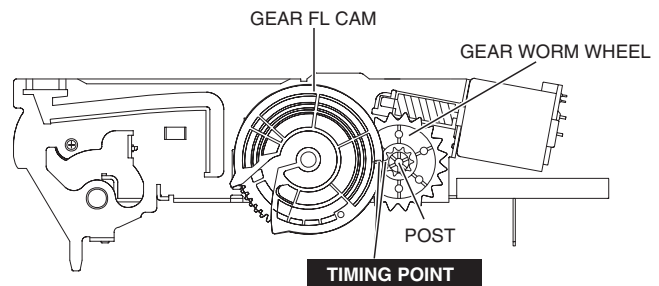

Fig. 4-4-5 Gear FL Cam, Gear Worm

(5) Gear Worm Wheel Removal

- 1) Remove the Gear Worm Wheel.

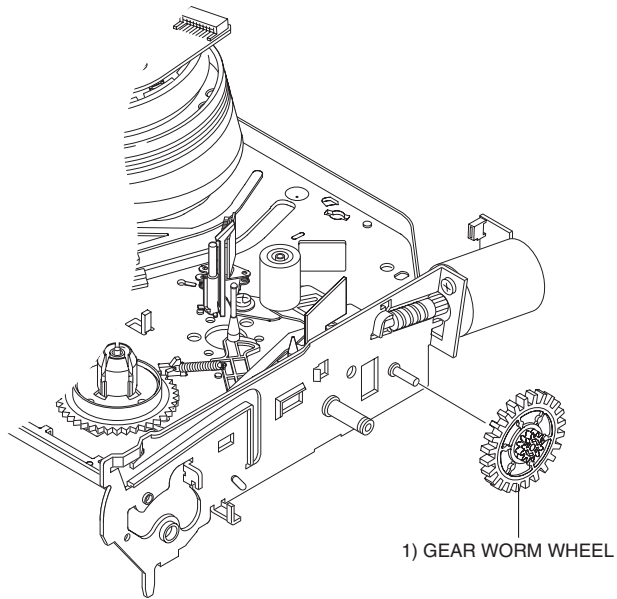

Fig. 4-4-6 Gear Worm Wheel Removal

(6) Cable Flat Removal

- 1) Remove the Drum connecting part of Cable Flat from the Connector Wafer.
- 2) Remove the Loading Motor connecting part of Cable Flat from the Connector Wafer.

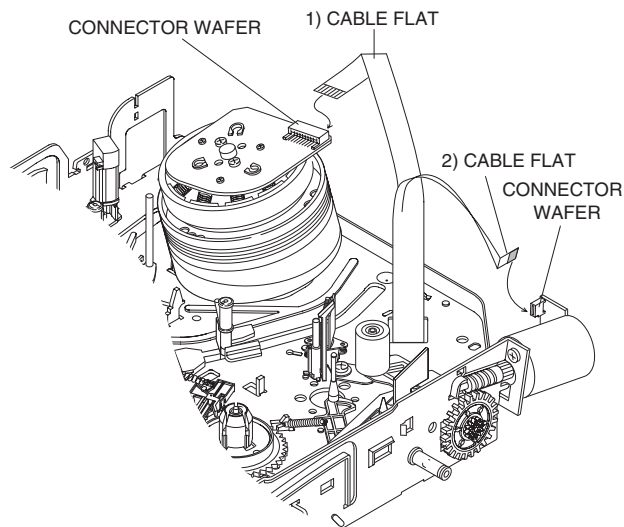

Fig. 4-4-7 Cable Flat Removal

(7) Motor Loading Ass'y Removal

- 1) Remove the screw.
- 2) Remove the Motor Loading Ass'y.

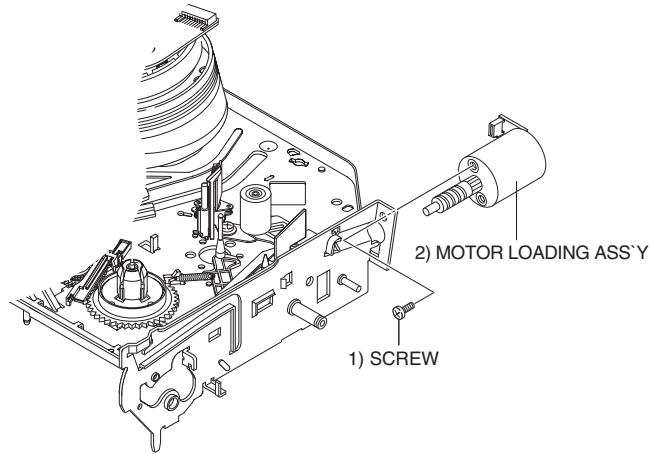

Fig.4-4-8 Motor Loading Ass'y Removal

(8) Bracket Gear, Gear Joints 2, 1 Removal

- 1) Remove the screw.
- 2) Remove the Bracket Gear.
- 3) Remove Gear Joint 2.
- 4) Remove Gear Joint 1.

Assembly :

- 1) Be sure to align the dot mark of Gear Joint 1 with the dot mark of Gear Joint 2 as shown in Fig 4-4-10. (Refer to Timing Point 1)
- 2) Confirm Timing Point 2 of Gear Joint 2 and Slider Cam. (Refer to Timing Point 2)

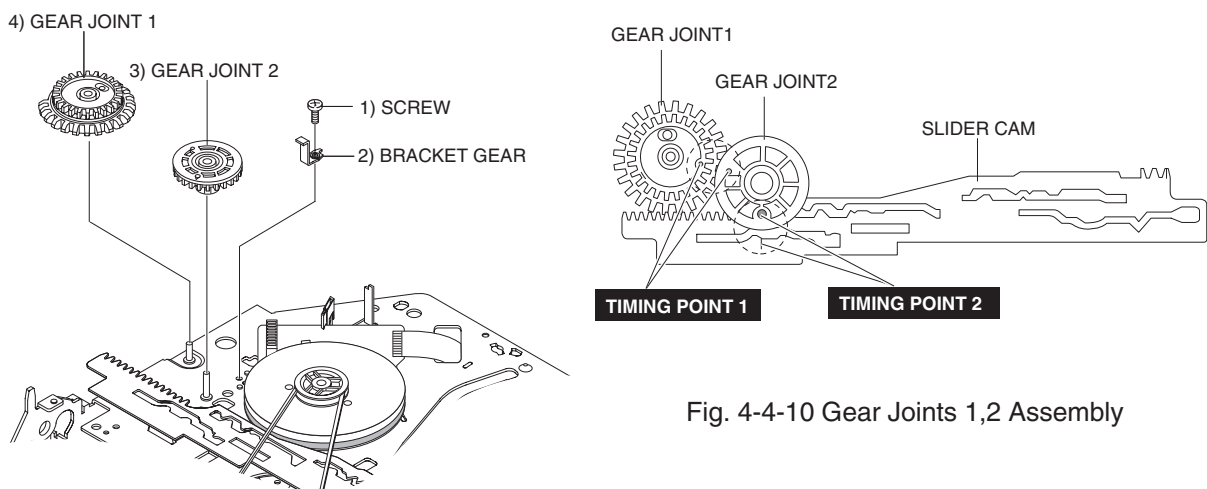

Fig. 4-4-10 Gear Joints 1,2 Assembly

Fig. 4-4-9 Bracket Gear, Gear Joints 1,2 Removal

(9) Gear Loading Drive, Slider Cam, Lever Load S, T Ass'y Removal

- 1) Remove the Belt Pulley.
(Refer to Fig. 4-4-28)
- 2) Remove the Gear Loading Drive after releasing Hook [A] in the direction of arrow as shown in the detailed drawing.
- 3) Remove the Slider Cam.
- 4) Remove the Lever Load S Ass'y & Lever Load T Ass'y.

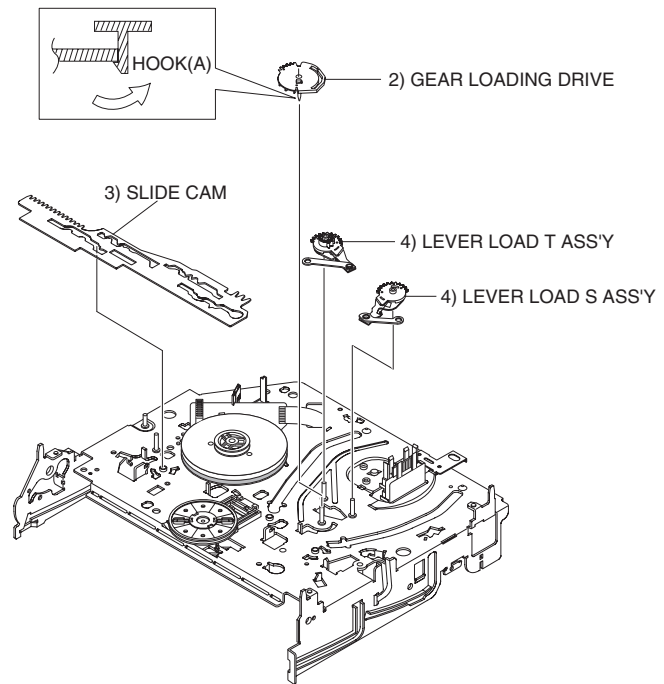

Fig. 4-4-11 Gear Loading Drive, Slider Cam, Lever T, S Load Ass'y Removal

Assembly:

- 1) When reinstalling, be sure to align the dot of Lever Load T Ass'y with the dot of Lever Load S Ass'y as shown in the drawing (Refer to Timing Point 1).
- 2) Insert Pins A,B,C,D into the holes in Slider Cam.
- 3) Be sure to align the dot of Lever Load T and the dot of Gear Loading Drive (Refer to Timing Point 2).
- 4) Align the dot of Gear Loading drive with the mark of Slider Cam as shown in the drawing (Refer to Timing Point 3).

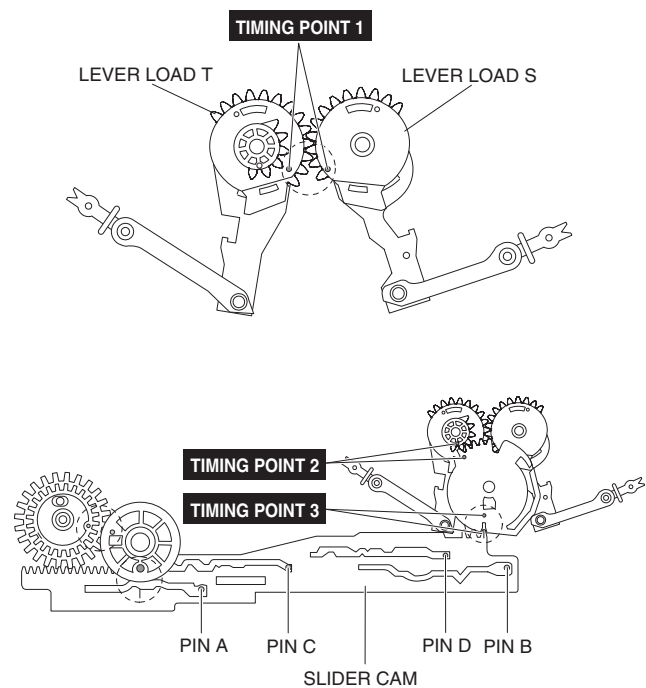

Fig. 4-4-12 Gear Loading Drive, Slider Cam, Lever Load S, T Ass'y Assembly

(10) Lever Pinch Drive, Lever Tension Drive Removal

- 1) Remove the Lever Pinch Drive and Lever Tension Drive.

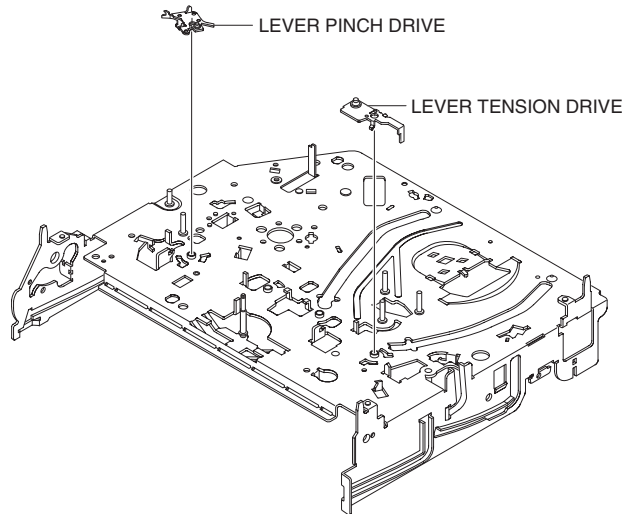

Fig. 4-4-13 Lever Pinch Drive, Lever Tension Drive Removal

(11) Lever Tension Ass'y, Band Brake Ass'y Removal

- 1) Remove the Lever Brake S Ass'y (Refer to Fig 4-4-15).
- 2) Remove the Spring Tension Lever.
- 3) Rotate the stopper of Main Base in the direction of arrow "A".
- 4) Lift the Lever Tension Ass'y and Band Brake Ass'y.

Note :

- 1) When replacing the Lever Tension Ass'y, be sure to apply Grease on the post.
- 2) Take care not to touch stain on the felt side, and not to be folder and broken Band brake Ass'y.
- 3) After Lever Tension Ass'y seated, Rotate stopper of Main Base to the Mark[B].

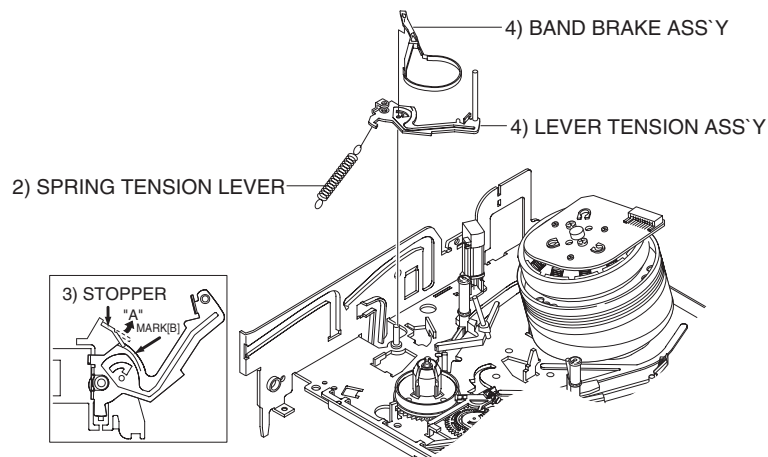

Fig. 4-4-14 Lever Tension Ass'y, Band Brake Ass'y Removal

(12) Lever Brake S, T Ass'y Removal

- 1) Release Hook [A] and Hooks [B], [C] in the directions of arrow.
- 2) Lift the Lever S, T Brake Ass'y with the spring brake.

Note :

Take extreme care not to fold or transform Spring Brake during removing or reinstalling.

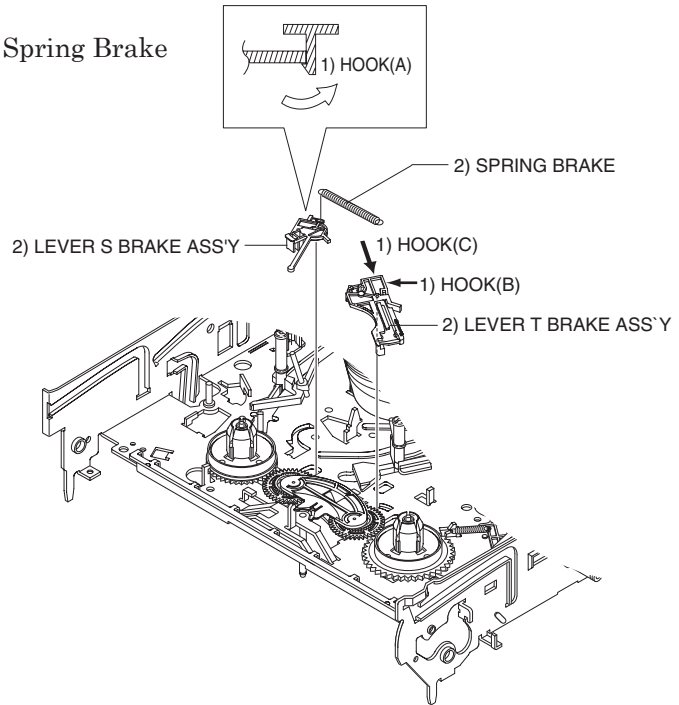

Fig. 4-4-15 Lever Brake S, T Ass'y Removal

(13) Gear Idle Ass'y Removal

- 1) Push the Lever Idle in the direction of arrow "A", "B".
- 2) Lift the Lever Idle.

Assembly :

- 1) Apply oil to the two Bosses of Lever Idle.

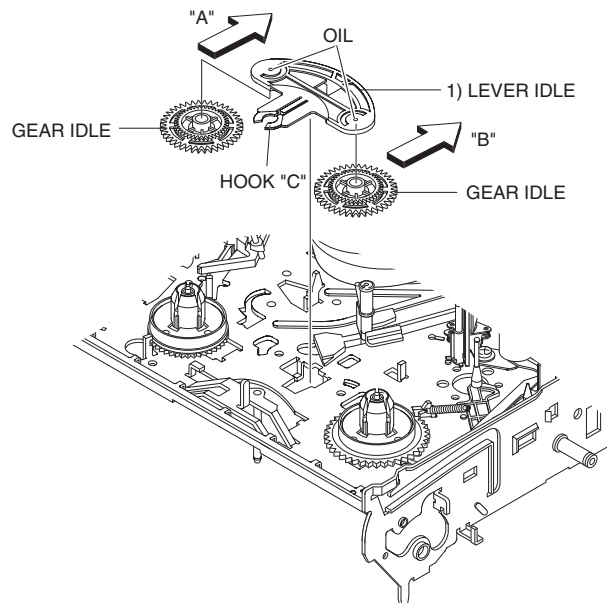

Fig. 4-4-16 Gear Idle Ass'y Removal

(14) Disk S, T Reel Removal

- 1) Lift the Disk S, T Reel.

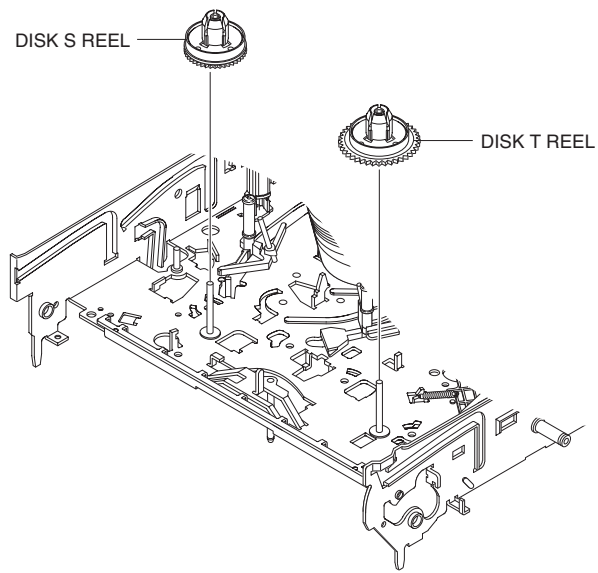

Fig. 4-4-17 Disk S, T Reel Removal

(15) Holder Clutch Ass'y Removal

- 1) Remove the Washer Slit.
- 2) Lift the Holder Clutch Ass'y.

Note :

When you reinstall the Holder Clutch Ass'y:

- 1) Check the condition of spring as shown in detail A.
- 2) Don't push the Holder Clutch Ass'y down with excessive force. Just insert Holder Clutch Ass'y into post center with dead force and Rotate it smoothly.

Be sure to confirm that the spring is in the slit of Gear Center Ass'y as shown in detail B.

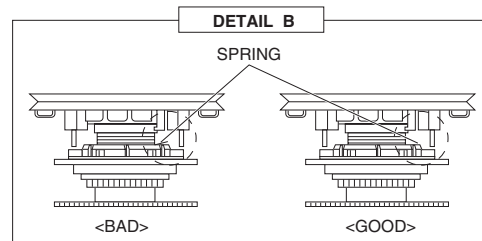
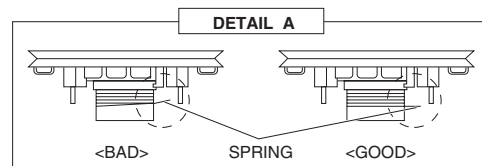
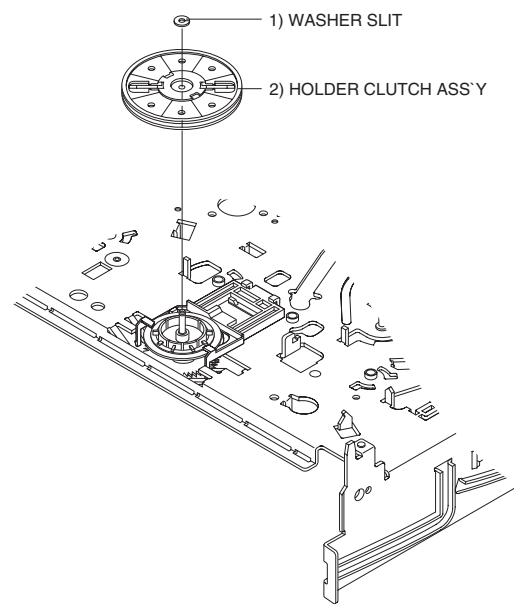

Fig. 4-4-18 Holder Clutch Ass'y Removal

(16) Lever Up/Down Ass'y, Gear Center Ass'y Removal

- 1) Release the 2 hooks in the direction of the arrows as shown Fig. 4-4-19 and lift the Lever Up/Down Ass'y.
- 2) Lift the Gear Center Ass'y.

Assembly :

- 1) Insert the Lever Up/Down Ass'y into the rectangular hole in Main Base as shown in Fig 4-4-20.
- 2) Lift the Lever Up/Down Ass'y approximately 35°. (Refer to Fig 4-4-20)
- 3) Insert the Ring of Gear Center Ass'y into the Guide of Lever Up/Down Ass'y.
- 4) Insert the Gear Center Ass'y into the post on Main Base.
- 5) Push down the Lever Up/Down Ass'y to lock of the Hook.

Note :

Be sure to confirm that Ring of Gear Center Ass'y is between the Guides of Lever Up/Down Ass'y after finishing assembly of Lever Up/Down Ass'y and Gear Center Ass'y.

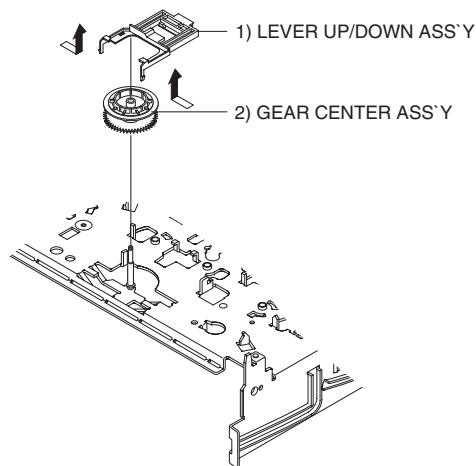

Fig. 4-4-19 Lever Up/Down Ass'y Removal

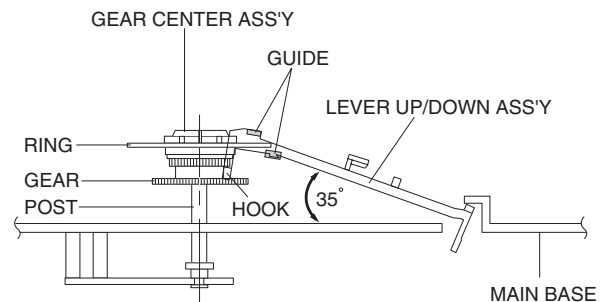

Fig. 4-4-20 Lever Up/Down Ass'y Removal

(17) Guide Cassette Door Removal

- 1) Lift the Guide Cassette Door slightly Hook [A].
- 2) Turn the Guide Cassette Door in the direction of arrow to release Hook [A].

Note:

After reinstalling, turn the Guide Cassette Door, making sure the Hook [A] locks in place.

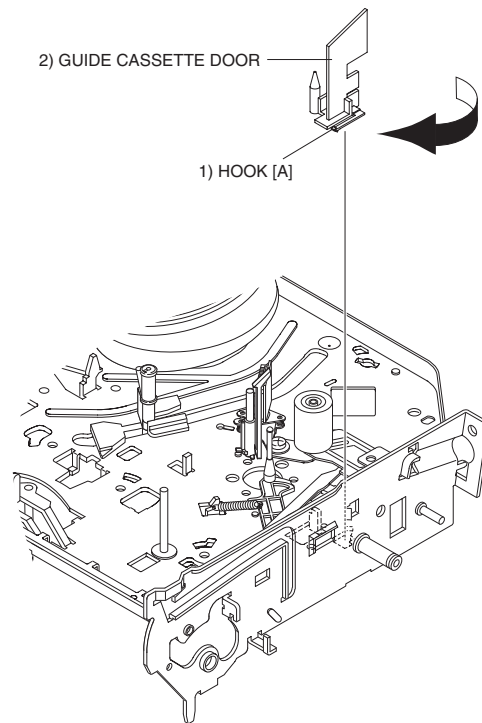

Fig. 4-4-21 Guide Cassette Door Removal

(18) Lever Unit Pinch Ass'y, Plate Joint, Spring Pinch Drive Removal

- 1) Lift the Lever Unit Pinch Ass'y.
- 2) Remove the Plate Joint from Lever Unit Pinch Ass'y.
- 3) Remove the Spring Pinch Drive.

Note :

- 1) Take extreme care so that no grease adheres the Roller Pinch.
- 2) When reinstalling, be sure to apply grease on the post pinch roller.

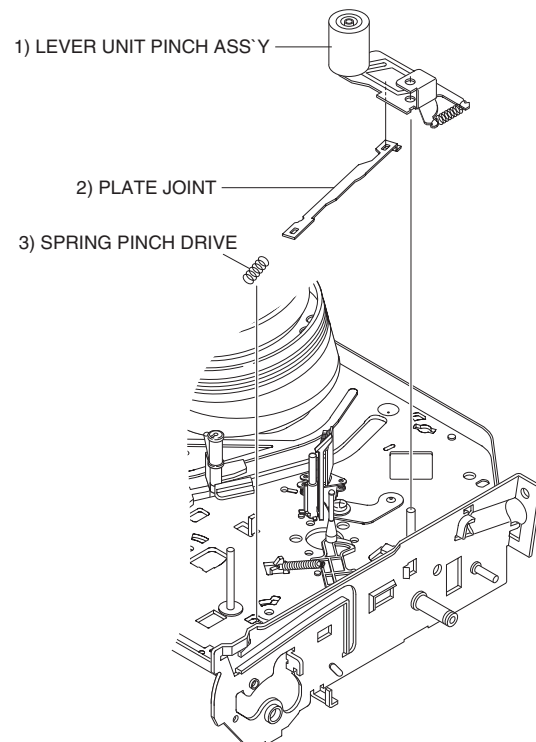

Fig. 4-4-22 Lever Unit Pinch Ass'y, Plate Joint, Spring Pinch Drive Removal

(19) Lever #9 Guide Ass'y Removal

- 1) Remove the Spring #9 Guide.
- 2) Lift the Lever #9 Guide Ass'y in the direction of arrow "A" and "B".

Note :

- 1) Take extreme care so that no grease adheres to the tape Guide Post.
- 2) After reinstalling, make sure the bottom of Post #9 Guide faces the top side of Main Base.

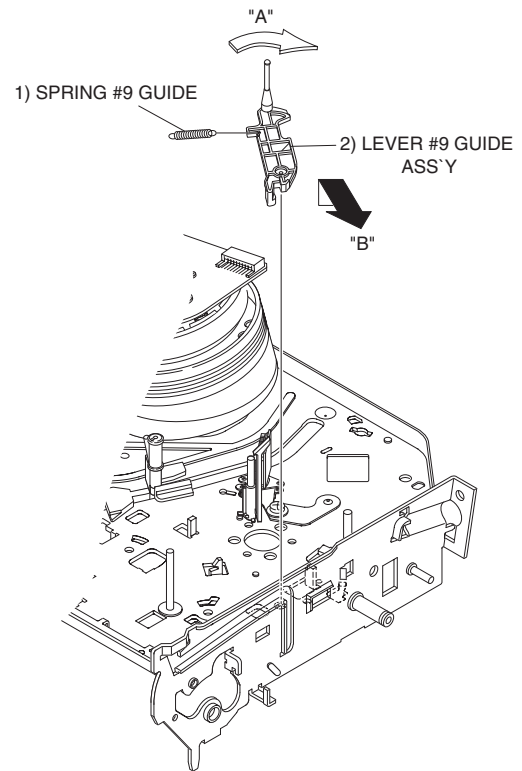

Fig. 4-4-23 Lever #9 Guide Ass'y Removal

(20) FE Head Removal

- 1) Rotate the FE head in the direction of arrow.
- 2) Lift the FE Head.

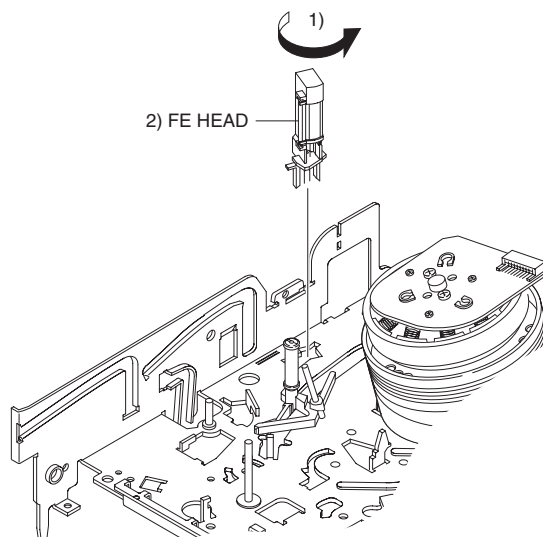

Fig. 4-4-24 FE Head Removal

(21) ACE Head Removal

- 1) Pull out the FPC from the connector of ACE Head Ass'y.
- 2) Remove the screw.
- 3) Lift the ACE Head Ass'y.

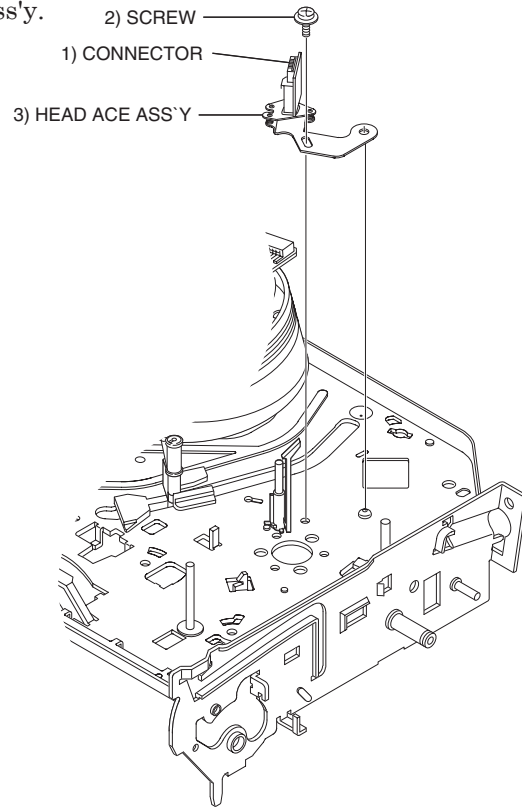

Fig. 4-4-25 ACE Head Removal

(22) Slider S, T Ass'y Removal

- 1) Move the Slider S, T Ass'y in the slots, and then lift them to remove. (Refer to arrow)

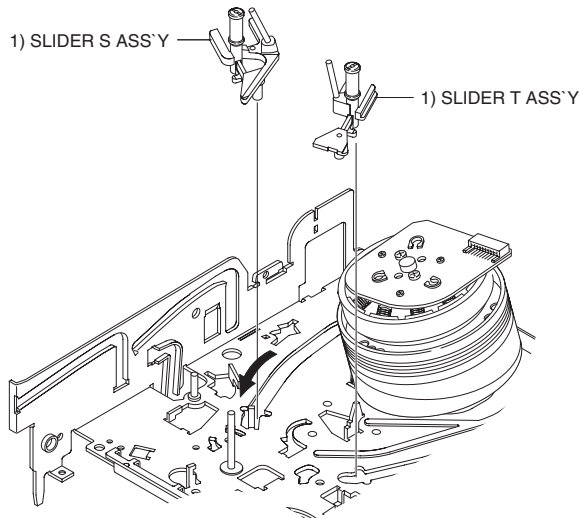

Fig. 4-4-26 Slider S, T Ass'y Removal

(23) Plate Ground Deck, Cylinder Ass'y Removal

- 1) Remove the 3 screws.
- 2) Lift the Plate Ground Deck.
- 3) Lift the Cylinder Ass'y.

Assembly :

- 1) Align the 3 holes in the bottom of Cylinder Ass'y with the 3 holes in Main Base, taking care not to drop or knock the Cylinder Ass'y.
- 2) Tighten the 1 screw.
- 3) Align the Plate Ground Deck with the Hole in Main Base.
- 4) Tighten the other 2 screws.

Note :

- 1) Take care not to touch the Cylinder Ass'y or tape guide post during reassembly.
- 2) When reinstalling, don't push down the Screw Driver with unreasonable force.

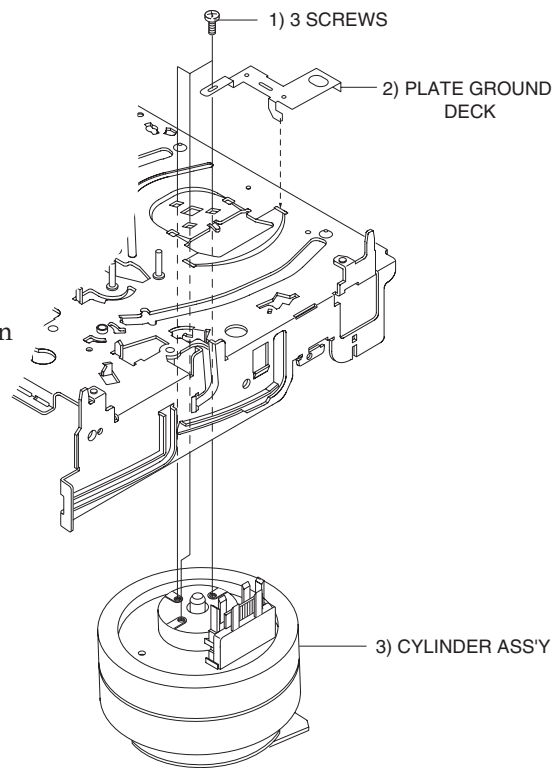

Fig. 4-4-27 Plate Ground Deck, Cylinder Ass'y Removal

(24) Hook Capstan, Belt Pulley Removal

- 1) Remove the Hook Capstan after releasing the Hook in the direction of arrow, as shown in detailed drawing.
- 2) Remove the Belt Pulley.

Note :

Take extreme care so that no grease adheres to the Belt Pulley during disassembly and reassembly.

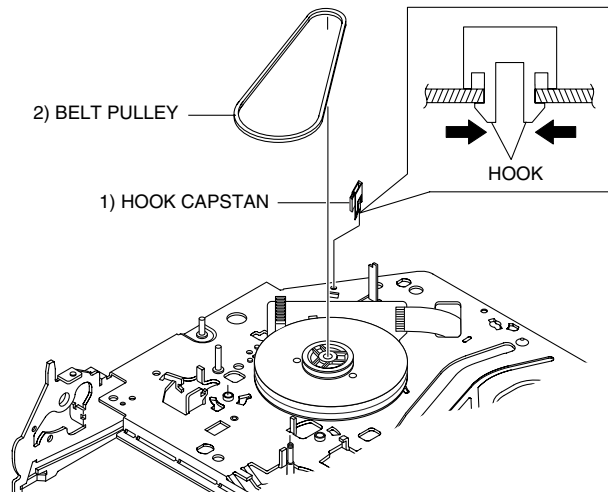

Fig. 4-4-28 Hook Capstan, Belt Pulley Removal

(25) Motor Capstan Ass'y Removal

- 1) Remove the Hook Capstan after releasing the Hook in the direction of arrow, as shown in detailed drawing. (See Fig. 4-4-28)
- 2) Remove the 3 screws.
- 3) Remove the Motor Capstan Ass'y.

Assembly :

- 1) Align the 3 holes in Motor Capstan Ass'y with the 3 holes in Main Base. Be careful not to drop or knock the Motor Capstan Ass'y.
- 2) Tighten the 3 screws in the order shown in detailed drawing.
- 3) Assemble the Hook Capstan.

Note :

After tightening the screws, check if there is a gap between the screw heads and the top side of Main Base. There must be no gap between them. After reinstalling, adjust the tape transport system again.

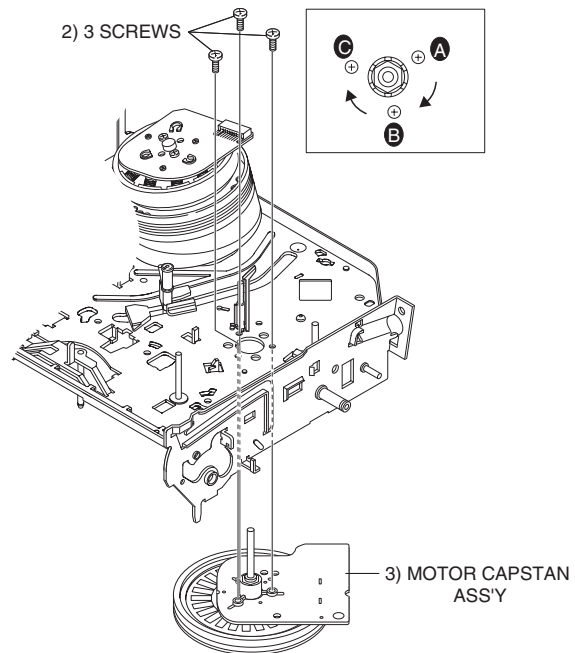

Fig. 4-4-29 Motor Capstan Ass'y Removal

(26) Post #8 Guide Ass'y Removal

- 1) Rotate the Post #8 Guide Ass'y in the direction of arrow to lift it.

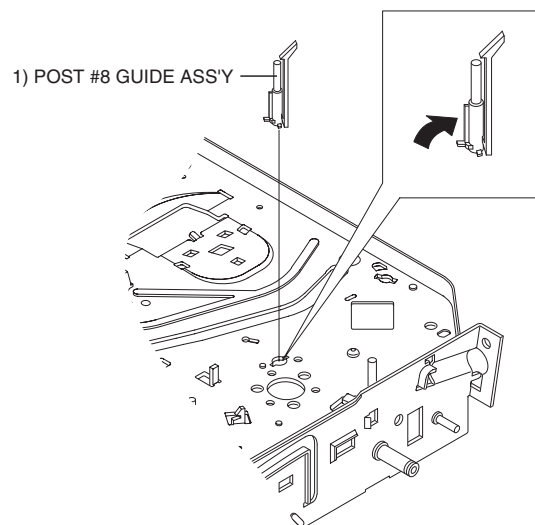

Fig. 4-4-30 Post #8 Guide Ass'y Removal

4-5 The table of cleaning, Lubrication and replacement time about principal parts

- 1) The replacement time of parts is not life of parts.
- 2) The table 4-5-1 is that the VCR Set is in normal condition (normal temperature, normal humidity).

The checking period may be changed owing to the condition of use, runtime and environmental conditions.

- 3) Life of the Cylinder Ass'y is depend on the condition of use.
- 4) See exploded view for location of each parts.

Table 4-5-1

A: Cleaning B : Check and replacement in necessary C : Add Oil

	Parts Name	Checking Period (h)										Remark
		500	1000	1500	2000	2500	3000	3500	4000	4500	5000	
T A P E P A T H S Y S T E M	POST TENSION	A	A	A	A	A	A	A	A	A	A	- To clean the parts, use patch and alcohol (solvent). - After cleaning, use the video tape after alcohol is gone away completely. -We recommend to use oil [EP-56] or solvent. -One or two drops of oil should be applied after cleaning with alcohol. - Periodic time of applying oil (Apply oil after cleaning) - The excessive applying oil may be the cause of malfunction.
	SLANT POST S, T	A	A	A	A	A	A	A	A	A	A	
	#8 GUIDE SHAFT	A	A	A	A	A	A	A	A	A	A	
	CAPSTAN SHAFT	A	A	A	A	A	A	A	A	A	A	
	#9 GUIDE POST	A	A	A	A	A	A	A	A	A	A	
	#3 GUIDE POST	A	A	A	A	A	A	A	A	A	A	
	GUIDE ROLLER S, T	A	A	A	B	B	B	B	B	B	B	
	CYLINDER ASS'Y	A	B	B	B	B	B	B	B	B	B	
	FE HEAD	A	A	A	B	B	B	B	B	B	B	
	ACE HEAD	A	B	B	B	B	B	B	B	B	B	
	PINCH ROLLER	A	B	B	B	B	B	B	B	B	B	
	POST REEL S, T		C		C		C		C		C	
	SLEEVE TENSION		C		C		C		C		C	
	POST CENTER		C		C		C		C		C	
LEVER IDLE BOSS (2Point)		C		C		C		C		C		
A R I V I E M	CAPSTAN MOTOR PULLEY	A	A	A	A	A	B	B	B	B	B	
	BELT PULLEY				B	B	B	B	B	B	B	
	HOLDER CLUTCH ASS'Y	A	B	B	B	B	B	B	B	B	B	
	GEAR CENTER ASS'Y		B	B	B	B	B	B	B	B	B	
	GEAR IDLE (2Point)		B	B	B	B	B	B	B	B	B	
	LOADING MOTOR		B	B	B	B	B	B	B	B	B	
B R A K E	BAND BRAKE ASS'Y		B	B	B	B	B	B	B	B	B	
	BRAKE T ASS'Y		B	B	B	B	B	B	B	B	B	

5-1 Set-up for Adjustment

(1) Test equipment/jigs necessary for adjustment

- 1) Dual-trace oscilloscope
- 2) Color bar generator
- 3) Monitor TV (with A/V jacks)
- 4) Alignment tapes
- 5) Guide roller screwdriver
- 6) Blank tape (VHS)

(2) Connections of test equipment

Connect the equipment as follows when otherwise not specified.

- 1) Connect a color bar generator to the video input 1 jack.
- 2) Connect a monitor TV to the video output 1 jack.
- 3) Connect a monitor TV (able to handle a stereo signal) to the audio output 1 jack.

(3) Cautions on adjustment

- 1) The following conditions apply when otherwise not specified.
probe of oscilloscope: 10:1
Synchronization of oscilloscope: Internal sync
- 2) When performing more than one adjustment, follow the specified order.

(4) List of Adjustment jigs

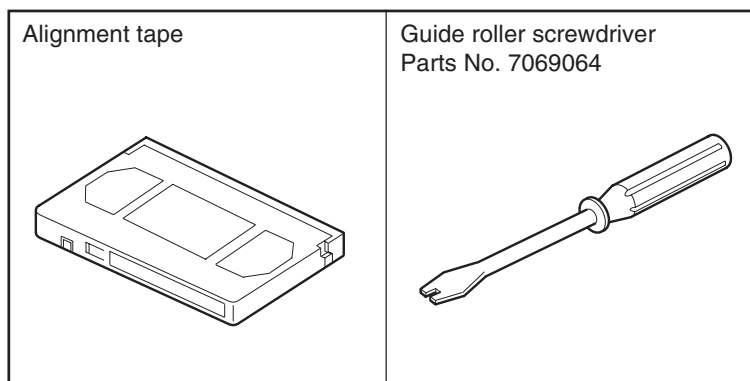

5-2 VCR Electrical Adjustment

5-2-1 Reference

- 1) X-Value (Tracking center) adjustment and “Head switching adjustment” can be performed, using the remote control. (See Fig.5-2-1)
- 2) When replacing the VCR Main PCB Micom (IC601) and NVRAM (IC603 ; EEPROM), be sure to perform the “Head switching adjustment” and “NVRAM option setting”.
- 3) When replacing the cylinder ass’y, be sure to adjust the “X-Value” and perform “Head switching adjustment”.
- 4) How to adjust:
 - Intermittently short-circuit the Test Points on VCR Main PCB with pincers to the adjustment mode. (Make sure that “TEST” appears in the display for approx. 5 seconds.)
 - If the corresponding adjustment button is pressed while “TEST” is being displayed, the adjustment will be performed automatically.
 - When adjustment is finished, turn power off to release the adjustment mode.

(1) Locations of reference buttons on remote control

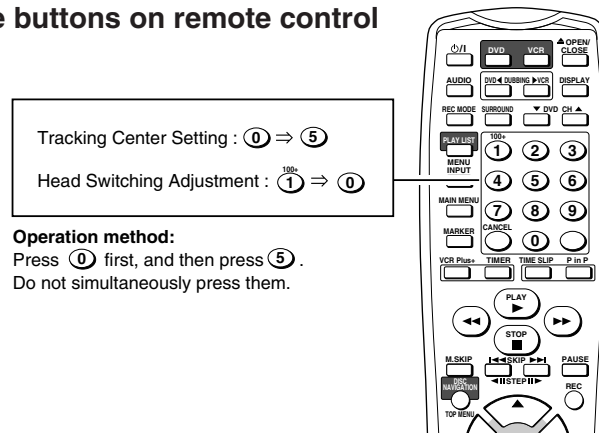

Fig. 5-2-1 Location of reference button of remote control

(2) TEST location for adjustment mode setting

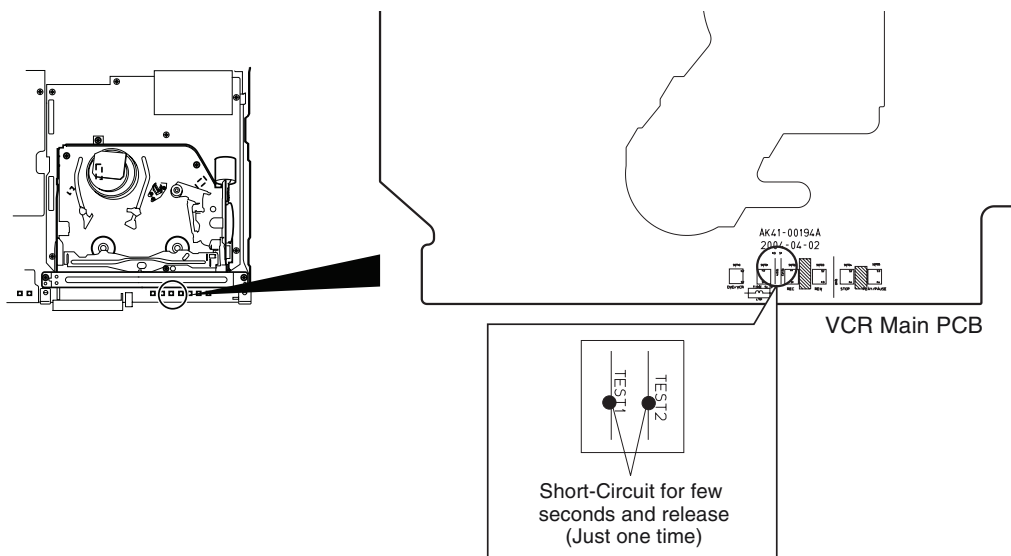

Fig. 5-2-2 Locations of Test points

5-2-2 Head Switching Adjustment

- 1) Play back the alignment tape.
- 2) Intermittently short-circuit the two Test Points on VCR Main P.C.B while in the adjustment mode. Check that “TEST” appears in the display. (See Fig.5-2-2)
- 3) While “TEST” is being displayed, press the [1], [0] buttons: Remote control adjustment will operate automatically. (See Fig.5-2-1)
- 4) Turn power off to release the adjustment mode.

5-2-3 NVRAM Option Setting

- 1) NVRAM Option has been adjusted at the factory.
- 2) If the VCR Main P.C.B Micom (IC601) and NVRAM (IC603 ; EEPROM) are replaced, be sure to set the corresponding option number of the required model. (If the option is not set, the unit will not operate.)

Turn the recorder on with no disc or tape inserted, and then perform the following operations after the loading display disappears:

- 1) Hold down the SKIP/FR and FF/SKIP buttons on recorder simultaneously for approx. 10 seconds.
- 2) The message “Formatting is complete. Turn power off” will appear on the monitor screen.
- 3) Turn the recorder off.

5-3 VCR Mechanism Adjustment

5-3-1 Tape Transport System and Adjustment Locations

The tape transport system has been adjusted precisely at the factory. Alignment is not necessary except for the following :

- 1) Noise observed on the screen.
- 2) Tape damage.
- 3) Parts replacement in the tape transport system.

The lower flange height of #8 guide post is used as a reference for transport adjustment. To maintain the height of the guide post and prevent damage, do not apply excessive force to the main base.

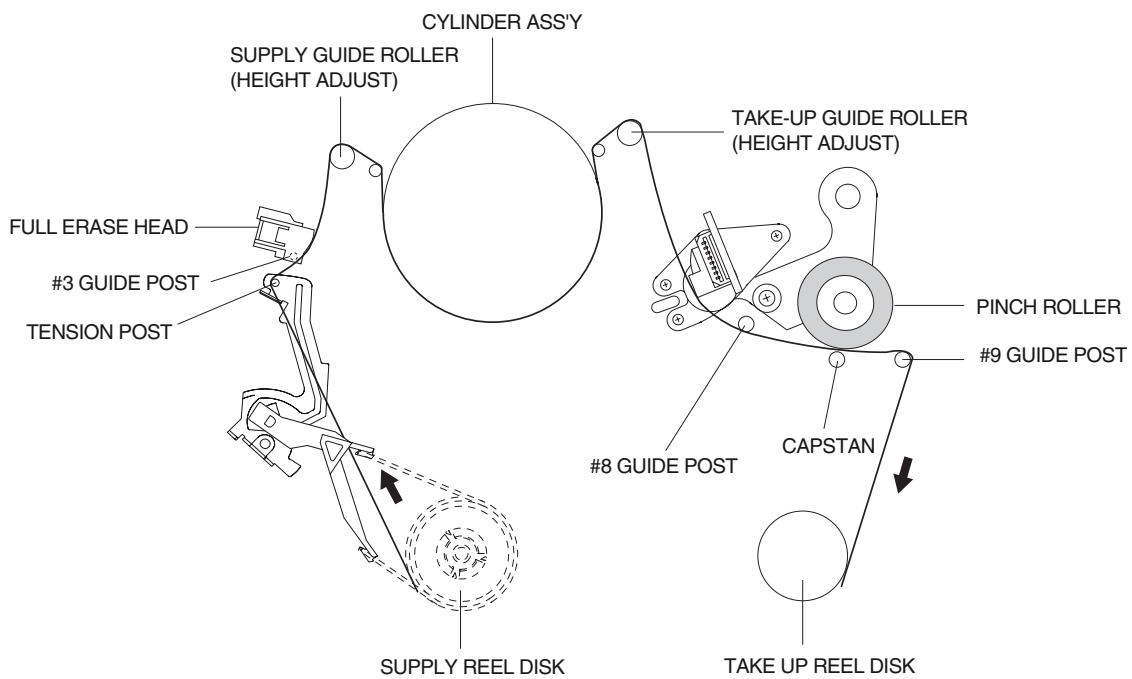

Fig. 5-3-1 Locations of Tape Transport Components

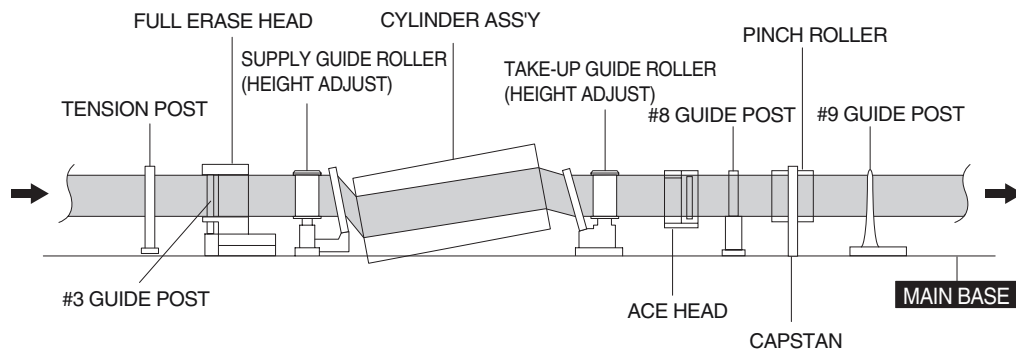

Fig. 5-3-2 Tape Running

5-3-2 Tape Transport System Adjustment

When parts are replaced, perform the required adjustments, referring to the procedures for adjusting the tape transport system. If there are any changes to the tape path, first run a T-120 (E-120) tape and make sure that no excessive tape wrinkle occurs at the guide posts.

- If tape wrinkle is observed at the supply and take-up guide rollers, turn the supply and take-up guide rollers until wrinkle disappears. (See Fig. 5-3-1 and Fig. 5-3-2)
- If the tape wrinkle is still observed at the #8 guide post, perform the ACE head tilt adjustment.

(1) ACE Head Assembly Adjustment

a. ACE Head Height Adjustment

- 1) Play back the alignment tape.
- 2) Observe the surface of audio head using a dental mirror.
- 3) Turn screw (C) clockwise or counterclockwise until the gap between the lower tape edge and the lower edge of control head is approx. 0.25 mm. (See Fig. 5-3-3 and Fig. 5-3-4)

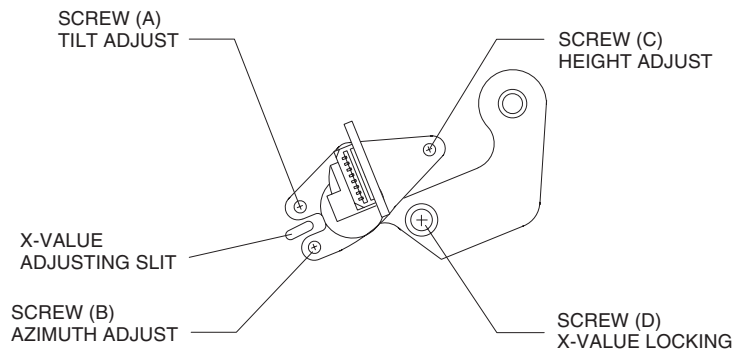

Fig. 5-3-3 Locations of ACE Head Adjustment Screws

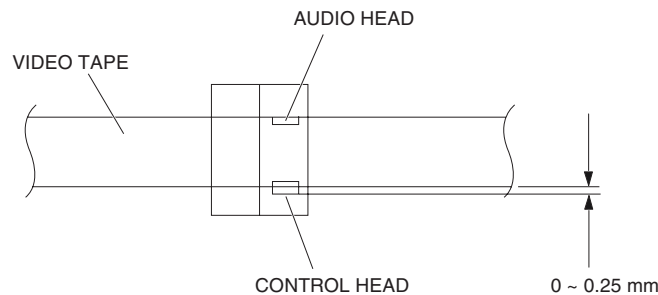

Fig. 5-3-4 ACE Head Height Adjustment

b. ACE Head Tilt Adjustment

- 1) Play back a blank tape and observe the position of the tape at the lower flange of #8 guide post.
- 2) Confirm that there is no curl or wrinkle at the lower flange of #8 guide post as shown in Fig. 5-3-5 (B).
- 3) If a curl or wrinkle of the tape occurs, slightly turn tilt adjustment screw (A) on the ACE head ass'y. (See Fig. 5-3-3)
- 4) Reconfirm the ACE head height. (See section a. ACE Head Height Adjustment)

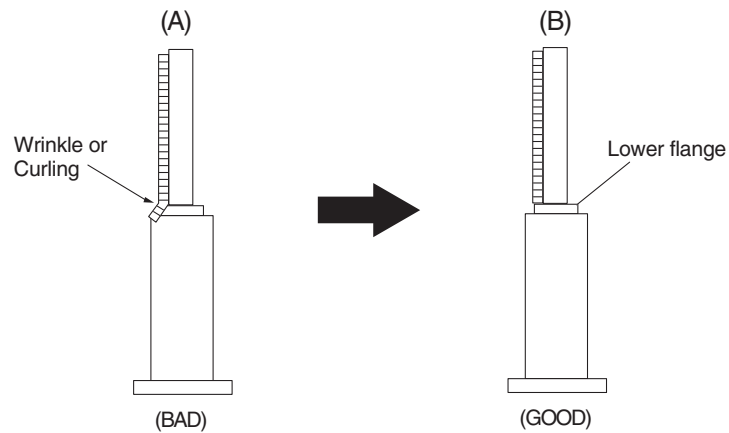

Fig. 5-3-5 #8 Guide Post Check

c. Audio Azimuth Adjustment

- 1) Load alignment tape (Mono scope) and play back the 7 kHz signal.
- 2) Connect channel-1 scope probe to the audio output.
- 3) Adjust screw (B) to maximize the audio level. (See Fig. 5-3-3)

d. ACE Head Position (X-Value) Adjustment

- 1) Play back the alignment tape (Color bar section).
- 2) Intermittently short-circuit the two Test Points on VCR Main P.C.B while in the adjustment mode. Check that "TEST" appears in the display. (See Fig.5-2-2)
- 3) While "TEST" is being displayed, press the [0], [5] buttons on remote control, and the adjustment will operate automatically. (See Fig. 5-2-1)
- 4) Connect the oscilloscope CH-1 probe to TP3 (ENVELOPE) and CH-2 probe to TP4 (Head S/W-Trigger), and then trigger the oscilloscope from CH-2.
- 5) Slightly loosen the X-value securing screw (do not excessively loosen). (See Fig. 5-3-3)
- 6) Insert a flat-bladed screwdriver into the groove for X-value adjustment, and then adjust the X-value to maximize the CH-1 FM output.
- 7) Tighten the X-value securing screw.
- 8) Turn power off to release the adjustment mode.

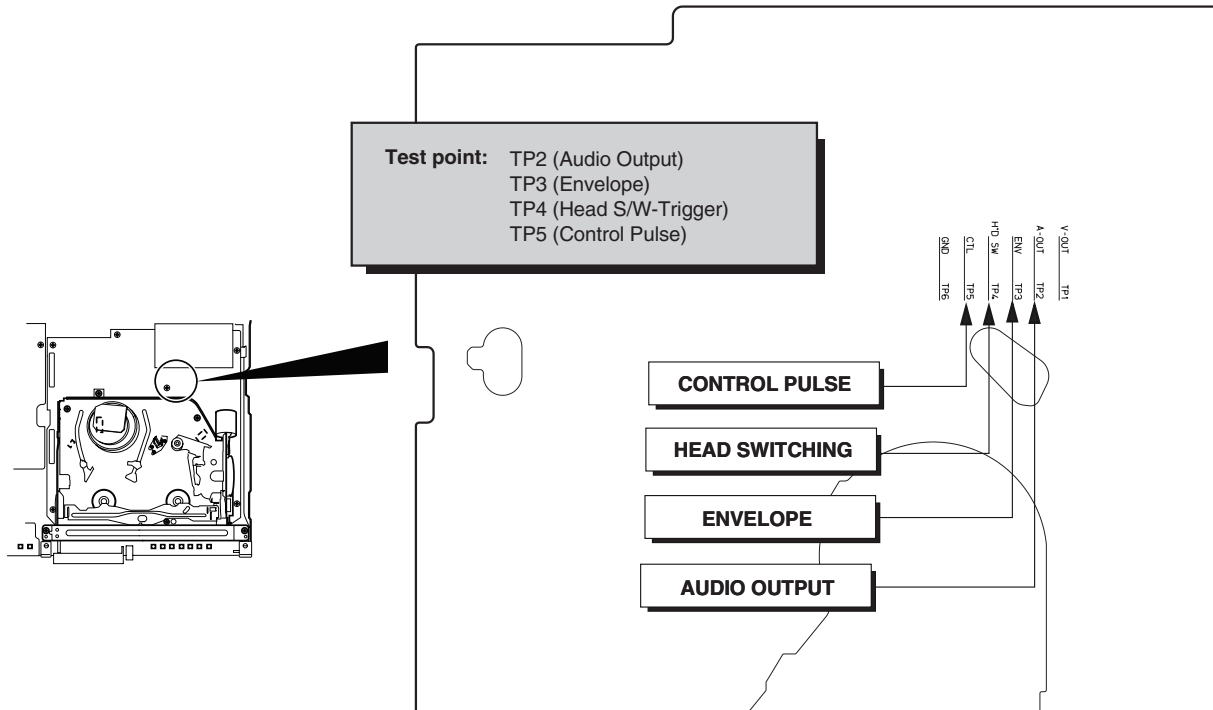

Fig. 5-3-6 Locations of Test points (VCR Main P.C.B-Top View)

(2) FM Output Flatness Adjustment (Supply and Take-up Guide Roller Adjustment)

- 1) Play back the alignment tape.
- 2) Connect the oscilloscope CH-1 probe to TP3 (ENVELOPE) and CH-2 probe to TP4 (Head S/W-Trigger), and then trigger the oscilloscope from CH-2. (See Fig. 5-3-6)
- 3) Observe the FM envelope waveform, and confirm that amplitudes b, c and d are all at least 63% of the FM maximum amplitude (a in the figure).

If these specifications are not satisfied, perform the following adjustments:

a=Maximum output of FM envelope.
 b=Minimum output of FM envelope at the entrance side.
 c= Minimum output of FM envelope at the center point.
 d=Maximum output of FM envelope at the exit side.

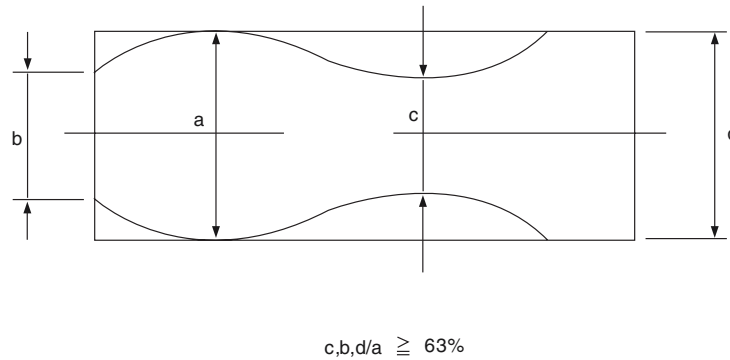

Fig. 5-3-7 FM Envelope Waveform

- 4) If there is a drop in amplitude of FM envelope on the entrance side, adjust the supply guide roller.
- 5) If there is a drop in amplitude of FM envelope on the exit side, adjust the take-up guide roller.

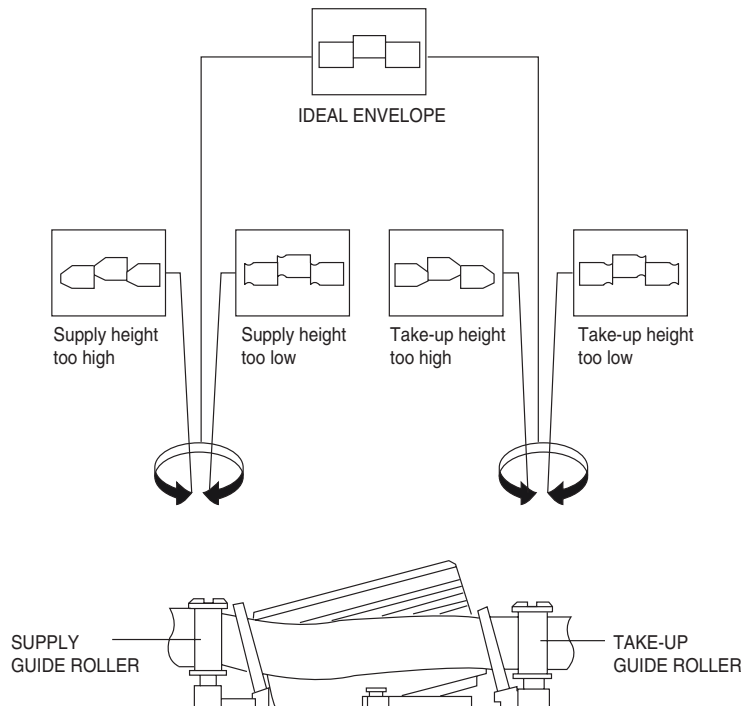

Fig. 5-3-8 Guide Roller Height Adjustment

(3) Check Transitional Operation from RPS to Play

Check transition from RPS mode to play mode: Using a pre-recorded SP tape, make sure the entry side of envelope comes to the appropriate steady state within 3 seconds (as shown in Fig. 5-3-9).

If the envelope waveform does not reach specified peak-to-peak amplitude within 3 seconds, adjust as follows:

- 1) Make sure there is no gap between the roller lower flange of supply guide and the tape.
If there is a gap, turn the supply guide roller height adjustment screw until this gap is eliminated. (See Fig. 5-3-1 and Fig. 5-3-2)
- 2) Change the operation mode from RPS to play (again) and make sure the entrance side of envelope rises within 3 seconds.

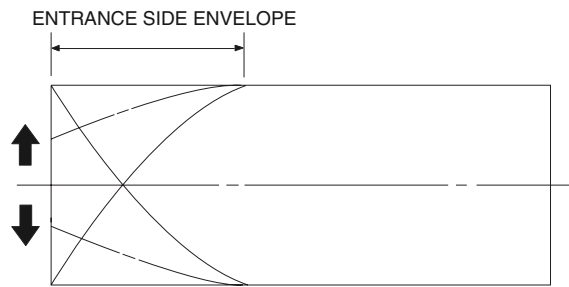

Fig. 5-3-9 Rise of FM Envelope when Operation Mode Changes from RPS to Play

(4) Envelope Check

- 1) Use T-120 (E-120) tape to perform recording and playback on the same machine.
- 2) Check the FM envelope waveform, and make sure that amplitudes A and B are equal. If this cannot be confirmed, check the cylinder, and replace it if necessary.

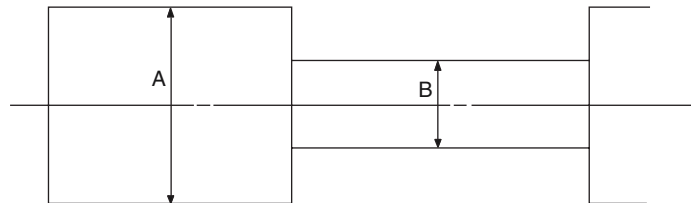

Fig. 5-3-10 FM Envelope Input and Output Levels

(5) Tape Wrinkle Check

- 1) Use T-160 (E-180) tape to perform recording and playback on the same machine.
- 2) Check for wrinkling of tape at each guide post in the playback, FPS, RPS and pause modes.
- 3) If excessive tape wrinkle is observed, perform the following adjustments in playback mode:
 - a) Tape wrinkle at guide rollers: (2) [FM output flatness adjustment \(supply/take-up guide roller adjustments\)](#)
 - b) Tape wrinkle at lower flange of #8 guide post: (1) [ACE head adjustment](#)

5-3-3 Reel Torque

- 1) The rotation of the capstan motor causes the holder clutch ass'y to rotate through the belt pulley.
- 2) The spring wrap PLAY/REV of holder clutch ass'y drives the supply/take-up disk reel through gear idler by rotation of gear center ass'y.
- 3) Brake is operated by slider cam in FF/REW mode.
- 4) The accurate driving force is transmitted by gears (Gear Center Ass'y).

Note : If the following specifications are not satisfied, replace the holder clutch ass'y, and then recheck.

MODE	TORQUE	GAUGE
Play	4.12 ± 1.1 mN·m (42 ± 11 g/cm)	Cassette Torquemeter
RPS (REV Picture Search)	14.22 ± 2.9 mN·m (145 ± 30 g/cm)	Cassette Torquemeter

Torque values in parentheses () are indicated in the conventional unit.

6

Exploded View and Parts List

6-1 Exploded Views

Note: Components without any numbers in exploded views were assigned as service parts as of the date of issue of this manual.

6-1-1 Cabinet Section

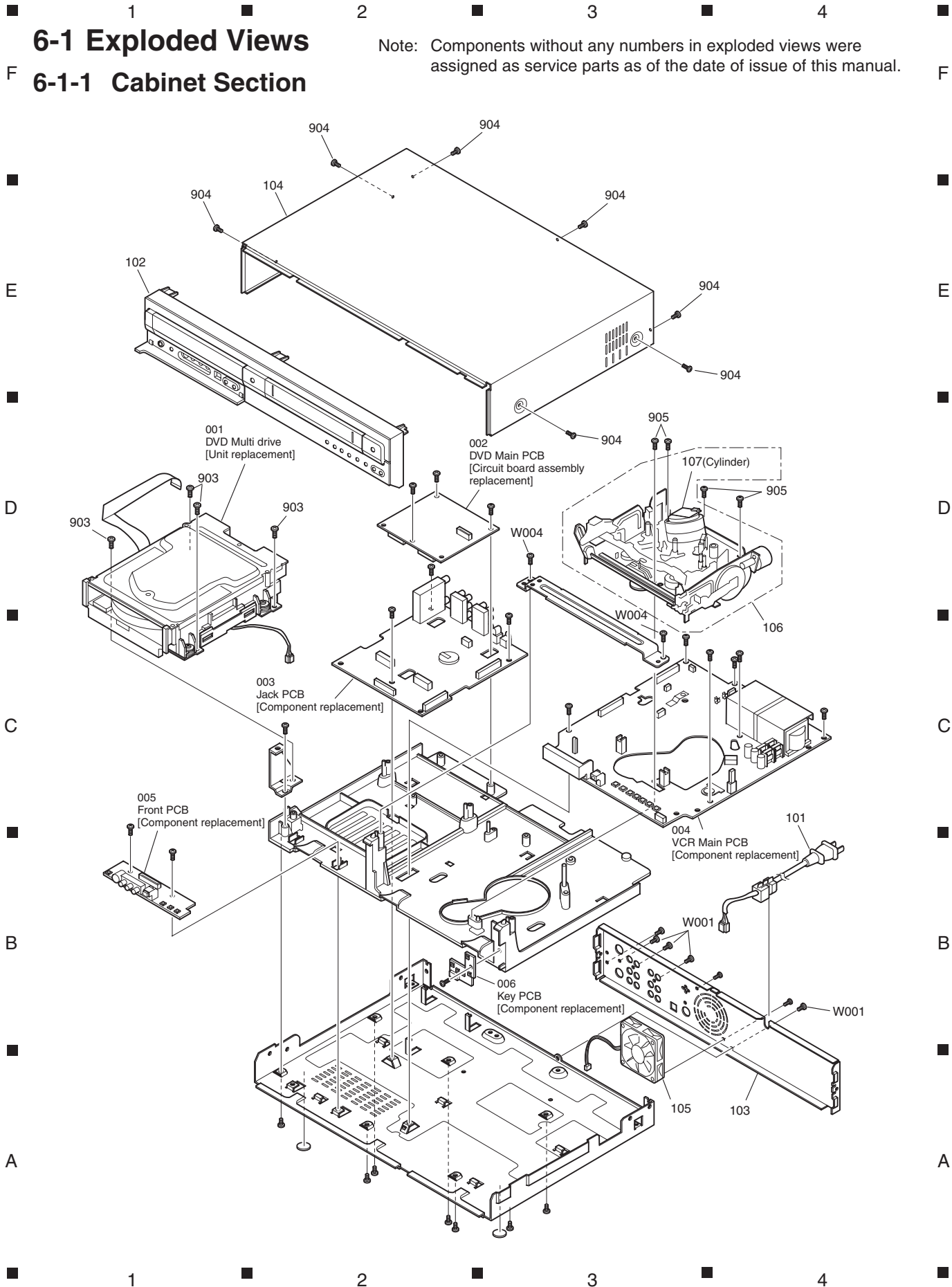

6-1-2 Deck Mechanism Section - Top view

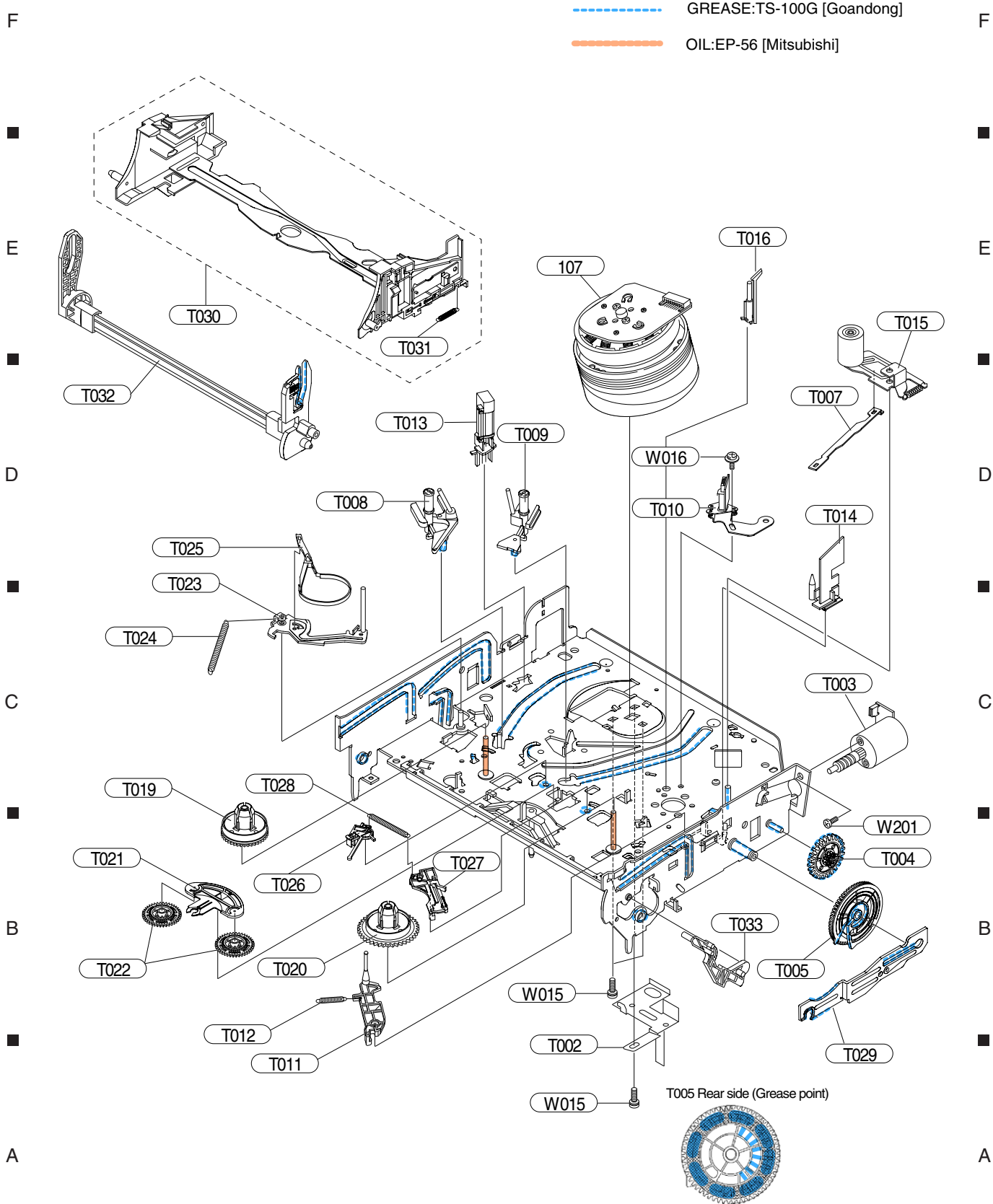

1

2

3

4

6-1-3 Deck Mechanism Section - Bottom view

F

F

----- GREASE:TS-100G [Goandong]

----- OIL:EP-56 [Mitsubishi]

T035 Rear side (Grease point)

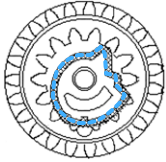

T041 Rear side (Grease point)



T043 Rear side (Grease point)

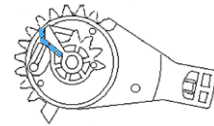

E

E

D

D

C

C

B

B

A

A

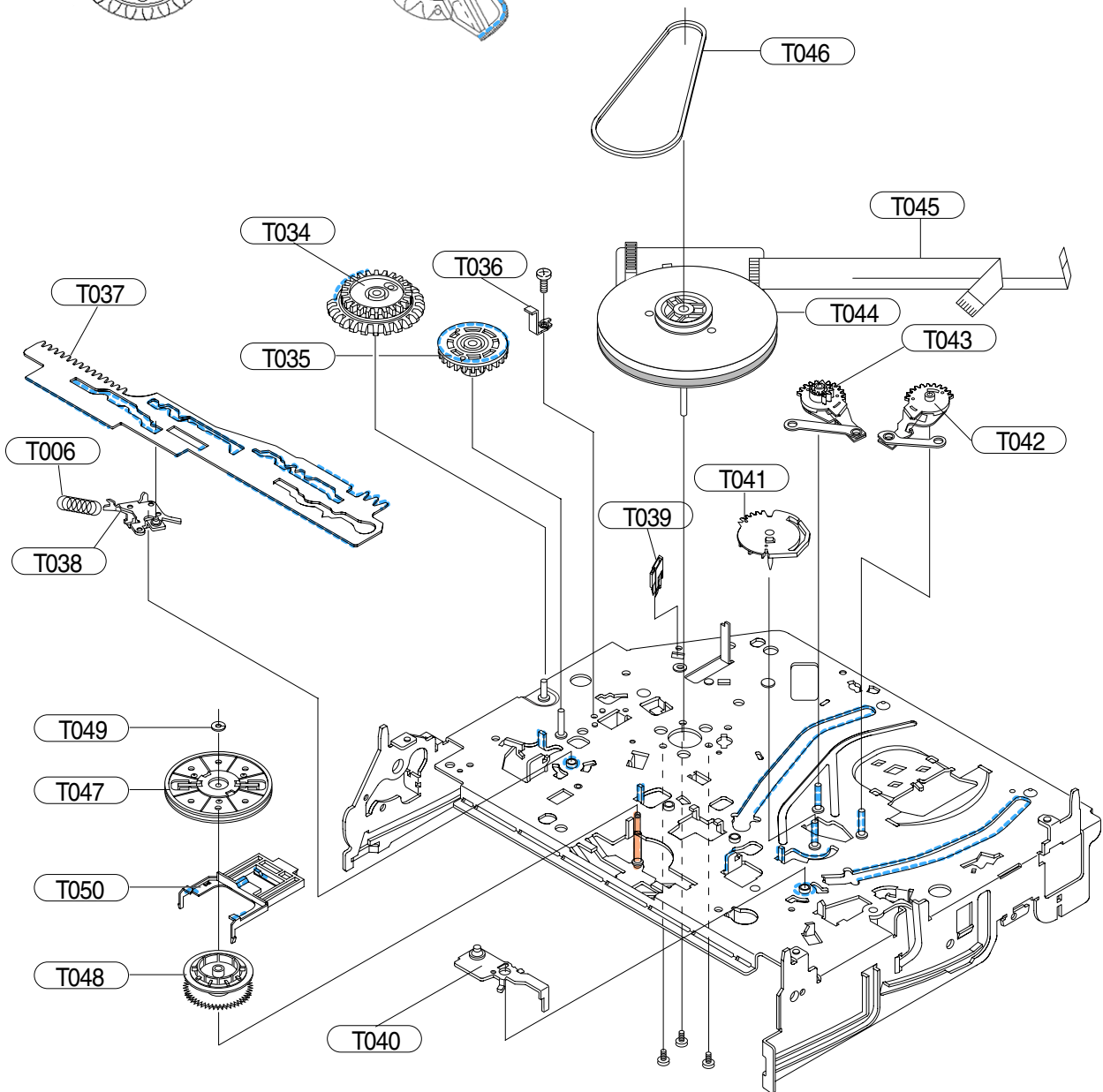

1

2

3

4

6-2 Parts List

6-2-1 Mechanical Parts List

SYMBOL NO	P-NO	DESCRIPTION	SYMBOL NO	P-NO	DESCRIPTION
MECHANISM SECTION					
001	TJ17971	DVD DRIVE ASSY	901	TJ18294	SCREW(M3,L6)
002	TJ17986	PWB ASSY DVD MAIN	903	TJ18293	SCREW(M3,L12)
003	TJ18386	PWB ASSY JACK	904	TJ18292	SCREW(M3,L10)
004	TJ18385	PWB ASSY MAIN	905	TJ18288	SCREW(M5,L14)
005	TJ18061	PWB ASSY FUNCTION	W001	TJ18127	SCREW(M3,L10)
006	TJ18062	PWB ASSY KEY	W004	TJ18128	SCREW(M3,L8)
△ 101	TJ18388	CORD,POWER	W006	TJ18129	SCREW
102	TJ18387	PANEL,FRONT	W015	TJ18131	SCREW(M3.0,L6.0)
103	TJ18384	CHASSIS,REAR	W016	TJ18132	SCREW(M2.6,L5.6)
104	TJ17995	CASE, TOP	W201	TJ18133	SCREW(M3,L3.3)
			ACCESSORIES		
105	TJ17996	FAN	TS18973		REMOTE HAND SET
106	TJ17991	MECHA ASSY	TJ17984		CORD,AV
107	TJ17992	CYLINDER ASSY	TJ17985		CORD,RF
T002	TJ18072	PLATE,DECK			
T003	TJ18073	MOTOR,LOADING			
T004	TJ18074	GEAR,WORM			
T005	TJ18075	GEAR,FL			
T006	TJ18076	SPRING			
T007	TJ18077	PLATE,JOINT			
T008	TJ18078	SLIDER,SUPPLY ASSY			
T009	TJ18079	SLIDE,TAKE UP			
T010	TJ18081	HEAD,AC			
T011	TJ18082	LEVER,GUIDE			
T012	TJ18083	SPRING			
T013	TJ18084	HEAD,FE			
T014	TJ18085	LEVER,FL			
T015	TJ18086	PINCH UNIT			
T016	TJ18087	POST,GUIDE ASSY			
T019	TJ18088	REEL,DISK(S)			
T020	TJ18089	REEL,DISK(T)			
T021	TJ18091	LEVER,IDLER			
T022	TJ18092	GEAR,IDLE			
T023	TJ18093	LEVER,TENSION			
T024	TJ18094	SPRING			
T025	TJ18095	BAND,BRAKE			
T026	TJ18096	LEVER,BRAKE(S)			
T027	TJ18097	LEVER,BRAKE(T)			
T028	TJ18098	SPRING			
T029	TJ18099	SLIDER,FL			
T030	TJ18101	HOLDER,FL			
T031	TJ18102	SPRING			
T032	TJ18103	LEVER,FL ARM			
T033	TJ18104	GUIDE,CASS			
T034	TJ18114	GEAR,JOINT			
T035	TJ18115	GEAR,JOINT			
T036	TJ18107	BRACKET,GEAR			
T037	TJ18113	SLIDER,CAM			
T038	TJ18112	LEVER,PINCH			
T039	TJ18119	HOOK,CAPSTAN			
T040	TJ18111	LEVER,TENSION			
T041	TJ18116	GEAR,LOADING			
T042	TJ18122	LEVER,LOADING(S) ASSY			
T043	TJ18123	LEVER,LOADING(T) ASSY			
T044	TJ18121	MOTOR,CAPSTAN			
T045	TJ18105	CABLE,FLAT			
T046	TJ18118	BELT,PULLEY			
T047	TJ18108	HOLDER,CLUTCH			
T048	TJ18117	GEAR,CENTER			
T049	TJ18106	WASHER			
T050	TJ18109	LEVER,UP DOWN			

6-2-2 Electrical Parts List

Note: Although some parts in the schematic diagrams have different names from those in the parts list, there is no problem in replacing parts.

SYMBOL NO	P-NO	DESCRIPTION	SYMBOL NO	P-NO	DESCRIPTION
AD1	TJ18141	DIODE DAN202K	D704	TJ18344	DIODE 1N4148
AD2	TJ18141	DIODE DAN202K	DOIC1	TJ18143	IC M74HCU04
AD5	TJ18141	DIODE DAN202K	DOL1	TJ18358	FILTER
AIC4	TJ18144	IC AMP4560	DOL3	TJ18256	INDUCTOR 10UH
AIC5	TJ18144	IC AMP4560	DOZ1	TJ18357	ZENER DIODE UDZ9.1B
AQ1	TJ18146	TRANSISTOR NPN,200MW	DOZ2	TJ18357	ZENER DIODE UDZ9.1B
AQ2	TJ18147	TRANSISTOR KSR2103	DT701	TJ18323	LED,DISPLAY
AQ3	TJ18181	TRANSISTOR KSC1623	△ F1S01	TJ18189	FUSE 250V 1.6A
AQ4	TJ18146	TRANSISTOR NPN,200MW	FC1S01	TJ18221	FUSE
AQ5	TJ18147	TRANSISTOR KSR2103	FC1S02	TJ18221	FUSE
AQ6	TJ18181	TRANSISTOR KSC1623	FJACK1	TJ18337	CONNECTOR 27P
AQ7	TJ18146	TRANSISTOR NPN,200MW	FJACK2	TJ18337	CONNECTOR 27P
AQ8	TJ18147	TRANSISTOR KSR2103	FJACKB	TJ18336	CABLE 27P
ATCN1B	TJ18291	CABLE 40P	GP601	TJ18329	SHIELD CASE
AVIO	TJ18224	JACK 1P	IC1P01	TJ18318	IC REG 7812
AZ1	TJ18357	ZENER DIODE UDZ9.1B	IC1P02	TJ18208	IC KA78R12
AZ2	TJ18357	ZENER DIODE UDZ9.1B	IC1P03	TJ18319	IC REG G9105
AZ3	TJ18357	ZENER DIODE UDZ9.1B	IC1P05	TJ18321	IC REG G9205
AZ4	TJ18357	ZENER DIODE UDZ9.1B	IC1P06	TJ18319	IC REG G9105
BD01	TJ18309	DIODE GBJ2J	IC1P07	TJ18208	IC KA78R12
BD1S01	TJ18341	COIL	IC1S01	TJ18215	IC ICE2BS01
CN01	TJ18303	CONNECTOR 33P	△ IC1S02	TJ18195	PHOTO COUPLER
CN01B	TJ18311	CABLE 33P	IC1S03	TJ18201	IC KA431Z
CN02	TJ18303	CONNECTOR 33P	IC301	TJ18371	IC LA71207
CN02B	TJ18311	CABLE 33P	IC4M01	TJ18369	IC LA72670M-MPB
CN03	TJ18199	CONNECTOR 4P	IC501	TJ18369	IC LA72670M-MPB
CN03B	TJ18322	CONNECTOR,LEAD	IC601	TJ18367	IC MM101DF10G
CN04	TJ18307	CONNECTOR 2P	IC603	TJ18317	IC S524A40X
CN1S01	TJ18194	CONNECTOR 2P	IC6B1	TJ18348	IC PST572K
CN3	TJ18295	CONNECTOR 30P	IC701	TJ18368	IC PT6959
CN301	TJ18302	CONNECTOR 10P	IC801	TJ18359	IC LA7274M
CN302	TJ18308	CONNECTOR,SOCKET	JACK1	TJ18297	JACK 6P
CN303	TJ18304	CONNECTOR 6P	JK801	TJ18298	JACK 6P
CN303B	TJ18301	CABLE 6P	L1P02	TJ18349	INDUCTOR 100UH
CN4	TJ18295	CONNECTOR 30P	L1P101	TJ18349	INDUCTOR 100UH
CN5	TJ18305	CONNECTOR	△ L1S02	TJ18312	FILTER
CN604	TJ18305	CONNECTOR	L1S30	TJ18212	COIL
CN7	TJ18154	JACK 4P	L1S31	TJ18212	COIL
CN701	TJ18306	CONNECTOR 8P	L1S32	TJ18339	COIL
CN702	TJ18335	CONNECTOR 8P	L301	TJ18341	COIL
CORD	TJ18382	CORD,POWER(HOUSING)	L305	TJ18341	COIL
D1P101	TJ18344	DIODE 1N4148	L306	TJ18227	INDUCTOR 15000UH
D1P102	TJ18344	DIODE 1N4148	L307	TJ18349	INDUCTOR 100UH
D1P103	TJ18344	DIODE 1N4148	L308	TJ18352	INDUCTOR 47UH
D1P104	TJ18381	DIODE 1N5408	L4M01	TJ18338	INDUCTOR 100UH
D1P105	TJ18156	DIODE 1N4002	L4M02	TJ18341	COIL
D1P106	TJ18156	DIODE 1N4002	L601	TJ18351	INDUCTOR 100UH
D1P107	TJ18156	DIODE 1N4002	L602	TJ18349	INDUCTOR 100UH
D1P108	TJ18156	DIODE 1N4002	L603	TJ18349	INDUCTOR 100UH
D1S05	TJ18218	DIODE UF4007	L604	TJ18349	INDUCTOR 100UH
D1S06	TJ18344	DIODE 1N4148	L701	TJ18349	INDUCTOR 100UH
D1S07	TJ18203	DIODE F1T4	L801	TJ18363	INDUCTOR 100UH
D1S30	TJ18204	DIODE SRAF560	L802	TJ18363	INDUCTOR 100UH
D1S31	TJ18204	DIODE SRAF560	LD601	TJ18324	LED,IR
D1S32	TJ18204	DIODE SRAF560	LD601A	TJ18315	HOLDER,LED
D1S33	TJ18204	DIODE SRAF560	LS01	TJ18363	INDUCTOR 100UH
D1S34	TJ18203	DIODE F1T4	MCON1	TJ18303	CONNECTOR 33P
D1S35	TJ18205	DIODE SHG2D	MCON2	TJ18303	CONNECTOR 33P
D1S37	TJ18203	DIODE F1T4	PL3	TJ18256	INDUCTOR 10UH
D501	TJ18141	DIODE DAN202K	PT1SD1	TJ18334	TRANS,SWITCHING
D601	TJ18344	DIODE 1N4148	PT601	TJ18327	PHOTO INTERRUPTER
D605	TJ18344	DIODE 1N4148	PT602	TJ18327	PHOTO INTERRUPTER
D701	TJ18344	DIODE 1N4148	Q1P103	TJ18213	TRANSISTOR GFP50N03
D702	TJ18344	DIODE 1N4148	Q1P105	TJ18355	TRANSISTOR KSC2328A
D703	TJ18344	DIODE 1N4148	Q1P106	TJ18354	TRANSISTOR KSR2001

SYMBOL NO	P-NO	DESCRIPTION	SYMBOL NO	P-NO	DESCRIPTION
Q1P107	TJ18145	TRANSISTOR KSC945			
Q1P108	TJ18355	TRANSISTOR KSC2328A			
Q1P109	TJ18355	TRANSISTOR KSC2328A			
Q1P110	TJ18355	TRANSISTOR KSC2328A			
Q1S01	TJ18216	TRANSISTOR SPA04N60C3			
Q302	TJ18148	TRANSISTOR KSA812			
Q303	TJ18181	TRANSISTOR KSC1623			
Q304	TJ18148	TRANSISTOR KSA812			
Q305	TJ18356	TRANSISTOR KTC3203			
Q306	TJ18148	TRANSISTOR KSA812			
Q307	TJ18356	TRANSISTOR KTC3203			
Q308	TJ18356	TRANSISTOR KTC3203			
Q601	TJ18372	TRANSISTOR KSR1104			
Q701	TJ18181	TRANSISTOR KSC1623			
Q702	TJ18181	TRANSISTOR KSC1623			
Q801	TJ18148	TRANSISTOR KSA812			
QS01	TJ18148	TRANSISTOR KSA812			
QS02	TJ18181	TRANSISTOR KSC1623			
QS03	TJ18181	TRANSISTOR KSC1623			
RM701	TJ18325	MODULE,REMOCON			
S602	TJ18326	PHOTO TRANSISTOR			
SJACK	TJ18296	JACK 4P			
SW602	TJ18333	SWITCH,REC			
SW603	TJ18332	SWITCH,MODE			
SW701	TJ18353	SWITCH,TACT			
SW702	TJ18353	SWITCH,TACT			
SW703	TJ18353	SWITCH,TACT			
SW704	TJ18353	SWITCH,TACT			
SW705	TJ18353	SWITCH,TACT			
SW706	TJ18353	SWITCH,TACT			
SW709	TJ18353	SWITCH,TACT			
SW710	TJ18353	SWITCH,TACT			
SW712	TJ18353	SWITCH,TACT			
SW713	TJ18353	SWITCH,TACT			
SW714	TJ18353	SWITCH,TACT			
SW715	TJ18353	SWITCH,TACT			
SW721	TJ18353	SWITCH,TACT			
SW722	TJ18353	SWITCH,TACT			
TM401	TJ18299	TUNER BLOCK			
VIC1	TJ18362	IC LA73054			
VL6	TJ18256	INDUCTOR 10UH			
VZ1	TJ18357	ZENER DIODE UDZ9.1B			
VZ10	TJ18357	ZENER DIODE UDZ9.1B			
VZ2	TJ18357	ZENER DIODE UDZ9.1B			
VZ3	TJ18357	ZENER DIODE UDZ9.1B			
VZ4	TJ18357	ZENER DIODE UDZ9.1B			
VZ5	TJ18357	ZENER DIODE UDZ9.1B			
VZ6	TJ18357	ZENER DIODE UDZ9.1B			
VZ7	TJ18357	ZENER DIODE UDZ9.1B			
VZ8	TJ18357	ZENER DIODE UDZ9.1B			
VZ9	TJ18357	ZENER DIODE UDZ9.1B			
XT301	TJ18343	CRYSTAL			
XT601	TJ18342	CRYSTAL			
ZD1P02	TJ18345	ZENER DIODE MTZJ12B			
ZD1P03	TJ18347	ZENER DIODE MTZJ9.1B			
ZD1P04	TJ18346	ZENER DIODE MTZJ5.1B			
ZD1S01	TJ18202	ZENER DIODE MTZJ4.3B			
ZD1S02	TJ18219	ZENER DIODE MTZJ20B			
ZD401	TJ18187	ZENER DIODE UZP33B			

S SCHEMATIC, WIRING DIAGRAMS

S-1 Wiring Diagram

For schematic Diagram
- Resistors are in ohms, 1/8W unless otherwise noted.

Special note :
Most semiconductor devices are electrostatically sensitive and therefore require the special handling techniques described under the "Electrostatic Protection Measures" section of this service manual.

Note :
Do not use the part number shown on this drawing for ordering. The correct part number is shown in the parts list (may be slightly different or amended since this drawing was prepared).

Important safety notices :
Components identified with the mark Δ have the special characteristics for safety. When replacing any of these components. Use only the same type.

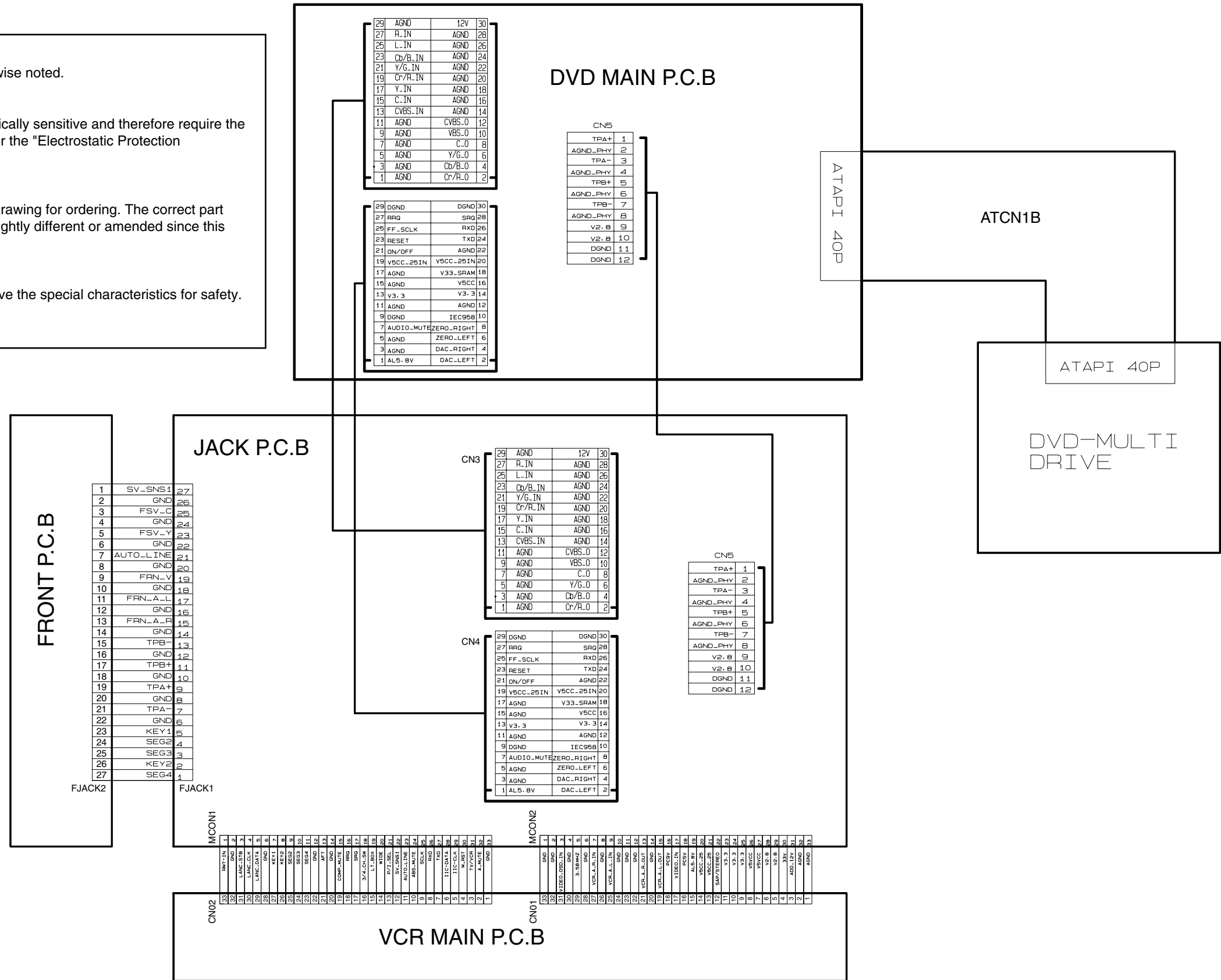

S-2 S.M.P.S Schematic Diagram (VCR Main P.C.B)

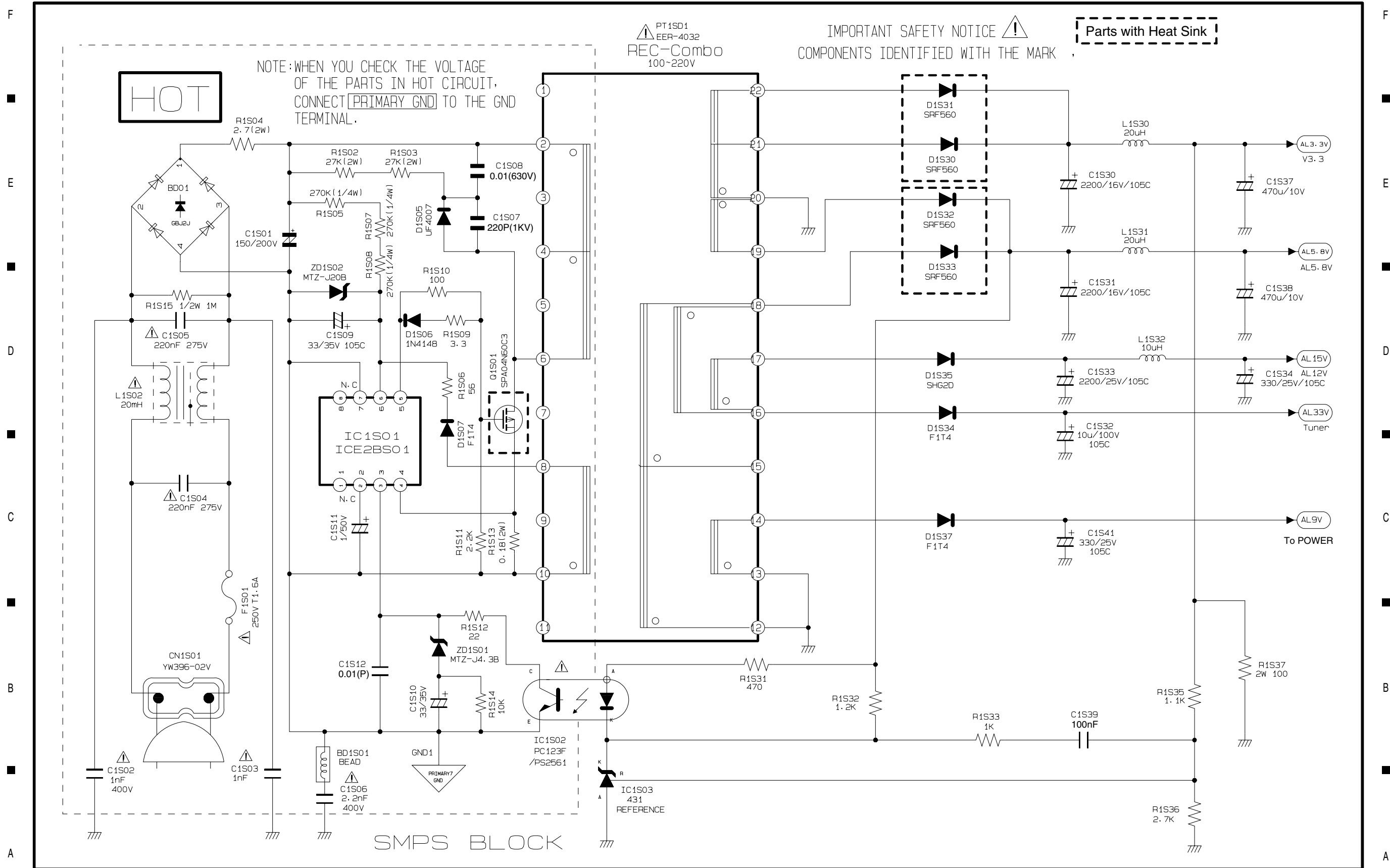

S-3 Power Schematic Diagram (VCR Main P.C.B)

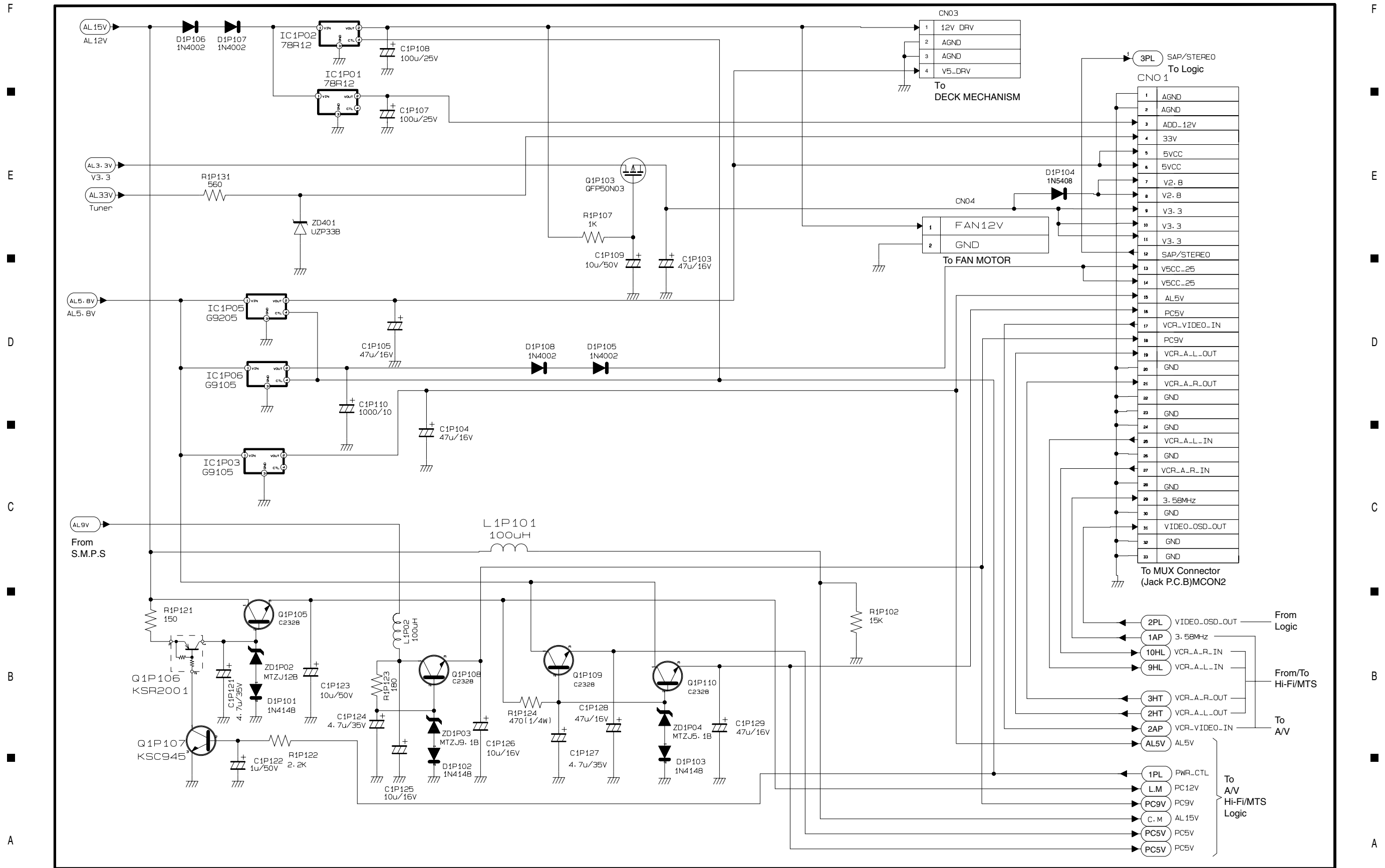

S-4 Logic Schematic Diagram (VCR Main P.C.B)

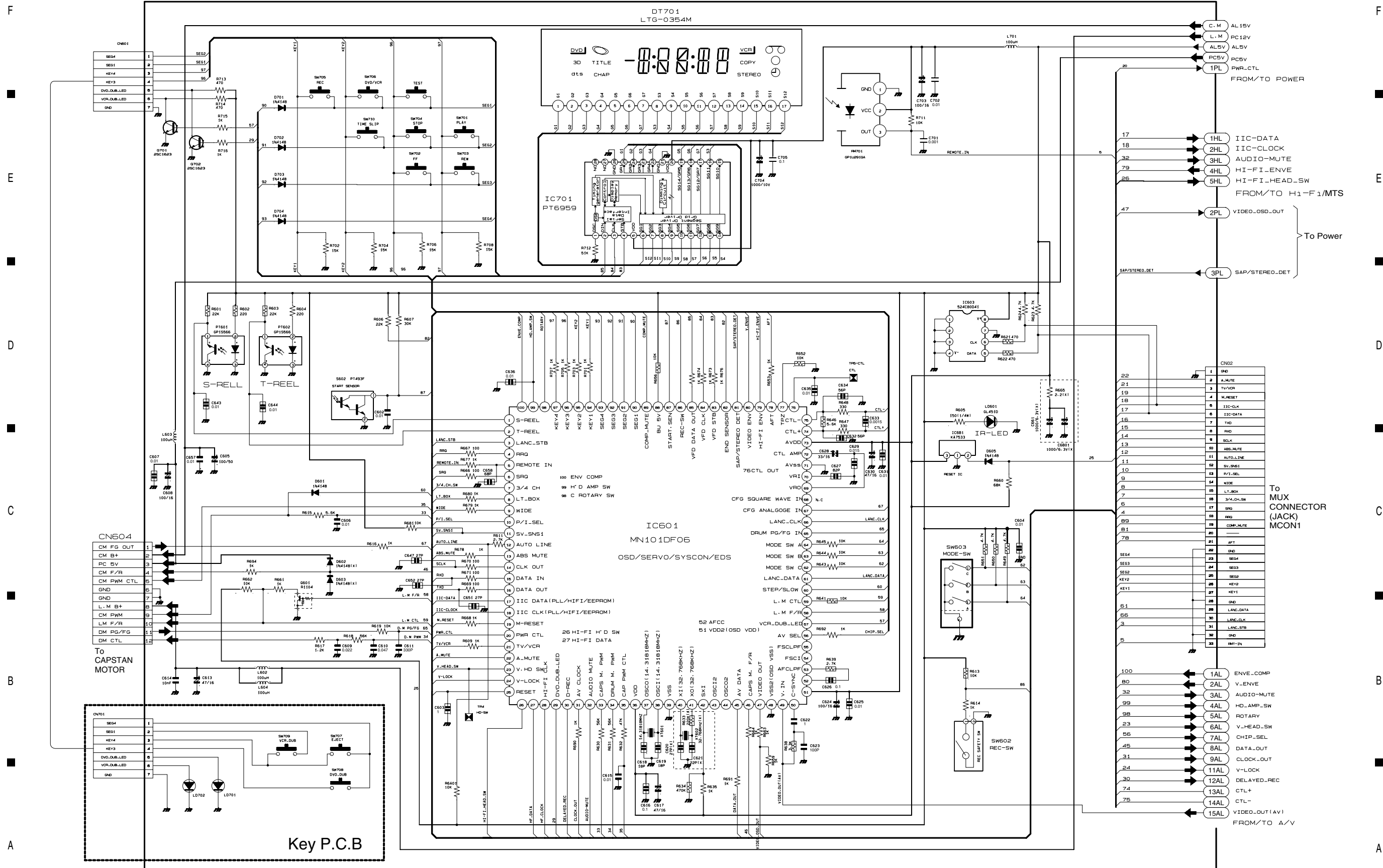

S-5 A/V Schematic Diagram (VCR Main P.C.B)

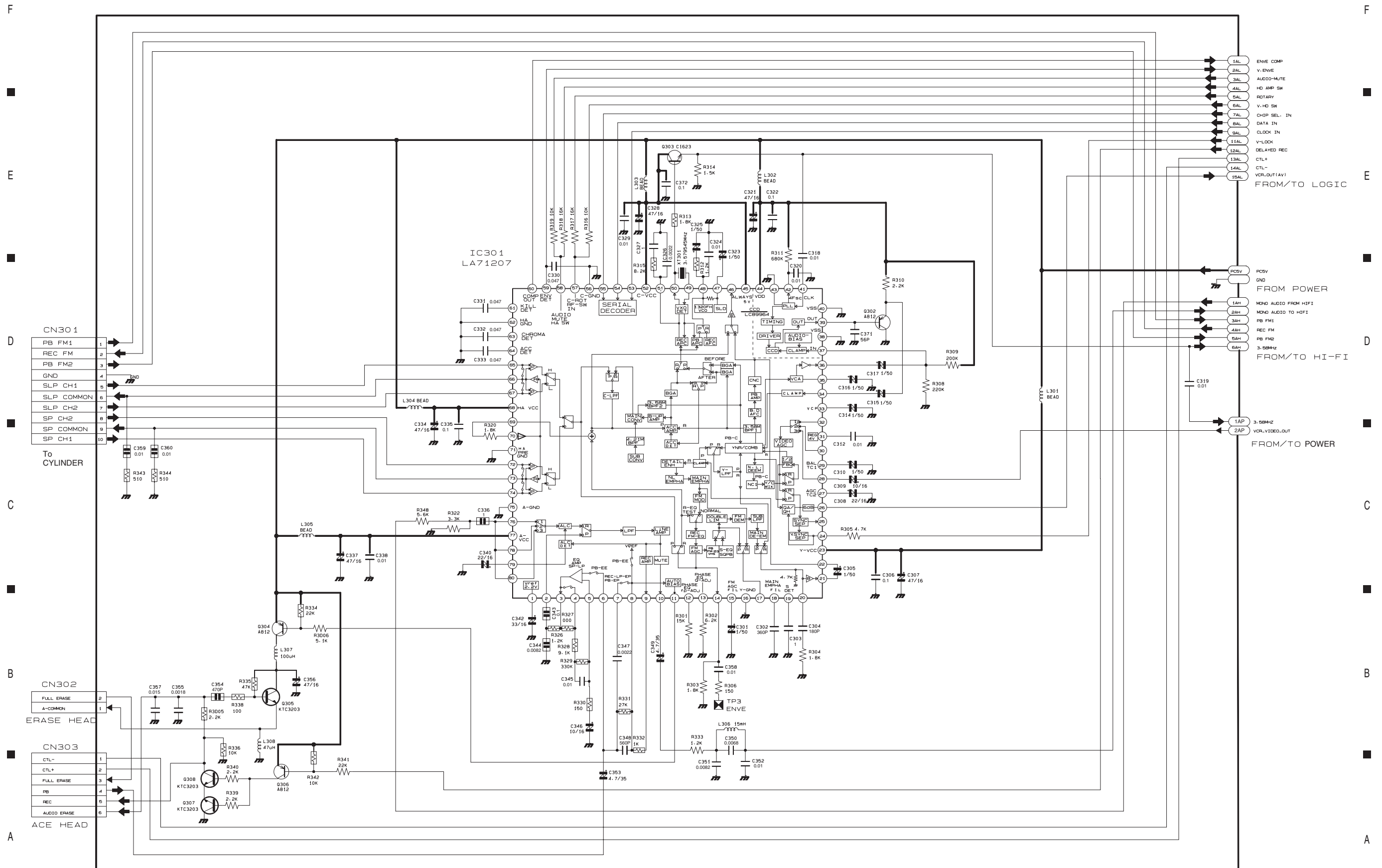

S-6 Hi-Fi/MTS Schematic Diagram (VCR Main P.C.B)

F

E

D

C

B

A

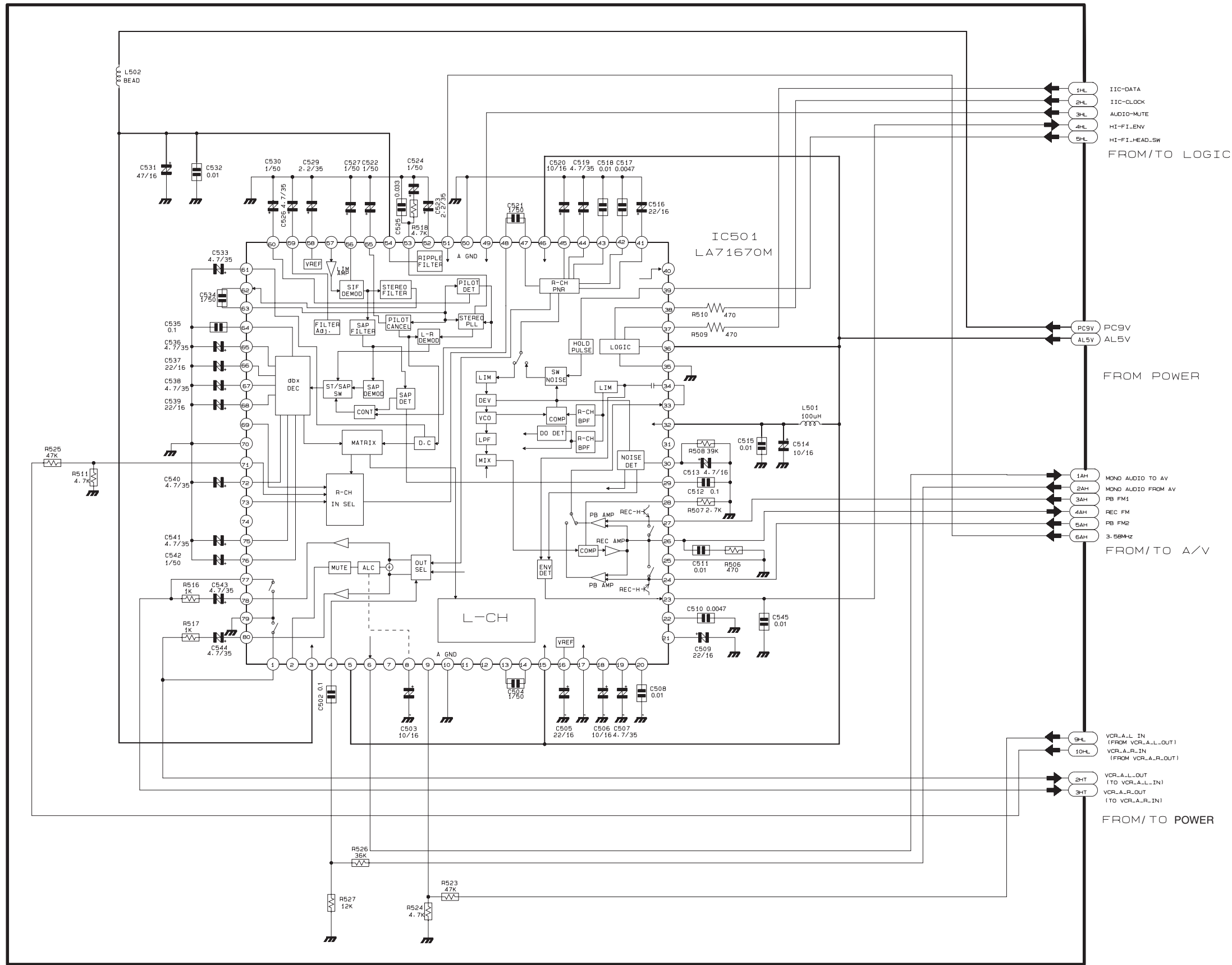

F

E

D

C

B

A

S-7 MUX & TM & A/V Input Schematic Diagram (Jack P.C.B)

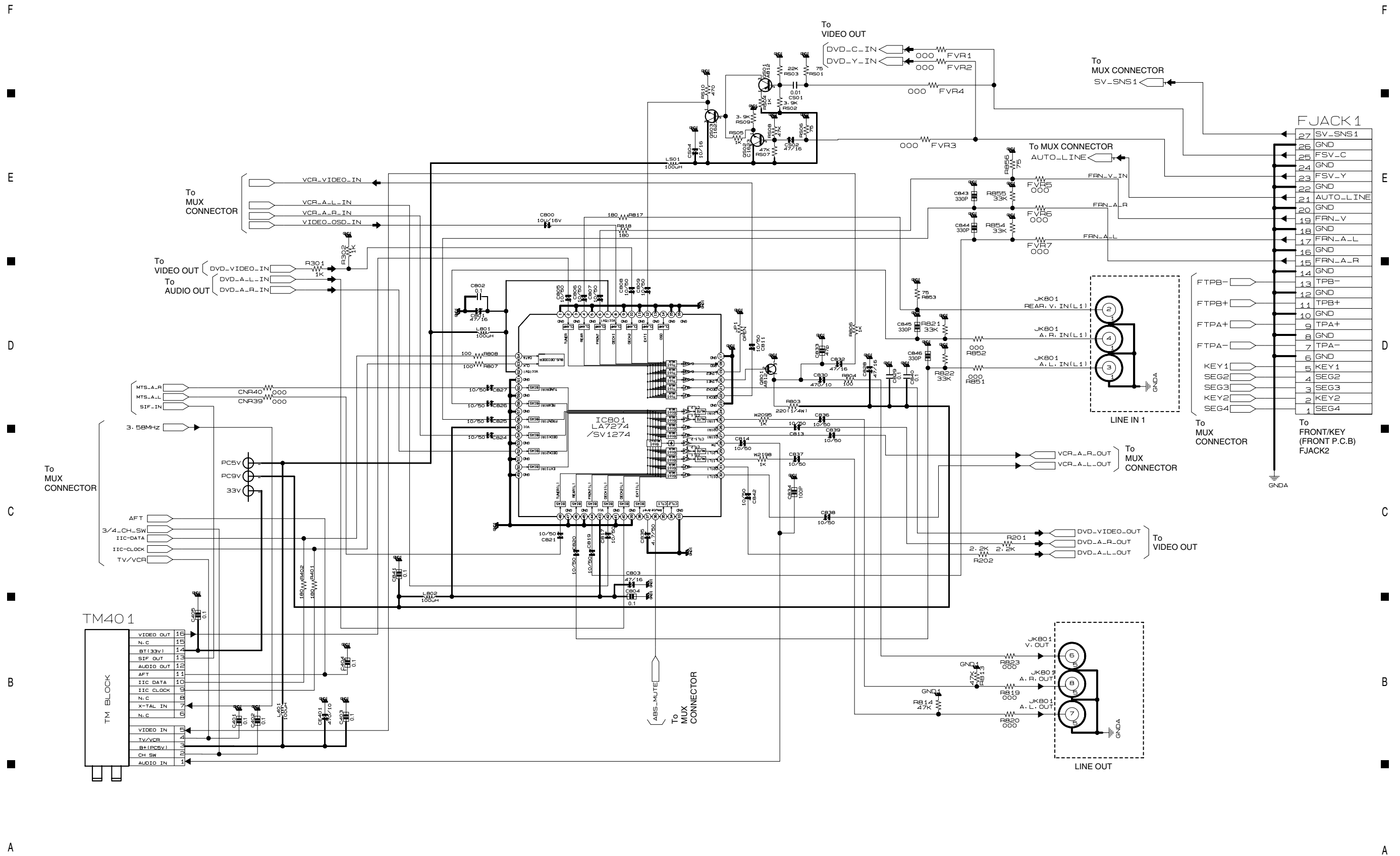

S-8 MUX Connector Schematic Diagram (Jack P.C.B)

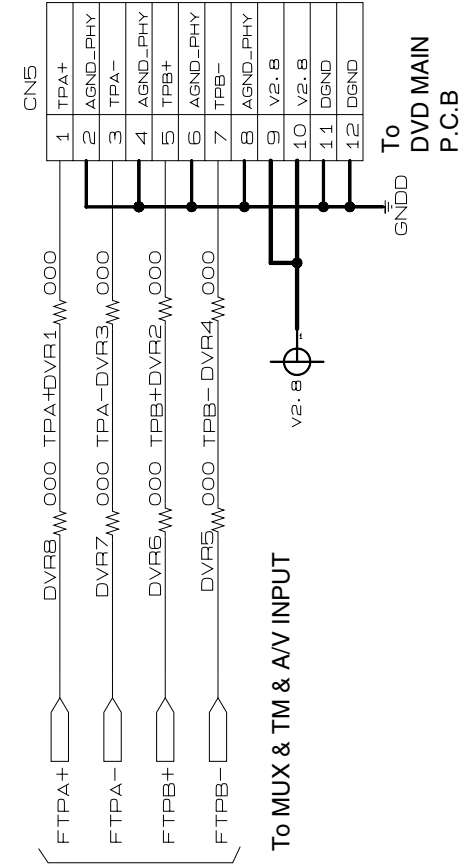
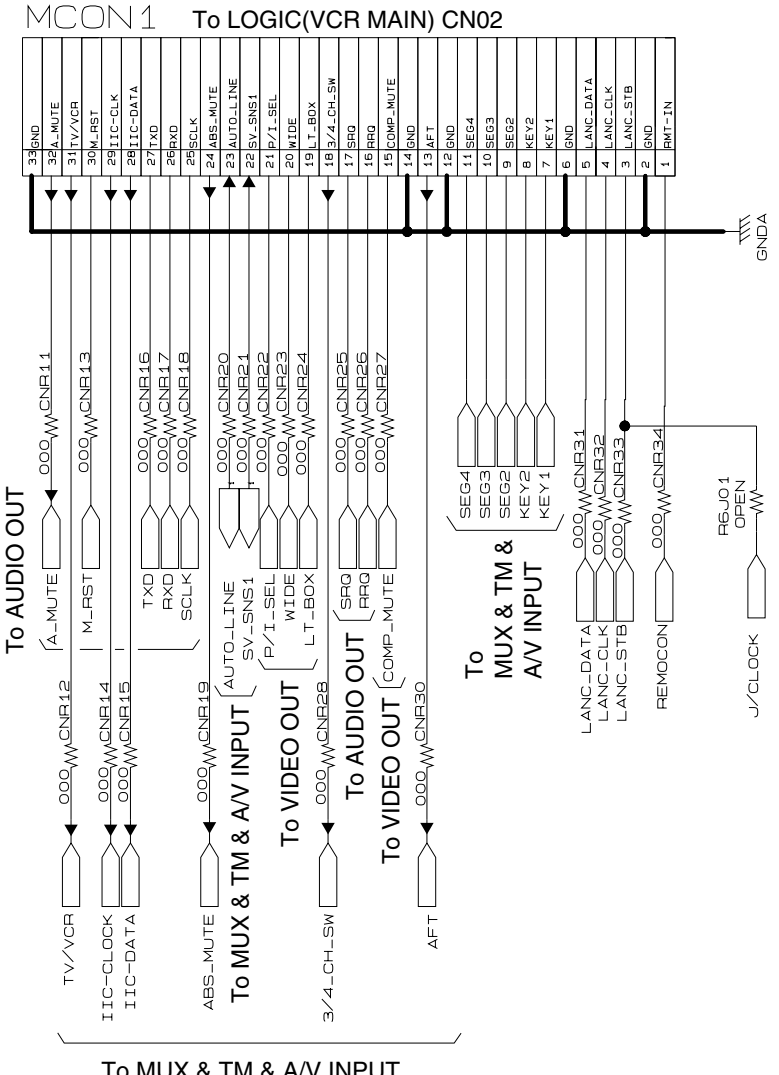
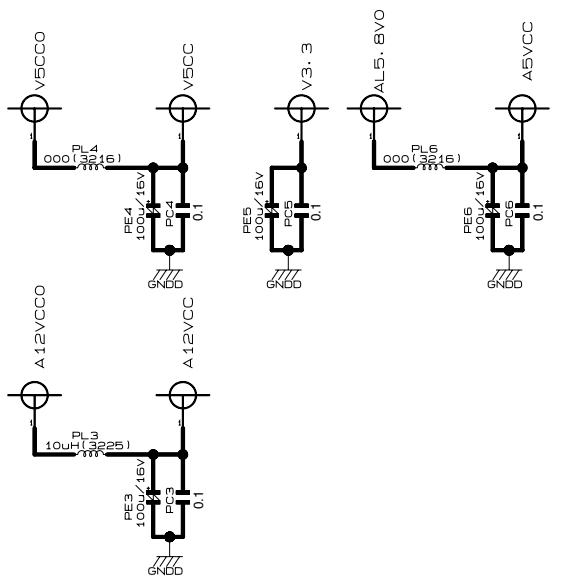
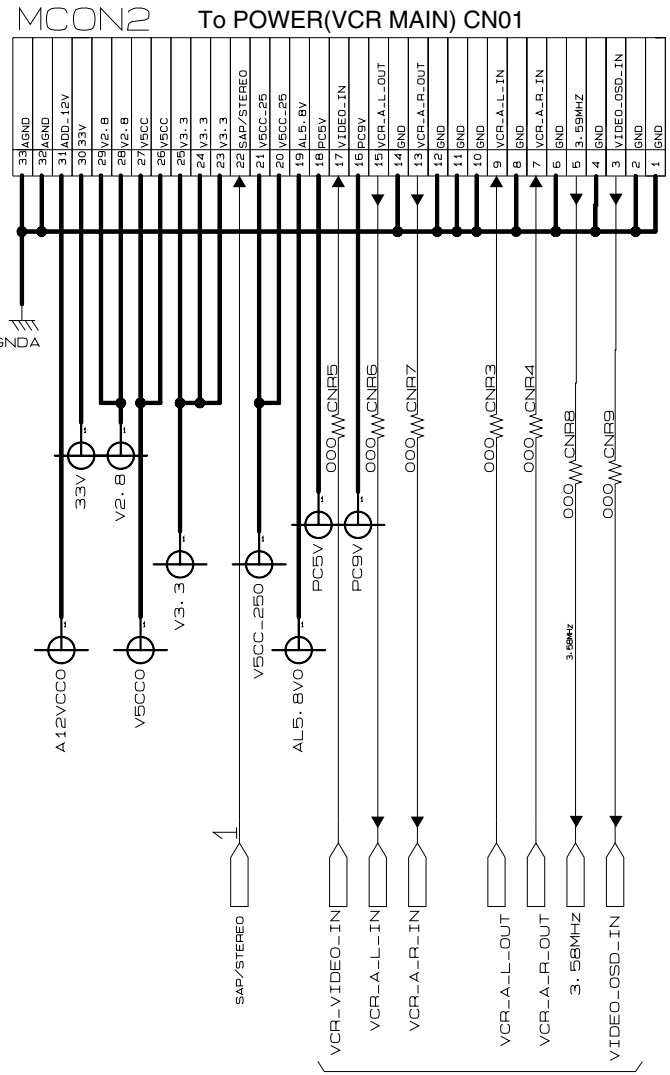

F
E
D
C
B
A

F
E
D
C
B
A

S-9 Audio Out Schematic Diagram (Jack P.C.B)

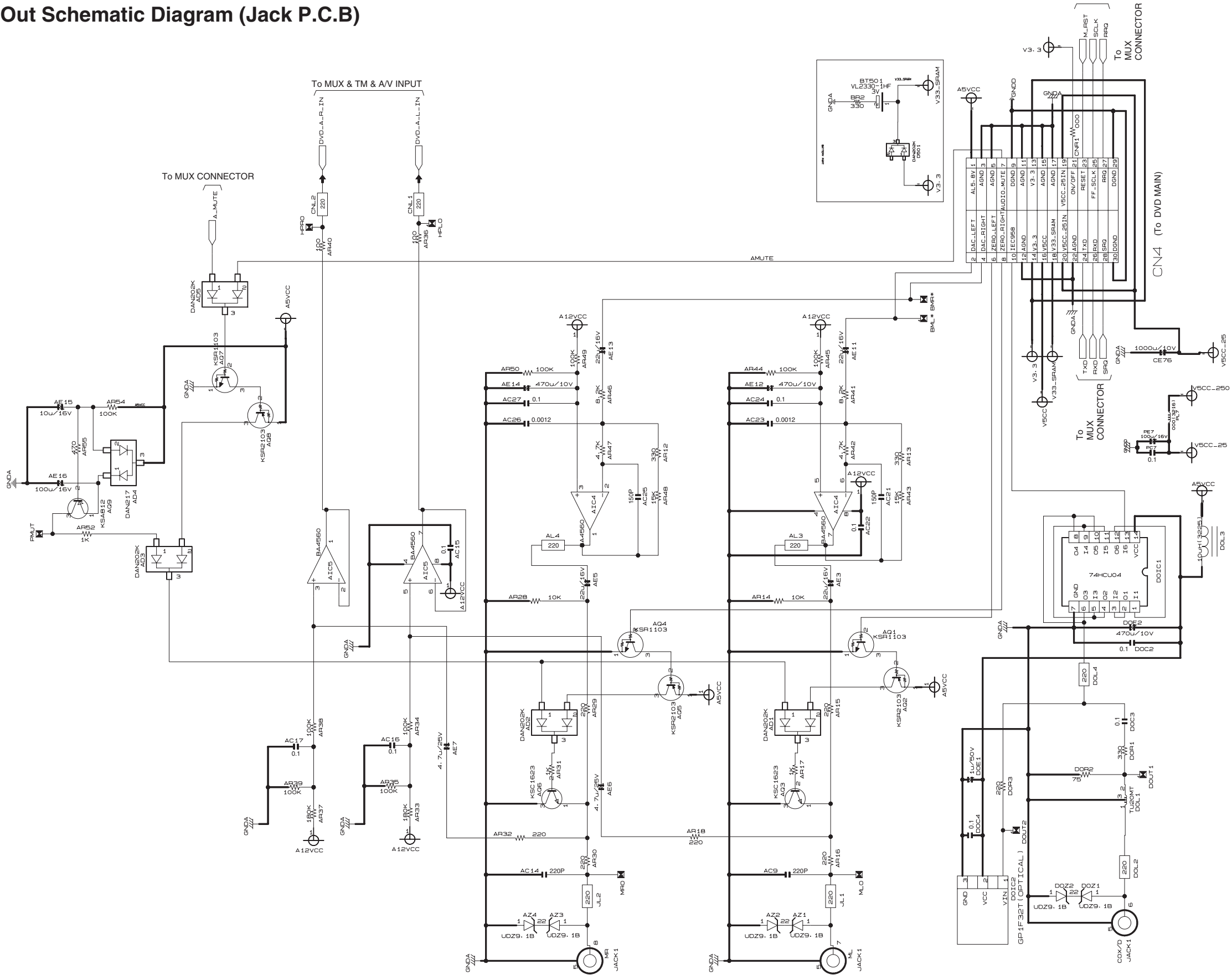

S-10 Video Out Schematic Diagram (Jack P.C.B)

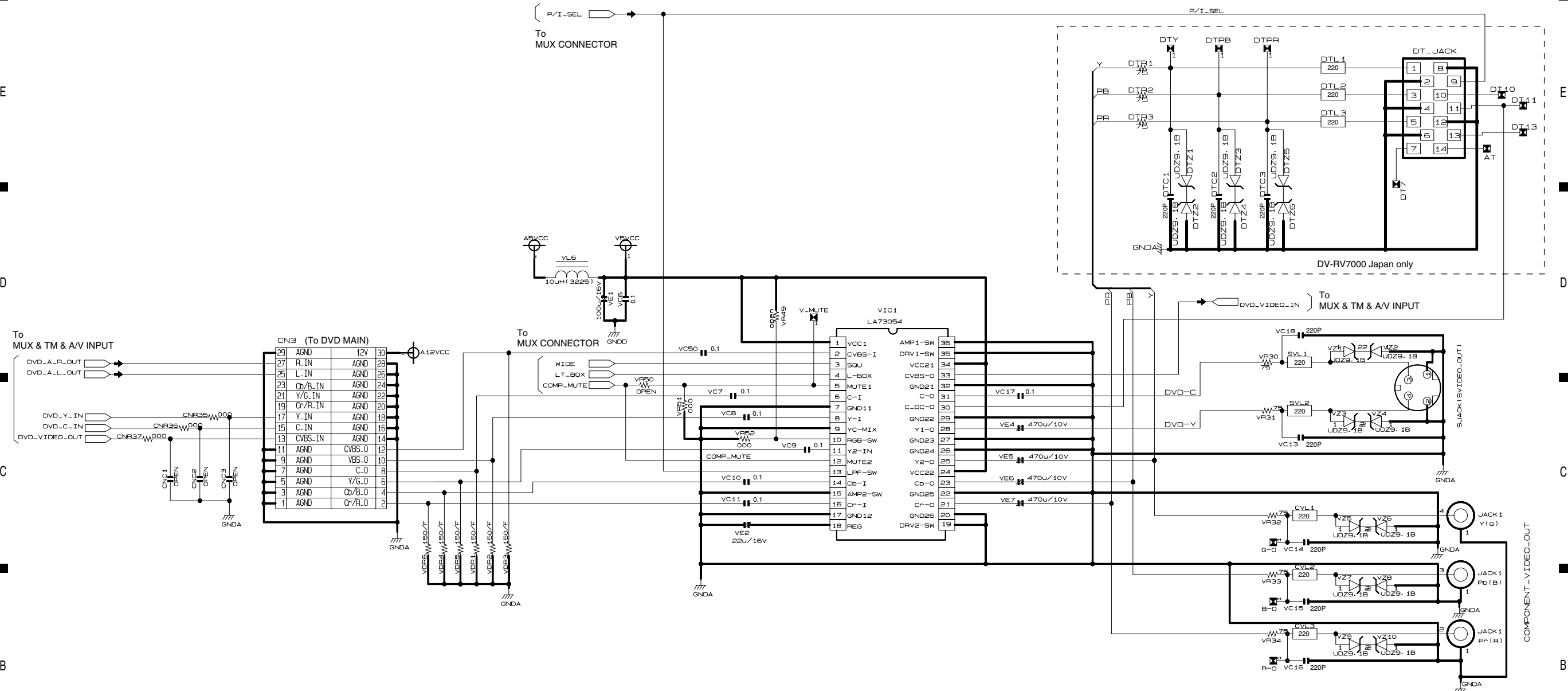

S-11 Front/Key Schematic Diagram (Front P.C.B)

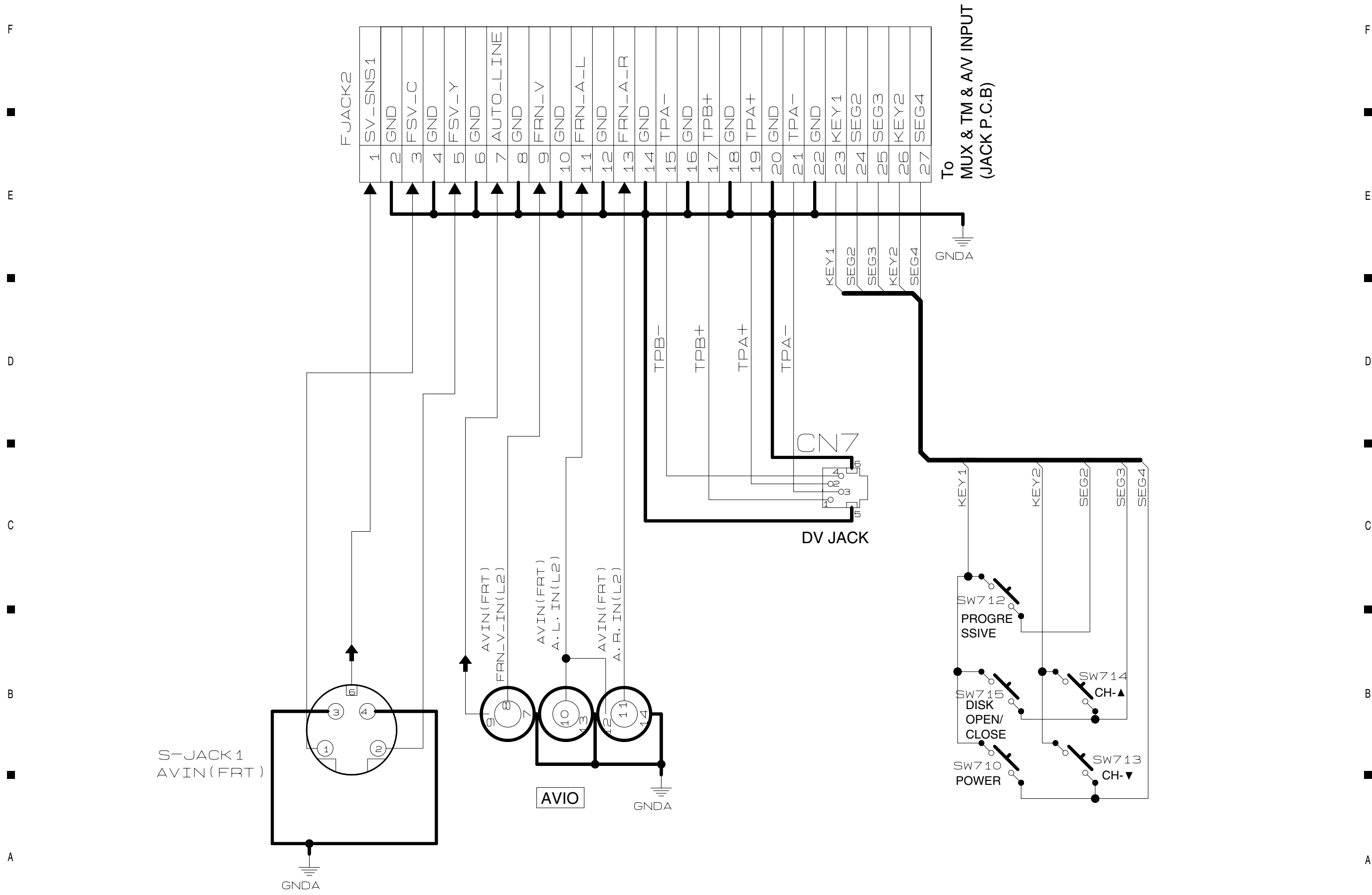

C CIRCUIT BOARD DIAGRAMS
C-1 VCR Main P.C.B

COMPONENT SIDE

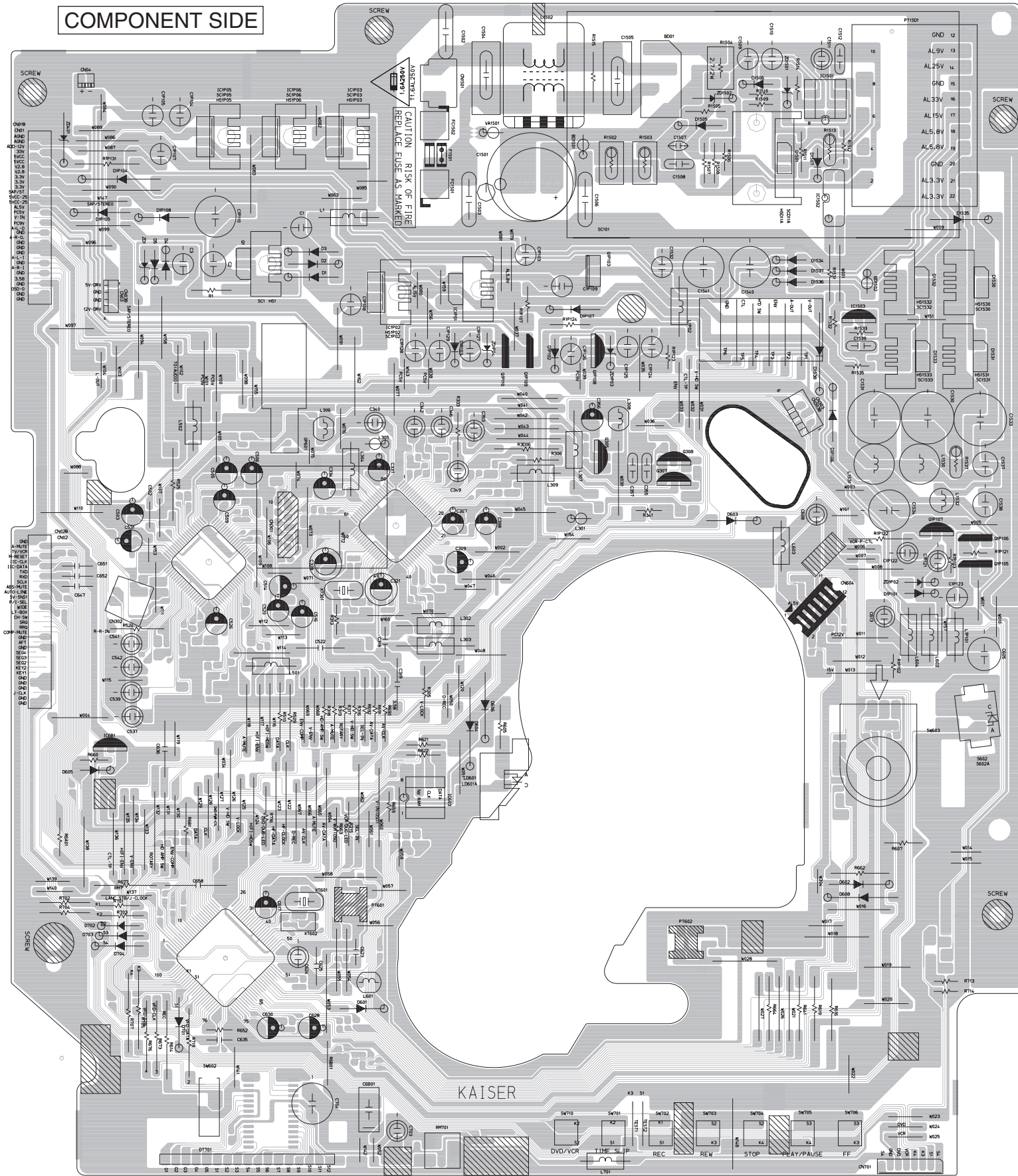

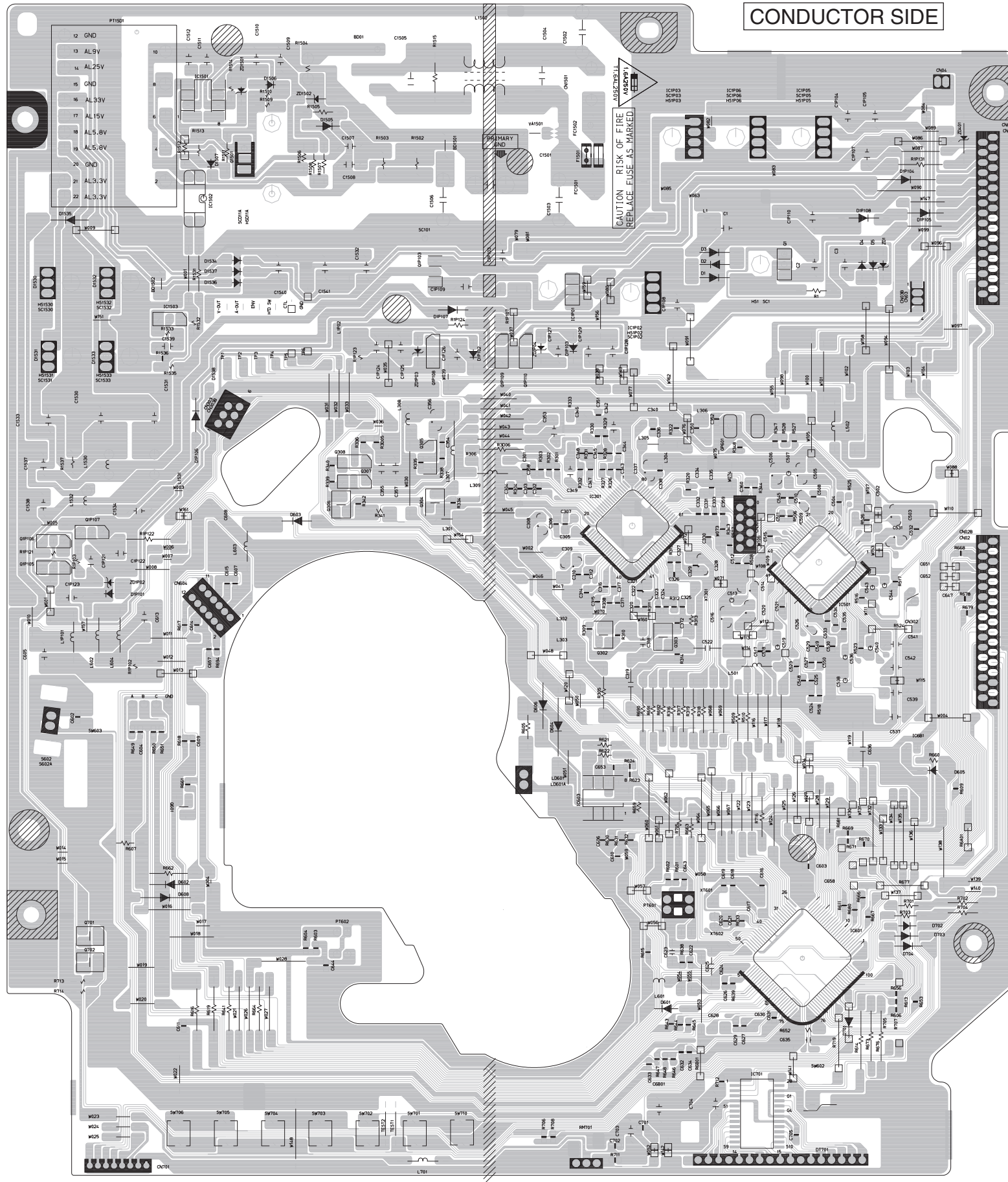

C-2 Jack P.C.B

COMPONENT SIDE

F

E

D

C

B

A

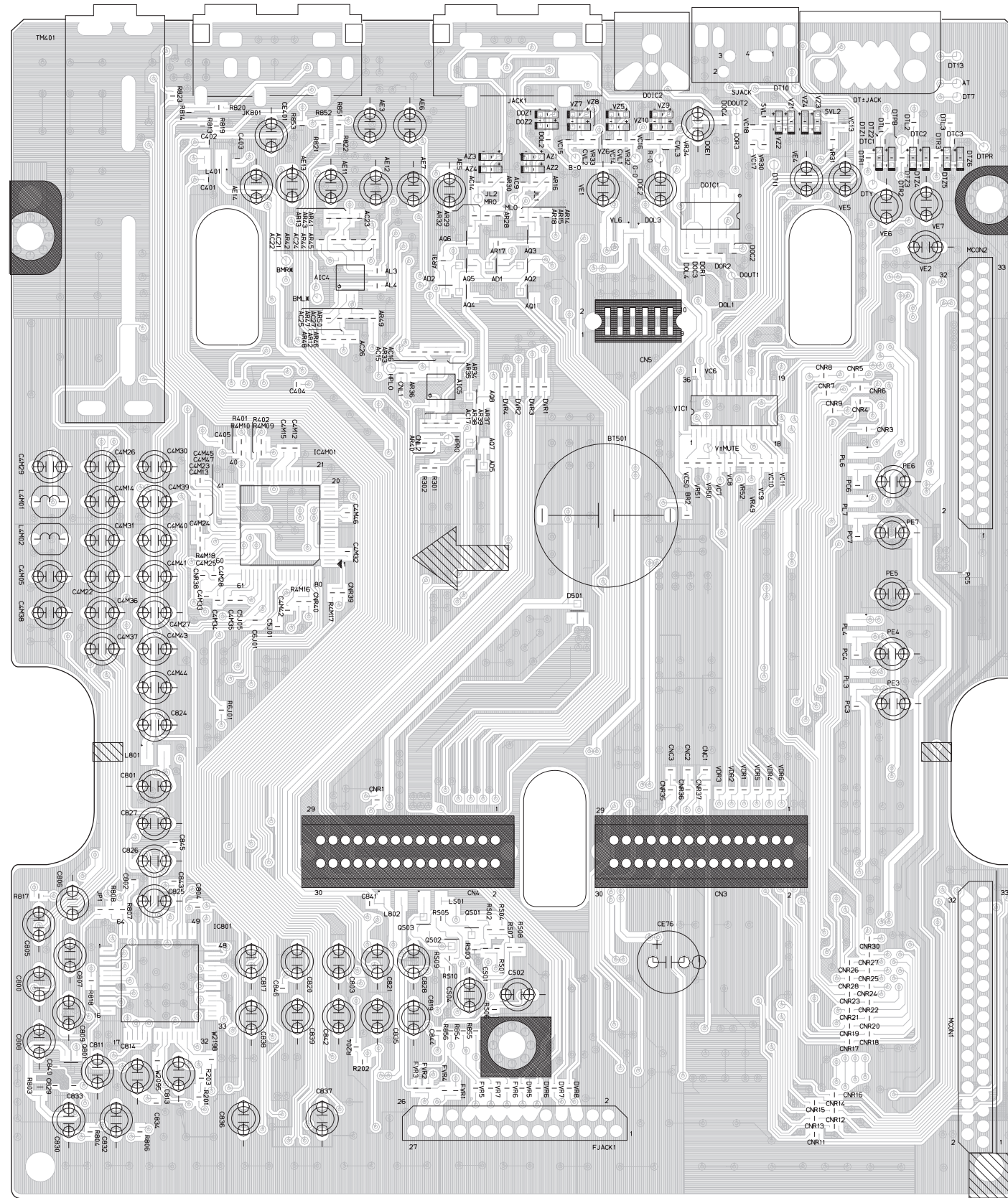

F

E

D

C

B

A

1

2

3

4

5

6

7

8

CONDUCTOR SIDE

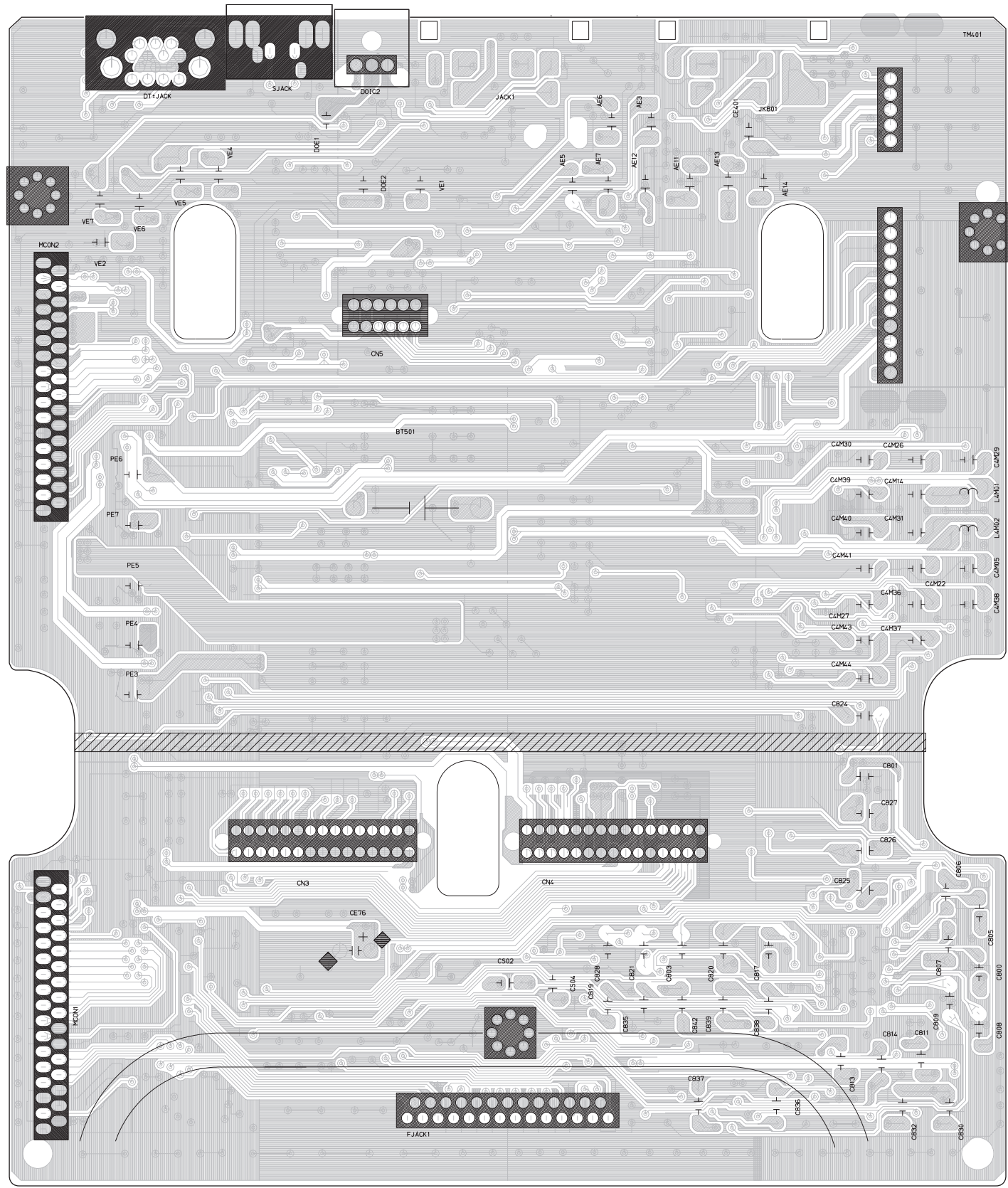

1

2

3

4

5

6

7

8

C-3 Front P.C.B

F

F

COMPONENT SIDE

CONDUCTOR SIDE

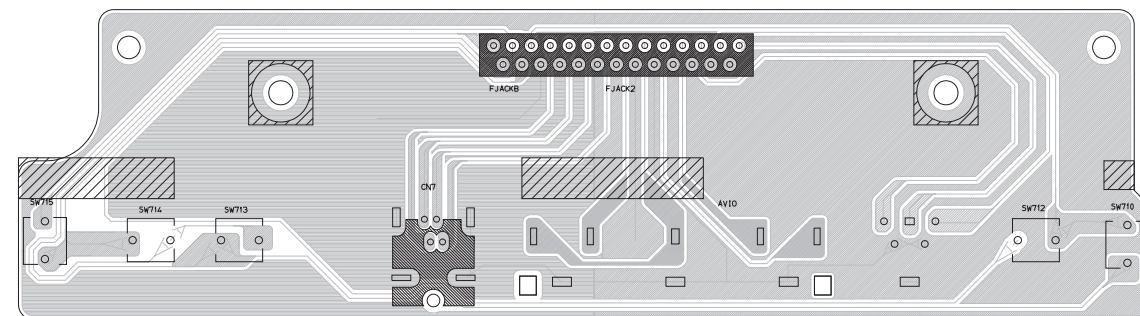
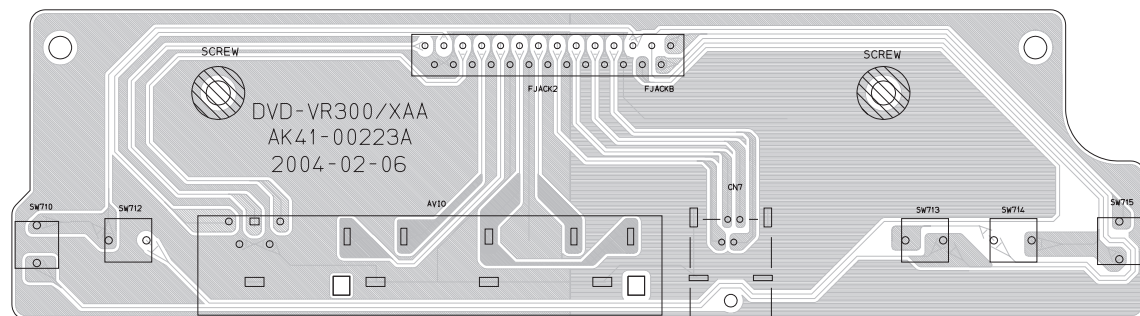

E

E

D

D

C-4 Key P.C.B

C

C

COMPONENT SIDE

CONDUCTOR SIDE

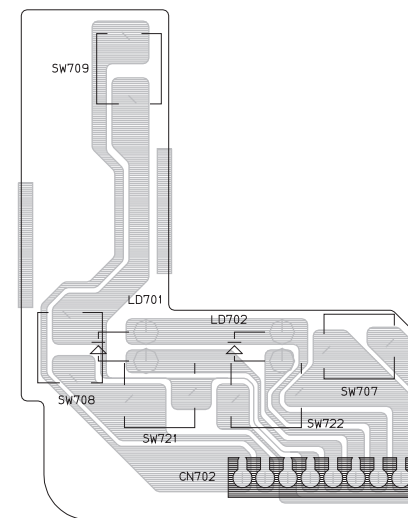
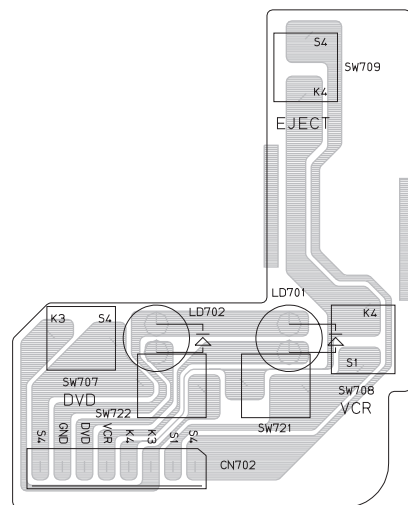

B

B

A

A

1

2

3

4

C - 5

5

6

7

8

B Block Diagram

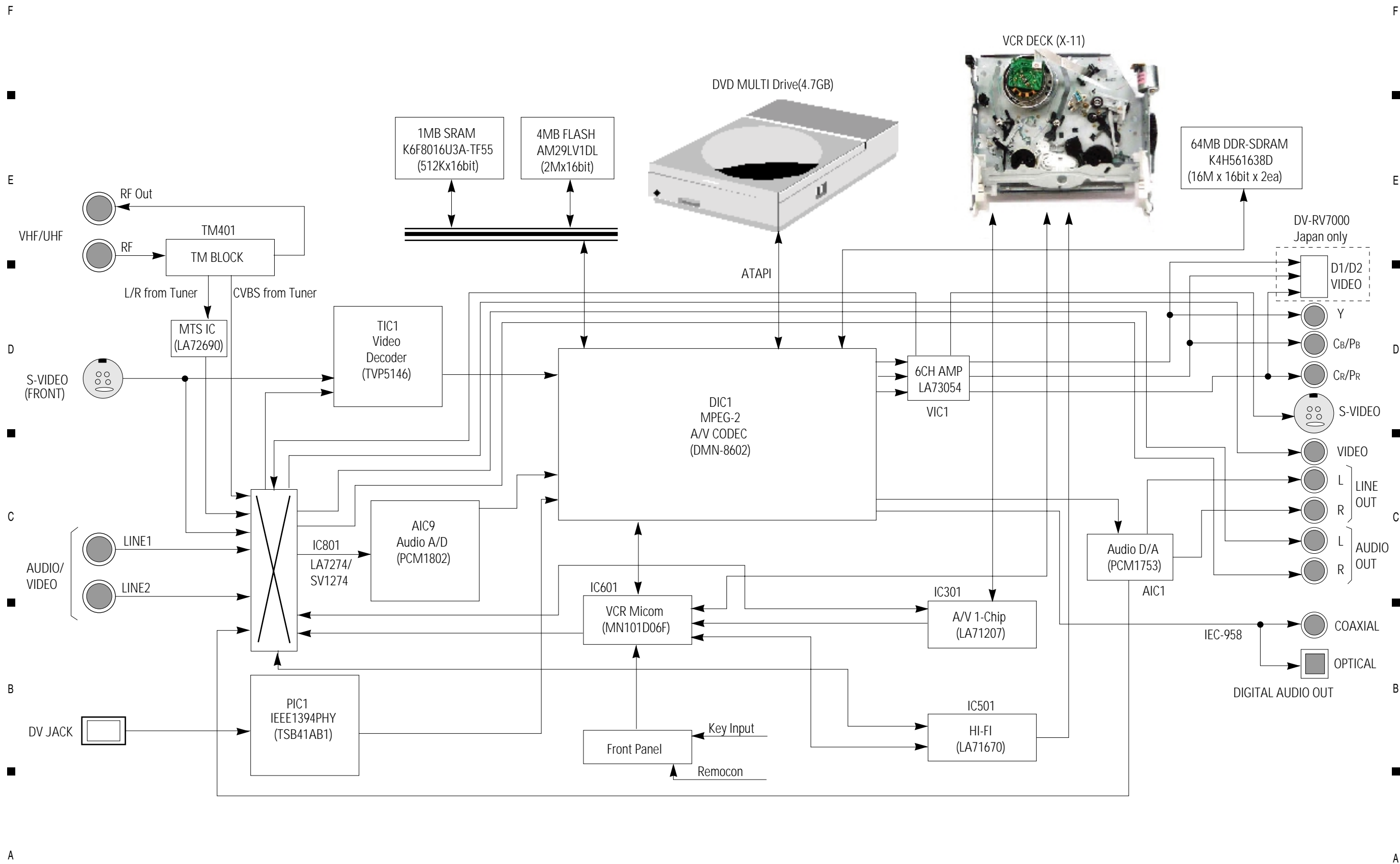

HITACHI