



HITACHI

SERVICE MANUAL

TY

No. 374 EGF

FT-2 FT-2L

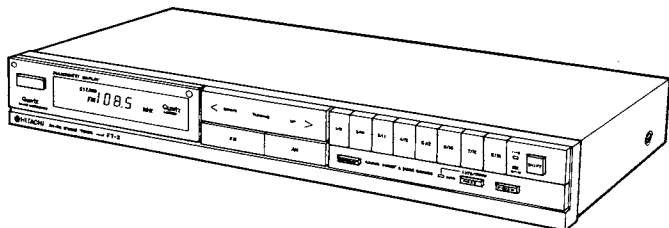

FT-2

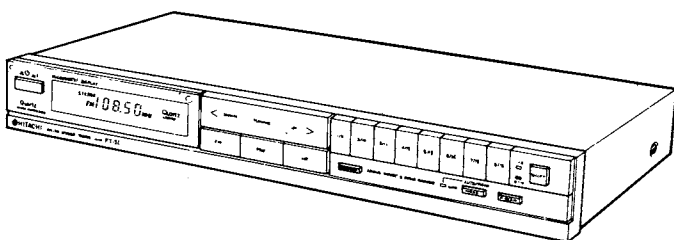

FT-2L

CONTENTS · INHALT · SOMMAIRE

SPECIFICATIONS · TECHNISCHE DATEN · CARACTÉRISTIQUES TECHNIQUES	2,3
FEATURES · MERKMALE · CARACTÉRISTIQUES	4,5
DISASSEMBLY AND REPLACEMENT · ZERLEGUNG UND AUSTAUSCH · DEMONTAGE ET REMONTAGE	5
GENERAL ALIGNMENT INSTRUCTIONS · ALLGEMEINE AUSTRICHTANLEITUNG · INSTRUCTIONS GENERALES	6
FM TUNER ALIGNMENT · ABGLEICH DES UKW-TUNERS · REGLAGE DE TUNER FM	6,7
AM TUNER ALIGNMENT · ABGLEICH DES AM-TUNERS · REGLAGE DU TUNER AM	8
PRINTED WIRING BOARD · PRINTPLATTEN · PLAN DE BASE	9,11
CIRCUIT DIAGRAM · SCHALTPLAN · PLAN DE CIRCUIT	10,12,13
BLOCK DIAGRAM · BLOCK SCHEMA · SCHEMA	13
REPLACEMENT PARTS LIST · ERSATZTEILISTE · TABLEAU DES PIECE	14 ~ 17
FRONT AND REAR PANEL · VORDERE UND HINTERE BEDIENUNGSTAFEL · PANNEAUX AVANT ET ARRIERE	18

SAFETY PRECAUTION

The following precautions should be observed when servicing.

1. Since many parts in the unit have special safety related characteristics, always use genuine Hitachi's replacement parts. Especially critical parts in the power circuit block should not be replaced with other makers. Critical parts are marked with Δ in the circuit diagram and printed wiring board.
2. Before returning a repaired unit to the customer, the service technician must thoroughly test the unit to ascertain that it is completely safe to operate without danger of electrical shock.

SICHERHEITSMASSNAHMEN

Bei Wartungsarbeiten sind die folgenden Sicherheitsmaßnahmen zu beachten:

1. Da verschiedene Teile dieses Gerätes Sicherheitsfunktionen aufweisen, nur Original-Hitachi-Ersatzteile verwenden. Kritische Teile im Netzteil sollten nicht durch ähnliche Teile anderer Hersteller ersetzt werden. Alle kritischen Teile sind im Schaltplan und im Diagramm der Schaltplattinen mit dem Symbol Δ gekennzeichnet.
2. Vor der Auslieferung eines reparierten Gerätes an den Kunden muß der Wartungstechniker das Gerät einer gründlichen Prüfung unterziehen, um sicherzustellen, daß sicherer Betrieb ohne die Gefahr von elektrischen Schlägen gewährleistet ist.

PRÉCAUTIONS DE SÉCURITÉ

Les précautions suivantes doivent être observées chaque fois qu'une réparation doit être faite.

1. Etant donné que de nombreux composants de l'appareil possèdent des caractéristiques relatives à la sécurité, utiliser uniquement des pièces de rechange d'origine Hitachi pour effectuer un remplacement. Ceci se rapporte notamment aux pièces critiques du bloc d'alimentation qui ne doivent en aucun cas être remplacées par celles d'autres fabricants. Les pièces critiques sont accompagnés du symbole Δ dans le schéma de montage et sur le schéma de plaque de câblage.
2. Avant de retourner l'appareil réparé au client le technicien doit procéder à un essai complet pour s'assurer qu'il ne présente aucun danger de chocs électriques.

SPECIFICATIONS AND PARTS ARE SUBJECT TO CHANGE FOR IMPROVEMENT.

AM/FM STEREO TUNER

June 1983

TOYOKAWA WORKS

SPECIFICATIONS

• FM SECTION

Frequency range	87.9 – 107.9MHz (100kHz steps) (for U.S.A. & Canada) 87.50 – 108.00MHz (50 kHz step) (for Europe, Asia & Latin American countries, etc.)
Sensitivity	10.8 dBf (IHF), 1.0 μ V (75 ohms DIN)
50 dB Quieting sensitivity	17.2 dBf (Mono) 39.2 dBf (Stereo)
Signal-to-noise-ratio	MONO : 75 dB (IHF) 65 dB (IEC, unweighted, Q-peak) 65 dB (IEC, weighted, Q-peak) STEREO : 68 dB (IHF) 62 dB (IEC, unweighted, Q-peak) 60 dB (IEC, weighted, Q-peak)
Total harmonic distortion	0.15 % (Mono), 0.3 % (Stereo)
Selectivity	55 dB (\pm 400 kHz IHF) (for U.S.A. & Canada) 70 dB (\pm 400 kHz IHF) 65 dB (\pm 300 kHz DIN) (for Europe, Asia & Latin American countries, etc.)
Frequency response	30 Hz – 15 kHz (\pm 2 dB) (except W. Germany) 30 Hz – 15 kHz (50 μ s \pm 1.0 dB) (for W. Germany)
Stereo separation	45 dB (1 kHz) (except W. Germany)
Capture ratio	1.0 dB
IF rejection ratio	75 dB
Image rejection ratio	45 dB
AM suppression ratio	56 dB
Output voltage	550 mV (1 kHz)
Antenna terminal	75 ohms unbalanced

• AM (MW) SECTION

Frequency range	530 – 1,620 kHz (10 kHz steps) (for U.S.A. & Canada) 522 – 1,611 kHz (9 kHz steps) (for Europe, Asia & Latin American countries, etc.)
Sensitivity	20 μ V (IHF), 200 μ V/m (IHF loop) 40 μ V (DIN)
Selectivity	30 dB
Signal-to-noise ratio	46 dB
Image rejection ratio	43 dB
IF rejection ratio	70 dB
Output voltage	165 mV (400 Hz, 30% modulation)

• LW SECTION [FT-2L]

Frequency range	146 – 353 kHz (1 kHz step)
Sensitivity	200 μ V (DIN)
Image rejection ratio	36 dB
Output voltage	165 mV (400 Hz, 30% modulation)

• GENERAL

Power requirements	AC 120V, 60 Hz (for U.S.A. & Canada) ~ 240V, 50 Hz (for Australia & U.K.) AC 110 – 120 V 60 Hz ~ 200 – 240 V 50/60 Hz (for Asia & Latin American countries, etc.) ~ 220V 50/60 Hz (for Europe)
Power consumption	7 watts
Dimensions [FT-2]	435(W) \times 60(H) \times 288(D) mm (12-5/8" \times 2-7/8" \times 9")
[FT-2L]	435(W) \times 60(H) \times 288(D) mm (12-5/8" \times 2-7/8" \times 11-3/8")
Weight	2.4 kg

TECHNISCHE DATEN

• UKW-TEIL

Empfangsbereich	87,9 bis 107,90 MHz (100 kHz Raster) (für USA und Kanada) 87,50 bis 108,0 MHz (50 kHz Raster) (für Europa, Asien und Lateinamerika)
Nutzempfindlichkeit	10,8 dBf (IHF), 1,0 μ V (75 Ohm DIN)
50 dB Geräuschberuhigung Rauschabstand	17,2 dBf (Mono) 39,2 dBf (Stereo) MONO : 75 dB (IHF) 65 dB (Fremdspannung- abstand) 65 dB (Geräuschspannung- abstand) STEREO : 68 dB (IHF) 62 dB (Fremdspannung- abstand) 60 dB (Geräuschspannung- abstand)
Gesamtklirrfaktor	0,15% (Mono), 0,3% (Stereo)

Trennschärfe

Trennschärfe	55 dB (\pm 400 kHz IHF) (für USA und Kanada) 70 dB (\pm 400 kHz IHF) 65 dB (\pm 300 kHz DIN) (für Europa Asien und Lateinamerika)
Stereo-Frequenzgang	30 Hz bis 15 kHz (\pm 2 dB) (ausgenommen die Bundesrepublik Deutschland) 30 Hz bis 15 kHz (50 μ s \pm 1.0 dB) (für die Bundesrepublik Deutschland)
Kanaltrennung	45 dB (1 kHz) (ausgenommen die Bundesrepublik Deutschland)
Gleichwellenselektion	1,0 dB
ZF-Unterdrückung	75 dB
Spiegelfrequenzsicherheit	45 dB
AM-Unterdrückung	56 dB
Ausgangsspannung	550 mV (1 kHz/40 kHz Abweichung)
Antennenanschluß	75 Ohm unsymmetrisch

● **AM (MW) TEIL**
Empfangsbereich 530 bis 1620 kHz (10 kHz Raster)
 (für USA und Kanada)
 522 bis 1611 kHz (9 kHz Raster)
 (für Europa, Asien und Lateinamerika)
Nutzempfindlichkeit 20 µV (VHF) 200 µV/m (Rahmenantenne)
 40 µV (DIN)
Trennschärfe 30 dB
Fremdspannungsabstand 46 dB
Spiegelfrequenzsicherheit 43 dB
ZF-Unterdrückung 70 dB
Ausgangsspannung 165 mV (400 Hz, 30% Modulation)

○ **LW-TEIL [FT-2L]**
Empfangsbereich 146 bis 353 kHz (1 kHz) (1 kHz Raster)
Empfindlichkeit 200 µV (DIN)
Spiegelfrequenzsicherheit 36 dB
Ausgangsspannung 165 mV (400 Hz, 30% Modulation)
 ● **ALLGEMEINDATEN**
Netzspannung 110 V - 120 V, 60 Hz
 ~ 200 V - 240 V, 50/60 Hz
 ~ 220 V, 50/60 Hz (für Europa)
 ~ 240 V, 50 Hz (für Großbritannien)
Stromverbrauch 7 Watt
Abmessungen [FT-2] 435(B) × 60(H) × 288(T) mm
[FT-2L] 435(B) × 60(H) × 288(T) mm
Gewicht 2,4 kg

Änderungen der Konstruktion und technischen Daten bleiben im Sinne der ständigen Verbesserung vorbehalten.

CARACTÉRISTIQUES TECHNIQUES

● **SECTION FM**
Gamme de fréquence 87,0 - 107,9 MHz
 (paliers de 100 kHz)
 (pour les Etats-Unis et le Canada)
 87,50 - 108,00 MHz
 (paliers de 50 kHz)
 (pour l'Europe, l'Asie et l'Amérique Latine)
Sensibilité 10,8 dBf (IHF),
 10,0 µV (75 ohms DIN)
Seuil de sensibilité 50 dB 17,2 dBf (Mono) 39,2 dBf (Stereo)
Rapport signal/bruit MONO : 75 dB (IHF)
 65 dB (IEC, non pondéré,
 crête Q)
 65 dB (IEC, pondéré,
 Crête Q)
 STEREO : 68 dB (IHF)
 62 dB (IEC, non pondéré,
 crête Q)
 60 dB (IEC, pondéré,
 crête Q)
Distorsion harmonique totale 0,15% (Mono), 0,3% (Stéréo)
Sélectivité 55 dB (±400 kHz IHF)
 (pour les Etats-Unis et le Canada)
 70 dB (±400 kHz IHF)
 65 dB (±300 kHz DIN)
 (pour l'Europe l'Asie et l'Amérique Latine)
Réponse en fréquence 30 Hz - 15 kHz (±2 dB)
 (sauf pour l'Allemagne de l'Ouest)
 30 Hz - 15 kHz (50 µs ^{+1,0} -6,0 dB)
 (pour l'Allemagne)
Séparation stéréo 45 dB (1 kHz)
 (sauf pour l'Allemagne de l'Ouest)
Taux de capture 1,0 dB
Taux de réjection FI 75 dB
Taux de réjection image 45 dB
Taux de suppression AM 56 dB

Tension de sortie 550 mV (1 kHz)
Borne d'antenne 75 ohms, asymétriques
 ● **SECTION AM (MW)**
Gamme de fréquence 530 - 1620 kHz (paliers de 10 kHz)
 (pour les Etats-Unis et le Canada)
 522 - 1611 kHz (paliers de 9 kHz)
 (pour l'Europe, l'Asie et l'Amérique Latine)
Sensibilité 20 µV (IHF), 200 µV/m (cadre IHF)
 40 µV (DIN)
Selectivité 30 dB
Rapport signal/bruit 46 dB
Taux de réjection image 43 dB
Taux de réjection FI 70 dB
Tension de sortie 165 mV (400 Hz, modulation de 30 %)
 ● **SECTION LO (LW)**
Gamme de fréquence 146 - 353 kHz (paliers de 1 kHz)
Sensibilité 200 µV (DIN)
Taux de réjection image 36 dB
Tension de sortie 165 mV (400 Hz, modulation de 30 %)
 ● **GENERAL**
Alimentation CA 120 V, 60 Hz
 (pour les Etats-Unis et le Canada)
 ~ 250 V, 50 Hz (pour l'Australie)
 CA 110 - 120 V, 60 Hz
 ~ 200 - 240 V, 50/60 Hz
 (pour les l'Asie et l'Amérique Latine)
 ~ 220 V 50/60 Hz (pour l'Europe)
 ~ 240 V 50 Hz (pour G.B.)
Consommation 7 watts
Dimensions [FT-2] 435(L) × 60(H) × 288(P) mm
[FT-2L] 435(L) × 60(H) × 288(P) mm
Poids 2,4 kg

Les spécifications et la conception sont sujettes à modifications sans préavis pour des raisons d'amélioration.

FEATURES

QUARTZ SYNTHESIZED TUNING USING A MICROCOMPUTER

The tuning drift is suppressed as far as possible using a high precision crystal oscillator and PLL (phase locked loop) circuit, and at the same time, controlled by the microcomputer, so precise reception is possible. The reception frequency range and the step frequency are shown in the table below.

	FM section		AM (MW) section		LW section (FT-2L)	
	Frequency range	Step frequency	Frequency range	Step frequency	Frequency range	Step frequency
U.S.A., Canada	87.9 - 107.9 MHz	100 kHz	530 - 1620 kHz	10 kHz	-	-
Europe, Asia and Latin America	87.5 - 108.0 MHz	50 kHz	522 - 1611 kHz	9 kHz	146 - 353 kHz	1 kHz

● 16-STATION RANDOM PRESET MEMORY

The random preset memory using the shift key system can memorize up to a total of 16 FM and AM stations.

● PRESET SCANNING SYSTEM

Each of the preset channels is received for 5 seconds in sequence making it convenient to check the contents of each broadcast.

● PRESET CHANNEL, FREQUENCY DISPLAY ON FL

The reception frequency and the preset channel etc. are displayed by a 2-color fluorescent display, so tuning is easy.

MERKMALE

Quarz-Synthesizer-Tuner mit Mikrocomputer

Die Senderwahl erfolgt mit Hilfe eines Kristall-Oszillators und einer phasenstarrten Servo-Schleife (PLL) in Verbindung mit einem Mikrocomputer, der ein Ausdriften des einmal eingestellten Senders verhindert. In der nachfolgenden Tabelle sind die Empfangsbereiche und die entsprechenden Rasterschritte aufgeführt.

	UKW-Empfangsteil		MW-Empfangsteil		LW-Empfangsteil (FT-2L)	
	Empfangsbereich	Rasterschritt	Empfangsbereich	Rasterschritt	Empfangsbereich	Rasterschritt
USA, Kanada	87,9 - 107,9 MHz	100 kHz	530 - 1620 kHz	10 kHz	-	-
Europa, Asien und Latein-Amerika	87,5 - 108,0 MHz	50 kHz	522 - 1611 kHz	9 kHz	146 - 353 kHz	1 kHz

● Festsendertasten für bis zu 16 Stationen

In Verbindung mit den Festsendertasten gestattet der eingebaute Mikroprozessor die Speicherung von insgesamt 16 UKW und LW/MW-Stationen, die danach auf Tastendruck abgerufen werden können.

● Festsender-Suchlauffunktion

Die voreingestellten Festsender werden aufeinanderfolgend für jeweils 5 Sekunden empfangen, wodurch die einzelnen Rundfunkprogramme überprüft werden können.

● Anzeige für Empfangsfrequenz und Festsenderkanal

Die Empfangsfrequenz, die festsenderkanal usw. werden in der zweifarbigen Fluoreszenz-Digital-Anzeige angezeigt, wodurch die Senderwahl wesentlich erleichtert wird.

CARACTÉRISTIQUES

Accord synthétisé à quartz utilisant un microordinateur

Les écarts d'accord sont supprimés dans leur presque totalité grâce à l'adoption d'un oscillateur à cristal de haute précision et d'un circuit en phase (PLL) en même temps qu'un contrôle opéré par microordinateur de sorte que des conditions de réception très précises peuvent être réunies. La gamme de fréquence de réception et les tranches de fréquence sont indiquées dans le tableau ci-dessous.

	Etage FM		Etage AM (PO)		Etage GO (FT-2L)	
	Gamme de fréquences	Tranche de fréquence	Gamme de fréquence	Tranche de fréquences	Gamme de fréquence	Tranche de fréquences
Etats-Unis, Canada	87,9 - 107,9 MHz	100 kHz	530 - 1620 kHz	10 kHz	-	-
Europe, Asie et Amérique Latine	87,5 - 108,0 MHz	50 kHz	522 - 1611 kHz	9 kHz	146 - 353 kHz	1 kHz

• **Mémoire de préaccord à accès direct de 16 stations**

La mémoire de préaccord à accès direct utilise un système de sélection par touches et est capable de retenir jusqu'à 16 stations FM et AM.

• **Système de balayage pré réglé**

Chacun des canaux pré réglés est reço pendant 5 secondes suivant un cycle séquentiel et ceci permet de contrôler sans difficulté la teneur de chaque programme.

• **Canal préaccordé sur panneau d'affichage de fréquence FL**

La fréquence de réception et la canal préaccordé, ainsi que d'autres informations, apparaissent sur un panneau d'affichage fluorescent bicolore de sorte que l'accord est largement facilité.

DISASSEMBLY AND REPLACEMENT · ZERLEGUNG UND AUSTAUSCH · DEMONTAGE ET REMONTAGE

- **Removing the printed wiring boards**
- **Ausbau der Leiterplatten**
- **Déposer des plaquettes à circuit imprimé**

1. Cover
· Remove ① screws (X2)
2. Front panel
· Remove ② screws (X4) and ③ screws (X1)
3. Control P.W.B.
· Remove ④ screws (X4)
4. TU P.W.B.
· Remove ⑤ screws (X6) and ⑥ screw (X3)

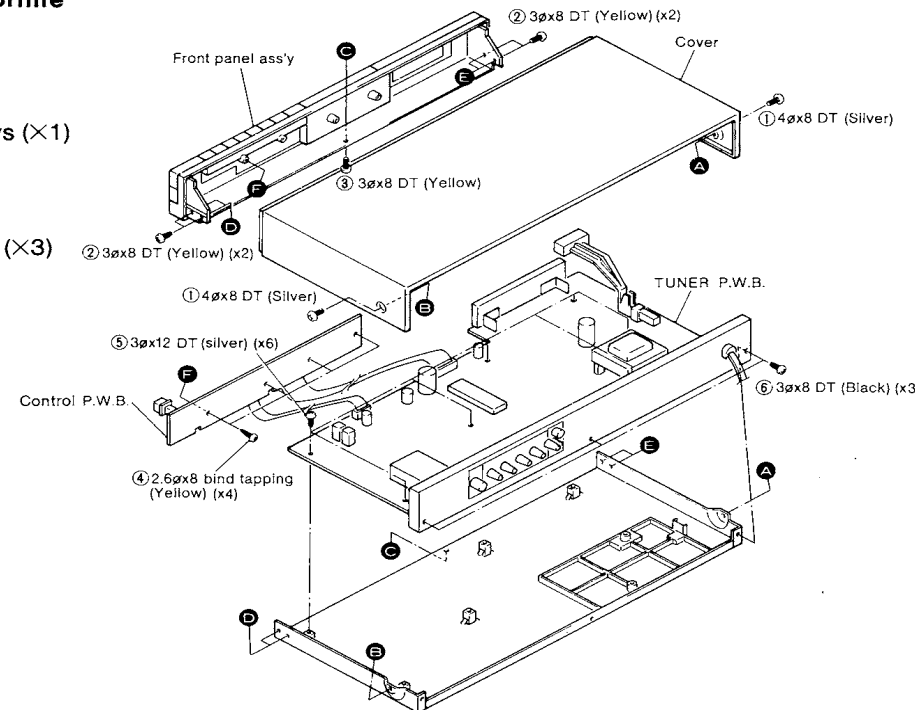

GENERAL ALIGNMENT INSTRUCTIONS · ALLGEMEINE AUSRICHTANLEITUNG · INSTRUCTIONS GENERALES

- **ADJUSTING POINTS**
- **EINSTELLPUNKT**
- **POINT DE REGLAGE**

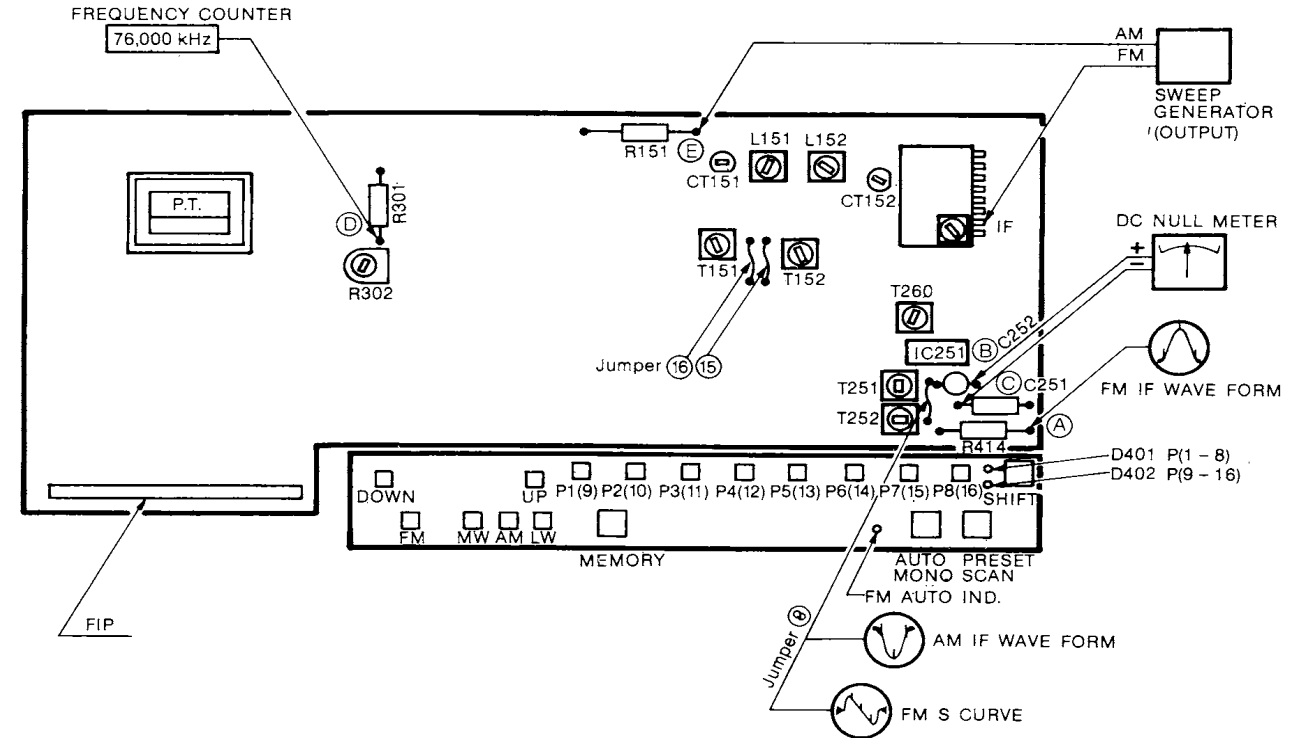

FM TUNER ALIGNMENT · ABGLEICH DES UKW-TUNERS · REGLAGE DE TUNER FM

- Ⓢ Sweep Generator Wobbelgenerator Générateur de balayage
- Ⓢ Signal Generator Signalgenerator Générateur de signaux
- Ⓢ Oscilloscope Oszilloskop Oscilloscope
- Ⓢ DC Null Meter Gleichstrom-Nullmeter Indicateur d'équilibrage à C.C.
- Ⓢ VTM V.T.V.M. Voltmètre électronique
- Ⓢ Frequency Counter Frequenzzähler Fréquence-mètre
- Ⓢ Dist. Distortion Meter Klirrmesser Distorsionmètre

Sequence Folge Ordre	Connection Anschlüsse Connexion		Setting Einstellung Montage		Adjust for Einstellung für Réglage pour	
	Input Eingang Entrée	Output Ausgang Sortie	Tuning Abstimm-anzeige Indicateur d'accord	Signal Signal	Adjust Einstellpunkt Réglage	Indication Anzeigte Indication
1	Tuner Pack IF Terminal	Tuner IN P.W.B. Eingang R414 ① 100k 0.1μ	—	10.7 MHz	IFT (Tuner pack)	(Note. 2) (Anm. 2)
2	—	IN Jumper ⑧ 100k 0.1μ	—	10.7 MHz	T251 : "S" curve T252 : Straight line	Straight line Gerade Line Ligne Droite (Note 3) (Hinweis 3)

**AM TUNER ALIGNMENT · ABGLEICH DES AM-TUNERS ·
REGLAGE DU TUNER AM**

3	Discriminator Diskriminator Discriminateur	ANT. Terminal 75 ohms		98.00 MHz	98.00 MHz	T251	(Note 4) (Anm. 4)
4	Distortion Verzerrung Distorsion	60 dBμ 1 kHz, 75 kHz (dev.) (for U.S.A. Canada) 40 kHz (dev.) (except U.S.A. Canada)	Output Terminal 	98.00 MHz	98.00 MHz	T252	Distortion min (Note 5) (Anm. 5)
5	76 kHz Free running Freilauf Exploration libre	ANT. Terminal 75 ohms 60 dBμ Non Mod.	Tuner P.W.B. R301 	98.00 MHz	98.00 MHz	R302	76 kHz : 120 Hz

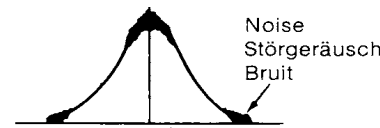

Fig. 4
Abb. 4

- (Note 1) Perform adjustment at least 3 minutes after the power has been switched on.
 (Note 2) Using a sweep generator, apply low-input signals (with a small amount of noise superimposed as in Fig. 4), and adjust the tuner pack's IFT so that the waveforms are brought to their maximum in center marker frequency (10.7 MHz).
 (Note 3) Adjust the T251 coil and obtain an S-curve. Now adjust the T252 coil and improve the Linearity of the S-curve.
 (Note 4) Connect a DC null meter across C252 (B) and C251 (C) on the tuner P.W.B. and adjust T251 core for a reading of 0 V ±60 mV.
 (Note 5) When the distortion adjustment is performed, there will be a slight deviation in the discriminator adjustment performed under 3. Therefore, repeat adjustments 3 and 4 several times and adjust for a reading of 0 V on the DC null meter with the distortion at its minimum.

* All adjustments in the FM tuner section are done before shipping and so, it is not necessary to adjust Covering and Tracking.

- (Anmerk. 1) Einstellungen erst nach mehr als 3 Minuten Einschaltzeit vornehmen.
 (Anmerk. 2) Niedrige Eingangssignale (mit kleineren überlagerten Rauscheffekten nach Abb. 4) durch Anwendung eines Oszillators einspeisen und die IFT des Tunerpacks so justieren, daß die Frequenzwellen ihr Maximum in der Mittelbereichsfrequenz (10,7 MHz) erreichen.
 (Anmerk. 3) Durch Justierung der T251-Spule wird eine S-Kurve erzeugt. Anschließend die T252-Spule justieren um die Linearität der S-Kurve zu vervollkommen.
 (Anmerk. 4) Einen Gleichstrom-Nullzähler an C252 (B) und C251 (C) der Tuner-Leiterplatte anschließen und den T251 auf eine Anzeige von 0 V ±60 mV einstellen.
 (Anmerk. 5) Nach Durchführung der Regulierung des Klirrfaktors, ergibt sich eine leichte Abweichung der unter 3 durchgeführten differenzierten Einstellung; die Einstellungen 3 und 4 aufgrund dessen mehrmals wiederholen und zur Anzeige von 0 V auf dem Gleichstrom-Nullzähler bei minimaler Verzerrung einstellen.

* Alle Einstellungen des UKW-Empfangsteils wurden werksseitig vor dem Versand ausgeführt, so daß Bereich und Nachführung nicht eingestellt werden müssen.

- (Note 1) Effectuer le réglage 3 minutes au moins après que l'appareil ait été mis sous tension.
 (Note 2) Lorsque l'on utilise un générateur de balayage, envoyer des signaux de faible entrée (avec une petite quantité de parasites surimposés, comme indiqué sur la figure 4), et régler le transformateur de fréquence intermédiaire (IFT) de façon que les formes d'onde atteignent leur maximum à la fréquence du point central (10,7 MHz).
 (Note 3) Régler la bobine T251 de façon à obtenir une courbe en S. Puis régler la bobine T252 de façon à améliorer la linéarité de la courbe en S.
 (Note 4) Relier un compteur de zéro CC à la P.W.B. du tuner en passant par C252 (B) et C251 (C), puis régler de façon à obtenir 0 V ±60 mV à l'affichage pour l'âme T251.
 (Note 5) Lorsque le réglage de la distorsion est effectué, il se produira une légère déviation dans le réglage dans le discriminateur effectué en 3. En conséquence, recommencer plusieurs fois les étapes 3 et 4 de façon à obtenir 0 V sur le compteur CC de zéro avec une distorsion minimum.

* Tous les réglages de la section tuner FM ont été effectués avant l'envoi de l'appareil de sorte que les réglages de couverture et de syntonisation ne sont plus à faire.

Condition Function : AM Modulation : 400 Hz 30%
 Bedingung Funktion : AM Modulation : 400 Hz 30%
 Conditions. Foncton : AM Modulation : 400 Hz 30%

Sequence Folge Ordre	Connection Anschlüsse Connexion		Setting Einstellung Montage		Adjust for Einstellung für Réglage pour	
	Input Eingang Entrée	Output Ausgang Sortie	Tuning Abstimm- anzeige Indicateur d'accord	Signal Signal Signal	Adjust Einstellpunkt Réglage	Indication Indication Indication
1	Tuner P.W.B. R151 	IN Eingang Entrée OUT Ausgang Sortie 	—	450 kHz	T260	 (Note 1) (Anmerk. 1)
2	Loop antenna Rahmenantenne Antenne en cadre	MW Jumper (16) LW Jumper (15) Tuner P.W.B. 	(MW) 522 kHz (LW) 146 kHz	(MW) 1.75 V (LW) 1.95 V	(MW) T151 (LW) T152	(Note 2) (Anmerk. 2)
3	Tracking Vorstufe Alignement	OUTPUT 	(MW) 603 kHz (LW) 164 kHz (MW) 1404 kHz (LW) 353 kHz	(MW) 603 kHz (LW) 164 kHz (MW) 1404 kHz (LW) 335 kHz	L151 L152 CT151 CT152	V max. (Note 3) (Anmerk. 3)

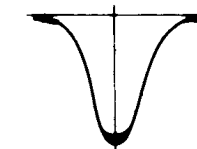

Fig. 5
Abb. 5

- (Note 1) Adjust the cores of T260 so that the waveform is as shown in Fig. 5.
 (Note 2) Connect a DC null meter across Jumper (16) / MW, (15) / LW and GND (Tuner pack case) pin on the tuner P.W.B. and adjust the core of T151 (T152). Furthermore, carry out this adjustment for final adjustment of the coil only when you have moved the core by mistake.
 (Note 3) Set the input level to 74 dB in coarse adjustment. Reduce the input level to minimum (50 dB) as adjustment proceeds.

- (Anmerk. 1) Die Kerne von T260 so einstellen, daß die in Abb. 5 dargestellte Wellenform erhalten wird.
 (Anmerk. 2) Ein Gleichspannungs-Nullmeter an Überbrückung (16) / MW, Überbrückung (15) / LW und GRN (Tunerpackgehäuse) Stife der Tuner-Leiterplatte anschließen und den Kern von T151 (T152) einstellen. Diese Einstellung zur abschließen den Abgleichung der Spule dann vornehmen, wenn der Kere irrtümlich verstellt wurde.
 (Anmerk. 3) Den Eingangspegel auf 74 dB grob einstellen. Nach Durchführung der Einstellungen den Eingangspegel auf Minimum (50 dB) zurückstellen.

- (Note 1) Régler les âmes de T266 de façon à obtenir une forme d'onde comme indiquée sur la Fig. 5.
 (Note 2) Relier un compteur de zéro CC à la P.W.B. du tuner en passant par la connexion intermédiaire (16) / PO, la intermédiaire (15) / GO et GND (bloc Tuner) et régler l'âme de T151 (T152) N'effectuer le dernier réglage de la bobine par ce réglage que si vous avez bougé l'âme par erreur.
 (Note 3) Faire un réglage approximatif du niveau d'entrée à 74 dB. Réduire le niveau d'entrée jusqu'à un minimum de 50 dB à mesure que l'on effectue le réglage.

PRINTED WIRING BOARD · PRINTPLATTEN · PLAN DE BASE

FT-2

[■ : Earth, ■ : Other]

- * : Axial lead cylindrical ceramic capacitor
- * : Zylindrischer Keramikkondensator mit axialer Zuleitung
- * : Condensateur céramique cylindrique à conducteur axial

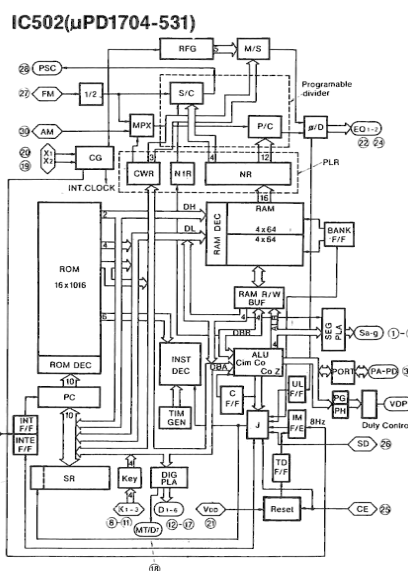
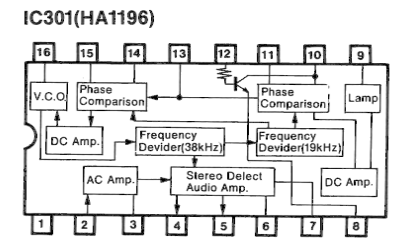
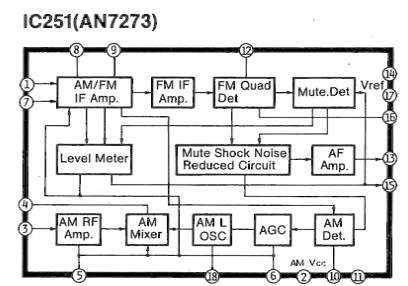
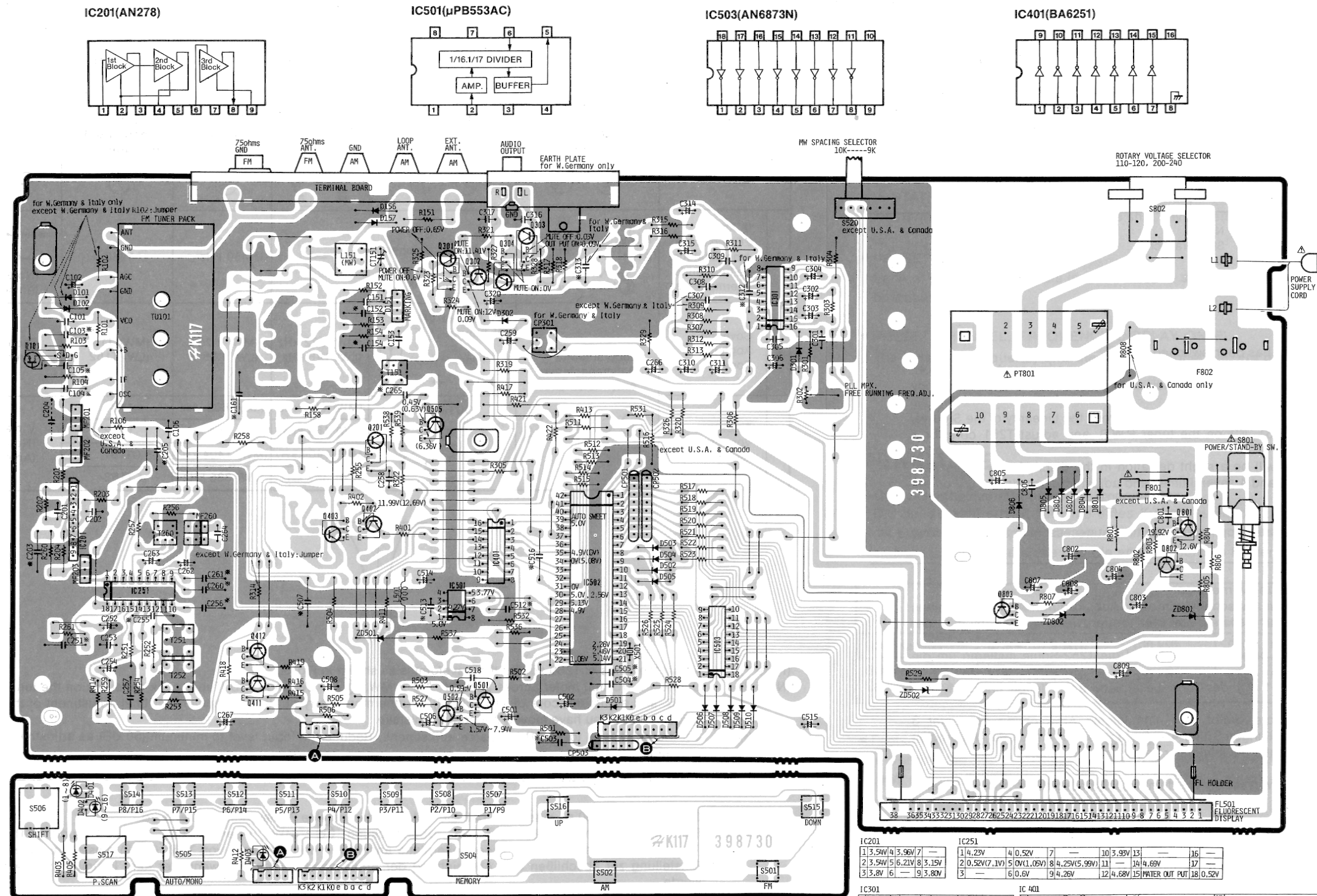

IC201		IC251		IC301		IC401	
1	3.59V	4	3.96V	7	—	10	5.99V
2	3.59V	5	6.21V	8	3.15V	11	14
3	3.8V	6	—	9	3.80V	12	4.69V
						13	17
						14	18
						15	18
						16	18
						17	18
						18	18
						19	18
						20	18
						21	18
						22	18
						23	18
						24	18
						25	18
						26	18
						27	18
						28	18
						29	18
						30	18
						31	18
						32	18
						33	18
						34	18
						35	18
						36	18
						37	18
						38	18

CIRCUIT DIAGRAM · SCHALTPLAN · PLAN DE CIRCUIT

FT-2

CAUTION
Use the electrolytic capacitors with explosion-proof valve when the diameter of them is more than 10mmφ.

- * : Axial lead cylindrical ceramic capacitor
- * : Zylindrischer Keramikkondensator mit axialer Zuleitung
- * : Condensateur céramique cylindrique à conducteur axial

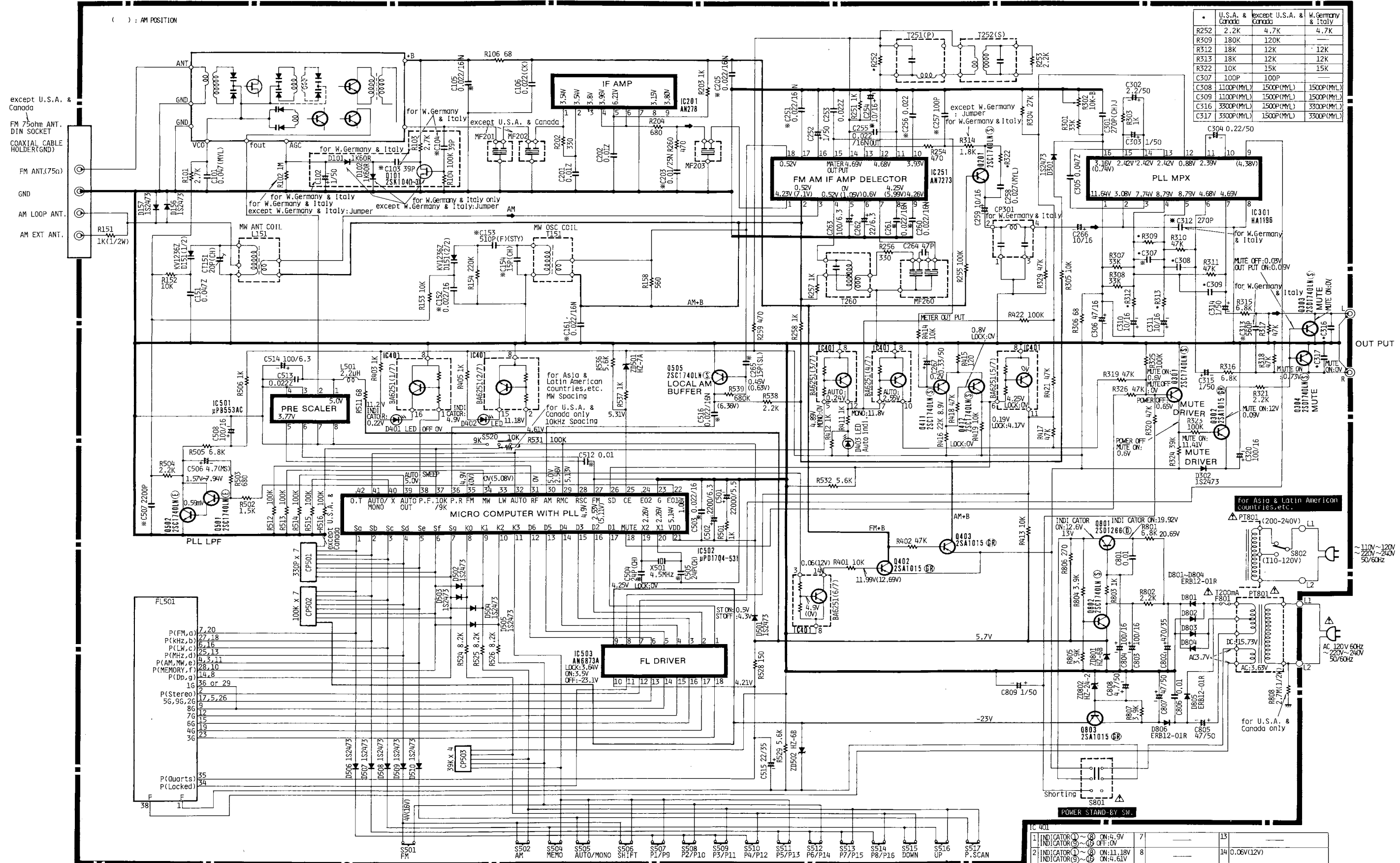

	U.S.A. & Canada	except U.S.A. & Canada	W.Germany & Italy
R252	2.2K	4.7K	4.7K
R309	180K	120K	
R312	18K	12K	12K
R313	18K	12K	12K
R322	10K	15K	15K
C307	100P	100P	
C308	1100P(MYL)	1500P(MYL)	1500P(MYL)
C309	1100P(MYL)	1500P(MYL)	1500P(MYL)
C316	3300P(MYL)	1500P(MYL)	3300P(MYL)
C317	3300P(MYL)	1500P(MYL)	3300P(MYL)

IC 401	1	2	3	4	5	6	7	8	9	10	11	12	13	14	15	16
INDICATOR ①	ON: 4.5V	OFF: 0V														
INDICATOR ②	ON: 11.18V	OFF: 0V														
INDICATOR ③	ON: 4.61V	OFF: 0V														

PRINTED WIRING BOARD · PRINTPLATTEN · PLAN DE BASE

FT-2L

[■ : Earth, ■ : Other]

- * : Axial lead cylindrical ceramic capacitor
- * : Zylindrischer Keramik Kondensator mit axialer Zuleitung
- * : Condensateur céramique cylindrique à conducteur axial

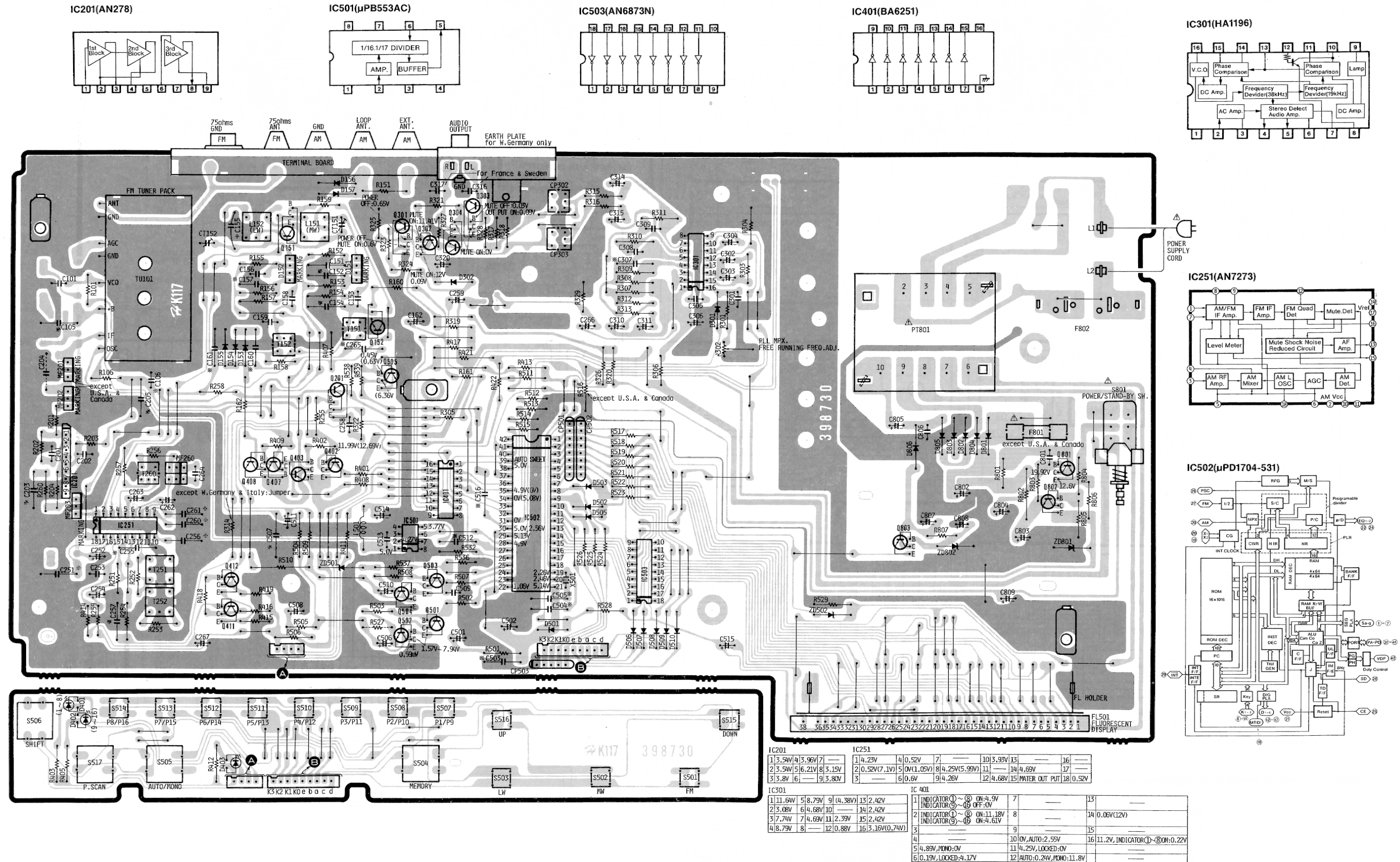

IC201				IC251			
1	3.54V	4	3.96V	7	—	10	3.95V
2	3.54V	5	6.21V	8	3.15V	11	—
3	3.8V	6	—	9	3.80V	12	4.68V
IC301				IC401			
1	11.64V	5	8.79V	9	4.38V	13	2.42V
2	3.08V	6	4.68V	10	—	14	2.42V
3	7.74V	7	4.69V	11	2.39V	15	2.42V
4	8.79V	8	—	12	0.88V	16	3.16V(7.4V)

IC502						
1	INDICATOR ①-⑧	ON:4.9V	7	—	13	—
2	INDICATOR ⑨-⑩	OFF:0V	8	—	14	0.06V(12V)
3	INDICATOR ⑪-⑫	ON:11.18V	9	—	15	—
4	—	ON:4.61V	10	—	16	11.2V, INDICATOR ①-⑧ ON:0.22V
5	4.89V, MONO:0V	—	11	4.25V, LOCKED:0V	—	—
6	0.19V, LOCKED:4.17V	—	12	AUTO:0.24V, MONO:11.8V	—	—

CIRCUIT DIAGRAM · SCHALTPLAN · PLAN DE CIRCUIT

FT-2L

CAUTION
Use the electrolytic capacitors with explosion-proof valve when the diameter of them is more than 10mmø.

- * : Axial lead cylindrical ceramic capacitor
- * : Zylindrischer Keramik Kondensator mit axialer Zuleitung
- * : Condensateur céramique cylindrique à conducteur axial

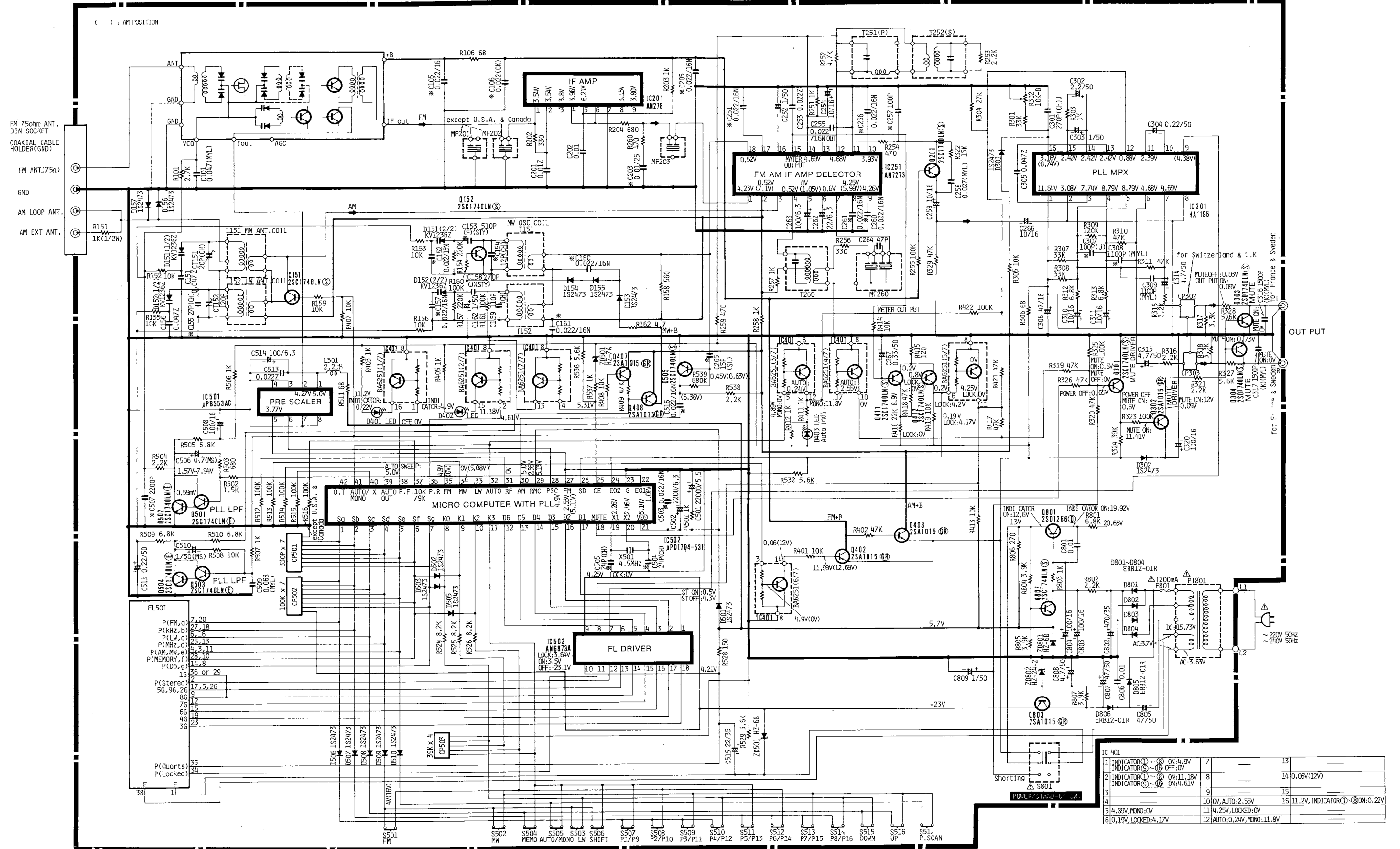

IC 401	INDICATOR	ON: 4.9V	OFF: 0V
1	INDICATOR ①	ON: 4.9V	OFF: 0V
2	INDICATOR ②	ON: 11.18V	OFF: 0V
3	INDICATOR ③	ON: 4.61V	OFF: 0V
4	INDICATOR ④	ON: 4.61V	OFF: 0V
5	INDICATOR ⑤	ON: 4.9V	OFF: 0V
6	INDICATOR ⑥	ON: 4.61V	OFF: 0V

CIRCUIT DIAGRAM · SCHALTPLAN · PLAN DE CIRCUIT

TUNER PACK

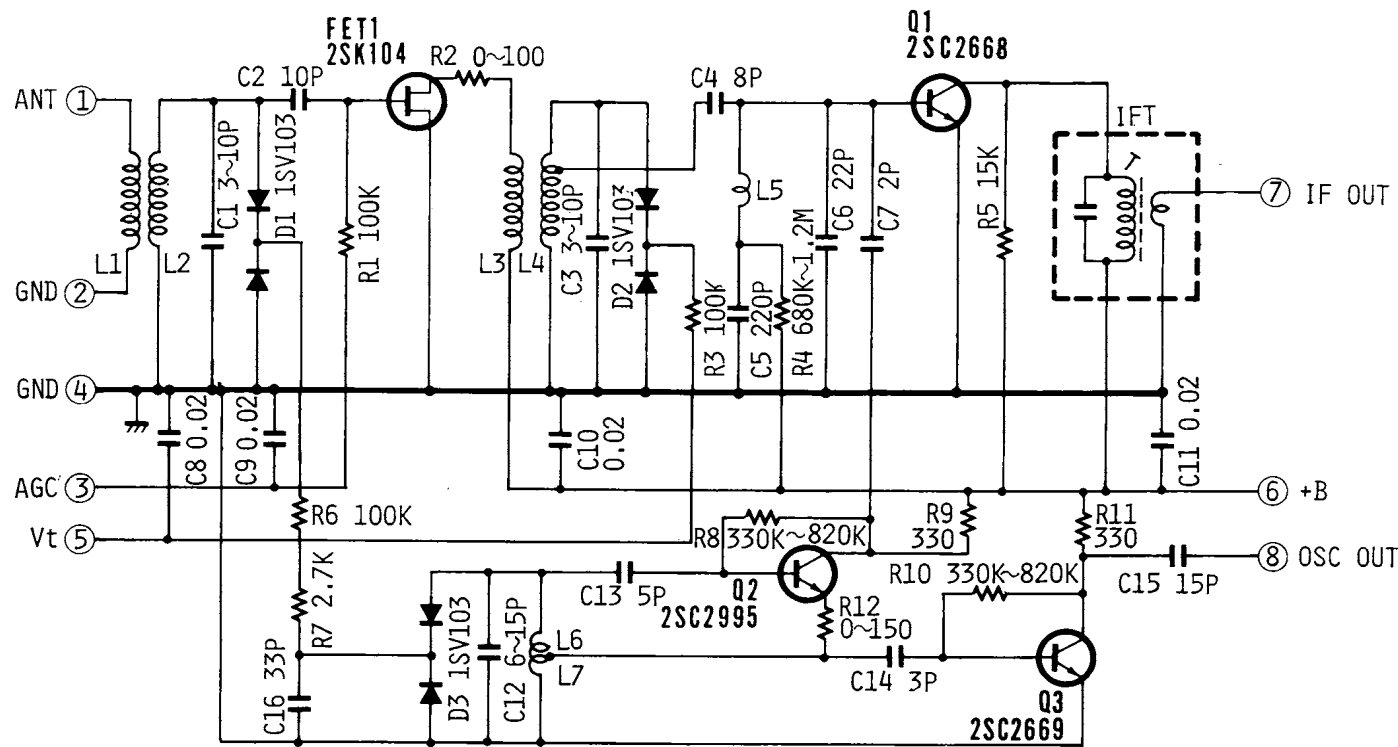

REPLACEMENT PARTS LIST · ERSATZTEILISTE · TABLEAU DES PIECE

o marked parts used for only FT-2, * marked parts used for only FT-2L

SYMBOL No.	PART No.	DESCRIPTION	SYMBOL No.	PART No.	DESCRIPTION
CAPACITORS					
C101	0275015	Mylar, film	C308	1274221	Mylar, film
o C102	0252811	Electrolytic	(except U.S.A. & Canada)		0.0011μF ±5% 50V
o C103	0230026	Cylindrical ceramic	o C309	1274212	Mylar, film
(for W. Germany & Italy)		39pF ±5% 50V	(for U.S.A. & Canada)		0.0015μF ±5% 50V
(for W. Germany and Italy)			C309	1274221	Mylar, film
o C104	0230026	Cylindrical ceramic	(except U.S.A. & Canada)		0.0011μF ±5% 50V
(for W. Germany & Italy)		39pF ±5% 50V	C310	0252521	Electrolytic
C105	0240108	Cylindrical ceramic			10μF 16V
C106	0240108	Cylindrical ceramic	C311	0252521	Electrolytic
		0.022μF ±30% 16V			10μF 16V
o C106	0244173	Ceramic, discal	o C312	0240005	Cylindrical ceramic
		0.022μF +80/-20% 50V	(for W. Germany & Italy)		270pF ±10% 50V
C151	0244185	Ceramic, discal	o C313	0240009	Cylindrical ceramic
C152	0240108	Cylindrical ceramic	(for W. Germany and Italy)		560pF ±10% 50V
C153	0279326	Polypropylene	C314	0252815	Electrolytic
		510pF ±2% 100V			4.7μF 50V
* C154	0230064	Cylindrical ceramic	C315	0252815	Electrolytic
		12 pF ±5% 50V			4.7μF 50V
o C154	0230066	Cylindrical ceramic	* C316	0274012	Mylar, film
		15pF ±5% 50V	(for France & Sweden)		0.0015μF ±10% 50V
* C155	0230072	Cylindrical ceramic	o C316	1274212	Mylar, film
		27pF ±5% 50V	(for Australia, Sweden, Asia & Latin American countries, etc.)		0.0015μF ±5% 50V
* C156	0244185	Ceramic, discal	o C316	1274214	Mylar, film
		0.047μF +80/-20% 50V	(for U.S.A., Canada, W. Germany & Italy)		0.0033μF ±5% 50V
* C157	0240108	Cylindrical ceramic	o C317	0274012	Mylar, film
		0.022μF ±30% 16V	(for France & Sweden)		0.0015μF ±10% 50V
* C158	0228321	Styrol	o C317	1274212	Mylar, film
		270pF ±5% 50V	(for Australia, Sweden, Asia & Latin American countries, etc.)		0.0015μF ±5% 50V
* C159	0246465	Ceramic, discal	o C317	1274214	Mylar, film
		110pF ±5% 50V	(for U.S.A., Canada, W. Germany & Italy)		0.0033μF ±5% 50V
* C160	0240108	Cylindrical ceramic	* C317	0274012	Mylar, film
		0.022μF ±30% 16V	(for France & Sweden)		0.0015μF ±10% 50V
C161	0240108	Cylindrical ceramic	o C317	1274212	Mylar, film
		0.022μF ±30% 16V	(for Australia, Sweden, Asia & Latin American countries, etc.)		0.0015μF ±5% 50V
* C162	0252811	Electrolytic	o C317	1274214	Mylar, film
		1μF 50V	(for U.S.A., Canada, W. Germany & Italy)		0.0033μF ±5% 50V
C201	0244171	Ceramic, discal	C320	0252531	Electrolytic
C202	0244171	Ceramic, discal			100μF 16V
C203	0240106	Cylindrical ceramic	C501	0259891	
		0.01μF +80/-20% 50V	C502	0252242	Electrolytic
C205	0240108	Cylindrical ceramic			2200μF 6.3V
C251	0240108	Cylindrical ceramic	C503	0240108	Cylindrical ceramic
		0.022μF ±30% 16V			0.022μF ±30% 16V
C252	0252811	Electrolytic	C504	0230071	Cylindrical ceramic
		1μF 50V			24pF ±5% 50V
C253	0244173	Ceramic, discal	C505	0230071	Cylindrical ceramic
		0.022μF +80/-20% 50V			24pF ±5% 50V
C254	0252521	Electrolytic	C506	0252880	Electrolytic
		10μF 16V			4.7μF 50V
C255	0240108	Cylindrical ceramic	C507	0240102	Cylindrical ceramic
		0.022μF ±30% 16V			0.0022μF ±30% 50V
C256	0240108	Cylindrical ceramic	C508	0252531	Electrolytic
		0.022μF ±30% 16V			100μF 16V
* C258	0275032	Mylar, film	* C509	0275016	Mylar, film
		0.018μF ±10% 50V			0.068μF ±10% 50V
o C258	0275033	Mylar, film	* C510	0252877	Electrolytic
		0.027μF ±10% 50V			1μF 50V
C259	0252521	Electrolytic	* C511	0252802	Electrolytic
		10μF 16V			0.22μF 50V
C260	0240108	Cylindrical ceramic	C512	0240106	Cylindrical ceramic
		0.022μF ±30% 16V			0.01μF ±30% 25V
C261	0240108	Cylindrical ceramic	C513	0244173	Ceramic, discal
		0.022μF ±30% 16V			0.022μF +80/-20% 50V
C262	0252522	Electrolytic	C514	0252231	Electrolytic
		22μF 16V			100μF 6.3V
C263	0252231	Electrolytic	C515	0252231	Electrolytic
		100μF 6.3V			100μF 6.3V
C264	0246456	Ceramic, discal	C516	0240108	Cylindrical ceramic
		47pF ±5% 50V			0.022μF ±30% 16V
C265	0230016	Cylindrical ceramic	C301	0246470	Ceramic, discal
		15pF ±5% 50V			270pF ±5% 50V
C266	0252521	Electrolytic	C302	0252812	Electrolytic
		10μF 16V			2.2μF 50V
C267	0252803	Electrolytic	C303	0252811	Electrolytic
		0.33μF 50V			1μF 50V
C304	0252802	Electrolytic	C304	0252802	Electrolytic
		0.22μF 50V			0.22μF 50V
C305	0244185	Ceramic, discal	C305	0244185	Ceramic, discal
		0.047μF +80/-20% 50V			0.047μF +80/-20% 50V
C306	0252525	Electrolytic	C306	0252525	Electrolytic
		47μF 16V			47μF 16V
* C307	0230036	Cylindrical ceramic	C801	0244171	Ceramic, discal
		100pF ±5% 50V			0.01μF +80/-20% 50V
o C308	1274212	Mylar, film	C802	0252735	Electrolytic
(for U.S.A. & Canada)		0.0015μF ±5% 50V			470μF 35V
			C803	0252531	Electrolytic
					100μF 16V
			C804	0252531	Electrolytic
					100μF 16V
			C805	0252825	Electrolytic
					47μF 50V
			C806	0244171	Ceramic, discal
					0.01μF +80/-20% 50V
			C807	0252825	Electrolytic
					47μF 50V
			C808	0252815	Electrolytic
					4.7μF 50V
			C809	0252811	Electrolytic
					1μF 50V

BLOCK DIAGRAM · BLOCK SCHEMA · SCHEMA

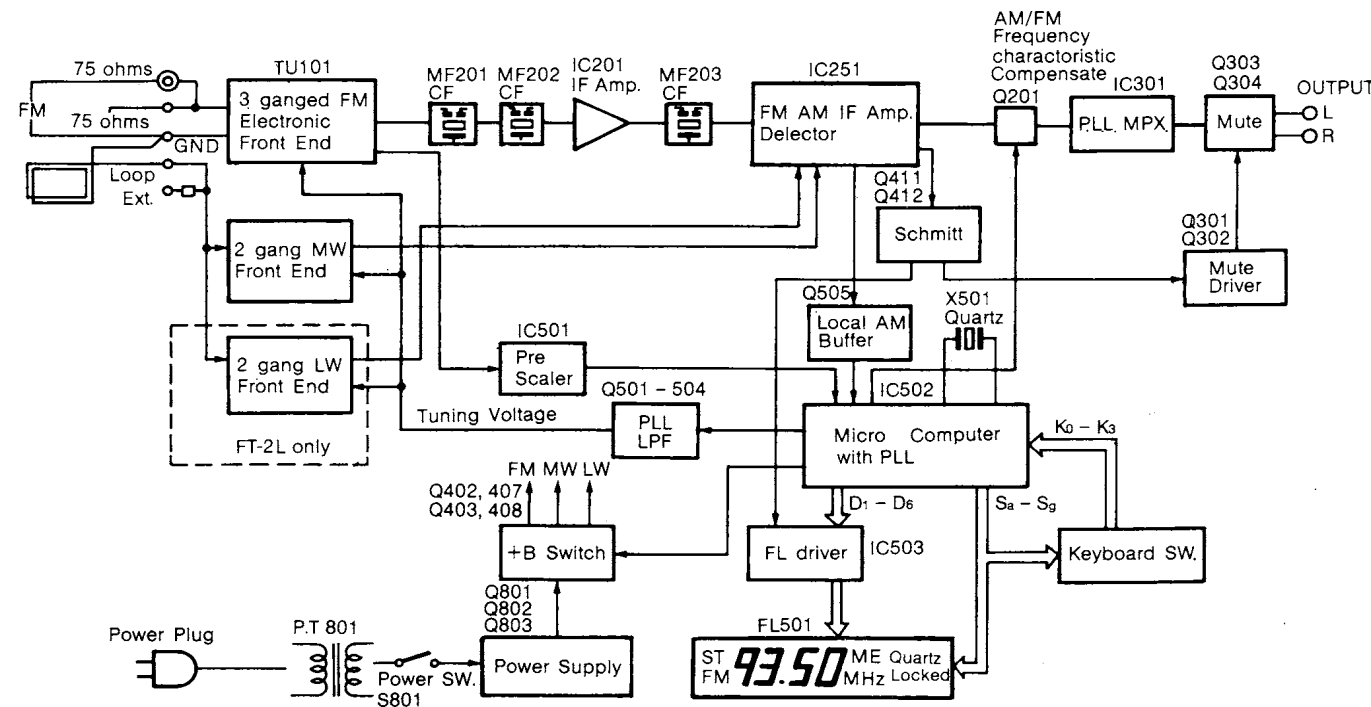

o marked parts used for only FT-2, * marked parts used for only FT-2L

SYMBOL NO.	PART No.	DESCRIPTION			SYMBOL No.	PART No.	DESCRIPTION			
RESISTORS										
R101	0139611	Carbon film	2.7kΩ	±5%		R310	0129647	Carbon film	47kΩ ±5%	SRD1/4P
o R102	0129701	Carbon film	1000kΩ	±5%	SRD1/4P	R311	0129647	Carbon film	47kΩ ±5%	SRD1/4P
		(for W. Germany & Italy)				* R312	0129621	Carbon film	6.8kΩ ±5%	SRD1/4P
o R103	0129611	Carbon film	2.7kΩ	±5%	SRD1/4P	o R312	0129633	Carbon film	12kΩ ±5%	SRD1/4P
		(for W. Germany & Italy)						(except U.S.A. & Canada)		
o R104	0129661	Carbon film	100kΩ	±5%	SRD1/4P	o R312	0129637	Carbon film	18kΩ ±5%	SRD1/4P
		(for W. Germany & Italy)						(for U.S.A. & Canada)		
R106	0123619	Carbon film	68Ω	±5%	SRD1/4P	* R313	0129621	Carbon film	6.8kΩ ±5%	SRD1/4P
R151	0134373	Composition	1kΩ	±10%	RC1/2GF	o R313	0129633	Carbon film	12kΩ ±5%	SRD1/4P
R152	0129631	Carbon film	10kΩ	±5%	SRD1/4P			(except U.S.A. & Canada)		
R153	0129631	Carbon film	10kΩ	±5%	SRD1/4P	o R313	0129637	Carbon film	18kΩ ±5%	SRD1/4P
R154	0129669	Carbon film	220kΩ	±5%	SRD1/4P			(for U.S.A. & Canada)		
* R155	0129631	Carbon film	10kΩ	±5%	SRD1/4P	o R314	0129607	Carbon film	1.8kΩ ±5%	SRD1/4P
* R156	0129631	Carbon film	10kΩ	±5%	SRD1/4P			(for W. Germany & Italy)		
* R157	0129669	Carbon film	220kΩ	±5%	SRD1/4P	* R315	0129609	Carbon film	2.2kΩ ±5%	SRD1/4P
R158	0129579	Carbon film	560Ω	±5%	SRD1/4P	o R315	0129621	Carbon film	6.8kΩ ±5%	SRD1/4P
* R159	0129631	Carbon film	10kΩ	±5%	SRD1/4P	* R316	0129609	Carbon film	2.2kΩ ±5%	SRD1/4P
* R160	0129661	Carbon film	100kΩ	±5%	SRD1/4P	o R316	0129621	Carbon film	6.8kΩ ±5%	SRD1/4P
* R161	0129661	Carbon film	100kΩ	±5%	SRD1/4P	* R317	0129613	Carbon film	3.3kΩ ±5%	SRD1/4P
* R162	0129617	Carbon film	4.7kΩ	±5%	SRD1/4P	o R317	0129647	Carbon film	47kΩ ±5%	SRD1/4P
R202	0129573	Carbon film	330Ω	±5%	SRD1/4P	* R318	0129613	Carbon film	3.3kΩ ±5%	SRD1/4P
R203	0129601	Carbon film	1kΩ	±5%	SRD1/4P	o R318	0129647	Carbon film	47kΩ ±5%	SRD1/4P
o R204	0129561	Carbon film	100Ω	±5%	SRD1/4P	R319	0129647	Carbon film	47kΩ ±5%	SRD1/4P
		(for U.S.A. & Canada)				R320	0129647	Carbon film	47kΩ ±5%	SRD1/4P
R204	0129581	Carbon film	680Ω	±5%	SRD1/4P	R321	0129609	Carbon film	2.2kΩ ±5%	SRD1/4P
		(except U.S.A. & Canada)				R322	0129635	Carbon film	15kΩ ±5%	SRD1/4P
R251	0129601	Carbon film	1kΩ	±5%	SRD1/4P	R323	0129661	Carbon film	100kΩ ±5%	SRD1/4P
o R252	0129609	Carbon film	2.2kΩ	±5%	SRD1/4P	R324	0129645	Carbon film	39kΩ ±5%	SRD1/4P
		(for U.S.A. & Canada)				R325	0129661	Carbon film	100kΩ ±5%	SRD1/4P
R252	0129617	Carbon film	4.7kΩ	±5%	SRD1/4P	R326	0129647	Carbon film	47kΩ ±5%	SRD1/4P
		(except U.S.A. & Canada)				* R327	0129619	Carbon film	5.6kΩ ±5%	SRD1/4P
* R252	0129617	Carbon film	4.7kΩ	±5%	SRD1/4P	* R328	0129619	Carbon film	5.6kΩ ±5%	SRD1/4P
R253	0129609	Carbon film	2.2kΩ	±5%	SRD1/4P	R329	0129647	Carbon film	47kΩ ±5%	SRD1/4P
R254	0129577	Carbon film	470Ω	±5%	SRD1/4P	R401	0129631	Carbon film	10kΩ ±5%	SRD1/4P
R255	0129661	Carbon film	100kΩ	±5%	SRD1/4P	R402	0129647	Carbon film	47kΩ ±5%	SRD1/4P
R256	0129573	Carbon film	330Ω	±5%	SRD1/4P	R403	0129601	Carbon film	1kΩ ±5%	SRD1/4P
R257	0129601	Carbon film	1kΩ	±5%	SRD1/4P	R405	0129601	Carbon film	1kΩ ±5%	SRD1/4P
R258	0129601	Carbon film	1kΩ	±5%	SRD1/4P	* R407	0129631	Carbon film	10kΩ ±5%	SRD1/4P
R259	0129577	Carbon film	470Ω	±5%	SRD1/4P	* R408	0129631	Carbon film	10kΩ ±5%	SRD1/4P
R260	0129577	Carbon film	470Ω	±5%	SRD1/4P	* R409	0129647	Carbon film	47kΩ ±5%	SRD1/4P
		(except U.S.A. & Canada)				R411	0129601	Carbon film	1kΩ ±5%	SRD1/4P
o R260	0129601	Carbon film	470Ω	±5%	SRD1/4P	R412	0129601	Carbon film	1kΩ ±5%	SRD1/4P
		(for U.S.A. & Canada)				R413	0129631	Carbon film	10kΩ ±5%	SRD1/4P
o R261	0129651	Carbon film	68kΩ	±5%	SRD1/4P	R414	0129631	Carbon film	10kΩ ±5%	SRD1/4P
		(for U.S.A. & Canada)				R415	0129563	Carbon film	120Ω ±5%	SRD1/4P
R301	0129643	Carbon film	33kΩ	±5%	SRD1/4P	R416	0129639	Carbon film	22kΩ ±5%	SRD1/4P
R303	0129601	Carbon film,	1kΩ	±5%	SRD1/4P	R417	0129647	Carbon film	47kΩ ±5%	SRD1/4P
R304	0129641	Carbon film	27kΩ	±5%	SRD1/4P	R418	0129647	Carbon film	47kΩ ±5%	SRD1/4P
R305	0129631	Carbon film	10kΩ	±5%	SRD1/4P	R419	0129631	Carbon film	10kΩ ±5%	SRD1/4P
R306	0123619	Carbon film	68Ω	±5%	SRD1/4P	R421	0129647	Carbon film	47kΩ ±5%	SRD1/4P
R307	0129643	Carbon film	33kΩ	±5%	SRD1/4P	R422	0129661	Carbon film	100kΩ ±5%	SRD1/4P
R308	0129643	Carbon film	33kΩ	±5%	SRD1/4P	R501	0129601	Carbon film	1kΩ ±5%	SRD1/4P
o R309	0129667	Carbon film	180kΩ	±5%	SRD1/4P	R502	0129605	Carbon film	1.5kΩ ±5%	SRD1/4P
		(for U.S.A. & Canada)				R503	0129581	Carbon film	680Ω ±5%	SRD1/4P
R309	0129663	Carbon film	120kΩ	±5%	SRD1/4P	R504	0129609	Carbon film	2.2kΩ ±5%	SRD1/4P
		(except U.S.A., Canada, W. Germany & Italy)				R505	0129621	Carbon film	6.8kΩ ±5%	SRD1/4P
						R506	0129601	Carbon film	1kΩ ±5%	SRD1/4P
						* R507	0129601	Carbon film	1kΩ ±5%	SRD1/4P
						* R508	0129631	Carbon film	10kΩ ±5%	SRD1/4P

HITACHI FT-2, FT-2L

◦ marked parts used for only FT-2, * marked parts used for only FT-2L

SYMBOL No.	PART No.	DESCRIPTION			SYMBOL No.	PART No.	DESCRIPTION
* R509	0129621	Carbon film	6.8kΩ ±5%	SRD1/4P	Q411	2328655	2SC1740LN (S)
* R510	0129621	Carbon film	6.8kΩ ±5%	SRD1/4P	Q412	2328655	2SC1740LN (S)
R511	0129551	Carbon film	68Ω ±5%	SRD1/4P	Q501	2328653	2SC1740LN (E)
R512	0129661	Carbon film	100kΩ ±5%	SRD1/4P	Q502	2328653	2SC1740LN (E)
R513	0129661	Carbon film	100kΩ ±5%	SRD1/4P	* Q503	2328653	2SC1740LN (E)
R514	0129661	Carbon film	100kΩ ±5%	SRD1/4P	* Q504	2328653	2SC1740LN (E)
R515	0129661	Carbon film	100kΩ ±5%	SRD1/4P	Q505	2328655	2SC1740LN (S)
◦ R516	0129661	Carbon film	100kΩ ±5%	SRD1/4P	Q801	2317802	2SD1266 (E)
		(for Australia, Sweden, W. Germany, & Italy etc.)			Q802	2328655	2SC1740LN (S)
* R516	0129661	Carbon film	100kΩ ±5%	SRD1/4P	Q803	2329183	2SA1015 (GR)
R524	0129623	Carbon film	8.2kΩ ±5%	SRD1/4P	DIODES		
R525	0129623	Carbon film	8.2kΩ ±5%	SRD1/4P	◦ D101	2337931	1K60R (for W. Germany & Italy)
R526	0129623	Carbon film	8.2kΩ ±5%	SRD1/4P	◦ D102	2337931	1K60R (for W. Germany & Italy)
		Carbon film	±5%	SRD1/4P	D151	2339921	KV1234Z (2)
R528	0129565	Carbon film	150Ω ±5%	SRD1/4P	* D152	2339921	KV1236Z (2)
R529	0129619	Carbon film	5.6kΩ ±5%	SRD1/4P	* D153	2337601	1S2473
◦ R531	0129661	Carbon film	100kΩ ±5%	SRD1/4P	* D154	2337601	1S2473
R532	0129619	Carbon film	5.6kΩ ±5%	SRD1/4P	* D155	2337601	1S2473
R536	0129619	Carbon film	5.6kΩ ±5%	SRD1/4P	* D156	2337601	1S2473
R537	0129601	Carbon film	1kΩ ±5%	SRD1/4P	D157	2337601	1S2473
R538	0129609	Carbon film	2.2kΩ ±5%	SRD1/4P	* D159	2337601	1S2473
R539	0129681	Carbon film	680kΩ ±5%	SRD1/4P	D301	2337601	1S2473
R801	0123607	Carbon film	6.8Ω ±5%	SRD1/4P	D302	2337601	1S2473
R802	0129609	Carbon film	2.2kΩ ±5%	SRD1/4P	D401	2397052	LED SLH - 34 MC (green)
R803	0129601	Carbon film	1kΩ ±5%	SRD1/4P	D402	2397052	LED SLH - 34 MC (green)
R804	0129615	Carbon film	3.9kΩ ±5%	SRD1/4P	D403	2397051	LED SLH - 34 VC (red)
R805	0129615	Carbon film	3.9kΩ ±5%	SRD1/4P	D501	2337601	1S2473
R806	0129569	Carbon film	220Ω ±5%	SRD1/4P	D502	2337601	1S2473
R807	0129615	Carbon film	3.9kΩ ±5%	SRD1/4P	D503	2337601	1S2473 (except U.S.A. & Canada)
◦ R808	0139005	Composition	2700kΩ ±10%	RC1/2GF	◦ D504	2337601	1S2473
		(for U.S.A. & Canada)			D505	2337601	1S2473
					?	?	?
					D510	2337601	1S2473
					D801	2337762	ERB12 - 01R
					?	?	?
					D806	2337762	ERB12 - 01R
					ZD502	2337122	HZ - 6B
					ZD501	2337541	HZ - 7A - 1
					ZD801	2337122	HZ - 6B
					ZD802	2337188	HZ - 24 - 2
ICs & TRANSISTORS							
IC201	2368431	AN278					
IC251	2387321	AN7273					
IC301	2367271	HA1196					
IC401	2387611	BA6251					
IC501	2368741	μPB553AC					
IC502	2369722	μPD1704C - 531					
IC503	2387421	AN6873N					
◦ Q101	2328805	2SK104 (1 - 3) (for W. Germany & Italy)					
* Q151	2328655	2SC1740LN (S)					
* Q152	2328655	2SC1740LN (S)					
Q201	2328655	2SC1740LN (S)					
Q301	2328655	2SC1740LN (S)					
Q302	2329183	2SA1015 (GR)					
Q303	2328655	2SC1740LN (S)					
Q304	2328655	2SC1740LN (S)					
Q402	2329183	2SA1015 (GR)					
Q403	2329183	2SA1015 (GR)					
* Q407	2329183	2SA1015 (GR)					
* Q408	2329183	2SA1015 (GR)					
VARIABLE RESISTORS							
R302	0151333	10kΩ - (B)					
COILS & TRANSFORMERS							
L151	2136503	MW ANT coil					
* L152	2136504	LW ANT coil					
L501	2227354	Choke coil - 2.2μF					
T151	2136493	MW OSC coil					
* T152	2136494	LW OSC coil					

o marked parts used for only FT-2, * marked parts used for only FT-2L

SYMBOL No.	PART No.	DESCRIPTION	SYMBOL No.	PART No.	DESCRIPTION
T251	2155174	FM discri. transformer (P)			
T252	2155175	FM discri. transformer (S)			
T260	2154493	AM IF transformer			
MISCELLANEOUS			for FINAL ASSEMBLY		
CT151	0283127	Trimmer capacitor 20P (red)		3958843	F panel ass'y
* CT152	0283127	Trimmer capacitor 20P (red)	*	3958842	F panel ass'y
o CP301	2136312	Anti - birdy filter (for W. Germany & Italy)	o	3959501	Blind (for U.S.A. & Canada)
* CP302	2136311	Leak filter (for Switzerland & U.K.)	o	3959502	Blind (except U.S.A. & Canada)
* CP303	2136311	Leak filter (for Switzerland & U.K.)		3947541	Nylon rivet
CP501	0241892	CK92DHIH33IML		3297441	Tope knob ass'y
CP502	0189014	RK92YUJ104K7L	o	3297471	Function knob ass'y (FM)
MF201	2135002	Ceramic filter 10.7MS2G (except U.S.A. & Canada)	o	3297472	Function knob ass'y (AM)
o MF202	2154392	Ceramic filter 10.7MS2G (for U.S.A. & Canada)	*	3297541	Function knob ass'y (FM)
MF202	2135002	Ceramic filter 10.7MS2G (except U.S.A. and Canada)	*	3297542	Function knob ass'y (MW)
MF203	2135002	Ceramic filter 10.7MS2G (except U.S.A. & Canada)	*	3297543	Function knob ass'y (LW)
o MF203	2154392	Ceramic filter 10.7MS2G (for U.S.A. & Canada)		3297502	Tact knob (4 × 16)ME
MF203	2135002	Ceramic filter 10.7MS2G		3297503	Tact knob (4 × 16) MO
MF260	2155152	AM ceramic filter SFZ450F	o	3297504	Tact knob (4 × 16) PS
X501	2789161	Crystal oscillator (4.5MHz)		3297511	Tact knob (11 × 11) SH
o PT801	2248302	Power transformer (for U.S.A. & Canada)		3297521	Power button ass'y (for U.S.A. & Canada)
PT801	2248303	Power transformer (240V) (for Australia & U.K.)		3297522	Power button ass'y (except U.S.A. & Canada)
PT801	2248304	Power transformer (W) (except U.S.A., Canada, Australia & U.K.)		4450361	Top cover
S501	2639682	Tact switch		3927411	10 × 21.8 Leg
S502	2639682	Tact switch		4567412	3φ × 8 DT bind screw
* S503	2639682	Tact switch		4567413	3φ × 10 DT bind screw
S504	2638241	Tact switch		4567432	3φ × 8 DT bind screw
S505	2638241	Tact switch		4567463	4φ × 10 DT bind screw
S506	2638241	Tact switch		4567454	3φ × 12 DT bind screw
S507	2639682	Tact switch		4784106	3φ × 10 bind tapping screw
?	?	?		8691308	2.6φ × 8 bind tapping screw
S516	2639682	Tact switch		for REAR PLATE ASSEMBLY	
S517	2638241	Tact switch	*	4450387	Rear plate (T)
o S520	2627531	Slide switch (for W. Germany, Asia & Latin American countries etc.)	o	4450382	Rear plate (T) (for U.S.A.)
S801	2639454	1 key push switch	o	4450383	Rear plate (T) (for Canada)
o S802	2618741	Voltage selector switch 2 (for W. Germany, Asia & Ltain American countries, etc.)	o	4450384	Rear plate (T) (for W. Germany)
F801	2727691	Fuse - T200mA (except U.S.A. & Canada)	o	4450385	Rear plate (T) (for Australia, Sweden & Italy, etc.)
FL501	2789301	Floure scent display tube	o	4450386	Rear plate (T) (for W. Germany, Asia & Latin American countries, etc.)
	2425461	Tuner pack (except W. Germany & Italy, etc.)	o	△ 0043793	Bushing (3P - 4) (for U.S.A. & Canada)
o		Tuner pack	o	△ 3913006	Bushing (except U.S.A. & Canada)
o	2425462	Tuner pack (for W. Germany & Italy)	o	△ 2700121	AC cord (for U.S.A. & Canada)
o	2689373	Antenna terminal (for U.S.A. & Canada)	o	△ 2748754	AC cord (except U.S.A., Canada, Australia & U.K.)
	2689374	Antenna terminal (except U.S.A. & Canada)	*	△ 2749622	AC cord (for Australia)
				△ 2749582	AC cord (for U.K.)
				for ACCESSORIES	
				4023261	AM loop antenna ass'y
				2717893	Patch cord
				2757525	AM antenna 75 ohms (except W. Germany)
			o	△ 2658361	E socket adaptor (for W. Germany, Asia, Ltain American countries, etc.)

FRONT AND REAR PANEL · VORDERE UND HINTERE
BEDIENUNGSTAFEL · PANNEAUX AVANT ET ARRIERE

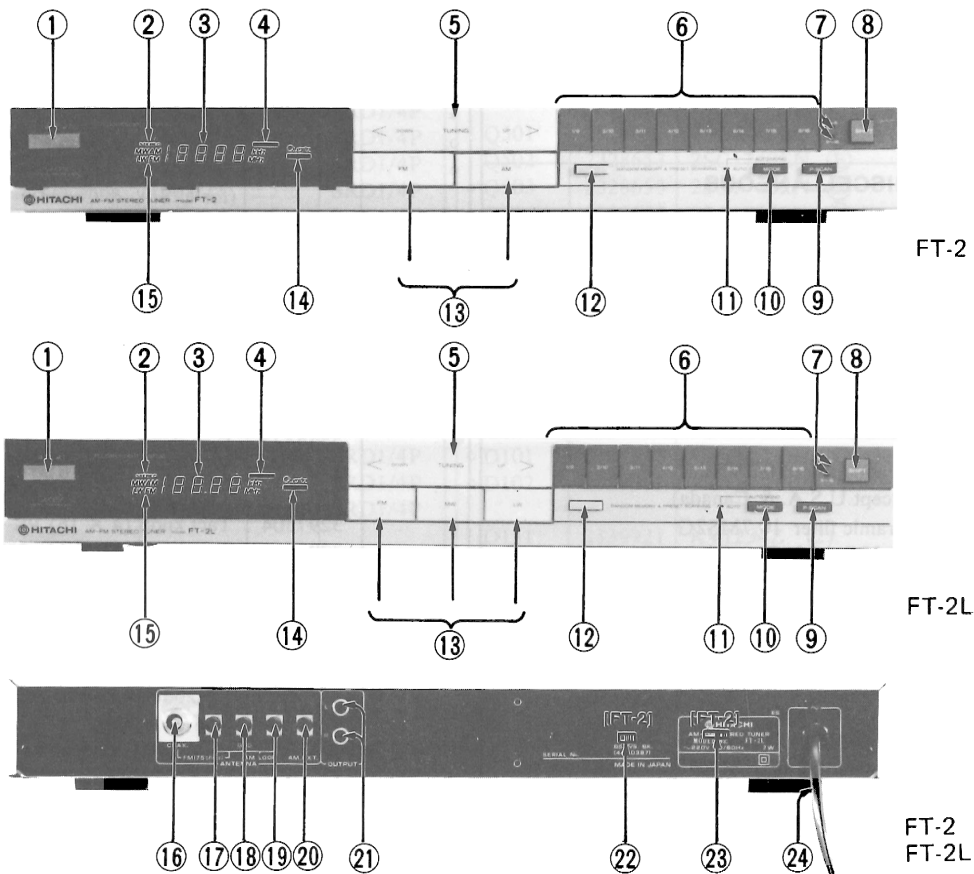

- | | | |
|--|--|---|
| ① POWER switch | ① Netzschalter (POWER) | ① Interrupteur d'alimentation (POWER) |
| ② STEREO indicator | ② Stereo-Anzeige (STEREO) | ② Témoin de mode stéréo (STEREO) |
| ③ Frequency display | ③ Frequenzanzeige | ③ Affichage de fréquence |
| ④ MEMORY indicator | ④ Speicheranzeige (MEMORY) | ④ Témoin d'inscription en mémoire (MEMORY) |
| ⑤ TUNING keys (DOWN, UP) | ⑤ Abstimmtaste (UP/DOWN) | ⑤ Touches d'accord TUNING (bidirectionnel DOWN, UP) |
| ⑥ PRESET keys | ⑥ Vorprogrammierungstasten (PRESET) | ⑥ Touches de préséglage (PRESET) |
| ⑦ Station indicator | ⑦ Stationsanzeigen | ⑦ Indicateurs de station |
| ⑧ SHIFT key | ⑧ Schalttaste (SHIFT) | ⑧ Touche de décalage (SHIFT) |
| ⑨ PRESET SCAN key | ⑨ Festsender Suchlauf-taste | ⑨ Clé de balayage prééglé |
| ⑩ FM mode key | ⑩ UKW-Betriebsartentaste (FM) | ⑩ Touche de mode (FM) |
| ⑪ FM AUTO indicator | ⑪ Kontrollampe für UKW-Suchlaufautomatik (FM AUTO) | ⑪ Témoin de mode (FM AUTO) |
| ⑫ MEMORY write key | ⑫ Speichertaste (MEMORY) | ⑫ Touche d'inscription en memoire (MEMORY) |
| ⑬ FUNCTION switches | ⑬ Funktionsschalter | ⑬ Commutateurs de fonction |
| ⑭ LOCKED indicator | ⑭ Abstimmmanzeige | ⑭ Témoin de verrouillage |
| ⑮ FUNCTION indicators | ⑮ Funktionsanzeigen | ⑮ Témoins de fonction |
| ⑯ FM DIN (75 ohms) antenna terminal | ⑯ UKW-DIN-Antennenanschluß | ⑯ Borne d'antenne FM DIN (75 ohms) |
| ⑰ FM (75 ohms) ANTENNA terminal | ⑰ (FM) (75 Ohm) | ⑰ Borne d'antenne FM (75 ohms) |
| ⑱ GROUND terminal (GND) | ⑱ UKW-Antennenklemme (75 Ohm) | ⑱ (FM ANTENNA) Prise de terre (GND) |
| ⑳ AM LOOP Antenna terminals | ⑳ Erdungsklemme (GND) | ⑳ Bornes d'antenne AM (AM LOOP) |
| ㉑ AM ANTENNA terminal (EXTERNAL) | ㉑ MW-Rahmenantennenbuchse (AM LOOP) | ㉑ Borne d'antenne AM extérieure (EXTERNAL) |
| ㉒ OUTPUT jacks | ㉒ MW Antennenklemme (Externe) | ㉒ Prises de sortie (OUTPUT) |
| ㉓ Channel SPACING selector switch (for Asia & Latin American countries, etc.) (FT-2) | ㉓ Ausgangsbuchsen (OUTPUT) | ㉓ Sélecteur d'espacement de canal (SPACING) (pour l'Asie et l'Amérique latine) (FT-2) |
| ㉔ VOLTAGE SELECTOR (for Asia & Latin American countries, etc.) (FT-2) | ㉔ Frequenzraster-Wahlschalter (SPACING) (für Asien und Lateinamerika) (FT-2) | ㉔ Sélecteur de tension (BOLTAGE SELECTOR) (pour l'Asie et l'Amérique Latine) (FT-2) |
| ㉕ Power supply cord | ㉕ Spannungswähler (VOLTAGE SELECTOR) (für Asien und Lateinamerika) (FT-2) | ㉕ Cordon d'alimentation |
| | ㉕ Netzstromkabel | |

Check that exposed parts are acceptably insulated from the supply circuit before returning the instrument repaired to the customer.

● **Checking method**

Power switch is set to ON.

Next, measure the resistance value between the both poles of attachment cup (Power supply plug) and the exposed parts (Parts such as Ground terminal, Knob, Cover, etc. where the customer is easy to touch.) and check that the resistance value is 500 kohms or more.

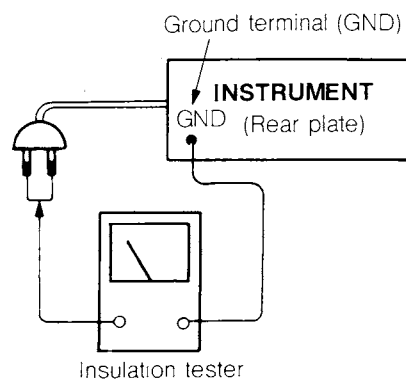



HITACHI SALES CORPORATION OF AMERICA
Eastern Regional Office

1200 Wall Street West, Lyndhurst, New Jersey
07071, U.S.A.
Tel. 201-935-8980

Mid-Western Regional Office

1400 Morse Ave., Elk Grove Village, Ill. 60007, U.S.A.
Tel. 312-593-1550

Southern Regional Office

510 Plaza Drive College Park, Georgia 30349, U.S.A.
Tel. 404-763-0360

Western Regional Office

401 West Artesia Boulevard, Compton, California
90220, U.S.A.
Tel. 213-537-8383

HITACHI SALES CORPORATION OF HAWAII, INC.

3219 Koapaka Street Honolulu, Hawaii 96819, U.S.A.
Tel. 808-836-3621

HITACHI (HSC) CANADA INC.

3300Trans Canada Highway, Pointe Claire, Quebec
H9RU 1B1, Canada
Tel. 514-697-9150

HITACHI SALES EUROPA GmbH

2050 Hamburg 54, Rungedamm 2, West Germany
Tel. 73411-0

HITACHI SALES (U.K.) Ltd.

Hitachi House, Station Road, Hayes, Middlesex UB3
4DR, England
Tel. 01-848-8787 (Service Centre: 01-848-3551)

HITACHI SALES SCANDINAVIA AB

Rissneleden 8, Box 7138, 172-07 Sundbyberg,
Sweden
Tel. 08-98 52 80

HITACHI SALES NORWAY A/S

Oerebekk 1620 Gressvik P.O. Box 46 N-1601
Fredrikstad, Norway
Tel. 032-28255

SUOMEN HITACHI OY

Takojankatsu 5, 15800 Lahti 80, Finland
Tel. Lahti 44 241

HITACHI SALES A/S

Kuldysen 13, DK-2630 Taastrup, Denmark
Tel. 02-999200

HITACHI SALES A.G.

Bahnhofstrasse, 19, 5600 Lenzburg,
Switzerland
Tel. 064-513621

HITACHI FRANCE S.A.

97/115 Rue Charles-Michels 93200
SAINT-DENIS, France
Tel. 201-25-00

HITACHI SALES WARENHANDELS GMBH

A-1180/Wien, Kreuzgasse 27, Austria
Tel. (0222) 439367/8

HITACHI SALES BELGIUM S.A./N.V.

56, Chaussee de Namur, B-1400
Nivelles, Belgium
Tel. (067) 22 7181

HITACHI SALES AUSTRALIA Pty Ltd.

153 Keys Road, Moorabbin, Victoria 3189, Australia
Tel. 555-8722

HITACHI Ltd. TOKYO JAPAN

Head Office: THE HITACHI ATAGO BLDG.
No. 15-12, 2-chome Nishi-Shinbashi
Minato-ku, Tokyo 105, Japan
Tel. Tokyo (03) 502-2111

FT-2
FT-2L

TY No. 374 EGF



HITACHI

SERVICE MANUAL

TY
No. 374-1 EGF
FT-2 (Black)
RECEIVED JUN 2 5 1984

This unit is the same as the model FT-2 [Silver] except that it has the black appearance.

The table below shows the different points from FT-2 [Silver], so use together with the FT-2 [Silver] Service Manual (No.374EGF) issued previously

Gerät ist das gleiche wie das Modell FT-2 [Silbern], ausgenommen davon, daß es schwarz aussieht.

Die nachfolgende Tabelle zeigt die Unterschiede von FT-2 [Silbern], und sie sollte zusammen mit dem früher herausgegebenen Wartungshandbuch für FT-2 [Silbern] (Nr. 374EGF) verwendet werden.

Le appareil est le même que le modèle FT-2 [Argent] à l'exception qu'il a une apparence en noir.

Le tableau ci-dessous indique les points différents du FT-2 [Argent], de ce fait utiliser avec le FT-2 [Argent]. Manuel d'utilisation (N°374EGF) publié préalablement.

REPLACEMENT PARTS LIST · ERSATZTEILLISTE · TABLEAU DES PLÈCE

FT-2 [Black]			FT-2 [Silver]	
SYMBOL No.	PART No.	DESCRIPTION	PART No.	DESCRIPTION
	3958846	F panel ass'y	3958842	F panel ass'y
	3959504	Blind (for U.S.A. & Canada)	3959501	Blind
	3959505	Blind	3959502	Blind
	3297443	Tape button ass'y	3297441	Tape button ass'y
	3297475	Function button ass'y (FM)	3297471	Function button ass'y (FM)
	3297476	Function button ass'y (AM)	3297472	Function button ass'y (AM)
	3297508	Tact knob (4 × 16) ME	3297502	Tact knob (4 × 16) ME
	3297506	Tact knob (4 × 16) MO	3297503	Tact knob (4 × 16) MO
	3297507	Tact knob (4 × 16) PS	3297504	Tact knob (4 × 16) PS
	3297513	Tact knob (11 × 11) SH	3297511	Tact knob (11 × 11) SH
	4415588	Top cover	4450361	Top cover
	4567443	4φ × 10 DT bind screw (for Cover)	4567463	4φ × 10 DT bind screw (for Cover)

SPECIFICATIONS AND PARTS ARE SUBJECT TO CHANGE FOR IMPROVEMENT.

STEREO TUNER

March 1984
TOYOKAWA WORKS

**HITACHI SALES EUROPA GmbH**

Postfach 801060 Rungedamm 2, 2050 Hamburg 80,
West Germany
Tel. 040-734 11-0

HITACHI SALES (U.K.) Ltd.

Hitachi House, Station Road, Hayes, Middlesex UB3
4DR, England
Tel. 01-848-8787

HITACHI SALES SCANDINAVIA AB

Rissneleden 8, Box 7138, 172-07 Sundbyberg, Sweden
Tel. 08-98 52 80

HITACHI SALES NORWAY A/S

Oerebekk 1620, Gressvik, P.O. Box 46, N-1601,
Fredrikstad, Norway
Tel. 032-28255

SUOMEN HITACHI OY

Takojankatsu 5, 15800 Lahti 80, Finland
Tel. Lahti 44 241

HITACHI SALES A/S

Kuldysen 13, DK-2630, Taastrup, Denmark
Tel. 02-999200

HITACHI SALES A.G.

Bahnhofstrasse, 19, 5600 Lenzburg, Switzerland
Tel. 064-513621

HITACHI SALES WARENHANDELS GMBH

A-1180/Wien, Kreuzgasse 27, Austria
Tel. 0222-439367

HITACHI SALES ITALIANA, S.P.A.

Via Cristoforo Colombo 49, Trezzano sul naviglio
(Milano), Italy
Tel. 02-44 59 031

HITACHI SALES BELGIUM S.A.

56 Chaussee de Namur B-1400 Nivelles, Belgium
Tel. (003267) 227181

HITACHI SALES IBERICA, S.A.

Gran Via Carlos Tercero, 101, 1-1, Barcelona-28,
Spain
Tel. 330-8652

HITACHI MAROC (RADIO TV ELECTRO-MANAGER), S.A.

Rue du Havre, Casablanca, Morocco
Tel. 30-73-68, 30-73-57

HITACHI CANARIAS S.A.

Calle San-Francisco No. 19, Santa Cruz de Tenerife
Canary Islands
Tel. 24-64-98

HITACHI SALES (HELLAS) LTD.

110 Syngrou St., Athens, Greece
Tel. 9219082, 9233469

HITACHI SALES (MALAYSIA) SDN. BHD.

17, Jalan 20/16, Petaling Jaya, Selangor, Malaysia
Tel. 762523, 769918, 769836, 762594

HITACHI (SINGAPORE) PTE., LTD.

Room B, C & D, 15th Floor, Yen San Building
268 Orchard Road, Singapore 9, Singapore
Tel. 7378244, 7379826

HITACHI SALES (THAILAND) LTD.

2242-48, New Petchburi Road, Bangkok, Hueykuang
Bangkok, Thailand
Tel. 314-2741

HITACHI ELECTRIC SERVICE CO., (HONG KONG) LTD.

4th Floor Leun Tai Industrial Bldg., 72-76 Kwai Cheong
Road Kwai Chung N.T., Hong Kong
Tel. 240126

HITACHI SALES AUSTRALIA PTY LTD.

153 Keys Road, Moorabbin, Victoria 3189 Australia
Tel. 555-8722

HITACHI SALES CORPORATION OF AMERICA

Eastern Regional Office
1200 Wall Street West, Lyndhurst, New Jersey 07071, U.S.A.
Tel. 201-935-8980

Mid-Western Regional Office

1400 Morse Ave., Elk Grove Village, Ill. 60007, U.S.A.
Tel. 312-593-1550

Southern Regional Office

510 Plaza Drive, College Park, Georgia 30349, U.S.A.
Tel. 404-763-0360

Western Regional Office

401 West Artesia Boulevard, Compton, California 90220 U.S.A.
Tel. 213-537-8383

HITACHI SALES CORPORATION OF HAWAII, INC.

3219 Koapaka Street, Honolulu, Hawaii 96819, U.S.A.
Tel. 808-836-3621

HITACHI (HSC) CANADA INC.

3300 Trans-Canada Highway, Pointe Claire, Quebec,
H9R 1B1, Canada
Tel. 514-697-9150

Hitachi Sales Centroamericans, S.A.

San Rafael de Excazu, (Apartado 10272), San Jose,
Costa Rica
Tel. 28-20-11, 28-00-37

Hitachi Sales Corporation de Panama, S.A.

Nuevo Repato E1 Camen, Calle Ramon Arias y Calle B
Edificio Brasil 100. (Apartado 7657) Panama 5
Panama City, Rep. of Panama
Tel. 61-3100, 61-4305

Hitachi Sales de Chile Cia., Ltda.

Av. Mexico, 0183, Casilla 9793, Correo Central
Santiago, Chile
Tel. 774165

HITACHI-FRANCE S.A.

95-101 Rue Charles Michels,
93200 SAINT-DENIS,
France
Tel. 821 6015

HITACHI LTD. TOKYO JAPAN

Head Office: THE HITACHI ATAGO BLDG.
No. 15-12, 2-Chome Nishi-Shinbashi
Minato-Ku, Tokyo 105, Japan
Tel. Tokyo (03) 502-2111