

SERVICE MANUAL

English
Français
Deutsch

No. 191



SPECIFICATIONS

Specifications and design may be changed without notice since the policy of this company is one of continuous improvement.

FM TUNER SECTION

Circuit system	Microcomputer controlled digital synthesizer system MOS FET RF first stage 4-gang electronic tuner front end Quadrature detection, PLL MPX
Frequency band	88.1 to 107.9 MHz (200 kHz steps) for U.S.A. and Canada 87.50 to 108.00 MHz (50 kHz steps) for Europe, Asia and Latin America
Sensitivity	1.0 μ V (75 ohms IHF and DIN), 10.8 dBf (new IHF 300 ohms)
Image interference ratio	70 dB (98.1 MHz)
IF interference ratio	90 dB (98.1 MHz IHF) 90 dB (98 MHz DIN)
Total harmonic distortion	MONO: 0.1% (at 1 kHz, IHF and DIN) STEREO: 0.2% (at 1 kHz, IHF and DIN)
Signal-to-noise ratio	MONO: 73 dB (IHF) 68 dB (DIN) STEREO: 68 dB (IHF) 64 dB (DIN)
Frequency response	20 Hz to 15 kHz (75 μ s \pm 1 dB) for U.S.A. and Canada 20 Hz to 15 kHz (50 μ s \pm 1 dB) for Europe, Asia and Latin America
Selectivity	70 dB (\pm 400 kHz IHF) 65 dB (\pm 300 kHz DIN)
Stereo separation	48 dB (1 kHz, IHF and DIN)
Capture ratio	1.0 dB (IHF and DIN)
AM suppression ratio	56 dB (IHF and DIN)
Output voltage	550 mV (400 Hz, 75 kHz deviation)
Antenna terminal	300 ohms balanced and 75 ohms unbalanced

AM TUNER SECTION

Circuit system	Microcomputer-controlled digital synthesizer system first stage 2-gang electronic tuner front end
Frequency range	530 to 1,610 kHz (10 kHz steps) for U.S.A. and Canada 531 to 1,602 kHz (9 kHz steps) for Europe, Asia and Latin America
Sensitivity	20 μ V (IHF), 40 μ V (DIN) 300 μ V/m (IHF bar antenna), 500 μ V/m (DIN bar antenna)
Image interference ratio	50 dB (IHF and DIN)
IF interference ratio	34 dB (IHF and DIN)
Selectivity	32 dB (IHF \pm 10 kHz, DIN \pm 9 kHz)
Signal-to-noise ratio	50 dB (IHF and DIN)
Output voltage	150 mV (400 Hz, 30% modulation)

AM/FM STEREO TUNER

September 1979

POWER SUPPLY, OTHERS

Power requirements	AC 120 V 60 Hz for U.S.A. and Canada ~ 110–120 V/220–240 V 50/60 Hz for Asia and Latin America ~ 220–240 V 50 Hz for Europe, U.K. and Australia
Power consumption	12 watts
Dimensions	435 (W) x 105 (H) x 273 (D) mm (17-1/8" x 4-1/8" x 10-3/4")
Weight	4.4 kg
Semiconductors	9 ICs, 49 transistors (4 FETs), 98 diodes (14 LEDs)
Accessory functions	SCAN/FM MUTE switch, MODE switch, SIGNAL indicator, STEREO indicator, Memory write indicator, Station indicator, MEMORY write key, PRESET keys, TUNING keys, Coaxial cable connector (for U.S.A. and Canada) Auxiliary power outlet (for U.S.A. and Canada), DIN antenna socket (for Europe, Asia and Latin America)
Accessories	FM feeder antenna, Connection cord, 3 dry batteries UM-3(G), 75 ohms FM Antenna adaptor (for U.S.A. and Canada)

CARACTERISTIQUES TECHNIQUES

En vertu de la politique d'amélioration continue des produits de la compagnie, ces spécifications et l'aspect extérieur de l'appareil sont présentés sous réserve de modifications sans préavis.

SECTION TUNER FM

Circuit	Système synthétiseur numérique commandé par micro-ordinateur, premier étage RF à MOS FET, détecteur déphaseur, premier étage de tuner électronique 4 cages, circuit PLL MPX
Bande de fréquence	88,1 à 107,9 MHz (par étapes de 200 kHz) pour U.S.A. et Canada 87,50 à 108,00 MHz (par étapes de 50 kHz) pour Europe, Asie et Amérique latine
Sensibilité	1,0 μ V (75 ohm IHF et DIN), 10,8 dBf (nouveau IHF 300 ohms)
Rendement de présélecteur	70 dB (98,1 MHz)
Taux d'interférence FI	90 dB (98,1 MHz IHF) 90 dB (98 MHz DIN)
Distorsion harmonique totale	MONO: 0,1% (à 1 kHz, IHF et DIN) STEREO: 0,2% (à 1 kHz, IHF et DIN)
Rapport signal/bruit	MONO: 73 dB (IHF) 68 dB (DIN) STEREO: 68 dB (IHF) 64 dB (DIN)
Réponse de fréquence	20 Hz à 15 Hz (75 μ s \pm 1 dB) pour U.S.A. et Canada 20 Hz à 15 Hz (50 μ s \pm 1 dB) pour Europe, Asie et Amérique latine
Sélectivité (\pm 300 kHz)	70 dB (\pm 400 kHz IHF) 65 dB (\pm 300 kHz DIN)
Séparation stéréo	48 dB (1 kHz, IHF et DIN)
Taux de capture	1,0 dB (IHF et DIN)
Taux de suppression AM	56 dB (IHF et DIN)
Tension de sortie	550 mV (400 Hz, déviation de 75 kHz)
Bornes d'antenne	300 ohms compensés et 75 ohms non compensés

SECTION TUNER AM

Circuit	Système synthétiseur numérique commandé par micro-ordinateur, premier étage RF à MOS FET, détecteur déphaseur, premier étage de tuner électronique 2 cages, circuit
Gamme de fréquences	530 à 1 610 kHz (par étapes de 10 kHz) pour U.S.A. et Canada 531 à 1 602 kHz (par étapes de 9 kHz) pour Europe, Asie et Amérique latine
Sensibilité	20 μ V (IHF), 40 μ V (DIN) 300 μ V/(Antenne à tige IHF), 500 μ V/m (Antenne à tige DIN)
Rendement de présélecteur	50 dB (IHF et DIN)
Taux d'interférence FI	34 dB (IHF et DIN)
Sélectivité (\pm 300 kHz)	32 dB (IHF \pm 10 kHz, DIN \pm 9 kHz)
Rapport signal/bruit	50 dB (IHF et DIN)
Tension de sortie	150 mV (400 Hz, 300% de modulation)

ALIMENTATION ELECTRIQUE, DIVERS

Courant secteur	AC 120 V 60 Hz pour U.S.A. et Canada ~ 110–120 V/220–240 V 50/60 Hz pour Asie et Amérique latine
Consommation	12 W
Encombrement	435 (L) x 105 (H) x 273 (P) mm
Poids	4,4 kg
Composants	9 CI, 49 transistors (dont 4 FET), 98 diodes (dont 14 LED)
Fonctions accessoires	Commutateur de balayage/assourdissement FM, Commutateur de MODE, Indicateur du SIGNAL, Indicateur STEREO, Indicateur de mise en mémoire, Indicateurs de station, Touche d'inscription en mémoire, Touches de programmation, Touches de syntonisation, Connecteur pour câble coaxial (pour les U.S.A. et le Canada) Prise de sortie CA auxiliaire (pour les U.S.A. et le Canada), Douille d'antenne DIN (pour l'Europe, l'Asie et l'Amérique latine)
Accessoires fournis	Descente d'antenne FM, Cordon de connexion, 3 piles sèches UM-3 (G), Adaptateur pour antenne FM 75 ohms (pour les U.S.A. et le Canada)

TECHNISCHE DATEN

Änderungen der technischen Daten und des Designs bleiben ohne Ankündigung vorbehalten, da eine ständige Verbesserung der Produkte Geschäftspolitik unserer Firma ist.

UKW-TUNER ABSCHNITT

Schaltkreissystem	Mikrocomputer-gesteuertes Digital-Synthesizersystem MOS FET RF als erste Stufe 4-Gang Elektronik-Tuner Eingangsteil Quadraturerfassung, PLL MPX
Frequenzband	88,1 bis 107,9 MHz (200 kHz Raster) für USA und Kanada 87,50 bis 108,00 MHz (50 kHz Raster) für Europa, Asien und Lateinamerika
Nutzempfindlichkeit	1,0 μ V (75 Ohm IHF und DIN) 10,8 dBf (neue IHF 300 Ohm)
Spiegelfrequenzsicherheit	70 dB (98,1 MHz)
ZF-Unterdrückung	90 dB (98,1 MHz IHF) 90 dB (98 MHz DIN)
Gesamtklirrfaktor	MONO: 0,1% (bei 1 kHz, IHF und DIN) STEREO: 0,2% (bei 1 kHz, IHF und DIN)
Rauschabstand	MONO: 73 dB (IHF) 68 dB (DIN) STEREO: 68 dB (IHF) 64 dB (DIN)
Frequenzgang	20 Hz bis 15 kHz (75 μ s \pm 1 dB) für USA und Kanada 20 Hz bis 15 kHz (50 μ s \pm 1 dB) für Europa, Asien und Lateinamerika
Trennschärfe	70 dB (\pm 400 kHz IHF) 65 dB (\pm 300 kHz DIN)
Kanaltrennung	48 dB (1 kHz, IHF und DIN)
Gleichwellenselektion	1,0 dB (IHF und DIN)
MW-Unterdrückungsverhältnis	56 dB (IHF und DIN)
Ausgangsspannung	550 mV (400 Hz, 75 kHz Abweichung)
Antennenklemmen	300 Ohm abgeglichen und 75 Ohm nicht abgeglichen

MW-TUNER ABSCHNITT

Schaltkreissystem	Mikrocomputer-gesteuertes Digital-Synthesizersystem als erste Stufe 2-Gang Elektronik-Tuner Eingangsteil
Frequenzband	530 bis 1 610 kHz (10 kHz Raster) für USA und Kanada 531 bis 1 602 kHz (9 kHz Raster) für Europa, Asien und Lateinamerika
Nutzempfindlichkeit	20 μ V (IHF), 40 μ V (DIN) 300 μ V/m (IHF-Stabantenne), 500 μ V/m (DIN-Stabantenne)
Spiegelfrequenzsicherheit	50 dB (IHF und DIN)
ZF-Unterdrückung	34 dB (IHF und DIN)
Trennschärfe	32 dB (IHF \pm 10 kHz, DIN \pm 9 kHz)
Gesamtklirrfaktor	50 dB (IHF und DIN)
Ausgangsspannung	150 mV (400 Hz, 30% Modulation)

STROMVERSORGUNG, DIV.

Netzspannung	AC 120 V 60 Hz für USA und Kanada ~ 110–120 V/220–240 V 50/60 Hz für Asien und Lateinamerika
Leistungsaufnahme	12 Watt
Abmessungen	435 (B) x 105 (H) x 273 (T) mm
Gewicht	4,4 kg
Halbleiter	9 ICs, 49 Transistoren (4 FET), 98 Dioden (14 LEDs)
Extrafunktionen	Absuch/UKW-Stummabstimmungs-Schalter, Betriebsartenschalter, Feldstärkeanzeige, Stereo-Anzeige, Speicherabrufanzeige, Senderanzeige, Speicherabrufaste, Stationsvorwahltasten, Sendereinstelltasten, Koaxialkabelanschluß (für USA und Kanada Geräte), Zusatznetzausgang (für USA und Kanada Geräte), DIN-Antennenbuchse (für Europa, Asien und Lateinamerika)
Zubehör	UKW-Dipolantenne, Verbindungskabel, 3 Trockenbatterien UM-3 (G), 150Ohm-UKW-Antennenadapter (für USA und Kanada Geräte)

FEATURES • CARACTERISTIQUES • MERKMALE

1. The AM/FM tuning circuits adopt a digital synthesizer system which is based on a crystal oscillator and a PLL (Phase-Locked Loop) IC in order to keep the deviations in the local oscillation frequency down to the accuracy of the crystal oscillator. The adoption of a microcomputer for the tuning control permits automatic tuning from 88.1 *(87.50) MHz to 107.9 *(108.00) MHz in 200* (50) kHz steps for FM reception and manual tuning from 530 *(531) kHz to 1610 *(1602) kHz for AM reception. It also permits the preset tuning of up to seven AM or FM stations. It serves to provide more accurate tuning and enhance operating ease—ideal features now that the number of broadcasting stations is on the rise.
...Frequency range: U.S.A. and Canada (Europe, Asia and Latin America)

	FM section		AM section	
	Frequency range	Step frequency	Frequency range	Step frequency
U.S.A., Canada	88.1 – 107.9 MHz	200 kHz	530 – 1610 kHz	10 kHz
Europe, Asia and Latin America	87.5 – 108.0 MHz	50 kHz	531 – 1602 kHz	9 kHz

2. In place of the usual signal meter, there are signal indicators made up of five light-emitting diodes (LEDs) which display the signal strength. This is a feature you would expect to find in a digital synthesizer tuner, and it tells you the strength of the FM and AM signals at a glance.
3. A dual gate MOS FET is used in the 4-gang electronic tuner and in the RF stage an FET circuit having superb automatic gain control (AGC) characteristics features effective interference rejection.
4. The FM MPX section incorporates a phase-locked loop (PLL) IC to assure stable FM stereo reception and sharp channel separation.
5. A muting circuit employing a reed relay is used for the muting circuit and this is designed to suppress interstation noise which is generated during the tuning operation. It keeps irritating popping noises down to the bare minimum.
6. The programmed stations can be recalled at any time by depressing the corresponding PRESET key, and station indicators above the keys identify which key has been selected.
7. FT-5000 has a convenient DC memory back-up system. This operates on three UM-3 (AA) or R6 dry cells for up to two years, so that in the event of a power failure the memory is not erased.
8. Other attractions include coaxial cable connectors (for U.S.A. and Canada) and a DIN antenna socket (Europe, Asia and Latin America). They all make the tuner easier to operate.

1. Le circuit d'accord AM/FM fait appel à un synthétiseur numérique qui est basé sur un oscillateur à quartz et un CI de PLL (boucle à verrouillage de phase), ceci dans le but de maintenir les déviations présentes au niveau de la fréquence d'oscillation locale à une valeur correspondant à la précision de l'oscillateur à quartz. L'adoption d'un micro-ordinateur pour la commande d'accord permet l'accord automatique de 88,1 *(87,50) MHz à 107,9 *(108,00) MHz par paliers de 200 (50) kHz en réception FM et l'accord manuel de 530 *(531) kHz à 1 610 *(1 602) kHz pour la réception AM. Il permet également la présélection d'accord jusqu'à concurrence de sept stations AM ou FM. Ce micro-ordinateur sert à fournir un accord plus précis et à augmenter la facilité d'utilisation, choses qui sont des particularités idéales à l'heure où le nombre de stations va en s'accroissant.
*.....Gamme de fréquence: U.S.A. et Canada (Europe, Asie et Amérique latine)

	Section FM		Section AM	
	Gamme de fréquence	Fréquence d'avance	Gamme de fréquence	Fréquence d'avance
U.S.A, Canada	88,1 – 107,9 MHz	200 kHz	530 – 1 610 kHz	10 kHz
Europe, Asie et Amérique latine	87,5 – 108,0 MHz	50 Hz	531 – 1 602 kHz	9 kHz

2. A la place du S-mètre habituel, HITACHI a introduit des témoins de signal, réalisés par cinq diodes électroluminescentes (LED); elles affichent l'intensité de réception. Ce dispositif, que l'on s'attend plutôt à trouver sur un tuner synthétiseur numérique, fait voir d'un coup d'œil l'intensité des signaux FM, AM.

3. Un FET MOS à double porte est utilisé dans le tuner électronique à 4 commandes jumelées et, au niveau de l'étage HF, un circuit FET ayant d'excellentes caractéristiques de commande de gain automatique (AGC) pourvoit à l'efficace réjection d'interférences.
4. La section FM MPX inclut un CI de PLL (boucle de verrouillage de phase) de manière à assurer une réception stéréo FM stable ainsi qu'une très bonne séparation de voies.
5. Pour la sourdine, on a utilisé un circuit employant un relais à lames; sa fonction est de supprimer le bruit entre les stations pendant la syntonisation et, de fait, il maintient à un niveau minimum tout bruit soudain et irritant.
6. Une station programmée peut être rappelée à n'importe quel moment en appuyant sur la touche de présélection correspondante et l'indicateur de station situé au-dessus des touches identifie la station choisie.
7. Le FT-500 est muni d'un très pratique système de maintien de mémoire à CC. Ce circuit fonctionne sur trois piles sèches UM-3 (AA) ou R6 pendant une période allant jusqu'à deux ans, de manière à ce qu'en cas de panne d'alimentation, la mémoire ne soit pas effacée.
8. Les autres particularités intéressantes comprennent les connecteurs pour câble coaxial (pour les U.S.A et le Canada et la douille pour fiche DIN (pour l'Europe, l'Asie et l'Amérique latine). Toutes ces particularités rendent le tuner encore plus simple à utiliser.

1. Die MW/UKW-Abstimmkreise verwenden ein Digitalsynthesizersystem, das auf einem Quarz-Oszillator und auf einer phasenstarrten Schleifen-IC (PLL-IC) basiert, um die Abweichungen in der lokalen Oszillatorfrequenz auf die Genauigkeit des Quarzoszillators zu bringen. Die Einführung eines Mikrocomputers für den Abstimmkreis erlaubt automatisches Abstimmen von 88,1* (87,50) MHz bis 107,9* (108,00) MHz in 200* (50)-kHz-Stufen bei UKW-Empfang, und Handabstimmung von 530* (531) kHz bis 1 610* (1 602) kHz bei MW-Empfang. Ebenso ist eine Voreinstellabstimmung von bis zu 7 MW- oder UKW-Stationen möglich. Darüberhinaus wird eine verbesserte Trennschärfe und erweiterter Bedienungskomfort geliefert — ideale Vorteile bei einem immer dichter werdenden Netz von Sendern.

* . . . Frequenzbereich: USA und Kanada* (Europa, Asien und Lateinamerika)

	UKW-Teil		MW-Teil	
	Frequenzbereich	Frequenzraster	Frequenzbereich	Frequenzraster
USA, Kanada	88,1 – 107,9 MHz	200 kHz	530 – 1 610 kHz	10 kHz
Europa, Asien und Lateinamerika	87,5 – 108,0 MHz	50 kHz	531 – 1 602 kHz	9 kHz

2. Anstelle eines gewöhnlichen Feldstärkeinstrumentes sind fünf lichtemittierende Dioden (LEDs) eingebaut, von denen die Signalstärke abgelesen werden kann. Eine solche Ausrüstung kann man natürlich in einem Digital-Synthesizer-Tuner erwarten; die Feldstärke der UKW/MW-Signale ist mit einem Blick festzustellen.
3. Ein Dual-Gate-MOS-FET (Halbleiter-Feldtransistor) ist im 4-Gang-Elektronik-Tuner eingesetzt, und in der Hochfrequenzstufe schafft eine FET-Schaltung mit hervorragenden automatischen Verstärkungsregelungen (AGC)-Charakteristiken effektive Interferenzunterdrückung.
4. Der UKW-MPX-Teil enthält eine phasenstarre Schleifen-IC (PLL-IC) zur Sicherung eines stabilen UKW-Empfanges und klarer Kanaltrennung.
5. Eine Stummabstimmung mit einem Reed-Relais wird für den Muting-Schaltkreis verwendet, wodurch Zwischenstationsrauschen unterdrückt wird, das beim Abstimmen entsteht. Unangenehme Popgeräusche werden auf ein unvermeidbares Minimum verringert.
6. Die programmierten Sender können jederzeit durch Druck auf die entsprechenden Stationsvorwahltasten abgerufen werden, und Senderanzeiger über den Tasten zeigen die gewählte Taste an.
7. FT-5000 hat ein nützliches Gleichstrom-Speicherstützsystem. Dieses wird von 3 UM-3 (AA)- oder R6-Trockenbatterien unterhalten bis zu 2 Jahren, so daß im Falle eines Stromausfalls der Speicher nicht gelöscht wird.
8. Weitere Vorzüge sind Koaxialkabelanschlüsse (für USA und Kanada) und eine DIN-Antennensteckdose (Europa, Asien und Lateinamerika). Dies alles trägt zur vereinfachten Bedienung des Tuners bei.

DISASSEMBLY AND REPLACEMENT • DEMONTAGE ET REMONTAGE • ZERLEGUNG UND AUSTAUSCH

- Removing the cover, escutcheon and bottom plate
- Déposer le couvercle, le cache-entrée et la plaque inférieure
- Ausbau der Abdeckung, der Schildanbringung und der Bodenplatte

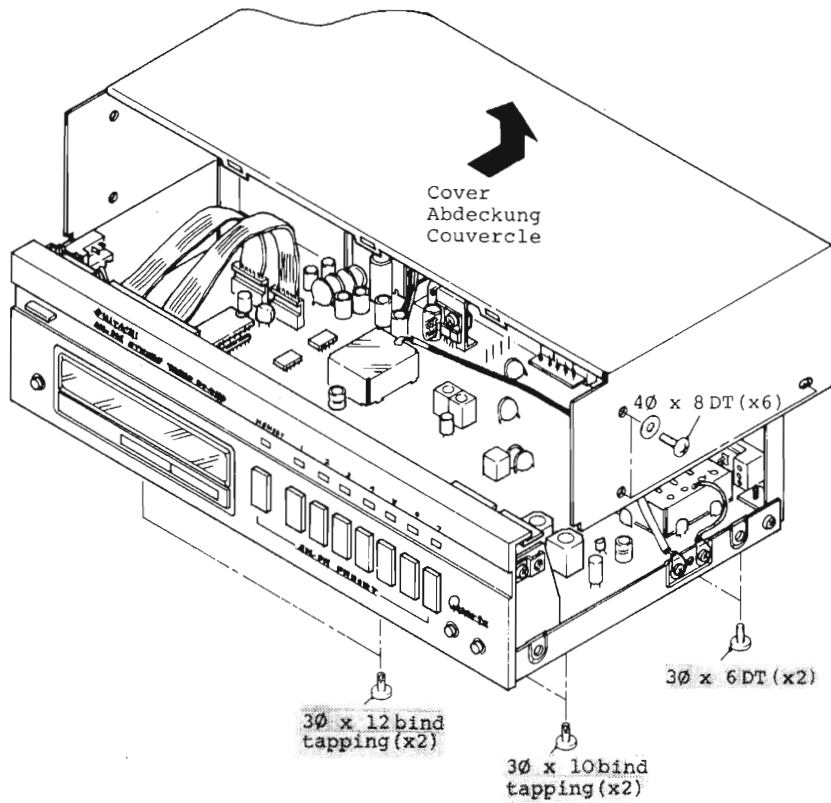

Fig. 1
Abb. 1

- Removing the printed wiring boards
- Déposer des plaquettes à circuit imprimé
- Ausbau der Leiterplatten

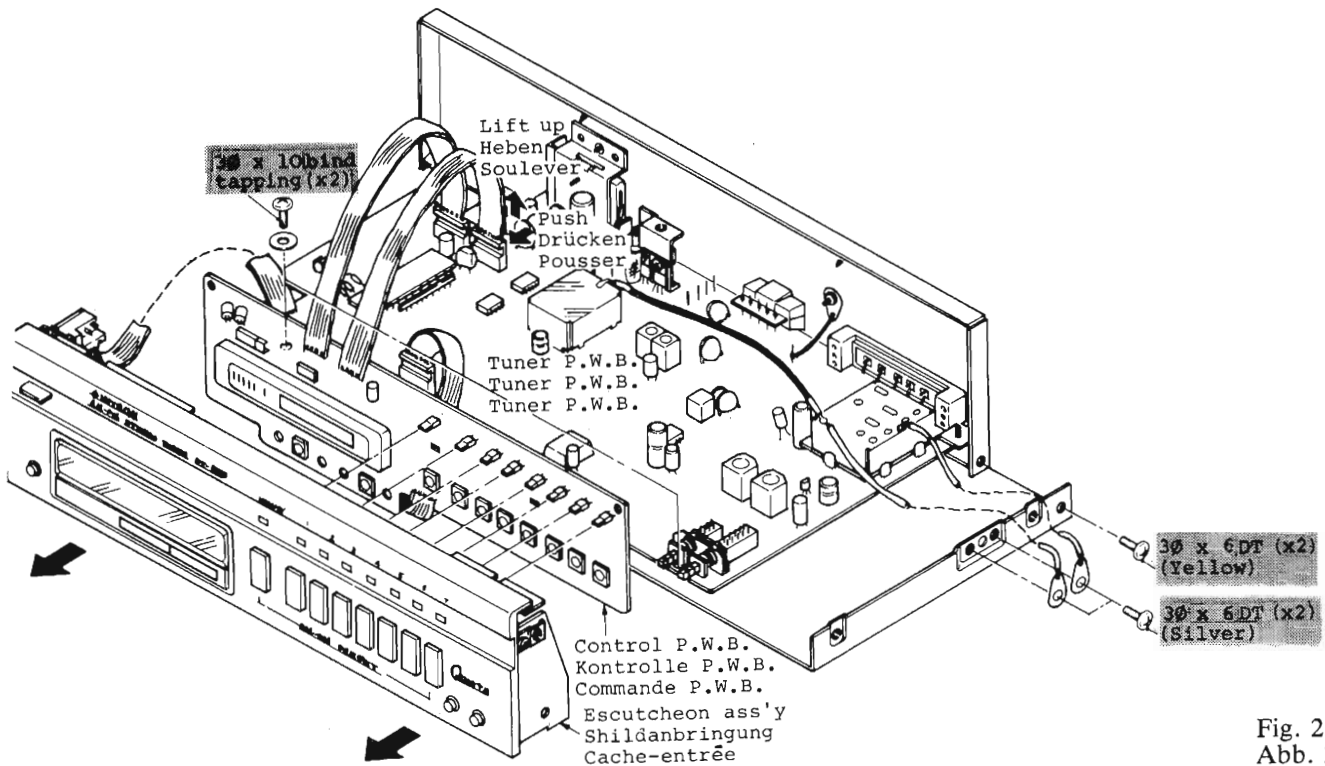

Fig. 2
Abb. 2

3	Covering Guipage Abstimmung	—	F.OUT Tuner pack	—	—	L O	98.2 MHz (Note 4) (Anm. 4)	
				—	—	TCO	118.70 MHz (Note 5) (Anm. 5)	
							Repeat 4	
4	Tracking Alignement Nachführung	ANT. Terminal (300 ohms)	Output Terminal	90.1 or 90.00 MHz	90.1 or 90.00 MHz	LA, LR1, LR2	V max. (Note 6) (Anm. 6)	
				106.1 or 106.00 MHz	106.1 or 106.00 MHz	TCA, TCR1, TCR2		
5	Discriminator. Discriminateur Diskriminator		R221				Repeat 5	
6	Distortion Distorsion Verzerrung		C203	98.1 or 98.00 MHz	98.1 or 98.00 MHz	T201	(Note 7) (Anm. 7)	
7	Output Sortie Ausgang		1 kHz, 75 kHz (dev.) 60 dB μ (for U.S.A. Canada) 40 kHz (dev.) (except for U.S.A. Canada)					Distortion min. (Note 8) (Anm. 8)
8	Muting level Silencieux Mute Pegel		ANT. Terminal (300 ohms)					
9	Signal IND. Indicateur de signal Signalanzeige	1 kHz, 75 kHz (dev.) 55 dB μ (for U.S.A. Canada) 40 kHz (dev.) (except for U.S.A. Canada)	OUTPUT Dist.	98.1 or 98.00 MHz	98.1 or 98.00 MHz	R215	(Note 9) (Anm. 9)	
10	Mute bandwidth Largeur de bande sourdine Stillabstimmungs- Bandbreite	ANT. Terminal (300 ohms) 1 kHz, 40 kHz (dev.) 20 dB μ		98.1	98.1 \pm 80 kHz detuning	R210	Mute ON by \pm 80 kHz detuning tolerance \pm 10 kHz	
				98.00 MHz (Mute SW. ON)	98.00 MHz \pm 30 kHz detuning		Mute ON by \pm 30 kHz detuning tolerance \pm 5 kHz	
11	76 kHz	ANT. Terminal (300 ohms) 60 dB μ Non Mod.	Tuner P.W.B. 	98.1 or 98.00 MHz	98.1 or 98.00 MHz	R301	76 kHz \pm 0.12 kHz	
12	Separation Séparation Separation	ANT. Terminal (300 ohms) (L + R) 34.5 KHz Dev. (L - R) 34.5 KHz Dev. Pilot 6 kHz Dev. fm = 1 kHz (for U.S.A. and Canada) (75 ohms) (L + R) 20 kHz Dev. (L - R) 20 kHz Dev. Pilot 6 kHz Dev. (except for U.S.A. and Canada)	Output Terminal	98.1 or 98.00 MHz	98.1 or 98.00 MHz	R314	Cross talk MIN. Lch \rightarrow Rch. Rch \rightarrow Lch.	

- (Note 1) Perform adjustment at least 3 minutes after the power has been switched on.
 - (Note 2) Using a sweep generator, apply low-input signals (with a small amount of noise superimposed as in Fig. 4, and adjust the tuner pack's IFT so that the waveforms are brought to their maximum in center marker frequency (10.7 MHz).
 - (Note 3) Adjust the T201 coil and obtain an S-curve. Now adjust the T202 coil and improve the linearity of the S-curve.
- Carry out the adjustments Item 3 and 4 below only when you have touched the interior of the front end by mistake.
- (Note 4) Disconnect the wiring (J4) in tuner PWB (PLL OUT), and apply a 2.82 V DC voltage to pin (11) B2 in the tuner pack PWB, and adjust Lo so that the frequency of LOCAL OUT fed out to pin (7) F.OUT is brought to 98.10 MHz.
 - (Note 5) Disconnect the wiring (J4) in tuner PWB (PLL OUT), and apply a 23.17 V DC voltage to pin (11) B2 in the tuner pack PWB, and adjust TCo so that the frequency of the LOCAL OUT fed out to pin (7) F.OUT is brought to 119.70 MHz.
 - (Note 6) Reduce the output of the FM signal generator as the adjustments advance, and ultimately reduce so that noise is superimposed on the output waveforms (so that the limiter does not work).
 - (Note 7) Connect a DC null meter across R221 and C203 on the tuner PWB and adjust T201 core for a reading of 0 V ± 60 mV.
 - (Note 8) When the distortion adjustment is performed, there will be a slight deviation in the discriminator adjustment performed under 5. Therefore, repeat adjustments 5 and 6 several times and adjust for a reading of 0 V on the DC null meter with the distortion at its minimum.
 - (Note 9) Set the muting switch to ON and adjust for a rise in the output.
 - (Note 10) Adjust R230 on the tuner PWB, so that five signal indicator LEDs light up.

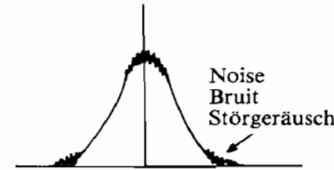

Fig. 4
Abb. 4

- (Note 1) Effectuer le réglage 3 minutes au moins après que l'appareil ait été mis sous tension.
 - (Note 2) Lorsque l'on utilise un générateur de balayage, envoyer des signaux de faible entrée (avec une petite quantité de parasites surimposés, comme indiqué sur la figure 4), et régler le transformateur de fréquence intermédiaire (IFT) de façon que les formes d'onde atteignent leur maximum à la fréquence du point central (10,7 MHz)
 - (Note 3) Régler la bobine T201 de façon à obtenir une courbe en S. Puis régler la bobine T202 de façon à améliorer la linéarité de la courbe en S.
- N'effectuer les réglages des Items 3 et 4 ci-dessous que si vous avez touché l'intérieur de l'extrémité avant par erreur.
- (Note 4) Débrancher le câble (J4) du PWB du tuner (PLL OUT), puis envoyer un courant CC de 2,82 V dans la broche (11) B2 du PWB de l'ensemble tuner et régler Lo de façon que la fréquence de LOCAL OUT envoyée à la sortie de fréquence (F.OUT) de la broche (7) atteigne 98,10 MHz.
 - (Note 5) Débrancher le câble (J4) du PWB du tuner (PLL OUT) et envoyer un courant CC de 23,17 V à la broche (11) B2 du PWB de l'ensemble tuner, et régler le TCo de façon que la fréquence de LOCAL OUT envoyée à la sortie de fréquence (F.OUT) de la broche (7) atteigne 119,70 MHz.
 - (Note 6) A mesure que le réglage progresse, diminuer la sortie du générateur de signaux FM, jusqu'à ce que les parasites soient surimposés sur les formes d'onde de sortie (pour que le limiteur n'entre pas en service).
 - (Note 7) Relier un compteur de zéro CC au PWB du tuner en passant par R221 et C203, puis régler de façon à obtenir 0 V ± 60 mV à l'affichage pour l'âme T201.
 - (Note 8) Lorsque le réglage de la distorsion est effectué, il se produira une légère déviation dans le réglage dans le discriminateur effectué en 5. En conséquence, recommencer plusieurs fois les étapes 5 et 6 de façon à obtenir 0 V sur le compteur CC de zéro avec une distorsion minimum.
 - (Note 9) Mettre l'interrupteur d'atténuation sur ON et régler de façon à augmenter la sortie.
 - (Note 10) Régler R230 du PWB du tuner de façon que les cinq LED indicatrices de signaux s'allument.

- (Anmerk.1) Einstellungen erst nach mehr als 3 Minuten Einschaltzeit vornehmen.
 - (Anmerk.2) Niedrige Eingangssignale (mit kleineren überlagerten Rauscheffekten nach Abb. 4) durch Anwendung eines Oszillators einspeisen und die IFT des Tunerpacks so justieren, daß die Frequenzwellen ihr Maximum in der Mittelbereichsfrequenz (10,7 MHz) erreichen.
 - (Anmerk.3) Durch Justierung der T201-Spule wird eine S-Kurve erzeugt. Anschließend die T202-Spule justieren um die Linearität der S-Kurve zu vervollkommen.
- Die Einstellungen in Artikel 3 und 4 nur vornehmen, wenn das Innere der Stirnseite versehentlich angefaßt wurde.
- (Anmerk.4) Die Schaltung (J4) im Tuner PWB (PLL eingeschaltet) unterbrechen und eine 2,82 V Gleichstromspannung dem Steck-Anschluß (11) B2 im Tunerpack PWB zuführen. Anschließend das "Lo" einstellen, so daß die Frequenz von LOCAL OUT den Steck-Anschluß (7) erreicht. Frequenzausgang (F.OUT) wird auf 98,10 MHz gesteigert.
 - (Anmerk.5) Die Schaltung (J4) im Tuner PWB (PLL ausgeschaltet) unterbrechen und eine 23,17 V Gleichstromspannung dem Steck-Anschluß (11) B2 im Tunerpack PWB zuführen. Anschließend "TCo" so einstellen, daß die Frequenz von LOCAL OUT den Steck-Anschluß (7) erreicht. Frequenzausgang (F.OUT) wird auf 119,70 MHz gesteigert.
 - (Anmerk.6) Den Ausgang des UKW-Meßoszillators entsprechend den Voreinstellungen reduzieren, so daß Rauschen beim kurvenförmigen Ausgang ausgeschlossen wird, wobei der (Amplituden-) Begrenzer nicht betrieben wird.
 - (Anmerk.7) Einen Gleichstrom-Nullzähler durch R221 und C203 des Tuners PWB anschließen und den T201 zur Anzeige von 0 V ± 60 mV einstellen.
 - (Anmerk.8) Nach Durchführung der Regulierung des Klirrfaktors, ergibt sich eine leichte Abweichung der unter 5 durchgeführten differenzierten Einstellung; die Einstellungen 5 und 6 aufgrund dessen mehrmals wiederholen und zur Anzeige von 0 V auf dem Gleichstrom-Nullzähler bei minimaler Verzerrung einstellen.
 - (Anmerk.9) Den Muting-Schalter auf ON (Ein) stellen und zur Anhebung des Ausgangs regulieren.
 - (Anmerk.10) R230 der Tuner PWB einstellen, so daß 5 Signalanzeiger-LED aufleuchten.

AM TUNER ALIGNMENT • REGLAGE DU TUNER AM • ABGLEICH DES AM-TUNERS

Condition Contidions Bedingung Function: AM Modulation: 400 Hz 30%
 Fonction: AM Modulation: 400 Hz 30%
 Funktion: AM Modulation: 400 Hz 30%

Sequence Séquence Reihenfolge	Connection Conexion Anschluß		Setting Montage Setzen		Adjust for Réglage pour Einstellen für	
	Input Entrée Eingang	Output Sortie Ausgang	Tuning Indicateur d'accord Abstimmung	Signal Signal Signal	Adjust Réglage Einstellen	Indication Indication Indikation
1 IF Amp. Amplificateur de fréquence intermédiaire ZF Verstärker	Out Sortie Ausgang 0.1 μ 100 k	In Entrée Eingang Tuner PWB 100K 0.1μ		450 kHz	T152	
2 Covering Guipage Abgleich	Ferrite antenna Antenne en ferrite Ferritantenne	R156 Tuner PWB R155		530 kHz or 531 kHz	T151	
3 Tracking Alignement Vorstufe				600 kHz or 603 kHz 1400 kHz or 1404 kHz	L001 Ferrite antenna Antenne en ferrite Ferritantenne CT151	

Caution

- Adjust black cores of T152 so that the waveform is as shown in Fig. 5. As T152 contains a 450 kHz ceramic filter, sometimes the 450 kHz point will not correspond to that of the waveform. In this case ignore the marker. After adjusting as above, increase the output level of the sweep generator and adjust T152 again so that the top of the waveform A (indicated in Fig. 6) will be flat and wide.
- Connect a DC null meter across R156 and R155 on the tuner PWB and adjust red core of T151 for a reading of 1.8 V. Furthermore, carry out this adjustment for final adjustment of the coil only when you have moved the core by mistake.
- Set the input level to 74 dB in coarse adjustment. Reduce the input level to minimum (50 dB) as adjustment proceeds.

Attention

- Régler les âmes noires de T152 de façon à obtenir une forme d'onde comme indiquée sur la fig. 5. Comme T152 contient un filtre en céramique de 450 kHz, le point de 450 kHz ne correspondra parfois pas à celui de la forme d'onde. Dans ce cas, ne pas s'occuper du marqueur. Après avoir réglé comme indiqué ci-dessus, augmenter le niveau d'entrée du générateur de balayage et régler T152 à nouveau de façon que le sommet de la forme d'onde A (voir Fig. 6) soit aplati et large.
- Relier un compteur de zéro CC au PWB du tuner en passant par R156 et R155 et régler l'âme rouge de T151 de façon à obtenir 1,8 V à l'affichage. N'effectuer le dernier réglage de la bobine par ce réglage que si vous avez bougé l'âme par erreur.
- Faire un réglage approximatif du niveau d'entrée à 74 dB. Réduire le niveau d'entrée jusqu'à un minimum de 50 dB à mesure que l'on effectue le réglage.

Zur Beachtung

- Die schwarzen Cores von T152 so einstellen, daß die Kurvenform der in Abb. 5 dargestellten entspricht. Da T152 einen 450 kHz Keramikfilter enthält, entspricht manchmal der 450kHz-Punkt nicht dem der Kurvenform; dabei einfach die Markierung ignorieren. Nach der zuvor beschriebenen Einstellung den Ausgangspegel des Oszillators erhöhen und T152 abermals einstellen, so daß die Spitze der Kurvenform A (s. Abb. 6) flach und breit wird.
- Einen Gleichstrom-Nullzähler durch R156 und R155 am Tuner PWB verbinden und den roten Core des T151 zur Erfassung von 1,8 V einstellen. Diese Einstellung zur abschließenden Angleichung der Spule nur vornehmen, wenn der Core irrtümlich bewegt wurde.
- Den Eingangspegel auf 74 dB grob einstellen. Auf minimal 50 dB nach Verlauf der Einstellung zurückstellen.

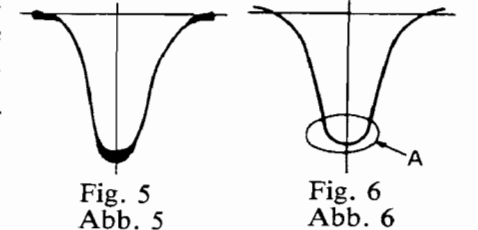
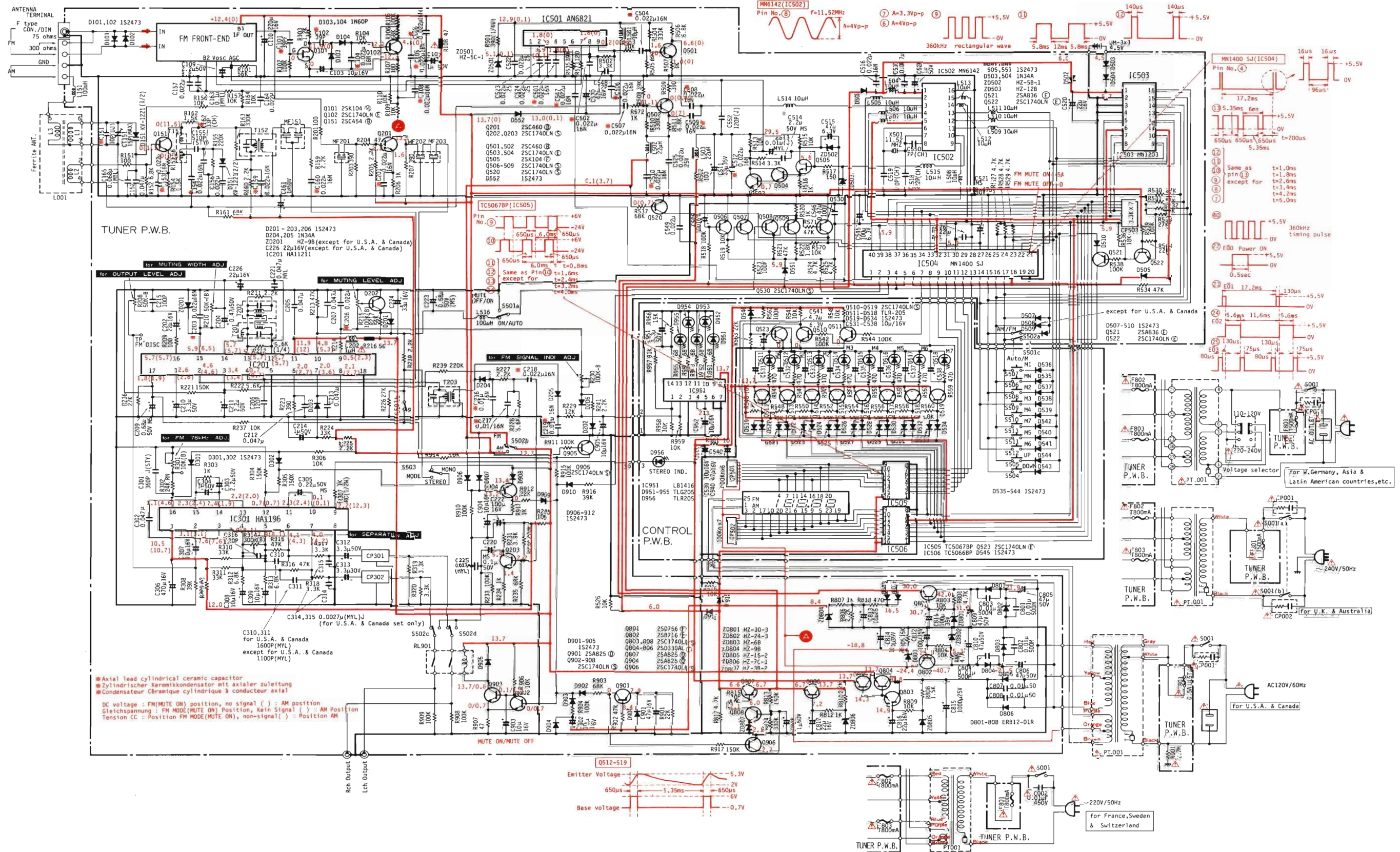

Fig. 5
Abb. 5

Fig. 6
Abb. 6

CIRCUIT DIAGRAM • PLAN DE CIRCUIT • SCHALTPLAN



CAUTION: Fuse resistors are used to improve safety (to protect the circuit). When replacing them with new ones, be sure to use the designated type. Always use the designated fuse without fail.

ATTENTION: Les résistances à fusible sont faites pour améliorer la sécurité de l'appareil (protection de circuit). Pour les remplacer, utiliser le même type. Utiliser toujours le modèle de fusible spécifié pour effectuer le remplacement.

ZUR BEACHTUNG: Schmelzwiderstände sind zur Erhöhung der Sicherheit vorgesehen (zum Schutz der Schaltung). Bei Austausch bitte nur die vorgeschriebene Type benutzen. Vergewissern Sie sich, daß die richtige Type gewählt ist.

PRODUCT SAFETY NOTE: Components marked with a Δ have special characteristics important to safety.

NOTICE DE SECURITE DE FABRICATION: Les composants qui sont accompagnés du symbole Δ possèdent des caractéristiques spéciales.

SICHERHEITSHINWEIS: Die mit Δ gekennzeichneten Komponenten haben wichtige Sicherheitsaufgaben.

PRINTED WIRING BOARD • PLAN DE BASE

Tuner

[■ : +B, ■ : -B, ■ :Earth, ■ :Other]

The circuit symbol (■) means a fuse resistor. When replacing it with new one, refer to the CAUTION on page 11.
 Le symbole de circuit (■) signifie qu'il s'agit d'une résistance à fusible. Consulter les instructions "ATTENTION" de la page 11 pour effectuer son remplacement.
 Das Schaltsymbol (■) steht für Schmelzwiderstand. Beim Austausch bitte Seite 11 ZUR BEACHTUNG nachlesen.

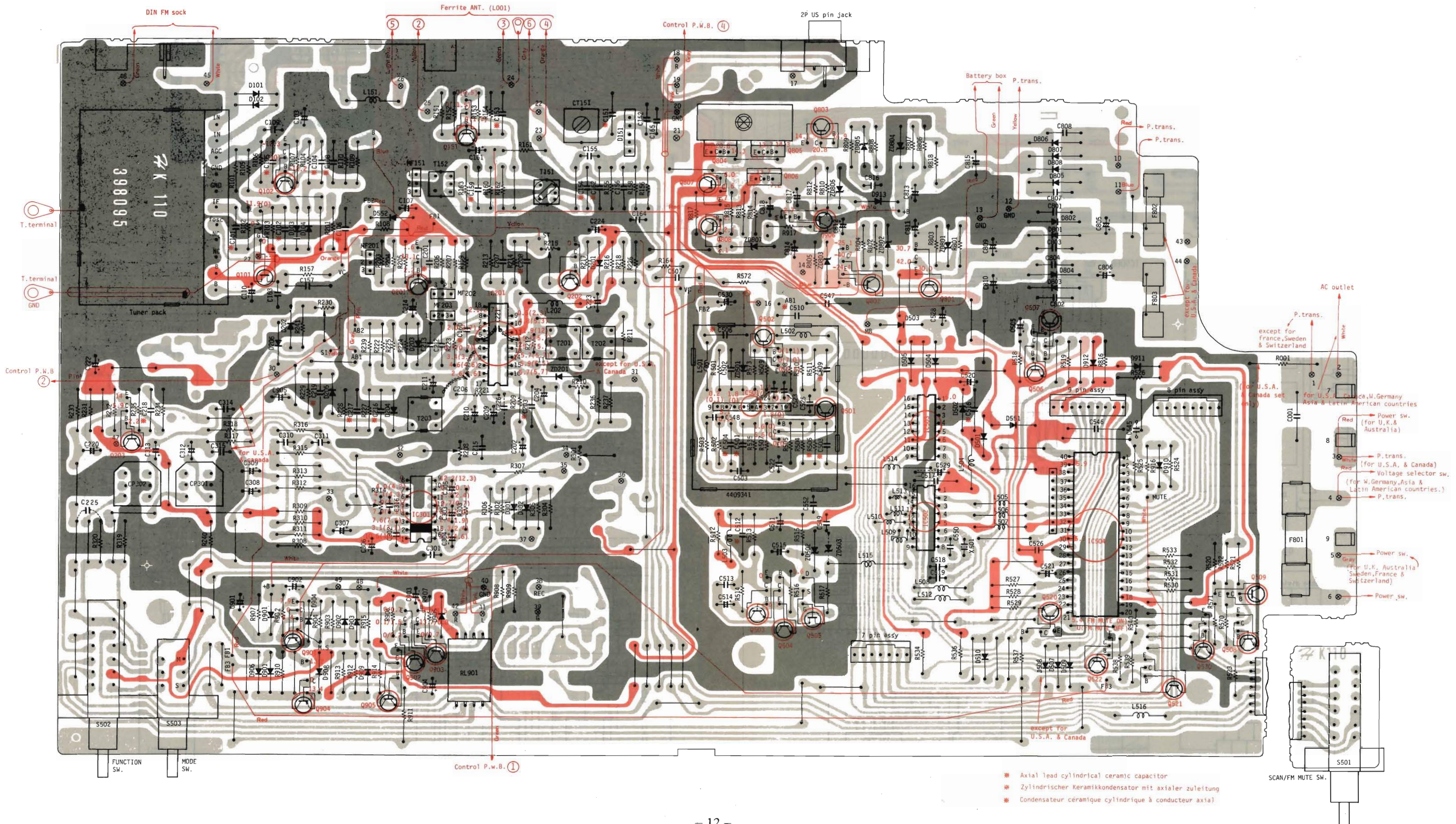

PRINTED WIRING BOARD • PLAN DE BASE • PRINTPLATTEN

Control

[■ : +B ■ : -B, ■ : Earth, ■ : Other]

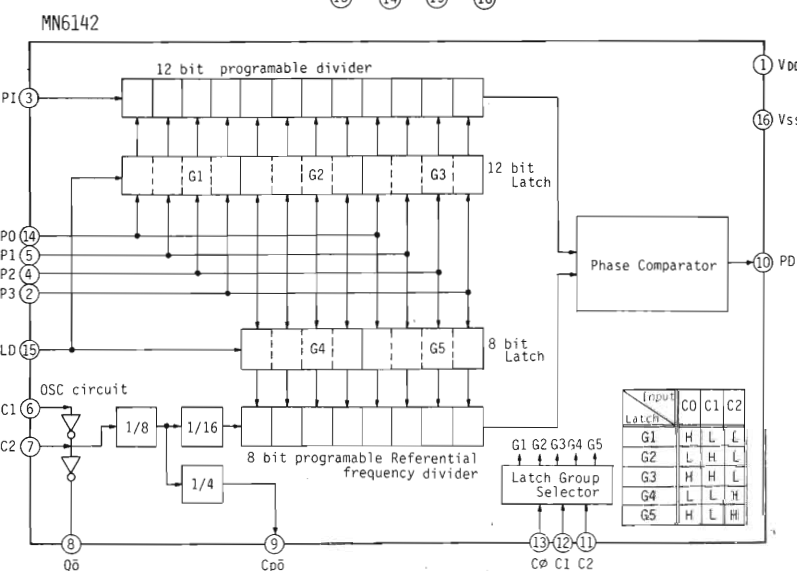
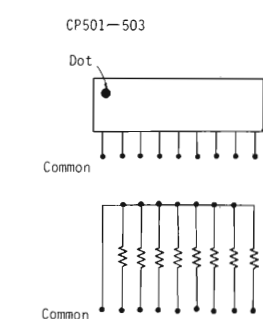
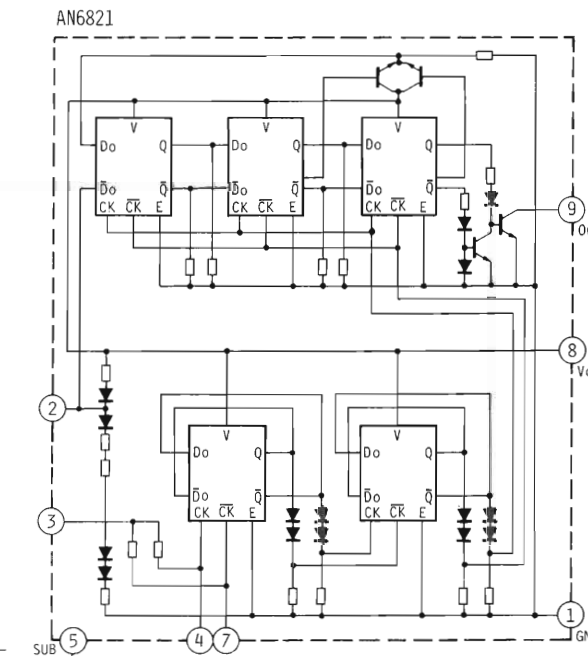
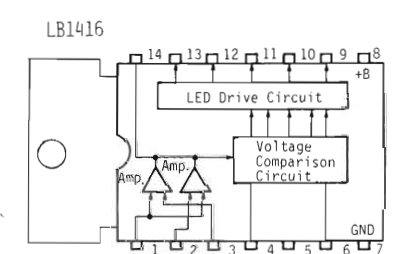
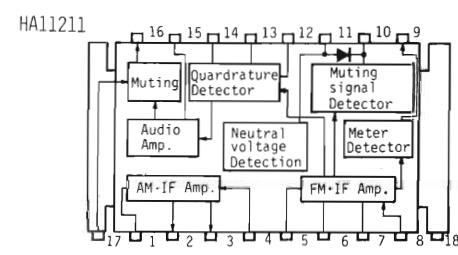
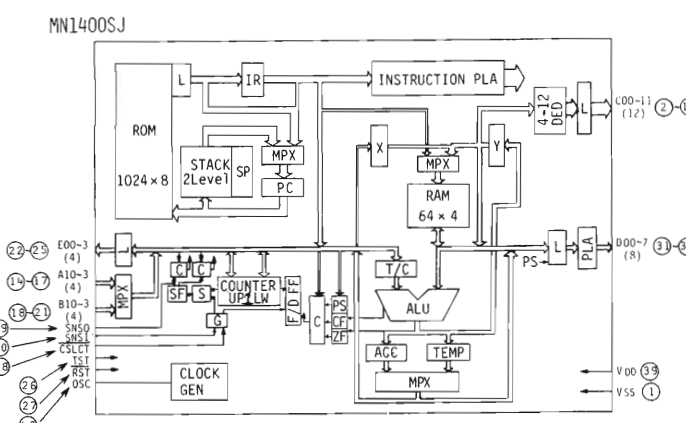
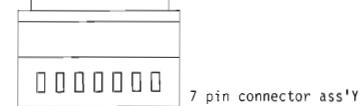
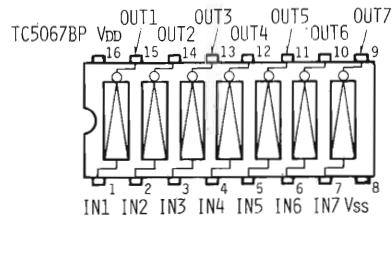
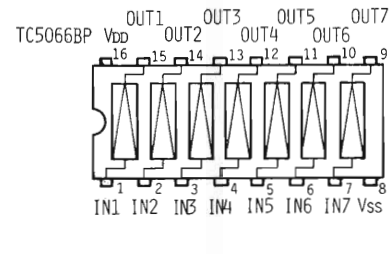
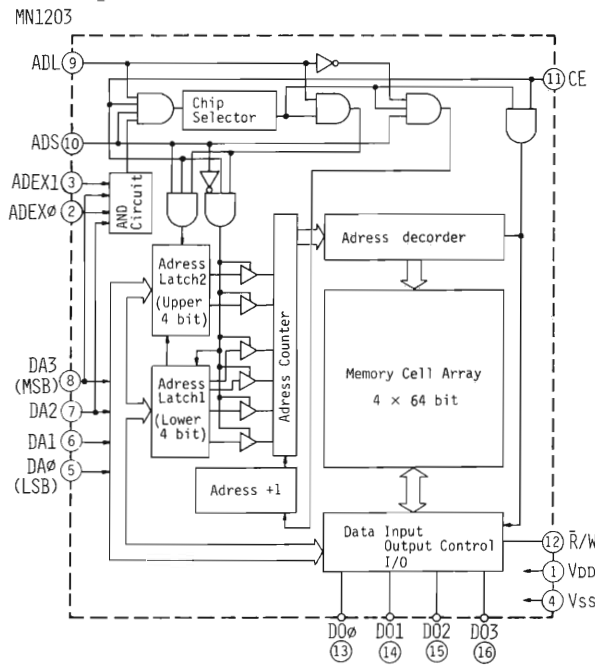
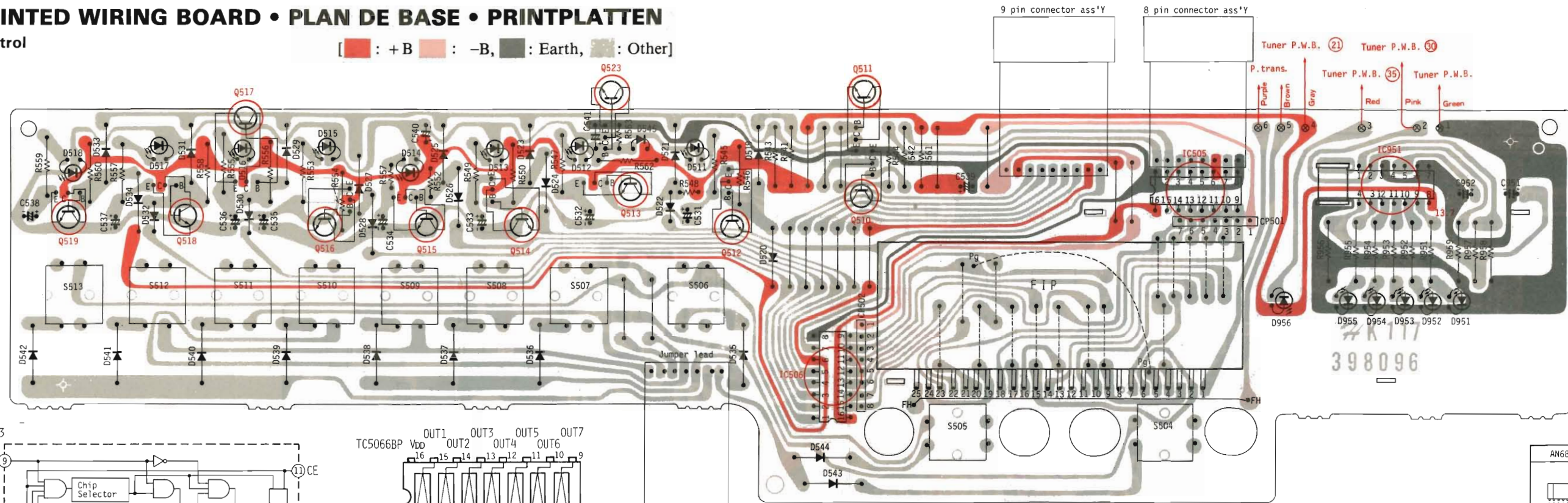

AN6821	25D330AL
HA11211	25C454 25C460 25A836
HA1196 MN1203 MN6142 TC5067BP TC5066BP	1S2473 HZ-3 HZ-5 HZ-6 HZ-7 HZ-9 HZ-12 HZ-15 HZ-24 HZ-30
MN1400SJ	IN60P IN34A
25K104	ERB12-01R
25C1740LN 25A825	White KV-1221
25D756 25B716	
LB1416	

BLOCK DIAGRAM • SCHEMA • BLOCK SCHEMA

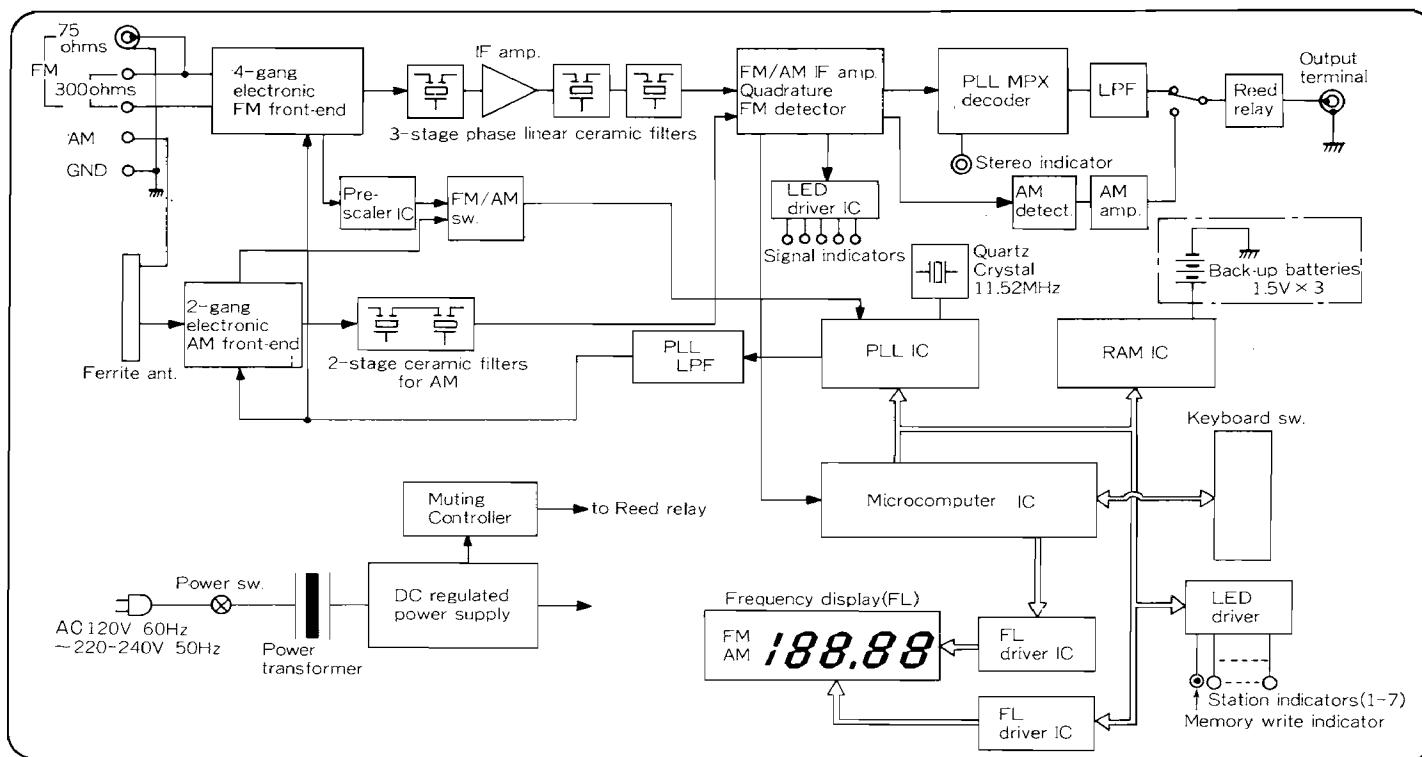

CIRCUIT DIAGRAM • PLAN DE CIRCUIT • SCHALTPLAN

Tuner pack

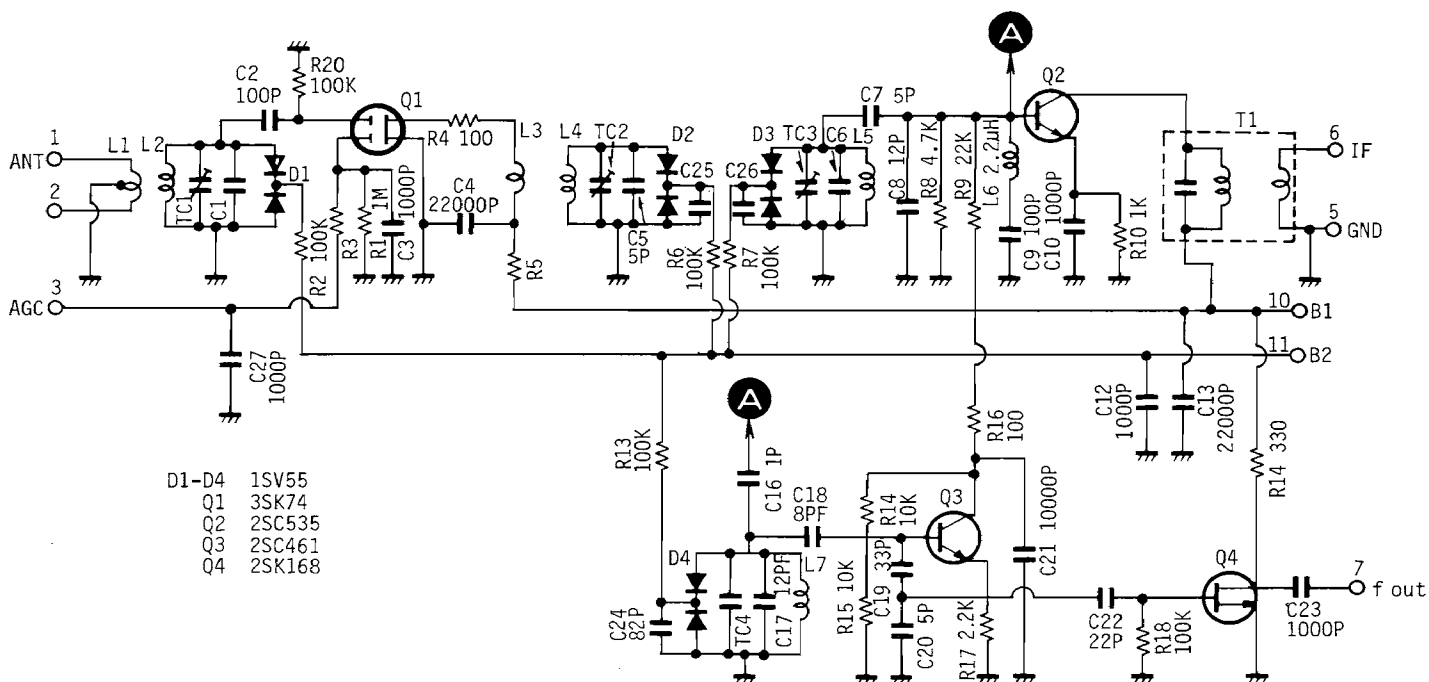

- D1-D4 1SV55
- Q1 3SK74
- Q2 2SC535
- Q3 2SC461
- Q4 2SK168

The circuit diagram is subject to change for improvement without notice.
 Le schéma de montage est sujet à modification sans préavis, pour des raisons d'amélioration.
 Änderungen des Schaltplans im Sinne ständiger Verbesserung vorbehalten.

REPLACEMENT PARTS LIST • TABLEAU DES PIECES • ERSATZTEILLISTE

SYMBOL NO.	STOCK NO.	DESCRIPTION			SYMBOL NO.	STOCK NO.	DESCRIPTION			
CAPACITORS										
for TUNER PRINTED WIRING BOARD										
C101	H230026	Cylindrical ceramic	39 pF	±5%	50 V	C308	0252521	Electrolytic	10 μF	16 V
C102	H230026	Cylindrical ceramic	39 pF	±5%	50 V	C309	0252521	Electrolytic	10 μF	16 V
C103	0252521	Electrolytic	10 μF		16 V	C310	0274222	Mylar, film	1600 pF ±5%	50 V
C104	H240108	Cylindrical ceramic	0.022 μF	±30%	16 V				(for U.S.A. & Canada)	
C105	H240108	Cylindrical ceramic	0.022 μF	±30%	16 V	C311	0274222	Mylar, film	1600 pF ±5%	50 V
C106	H240108	Cylindrical ceramic	0.022 μF	±30%	16 V				(for U.S.A. & Canada)	
C107	0252811	Electrolytic	1 μF		50 V	C310	0274221	Mylar, film	1100 pF ±5%	50 V
C108	H240108	Cylindrical ceramic	0.022 μF	±30%	16 V				(except for U.S.A. & Canada)	
C109	0257182	Electrolytic	2.2 μF		50 V	C311	0274221	Mylar, film	1100 pF ±5%	50 V
C110	0252532	Electrolytic	220 μF		16 V				(except for U.S.A. & Canada)	
C151	H230162	Cylindrical ceramic	10 pF	±5%	50 V	C312	0252813	Electrolytic	3.3 μF	50 V
C152	0244175	Ceramic, discal	0.047 μF	$\begin{smallmatrix} +80 \\ -20 \end{smallmatrix}$	50 V	C313	0252813	Electrolytic	3.3 μF	50 V
C153	H240108	Cylindrical ceramic	0.022 μF	±30%	16 V	C314	0274233	Mylar, film	2700 pF ±5%	50 V
C154	H240108	Cylindrical ceramic	0.022 μF	±30%	16 V				(for U.S.A. & Canada)	
C155	0228428	Styrol	510 pF	±5%	50 V	C315	0274233	Mylar, film	2700 pF ±5%	50 V
C156	0244173	Ceramic, discal	0.022 μF	$\begin{smallmatrix} +80 \\ -20 \end{smallmatrix}$	50 V				(for U.S.A. & Canada)	
C157	0244173	Ceramic, discal	0.022 μF	$\begin{smallmatrix} +80 \\ -20 \end{smallmatrix}$	50 V	C316	0248726	Ceramic, discal	120 pF ±10%	50 V
C159	H240108	Cylindrical ceramic	0.022 μF	±30%	16 V	C501	H240108	Cylindrical ceramic	0.022 μF ±30%	16 V
C160	H240108	Cylindrical ceramic	0.022 μF	±30%	16 V	C502	H240108	Cylindrical ceramic	0.022 μF ±30%	16 V
C161	0252811	Electrolytic	1 μF		50 V	C504	H240108	Cylindrical ceramic	0.022 μF ±30%	16 V
C162	H230073	Cylindrical ceramic	30 pF	±5%	50 V	C505	0252521	Electrolytic	10 μF	16 V
C163	0276011	Mylar, film	0.1 μF	±10%	50 V	C506	H240108	Cylindrical ceramic	0.022 μF ±30%	16 V
C164	0244173	Ceramic, discal	0.022 μF	$\begin{smallmatrix} +80 \\ -20 \end{smallmatrix}$	50 V	C507	H240108	Cylindrical ceramic	0.022 μF ±30%	16 V
C165	0275016	Mylar, film	0.068 μF	±10%	50 V	C508	H240108	Cylindrical ceramic	0.022 μF ±30%	16 V
C201	H240108	Cylindrical ceramic	0.022 μF	±30%	16 V	C509	H240108	Cylindrical ceramic	0.022 μF ±30%	16 V
C202	0252522	Electrolytic	22 μF		16 V	C510	H240108	Cylindrical ceramic	0.022 μF ±30%	16 V
C203	H240108	Cylindrical ceramic	0.022 μF	±30%	16 V	C511	0252723	Electrolytic	33 μF	35 V
C204	0252875	Electrolytic	0.47 μF		50 V	C512	H240108	Cylindrical ceramic	0.022 μF ±30%	16 V
C205	0244175	Ceramic, discal	0.047 μF	$\begin{smallmatrix} +80 \\ -20 \end{smallmatrix}$	50 V	C513	0275211	Mylar, film	0.01 μF ±5%	50 V
C206	0248726	Ceramic, discal	120 pF	±10%	50 V	C514	0252878	Electrolytic	2.2 μF	50 V
C207	0244175	Ceramic, discal	0.047 μF	$\begin{smallmatrix} +80 \\ -20 \end{smallmatrix}$	50 V	C515	0252225	Electrolytic	47 μF	6.3 V
C208	H240108	Cylindrical ceramic	0.022 μF	±30%	16 V	C516	H240108	Cylindrical ceramic	0.022 μF ±30%	16 V
C209	0252876	Electrolytic	0.68 μF		50 V	C517	0244175	Ceramic, discal	0.047 μF $\begin{smallmatrix} +80 \\ -20 \end{smallmatrix}$	50 V
C210	0252813	Electrolytic	3.3 μF		50 V	C518	0246448	Ceramic, discal	22 pF ±5%	50 V
C211	0252811	Electrolytic	1 μF		50 V	C519	0246420	Ceramic, discal	10 pF ± 0.25 pF	50 V
C212	0244175	Ceramic, discal	0.047 μF	$\begin{smallmatrix} +80 \\ -20 \end{smallmatrix}$	50 V	C520	0252522	Electrolytic	22 μF	16 V
C213	0244175	Ceramic, discal	0.047 μF	$\begin{smallmatrix} +80 \\ -20 \end{smallmatrix}$	50 V	C521	0252875	Electrolytic	0.47 μF	50 V
C214	0252811	Electrolytic	1 μF		50 V	C522	0245018	Ceramic, discal	0.022 μF $\begin{smallmatrix} +80 \\ -20 \end{smallmatrix}$	25 V
C215	0248724	Ceramic, discal	100 pF	±10%	50 V	C523	0245018	Ceramic, discal	0.022 μF $\begin{smallmatrix} +80 \\ -20 \end{smallmatrix}$	25 V
C216	H240106	Cylindrical ceramic	0.01 μF	±30%	16 V	C524	0245018	Ceramic, discal	0.022 μF $\begin{smallmatrix} +80 \\ -20 \end{smallmatrix}$	25 V
C217	H240106	Cylindrical ceramic	0.01 μF	±30%	16 V	C525	0245018	Ceramic, discal	0.022 μF $\begin{smallmatrix} +80 \\ -20 \end{smallmatrix}$	25 V
C218	H240108	Cylindrical ceramic	0.022 μF	±30%	16 V	C526	0276013	Mylar, film	0.22 μF ±5%	50 V
C219	H240106	Cylindrical ceramic	0.01 μF	±30%	16 V	C529	0252811	Electrolytic	1 μF	50 V
C220	0252871	Electrolytic	0.1 μF		50 V	C530	0252525	Electrolytic	47 μF	16 V
C221	0275015	Mylar, film	0.047 μF	±10%	50 V	C545	0252231	Electrolytic	100 μF	6.3 V
C222	0252531	Electrolytic	100 μF		16 V	C546	0279975	Mylar, film	0.47 μF ±10%	100 V
C223	0252876	Electrolytic	0.68 μF		50 V	C547	H240108	Cylindrical ceramic	0.022 μF ±30%	16 V
C224	0252523	Electrolytic	33 μF		16 V	C548	0248662	Ceramic, discal	12 pF ±5%	50 V
C225	0275013	Mylar, film	0.022 μF	±10%	50 V	C549	0244173	Ceramic, discal	0.022 μF $\begin{smallmatrix} +80 \\ -20 \end{smallmatrix}$	50 V
C226	0252522	Electrolytic	22 μF		16 V	C550	0246417	Ceramic, discal	7 pF ± 0.25 pF	50 V
C301	0221523	Styrol	360 pF	±5%	50 V	C552	0248726	Ceramic, discal	120 pF ±10%	50 V
C302	0244175	Ceramic, discal	0.047 μF	$\begin{smallmatrix} +80 \\ -20 \end{smallmatrix}$	50 V	C801	0245408	Ceramic, discal	0.01 μF ±20%	500 V
C303	0252812	Electrolytic	2.2 μF		50 V	C802	0245408	Ceramic, discal	0.01 μF ±20%	500 V
C304	0252811	Electrolytic	1 μF		50 V	C803	0245408	Ceramic, discal	0.01 μF ±20%	500 V
C305	0252873	Electrolytic	0.22 μF		50 V	C804	0245408	Ceramic, discal	0.01 μF ±20%	500 V
C306	0252535	Electrolytic	470 μF		16 V	C805	0252825	Electrolytic	47 μF	50 V
C307	0252521	Electrolytic	10 μF		16 V	C806	0252825	Electrolytic	47 μF	50 V
						C807	0244171	Ceramic, discal	0.01 μF ±80%	50 V

SYMBOL NO.	STOCK NO.	DESCRIPTION			SYMBOL NO.	STOCK NO.	DESCRIPTION				
C808	0244171	Ceramic, discal	0.01 μ F	$\pm\frac{80}{20}\%$	50 V	R203	H129575	Carbon film	390 Ω	$\pm 5\%$	SRD1/8P
C809	0252825	Electrolytic	47 μ F		50 V	R204	H129547	Carbon film	47 Ω	$\pm 5\%$	SRD1/8P
C810	0252825	Electrolytic	47 μ F		50 V	R205	H129609	Carbon film	2.2 k Ω	$\pm 5\%$	SRD1/8P
C811	0252731	Electrolytic	100 μ F		35 V	R206	H129601	Carbon film	1 k Ω	$\pm 5\%$	SRD1/8P
C812	0252731	Electrolytic	100 μ F		35 V	R207	H129575	Carbon film	390 Ω	$\pm 5\%$	SRD1/8P
C813	0252621	Electrolytic	10 μ F		25 V	R209	H129561	Carbon film	100 Ω	$\pm 5\%$	SRD1/8P
C814	0252721	Electrolytic	10 μ F		35 V	R211	H129609	Carbon film	2.2 k Ω	$\pm 5\%$	SRD1/8P
C815	0252636	Electrolytic	1000 μ F		25 V	R212	0138139	Carbon film	5.6 k Ω	$\pm 5\%$	SRD1/4P
C816	0252522	Electrolytic	22 μ F		16 V	R213	H129647	Carbon film	47 k Ω	$\pm 5\%$	SRD1/8P
C817	0252522	Electrolytic	22 μ F		16 V	R214	H129569	Carbon film	220 Ω	$\pm 5\%$	SRD1/8P
C818	0252811	Electrolytic	1 μ F		50 V	R216	0110610	Metal (Fuse resistor)	56 Ω	$\pm 5\%$	RN $\frac{1}{4}$ B
C901	0252525	Electrolytic	47 μ F		16 V	R217	H129649	Carbon film	56 k Ω	$\pm 5\%$	SRD1/8P
C902	0252521	Electrolytic	10 μ F		16 V	R218	H129609	Carbon film	2.2 k Ω	$\pm 5\%$	SRD1/8P
C903	0252521	Electrolytic	10 μ F		16 V	R221	0129665	Carbon film	150 k Ω	$\pm 5\%$	SRD1/8P
C904	0252521	Electrolytic	10 μ F		16 V	R222	H129619	Carbon film	5.6 k Ω	$\pm 5\%$	SRD1/8P
C905	0252521	Electrolytic	10 μ F		16 V	R223	H129575	Carbon film	390 Ω	$\pm 5\%$	SRD1/8P
for CONTROL PRINTED WIRING BOARD											
C531	0252521	Electrolytic	10 μ F		16 V	R224	H129643	Carbon film	33 k Ω	$\pm 5\%$	SRD1/8P
C532	0252521	Electrolytic	10 μ F		16 V	R225	H129609	Carbon film	2.2 k Ω	$\pm 5\%$	SRD1/8P
C533	0252521	Electrolytic	10 μ F		16 V	R226	H129641	Carbon film	27 k Ω	$\pm 5\%$	SRD1/8P
C534	0252521	Electrolytic	10 μ F		16 V	R227	H129609	Carbon film	2.2 k Ω	$\pm 5\%$	SRD1/8P
C535	0252521	Electrolytic	10 μ F		16 V	R228	H129619	Carbon film	5.6 k Ω	$\pm 5\%$	SRD1/8P
C536	0252521	Electrolytic	10 μ F		16 V	R229	H129633	Carbon film	12 k Ω	$\pm 5\%$	SRD1/8P
C537	0252521	Electrolytic	10 μ F		16 V	R231	H129613	Carbon film	3.3 k Ω	$\pm 5\%$	SRD1/8P
C538	0252521	Electrolytic	10 μ F		16 V	R232	H129671	Carbon film	270 k Ω	$\pm 5\%$	SRD1/8P
C539	0252521	Electrolytic	10 μ F		16 V	R233	H129661	Carbon film	100 k Ω	$\pm 5\%$	SRD1/8P
C540	0252525	Electrolytic	47 μ F		16 V	R234	H129601	Carbon film	1 k Ω	$\pm 5\%$	SRD1/8P
C541	0252225	Electrolytic	47 μ F		6.3 V	R235	H129651	Carbon film	68 k Ω	$\pm 5\%$	SRD1/8P
C951	0252813	Electrolytic	3.3 μ F		50 V	R236	H129641	Carbon film	27 k Ω	$\pm 5\%$	SRD1/8P
C952	0252521	Electrolytic	10 μ F		16 V	R237	H129631	Carbon film	10 k Ω	$\pm 5\%$	SRD1/8P
RESISTORS											
for TUNER PRINTED WIRING BOARD											
R101	H129649	Carbon film	56 k Ω	$\pm 5\%$	SRD1/8P	R239	H129669	Carbon film	220 k Ω	$\pm 5\%$	SRD1/8P
R102	H129661	Carbon film	100 k Ω	$\pm 5\%$	SRD1/8P	R240	H129561	Carbon film	100 Ω	$\pm 5\%$	SRD1/8P
R103	H129603	Carbon film	1.2 k Ω	$\pm 5\%$	SRD1/8P	R241	H129609	Carbon film	2.2 k Ω	$\pm 5\%$	SRD1/8P
R104	H129631	Carbon film	10 k Ω	$\pm 5\%$	SRD1/8P	R302	0110820	Metal	24 k Ω	$\pm 1\%$	RN $\frac{1}{4}$ B
R105	H129661	Carbon film	100 k Ω	$\pm 5\%$	SRD1/8P	R303	H129601	Carbon film	1 k Ω	$\pm 5\%$	SRD1/8P
R106	H129651	Carbon film	68 k Ω	$\pm 5\%$	SRD1/8P	R304	H129665	Carbon film	150 k Ω	$\pm 5\%$	SRD1/8P
R107	H129561	Carbon film	100 Ω	$\pm 5\%$	SRD1/8P	R305	H129665	Carbon film	150 k Ω	$\pm 5\%$	SRD1/8P
R108	0110609	Metal (Fuse resistor)	47 Ω	$\pm 5\%$	RN $\frac{1}{4}$ B	R306	H129631	Carbon film	10 k Ω	$\pm 5\%$	SRD1/8P
R109	H129631	Carbon film	10 k Ω	$\pm 5\%$	SRD1/8P	R307	0134373	Composition	1 k Ω	$\pm 10\%$	RC $\frac{1}{2}$ GF
R110	H129631	Carbon film	10 k Ω	$\pm 5\%$	SRD1/8P	R308	H129645	Carbon film	39 k Ω	$\pm 5\%$	SRD1/8P
R151	H129561	Carbon film	100 Ω	$\pm 5\%$	SRD1/8P	R309	H129553	Carbon film	82 Ω	$\pm 5\%$	SRD1/8P
R152	H129621	Carbon film	6.8 k Ω	$\pm 5\%$	SRD1/8P	R310	H129643	Carbon film	33 k Ω	$\pm 5\%$	SRD1/8P
R153	H129549	Carbon film	56 Ω	$\pm 5\%$	SRD1/8P	R311	H129643	Carbon film	33 k Ω	$\pm 5\%$	SRD1/8P
R154	H129605	Carbon film	1.5 k Ω	$\pm 5\%$	SRD1/8P	R312	H129621	Carbon film	6.8 k Ω	$\pm 5\%$	SRD1/8P
R155	H129669	Carbon film	220 k Ω	$\pm 5\%$	SRD1/8P	R313	H129621	Carbon film	6.8 k Ω	$\pm 5\%$	SRD1/8P
R156	H129631	Carbon film	10 k Ω	$\pm 5\%$	SRD1/8P	R315	H129647	Carbon film	47 k Ω	$\pm 5\%$	SRD1/8P
R157	H129631	Carbon film	10 k Ω	$\pm 5\%$	SRD1/8P	R316	H129647	Carbon film	47 k Ω	$\pm 5\%$	SRD1/8P
R159	H129609	Carbon film	2.2 k Ω	$\pm 5\%$	SRD1/8P	R317	H129613	Carbon film	3.3 k Ω	$\pm 5\%$	SRD1/8P
R160	H129609	Carbon film	2.2 k Ω	$\pm 5\%$	SRD1/8P	R318	H129613	Carbon film	3.3 k Ω	$\pm 5\%$	SRD1/8P
R161	H129651	Carbon film	68 k Ω	$\pm 5\%$	SRD1/8P	R319	H129613	Carbon film	3.3 k Ω	$\pm 5\%$	SRD1/8P
R162	H129605	Carbon film	1.5 k Ω	$\pm 5\%$	SRD1/8P	R320	H129613	Carbon film	3.3 k Ω	$\pm 5\%$	SRD1/8P
R163	H129673	Carbon film	330 k Ω	$\pm 5\%$	SRD1/8P	R321	H129637	Carbon film	18 k Ω	$\pm 5\%$	SRD1/8P
R164	0129631	Carbon film	10 k Ω	$\pm 5\%$	SRD1/8P	(except for U.S.A. & Canada)					
R201	H129561	Carbon film	100 Ω	$\pm 5\%$	SRD1/8P	R501	0114145	Carbon film	390 Ω	$\pm 5\%$	SRD $\frac{1}{4}$ P
						R502	H129613	Carbon film	3.3 k Ω	$\pm 5\%$	SRD1/8P

HITACHI FT-5000

SYMBOL NO.	STOCK NO.	DESCRIPTION			SYMBOL NO.	STOCK NO.	DESCRIPTION			
R503	H129631	Carbon film	10 kΩ	±5%	SRD1/8P	R901	H129639	Carbon film	22 kΩ ±5%	SRD1/8P
R504	H129673	Carbon film	330 kΩ	±5%	SRD1/8P	R902	H129647	Carbon film	47 kΩ ±5%	SRD1/8P
R505	H129651	Carbon film	68 kΩ	±5%	SRD1/8P	R903	H129651	Carbon film	68 kΩ ±5%	SRD1/8P
R506	H129621	Carbon film	6.8 kΩ	±5%	SRD1/8P	R904	H129661	Carbon film	100 kΩ ±5%	SRD1/8P
R507	H129601	Carbon film	1 kΩ	±5%	SRD1/8P	R906	H129631	Carbon film	10 kΩ ±5%	SRD1/8P
R508	H129645	Carbon film	39 kΩ	±5%	SRD1/8P	R907	H129547	Carbon film	47 Ω ±5%	SRD1/8P
R509	H129575	Carbon film	390 Ω	±5%	SRD1/8P	R908	H129661	Carbon film	100 kΩ ±5%	SRD1/8P
R510	H129673	Carbon film	330 kΩ	±5%	SRD1/8P	R909	H129661	Carbon film	100 kΩ ±5%	SRD1/8P
R511	H129621	Carbon film	6.8 kΩ	±5%	SRD1/8P	R910	H129661	Carbon film	100 kΩ ±5%	SRD1/8P
R512	H129561	Carbon film	100 Ω	±5%	SRD1/8P	R911	0129661	Carbon film	100 kΩ ±5%	SRD1/8P
R513	H129631	Carbon film	10 kΩ	±5%	SRD1/8P	R912	H129639	Carbon film	22 kΩ ±5%	SRD1/8P
R514	H129613	Carbon film	3.3 kΩ	±5%	SRD1/8P	R913	H129601	Carbon film	1 kΩ ±5%	SRD1/8P
R515	H129631	Carbon film	10 kΩ	±5%	SRD1/8P	R914	H129631	Carbon film	10 kΩ ±5%	SRD1/8P
R516	H129601	Carbon film	1 kΩ	±5%	SRD1/8P	R915	H129661	Carbon film	100 kΩ ±5%	SRD1/8P
R517	H129565	Carbon film	150 Ω	±5%	SRD1/8P	R916	H129645	Carbon film	39 kΩ ±5%	SRD1/8P
R518	H129661	Carbon film	100 kΩ	±5%	SRD1/8P	R917	H129665	Carbon film	150 kΩ ±5%	SRD1/8P
R519	H129631	Carbon film	10 kΩ	±5%	SRD1/8P	R001	0139005	Composition	2.7 MΩ ±10%	RC½GF (for U.S.A. & Canada)
R520	H129601	Carbon film	1 kΩ	±5%	SRD1/8P	for CONTROL PRINTED WIRING BOARD				
R521	H129647	Carbon film	47 kΩ	±5%	SRD1/8P	R541	H129631	Carbon film	10 kΩ ±5%	SRD1/8P
R522	H129607	Carbon film	1.8 kΩ	±5%	SRD1/8P	R542	H129661	Carbon film	100 kΩ ±5%	SRD1/8P
R523	H129661	Carbon film	100 kΩ	±5%	SRD1/8P	R543	H129631	Carbon film	10 kΩ ±5%	SRD1/8P
R524	H129617	Carbon film	4.7 kΩ	±5%	SRD1/8P	R544	H129661	Carbon film	100 kΩ ±5%	SRD1/8P
R525	H129617	Carbon film	4.7 kΩ	±5%	SRD1/8P	R545	H129577	Carbon film	470 Ω ±5%	SRD1/8P
R526	H129631	Carbon film	10 kΩ	±5%	SRD1/8P	R546	H129631	Carbon film	10 kΩ ±5%	SRD1/8P
R527	H129617	Carbon film	4.7 kΩ	±5%	SRD1/8P	R547	H129577	Carbon film	470 Ω ±5%	SRD1/8P
R528	H129617	Carbon film	4.7 kΩ	±5%	SRD1/8P	R548	0129631	Carbon film	10 kΩ ±5%	SRD1/8P
R529	H129617	Carbon film	4.7 kΩ	±5%	SRD1/8P	R549	H129577	Carbon film	470 Ω ±5%	SRD1/8P
R530	H129641	Carbon film	27 kΩ	±5%	SRD1/8P	R550	H129631	Carbon film	10 kΩ ±5%	SRD1/8P
R531	H129641	Carbon film	27 kΩ	±5%	SRD1/8P	R551	0129577	Carbon film	470 Ω ±5%	SRD1/8P
R532	H129641	Carbon film	27 kΩ	±5%	SRD1/8P	R552	0129631	Carbon film	10 kΩ ±5%	SRD1/8P
R533	H129641	Carbon film	27 kΩ	±5%	SRD1/8P	R553	H129577	Carbon film	470 Ω ±5%	SRD1/8P
R534	H129647	Carbon film	47 kΩ	±5%	SRD1/8P	R554	H129631	Carbon film	10 kΩ ±5%	SRD1/8P
R535	H129645	Carbon film	39 kΩ	±5%	SRD1/8P	R555	H129577	Carbon film	470 Ω ±5%	SRD1/8P
R536	H129637	Carbon film	18 kΩ	±5%	SRD1/8P	R556	H129631	Carbon film	10 kΩ ±5%	SRD1/8P
R537	H129651	Carbon film	68 kΩ	±5%	SRD1/8P	R557	H129577	Carbon film	470 Ω ±5%	SRD1/8P
R538	H129661	Carbon film	100 kΩ	±5%	SRD1/8P	R558	H129631	Carbon film	10 kΩ ±5%	SRD1/8P
R539	H129661	Carbon film	100 kΩ	±5%	SRD1/8P	R559	H129577	Carbon film	470 Ω ±5%	SRD1/8P
R540	0129639	Carbon film	22 kΩ	±5%	SRD1/8P	R560	H129631	Carbon film	10 kΩ ±5%	SRD1/8P
R570	H129631	Carbon film	10 kΩ	±5%	SRD1/8P	R561	0129531	Carbon film	10 Ω ±5%	SRD1/8P
R571	H129647	Carbon film	47 kΩ	±5%	SRD1/8P	R562	0129661	Carbon film	100 kΩ ±5%	SRD1/8P
R572	H129601	Carbon film	1 kΩ	±5%	SRD1/8P	R563	0129639	Carbon film	22 kΩ ±5%	SRD1/8P
R573	H129563	Carbon film	120 Ω	±5%	SRD1/8P	R951	H129551	Carbon film	68 Ω ±5%	SRD1/8P
R574	H129637	Carbon film	18 kΩ	±5%	SRD1/8P	R952	H129551	Carbon film	68 Ω ±5%	SRD1/8P
R575	H129661	Carbon film	100 kΩ	±5%	SRD1/8P	R953	H129551	Carbon film	68 Ω ±5%	SRD1/8P
R801	H129617	Carbon film	4.7 kΩ	±5%	SRD1/8P	R954	H129551	Carbon film	68 Ω ±5%	SRD1/8P
R802	0114177	Carbon film	4.7 kΩ	±5%	SRD1/8P	R955	H129551	Carbon film	68 Ω ±5%	SRD1/8P
R803	H129631	Carbon film	10 kΩ	±5%	SRD1/8P	R956	H129635	Carbon film	15 kΩ ±5%	SRD1/8P
R804	H129631	Carbon film	10 kΩ	±5%	SRD1/8P	R957	0129654	Carbon film	91 kΩ ±5%	SRD1/8P
R805	H129635	Carbon film	15 kΩ	±5%	SRD1/8P	R958	H129631	Carbon film	10 kΩ ±5%	SRD1/8P
R806	H129609	Carbon film	2.2 kΩ	±5%	SRD1/8P	R959	H129631	Carbon film	10 kΩ ±5%	SRD1/8P
R807	H129601	Carbon film	1 kΩ	±5%	SRD1/8P	ICs & TRANSISTORS				
R808	H129605	Carbon film	1.5 kΩ	±5%	SRD1/8P	for TUNER PRINTED WIRING BOARD				
R809	H129631	Carbon film	10 kΩ	±5%	SRD1/8P	IC201	2367281	HA11211		
R810	H129609	Carbon film	2.2 kΩ	±5%	SRD1/8P	IC301	2367271	HA1196		
R812	H129601	Carbon film	1 kΩ	±5%	SRD1/8P	IC501	2368011	AN6821		
R813	H129665	Carbon film	150 kΩ	±5%	SRD1/8P					
R814	H129673	Carbon film	330 kΩ	±5%	SRD1/8P					
R815	H129631	Carbon film	10 kΩ	±5%	SRD1/8P					
R816	H129631	Carbon film	10 kΩ	±5%	SRD1/8P					
R817	H129617	Carbon film	4.7 kΩ	±5%	SRD1/8P					
R818	H129577	Carbon film	470 Ω	±5%	SRD1/8P					

SYMBOL NO.	STOCK NO.	DESCRIPTION	SYMBOL NO.	STOCK NO.	DESCRIPTION
IC502	2367991	MN6142	DIODES		
IC503	2368001	MN1203			
IC504	2367981	MN1400SJ	for TUNER PRINTED WIRING BOARD		
Q101	2328803	2SK104 (H)			
Q102	2328653	2SC1740LN (E)	D101	2337601	1S2473
Q151	0573491	2SC454 (B)	D102	2337601	1S2473
Q201	0573486	2SC460 (B)	D103	0575019	1N60P
Q202	2328652	2SC1740LN (S)	D104	0575019	1N60P
Q203	2328652	2SC1740LN (S)	D151	2337841	KV-1221
Q501	0573486	2SC460 (B)	D201	2337601	1S2473
Q502	0573486	2SC460 (B)	D202	2337601	1S2473
Q503	2328653	2SC1740LN (E)	D203	2337601	1S2473
Q504	2328653	2SC1740LN (E)	D204	0575002	1N34A
Q505	2328802	2SK104 (F)	D205	0575002	1N34A
Q506	2328652	2SC1740LN (S)	D206	2337601	1S2473
Q507	2328652	2SC1740LN (S)	D301	2337601	1S2473
Q508	2328652	2SC1740LN (S)	D302	2337601	1S2473
Q509	2328652	2SC1740LN (S)	D501	2337601	1S2473
Q520	2328652	2SC1740LN (S)	D502	2337601	1S2473
Q521	2327743	2SA836 (E)	D503	0575002	1N34A
Q522	2328653	2SC1740LN (E)	D504	0575002	1N34A
Q530	2328652	2SC1740LN (S)	D505	2337601	1S2473
Q531	2327743	2SA836 (E)	D507	2337601	1S2473
Q801	2328872	2SD756 (E)	D508	2337601	1S2473 (except for U.S.A. & Canada)
Q802	2328862	2SB716 (E)	D509	2337601	1S2473
Q803	2328652	2SC1740LN (S)	D510	2337601	1S2473
Q804	2328973	2SD330AL (E)	D551	2337601	1S2473
Q805	2328973	2SD330AL (E)	D552	2337601	1S2473
Q806	2328973	2SD330AL (E)	D801	2337761	ERB12-01R
Q807	2328642	2SA825 (Q)	D802	2337761	ERB12-01R
Q808	2328652	2SC1740LN (S)	D803	2337761	ERB12-01R
Q901	2328642	2SA825 (Q)	D804	2337761	ERB12-01R
Q902	2328652	2SC1740LN (S)	D805	2337761	ERB12-01R
Q903	2328652	2SC1740LN (S)	D806	2337761	ERB12-01R
Q904	2328642	2SA825 (Q)	D807	2337761	ERB12-01R
Q905	2328652	2SC1740LN (S)	D808	2337761	ERB12-01R
Q906	2328652	2SC1740LN (S)	D901	2337601	1S2473
for CONTROL PRINTED WIRING BOARD			D902	2337601	1S2473
IC505	2368021	TC5067BP	D903	2337601	1S2473
IC506	2367631	TC5066BP	D904	2337601	1S2473
IC951	2367901	LB1416	D905	2337601	1S2473
Q510	2328652	2SC1740LN (S)	D906	2337601	1S2473
Q511	2328652	2SC1740LN (S)	D907	2337601	1S2473
Q512	2328652	2SC1740LN (S)	D908	2337601	1S2473
Q513	2328652	2SC1740LN (S)	D909	2337601	1S2473
Q514	2328652	2SC1740LN (S)	D910	2337601	1S2473
Q515	2328652	2SC1740LN (S)	D911	2337601	1S2473
Q516	2328652	2SC1740LN (S)	D912	2337601	1S2473
Q517	2328652	2SC1740LN (S)	ZD201	2337292	HZ-9 (B) (except for U.S.A. & Canada)
Q518	2328652	2SC1740LN (S)	ZD501	2337587	HZ-5 (C) -1
Q519	2328652	2SC1740LN (S)	ZD502	2337584	HZ-5 (B) -1
Q523	2328653	2SC1740LN (E)	ZD503	2337102	HZ-12 (B)
			ZD801	2337186	HZ-30-3

HITACHI FT-5000

SYMBOL NO.	STOCK NO.	DESCRIPTION	SYMBOL NO.	STOCK NO.	DESCRIPTION
ZD802	2337185	HZ-24-3	COILS & TRANSFORMERS		
ZD803	2337122	HZ-6 (B)			
ZD804	2337292	HZ-9 (B)			
ZD805	2337532	HZ-15-2			
ZD806	2337547	HZ-7 (C) -1			
ZD807	2337615	HZ-3 (B) -2			
for CONTROL PRINTED WIRING BOARD					
D511	2337731	LED (TLR205)	L151	2227353	Choke coil-100 μ H
D512	2337731	LED (TLR205)	L202	2227351	Choke coil-1 μ H
D513	2337731	LED (TLR205)	L501	2227033	Choke coil-10 μ H
D514	2337731	LED (TLR205)	L502	2227034	Choke coil-22 μ H
D515	2337731	LED (TLR205)	L503	2227034	Choke coil-22 μ H
D516	2337731	LED (TLR205)	L504	2227033	Choke coil-10 μ H
D517	2337731	LED (TLR205)	L505	2227033	Choke coil-10 μ H
D518	2337731	LED (TLR205)	L506	2227033	Choke coil-10 μ H
D519	2337601	1S2473	L507	2227033	Choke coil-10 μ H
D520	2337601	1S2473	L508	2227033	Choke coil-10 μ H
D521	2337601	1S2473	L509	2227033	Choke coil-10 μ H
D522	2337601	1S2473	L510	2227033	Choke coil-10 μ H
D523	2337601	1S2473	L511	2227033	Choke coil-10 μ H
D524	2337601	1S2473	L512	2227033	Choke coil-10 μ H
D525	2337601	1S2473	L513	2227033	Choke coil-10 μ H
D526	2337601	1S2473	L514	2227033	Choke coil-10 μ H
D527	2337601	1S2473	L515	2227033	Choke coil-10 μ H
D528	2337601	1S2473	L516	2227353	Choke coil-100 μ H
D529	2337601	1S2473	T151	2135041	AM OSC coil
D530	2337601	1S2473	T152	2154401	AM IF transformer
D531	2337601	1S2473	T201	2154431	FM discri. transformer
D532	2337601	1S2473	T202	2154432	FM discri. transformer
D533	2337601	1S2473	T203	2154122	AM IF transformer
D534	2337601	1S2473	MISCELLANEOUS		
D535	2337601	1S2473		2507941	Tuner P.W.B. ass'y (for U.S.A. & Canada)
D536	2337601	1S2473		2507942	Tuner P.W.B. ass'y (except for U.S.A. & Canada)
D537	2337601	1S2473		2507951	Control P.W.B. ass'y
D538	2337601	1S2473		2425141	Tuner pack
D539	2337601	1S2473	MF151	2154411	Ceramic filter
D540	2337601	1S2473	MF201	2134992	Ceramic filter
D541	2337601	1S2473	MF202	2134992	Ceramic filter
D542	2337601	1S2473	MF203	2134992	Ceramic filter
D543	2337601	1S2473	MF201	2135002	Ceramic filter
D544	2337601	1S2473	MF202	2135002	Ceramic filter
D545	2337601	1S2473	MF203	2135002	Ceramic filter
D951	2337732	TLG205	X501	2787841	Crystal oscillator (11.52 MHz)
D952	2337732	TLG205	CP301	2135051	Leak filter
D953	2337732	TLG205	CP302	2135051	Leak filter
D954	2337732	TLG205	CP501	0189001	Composition resistor
D955	2337732	TLG205	CP502	0189014	Composiiton resistor
D956	2337731	TLR205	CP503	0189011	Composition resistor
VARIABLE RESISTORS			RY901	2647161	Reed relay
for TUNER PRINTED WIRING BOARD				2667696	7 pin ass'y
R208	0151334	50 k Ω -(B) (for output level adj.)		2667697	8 pin ass'y
R210	0151334	50 k Ω -(B) (for muting width adj.)		2667698	9 pin ass'y
R215	0151335	100 k Ω -(B) (for muting level adj.)		2688081	4P screw terminal (for U.S.A. & Canada)
R230	0151335	100 k Ω -(B) (for FM signal ind. adj.)		2687852	4P screw terminal (except for U.S.A. & Canada)
R301	0151333	10 k Ω -(B) (for FM 76 kHz adj.)		2677391	2P US pin jack
R314	0151336	300 k Ω -(B) (for separation adj.)	S502-3	2638432	Switch-miniature push switch (MODE, FUNCTION)
			S501	2638433	Switch-miniature push switch (SCAN/FM MUTE)

SYMBOL NO.	STOCK NO.	DESCRIPTION							
CT151	0283124	Trimmer capacitor							
	4389211	Heat sink board							
	4575443	3 φ x 10 DT bind screw with washer							
	4575442	3 φ x 8 DT bind screw with washer							
	2638241	Tact switch							
	2787821	Fluorescent display tube							
	2749401	7 pin connector ass'y							
	2749402	8 pin connector ass'y							
	2749404	9 pin connector ass'y							
		for FINAL ASSEMBLY							
	4407721	Cover							
	4399022	3 φ washer							
		for DIAL MECHANISM ASSEMBLY							
	4094321	Escutcheon ass'y	△ S001	2638222	Power switch	○			
3286211	Knob-push knob (POWER)	△ S001	2638221	Power switch	○	○	○	○	
3338598	Spring	△ F801	2727015	Fuse-0.5 A, UL	○				
3286431	Knob ass'y (AM-FM PRESET)	△ F801	2727197	Fuse-T500 mA	○	○	○	○	
3339842	Spring	△ F802	2727198	Fuse-T800 mA	○	○	○	○	
3286321	Knob-push knob (SCAN/FM MUTE, others)	△ F803	2727198	Fuse-T800 mA	○	○	○	○	
3919881	Stopper		3925791	Capacitor cover	○	○	○	○	
3286481	Knob-push knob (TUNING-UP/DOWN)		△ 2219061	Power transformer	○				
4094351	Back plate ass'y		△ 2219071	Power transformer	○	○	○	○	
4410111	Battery cover		△ 2219081	Power transformer				○	
4784106	3 φ x 10 bind tapping screw		0043793	Bushing (for power supply cord)	○				
4567422	4 φ x 8 DT bind screw (P. trans. fixing)		3913001	Bushing (for power supply cord)	○	○		○	
4567432	3 φ x 8 DT bind screw (Black)		3715183	Bushing (for power supply cord)		○			
4567412	3 φ x 8 DT bind screw (Yellow)		3715184	Bushing (for power supply cord)			○		
4567411	3 φ x 6 DT bind screw		△ 2748863	Power supply cord	○				
	for REAR PLATE ASSEMBLY								
L001	4567452	3 φ x 8 DT bind screw	△ 2748751	Power supply cord	○	○		○	
	2134942	AM ferrite antenna	△ 2748741	Power supply cord			○		
	2787831	Battery box	△ 2747302	Power supply cord	○			○	
			△ 2657281	AC outlet	○			○	
			△ 2677461	DIN antenna socket	○	○	○	○	
			△ 2627221	Voltage selector switch				○	
			2657371	E socket adaptor (for ACCESSORY)				○	
			2748544	Patch cord (for ACCESSORY)	○	○	○	○	
			△ CP001	Spark killer	○				
			△ CP001	Spark killer			○	○	
			△ CP002	Spark killer			○	○	
			△ C002	Paper capacitor, 0.01 μF ± 20% 450 V	○	○	○		

**FRONT AND REAR PANEL • PANNEAUX AVANT ET ARRIERE •
VORDERE UND HINTERE BEDIENUNGSTAFEL**

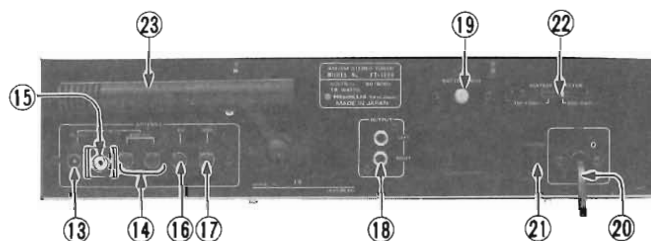
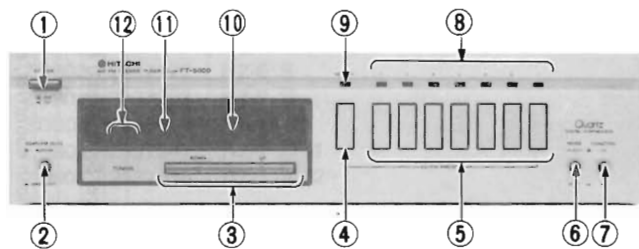

- ① POWER switch
- ② SCAN/FM MUTE switch
- ③ TUNING keys
- ④ MEMORY write key
- ⑤ PRESET keys
- ⑥ MODE switch
- ⑦ FUNCTION switch
- ⑧ Station indicators
- ⑨ MEMORY write indicator
- ⑩ Frequency display
- ⑪ FM STEREO indicator
- ⑫ SIGNAL indicators
- ⑬ FM ANTENNA terminal (75 ohms) (DIN) (for Europe, Asia and Latin America)

- ⑭ FM ANTENNA terminals (300 ohms)
- ⑮ Coaxial cable terminal (75 ohms) (for U.S.A. and Canada)
- ⑯ AM ANTENNA terminal
- ⑰ Ground terminal (GND)
- ⑱ OUTPUT terminals
- ⑲ BATTERY BOX
- ⑳ Power supply cord
- ㉑ AC outlet (for U.S.A., Canada, W. Germany Asia and Latin America)
- ㉒ VOLTAGE SELECTOR (for W.Germany, Asia and Latin America)
- ㉓ AM ferrite antenna

- ① Interrupteur d'alimentation (POWER)
- ② Commutateur de balayage/assourdissement FM (SCAN/FM MUTE)
- ③ Touches de syntonisation (TUNING)
- ④ Touche d'inscription en mémoire (MEMORY)
- ⑤ Touches de programmation (PRESET)
- ⑥ Commutateur de MODE
- ⑦ Sélecteur de fonction (FUNCTION)
- ⑧ Indicateurs de station
- ⑨ Indicateur de mise en mémoire (MEMORY)
- ⑩ Affichage de fréquence
- ⑪ Indicateur FM STEREO
- ⑫ Indicateur du SIGNAL
- ⑬ Bornes d'antenne FM (FM ANTENNA) (75 ohms) (DIN) (pour l'Europe, l'Asie et l'Amérique latine)

- ⑭ Bornes d'antenne FM (FM ANTENNA) (300 ohms)
- ⑮ Bornes pour câble coaxial (75 ohms) (pour les U.S.A. et le Canada)
- ⑯ Bornes d'antenne AM (AM ANTENNA)
- ⑰ Prise de terre (GND)
- ⑱ Bornes de sortie (OUTPUT)
- ⑲ Boîtier de piles (BATTERY BOX)
- ⑳ Cordon d'alimentation CA
- ㉑ Prise de sortie CA (pour les U.S.A. le Canada, l'Allemagne fédérale, l'Asie et les pays d'Amérique latine)
- ㉒ Sélecteur de tension (VOLTAGE SELECTOR) (pour l'Allemagne fédérale, l'Asie et les pays d'Amérique latine)
- ㉓ Antenne ferrite AM

- ① Netzschalter (POWER)
- ② Absuch/UKW-Stummabstimmungs-Schalter (SCAN/FM MUTE)
- ③ Sendereinstelltasten (TUNING)
- ④ Speicherabrufaste (MEMORY)
- ⑤ Stationsvorwahltasten (PRESET)
- ⑥ Betriebsartenschalt (MODE)
- ⑦ Funktionsschalter (FUNCTION)
- ⑧ Stationenindikatoren (STATION INDICATORS)
- ⑨ Speicherindikator (MEMORY INDICATOR)
- ⑩ Frequenzanzeige (FREQUENCY DISPLAY)
- ⑪ FM STEREO Indikator (FM STEREO INDICATOR)
- ⑫ Signalindikator (SIGNAL INDICATOR)
- ⑬ Antennenanschluß (FM ANTENNA) (75 Ohm) (DIN) (Europa, Asien und Lateinamerika)

- ⑬ UKW-Antennenanschluß (FM ANTENNA) (300 Ohm)
- ⑮ Koaxialkabelanschluß (75 Ohm) (für USA und Kanada)
- ⑯ MW-Antennenklemme (AM ANTENNA)
- ⑰ Erdung (GND)
- ⑱ Ausgangsklemmen (OUTPUT)
- ⑲ Batteriebox (BATTERY BOX)
- ⑳ Netzkabel
- ㉑ Netzausgang (AC) (für USA, BRD, Asien und Lateinamerika)
- ㉒ Spannungswahlschalter (VOLTAGE SELECTOR) (für BRD, Asien und Lateinamerika)
- ㉓ MW-Ferritantenne

 **Hitachi, Ltd. Tokyo Japan**

Head Office : 5-1, 1-chome, Marunouchi, Chiyoda-ku, Tokyo, Japan
 Tel. : Tokyo (212) 1111 (80 lines)
 Cable Address : "HITACHY" TOKYO