

# FRONT AND REAR PANEL · VORDERE UND HINTERE BEDIENUNGS TAFEL · PANNEAUX AVANT ET ARRIERE

(HA-4700)

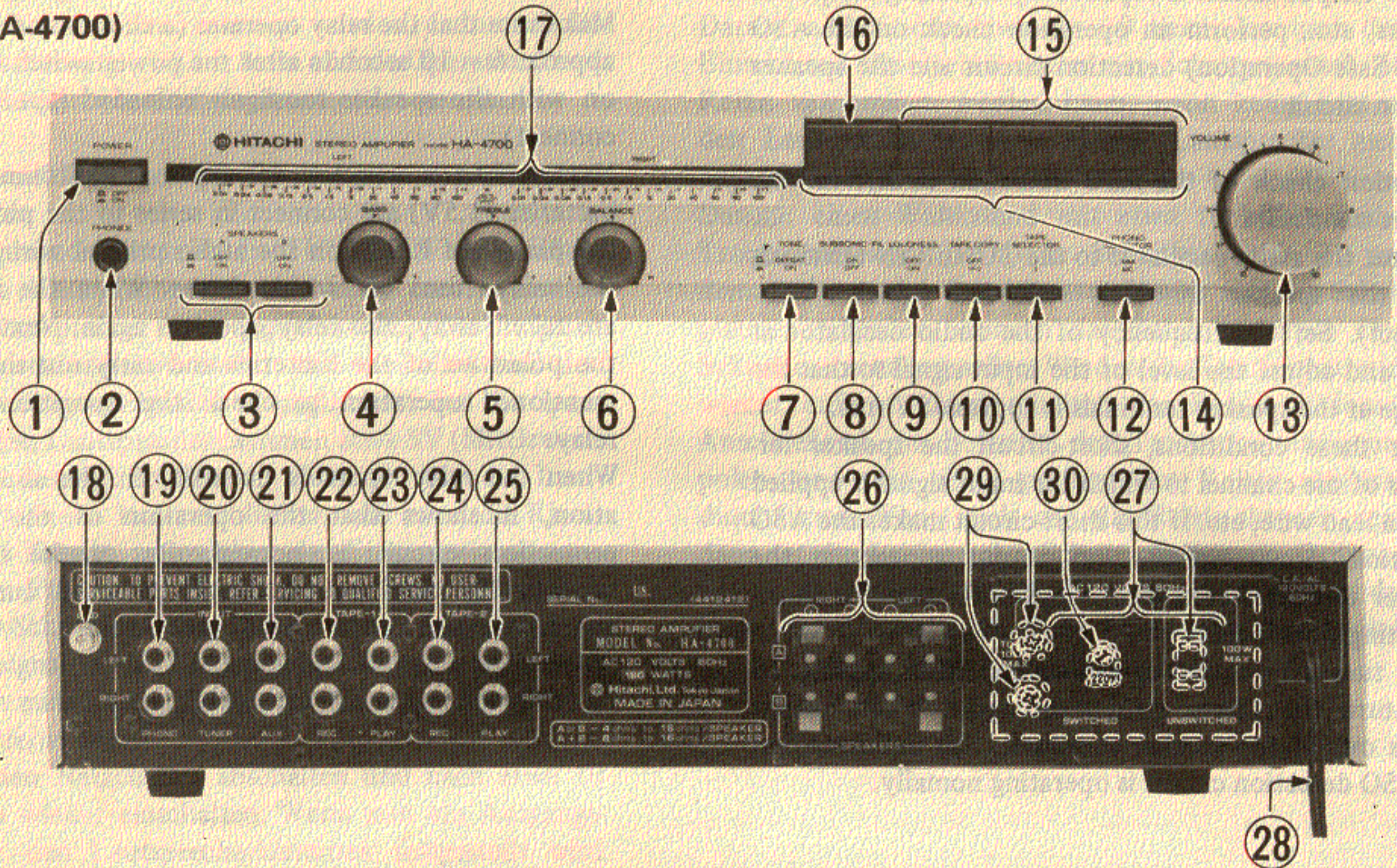

- ① POWER switch
- ② PHONES jack
- ③ SPEAKERS switches
- ④ BASS control
- ⑤ TREBLE control
- ⑥ BALANCE control
- ⑦ TONE switch
- ⑧ SUBSONIC-FILTER switch
- ⑨ LOUDNESS switch
- ⑩ TAPE COPY switch
- ⑪ TAPE SELECTOR switch
- ⑫ PHONO SELECTOR switch
- ⑬ VOLUME control
- ⑭ Program source indicators
- ⑮ FUNCTION switches
- ⑯ TAPE monitor switch
- ⑰ Peak power indicators
- ⑱ Ground terminal (GND)
- ⑲ PHONO INPUT terminals
- ⑳ TUNER INPUT terminals
- ㉑ AUX INPUT terminals
- ㉒ TAPE-1 REC terminals
- ㉓ TAPE-1 PLAY terminals
- ㉔ TAPE-2 REC terminals
- ㉕ TAPE-2 PLAY terminals
- ㉖ SPEAKERS terminals
- ㉗ AC outlet (3 outlets for U.S.A. and Canadian sets, 1 outlet for Asian and Latin American countries sets.)
- ㉘ Power supply cord
- ㉙ FUSE holder (for Asian and Latin American countries)
- ㉚ VOLTAGE SELECTOR (for Asian and Latin American countries)

- ① Netzschalter (POWER)
- ② Kopfhörerstecker (PHONES)
- ③ Lautsprecherschalter (SPEAKERS)
- ④ Tiefenregler (BASS)
- ⑤ Höhenregler (TREBLE)
- ⑥ Balanceregler (BALANCE)
- ⑦ Klangregelschalter (TONE)
- ⑧ Infraschallfilter (SUBSONIC-FILTER)
- ⑨ Gehörriichtige Lautstärke (LOUDNESS)
- ⑩ Tonband-Überspielschalter (TAPE COPY)
- ⑪ Tonband-Wahlschalter (TAPE SELECTOR)
- ⑫ Plattenspielerwahlschalter (PHONO SELECTOR)
- ⑬ Lautstärkereglter (VOLUME)
- ⑭ Programmquellenanzeigen
- ⑮ Funktionswahl-tasten (FUNCTION)
- ⑯ Bandmithörschalter (TAPE MONITOR)
- ⑰ Spitzenpegelanzeigen
- ⑱ Erdklemme (GND)
- ⑲ Plattenspieler-Eingangsbuchsen (PHONO INPUT)
- ⑳ Tuner-Eingangsbuchsen (TUNER INPUT)
- ㉑ Zusatz-Eingangsbuchsen (AUX INPUT)
- ㉒ Ausgangsbuchsen für Tonband 1 (TAPE-1 REC)
- ㉓ Eingangsbuchsen für Tonband 1 (TAPE-1 PLAY)
- ㉔ Ausgangsbuchsen für Tonband 2 (TAPE-2 REC)
- ㉕ Eingangsbuchsen für Tonband 2 (TAPE-2 PLAY)
- ㉖ Lautsprecher-Auslußklemmen (SPEAKERS)
- ㉗ Kaltgerätestecker (3 für USA und Kanada, 1 für Asien und Lateinamerika)
- ㉘ Netzkabel
- ㉙ Sicherungshalter (FUSE) (für Asien und Lateinamerika)
- ㉚ Spannung-Wahlschalter (VOLTAGE SELECTOR) (für Asien und Lateinamerika)

- ① Interrupteur d'alimentation (POWER)
- ② Prise de casque d'écoute (PHONES)
- ③ Commutateurs d'enceintes (SPEAKERS)
- ④ Commande des tonalités graves (BASS)
- ⑤ Commande des tonalités aiguës (TREBLE)
- ⑥ Commande d'équilibrage (BALANCE)
- ⑦ Commutateur de tonalité (TONE)
- ⑧ Commutateur de filtre subsonique (SUBSONIC-FILTER)
- ⑨ Commutateur de correcteur physiologique (LOUDNESS)
- ⑩ Commutateur de copiage de bande (TAPE COPY)
- ⑪ Commutateur sélecteur de bande (TAPE SELECTOR)
- ⑫ Commutateur sélecteur de cellule (PHONO SELECTOR)
- ⑬ Commande de VOLUME
- ⑭ Témoins de source de programme
- ⑮ Commutateurs de fonction (FUNCTION)
- ⑯ Commutateur de contrôle de bande (TAPE MONITOR)
- ⑰ Témoins de puissance de crête
- ⑱ Borne de mise à la terre (GND)
- ⑲ Bornes d'entrée PU (PHONO INPUT)
- ⑳ Bornes d'entrée de tuner (TUNER INPUT)
- ㉑ Bornes d'entrée auxiliaire (AUX INPUT)
- ㉒ Bornes d'enregistrement sur magnétophone 1 (TAPE 1 REC)
- ㉓ Bornes de lecture de magnétophone 1 (TAPE 1 PLAY)
- ㉔ Bornes d'enregistrement sur magnétophone 2 (TAPE 2 REC)
- ㉕ Bornes de lecture de magnétophone 2 (TAPE 2 PLAY)
- ㉖ Bornes d'enceintes (SPEAKERS)
- ㉗ Prise de courant alternatif (3 prises pour appareils vendus aux Etats-Unis et au Canada, 1 prise pour les pays d'Asie et d'Amérique Latine)
- ㉘ Cordon d'alimentation en C.A.
- ㉙ Support de fusible (FUSE) (pour pays d'Asie et d'Amérique latine)
- ㉚ Sélecteur de tension (VOLTAGE SELECTOR) (pour pays d'Asie et d'Amérique Latine)

# CIRCUIT DIAGRAM · SCHALTPLAN · PLAN DE CIRCUIT (HA-4700)

**PRODUCT SAFETY NOTE:** Components marked with a  $\Delta$  have special characteristics important to safety.

**SICHERHEITSHINWEIS:** Die mit  $\Delta$  gekennzeichneten Komponenten haben wichtige Sicherheitsaufgaben.

**NOTICE DE SECURITE DE FABRICATION:** Les composants qui sont accompagnés du symbole  $\Delta$  possèdent des caractéristiques spéciales.

HA12017	
HA12002	
2SC2259	
2SC2546 2SC1775A 2SA872A 2SC1775 2SA872 2SC1740LN 2SB647A 2SD667A 2SC458 2SA844 2SB646	
2SA1075 2SC2525	
<b>PART NAME</b>	
2SD330AL 2SB514AL	
1S2473 1S2076A HZ-12-HZ-24	
ERB12-01R	
EQB01-10S	
MV-5	
CATHODE	
S5VB20	
GL-5PR6H GL-5NG6	
2SD668 2SB648	

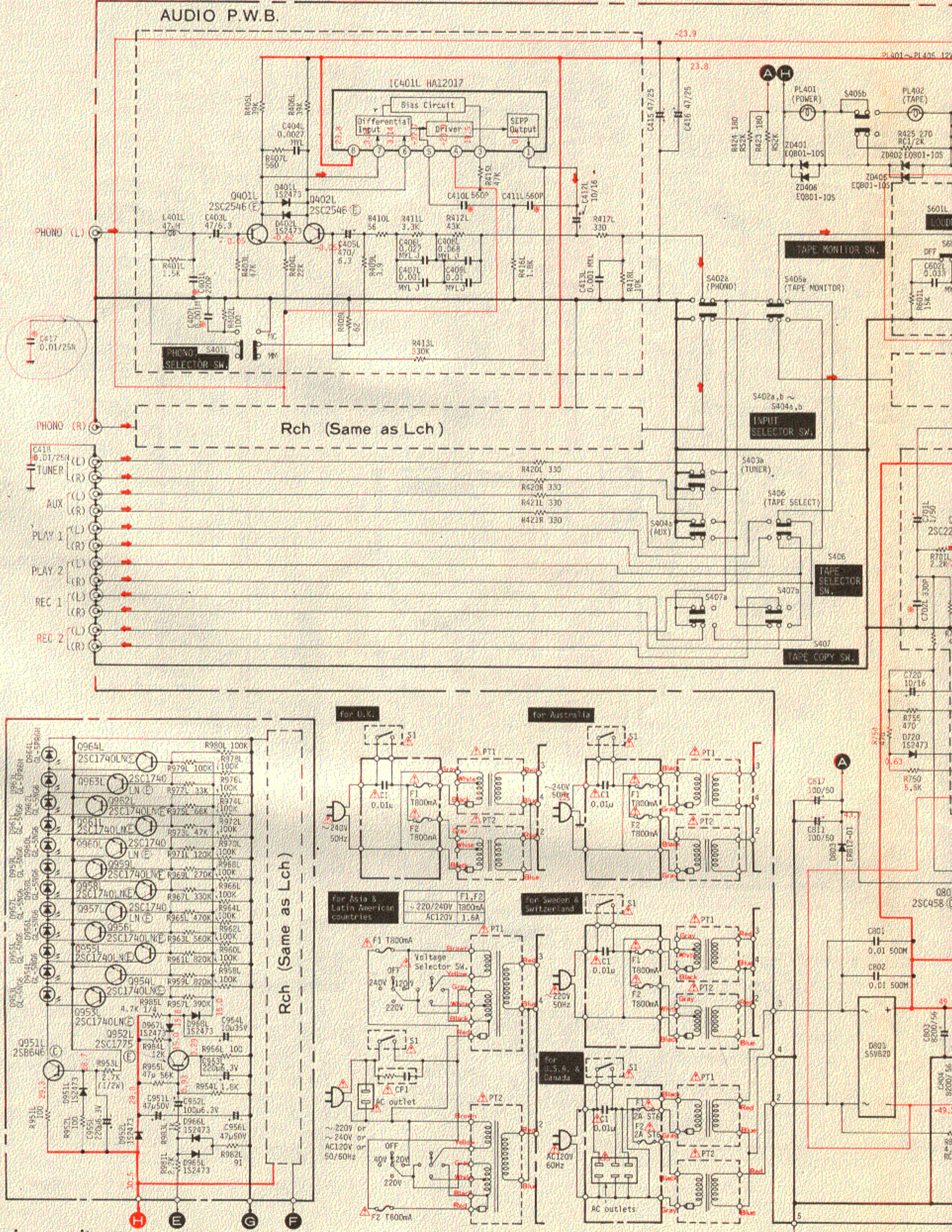

- \*: Axial lead cylindrical ceramic capacitor
- \*: Zylindrischer Keramikkondensator mit axialer Suleitung
- \*: Condensateur céramique cylindrique à conducteur axial

Fuse resistors are used to improve safety (to protect the circuit). When replacing them with new ones, be sure to use the designated type. Always use the designated fuse without fail.

**ZUR BEACHTUNG:** Schmelzwiderstände sind zur Erhöhung der Sicherheit vorgesehen (zum Schutz der Schaltung). Bei Austausch bitte nur die vorgeschriebene Type benutzen. Vergewissern Sie sich, daß die richtige Type gewählt ist.

**ATTENTINO:** Les résistance à fusible sont faites pour améliorer la sécurité de l'appareil (protection de circuit). Pour les remplacer, utiliser le même type. Utiliser toujours le modèle de fusible spécifié pour effectuer le remplacement.

éciales.

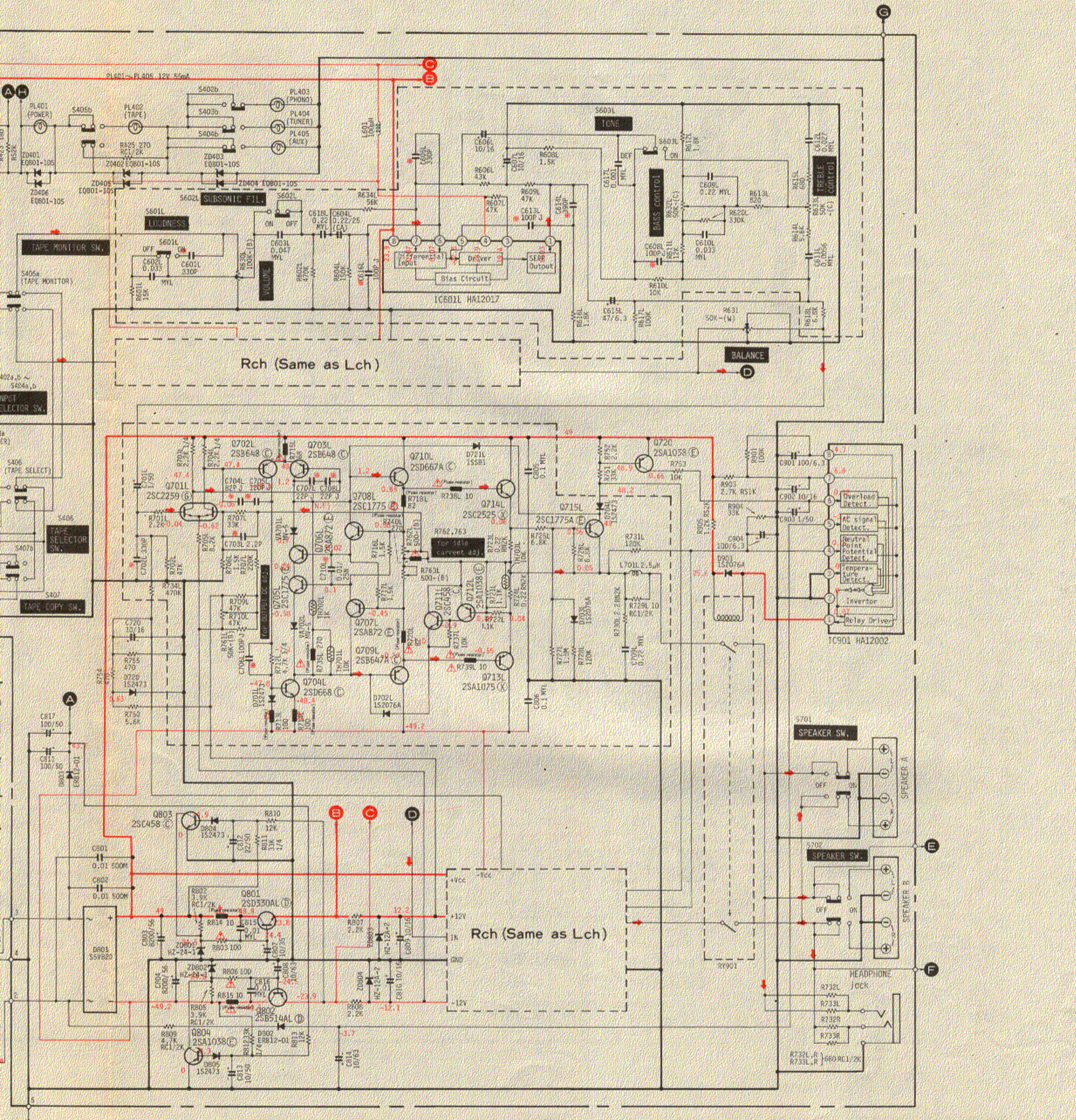

The circuit diagram is subject to change for improvement without notice.  
 Änderungen des Schaltplans im Sinne Ständiger Verbesserung vorbehalten.  
 Le schéma de montage est sujet à modification sans préavis, pour des raisons d'amélioration.

# ADJUSTMENT

## HA-4700

### (1) Idle current adjustment

Set the unit to no signal, speaker select switch OFF, volume control minimum, R762L set to 1 – 2 o'clock (R762R, to 10 – 11 o'clock) and R763L(R) to minimum (counterclockwise). Next, connect a DC voltmeter to R723L(R) and test point 22(23) and turn the power switch ON. After more than 10 minutes later, perform the following adjustment to both channels.

- ① Adjust R763L(R) so that the voltage is 7.7mV.
- ② Next, adjust R762L(R) so that the voltage is minimum ( $7.7\text{mV} \pm 2\text{mV}$ ).

When this is impossible, repeat Items ① and ②. (Fig.6)

### (2) Output DC adjustment

Perform this adjustment with no signal, volume control minimum, speaker select switch set to A or B and with no load. Connect a DC voltmeter between  $\oplus$  and  $\ominus$  L(R) output terminals of speaker A or B and adjust R761L(R) shown in Fig. 6 so that the output DC is 0 (within  $\pm 20\text{mV}$ ) measured in the 100mV range. This adjustment performs both channels.

(HA-4700)

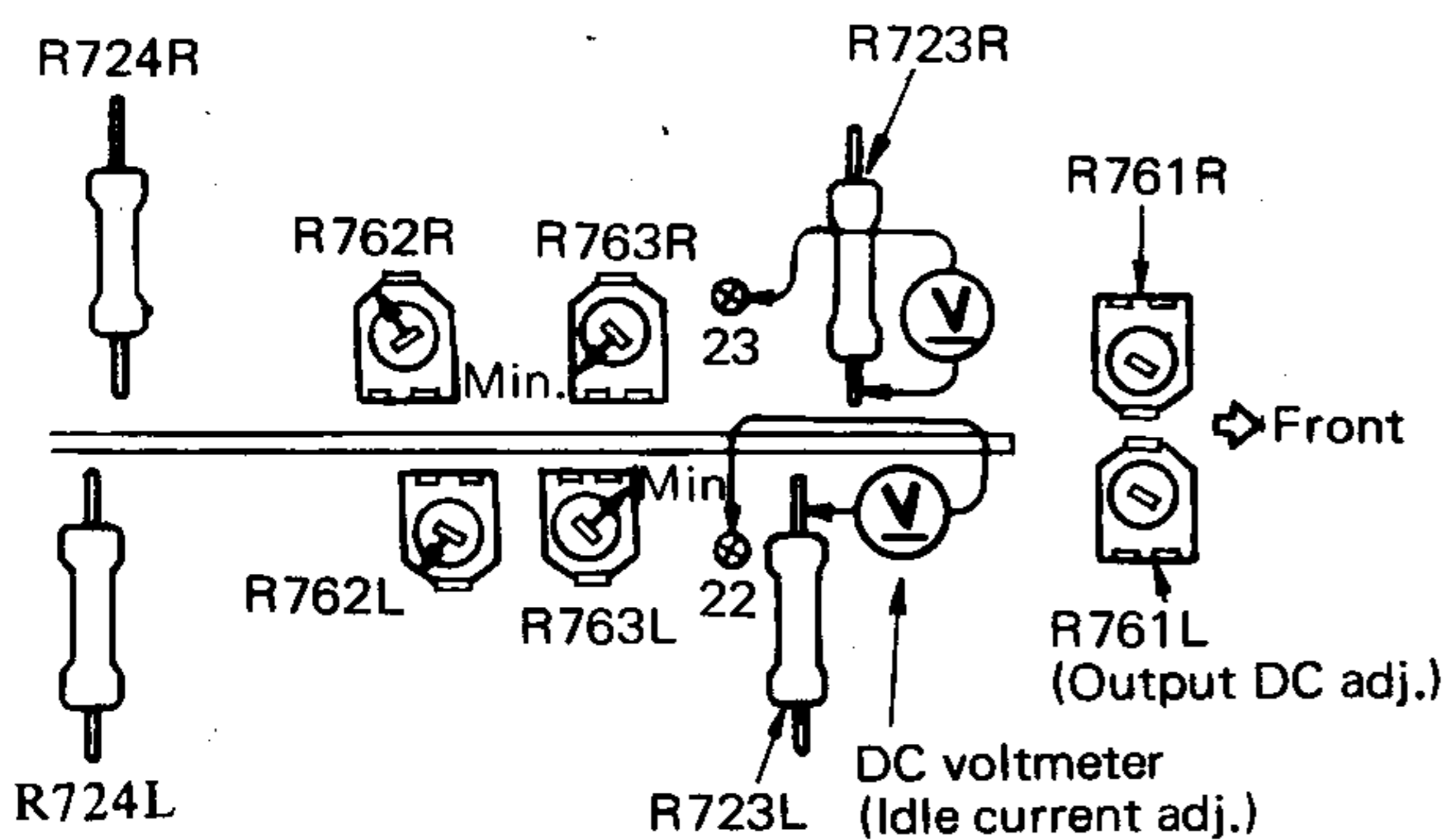

Fig. 6 Abb. 6

## HA-3700

### (1) Idle current adjustment

Set the unit to no signal, speaker select switch OFF, Volume control minimum, R750L to the 1 – 2 o'clock position (750R, to the 10 – 11 o'clock position) and R751L(R) to minimum (counterclockwise). Next, connect a DC voltmeter to R720L(R719R) and test point 20(19) and turn the power switch ON. After more than 10 minutes, perform the following adjustment to both channels.

- ① Adjust R751L(R) so that the voltage is 7.7mV.
- ② Next, adjust R750L(R) so that the voltage is minimum ( $7.7\text{mV} \pm 2\text{mV}$ ). When this is impossible, repeat items ① and ②. (Fig. 7)

### ● Checking the super linear circuit

When the balance adjustment becomes impossible (when  $R762 \leftarrow \text{HA4700}$  or  $R750 \leftarrow \text{HA-3700}$  is adjusted, the minimum point of current disappears and only increase or attenuation is possible) during the idle current adjustment, this indicates trouble in the super linear circuit transistors (Q705-708) so check it.

(HA-3700)

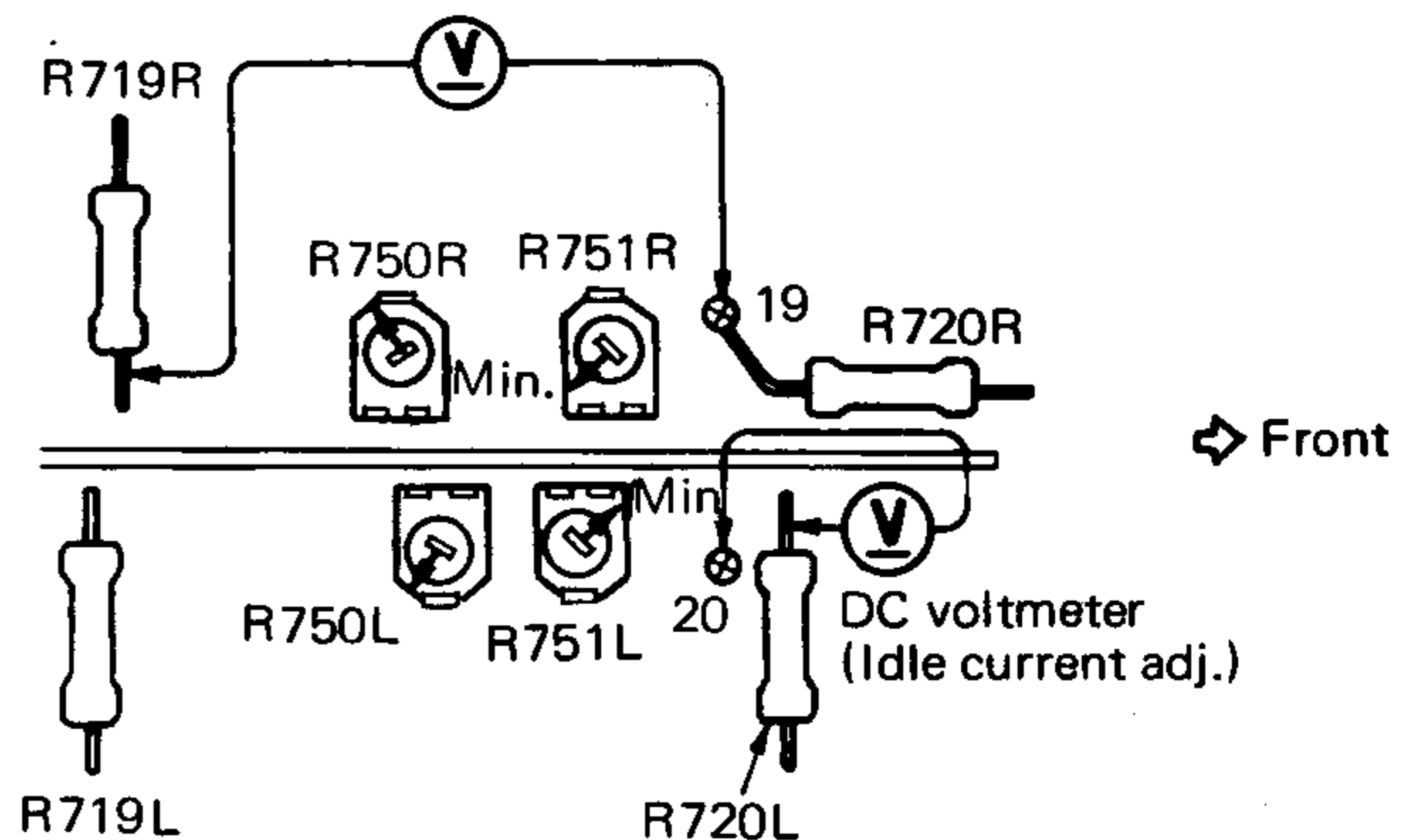

Fig. 7 Abb. 7

### ● Cautions on repairing and replacing parts

#### HA4700/3700

- (1) Be careful that the measuring instrument does not touch the parts around the part to be adjusted by mistake when adjusting the idle current, etc. Carefully adjust idle current, etc. using an adjusting screwdriver insulated with tape, etc.
- (2) Care has been taken in use of such parts as using fuse resistors, floating installation, etc. to improve safety. Be sure to use specified parts when replacing parts and install in the original condition.
- (3) If a measuring instrument with low impedance such as the tester is used when measuring the voltage of the first-stage transistors (Q701 – 703) of the main amp, it may cause oscillation or incorrect measurement. Use an electronic voltmeter with high input impedance.

#### HA-4700

- (1) The output DC adjustment may be changed when the parts of the stabilized power circuit or the main amp. are replaced. Be sure to check the output DC voltage.
- (2) Check Q803 and Q804 when the  $\pm B$  voltage is not present. This circuit operates to accelerate the decay characteristics to the stabilized power circuit of the  $\pm B$  power supply when the power is switched OFF.
- (3) 2 power transformers are used in this unit. When the thermal fuse of the power transformer or the primary fuse is blown, the bias of the transistors Q701 – 703 disappears and the amp. does not operate.

- Removing the printed wiring boards, power transistors
- Ausbau der Leiterplatten, Leistungstransistoren
- Déposer des plaquettes à circuit imprimé, transistors de puissance

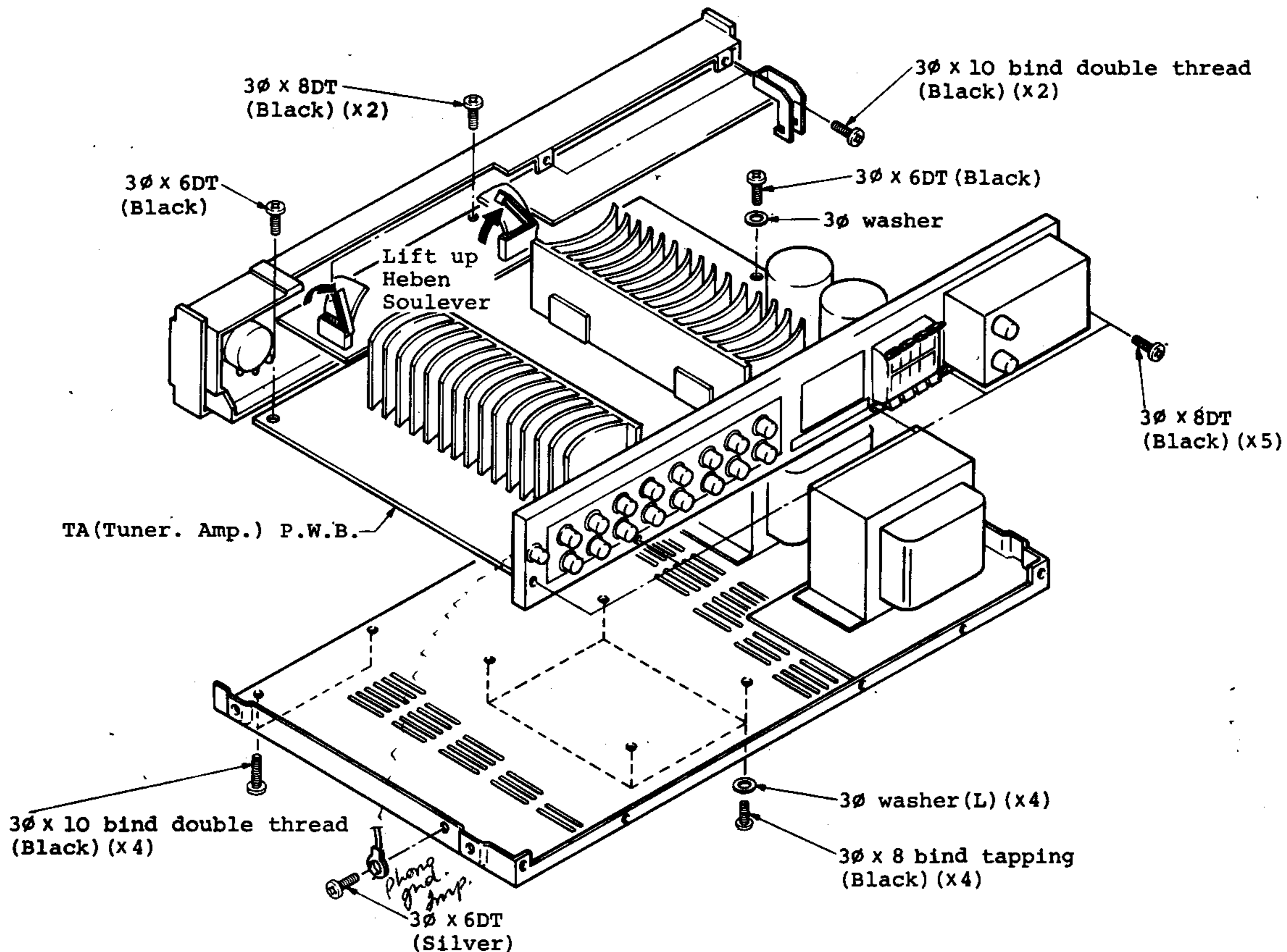

Fig. 3  
Abb. 3

Construction of Power bus

Assembled four pieces Bus line through the insulation sheets.

Vier Sammelleitungen durch Isolierfolien montiert.

Câbles électriques à quatre éléments assemblés à l'aide de plaquettes isolantes.

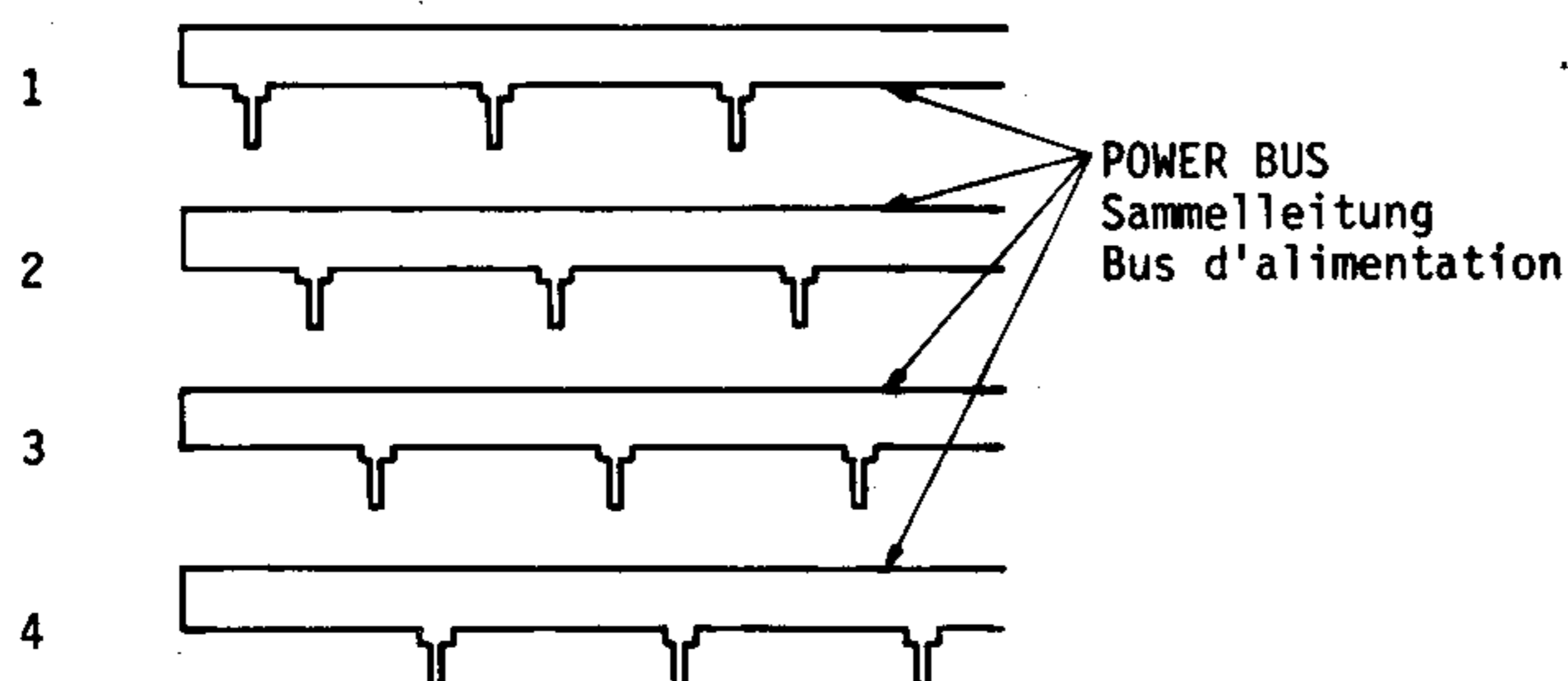

INSULATING SHEET  
Isolierfolie  
Plaquette isolante



BUS LINE  
Sammelleitung  
Câbles électriques

Fig. 4  
Abb.4

Method of exchange the S401 (HA-4700)

OPEN AND RELEASE THE WIRE  
Öffnen und Draht freigeben  
Ouvrir et relâcher le fil

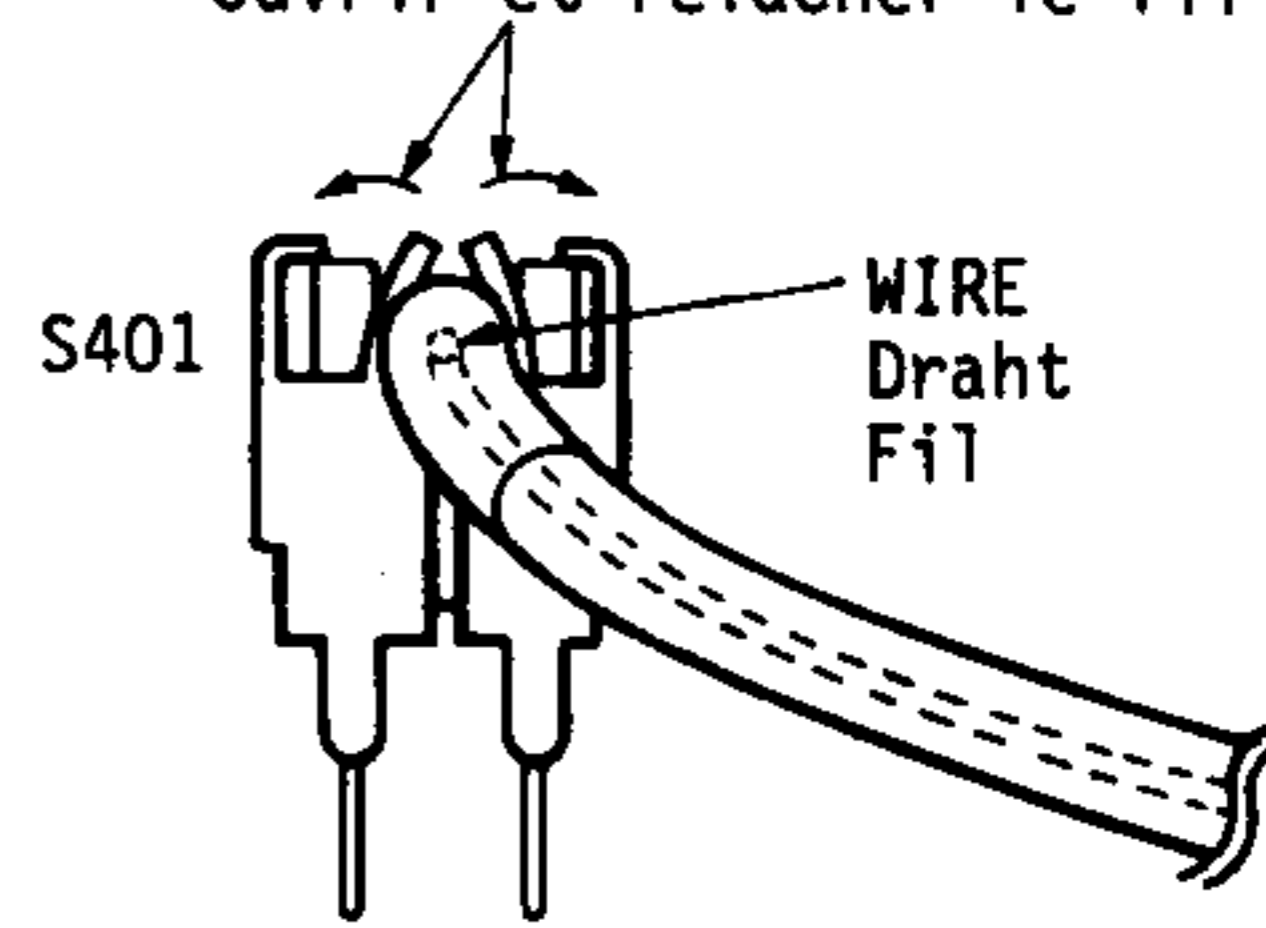

Fig. 5  
Abb.5

# HITACHI HA-4700/3700

## ● Caution on assembly

- (1) Be careful in layout during installation of the switch PW Board to the sub panel so that the 8-core jumper leads does not touch the input selector switch.
- (2) Install the PHONO selector switch to the sub panel

- before installing the switch PW Board.
- (3) Match the marking side (colored side) of the lead and mark ▼ stamped on the PW Board when installing the 7-core/8-core jumper leads to the jumper socket.

# DISASSEMBLY AND REPLACEMENT · ZERLEGUNG UND AUSTAUSCH DEMONTAGE ET REMONTAGE

- Removing the cover, escutcheon & bottom plate
- Ausbau der Abdeckung, der Schildanbringung und der Bodenplatte
- Déposer le couvercle, le cache-entrée et la plaque inférieure

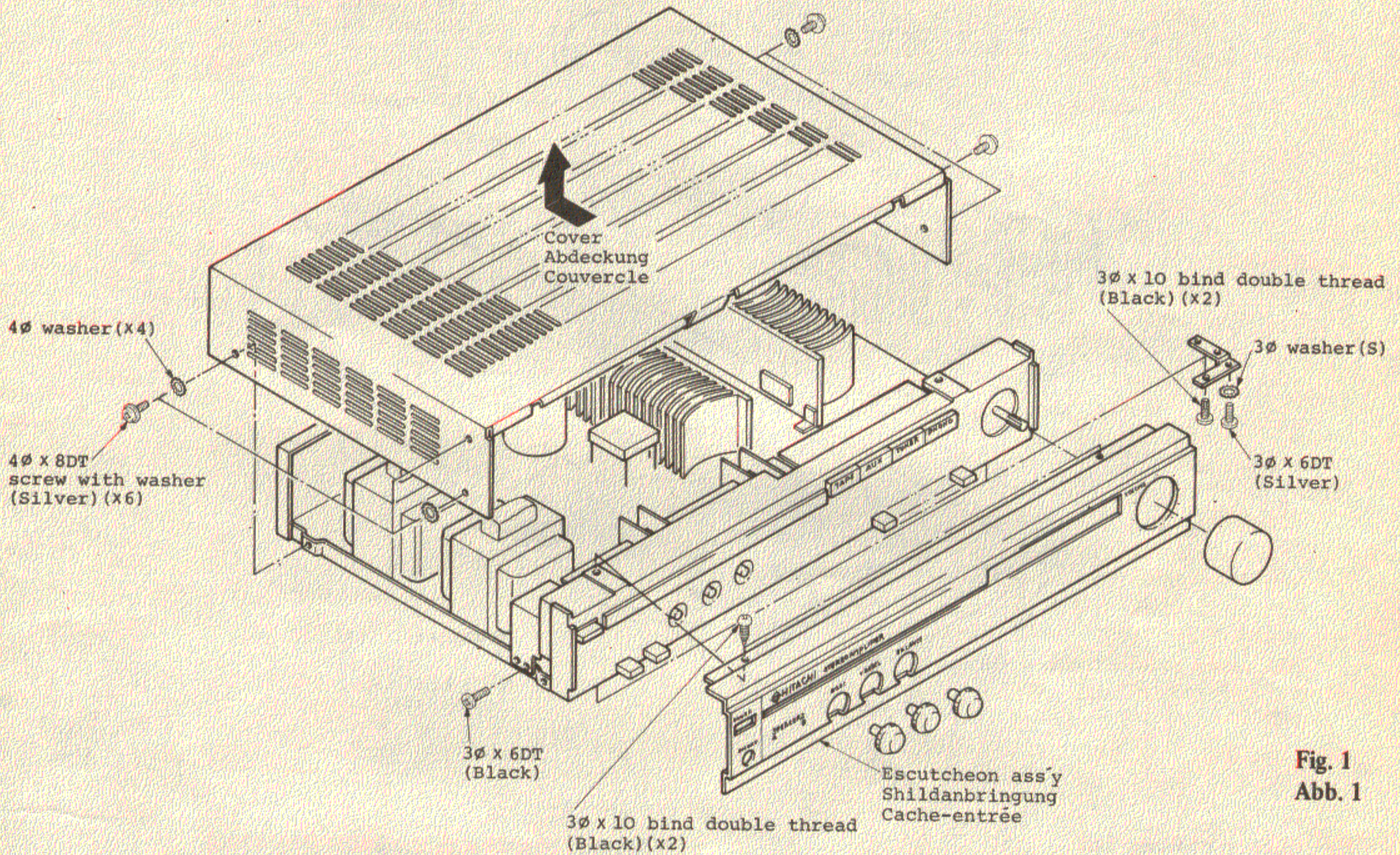

Fig. 1  
Abb. 1

- Removing the power transistor
- Ausbau der Leistungstransistoren
- Déposer les transistors de puissance

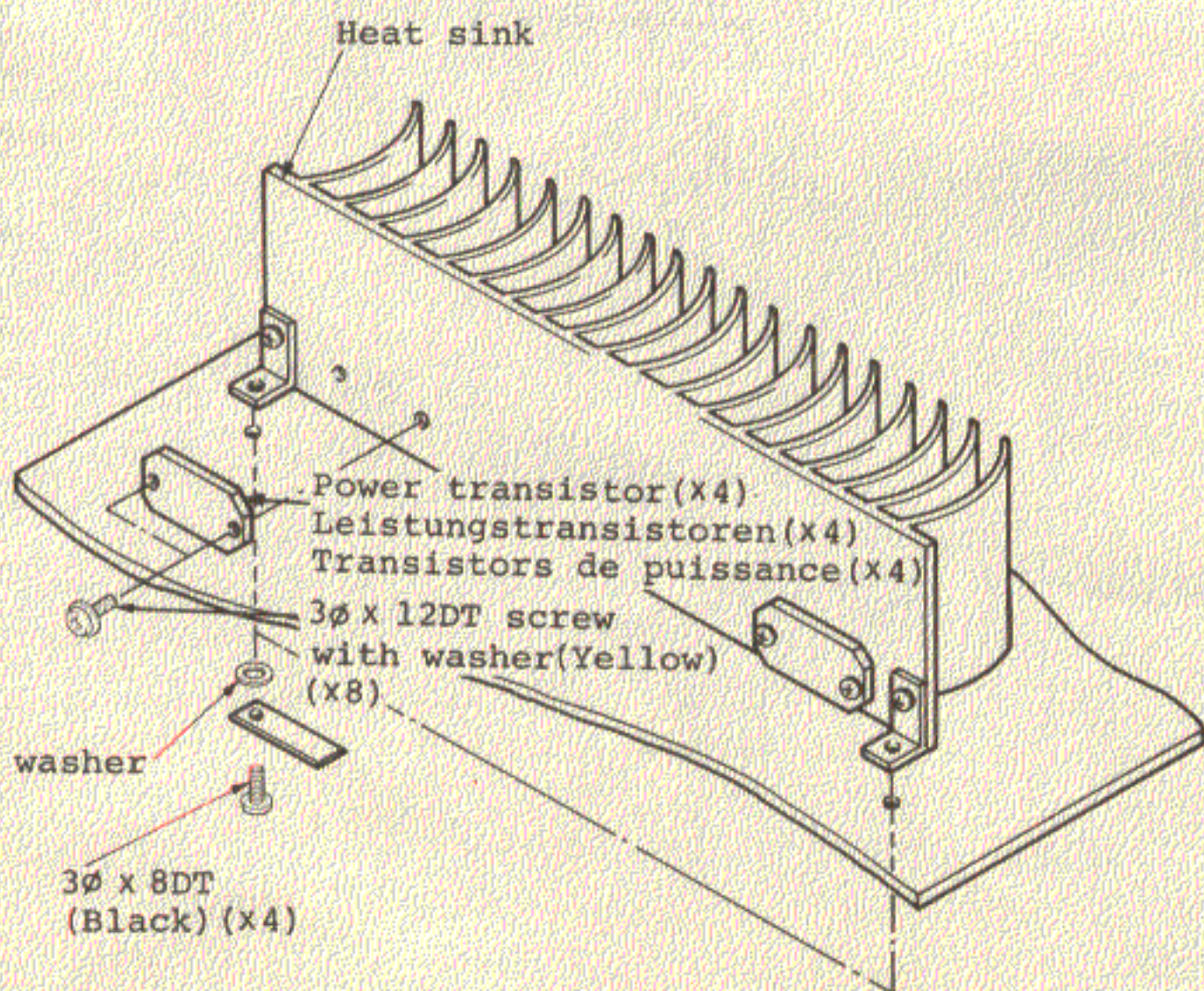

Fig. 2  
Abb. 2

**Caution**

Do not pull the Push knob (or Push connector) in the direction of the arrow (⇐) as it is directly connected to the Push switch.

**Warnung**

Druckknopf (oder Druckstecker) nicht in pfeilrichtung (⇐) ziehen, da dieser direkt mit dem Druckschalter verbunden ist.

**Attention**

Ne pas tirer le bouton-poussoir (ou le connecteur-poussoir) dans le sens indiqué par la flèche (⇐) étant donné qu'il est directement accouplé à l'interrupteur à poussoir.

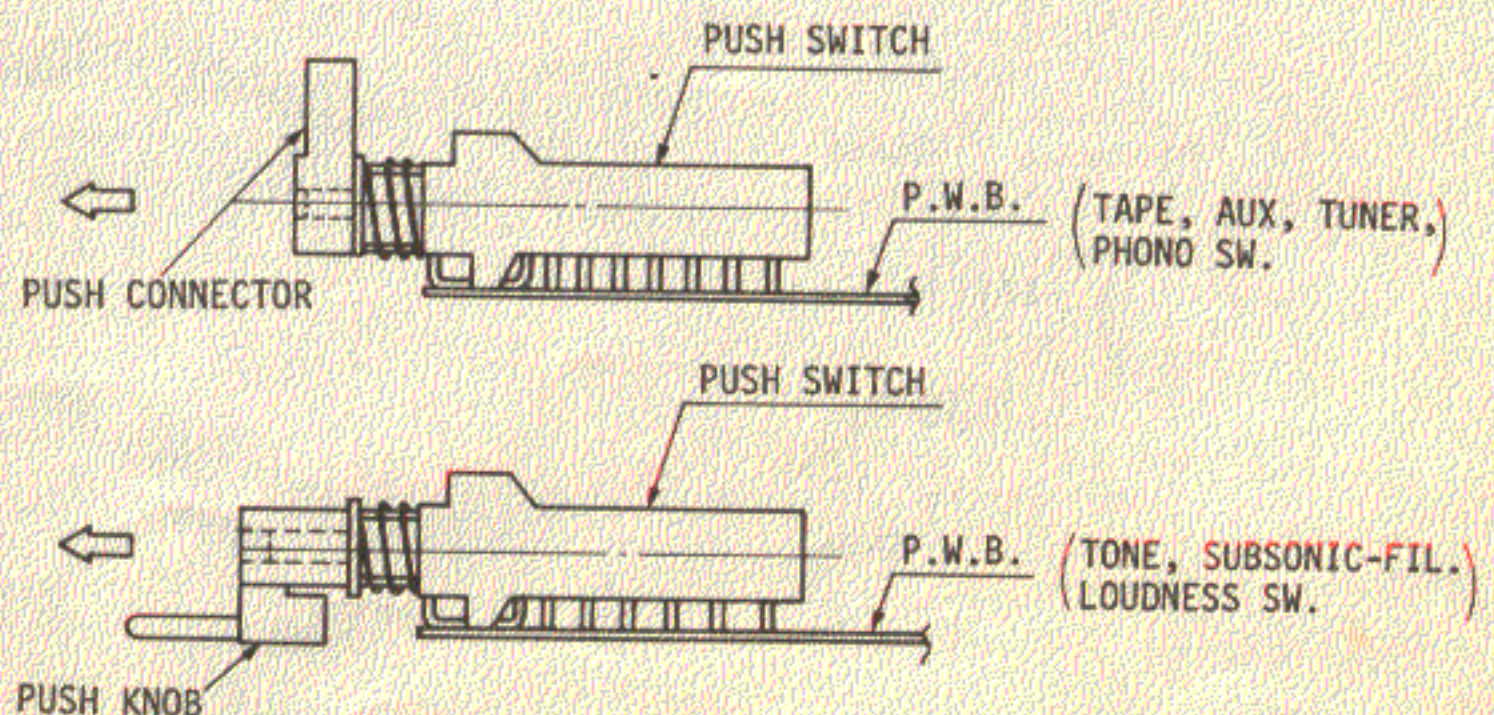

SYMBOL No.	STOCK No.	DESCRIPTION			SYMBOL No.	STOCK No.	DESCRIPTION			
R606L,R	0129646	Carbon film	43kΩ	±5%	SRD1/8P	R802	0134380	Composition	3.9kΩ ±10%	RC½GF
R607L,R	H129647	Carbon film	47kΩ	±5%	SRD1/8P	△ R803	0100661	Carbon film	100Ω ±5%	SRD¼P
R608L,R	H129605	Carbon film	1.5kΩ	±5%	SRD1/8P	R805	0134380	Ceramic, discal	3.9kΩ ±5%	RC½GF
R609L,R	H129647	Carbon film	47kΩ	±5%	SRD1/8P	△ R806	0100661	Carbon film	100Ω ±5%	SRD¼P
R610L,R	H129631	Carbon film	10kΩ	±5%	SRD1/8P	R807	H129609	Carbon film	2.2kΩ ±5%	SRD1/8P
R611L,R	H129633	Carbon film	12kΩ	±5%	SRD1/8P	R808	H129609	Carbon film	2.2kΩ ±5%	SRD1/8P
R612L	H129607	Carbon film	1.8kΩ	±5%	SRD1/8P	R809	0134381	Composition	4.7kΩ ±10%	RC½GF
R612R	0129607	Carbon film	1.8kΩ	±5%	SRD1/8P	R810	H129633	Carbon film	12kΩ ±5%	SRD1/8P
R613L,R	H129583	Carbon film	820Ω	±5%	SRD1/8P	R811	0114213	Carbon film	33kΩ ±5%	SRD¼P
R614L,R	H129619	Carbon film	5.6kΩ	±5%	SRD1/8P	R812	0114213	Carbon film	33kΩ ±5%	SRD¼P
R615L,R	H129581	Carbon film	680Ω	±5%	SRD1/8P	R813	H129633	Carbon film	12kΩ ±5%	SRD1/8P
R616L,R	H129607	Carbon film	1.8kΩ	±5%	SRD1/8P	△ R814	0110601	Metal (fuse resistor)	10Ω ±5%	RN¼B
R617L,R	H129661	Carbon film	100kΩ	±5%	SRD1/8P	△ R815	0110601	Metal (fuse resistor)	10Ω ±5%	RN¼B
R618L,R	H129621	Carbon film	6.8kΩ	±5%	SRD1/8P	R901	H129661	Carbon film	100kΩ ±5%	SRD1/8P
R620L,R	H129673	Carbon film	330kΩ	±5%	SRD1/8P	R903	0119446	Metal, oxide	2.7kΩ ±10%	RS1B
R634L,R	0129649	Carbon film	56kΩ	±5%	SRD1/8P	R904	H129643	Carbon film	33kΩ ±5%	SRD1/8P
R701L,R	H129609	Carbon film	2.2kΩ	±5%	SRD1/8P	R905	0119542	Metal, oxide	1.2kΩ ±10%	RS2B
R702L,R	H129647	Carbon film	47kΩ	±5%	SRD1/8P	R951L	0138081	Carbon film	100Ω ±5%	SRD¼SD
R703L,R	0138129	Carbon film	2.2kΩ	±5%	SRD¼SD	R951R	H129561	Carbon film	100Ω ±5%	SRD1/8P
R704L,R	0138129	Carbon film	2.2kΩ	±5%	SRD¼SD	R952L	0138081	Carbon film	100Ω ±5%	SRD¼SD
R705L,R	H129623	Carbon film	8.2kΩ	±5%	SRD1/8P	R952R	H129561	Carbon film	100Ω ±5%	SRD1/8P
R706L,R	H129605	Carbon film	1.5kΩ	±5%	SRD1/8P	R953L,R	0134378	Composition	2.7kΩ ±10%	RC½GF
R707L,R	H129643	Carbon film	33kΩ	±5%	SRD1/8P	R954L,R	H129607	Carbon film	1.8kΩ ±5%	SRD1/8P
R708L,R	H129669	Carbon film	220kΩ	±5%	SRD1/8P	R955L,R	0138179	Carbon film	56kΩ ±5%	SRD¼P
R709L,R	H129647	Carbon film	47kΩ	±5%	SRD1/8P	R956L,R	H129561	Carbon film	100Ω ±5%	SRD1/8P
R710L,R	H129647	Carbon film	47kΩ	±5%	SRD1/8P	R957L,R	H129675	Carbon film	390kΩ ±5%	SRD1/8P
R712L,R	0114177	Carbon film	4.7kΩ	±5%	SRD¼P	R958L,R	H129661	Carbon film	100kΩ ±5%	SRD1/8P
△ R713L,R	0110621	Metal (fuse resistor)	100Ω	±5%	RN¼B	R959L,R	H129683	Carbon film	820kΩ ±5%	SRD1/8P
△ R714L,R	0110621	Metal (fuse resistor)	100Ω	±5%	RN¼B	R960L,R	H129661	Carbon film	100kΩ ±5%	SRD1/8P
△ R715L,R	0110611	Metal (fuse resistor)	68Ω	±5%	RN¼B	R961L,R	H129683	Carbon film	820kΩ ±5%	SRD1/8P
R716L,R	H129605	Carbon film	1.5kΩ	±5%	SRD1/8P	R962L,R	H129661	Carbon film	100kΩ ±5%	SRD1/8P
R717L,R	H129605	Carbon film	1.5kΩ	±5%	SRD1/8P	R963L,R	H129679	Carbon film	560kΩ ±5%	SRD1/8P
△ R718L,R	0110612	Metal (fuse resistor)	82Ω	±5%	RN¼B	R964L,R	H129661	Carbon film	100kΩ ±5%	SRD1/8P
△ R720L,R	0110612	Metal (fuse resistor)	82Ω	±5%	RN¼B	R965L,R	H129677	Carbon film	470kΩ ±5%	SRD1/8P
R721L,R	0129602	Carbon film	1.1kΩ	±5%	SRD1/8P	R966L,R	H129661	Carbon film	100kΩ ±5%	SRD1/8P
R722L,R	H129605	Carbon film	1.5kΩ	±5%	SRD1/8P	R967L,R	H129673	Carbon film	330kΩ ±5%	SRD1/8P
R722L,R	0129602	Carbon film	1.1kΩ	±5%	SRD1/8P	R968L,R	H129661	Carbon film	100kΩ ±5%	SRD1/8P
R723L,R	0119123	Metal	0.22Ω	±10%	RN2B	R969L,R	H129671	Carbon film	270kΩ ±5%	SRD1/8P
R724L,R	0119123	Metal	0.22Ω	±10%	RN2B	R970L,R	H129661	Carbon film	100kΩ ±5%	SRD1/8P
R725L,R	H129621	Carbon film	6.8kΩ	±5%	SRD1/8P	R971L,R	H129663	Carbon film	120kΩ ±5%	SRD1/8P
R726L,R	H129621	Carbon film	6.8kΩ	±5%	SRD1/8P	R972L,R	H129661	Carbon film	100kΩ ±5%	SRD1/8P
R727L,R	H129705	Carbon film	1.5MΩ	±5%	SRD1/8P	R973L,R	H129647	Carbon film	47kΩ ±5%	SRD1/8P
R728L,R	H129663	Carbon film	120kΩ	±5%	SRD1/8P	R974L,R	H129661	Carbon film	100kΩ ±5%	SRD1/8P
R729L,R	0134289	Composition	10Ω	±10%	RC½GF	R975L,R	H129651	Carbon film	68kΩ ±5%	SRD1/8P
R730L,R	0119135	Metal	2.2Ω	±10%	RN2B	R976L,R	H129661	Carbon film	100kΩ ±5%	SRD1/8P
R731L,R	H129663	Carbon film	120kΩ	±5%	SRD1/8P	R977L,R	H129641	Carbon film	33kΩ ±5%	SRD1/8P
R732L,R	0134369	Composition	470Ω	±10%	RC½GF	R978L,R	H129661	Carbon film	100kΩ ±5%	SRD1/8P
R733L,R	0134369	Composition	470Ω	±10%	RC½GF	R979L,R	H129661	Carbon film	100kΩ ±5%	SRD1/8P
R734L,R	H129677	Carbon film	470kΩ	±5%	SRD1/8P	R980L,R	H129661	Carbon film	100kΩ ±5%	SRD1/8P
△ R735L,R	0110627	Metal (fuse resistor)	330Ω	±5%	RN¼B	R981L,R	H129609	Carbon film	2.2kΩ ±5%	SRD1/8P
R737L,R	H129631	Carbon film	10kΩ	±5%	SRD1/8P	R982L,R	0129554	Carbon film	91Ω ±5%	SRD1/8P
△ R738L,R	0110601	Metal (fuse resistor)	10Ω	±5%	RN¼B	R983L,R	H129601	Carbon film	1kΩ ±5%	SRD1/8P
△ R739L,R	0110601	Metal (fuse resistor)	10Ω	±5%	RN¼B	R984L,R	H129633	Carbon film	12kΩ ±5%	SRD1/8P
△ R740L,R	0110621	Metal (fuse resistor)	270Ω	±5%	RN¼B	R985L,R	0138137	Carbon film	4.7kΩ ±5%	SRD1/8P
R750	H129619	Carbon film	5.6kΩ	±5%	SRD1/8P	<b>ICs &amp; TRANSISTORS</b>				
R751	H129643	Carbon film	33kΩ	±5%	SRD1/8P	IC401L,R	2367871	HA12017		
R752	H129609	Carbon film	2.2kΩ	±5%	SRD1/8P	IC601L,R	2367871	HA12017		
R753	H129631	Carbon film	10kΩ	±5%	SRD1/8P	IC901	2367372	HA12002 (Red)		
R754	H129577	Carbon film	470Ω	±5%	SRD1/8P					
R755	H129577	Carbon film	470Ω	±5%	SRD1/8P					



SYMBOL No.	STOCK No.	DESCRIPTION	SYMBOL No.	STOCK No.	DESCRIPTION
Q402L,R	2329152	2SC2546 (E)			
Q402L,R	2329152	2SC2546 (E)			
Q701L,R	2367654	2SC2559 (G)	ZD801	2337187	HZ-24-1
Q702L,R	2328842	2SB648 (C)	ZD802	2337187	HZ-24-1
Q703L,R	2328742	2SB648 (C)	ZD803	2337562	HZ-12A-2
Q704L,R	2328852	2SD668 (C)	ZD804	2337562	HZ-12A-2
Q705L,R	2327913	2SC1775 (E)	TH701L,R	2347114	Thermistor (10kΩ)
Q706L,R	2327893	2SA872 (E)	TH702L,R	2347113	Thermistor (1kΩ)
Q707L,R	2327893	2SA872 (E)	TH703L,R	2347114	Thermistor (10kΩ)
Q708L,R	2327913	2SC1775 (E)	TH951L,R	2347114	Thermistor (10kΩ)
Q709L,R	2328622	2SB647A (C)	VA701L,R	2347041	MV-5
Q710L,R	2328632	2SD667A (C)	VA702L,R	2347041	MV-5
Q711L,R	2328282	2SC458 (C)	<b>VARIABLE RESISTORS</b>		
Q712L,R	2328773	2SA1038 (E)	R630L,R	0156157	100kΩ-(B) (VOLUME)
Q713L,R	2329171	2SA1075 (X)	R631	0151847	50kΩ-(W) (BALANCE)
Q714L,R	2329161	2SC2525 (X)	R632L,R	0151806	50kΩ-(C) (BASS)
Q715L,R	2327923	2SC1775A (E)	R633L,R	0151806	50kΩ-(C) (TREBLE)
Q720	2328773	2SA1038 (E)	R761L,R	0151334	50kΩ-(B) (for DC current adj.)
Q721L,R	2337641	1SS81	R762L,R	0151339	500Ω-(B) (for idle current adj.)
Q801	2328972	2SD330AL (D)	R763L,R	0151339	500Ω-(B) (for idle current adj.)
Q802	2328962	2SB514AL (D)	<b>COILS</b>		
Q803	2328282	2SC458 (C)	L401L,R	2227371	Choke coil-47μH
Q804	2328773	2SA1038 (E)	L601	2227322	Choke coil-100μH
Q951L,R	2328452	2SB646 (C)	L701L,R	2227311	Audio trap coil-2.5μH
Q952L,R	2327913	2SC1775 (E)	<b>MISCELLANEOUS</b>		
Q953L,R	2328653	2SC1740LN (E)		2688111	Power bus
Q964L,R	2328653	2SC1740LN (E)		2657705	Jumper socket (7P)
<b>DIODES &amp; THERMISTORS</b>				2657706	Jumper socket (8P)
D401L,R	2337601	1S2473		4790098	Fiber washer
D402L,R	2337601	1S2473		2677395	6P US pin jack
D701L,R	2337601	1S2473		2677392	4P US pin jack
D702L,R	2337151	1S2076A		2677591	Jack-headphone jack
D703L,R	2337151	1S2076A		2688121	Speaker terminal (8P)
D704L,R	2337601	1S2473	S401	2627451	Switch-push switch (MM/MC)
D720	2337601	1S2473	S402-405	2638661	Switch-push switch (for input selector, tape moni.)
D801	2337341	S5VB20	S406,407 601-603	2638671	Switch-push switch
D802	2337761	ERB12-01	S701,702	2638622	Switch-push switch (for speaker selector) (for U.S.A. & Canada)
D803	2337761	ERB12-01	S701,702	2638621	Switch-push switch (for speaker selector) (except U.S.A. & Canada)
D804	2337601	1S2473	△ S1	2638601	Switch-Power switch (for U.S.A. & Canada)
D805	2337601	1S2473	△ S1	2638221	Switch-Power switch (except U.S.A. & Canada)
D901	2337151	1S2076A	RY901	2647221	Power relay
D951L,R	2337601	1S2473		8812114	3 φ washer
D952L,R	2337601	1S2473		4567432	3 φ × 8DT bind screw (Black)
D953L,R	2337812	LED (GL-5NG6) (Green)		4572312	3 φ × 12 bind tapping screw
D962L,R	2337812	LED (GL-5NG6) (Green)	PL402	2767581	} Meter lamp (for PHONO, TUNER, AUX & TAPE indi.)
D963L,R	2337752	LED (GL-5NG6H) (Red)	PL403	2767581	
D964L,R	2337752	LED (GL-5NG6H) (Red)	PL404	2767581	
D965L,R	2337601	1S2473	PL405	2767581	
D966L,R	2337601	1S2473			
D967L,R	2337601	1S2473			
D968L,R	2337601	1S2473			
ZD401	2337778	EQB01-10S			
ZD406	2337778	EQB01-10S			

● **Circuit d'ampli égaliseur** (Fig. 12)

Ce circuit se compose d'un transistor faible bruit (2SC2546) et d'un circuit intégré faible bruit (HA 12017) et ces deux composants sont combinés de sorte que la cellule à bobine mobile puisse être directement connectée. En procédant ainsi, une haute sensibilité (sensibilité d'entrée: 0,15mV) un rapport signal sur bruit élevé (90 dB avec les cellules à aimant mobile et 73 dB avec les cellules à bobine mobile [converti en entrée de 0,25mV] sont obtenus.

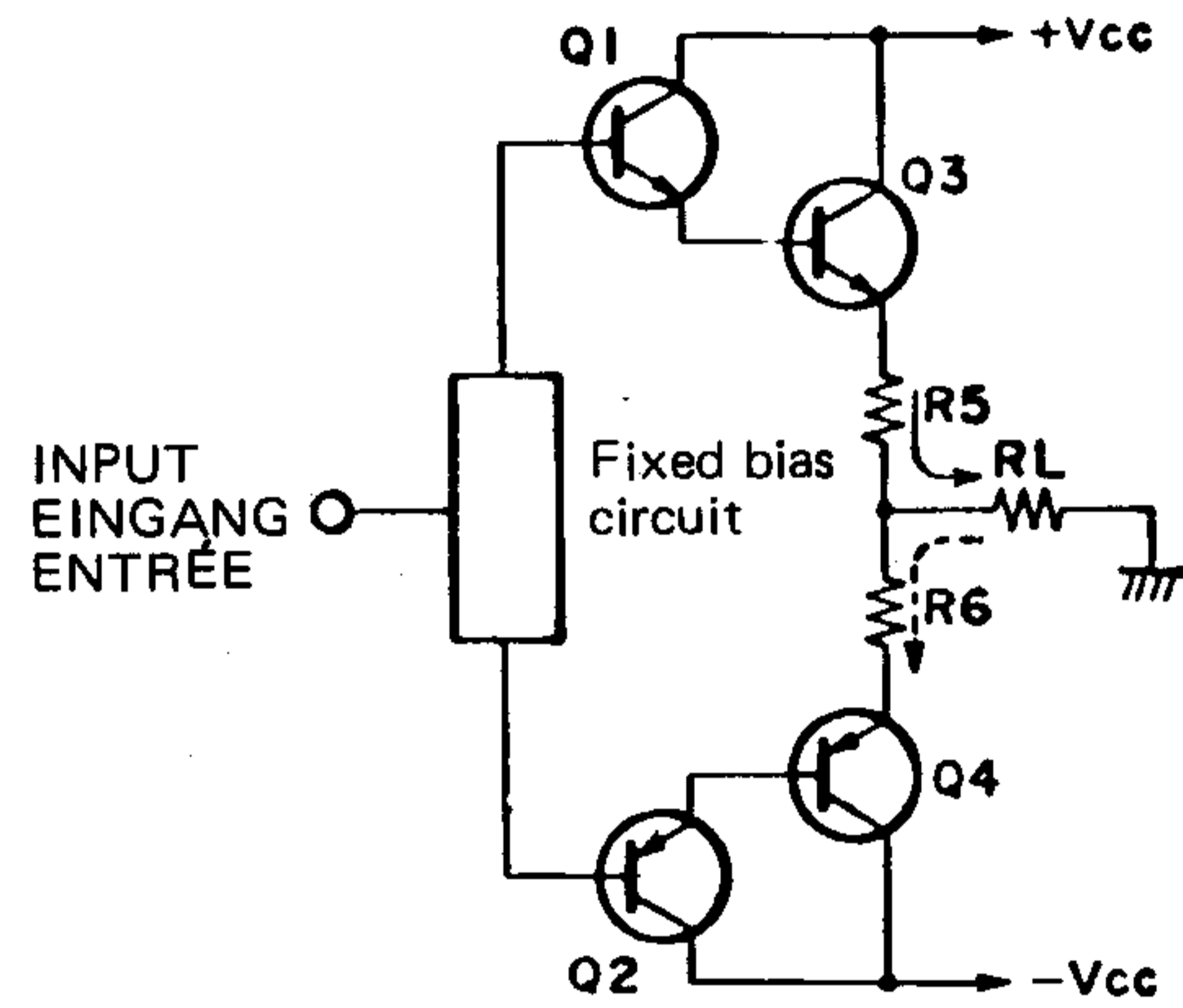

Fig. 8  
Abb. 8

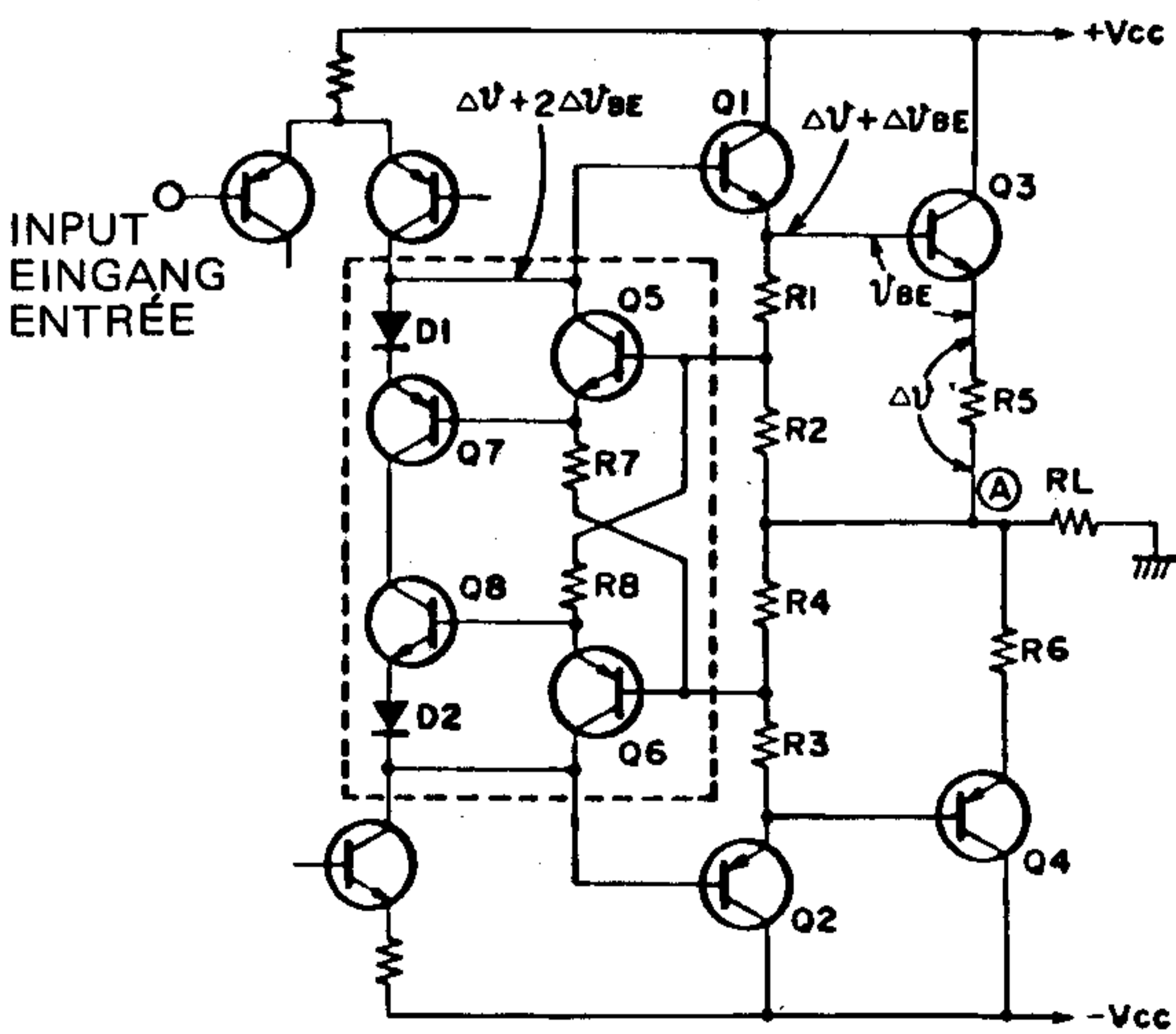
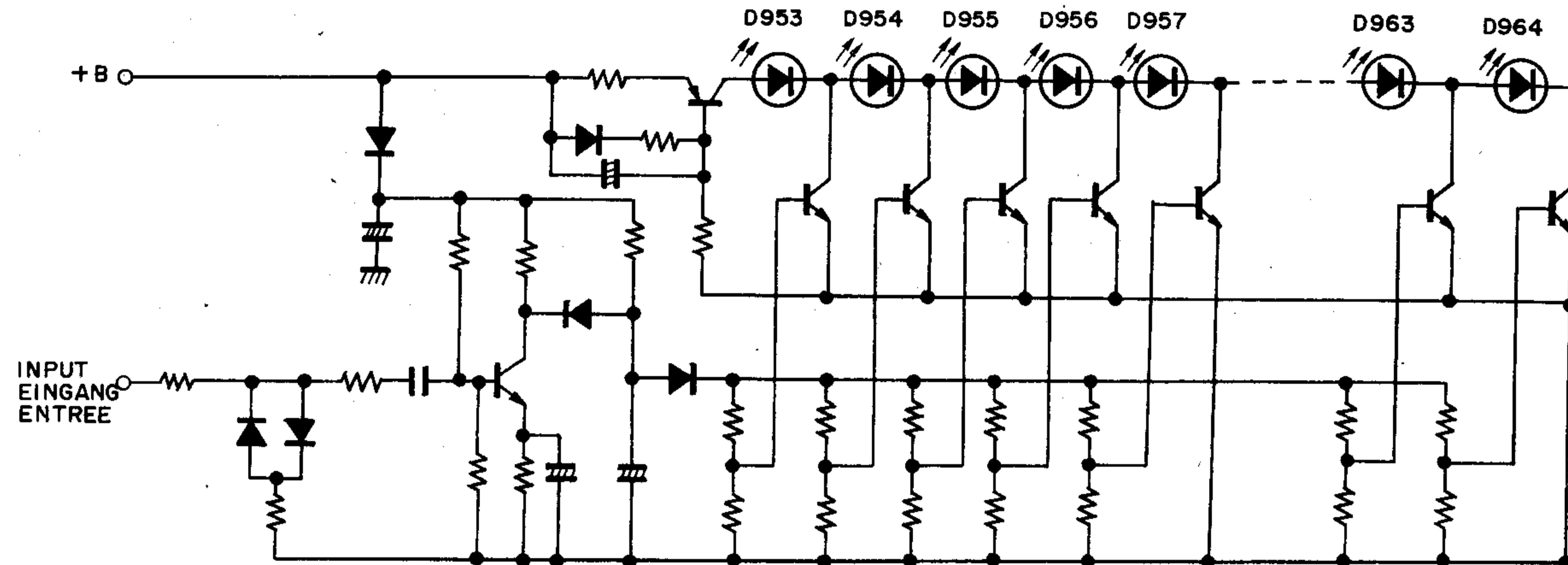

Fig. 9  
Abb. 9

0.04	●	○	○	○	○	○	○	○	○	○	○	○	○	○
0.01	●	○	○	○	○	○	○	○	○	○	○	○	○	○
POWER OUTPUT	D953	D954	D955	D956	D957	D958	D959	D960	D961	D962	D963	D964		
LED														

(HA-4700)

Fig. 10  
Abb. 10



(HA-4700)

Fig. 11  
Abb. 11

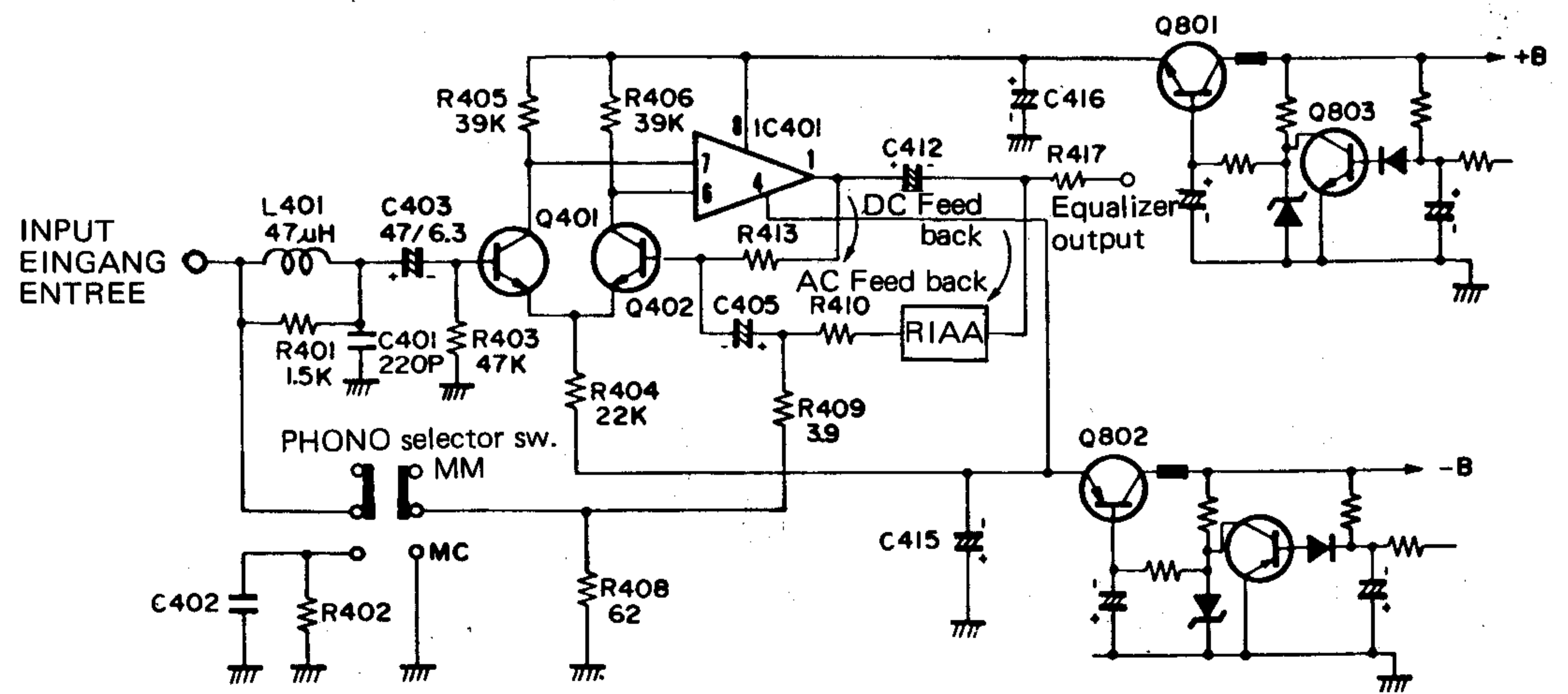

This figure shows HA-4700.

Fig. 12  
Abb. 12

DESCRIPTION OF THE NEW CIRCUIT · BESCHREIBUNG DES NEUEN SCHALTKREISES · RENSEIGNEMENTS CONCERNANT LE NOUVEAU CIRCUIT

HA-4700/3700

• Super linear circuit

The class B amplifier circuit is constructed as shown in Fig. 8. A constant idle current flows from the fixed bias circuit, Q3 and Q4 are alternately switched ON/OFF corresponding to the input signal, and current flows to Load  $R_L$ . However, with this transistor, the response of the output current is delayed with respect to the base input current due to the time of the carrier storage at the base when this transistor changed from OFF to ON. As a result, it causes generation of switching distortion when the transistor changes from OFF to ON; the frequency increases as the signal frequency is higher. So, a circuit which varies the conventionally fixed bias voltage according to the signal strength applies a constant bias voltage when there is no signal to prevent Q3 and Q4 from being set to OFF and prevent the generation of switching distortion has been installed. The circuit surrounded by broken lines in Fig. 9 shows this bias circuit; this is called the super linear circuit. In Fig. 9, the output neutral point (A) with non signal is assumed to be the reference. When a positive signal is input, positive current flows to the load resistor  $R_L$ .

Voltage drop  $\Delta v$  occurs in  $R_5$  and  $\Delta v_{BE}$  in Q3 by means of this current, the emitter (Base of Q3) voltage of Q1 becomes higher by  $\Delta v + \Delta v_{BE}$  compared with that during no signal and the base bias of Q5 becomes higher. When the base bias of Q5 becomes higher, the current increases, the voltage across  $R_7$  becomes higher, and the bias voltage of Q6 does not change compared with that of point (A). Accordingly, the base voltage of Q2 which is biased by Q6, Q8 and D2 is kept approximately the same as that during no signal, and the idle current continues to flow.

In the case of a negative signal, the reverse operation is performed keeping the base bias of Q1 constant. In the actual circuit, variable resistors are used for  $R_2$ ,  $R_4$  to adjust idle current, and in addition, a circuit which performs thermal compensation is installed.

• LED power meter drive circuit

12 LEDs (HA-3700 7LEDs) per channel are used to indicate output level. These LEDs are driven by meter circuit; the relationship between the output level and the number of LEDs lit when  $8\Omega$  speakers are connected is as shown in Fig. 10. Incidentally, Fig. 11 shows the operation circuit.

HA-4700

• Equalizer amp. circuit (Fig. 12)

This circuit is composed of a low noise transistor (2SC2546) and low noise IC (HA12017) combined, to directly connect an MC cartridge. By this, high sensitivity (input sensitivity: 0.15mV), high S/N ratio (90dB with an MM cartridge, 73dB with an MC cartridge [converted to 0.25mV input]) are obtained.

HA-4700/3700

• Super-linearer Vorspannungs-Schaltkreis

Der Schaltkreis des Verstärkers der Betriebsklasse B ist in Abb. 8 dargestellt. Ein konstanter Ruhestrom fließt vom Schaltkreis für feste Vorspannung, so daß in Abhängigkeit vom Eingangssignal die Transistoren Q3 und Q4 abwechselnd leitend werden und sperren und ein Strom zur Last  $R_L$  fließt. Aufgrund der Zeitkonstanten des Transistors wird dabei jedoch der Ausgangsstrom gegenüber dem Basis-Eingangsstrom verzögert, wenn der Transistor vom sperrenden in den leitenden Zustand übergeht. Es entstehen daher Schaltverzerrungen, die besonders bei den hohen Frequenzanteilen zunehmen. Es wurde daher ein Schaltkreis entwickelt, der eine Vorspannung auch dann anlegt, wenn kein Signal vorhanden ist. Dadurch werden die Transistoren Q3 und Q4 immer im leitenden Zustand gehalten, so daß es zu keinen Schaltverzerrungen kommen kann. Dieser Schaltkreis ist in Abb. 9 durch eine gestrichelte Linie umrandet und wird super-linearer Vorspannungs-Schaltkreis genannt.

In Abb. 9 wird der Punkt (A) ohne Signal als Bezugspunkt angenommen. Wenn nun ein positives Signal eingespeist wird, fließt ein positiver Strom zum Lastwiderstand  $R_L$ .

Es entsteht ein Spannungsabfall  $\Delta v$  an  $R_5$  und  $\Delta v_{BE}$  in Q3, so daß die Emitterspannung (Basis von Q3) von Q1 höher als  $\Delta v + \Delta v_{BE}$  im Vergleich zu der Vorspannung ohne Signal wird, wodurch die Basisvorspannung von Q5 zunimmt. Wenn die Basisvorspannung von Q5 zunimmt, erhöht sich auch die Stromstärke; die Spannung an  $R_7$  nimmt zu und die Basisvorspannung von Q6 ändert sich nicht gegenüber dem Bezugspunkt (A). Die über Q6, Q8 und D2 angelegte Basisvorspannung von Q2 wird daher auf etwa dem gleichen Wert wie ohne Signal gehalten, so daß weiterhin ein Ruhestrom fließt. Bei einem negativen Signal tritt der umgekehrte Vorgang ein, so daß die Basisvorspannung von Q1 konstant gehalten wird. Im wirklichen Schaltkreis werden die Regelwiderstände  $R_2$  und  $R_4$  für die Einstellung des Ruhestromes verwendet, wobei ebenfalls ein Schaltkreis für thermische Kompensation zum Einsatz gelangt.

• Treiberschaltkreis für LED-Leistungsmesser

Für die Anzeige des Ausgangspegels werden 12 Leuchtdioden (LED) (HA3700 7 Leuchtdioden) pro Kanal verwendet. Diese Leuchtdioden werden über den Instrumenten-Schaltkreis angetrieben. Der Zusammenhang zwischen der Ausgangsleistung und der Anzahl der aufleuchtenden LEDs bei Verwendung von Lautsprecherboxen mit einer Impedanz von 8 Ohm ist in Abb. 10 dargestellt. In Abb. 11 ist der Schaltplan für die Leistungsmesser abgebildet.

HA-4700

• Entzerrer-Verstärker-Schaltkreis (Abb. 12)

Dieser Schaltkreis besteht aus einem rauscharmen

# CHECKING THE OPERATION OF THE PROTECTION CIRCUIT

When the output circuit is repaired by replacing the power transistors, etc., perform an operation check on the ASO (Area of Safe Operation) detection circuit and the speaker protection circuit.

## 1. Operation check of the ASO detection circuit for the output transistors

Connect the audio oscillator to the TUNER IN terminals with the speaker terminals unloaded (speaker: disconnect). Set the frequency of the audio oscillator at 1kHz and adjust the level of the input signal so that the voltage at the speaker terminals is approx. 5V rms.

Under these conditions, short-circuit the speaker terminals of the channel to which the input signal is applied using a lead wire, etc. If this short-circuit makes the ASO detection circuit operate, no output appears at the speaker terminals even if the lead wire used for short-circuiting is removed.

Next, turn off the power switch and, after approx. 10 sec., turn the power switch on again. When output comes out of the speaker terminals, this indicates that the ASO detection circuit is operating normally.

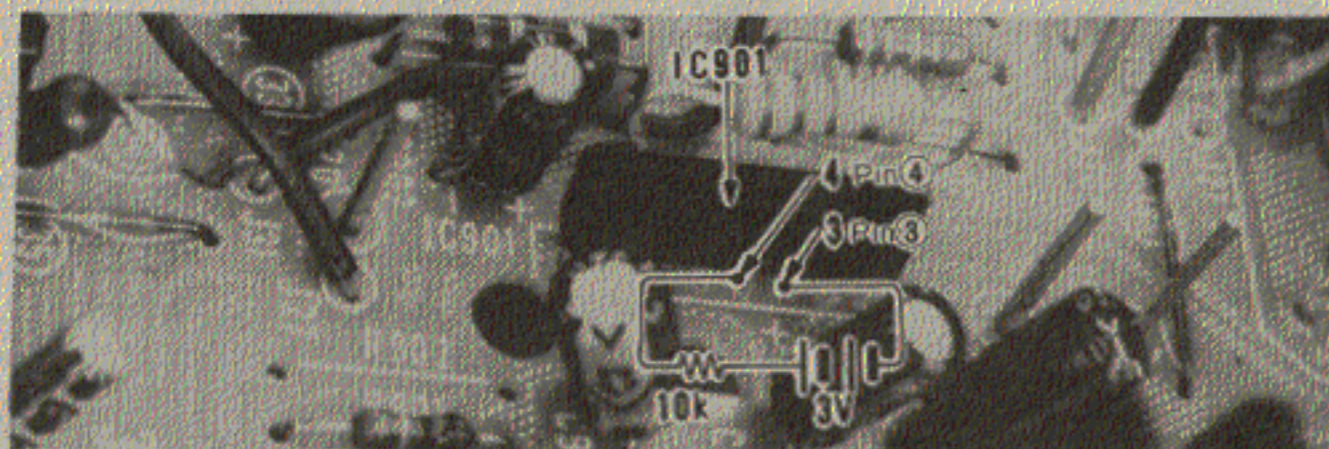

Fig. 13

## 2. Operation check of the speaker protection circuit

Make sure that the relay operates (a click sound is heard) approx. 6 – 10 seconds after the power switch is turned on with the speaker terminals unloaded (speaker: disconnect).

Next, when a resistor of approx. 10 kohms and 2 batteries (1.5V) are connect in series to the pin 3 and the pin 4 of IC901 on the audio printed wiring board, the relay turns off within 1 sec. When the batteries are taken away, the relay operates again. Next, change the polarities of the batteries and carry out the above-mentioned operation to check the operation of the relay.

When the relay operates normally in the above operation, it shows that the operation of the speaker protection circuit is normal. Be careful that the surrounding parts are not short circuited during this operation check.

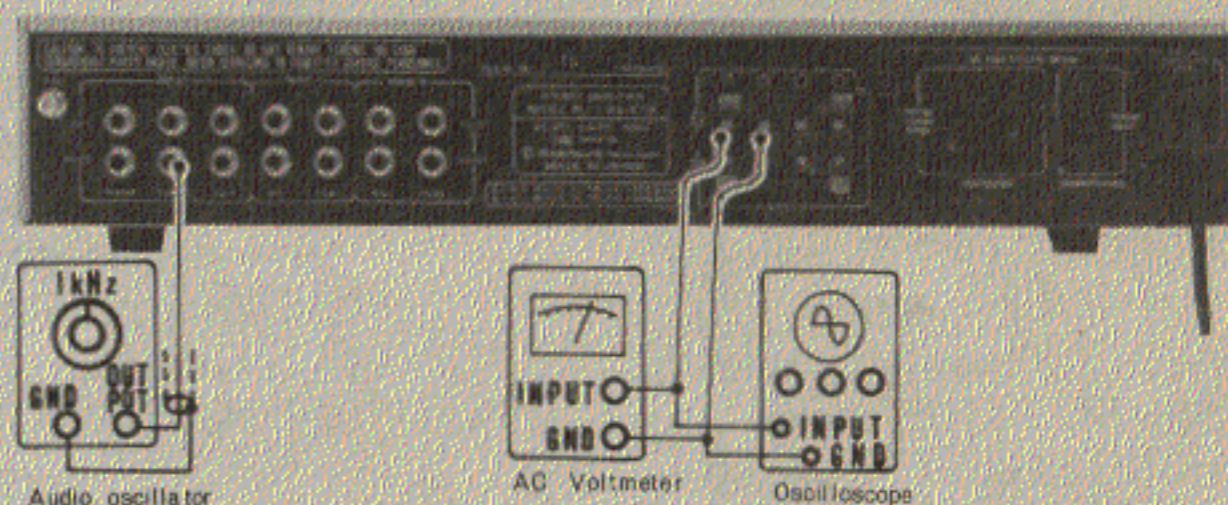

Fig. 14

## ● Phenomena and remedies when the protection circuit operates

