

HITACHI

SM0104

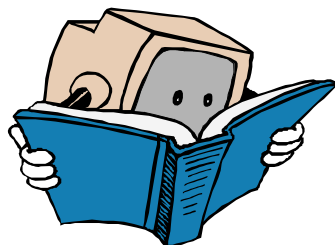

SERVICE MANUAL MANUEL D'ENTRETIEN WARTUNGSHANDBUCH

HCUR700UC
HCUR700E
HCUR700EBS
HCUR700W

CAUTION:

Before servicing this chassis, it is important that the service technician read the "Safety Precautions" and "Product Safety Notices" in this service manual.

ATTENTION:

Avant d'effectuer l'entretien du châssis, le technicien doit lire les «Précautions de sécurité» et les «Notices de sécurité du produit» présentés dans le présent manuel.

VORSICHT:

Vor Öffnen des Gehäuses hat der Service-Ingenieur die „Sicherheitshinweise“ und „Hinweise zur Produktsicherheit“ in diesem Wartungshandbuch zu lesen.

Data contained within this Service manual is subject to alteration for improvement.

Les données fournies dans le présent manuel d'entretien peuvent faire l'objet de modifications en vue de perfectionner le produit.

Die in diesem Wartungshandbuch enthaltenen Spezifikationen können sich zwecks Verbesserungen ändern.



CONTENTS

SPECIFICATIONS	3
SERVICE POINTS	4
ADJUSTMENTS & MEASUREMENT	11
WIRING DIAGRAM	17
PRINTED CIRCUIT BOARD	21
CIRCUIT DIAGRAM	43
BLOCK DIAGRAM	79
EXPLODED VIEW	83
REPLACEMENT PARTS LIST	87

SPECIFICATIONS AND PARTS ARE SUBJECT TO CHANGE FOR IMPROVEMENT

**MINI COMPONENT HI-FI SYSTEM
OCTOBER 2000**

SAFETY PRECAUTIONS

The following precautions should be observed when servicing.

1. Since many parts in the unit have special safety-related characteristics, always use genuine Hitachi's replacement parts. Especially critical parts in the power circuit block should not be replaced with other makers. Critical parts are marked with ! in the circuit diagram and printed wiring board.
2. Before returning a repaired unit to the customer, the service technician must thoroughly test the unit to ascertain that it is completely safe to operate without danger of electrical shock.

Check that exposed parts are acceptably insulated from the supply circuit before returning the repaired instrument to the customer.

- **Checking method**

Measure the resistance value between the both poles of attachment cup (Power supply plug) and the exposed parts (Parts such as Knob, Cover, etc. where the customer is easy to touch.) and check that the resistance value is 500 kohms or more.

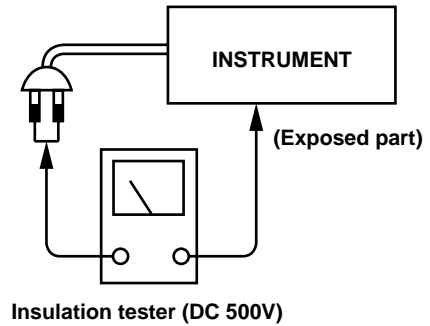

SPECIFICATIONS

• AV SURROUND RECEIVER SECTION (HTA-R150)

Reception frequency band	: UC FM: 87.5 ~ 108.0 MHz (100 kHz step) AM: 520 ~ 1710 kHz (10 kHz step) E, EBS FM: 87.50 ~ 108.00 MHz (50 kHz step) AM: 522 ~ 1611 kHz (9 kHz step) W FM: 87.50 MHz - 108.00 MHz (50 kHz step) AM: 522 ~ 1611 kHz (9 kHz step) 520 kHz - 1710 kHz (10 kHz step)
Rated output power	: Front: 25W + 25W (6Ω/ohms, 50 Hz - 15 kHz with 0.7% T.H.D.) : Center: 25W (6Ω/ohms, 50Hz - 15kHz with 0.7% T.H.D.) : Rear: 25W + 25W (6Ω/ohms, 50Hz - 15kHz with 0.7% T.H.D.) : Front: 30W + 30W (6Ω/ohms, 1 kHz with T.H.D. 10%) : Center: 30W (6Ω/ohms, 1 kHz with T.H.D. 10%) : Rear: 30W + 30W (6Ω/ohms, 1 kHz with T.H.D. 10%)
Audio input / output jacks	: Input jacks: DVD, TV/DBS, VCR, MD/TAPE, VIDEO AUX Output jacks: VCR, MD/TAPE
Audio digital input jacks	: OPTICAL 1, OPTICAL 2
Video input / output jacks	: Input jacks: DVD, TV/DBS, VCR, AUX Output jacks: VCR, MONITOR
Power supply	: UC : AC 120V 60Hz E, EBS : AC 230V 50Hz W : AC 110 ~ 127V 50/60Hz : AC 220 ~ 240V 50/60Hz
Power consumption	: UC : 180W (include AC OUTLET : 60W) E, EBS : 115W W : 115W STANDBY : 0.8W
Maximum external dimensions	: 210 (W) x 120 (H) x 324 (D) mm (including feet, controls and terminals)
Weight	: 5.3 kg
Timer	: Digital Quartz Clock. Display Format: 24-hour cycle. (E, EBS, W), 12-hour cycle (UC) Timer accuracy: Within 60 seconds at the monthly rate.

• DVD/CD/VIDEO CD PLAYER SECTION (HDV-R100)

Applicable discs	: DVD discs: 12cm discs (1 layer and 2 layer) 8cm discs (1 layer and 2 layer) Compact discs (CD-DA Video CD): 12cm discs, 8cm discs
Audio output jacks	: AUDIO OUT (Fixed output level: 2Vrms)
Digital output jacks	: OPTICAL
Video output jacks	: VIDEO OUT, S VIDEO OUT, COMPONENT VIDEO OUT
Video output level	: VIDEO OUT: 1V _{p-p} (75Ω/ohms) S VIDEO: Y; 1V _{p-p} (75Ω/ohms), C; 0.3V _{p-p} (75Ω/ohms) COMPONENT: Y; 1V _{p-p} (75Ω/ohms), CB; 0.7V _{p-p} (75Ω/ohms) CR; 0.7V _{p-p} (75Ω/ohms)
Audio frequency response	: DVD: 2 Hz to 22 kHz (48 kHz sampling), 2 Hz to 44 kHz (96 kHz sampling) CD: 2 Hz to 22 KHz (44.1 kHz sampling)
Power supply	: UC : AC 120V 60Hz E, EBS : AC 230V 50Hz W, WUN: AC 110 ~ 127V 50/60Hz : AC 220 ~ 240V 50/60Hz
Power consumption	: 14W
Maximum external dimensions	: 210(W) x 96.5(H) x 309(D) mm (including feet, controls and terminals)
Weight	: 2.8 kg

• REMOTE CONTROL SECTION

Remote control unit	: RB-HTAR150 (for systems), RB-HDVR100 (for HDV-R100)
Remote control system	: Infrared pulse
Power supply	: Two DC 1.5V R6P/AA batteries

* Specifications are subject to change for performance improvement without notice.

SERVICE POINTS

• AV SURROUND RECEIVER (HTA-R150)

1. Removal of Top Cover

- (1) Remove 4 screws **1** from each side.
- (2) Remove 4 screws **2** from the rear plate.

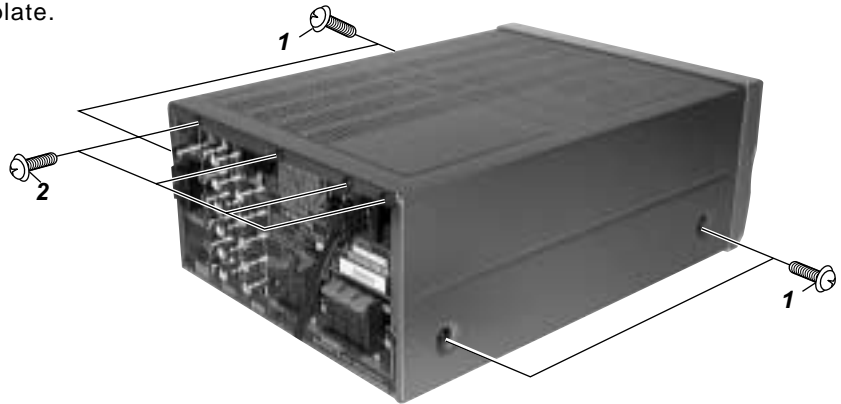

Fig. 1

2. Removal of Front Panel

- (1) Remove 4 screws **5** from the bottom of the front panel.
- (2) Remove 2 screws **3** and 2 catches from both side.
- (3) Remove 2 screws **4**.
- (4) Remove Connector **A**.
- (5) Remove 2 screws **6** of P.W.B. bracket to remove Connector **B** to **H**.

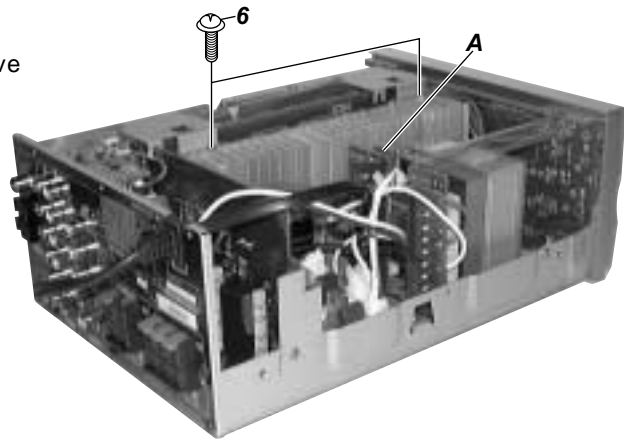

Fig. 3

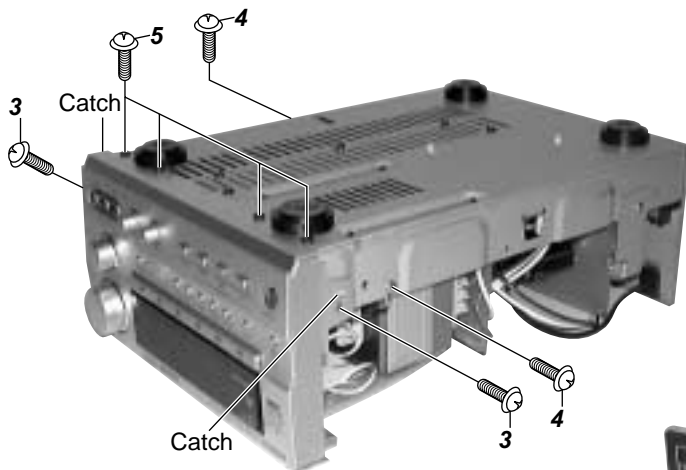

Fig. 2

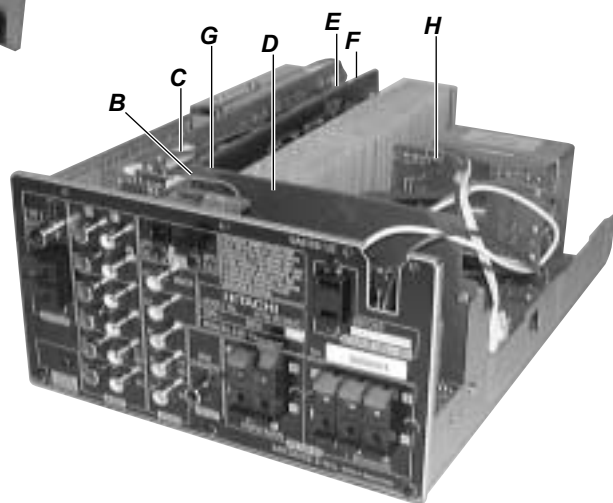

Fig. 4

- 3. Removal for Rear Panel
 - (1) Remove 20 screws **7**.

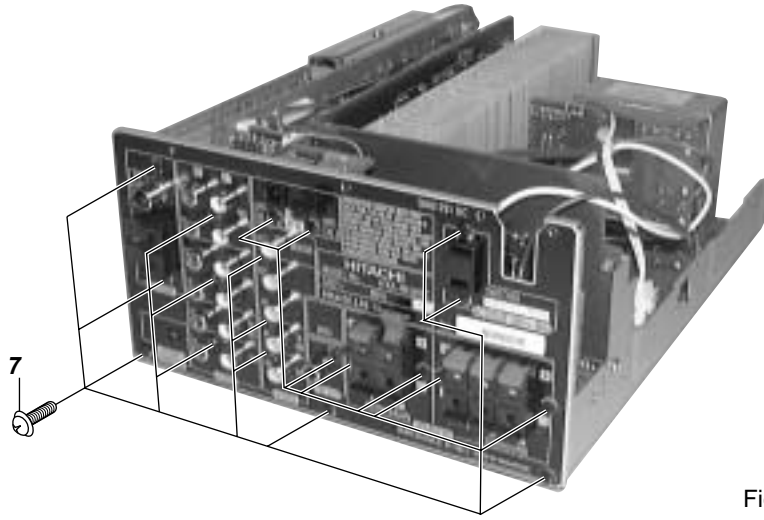

Fig. 5

- 4. Removal of Power Transformer
 - (1) Remove the 4 screws **8**.
 - (2) Remove Connector **I** to **K**.

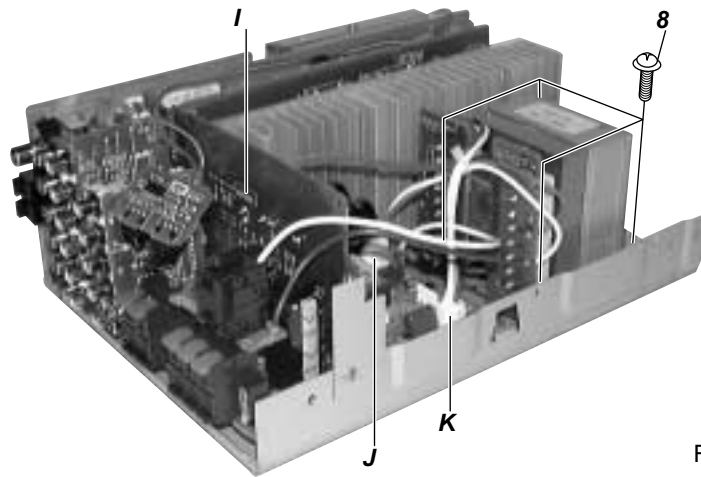

Fig. 6

5. Removal of P.W.B. Board.

- (1) Remove 1 screw **9** and 1 screw **10**.
- (2) Remove 2 screw **11**.
- (3) Remove 5 screws **12** from the bottom of chassis.
- (4) Remove 2 pieces of P.W.B. holder **a** from the bottom chassis.

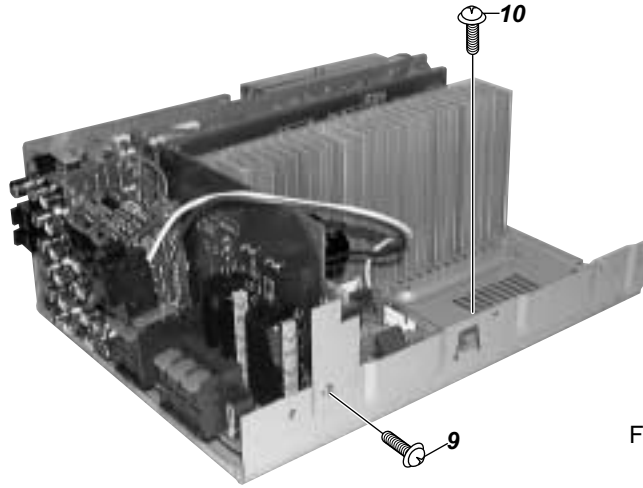

Fig. 7

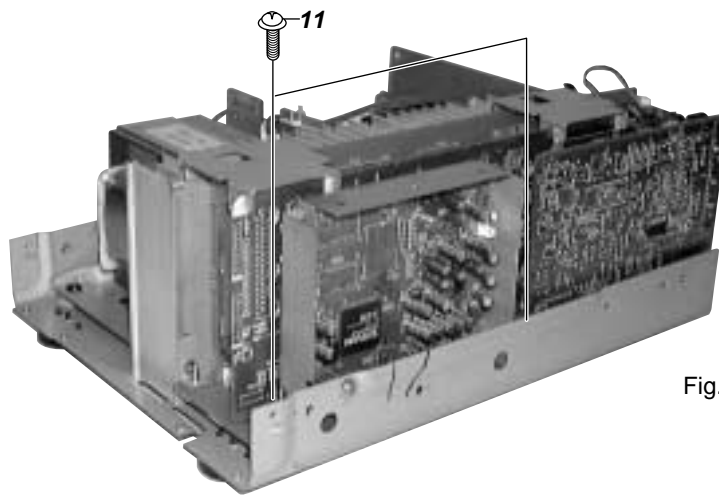

Fig. 8

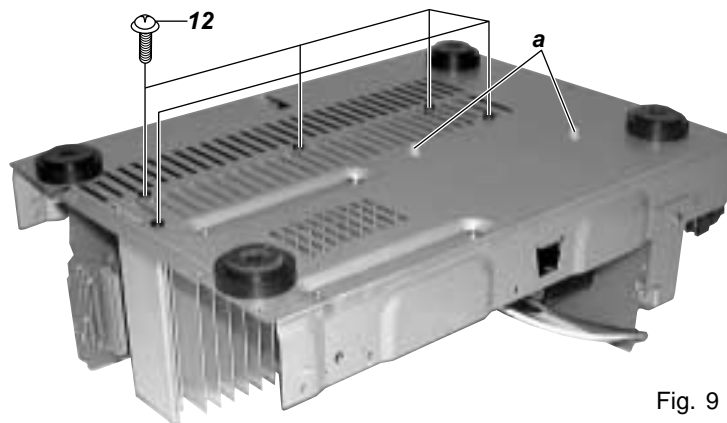

Fig. 9

6. Removal of Front P.W.B. Board.

- (1) Pull the Volume knob away, and remove the nut.
- (2) Pull out 2 Bass/Treble knobs and remove the nuts.
- (3) Remove the Function knob.
- (4) Remove 9 screws **13**.

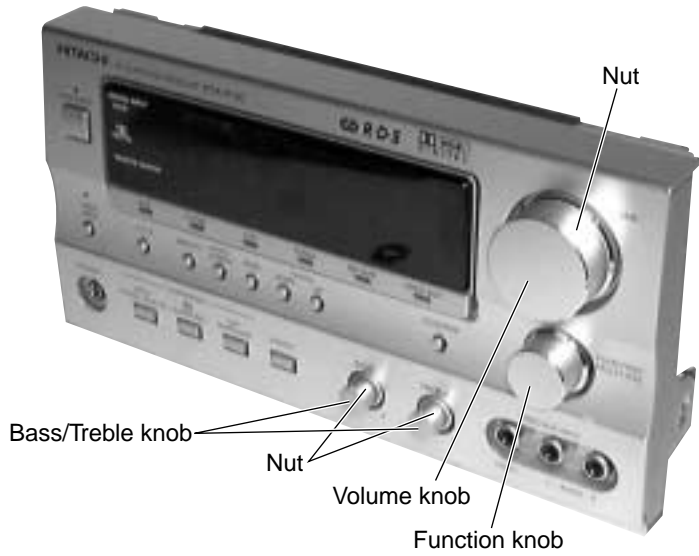

Fig. 10

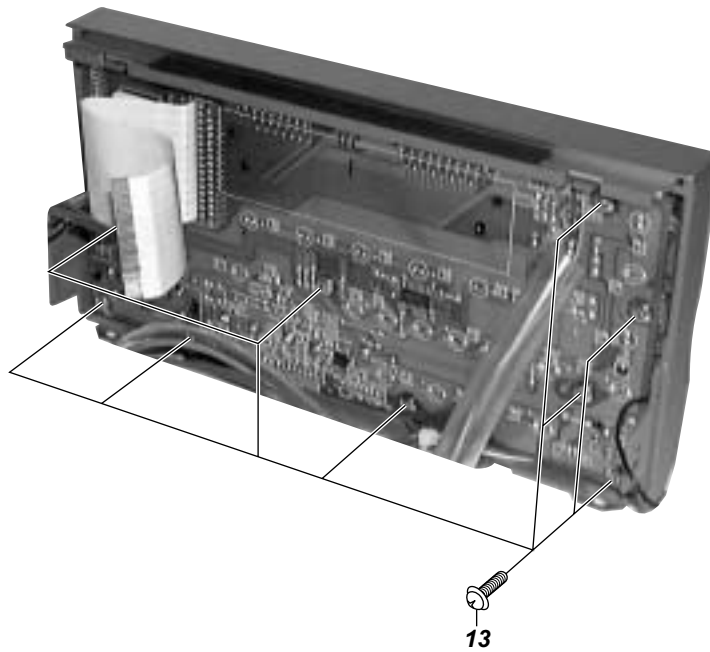

Fig. 11

• **DVD/CD/VIDEO CD PLAYER (HDV-R100)**

1. Removal of Top Cover

- (1) Remove 2 screws **1** from both side.
- (2) Remove 4 screws **2** from the rear panel.

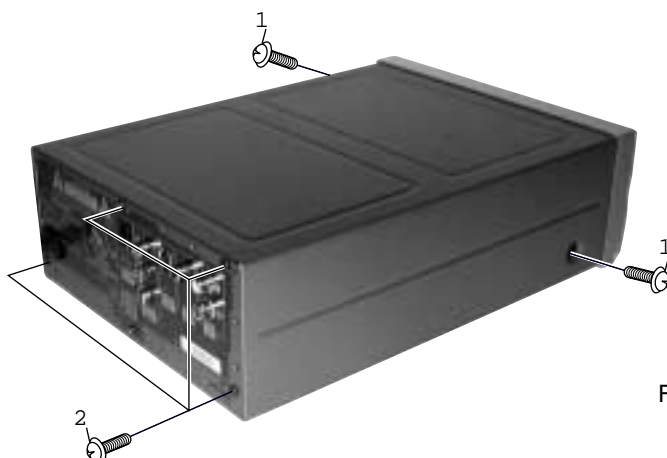

Fig. 1

2. Removal of Front Panel

- (1) Remove 4 screws **3** from the bottom of the front panel.
- (2) Remove 2 screws **4** and 2 catches from both side.
- (3) Remove Connector A and B.

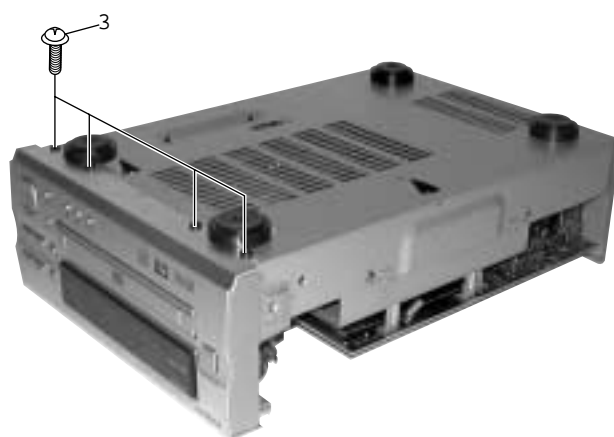

Fig. 2

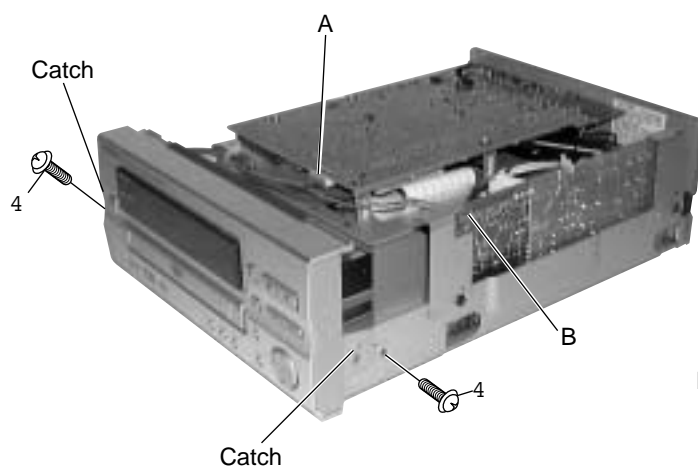

Fig. 3

3. Removal of Rear Panel
 (1) Remove 6 screws **5**.

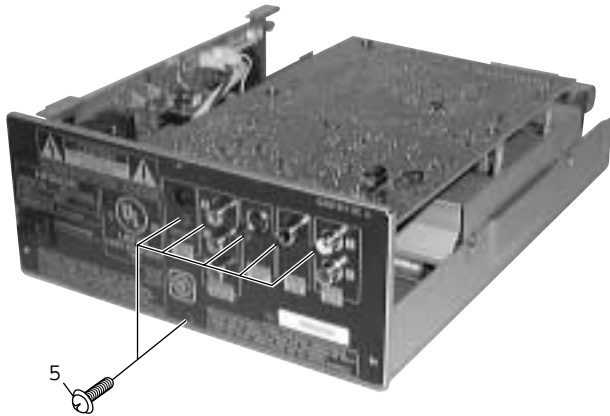

Fig. 4

4. Removal of Main P.W.B. Board
 (1) Remove 4 screws **6**.
 (2) Remove Connector C and D.

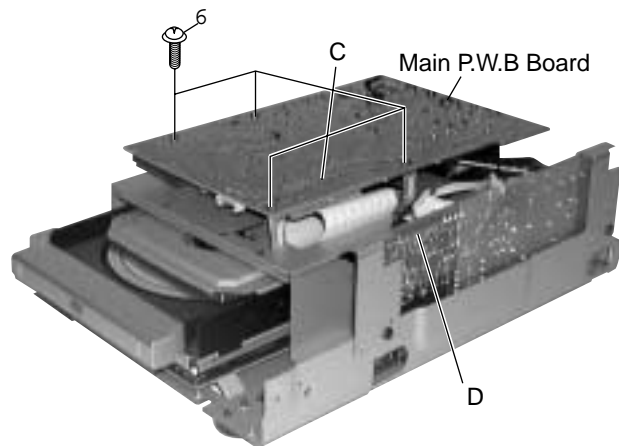

Fig. 5

5. Removal of Power Supply Board
 (1) Remove 4 screws **7**.
 (2) Remove Connector E.

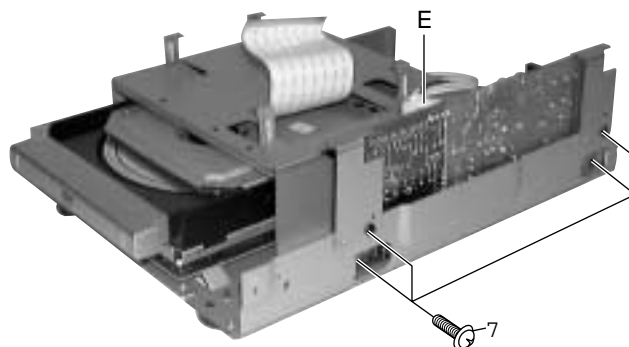

Fig. 6

6. Removal of Deck Mechanism Assy

- (1) Remove 4 screws **8** to release the mechanism cover.
- (2) Remove 4 screws **9**.

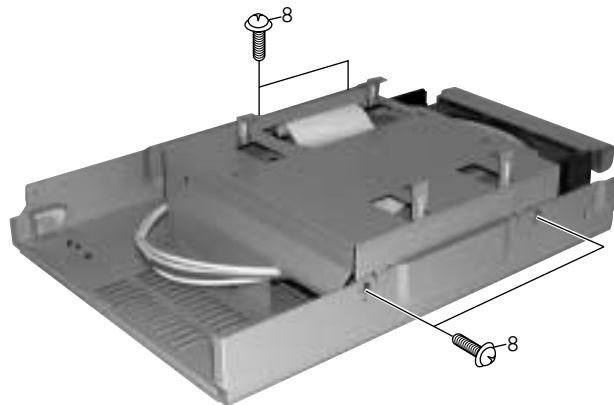

Fig. 7

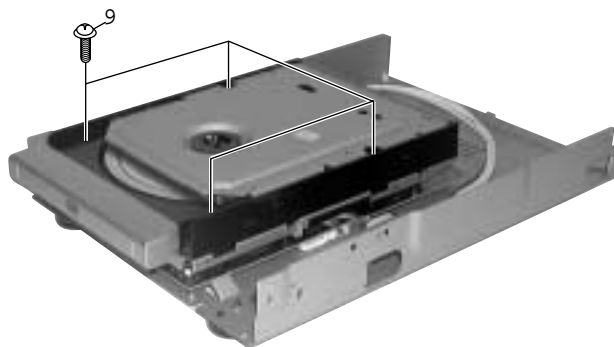

Fig. 8

7. Removal of Front P.W.B. Board

- (1) Remove away the Front Metal.
- (2) Pull out the Enter Button.
- (3) Remove 9 screws **10**.

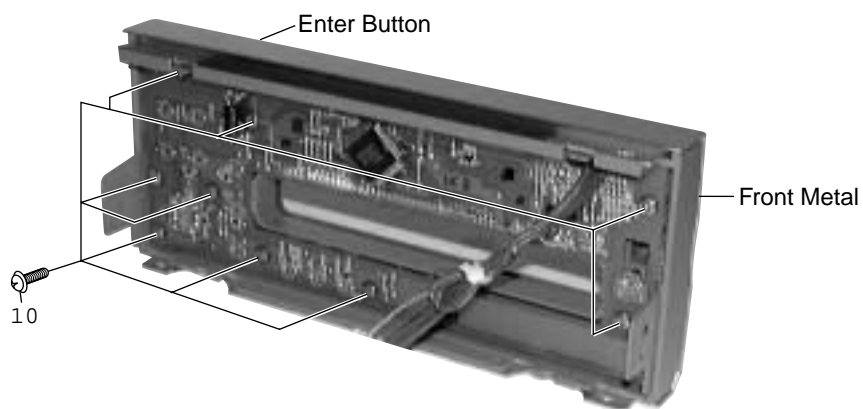
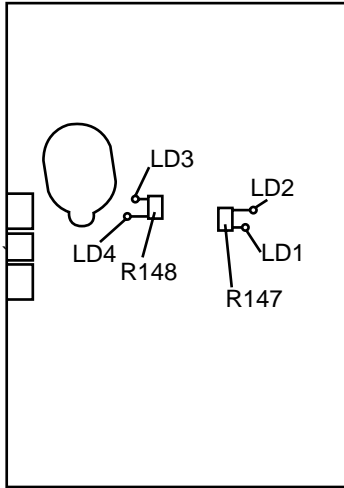

Fig. 9

IOP MEASUREMENT METHOD

When measuring Laser drive current (Iop), playback the discs (CD, DVD) described below, measure Iop for CD Laser and DVD Laser by the test point (LD1 - LD4) on the SERVO P.W.B.

TEST DISC : DVD / DVDT-S01 (Manufactured by ALMEDIO INC)
 CD / TCD-784 (Manufactured by ALMEDIO INC) or commercially available Discs.



Mechanism Unit bottom side

1. DVD Laser current measurement

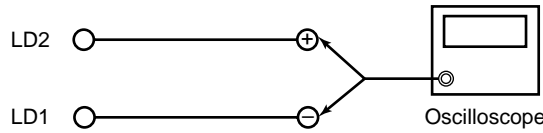

- (1) Connect the oscilloscope GND side to test point LD1 near R147 and oscilloscope signal side to test point LD2 near R147.
- (2) Playback the title 1 / chapter 1 of the DVD Test Disc.
- (3) Measure the voltage between LD1 and LD2, calculate Iop as follows.

$$Iop = \frac{\text{Measurement Voltage Value}}{39 \text{ (Resistance Value)}}$$

2. CD Laser current measurement

- (1) Connect the oscilloscope GND side to test point LD3 near R148 and oscilloscope signal side to test point LD4 near R148.
- (2) Playback the track 1 of the CD Test Disc.
- (3) Measure the voltage between LD3 and LD4, calculate Iop as follows.

$$Iop = \frac{\text{Measurement Voltage Value}}{39 \text{ (Resistance Value)}}$$

OPTICAL PICKUP DIAGNOSTICS AND REPLACEMENT

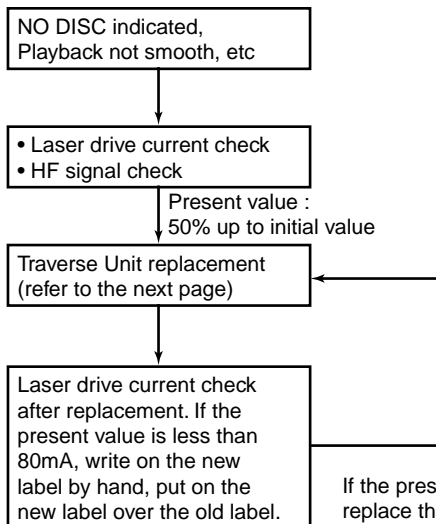

When repairing, carry out failure diagnostics by following the procedure described below.
 If the present value of the laser drive current is 50% up to initial value, it is the point of the pickup replacement.
 In case of the pickup replacement, replace the Traversal Unit with no adjustment.
 The initial value is indicated on the label on back side of Mecha.

If the present value exceeds 80mA,
 replace the Traversal Unit with a new one.
 Cause : Damaged electrostatically when replaced.

CHECKING THE WAVEFORMS

To check the waveforms on the SERVO P.W.B., the GND (-) probe of the Osilloscope to " ref" point.

NOTES

MEASURING DISC : DVD / DVDT-S01
 CD / TCD-784A

(It is better to use wires for extending between the probe and test points.)

- When watching the HF waveform, use the extending wire as short as possible.
- When HF waveform is noisy or can not discriminate the eye-pattern, replace the Traverse Unit after measuring the lop.
- Test points 1 ~ \$ are shown below.

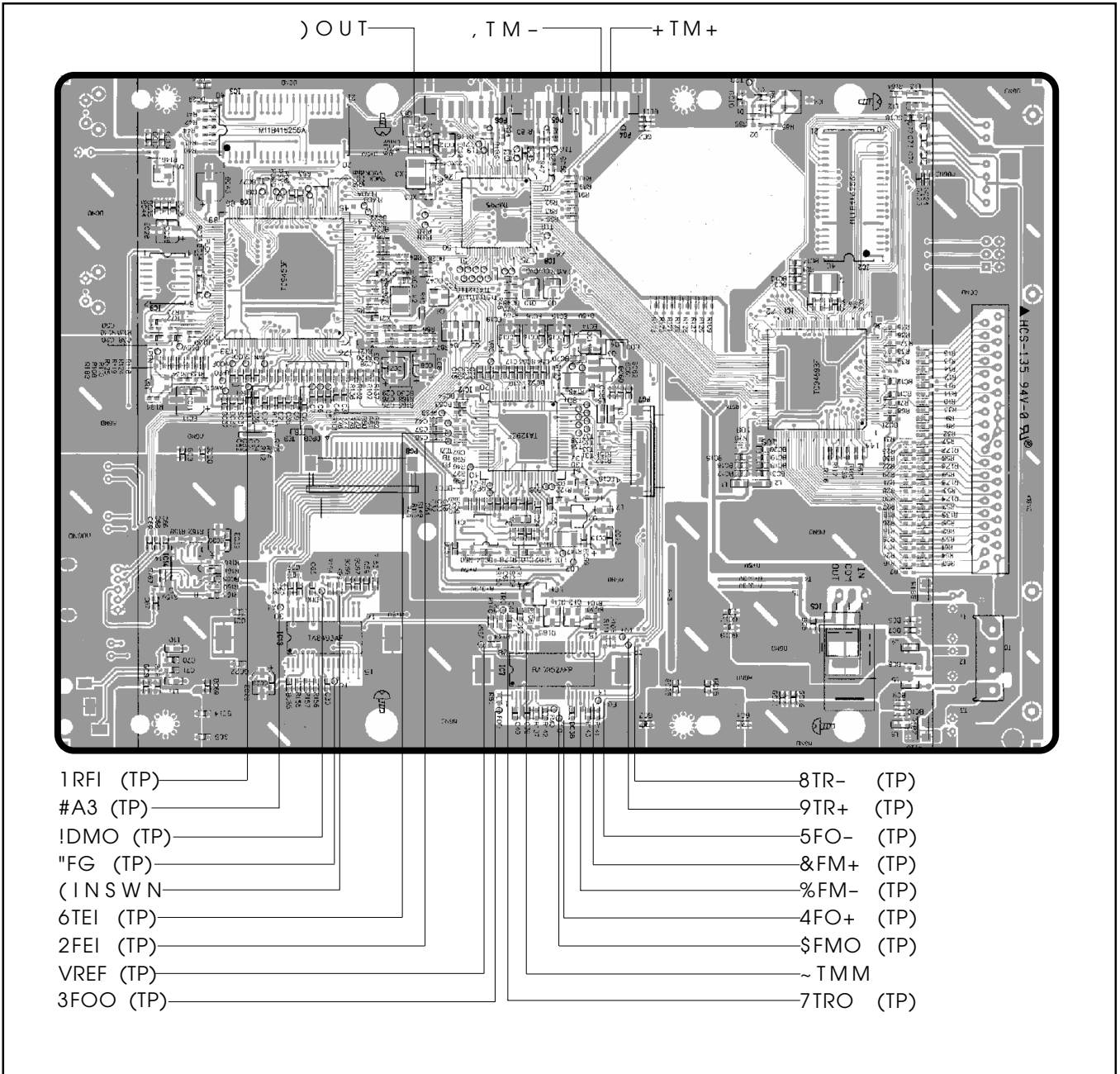

WAVEFORMS

DVD PLAY

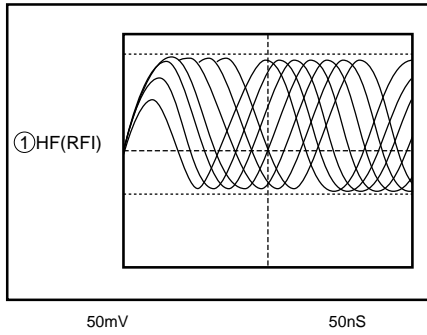

DVD PLAY

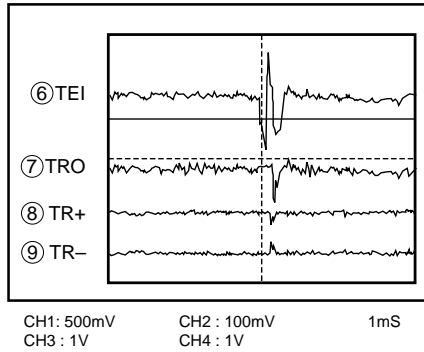

DVD PLAY (INNER)

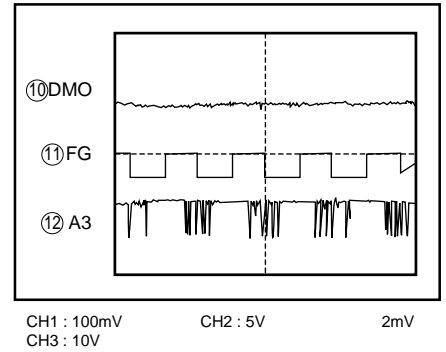

(DVD/CD) LOADING ∅ PLAY

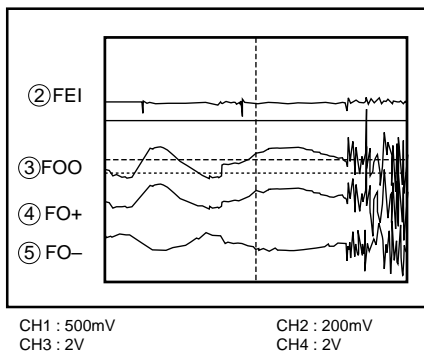

SEARCH TO OUTER CHAPTER
(INNER ∅ OUTER)

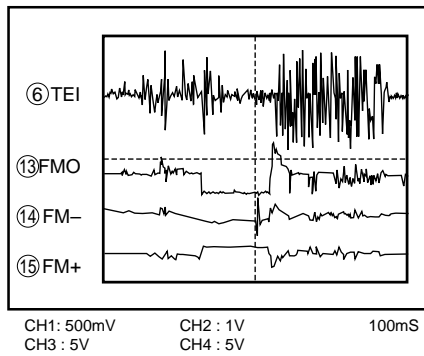

POWER ON
(INNER SWITCH ON)

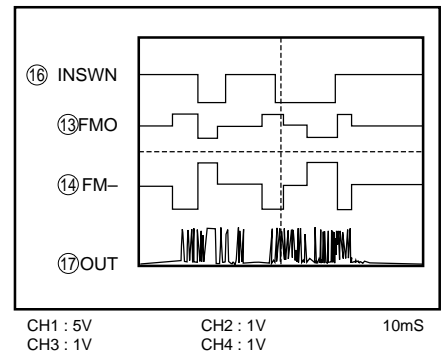

LOADER
(OPEN ∅ CLOSE)

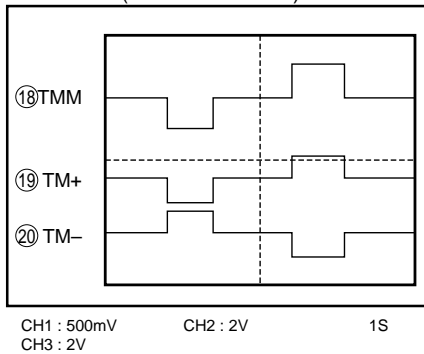

CD PLAY

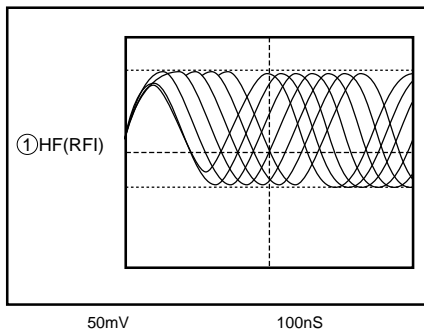

CD PLAY

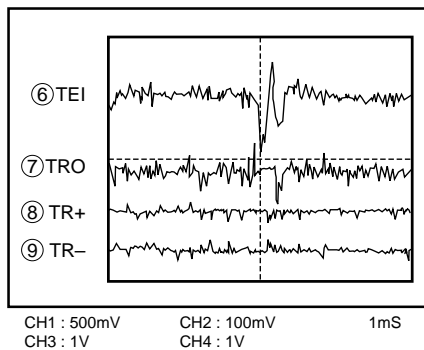

CD PLAY (INNER)

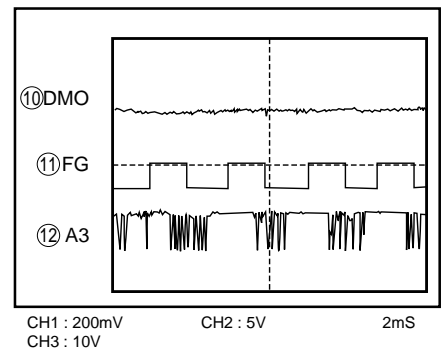

TROUBLE SHOOTING

1 No Power (Display tube and LED do not light up)

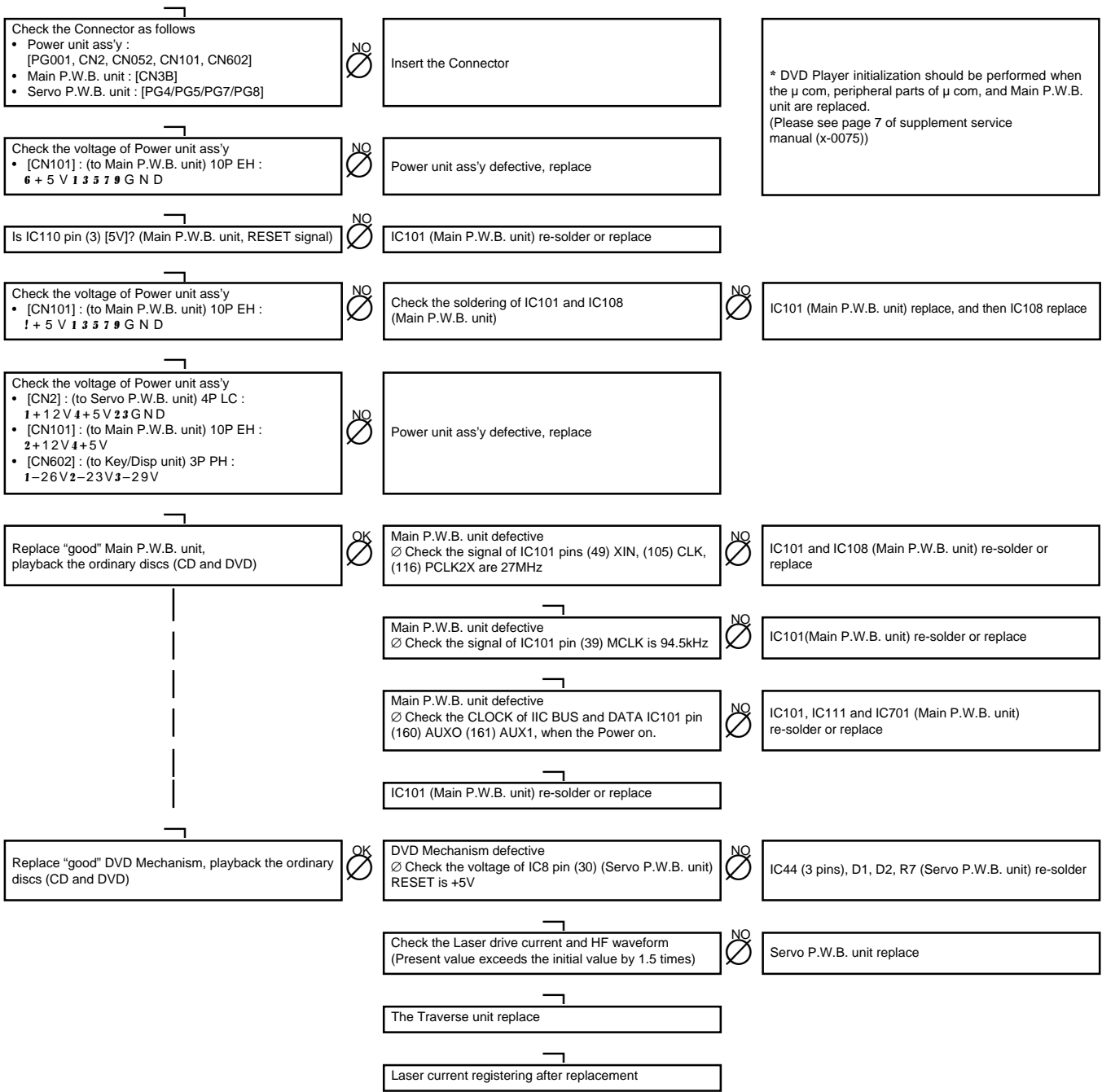

* DVD Player initialization should be performed when the μ com, peripheral parts of μ com, and Main P.W.B. unit are replaced.
(Please see page 7 of supplement service manual (x-0075))

2 Display tube does not light up (LED light up)

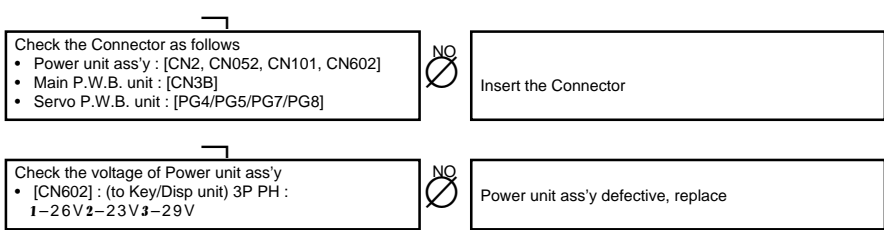

* Please check the marked * with of item 1 [No Power]

ADJUSTMENTS

Adjusting and Checking the Electrical Section
 Measuring instruments needed for the adjustments

- (1) Oscilloscope
- (2) DC voltmeter
- (3) Adjustment screwdriver
- (4) Test disc
 - TDV-540 Title2 Tr No. 1

1. Adjustment of + 5V Voltage
 Adjust R502 so that the voltage of PG101 Pin6 (+5V) should be within Limit of $5.0 \pm 0.05V$.

2. Adjustment of VIDEO OUT Level (Load: 75Ω).

	Video Output Terminal	Adjustment Vol	Specification
1.	Video Out	VR701	$1V \pm 80mVp-p$
2.	Video Out	VR702	$680 \pm 40mVp-p$
3.	CB	VR703	$480 \pm 20mVp-p$
4.	CR	VR704	$480 \pm 20mVp-p$

(1) Adjust VR701

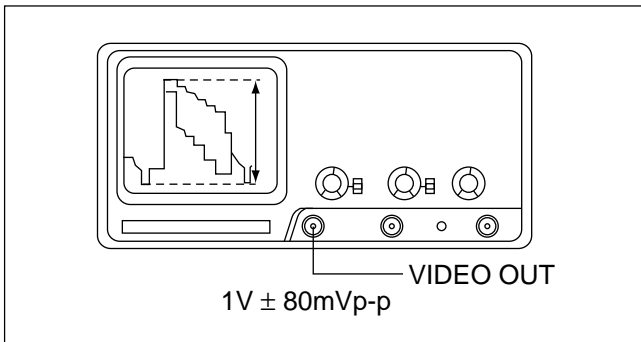

Output Cord Connect to VIDEO OUT

(3) Adjust VR703

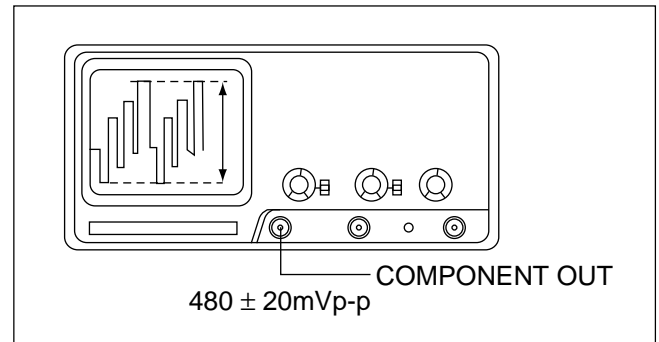

Output Cord Connect to CR

(2) Adjust VR702

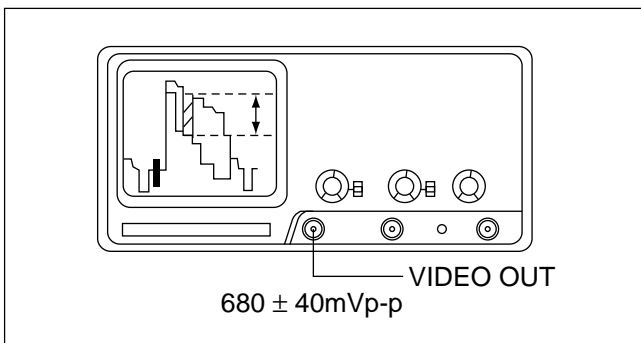

Output Cord Connect to VIDEO OUT

(4) Adjust VR704

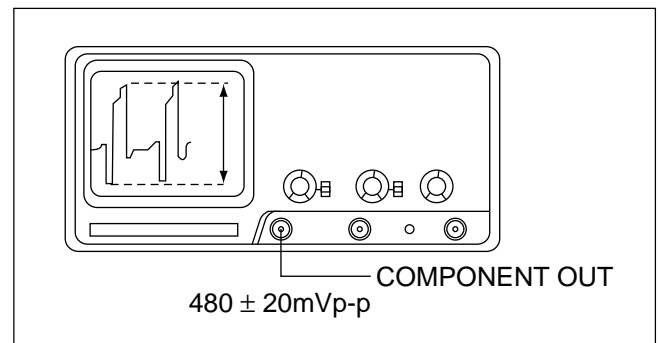

Output Cord Connect to CB

*Using Disc TDV-540 Title 2 Tr No. 1
 Fig. 1 Adjustment of VIDEO OUT Level (Load: 75Ω)

MEMO

WIRING DIAGRAM

• AV SURROUND RECEIVER (HTA-R150)

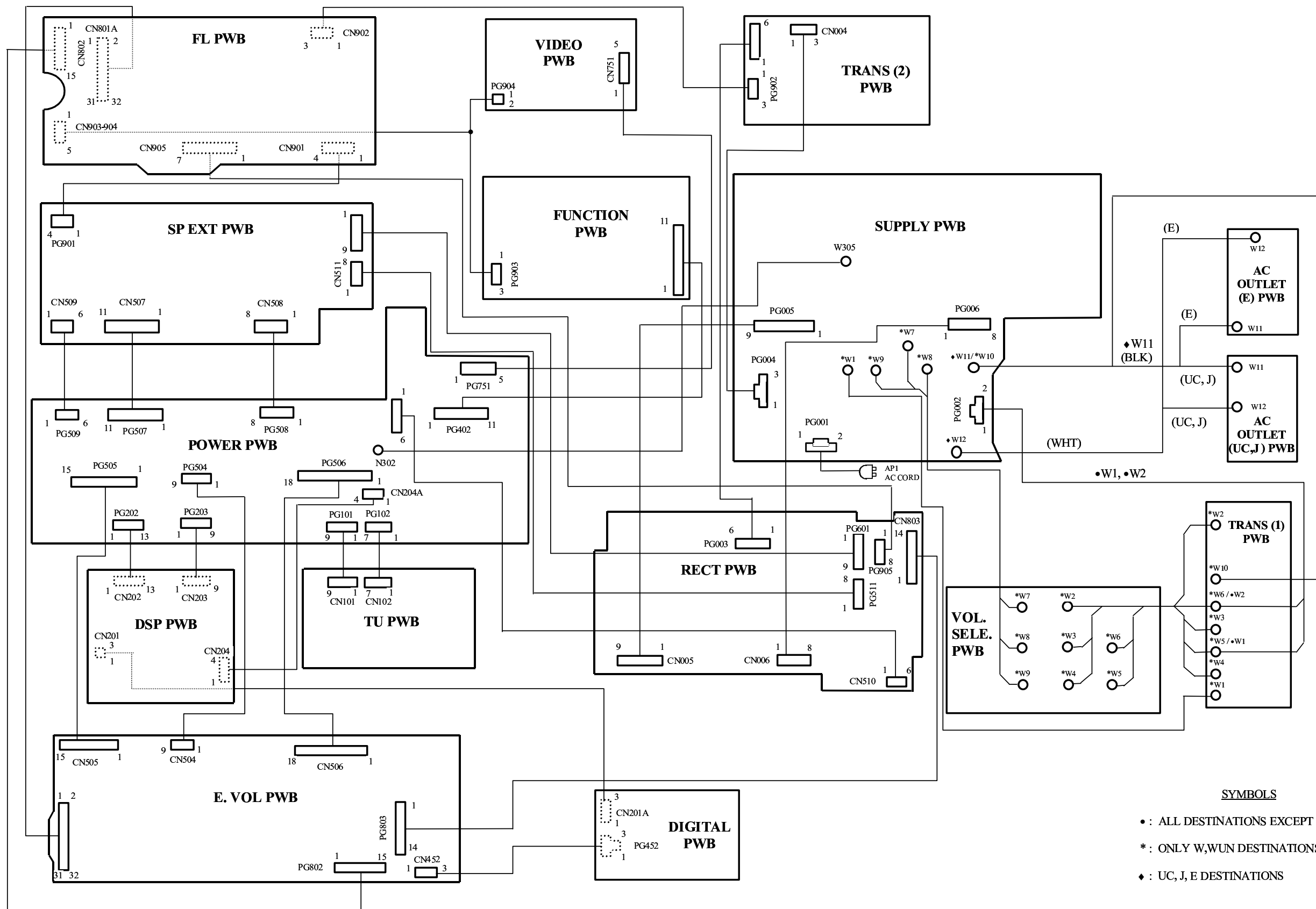

WIRING DIAGRAM

• DVD/CD/VIDEO CD PLAYER (HDV-R100)

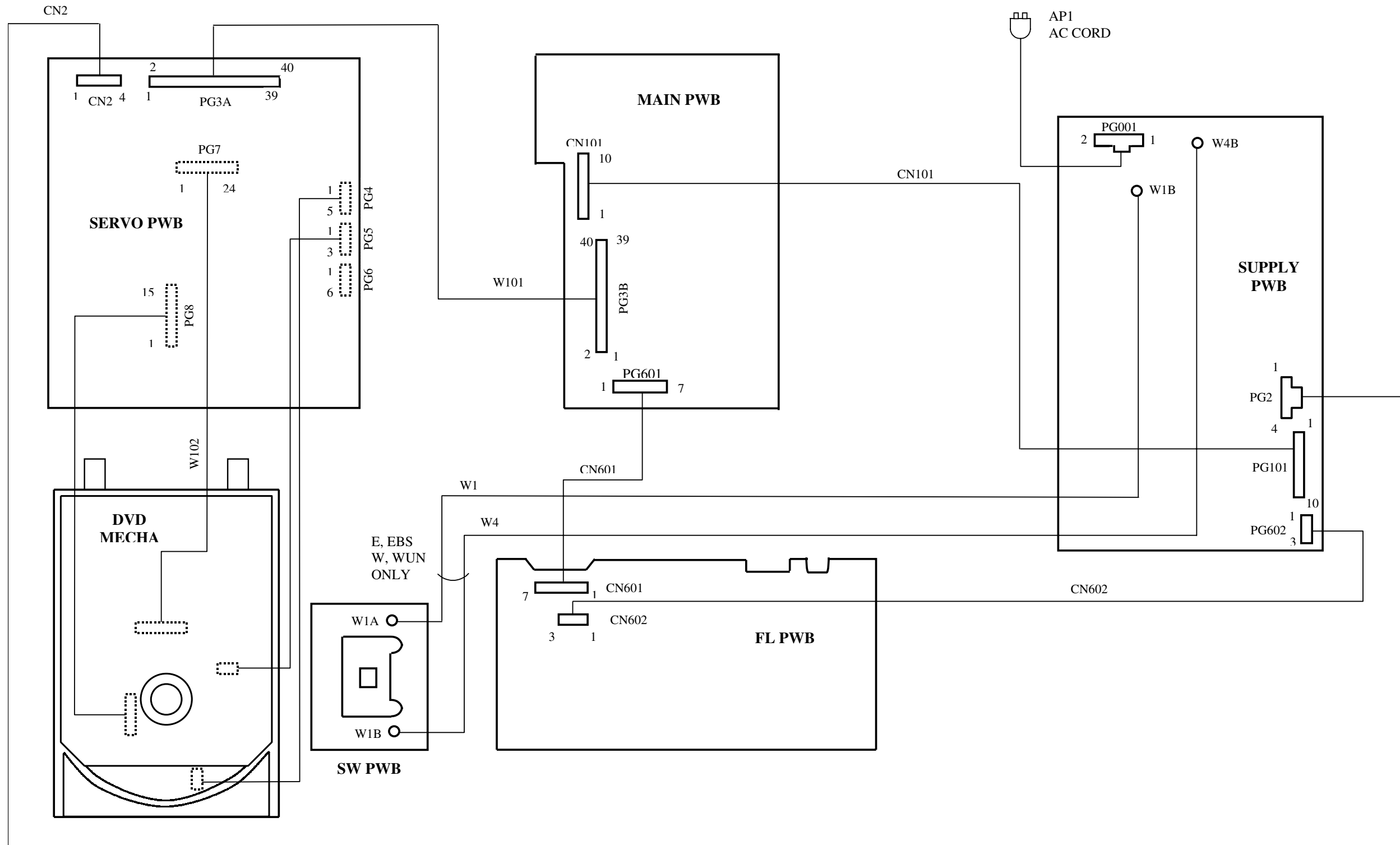

Component Side

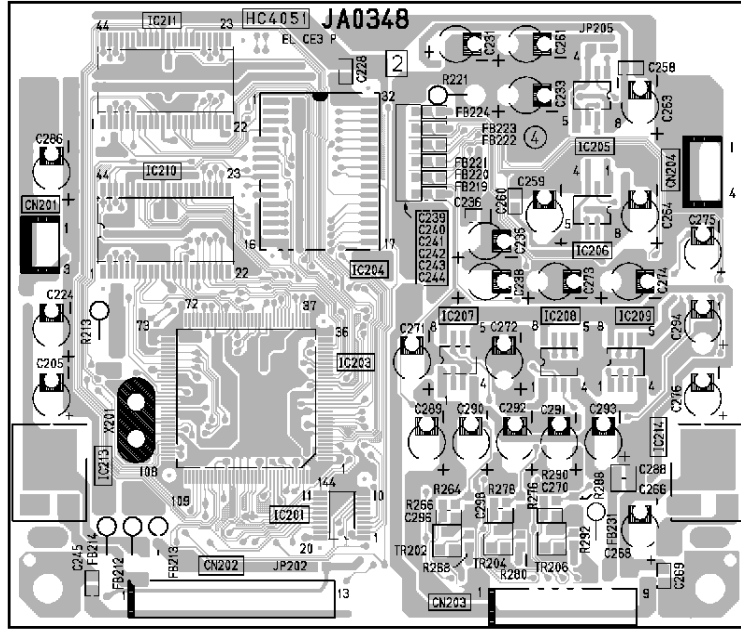

DSP PWB

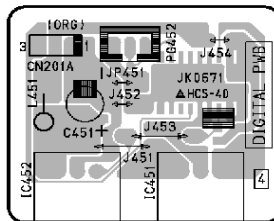

DIGITAL PWB

Soldering Side

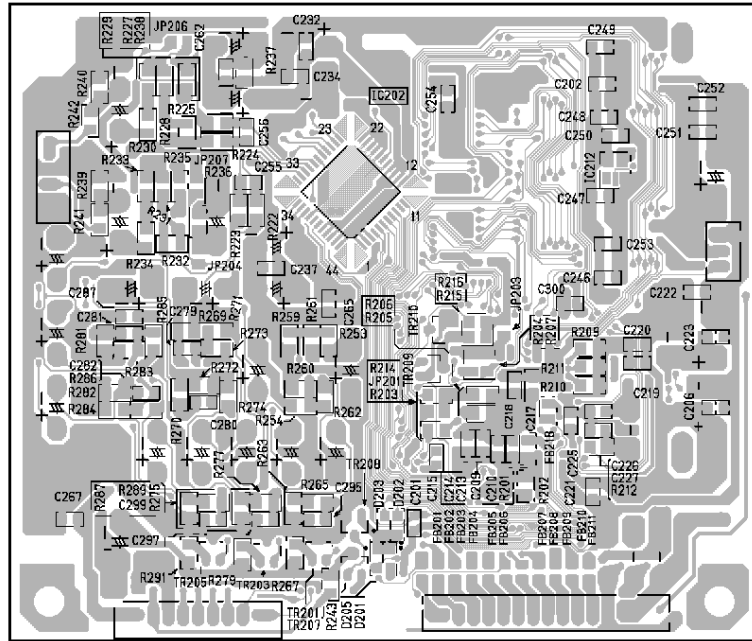

DSP PWB

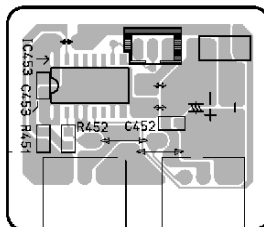

DIGITAL PWB

Component Side

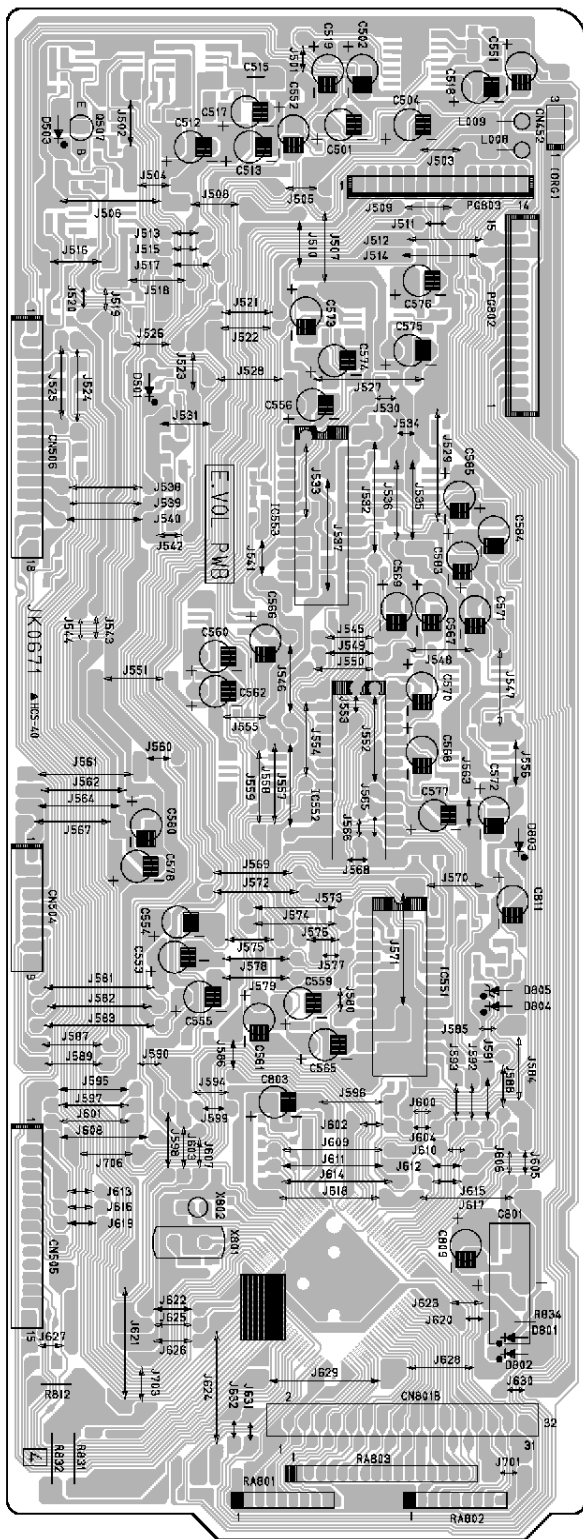

Soldering Side

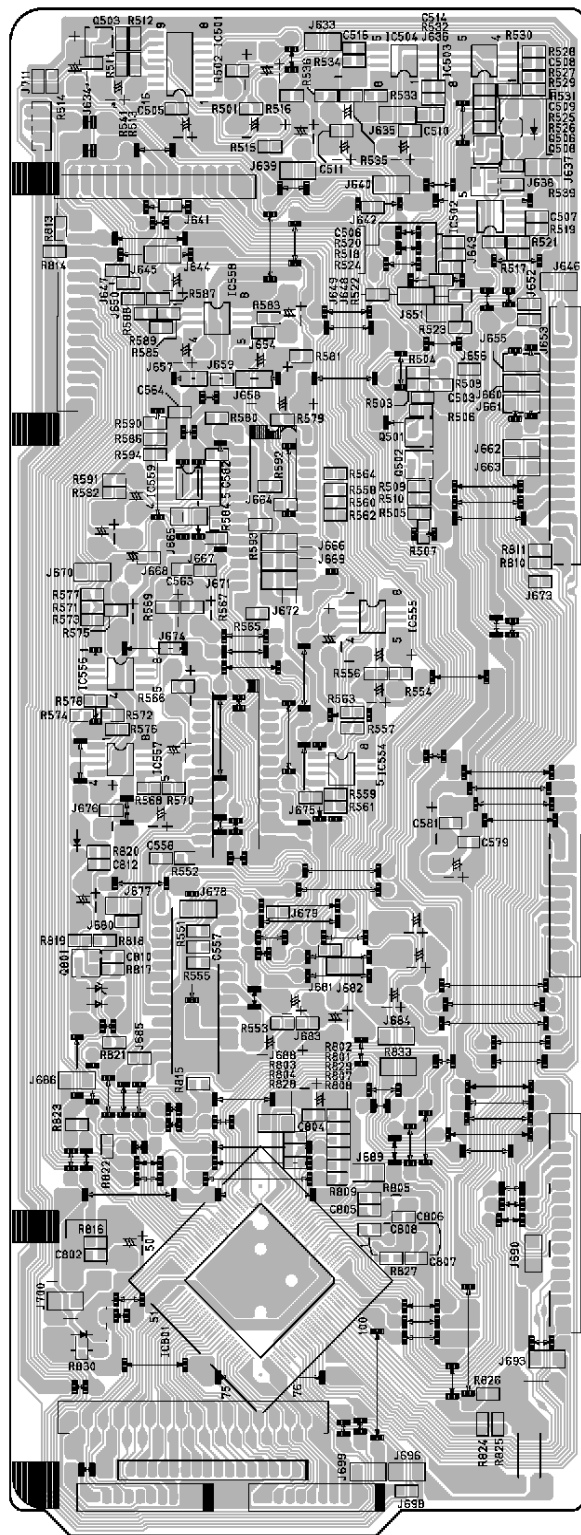

E.VOL PWB

Component Side

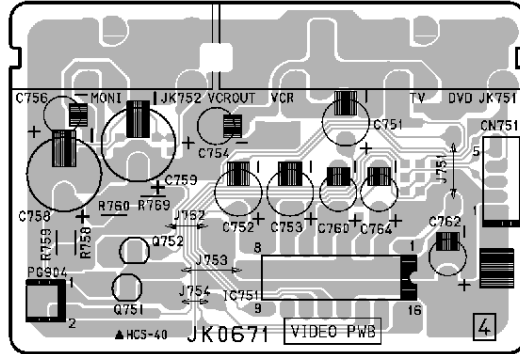

Soldering Side

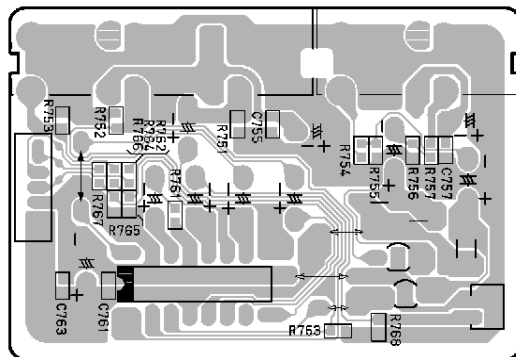

VIDEO PWB

Soldering Side

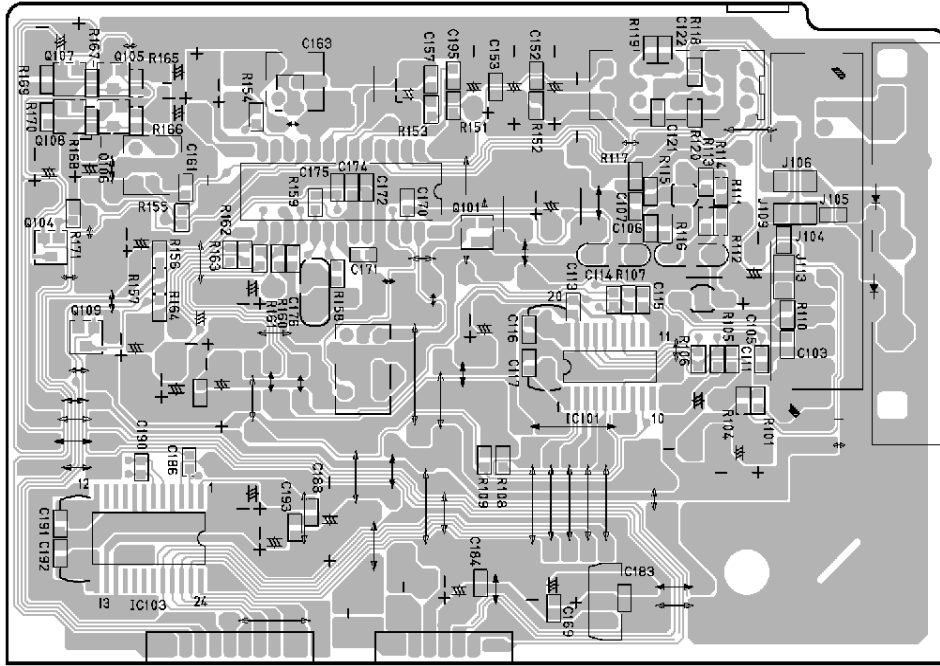

TU PWB

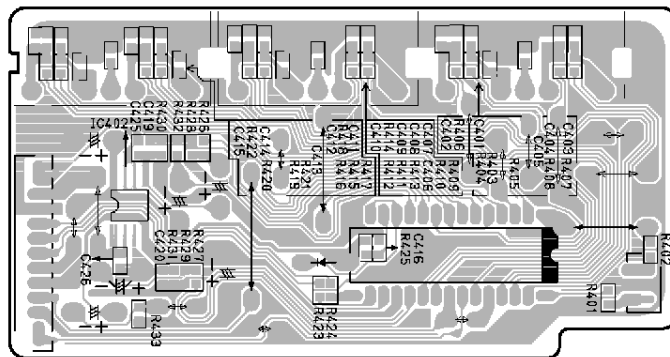

FUNCTION PWB

Soldering Side

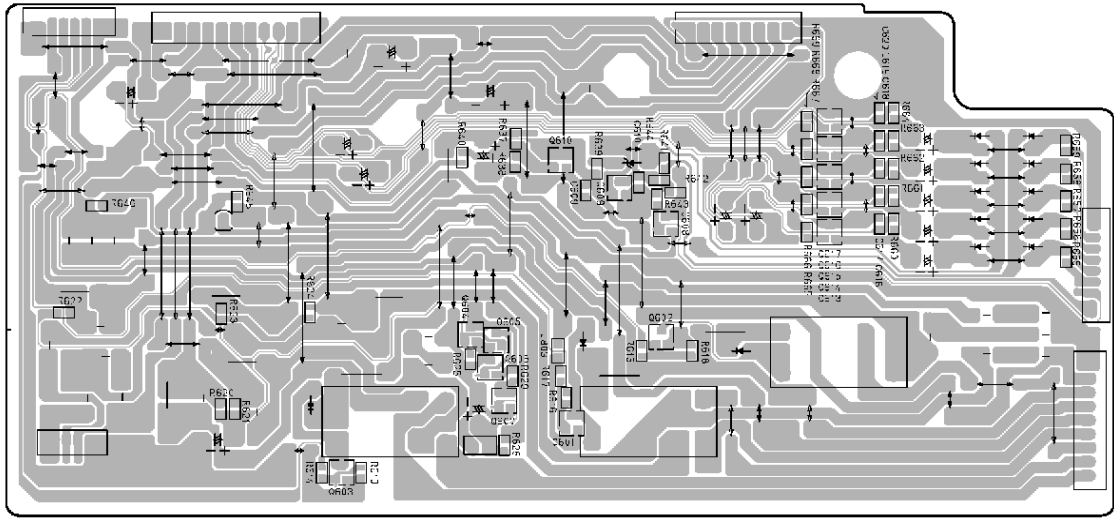

SP EXT PWB

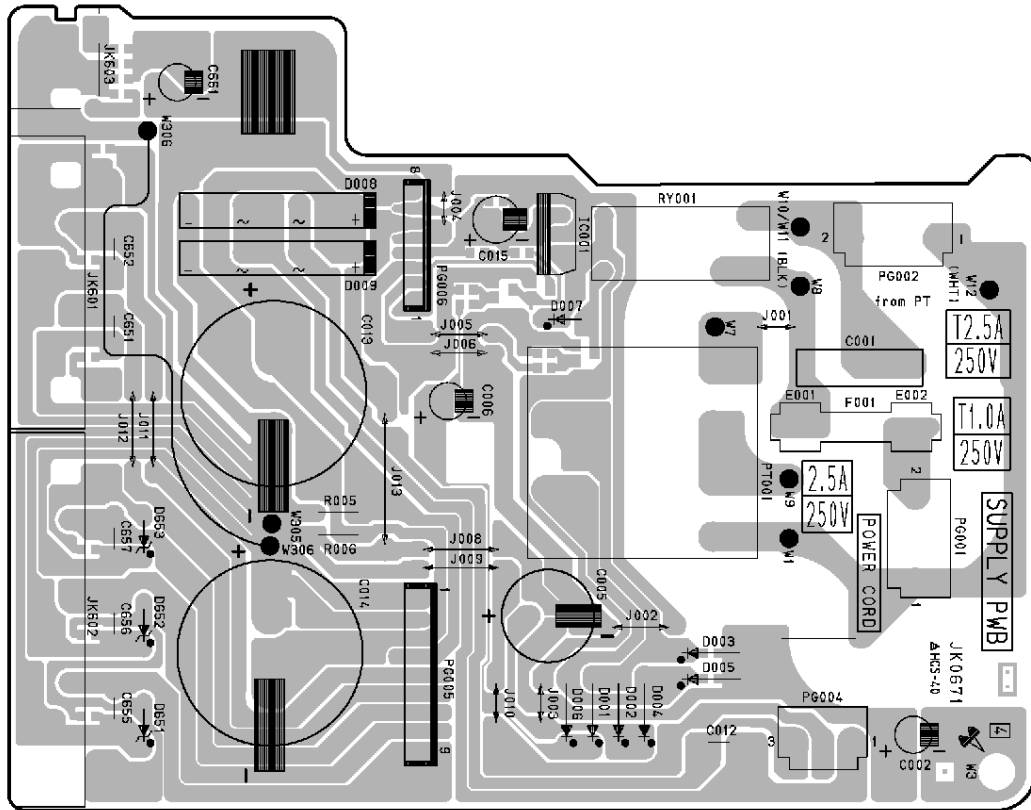

SUPPLY PWB

Component Side

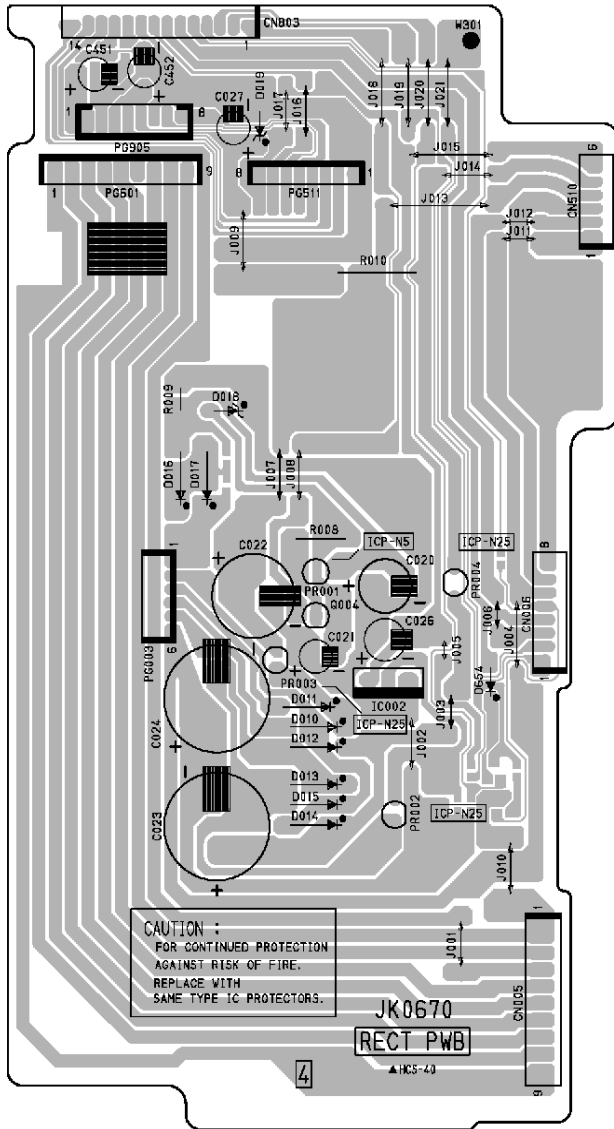

RECT PWB

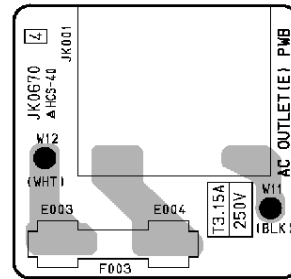

AC OUTLET (E) PWB

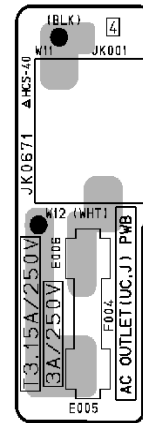

AC OUTLET (UC) PWB

Soldering Side

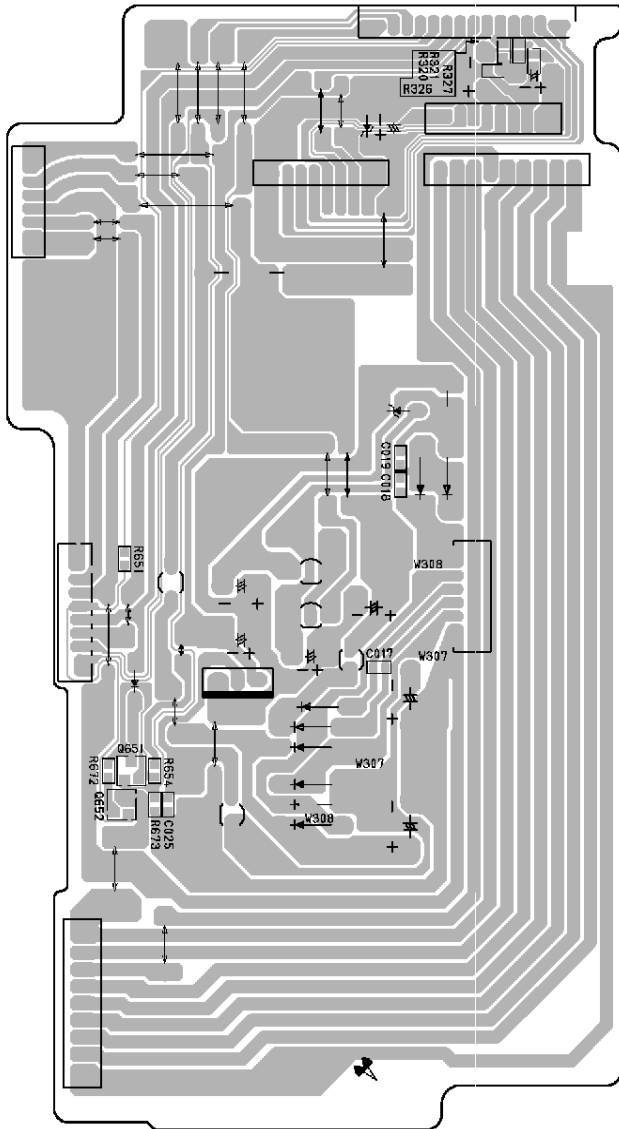

RECT PWB

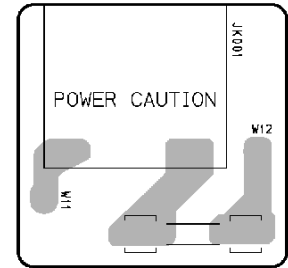

AC OUTLET (E) PWB

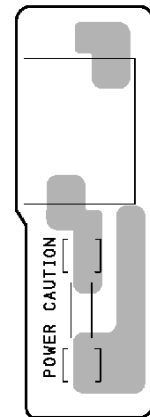

AC OUTLET (UC) PWB

Component Side

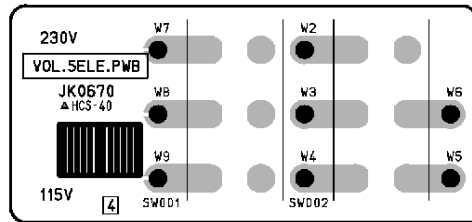

VOL SEL PWB

Soldering Side

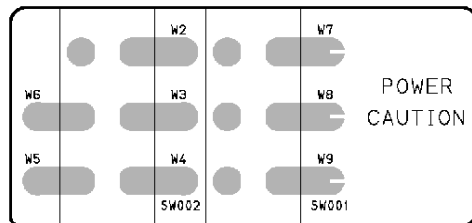

VOL SEL PWB

Soldering Side

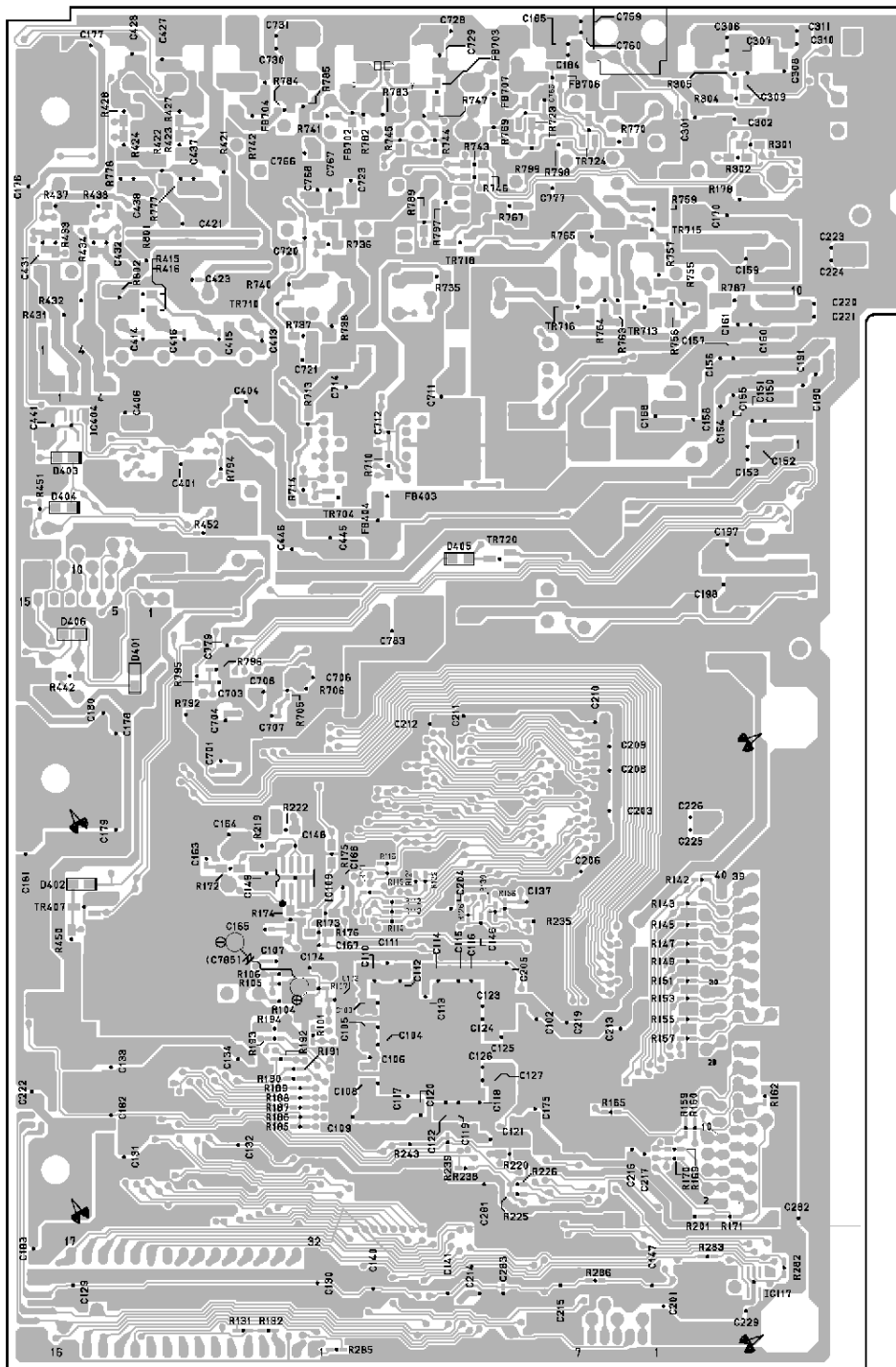

MAIN PWB

Component Side

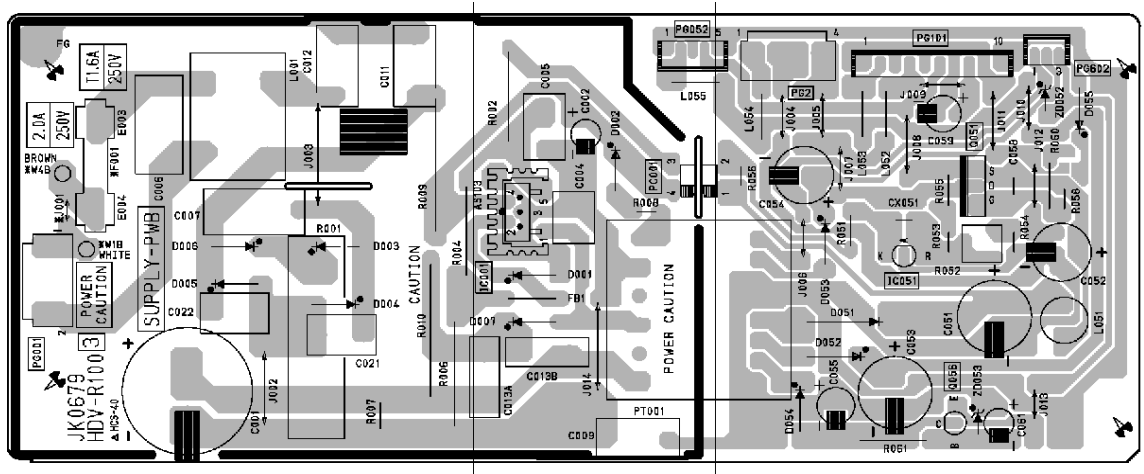

Soldering Side

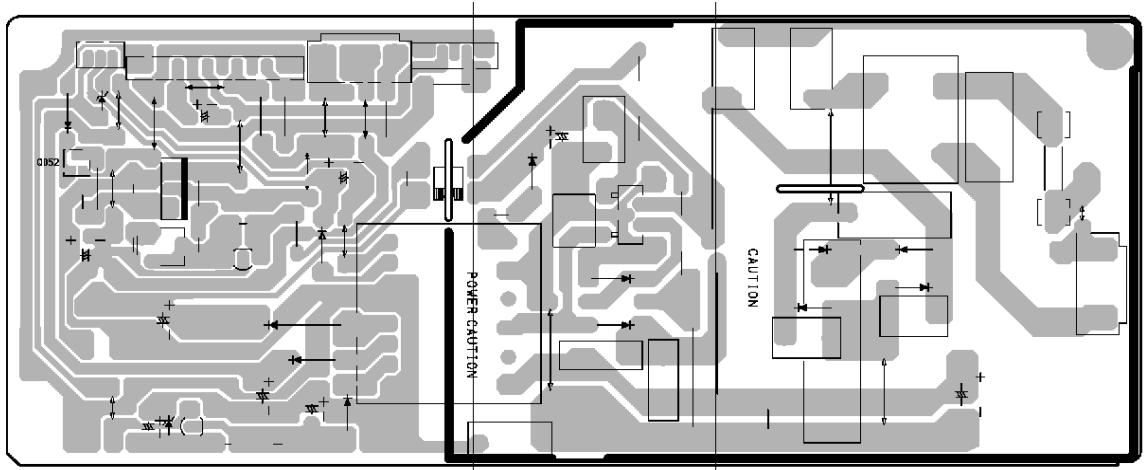

SUPPLY PWB

Component Side

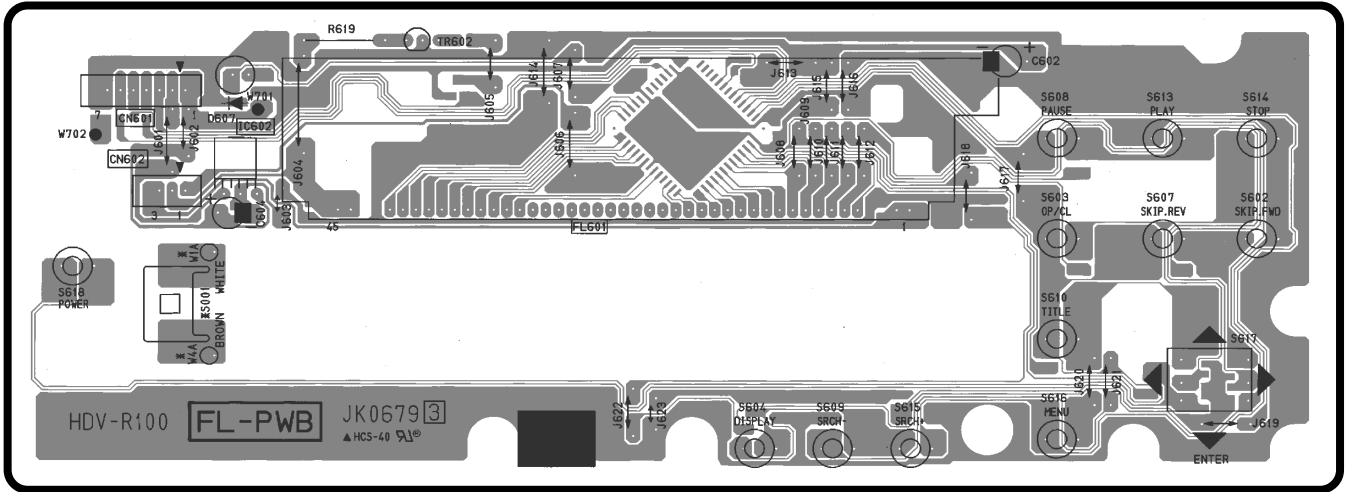

FL PWB

Soldering Side

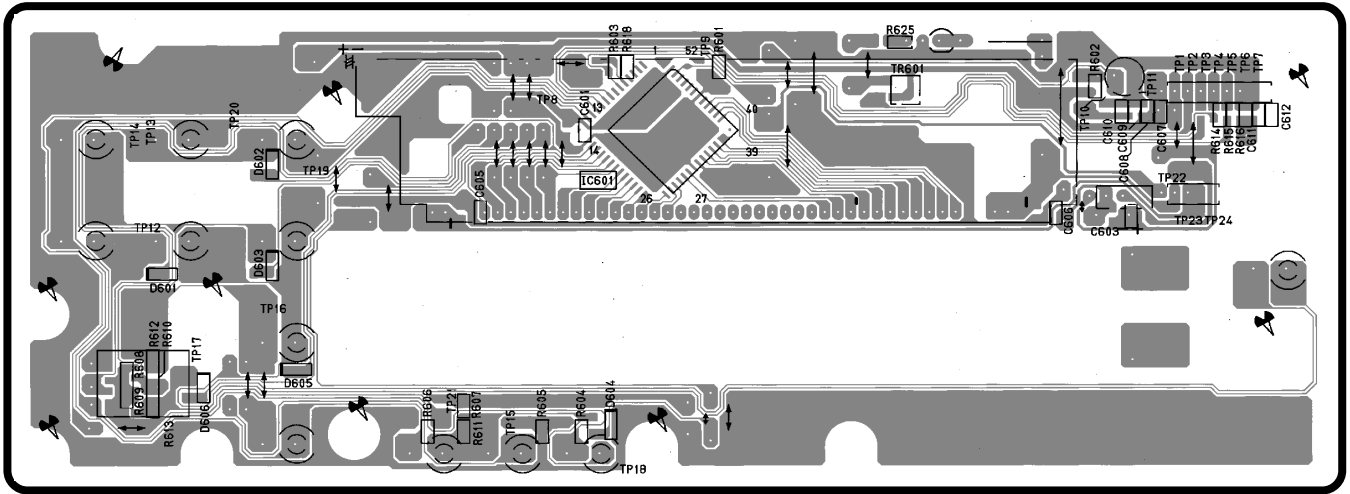

FL PWB

Component Side

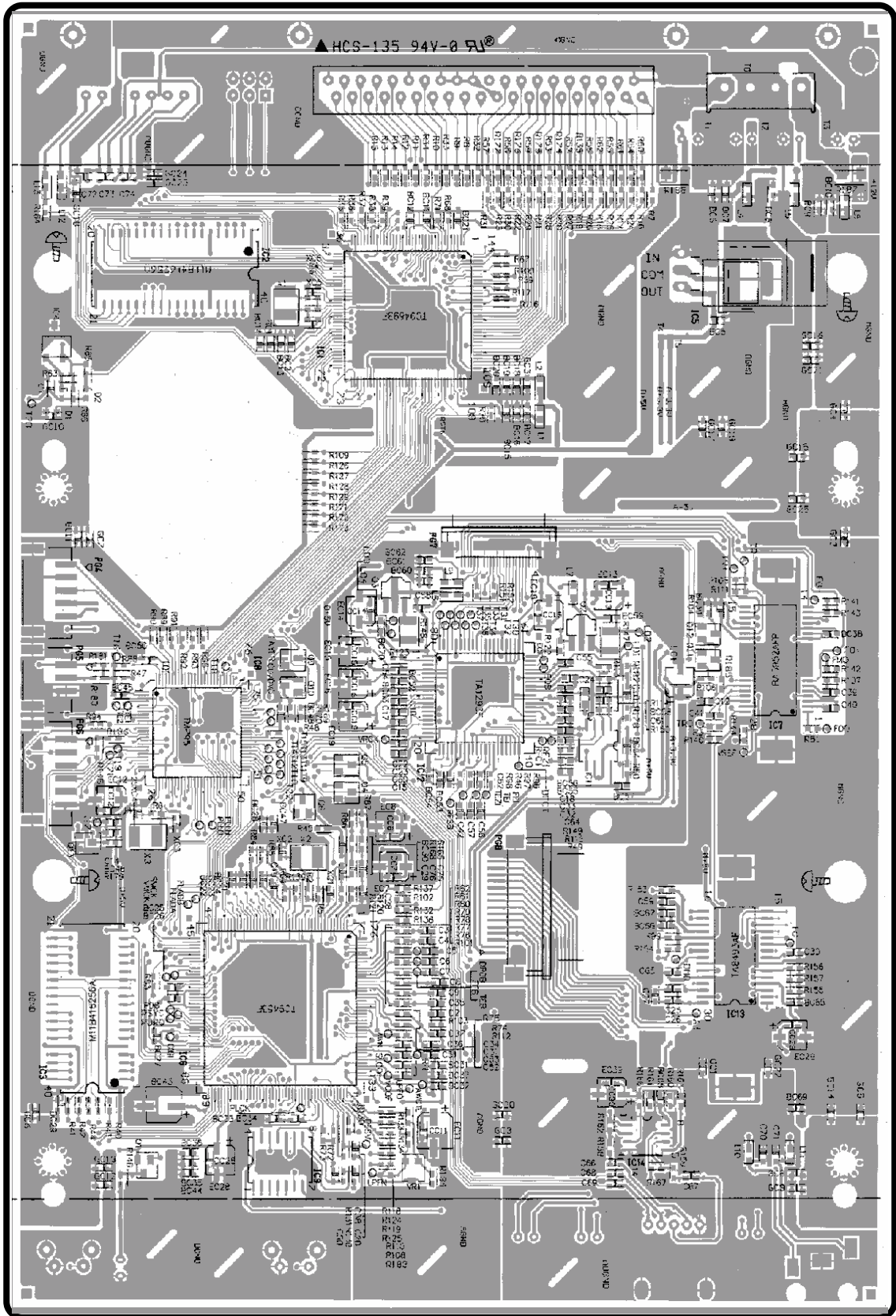

Soldering Side

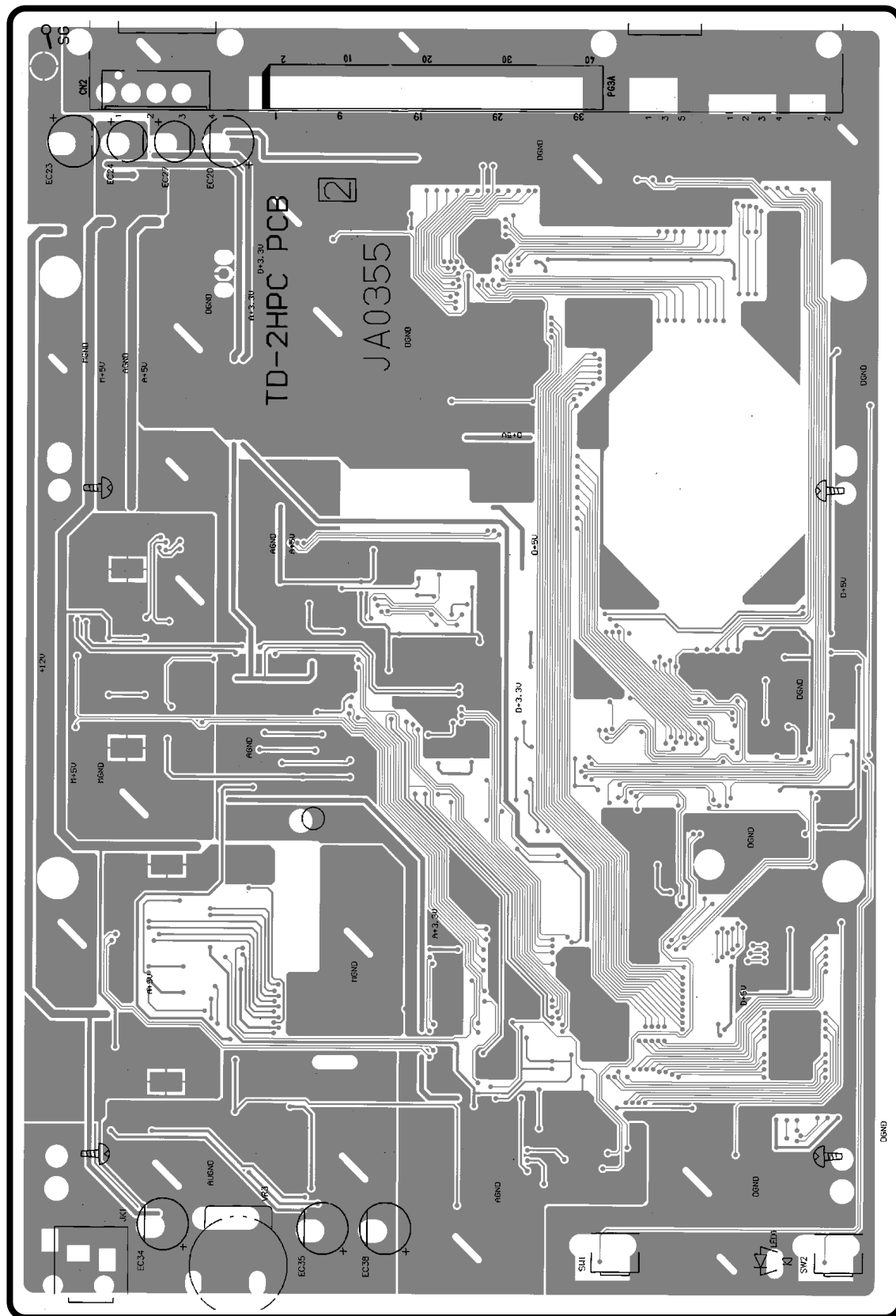

CIRCUIT DIAGRAM

DSP Circuit

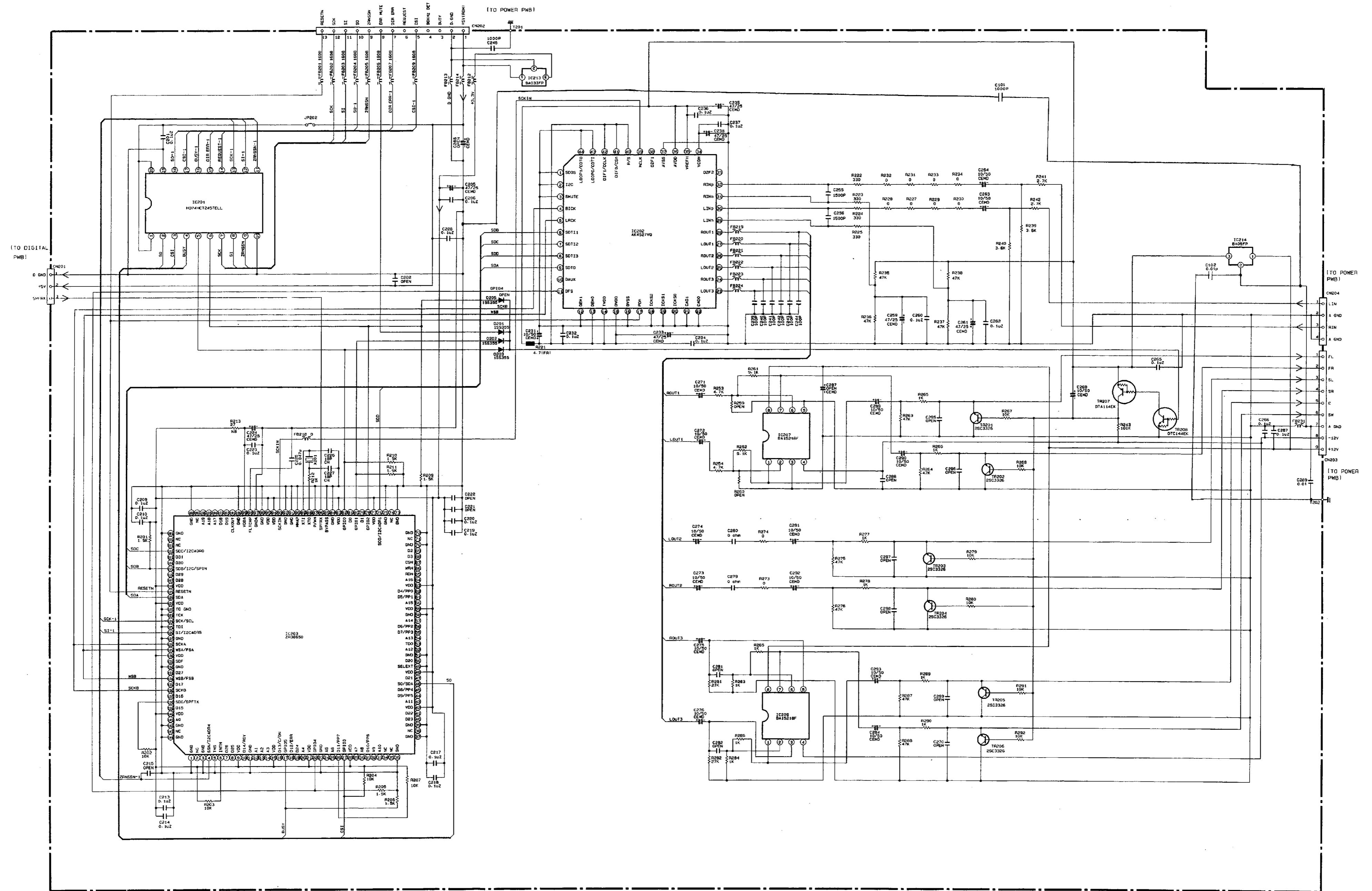

CIRCUIT DIAGRAM

PO/FL Circuit

THE DIFFERENCES ARE SHOWN IN TABLE BELOW:

	UC	E	EBS	W
F001	2.5A 250V	T1A 250V	T1A 250V	T1.6A 250V
F002	X	X	X	T800mA 250V
F003	X	T3.15A 250V	T3.15A 250V	X
F004	3A 250V	X	X	X
PT001	P#BT01772	P#BT01773	P#BT01773	P#BT01776
PT002	P#BT01412	P#BT01413	P#BT01413	P#BT01414
PR002	ICP-N26	ICP-N26	ICP-N26	ICP-N10
J001	O	O	O	X

for W.W(UK)only.

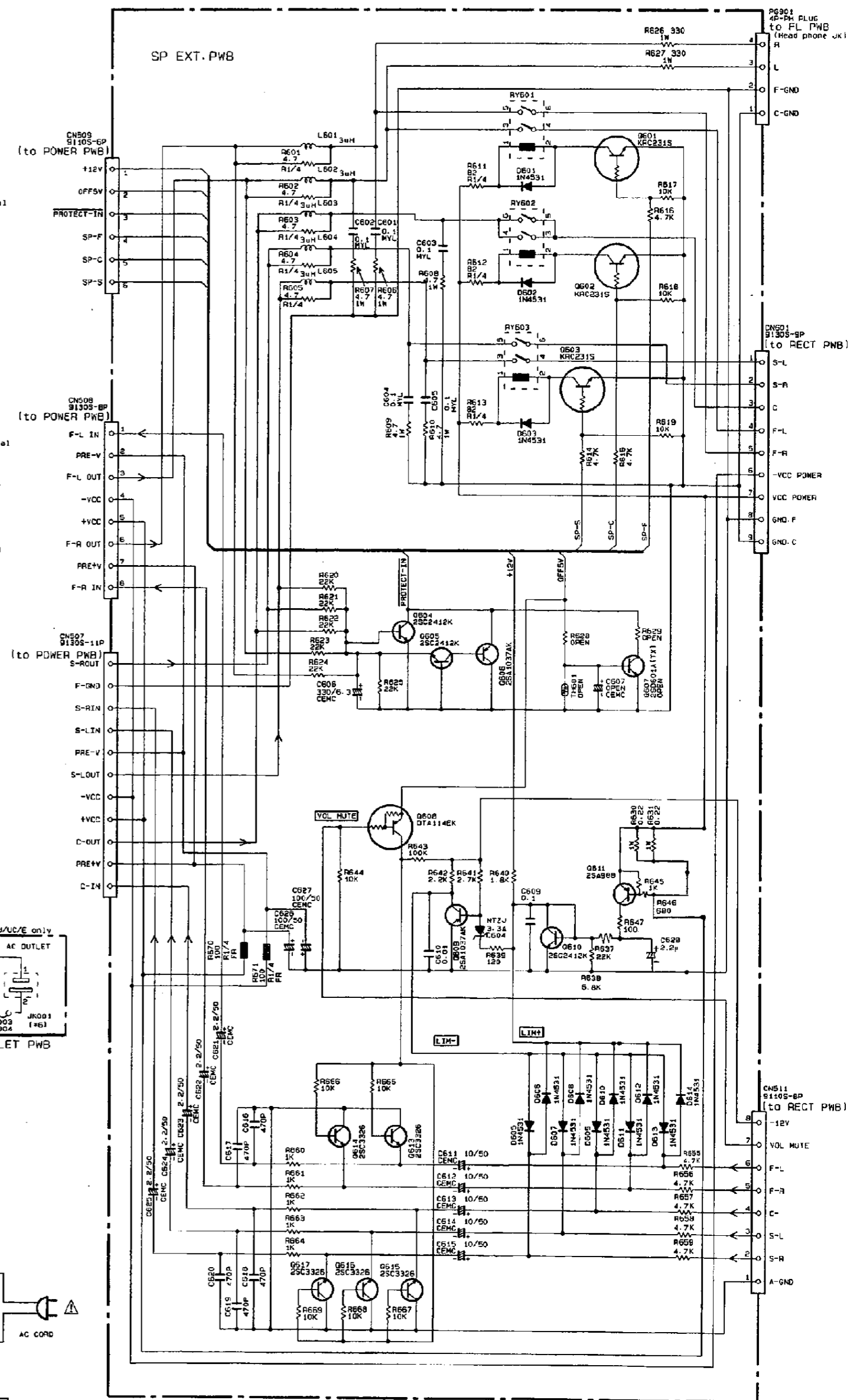
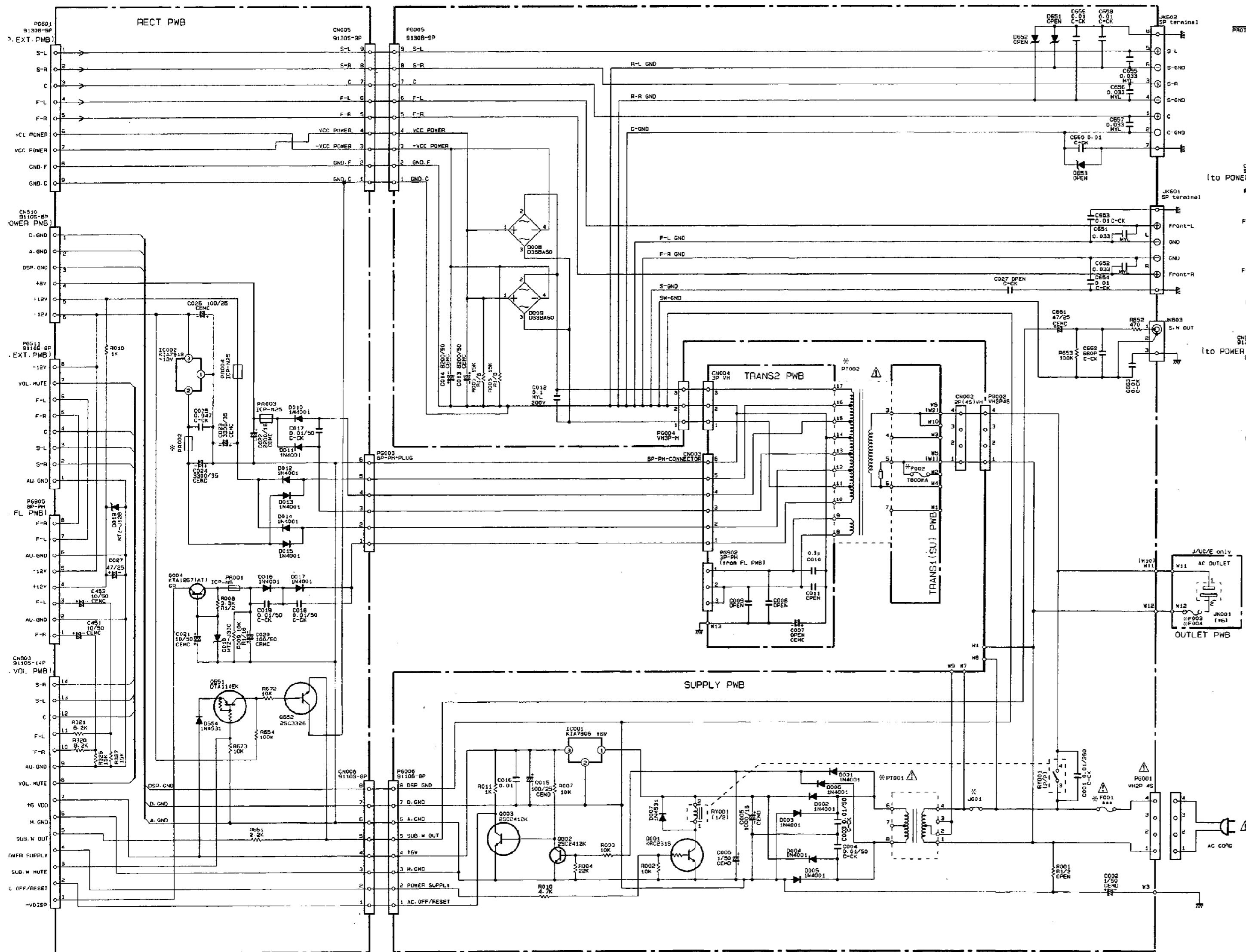
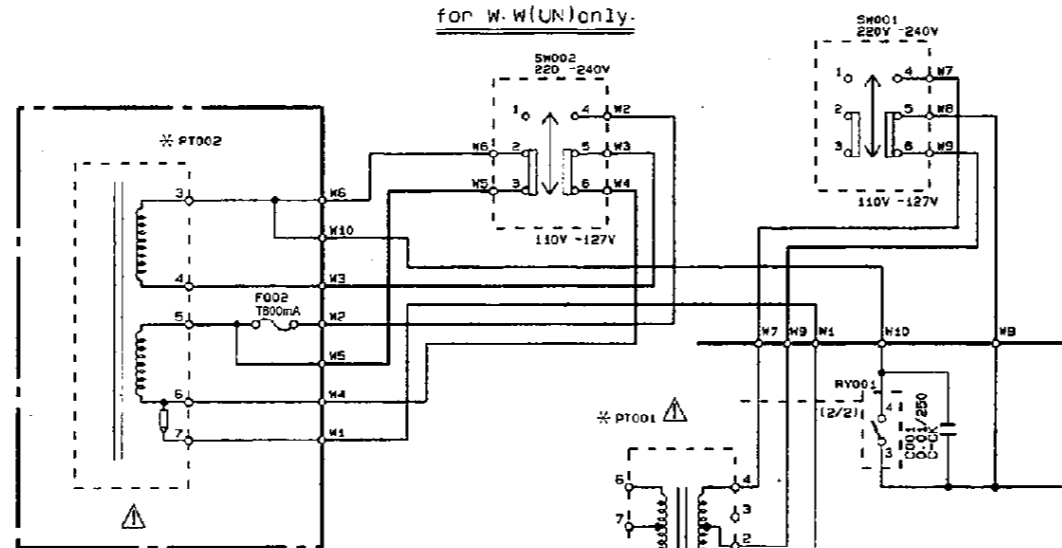

CIRCUIT DIAGRAM

TU-MAIN Circuit

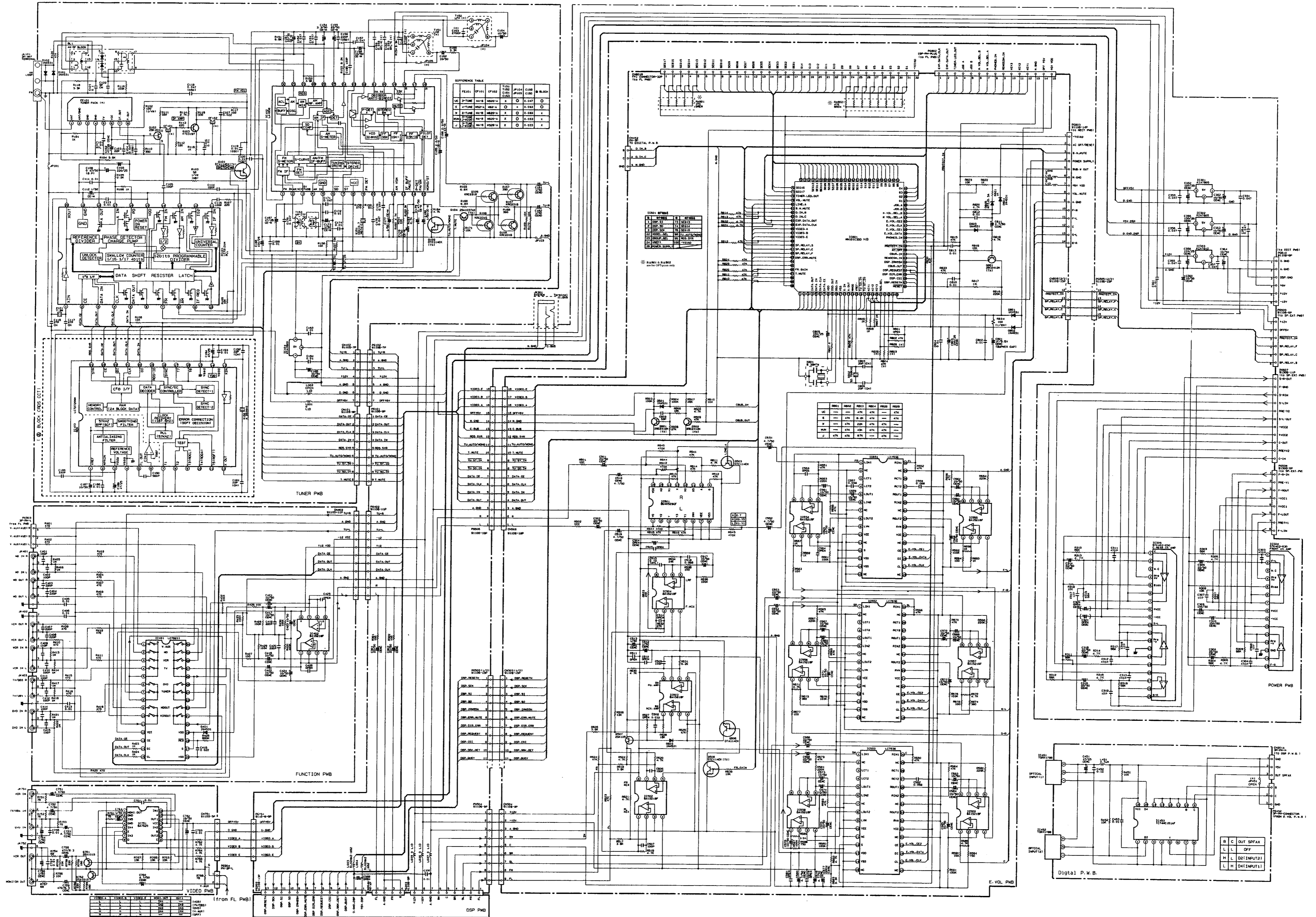

CIRCUIT DIAGRAM

MAIN Circuit

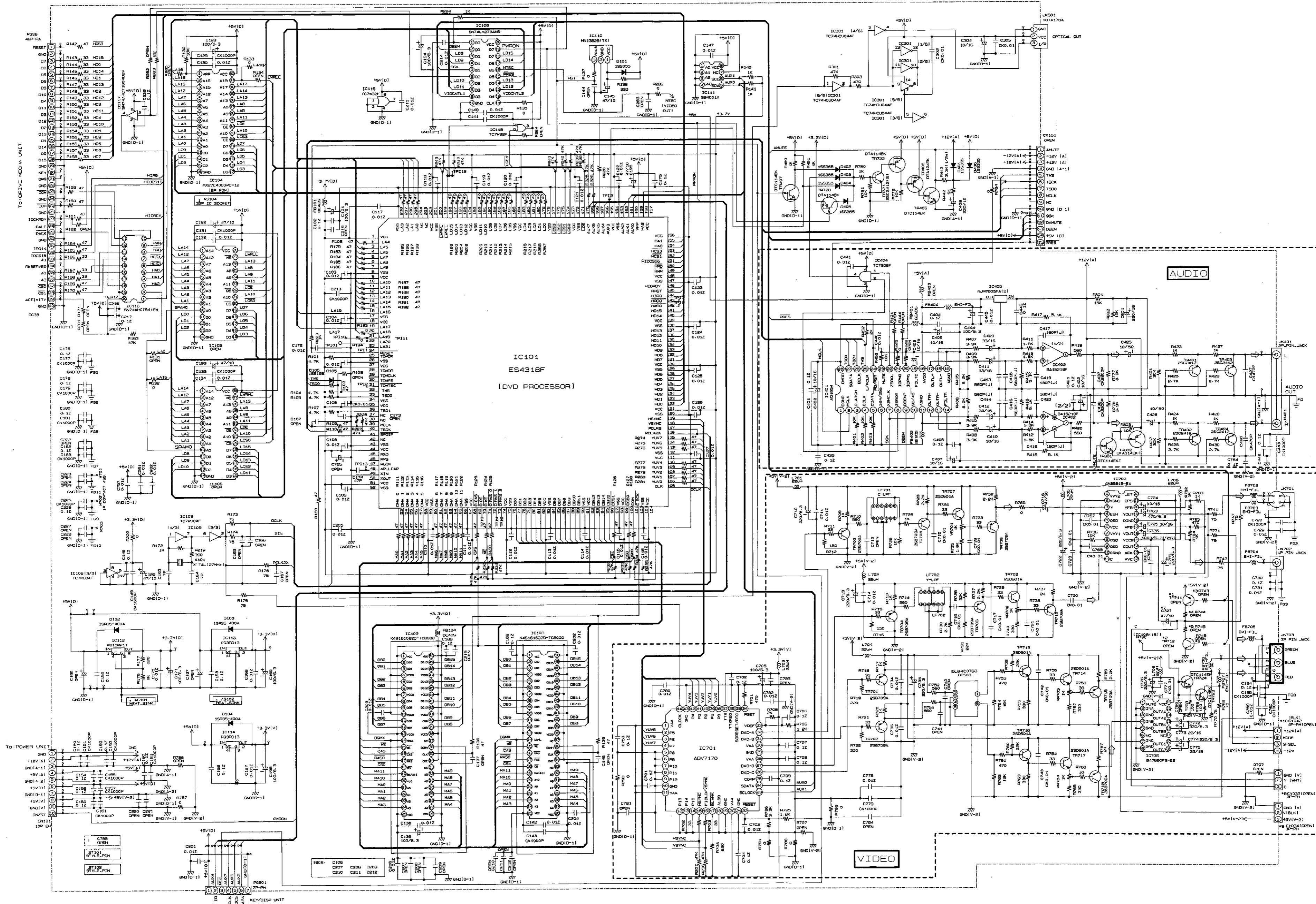

CIRCUIT DIAGRAM

SERVO Circuit (1)^{FEP}

TFEP2H.sch

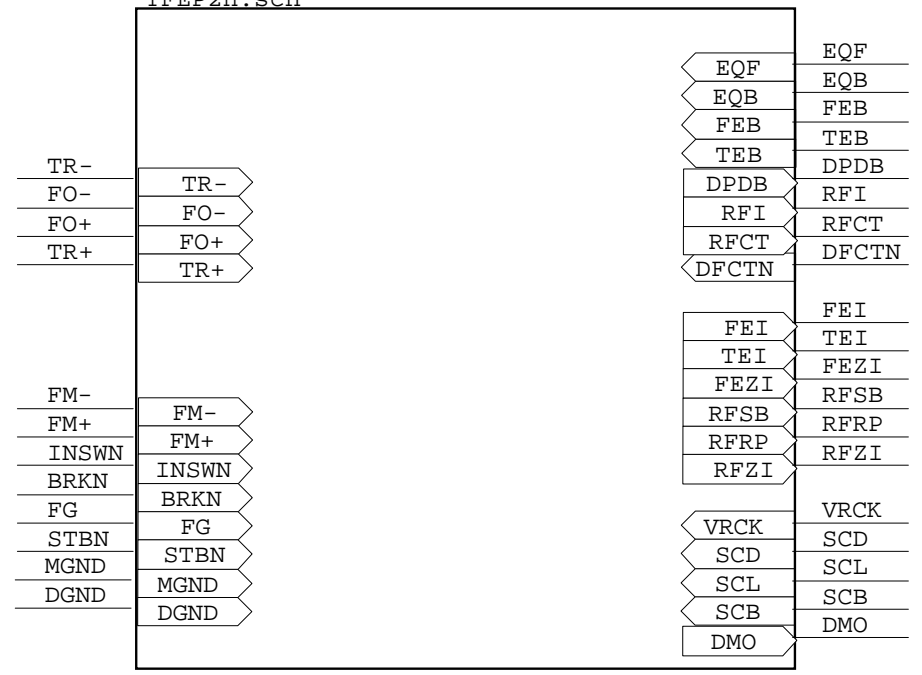

ATAPI
TATAPI2H.sch

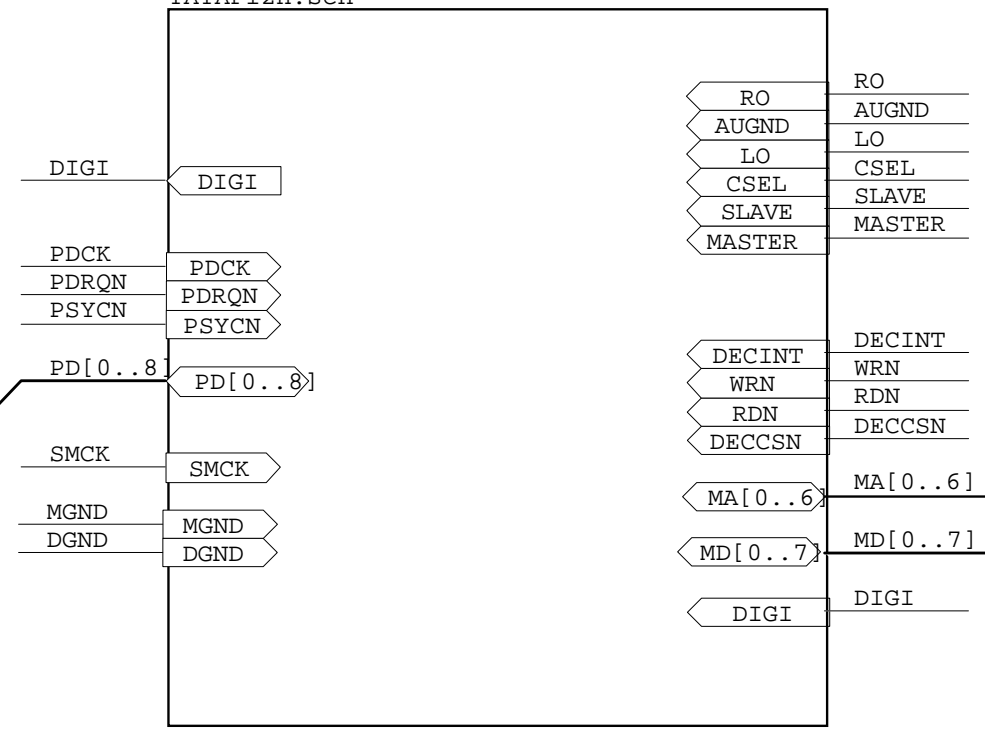

DSP
TDSP2H.sch

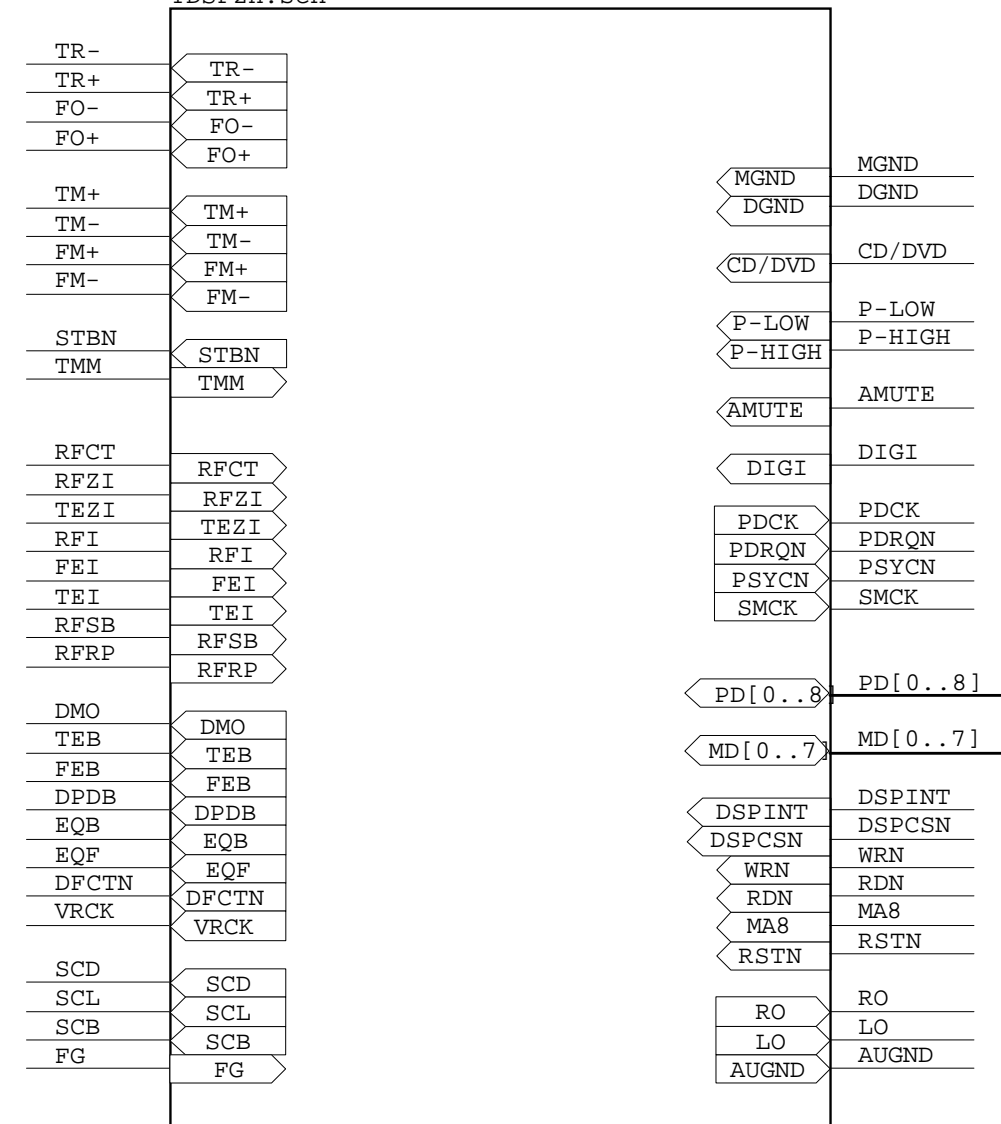

CPU
TCPU2H.sch

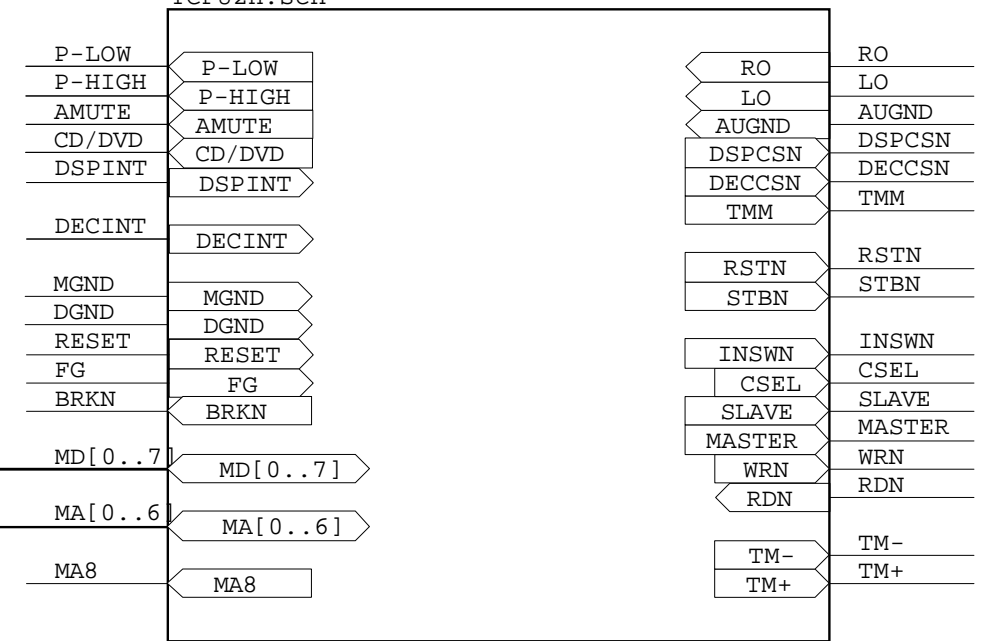

CIRCUIT DIAGRAM

SERVO Circuit (2)

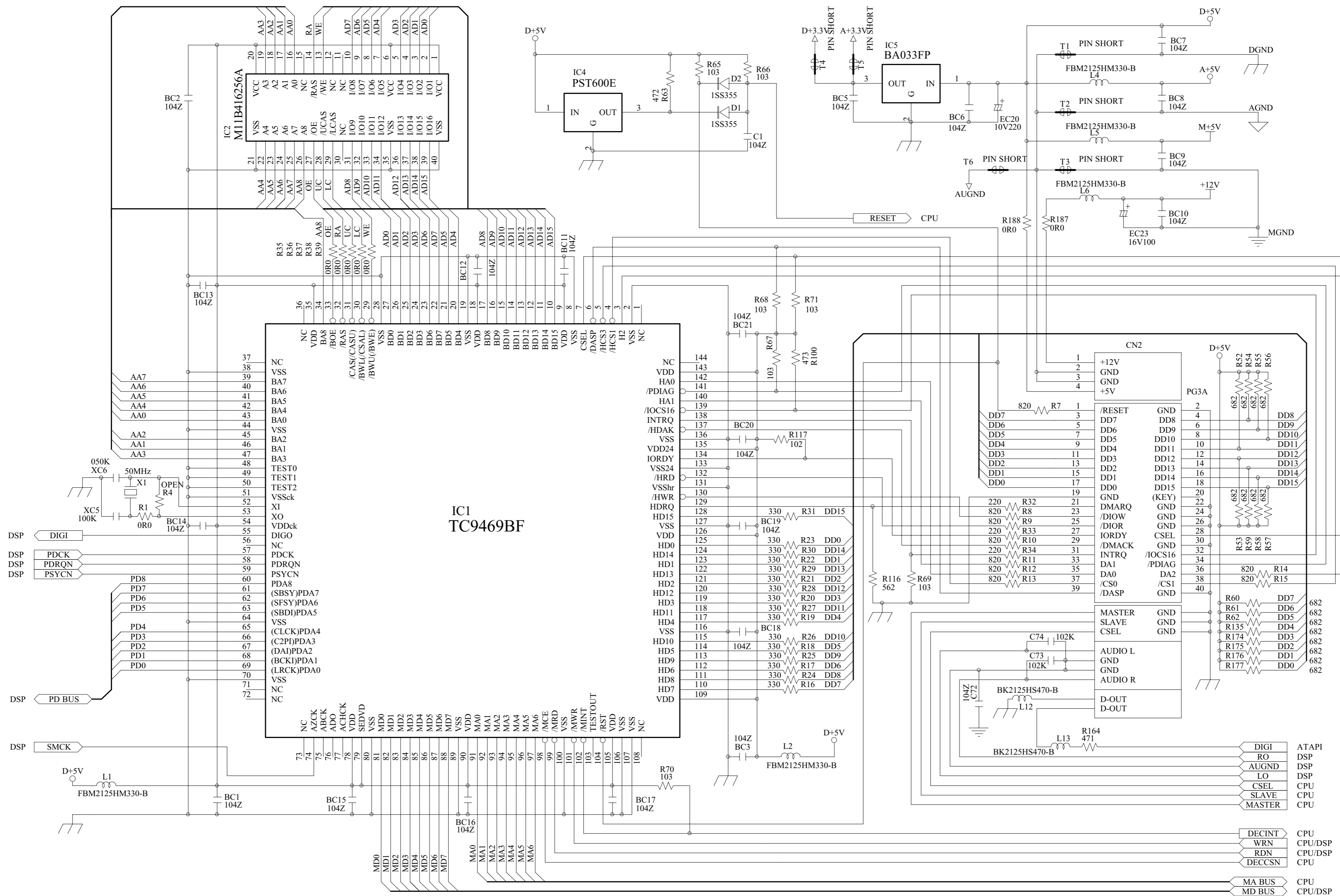

CIRCUIT DIAGRAM

SERVO Circuit (3)

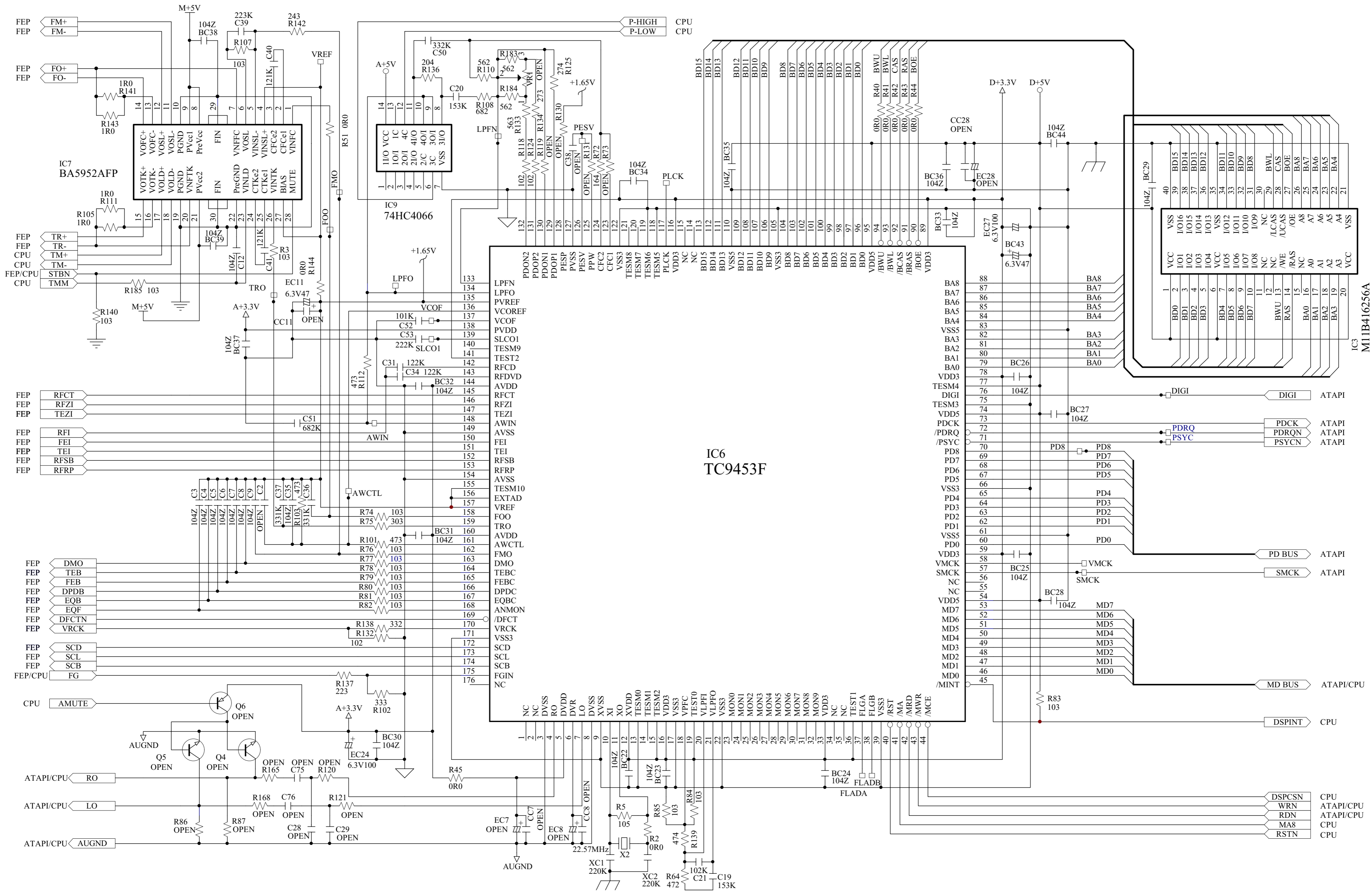

CIRCUIT DIAGRAM

SERVO Circuit (4)

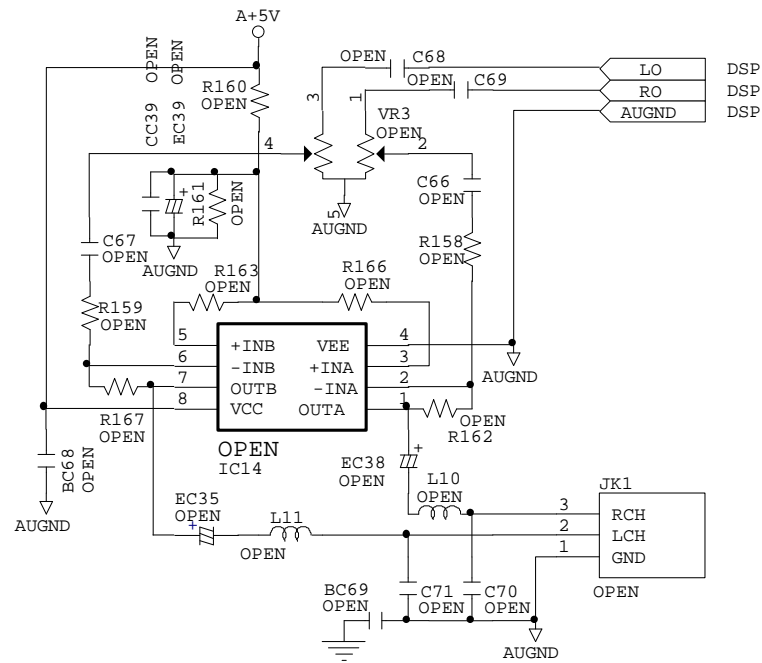
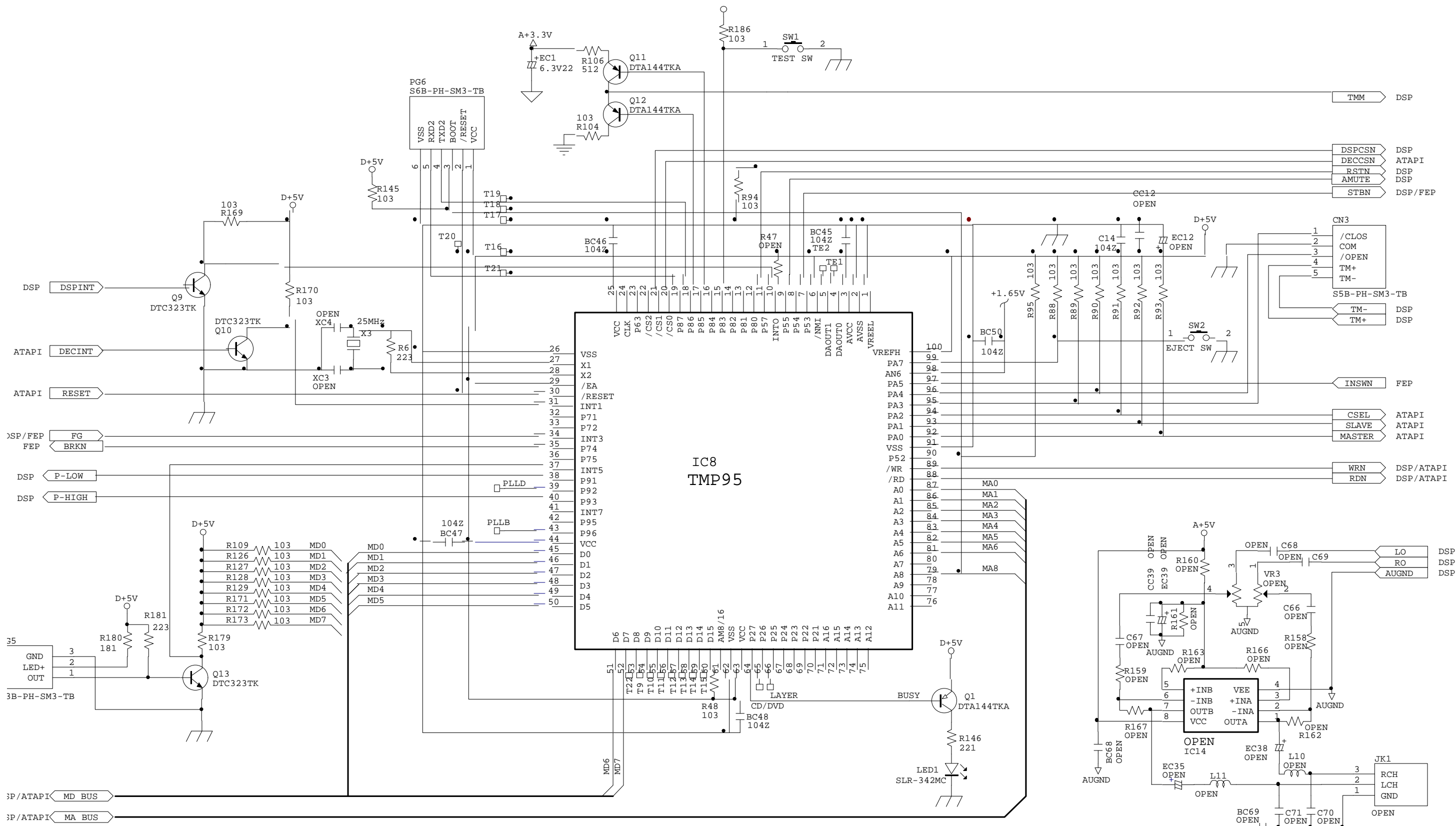

CIRCUIT DIAGRAM

SERVO Circuit (5)

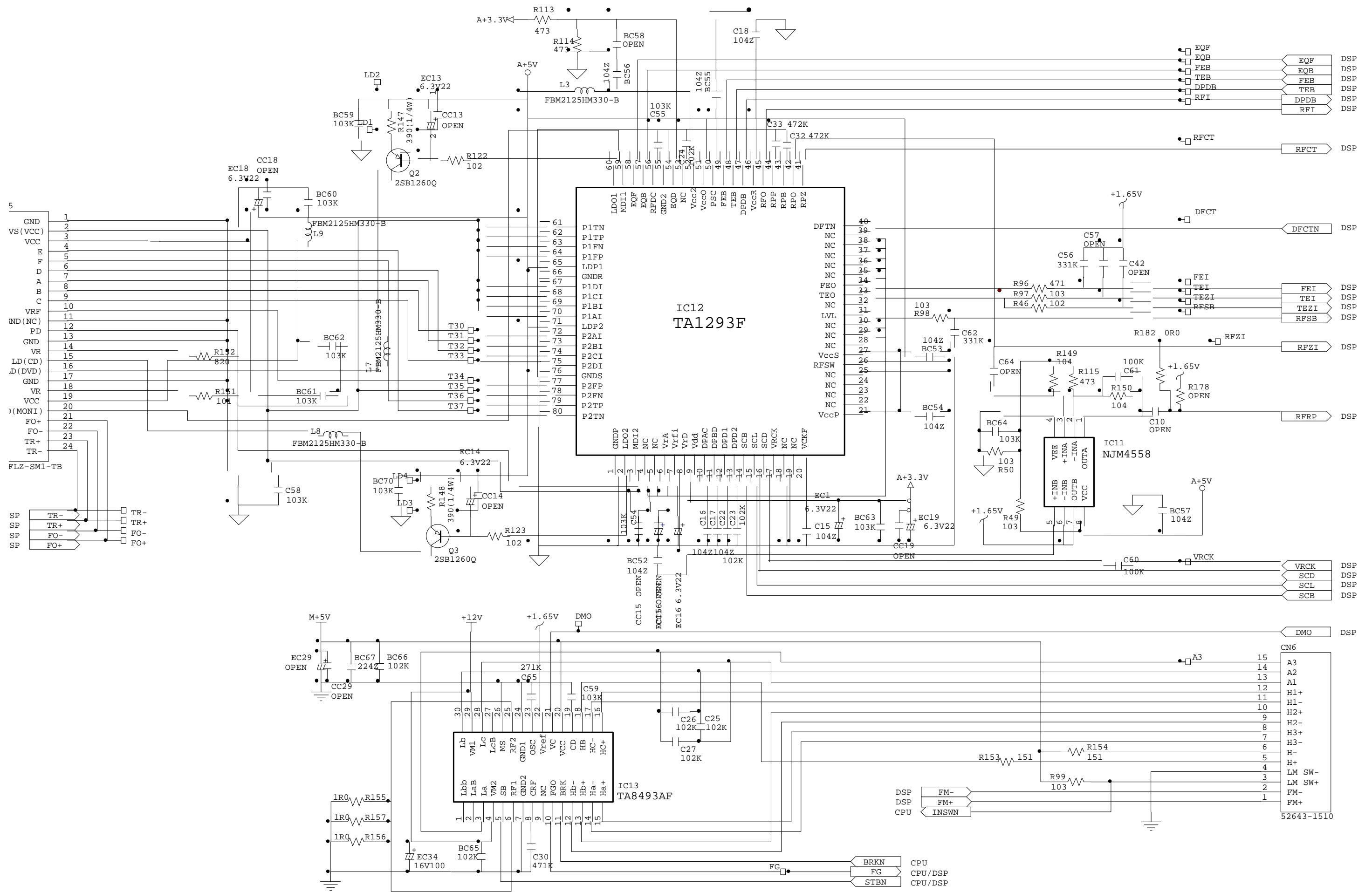

CIRCUIT DIAGRAM

FL SUPPLY Circuit

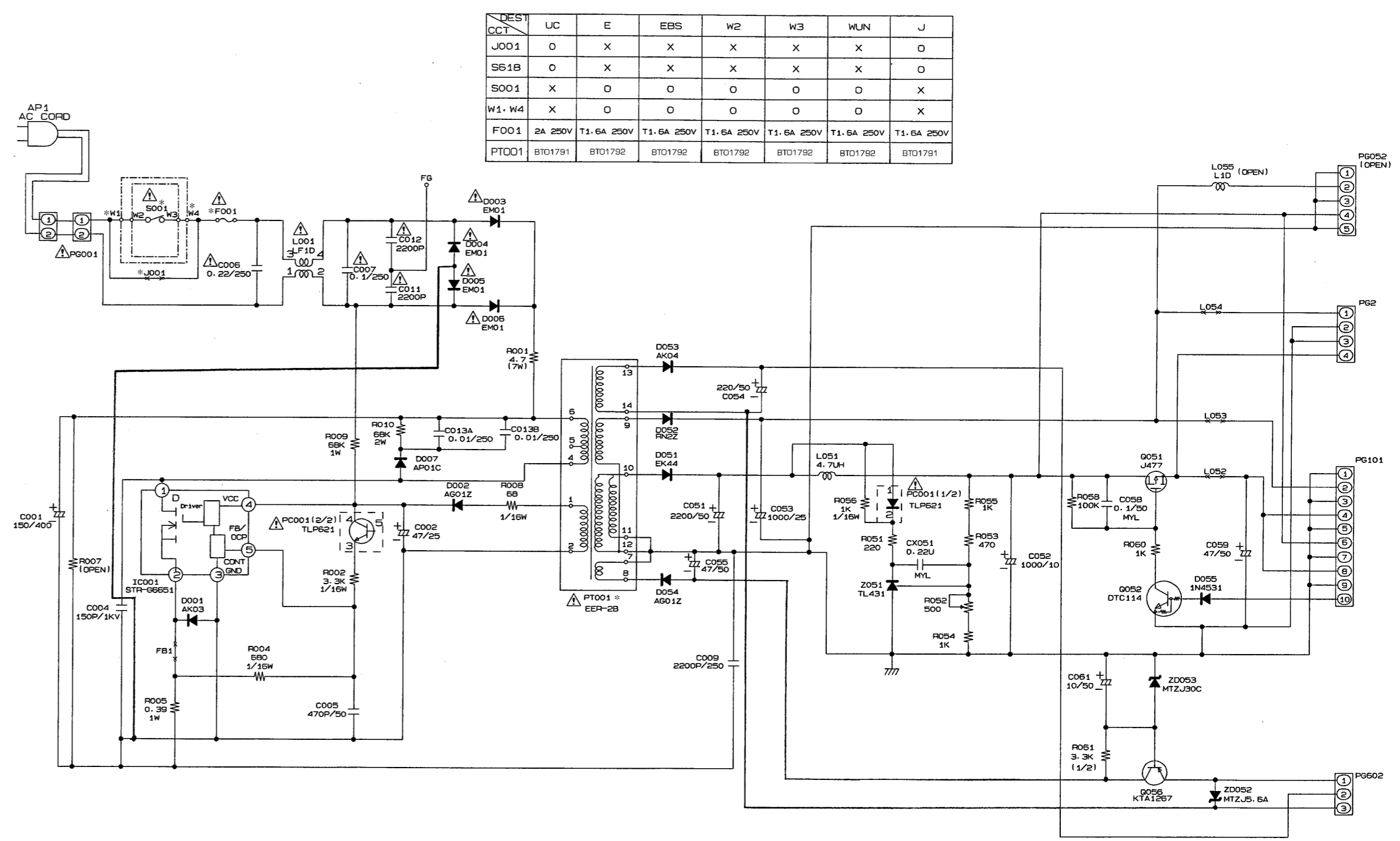
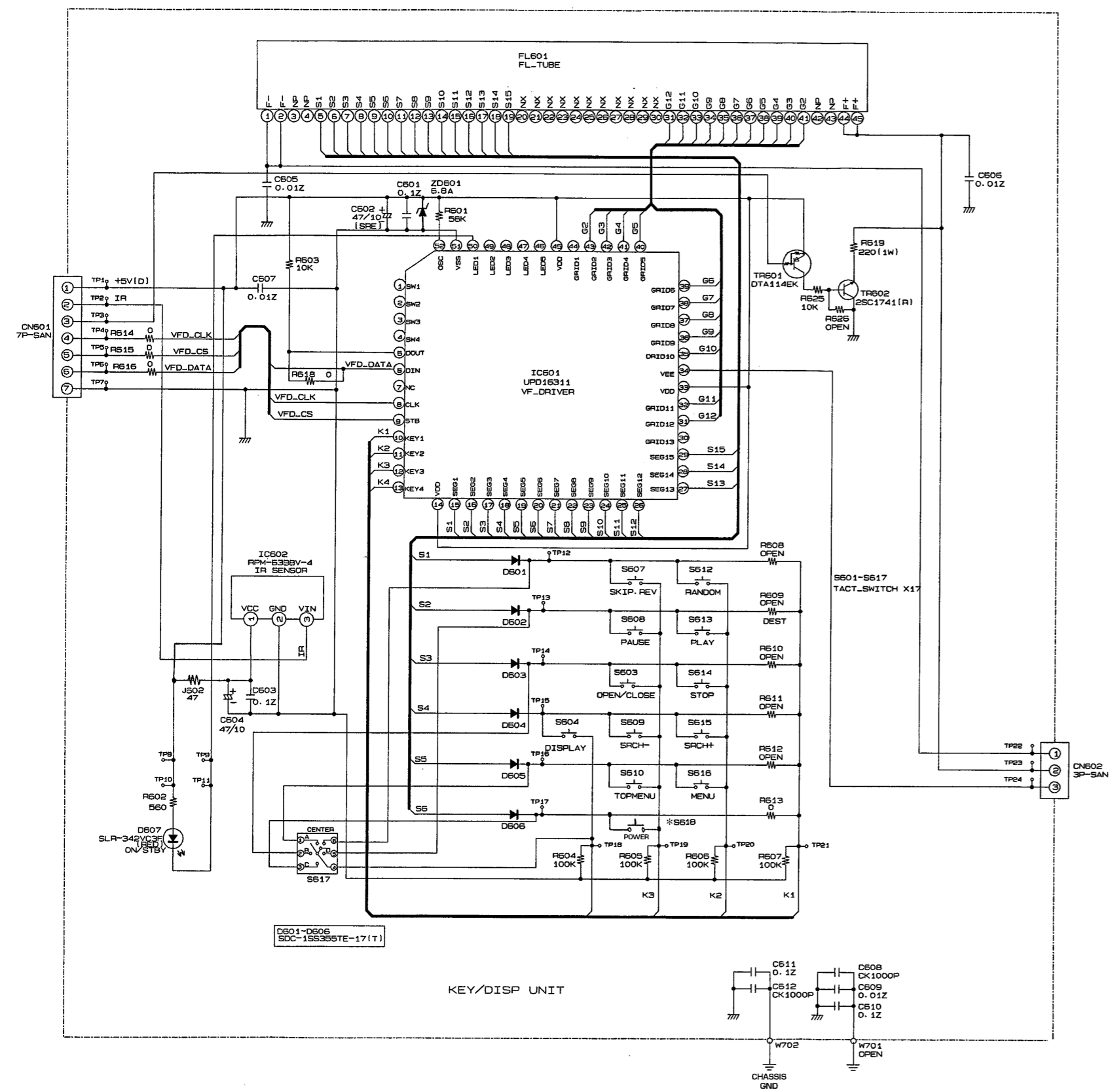

DES	UC	E	EBS	W2	W3	WUN	J
J001	0	X	X	X	X	X	0
S61B	0	X	X	X	X	X	0
S001	X	0	0	0	0	0	X
W1-W4	X	0	0	0	0	0	X
F001	2A 250V	T1.6A 250V	T1.6A 250V	T1.6A 250V	T1.6A 250V	T1.6A 250V	T1.6A 250V
PT001	BT01791	BT01792	BT01792	BT01792	BT01792	BT01792	BT01791

BLOCK DIAGRAM

• AV SURROUND RECEIVER (HTA-R150)

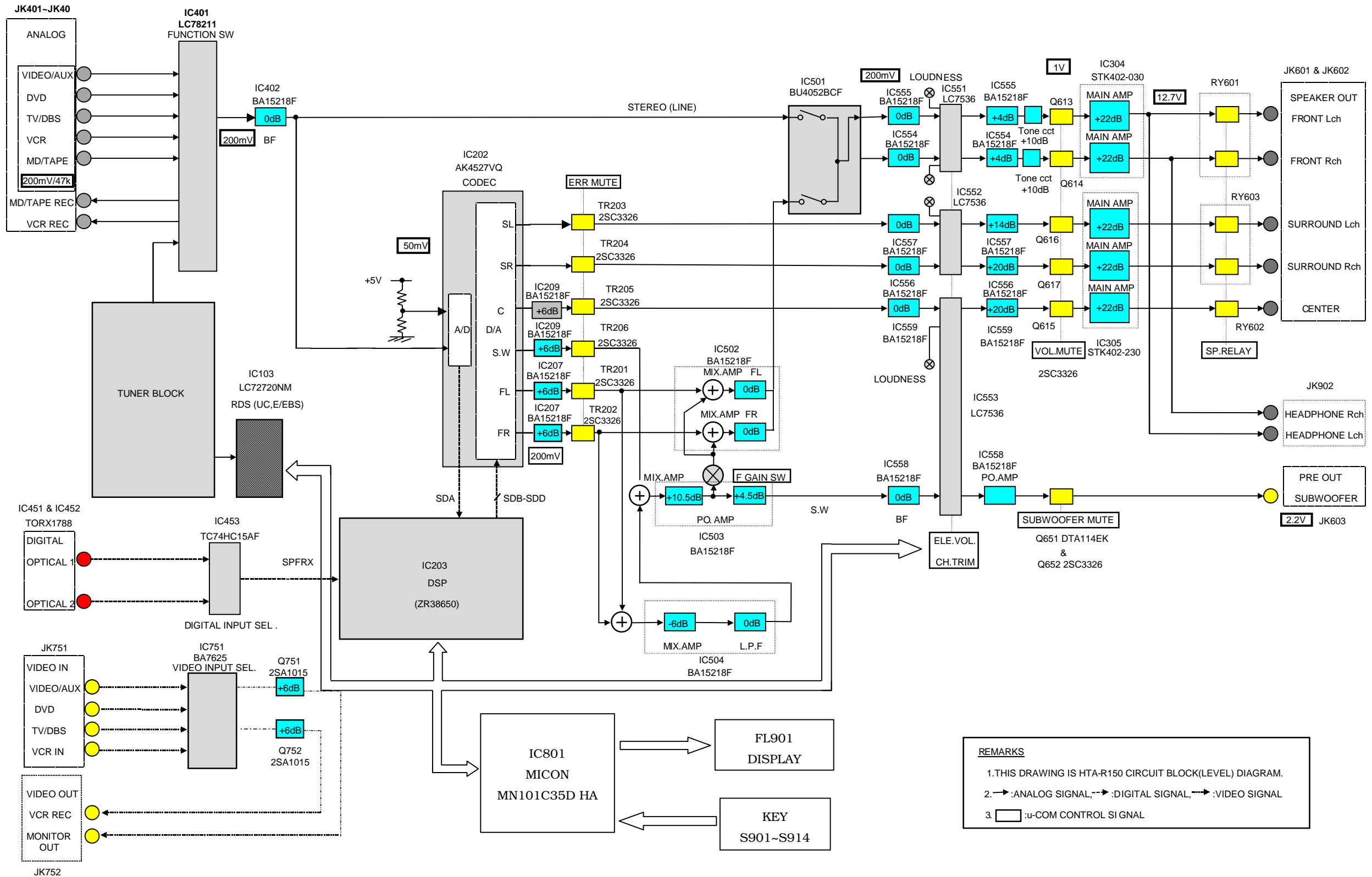

BLOCK DIAGRAM

• DVD/CD/VIDEO CD PLAYER (HDV-R100)

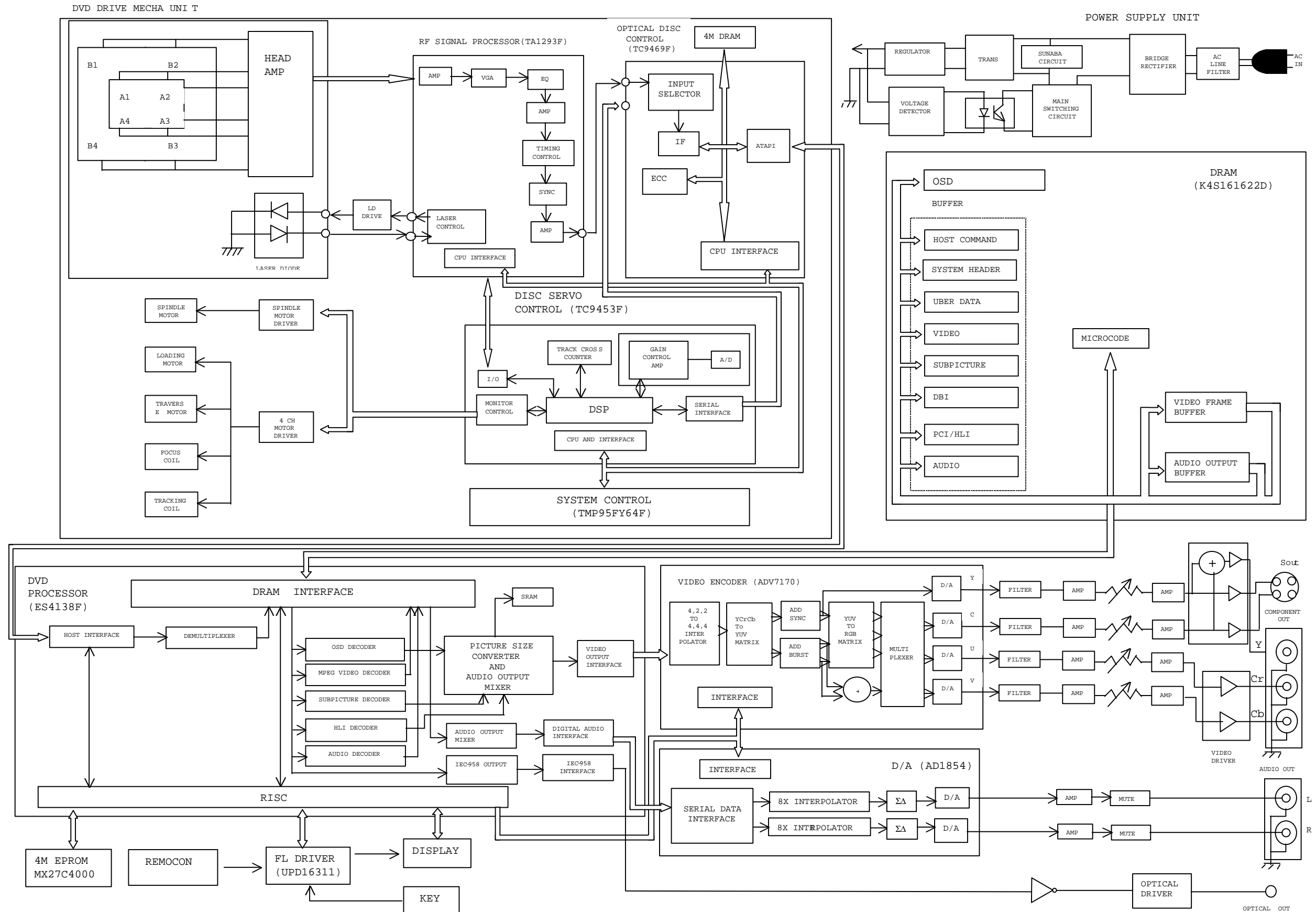

EXPLODED VIEWS

• AV SURROUND RECEIVER (HTA-R150)

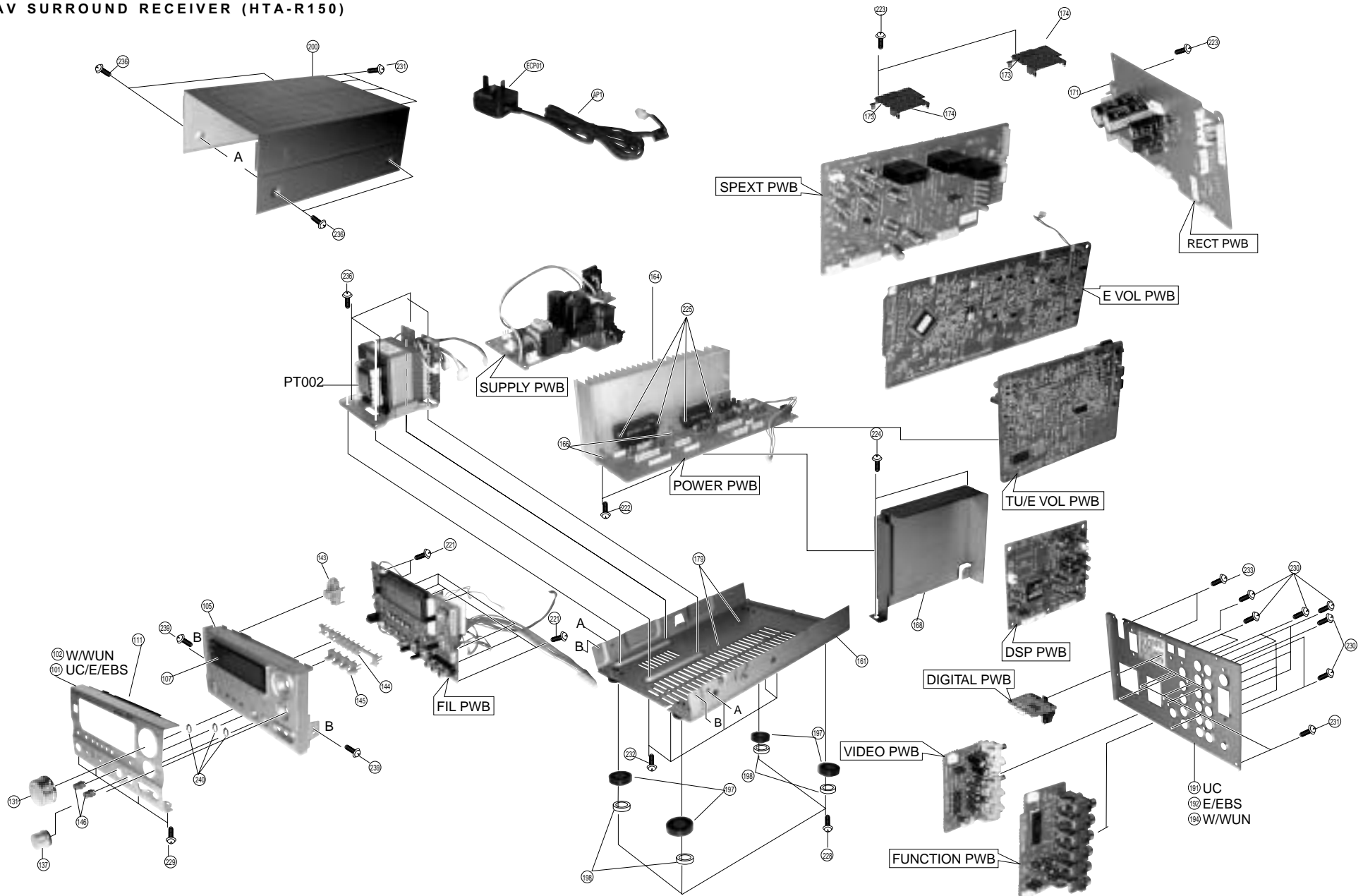

**THE UPDATED PARTS LIST
FOR THIS MODEL IS
AVAILABLE ON ESTA**

HITACHI

Hitachi, Ltd. Tokyo, Japan
International Sales Division
THE HITACHI ATAGO BUILDING,
No. 15-12 Nishi Shinbashi, 2-Chome,
Minato-Ku, Tokyo 105-8430, Japan.
Tel: 03 35022111

HITACHI EUROPE LTD,

Whitebrook Park
Lower Cookham Road
Maidenhead
Berkshire
SL6 8YA

UNITED KINGDOM

Tel: 01628 643000
Fax: 01628 643400
Email: consumer-service@hitachi-eu.com

HITACHI EUROPE S.A.

364 Kifissias Ave. & 1, Delfon Str.
152 33 Chalandri
Athens

GREECE

Tel: 1-6837200
Fax: 1-6835964
Email: service.hellas@hitachi-eu.com

HITACHI EUROPE GmbH

Munich Office
Dornacher Strasse 3
D-85622 Feldkirchen bei München

GERMANY

Tel: +49-89-991 80-0
Fax: +49-89-991 80-224
Hotline: +49-180-551 25 51 (12ct/min)
Email: HSE-DUS.service@hitachi-eu.com

HITACHI EUROPE S.A.

Gran Via Carlos III, 101-1
08028 Barcelona

SPAIN

Tel: 93 409 2550
Fax: 93 491 3513
Email: atencion.cliente@hitachi-eu.com

HITACHI EUROPE srl

Via Tommaso Gulli N.39, 20147
Milano, Italia

ITALY

Tel: +39 02 487861
Tel: +39 02 38073415 Servizio Clienti
Fax: +39 02 48786381/2
Email: customerservice.italy@hitachi-eu.com

HITACHI Europe AB

Box 77 S-164 94 Kista

SWEDEN

Tel: +46 (0) 8 562 711 00
Fax: +46 (0) 8 562 711 13
Email: csgswe@hitachi-eu.com

HITACHI EUROPE S.A.S

Lyon Office
B.P. 45, 69671 BRON CEDEX

FRANCE

Tel: 04 72 14 29 70
Fax: 04 72 14 29 99
Email: france.consommateur@hitachi-eu.com

HITACHI EUROPE LTD (Norway) AB

STRANDVEIEN 18

1366 Lysaker

NORWAY

Tel: 67 5190 30
Fax: 67 5190 32
Email: csgnor@hitachi-eu.com

HITACH EUROPE AB

Egebækgård
Egebækvej 98
DK-2850 Nærum

DENMARK

Tel: +45 43 43 6050
Fax: +45 43 60 51
Email: csgnor@hitachi-eu.com

HITACHI EUROPE AB

Neopoli / Niemenkatu 73
FIN-15140 Lahti

FINLAND

Tel : +358 3 8858 271
Fax: +358 3 8858 272
Email: csgnor@hitachi-eu.com

Hitachi Europe Ltd

Bergensesteenweg 421
1600 Sint-Pieters-Leeuw

BELGIUM

Tel: +32 2 363 99 01
Fax: +32 2 363 99 00
Email: sofie.van.bom@hitachi-eu.com

HITACHI EUROPE LTD

Na Sychrove 975/8
101 27 Praha 10 – Bohdalec

CZECH REPUBLIC

Tel: +420 267 212 383
Fax: +420 267 212 385
Email: csgnor@hitachi-eu.com