

HITACHI

SERVICE MANUAL

TY

No. 338 EGF

HGE-2100

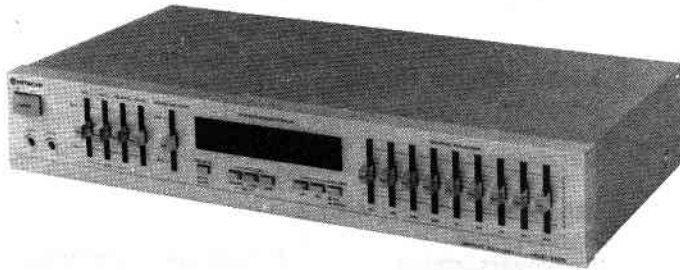

CONTENTS · INHALT · SOMMAIRE

SPECIFICATIONS · TECHNISCHE DATEN · SPECIFICATIONS	1, 2
FEATURES · MERKMALE · CARACTERISTIQUES	3
DISASSEMBLY AND REPLACEMENT · ZERLEGUNG UND AUSTAUSCHE · DEMONTAGE ET REMONTAGE	3
ADJUSTMENTS · EINSTELLVERFAHREN · RÉGLAGES	4
BLOCK DIAGRAM · BLOCKSCHEMA · SCHEMA	4
PRINTED WIRING BOARD · PRINTPLATTEN · PLAN DE BASE	5
CIRCUIT DIAGRAM · SCHALTPLAN · PLAN DE CIRCUIT	6
REPLACEMENT PARTS LIST · ERSATZTEILLISTE · TABLEAU DES PIECES	7
FRONT AND REAR PANEL · VORDERE UND HINTERE BEDIENUNGSTAFEL · PANNEAUX AVANT ET ARRIERE	11

SAFETY PRECAUTIONS

The following precautions should be observed when servicing.

1. Since many parts in the unit have special safety related characteristics, always use genuine Hitachi's replacement parts. Especially critical parts in the power circuit block should not be replaced with other makers. Critical parts are marked with Δ in the schematic diagram and circuit board diagram.
2. Before returning a repaired unit to the customer, the service technician must thoroughly test the unit to ascertain that it is completely safe to operate without danger of electrical shock.

SPECIFICATIONS

Input sensitivity/ Impedance	MIC 1 mV/8 kohms SOURCE/ TAPE 150 mV/47 kohms	Variable range of adjustment	± 10 dB
Rated output/ Impedance	150 mV/4 kohms	Echo time	variable 1 sec. – 4 sec.
Total harmonic distortion	0.05% (1V output)	Delay time	variable 20 msec. – 100 msec.
Frequency response	20 Hz – 20 kHz ± 2 dB	MIC jacks	2
Signal-to-noise ratio	70 dB (150 mV input)	Tape systems	1
Equalizer center frequencies	9 elements 63 Hz, 125 Hz, 250 Hz, 500 Hz, 1 kHz, 2 kHz, 4 kHz, 8 kHz, 16 kHz	Power supply voltage	AC 120V 60 Hz, ~ 220V 50 Hz, ~ 240V 50 Hz, 110-120V / 220-240V 50/60 Hz
		Power consumption	10W
		Dimensions	435 (W) x 83 (H) x 225 (D) mm
		Weight	3 kg

* All specifications for this unit apply with a flat equalization.

SPECIFICATIONS AND PARTS ARE SUBJECT TO CHANGE FOR IMPROVEMENT.

GRAPHIC EQUALIZER

July 1982 TOYOKAWA WORKS

SICHERHEITSMASSNAHMEN

Bei Wartungsarbeiten sind die folgenden Sicherheitsmaßnahmen zu beachten:

1. Da verschiedene Teile dieses Gerätes Sicherheitsfunktionen aufweisen, nur Original-Hitachi-Ersatzteile verwenden. Kritische Teile im Netzteil sollten nicht durch ähnliche Teile anderer Hersteller ersetzt werden. Alle kritischen Teile sind im Schaltplan und im Diagramm der Schaltplatinen mit dem Symbol Δ gekennzeichnet.
2. Vor der Auslieferung eines reparierten Gerätes an den Kunden muß der Wartungstechniker das Gerät einer gründlichen Prüfung unterziehen, um sicherzustellen, daß sicherer Betrieb ohne die Gefahr von elektrischen Schlägen gewährleistet ist.

TECHNISCHE DATEN

Eingangsempfindlichkeit/Impedanz	MIC 1 mV/8 kOhm SOURCE/ TAPE 150 mV/47 kOhm
Nennausgangsleistung/Impedanz	150 mV/4 kOhm
Klirrfaktor	0,05% (1V Ausgang)
Frequenzgang	20 Hz - 20 kHz \pm 2 dB
Geräuschspannungsabstand	70 dB (150 mV Eingang)
Entzerrer-Mittelfrequenzen	9 Elemente 63 Hz, 125 Hz, 250 Hz, 500 Hz, 1 kHz, 2 kHz, 4 kHz, 8 kHz, 16 kHz

Veränderlicher Einstellbereich	\pm 10 dB
Echozeit	veränderlich 1 Sek. - 4 Sek.
Verzögerungszeit	veränderlich 20 mSek. - 100 mSek.
Mikrofonbuchsen (MIC)	2
Bandsystem	1
Stromversorgung	~120V 60 Hz, ~220V 50 Hz, ~240V 50 Hz, ~110-120V/ 220-240V, 50/60 Hz
Leistungsaufnahme	10W
Tabmessungen	435 (B) x 83 (H) x 225 (T) mm
Gewicht	3 kg

* Bei allen technischen Daten dieses Gerätes handelt es sich um Werte bei linearer Entzerrung.

PRÉCAUTIONS DE SÉCURITÉ

Les précautions suivantes doivent être observées chaque fois qu'une réparation doit être faite.

1. Étant donné que de nombreux composants de l'appareil possèdent des caractéristiques relatives à la sécurité, utiliser uniquement des pièces de rechange d'origine Hitachi pour effectuer un remplacement. Ceci se rapporte notamment aux pièces critiques du bloc d'alimentation qui ne doivent en aucun cas être remplacées par celles d'autres fabricants. Les pièces critiques sont accompagnées du symbole Δ dans le schéma de montage et sur le schéma de plaque de câblage.
2. Avant de retourner l'appareil réparé au client, le technicien doit procéder à un essai complet pour s'assurer qu'il ne présente aucun danger de chocs électriques.

SPECIFICATIONS

Sensibilité d'entrée/impédance	MIC 1 mV/8 kohms SOURCE/ TAPE 150 mV/47 kohms
Sortie nominale/impédance	150 mV/4 kohms
Distortion harmonique totale	0,05% (1V sortie)
Réponse en fréquence	20 Hz - 20 kHz \pm 2 dB
Rapport signal/bruit	70 dB (150 mV entrée)
Fréquences centrales d'égalisation	9 gammes 63 Hz, 125 Hz, 250 Hz, 500 Hz, 1 kHz, 2 kHz, 4 kHz, 8 kHz, 16 kHz

Réglage de gamme variable	\pm 10 dB
Durée de l'écho	variable 1 sec. - 4 sec.
Retardement	variable 20 msec. - 100 msec.
Entrées MIC	2
Types de bande	1
Tension d'alimentation	~120V 60 Hz, ~220V 50 Hz, ~240V 50 Hz, 110-120V/220-240V 50/60 Hz
Consommation	10W
Dimensions	435 (L) x 83 (H) x 225 (P) mm
Poids	3 kg

* Toutes les spécifications de cet appareil sont données pour une égalisation plate.

FEATURES · MERKMALE · CARACTERISTIQUES

1. The audio frequency spectrum is divided into 9 bands in steps of 1 octave with 1 kHz as the basic central frequency.
2. Large dynamic range semiconductor inductors are used in the resonance circuits.
3. Built-in electronic echo circuit

4. Convenient equalizer selector switches
5. Two microphone inputs. Microphone mixing recording possible.
6. Mixing balance adjustment provides continuous variation of mixing ratio.

1. Der Audio-Frequenzumfang ist in 9 Bereiche in Schritten von 1 Oktave mit 1 kHz als Grundmittenfrequenz eingeteilt.
2. In den Resonanzschaltungen werden Halbleiter verwendet, die einen großen Dynamikbereich aufweisen.
3. Eingebaute elektronische Echoschaltung

4. Leicht zu bedienende Entzerrungswahlschalter
5. Zwei Mikrofoneingänge. Mikrofonmischaufnahmen sind möglich.
6. Die Mischbalance-Einstellung gewährleistet ständige Veränderungen des Mischverhältnisses.

1. Le spectre des fréquences audio est divisé en 9 gammes, par étape de 1 octave sur une fréquence centrale de base de 1 kHz.
2. Des inducteurs pour semiconducteur à gamme dynamique large sont incorporés aux circuits de résonance.
3. Circuit d'écho électronique incorporé

4. Sélecteurs d'égalisation à accès pratique
5. Deux entrées pour microphone. Possibilité d'enregistrement avec mixage microphone.
6. Le réglage d'équilibre de mixage permet d'obtenir une variation continue du rapport de mixage.

DISASSEMBLY AND REPLACEMENT · ZERLEGUNG UND AUSTAUSCHE · DEMONTAGE ET REMONTAGE

- Removing the printed wiring boards
- Ausbau der Leiterplatten
- Dépose des plaquettes à circuit imprimé

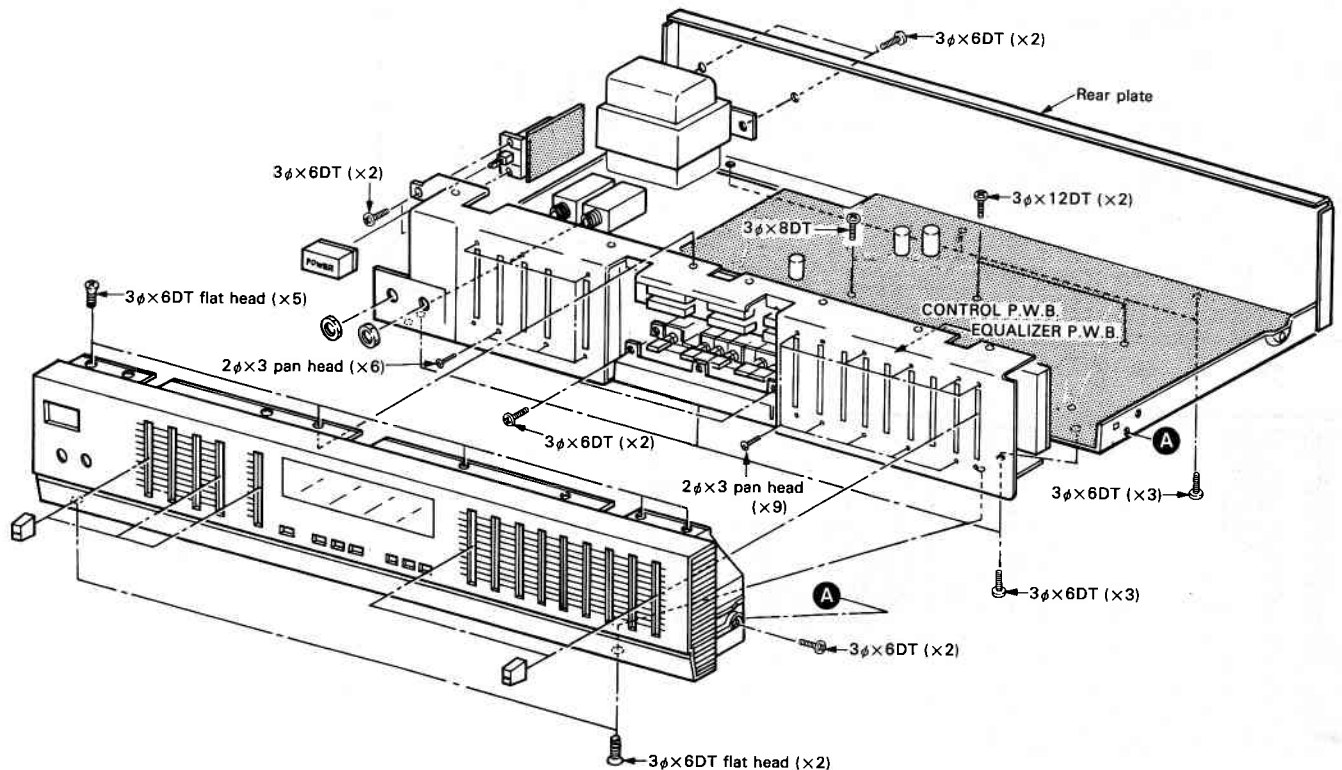

Fig. 1
Abb. 1

ADJUSTMENTS · EINSTELLVERFAHREN · RÉGLAGES

● BBD Output Clock Canceller Adjustment

Set the range of the A.C. voltmeter to 100 mV (Max), Connect to point A, and set Time/cm on the oscilloscope to 0.5 msec. Observe the waveform on the oscilloscope, and adjust R585 such that the BBD output clock elements are eliminated (adjust to give the central waveform in Fig. 2)

● BBD-Einstellung des Ausgangsuhrunterbrechers

Das Wechselstrom-Voltmeter auf 100 mV (max.) stellen, an Punkt A anschließen und Zeit/cm auf dem Oszilloskop auf 0,5 mSek. stellen. Die Wellenform auf dem Oszilloskop beobachten und den R585 so justieren, daß die BBD-Ausgangsuhrerelemente eliminiert werden (so einstellen, daß die in Abb. 2 gezeigte Mittenwellenform entsteht).

● Réglage d'annulation horaire de sortie BBD

Régler la gamme du voltmètre de courant secteur à 100 mV (maximum), raccorder en A et régler le temps/cm sur l'oscilloscope à 0,5 msec. Tout en observant la forme de l'onde sur l'oscilloscope, ajuster R585 de sorte que les caractéristiques horaires de la sortie BBD soient annulées (ajuster de manière à obtenir une onde centrale du type de celle de la Fig. 2).

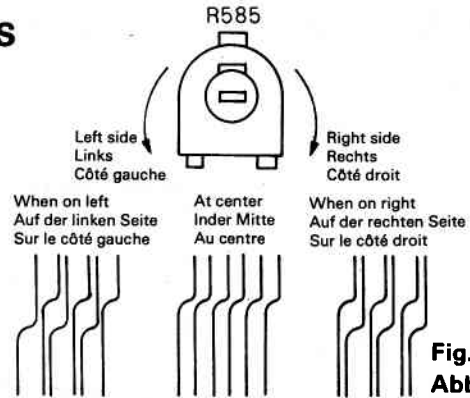

Fig. 2
Abb. 2

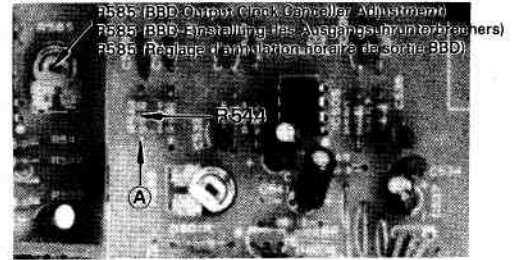
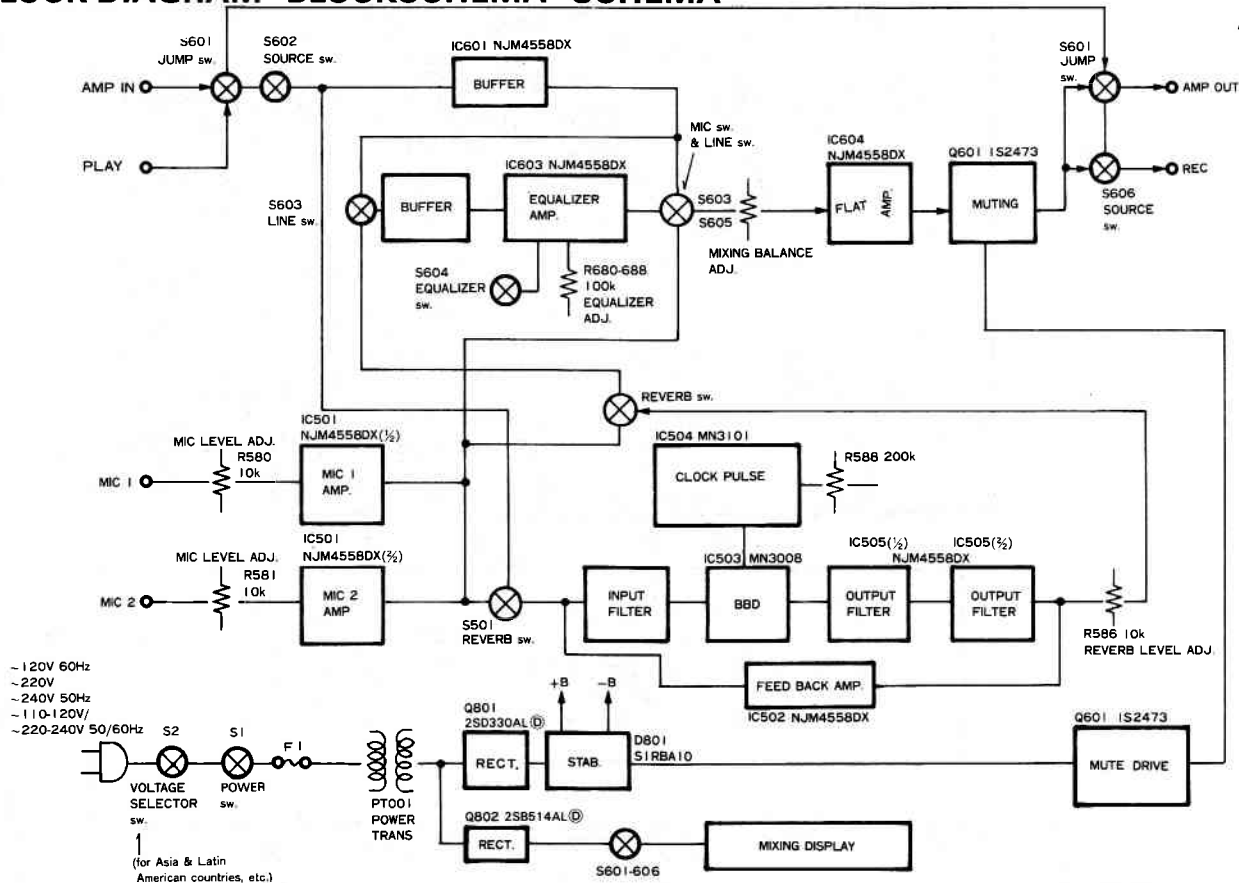

Fig. 3
Abb. 3

BLOCK DIAGRAM · BLOCKSCHEMA · SCHEMA



Check that exposed parts are acceptably insulated from the supply circuit before returning the instrument repaired to the customer.

● Checking method

- Power switch is set to ON -
- Next, measure the resistance value between the both poles of attachment cup (Power supply plug) and the input terminal (outside) of rear plate and check that the resistance value is 500 kohms or more.

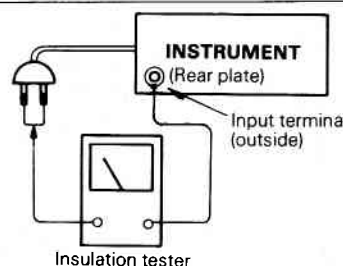

PRINTED WIRING BOARD · PRINTPLATTEN · PLAN DE BASE

[■ : Earth, ■ : Other]

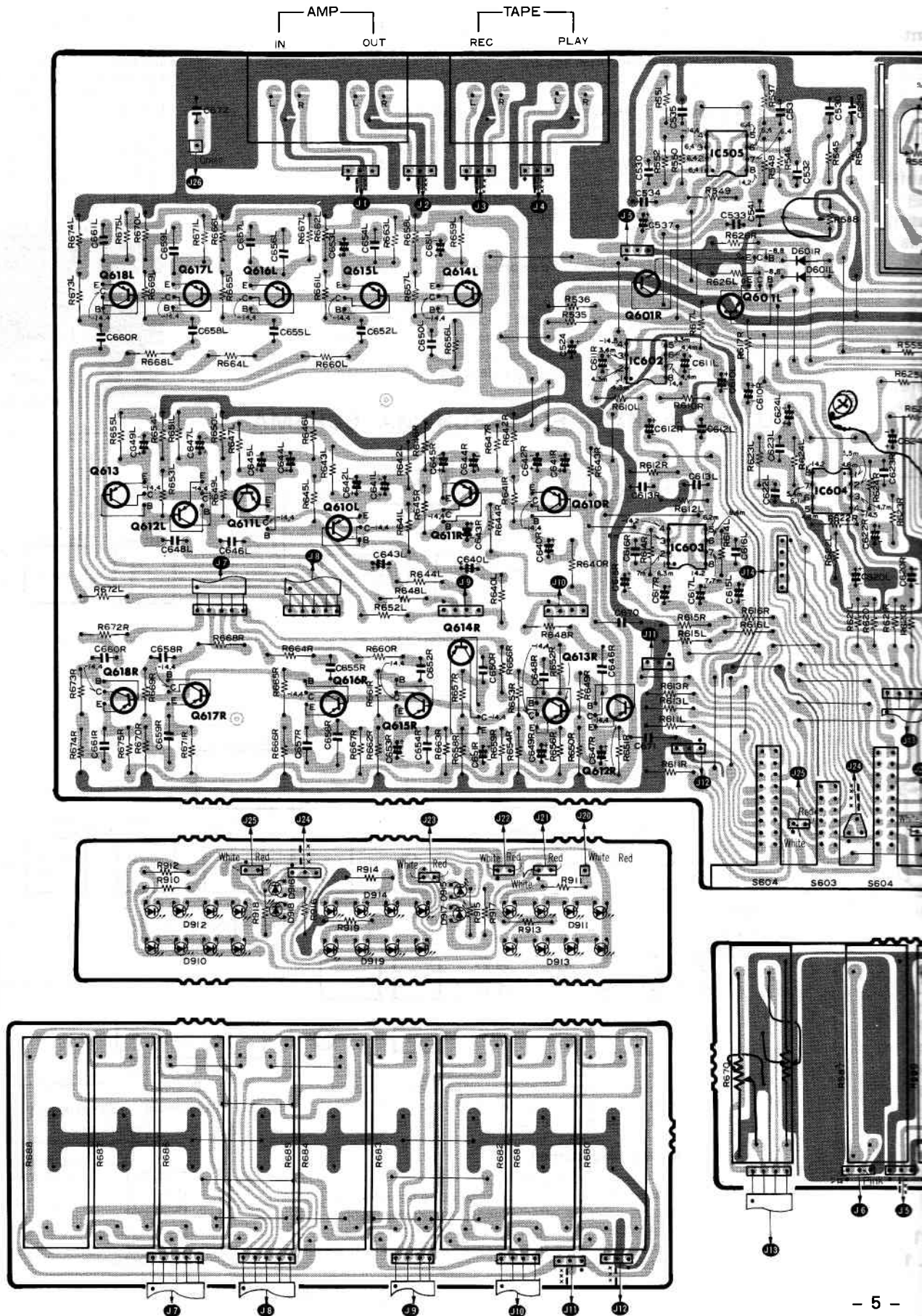

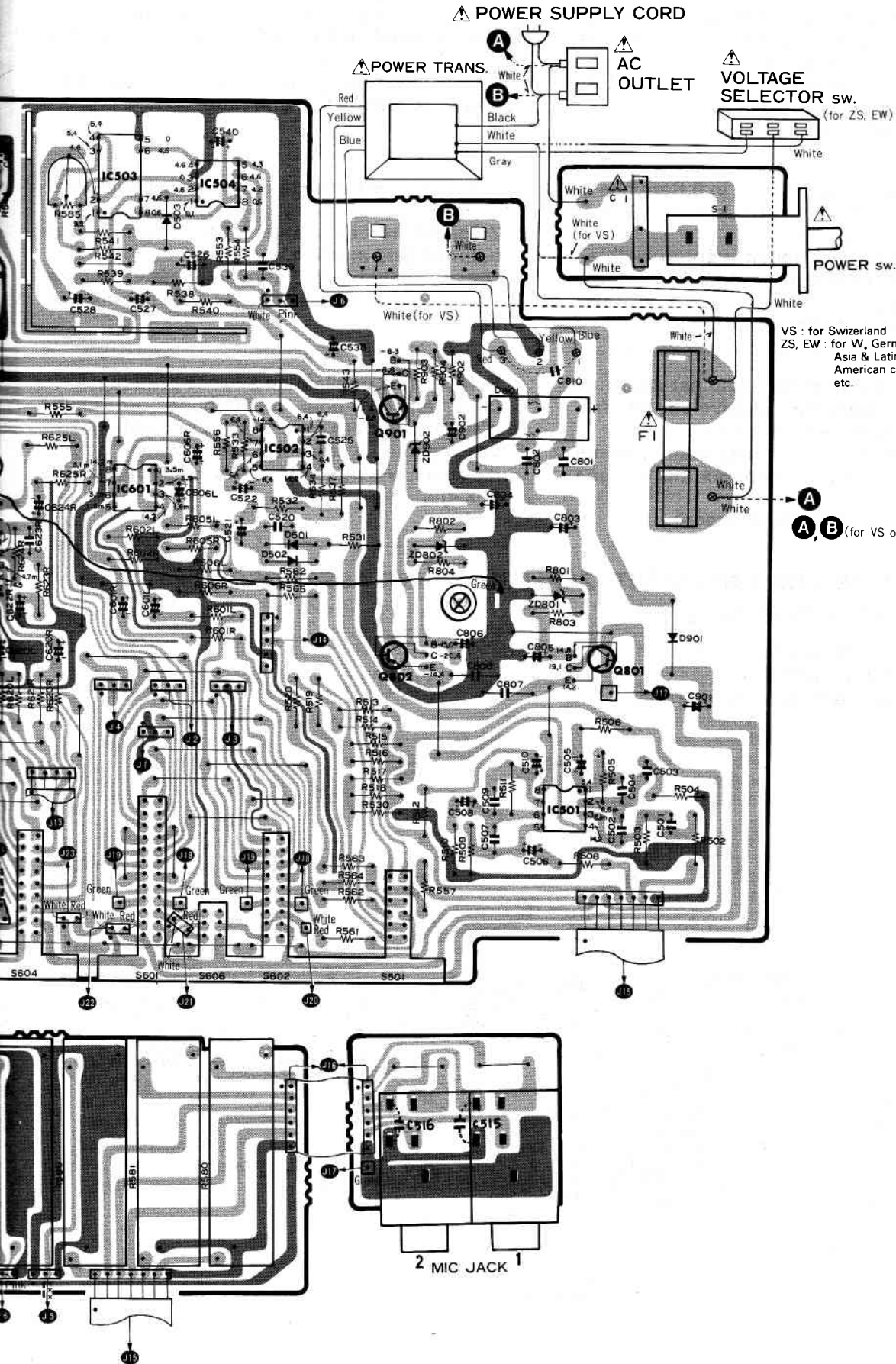

VS : for Switzerland
 ZS, EW : for W. Germany,
 Asia & Latin
 American countries,
 etc.

A
 A, B (for VS only)

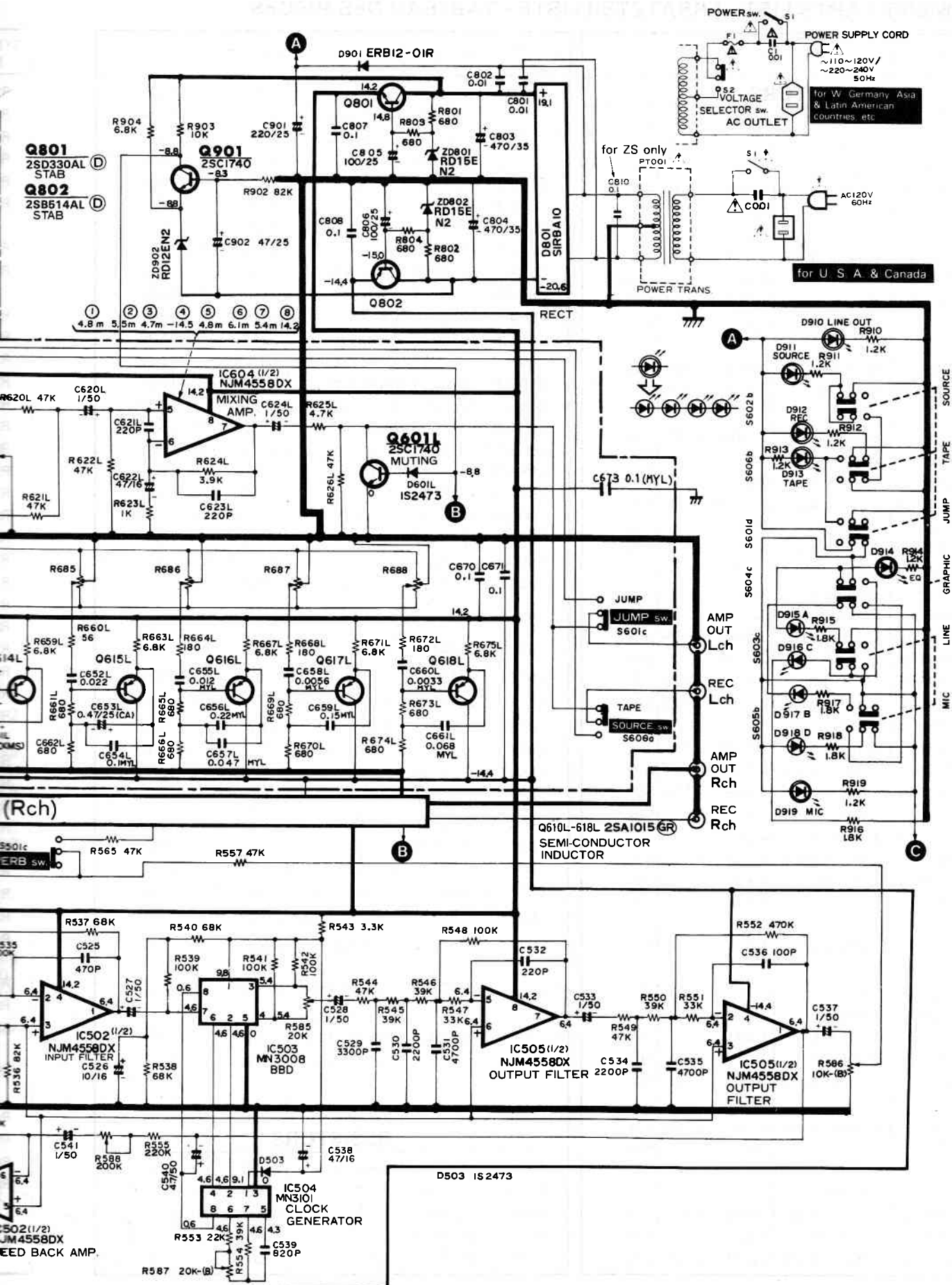

REPLACEMENT PARTS LIST · ERSATZTEILLISTE · TABLEAU DES PIECES

SYMBOL NO.	PART NO.	DESCRIPTION		
CAPACITORS				
C501	0252811	Electrolytic	1 μ F	50V
C502	0248732	Ceramic, discal	220pF \pm 10%	50V
C503	0252525	Electrolytic	47 μ F	16V
C504	0249521	Ceramic, discal	470pF \pm 10%	50V
C505	0252811	Electrolytic	1 μ F	50V
C506	0252811	Electrolytic	1 μ F	50V
C507	0248732	Ceramic, discal	220pF \pm 10%	50V
C508	0252522	Electrolytic	47 μ F	16V
C509	0249521	Ceramic, discal	470pF \pm 10%	50V
C510	0252811	Electrolytic	1 μ F	50V
C515	0276013	Mylar, film	0.22 μ F \pm 10%	50V
C516	0276013	Mylar, film	0.22 μ F \pm 10%	50V
C520	0244101	Ceramic, discal	1000pF \pm 10%	50V
C521	0252811	Electrolytic	1 μ F	50V
C522	0252811	Electrolytic	1 μ F	50V
C523	0244109	Ceramic, discal	4700pF \pm 10%	50V
C524	0252521	Electrolytic	10 μ F	16V
C525	0249521	Ceramic, discal	470pF \pm 10%	50V
C526	0252521	Electrolytic	10 μ F	16V
C527	0252811	Electrolytic	1 μ F	50V
C528	0252811	Electrolytic	1 μ F	50V
C529	0244107	Ceramic, discal	3300pF \pm 10%	50V
C530	0244105)	2200pF \pm 10%	50V
C531	0244109		4700pF \pm 10%	50V
C532	0248732	Ceramic, discal	220pF \pm 10%	50V
C533	0252811	Electrolytic	1 μ F	50V
C534	0244105	Ceramic, discal	2200pF \pm 10%	50V
C535	0244109	Ceramic, discal	4700pF \pm 10%	50V
C536	0248724	Electrolytic	100pF \pm 10%	50V
C537	0252811	Electrolytic	1 μ F	50V
C538	0252525	Electrolytic	47 μ F	16V
C539	0249726	Ceramic, discal	820pF \pm 10%	50V
C540	0252815	Electrolytic	4.7 μ F	50V
C541	0252811	Electrolytic	1 μ F	50V
C601LR	0252811	Electrolytic	1 μ F	50V
C606LR	0252811	Electrolytic	1 μ F	50V
C610LR	0252811	Electrolytic	1 μ F	50V
C611LR	0252521	Electrolytic	10 μ F	16V
C612LR	0252521	Electrolytic	10 μ F	16V
C613LR	0248716	Ceramic, discal	47pF \pm 10%	50V
C616LR	0248716	Ceramic, discal	47pF \pm 10%	50V
C617LR	0252811	Electrolytic	1 μ F	50V
C620LR	0252811	Electrolytic	1 μ F	50V
C621LR	0248732	Ceramic, discal	220pF \pm 10%	50V
C622LR	0252525	Electrolytic	47 μ F	16V
C623LR	0248732	Ceramic, discal	220pF \pm 10%	50V

SYMBOL NO.	PART NO.	DESCRIPTION			
C624LR	0252811	Electrolytic	1 μ F	50V	
C640LR	0252877	Electrolytic	1 μ F	50V	
C641LR	0252571	Electrolytic	10 μ F	16V	
C642LR	0252880)	4.7 μ F	50V	
C643LR	0252875		0.47 μ F	50V	
C644LR	0252880)	4.7 μ F	50V	
C645LR	0252879		Electrolytic	3.3 μ F	50V
C646LR	1276232	Mylar, film	0.18 μ F \pm 5%	50V	
C647LR	0252880	Electrolytic	4.7 μ F	50V	
C648LR	1276211	Mylar, film	0.1 μ F \pm 5%	50V	
C649LR	0252878	Electrolytic	2.2 μ F	50V	
C650LR	1275215	Mylar, film	0.047 μ F \pm 5%	50V	
C651LR	0252877	Electrolytic	1 μ F	50V	
C652LR	1275213	Mylar, film	0.022 μ F \pm 5%	50V	
C653LR	0252875	Electrolytic	0.47 μ F	50V	
C654LR	1276211	Mylar, film	0.1 μ F \pm 5%	50V	
C655LR	1275231)	0.012 μ F \pm 5%	50V	
C656LR	1276213		0.22 μ F \pm 5%	50V	
C657LR	1275215)	0.047 μ F \pm 5%	50V	
C658LR	1274235		5600pF \pm 5%	50V	
C659LR	1276212)	0.15 μ F \pm 5%	50V	
C660LR	1274214		3300pF \pm 5%	50V	
C661LR	1275216	Mylar, film	0.068 μ F \pm 5%	50V	
C670	0244181	Ceramic, discal	0.1 μ F $\begin{smallmatrix} +80 \\ -20 \end{smallmatrix}$	50V	
C671	0244181)	0.1 μ F $\begin{smallmatrix} +80 \\ -20 \end{smallmatrix}$	50V	
C672	0244171		Ceramic, discal	0.01 μ F $\begin{smallmatrix} +80 \\ -20 \end{smallmatrix}$	50V
C673	0276011	Mylar, film	0.1 μ F \pm 10%	50V	
C801	0244171	Ceramic, discal	0.01 μ F $\begin{smallmatrix} +80 \\ -20 \end{smallmatrix}$	50V	
C802	0244171	Ceramic, discal	0.01 μ F $\begin{smallmatrix} +80 \\ -20 \end{smallmatrix}$	50V	
C803	0252735)	470 μ F	35V	
C804	0252735		470 μ F	35V	
C805	0252631)	100 μ F	25V	
C806	0252631		Electrolytic	100 μ F	25V
C807	0244181	Ceramic, discal	0.1 μ F $\begin{smallmatrix} +80 \\ -20 \end{smallmatrix}$	16V	
C808	0244181	Ceramic, discal	0.1 μ F $\begin{smallmatrix} +80 \\ -20 \end{smallmatrix}$	16V	
C901	0252632	Electrolytic	220 μ F	25V	
Δ C1	0243899	Ceramic, discal	0.01 μ F $\begin{smallmatrix} +100 \\ -0 \end{smallmatrix}$	125V	
		(for U.S.A. & Canada)			
Δ C1	0243901	Ceramic, discal	0.01 μ F $\begin{smallmatrix} +100 \\ -0 \end{smallmatrix}$	400V	
		(except U.S.A. & Canada)			
RESISTORS					
R502	0129579)	Carbon film	560 Ω \pm 5%)
R503	0129647		47k Ω \pm 5%		
R504	0129551)	68 Ω \pm 5%)	
R505	0129635		15k Ω \pm 5%		
R506	0129601	Carbon film	1k Ω \pm 5%	SRD 1/4P	

SYMBOL NO.	PART NO.	DESCRIPTION		
R508	0129579	Carbon film	560Ω ±5%	SRD 1/4P
R509	0129647	⌋	47kΩ ±5%	⌋
R510	0129551	Carbon film	68Ω ±5%	SRD 1/4P
R511	0129635	Carbon film	15kΩ ±5%	SRD 1/4P
R512	0129603	⌋	1kΩ ±5%	⌋
R513	0129643	⌋	33kΩ ±5%	⌋
R516	0129643	Carbon film	33kΩ ±5%	SRD 1/4P
R517	0129639	⌋	22kΩ ±5%	⌋
R520	0129639	⌋	22kΩ ±5%	⌋
R530	0129619	Carbon film	5.6kΩ ±5%	SRD 1/4P
R531	0129561	⌋	100Ω ±5%	⌋
R532	0129647	⌋	47kΩ ±5%	⌋
R533	0129669	⌋	220kΩ ±5%	⌋
R534	0129645	⌋	39kΩ ±5%	⌋
R535	0129661	⌋	100kΩ ±5%	⌋
R536	0129653	⌋	82kΩ ±5%	⌋
R537	0129651	⌋	68kΩ ±5%	⌋
R538	0129651	⌋	68kΩ ±5%	⌋
R539	0129661	⌋	100kΩ ±5%	⌋
R540	0129651	⌋	68kΩ ±5%	⌋
R541	0129661	⌋	100Ω ±5%	⌋
R542	0129661	⌋	100Ω ±5%	⌋
R543	0129613	⌋	3.3kΩ ±5%	⌋
R544	0129647	⌋	47kΩ ±5%	⌋
R545	0129645	⌋	39kΩ ±5%	⌋
R546	0129645	⌋	39kΩ ±5%	⌋
R547	0129643	⌋	33kΩ ±5%	⌋
R548	0129661	⌋	100kΩ ±5%	⌋
R549	0129647	⌋	47kΩ ±5%	⌋
R550	0129645	⌋	39kΩ ±5%	⌋
R551	0129643	⌋	33kΩ ±5%	⌋
R552	0129677	⌋	470kΩ ±5%	⌋
R553	0129639	⌋	22kΩ ±5%	⌋
R554	0129645	⌋	39kΩ ±5%	⌋
R555	0129669	⌋	220kΩ ±5%	⌋
R556	0129665	⌋	150kΩ ±5%	⌋
R557	0129647	Carbon film	47kΩ ±5%	SRD 1/4P
R560	0129661	Carbon film	100kΩ ±5%	SRD 1/4P
R561	0129661	⌋	100kΩ ±5%	⌋
R562	0129647	Carbon film	47kΩ ±5%	⌋
R565	0129647	Carbon film	47kΩ ±5%	SRD 1/4P
R601LR	0129637	Carbon film	18kΩ ±5%	SRD 1/4P
R602LR	0129639	Carbon film	22kΩ ±5%	SRD 1/4P
R605LR	0129637	Carbon film	18kΩ ±5%	SRD 1/4P
R606LR	0129669	Carbon film	220kΩ ±5%	SRD 1/4P
R610LR	0129643	Carbon film	33kΩ ±5%	SRD 1/4P
R611LR	0129619	/	5.6kΩ ±5%	/

SYMBOL NO.	PART NO.	DESCRIPTION		
R612LR	0129667	⌋	180kΩ ±5%	⌋
R613LR	0129619	⌋	5.6kΩ ±5%	⌋
R614LR	0129641	⌋	27kΩ ±5%	⌋
R615LR	0129661	⌋	100kΩ ±5%	⌋
R616LR	0129635	⌋	15kΩ ±5%	⌋
R617LR	0129669	Carbon film	220kΩ ±5%	SRD 1/4P
R620LR	0129647	Carbon film	47kΩ ±5%	SRD 1/4P
R621LR	0129647	Carbon film	47kΩ ±5%	SRD 1/4P
R622LR	0129647	⌋	47kΩ ±5%	⌋
R623LR	0129601	⌋	1kΩ ±5%	⌋
R624LR	0129615	⌋	3.9kΩ ±5%	⌋
R625LR	0129617	⌋	4.7kΩ ±5%	⌋
R626LR	0129647	Carbon film	47kΩ ±5%	SRD 1/4P
R640LR	0129563	Carbon film	120Ω ±5%	SRD 1/4P
R641LR	0129581	⌋	680Ω ±5%	⌋
R642LR	0129581	⌋	680Ω ±5%	⌋
R643LR	0129621	⌋	6.8kΩ ±5%	⌋
R644LR	0129563	⌋	120Ω ±5%	⌋
R645LR	0129581	⌋	680Ω ±5%	⌋
R646LR	0129581	⌋	680Ω ±5%	⌋
R647LR	0129621	⌋	6.8kΩ ±5%	⌋
R648LR	0129549	⌋	56Ω ±5%	⌋
R649LR	0129581	⌋	680Ω ±5%	⌋
R650LR	0129581	⌋	680Ω ±5%	⌋
R651LR	0129621	⌋	6.8kΩ ±5%	⌋
R652LR	0129531	⌋	10Ω ±5%	⌋
R653LR	0129581	⌋	680Ω ±5%	⌋
R654LR	0129581	⌋	680Ω ±5%	⌋
R655LR	0129621	⌋	6.8kΩ ±5%	⌋
R656LR	0129547	⌋	47Ω ±5%	⌋
R657LR	0129581	⌋	680Ω ±5%	⌋
R658LR	0129581	⌋	680Ω ±5%	⌋
R659LR	0129621	⌋	6.8kΩ ±5%	⌋
R660LR	0129549	⌋	56Ω ±5%	⌋
R661LR	0129581	⌋	680Ω ±5%	⌋
R662LR	0129581	⌋	680Ω ±5%	⌋
R663LR	0129621	⌋	6.8kΩ ±5%	⌋
R664LR	0129567	⌋	180Ω ±5%	⌋
R665LR	0129581	⌋	680Ω ±5%	⌋
R666LR	0129581	⌋	680Ω ±5%	⌋
R667LR	0129621	⌋	6.8kΩ ±5%	⌋
R668LR	0129567	⌋	180Ω ±5%	⌋
R669LR	0129581	⌋	680Ω ±5%	⌋
R670LR	0129581	⌋	680Ω ±5%	⌋
R671LR	0129621	⌋	6.8kΩ ±5%	⌋
R672LR	0129567	⌋	180Ω ±5%	⌋
R673LR	0129581	⌋	680Ω ±5%	⌋
R674LR	0129581	⌋	680Ω ±5%	⌋
R675LR	0129621	Carbon film	6.8kΩ ±5%	SRD 1/4P

SYMBOL NO.	PART NO.	DESCRIPTION		
R801 S	0129581 S	Carbon film S	680Ω ± 5%	SRD 1/4P S
R804	0129581	Carbon film	680Ω ± 5%	SRD 1/4P
R902	0129653	Carbon film	82kΩ ± 5%	SRD 1/4P
R903	0129631	Carbon film	10kΩ ± 5%	SRD 1/4P
R904	0129621	Carbon film	6.8kΩ ± 5%	SRD 1/4P
R910 S	0129603 S	Carbon film S	1.2kΩ ± 5%	SRD 1/4P S
R914	0129603	Carbon film	1.2kΩ ± 5%	SRD 1/4P
R915	0129607	Carbon film	1.8kΩ ± 5%	SRD 1/4P
R918 S	0129607 S	Carbon film S	1.8kΩ ± 5%	SRD 1/4P S
R919	0129603	Carbon film	1.2kΩ ± 5%	SRD 1/4P

ICs & TRANSISTORS

IC501	2368041	NJM 4558 DX
IC502	2368041	NJM 4558 DX
IC503	2369941	MN 3008
IC504	2368781	MN 3101
IC505	2368041	NJM 4558 DX
IC601 S	2368041 S	NJM 4558 DX S
IC604	2368041	NJM 4558 DX
Q601LR	2328651	2SA1740LN ®
Q610LR S	2329183 S	2SA1015 ® S
Q615LR	2329183	2SA1015 ®
Q616LR	2329183	2SA1015 ®
Q618LR S	2329183 S	2SA1015 ® S
Q801	2317737	2SD330AL ©
Q802	2328962	2SB514AL ©
Q901	2329385	2SC1740 ©

DIODES

D503	2337601	1S2473
D601LR	2337061	1S2473
D801	2337372	S1RBA10
D901	2337762	ERB12-01R
D910	2339381	LED LT 9110N (Green)
D911	2339381	LED LT 9110 (Green)
D912	2339382	LED LT 9110H (Orange)

SYMBOL NO.	PART NO.	DESCRIPTION
D913	2339381	LED LT 9110N (Green)
D914	2339381	LED LT 9110N (Green)
D915 S	2339731 S	LED SLP 153B (Red) S
D918	2339731	LED SLP 153B (Red)
D919	2339381	LED LT 9110N (Green)
ZD801	2338631	RD15EN2
ZD802	2338631	RD15EN2
ZD902	2338625	RD12EN2

VARIABLE RESISTORS

R580	0166571	10kΩ-(B) (MIC 1 level)
R581	0166571	10kΩ-(B) (MIC 2 level)
R585	0150959	20kΩ-(B) (for BBD output adj.)
R586	0166571	10kΩ-(B) (REVERB level)
R587	0166572	20kΩ-(B) (DELAY)
R588	0150962	200kΩ-(B)
R670	0166573	200kΩ-(W)
R680 S	0166574 S	100kΩ-(W) S
R688	0166574	100kΩ-(W) } (for freq. level adj.)

MISCELLANEOUS

	2639823	Push switch (REVERB, FUNCTION)
	2639824	Push switch (EQUALIZER)
	2677613	4P US pin jack
J001	2678381	Mic jack
△ F001	2727015	Fuse-500mA, 250V (for U.S.A. & Canada)
△ F001	2727197	Fuse-T500mA (except U.S.A. & Canada)
	2727161	Lamp holder (for U.S.A. & Canada)
	2727602	Fuse clip (except U.S.A. & Canada)
△ S1	2639512	Power switch (for U.S.A. & Canada)
△ S1	2639513	Power switch (except U.S.A. & Canada)

for FINAL ASSEMBLY

4022222	Escutcheon ass'y
3954992	Knob ass'y (for freq. level)
4443555	Cover (except U.S.A. & Canada)
4443557	Cover (for U.S.A. & Canada)
4567462	4øx8DT bind screw (for cover)
4567411	3øx6DT bind screw (for escutcheon)
4568851	3øx6DT flat head screw (for escutcheon)

SYMBOL NO.	PART NO.	DESCRIPTION	SYMBOL NO.	PART NO.	DESCRIPTION
for DIAL MECHANISM ASSEMBLY					
	4447161	Sub panel			
	3952741	Push button (POWER)			
	3291251	Push button (REVERB, FUNCTION)			
	3944192	Leg			
	3924472	PL rivet			
	4567411	3øx6DT bind screw			
	4567454	3øx12DT bind screw			
	4784106	3øx10 bind tapping screw			
	4580931	2øx3 pan head screw			
	4567412	3øx8DT bind screw			
for REAR PLATE ASSEMBLY					
	4446862	Rear plate (for U.S.A.)			
	4446863	Rear plate (for Canada)			
	4446864	Rear plate (for France & W. Germany)			
	4446865	Rear plate (for Australia)			
	4446866	Rear plate (for Asia & Latin American countries, etc.)			
△	0043793	Bushing (for U.S.A. & Canada)			
△	3913006	Bushing (except U.S.A. & Canada)			
△	2718113	Power supply cord (for U.S.A. & Canada)			
△	2749622	Power supply cord (for Australia)			
△	2748752	Power supply cord (except U.S.A., Canada & Australia)			
△	2657721	AC outlet (for U.S.A.)			
△	2658372	AC outlet (for Canada)			
△	2657741	AC outlet (except U.S.A., Canada & Australia)			
△ S2	2627221	Voltage selector switch (for Asia & Latin American countries, etc.)			
△ T001	2247782	Power transformer (for U.S.A. & Canada)			
△ T001	2247783	Power transformer (for France, Australia & W. Germany)			
△ T001	2247785	Power transformer (for Asia & Latin American countries, etc.)			
	4784106	3øx10 bind tapping screw (for Asia & Latin American countries, etc.)			
	4567431	3øx6DT bind screw			
for ACCESSORIES					
	2748851	Patch cord			
△	2658361	E socket adaptor (for Asia & Latin American countries, etc.)			

FRONT AND REAR PANELS · VORDERE UND HINTERE BEDIENUNGSTAFEL ·
PANNEAUX AVANT ET ARRIERE

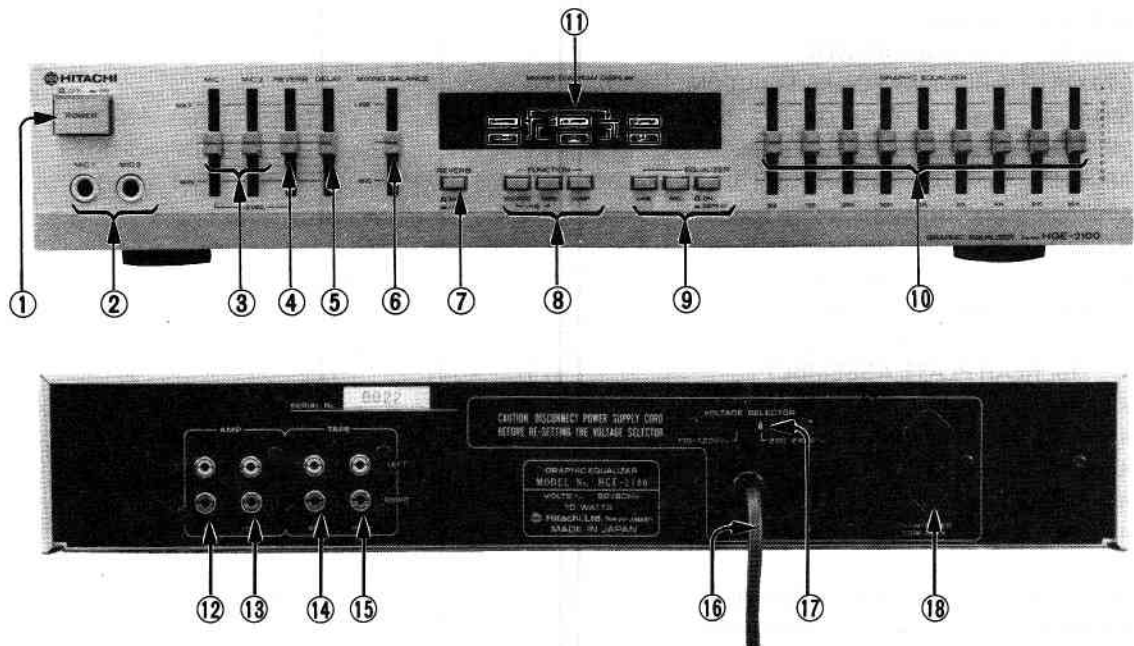

- ① POWER switch
- ② MIC 1, MIC 2 jacks
- ③ MIC 1 LEVEL, MIC 2 LEVEL controls
- ④ REVERB LEVEL control
- ⑤ DELAY control
- ⑥ MIXING BALANCE control
- ⑦ REVERB selector switch
- ⑧ FUNCTION selector switches
- ⑨ EQUALIZER selector switches
- ⑩ Equalizer control knobs
- ⑪ MIXING DIAGRAM DISPLAY
- ⑫ AMP IN jacks
- ⑬ AMP OUT jacks
- ⑭ TAPE REC jacks
- ⑮ TAPE PLAY jacks
- ⑯ Power supply cord
- ⑰ VOLTAGE SELECTOR (for W. Germany, Asia & Latin American countries)
- ⑱ AC outlet

- ① Netzschalter (POWER)
- ② MIC 1, MIC 2 buchse
- ③ Mikrofonpegelregler (MIC 1 LEVEL, MIC 2 LEVEL)
- ④ Hallpegelregler (REVERB LEVEL)
- ⑤ Verzögerungsregler (DELAY)
- ⑥ Mischbalanceregler (MIXING BALANCE)
- ⑦ Hallwahlschalter (REVERB)
- ⑧ Funktionswahlschalter (FUNCTION)
- ⑨ Entzerrungswahlschalter
- ⑩ Entzerrerregler
- ⑪ Mischdiagramm-Anzeige (MIXING DIAGRAM DISPLAY)
- ⑫ AMP-Eingangsbuchse (AMP IN)
- ⑬ AMP-Ausgangsbuchse (AMP OUT)
- ⑭ Bandaufnahmebuchsen (TAPE REC)
- ⑮ Bandwiedergabebuchsen (TAPE PLAY)
- ⑯ Netzkabel
- ⑰ Spannungswähler (VOLTAGE SELECTOR) (für die Bundesrepublik Deutschland, Asien und Lateinamerika)
- ⑱ Kaltgerätestecker (für die Bundesrepublik Deutschland, Asien und Lateinamerika)

- ① Interrupteur d'alimentation (POWER)
- ② Prises microphone 1 et microphone 2 (MIC 1, MIC 2)
- ③ Réglages de niveau de microphone 1 et microphone 2 (MIC 1 LEVEL, MIC 2 LEVEL)
- ④ Régalage de niveau de réflexion (REVERB LEVEL)
- ⑤ Réglage de retardement (DELAY)
- ⑥ Réglage d'équilibre de mixage (MIXING BALANCE)
- ⑦ Sélecteur de réflexion (REVERB)
- ⑧ Sélecteurs de fonction (FUNCTION)
- ⑨ Sélecteurs d'égalisation (EQUALIZER)
- ⑩ Commandes d'égalisation
- ⑪ Affichage de schéma de mixage (MIXING DIAGRAM DISPLAY)
- ⑫ Prises d'entrée d'amplificateur (AMP IN)
- ⑬ Prises de sortie d'amplificateur (AMP OUT)
- ⑭ Prise d'enregistrement de bande (TAPE REC)
- ⑮ Prises de lecture bande (TAPE PLAY)
- ⑯ Cordon d'alimentation
- ⑰ Sélecteur de tension (VOLTAGE SELECTOR) (pour l'Allemagne de l'Ouest, l'Asie et l'Amérique Latine)
- ⑱ Prise de courant secteur (pour l'Allemagne de l'Ouest, l'Asie et l'Amérique Latine)



HITACHI SALES CORPORATION OF AMERICA
Eastern Regional Office

1200 Wall Street West, Lyndhurst, New Jersey
07071, U.S.A.

Tel. 201-935-8980

Mid-Western Regional Office

1400 Morse Ave., Elk Grove Village, Ill. 60007, U.S.A.
Tel. 312-593-1550

Southern Regional Office

510 Plaza Drive College Park, Georgia 30349, U.S.A.
Tel. 404-763-0360

Western Regional Office

401 West Artesia Boulevard, Compton, California
90220, U.S.A.

Tel. 213-537-8383

HITACHI SALES CORPORATION OF HAWAII, INC.

3219 Koapaka Street Honolulu, Hawaii 96819, U.S.A.
Tel. 808-836-3621

HITACHI (HSC) CANADA INC.

3300 Trans Canada Highway, Pointe Claire, Quebec
H9R 1B1, Canada

Tel. 514-697-9150

HITACHI SALES EUROPA GmbH

2050 Hamburg 54, Rungedamm 2, West Germany
Tel. 73411-0

HITACHI SALES (U.K.) Ltd.

Hitachi House, Station Road, Hayes, Middlesex UB3
4DR, England

Tel. 01-848-8787 (Service Centre: 01-848-3551)

HITACHI SALES SCANDINAVIA AB

Rissneleden 8, Box 7138, 172-07 Sundbyberg,
Sweden

Tel. 08-98 52 80

HITACHI SALES NORWAY A/S

Oerebekk 1620 Gressvik P.O. Box 46 N-1601
Fredrikstad, Norway

Tel. 032-28255

SUOMEN HITACHI OY

Takojanckatsu 5, 15800 Lahti 80, Finland
Tel. Lahti 44 241

HITACHI SALES A/S

Kuldysen 13, DK-2630 Taastrup, Denmark
Tel. 02-999200

HITACHI SALES A.G.

Bahnhofstrasse, 19, 5600 Lenzburg,
Switzerland

Tel. 064-513621

HITACHI FRANCE S.A.

97/115 Rue Charles-Michels 93200
SAINT-DENIS, France

Tel. 201-25-00

HITACHI SALES WARENHANDELS GMBH

A-1180/Wien, Kreuzgasse 27, Austria
Tel. (0222) 439367/8

HITACHI SALES BELGIUM S.A./N.V.

56, Chaussee de Namur, B-1400
Nivelles, Belgium

Tel. (067) 22 71 81

HITACHI SALES AUSTRALIA Pty Ltd.

153 Keys Road, Moorabbin, Victoria 3189 Australia
Tel. 555-8722

HITACHI Ltd. TOKYO JAPAN

Head Office: 5-1, 1-chome, Marunouchi, Chiyoda-
ku, Tokyo 100, Japan
Tel. Tokyo (212) 1111

Cable Address: "HITACHY" TOKYO