

HITACHI

SERVICE MANUAL

TY

No. 575 EF

HRD-MD38 [BS, KS, ES, VS, ZS, AU, W (UN), EW]
 HRD-MD53 [US, CS]
 HT-MD28 [BS, KS, ES, VS, ZS, AU, US, CS, W (UN), EW]

HRD-MD38/
HRD-MD53

HRD-MD38
for W (UN)

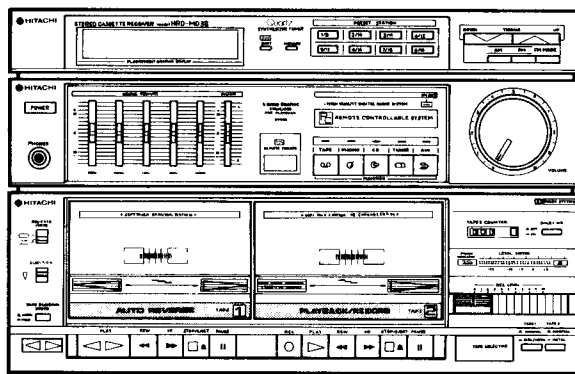
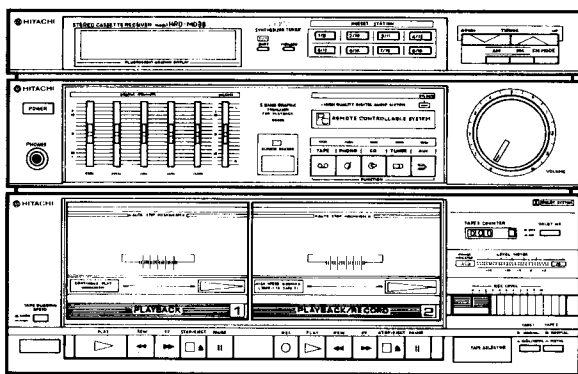

HT-MD28

• RB-38

• HS-MD38

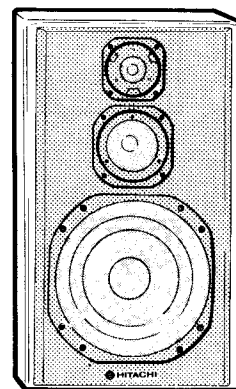
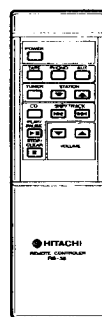
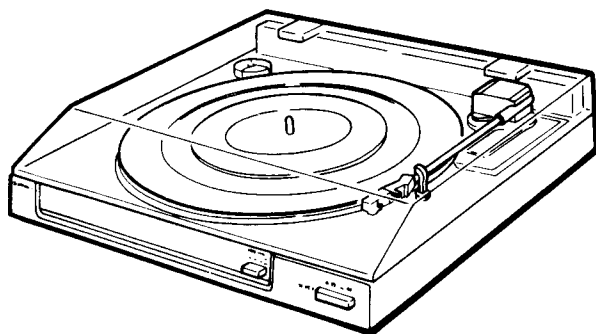

CONTENTS

KEY TO ILLUSTRATIONS	2
SPECIFICATIONS	5
DISASSEMBLY	8
ADJUSTMENT	10
INSPECTION OF MECHANISM	15
LUBRICATION	16
CIRCUIT DIAGRAM	17
PRINTED WIRING BOARD	20
BLOCK DIAGRAM	23
EXPLODED VIEW	24
REPLACEMENT PARTS LIST	29

TABLE DES MATIERES

LEGENDES DES ILLUSTRATIONS	2
FICHE TECHNIQUE	5
DEMONTAGE	8
REGLAGE	10
INSPECTION DU MECANISME	15
LUBRIFICATION	16
DIAGRAMME DES CIRCUITS	17
PLAN DE BASE	20
DIAGRAMME SYNOPTIQUE	23
VUE ECLATEE	24
LISTE DES PIECES DE RECHANGE	29

SPECIFICATIONS AND PARTS ARE SUBJECT TO CHANGE FOR IMPROVEMENT.

STEREO TUNER-AMPLIFIER DOUBLE CASSETTE RECORDER

September 1987

TOYOKAWA WORKS

HRD-MD38/
HRD-MD53

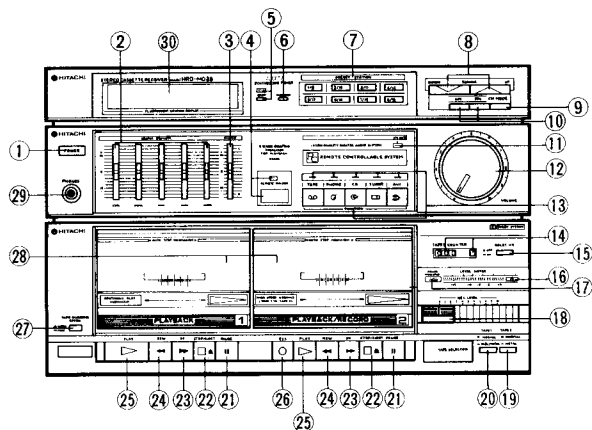

HRD-MD38
for W (UN)

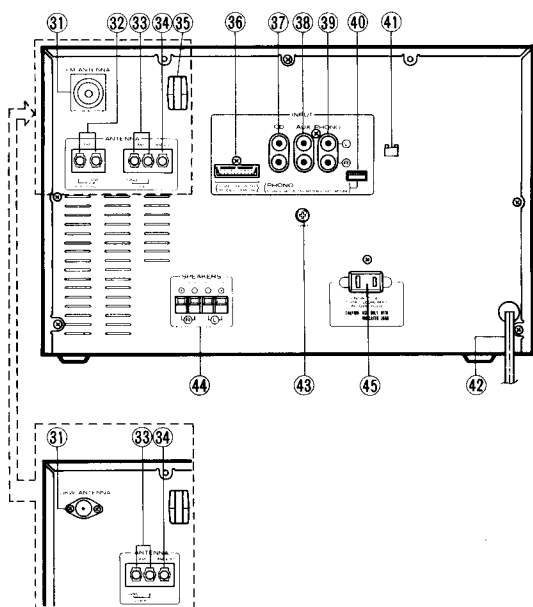
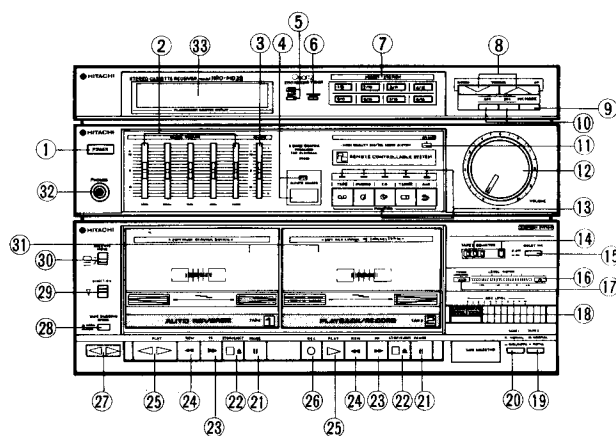

For W. Germany

Pour l'Allemagne de l'ouest

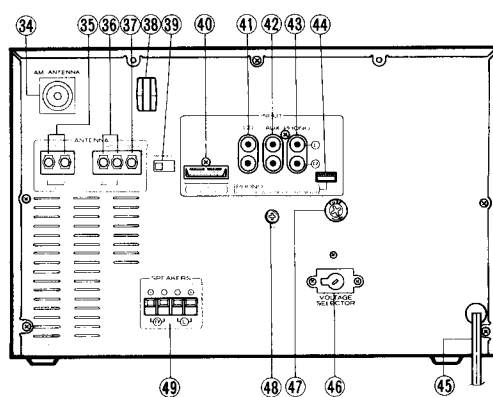

KEY TO ILLUSTRATIONS • LEGENDES DES ILLUSTRATIONS

HRD-MD38/
HRD-MD53

- | | | |
|--|------------------------------------|--|
| ① Operate button (POWER) | ⑩ Level indicator | ⑳ FM antenna (aerial) terminals (75 ohms) (except W Germany) |
| ② Graphic equalizer controls | ⑪ Power indicator | ㉑ AM loop antenna terminals |
| ③ Balance control | ⑫ Recording level control | ㉒ AM external antenna terminal |
| ④ Remote sensor window / indicator | ⑬ Tape select button (TAPE-2) | ㉓ AM loop antenna holder |
| ⑤ Shift button / indicator | ⑭ Tape select button (TAPE-1) | ㉔ CD connecting socket (For DA-38) |
| ⑥ Memory write button | ⑮ Pause button () | ㉕ CD input jacks |
| ⑦ Station buttons | ⑯ Stop / Eject button (□▲) | ㉖ AUX input jacks |
| ⑧ Tuning buttons | ⑰ Fast forward button (▶▶) | ㉗ PHONO input jacks |
| ⑨ FM mode select button | ⑱ Rewind button (◀◀) | ㉘ PHONO connecting socket (For HT-MD28) |
| ⑩ Band select button | ⑲ Playback button (▶) | ㉙ RIF selector (For Europe except W Germany) |
| ⑪ FM mode "AUTO" indicator | ⑳ Recording button (○) | ㉚ Power supply cord |
| ⑫ Volume control | ㉑ Tape dubbing speed select switch | ㉛ Ground terminal |
| ⑬ Function select buttons / indicators | ㉒ Cassette holders | ㉜ Speaker terminals |
| ⑭ Tape counter / Reset button (TAPE-2) | ㉓ Headphones jack | ㉝ AC outlet (for HRD-MD53) |
| ⑮ Dolby NR switch | ㉔ Frequency display | |
| | ㉕ FM antenna jack (75 ohms) | |

- ① Touche de fonctionnement (POWER)
- ② Commandes d'égaliseur graphique
- ③ Commande d'équilibre
- ④ Fenêtre / indicateur de détecteur de télécommande
- ⑤ Touche / indicateur de déplacement
- ⑥ Touche de mise en mémoire
- ⑦ Touches de station
- ⑧ Touches d'accord
- ⑨ Touche de sélection de mode FM
- ⑩ Touche de sélection de gamme
- ⑪ Indicateur de mode FM "AUTO"
- ⑫ Bouton de réglage du volume sonore
- ⑬ Tonches de sélection / indicateurs de fonction
- ⑭ Bouton de compteur bande / remise à zéro (TAPE-2)
- ⑮ Interrupteur de réduction de bruit Dolby NR
- ⑯ Indicateur de niveau
- ⑰ Indicateur d'alimentation
- ⑱ Commande de réglage du niveau d'enregistrement
- ⑲ Touche de sélection de bande (TAPE-2)
- ⑳ Touche de sélection de bande (TAPE-1)
- ㉑ Touche de pause (||)
- ㉒ Touche d'arrêt / éjection (□▲)
- ㉓ Touche d'avance rapide (▶▶)
- ㉔ Touche de rembobinage (◀◀)
- ㉕ Touche de lecture (▷)
- ㉖ Touche d'enregistrement (○)
- ㉗ Sélecteur de vitesse de copie de bande
- ㉘ Porte-cassette
- ㉙ Prise de casque d'écoute
- ㉚ Affichage des fréquences
- ㉛ Prise d'antenne FM (75 ohms)
- ㉜ Bornes d'antenne (extérieure) FM (75 ohms) (Sauf pour l'Allemagne de l'Ouest)
- ㉝ Bornes d'antenne-cadre AM
- ㉞ Borne d'antenne extérieure AM
- ㉟ Support d'antenne-cadre AM
- ㊱ Douille de connexion de lecteur CD (pour le DA-38)
- ㊲ Prises d'entrée Disque Compact CD
- ㊳ Prises d'entrée auxiliaires (AUX)
- ㊴ Prises d'entrée PHONO
- ㊵ Douille de connexion PHONO (pour le HT-MD28)
- ㊶ Sélecteur RIF (pour l'Europe à l'exception de l'Allemagne de l'Ouest)
- ㊷ Cordon d'alimentation
- ㊸ Borne de mise à la terre
- ㊹ Bornes d'enceinte acoustique
- ㊺ Prise d'alimentation CA (pour HRD-MD53)

HRD-MD38 for W (UN)

- ① Power button
- ② Graphic equalizer controls
- ③ Balance control
- ④ Remote sensor window / indicator
- ⑤ Shift button / indicator
- ⑥ Memory write button
- ⑦ Station buttons
- ⑧ Tuning buttons
- ⑨ FM mode select button
- ⑩ Band select button
- ⑪ FM mode "AUTO" indicator
- ⑫ Volume control
- ⑬ Function select buttons / indicators
- ⑭ Tape counter / Reset button (TAPE-2)
- ⑮ Dolby NR switch
- ⑯ Level indicator
- ⑰ Power indicator
- ⑱ Recording level control
- ⑲ Tape select button (TAPE-2)
- ⑳ Tape select button (TAPE-1)
- ㉑ Pause button (||)
- ㉒ Stop / Eject button (□▲)
- ㉓ Fast forward button (▶▶)
- ㉔ Rewind button (◀◀)
- ㉕ Playback button (▷)
- ㉖ Recording button (○)
- ㉗ Direction indicators
- ㉘ Tape dubbing speed select switch
- ㉙ Direction select switch
- ㉚ Reverse mode switch
- ㉛ Cassette holders
- ㉜ Headphones jack
- ㉝ Frequency display
- ㉞ FM antenna jack (75 ohms)
- ㉟ FM antenna (aerial) terminals (75 ohms)
- ㊱ AM loop antenna terminals
- ㊲ AM external antenna terminal
- ㊳ AM loop antenna holder
- ㊴ AM spacing selector
- ㊵ CD connecting socket (For DA-38)
- ㊶ CD input jacks
- ㊷ AUX input jacks
- ㊸ PHONO input jacks
- ㊹ PHONO connecting socket (For HT-MD28)
- ㊺ Power supply cord
- ㊻ Voltage selector
- ㊼ Fuse holder
- ㊽ Ground terminal
- ㊾ Speaker terminals

- | | | |
|--|---|--|
| <ul style="list-style-type: none"> ① Touche d'alimentation ② Commandes d'égaliseur graphique ③ Commande d'équilibre ④ Fenêtre / indicateur de détecteur de télécommande ⑤ Touche / indicateur de déplacement ⑥ Touche de mise en mémoire ⑦ Touches de station ⑧ Touches d'accord ⑨ Touche de sélection de mode FM ⑩ Touche de sélection de gamme ⑪ Indicateur de mode FM "AUTO" ⑫ Bouton de réglage du volume sonore ⑬ Touches de sélection / indicateurs de fonction ⑭ Bouton de compteur bande / remise à zéro (TAPE-2) ⑮ Interrupteur de réduction de bruit Dolby NR | <ul style="list-style-type: none"> ⑯ Indicateur de niveau ⑰ Indicateur d'alimentation ⑱ Commande de réglage du niveau d'enregistrement ⑲ Touche de sélection de bande (TAPE-2) ⑳ Touche de sélection de bande (TAPE-1) ㉑ Touche de pause (■) ㉒ Touche d'arrêt / éjection (□▲) ㉓ Touche d'avance rapide (▶▶) ㉔ Touche de rembobinage (◀◀) ㉕ Touche de lecture (▷) ㉖ Touche d'enregistrement (○) ㉗ Indicateurs de sens de défilement ㉘ Sélecteur de vitesse de copie de bande ㉙ Sélecteur de sens de défilement ㉚ Sélecteur de mode d'inversion (REVERSE MODE) ㉛ Porte-cassette | <ul style="list-style-type: none"> ㉜ Prise de casque d'écoute ㉝ Affichage des fréquences ㉞ Prise d'antenne FM (75 ohms) ㉟ Bornes d'antenne (extérieure) FM (75 ohms) ㊱ Bornes d'antenne-cadre AM ㊲ Borne d'antenne extérieure AM ㊳ Support d'antenne-cadre AM ㊴ Sélecteur d'espacement AM ㊵ Douille de connexion de lecteur CD (pour le DA-38) ㊶ Prises d'entrée Disque Compact CD ㊷ Prises d'entrée auxiliaires (AUX) ㊸ Prises d'entrée PHONO ㊹ Douille de connexion PHONO (pour le HT-MD28) ㊺ Cordon d'alimentation ㊻ Sélecteur de tension ㊼ Porte-fusible ㊽ Borne de mise à la terre ㊾ Bornes d'enceinte acoustique |
|--|---|--|

• RB-38

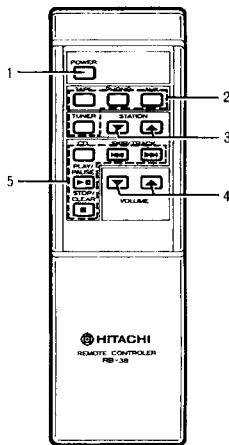

- | | |
|---|--|
| <ul style="list-style-type: none"> ① Power button ② Function select button ③ Tuning button ④ Volume control ⑤ CD operation section | <ul style="list-style-type: none"> ① Touche d'alimentation ② Touches de sélection ③ Touches d'accord ④ Bouton de réglage du volume sonore ⑤ Section de fonction |
|---|--|

HT-MD28

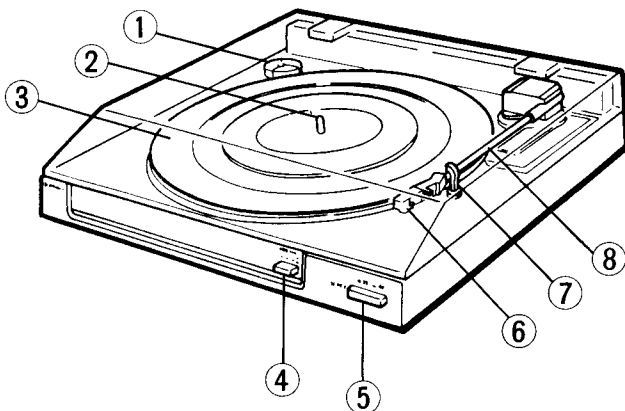

- | | |
|--|--|
| <ul style="list-style-type: none"> ① 45 rpm Adaptor ② Disc guide ③ Platter ④ Cueing button ⑤ Speed select button ⑥ Stylus ⑦ Arm rest ⑧ Tonearm | <ul style="list-style-type: none"> ① Adaptateur 45 tours ② Guide du disque ③ Plateau ④ Touche de repérage ⑤ Touche de sélection de la vitesse ⑥ Pointe de lecture ⑦ Support du bras ⑧ Bras |
|--|--|

SAFETY PRECAUTIONS

The following precautions should be observed when servicing.

1. Since many parts in the unit have special safety related characteristics, always use genuine Hitachi's replacement parts. Especially critical parts in the power circuit block should not be replaced with other makers. Critical parts are marked with Δ in the circuit diagram and printed wiring board.
2. Before returning a repaired unit to the customer, the service technician must thoroughly test the unit to ascertain that it is completely safe to operate without danger of electrical shock.

SPECIFICATIONS

HRD-MD38

GENERAL SPECIFICATIONS

Power Supply: AC 240V 50Hz
AC 220V 50Hz
AC 110-120V, 200-220V, 230-240V,
50/60Hz (Multi voltage unit)

Power Consumption: 180W
270W (for W (UN))

Dimensions: 370 (W) × 246 (H) × 299 (D) mm

Weight: 7.6kg
9.1kg (for W (UN))

AMPLIFIER SECTION

Audio Output: 30W (8 ohms, 1 kHz, T.H.D 0.7%)
50W (8 ohms, 1 kHz, T.H.D 0.7%)
(for W (UN))

Tone Control: 63Hz ± 10dB, 250Hz ± 10dB
1kHz ± 10dB, 4kHz ± 10dB
16kHz ± 10dB

Input Sensitivity and Impedance: PHONO: 3mV/50kohms
CD: 200mV/30kohms

Load Impedance: Speaker: 8 to 16ohms
Headphones: 8ohms or more

TUNER SECTION

Circuit System: FM/AM 2-band (except unit
equipped with LW band)
FM/MW/LW 3-band (for unit
equipped with LW band)
superheterodyne

Tuning Range: FM: 87.5 to 108MHz
(50kHz step)
AM (MW): 522 to 1,611kHz
(9kHz step)
530 to 1,620kHz
(10kHz step)
(for Multi voltage unit)

LW: 146 to 353kHz (1kHz step)
(for unit equipped with LW
band)

IEC Sensitivity: FM: 1.5 μ V
AM (MW, LW): 450 μ V
35dB

FM Stereo separation:
FM Signal to noise
Ratio: 60dB

Antennas input: FM: 75ohms unbalanced
AM (MW, LW): Loop antenna and
External terminals

TAPE DECK SECTION

Cassette tape deck

Tape: Cassette tape

Tape Speed: 4.75 cm/s

Recording System
and Bias Frequency: AC bias, 85 kHz

Track System: 4 track 2 channel

Erasing System: AC erase

Frequency Response: Normal: 70Hz to 14kHz
Metal: 70Hz to 14kHz

Signal-to-Noise Ratio: Dolby NR ON: 58dB
56dB (for W (UN))
Dolby NR OFF: 50dB

Crosstalk: 65dB

Erase Ratio: 70dB

Motor: DC Motor

REMOTE CONTROLLER (RB-38)

Dimensions: 50 (W) × 158 (H) × 18 (D) mm

Weight: 110 g

HRD-MD53

GENERAL SPECIFICATIONS

Power Supply: AC 120V, 60Hz

Power Consumption: 180W

Dimensions: 370 (W) × 246 (H) × 299 (D) mm

Weight: 8.3kg

AMPLIFIER SECTION

Audio Output: 50watts per channel, min. RMS,
at 8ohms from 40Hz to 20kHz,
with more than 0.9% total har-
monic distortion.

Tone Control: 63Hz ± 10dB
250Hz ± 10dB
1kHz ± 10dB
4kHz ± 10dB
16kHz ± 10dB

Input Sensitivity and Impedance: PHONO: 3mV/50kohms
CD: 200mV/30kohms

Load Impedance: Speaker: 8 to 16ohms
Headphones: 8ohms or more

TUNER SECTION

Circuit System: FM/AM 2-band
superheterodyne

Tuning Range: FM: 87.9 to 107.9MHz
(100kHz step)
AM: 530 to 1620kHz
(10kHz step)

IHF Sensitivity: FM: 1.5 μ V
AM: 350 μ V

FM Stereo separation: 35dB

FM Signal to noise Ratio: 60dB

Antennas input: FM: 75ohms unbalanced
AM: Loop antenna and External ter-
minals

TAPE DECK SECTION

Cassette tape deck

Tape: Cassette tape

Tape Speed: 4.75cm/s

Recording System
and Bias Frequency: AC bias, 85kHz

Track System: 4 track 2 channel

Erasing System: AC erase

Frequency Responce: Normal: 70Hz to 14kHz
Metal: 70Hz to 14kHz

Signal-to-Noise Ratio: Dolby NR ON: 58dB
Dolby NR OFF: 50dB

Crosstalk: 65dB

Erase Ratio: 70dB

Motor: DC Motor

REMOTE CONTROLLER (RB-38)

Dimensions: 50 (H) × 158 (H) × 18 (D) mm

Weight: 110g

HT-MD28

Type	2-speed belt drive system	Cartridge	Moving Magnet
Platter	295mm diameter platter	Output voltage	2.5mV
Motor	DC motor	Crosstalk	25dB (1kHz)
Speed	2 speeds 33-1/3 and 45rpm	Load Impedance	47kohm 100pF
Signal to noise ratio	56dB (DIN-B)	Stylus tip	Diamond stylus
Wow and Flutter	0.07% (WRMS)	Power source	DC 12V (Secondary supply from HRD-MD38 or HRD-MD53)
Tonearm		Power consumption	3watts
Effective length	205mm	Dimensions	370 (W) × 89 (H) × 340 (D) mm
When a HITACHI cartridge is attached		Weight	3kg

Specifications and design may be changed without notice for improvement.

PRÉCAUTIONS DE SÉCURITÉ

Les précautions suivantes doivent être observées chaque fois qu'une réparation doit être faite.

1. Etant donné que de nombreux composants de l'appareil possèdent des caractéristiques relatives à la sécurité, utiliser uniquement des pièces de rechange d'origine Hitachi pour effectuer un remplacement. Ceci se rapporte notamment aux pièces critiques du bloc d'alimentation qui ne doivent en aucun cas être remplacées par celles d'autres fabricants. Les pièces critiques sont accompagnés du symbole \triangle dans le plan de circuit et sur le plan de base.
2. Avant de retourner l'appareil réparé au client le technicien doit procéder à un essai complet pour s'assurer qu'il ne présente aucun danger de chocs électriques.

FICHE TECHNIQUE

HRD-MD38

CARACTÉRISTIQUES GÉNÉRALES

Alimentation:	CA 240V 50Hz CA 220V 50Hz CA 110 - 120V, 200 - 220V, 230 - 240V, 50/60Hz (Appareil multi-tension)
Consommation:	180W 270W (pour W (UN))
Dimensions:	370 (L) × 246 (H) × 299 (P) mm
Poids:	7,6kg 9.1kg (pour W (UN))

SECTION AMPLIFICATEUR

Sortie audio:	30W (8 ohms, 1kHz, D.H.T. 0.7%) 50W (8 ohms, 1 kHz, T.H.D. 0.7%) (pour W (UN))
Commande de tonalité:	63Hz ± 10dB, 250Hz ± 10dB 1kHz ± 10dB, 4kHz ± 10dB 16kHz ± 10dB
Sensibilité et impédance d'entrée:	PHONO: 2,5mV/50kohms CD: 200mV/30kohms
Impédance de charge:	Enceintes: 8 à 16ohms Casque: 8ohms ou plus

SECTION RADIO

Système:	Superhétérodyne à 2 gammes FM/AM (sauf pour le modèle doté de la gamme GO), 3 gammes FM/PO/GO (pour le modèle doté de la gamme GO)
Gamme d'accord:	FM: 87,5 à 108MHz (paliers de 50kHz) AM (PO): 522 à 1611kHz (paliers de 9kHz) 530 à 1620kHz (paliers de 10kHz) (pour les appareils à tension multiple)

Sensibilité IEC:	FM: 1,5 μ V AM (PO, GO): 450 μ V
Séparation FM stéréo:	35dB
Rapport signal/bruit FM:	60dB
Entrée d'antennes:	FM: 75ohms non asymétriques AM (PO, GO): Bornes d'antenne-cadre et d'antenne extérieure

SECTION PLATINES CASSETTES

Platines cassettes	
Bande:	Bande cassette
Vitesse de bande:	4,75cm/s
Système d'enregistrement et fréquence de polarisation:	Polarisation CA, 85kHz
Système de piste:	4 pistes sur 2 canaux
Système d'effacement:	Effacement CA
Réponse de fréquence:	Normale: 70Hz à 14kHz Métal: 70Hz à 14kHz
Rapport signal/bruit:	Avec le Dolby NR: 58dB 56dB (pour W (UN)) Sans le Dolby NR: 50dB
Diaphonie:	65dB
Taux d'effacement:	70dB
Moteur:	Moteur CC
TÉLÉCOMMANDE (RB-38)	
Dimensions:	50 (L) × 158 (H) × 18 (P) mm
Poids:	110g

HRD-MD53

CARACTÉRISTIQUES GÉNÉRALES

Alimentation: CA 120V 60Hz
 Consommation: 180W
 Dimensions: 370 (L) × 246 (H) × 299 (P) mm
 Poids: 8,3kg

SECTION AMPLIFICATEUR

Sortie audio: 50watts par canal, min. RMS, à 8 ohms de 40Hz à 20kHz, avec une distorsion harmonique totale ne dépassant pas 0,9%.

Commande de tonalité: 63Hz ± 10dB
 250Hz ± 10dB
 1kHz ± 10dB
 4kHz ± 10dB
 16kHz ± 10dB

Sensibilité et impédance d'entrée: PHONO: 3mV/50kohms
 CD: 200mV/30kohms

impédance de charge: Enceintes: 8 à 16ohms
 Casque: 8ohms ou plus

SECTION RADIO

Système: Superhétérodyne a 2 gammes
 Gamme d'accord: FM: 87,9 à 107,9MHz (paliers de 100kHz)
 AM: 530 à 1620kHz (paliers de 10kHz)

Sensibilité IEC: FM: 1,5µV
 AM: 350µV

Séparation FM stéréo: 35dB
 Rapport signal/bruit FM: 60dB
 Entrée d'antennes: FM: 75 ohms non asymétriques
 AM: Bornes d'antenne-cadre et d'antenne extérieure

SECTION PLATINES CASSETTES

Platines cassettes
 Bande: Bande cassette
 Vitesse de bande: 4,75cm/s
 Système d'enregistrement et fréquence de polarisation: Polarisation CA, 85kHz
 Système de piste: 4 pistes sur 2 canaux
 Système d'effacement: Effacement CA

Réponse de fréquence: Normale: 70Hz à 14kHz
 Métal: 70Hz à 14kHz

Rapport signal/bruit: Avec le Dolby NR: 56dB
 Sans le Dolby NR: 50dB

Diaphonie: 65dB
 Taux d'effacement: 70dB
 Moteur: Moteur CC

TÉLÉCOMMANDE (RB-38)

Dimensions: 50 (L) × 158 (H) × 18 (P) mm
 Poids: 110g

HT-MD28

Type: Système 2 vitesses à commande par courroie
 Plateau: Plateau de 295mm de diamètre
 Moteur: Moteur CC
 Vitesse: 2 vitesses, 33-1/3 et 45tours
 Rapport signal/bruit: 56dB (DIN-B)
 Pleur et scintillement: 0,007% (WRMS)
 Bras de lecture: Longueur effective 205mm

Lorsqu'une cellule Hitachi est incorporée

Cellule: Aimant mobile
 Tension de sortie: 2,5mV
 Transmodulation: 25dB (1kHz)
 Impédance de charge: 45kohms 100pF
 Pointe de lecture: Diamant
 Source d'alimentation: CC 12V (alimentation secondaire provenant de HRD-MD38 ou HRD-MD53)

Consommation: 3watts
 Dimensions: 370 (L) × 89 (H) × 340 (P) mm
 Poids: 3kg

La conception et spécifications sont sujettes à modification sans préavis pour des raisons d'amélioration.

Check that exposed parts are acceptably insulated from the supply circuit before returning the instrument repaired to the customer.

● **Checking method**

Power switch is set to ON.
 Next, measure the resistance value between the both poles of attachment cup (Power supply plug) and the exposed parts (Parts such as Ground terminal, Knob, Cover, etc. where the customer is easy to touch.) and check that the resistance value is 500 kohms or more.

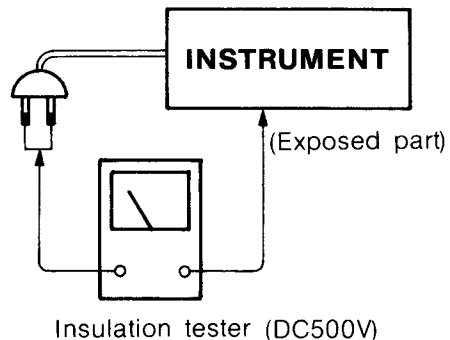

DISASSEMBLY

1. Removing the Top cover (Fig. 1)

- (1) Remove the 6 screws Ⓐ and 3 screws Ⓑ.

2. Removing the rear plate (Fig. 2)

- (1) After removing the Top cover, remove the 5 screws Ⓒ.

3. Removing the TD P.W.B. (Fig. 2)

- (1) After removing the rear plate, remove the 6 screws Ⓓ.
- (2) Disconnect the connectors and remove the REC spring.

4. Removing the Power P.W.B. (Fig. 3)

- (1) After removing the TD P.W.B., remove the 4 screws Ⓔ.
- (2) Disconnect the 5 connectors.

5. Removing the Front P.W.B.

- (1) Remove the 4 screws Ⓟ and Remove the Front Panel from the Chassis. (Fig. 3)
 - (2) Remove the 1 screw Ⓠ, REC Lever (B) and REC wire. (Fig. 4)
- In case of HRD-MD38 for W (UN) only
 - (2) Remove the 1 screw Ⓠ and REC lever. (Fig. 5)
 - (3) Remove the 12 screws Ⓡ. (Fig. 4)

6. Removing the SW P.W.B.

- (1) Remove the 2 screws Ⓒ. (Fig. 4)
- In case of HRD-MD38 for W (UN) only
 - (1) Remove the 2 screws Ⓢ with REVERSE HOLDER. (Fig. 5)
 - (2) Remove the 2 screws Ⓒ.

7. Removing the G.EQ P.W.B. (Fig. 6)

- (1) Remove the 4 screws Ⓣ.
- (2) Remove the 6 Knobs.
- (3) Release the 3 claws.

8. Removing the Vol P.W.B. (Fig. 6)

- (1) Remove 2 screws Ⓤ.
- (2) Remove the Volume knob.

9. Removing the key P.W.B. (Fig.6)

- (1) Remove the 1 screw Ⓥ.
- (2) Release the 3 claws.

10. Removing the cassette deck chassis.

- (1) Remove the 7 screws Ⓧ. (Fig. 6)
- In case of HRD-MD38 for W (UN) only
 - (1) Remove the 8 screws Ⓧ.

DEMONTAGE

1. Dépose du couvercle supérieur (Fig. 1)

- (1) Desserrer les 6 vis Ⓐ et les 3 vis Ⓑ.

2. Dépose de la plaque arrière (Fig. 2)

- (1) Après avoir enlevé le couvercle supérieur, desserrer les 5 vis Ⓒ.

3. Dépose de la PCI TD (Fig. 2)

- (1) Après avoir enlevé la plaque arrière, desserrer les 6 vis Ⓓ.
- (2) Enlever les connecteurs et déposer le ressort REC.

4. Dépose de la PCI d'alimentation (Fig. 3)

- (1) Après avoir enlevé la PCI TD, desserrer les 4 vis Ⓔ.
- (2) Dégager les 5 connecteurs.

5. Enlèvement de la PCI avant

- (1) Desserrer les 4 vis Ⓟ et enlever du châssis le panneau avant (Fig. 3).
 - (2) Enlever la vis Ⓠ, le levier REC et le fil REC (Fig. 4).
- Dans le cas de HRD-MD38 pour W (UN) seulement
 - (2) Enlever la vis Ⓠ et levier REC (Fig. 5).
 - (3) Desserrer les 12 vis Ⓡ. (Fig. 4)

6. Dépose de la PCI SW

- (1) Desserrer 2 vis Ⓒ. (Fig. 4)
- Dans le cas de HRD-MD38 pour W (UN) seulement
 - (1) Enlever les 2 vis Ⓢ avec le support d'inversion. (Fig. 5)
 - (2) Desserrer les 2 vis Ⓒ.

7. Dépose de la PCI G.EQ (Fig. 6)

- (1) Desserrer les 4 vis Ⓣ.
- (2) Enlever les 6 boutons.
- (3) Libérer les 3 crochets.

8. Dépose de la PCI de vol (Fig. 6)

- (1) Desserrer les 2 vis Ⓤ.
- (2) Enlever le bouton de volume.

9. Dépose de la PCI de touches (Fig. 6)

- (1) Desserrer la vis Ⓥ.
- (2) Libérer les 3 crochets.

10. Dépose du châssis de platine cassette

- (1) Desserrer les 7 vis Ⓧ (Fig. 5).
- Dans le cas de HRD-MD38 W (UN) seulement
 - (1) Desserrer les 8 vis Ⓧ.

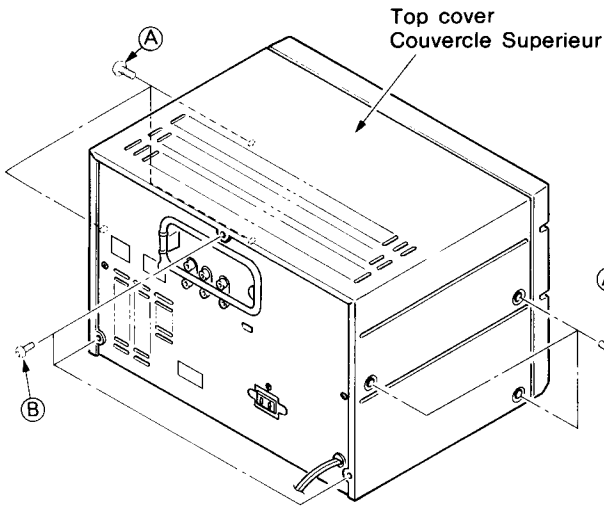

Fig. 1

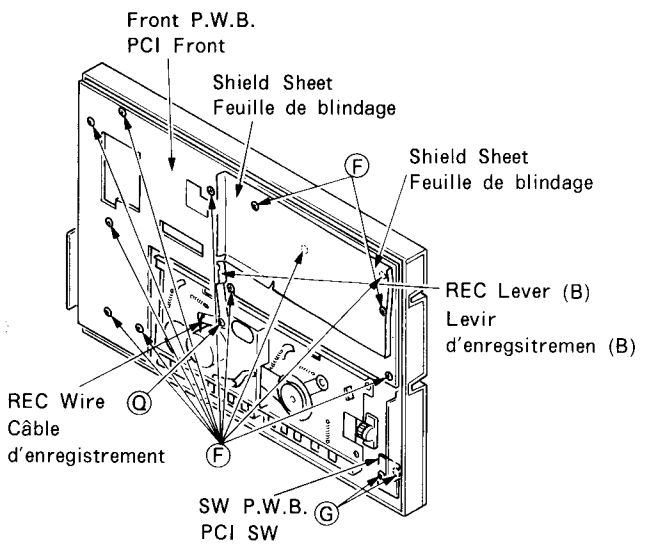

Fig. 4

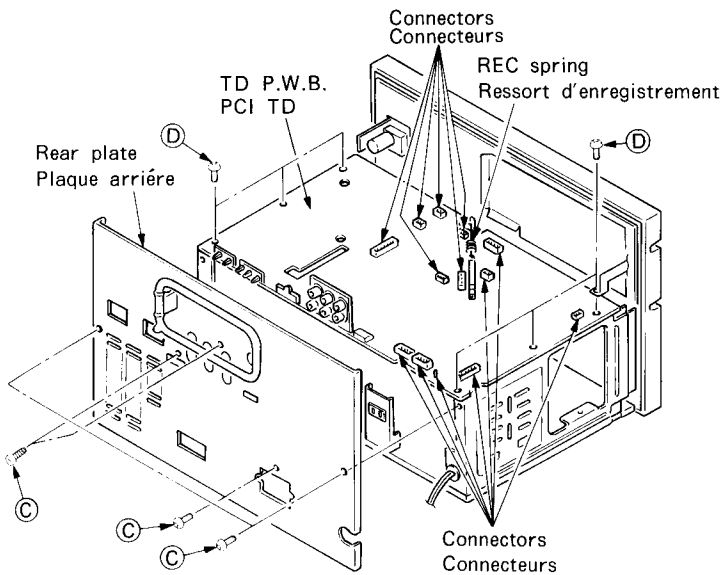

Fig. 2

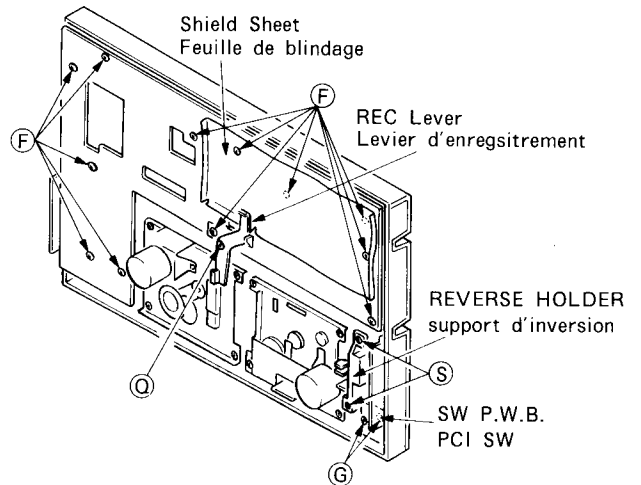

Fig. 5

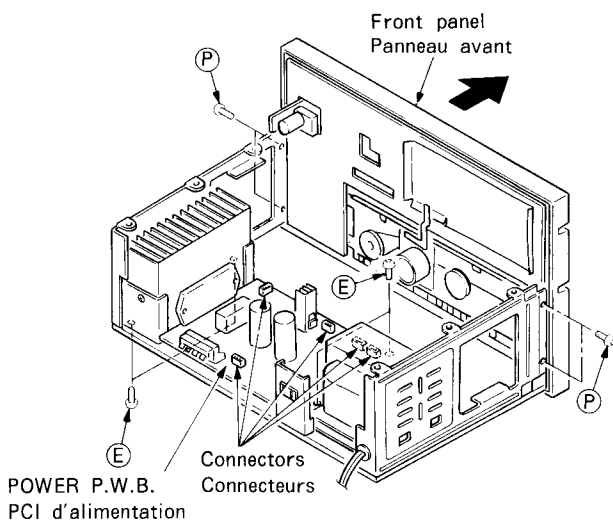

Fig. 3

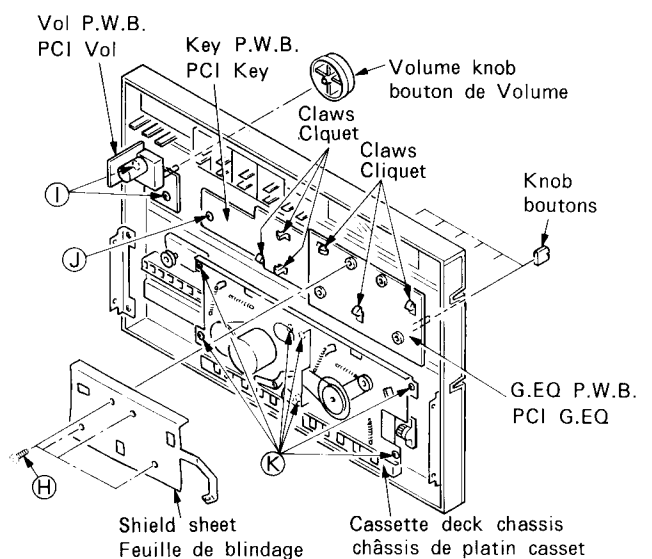
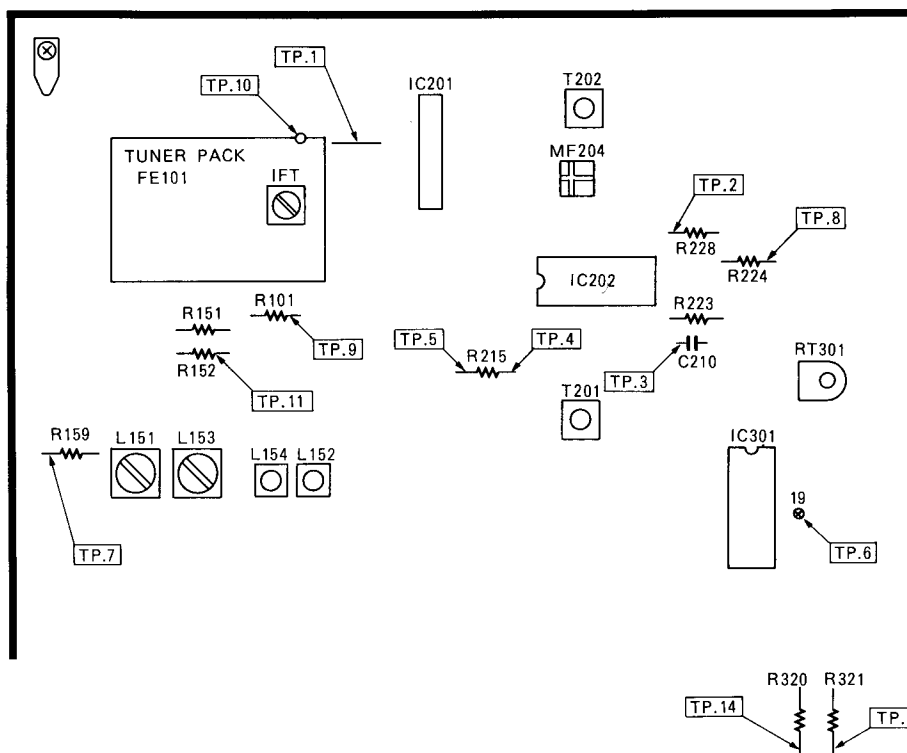

Fig. 6

ADJUSTMENT • REGLAGE

1. RADIO SECTION • SECTION RADIO



FM Section • Section MF

FUNCTION: Tuner (FM)
FUNCTION: Tuner

VOLUME: MIN
VOLUME: min.

FM MODE: MONO

Sweep Generator
Générateur de balayage

Signal Generator
Générateur de signaux

Oscilloscope
Oscilloscope

+ DC Null Meter
Indicateur d'équilibrage
à C. C.

VTVM
Voltmètre électronique

Frequency Counter
Fréquence-mètre

Dist.
 Distortion Meter
Distorsion-mètre

Sequence Ordre	Connection Connexion		Setting Montage		Adjust for Réglage pour	
	Input Entrée	Output Sortie	Tuning Indicateur d'accord	Signal Signal	Adjust Réglage	Indication Indication
1		IN Entrée TP.2 100K 0.1µ	—	10.7MHz	FM IFT (Tuner Pack) (Ensemble Tuner)	(Note 2)
2	Out Sortie TP.1 0.1µ 100K	IN Entrée TP.3 100K 0.1µ	—	10.7MHz	T201	Straight line Ligne droite (Note 3)

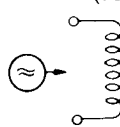
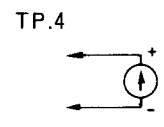
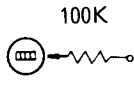
3	Discriminator Discriminateur	<p>ANT. Terminal (75 ohms)</p>  <p>1kHz, 60dBμ 75kHz (dev.) (for U.S.A. Canada) 40kHz (dev.) (except U.S.A. Canada)</p>	<p>TP.4</p>  <p>TP.5</p>	98.1 or 98.00MHz	98.1 or 98.00MHz	T201	(Note 4)
4	Covering Portée	—					(Note 5)
5	Tracking Alignement	—					(Note 5)
6	19kHz (FM MODE: AUTO)	<p>ANT. Terminal (75) ohms 60dBμ Non modulated Sans modulation</p>	<p>100K</p>  <p>TP.6</p>	98.1 or 98,00MHz	98.1 or 98.00MHz	RT301	19kHz \pm 50Hz

- **(Note 1)**
Perform adjustment at least 3 minutes after the power has been switched on.
- **(Note 2)**
Using a sweep generator, apply low-input signals (with a small amount of noise superimposed as in fig. A), and adjust the FM IFT so that the waveforms are brought to their maximum in center marker frequency (10.7 MHz).
- **(Note 3)**
Adjust the T201 coil and obtain an S-curve.
- **(Note 4)**
Connect a DC null meter and adjust T201 for a reading of 0V \pm 30 mV.
- **(Note 5)**
FM Tuner pack is aligned before shipping, so it is not necessary to adjust covering and tracking.

- **(Note 1)**
Effectuer ce réglage au moins 3 minutes après la mise sous tension.
- **(Note 2)**
Utiliser un générateur de balayage et appliquer des signaux d'entrée à faible niveau (avec un faible chevauchement de bruit comme représenté sur la Fig. A), et ajuster FM IFT pour amener les formes d'ondes à leur maximum de la fréquence nominale de repérage (10,7 MHz).
- **(Note 3)**
Ajuster la bobine T201 pour obtenir une courbe en forme de "S".
- **(Note 4)**
Raccorder un indicateur de zéro à courant continu et ajuster le T201 pour obtenir une lecture de 0V \pm 30 mV.
- **(Note 5)**
L'étage tuner FM est réglé avant son envoi, il est donc inutile d'effectuer le réglage de portée et d'alignement.

AM Section · Section MA

Condition: Function: TUNER (AM)
Modulation: 400Hz 30%

Conditions: Fonction: TUNER
Modulation: 400Hz 30%

Sequence Ordre	Connection Connexion		Setting Montage		Adjust for Réglage pour	
	Input Entrée	Output sortie	Tuning Indicateur d'accord	Signal	Adjust Réglage	Indication indication
1	Out Sortie 0.1µ 100K	TP.3 IN Entrée 100K 0.1µ		450kHz	T202	MAX Caution 1 Attention 1
2		TP.9 GND 	530kHz or 522kHz	—	L152	530kHz: 1.25VDC 522kHz: 1.2VDC Caution 2 Attention 2
3		SP OUT or AM IF OUT 	600kHz or 603kHz	600kHz or 603kHz	L151	Output max. Caution 3 Attention 3
4		TP.11 GND 	146kHz	—	L154	146kHz 1.2V Caution 2 Attention 2
5		SP OUT or AM IF OUT 	164kHz	164kHz	L153	Output max. Caution 3 Attention 3

Caution

1. Adjust T202 so that the waveform is as shown in Fig. B. After adjusting as above, increase the output level of the sweep generator and adjust T202 again so that the top of the waveform A (indicated in Fig. C) will be flat and wide.
2. Carry out this adjustment for final adjustment of the coil only when you have moved the core by mistake.
3. Set the input level to 74 dB/m in coarse adjustment. Reduce the input level to minimum (50 dB/m) as adjustment proceeds.

Attention

1. Régler T202 de façon à obtenir une forme d'onde comme indiquée sur la Fig. B. Après avoir réglé comme indiqué ci-dessus, augmenter le niveau d'entrée du générateur de balayage et régler T202 à nouveau de façon que le sommet de la forme d'onde A (voir Fig. C) soit aplati et large.
2. N'effectuer le dernier réglage de la bobine par ce réglage que si vous avez bougé l'âme par erreur.
3. Faire un réglage approximatif du niveau d'entrée à 74 dB/m. Réduire le niveau d'entrée jusqu'à un minimum de 50 dB/m à mesure que l'on effectue réglage.

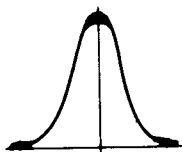

Fig. A

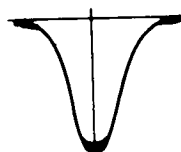

Fig. B

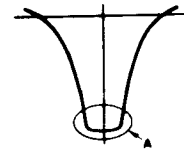
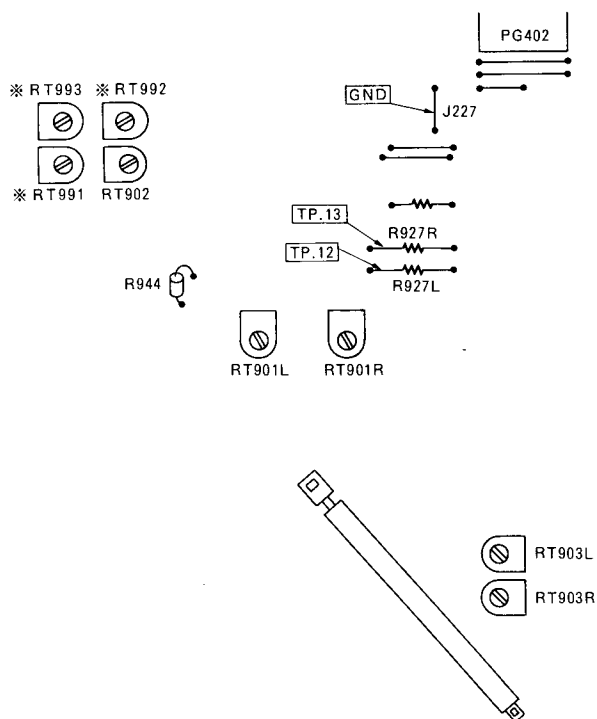

Fig. C

2. TAPE DECK SECTION

• Adjust points

* RT991, 992, 993 : HRD-MD38W(UN) set only



Caution

- Unless otherwise specified, set the switches as follows before adjustment.
- Clean the head capstan and pressure roller with alcohol and then proceed to adjustment in the following order.

1-1 Tape speed adjustment

- (1) Connect a frequency counter to TP 12 or TP 13. With TAPE 1 or TAPE 2, play back about the middle of test tape MTT-111 and adjust RT 902 so as to obtain $3,000 \text{ Hz} \pm 20 \text{ Hz}$.
- (2) Make sure of $6,000 \text{ Hz} \pm 300 \text{ Hz}$ when the lead of R994 is shorted to GND.

1-2 Tape speed adjustment

This adjustment is in case of HRD-MD38 W (UN) set only.

- (1) Connect the frequency counter to TP 12 or TP 13.
- (2) Short the lead of R944 to GND. With TAPE 1, play back about the middle of test tape MTT-111 and adjust RT 993 to obtain $6,000 \text{ Hz} \pm 20 \text{ Hz}$ (adjustment of High speed mode). Then remove the short-circuit between the lead of R944 and GND and adjust RT 992 to obtain $3,000 \text{ Hz} \pm 20 \text{ Hz}$ (adjustment of Normal speed mode).
- (3) With TAPE 2 also, perform adjustment for High speed mode by RT 991, and for Normal speed mode by RT 902.

2. Head azimuth adjustment

- (1) Connect AC voltmeter to TP 12 or TP 13, play back the test tape MTT-114 (10 kHz) and adjust the head angle adjusting screw so the output is a maximum. If L and R channel peaks are different, retain L channel peak as main (at this time, the difference in peak between both channels must be 2 dB max.). Perform this adjustment for both TAPE 1 and 2. After adjustment, apply screw lock.

3. Recording level adjustment

- (1) Connect AC voltmeter to TP 12 or TP 13. Connect a generator to CD INPUT and apply a sine wave of 1 kHz. Set the deck to a recording status and adjust the generator output so the output at TP 12 or TP 13 is $300 \text{ mV} - 25 \text{ dB}$.
- (2) Perform recording and playback and adjust RT 901LR so the output at TP 12 or TP 13 is $300 \text{ mV} - 25 \text{ dB} \pm 3 \text{ dB}$.

4. Bias current adjustment

- (1) Set RT 903LR at about the middle (coarse adjustment).
- (2) By Lo-D UDR tape, record and play back a signal of 400 Hz and a signal of 10 kHz at a level of $300 \text{ mV} - 25 \text{ dB}$. Adjust RT 903LR so the output of 10 kHz is 0 to +1 dB with respect to the output of 400 Hz.
- (3) Record the signal of 400 Hz at a level of $300 \text{ mV} - 10 \text{ dB}$. Make sure a played back output is $300 \text{ mV} - 10 \text{ dB} \pm 2 \text{ dB}$.

5. Dolby check

- (1) At a recording status, apply a sine wave of 5 kHz to CD INPUT and adjust to $300 \text{ mV} - 30 \text{ dB}$ the voltage between test points TP 12 or TP 13 and GND.
- (2) Make sure the voltage between TP 12 or TP 13 and GND is $-21.8 \text{ dB} \pm 2 \text{ dB}$ when DOLBY switch is turned on.

2. SECTION MAGNETOCASSETTE

• Points de réglage

* RT991, 992, 993 : HRD-MD38W(UN) seulement

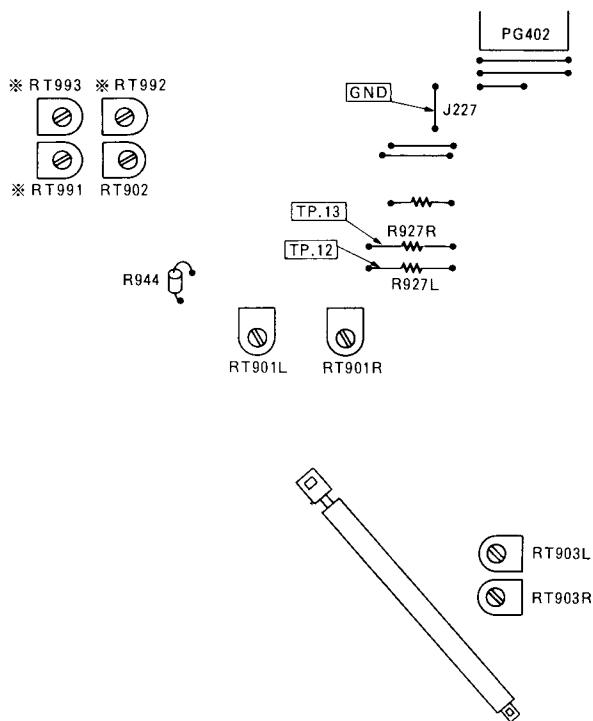

Précautions

- Sauf indications contraires, mettre les commandes comme indiqué ci-dessous avant de procéder au réglage.
- Nettoyer le cabestan de tête et le rouleau preneur avec de l'alcool et puis effectuer le réglage dans l'ordre suivant.

1-1 Réglage de la vitesse de bande

- (1) Relier un fréquencemètre sur TP 12 ou TP 13. Avec TAPE (bande) 1 ou TAPE 2, reproduire environ le milieu de la bande d'essai MTT-111 et régler RT 902 de manière à obtenir 3.000 Hz \pm 20 Hz.
- (2) S'assurer de 6.000 \pm 300 Hz quand le fil de R944 est court-circuité à la terre.

1-2 Réglage de la vitesse de bande

N'effectuer ce réglage que pour l'appareil HRD-MD38 W (UN).

- (1) Relier le fréquencemètre sur TP 12 ou TP 13.
- (2) Court-circuiter le fil de R944 avec GND. Avec TAPE 1, reproduire environ le milieu de la bande d'essai MTT-111 et régler RT 993 de manière à obtenir 6.000 Hz \pm 20 Hz (réglage du mode de vitesse élevée). Puis enlever le court-circuitage entre le fil de R944 et GND et régler RT 992 pour obtenir 3.000 Hz \pm 20 Hz (réglage du mode de vitesse normale).
- (3) Avec TAPE 2 également, effectuer le réglage pour le mode de vitesse élevée au moyen de RT 991, et pour le mode de vitesse normale au moyen de RT 902.

2. Réglage de l'azimut de tête

- (1) Relier le voltmètre CA sur TP 12 ou TP 13, reproduire la bande d'essai MTT-114 (10 kHz) et régler la vis régulatrice d'angle de tête de sorte que la sortie soit maximale.
Si les crêtes de canaux L et R sont différentes, retenir la crête de canal L comme référence (dans ce cas, la différence en crête entre les deux canaux doit être de 2 dB max.)
Effectuer ce réglage pour TAPE 1 et 2 toutes les deux. Après le réglage, appliquer du "screw lock".

3. Réglage du niveau d'enregistrement

- (1) Relier le voltmètre CA sur TP 12 ou TP 13. Brancher le générateur sur CD INPUT et appliquer une onde sinusoïdale de 1 kHz. Mettre la platine à l'état d'enregistrement et régler la sortie de générateur de sorte que la sortie de générateur sur TP 12 ou TP 13 soit de 300 mV - 25 dB.
- (2) Effectuer un enregistrement et une lecture et régler RT 901LR de façon que la sortie sur TP 12 ou TP 13 soit de 300 mV - 25 dB \pm 3 dB.

4. Réglage du courant de polarisation

- (1) Mettre RT 903LR environ sur le milieu (gros réglage).
- (2) Par la bande Lo-D UDR, enregistrer et reproduire un signal de 400 Hz et un signal de 10 kHz au niveau de 300 mV - 25 dB. Régler RT 903LR de sorte que la sortie de 10 kHz soit de 0 à + 1 dB par rapport à la sortie de 400 Hz.
- (3) Enregistrer le signal de 400 Hz au niveau de 300 mV - 10 dB. S'assurer que la sortie reproduite est de 300 mV - 10 dB \pm 2 dB.

5. Contrôle Dolby

- (1) A l'état d'enregistrement, appliquer une onde sinusoïdale de 5 kHz sur CD INPUT et régler à 300 mV - 30 dB la tension entre le point d'essai TP 12 ou TP 13 et GND.
- (2) S'assurer que la tension entre TP 12 ou TP 13 et GND est de - 21,8 dB \pm 2 dB quand l'interrupteur

3. TURNTABLE SECTION · SECTION PLATINE (HT-MD28)

1. Speed adjustment (Fig. 6)

If the specified speed cannot be obtained after replacing the motor, use the stroboscopic disc. (Adjustment is possible without removing the bottom plate.)

Note:

Before adjustment, perform more than 10 minutes warmup with the turntable at 33 1/3 rpm.

Carry out this adjustment in the order of (1) and (2).

- (1) Set the speed to 33 1/3 rpm, and adjust (A) so as to obtain the rated speed (33 1/3 rpm).
- (2) Set the speed to 45 rpm, and adjust (B) so as to obtain the rated speed (45 rpm).

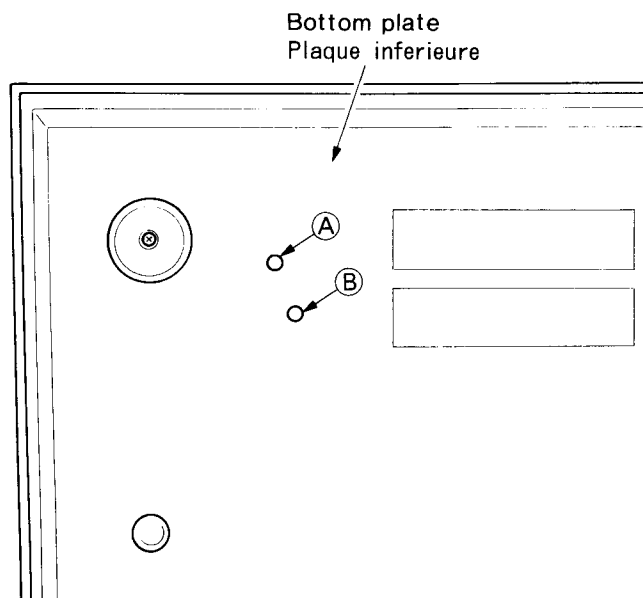

Fig. 6

1. Réglage de la vitesse (Fig. 6)

Si la vitesse prévue ne peut être obtenue après avoir remplacé le moteur, utiliser le disque stroboscopique. (Réglage est possible sans enlever la plaque de fond.)

Note:

Avant le réglage, effectuer un préchauffage au moins 10 minutes la table tournante étant à 33 1/3 tr/mn.

Procéder à ce réglage dans l'ordre de (1) et (2).

- (1) Mettre la vitesse sur 33 1/3 tr/mn et régler (A) de manière à obtenir la vitesse nominale (33 1/3 tr/mn).
- (2) Mettre la vitesse sur 45 tr/mn et régler (B) de manière à obtenir la vitesse nominale (45 tr/mn).

INSPECTION OF MECHANISM · INSPECTION DU MECANISME

Item	Checking item		Reference value	Remarks
1	Pressure of pressure roller		300 – 500 g	Note
2	Take-up torque		30 – 60 g · cm	
3	Fast forward/Rewind torque		50 g · cm or more	
4	Auto-Stop sensor operation force		40 – 75 g	
5	Brake torque		15 g · cm or more	Measured in stop mode
6	Back tension torque	Take-up	1 – 6 g · cm	
		Supply	1 – 4 g · cm	
7	Flywheel thrust gap		0.05 – 0.5 mm	
8	Button operation force	Play button	1.1 kg or less	
		FF button	0.8 kg or less	
		Rewind button	1.1 kg or less	
		Eject button	0.6 kg or less	
		Record button	1.0 kg or less	
		Pause button	1.0 kg or less	

Point	Poste de vérification		Valeur de référence	Remarques
1	Pression du galet-presseur		300 – 500 g	Remarque
2	Couple d'enroulage		30 – 60 g • cm	
3	Couple d'avancée rapide/rembobinage rapide		50 g • cm ou plus	
4	Effort à l'utilisation du détecteur pour arrêt automatique		40 – 75 g	
5	Couple de freinage		15 g • cm ou plus	Mesuré en mode d'arrêt
6	Couple de tension de recul	Enroulage	1 – 6 g • cm	
		Alimentation	1 – 4 g • cm	
7	Intervalle de poussée du volant		0,05 – 0,5 mm	
8	Effort à l'utilisation des touches	Touche de reproduction	1,1 kg ou moins	
		Touche d'avancée rapide	0,8 kg ou moins	
		Touche de rembobinage	1,1 kg ou moins	
		Touche d'éjection	0,6 kg ou moins	
		Touche d'enregistrement	1,0 kg ou moins	
		Touche de pause	1,0 kg ou moins	

Note:

Set this unit in the playback mode and press the pressure roller in the direction of the arrow using a fan type tension gauge, and measure the pressure when the pressure roller is released from the capstan.

Remarque:

Placez cet appareil en mode de reproduction, appuyez sur le galet-presseur dans le sens de la flèche à l'aide d'un calibre de tension type éventail, et mesurez la pression lorsque le galet-presseur est libéré du cabestan.

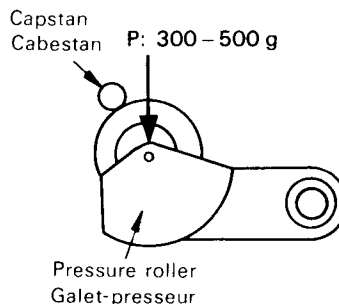

LUBRICATION

Lubricate one or two drops of oil to rotating point or lubricate grease to sliding point.
Lubricate the respective parts listed once every 1000 hours or once a year under normal conditions of use.
Avoid oiling them excessively, or rotation may become irregular because of oil splashes.

Lubrication point		Oil or Grease
Rotary section	Metal and metal	Pan motor oil (10W-40)
	Mold and metal	Sonic slider oil (# 1600)
Sliding section	Metal and metal	Hitasol (MO-138)
	Mold and mold	White grease (FL-LUBE-A)
	Mold and metal	White grease (FL-LUBE-A)
Spring resonance prevention		Floil (GB-TS-1)

LUBRIFICATION

Lubrifiez d'une ou deux gouttes d'huile au point de rotation ou lubrifiez de graisse le point de glissement.
Lubrifiez les pièces respectives énumérées toutes les 1000 heures ou une fois par an lors d'un usage normal de l'appareil.
Évitez une lubrification excessive, car le mouvement rotatif serait perturbé par les éclaboussures d'huile.

Point de lubrification		Huile ou graisse
Section rotative	Métal et métal	Huile de moteur PAN (10W-40)
	Métal et moulé	Huile de curseur sonic (# 1600)
Section glissante	Métal et métal	Hitasol (MO-138)
	Moulé et moulé	Graisse blanche (FL-LUBE-A)
	Moulé et métal	Graisse blanche (FL-LUBE-A)
Prévention de résonance du ressort		Floil (GB-TS-1)

CIRCUIT DIAGRAM DIAGRAMME DES CIRCUITS

※ : Axial lead cylindrical
※ : Condensateur céramique

TD P.W.B. (1/2)

⇌ FM ← AM ⇌ AUDIO

Voltage: FM MODE
() Voltage: AM MODE
<> Voltage: LW MODE

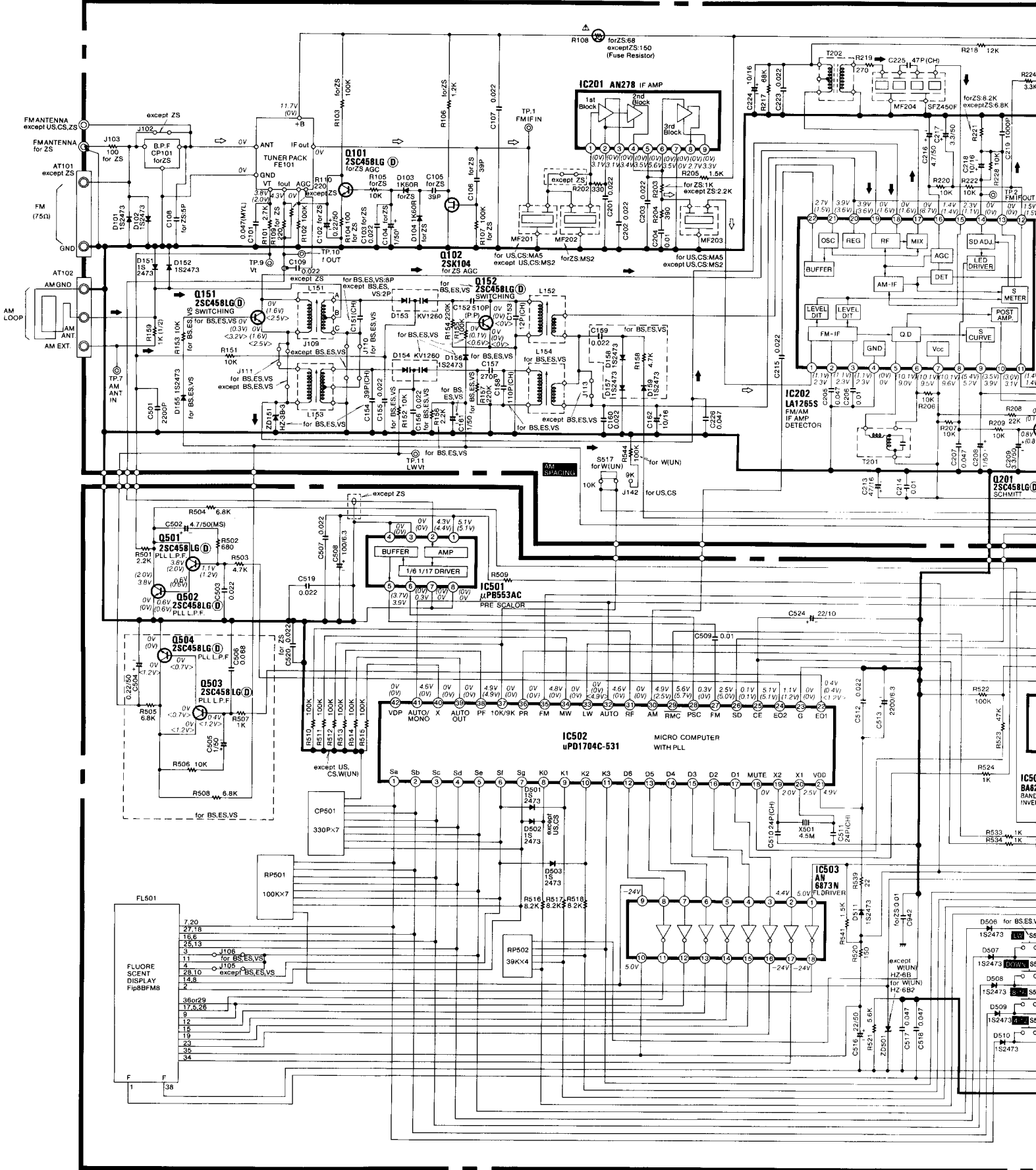

FRONT P.W.B. (1/7)

※ : Axial lead cylindrical ceramic capacitor
 ※ : Condensateur céramique cylindrique à conducteur axial

CAUTION
 Use the electrolytic capacitors with explosion-proof vent when the diameter of them is more than 10mmø.

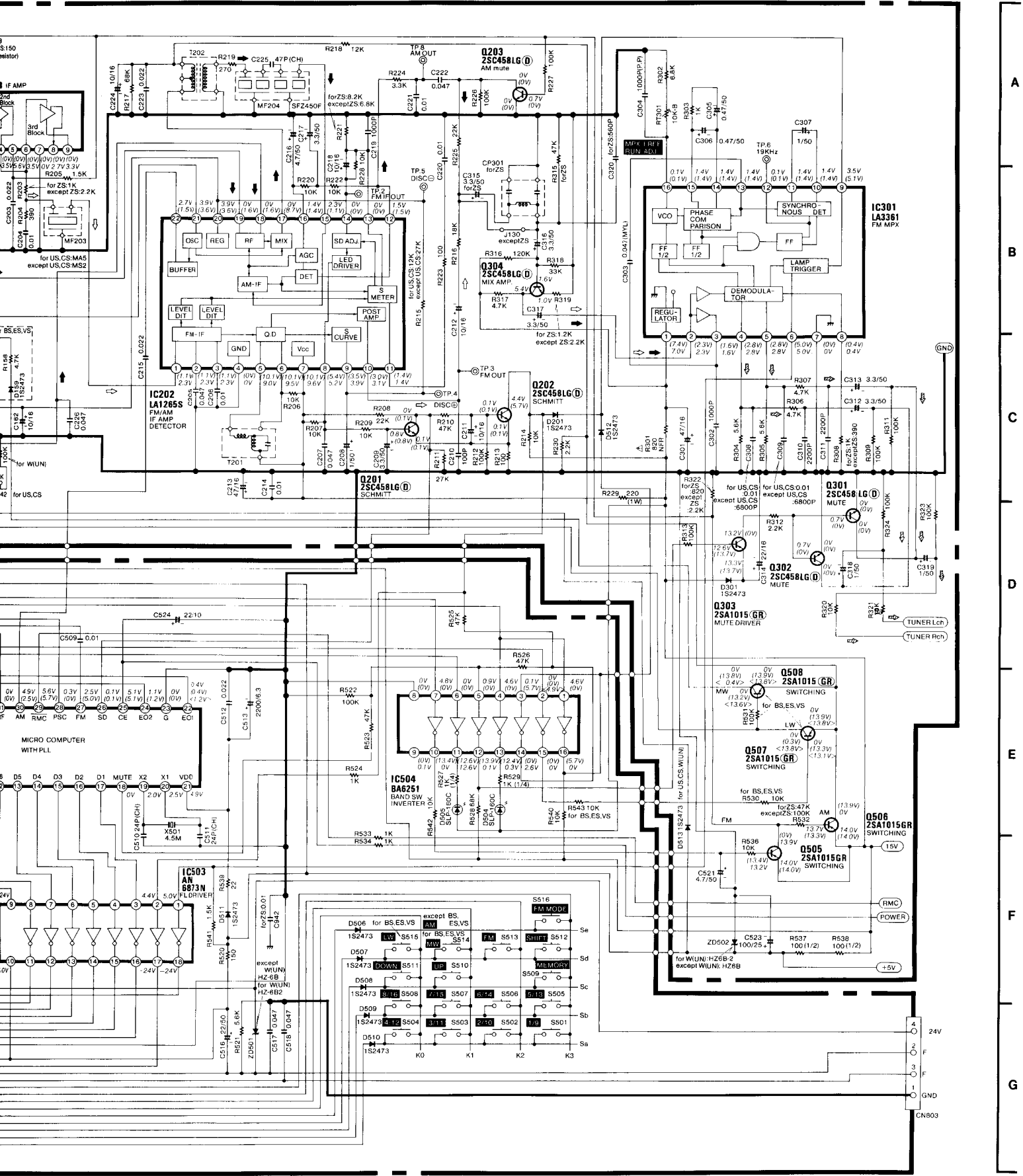

TD P.W.B. (2/2) [for W(UN)]

TAPE PLAY TAPE REC AUDIO(L) CH AUDIO(R) CH Voltage TAP1 9.4V (MUT) Voltage TAP2 REC/MUTE Voltage STBY MODE

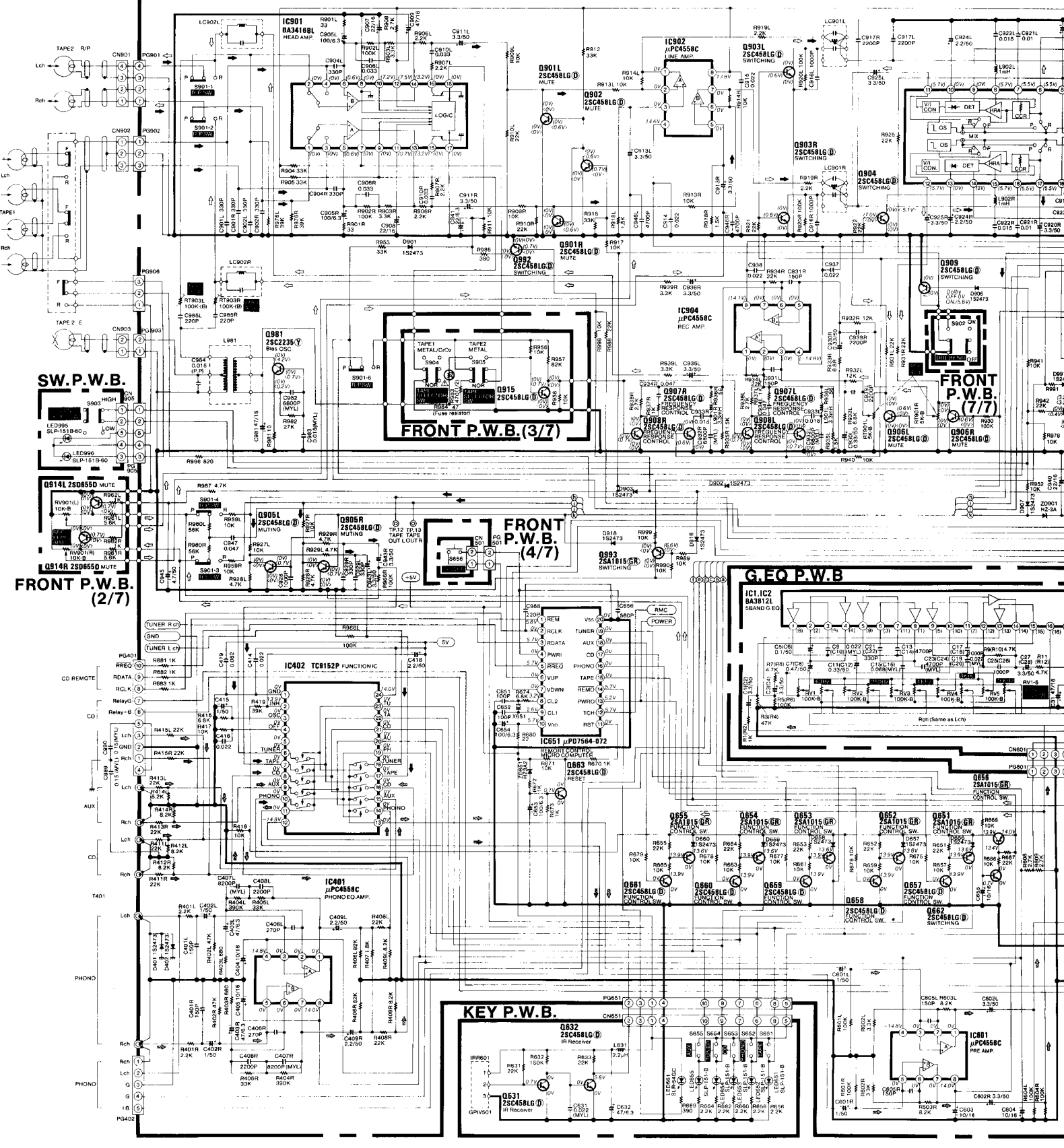

TD P.W.B. (2/2) [except W(UN)]

() Voltage TAPE PLAY MODE
() Voltage TAPE REC MODE
() Voltage STOP MODE

→ TAPE PLAY ← TAPE REC ← AUDIO (L ch) ← AUDIO (R ch)

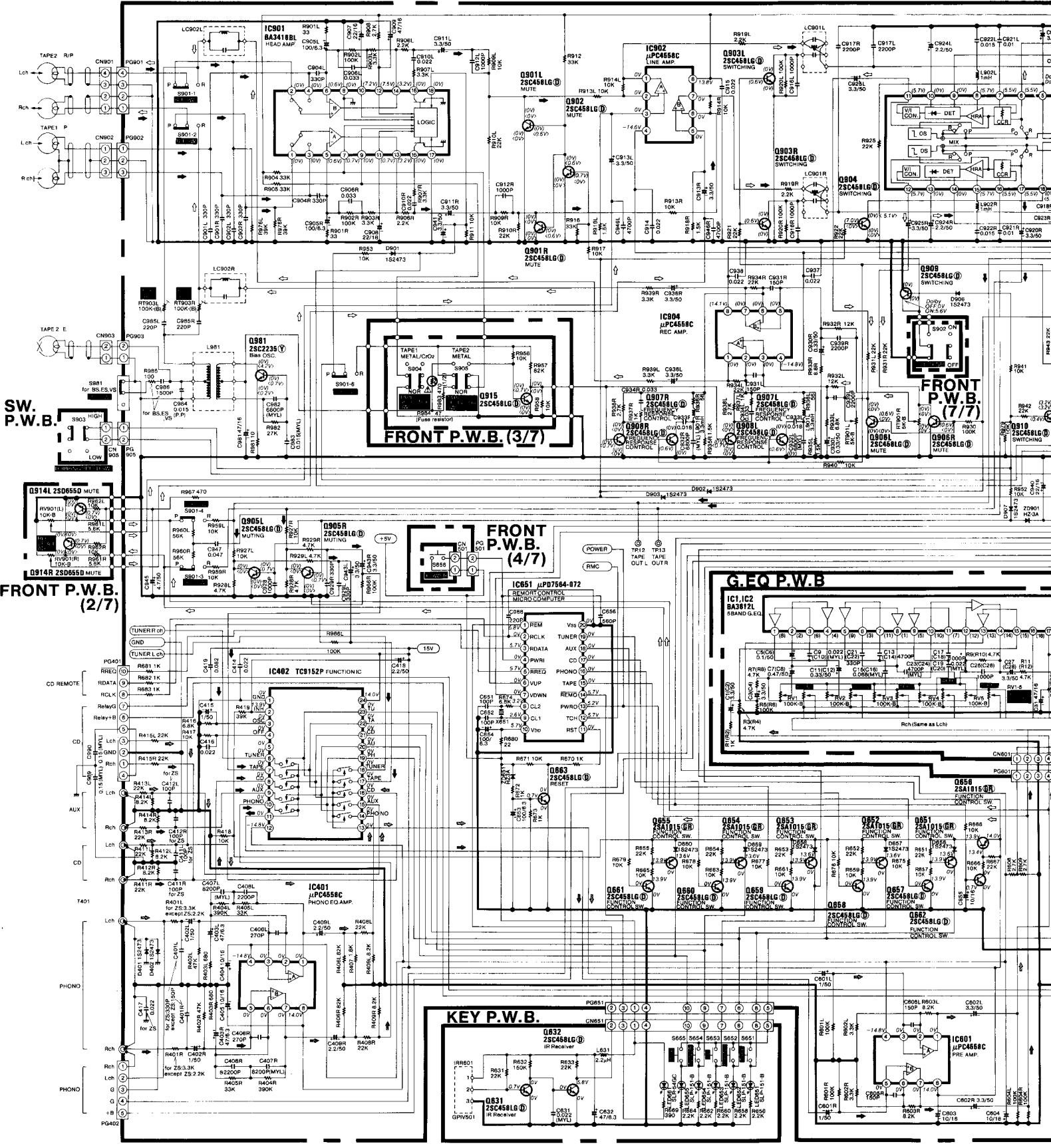

SW. P.W.B.

FRONT P.W.B. (2/7)

FRONT P.W.B. (3/7)

FRONT P.W.B. (4/7)

G.E.Q. P.W.B.

KEY P.W.B.

FRONT P.W.B. (7/7)

- ※: Axial lead cylindrical ceramic capacitor
- ※: Condensateur céramique cylindrique à conducteur axial

CAUTION
Use the electrolytic capacitors with explosion-proof valve when the diameter of them is more than 10mmφ.

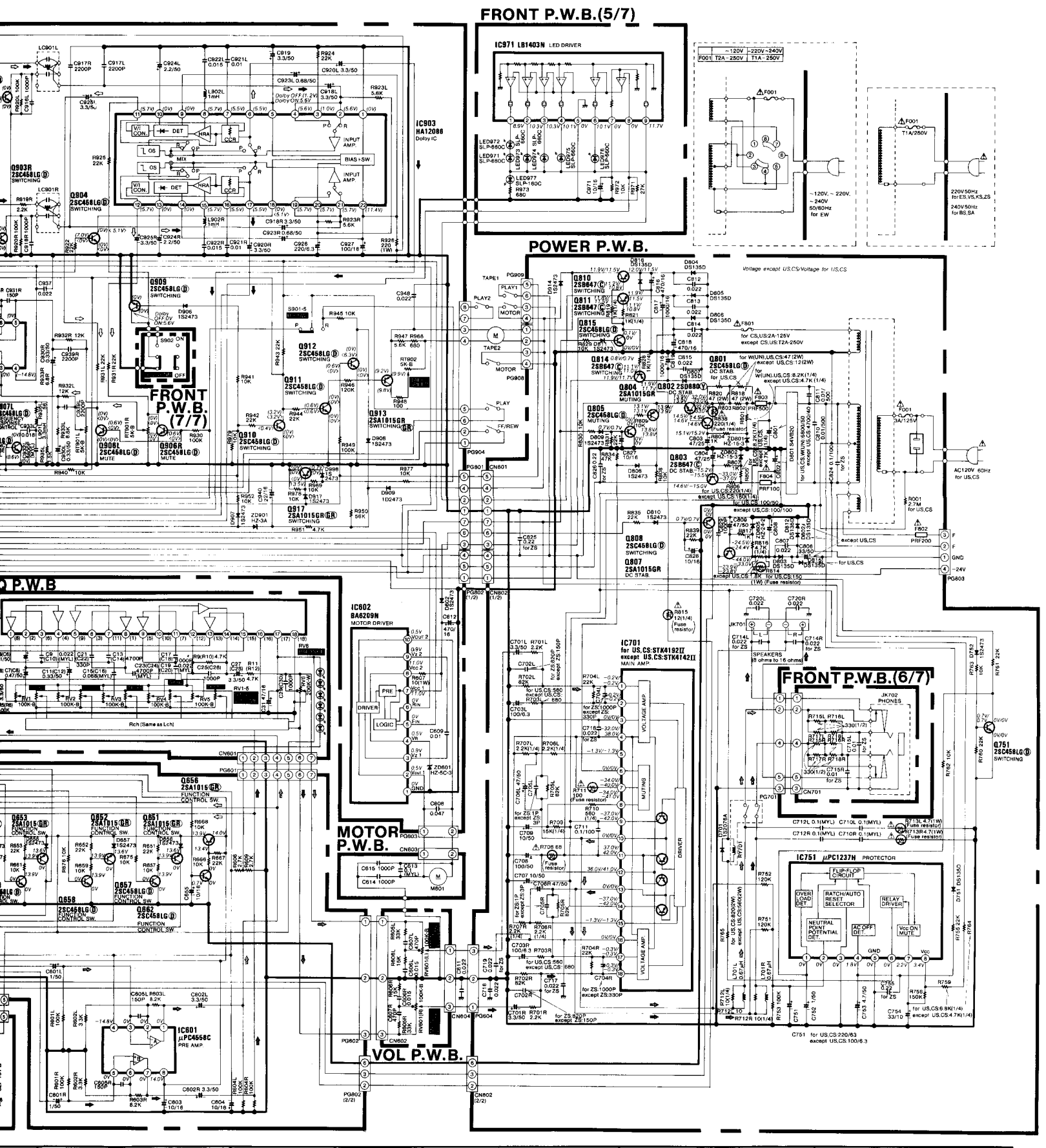

※: Axial lead cylindrical ceramic capacitor
※: Condensateur céramique cylindrique à conducteur axial

[ : Earth,  : Other]

for ES, VS, KS, ZS

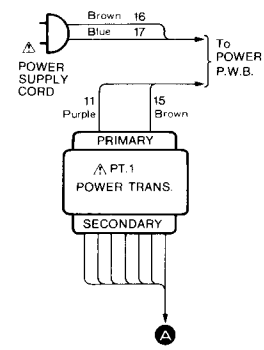

for EW, W(U)N

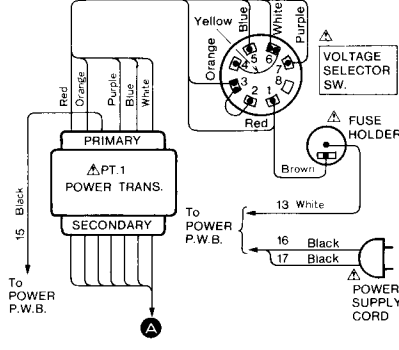

for US, CS

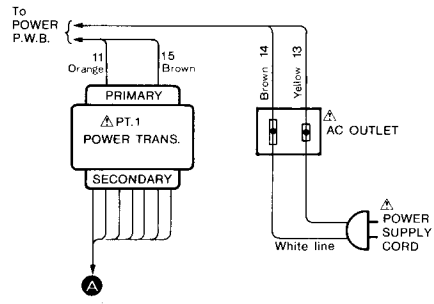

for BS, SA

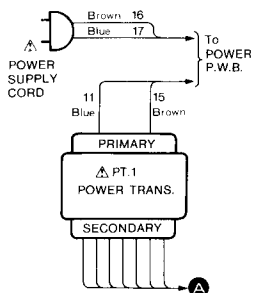

Voltage for U.S.CS/W(U)N/Voltage except U.S.CS/W(U)N

Q751	E 0V/0V	Q801	E 14.6V/14.5V
C 0V/0V	C 33V/32V	C 0V/0V	C -37V/-33V
B 0.7V/0.7V	B 15.2V/15.1V	B 15.2V/15.1V	B 15.5V/15.2V
Q802	E 13.9V/13.9V	Q803	E -16.0V/-14.6V
C 33V/32V	C 33V/32V	C -37V/-33V	C -37V/-33V
B 14.6V/14.5V	B 15.5V/15.2V	B 15.5V/15.2V	B 15.5V/15.2V
Q804	E 13.9V/13.9V	Q805	E 0V/0V
C 13.8V/13.1V	C 0V/0V	C 0V/0V	C 0V/0V
B 13.1V/13.8V	B 0.7V/0.7V	B 0.7V/0.7V	B 0.7V/0.7V
Q807	E -23.8V/-23.9V	Q808	E 0V/0V
C 38V/-44V	C 0V/0V	C 0V/0V	C 0V/0V
B -24.4V/-24.5V	B 0.7V/0.7V	B 0.7V/0.7V	B 0.7V/0.7V
Q810	E 11.5V/12.0V	Q815	E 0V/0V
C 11.5V/11.9V	C 0V/0V	C 0V/0V	C 0V/0V
B 10.8V/11.2V	B 0.7V/0.8V	B 0.7V/0.8V	B 0.7V/0.8V
Q811	E 11.5V/11.9V	Q816	E 11.5V
C 11.5V/11.8V	C 11.5V	C 11.5V	C 11.5V
B 10.8V/11.1V	B 10.8V	B 10.8V	B 10.8V
Q814	E 11.7V/11.9V	IC701	1 -0.2V/0.2V
C 11.7V/11.9V	C 0V/0V	2 -0.2V/-0.2V	2 0V/0V
B 11.0V/11.1V	B 0V/0V	3 0V/0V	3 0V/0V
IC701	4 -32V/-38V	4 -32V/-38V	4 -32V/-38V
5 -1.3V/-1.3V	5 -1.3V/-1.3V	5 -1.3V/-1.3V	5 -1.3V/-1.3V
6 0V/0V	6 0V/0V	6 0V/0V	6 0V/0V
7 -34V/-40V	7 -34V/-40V	7 -34V/-40V	7 -34V/-40V
8 -34V/-41V	8 -34V/-41V	8 -34V/-41V	8 -34V/-41V
9 -37V/-42V	9 -37V/-42V	9 -37V/-42V	9 -37V/-42V
10 0V/0V	10 0V/0V	10 0V/0V	10 0V/0V
11 37V/42V	11 37V/42V	11 37V/42V	11 37V/42V
12 36V/41V	12 36V/41V	12 36V/41V	12 36V/41V
13 0V/0V	13 0V/0V	13 0V/0V	13 0V/0V
14 37V/42V	14 37V/42V	14 37V/42V	14 37V/42V
15 1.3V/-1.3V	15 1.3V/-1.3V	15 1.3V/-1.3V	15 1.3V/-1.3V
16 0V/0V	16 0V/0V	16 0V/0V	16 0V/0V
17 -1.3V/-0.3V	17 -1.3V/-0.3V	17 -1.3V/-0.3V	17 -1.3V/-0.3V
18 -0.3V/-0.3V	18 -0.3V/-0.3V	18 -0.3V/-0.3V	18 -0.3V/-0.3V
IC751	1 0V/0V	IC701	1 0V/0V
2 0V/0V	2 0V/0V	2 0V/0V	2 0V/0V
3 0V/0V	3 0V/0V	3 0V/0V	3 0V/0V
4 1.8V/2.1V	4 1.8V/2.1V	4 1.8V/2.1V	4 1.8V/2.1V
5 0V/0V	5 0V/0V	5 0V/0V	5 0V/0V
6 0V/0V	6 0V/0V	6 0V/0V	6 0V/0V
7 2.2V/2.1V	7 2.2V/2.1V	7 2.2V/2.1V	7 2.2V/2.1V
8 3.4V/3.2V	8 3.4V/3.2V	8 3.4V/3.2V	8 3.4V/3.2V

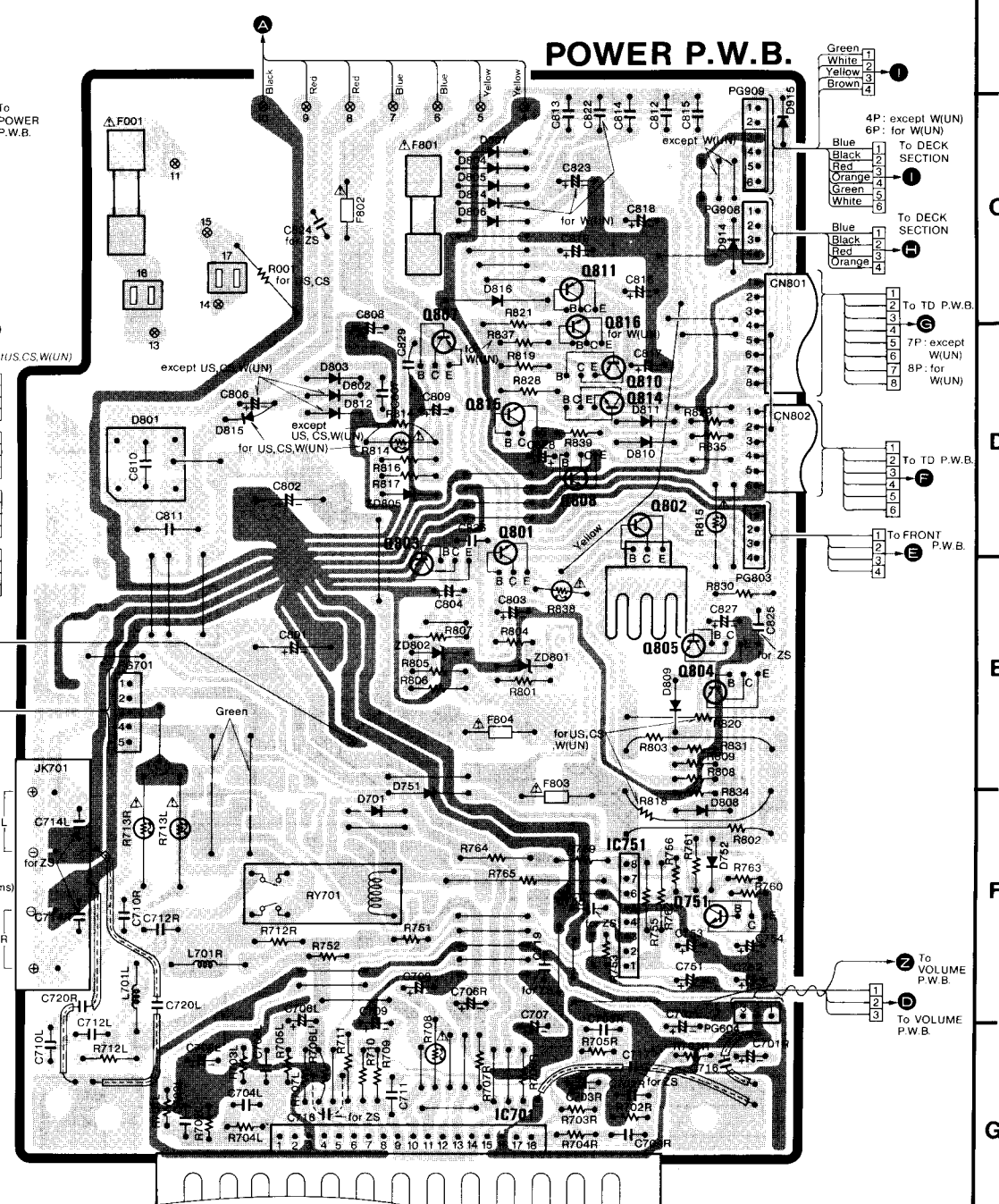

A
B
C
D
E
F
G

BLOCK DIAGRAM • DIAGRAMME SYNOPTIQUE

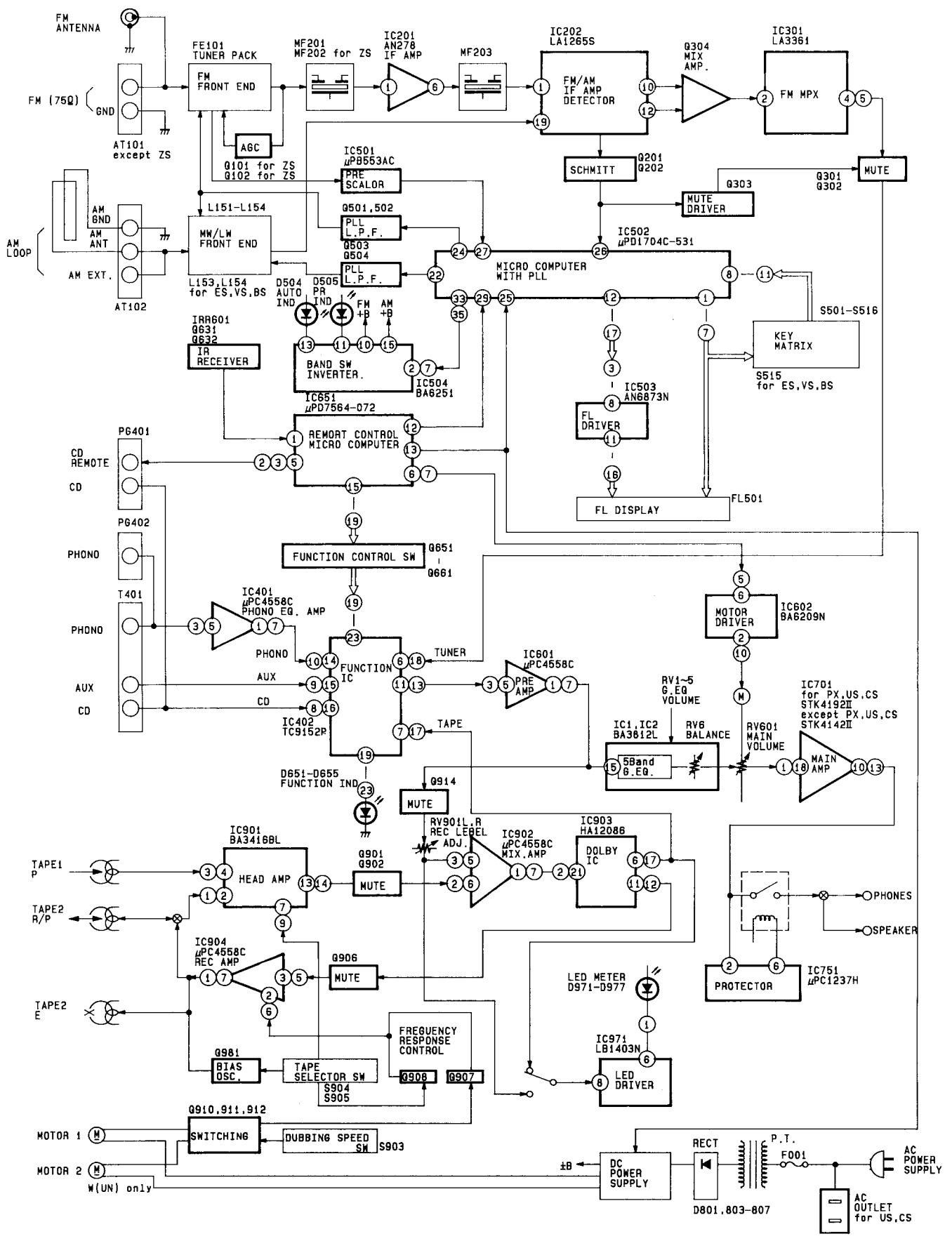

EXPLODED VIEW • VUE ECLATÉE

HRD-MD38/53

• Cabinet section

- Nos. are reference Nos. of parts list.
- Les numéros se réfèrent à la list de pièces

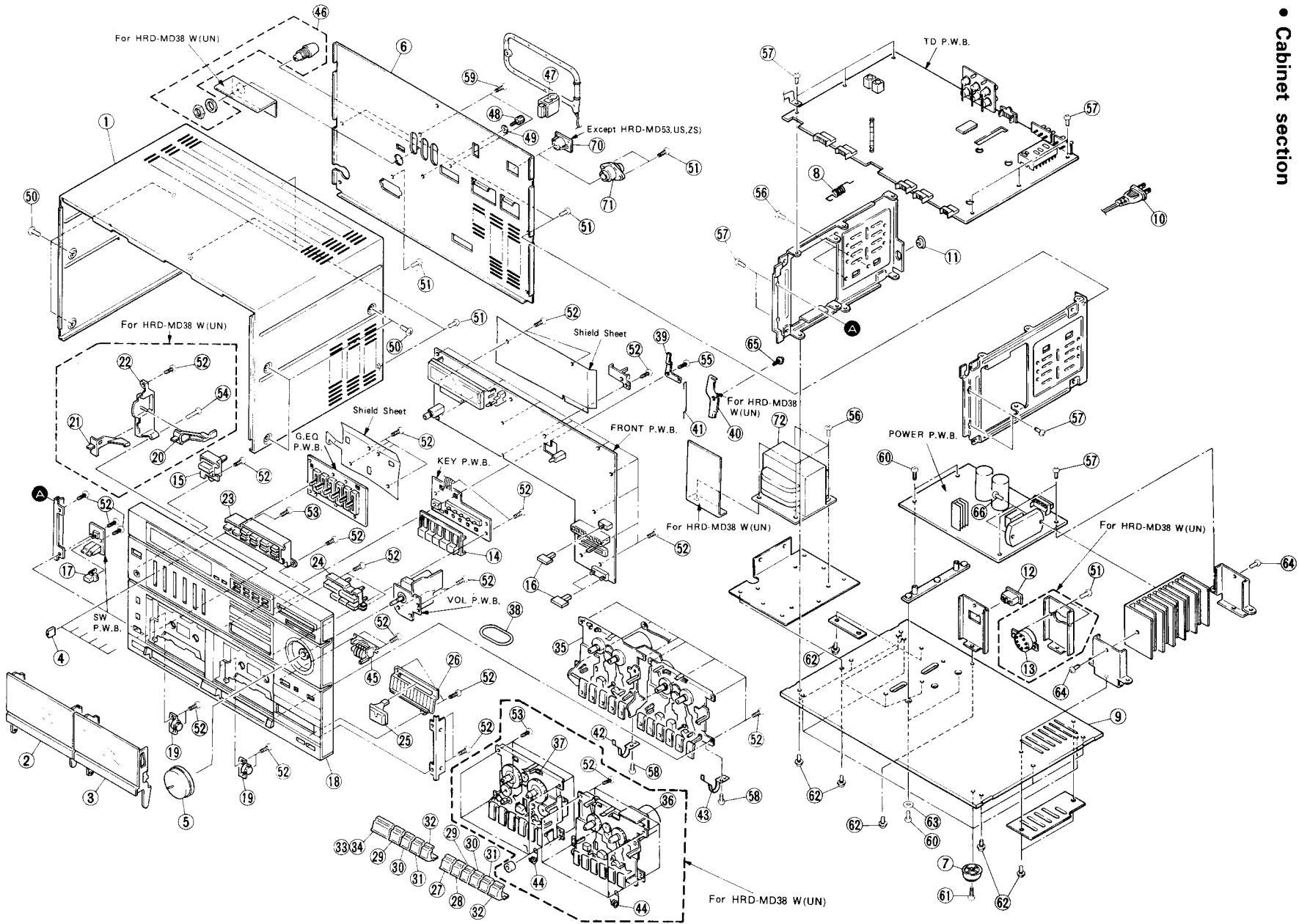

■ Cassette chassis (TN-21SW-985)

● Nos. are reference Nos. of parts list.
● Les numéros se réfèrent à la list de pièces

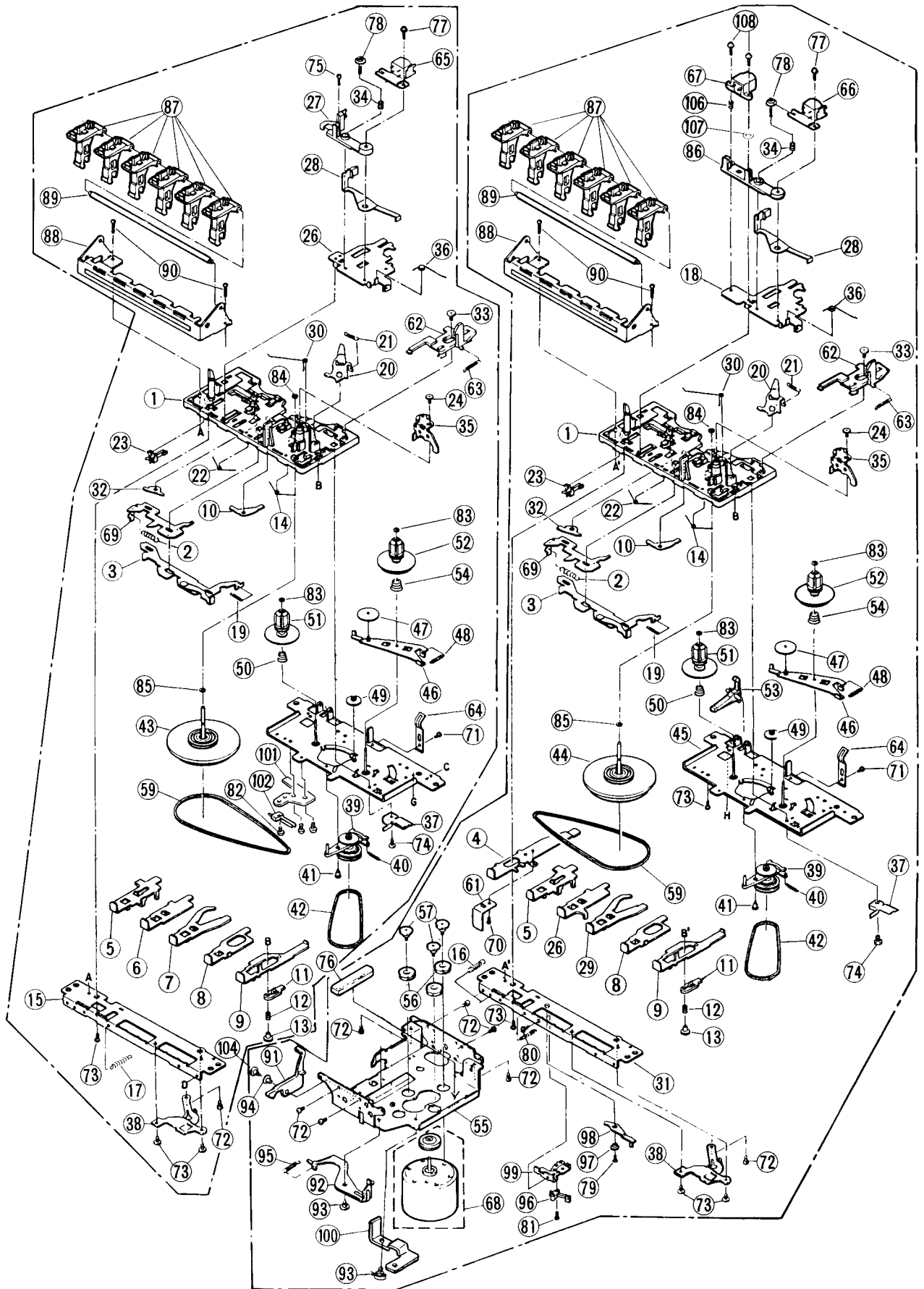

■ Cassette chassis TAPE 1 (TN-222F-147)

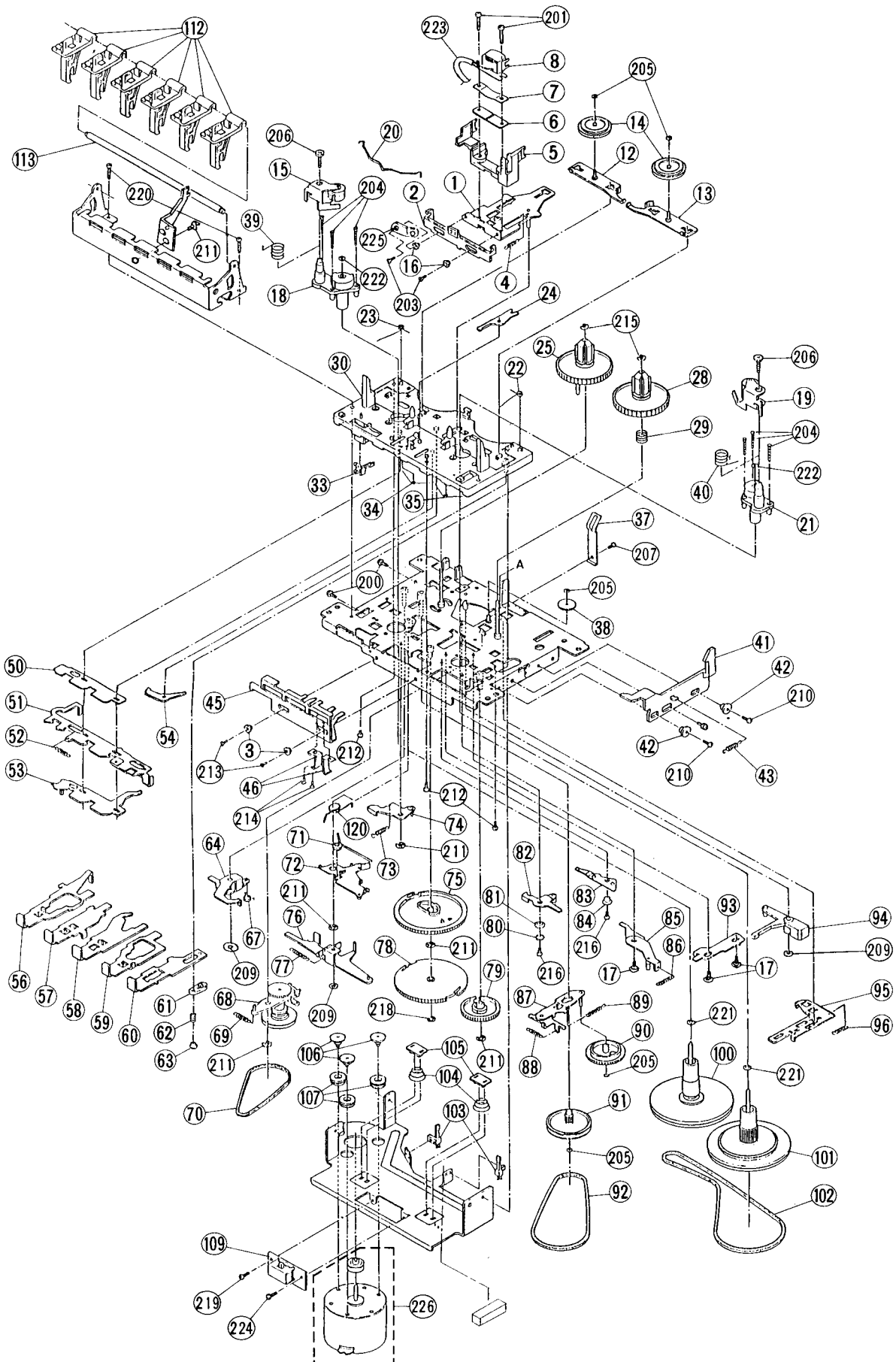

■ Casstee chassis TAPE 2 (TN-29F-210)

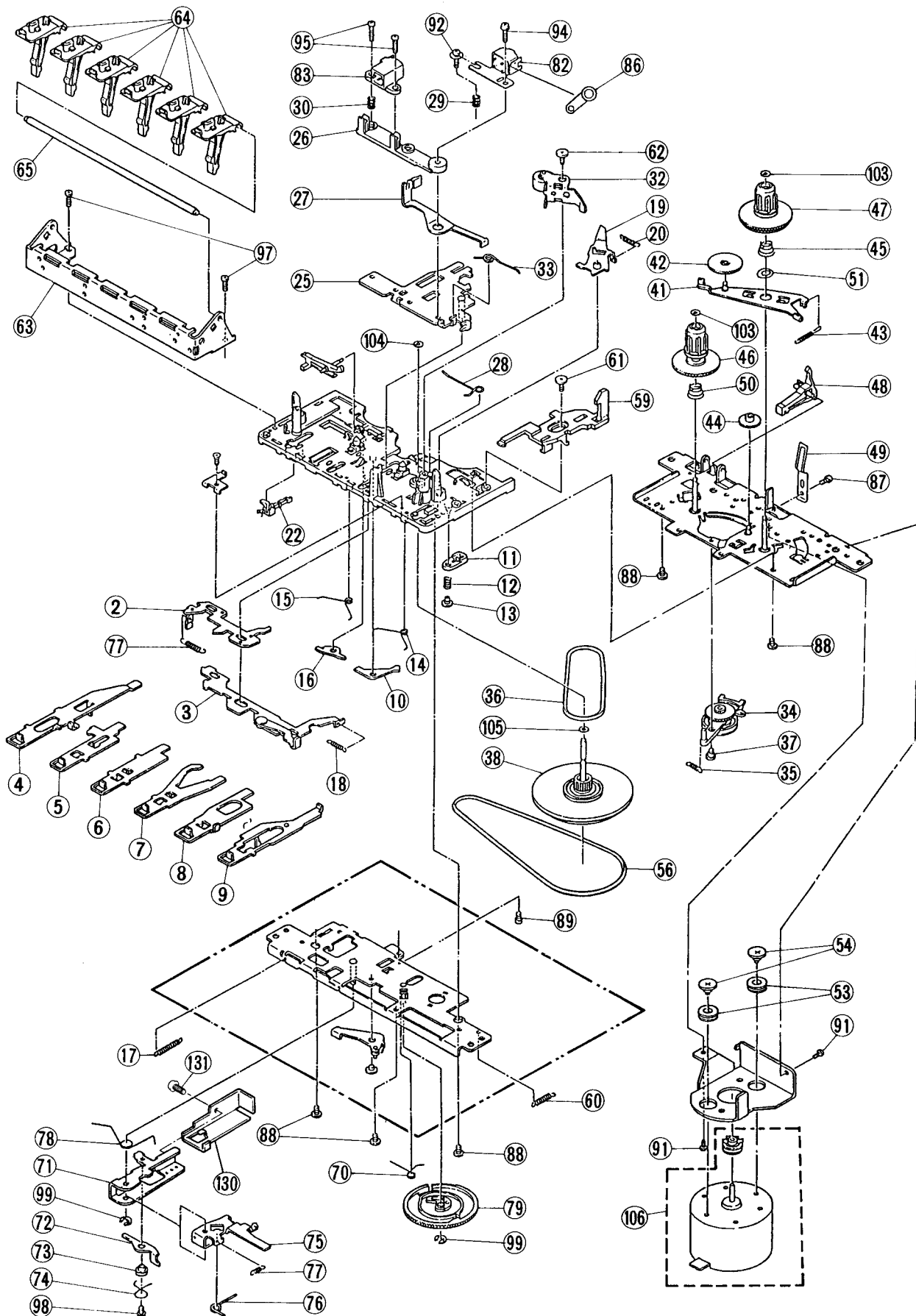

SYMBOL No.	PART No.	DESCRIPTION	SYMBOL No.	PART No.	DESCRIPTION	SYMBOL No.	PART No.	DESCRIPTION
C302	0209731	CD 1000pF ±10% 50V	C510	0246449	CD 24pF ±5% 50V	C720L,R	0244173	CD 0.022μF $\pm\frac{+80\%}{-20\%}$ 50V
C303	0275015	MF 0.047μF ±10% 50V	C511	0246449	CD 24pF ±5% 50V	C751	0252232	EL 220μF 6.3V
C304	0268446	PP 1000pF ±5% 100V	C512	0244173	CD 0.022μF $\pm\frac{+80\%}{-20\%}$ 50V			(for HRD-MD53 US,CS, HRD-MD38 W(UN))
C305	0252805	EL 0.47μF 50V	C513	0252242	EL 2200μF 6.3V	C751	0252231	EL 100μF 6.3V
C306	0252805	EL 0.47μF 50V	C516	0252822	EL 22μF 50V			(except HRD-MD53 US, CS, HRD-MD38 W(UN))
C307	0252811	EL 1μF 50V	C517	0240220	CD 0.047μF ±10% 25V	C752	0252811	EL 1μF 50V
C308	0240212	CD 0.01μF ±10% 50V (for HRD-MD53 CS,US)	C518	0240220	CD 0.047μF ±10% 25V	C753	0252815	EL 4.7μF 50V
C308	0209736	CD 6800pF ±10% 50V (except HRD-MD53 CS,US)	C519	0244173	CD 0.022μF $\pm\frac{+80\%}{-20\%}$ 50V	C754	0252323	EL 33μF 10V
C309	0240212	CD 0.01μF ±10% 50V (for HRD-MD53 CS,US)	C520	0244173	CD 0.022μF $\pm\frac{+80\%}{-20\%}$ 50V (for HRD-MD38 ZS)	C755	0276013	MF 0.22μF ±10% 50V (for HRD-MD38 ZS)
C309	0209736	CD 6800pF ±10% 50V (except HRD-MD53 CS,US)	C521	0252815	EL 4.7μF 50V	C801	0259931	EL 6800μF 50V (for HRD-MD53 CS,US, HRD-MD38 W(UN))
C310	0209733	CD 2200pF ±10% 50V	C523	0252631	EL 100μF 25V	C801	0255001	EL 4700μF 40V (except HRD-MD53 CS, US, HRD-MD38 W(UN))
C311	0209733	CD 2200pF ±10% 50V	C524	0252322	EL 22μF 10V	C802	0259931	EL 6800μF 50V (for HRD-MD53 CS,US, HRD-MD38 W(UN))
C312	0252813	EL 3.3μF 50V	C601L,R	0252811	EL 1μF 50V	C802	0255001	EL 4700μF 40V (except HRD-MD53 CS, US, HRD-MD38 W(UN))
C313	0252813	EL 3.3μF 50V	C602L,R	0252813	EL 3.3μF 50V	C802	0255001	EL 4700μF 40V (except HRD-MD53 CS, US, HRD-MD38 W(UN))
C314	0252522	EL 22μF 16V	C603	0252521	EL 10μF 16V	C803	0252625	EL 47μF 25V
C315	0252813	EL 3.3μF 50V (for HRD-MD38 ZS)	C604	0252521	EL 10μF 16V	C804	0252625	EL 47μF 25V
C316	0252813	EL 3.3μF 50V	C605L,R	0208688	CD 150pF ±5% 50V	C806	0252465	EL 33μF ±5% 50V (except HRD-MD53 CS, US, HRD-MD38 W(UN))
C317	0252813	EL 3.3μF 50V	C606L,R	0240244	CD 0.015μF ±10% 50V	C807	0244173	CD 0.022μF $\pm\frac{+80\%}{-20\%}$ 50V
C318	0252811	EL 1μF 50V	C607L,R	0209723	CD 470pF ±10% 50V	C808	1252831	EL 100μF 50V (for HRD-MD53 CS,US, HRD-MD38 W(UN))
C319	0252811	EL 1μF 50V	C608	0240220	CD 0.047μF ±10% 25V	C808	0255021	EL 100μF 100V (except HRD-MD53 CS, US, HRD-MD38 W(UN))
C320	0209724	CD 560pF ±10% 50V (for HRD-MD38 ZS)	C609	0244171	CD 0.01μF $\pm\frac{+80\%}{-20\%}$ 50V	C809	0252825	EL 47μF 50V
C401L,R	0208696	CD 330pF ±5% 50V (for HRD-MD38 ZS)	C611	0244173	CD 0.022μF $\pm\frac{+80\%}{-20\%}$ 50V	C810	0245408	CD 0.01μF 500V
C401L,R	0208688	CD 150pF ±5% 50V (except HRD-MD38 ZS)	C612	0252535	EL 470μF 16V	C811	0245408	CD 0.01μF 500V
C402L,R	0252811	EL 1μF 50V	C613	0276011	MF 0.1μF ±10% 50V	C812	0244173	CD 0.022μF $\pm\frac{+80\%}{-20\%}$ 50V
C403L,R	0252225	EL 47μF 6.3V	C614	0209731	CD 1000pF ±10% 50V	C813	0244173	CD 0.022μF $\pm\frac{+80\%}{-20\%}$ 50V
C404	0252521	EL 10μF 16V	C615	0209731	CD 1000pF ±10% 50V	C814	0244173	CD 0.022μF $\pm\frac{+80\%}{-20\%}$ 50V
C405	0252521	EL 10μF 16V	C631	0275013	MF 0.022μF ±10% 50V	C815	0244173	CD 0.022μF $\pm\frac{+80\%}{-20\%}$ 50V
C406L,R	0208694	CD 270pF ±5% 50V	C632	0252225	EL 47μF 6.3V	C816	0252535	EL 470μF 16V
C407L,R	0274036	MF 8200pF ±10% 50V	C651	0246464	CD 100pF ±5% 50V	C817	0252541	EL 1000μF 16V
C408L,R	0209733	CD 2200pF ±10% 50V	C652	0246464	CD 100pF ±5% 50V	C818	0252535	EL 470μF 16V
C409L,R	0252812	EL 2.2μF 50V	C653	0252231	EL 100μF 6.3V	C819	0252541	EL 1000μF 16V
C411L,R	0208684	CD 100pF ±5% 50V (for HRD-MD38 ZS)	C654	0252231	EL 100μF 6.3V	C822	0244173	CD 0.022μF $\pm\frac{+80\%}{-20\%}$ 50V (for HRD-MD38 W(UN))
C412L,R	0208684	CD 100pF ±5% 50V (for HRD-MD38 ZS)	C655	0252521	EL 10μF 16V	C823	0252541	EL 1000μF 16V (for HRD-MD38 W(UN))
C414	0244173	CD 0.022μF $\pm\frac{+80\%}{-20\%}$ 50V	C656	0209724	CD 560pF ±10% 50V	C824	0276511	MF 0.1μF ±10% 100V (for HRD-MD38 ZS)
C415	0252811	EL 1μF 50V	C701L,R	0252813	EL 3.3μF 50V	C825	0276013	MF 0.22μF ±10% 50V (for HRD-MD38 ZS)
C416	0244173	CD 0.022μF $\pm\frac{+80\%}{-20\%}$ 50V	C702L,R	0209726	CD 820pF ±10% 50V (for HRD-MD38 ZS)	C826	0276013	MF 0.22μF ±10% 50V (for HRD-MD38 ZS)
C417	0244173	CD 0.022μF $\pm\frac{+80\%}{-20\%}$ 50V (for HRD-MD38 ZS)	C702L,R	0209723	CD 470pF ±10% 50V (except HRD-MD38 ZS)	C827	0252521	EL 10μF 16V
C418	0252812	EL 2.2μF 50V	C703L,R	0252231	EL 100μF 6.3V	C828	0252521	EL 10μF 16V
C419	0275036	MF 0.082μF ±10% 50V	C704L,R	0209731	CD 1000pF ±10% 50V (for HRD-MD38 ZS)	C829	0209731	CD 1000pF ±10% 50V
C501	0209733	CD 2200pF ±10% 50V	C704L,R	0208696	CD 330pF ±5% 50V (except HRD-MD38 ZS)	C901L,R	0209721	CD 330pF ±10% 50V
C502	0252880	EL 4.7μF 50V	C705L,R	0248641	CD 1pF ±0.5% 50V (for HRD-MD38 ZS)	C902L,R	0209721	CD 330pF ±10% 50V
C503	0244173	CD 0.022μF $\pm\frac{+80\%}{-20\%}$ 50V	C705L,R	0248633	CD 3pF ±0.25% 50V (except HRD-MD38 ZS)	C904L,R	0209721	CD 330pF ±10% 50V
C504	0252802	EL 0.22μF 50V (for HRD-MD38 ES,VS,BK)	C706L,R	0252825	EL 47μF 50V	C905L,R	0252231	EL 100μF 6.3V
C505	0252811	EL 1μF 50V (for HRD-MD38 ES,VS,BK)	C707	0252821	EL 10μF 50V	C906L,R	0240218	CD 0.033μF ±10% 25V
C506	0240222	CD 0.068μF ±10% 25V (for HRD-MD38 ES,VS,BK)	C708	0257189	EL 100μF B.P. 50V	C907	0252522	EL 22μF 16V
C507	0244173	CD 0.022μF $\pm\frac{+80\%}{-20\%}$ 50V	C709	0252821	EL 10μF 50V	C908	0252522	EL 22μF 16V
C508	0252531	EL 100μF 6.3V	C710L,R	0276011	MF 0.1μF ±10% 50V			
C509	0244171	CD 0.01μF $\pm\frac{+80\%}{-20\%}$ 50V	C711	0276511	MF 0.1μF ±10% 100V			
			C712L,R	0276011	MF 0.1μF ±10% 50V			
			C714L,R	0244173	CD 0.022μF $\pm\frac{+80\%}{-20\%}$ 50V (for HRD-MD38 ZS)			
			C715L,R	0244171	CD 0.01μF $\pm\frac{+80\%}{-20\%}$ 50V (for HRD-MD38 ZS)			
			C716	0244173	CD 0.022μF $\pm\frac{+80\%}{-20\%}$ 50V			
			C717	0244173	CD 0.022μF $\pm\frac{+80\%}{-20\%}$ 50V (for HRD-MD38 ZS)			
			C718	0244173	CD 0.022μF $\pm\frac{+80\%}{-20\%}$ 50V (for HRD-MD38 ZS)			
			C719	0244173	CD 0.022μF $\pm\frac{+80\%}{-20\%}$ 50V (for HRD-MD38 ZS)			

HT-MD28

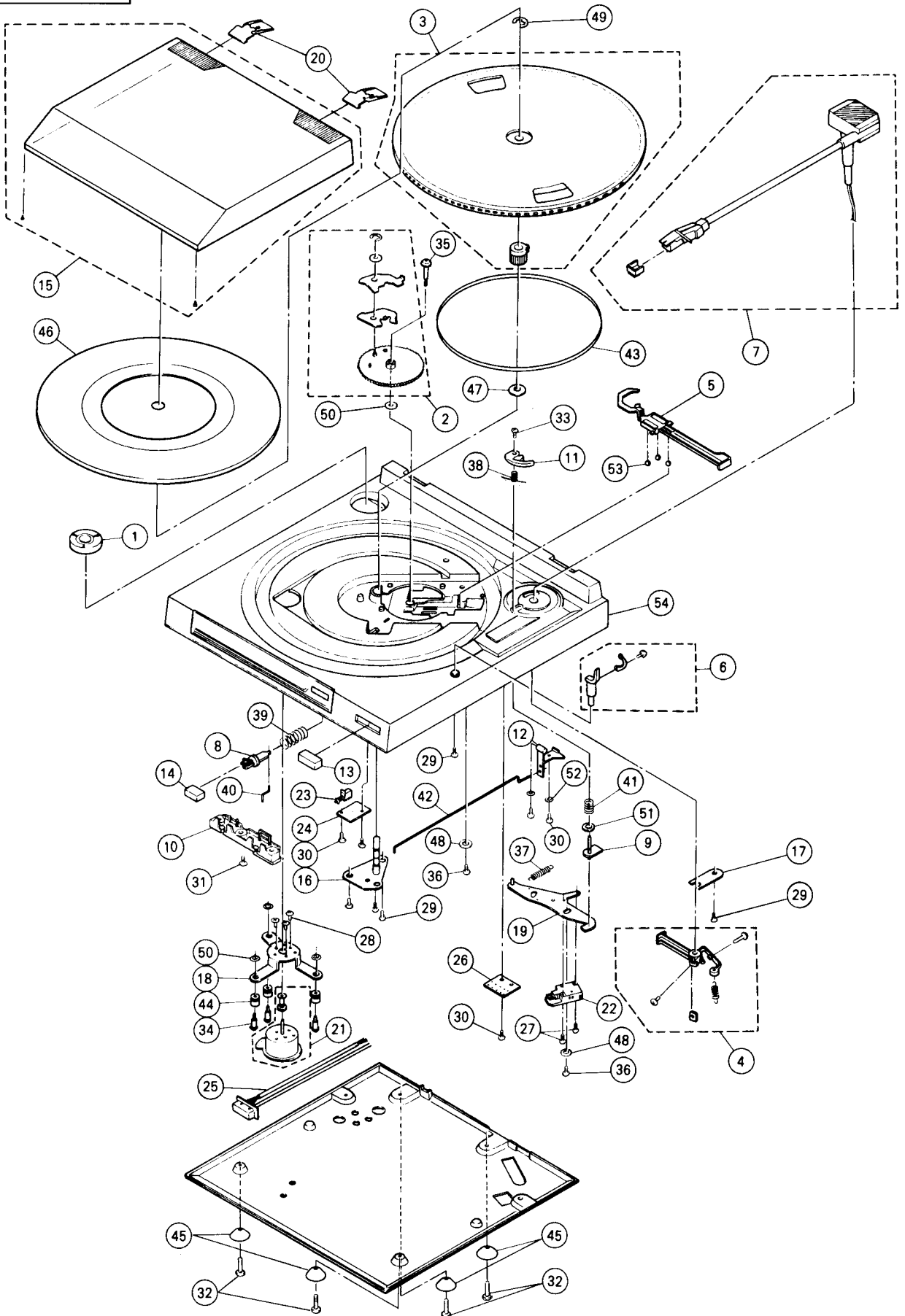

■ Speaker (HS-MD38)

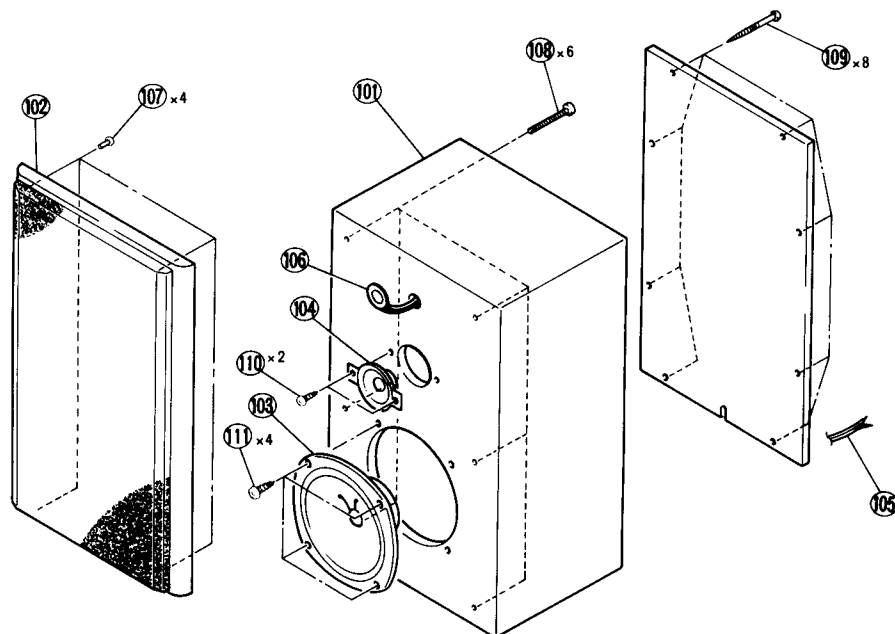

REPLACEMENT PARTS LIST • LISTE DES PIÈCES DE RECHANGE

CD.....Ceramic disc EL..... Electrolytic ST..... Styrol ME..... Metal CO..... Composition
 CC..... Cylindrical ceramic MF..... Mylar, film CF..... Carbon film MO..... Metal, oxide FR..... Fuse resistor

SYMBOL No.	PART No.	DESCRIPTION	SYMBOL No.	PART No.	DESCRIPTION	SYMBOL No.	PART No.	DESCRIPTION
CAPACITORS								
C1	0252813	EL 3.3 μ F 50V	C102	0252802	EL 0.22 μ F 50V (for HRD-MD38 ZS)	C159	0244173	CD 0.022 μ F $\begin{smallmatrix} +80\% \\ -20\% \end{smallmatrix}$ 50V (for HRD-MD38 ES, VS, BK)
C2	0252813	EL 3.3 μ F 50V	C103	0244173	CD 0.022 μ F 50V (for HRD-MD38 ZS)	C160	0244173	CD 0.022 μ F $\begin{smallmatrix} +80\% \\ -20\% \end{smallmatrix}$ 50V
C3	0252813	EL 3.3 μ F 50V	C104	0252811	EL 1 μ F 50V (for HRD-MD38 ZS)	C161	0252811	EL 1 μ F 50V (for HRD-MD38 ES, VS, BK)
C4	0252813	EL 3.3 μ F 50V	C105	0208674	CD 39pF \pm 5% 50V (for HRD-MD38 ZS)	C162	0252521	EL 10 μ F 16V
C5	0252801	EL 0.1 μ F 50V	C106	0208674	CD 39pF \pm 5% 50V (for HRD-MD38 ZS)	C201	0244173	CD 0.022 μ F $\begin{smallmatrix} +80\% \\ -20\% \end{smallmatrix}$ 50V
C6	0252801	EL 0.1 μ F 50V	C107	0244173	CD 0.022 μ F 50V	C202	0244173	CD 0.022 μ F $\begin{smallmatrix} +80\% \\ -20\% \end{smallmatrix}$ 50V
C7	0252805	EL 0.47 μ F 50V	C108	0248635	CD 5pF \pm 0.25% 50V (for HRD-MD38 ZS)	C203	0244173	CD 0.022 μ F $\begin{smallmatrix} +80\% \\ -20\% \end{smallmatrix}$ 50V
C8	0252805	EL 0.47 μ F 50V	C109	0244173	CD 0.022 μ F 50V (except HRD-MD38 ZS)	C204	0244171	CD 0.01 μ F $\begin{smallmatrix} +80\% \\ -20\% \end{smallmatrix}$ 50V
C9	0275013	MF 0.022 μ F \pm 10% 50V	C151	0246428	CD 8pF \pm 0.5% 50V (for HRD-MD38 ES, VS, BK)	C205	0240220	CD 0.047 μ F \pm 10% 25V
C10	0275013	MF 0.022 μ F \pm 10% 50V	C151	0246412	CD 2pF \pm 0.15% 50V (except BS, ES, VS)	C206	0244171	CD 0.01 μ F $\begin{smallmatrix} +80\% \\ -20\% \end{smallmatrix}$ 50V
C11	0252803	EL 0.33 μ F 50V	C152	0279326	PP 510pF \pm 2% 100V	C207	0240220	CD 0.047 μ F \pm 10% 25V
C12	0252803	EL 0.33 μ F 50V	C153	0246442	CD 12pF \pm 5% 50V	C208	0252811	EL 1 μ F 50V
C13	0274015	MF 4700pF \pm 10% 50V	C154	0246454	CD 39pF \pm 5% 50V (for HRD-MD38 ES, VS, BK)	C209	0252813	EL 3.3 μ F 50V
C14	0274015	MF 4700pF \pm 10% 50V	C155	0244173	CD 0.022 μ F $\begin{smallmatrix} +80\% \\ -20\% \end{smallmatrix}$ 50V	C210	0208684	CD 100pF \pm 5% 50V
C15	0275016	MF 0.068 μ F \pm 10% 50V	C156	0244173	CD 0.022 μ F $\begin{smallmatrix} +80\% \\ -20\% \end{smallmatrix}$ 50V (for HRD-MD38 ES, VS, BK)	C211	0252521	EL 10 μ F 16V
C16	0275016	MF 0.068 μ F \pm 10% 50V	C157	0228321	ST 270pF \pm 5% 50V (for HRD-MD38 ES, VS, BK)	C212	0252521	EL 10 μ F 16V
C17	0249731	CD 1000pF \pm 10% 50V	C158	0246465	CD 110pF \pm 5% 50V (for HRD-MD38 ES, VS, BK)	C213	0252525	EL 47 μ F 16V
C18	0249731	CD 1000pF \pm 10% 50V				C214	0244171	CD 0.01 μ F $\begin{smallmatrix} +80\% \\ -20\% \end{smallmatrix}$ 50V
C19	0275013	MF 0.022 μ F \pm 10% 50V				C215	0244173	CD 0.022 μ F $\begin{smallmatrix} +80\% \\ -20\% \end{smallmatrix}$ 50V
C20	0275013	MF 0.022 μ F \pm 10% 50V				C216	0252815	EL 4.7 μ F 50V
C21	0248696	CD 330pF \pm 5% 50V				C217	0252813	EL 3.3 μ F 50V
C22	0248696	CD 330pF \pm 5% 50V				C218	0252521	EL 10 μ F 16V
C23	0274015	MF 4700pF \pm 10% 50V				C219	0209731	CD 1000pF \pm 10% 50V
C24	0274015	MF 4700pF \pm 10% 50V				C220	0244171	CD 0.01 μ F $\begin{smallmatrix} +80\% \\ -20\% \end{smallmatrix}$ 50V
C25	0249731	CD 1000pF \pm 10% 50V				C221	0244171	CD 0.01 μ F $\begin{smallmatrix} +80\% \\ -20\% \end{smallmatrix}$ 50V
C26	0249731	CD 1000pF \pm 10% 50V				C222	0240220	CD 0.047 μ F \pm 10% 25V
C27	0252813	EL 3.3 μ F 50V				C223	0244173	CD 0.022 μ F $\begin{smallmatrix} +80\% \\ -20\% \end{smallmatrix}$ 50V
C28	0252813	EL 3.3 μ F 50V				C224	0252521	EL 10 μ F 16V
C29	0249731	CD 1000pF \pm 10% 50V				C225	0246456	CD 47pF \pm 5% 50V
C30	0249731	CD 1000pF \pm 10% 50V				C226	0240220	CD 0.047 μ F \pm 10% 25V
C31	0252525	EL 47 μ F 16V				C301	0252525	EL 47 μ F 16V
C101	0275015	MF 0.047 μ F \pm 10% 50V						

SYMBOL No.	PART No.	DESCRIPTION	SYMBOL No.	PART No.	DESCRIPTION	SYMBOL No.	PART No.	DESCRIPTION
C909	0252525	EL 47 μ F 16V	RESISTOR			R209	0113639	CF 10k Ω \pm 5% SRD1/6P
C910L,R	0244173	CD 0.022 μ F $\begin{smallmatrix} +80\% \\ -20\% \end{smallmatrix}$ 50V (except HRD-MD38 W(UN))	R1	0113615	CF 1k Ω \pm 5% SRD1/6P	R210	0113655	CF 47k Ω \pm 5% SRD1/6P
C910L,R	0240218	CD 0.033 μ F \pm 10% 25V (for HRD-MD38 W(UN))	R2	0113615	CF 1k Ω \pm 5% SRD1/6P	R211	0113649	CF 27k Ω \pm 5% SRD1/6P
C911L,R	0252813	EL 3.3 μ F 50V	R3	0113655	CF 47k Ω \pm 5% SRD1/6P	R212	0113663	CF 100k Ω \pm 5% SRD1/6P
C912L,R	0209731	CD 1000pF \pm 10% 50V (except HRD-MD38 W(UN))	R4	0113655	CF 47k Ω \pm 5% SRD1/6P	R213	0113591	CF 100 Ω \pm 5% SRD1/6P
C913L,R	0252813	EL 3.3 μ F 50V	R5	0113663	CF 100k Ω \pm 5% SRD1/6P	R214	0113639	CF 10k Ω \pm 5% SRD1/6P
C914	0244173	CD 0.022 μ F $\begin{smallmatrix} +80\% \\ -20\% \end{smallmatrix}$ 50V	R6	0113663	CF 100k Ω \pm 5% SRD1/6P	R215	0113641	CF 12k Ω \pm 5% SRD1/6P (for HRD-MD53 CS,US)
C915	0244173	CD 0.022 μ F $\begin{smallmatrix} +80\% \\ -20\% \end{smallmatrix}$ 50V	R7	0113631	CF 4.7k Ω \pm 5% SRD1/6P	R215	0113649	CF 27k Ω \pm 5% SRD1/6P (except HRD-MD53 CS,US)
C916L,R	0209731	CD 1000pF \pm 10% 50V	R8	0113631	CF 4.7k Ω \pm 5% SRD1/6P	R216	0113645	CF 18k Ω \pm 5% SRD1/6P
C917L,R	0209733	CD 2200pF \pm 10% 50V	R9	0113631	CF 4.7k Ω \pm 5% SRD1/6P	R217	0113659	CF 68k Ω \pm 5% SRD1/6P
C918L,R	0252813	EL 3.3 μ F 50V	R10	0113631	CF 4.7k Ω \pm 5% SRD1/6P	R218	0113641	CF 12k Ω \pm 5% SRD1/6P
C919	0252813	EL 3.3 μ F 50V	R11	0113631	CF 4.7k Ω \pm 5% SRD1/6P	R219	0113601	CF 270 Ω \pm 5% SRD1/6P
C920L,R	0252813	EL 3.3 μ F 50V	R12	0113631	CF 4.7k Ω \pm 5% SRD1/6P	R220	0113639	CF 10k Ω \pm 5% SRD1/6P
C921L,R	0244171	CD 0.01 μ F $\begin{smallmatrix} +80\% \\ -20\% \end{smallmatrix}$ 50V	R001	0139005	CO 2.7M Ω \pm 10% RC1/2GF (for HRD-MD53 CS,US)	R221	0113635	CF 6.8k Ω \pm 5% SRD1/6P (except HRD-MD38 ZS)
C922L,R	0240244	CD 0.015 μ F \pm 10% 50V	R101	0113625	CF 2.7k Ω \pm 5% SRD1/6P	R221	0113637	CF 8.2k Ω \pm 5% SRD1/6P (for HRD-MD38 ZS)
C923L,R	0252807	EL 0.68 μ F 50V	R102	0113663	CF 100k Ω \pm 5% SRD1/6P	R222	0113639	CF 10k Ω \pm 5% SRD1/6P
C924L,R	0252812	EL 2.2 μ F 50V	R103	0113663	CF 100k Ω \pm 5% SRD1/6P (for HRD-MD38 ZS)	R223	0113591	CF 100 Ω \pm 5% SRD1/6P
C925L,R	0252813	EL 3.3 μ F 50V	R104	0113591	CF 100 Ω \pm 5% SRD1/6P (for HRD-MD38 ZS)	R224	0113627	CF 3.3k Ω \pm 5% SRD1/6P
C926	0252232	EL 220 μ F 6.3V	R105	0113639	CF 10k Ω \pm 5% SRD1/6P (for HRD-MD38 ZS)	R225	0113647	CF 22k Ω \pm 5% SRD1/6P
C927	0252531	EL 100 μ F 16V	R106	0113617	CF 1.2k Ω \pm 5% SRD1/6P (for HRD-MD38 ZS)	R226	0113663	CF 100k Ω \pm 5% SRD1/6P
C928	0209731	CD 1000pF \pm 10% 50V	R107	0113663	CF 100k Ω \pm 5% SRD1/6P (for HRD-MD38 ZS)	R227	0113663	CF 100k Ω \pm 5% SRD1/6P
C929L,R	0209721	CD 330pF \pm 10% 50V	R108	1123623	NFR 150 Ω \pm 5% RN1/4B (except HRD-MD38 ZS)	R228	0113639	CF 10k Ω \pm 5% SRD1/6P
C930L,R	0252803	EL 0.33 μ F 50V	R108	1123619	NFR 68 Ω \pm 5% RN1/4B (for HRD-MD38 ZS)	R229	1119425	MO220 Ω \pm 10% RS1B
C931L,R	0208688	CD 150pF \pm 5% 50V	R109	0113599	CF 220 Ω \pm 5% SRD1/6P (for HRD-MD38 ZS)	R230	0113623	CF 2.2k Ω \pm 5% SRD1/6P
C932L,R	0274016	MF 6800pF \pm 10% 50V	R110	0113599	CF 220 Ω \pm 5% SRD1/6P (except HRD-MD38 ZS)	R301	1123632	NFR 820 Ω \pm 5% RN1/4B
C933L,R	0240215	CD 0.018 μ F \pm 10% 25V	R151	0113639	CF 10k Ω \pm 5% SRD1/6P	R302	0113635	CF 6.8k Ω \pm 5% SRD1/6P
C934L,R	0240218	CD 0.033 μ F \pm 10% 25V (except HRD-MD38 W(UN))	R152	0113639	CF 10k Ω \pm 5% SRD1/6P (for HRD-MD38 ES,VS,BK)	R303	0113615	CF 1k Ω \pm 5% SRD1/6P
C934L,R	1240220	CD 0.047 μ F \pm 10% 25V (for HRD-MD38 W(UN))	R153	0113639	CF 10k Ω \pm 5% SRD1/6P (for HRD-MD38 ES,VS,BK)	R304	0113633	CF 5.6k Ω \pm 5% SRD1/6P
C936L,R	0252813	EL 3.3 μ F 50V	R154	0113671	CF 220k Ω \pm 5% SRD1/6P	R305	0113633	CF 5.6k Ω \pm 5% SRD1/6P
C937	0244173	CD 0.022 μ F $\begin{smallmatrix} +80\% \\ -20\% \end{smallmatrix}$ 50V	R155	0113663	CF 100k Ω \pm 5% SRD1/6P (for HRD-MD38 ES,VS,BK)	R306	0113631	CF 4.7k Ω \pm 5% SRD1/6P
C938	0244173	CD 0.022 μ F $\begin{smallmatrix} +80\% \\ -20\% \end{smallmatrix}$ 50V	R156	0113623	CF 2.2k Ω \pm 5% SRD1/6P (for HRD-MD38 ES,VS,BK)	R307	0113631	CF 4.7k Ω \pm 5% SRD1/6P
C939L,R	0209733	CD 2200pF \pm 10% 50V	R157	0113671	CF 220k Ω \pm 5% SRD1/6P (for HRD-MD38 ES,VS,BK)	R308	0113605	CF 390 Ω \pm 5% SRD1/6P (except HRD-MD38 ZS)
C940	0252522	EL 22 μ F 16V	R158	0113631	CF 4.7k Ω \pm 5% SRD1/6P (for HRD-MD38 ES,VS,BK)	R308	0113615	CF 1k Ω \pm 5% SRD1/6P (for HRD-MD38 ZS)
C941	0252813	EL 3.3 μ F 50V (except HRD-MD38 W(UN))	R159	0113365	CF 1k Ω \pm 5% SRD1/2P	R309	0113663	CF 100k Ω \pm 5% SRD1/6P
C941	0252232	EL 220 μ F 6.3V (for HRD-MD38 W(UN))	R202	0113603	CF 330 Ω \pm 5% SRD1/6P	R311	0113663	CF 100k Ω \pm 5% SRD1/6P
C942	0244171	CD 0.01 μ F $\begin{smallmatrix} +80\% \\ -20\% \end{smallmatrix}$ 50V (for HRD-MD38 ZS)	R203	0113615	CF 1k Ω \pm 5% SRD1/6P (for HRD-MD38 ZS)	R312	0113623	CF 2.2k Ω \pm 5% SRD1/6P
C943L,R	0252813	EL 3.3 μ F 50V	R203	0113623	CF 2.2k Ω \pm 5% SRD1/6P (except HRD-MD38 ZS)	R313	0113663	CF 100k Ω \pm 5% SRD1/6P
C945	0252815	EL 4.7 μ F 50V	R204	0113605	CF 390 Ω \pm 5% SRD1/6P	R315	0113655	CF 47k Ω \pm 5% SRD1/6P (for HRD-MD38 ZS)
C946L,R	0209735	CD 4700pF \pm 10% 50V	R205	0113619	CF 1.5k Ω \pm 5% SRD1/6P	R316	0113665	CF 120k Ω \pm 5% SRD1/6P
C947	1240220	CD 0.047 μ F \pm 10% 25V	R206	0113639	CF 10k Ω \pm 5% SRD1/6P	R317	0113631	CF 4.7k Ω \pm 5% SRD1/6P
C948	1244173	CD 0.022 μ F $\begin{smallmatrix} +80\% \\ -20\% \end{smallmatrix}$ 50V (except HRD-MD38 W(UN))	R207	0113639	CF 10k Ω \pm 5% SRD1/6P	R318	0113651	CF 33k Ω \pm 5% SRD1/6P
C971	0252521	EL 10 μ F 16V	R208	0113647	CF 22k Ω \pm 5% SRD1/6P	R319	0113623	CF 2.2k Ω \pm 5% SRD1/6P (except HRD-MD38 ZS)
C981	0252525	EL 47 μ F 16V	R209	0113663	CF 100k Ω \pm 5% SRD1/6P	R319	0113617	CF 1.2k Ω \pm 5% SRD1/6P (for HRD-MD38 ZS)
C982	0274016	MF 6800pF \pm 10% 50V	R209	0113639	CF 10k Ω \pm 5% SRD1/6P	R320	0113639	CF 10k Ω \pm 5% SRD1/6P
C983	0275012	MF 0.015 μ F \pm 10% 50V	R209	0113639	CF 10k Ω \pm 5% SRD1/6P	R321	0113639	CF 10k Ω \pm 5% SRD1/6P
C984	0279321	PP 0.015 μ F \pm 5% 100V	R209	0113639	CF 10k Ω \pm 5% SRD1/6P	R322	0113613	CF 820 Ω \pm 5% SRD1/6P (for HRD-MD38 ZS)
C985L,R	0208692	CD 220pF \pm 5% 50V	R209	0113639	CF 10k Ω \pm 5% SRD1/6P	R322	0113623	CF 2.2k Ω \pm 5% SRD1/6P (except HRD-MD38 ZS)
C986	0209732	CD 1500pF \pm 10% 50V (for HRD-MD38 ES,VS,BK)	R209	0113639	CF 10k Ω \pm 5% SRD1/6P	R323	0113663	CF 100k Ω \pm 5% SRD1/6P
C988	0248692	CD 220pF \pm 5% 50V	R209	0113639	CF 10k Ω \pm 5% SRD1/6P	R324	0113663	CF 100k Ω \pm 5% SRD1/6P
C989	0276012	MF 0.15 μ F \pm 10% 50V	R209	0113639	CF 10k Ω \pm 5% SRD1/6P	R401L,R	0113627	CF 3.3k Ω \pm 5% SRD1/6P (for HRD-MD38 ZS)
C990	0276012	MF 0.15 μ F \pm 10% 50V	R209	0113639	CF 10k Ω \pm 5% SRD1/6P	R401L,R	0113623	CF 2.2k Ω \pm 5% SRD1/6P (except HRD-MD38 ZS)
			R209	0113639	CF 10k Ω \pm 5% SRD1/6P	R402L,R	0113655	CF 47k Ω \pm 5% SRD1/6P
			R209	0113639	CF 10k Ω \pm 5% SRD1/6P	R403L,R	0113611	CF 680 Ω \pm 5% SRD1/6P

SYMBOL No.	PART No.	DESCRIPTION	SYMBOL No.	PART No.	DESCRIPTION	SYMBOL No.	PART No.	DESCRIPTION
IC971	2387051	LB1403N	Q905L,R	2328286	2SC458LG(D)	D701	2337151	1S2076A
Q101	2328286	2SC458LG(D) (for HRD-MD38 ZS)	Q906L,R	2328286	2SC458LG(D)	D751	2339002	DS135D
Q102	2328803	2SK104(H) (for HRD-MD38 ZS)	Q907L,R	2328286	2SC458LG(D)	D752	2337601	1S2473
Q151	2328286	2SC458LG(D) (for HRD-MD38 ES,VS,BK)	Q908L,R	2328286	2SC458LG(D)	D801	2337461	S4VB20
Q152	2328286	2SC458LG(D) (for HRD-MD38 ES,VS,BK)	Q909	2328286	2SC458LG(D)	D802	2339001	DS135D(except HRD-MD53 CS,US, HRD-MD38 W(UN))
Q201	2328286	2SC458LG(D)	Q910	2328286	2SC458LG(D)	D803	2339001	DS135D
Q202	2328286	2SC458LG(D)	Q911	2328286	2SC458LG(D)	D804	2339002	DS135D
Q203	2328286	2SC458LG(D)	Q912	2328286	2SC458LG(D)	D805	2339002	DS135D
Q301	2328286	2SC458LG(D)	Q913	2329183	2SA1015(GR)	D806	2339002	DS135D
Q302	2328286	2SC458LG(D)	Q914L,R	2329951	2SD655(D)	D807	2339002	DS135D
Q303	2329183	2SA1015(GR)	Q915	2328286	2SC458LG(D)	D808	2339002	DS135D
Q304	2328286	2SC458LG(D)	Q917	2329183	2SA1015(GR)	D809	2337601	1S2473
Q501	2328286	2SC458LG(D)	Q981	2317782	2SC2235(Y)	D810	2337601	1S2473
Q502	2328286	2SC458LG(D)	Q991	2329183	2SA1015(GR) (for HRD-MD38 W(UN))	D811	2337601	1S2473
Q503	2328286	2SC458LG(D) (for HRD-MD38 ES,VS,BK)	Q992	2328286	2SC458LG(D) (for HRD-MD38 W(UN))	D812	2339001	DS135D(except HRD-MD53 CS,US, HRD-MD38 W(UN))
Q504	2328286	2SC458LG(D) (for HRD-MD38 ES,VS,BK)	Q993	2329183	2SA1015(GR) (for HRD-MD38 W(UN))	D814	2339002	DS135D (for HRD-MD38 W(UN))
Q505	2329183	2SA1015(GR)	DIODES			D815	2339002	DS135D (for HRD-MD53 CS,US, HRD-MD38 W(UN))
Q506	2329183	2SA1015(GR)	D101	2337601	1S2473	D816	2339002	DS135D
Q507	2329183	2SA1015(GR) (for HRD-MD38 ES,VS,BK)	D102	2337601	1S2473	D901	2337601	1S2473
Q508	2329183	2SA1015(GR) (for HRD-MD38 ES,VS,BK)	D103	2337931	1K60R (for HRD-MD38 ZS)	D902	2337601	1S2473
Q631	2328286	2SC458LG(D)	D104	2337931	1K60R (for HRD-MD38 ZS)	D903	2337601	1S2473
Q632	2328286	2SC458LG(D)	D151	2337601	1S2473	D906	2337601	1S2473
Q651	2329183	2SA1015(GR)	D152	2337601	1S2473	D907	2337601	1S2473
Q652	2329183	2SA1015(GR)	D153	2397321	KV1260	D908	2337601	1S2473
Q653	2329183	2SA1015(GR)	D154	2397321	KV1260(for HRD-MD38 ES,VS,BK)	D909	2337601	1S2473
Q654	2329183	2SA1015(GR)	D155	2337601	1S2473(for HRD-MD38 ES,VS,BK)	D914	2337601	1S2473
Q655	2329183	2SA1015(GR)	D156	2337601	1S2473(for HRD-MD38 ES,VS,BK)	D915	2337601	1S2473
Q656	2329183	2SA1015(GR)	D157	2337601	1S2473(for HRD-MD38 ES,VS,BK)	D916	2337601	1S2473 (for HRD-MD38 W(UN))
Q657	2328286	2SC458LG(D)	D158	2337601	1S2473(for HRD-MD38 ES,VS,BK)	D917	2337601	1S2473
Q658	2328286	2SC458LG(D)	D159	2337601	1S2473(for HRD-MD38 ES,VS,BK)	D918	2337601	1S2473 (for HRD-MD38 W(UN))
Q659	2328286	2SC458LG(D)	D201	2337601	1S2473	D991	2337601	1S2473 (for HRD-MD38 W(UN))
Q660	2328286	2SC458LG(D)	D301	2337601	1S2473	D993	2337601	1S2473 (for HRD-MD38 W(UN))
Q661	2328286	2SC458LG(D)	D401	2337601	1S2473	D994	2337601	1S2473 (for HRD-MD38 W(UN))
Q662	2328286	2SC458LG(D)	D402	2337601	1S2473	D998	2337601	1S2473
Q663	2328286	2SC458LG(D)	D501	2337601	1S2473	ZD151	2337616	HZ-3B3(for HRD-MD38 ES,VS,BK)
Q751	2328286	2SC458LG(D)	D502	2337601	1S2473 (except HRD-MD53 CS,US)	ZD501	2337122	HZ-6B(except HRD-MD38 W(UN))
Q801	2328286	2SC458LG(D)	D503	2337601	1S2473	ZD501	2337515	HZ6B-2 (for HRD-MD38 W(UN))
Q802	2317822	2SD880(Y)	D506	2337601	1S2473	ZD502	2337122	HZ-6B
Q803	2328625	2SB647(C)	D507	2337601	1S2473	ZD601	2337589	HZ-5C-3
Q804	2329183	2SA1015(GR)	D508	2337601	1S2473	ZD651	2337431	HZ-3A(except HRD-MD38 W(UN))
Q805	2328286	2SC458LG(D)	D509	2337601	1S2473	ZD651	2337612	HZ-3A2 (for HRD-MD38 W(UN))
Q807	2329183	2SA1015(GR)	D510	2337601	1S2473	ZD801	2337189	HZ-15-3(except HRD-MD38 W(UN))
Q808	2328286	2SC458LG(D)	D511	2337601	1S2473	ZD801	2337533	HRZ-15-3 (for HRD-MD38 W(UN))
Q810	2328625	2SB647(C)	D512	2337601	1S2473	ZD802	2337189	HZ-15-3(except HRD-MD38 W(UN))
Q811	2328625	2SB647(C)	D513	2337601	1S2473 (for HRD-MD53 US,CS, HRD-MD38 W(UN))	ZD802	2337533	HZ-15-3 (for HRD-MD38 W(UN))
Q814	2328625	2SB647(C)	D602	2337601	1S2473			
Q815	2328286	2SC458LG(D)	D656	2337601	1S2473			
Q816	2328625	2SB647(C) (for HRD-MD38 W(UN))	D657	2337601	1S2473			
Q901L,R	2328286	2SC458LG(D)	D658	2337601	1S2473			
Q902	2328286	2SC458LG(D)	D659	2337601	1S2473			
Q903L,R	2328286	2SC458LG(D)	D660	2337601	1S2473			
Q904	2328286	2SC458LG(D)						

SYMBOL No.	PART No.	DESCRIPTION	SYMBOL No.	PART No.	DESCRIPTION	SYMBOL No.	PART No.	DESCRIPTION
R404L,R	0113677	CF 390kΩ ±5% SRD1/6P	R537	0113287	CF 100Ω ±5% SRD1/2P	R705L,R	0113661	CF 82kΩ ±5% SRD1/6P
R405L,R	0113651	CF 33kΩ ±5% SRD1/6P	R538	0113287	CF 100Ω ±5% SRD1/2P	R706L,R	0129609	CF 2.2kΩ ±5% SRD1/4P
R406L,R	0113661	CF 82kΩ ±5% SRD1/6P	R539	0113575	CF 22Ω ±5% SRD1/6P	R707L,R	0129609	CF 2.2kΩ ±5% SRD1/4P
R407	0113621	CF 1.8kΩ ±5% SRD1/6P	R540	0113639	CF 10kΩ ±5% SRD1/6P	△R708	1110611	FR 68Ω ±5% RN1/4B
R408L,R	0113647	CF 22kΩ ±5% SRD1/6P	R541	0113619	CF 1.5kΩ ±5% SRD1/6P	R709	0129635	CF 15kΩ ±5% SRD1/4P
R409L,R	0113637	CF 8.2kΩ ±5% SRD1/6P	R542	0113639	CF 10kΩ ±5% SRD1/6P	R710	0129579	CF 560Ω ±5% SRD1/4P
R411L,R	0113647	CF 22kΩ ±5% SRD1/6P	R543	0113639	CF 10kΩ ±5% SRD1/6P	△R711	1110621	FR 100Ω ±5% RN1/4B
R412L,R	0113637	CF 8.2kΩ ±5% SRD1/6P			(for HRD-MD38	R712L,R	0129531	CF 10Ω ±5% SRD1/4P
R413L,R	0113647	CF 22kΩ ±5% SRD1/6P			ES,VS,BK)	R713L,R	1119029	ME 4.7Ω ±10%RN1B
R414L,R	0113637	CF 8.2kΩ ±5% SRD1/6P	R544	0113663	CF 100kΩ ±5% SRD1/6P	R715L,R	0113293	CF 330Ω ±5% SRD1/2P
R415L,R	0113647	CF 22kΩ ±5% SRD1/6P			(for HRD-MD38	R716L,R	0113293	CF 330Ω ±5% SRD1/2P
R416	0113635	CF 6.8kΩ ±5% SRD1/6P			EW,W(UN))	R717L,R	0113293	CF 330Ω ±5% SRD1/2P
R417	0113639	CF 10kΩ ±5% SRD1/6P	R601L,R	0113663	CF 100kΩ ±5% SRD1/6P	R718L,R	0113293	CF 330Ω ±5% SRD1/2P
R418	0113639	CF 10kΩ ±5% SRD1/6P	R602L,R	0113627	CF 3.3kΩ ±5% SRD1/6P	R751	0113665	CF 120kΩ ±5% SRD1/6P
R419	0113653	CF 39kΩ ±5% SRD1/6P	R603L,R	0113637	CF 8.2kΩ ±5% SRD1/6P	R752	0113665	CF 120kΩ ±5% SRD1/6P
R501	0113623	CF 2.2kΩ ±5% SRD1/6P	R604L,R	0113663	CF 100kΩ ±5% SRD1/6P	R753	0113663	CF 100kΩ ±5% SRD1/6P
R502	0113611	CF 680Ω ±5% SRD1/6P	R605L,R	0113651	CF 33kΩ ±5% SRD1/6P	R755	0113647	CF 22kΩ ±5% SRD1/6P
R503	0113631	CF 4.7kΩ ±5% SRD1/6P	R606L,R	0113643	CF 15kΩ ±5% SRD1/6P	R756	0113667	CF 150kΩ ±5% SRD1/6P
R504	0113635	CF 6.8kΩ ±5% SRD1/6P	R607	1119041	ME 10Ω ±10%RN1B	R759	0129621	CF 6.8kΩ ±5% SRD1/4P
R505	0113635	CF 6.8kΩ ±5% SRD1/6P	R608	0113625	CF 2.7kΩ ±5% SRD1/6P			(for HRD-MD53 CS,US,
		(for HRD-MD38	R609	0113625	CF 2.7kΩ ±5% SRD1/6P	R759	0129617	CF 4.7kΩ ±5% SRD1/4P
		ES,VS,BK)	R631	0113647	CF 22kΩ ±5% SRD1/6P			(except HRD-MD53 CS,
R506	0113639	CF 10kΩ ±5% SRD1/6P	R632	0113667	CF 150kΩ ±5% SRD1/6P			US, HRD-MD38 W(UN))
		(for HRD-MD38	R633	0113647	CF 22kΩ ±5% SRD1/6P	R760	0113647	CF 22kΩ ±5% SRD1/6P
		ES,VS,BK)	R651	0113647	CF 22kΩ ±5% SRD1/6P	R761	0113647	CF 22kΩ ±5% SRD1/6P
R507	0113615	CF 1kΩ ±5% SRD1/6P	R652	0113647	CF 22kΩ ±5% SRD1/6P	R762	0113639	CF 10kΩ ±5% SRD1/6P
		(for HRD-MD38	R653	0113647	CF 22kΩ ±5% SRD1/6P	R763	0113639	CF 10kΩ ±5% SRD1/6P
		ES,VS,BK)	R654	0113647	CF 22kΩ ±5% SRD1/6P	R764	0129621	CF 6.8kΩ ±5% SRD1/4P
R508	0113635	CF 6.8kΩ ±5% SRD1/6P	R655	0113647	CF 22kΩ ±5% SRD1/6P			(for HRD-MD53 CS,US,
		(for HRD-MD38	R656	0113623	CF 2.2kΩ ±5% SRD1/6P	R764	0129617	CF 4.7kΩ ±5% SRD1/4P
		ES(LW),VS,BK(LW))	R657	0113639	CF 10kΩ ±5% SRD1/6P			(except HRD-MD53 CS,
R509	0113587	CF 68Ω ±5% SRD1/6P	R658	0113623	CF 2.2kΩ ±5% SRD1/6P	R765	1119530	MO560Ω ±10%RS2B
R510	0113663	CF 100kΩ ±5% SRD1/6P	R659	0113639	CF 10kΩ ±5% SRD1/6P			(except HRD-MD38
R511	0113663	CF 100kΩ ±5% SRD1/6P	R660	0113623	CF 2.2kΩ ±5% SRD1/6P	R765	1119532	MO820Ω ±10%RS2B
R512	0113663	CF 100kΩ ±5% SRD1/6P	R661	0113639	CF 10kΩ ±5% SRD1/6P			(for HRD-MD38 W(UN),
		(except HRD-MD53 US,	R662	0113623	CF 2.2kΩ ±5% SRD1/6P	R801	0129623	CF 8.2kΩ ±5% SRD1/4P
		CS HRD-MD38 W(UN))	R663	0113639	CF 10kΩ ±5% SRD1/6P			(for HRD-MD53 CS,US,
R513	0113663	CF 100kΩ ±5% SRD1/6P	R664	0113623	CF 2.2kΩ ±5% SRD1/6P	R801	0129617	CF 4.7kΩ ±5% SRD1/4P
R514	0113663	CF 100kΩ ±5% SRD1/6P	R665	0113639	CF 10kΩ ±5% SRD1/6P			(except HRD-MD53 CS,
R515	0113663	CF 100kΩ ±5% SRD1/6P	R666	0113639	CF 10kΩ ±5% SRD1/6P	R802	1119159	ME 47Ω ±10%RN2B
R516	0113637	CF 8.2kΩ ±5% SRD1/6P	R667	0113647	CF 22kΩ ±5% SRD1/6P			(for HRD-MD53 CS,US,
R517	0113637	CF 8.2kΩ ±5% SRD1/6P	R668	0113639	CF 10kΩ ±5% SRD1/6P	R802	1119152	ME 12Ω ±10%RN2B
R518	0113637	CF 8.2kΩ ±5% SRD1/6P	R669	0113605	CF 390Ω ±5% SRD1/6P			(except HRD-MD53 CS,
R520	0113595	CF 150Ω ±5% SRD1/6P	R670	0113615	CF 1kΩ ±5% SRD1/6P	R803	1119159	ME 47Ω ±10%RN2B
R521	0113633	CF 5.6kΩ ±5% SRD1/6P	R671	0113639	CF 10kΩ ±5% SRD1/6P			(for HRD-MD53 CS,US,
R522	0113663	CF 100kΩ ±5% SRD1/6P	R672	0113615	CF 1kΩ ±5% SRD1/6P	R803	1119152	ME 12Ω ±10%RN2B
R523	0113655	CF 47kΩ ±5% SRD1/6P	R673	0113615	CF 1kΩ ±5% SRD1/6P			(except HRD-MD53 CS,
R524	0113615	CF 1kΩ ±5% SRD1/6P	R674	0113635	CF 6.8kΩ ±5% SRD1/6P	R804	0113615	CF 1kΩ ±5% SRD1/6P
R525	0113655	CF 47kΩ ±5% SRD1/6P	R675	0113639	CF 10kΩ ±5% SRD1/6P	R805	0129623	CF 8.2kΩ ±5% SRD1/4P
R526	0113655	CF 47kΩ ±5% SRD1/6P	R676	0113639	CF 10kΩ ±5% SRD1/6P			(for HRD-MD53 CS,US,
R527	0129601	CF 1kΩ ±5% SRD1/4P	R677	0113639	CF 10kΩ ±5% SRD1/6P			HRD-MD38 W(UN))
R528	0113659	CF 68kΩ ±5% SRD1/6P	R678	0113639	CF 10kΩ ±5% SRD1/6P	R802	1119152	ME 12Ω ±10%RN2B
R529	0129601	CF 1kΩ ±5% SRD1/4P	R679	0113639	CF 10kΩ ±5% SRD1/6P			(except HRD-MD53 CS,
R530	0113639	CF 10kΩ ±5% SRD1/6P	R680	0113575	CF 22Ω ±5% SRD1/6P	R803	1119159	ME 47Ω ±10%RN2B
		(for HRD-MD38	R681	0113615	CF 1kΩ ±5% SRD1/6P			(for HRD-MD53 CS,US,
		ES,VS,BK)	R682	0113615	CF 1kΩ ±5% SRD1/6P	R803	1119152	ME 12Ω ±10%RN2B
R531	0113663	CF 100kΩ ±5% SRD1/6P	R683	0113615	CF 1kΩ ±5% SRD1/6P			(except HRD-MD53 CS,
		(for HRD-MD38	R701L,R	0113623	CF 2.2kΩ ±5% SRD1/6P	R804	0113615	CF 1kΩ ±5% SRD1/6P
		ES,VS,BK)	R702L,R	0113661	CF 82kΩ ±5% SRD1/6P	R805	0129623	CF 8.2kΩ ±5% SRD1/4P
R532	0113655	CF 47kΩ ±5% SRD1/6P	R703L,R	0113609	CF 560Ω ±5% SRD1/6P			(for HRD-MD53 CS,US,
		(for HRD-MD38 ZS)			(for HRD-MD53 CS,US,			HRD-MD38 W(UN))
R532	0113663	CF 100kΩ ±5% SRD1/6P			(except HRD-MD53 SRD1/6P	R805	0129617	CF 4.7kΩ ±5% SRD1/4P
		(except HRD-MD38 ZS)			(except HRD-MD53 CS,			(except HRD-MD53 CS,
R533	0113615	CF 1kΩ ±5% SRD1/6P			US, HRD-MD38 W(UN))			US, HRD-MD38 W(UN))
R534	0113615	CF 1kΩ ±5% SRD1/6P	R704L,R	0113647	CF 22kΩ ±5% SRD1/6P			
R536	0113639	CF 10kΩ ±5% SRD1/6P						

SYMBOL No.	PART No.	DESCRIPTION	SYMBOL No.	PART No.	DESCRIPTION	SYMBOL No.	PART No.	DESCRIPTION
R806	0129569	CF 220Ω ±5% SRD1/4P (for HRD-MD53 CS,US, HRD-MD38 W(UN))	R929L,R	0113631	CF 4.7kΩ ±5% SRD1/6P	R971	0113649	CF 27kΩ ±5% SRD1/6P
R806	0129567	CF 180Ω ±5% SRD1/4P (except HRD-MD53 CS, US, HRD-MD38 W(UN))	R930	0113663	CF 100kΩ ±5% SRD1/6P	R972	0113639	CF 10kΩ ±5% SRD1/6P
R807	0113615	CF 1kΩ ±5% SRD1/6P	R931L,R	0113647	CF 22kΩ ±5% SRD1/6P	R973	0113611	CF 680Ω ±5% SRD1/6P
R808	0113639	CF 10kΩ ±5% SRD1/6P	R932L,R	0113641	CF 12kΩ ±5% SRD1/6P	R976L,R	0113653	CF 39kΩ ±5% SRD1/6P
R809	0113639	CF 10kΩ ±5% SRD1/6P	R933L,R	0113635	CF 6.8kΩ ±5% SRD1/6P	R977	0113639	CF 10kΩ ±5% SRD1/6P
△R814	1110623	FR 150Ω ±5% RN1/4B (for HRD-MD53 CS,US, HRD-MD38 W(UN))	R934L,R	0113647	CF 22kΩ ±5% SRD1/6P	R978	0113639	CF 10kΩ ±5% SRD1/6P
R814	0119444	MO1.8kΩ ±10%RS1B (except HRD-MD53 CS, US, HRD-MD38 W(UN))	R935L,R	0113619	CF 1.5kΩ ±5% SRD1/6P	R979	0113639	CF 10kΩ ±5% SRD1/6P
△R815	1110602	FR 12Ω ±5% RN1/4B	R936L,R	0113585	CF 56Ω ±5% SRD1/6P	R981	0113567	CF 10Ω ±5% SRD1/6P
R816	0129617	CF 4.7kΩ ±5% SRD1/4P	R937L,R	0113615	CF 1kΩ ±5% SRD1/6P	R982	0113649	CF 27kΩ ±5% SRD1/6P
R817	0113615	CF 1kΩ ±5% SRD1/6P	R938L,R	0113625	CF 2.7kΩ ±5% SRD1/6P	R983	0113295	CF 470Ω ±5% SRD1/2P
R818	1119159	ME47Ω ±10%RN2B (for HRD-MD53 CS,US, HRD-MD38 W(UN))	R939L,R	0113627	CF 3.3kΩ ±5% SRD1/6P	△R984	1110609	FR 47Ω ±5% RN1/4B
R819	0129601	CF 1kΩ ±5% SRD1/4P	R940	0113639	CF 10kΩ ±5% SRD1/6P	R985	0113591	CF 100Ω ±5% SRD1/6P (for HRD-MD38 ES(LW),VS,BK(LW))
R820	1119159	ME47Ω ±10%RN2B (for HRD-MD53 CS,US, HRD-MD38 W(UN))	R941	0113639	CF 10kΩ ±5% SRD1/6P	R986	0113605	CF 390Ω ±5% SRD1/6P (for HRD-MD38 W(UN))
R821	0129601	CF 1kΩ ±5% SRD1/4P	R942	0113647	CF 22kΩ ±5% SRD1/6P	R988	0113647	CF 22kΩ ±5% SRD1/6P (for HRD-MD38 W(UN))
R828	0129601	CF 1kΩ ±5% SRD1/4P	R943	0113647	CF 22kΩ ±5% SRD1/6P	R989	0113639	CF 10kΩ ±5% SRD1/6P (for HRD-MD38 W(UN))
R829	0113639	CF 10kΩ ±5% SRD1/6P	R944	0113647	CF 22kΩ ±5% SRD1/6P	R990	0113639	CF 10kΩ ±5% SRD1/6P (for HRD-MD38 W(UN))
R830	0113639	CF 10kΩ ±5% SRD1/6P	R945	0113639	CF 10kΩ ±5% SRD1/6P	R991	0113639	CF 10kΩ ±5% SRD1/6P (for HRD-MD38 W(UN))
R831	0113647	CF 22kΩ ±5% SRD1/6P	R946	0113665	CF 120kΩ ±5% SRD1/6P (except HRD-MD38 W(UN))	R992	0113637	CF 8.2kΩ ±5% SRD1/6P (for HRD-MD38 W(UN))
R834	0113655	CF 47kΩ ±5% SRD1/6P	R946	0113633	CF 5.6kΩ ±5% SRD1/6P (for HRD-MD38 W(UN))	R993	0113645	CF 18kΩ ±5% SRD1/6P (for HRD-MD38 W(UN))
R835	0113647	CF 22kΩ ±5% SRD1/6P	R947	0113633	CF 5.6kΩ ±5% SRD1/6P (except HRD-MD38 W(UN))	R994	0113633	CF 5.6kΩ ±5% SRD1/6P (for HRD-MD38 W(UN))
R837	0129601	CF 1kΩ ±5% SRD1/4P (for HRD-MD38 W(UN))	R947	0113643	CF 15kΩ ±5% SRD1/6P (for HRD-MD38 W(UN))	R996	0113613	CF 820Ω ±5% SRD1/6P (for HRD-MD38 W(UN))
△R838	1110625	FR 220Ω ±5% RN1/4B	R948	0113591	CF 100Ω ±5% SRD1/6P (except HRD-MD38 W(UN))	R997	0113639	CF 10kΩ ±5% SRD1/6P (for HRD-MD38 W(UN))
R839	0113647	CF 22kΩ ±5% SRD1/6P	R948	0113635	CF 6.8kΩ ±5% SRD1/6P (for HRD-MD38 W(UN))	R998	0113639	CF 10kΩ ±5% SRD1/6P (for HRD-MD38 W(UN))
R901L,R	0113579	CF 33Ω ±5% SRD1/6P	R949	0113663	CF 100kΩ ±5% SRD1/6P	R999	0113639	CF 10kΩ ±5% SRD1/6P (for HRD-MD38 W(UN))
R902L,R	0113663	CF 100kΩ ±5% SRD1/6P	R950	0113657	CF 56kΩ ±5% SRD1/6P	J103	0113591	CF 100Ω ±5% SRD1/6P (for HRD-MD38 ZS)
R903L,R	0113627	CF 3.3kΩ ±5% SRD1/6P	R951	0113631	CF 4.7kΩ ±5% SRD1/6P (except HRD-MD38 W(UN))	ICS & TRAMSOSTPRS		
R904	0113651	CF 33kΩ ±5% SRD1/6P	R951	0113647	CF 22kΩ ±5% SRD1/6P (for HRD-MD38 W(UN))	IC1	2300841	BA3812L
R905	0113651	CF 33kΩ ±5% SRD1/6P	R952	0113639	CF 10kΩ ±5% SRD1/6P	IC2	2300841	BA3812L
R906L,R	0113623	CF 2.2kΩ ±5% SRD1/6P	R953	0113639	CF 10kΩ ±5% SRD1/6P (except HRD-MD38 W(UN))	IC201	2368431	AN278
R907L,R	0113627	CF 3.3kΩ ±5% SRD1/6P (except HRD-MD38 W(UN))	R953	0113651	CF 33kΩ ±5% SRD1/6P (for HRD-MD38 W(UN))	IC202	2300412	LA1265S
R907L,R	0113623	CF 2.2kΩ ±5% SRD1/6P (for HRD-MD38 W(UN))	R956	0113639	CF 10kΩ ±5% SRD1/6P	IC301	2300561	LA3361
R908	0113625	CF 2.7kΩ ±5% SRD1/6P	R957	0113661	CF 82kΩ ±5% SRD1/6P	IC401	2300831	μPC4558C
R909L,R	0113639	CF 10kΩ ±5% SRD1/6P	R958	0113639	CF 10kΩ ±5% SRD1/6P	IC402	2387564	TC9152P
R910L,R	0113647	CF 22kΩ ±5% SRD1/6P	R959L,R	0113639	CF 10kΩ ±5% SRD1/6P	IC501	2368741	μPB553AC
R911	0113639	CF 10kΩ ±5% SRD1/6P	R960L,R	0113657	CF 56kΩ ±5% SRD1/6P	IC502	2369722	μPD1704C-531
R912	0113651	CF 33kΩ ±5% SRD1/6P	R961L,R	0113633	CF 5.6kΩ ±5% SRD1/6P	IC503	2387421	AN6873N
R913L,R	0113639	CF 10kΩ ±5% SRD1/6P	R962L,R	0113639	CF 10kΩ ±5% SRD1/6P (except HRD-MD38 W(UN))	IC504	2387611	BA6251
R914L,R	0113639	CF 10kΩ ±5% SRD1/6P	R962L,R	0113615	CF 1kΩ ±5% SRD1/6P (for HRD-MD38 W(UN))	IC601	2300831	μPC4558C
R916	0113651	CF 33kΩ ±5% SRD1/6P	R966L,R	0113663	CF 100kΩ ±5% SRD1/6P	IC602	2301701	BA6209N
R917	0113639	CF 10kΩ ±5% SRD1/6P	R967	0113607	CF 470Ω ±5% SRD1/6P (except HRD-MD38 W(UN))	IC651	2301602	μPD7564-072
R918L,R	0113619	CF 1.5kΩ ±5% SRD1/6P	R967	0113631	CF 4.7kΩ ±5% SRD1/6P (for HRD-MD38 W(UN))	IC701	2301161	STK4142 II (except HRD-MD53 CS, US, HRD-MD38 W(UN))
R919L,R	0113623	CF 2.2kΩ ±5% SRD1/6P	R968	0113611	CF 680Ω ±5% SRD1/6P (except HRD-MD38 W(UN))	IC701	2301151	STK4192 II (for HRD-MD53 CS,US, HRD-MD38 W(UN))
R920L,R	0113663	CF 100kΩ ±5% SRD1/6P	R969	0113647	CF 22kΩ ±5% SRD1/6P	IC751	2387581	μPC1237H
R921	0113647	CF 22kΩ ±5% SRD1/6P				IC901	2301052	BA3416BL
R922	0113647	CF 22kΩ ±5% SRD1/6P				IC902	2300831	μPC4558C
R923L,R	0113633	CF 5.6kΩ ±5% SRD1/6P				IC903	2301201	HA12086
R924	0113647	CF 22kΩ ±5% SRD1/6P				IC904	2300831	μPC4558C
R925	0113647	CF 22kΩ ±5% SRD1/6P						
R926	1119425	MO220Ω ±10%RS1B						
R927L,R	0113639	CF 10kΩ ±5% SRD1/6P						
R928L,R	0113631	CF 4.7kΩ ±5% SRD1/6P						

SYMBOL No.	PART No.	DESCRIPTION	SYMBOL No.	PART No.	DESCRIPTION	SYMBOL No.	PART No.	DESCRIPTION
ZD805	2337188	HZ-24-2	L154	2136494	OSC coil (for HRD-MD38 ES,VS,BK)	X501	2789281	Crystal oscillator (4.5MHz)
ZD901	2337431	HZ-3A (except HRD-MD38 W(UN))	L631	2227912	Choke coil 2.2 μ H	X651	2155222	Ceramic oscillator
ZD901	2337612	HZ-3A2 (for HRD-MD38 W(UN))	L701L,R	2227361	Audio trap coil 0.67 μ H	RY701	2647711	DH relay
LED504	2339102	SLP-160C	L901L,R	2227991	Choke coil 3.3mH	JK701	2689551	4P push terminal
LED505	2339102	SLP-160C	L902L,R	2227395	Choke coil 1mH	JK702	2678448	Head phone jack
LED651	2338891	SLP-151B	L981	2136823	Bias osc coil 85kHz	FL501	2789303	Fluorescent display tube
LED652	2338891	SLP-151B	T201	2137033	FM discriminator coil	IRR601	2377731	GP1U501
LED653	2338891	SLP-151B	T202	2154493	AM IF transformer	RP501	0189014	Resistor array (100k \times 7)
LED654	2338891	SLP-151B	T401	2689621	6Pus pin terminal	RP502	0189031	Resistor array (39k \times 4)
LED655	2338891	SLP-151B	MISCELLANEOUS			FE101	2425461	Juner pack (except HRD-MD38 ZS)
LED661	2338507	SLR-54URC1	CP101	2137301	Band pass filter (for HRD-MD38 ZS)	FE101	2425561	Tuner pack (for HRD-MD38 ZS)
LED971	2339104	SLP-660C	CP301	2136313	Low pass filter (for HRD-MD38 ZS)	MF201	2134982	FM ceramic filter MA5 (for HRD-MD53 CS,US)
LED972	2339104	SLP-660C	CP501	0241892	Capacitor array (330P \times 7)	MF201	2135002	Ceramic filter MS2 (except HRD-MD53 CS,US)
LED973	2339104	SLP-660C	Δ F001	2727962	Fuse (3A 125V) (for HRD-MD53 CS,US)	MF202	2135002	Ceramic filter MS2 (for HRD-MD38 ZS)
LED974	2339104	SLP-660C	Δ F001	2727742	Fuse T1A 250V (except HRD-MD53 CS, US, HRD-MD38 W(UN))	MF203	2134982	FM ceramic filter MA5 (for HRD-MD53 CS,US)
LED975	2339102	SLP-160C	Δ F801	2727961	Fuse 2A 125V (for HRD-MD53 CS,US)	MF203	2135002	Ceramic filter MS2 (except HRD-MD53 CS,US)
LED976	2339102	SLP-160C	Δ F801	2727745	Fuse (T2A) (except HRD-MD53 CS,US)	MF204	2155152	AM ceramic filter
LED977	2339102	SLP-160C	Δ F802	2728183	Micro fuse (0.2A)	AT101	2689601	Antenna terminal 2P (except HRD-MD38 ZS)
LED995	2338893	SLP-151B-60 (for HRD-MD38 W(UN))	Δ F803	2728184	Micro fuse (0.5A)	AT102	2689603	Antenna terminal 3P
LED996	2338893	SLP-151B-60 (for HRD-MD38 W(UN))	Δ F804	2728182	Micro fuse (0.1A)	4847131	TD P.W.B. assy (for HRD-MD53 US)	
VARIABLE RESISTORS			S501	2639682	Tact switch	4847132	TD P.W.B. assy (for HRD-MD53 CS)	
RT301	0158955	10k Ω -(B)MPX. FREE RUN ADJ.	S502	2639682	Tact switch	4847133	TD P.W.B. assy (for HRD-MD38 BS)	
RT901L,R	0158954	5k-(B) REC LABEL.	S503	2639682	Tact switch	4847134	TD P.W.B. assy (for HRD-MD38 KS)	
RT902	0158954	5k Ω -(B) TAPE SPEED (except HRD-MD38 W(UN))	S504	2639682	Tact switch	4847135	TD P.W.B. assy (for ES,VS)	
RT902	0158955	10k Ω -(B) TAPE SPEED (for HRD-MD38 W(UN))	S505	2639682	Tact switch	4847136	TD P.W.B assy (for HRD-MD38 ZS)	
RT903L,R	0158958	100k Ω -(B) BIAS ADJ.	S506	2639682	Tact switch	4847137	TD P.W.B. assy (for HRD-MD38 AU)	
RT991	0158955	10k Ω -(B) TAPE SPEED ADJ. (for HRD-MD38 W(UN))	S507	2639682	Tact switch	4847138	TD P.W.B. assy (for HRD-MD38 EW)	
RT992	0158955	10k Ω -(B) TAPE SPEED NORMAL TAPE 1 (for HRD-MD38 W(UN))	S508	2639682	Tact switch	4849071	TD P.W.B. assy (for HRD-MD38 W(UN))	
RT993	0158955	10k Ω -(B) TAPE SPEED HIGH TAPE 1 (for HRD-MD38 W(UN))	S509	2639682	Tact switch	4847151	Power P.W.B. assy (for HRD-MD53 US)	
RV1	0166577	100k Ω -(B) G.EQ. VOLUME	S510	2639971	Tact switch	4847152	Power P.W.B. assy (for HRD-MD53 CS)	
RV2	0166577	100k Ω -(B) G.EQ. VOLUME	S511	2639971	Tact switch	4847153	Power P.W.B. assy (for HRD-MD38 BS)	
RV3	0166577	100k Ω -(B) G.EQ. VOLUME	S512	2639682	Tact switch	4847154	Power P.W.B. assy (for HRD-MD38 KS)	
RV4	0166577	100k Ω -(B) G.EQ. VOLUME	S513	2639971	Tact switch	4847155	Power P.W.B. assy (for HRD-MD38 ES,VS)	
RV5	0166577	100k Ω -(B) G.EQ. VOLUME	S514	2639971	Tact switch	4847156	Power P.W.B. assy (for HRD-MD38 ZS)	
RV6	0166579	200k Ω BALANCE	S515	2639971	Tact switch (for HRD-MD38 ES,VS,BK)	4847157	Power P.W.B. assy (for HRD-MD38 AU)	
RV601	0189113	100k Ω -(B) VOLUME ADJ.	S516	2639971	Tact switch	4847158	Power P.W.B. assy (for HRD-MD38 EW)	
RV901	0166838	10k Ω -(B) REC LABEL ADJ.	S517	2629381	Slide sw (for HRD-MD38 EW,W(UN))	4849062	Power P.W.B. assy (for HRD-MD38 W(UN))	
COILS			S651	2639682	Tact switch			
L151	2137373	ANT coil	S652	2639682	Tact switch			
L152	2136493	OSC coil	S653	2639682	Tact switch			
L153	2137374	ANT coil (for HRD-MD38 ES,VS,BK)	S654	2639682	Tact switch			
			S655	2639682	Tact switch			
			S656	2639682	Tact switch			
			S901	2628325	SLIDE switch			
			S902	2600283	1 key push switch			
			S903	2600049	1 key push switch			
			S904	2600501	2 key push switch			
			S905	2600501	2 key push switch			
			S981	2629381	Slide switch (for HRD-MD38 ES,VS,BK)			
			LC901L,R	2228104	Dolby filter			
			LC902L,R	2136791	Bias trap coil 85k			

■ Cassette chassis TAPE 1 (TN-222F-147)

SYMBOL No.	PART No.	DESCRIPTION	SYMBOL No.	PART No.	DESCRIPTION	SYMBOL No.	PART No.	DESCRIPTION
1	4819081	Head panel	52	4819123	Push button actuator spring	104	4819171	Damper spring
2	4819082	CHP lever	53	4819124	Switch actuator	105	4819172	FL patch plate
3	4819083	Slide lever collar	54	4819125	RWD lever	106	4819173	M collar screw (motor)
4	4819084	Head panel spring	55	4819223	PLAY button lever	107	4819174	Motor rubber
5	4819085	Head base	56	4819224	REWIND button lever	109	4819176	Switch base assy
6	4819086	Head plate	57	4819225	FF button lever	112	3800421	Operation lever
7	4819087	Head SP plate	58	4819226	STOP button lever	113	4819232	Button lever shaft
8	2557571	Head	59	4819227	PAUSE button lever assy	120	4819185	Spring
12	4819089	Take-up roller plate (R) assy	60	4819131	PAUSE lever	200	4819186	Screw (2×3) (chassis)
13	4819080	Take-up roller plate assy (F)	61	4819132	PAUSE lever spring	201	4819187	Fine screw (2×10) (head)
14	4819091	Take-up roller assy	62	4819133	PAUSE stopper	203	4819188	Camera screw (2×2.5) (CHP lever)
15	4819092	Pinch roller arm (R) assy	63	4819134	M function lever	204	4819189	Camera screw (2×8.5) (FL metal)
16	4819093	C.H.P. lever collar A	64	4819137	Function lever spring	205	4819180	Polyslider washer (1.2)
17	4819094	Collar	65	4819138	RF clutch assy	206	4819191	Tapping screw (2×6) (pinch roller arm)
18	4819095	FL metal (R)	66	4819139	RF clutch arm spring	207	4819192	Tapping screw (2×3) (pack SP plate)
19	4819096	Pinch roller arm (F) assy	67	4819140	P trigger arm spring	209	4819194	Polyslider washer (2.1)
20	4819097	Pinch roller spring	68	4819141	Lift arm assy	210	4819195	Tapping screw (2×5) (E slide lever)
21	4819098	FL metal (F)	69	4819142	M trigger arm spring	211	4819196	E ring
22	4819099	Take-up roller spring (F)	70	4819143	M trigger arm assy	212	4819197	P tapping screw (2×6) (chassis)
23	4819090	Take-up roller spring (R)	71	4819144	M gear	213	4819198	Camera screw (2×3) (CH slide lever)
24	4819101	Control lever	72	4819145	CH lever assy	214	4819199	Camera screw (2×1.5) (switch SP plate)
25	4819238	Reel (R) assy	73	4819147	CH lever spring	215	4819190	E ring
28	4819105	Reel (F) assy	74	4819148	CH gear assy	216	4819201	Camera screw (2×3.5) (P trigger arm, RF trigger arm)
29	4819106	Spring	75	4819149	P gear	217	4819202	Camera screw (2×4.5) (RF lever, P actuator assy)
30	4819107	Main base assy	76	4819150	P trigger arm spring	218	4819203	E ring
33	4819108	Leaf switch (MOTOR SWITCH)	77	4819151	P trigger collar	219	4819204	Pan head screw (2×3) (switch base)
34	4819109	Button lever spring	78	4819152	P trigger arm	220	4819234	Camera screw (2×8) (button frame)
35	4819100	Button lever spring	79	4819153	RF trigger arm	221	4819205	Polyslider washer (2.2)
37	4819111	Pack SP plate	80	4819154	RF collar	222	4819206	Nylon washer (2.1)
38	4819112	FF gear	81	4819155	P actuator arm assy	223	4819207	Wire
39	4819113	Pinch roller arm spring (R)	82	4819156	P actuator arm spring	224	4819208	Screw (switch base) (2×3)
40	4819114	Pinch roller arm spring (F)	83	4819157	Cam gear plate assy	225	4718209	Damper spring
41	4819115	E slide lever	84	4819158	Sensor plate spring	226	4819235	Motor assy
42	4819116	Collar	85	4819159	Cam gear plate spring			
43	4819117	E slide lever spring	86	4819160	Cam gear			
45	4819119	Slide lever	87	4819161	Pulley			
46	4819110	Switch SP plate	88	4819162	Full auto belt			
50	4819121	T.P.S.function lever	89	4819163	RF lever			
51	4819122	Push button actuator assy	90	4819164	Sensing plate			
			91	4819165	Control lever			
			92	4819166	Control lever spring			
			93	4819167	FL pulley capstan assy			
			94	4819168	FL gear capstan assy			
			95	4819228	Main belt			
			96	4819160	Leaf switch (PLAY SWITCH, FF/REWSWITCH)			
			97					
			98					
			99					
			100					
			101					
			102					
			103					

■ Cassette chassis TAPE 2 (TN-29F-210)

SYMBOL No.	PART No.	DESCRIPTION	SYMBOL No.	PART No.	DESCRIPTION	SYMBOL No.	PART No.	DESCRIPTION
2	4818992	Switch plate	15	4819005	Button lever spring	32	4819010	Pressure roller assy
3	4818993	Push button actuator assy	16	4819006	PR stopper	33	4819021	Pressure roller spring
4	4819522	REC button lever	17	4819007	Button lever spring	34	4819022	RF pulley arm assy
5	4819523	PLAY button lever	18	4819008	Actuator spring	35	4819023	RF pulley arm spring
6	4819524	RWD button lever	19	4819009	Auto lever	36	4819024	RF belt
7	4819525	FF button lever	20	4819010	Auto lever spring	37	4819025	RF arm collar screw
8	4819526	STOP button lever	22	4819011	Leaf switch (MOTOR SWITCH)	38	4819520	Flywheel assy
9	4819527	PAUSE button lever assy	25	4819013	Head panel assy	41	4819028	Take-up gear plate assy
10	4818990	RWD lever	26	4819528	Head base	42	4819029	Takeup roller gear
11	4819131	PAUSE lever	27	4819015	Sensing plate assy	43	4819020	TG plate spring
12	4819132	PAUSE lever spring	28	4819016	Head panel spring	44	4819112	FF gear
13	4819133	PAUSE stopper	29	4819017	Spring	45	4819032	Spring
14	4819100	Button lever spring	30	4819529	E.H. spring	46	4819003	Supply reel assy
						47	4819004	Take-up reel assy

SYMBOL No.	PART No.	DESCRIPTION	SYMBOL No.	PART No.	DESCRIPTION	SYMBOL No.	PART No.	DESCRIPTION
	4847141	Front P.W.B. assy (for HRD-MD53 US)		4477552	Rear plate (for HRD-MD53 CS)	19	3950381	Damper assy
	4847142	Front P.W.B. assy (for HRD-MD53 CS)		4477553	Rear plate (for HRD-MD38 BK)	20	3804742	Reverse knob (for HRD-MD38 W(UN))
	4847143	Front P.W.B. assy (for HRD-MD38 BS)		4477554	Rear plate (for HRD-MD38 KS)	21	3804761	Direction knob (for HRD-MD38 W(UN))
	4847144	Front P.W.B. assy (for HRD-MD38 KS)		4477555	Rear plate (for HRD-MD38 ES, VS)	22	3804752	Reverse holder (for HRD-MD38 W(UN))
	4847145	Front P.W.B. assy (for HRD-MD38 ES, VS)		4477559	Rear plate (for HRD-MD38 ZS)	23	3804812	Preset knob
	4847146	Front P.W.B. assy (for HRD-MD38 ZS)		4477557	Rear plate (for HRD-MD38 AU)	24	3307304	Tuning button
	4847147	Front P.W.B. assy (for HRD-MD38 AU)		4477558	Rear plate (for HRD-MD38 EW, W(UN))	25	3307252	REC vol knob
	4847148	Front P.W.B. assy (for HRD-MD38 EW)	7	3927411	Foot	26	3802002	REC holder
	4849061	Front P.W.B. assy (for HRD-MD38 W(UN))	8	3368853	REC spring (except HRD-MD38 W(UN))	27	3805191	Operating button (REC)
	4847139	SW P.W.B. assy (except HRD-MD38 W(UN))		3391864	REC spring (for HRD-MD38 W(UN))	28	3805192	Operating button (PLAY)
	4849072	SW P.W.B. assy (for HRD-MD38 W(UN))	9	9502401	Bottom board	29	3805193	Operating button (REW)
	4847149	KEY P.W.B. assy (except HRD-MD38 W(UN))	10	2706584	Power supply cord (for HRD-MD38 EW, W(UN))	30	3805194	Operating button (FF)
	4849063	KEY P.W.B. assy (for HRD-MD38 W(UN))		2702713	Power supply cord (for HRD-MD53 US, CS)	31	3805195	Operating button (STOP EJECT)
	4847159	VOL P.W.B. assy (except HRD-MD38 W(UN))		2748752	Power supply cord (for HRD-MD38 ZS, ES, VS, KS)	32	3805196	Operating button (PAUSE)
	4849064	VOL P.W.B. assy (for HRD-MD38 W(UN))		2749622	Power supply cord (for HRD-MD38 AU)	33	3307323	Operating button (PLAY) (except W(UN))
	3804721	FM led holder		2749582	Power supply cord (for HRD-MD38 BK)	34	3307322	Operating button (PLAY) (for W(UN))
	3806551	Shift led holder		3913006	Bushing(4N-4) (except HRD-MD38 EW, W(UN))	35	2589322	MECHANISM assy (TN-21SW-985) deck (except HRD-MD38 W(UN))
	3804801	FL holder	11	0043793	Bushing(3P-4) (for HRD-MD38 EW, W(UN))	36	2588743	TN-29F-210 (TAPE2) (for HRD-MD38 W(UN))
	3802042	Led holder		3805341	Bushing 4.5 (for HRD-MD38 W(UN))	37	2588734	TN-222F-147 (TAPE1) MECHANISM ASSY (for HRD-MD38 W(UN))
	3806551	Fun led holder		2658372	AC outlet (for HRD-MD53 CS, US)	38	4691911	Counter belt
	2596502	GE P.W.B.		2618053	Voltage switch (for HRD-MD38 EW, W(UN))	39	4468981	REC lever (B) (except HRD-MD38 W(UN))
for ACCESARIES				3308751	Function button	40	4475601	REC plate (for HRD-MD38 W(UN))
	2758341	AM loop antenna		3804732	Power button (except HRD-MD38 W(UN))	41	3368841	REC wire (except HRD-MD38 W(UN))
	2757527	FM antenna (except HRD-MD38 ZS)	△12	4043731	Power button (HRD-MD53 US, CS, HRD-MD38 W(UN))	42	4475821	Eject spring (1) (except HRD-MD38 W(UN))
	2589331	Rimocon unit		3307202	Push button	43	4475831	Eject spring (2) (except HRD-MD38 W(UN))
	2667922	Siemens plug (for HRD-MD38 W(UN))	△13	3804781	Speed knob	44	3391922	Eject spring (for HRD-MD38 W(UN))
	2727745	Fuse T2A 250V (for HRD-MD38 W(UN))	14	4042832	Front panel assy (for HRD-MD53 CS, US)	45	2588921	Counter
CABINET CHASSIS ASSEMBLY			15	4042833	Front panel assy (for HRD-MD38 BK, ES, VS)	46	2727671	Fuse holder (for W(UN))
1	4469054	Top case		4042834	Front panel assy (for HRD-MD38 AU, ZS, KS)	47	3931571	Holder, ANTENNA
2	3807011	Cassette door (1) (except HRD-MD38 W(UN))		4042835	Front panel assy for HRD-MD38 W(UN))	48	4575661	Earth screw
	3802069	Cassette door (1) (for HRD-MD38 W(UN))	16			49	4408861	Washer
3	3807012	Cassette door (2) (except HRD-MD38 W(UN))	17			50	4575453	DT bind screw (with washer)
	3802060	Cassette door (2) (for HRD-MD38 W(UN))	18			51	4567432	DT bind screw (3×8)
4	3301181	Slide knob				52	8691410	BT bind head screw (3×10)
5	3805211	Main volume				53	8691412	BT bind head screw (3×12)
6	4477551	Rear plate (for HRD-MD53 US)				54	4567442	BT screw (3×20) (for HRD-MD38 W(UN))
						55	4833465	Screw
						56	4567442	DT bind screw (4×8)

SYMBOL No.	PART No.	DESCRIPTION	SYMBOL No.	PART No.	DESCRIPTION	SYMBOL No.	PART No.	DESCRIPTION
57	4567411	DT bind head screw (3×6)	66	4573552	Tapping bind head screw (3×16)	△	2249943	Power transformer W (for HRD-MD38 EW)
58	4584792	DT screw (2×5) (except HRD-MD38 W(UN))	70	2677911	FM ANTENNA SOCKET (except HRD-MD53 CS, US, HRD-MD38 ZS)	SPEAKER BOX (for W(UN))		
59	8699408	BT bind head screw (3×8)	71	2658391	DIN ANT SOCKET (for HRD-MD38 ZS)	101	9502391	Cabinet (Speaker)
60	8691408	BT bind head screw (3×8)	△72	2249931	Power transformer 120V (for HRD-MD53 CS,US)	102	4043382	SP gill
61	8751413	Tapping pan head screw (3.1×13)	△	2249932	Power transformer W (for HRD-MD38 W(UN))	103	2403942	Speaker (16cm)
62	4575444	DT bind screw (with washer 3×12)	△	2249941	Power transformer 220V (for HRD-MD38 ZS, ES,VS,KS)	104	2403931	Speaker (4.5cm)
63	0681276	Washer (3.3×10)	△	2249942	Power transformer 240V (for HRD-MD38 AU, BK,VS)	105	2712271	Speaker cord
64	4784106	Tapping bind head screw (3×10)				106	2403353	Tweeter
65	4578973	BT Flange screw (for HRD-MD38 W(UN))				107	4567442	DT bind screw (3×8)
						108	4577816	BT screw (3×20)
						109	4855041	Screw wood 3.5×20
						110	4597171	Flange wood screw (3.5×8)
						111	4597172	Flange wood screw (3.5×12)

■ Cassette chassis (TN-21SW-985)

PARTS NO.	PART NO.	DESCRIPTION	PARTS NO.	PART NO.	DESCRIPTION	PARTS NO.	PART NO.	DESCRIPTION
1	4818991	MAIN base assy	36	4850693	Pinch roller arm spring	74	4819191	Tapping screw (2x6)
2	4818992	Switch plate	37	4833455	Pause bracket	75	4819611	Screw (2x6)
3	4839371	Push button actuator assy	38	4831610	Metal guide	76	4839383	Anti vibration felt mat
4	4823651	REC button lever	39	4839373	RF pulley arm assy	77	4819060	Screw (2x7)
5	4823661	PLAY button lever	40	4820225	RF pulley arm spring	78	4819600	Azimuth screw
6	4823671	RWD button lever	41	4835913	RF arm collar screw	79	4819202	Camera screw (2x4.5)
7	4823681	FF button lever	42	4820227	Belt	80	4832471	Camera screw (M2x2.5)
8	4823691	STOP button lever	43	4839374	Flywheel assy	81	4832472	Camera screw (M1.7x4.5)
9	4823701	PAUSE button lever	44	4839375	Flywheel assy	82	4850697	Camera screw (1.7x3)
10	4818990	RWD lever	46	4839377	TAKE UP gear plate assy	83	4850698	Washer (1.55)
11	4833451	PAUSE lever	47	4839378	TAKE UP roller gear	84	4819078	Washer (1.55)
12	4819132	PAUSE lever spring	48	4819020	TG plate spring	85	4832432	Washer (2.05)
13	4819133	PAUSE stopper	49	4839379	FF gear	86	4819528	Head base
14	4850692	Button lever spring	50	4839370	Back tension spring	87	4831623	Operation lever
15	4820215	SUB chassis	51	4842431	Supply reel assy	88	4831624	B frame
16	4819007	Button lever spring	52	4839381	TAKE UP reel assy	89	4819232	Button lever shaft
17	4820217	PLAY button lever spring	53	4832421	Record safety lever	90	4819072	Screw (2x7)
18	4831614	Head panel	54	4839382	Back tension spring	91	4833463	Lever
19	4819008	Actuator spring	55	4835915	Motor bracket	92	4833464	Lever
20	4819009	AUTO lever	56	4819039	Motor rubber	93	4833465	Special screw
21	4819000	AUTO lever spring	57	4819533	Motor collar screw	94	4833460	Collar (B)
22	4820214	Button lever spring	59	4833457	Belt	95	4833467	Spring
23	4832091	Leaf switch	60	4848086	Mat	96	4832102	Switch leaf
24	4832522	Screw	61	4833452	Record plate	97	4833468	Collar
25	4820219	Head panel	62	4819043	Eject slide lever	98	4850699	Lever
26	4832451	RWD button lever	63	4819044	Eject slide lever spring	99	4835917	Switch bracke
27	4819014	Head base	64	4819036	Pack spring	100	4468971	REC lever (A)
28	4832412	Sensing plate assy	65	2557522	P head	101	4850690	Leaf switch
29	4832452	FF button lever	66	2557521	R/P head	102	4850694	Leaf switch
30	4820221	Head panel	67	2557531	E head	103	4819195	Tapping screw (2x5)
31	4832482	SUB plate	68	4831657	Motor assy	104	4833472	Tapping screw (2x6)
32	4819006	PR stopper	69	4820218	Switch actuator spring	105	4691911	Counter belt
33	4819045	Screw	70	4819186	Screw (2x3)	106	4819529	E.H. spring
34	4819017	Spring	71	4819063	Tapping screw (2x3)	107	4850702	Washer (2.4)
35	4839372	Pinch roller arm assy	72	4819068	Tapping screw (2x4)	108	4819544	Cap screw (2x8)
			73	4819607	Bind tapping screw (2x5)			

SYMBOL No.	PART No.	DESCRIPTION	SYMBOL No.	PART No.	DESCRIPTION	SYMBOL No.	PART No.	DESCRIPTION
48	4819035	Record safety lever	74	4819053	REC sensor spring	91	4819204	Pan head screw (2×3) (sub chassis)
49	4819036	Pack spring	75	4819054	REC function arm B	92	4819542	Pan head screw (2×7) (R/P head)
50	4819037	Spring	76	4819055	REC spring	94	4819060	Screw (2×7) (R/P head)
53	4819039	Motor rubber	77	4819056	REC arm spring (B)	95	4819544	Cap screw (2×8) (erase head)
54	4819533	Motor collar screw (motor)	78	4819057	REC arm spring (A)	97	4819072	Screw (2×7) (frame)
56	4819534	Main belt	79	4819058	Main gear	98	4819073	Screw (2×5) (REC sensor)
59	4819535	Eject slide lever	82	2557561	R/P head	99	4819196	E ring
60	4819044	Eject slide lever spring	83	4819541	Erase head	103	4819077	Washer (1.2)
61	4819045	Screw (eject slide lever)	86	4819062	Lug	104	4819078	Washer (1.55)
62	4819002	Screw	87	4819063	Tapping screw (2×3) (pack spring)	105	4819079	Washer (2.2)
63	4819536	Frame	88	4819064	Bind tapping screw (2×4) (sub chassis)	106	4819546	Motor assy
64	4819537	Operation lever	89	4819195	Tapping screw (2×5) (sub chassis)	130	4475591	REC lever
65	4819538	Button lever shaft	90	4819066	Tapping screw (2×3.5) (reel base)	131	4578281	DT screw (2.6×4)
70	4819049	Main gear spring						
71	4819539	REC function arm (A)						
72	4819051	REC sensor						
73	4819052	REC sensor collar						

■ Turntable (HT-MD28)

SYMBOL NO.	PART NO.	DESCRIPTION	SYMBOL NO.	PART NO.	DESCRIPTION	SYMBOL NO.	PART NO.	DESCRIPTION
1	4817521	EP adaptor	19	4835682	Pendulum	37	4835716	Spring
2	4835737	Carn gear assy	20	4835683	Hinge assy	38	4835717	Spring
3	4835738	Platter assy	21	4835743	Motor assy	39	4835718	Spring
4	4835739	Return link assy	22	4835693	Micro switch	40	4835719	Steel crammer
5	4835665	Starting lever	23	4835694	Push switch	41	4835721	Spring
6	4835730	Pick-up stand assy	24	4835697	DC board	42	4835723	Pendulum
7	4835741	Tone arm assy	25	4835695	5P Connector ass'y	43	4835724	Belt
8	4835668	Knob shaft	26	4835696	P.C. board	44	4835725	Rubber tube
9	4835669	Oil shaft	27	4835703	Screw	45	4835726	Rubber foot (L)
10	4835660	Press set	28	4835704	Screw	46	4835728	Rubber mat
11	4835671	Lifter	29	4835706	Screw	47	4817549	Washer
12	4835675	Pendulum set	30	4835707	Screw	48	4835729	Washer
13	3307471	Push button	31	4835708	Screw	49	4817557	Washer
14	3307461	Push button	32	4835709	Screw	50	4835731	Washer
15	4835745	Dust cover assy	33	4835700	Screw	51	4835734	Washer
16	4835676	Platter shaft assy	34	4835712	Screw	52	4835735	Washer
17	4835670	Press plate	35	4835713	Screw	53	4835736	Steel ball
18	4835681	Hanging plate for motor	36	4835715	Screw	54	4850561	Player base assy



HITACHI SALES EUROPA GmbH
Rungedamm 2, 2050 Hamburg 80, West Germany
Tel. 040-734 11-0

HITACHI SALES (U.K.) Ltd.
Hitachi House, Station Road, Hayes, Middlesex UB3
4DR, England
Tel. 01-848-8787

HITACHI SALES SCANDINAVIA AB
Rissneleden 8, Box 7138, 172-07 Sundbyberg, Sweden
Tel. 08-98 52 80

HITACHI SALES NORWAY A/S
P.O. Box 503, Oerebeek. 1620, Gressvik, Norway
Tel. 032-28255

SUOMEN HITACHI OY
Takojanokatu 5, 15800 Lahti 80, Finland
Tel. (918) 44 241

HITACHI SALES A/S
Kuldysen 13, DK-2630, Taastrup, Denmark
Tel. 02-999200

HITACHI SALES A.G.
Bahnhofstrasse, 19, 5600 Lenzburg, Switzerland
Tel. 064-513621

HITACHI SALES WARENHANDELS GMBH
A-1180/Wien, Kreuzgasse 27, Austria
Tel. 0222-421670

HITACHI SALES ITALIANA, S.P.A.
Via Cristoforo Colombo 49, Trezzano sul naviglio
(Milano), Italy
Tel. 44 59 031

HITACHI SALES BELGIUM S.A./N.V.
Chaussee de Namur, 56, B-1400 Nivelles, Belgium
Tel. (3267) 21-71-81, (3267) 21-79-81

HITACHI SALES IBERICA, S.A.
Gran Via Carlos Tercero, 101, 1-1, Barcelona 8028
Spain
Tel. 330-8652

**HITACHI PRODUCTIONS MAROC ELECTRONIQUES
DOMESTIQUES S.A.**
Rue du Havre, Casablanca, Morocco
Tel. 30-73-68, 30-73-57

HITACHI CANARIAS S.A.
Calle San-Francisco No. 19, 38002, Santa Cruz de Tenerife
Canary Islands
Tel. 24-64-98

HITACHI SALES (HELLAS), S.A.
110 Syngrou St., Athens, Greece
Tel. 9219082, 9233469

HITACHI SALES (MALAYSIA) SDN. BHD.
Wisma Hitachi No. 2 Lorong 13/6A. 46200
Petaling Jaya, Malaysia
Tel. 7573455

HITACHI (SINGAPORE) PTE., LTD.
18, Pasir Panjang Road # 01-03 PSA Multi-Storey
Complex Singapore 0511
Tel. 2738102

HITACHI SALES (THAILAND) LTD.
2240-46, New Petchburi Road, Bangkapi, Hueykuang
Bangkok, Thailand
Tel. 314-2741

HITACHI ELECTRIC SERVICE CO., (HONG KONG) LTD.
4th Floor Leun Tai Industrial Bldg., 72-76 Kwai Cheong
Road Kwai Chung N.T., Hong Kong
Tel. 0-242976, 0-240126

HITACHI SALES AUSTRALIA PTY LTD.
153 Keys Road, Moorabbin, Victoria 3189 Australia
Tel. 555-8722

**HITACHI SALES CORPORATION OF AMERICA
Eastern Regional Office**
1290 Wall Street West, Lyndhurst, New Jersey 07071, U.S.A.
Tel. 201-935-8980

Mid-Western Regional Office
1400 Morse Ave., Elk Grove Village,
Illinois 60007, U.S.A.
Tel. 312-593-1550

Southern Regional Office
510 Plaza Drive, College Park, Georgia 30349, U.S.A.
Tel. 404-763-0360

Headquarters Western Regional Office
401 West Artesia Boulevard, Compton, California 90220
U.S.A.
Tel. 213-537-8383

HITACHI SALES CORPORATION OF HAWAII, INC.
3219 Koapaka Street. Honolulu, Hawaii 96819, U.S.A.
Tel. 808-836-3621

HITACHI (HSC) CANADA INC.
3300 Trans-Canada Highway, Pointe Claire, Quebec,
H9R 1B1, Canada
Tel. 514-697-9150

**Hitachi Sales Centroamericans, S.A.
HITACHI ELECTRONICA CENTROAMERICANA, S.A.**
San Rafael de Excazu, (Apartado 10272), San Jose,
Costa Rica
Tel. 28-20-11, 28-00-37

**Hitachi Sales Corporation de Panama, S.A.
INTERNATIONAL HITACHI SALES PANAMA, LTD.
PRODUCTOS HITACHI, S.A.**
Apartado 7657 Panama 5 Panama City, Rep. of Panama
Tel. 61-3100, 61-4305

**HITACHI-FRANCE
(RADIO-TV ELECTRO-MENAGER) S.A.**
95-101 Rue Charles Michels,
93200 SAINT-DENIS,
France
Tel. 821 6015

HITACHI LTD. TOKYO JAPAN
Head Office : THE HITACHI ATAGO BLDG.
No. 15-12, 2-Chome Nishi-Shinbashi
Minato-ku, Tokyo 105, Japan
Tel. Tokyo (03) 502-2111