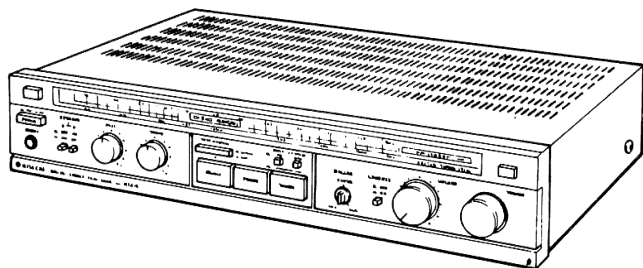

HITACHI

SERVICE MANUAL

TY**No. 358 EGF****HTA-2****CONTENTS · INHALT · SOMMAIRE**

SPECIFICATIONS · TECHNISCHE DATEN · CARACTERISTIQUES TECHNIQUES	1,2,3
DIAL CORD SETTING · SKALENSEILEINSTELLUNG · EQUIPEMENT DE CADRAN	3
DISASSEMBLY AND REPLACEMENT · ZERLEGUNG UND AUSTAUSCH · DEMONTAGE ET REMONTAGE	4
FM TUNER ALIGNMENT · ABGLEICH DES UKW-TUNERS · REGLAGE DE TUNER FM	5,6
AM TUNER ALIGNMENT · ABGLEICH DES MW-TUNERS · REGLAGE DE TUNER AM	7,8
GENERAL ALIGNMENT INSTRUCTION · ALLGEMEINE ABGLEICHANLEITUNG · INSTRUCTION GENERALE DE REGLAGE	8
PRINTED WIRING BOARD · PRINTPLATTEN · PLAN DE BASE	9
CIRCUIT DIAGRAM · SCHALTPLAN · PLAN DE CIRCUIT	10,11
BLOCK DIAGRAM · BLOCK SCHEMA · SCHEMA	12
REPLACEMENT PARTS LIST · ERSATZTEILISTE · TABLEAU DES PIECE	13,14,15,16
FRONT AND REAR PANEL · VORDERE UND HINTERE BEDIENUNGSTAFEL · PANNEAUX AVANT ET ARRIERE	17

SAFETY PRECAUTIONS

The following precautions should be observed when servicing.

1. Since many parts in the unit have special safety related characteristics, always use genuine Hitachi's replacement parts. Especially critical parts in the power circuit block should not be replaced with other makers. Critical parts are marked with Δ in the circuit diagram and printed wiring board.
2. Before returning a repaired unit to the customer, the service technician must thoroughly test the unit to ascertain that it is completely safe to operate without danger of electrical shock.

SICHERHEITSMASSNAHMEN

Bei Wartungsarbeiten sind die folgend Sicherheitsmaßnahmen zu beachten:

1. Da verschiedene Teile dieses Gerätes Sicherheitsfunktionen aufweisen, nur Original-Hitachi-Ersatzteile verwenden. Kritische Teile im Netzteil sollten nicht durch ähnliche Teile anderer Hersteller ersetzt werden. Alle kritischen Teile sind im Schaltplan und im Diagramm der Schaltplattinen mit dem Symbol Δ gekennzeichnet.
2. Vor der Auslieferung eines reparierten Gerätes an den Kunden muß der Wartungstechniker das Gerät einer gründlichen Prüfung unterziehen, um sicherzustellen, daß sicherer Betrieb ohne die Gefahr von elektrischen Schlägen gewährleistet ist.

PRÉCAUTIONS DE SÉCURITÉ

Les précautions suivantes doivent être observées chaque fois qu'une réparation doit être faite.

1. Etant donné que de nombreux composants de l'appareil possèdent des caractéristiques relatives à la sécurité, utiliser uniquement des pièces de rechange d'origine Hitachi pour effectuer un remplacement. Ceci se rapporte notamment aux pièces critiques du bloc d'alimentation qui ne doivent en aucun cas être remplacées par celles d'autres fabricants. Les pièces critiques sont accompagnés du symbole Δ dans le schéma de montage et sur le schéma de plaque de câblage.
2. Avant de retourner l'appareil réparé au client le technicien doit procéder à un essai complet pour s'assurer qu'il ne présente aucun danger de chocs électriques.

SPECIFICATIONS AND PARTS ARE SUBJECT TO CHANGE FOR IMPROVEMENT.

STEREO RECEIVER

May**1983****TOYOKAWA WORKS**

SPECIFICATIONS

FM SECTION

Frequency range	88 – 108 MHz
Usable sensitivity (Mono)	13.2 dBf (IHF) / 1.6 μ V (DIN)
50 dB quieting sensitivity	Mono : 18.2 dBf (4.5 μ V) Stereo : 38.2 dBf (44.7 μ V)
Signal-to-noise ratio (at 65 dBf)	Mono : 76 dB (IHF) / 70 dB (DIN) Stereo : 70 dB (IHF) / 65 dB (DIN)
Total harmonic distortion (at 65 dBf, 1 kHz)	Mono : 0.15 % Stereo : 0.25 %
Frequency response	30 Hz – 12 kHz (± 2 dB) (except W. Germany) 30 Hz – 12 kHz (± 1.0 dB) (for W. Germany)
Selectivity	53 dB (± 300 kHz IHF) (except W. Germany, U.S.A. and Canada) 65 dB (± 300 kHz IHF) (for W. Germany) 53 dB (± 400 kHz IHF) (for U.S.A. and Canada)

AM SECTION

Frequency range	530 – 1,620 kHz
Sensitivity	50 μ V (IHF, ext. Antenne)
Selectivity	38 dB
Signal-to-noise ratio (at 50 mV/m)	45 dB

AUDIO SECTION

RMS Power (Both channels driven)	25 Watts per channel, min. RMS, at 8 ohms from 40 Hz to 20 kHz, with no more than 0.1% total harmonic distortion. 27 W + 27 W (8 ohms, 1 kHz, T.H.D. 0.1% IHF)
---	---

Power bandwidth	10 Hz – 30 kHz (1/2 RMS power, T.H.D. 0.1% at 8 ohms)
Frequency characteristics	10 Hz – 40 kHz (± 2 dB)
Total harmonic distortion (at rated output)	Less than 0.1%
Intermodulation distortion (at 1/2 rated output)	0.05%
Input sensitivity/Impedance (at 25 W output, 1 kHz)	
PHONO	2.5 mV / 47 k ohms
TAPE, CD/VIDEO/AUX	150 mV / 35 k ohms
Phono overload level	120 mV (T.H.D. 0.05% at 1 kHz)
Output level (TAPE OUT)	150 mV (PHONO at rated input) 150 mV (FM 400 Hz, 30% mod. input 1 mV) 150 mV (AM 400 Hz, 30% mod. input 5 mV/m)
Signal-to-noise ratio (IHF, A network, rated power)	
PHONO	70 dB
TAPE, CD/VIDEO/AUX	95 dB
GENERAL	
Power requirements	AC 120 V, 60 Hz, ~ 220 V, 50/60 Hz ~ 240 V 50/60 Hz or ~ 120 V/220 V/240 V 50/60 Hz
Power consumption	150 W (except U.S.A. and Canada) 100 W (for U.S.A. and Canada)
Dimensions	435(W) \times 83(H) \times 282(D) mm
Weight	5.4 kg

TECHNISCHE DATEN

UKW-TEIL

Frequenzbereich	88 – 108 MHz
Nutzempfindlichkeit (Mono)	13,2 dBf (IHF) / 1,6 μ V (DIN)
50-dB-Geräuschberuhigung	Mono : 18,2 dBf (4,5 μ V) Stereo : 38,2 dBf (44,7 μ V)
Signal-Rauschspannungsabstand (bei 65 dBf)	Mono : 76 dB (IHF) / 70 dB (DIN) Stereo : 70 dB (IHF) / 65 dB (DIN)
Gesamtklirrfaktor (bei 65 dBf, 1 kHz)	Mono : 0,15% Stereo : 0,25%
Frequenzgang	30 Hz – 12 kHz (± 2 dB) (außer die Bundesrepublik Deutschland) 30 Hz – 12 kHz (± 1.0 dB) (für die Bundesrepublik Deutschland)
Trennschärfe	53 dB (± 300 kHz IHF) (außer USA, Kanada und die Bundesrepublik Deutschland) 65 dB (± 300 kHz IHF) (für die Bundesrepublik Deutschland)

MW-TEIL

Frequenzbereich	530 – 1620 kHz
Eingangsempfindlichkeit	50 μ V (IHF, Außenantenne)
Trennschärfe	38 dB
Signal-Rauschspannungsabstand (bei 50 mV/m)	45 dB

VERSTÄRKERTEIL

Effektivleistung (bei Aussteuerung beider Kanäle)	25 Watts \times 2 min. RMS an 8 Ohm von 40 Hz bis 20 kHz mit nicht mehr als 0,1% Gesamtklirrfaktor
Leistungsbandbreite	27 W + 27 W (8 Ohm, 1 kHz, THD 0,1% IHF) 10 Hz – 30 kHz (1/2 Effektivleistung, THD 0,1% an 8 Ohm)

Frequenzgang	10 Hz – 40 kHz (± 2 dB)
Gesamtklirrfaktor (bei Nennausgangsleistung)	weniger als 0,1%
Intermodulationsverzerrungen (bei 1/2 Nennausgangsleistung)	0,05%
Eingangsempfindlichkeit Impedanz (bei 25 W Ausgangsleistung, 1 kHz)	
PHONO	2,5 mV / 47 kOhm
TAPE, CD/VIDEO/AUX	150 mV / 35 kOhm
Übersteuerungsfestigkeit der Phonoeingänge	120 mV (THD 0,05% bei 1 kHz)
Ausgangspegel (TAPE OUT)	150 mV (PHONO bei Nennleistung) 150 mV (UKW 400 Hz, 30% Modulationsgrad 1 mV) 150 mV (MW 400 Hz, 30% Modulationsgrad 5 mV/m)
Geräuschspannungsabstand (IHF, A-Bewertungsfilter, Nennleistung)	
PHONO	70 dB
TAPE, CD/VIDEO/AUX	90 dB
ALLGEMEINES	
Stromversorgung	Wechselstrom 120 V 60 Hz, ~ 220 V 50/60 Hz ~ 240 V 50/60 Hz oder ~ 120 V/220 V/240 V 50/60 Hz
Leistungsaufnahme	150 W (außer USA und Kanada) 100W (für USA und Kanada)
Abmessungen	435(B) \times 83(H) \times 282(T) mm
Gewicht	5,4 kg

CARACTERISTIQUES TECHNIQUES

SECTION FM

Bande de fréquences	88 - 108 MHz
Sensibilité utilisable (Mono)	13,2 dBf (IHF) / 1,6 µV (DIN)
Seuil de sensibilité 50 dB	Mono : 18,2 dBf (4,5 µV) Stéréo : 38,2 dBf (44,7 µV)
Rapport signal/bruit (à 65 dB)	Mono : 76 dB (IHF) / 70 dB (DIN) Stéréo : 70 dB (IHF) / 65 dB (DIN)
Distorsion harmonique totale (à 65 dBf, 1 kHz)	Mono : 0,15% Stéréo : 0,25%
Réponse de fréquence	30 Hz - 12 kHz (±2 dB) (sauf l'Allemagne de l'Ouest) 30 Hz - 12 kHz (±1,0 dB / -6,0 dB) (pour l'Allemagne de l'Ouest)
Sélectivité	53 dB (±300 kHz IHF) (sauf USA, Canada et l'Allemagne de l'Ouest) 65 dB (±300 kHz IHF) (pour l'Allemagne de l'Ouest)

SECTION AM

Bande de fréquence	530 - 1620 kHz
Sensibilité	50 µV (IHF, Antenne extérieure)
Sélectivité	38 dB
Rapport signal/bruit (à 50 mV/m)	45 dB

SECTION AUDIO

Puissance efficace (Les deux canaux entraînés)	25 watts par canal, min. eff. à 8 ohms de 40 Hz à 20 kHz, avec une distorsion harmonique totale ne dépassant pas 0,1% 27W + 27W (8 ohms, 1 kHz, DHT 0,1% IHF)
---	---

Bande passante	10 Hz - 30 kHz (1/2 puis. eff., DHT 0,1% à 8 ohms)
Réponse de fréquence	10 Hz à 40 kHz (±2 dB)
Distorsion harmonique totale (à la puissance nominale)	Inférieure à 0,1 %
Distorsion d'intermodulation (à 1/2 de la puissance nominale)	0,05%
Sensibilité/impédance d'entrée (à une sortie de 25 W, 1 kHz)	
PHONO	2,5 mV / 47 k ohms
TAPE, CD/VIDEO/AUX	150 mV / 35 k ohms
Seuil de surcharge phono	120 mV (DHT 0,05% à 1 kHz)
Niveau de sortie (TAPE OUT)	150 mV (PHONO à entrée nominale) 150 mV (FM 400 Hz, 30% mod., entrée : 1 mV) 150 mV (AM 400 Hz, 30% mod., entrée : 5 mV/m)

Rapport signal / bruit (IHF, Réseau A, puissance nominale)

PHONO	70 dB
TAPE, CD/VIDEO/AUX	95 dB

DONNÉES GÉNÉRALES

Allimentation	CA 120 V, 60 Hz, ~ 220 V 50/60 Hz ~ 240 V 50/60 Hz ou ~ 120 V/220 V/240 V 50/60 Hz
Consommation	150 W (sauf USA et Canada) 100 W (pour USA et Canada)
Dimensions	435(L) × 83(H) × 282(P) mm
Poids	5,4 kg

DIAL CORD SETTING · SKALENSEILEINSTELLUNG · EQUIPEMENT DE CADRAN

Specification :

After setting the dial cord, make the pointer go and return three times within the pointer stroke (the variable capacitor opens and closes three times). When the cord tension is thus equalized, make adjustment so that the tip (a) of the trigger spring matches with the point (b) shown on the pulley. Set the zero point of the pointer in this status.

Spezifikation :

Bewegen Sie den Zeiger nach dem Einstellen der Skalantriebsschnur 3 mal über den gesamten Bewegungsbereich hin und her (der Drehkondensator wird 3 mal geöffnet und geschlossen). Wenn die Schnurspannung auf diese Weise ausgeglichen worden ist, so führen Sie Einstellung so durch, daß die Spitze (a) der Auslösefeder mit dem auf der Schnurscheibe gezeigten Punkt (b) übereinstimmt. Stellen Sie den Nullpunkt des Zeigers in diesem Zustand ein.

Spécifications :

Après l'installation de la corde à cadran, faire va-et-vient de l'aiguille trois fois dans la course de l'aiguille (le condensateur variable s'ouvre et se ferme trois fois). Lorsque la tension de la corde est ainsi égalisée, régler de sorte que le bout (a) du ressort de détente corresponde au point (b) indiqué sur la poulie. Régler le point zéro de l'aiguille à cet état.

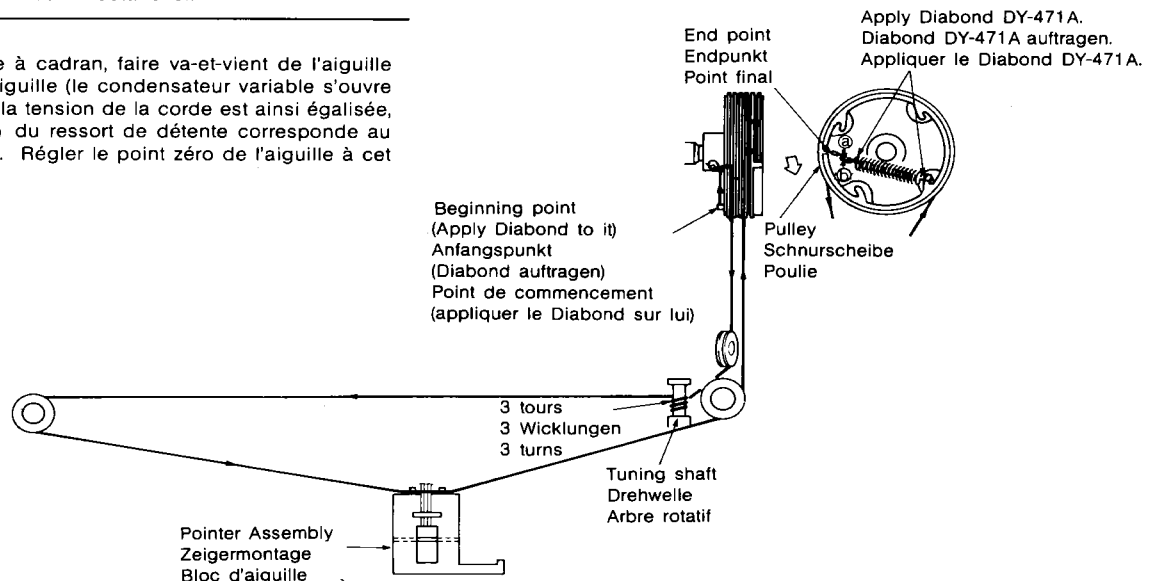

DISASSEMBLY AND REPLACEMENT · ZERLEGUNG UNG AUSTAUSCH · DEMONTAGE ET REMONTAGE

1. By loosening the screw ①, the cover can be removed.
2. Loosen the screws ② through ⑥, raise the rear plate slightly and slightly pull the front panel forward.
3. The board can be set upright with the rear plate and front panel kept mounted.

1. Wenn die Schraube ① entfernt wird, kann die abdeckung entfernt werden.
2. Entfernen Sie die Schrauben ② bis ⑥, heben Sie das hintere Blech etwas an, und ziehen Sie die Frontplatte etwas nach vorne heraus.
3. Die Grundplatte kann aufgestellt werden, während hinteres Blech und Frontplatte angebracht sind.

1. En desserrant la vis ①, on peut enlever le couvercle.
2. Desserrer les vis ② à ⑥, lever un peu la plaque arrière et extraire légèrement en avant le tableau avant.
3. On peut redresser la plaquette la plaque arrière et le tableau avant maintenus associés.

- Removing the printed wiring boards
- Ausbau der Leiterplatten
- Déposer des plaquettes à circuit imprimé

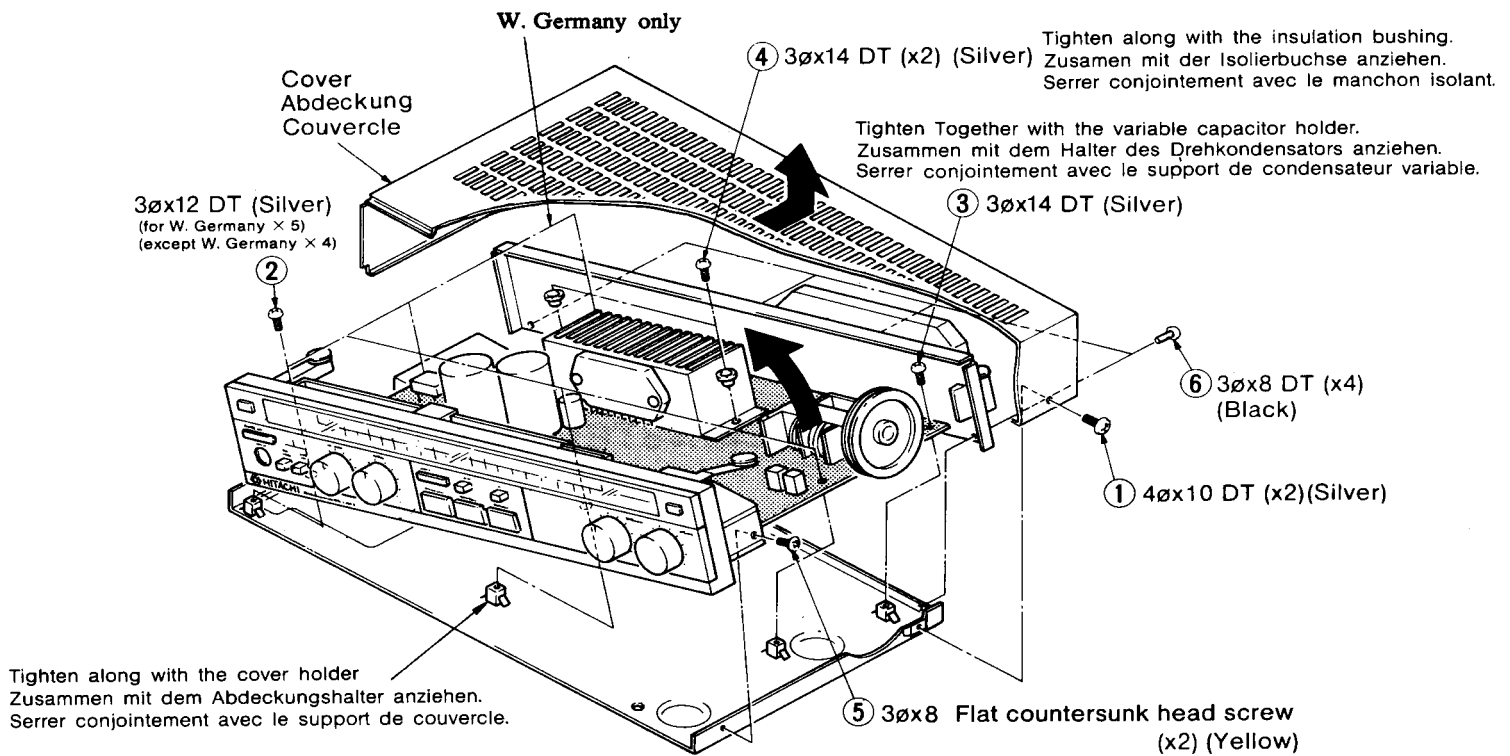





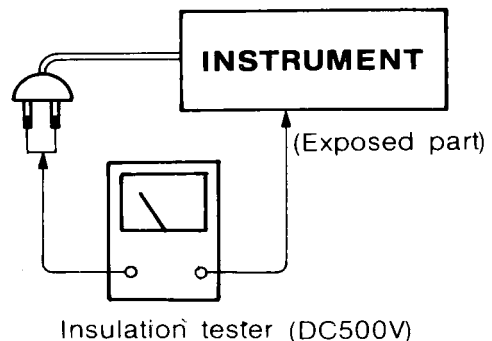

Check that exposed parts are acceptably insulated from the supply circuit before returning the instrument repaired to the customer.

● **Checking method**

Power switch is set to ON.
Next, measure the resistance value between the both poles of attachment cup (Power supply plug) and the exposed parts (Parts such as Ground terminal, Knob, Cover, etc. where the customer is easy to touch.) and check that the resistance value is 500 kohms or more.





FM TUNER ALIGNMENT · ABGLEICH DES UKW-TUNERS · REGLAGE DE TUNER FM

- | | | | |
|---|--|--|--|
|  Sweep Generator
Wobbelgenerator
Générateur de balayage |  Signal Generator
Signalgenerator
Générateur de signaux |  Oscilloscope
Oszilloskop
Oscilloscope |  DC Balance Meter
Gleichstromabgleichprüfer
Indicateur d'équilibre C.C. |
|  Volt Meter
Voltmeter
Voltmètre |  Frequency Counter
Frequenzzähler
Compteur de fréquence |  Dist.
Distortion Meter
Verzerrungsmesser
Compteur de distorsion | |

Condition / Bedingung / Condition: Function: TUNER / Funktion: Tuner / Fonction: dispositif d'accord
 BAND: FM / Wellenbereich: UKW / Bande: FM
 FM MODE: MONO (MUTE OFF) / UKW-Betriebsart: Mono (Geräuschsperre: Ausgeschaltet) / Mode FM: MONO (MUTE OFF)

Modulation: 400 Hz, 100 % (Unless otherwise notified)
 Modulation: 400 Hz, 100 % (wenn nicht anders angegeben)
 Modulation: 400 Hz, 100 % (à moins de notification contraire)

Sequence Reihenfolge Séquence	Connection Anschluß Connexion		Setting Einstellung Réglage		Adjust for Einstellen für Ajustage		
	Input Eingang Entrée	Output Ausgang Sortie	Tuning Abstimmung Syntonisation	Signal	Adjust Einstellung Ajustage	Indication Anzeige Indication	
1	IF Amp. ZF-Verstärker Amp. IF	IN Eingang Entrée TP. 3 100 k 0.1 μ		10.7 MHz	T101	 MAX Caution 1, 2 Vorsicht 1, 2 Précautions 1, 2	
2	"S" curve S-Kurve Courbe en S	OUT Ausgang Sortie TP. 1 100 k 0.1 μ	IN Eingang Entrée TP. 4 100 k 0.1 μ	10.7 MHz	T201, 202 T201: "S" curve S-Kurve Courbe en S T201: Straight line Gerade Linie Ligne directe	 A C B Caution 3 Vorsicht 3 Précaution 3	
3	Covering Abgleich Couverture	ANT. Terminal Antennenanschluß Borne d'antenne ANT. Low level INPUT (6 dBμ) Eingang mit niedrigem Pegel Entrée bas niveau (6 dBμ) Caution 5 Vorsicht 5 Précaution 5	REC OUT	f max 108 MHz	TC5	V max	
4	Tracking Vorstufe Alignement			f min 87.5 MHz	L5	V max	
				90 MHz	L1 ~ L4	V max	
				106 MHz	TC1, TC3	V max	
5	Discr. Trennschärfe Discrim.	300 ohms ANT. Terminal Antennenanschluß Borne d'antenne ANT. 60 dBμ input 60 dBμ Eingang Entrée 60 dBμ	TP. 5 TP. 6	98 MHz	98 MHz	T201	TP. 5,6 - + : 0 V ±30 mV
6	Distortion Verzerrung Distorsion	400 Hz 40 kHz dev. 40 kHz Abweichung 40 kHz dév.	Dist.	98 MHz	98 MHz	T202	Distortion Caution 6 Verzerrung Vorsicht 6 Distorsion Précaution 6
7	(FM MODE: AUTO) (UKW-Betriebsart: Auto) (MODE FM: AUTO) 76 kHz	Non-modulated Nicht moduliert Non modulé	TP.	98 MHz	98 MHz	R316	Freq. Frequenz Fréq. 76 kHz ±100 Hz
8	(FM MODE: AUTO) (UKW-Betriebsart: Auto) (MODE FM: AUTO) Stereo Distortion Stereoverzerrung Distorsion stéréo- phonique	L + R 40 kHz Pilot 6 kHz	Dist.			T101	Distortion Verzerrung Distorsion

CAUTION

- (1) Input low level signals (such that noises are mixed together as is shown in Fig. 1) from the sweep generator. Setting the gain to maximum with T101, adjust the waveform until it appears like that shown in Fig. 1. The ground side of the sweep generator output dummy should be connected to the local oscillator shielded plate.
- (2) Inputting high level signals from the sweep generator, adjust the waveform with T101 until it becomes like that shown in Fig. 2.
- (3) Adjusting the T201, obtain an S-curve as shown in Fig. 3. Then adjust the T202 to make the amplitude of the S-curve maximum with points A and B symmetrical with respect to point C and the slope as linear as possible.
- (4) FM Tuner pack is aligned before shipping, so it is not necessary to adjust covering and tracking. If you moved the capacitance (TC1, TC3) or coil (L1~L4) by mistake, it is necessary to adjust it.
- (5) Set the input level to 60 dB μ in coarse adjustment. Reduce the input level to minimum (6 dB μ) as adjustment proceeds.
- (6) As the result of the adjustment step 6, the best point of adjustment from step 5 will be shifted a bit. Repeat the adjustment of step 5 and 6 until the deterioration becomes minimum and the DC balance meter shows 0 \pm 30 mV.
- (7) Connect the ground side of the sweep generator output dummy to the local oscillator shielded plate. Adjust the variable capacitor so that it has minimum capacitance.
- (8) Adjusting L151 core, make a waveform as in Fig. 4. Because of the ceramic filter used, the markers may be out of position. If this happens, neglect the markers.
- (9) Set the input level to 74 dB/m in coarse adjustment. Reduce the input level to minimum (52 dB/m) as adjustment proceeds.

VORSICHT

- (1) Geben Sie Signale mit niedrigem Pegel (die wie in Abb. 1 gezeigt Rauschen enthalten) vom Wobbelgenerator her ein. Stellen Sie mit T101 auf maximalen Verstärkungsgrad ein, und stellen Sie dann die Wellenform so ein, daß sie wie in Abb. 1 gezeigt wird. Die Erdseite des Blindausgangs des Wobbelgenerators sollte an das lokale Oszillatorabschirmblech angeschlossen werden.
- (2) Geben Sie Signale mit hohem Pegel vom Wobbelgenerator her ein, und stellen Sie die Wellenform mit T101 ein, bis sie wie in Abb. 2 gezeigt wird.
- (3) Stellen Sie T201 so ein, daß eine S-Kurve wie in Abb. 3 gezeigt erhalten wird. Stellen Sie dann T202 so ein, daß die Maximalamplitudenpunkte A und B der S-Kurve symmetrisch zum Punkt C und die Steigung so linear wie möglich wird.
- (4) Der UKW-Tunerteil ist vor dem Versand eingestellt worden, so daß Bereich und Nachführung nicht eingestellt werden müssen. Wenn Sie versehentlich eine Kapazität (TC1, TC3) oder eine Spule (L1 bis L4) verstellt haben, so ist Einstellung erforderlich.
- (5) Stellen Sie den Eingangspegel in grober Einstellung auf 60 dB μ ein. Verringern Sie den Eingangspegel mit fortschreitender Abstimmung auf das Minimum (6 dB μ).
- (6) Als Ergebnis der Einstellung von Schritt 6 wird der beste Einstellpunkt für Schritt 5 etwas verschoben. Wiederholen Sie die Einstellungen für Schritt 5 und Schritt 6, bis die Verschlechterung minimal wird und der Gleichstromabgleichprüfer 0 \pm 30 mV anzeigt.
- (7) Schließen Sie die den Blindausgang des Wobbelgenerators an das lokale Oszillatorabschirmblech an. Stellen Sie den Drehkondensator so ein, daß er minimale Kapazität hat.
- (8) Stellen Sie den Kern von L151 so ein, daß Sie die in Abb. 4 gezeigte Wellenform erhalten.
- (9) Stellen Sie den Eingangspegel in Grobeinstellung auf 74 dB/m ein. Verringern Sie den Eingangspegel mit fortschreitender Einstellung auf das Minimum (52 dB/m).

PRECAUTIONS

- (1) Introduire des signaux de bas niveau (tels que des bruits sont mélangés comme indiqué à la figure 1) par le générateur de balayage. En ajustant le gain au maximum avec T101, régler la forme d'onde jusqu'à ce qu'elle apparaisse comme indiqué à la figure 1. Le côté terre de la simulation de sortie du générateur de balayage doit être connecté à la plaque de blindage de l'oscillateur local.
- (2) Introduisant des signaux de haut niveau par le générateur de balayage, ajuster la forme d'onde avec T101 jusqu'à ce qu'elle devienne comme indiqué à la figure 2.
- (3) Ajustant le T201, obtenir une courbe en S comme indiqué à la figure 3. Puis ajuster le T202 pour faire l'amplitude de la courbe en S maximale avec les points A et B symétriques au point C et la pente aussi linéaire que possible.
- (4) Le paquet de dispositif d'accord FM est aligné avant l'expédition, par suite il n'est pas nécessaire de régler la couverture et l'alignement. Si la capacitance (TC1, TC3) ou la bobine (L1 à L4) est déplacée par erreur, il est nécessaire de l'ajuster.
- (5) Mettre le niveau d'entrée à 60 dB μ par réglage grossier. Réduire le niveau d'entrée au minimum (6 dB μ) pendant le réglage.
- (6) Par suite de l'étape 6 de réglage, le meilleur point de réglage à partir de l'étape 5 sera décalé d'un bit. Répéter le réglage des étapes 5 et 6 jusqu'à ce que la détérioration devienne minimale et que l'indicateur d'équilibre c. c. indique 0 \pm 30 mV.
- (7) Connecter le côté terre de la simulation de sortie du générateur de balayage à la plaque de blindage de l'oscillateur local. Régler le condensateur variable de sorte qu'il ait la capacitance minimale.
- (8) Ajustant le noyau L151, faire une forme d'onde comme indiqué à la figure 4. Comme un filtre céramique est utilisé, les balises peuvent être hors de la position. En tel cas, négliger les balises.
- (9) Mettre le niveau d'entrée à 74 dB/m par réglage grossier. Réduire le niveau d'entrée au minimum (52 dB/m) pendant le réglage.



Fig. 1
Abb. 1

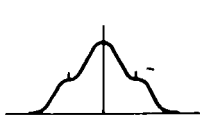

Fig. 2
Abb. 2

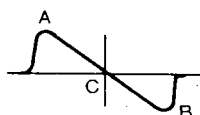

Fig. 3
Abb. 3

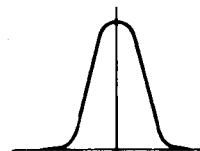

Fig. 4
Abb. 4

AM TUNER ALIGNMENT · ABGLEICH DES MW-TUNERS · REGLAGE DE TUNER AM

Condition : TUNER Function : TUNER BAND : AM Modulation : 400 Hz, 30%
 Bedingung : Tuner Funktion : Tuner Wellenbereich : MW Modulation : 400 Hz, 30%
 Condition : dispositif d'accord Bande : AM Modulation : 400 Hz, 30%

Sequence Reihenfolge Séquence	Connection Anschluß Connexion		Setting Einstellung Réglage		Adjust for Einstellen für Ajustage	
	Input Eingang Entrée	Output Ausgang Sortie	Tuning Abstimmung Syntonisation	Signal	Adjust Einstellen Ajustage	Indication Anzeige Indication
1	IF Amp. ZF-Verstärker Amp. IF	TP. 2 100 k 0.1 μ	TP. 4 100 k 0.1 μ	455 kHz	T153	Caution 7, 8 Vorsicht 7, 8 Précautions 7, 8
2	Covering Abgleich Couverture	REC OUT	600 kHz	515 kHz	T151	V max Caution 9 Vorsicht 9 Précaution 9
				1650 kHz	CT152	
3	Tracking Vorstufe Alignement	Loop antenna Rahmenantenne Antenne bouclée	1400 kHz	600 kHz	L151	V max Caution 9 Vorsicht 9 Précaution 9
				1400 kHz	CT151	

Fig. 8 FM MPX 76 kHz adjustment (Step. 7)
 Abb. 8 UKW-Dekoder 76-kHz-Abgleich (Schritt 7)
 Fig. 8 Ajustage FM MPX 76 kHz (Etape 7)

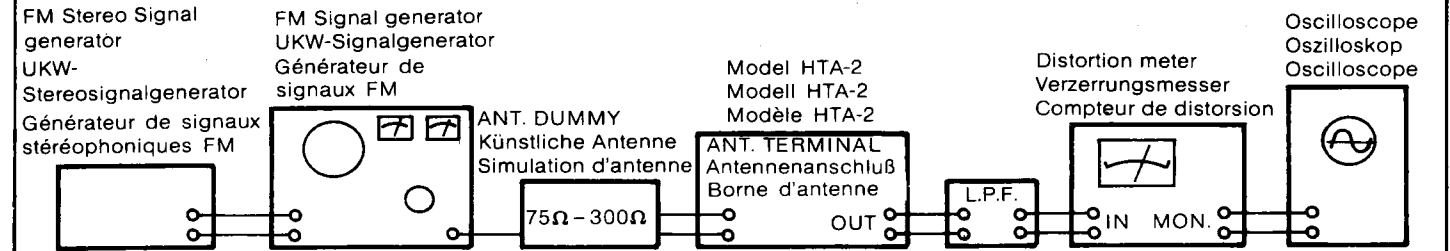
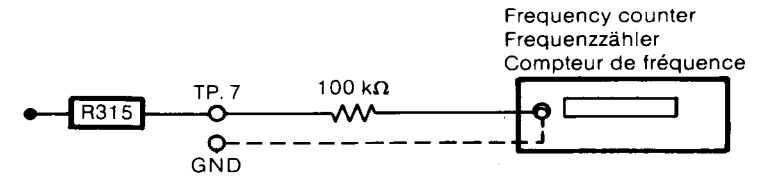
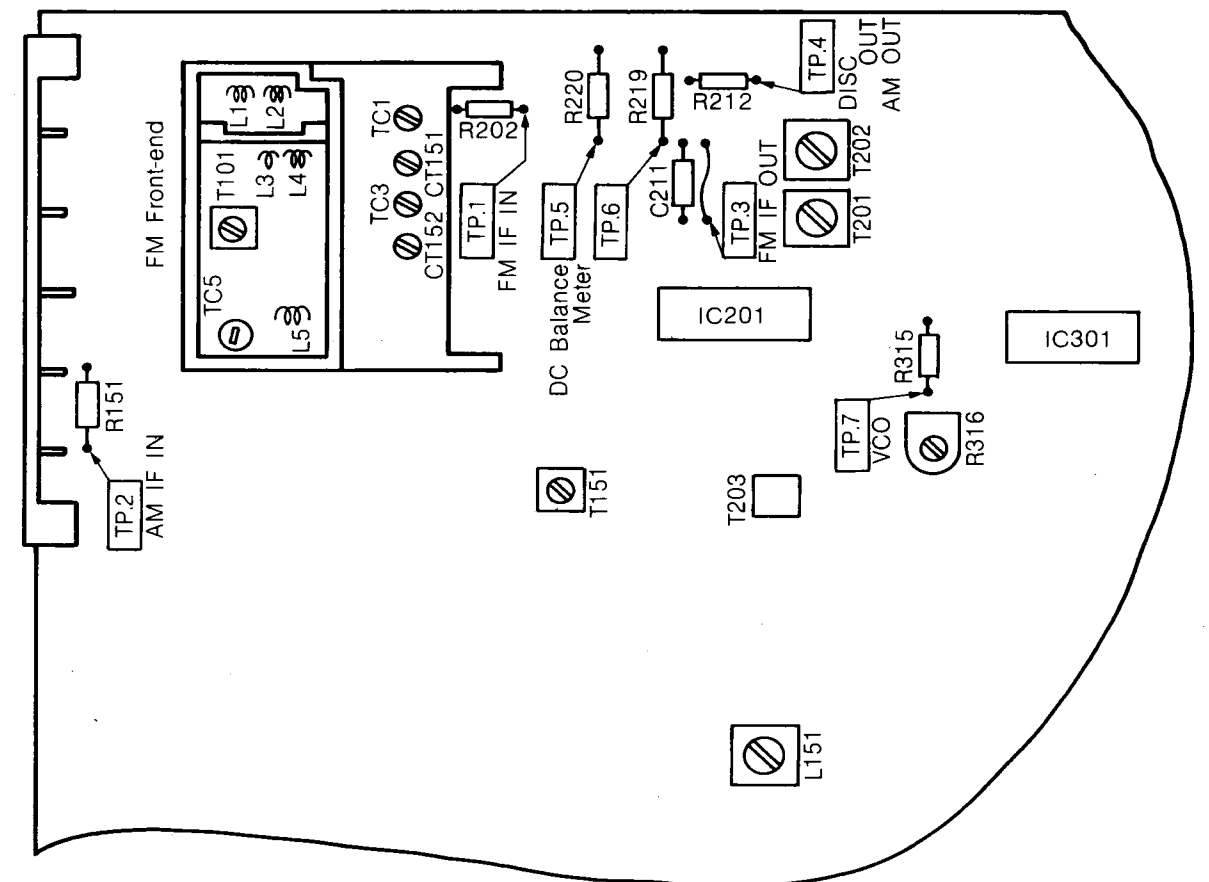
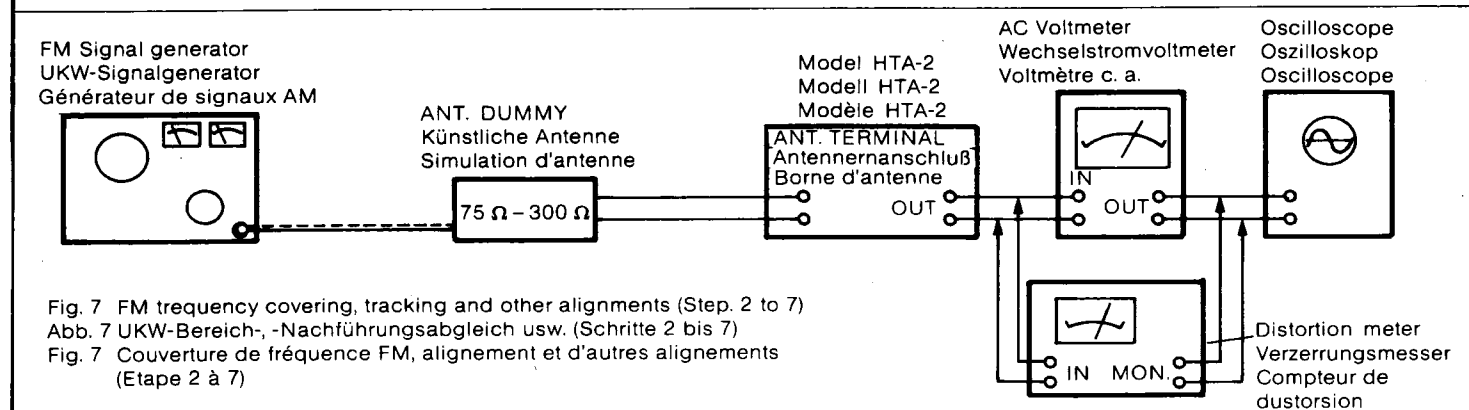
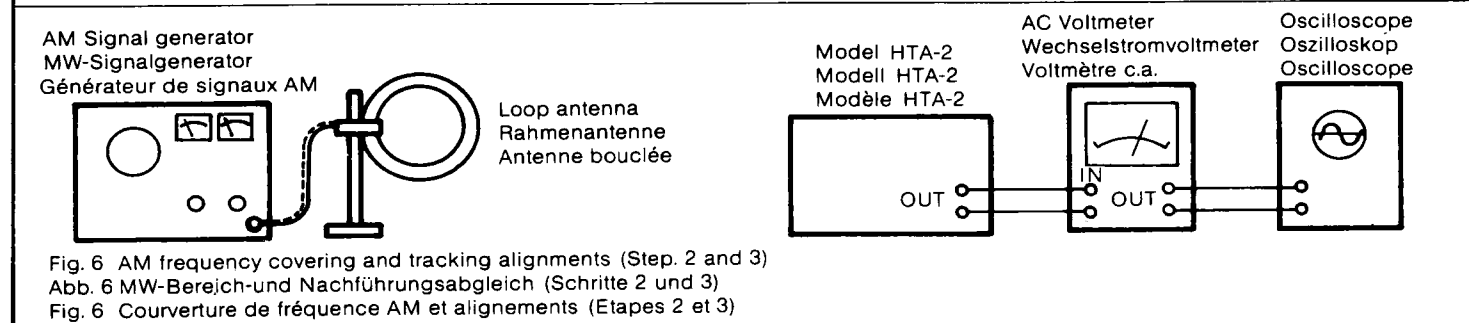
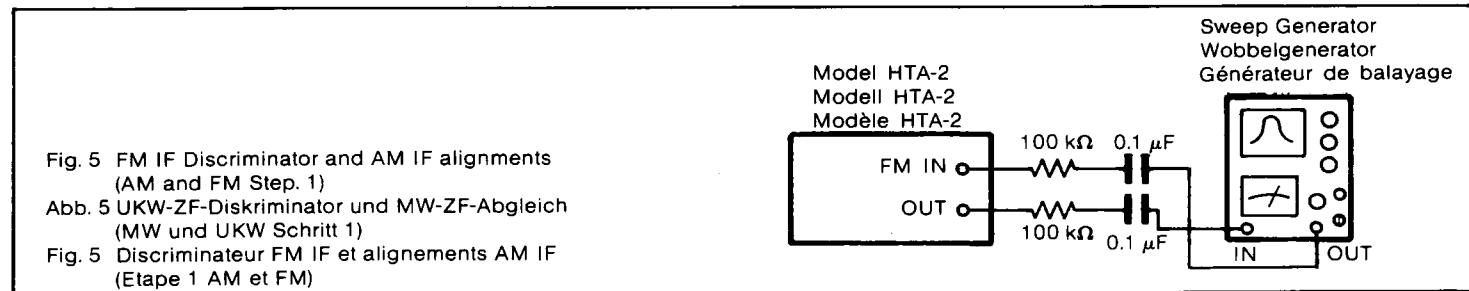

Fig. 9 Stereo Distortion adjustments (Step. 8)
 Abb. 9 Stereoverzerrungseinstellungen (Schritt 8)
 Fig. 9 Réglages de distorsion stéréophonique (Etape 8)

GENERAL ALIGNMENT INSTRUCTION · ALLGEMEINE ABGLEICHANLEITUNG · INSTRUCTION GENERALE DE REGLAGE



PRINTED WIRING BOARD · PRINTPLATTEN · PLAN DE BASE [■ :Earth, ■ :Other]

- * : Axial lead cylindrical ceramic capacitor
- * : Zylindrischer Keramikkondensator mit axialer Zuleitung
- * : Condensateur céramique cylindrique à conducteur axial

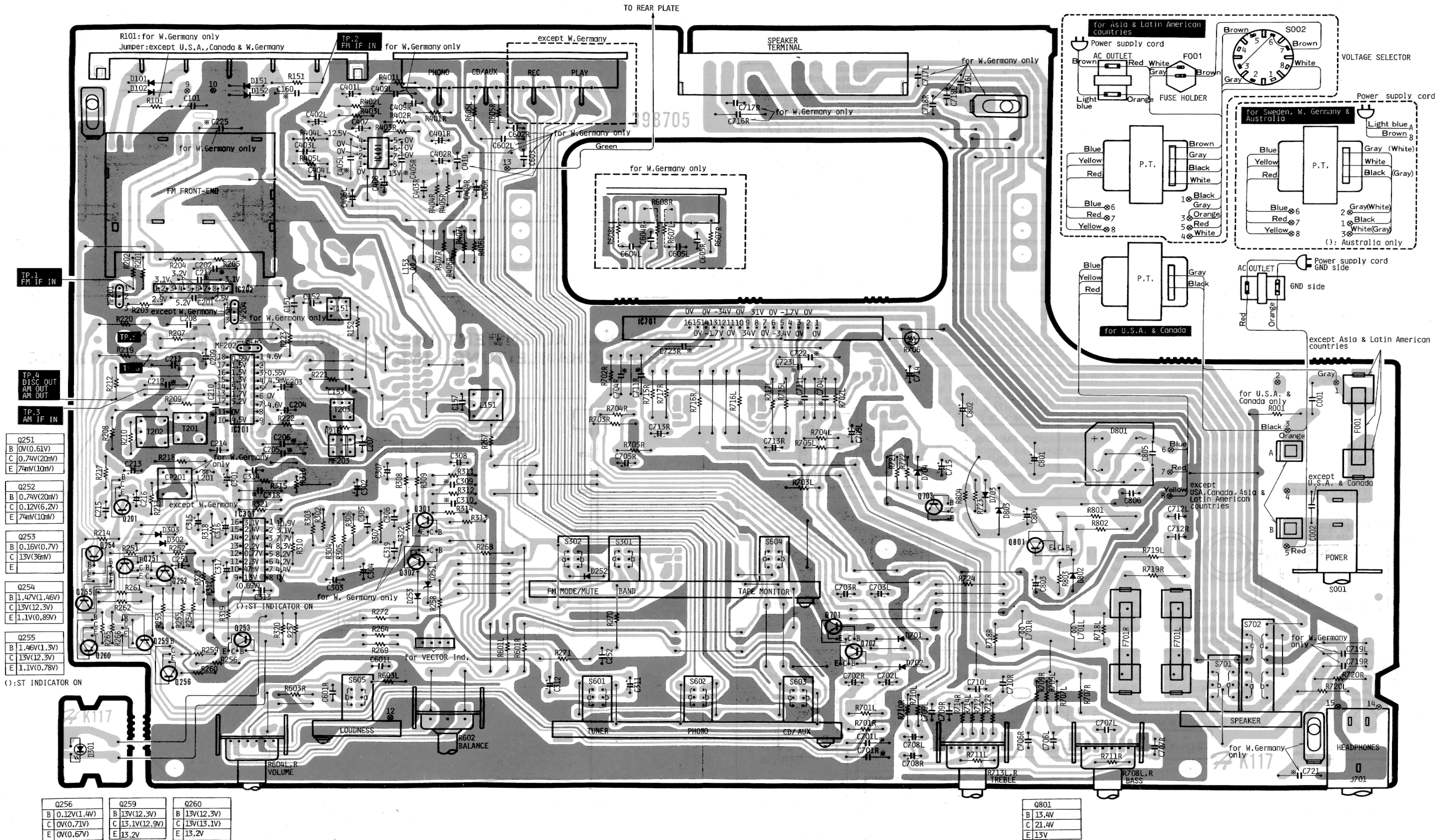

Q251
B 0V(0.61V)
C 0.74V(20mV)
E 74mV(10mV)

Q252
B 0.74V(20mV)
C 0.12V(6.2V)
E 74mV(10mV)

Q253
B 0.15V(0.7V)
C 13V(36mV)
E

Q254
B 1.47V(1.46V)
C 13V(12.3V)
E 1.1V(0.89V)

Q255
B 1.46V(1.3V)
C 13V(12.3V)
E 1.1V(0.78V)

Q256
B 0.12V(1.4V)
C 0V(0.71V)
E 0V(0.67V)

Q259
B 13V(12.3V)
C 13.1V(12.9V)
E 13.2V

Q260
B 13V(12.3V)
C 13V(13.1V)
E 13.2V

Q801
B 13.4V
C 21.4V
E 13V

CIRCUIT DIAGRAM · SCHALTPLAN · PLAN DE CIRCUIT

- * : Axial lead cylindrical ceramic capacitor
- * : Zylindrischer Keramikcondensator mit axialer Zuleitung
- * : Condensateur céramique cylindrique à conducteur axial

CAUTION
Use the electrolytic capacitors with explosion-proof valve when the diameter of them is more than 10mmφ.

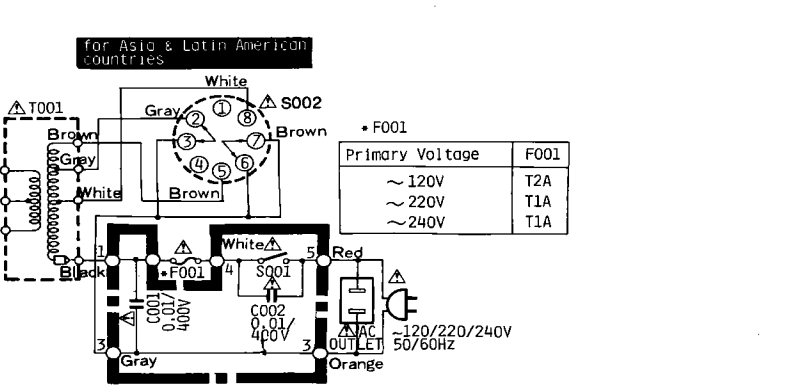
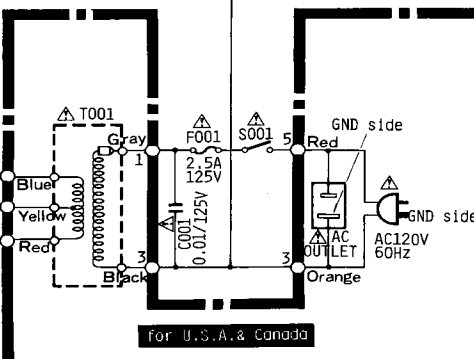
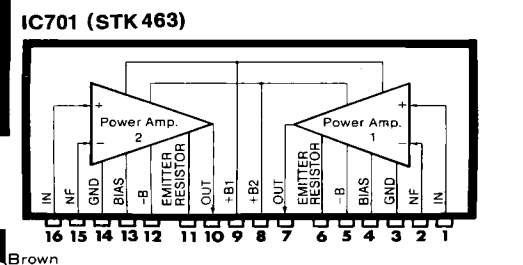
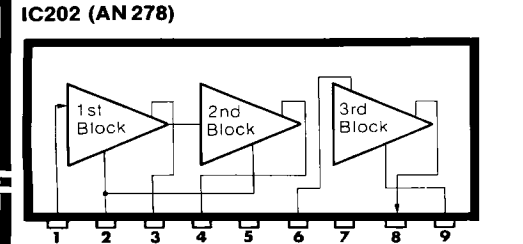
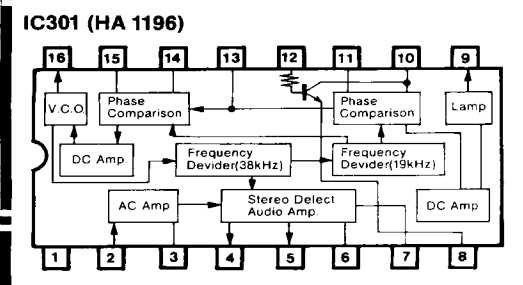
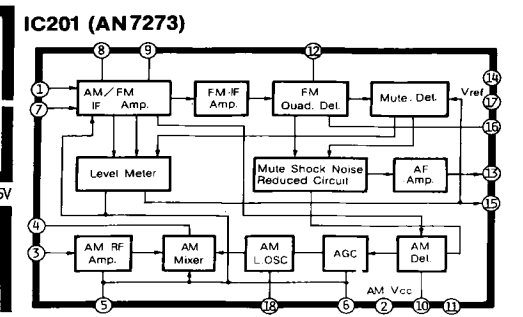
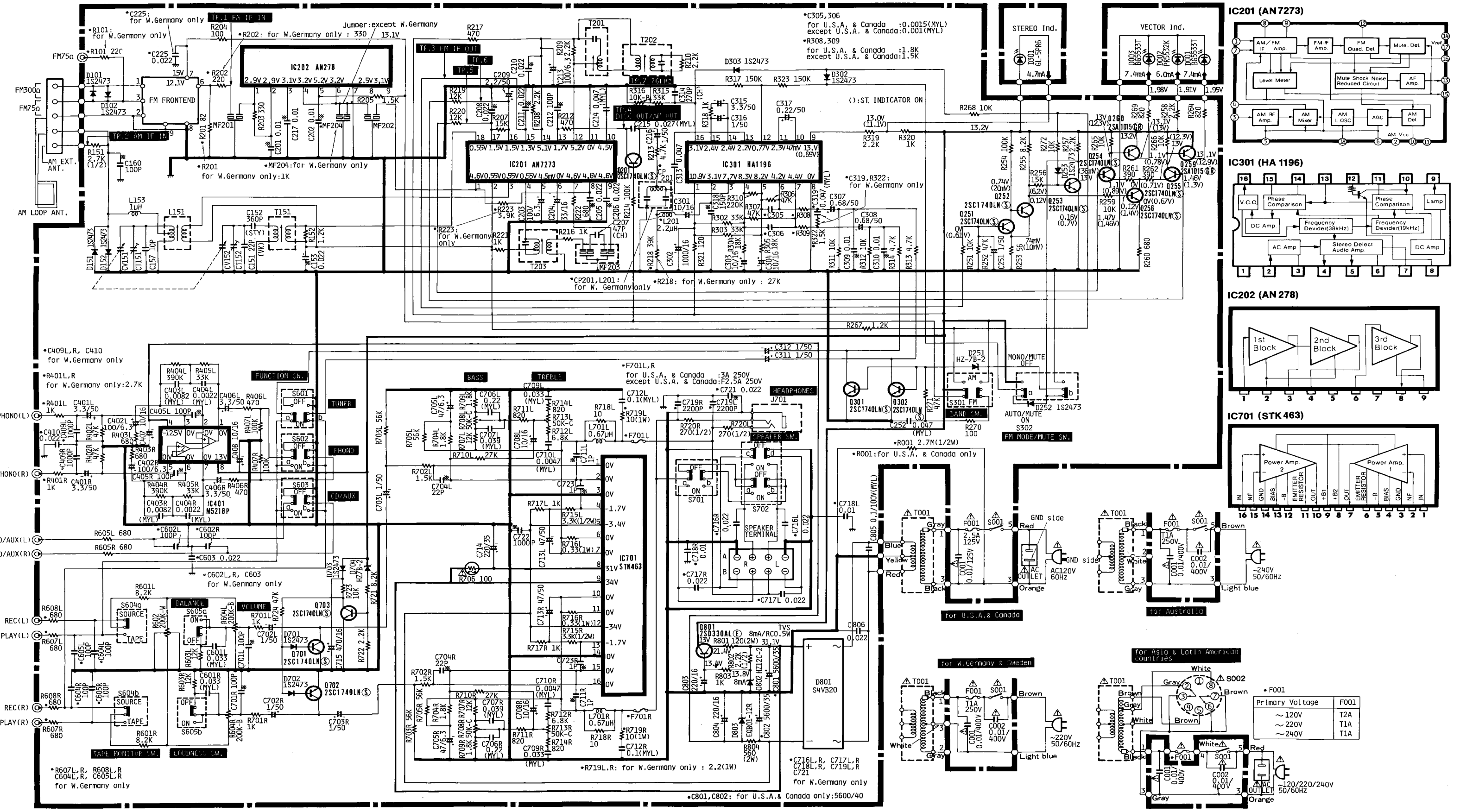

Tuner pack (except W. Germany)

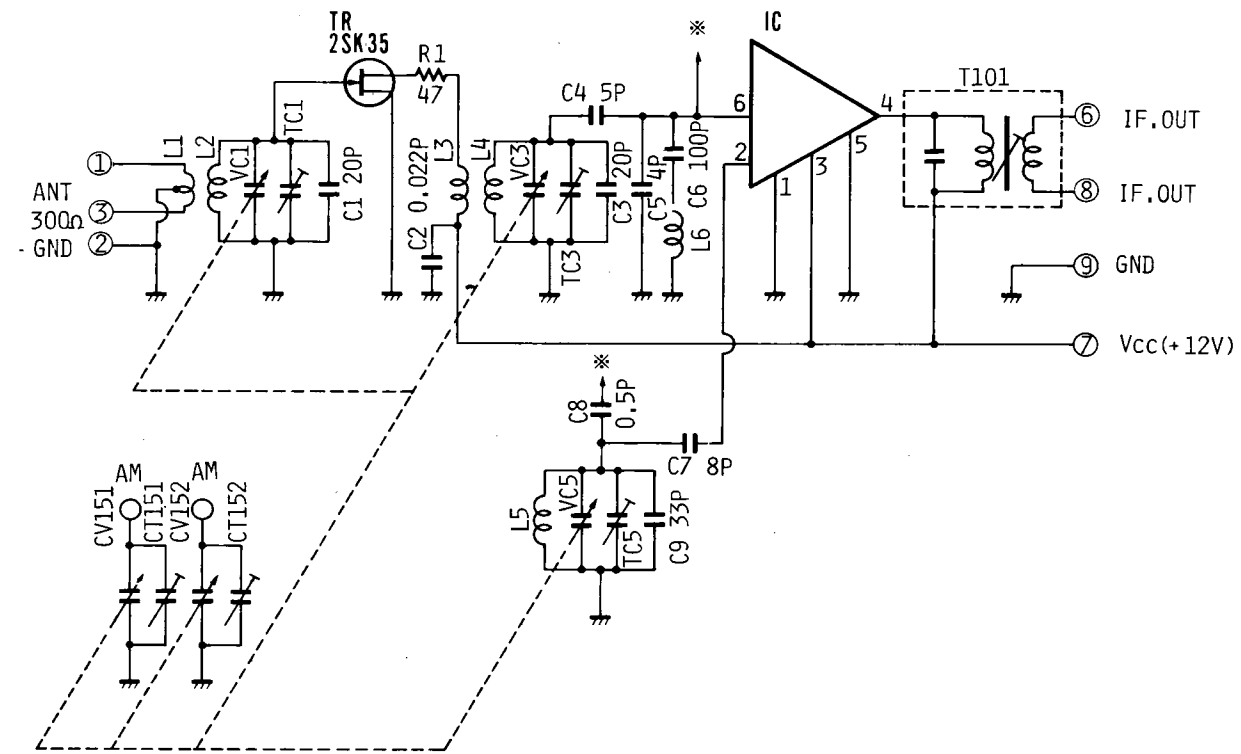

Tuner pack (for W. Germany)

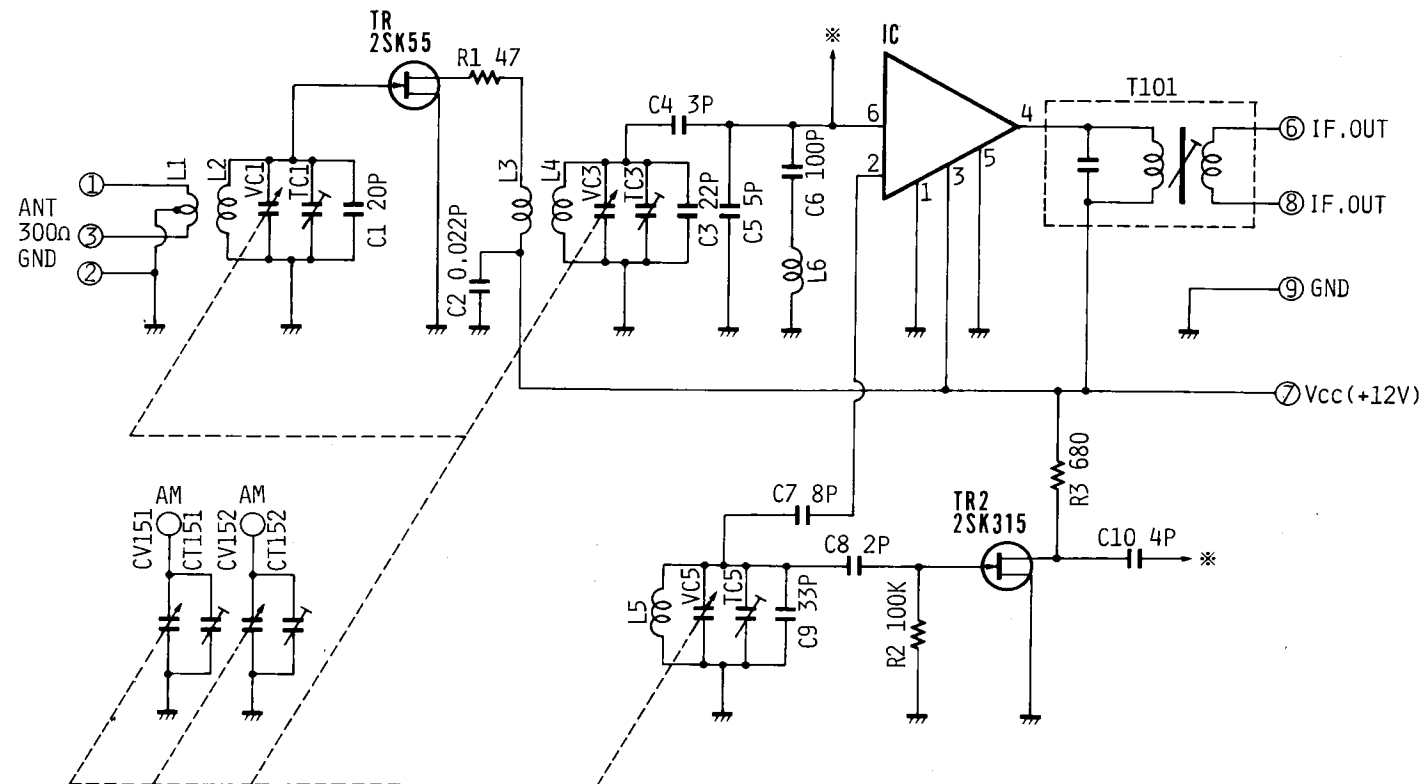

BLOCK DIAGRAM · BLOCK SCHEMA · SCHEMA

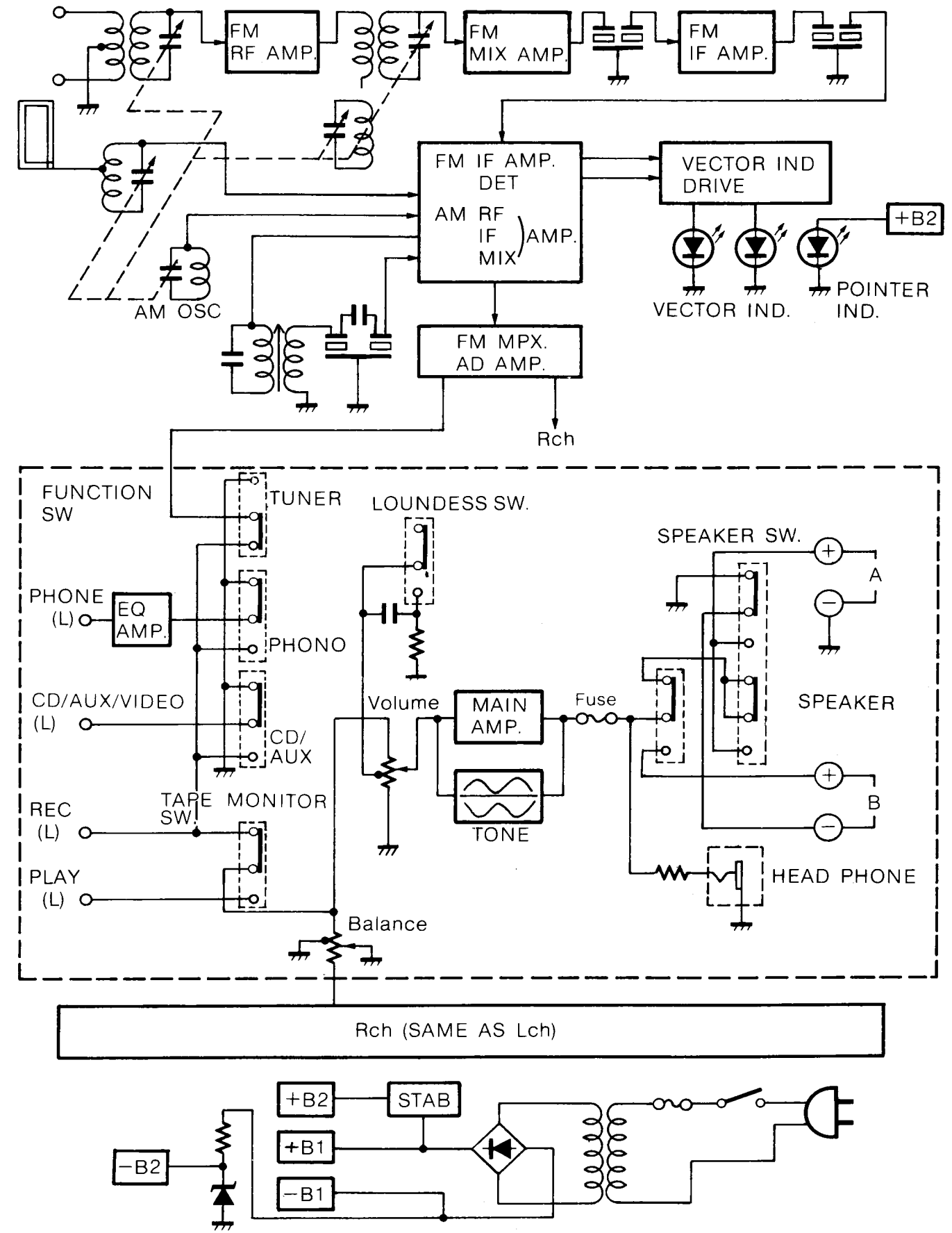

REPLACEMENT PARTS LIST · ERSATZTEILISTE · TABLEAU DES PIECE

SYMBOL No.	PART No.	DESCRIPTION			SYMBOL No.	PART No.	DESCRIPTION			
CAPASITORS										
C001	0243899	Ceramic, discal (for U.S.A. & Canada)	0.01 μ F	$\begin{matrix} +100 \\ -0 \end{matrix}$ %	125 V	C401LR	0252813	Electrolytic	3.3 μ F	50 V
C001	0243901	Ceramic, discal (except U.S.A. & Canada)	0.01 μ F	$\begin{matrix} +100 \\ -0 \end{matrix}$ %	400 V	C402LR	0252231	Electrolytic	100 μ F	6.3 V
C002	0243901	Ceramic, discal (for W. Germany)	0.01 μ F	$\begin{matrix} +100 \\ -0 \end{matrix}$ %	400 V	C403LR	0274236	Mylar, film	0.0082 μ F \pm 5%	50 V
C151	0241884	Cylindrical ceramic	22 pF	\pm 5%	50 V	C404LR	0274013	Mylar, film	0.0022 μ F \pm 10%	50 V
C152	0228324	Styrol	360 pF	\pm 5%	50 V	C405LR	0230036	Cylindrical ceramic	100 pF \pm 5%	50 V
C153	0240108	Ceramic, discal	0.022 μ F	\pm 30%	16 V	C406LR	0252813	Electrolytic	3.3 μ F	50 V
C157	0246420	Cylindrical ceramic	10 pF	\pm 0.25%	50 V	C407	0252521	Electrolytic	10 μ F	16 V
C160	0230036	Cylindrical ceramic	100 pF	\pm 5%	50 V	C408	0252521	Electrolytic	10 μ F	16 V
C201	0240106	Ceramic, discal	0.01 μ F	\pm 30%	25 V	C409R	0244161	Ceramic, discal (for W. Germany)	0.001 μ F $\begin{matrix} +80 \\ -20 \end{matrix}$ %	50 V
C202	0240106	Ceramic, discal	0.01 μ F	\pm 30%	25 V	C409L	0240020	Ceramic, discal (for W. Germany)	0.001 μ F \pm 20%	50 V
C203	0252231	Electrolytic	100 μ F		6.3 V	C410	0244173	Ceramic, discal (for W. Germany)	0.022 μ F $\begin{matrix} +80 \\ -20 \end{matrix}$ %	50 V
C204	0252523	Electrolytic	33 μ F		16 V	C601LR	0275014	Mylar, film	0.033 μ F \pm 10%	50 V
C205	0240108	Ceramic, discal	0.022 μ F	\pm 30%	16 V	C602R	0248684	Cylindrical ceramic (for W. Germany)	100 pF \pm 5%	50 V
C206	0250108	Ceramic, discal	0.022 μ F	\pm 30%	16 V	C602L	0230020	Cylindrical ceramic (for W. Germany)	100 pF \pm 5%	50 V
C207	0246456	Cylindrical ceramic	47 pF	\pm 5%	50 V	C603	0244173	Ceramic, discal (for W. Germany)	0.022 μ F $\begin{matrix} +80 \\ -20 \end{matrix}$ %	50 V
C208	0240108	Ceramic, discal	0.022 μ F	\pm 30%	16 V	C604LR	0208684	Cylindrical ceramic (for W. Germany)	100 pF \pm 5%	50 V
C209	0252812	Electrolytic	2.2 μ F		50 V	C605LR	0248684	Cylindrical ceramic (for W. Germany)	100 pF \pm 5%	50 V
C210	0240108	Ceramic, discal	0.022 μ F	\pm 30%	16 V	C701LR	0230036	Cylindrical ceramic	100 pF \pm 5%	50 V
C211	0240108	Ceramic, discal	0.022 μ F	\pm 30%	16 V	C702LR	0252811	Electrolytic	1 μ F	50 V
C212	0230036	Cylindrical ceramic	100 pF	\pm 5%	50 V	C703LR	0252811	Electrolytic	1 μ F	50 V
C213	0252231	Electrolytic	100 μ F		6.3 V	C704LR	0230020	Cylindrical ceramic	22 pF \pm 5%	50 V
C214	0275015	Mylar, film	0.047 μ F	\pm 10%	50 V	C705LR	0252225	Electrolytic	47 μ F	6.3 V
C215	0275033	Mylar, film	0.027 μ F	\pm 10%	50 V	C706LR	0276013	Mylar, film	0.22 μ F \pm 10%	50 V
C216	0252811	Electrolytic	1 μ F		50 V	C707LR	0275034	Mylar, film	0.039 μ F \pm 10%	50 V
C217	0240106	Ceramic, discal	0.01 μ F	\pm 30%	25 V	C708LR	0252521	Electrolytic	10 μ F	16 V
C225	0240108	Ceramic, discal (for W. Germany)	0.0022 μ F	\pm 30%	50 V	C709LR	0275014	Mylar, film	0.033 μ F \pm 10%	50 V
C226	0240106	Ceramic, discal (for W. Germany)	0.01 μ F	\pm 30%	25 V	C710LR	0274015	Mylar, film	0.0047 μ F \pm 10%	50 V
C251	0252811	Electrolytic	1 μ F		50 V	C711LR	0230000	Cylindrical ceramic	1 pF \pm 20%	50 V
C252	0275015	Mylar, film	0.047 μ F	\pm 10%	50 V	C712LR	0276011	Mylar, film	0.1 μ F \pm 10%	50 V
C301	0252521	Electrolytic	10 μ F		16 V	C713LR	0252825	Electrolytic	47 μ F	50 V
C302	0252541	Electrolytic	1000 μ F		16 V	C714	0252732	Electrolytic	220 μ F	35 V
C303	0252521	Electrolytic	10 μ F		16 V	C715	0252535	Electrolytic	470 μ F	16 V
C304	0252521	Electrolytic	10 μ F		16 V	C716R	0240108	Ceramic, discal (for W. Germany)	0.022 μ F \pm 30%	16 V
C305	0274012	Mylar, film (for U.S.A. & Canada)	0.0015 μ F	\pm 10%	50 V	C716L	0244173	Ceramic, discal (for W. Germany)	0.022 μ F $\begin{matrix} +80 \\ -20 \end{matrix}$ %	50 V
C305	0274011	Mylar film (except U.S.A. & Canada)	0.001 μ F	\pm 10%	50 V	C717LR	0244173	Ceramic, discal (for W. Germany)	0.022 μ F $\begin{matrix} +80 \\ -20 \end{matrix}$ %	50 V
C306	0274012	Mylar, film (for U.S.A. & Canada)	0.0015 μ F	\pm 10%	50 V	C718LR	0244171	Ceramic, discal (for W. Germany)	0.01 μ F $\begin{matrix} +80 \\ -20 \end{matrix}$ %	50 V
C306	0274011	Mylar film (except U.S.A. & Canada)	0.001 μ F	\pm 10%	50 V	C719LR	0240102	Ceramic, discal (for W. Germany)	0.0022 μ F \pm 30%	25 V
C307	0252876	Electrolytic	0.68 μ F		50 V	C721	0240108	Ceramic, discal (for W. Germany)	0.0022 μ F \pm 30%	50 V
C308	0252876	Electrolytic	0.68 μ F		50 V	C722	0240020	Ceramic, discal	0.001 μ F \pm 20%	50 V
C309	0240106	Ceramic, discal	0.01 μ F	\pm 30%	25 V	C723LR	0230000	Cylindrical ceramic	1 pF \pm 20%	50 V
C310	0240106	Ceramic, discal	0.01 μ F	\pm 30%	25 V	C801	0259923	Electrolytic (for U.S.A. & Canada)	5600 pF	40 V
C311	0252811	Electrolytic	1 μ F		50 V	C801	0259998	Electrolytic (except U.S.A. & Canada)	5600 μ F	35 V
C312	0252811	Electrolytic	1 μ F		50 V	C802	0259933	Electrolytic (for U.S.A. & Canada)	5600 μ F	40 V
C313	0244185	Ceramic, discal	0.047 μ F	$\begin{matrix} +80 \\ -20 \end{matrix}$ %	50 V					
C314	0246470	Cylindrical ceramic	270 pF	\pm 5%	50 V					
C315	0252813	Electrolytic	3.3 μ F		50 V					
C316	0252811	Electrolytic	1 μ F		50 V					
C317	0252802	Electrolytic	0.22 μ F		50 V					
C318	0240002	Ceramic, discal	150 pF	\pm 10%	50 V					
C319	0275015	Mylar, film (for W. Germany)	0.047 μ F	\pm 10%	50 V					

SYMBOL No.	PART No.	DESCRIPTION			SYMBOL No.	PART No.	DESCRIPTION				
C802	0259998	Electrolytic (except U.S.A. & Canada)	5600 μ F	35 V	R265	0129631	Carbon film	10 k Ω	\pm 5%	SRD1/4P	
C803	0252532	Electrolytic	220 μ F	16 V	R266	0129631	Carbon film	10 k Ω	\pm 5%	SRD1/4P	
C804	0252532	Electrolytic	220 μ F	16 V	R267	0129603	Carbon film	1.2 k Ω	\pm 5%	SRD1/4P	
C805	0276511	Mylar, film	0.1 μ F	\pm 10%	R268	0129631	Carbon film	10 k Ω	\pm 5%	SRD1/4P	
C806	0244173	Ceramic, discal	0.022 μ F	$\begin{matrix} +80 \\ -20 \end{matrix}$ %	R269	0129583	Carbon film	820 Ω	\pm 5%	SRD1/4P	
RESISTORS					R270	0129561	Carbon film	100 Ω	\pm 5%	SRD1/4P	
R001	0139005	Composition (for U.S.A. & Canada)	2700 k Ω	\pm 10%	RC1/2GF	R271	0129647	Carbon film	47 k Ω	\pm 5%	SRD1/4P
R101	0129569	Carbon film (for W. Germany)	220 Ω	\pm 5%	SRD1/4P	R272	0129631	Carbon film	10 k Ω	\pm 5%	SRD1/4P
R151	0134378	Composition	2.7 k Ω	\pm 10%	RC1/2GF	R302	0129643	Carbon film	33 k Ω	\pm 5%	SRD1/4P
R152	0129603	Carbon film	1.2 k Ω	\pm 5%	SRD1/4P	R303	0129643	Carbon film	33 k Ω	\pm 5%	SRD1/4P
R201	0129553	Carbon film (except W. Germany)	82 Ω	\pm 5%	SRD1/4P	R304	0239637	Carbon film	18 k Ω	\pm 5%	SRD1/4P
R201	0129601	Carbon film (for W. Germany)	1 k Ω	\pm 5%	SRD1/4P	R305	0129637	Carbon film	18 k Ω	\pm 5%	SRD1/4P
R202	0129569	Carbon film (except W. Germany)	220 Ω	\pm 5%	SRD1/4P	R306	0129647	Carbon film	47 k Ω	\pm 5%	SRD1/4P
R202	0129573	Carbon film (for W. Germany)	330 Ω	\pm 5%	SRD1/4P	R307	0129647	Carbon film	47 k Ω	\pm 5%	SRD1/4P
R203	0129573	Carbon film	330 Ω	\pm 5%	SRD1/4P	R308	0129607	Carbon film	1.8 k Ω	\pm 5%	SRD1/4P
R204	0129561	Carbon film	100 Ω	\pm 5%	SRD1/4P	R309	0129607	Carbon film	1.8 k Ω	\pm 5%	SRD1/4P
R205	0129605	Carbon film	1.5 k Ω	\pm 5%	SRD1/4P	R310	0129669	Carbon film	220 k Ω	\pm 5%	SRD1/4P
R207	0129635	Carbon film	15 k Ω	\pm 5%	SRD1/4P	R311	0129631	Carbon film	10 k Ω	\pm 5%	SRD1/4P
R208	0129609	Carbon film	2.2 k Ω	\pm 5%	SRD1/4P	R312	0129631	Carbon film	10 k Ω	\pm 5%	SRD1/4P
R209	0129609	Carbon film	2.2 k Ω	\pm 5%	SRD1/4P	R313	0129617	Carbon film	4.7 k Ω	\pm 5%	SRD1/4P
R210	0129609	Carbon film	2.2 k Ω	\pm 5%	SRD1/4P	R314	0129617	Carbon film	4.7 k Ω	\pm 5%	SRD1/4P
R212	0129577	Carbon film	470 Ω	\pm 5%	SRD1/4P	R315	0129643	Carbon film	33 k Ω	\pm 5%	SRD1/4P
R213	0129617	Carbon film	4.7 k Ω	\pm 5%	SRD1/4P	R317	0129665	Carbon film	150 k Ω	\pm 5%	SRD1/4P
R214	0129661	Carbon film	100 k Ω	\pm 5%	SRD1/4P	R318	0129601	Carbon film	1 k Ω	\pm 5%	SRD1/4P
R216	0129601	Carbon film	1 k Ω	\pm 5%	SRD1/4P	R319	0129609	Carbon film	2.2 k Ω	\pm 5%	SRD1/4P
R217	0129577	Carbon film	470 Ω	\pm 5%	SRD1/4P	R320	0129601	Carbon film	1 k Ω	\pm 5%	SRD1/4P
R218	0129645	Carbon film (except W. Germany)	39 k Ω	\pm 5%	SRD1/4P	R321	0123622	Carbon film	120 Ω	\pm 5%	SRD1/4P
R218	0129641	Carbon film (for W. Germany)	27 k Ω	\pm 5%	SRD1/4P	R322	0129605	Carbon film (for W. Germany)	1.5 k Ω	\pm 5%	SRD1/4P
R219	0129633	Carbon film	12 k Ω	\pm 5%	SRD1/4P	R323	0129665	Carbon film	150 k Ω	\pm 5%	SRD1/4P
R220	0129633	Carbon film	12 k Ω	\pm 5%	SRD1/4P	R401LR	0129601	Carbon film (except W. Germany)	1 k Ω	\pm 5%	SRD1/4P
R221	0129601	Carbon film	1 k Ω	\pm 5%	SRD1/4P	R401LR	0129611	Carbon film (for W. Germany)	2.7 k Ω	\pm 5%	SRD1/4P
R222	0129581	Carbon film	680 Ω	\pm 5%	SRD1/4P	R402LR	0129647	Carbon film	47 k Ω	\pm 5%	SRD1/4P
R223	0129615	Carbon film (for W. Germany)	3.9 k Ω	\pm 5%	SRD1/4P	R403LR	0129581	Carbon film	680 Ω	\pm 5%	SRD1/4P
R251	0129631	Carbon film	10 k Ω	\pm 5%	SRD1/4P	R404LR	0129675	Carbon film	390 k Ω	\pm 5%	SRD1/4P
R252	0129647	Carbon film	47 k Ω	\pm 5%	SRD1/4P	R405LR	0129643	Carbon film	33 k Ω	\pm 5%	SRD1/4P
R253	0129549	Carbon film	56 Ω	\pm 5%	SRD1/4P	R406LR	0129577	Carbon film	470 Ω	\pm 5%	SRD1/4P
R254	0129661	Carbon film	100 k Ω	\pm 5%	SRD1/4P	R407LR	0129661	Carbon film	100 k Ω	\pm 5%	SRD1/4P
R255	0129623	Carbon film	8.2 k Ω	\pm 5%	SRD1/4P	R601LR	0129623	Carbon film	8.2 k Ω	\pm 5%	SRD1/4P
R256	0129635	Carbon film	15 k Ω	\pm 5%	SRD1/4P	R603LR	0129633	Carbon film	12 k Ω	\pm 5%	SRD1/4P
R257	0129609	Carbon film	2.2 k Ω	\pm 5%	SRD1/4P	R605LR	0129581	Carbon film	680 Ω	\pm 5%	SRD1/4P
R258	0129609	Carbon film	2.2 k Ω	\pm 5%	SRD1/4P	R607LR	0129581	Carbon film (for W. Germany)	680 Ω	\pm 5%	SRD1/4P
R259	0129631	Carbon film	10 k Ω	\pm 5%	SRD1/4P	R608LR	0129581	Carbon film (for W. Germany)	680 Ω	\pm 5%	SRD1/4P
R260	0129581	Carbon film	680 Ω	\pm 5%	SRD1/4P	R701LR	0129601	Carbon film	1 k Ω	\pm 5%	SRD1/4P
R261	0129575	Carbon film	390 Ω	\pm 5%	SRD1/4P	R702LR	0129605	Carbon film	1.5 k Ω	\pm 5%	SRD1/4P
R262	0129575	Carbon film	390 Ω	\pm 5%	SRD1/4P	R703LR	0129649	Carbon film	56 k Ω	\pm 5%	SRD1/4P
R264	0129583	Carbon film	820 Ω	\pm 5%	SRD1/4P	R704LR	0129607	Carbon film	1.8 k Ω	\pm 5%	SRD1/4P
						R705LR	0129649	Carbon film	56 k Ω	\pm 5%	SRD1/4P
						Δ R706	0110621	Metal (Fuse resistor)	100 Ω	\pm 5%	RN1/4B
						R707LR	0129633	Carbon film	12 k Ω	\pm 5%	SRD1/4P

SYMBOL No.	PART No.	DESCRIPTION			
R709LR	0129607	Carbon film	1.8 kΩ	±5%	SRD1/4P
R710LR	0129641	Carbon film	27 kΩ	±5%	SRD1/4P
R711LR	0129583	Carbon film	820 Ω	±5%	SRD1/4P
R712LR	0129621	Carbon film	6.8 kΩ	±5%	SRD1/4P
R714LR	0129583	Carbon film	820 Ω	±5%	SRD1/4P
R715LR	0134379	Composition	3.3 kΩ	±10%	RC1/2GF
R716LR	0119015	Metal	0.33 Ω	±10%	RN1B
R717LR	0129601	Carbon film	1 kΩ	±5%	SRD1/4P
R718LR	0129531	Carbon film	10 Ω	±5%	SRD1/4P
R719LR	0119041	Metal (except W. Germany)	10 Ω	±10%	RN1B
R719LR	0119025	Metal (for W. Germany)	2.2 Ω	±5%	RN1B
R720LR	0134366	Composition	270 Ω	±10%	RC1/2GF
R721	0129623	Carbon film	8.2 kΩ	±5%	SRD1/4P
R722	0129609	Carbon film	2.2 kΩ	±5%	SRD1/4P
R723	0129631	Carbon film	10 kΩ	±5%	SRD1/4P
R724	0129647	Carbon film	47 Ω	±5%	SRD1/4P
R801	0119522	Metal oxide	120 Ω	±10%	RS2B
R802	0134377	Composition	2.2 kΩ	±10%	RC1/2GF
R803	0129601	Carbon film	1 kΩ	±5%	SRD1/4P
R804	0119530	Metal oxide	560 Ω	±10%	RS2B
ICs & TRANSISTORS					
IC201	2387321	AN7273			
IC202	2368431	AN278			
IC301	2367271	HA1196			
IC401	2387301	M5218P			
IC701	2368842	STK463 - B			
Q201	2328652	2SC1740LN (S)			
Q251	2328652	2SC1740LN (S)			
Q256	2328652	2SC1740LN (S)			
Q259	2329183	2SA1015 (GR)			
Q260	2329183	2SA1015 (GR)			
Q301	2328652	2SC1740LN (S)			
Q302	2328652	2SC1740LN (S)			
Q701	2328652	2SC1740LN (S)			
Q703	2328652	2SC1740LN (S)			
Q801	2317738	2SD330 (E)			
DIODES					
D101	2337601	1S2473			
D102	2337601	1S2473			
D151	2337601	1S2473			
D152	2337601	1S2473			

SYMBOL No.	PART No.	DESCRIPTION
D251	2337545	HZ7B - 2
D252	2337601	1S2473
D253	2337601	1S2473
D301	2337751	GL - 5PR6
D302	2337601	1S2473
D303	2337601	1S2473
D701	2337601	1S2473
D703	2337601	1S2473
D704	2337545	HZ7B - 2
D801	2337461	S4VB20
D802	2337568	HZ12C - 2
D803	2337783	EQB01 - 12R
VARIABLE RESISTORS		
R316	0150958	10 kΩ - (B)
R602	0158741	200 kΩ - (W) (BALANCE)
R604LR	0158731	200 kΩ - (B) (VOLUME)
R708LR	0158732	50 kΩ - (C) (BASS)
R713LR	0158732	50 kΩ - (C) (TREBLE)
COILS & TRANSFORMERS		
L151	2136501	MW Antenna coil
L153	2227351	Choke coil - 1 μH
L201	2227394	Choke coil - 2.2 μH (for W. Germany)
L701LR	2227361	Audio trap coil - 0.67 μH
T151	2136491	MW OSC coil
T201	2155171	FM discri. coil
T202	2155172	FM discri. coil
T203	2154493	AM IF transformer
MISCELLANEOUS		
CP201	2134931	Anti - birdie filter (for W. Germany)
MF201	2134981	FM ceramic filter (for U.S.A. & Canada)
MF202	2135001	FM ceramic filter (except U.S.A. & Canada)
MF203	2155152	AM ceramic filter
MF204	2135001	FM ceramic filter (for W. Germany)
ΔS001	2639869	Switch - push SW. (POWER)
ΔS002	2618051	Voltage selector SW. (for Asia & Latin American countries, etc.)
S301	2639780	Switch - push SW. (BAND, FM MODE, TAPE MONITOR)
S302		
S604		
S601	2639788	Switch - push SW. (FUNCTION)
S603	2639788	Switch - push SW. (FUNCTION)
S605	2639786	Switch - push SW. (LOUDNESS)
S701	2638620	Switch - push SW. (SPEAKER)
S702	2638620	Switch - push SW. (SPEAKER)
	2688203	5P Antenna terminal (for U.S.A. & Canada)
	2688204	5P Antenna terminal (except U.S.A. & Canada)
	2688281	8P Push terminal

SYMBOL No.	PART No.	DESCRIPTION	SYMBOL No.	PART No.	DESCRIPTION
	2678345	8P US pin jack	△	2248251	Power transformer (for U.S.A. & Canada)
	2568391	Din socket (for W. Germany)	△	2247542	Power transformer (for W. Germany, Sweden & Australia)
	2677911	Din socket (except U.S.A., Canada, Asia & Latin American countries, etc.)	△	2247543	Power transformer (for W. Germany, Asia & Latin American countries, etc.)
	2677649	Headphone jack		4586561	2.3φ × 4 screw (for P.W.B. holder fixing others)
△ F701LR	2668633	TSL pin post (4P)		4567411	3φ × 6 CT bind screw (for P.W.B. holder fixing others)
△ F701LR	2727223	Fuse - 3A 250V SS2 (for U.S.A. & Canada)		4567412	3φ × 8 DT bind screw (for leg fixing)
△ F001	2727335	Fuse - 2.5A 250V (except U.S.A. & Canada)		4567432	3φ × 8 DT bind screw (for rear plate)
△ F001	2727564	Fuse - 2.5A 125V ST6 (for U.S.A. & Canada)		4568812	3φ × 8 DT screw (for front panel)
△ F001	2727191	Fuse - T1A 250V		4784106	3φ × 10 bind tapping screw (for rear terminal fixing)
for FINAL ASSEMBLY				4567454	3φ × 12 DT bind screw (for P.W.B. holder fixing)
	4449432	Cover (Metalic silver)		4567422	4φ × 10 DT bind screw (for P. trans. fixing)
	3298951	Knob (BALANCE)		4449521	Rear plate (for U.S.A.)
	3297101	Knob (BASS, TREBLE)		4449522	Rear plate (for Canada)
	3297111	Knob ass'y (VOLUME)		4449523	Rear plate (for W. Germany)
	3297112	Knob ass'y (TUNING)		4449524	Rear plate (for Sweden)
	4567463	4φ × 10 DT bind screw (for cover fixing)	△	4449525	Rear plate (for W. Germany, Asia & Latin American countries, etc.)
for DIAL MECHANISM ASSEMBLY			△	0043793	Bushing (for U.S.A.)
	3957981	Front panel	△	3913006	Bushing (for Canada)
	3957601	Blind		4575661	Earth screw
	3958001	Rivet	△	4408861	Washer
	3957645	Dial scale	△	2657721	AC outlet (for W. Germany, Asia & Latin American countries etc.)
	3297371	Power button ass'y	△	2658372	AC outlet (for Canada)
	3296522	Push button (SP. LOUDNESS)	△	2702331	Power supply cord (for U.S.A.)
	3297652	Knob (TAPE MONITOR)	△	2700122	Power supply cord (for Canada)
	3297162	Knob (BAND, FM MODE)	△	2748752	Power supply cord (except U.S.A. Canada & Australia)
	3297181	Knob ass'y (PHONO)	△	2749622	Power supply cord (for Australia)
	3297182	Knob ass'y (TUNER)	△	2757522	FM antenna (except W. Germany)
	3297183	Knob ass'y (CD/AUX)	△	2727671	Fuse holder (for W. Germany, Aisa & Latin American countries, etc.)
	3387621	Dial pointer ass'y		4578293	2.6φ × 6 DT bind screw (for W. Germany)
	3356264	Tuning ass'y		4567451	3φ × 6 DT bind screw (for W. Germany)
	3928651	Leg	△	2658361	E socket adaptor (for Asia & Latin American countries, etc.)
	2757573	AM loop antenna			

FRONT AND REAR PANEL · VORDERE UND HINTERE BEDIENUNGSTAFEL · PANNEAUX AVANT ET ARRIERE

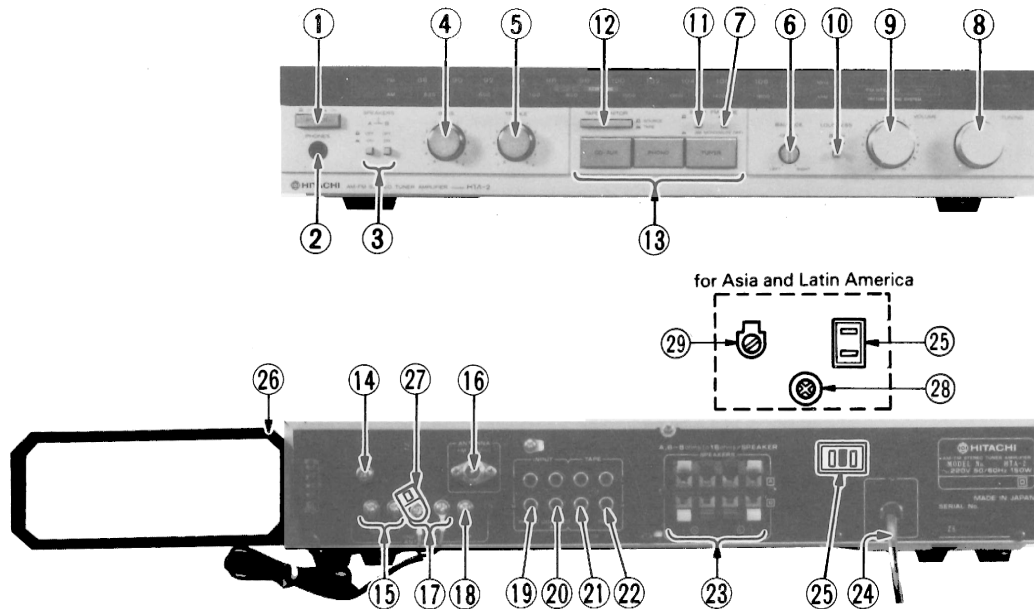

- ① POWER switch
- ② PHONES jack
- ③ SPEAKERS switch
- ④ BASS control
- ⑤ TREBLE control
- ⑥ BALANCE control
- ⑦ FM MODE switch
- ⑧ TUNING knob
- ⑨ VOLUME control
- ⑩ LOUDNESS switch
- ⑪ BAND switch
- ⑫ TAPE MONITOR switch
- ⑬ Function switches
- ⑭ Ground terminal (GND)
- ⑮ FM ANTENNA terminals (300 ohms)
- ⑯ FM ANTENNA terminal (75 ohms)
- ⑰ AM LOOP ANTENNA terminals
- ⑱ AM ANTENNA terminal (EXTERNAL)
- ⑲ PHONO INPUT jacks
- ⑳ CD/VIDEO/AUX INPUT jacks
- ㉑ TAPE REC jacks
- ㉒ TAPE PLAY jacks
- ㉓ SPEAKERS terminals
- ㉔ Power supply cord
- ㉕ AC outlet (for U.S.A., Canada, Asia & Latin American countries)
- ㉖ AM LOOP ANTENNA
- ㉗ FM ANTENNA terminal (75 ohms DIN)
- ㉘ Fuse holder (for Asia and Latin America countries)
- ㉙ Voltage selector (for Asia and Latin American countries)

- ① Netzschalter (POWER)
- ② Kopfhörerbuchse (PHONES)
- ③ Lautsprecherschalter (SPEAKERS)
- ④ Tiefenregler (BASS)
- ⑤ Höhenregler (TREBLE)
- ⑥ Balanceregler (BALANCE)
- ⑦ UKW-Betriebsartenschalter (FM MODE)
- ⑧ Abstimmregler (TUNING)
- ⑨ Lautstärkereglter (VOLUME)
- ⑩ Schalter für physiologische Lautstärkekorrektur (LOUDNESS)
- ⑪ Wellenbereichswähler (BAND)
- ⑫ Bandmonitorschalter (TAPE MONITOR)
- ⑬ Funktionsschalter
- ⑭ Masseklemme (GND)
- ⑮ UKW-Antennenanschlüsse (FM ANTENNA) (300 Ohm)
- ⑯ UKW-75-Ohm-Antennenbuchse (FM ANTENNA) (75 Ohm)
- ⑰ MW-Rahmenantennenbuchsen (AM LOOP ANTENNA)
- ⑱ MW-Außenantennenbuchse (AM ANTENNA)
- ⑲ Plattenspieler-Eingangsbuchsen (PHONO INPUT)
- ⑳ Kompaktplattenspieler-/Video-/Reserve-Eingangsbuchsen (CD/VIDEO/AUX INPUT)
- ㉑ Bandaufnahmebuchsen (TAPE REC)
- ㉒ Bandwiedergabebuchsen (TAPE PLAY)
- ㉓ Lautsprecheranschlüsse (SPEAKERS)
- ㉔ Netzkabel
- ㉕ Kaltgeräte-Steckdose (für USA, Kanada, Asien und Lateinamerika)
- ㉖ MW-Rahmenantenne
- ㉗ UKW-75-Ohm-Antennenbuchse (FM ANTENNA) (75 Ohm DIN) (für die Bundesrepublik Deutschland)
- ㉘ Halter für Sicherung (FUSE) (für Asien und Lateinamerika)
- ㉙ Netzspannungswähler (VOLTAGE SELECTOR) (für Asien und Lateinamerika)

- ① Interrupteur d'alimentation (POWER)
- ② Prise de casque (PHONES)
- ③ Interrupteur d'enceintes (SPEAKERS)
- ④ Commande de graves (BASS)
- ⑤ Commande des aigues (TREBLE)
- ⑥ Commande d'équilibrage (BALANCE)
- ⑦ Commutateur de mode FM (FM MODE)
- ⑧ Bouton d'accord (TUNING)
- ⑨ Commande de VOLUME
- ⑩ Commutateur de correction physiologique (LOUDNESS)
- ⑪ Commutateur de bande (BAND)
- ⑫ Commutateurs de contrôle de bande (TAPE MONITOR)
- ⑬ Commutateurs de fonction
- ⑭ Prise de terre (GND)
- ⑮ Bornes d'antenne FM (300 ohms)
- ⑯ Bornes d'antenne FM (75 ohms)
- ⑰ Bornes d'antenne AM (AM LOOP)
- ⑱ Borne d'antenne AM extérieure (EXTERNAL)
- ⑲ Prises d'entrée phono (PHONO INPUT)
- ⑳ Prises d'entrée CD/VIDEO/AUX
- ㉑ Prises TAPE REC
- ㉒ Prises TAPE PLAY
- ㉓ Bornes d'enceintes (SPEAKERS)
- ㉔ Cordon d'alimentation
- ㉕ Sortie C.A. (pour les E.U., le Canada, l'Asie et l'Amérique latine)
- ㉖ Antenne-cadre AM
- ㉗ Borne d'antenne FM (FM ANTENNA) (75 ohms DIN) (pour l'Allemagne de l'ouest)
- ㉘ Support de fusible (FUSE) (pour l'Asie et les pays d'Amérique Latine)
- ㉙ Sélecteur de tension (VOLTAGE SELECTOR) (pour l'Asie et les pays d'Amérique Latine)



HITACHI SALES CORPORATION OF AMERICA
Eastern Regional Office

1200 Wall Street West, Lyndhurst, New Jersey
07071, U.S.A.
Tel. 201-935-8980

Mid-Western Regional Office

1400 Morse Ave., Elk Grove Village, Ill. 60007, U.S.A.
Tel. 312-593-1550

Southern Regional Office

510 Plaza Drive College Park, Georgia 30349, U.S.A.
Tel. 404-763-0360

Western Regional Office

401 West Artesia Boulevard, Compton, California
90220, U.S.A.
Tel. 213-537-8383

HITACHI SALES CORPORATION OF HAWAII, INC.

3219 Koapaka Street Honolulu, Hawaii 96819, U.S.A.
Tel. 808-836-3621

HITACHI (HSC) CANADA INC.

3300 Trans Canada Highway, Pointe Claire, Quebec
H9R1 1B1, Canada
Tel. 514-697-9150

HITACHI SALES EUROPA GmbH

2050 Hamburg 54, Rungedamm 2, West Germany
Tel. 73411-0

HITACHI SALES (U.K.) Ltd.

Hitachi House, Station Road, Hayes, Middlesex UB3
4DR, England
Tel. 01-848-8787 (Service Centre: 01-848-3551)

HITACHI SALES SCANDINAVIA AB

Rissneleden 8, Box 7138, 172-07 Sundbyberg,
Sweden
Tel. 08-98 52 80

HITACHI SALES NORWAY A/S

Oerebekk 1620 Gressvik P.O. Box 46 N-1601
Fredrikstad, Norway
Tel. 032-28255

SUOMEN HITACHI OY

Takojankatsu 5, 15800 Lahti 80, Finland
Tel. Lahti 44 241

HITACHI SALES A/S

Kuldysen 13, DK-2630 Taastrup, Denmark
Tel. 02-999200

HITACHI SALES A.G.

Bahnhofstrasse, 19, 5600 Lenzburg,
Switzerland
Tel. 064-513621

HITACHI FRANCE S.A.

97/115 Rue Charles-Michels 93200
SAINT-DENIS, France
Tel. 201-25-00

HITACHI SALES WARENHANDELS GMBH

A-1180/Wien, Kreuzgasse 27, Austria
Tel. (0222) 439367/8

HITACHI SALES BELGIUM S.A./N.V.

56, Chaussee de Namur, B-1400
Nivelles, Belgium
Tel. (067) 22 7181

HITACHI SALES AUSTRALIA Pty Ltd.

153 Keys Road, Moorabbin, Victoria 3189, Australia
Tel. 555-8722

HITACHI Ltd. TOKYO JAPAN

Head Office: THE HITACHI ATAGO BLDG.
No. 15-12, 2-chome Nishi-Shinbashi
Minato-ku, Tokyo 105, Japan
Tel. Tokyo (03) 502-2111