



# HITACHI SERVICE MANUAL

TY

No. 409EGF

## HTA-25F

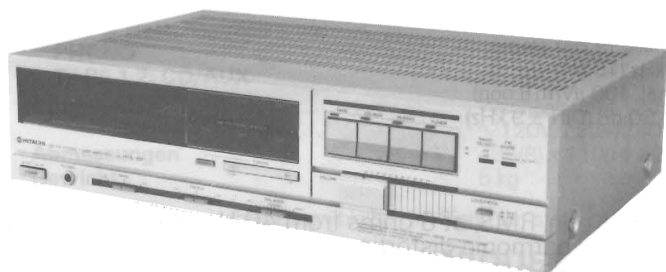

### CONTENTS

SPECIFICATIONS .....	2
DISASSEMBLY AND REPLACEMENT .....	4
BLOCK DIAGRAM .....	5
GENERAL ALIGNMENT INSTRUCTION .....	5
FM TUNER ALIGNMENT .....	6
AM TUNER ALIGNMENT .....	8
PRINTED WIRING BOARD .....	9
CIRCUIT DIAGRAM .....	10, 12
REPLACEMENT PARTS LIST .....	13

### CAUTION FOR U.S.A.

Make leakage-current or resistance measurements to determine that exposed parts are acceptably insulated from the supply circuit before returning the appliance to the customer.

### SAFETY PRECAUTIONS

The following precautions should be observed when servicing.

1. Since many parts in the unit have special safety related characteristics, always use genuine Hitachi's replacement parts. Especially critical parts in the power circuit block should not be replaced with other makers. Critical parts are marked with  $\Delta$  in the circuit diagram.
2. Before returning a repaired unit to the customer, the service technician must thoroughly test the unit to ascertain that it is completely safe to operate without danger of electrical shock.

### SICHERHEITSMASSNAHMEN

Bei Wartungsarbeiten sind die folgenden Sicherheitsmaßnahmen zu beachten:

1. Da verschiedene Teile dieses Gerätes Sicherheitsfunktionen aufweisen, nur Original-Hitachi-Ersatzteile verwenden. Kritische Teile im Netzteil sollten nicht durch ähnliche Teile anderer Hersteller ersetzt werden. Alle kritischen Teile sind im Schaltplan mit dem Symbol  $\Delta$  gekennzeichnet.
2. Vor der Auslieferung eines reparierten Gerätes an den Kunden muß der Wartungstechniker das Gerät einer gründlichen Prüfung unterziehen, um sicherzustellen, daß sicherer Betrieb ohne die Gefahr von elektrischen Schlägen gewährleistet ist.

### PRECAUTIONS DE SECURITE

Les précautions suivantes doivent être observées chaque fois qu'une réparation doit être faite.

1. Etant donné que de nombreux composants de l'appareil possèdent des caractéristiques relatives à la sécurité, utiliser uniquement des pièces de rechange d'origine Hitachi pour effectuer un remplacement. Ceci se rapporte notamment aux pièces critiques du bloc d'alimentation qui ne doivent en aucun cas être remplacées par celles d'autres fabricants. Les pièces critiques sont accompagnées du symbole  $\Delta$  dans le schéma de montage.
2. Avant de retourner l'appareil réparé au client, le technicien doit procéder à un essai complet pour s'assurer qu'il ne présente aucun danger de chocs électriques.

SPECIFICATIONS AND PARTS ARE SUBJECT TO CHANGE FOR IMPROVEMENT.

# STEREO TUNER AMPLIFIER

April 1984

TOYOKAWA WORKS

## SPECIFICATIONS

- **FM SECTION**
  - Frequency range** Europe: 87.50 – 108.00 MHz (50 kHz steps)  
U.S.A.: 87.9 – 107.9 MHz (200 kHz steps)
  - Usable sensitivity** Mono: 1.0  $\mu$ V (75 ohms, IHF and DIN)  
10.8 dBf (new IHF 300 ohms)
  - 50 dB quieting sensitivity** Mono: 18.2 dBf (4.5  $\mu$ V) Stereo: 38.2 dBf (44.7  $\mu$ V)
  - Signal-to noise ratio (at 65 dBf)** Mono: 74 dB (IHF) Stereo: 70 dB (IHF)  
70 dB (DIN) 65 dB (DIN)
  - Total harmonic distortion (at 65 dBf) 1 kHz** Mono: 0.15% Stereo: 0.25%
  - Frequency response** 30 Hz – 12 kHz ( $\pm$  2 dB)
  - Selectivity** 53 dB ( $\pm$  400 kHz IHF)  
48 dB ( $\pm$  300 kHz DIN)
  
- **AM SECTION**
  - Frequency range** Europe: 522 – 1,611 kHz (9 kHz steps)  
U.S.A.: 530 – 1,620 kHz (10 kHz steps)
  - Sensitivity** 15  $\mu$ V (IHF, ext. Antenna), 400  $\mu$ V/m (Loop)
  - Selectivity** 30 dB (IHF  $\pm$  10 kHz) 30 dB (DIN  $\pm$  9 kHz)
  - Signal-to-noise ratio (at 50 mV/m)** 50 dB
  
- **AUDIO SECTION**
  - Output**
  - RMS Power** 25 Watts per channel, min. RMS, at 8 ohms from 40 Hz to 20 kHz, with  
(Both channels driven) no more than 0.5% total harmonic distortion.  
25W + 25W (8 ohms, 1 kHz, T.H.D. 0.5% IHF and DIN)
  - Power bandwidth** 20 Hz – 40 kHz (1/2 RMS power, T.H.D. 0.5% at 8 ohms)
  - Total harmonic distortion** Less than 0.5%  
(at rated output)
  - Intermodulation distortion** 0.5%  
(at 1/2 rated output)
  - Input sensitivity**
  - (at 25W output, 1 kHz)**
  - PHONO** 2.5 mV (47 k-ohms)
  - TAPE 1, 2; CD/AUX** 150 mV (35 k-ohms)
  - Phono over load level** 140 mV (T.H.D. 0.05% at 1 kHz)
  - Output level**
  - TAPE OUT** 150 mV (PHONO at rated input)  
150 mV (FM 400 Hz, 30% mod. input: 1 mV)  
150 mV (AM 400 Hz, 30% mod. input: 5 mV/m)
  - Signal-to-noise ratio**
  - (IHF, A network, rated power)**
  - PHONO** 72 dB
  - TAPE 1, 2; CD/AUX** 95 dB
  
- **GENERAL**
  - Power requirements** AC 120V 60 Hz,  $\sim$  220V 50 Hz,  $\sim$  240V 50 Hz or  $\sim$  120V/220V/240V 50/60 Hz
  - Dimensions** 435(W) x 110(H) x 290 (D) mm  
17-1/8 (W) x 3-1/4(H) x 14-1/8(D) in.
  - Weight** 5 kg

## TECHNISCHE DATEN

- **FM-TEIL**
  - Empfangsbereich** Europa: 87,50 MHz bis 108,00 MHz (50 kHz Raster)  
USA : 87,9 MHz bis 107, 9 MHz (200 kHz Raster)
  - Nutzempfindlichkeit** Mono: 1,0  $\mu$ V (75 Ohm, IHF und DIN)  
10,8 dBf (neue IHF 300 Ohm)
  - Grenzeempfindlichkeit (bei 50 dB)** Mono: 18,2 dBf (4,5  $\mu$ V) Stereo: 38,2 dBf (44,7  $\mu$ V)
  - Fremdspannungsabstand (bei 65 dBf)** Mono: 74 dB (IHF) Stereo: 70 dB (IHF)  
70 dB (DIN) 65 dB (DIN)
  - Klirrfaktor (bei 65 dBf)** Mono: 0,15% Stereo: 0,25%  
1 kHz
  - Frequenzgang** 30 Hz – 12 kHz ( $\pm$  2 dB)
  - Selektivität** 53 dB ( $\pm$  400 kHz IHF)  
48 dB ( $\pm$  300 kHz DIN)
  
- **AM-TEIL**
  - Frequenzbereich** Europa: 522 – 1611 kHz (9 kHz Raster)  
USA: 530 – 1620 kHz (10 kHz Raster)
  - Empfindlichkeit** 15  $\mu$ V (IHF, ext. Antenne), 400  $\mu$ V/m (Rahmenantenne)
  - Trennschärfe** 30 dB (IHF  $\pm$  10 kHz) 30 dB (DIN  $\pm$  9 kHz)
  - Signal/Rausch-Abstand (bei 50 mV/m)** 50 dB
  
- **AUDIO-TEIL**
  - Ausgangsleistung** 25W + 25W (an 8 Ohm, 40 Hz – 20 kHz, Klirrgrad 0,5%)  
25W + 25W (an 8 Ohm, 1 kHz, Klirrgrad 0,5% IHF und DIN)

<b>Leistungsbandbreite</b>	10 Hz – 40 kHz (1/2 RMS-Sinusleistung, T.H.D. 0,03% bei 8 Ohm)
<b>Klirrfaktor</b> (bei Nennleistung)	Weniger als 0,5%
<b>Intermodulationsverzerrung</b> (bei 1/2 Nennleistung)	0,5%
<b>Eingangsempfindlichkeit</b> (bei 25W Abgabeleistung, 1 kHz)	
<b>PHONO</b>	2,5 mV (47 kOhm)
<b>Band (TAPE 1,2); CD/AUX</b>	150 mV (35 kOhm)
<b>Phonoüberlastungspegel</b>	140 mV (T.H.D. 0,05% bei 1 kHz)
<b>Ausgangspegel</b>	
<b>Tonband-Ausgang (TAPE OUT)</b>	150 mV (PHONO bei Nenneingang) 150 mV (FM 400 Hz, 30% Mod. Eingang: 1 mV) 150 mV (AM 400 Hz, 30% Mod. Eingang: 5 mV/m)
<b>Geräuschspannungsabstand</b> (IHF A Netz, Nennleistung)	
<b>PHONO</b>	72 dB
<b>TAPE 1,2; CD/AUX</b>	95 dB
<b>Strombedarf</b>	Wechselstrom 120V 60 Hz, ~ 220V 50 Hz, ~ 240V 50 Hz oder ~ 120V/220V/240V 50/60 Hz
<b>Abmessungen</b>	435(B) x 110(H) x 290(T) mm
<b>Gewicht</b>	5 kg

Änderungen der technischen Daten bleiben im Sinne der ständigen Verbesserung vorbehalten.

## CARACTERISTIQUES TECHNIQUES

### ● SECTION FM

#### Bande de fréquences

Europe: 87,50 – 108,00 MHz (par paliers de 50 kHz)

U.S.A. : 87,9 – 107,9 MHz (par paliers de 200 kHz)

#### Sensibilité utilisable

Mono: 1,0  $\mu$ V (75 ohms, IHF et DIN)

10,8 dBf (nouvelle IHF 300 ohms)

#### Seuil de sensibilité 50 dB

Mono: 18,2 dBf (4,5  $\mu$ V)

Stéréo: 38,2 dBf (44,7  $\mu$ V)

#### Rapport signal/bruit (65 dBf)

Mono: 74 dB (IHF)

Stéréo: 70 dB (IHF)

70 dB (DIN)

65 dB (DIN)

#### Distorsion harmonique (65 dBf)

1 kHz

Mono: 0,15%

Stéréo: 0,25%

#### Réponse en fréquence

#### Sélectivité

30 Hz – 12 kHz ( $\pm$  2 dB)

53 dB ( $\pm$  400 kHz IHF)

48 dB ( $\pm$  300 kHz DIN)

### ● SECTION AM

#### Bande de fréquence

Europe: 522 – 1 611 kHz (par paliers de 9 kHz)

U.S.A.: 530 – 1 620 kHz (par paliers de 10 kHz)

#### Sensibilité

15  $\mu$ V (Antenne ext., IHF), 400  $\mu$ V/m (Cadre)

#### Sélectivité

30 dB (IHF  $\pm$  10 kHz) 30 dB (DIN  $\pm$  9 kHz)

#### Rapport signal/bruit (50 mV/m)

50 dB

### ● SECTION AUDIO

#### Sortie

25W + 25W (8 ohms, 40 Hz – 20 kHz, D.H.T. 0,5%)

25W + 25W (8 ohms, 1 kHz, D.H.T. 0,5% IHF et DIN)

20 Hz – 40 kHz (Puissance 1/2 RMS, D.H.T. 0,5% à 8 ohms.)

#### Bande passante

#### Distorsion harmonique

(à la puissance réelle)

Infrérieure à 0,5%

#### Distorsion d'intermodulation

(à la moitié de la puissance réelle)

0,5%

#### Sensibilité d'entrée

(sous 25W 1 kHz de sortie)

PHONO

2,5 mV (47k ohms)

TAPE 1,2; AUX/VIDEO

150 mV (35k ohms)

#### Niveau de surcharge phono

140 mV (avec une D.H.T. de 0,05% à 1 kHz)

#### Niveau de sortie

TAPE OUT

150 mV (PHONO, à l'entrée nominale)

150 mV (FM 400 Hz, 30% d'entrée mod.: 1 mV)

150 mV (AM 400 Hz, 30% d'entrée mod.: 5 mV/m)

#### Rapport signal/bruit

(IHF, réseau A, puissance nominale)

PHONO

72 dB

TAPE 1,2; AUX/VIDEO

95 dB

#### Alimentation

C.A. 120V 60 Hz, ~ 220V 50 Hz, ~ 240V 50 Hz ou ~ 120V/220V/240V 50/60 Hz

#### Dimensions

435(L) x 110(H) x 290(P) mm

#### Poids

5 kg

Les caractéristiques techniques et la présentation peuvent être modifiées sans préavis pour des raisons d'améliorations.

**DISASSEMBLY AND REPLACEMENT · ZERLEGUNG UND AUSTUSCH · DEMONTAGE ET REMONTAGE**

- Removing the printed wiring boards.
- Ausbau der Leiterplatten
- Déposer des plaquettes à circuit imprimé

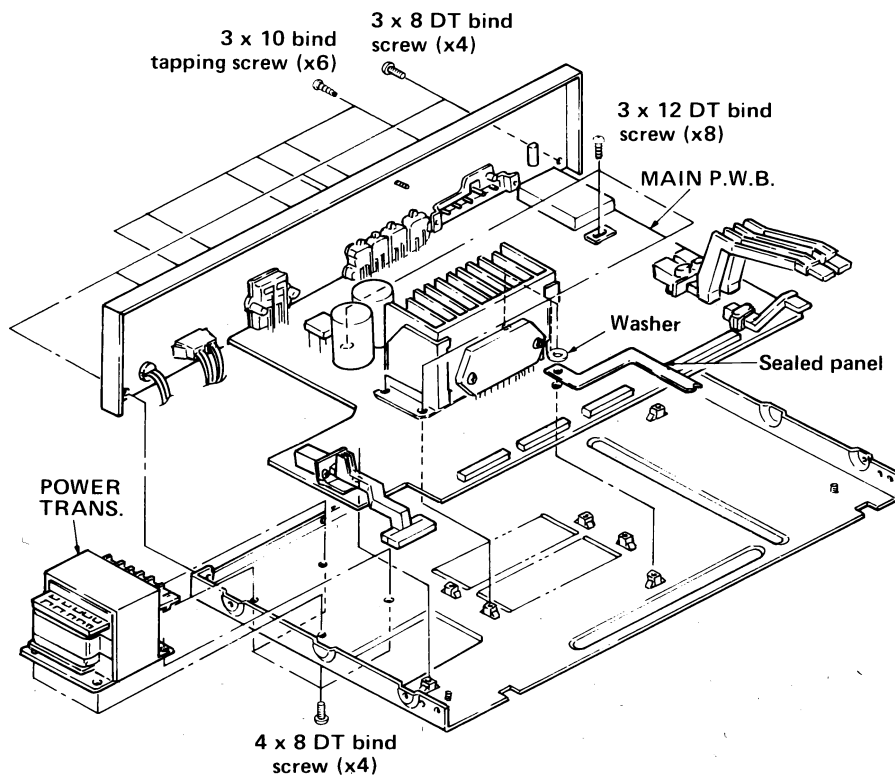
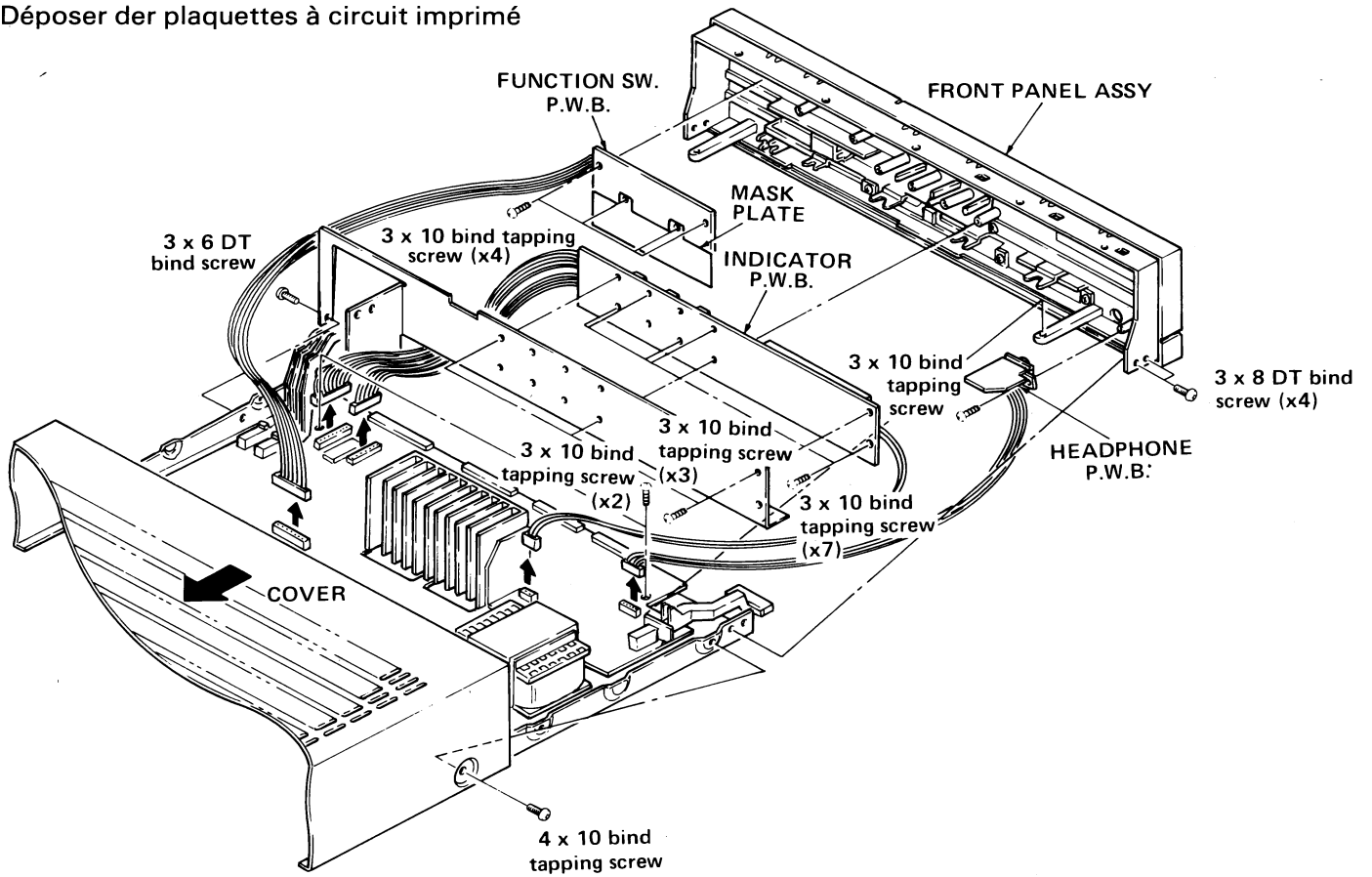



**BLOCK DIAGRAM · BLOCK SCHEMA · SCHEMA**

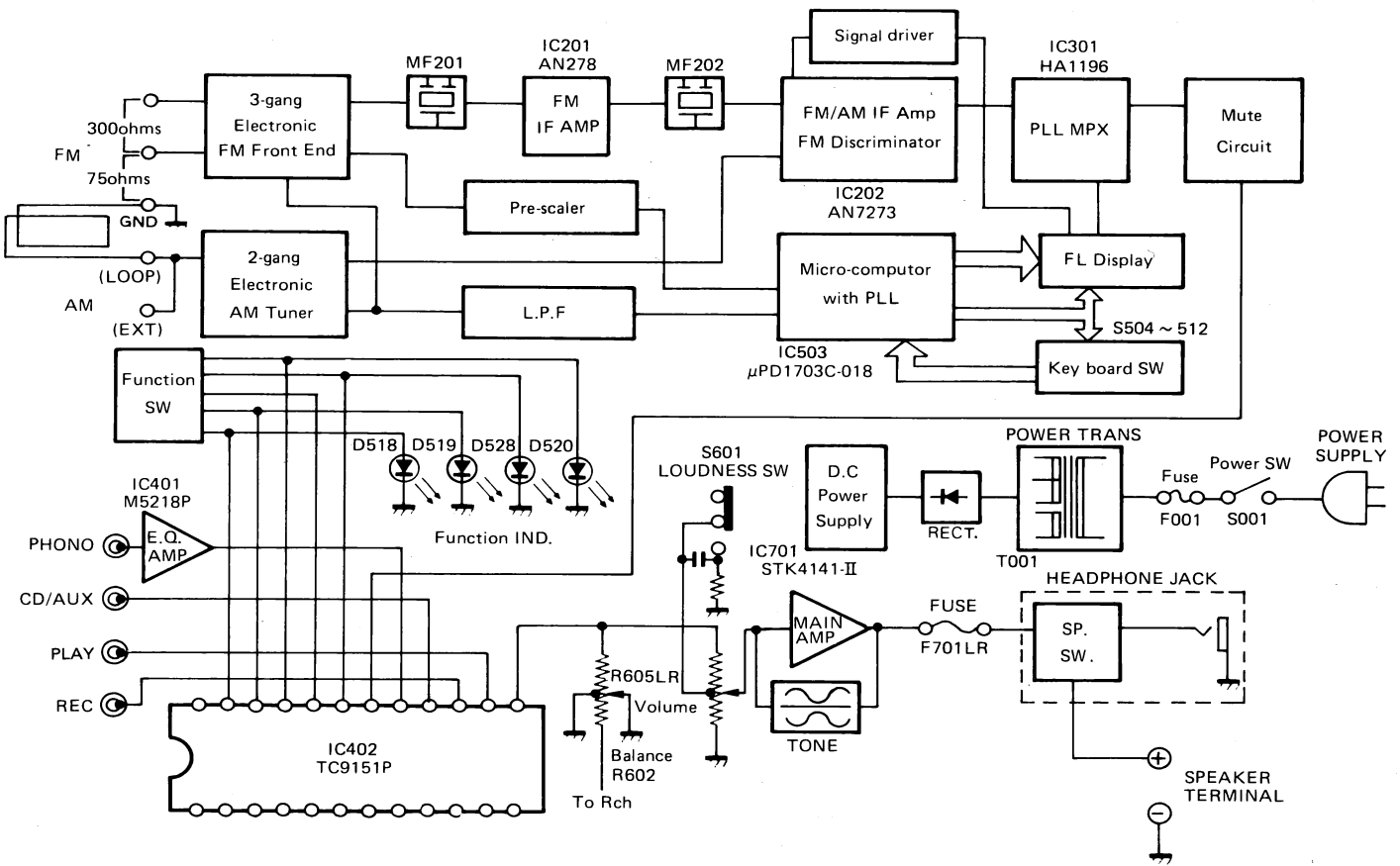

**GENERAL ALIGNMENT INSTRUCTION · ALLGEMEINE AUSRICHTANLEITUNG · INSTRUCTIONS GENERALES**

- TA P.W.B.
- TA-Leiterplatte
- Plaque à circuits imprimés TA

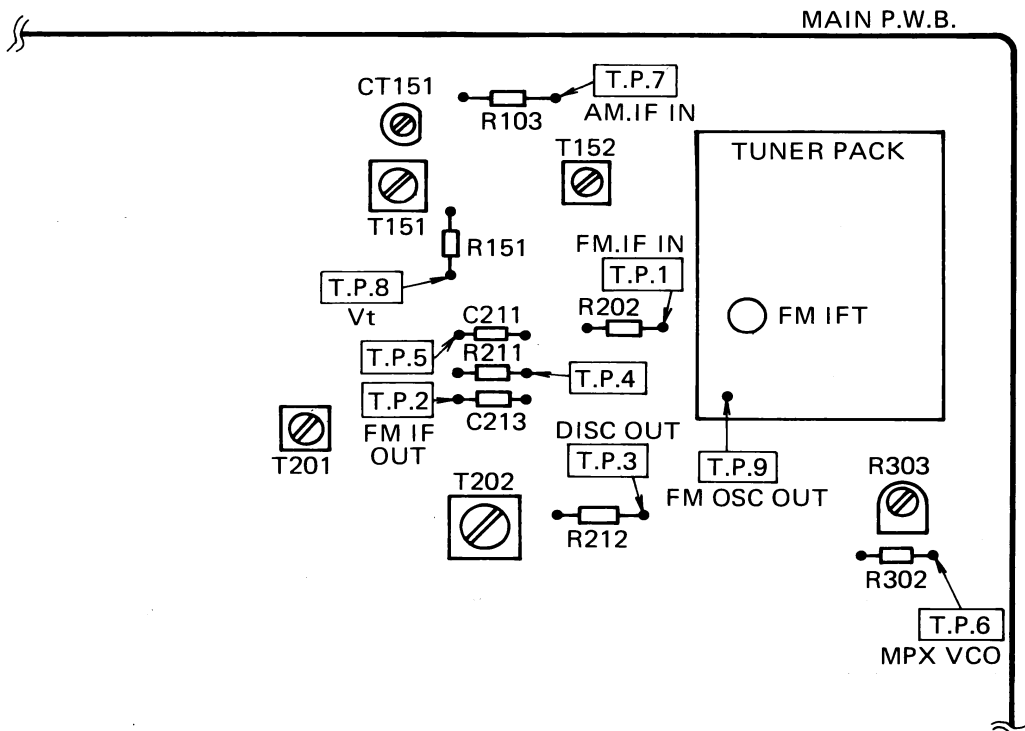



# FM TUNER ALIGNMENT · ABGLEICH DES UKW-TUNERS · REGLAGE DE TUNER FM

FUNCTION: Tuner (FM)  
 Funktion: Tuner  
 FUNCTION: Tuner

VOLUME: MIN  
 Lautstärke: Minimum  
 VOLUME: min.

FM MODE: MONO

 Sweep Generator  
 Wobbelgenerator  
 Générateur de balayage

 Signal Generator  
 Signalgenerator  
 Générateur de signaux

 Oscilloscope  
 Oszilloskop  
 Oscilloscope

 + DC Null Meter  
 Gleichstrom-Nullmeter  
 - Indicateur d'équilibrage à C. C.

 VTVM  
 V.T.V.M.  
 Voltmètre électronique

 Frequency Counter  
 Frequenzzähler  
 Fréquence-mètre

Dist.  
 Distortion Meter  
 Klirrmesser  
 Distorsionmètre

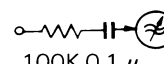
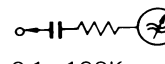
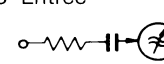
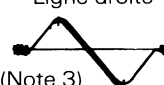
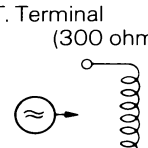
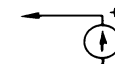
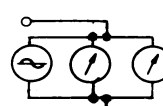
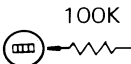
Sequence Folge Ordre	Connection Anschlüsse Connexion		Setting Einstellung Montage		Adjust for Einstellung für Réglage pour		
	Input Eingang Entrée	Output Ausgang Sortie	Tuning Abstimm- anzeige Indicateur d'accord	Signal Signal Signal	Adjust Einstellpunkt Réglage	Indication Indikation Indication	
1		IN Eingang Entrée  100K 0.1 µ	—	10.7 MHz	FM IFT (Tuner Pack) (Tuner-Teil) (Ensemble Tuner)	(Note 2) (Hinweis 2)	
2	TP.1 Out Ausgang Sortie  0.1µ 100K	IN Eingang TP.3 Entrée  100K 0.1 µ	—	10.7 MHz	T202 "S" curve S-Kurve Courbe en forme de "S"	 (Note 3) (Hinweis)	
3	ANT. Terminal (300 ohms) 	TP. 4  TP. 5	98.1 or 98.00 MHz	98.1 or 98.00 MHz	T202	(Note 4) (Hinweis 4)	
4	1 kHz, 60 dBµ 75 kHz (dev.) (for U.S.A. Canada) 40 kHz (dev.) (except U.S.A. Canada)	REC OUT  Dist.	98.1 or 98.00 MHz	98.1 or 98.00 MHz	—	—	
5	Covering Bereich Portée	—					(Note 5) (Hinweis 5)
6	Tracking Nachführung Alignement	—					(Note 5) (Hinweis 5)
7	76 kHz (FM MODE: AUTO)  ANT. Terminal (300) ohms 60 dBµ  Non modulated Nicht moduliert Sans modulation	100K  TP. 6	98.1 or 98.00 MHz	98.1 or 98.00 MHz	R303	76 kHz ± 100 Hz	

- **(Note 1)**  
Perform adjustment at least 3 minutes after the power has been switched on.
  - **(Note 2)**  
Using a sweep generator, apply low-input signals (with a small amount of noise superimposed as in fig. A), and adjust the FM IFT so that the waveforms are brought to their maximum in center marker frequency (10.7 MHz).
  - **(Note 3)**  
Adjust the T202 coil and obtain an S-curve.
  - **(Note 4)**  
Connect a DC null meter and adjust T201 for a reading of  $0V \pm 30 \text{ mV}$ .
  - **(Note 5)**  
FM Tuner pack is aligned before shipping, so it is not necessary to adjust covering and tracking.
- 

- **(Hinweis 1)**  
Den Abgleich frühestens 3 Minuten nach dem Einschalten des Netzschalters durchführen.
  - **(Hinweis 2)**  
Mit Hilfe eines Wobbelgenerators sind niederpegelige Signale (mit geringer Rauschstörung an der Anstiegsflanke der in Abb. A) anzulegen; FM IFT so abgleichen, daß Wellenform an der Mittenmarkierungsfrequenz (10,7 MHz) ein Maximum annimmt.
  - **(Hinweis 3)**  
T202 abgleichen, um eine S-Kurve zu erhalten.
  - **(Hinweis 4)**  
Einen Gleichspannungsmesser und T201 eine Anzeige von  $0V \pm 30 \text{ mV}$  einstellen.
  - **(Hinweis 5)**  
Das UKW-Empfangsteil wurde vor dem Versand eingestellt, so daß der Bereich und die Nachführung nicht einjustiert werden müssen.
- 

- **(Note 1)**  
Effectuer ce réglage au moins 3 minutes après la mise sous tension.
- **(Note 2)**  
Utiliser un générateur de balayage et appliquer des signaux d'entrée à faible niveau (avec un faible chevauchement de bruit comme représenté sur la figure A), et ajuster FM IFT pour amener les formes d'ondes à leur maximum de la fréquence nominale de repérage (10,7 MHz).
- **(Note 3)**  
Ajuster la bobine T202 pour obtenir une courbe en forme de "S".
- **(Note 4)**  
Raccorder un indicateur de zéro à courant continu et ajuster le T201 pour obtenir une lecture de  $0V \pm 30 \text{ mV}$ .
- **(Note 5)**  
L'étage tuner FM est réglé avant son envoi, il est donc inutile d'effectuer le réglage de portée et d'alignement.

**AM TUNER ALIGNMENT · ABLEICH DES AM-TUNERS · REGLAGE DE TUNER AM**

Condition: Function: TUNER (AM)  
Modulation: 400 Hz 30%

Bedingung: Funktion: TUNER  
Modulation: 400 Hz 30%

Conditions: Fonction: TUNER  
Modulation: 400 Hz 30%

Sequence Folge Ordre	Connection Anschlüsse Connexion		Setting Einstellung Montage		Adjust for Einstellung für Réglage pour	
	Input Eingang Entrée	Output Ausgang Sortie	Tuning Abstimm- anzeige Indicateur d'accord	Signal Signal Signal	Adjust Einstellpunkt Réglage	Indication Indikation Indication
1	IF Amp. ZF Verstärker Amplificateur de fréquence intermédiaire  Out Ausgang Sortie  0.1μ 100K	IN Eingang Entrée  TP.3 100K 0.1 μ	—	450 kHz	T201	 Caution 1 Vorsicht 1 Attention 1
2	Loop antenna Rahmenantenne Antenne en carton	TP8 GND 	530 kHz or 522 kHz	—	T152	530 kHz : 1.3 VDC 522 kHz : 1.2 VDC Caution 2 Vorsicht 2 Attention 2
3	Tracking Vorstufe Alignement 	REC OUT 	600 kHz or 603 kHz 1400 kHz or 1404 kHz	600 kHz or 603 kHz 1400 kHz or 1404 kHz	T151 CT151	Output max. Caution 3 Vorsicht 3 Attention 3

**Caution**

1. Adjust T201 so that the waveform is as shown in Fig. B. After adjusting as above, increase the output level of the sweep generator and adjust T201 again so that the top of the waveform A (indicated in Fig. C) will be flat and wide.
2. Carry out this adjustment for final adjustment of the coil only when you have moved the core by mistake.
3. Set the input level to 74 dB/m in coarse adjustment. Reduce the input level to minimum (50 dB/m) as adjustment proceeds.

**Vorsicht**

1. Die T201 so einstellen, daß die Kurvenform der in Abb. B dargestellten entspricht. Nach der zuvor beschriebenen Einstellung den Ausgangspegel des Oszillators erhöhen und T201 abermals einstellen, so daß die Spitze der Kurvenform A (s. Abb. C) flach und breit wird.
2. Diese Einstellung zur abschließenden Angleichung der Spule nur vornehmen, wenn der Kern irrtümlich bewegt wurde.
3. Den Eingangspegel auf 74 dB/m grob einstellen. Auf minimal 50 dB/m nach Verlauf der Einstellung zurückstellen.

**Attention**

1. Régler T201 de façon à obtenir une forme d'onde comme indiquée sur la Fig. B. Après avoir réglé comme indiqué ci-dessus, augmenter le niveau d'entrée du générateur de balayage et régler T201 à nouveau de façon que le sommet de la forme d'onde A (voir Fig. C) soit aplati et large.
2. N'effectuer le dernier réglage de la bobine par ce réglage que si vous avez bougé l'âme par erreur.
3. Faire un réglage approximatif du niveau d'entrée à 74 dB/m.  
Réduire le niveau d'entrée jusqu'à un minimum de 50 dB/m à mesure que l'on effectue réglage.

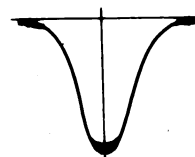

Fig. B Abb. B

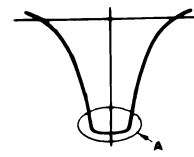
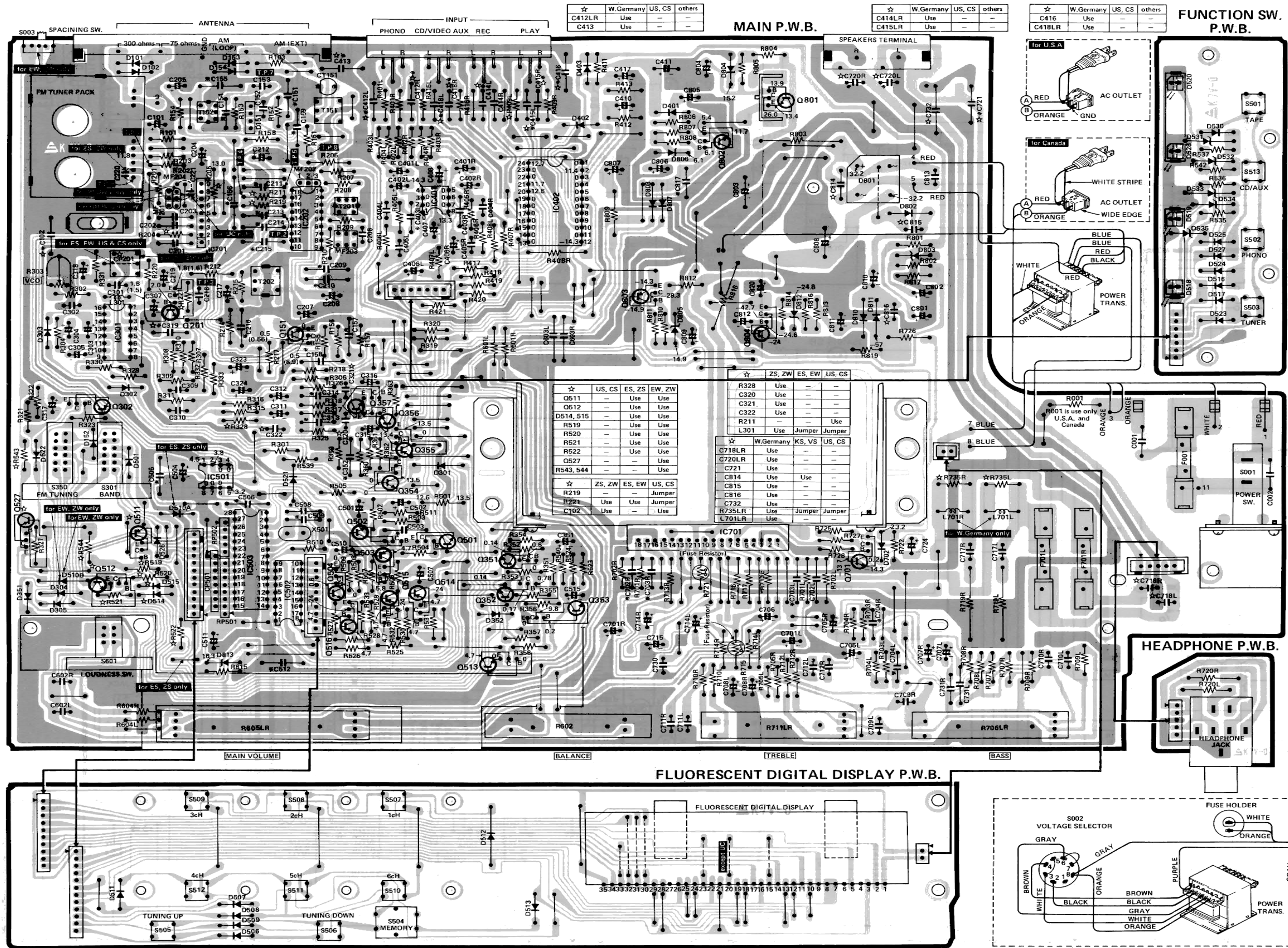

Fig. C Abb. C

PRINTED WIRING BOARD · PRINTPLATTEN · PLAN DE BASE



CIRCUIT DIAGRAM · SCHALTPLAN · PLAN DE CIRCUIT

- \* Axial lead cylindrical ceramic capacitor
- \* Zylindrischer Keramik Kondensator mit axialer Zuleitung
- \* Condensateur céramique cylindrique à conducteur axial

**CAUTION**  
Use the electrolytic capacitors with explosion-proof valve when the diameter of them is more than 10 mmφ.

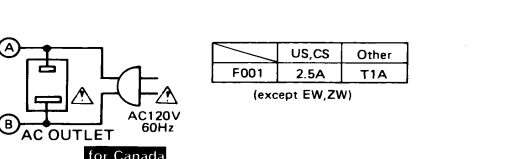
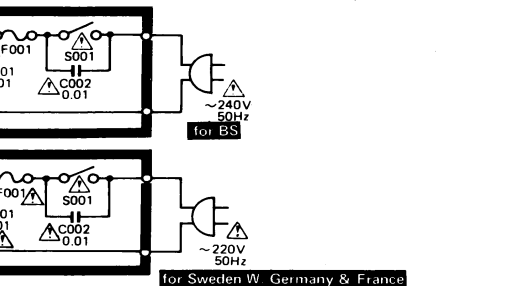
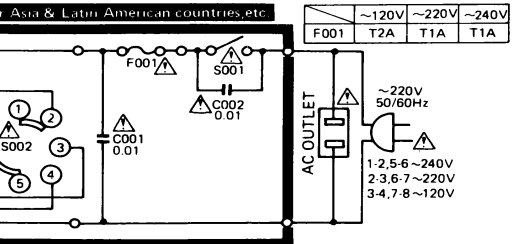
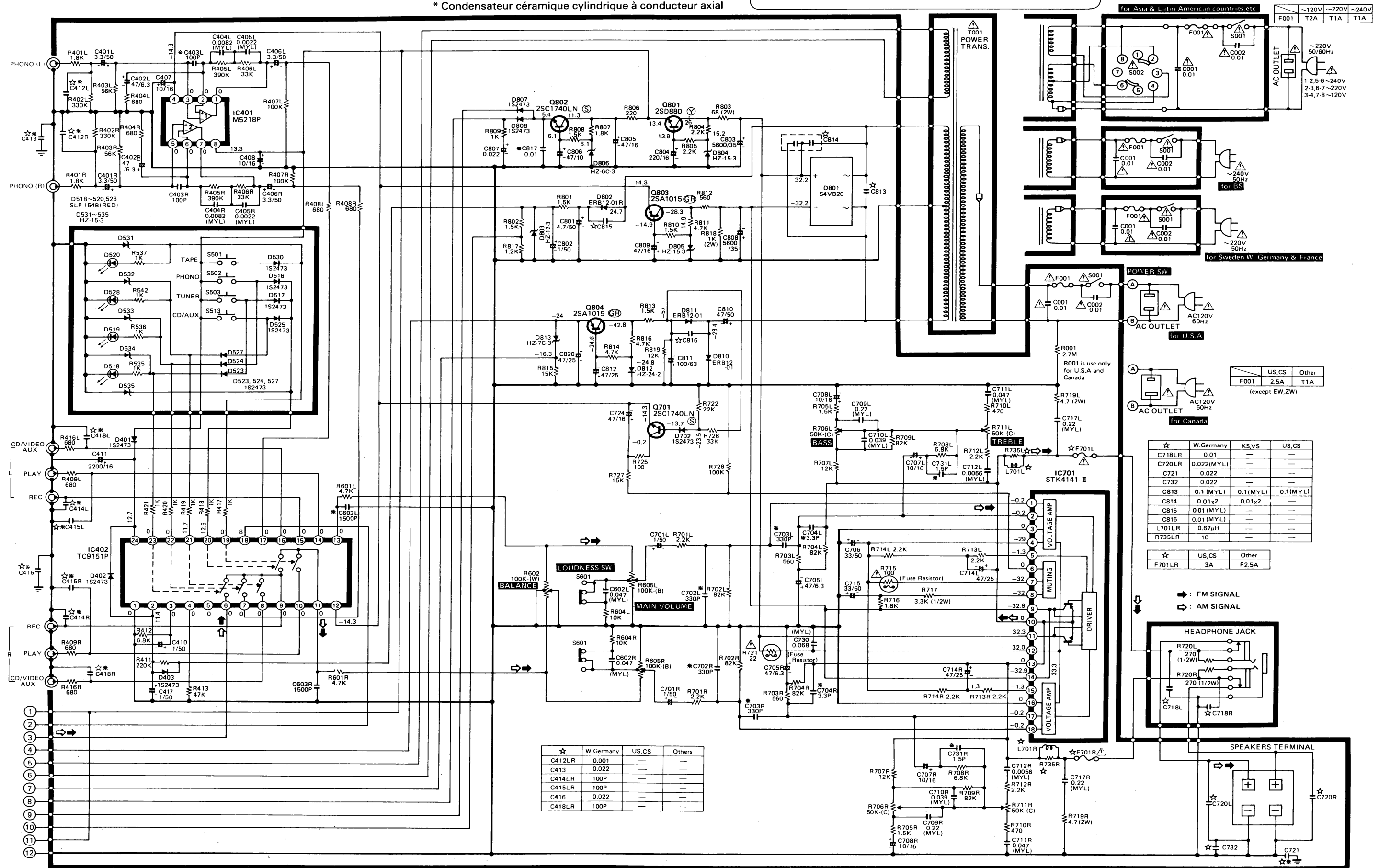

	US,CS	Other
F001	2.5A	T1A

☆	W.Germany	KS,VS	US,CS
C718LR	0.01	—	—
C720LR	0.022(MYL)	—	—
C721	0.022	—	—
C732	0.022	—	—
C813	0.1(MYL)	0.1(MYL)	0.1(MYL)
C814	0.01x2	0.01x2	—
C815	0.01(MYL)	—	—
C816	0.01(MYL)	—	—
L701LR	0.67μH	—	—
R735LR	10	—	—

☆	US,CS	Other
F701LR	3A	F2.5A



☆	W.Germany	US,CS	Others
C412LR	0.001	—	—
C413	0.022	—	—
C414LR	100P	—	—
C415LR	100P	—	—
C416	0.022	—	—
C418LR	100P	—	—

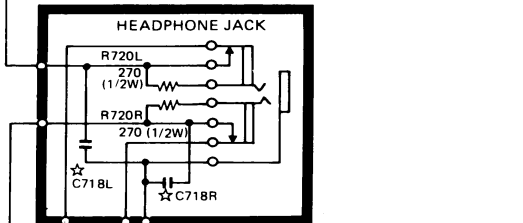
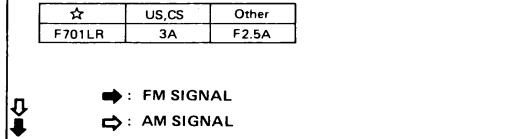

CIRCUIT DIAGRAM · SCHALTPLAN · PLAN DE CIRCUIT

**CAUTION**  
Use the electrolytic capacitors with explosion-proof valve when the diameter of them is more than 10 mmφ.

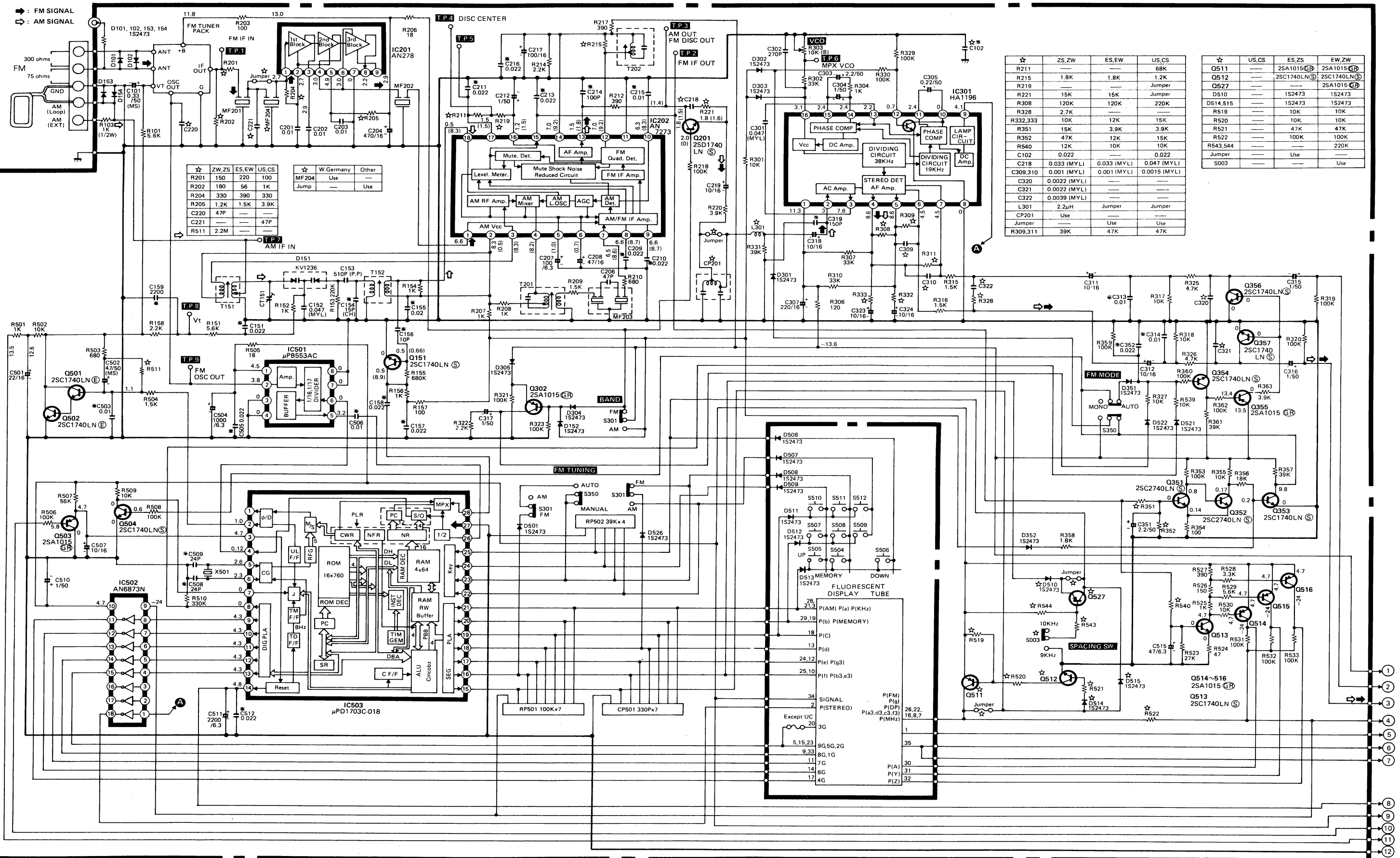

☆	ZW,ZS	ES,EW	US,CS
R201	150	220	100
R202	180	56	1K
R204	330	390	330
R205	1.2K	1.5K	3.9K
C220	47P		47P
C221			47P
R511	2.2M		

☆	W.Germany	Other
MF204	Use	
Jump		Use

☆	ZS,ZW	ES,EW	US,CS
R211			68K
R215	1.8K	1.8K	1.2K
R219			Jumper
R221	15K	15K	Jumper
R308	120K	120K	220K
R328	2.7K		
R332,333	10K	12K	15K
R351	15K	3.9K	3.9K
R352	47K	12K	15K
R540	12K	10K	10K
C102	0.022		0.022
C218	0.033 (MYL)	0.033 (MYL)	0.047 (MYL)
C309,310	0.001 (MYL)	0.001 (MYL)	0.0015 (MYL)
C320	0.0022 (MYL)		
C321	0.0022 (MYL)		
C322	0.0039 (MYL)		
L301	2.2μH	Jumper	Jumper
CP201	Use	Use	Use
Jumper		Use	Use
R309,311	39K	47K	47K

☆	US,CS	ES,ZS	EW,ZW
Q511		2SA1015 (GP)	2SA1015 (GP)
Q512		2SC1740LN (S)	2SC1740LN (S)
Q527			2SA1015 (GP)
D510		1S2473	1S2473
D514,515		1S2473	1S2473
R519		10K	10K
R520		10K	10K
R521		47K	47K
R522		100K	100K
R543,544			220K
Jumper		Use	
S003			Use

CIRCUIT DIAGRAM · SCHALTPLAN · PLAN DE CIRCUIT

Tuner pack

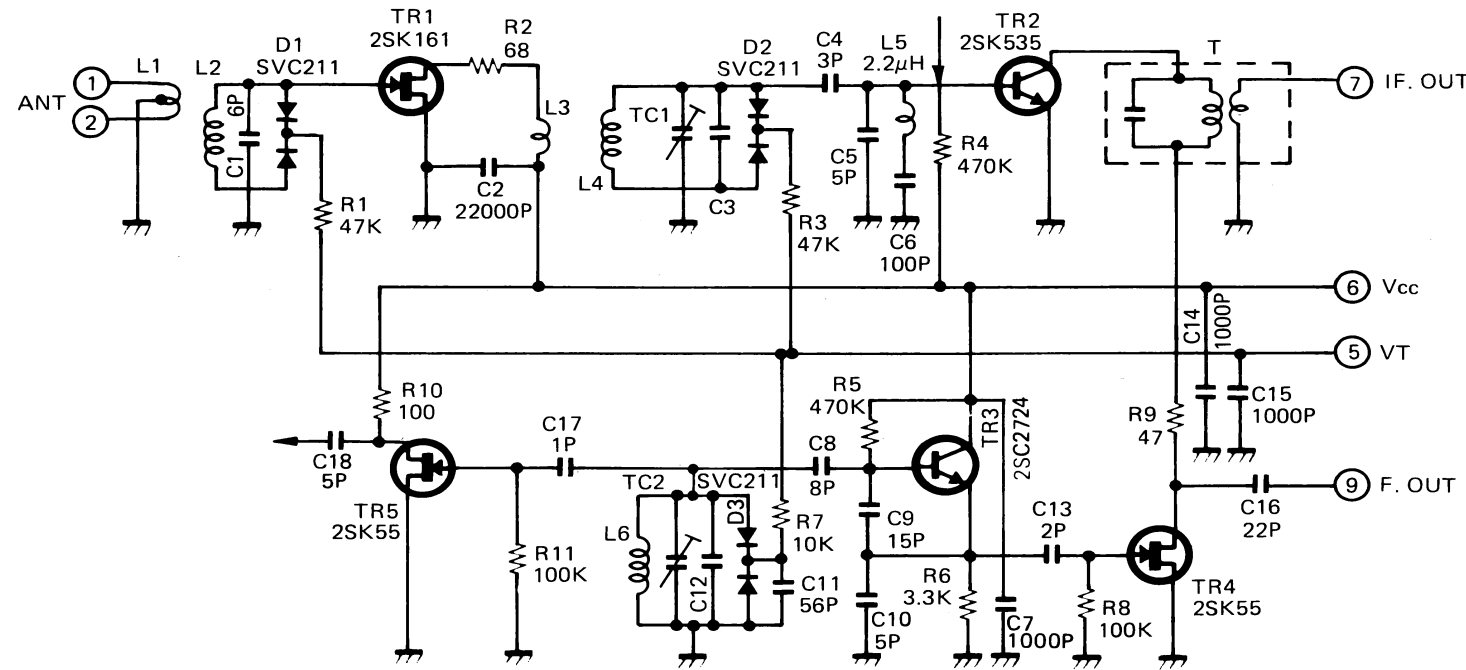

[For West Germany]

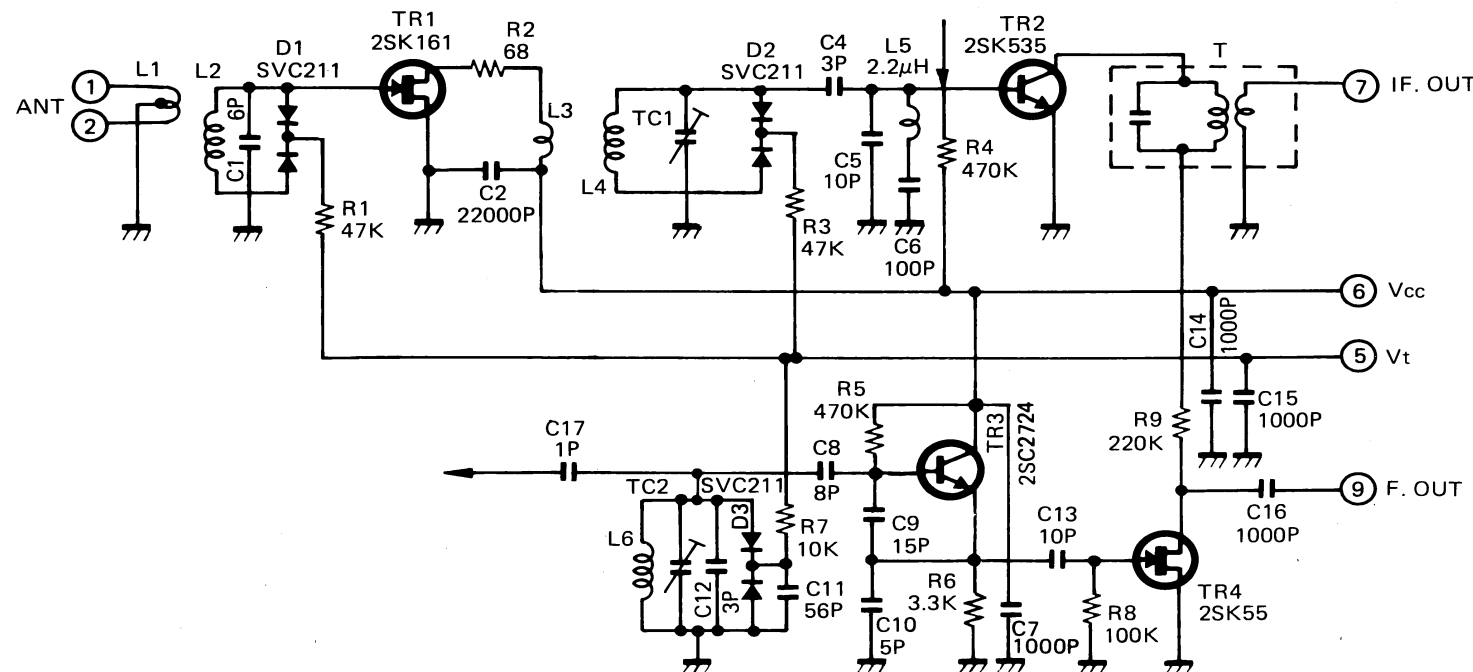

[For the others]

REPLACEMENT PARTS LIST · ERSATZTEILLISTE · TABLEAU DES PIÈCES

CD... Ceramic Discal    EL... Electrolytic    SP... Super Capacitors    ME... Metal    CO... Composition  
 CC... Cylindrical Ceramic    MF... Mylar Film    CF... Carbon Film    MO... Metal, Oxide    FR... Fuse Resistor

SYMBOL NO.	PART NO.	DESCRIPTION	SYMBOL NO.	PART NO.	DESCRIPTION	SYMBOL NO.	PART NO.	DESCRIPTION
<b>CAPACITORS</b>								
C001	0243901	CD 0.01μF +100% 400V	C312	0252521	EL 10μF 16V	C704LR	0230006	CC 330pF ±5% 50V
C002	0243901	CD 0.01μF +100% 400V	C313	0240120	CC 0.01μF ±30% 16V	C705LR	0252225	EL 47μF 6.3V
C101	0252874	EL 0.33μF 50V	C314	0240120	CC 0.01μF ±30% 16V	C706	0252823	EL 33μF 50V
C102	0240108	CC 0.022μF ±30% 16V (for U.S.A. & Canada)	C315	0252811	EL 1μF 50V	C707LR	0252521	EL 10μF 16V
C151	0240108	CC 0.022μF ±30% 16V	C316	0252811	EL 1μF 50V	C708LR	0252521	EL 10μF 16V
C152	0275015	MF 0.047μ ±10% 50V	C317	0252811	EL 1μF 50V	C709LR	0276013	MF 0.22μF ±10% 50V
C153	0279326	Pp 510pF ±2% 100V	C318	0252521	EL 10μF 16V	C710LR	0275034	MF 0.039μF ±10% 50V
C154	0230066	CC 15pF ±5% 50V	C319	0240002	CC 150μF ±10% 50V	C711LR	0275015	MF 0.047μF ±10% 50V
C155	0240108	CC 0.022μF ±30% 16V	C320	0274013	MF 2200pF ±10% 50V (for W. Germany)	C712LR	0274035	MF 5600pF ±10% 50V
C156	0230012	CC 10pF ±5% 50V	C321	0274013	MF 2200pF ±10% 50V (for W. Germany)	C714LR	0252625	EL 47μF 25V
C157	0240108	CC 0.022μF ±30% 16V	C322	0274034	MF 3900pF ±10% 50V (for W. Germany)	C715LR	0252823	EL 33μF 50V
C158	0240108	CC 0.022μF ±30% 16V	C323	0252521	EL 10μF ±10% 16V	C717LR	0276013	MF 0.22μF ±10% 50V
C159	0240102	CC 2200pF ±30% 25V	C324	0252521	EL 10μF ±10% 16V	C718	0244171	CD 0.01μF +80% -20% 50V (for W. Germany)
C201	0240120	CC 0.01μF ±30% 16V	C351	0252812	EL 2.2μF 50V	C720LR	0275013	EL 0.022μF ±10% 50V (for W. Germany)
C202	0240120	CC 0.01μF ±30% 16V	C352	0240108	CC 0.022μF ±30% 16V	C721	0240108	CC 0.022μF ±30% 16V (for W. Germany)
C203	0240120	CC 0.01μF ±30% 16V	C401LR	0252813	EL 3.3μF 50V	C724	0252525	EL 47μF 16V
C204	0252535	EL 470μF 16V	C402LR	0252225	EL 47μF 6.3V	C730	0275016	MF 0.068μF ±10% 50V
C206	0246456	CD 47pF ±5% 50V	C403LR	0230036	CC 100 pF ±5% 50V	C732	0240108	CC 0.022μF ±30% 16V (for W. Germany)
C207	0252231	EL 100μF 6.3V	C404LR	0274036	MF 0.0082μF ±10% 50V	C731LR	0230002	CC 1.5pF ±20% 50V
C208	0252525	EL 47μF 16V	C405LR	0275013	EL 0.022μF ±10% 50V	C801	0252815	EL 4.7μF 50V
C209	0240108	CC 0.022μF ±30% 16V	C406LR	0252813	EL 3.3μF 50V	C802	0252811	EL 1μF 50V
C210	0240108	CC 0.022μF ±30% 16V	C407	0252521	EL 10μF 16V	C803	0259998	EL 5600μF 35V
C211	0240108	CC 0.022μF ±30% 16V	C408	0252521	EL 10μF 16V	C804	0252532	EL 220μF 16V
C212	0252811	EL 1μF 50V	C410	0252811	EL 1μF 50V	C805	0252525	EL 47μF 16V
C213	0240108	CC 0.022μF ±30% 16V	C411	0252542	EL 2200μF 16V	C806	0252325	EL 47μF 10V
C214	0230036	CC 100pF ±5% 50V	C412LR	0240020	CC 1000pD ±20% 50V (for W. Germany)	C807	0259891	SC 0.022F +80% -10% 5V
C215	0240120	CC 0.01μF ±30% 16V	C413	0240108	CC 0.022μF ±30% 16V (for W. Germany)	C808	0259998	EL 5600μF 35V
C216	0240108	CC 0.022μF ±30% 16V	C414LR	0230036	CC 100pF ±5% 50V (for W. Germany)	C809	0252525	EL 47μF 16V
C217	0252531	EL 100μF 16V	C415LR	0230036	CC 100pF ±5% 50V (for W. Germany)	C810	0252823	EL 33μF 50V
C218	0275014	MF 0.033μF ±30% 16V (except U.S.A. & Canada)	C416	0240108	CC 0.022μF ±30% 16V (for W. Germany)	C811	0252931	EL 100μF 63V
C218	0275015	MF 0.047μF ±10% 150V (for U.S.A. & Canada)	C417	0252811	EL 1μF 50V	C812	0252625	EL 47μF 25V
C219	0252521	EL 10μF 16V	C418LR	0230036	CC 100pF ±5% 50V (for W. Germany)	C813	0276511	MF 0.1μF ±10% 100V (except Asia & Latin American countries)
C220	0246456	CD 47pF ±5% 50V (for W. Germany)	C501	0252522	EL 22μF 16V	C814	0241901	CC 0.01μF +80% -20% 250V (except U.S.A, Canada & France)
C221	0246456	CD 47pF ±5% 50V (for U.S.A. & Canada)	C502	0252880	EL 4.7μF 50V	C815	0275511	MF 0.01μF ±10% 50V (for W. Germany)
C301	0275015	MF 0.047μF ±10% 50V	C503	0240120	CC 0.01μF ±30% 16V	C816	0275511	MF 0.01μF ±10% 100V (for W. Germany)
C302	0246470	CD 270pF ±5% 50V	C504	0252241	EL 1000μF 6.3V	C817	0240120	CC 0.01μF ±30% 16V
C303	0252812	MF 2.2μF 50V	C505	0240108	CC 0.022μF ±30% 16V	C820	0252625	EL 47μF 25V
C304	0252811	EL 1μF 50V	C506	0240106	CC 0.01μF ±30% 25V			
C305	0252802	EL 0.22μF 50V	C507	0252521	EL 10μF 16V			
C307	0252532	EL 220μF 16V	C508	0230071	CC 24pF ±5% 50V			
C309	0274011	MF 0.001μF ±10% 50V (except U.S.A., Canada & France)	C509	0230071	CC 24pF ±5% 50V			
C309	0274012	MF 0.0015μF ±10% 50V (for U.S.A., Canada & France)	C510	0252811	EL 1μF 50V			
C310	0274011	MF 0.001μF ±10% 50V (except U.S.A., Canada & France)	C511	0252242	EL 2200μF 6.3V			
C310	0274012	MF 0.0015μF ±10% 50V (for U.S.A., Canada & France)	C512	0240108	CC 0.022μF ±30% 16V			
			C515	252225	EL 47μF 6.3V			
			C602LR	0275015	MF 0.047μF ±10% 50V			
			C603LR	0240101	CC 0.015μF ±20% 25V			
			C701LR	0252811	EL 1μF 50V			
			C702LR	0240006	CC 330pF ±10% 50V			
			C703LR	0240006	CC 330pF ±10% 50V			

RESISTORS

RO01	0139005	CO 1kΩ ±0% RC 1/2GF (for U.S.A., Canada & France)
R101	0129619	CF 2700kΩ ±5% SRD 1/4P
R103	0134373	CO 1kΩ ±10 RC 1/2GF
R151	0129619	CF 5.6kΩ ±5% SRD 1/4P
R152	0129601	CF 1kΩ ±10% SRD 1/4P
R153	0129669	CF 220kΩ ±5% SRD 1/4P
R154	0129601	CF 1kΩ ±5% SRD 1/4P
R155	0129681	CF 680kΩ ±5% SRD 1/4P



# HITACHI HTA-25F

CD..... Ceramic Discal  
CC..... Cylindrical Ceramic

EL..... Electrolytic  
MF.... Mylar Film

SP..... Super Capacitors  
CF..... Carbon Film

ME... Metal  
MO... Metal, Oxide

CO ... Composition  
FR .... Fuse Resistor

SYMBOL NO.	PART NO.	DESCRIPTION
R156	0129601	CF 1KΩ ±5% SRD 1/4P
R157	0129561	CF 100Ω ±5% SRD 1/4P
R158	0129609	CF 2.2KΩ ±5% SRD 1/4P
R201	0129561	CF 100Ω ±5% SRD 1/4P (for U.S.A. & Canada)
R201	0129565	CF 150Ω ±5% SRD 1/4P (for W. Germany)
R201	0129569	CF 220Ω ±5% SRD 1/4P (except U.S.A., Canada & W. Germany)
R202	0129567	CF 180Ω ±5% SRD 1/4P (for W. Germany)
R202	0129549	CF 56Ω ±5% SRD 1/4P (except U.S.A., Canada & W. Germany)
R202	0129601	CF 1KΩ ±5% SRD 1/4P (for U.S.A. & Canada)
R203	0129561	CF 100Ω ±5% SRD 1/4P
R204	0129573	CF 330Ω ±5% SRD 1/4P (for U.S.A. Canada & W. Germany)
R204	0129575	CF 390Ω ±5% SRD 1/4P (for U.S.A. France, U.K, Asia & Latin American countries)
R205	0129603	CF 1.2KΩ ±5% SRD 1/4P (for W. Germany)
R205	0129605	CF 1.5KΩ ±5% SRD 1/4P (for U.K & France)
R205	0129615	CF 3.9KΩ ±5% SRD 1/4P (for U.S.A. & Canada)
R206	0123612	FR 18Ω ±5% SRD 1/4P
R207	0129601	CF 1KΩ ±5% SRD 1/4P
R208	0129601	CF 1KΩ ±5% SRD 1/4P
R209	0129605	CF 1.5KΩ ±5% SRD 1/4P
R210	0129581	CF 680Ω ±5% SRD 1/4P
R211	0129651	CF 68KΩ ±5% SRD 1/4P (for U.S.A. & Canada)
R212	0129575	CF 390Ω ±5% SRD 1/4P
R214	0129609	CF 2.2KΩ ±5% SRD 1/4P
R215	0129603	CF 1.2kΩ ±5% SRD 1/4P (for U.S.A., Canada & France)
R215	0129607	CF 1.8KΩ ±5% SRD 1/4P (except U.S.A., Canada & France)
R217	0129575	CF 390Ω ±5% SRD 1/4P
R218	0129661	CF 100KΩ ±5% SRD 1/4P
R220	0129615	CF 3.9KΩ ±5% SRD 1/4P
R221	0129635	CF 15KΩ ±5% SRD 1/4P (except U.S.A., Canada & France)
R301	0129631	CF 10KΩ ±5% SRD 1/4P
R302	0129643	CF 33KΩ ±5% SRD 1/4P
R304	0129601	CF 1KΩ ±5% SRD 1/4P
R306	0123622	FR 120Ω ±5% SRD 1/4P
R307	0129643	CF 33Ω ±5% SRD 1/4P
R308	0129669	CF 220KΩ ±5% SRD 1/4P (for U.S.A. & Canada)
R308	0129671	CF 270KΩ ±5% SRD 1/4P (except U.S.A. & Canada)
R308	0129633	CF 120KΩ ±5% SRD 1/4P (for U.S.A. & Canada)
R309	0129645	CF 39KΩ ±5% SRD 1/4P (for W. Germany)
R309	0129647	CF 47KΩ ±5% SRD 1/4P (except W. Germany)
R310	0129643	CF 33KΩ ±5% SRD 1/4P

SYMBOL NO.	PART NO.	DESCRIPTION
R311	0129645	CF 39KΩ ±5% SRD 1/4P (for W. Germany)
R311	0129647	CF 47KΩ ±50% SRD 1/4P (except W. Germany)
R331	0129647	CF 47KΩ ±5% SRD 1/4P
R315	0129605	CF 1.5KΩ ±5% SRD 1/4P
R316	0129605	CF 1.5KΩ ±5% SRD 1/4P
R316	0129605	CF 1.5KΩ ±5% SRD 1/4P
R317	0129631	CF 10KΩ ±5% SRD 1/4P
R318	0129631	CF 10KΩ ±5% SRD 1/4P
R319	0129661	CF 100KΩ ±5% SRD 1/4P
R320	0129661	CF 100KΩ ±5% SRD 1/4P
R321	0129661	CF 100KΩ ±0% SRD 1/4P
R322	0129609	CF 2.2KΩ ±5% SRD 1/4P
R323	0129661	CF 100KΩ ±5% SRD 1/4P
R325	0129617	CF 4.7KΩ ±5% SRD 1/4P
R326	0129617	CF 4.7KΩ ±5% SRD 1/4P
R327	0129631	CF 10KΩ ±5% SRD 1/4P
R328	0129611	CF 2.7KΩ ±5% SRD 1/4P (for W. Germany)
R329	0129661	CF 100KΩ ±5% SRD 1/4P
R330	0129661	CF 100KΩ ±5% SRD 1/4P
R331	0129645	CF 39KΩ ±5% SRD 1/4P
R332	0129631	CF 10KΩ ±5% SRD 1/4P (for W. Germany)
R332	0129633	CF 12KΩ ±5% SRD 1/4P (except U.S.A., Canada & W. Germany)
R332	0129635	CF 15KΩ ±5% SRD 1/4P (for U.S.A. & Canada)
R333	0129631	CF 10KΩ ±5% SRD 1/4P (for W. Germany)
R333	0129633	CF 12KΩ ±5% SRD 1/4P (except U.S.A., Canada & W. Germany)
R333	0129635	CF 15KΩ ±5% SRD 1/4P (for U.S.A & Canada)
R351	0129615	CF 3.9KΩ ±5% SRD 1/4P (except W. Germany)
R351	0129635	CF 15KΩ ±5% SRD 1/4P (for W. Germany)
R352	0129637	CF 18KΩ ±5% SRD 1/4P (for France & U.K)
R352	0129643	CF 33KΩ ±5% SRD 1/4P (for U.S.A. & Canada)
R352	0129649	CF 56KΩ ±5% SRD 1/4P (for W. Germany)
R353	0129661	CF 100KΩ ±5% SRD 1/4P
R354	0129561	CF 100Ω ±5% SRD 1/4P
R355	0129631	CF 10KΩ ±5% SRD 1/4P
R356	0129637	CF 18KΩ ±5% SRD 1/4P
R357	0129645	CF 39KΩ ±5% SRD 1/4P
R358	0129607	CF 1.8KΩ ±5% SRD 1/4P
R359	0129661	CF 100KΩ ±5% SRD 1/4P
R360	0129661	CF 100KΩ ±5% SRD 1/4P
R361	0129645	CF 39KΩ ±5% SRD 1/4P
R362	0129661	CF 100KΩ ±5% SRD 1/4P
R363	0129615	CF 3.9KΩ ±5% SRD 1/4P
R401LR	0129607	CF 1.8KΩ ±5% SRD 1/4P
R402LR	0129673	CF 330KΩ ±5% SRD 1/4P
R403LR	0129649	CF 56KΩ ±5% SRD 1/4P
R404LR	0129581	CF 680Ω ±5% SRD 1/4P
R405LR	0129675	CF 390KΩ ±5% SRD 1/4P
R406LR	0129643	CF 33KΩ ±5% SRD 1/4P

SYMBOL NO.	PART NO.	DESCRIPTION
R407LR	0129661	CF 100KΩ ±5% SRD 1/4P
R408LR	0129581	CF 680Ω ±5% SRD 1/4P
R409LR	0129581	CF 680KΩ ±5% SRD 1/4P
R411	0129669	CF 220KΩ ±5% SRD 1/4P
R412	0129621	CF 6.8KΩ ±5% SRD 1/4P
R413	0129647	CF 47KΩ ±5% SRD 1/4P
R416LR	0129581	CF 680Ω ±5% SRD 1/4P
R417	0129601	CF 1KΩ ±5% SRD 1/4P
R418	0129601	CF 1KΩ ±5% SRD 1/4P
R419	0129601	CF 1KΩ ±5% SRD 1/4P
R420	0129601	CF 1KΩ ±5% SRD 1/4P
R421	0129601	CF 1KΩ ±5% SRD 1/4P
R501	0129601	CF 1KΩ ±5% SRD 1/4P
R502	0129631	CF 10KΩ ±5% SRD 1/4P
R503	0129581	CF 680Ω ±5% SRD 1/4P
R504	0129605	CF 1.5KΩ ±5% SRD 1/4P
R505	0129537	CF 18Ω ±5% SRD 1/4P
R506	0129661	CF 100KΩ ±5% SRD 1/4P
R507	0129649	CF 56KΩ ±5% SRD 1/4P
R508	0129661	CF 100KΩ ±5% SRD 1/4P
R509	0129631	CF 10KΩ ±5% SRD 1/4P
R511	0129709	CF 2.2MΩ ±5% SRD 1/4P (for W. Germany)
R519	0129631	CF 10KΩ ±5% SRD 1/4P
R520	0129631	CF 10KΩ ±5% SRD 1/4P
R521	0129647	CF 47KΩ ±5% SRD 1/4P
R522	0129661	CF 100KΩ ±5% SRD 1/4P
R523	0129641	CF 27KΩ ±5% SRD 1/4P
R524	0129547	CF 47Ω ±5% SRD 1/4P
R525	0129601	CF 1KΩ ±5% SRD 1/4P
R526	0129565	CF 150Ω ±5% SRD 1/4P
R527	0129527	CF 390Ω ±5% SRD 1/4P
R528	0129613	CF 3.3KΩ ±5% SRD 1/4P
R529	0129619	CF 5.6KΩ ±5% SRD 1/4P
R530	0129631	CF 10KΩ ±5% SRD 1/4P
R531	0129661	CF 100KΩ ±5% SRD 1/4P
R532	0129661	CF 100Ω ±5% SRD 1/4P
R533	0129661	CF 100KΩ ±5% SRD 1/4P
R535	0129601	CF 1KΩ ±5% SRD 1/4P
R536	0129601	CF 1KΩ ±5% SRD 1/4P
R537	0129601	CF 1KΩ ±5% SRD 1/4P
R539	0129631	CF 10KΩ ±5% SRD 1/4P
R540	0129623	CF 8.2KΩ ±5% SRD 1/4P (for W. Germany)
R540	0129631	CF 10KΩ ±5% SRD 1/4P (except W. Germany)
R543	0129669	CF 220KΩ ±5% SRD 1/4P (for Asia & Latin American countries)
R544	0129669	CF 220KΩ ±5% SRD 1/4P (for Asia & Latin American countries)
R601LR	0129617	CF 4.7KΩ ±5% SRD 1/4P
R604LR	0129631	CF 10KΩ ±5% SRD 1/4P
R701LR	0129609	CF 2.2KΩ ±5% SRD 1/4P
R702LR	0129653	CF 82KΩ ±5% SRD 1/4P
R703LR	0129579	CF 560Ω ±5% SRD 1/4P
R704LR	0129653	CF 82KΩ ±5% SRD 1/4P
R705LR	0129605	CF 1.5KΩ ±5% SRD 1/4P
R707LR	9129633	CF 12KΩ ±5% SRD 1/4P
R708LR	0129621	CF 6.8KΩ ±5% SRD 1/4P
R709LR	0129653	CF 82KΩ ±5% SRD 1/4P
R710LR	0129577	CF 39Ω ±5% SRD 1/4P

# HITACHI HTA-25F

CD.... Ceramic Discal  
CC.... Cylindrical Ceramic

EL.... Electrolytic  
MF.... Mylar Film

SP.... Super Capacitors  
CF.... Carbon Film

ME... Metal  
MO.. Metal, Oxide

CO ... Composition  
FR .... Fuse Resistor

SYMBOL NO.	PART NO.	DESCRIPTION
R712LR	0129609	CF 2.2KΩ ±5% SRD 1/4P
R713LR	0129609	CF 2.2KΩ ±5% SRD 1/4
R714LR	0129609	CF 2.2KΩ ±5% SRD 1/4P
R715	0110621	FR 100Ω ±5% SRD 1/4B
R716	0129607	CF 1.8KΩ ±5% SRD 1/4P
R717	0139379	CO 3.3KΩ ±5% RC 1/2GF
R719LR	0119139	ME 4.7KΩ ±10% RN 2B
R720LR	0134366	CO 270Ω ±10% RC 1/2GF
R721	0110605	FR 22Ω ±5% RN 1/4B
R722	0129639	CF 22KΩ ±5% SRD 1/4P
R725	0129561	CF 100Ω ±5% SRD 1/4P
R726	0129643	CF 33KΩ ±5% SRD 1/4P
R727	0129635	CF 15KΩ ±5% SRD 1/4P
R728	0129661	CF 100KΩ ±5% SRD 1/4P
R735LR	0129531	CF 10Ω ±5% SRD 1/4P (for W. Germany)
R801	0129605	CF 1.5Ω ±5% SRD 1/4P
R802	0129605	CF 1.5Ω ±5% SRD 1/4P
R803	0119511	ME 68Ω ±10% RN 2B
R804	0129609	CF 2.2KΩ ±5% SRD 1/4P
R805	0129609	CF 2.2KΩ ±5% SRD 1/4P
R806	0123625	FR 220KΩ ±5% RN 1/4B
R807	0129607	CF 1.8KΩ ±5% SRD 1/4P
R808	0129605	CF 1.5KΩ ±5% SRD 1/4P
R809	0129601	CF 1KΩ ±5% SRD 1/4P
R810	0129605	CF 1.5KΩ ±5% SRD 1/4P
R811	0129617	CF 4.7KΩ ±5% SRD 1/4P
R812	0129630	FR 560Ω ±5% RN 1/4B
R813	0129635	FR 1.5KΩ ±5% SRD 1/4P
R814	0129617	CF 4.7KΩ ±5% SRD 1/4P
R815	0129635	CF 15KΩ ±5% SRD 1/4P
R816	0129617	CF 4.7KΩ ±5% SRD 1/4P
R817	0129603	CF 1.2KΩ ±5% SRD 1/4P
R818	0119541	ME 1KΩ ±10% RN 2B
R819	0134374	CO 12KΩ ±5% RC 1/2GF

## ICS & TRANSISTORS

IC201	2368431	AN278
IC202	2387321	AN7273
IC301	2367271	HA1196
IC401	2387301	M5218P
IC402	2387563	TC9151P
IC501	2368741	μPB553AC
IC502	2387421	AN6873N
IC503	2369031	μPD1703C-018
IC701	2387531	STK4141-II
Q151	2328652	2SC1740LN(S)
Q201	2328652	2SC1740LN (S)
Q302	2329183	2SA1015 (GR)
Q351	2328652	2SC1740LN (S)
Q352	2328652	2SC1740LN (S)
Q353	2328652	2SC1740LN (S)
Q354	2328652	2SC1740LN (S)
Q355	2329183	2SA1015 (GR)
Q356	2328652	2SC1740LN (S)
Q357	2328652	2SC1740LN (S)
Q501	2328653	2SC1740LN (E)
Q502	2328653	2SC1740LN (E)
Q503	2329183	2SA1015 (GR)
Q504	2328652	2SC1740LN (S)
Q511	2329183	2SA1015 (GR) (except U.S.A & Canada)
Q512	2328652	2SC1740LN (S)

SYMBOL NO.	PART NO.	DESCRIPTION
(except U.S.A & Canada)		
Q513	2328652	2SC1740LN (S)
Q514	2329183	2SA1015 (GR)
Q515	2329183	2SA1015 (GR)
Q516	2329183	2SA1015 (GR)
Q527	2329183	2SA1015 (GR) (for W. Germany, Asia & Latin American countries)
Q701	2328652	2SC1740LN (S)
Q801	2317822	2SD880 (Y)
Q802	2328652	2SC1740LN (S)
Q803	2329183	2SA1015 (GR)
Q804	2329183	2SA1015 (GR)

## DIODES

D101	2337601	1S2473
D102	2337601	1S2473
D151	2339921	KV1236
D152	2337601	1S2473
D153	2337601	1S2473
D154	2337601	1S2473
D301	2337601	1S2473
D302	2337601	1S2473
D303	2337601	1S2473
D304	2337601	1S2473
D305	2337601	1S2473
D351	2337601	1S2473
D352	2337601	1S2473
D401	2337601	1S2473
D402	2337601	1S2473
D403	2337601	1S2473
D501	2337601	1S2473
D506	2337601	1S2473
D507	2337601	1S2473
D508	2337601	1S2473
D509	2337601	1S2473
D510	2337601	1S2473
D514	2337601	1S2473
D515	2337601	1S2473
D516	2337601	1S2473
D517	2337601	1S2473
D518	2338871	1SLP-154B (RED)
D519	2338871	1SLP-154B (RED)
D520	2338871	1SLP-154B (RED)
D521	2337601	1S2473
D522	2337601	1S2473
D523	2337601	1S2473
D524	2337601	1S2473
D525	2337601	1S2473
D526	2337601	1S2473
D527	2337601	1S2473
D528	2337601	1S2473
D531	2337189	HZ15-3
D532	2337189	HZ15-3
D533	2337189	HZ15-3
D534	2337189	HZ15-3
D535	2337189	HZ15-3
D702	2337601	1S2473
D801	2337461	S4VB20
D802	2337762	ERB12-01
D803	2337569	HZ12C-3

SYMBOL NO.	PART NO.	DESCRIPTION
D804	2337189	HZ15-3
D805	2337189	HZ15-3
D806	2337519	HZ6-C3
D807	2337601	1S2473
D808	2337601	1S2473
D810	2337762	ERB12-1
D811	2337762	ERB12-1
D812	2337188	HZ24-2
D813	2337549	HZ7-C3

## VARIABLE RESISTORS

R303	0150958	10KΩ - (B)
R602	0166713	200KΩ - (W) (VALANCE)
R605LR	0166851	100KΩ - (B) (VOLUME)
R706LR	0166852	50KΩ - (B) (TONE)
R711LR	0166852	50KΩ - (C) (TONE)

## COILS & TRANSFORMERS

L301	2227394	Choke coil (2.2 μH) (for W. Germany)
L701LR	2227291	Audio trap coil (for W. Germany)
T151	2136503	MW RF coil
T152	2136493	MW OSC coil
T201	2154493	AM IF trans.
T202	2155173	FM discri. coil

## MISCELLANEOUS

CT151	0283126	Trimmer capacitor 11P
CP201	02134931	Anti-birdy filter (for W. Germany)
CP501	0241892	Capacitor array (330pF × 7)
	2425491	FM Tuner pack (except W. Germany)
	2425492	FM Tuner pack (for W. Germany)
	2678345	8P US pin jack
	2688203	5P screw terminal (for U.S.A., Canada & France)
	2688204	5P screw terminal (for U.S.A & Canada)
	2689381	4P push terminal
	4567411	3ø × 6 DT bind screw
	4784106	3ø × 10 bind tapping screw
	4573552	2ø × 16 bind tapping screw
	2677646	Head phono jack (except U.S.A)
	2677648	Head phono jack (for U.S.A)
	2788622	Fluorescent display tube
MF201	2134982	FM Ceramic filter MA5 (for U.S.A., Canada & France)
MF201	2135002	FM Ceramic filter MS2 (except U.S.A., Canada & France)
MF202	2134982	FM Ceramic filter MA5 (for U.S.A., Canada & France)
MF202	2135002	FM Ceramic filter MS2 (for U.S.A., Canada & France)
MF203	2155152	AM Ceramic filter 450F3
MF204	2135002	FM Ceramic filter MS2





**HITACHI SALES CORPORATION OF AMERICA**  
**Eastern Regional Office**

1200 Wall Street West, Lyndhurst, New Jersey  
07071, U.S.A.

Tel. 201-935-8980

**Mid-Western Regional Office**

1400 Morse Ave., Elk Grove Village, Ill. 60007, U.S.A.  
Tel. 312-593-1550

**Southern Regional Office**

510 Plaza Drive College Park, Georgia 30349, U.S.A.  
Tel. 404-763-0360

**Western Regional Office**

401 West Artesia Boulevard, Compton, California  
90220, U.S.A.

Tel. 213-537-8383

**HITACHI SALES CORPORATION OF HAWAII, INC.**

3219 Koapaka Street Honolulu, Hawaii 96819, U.S.A.  
Tel. 808-836-3621

**HITACHI (HSC) CANADA INC.**

3300 Trnas Canada Highway, Pointe Claire, Quebec  
H9RU 1B1, Canada

Tel. 514-697-9150

**HITACHI SALES EUROPA GmbH**

2050 Hamburg 54, Rungedamm 2, West Germany  
Tel. 73411-0

**HITACHI SALES (U.K.) Ltd.**

Hitachi House, Station Road, Hayes, Middlesex UB3  
4DR, England

Tel. 01-848-8787 (Service Centre: 01-848-3551)

**HITACHI SALES SCANDINAVIA AB**

Rissneleden 8, Box 7138, 172-07 Sundbyberg,  
Sweden

Tel. 08-98 52 80

**HITACHI SALES NORWAY A/S**

Oerebekk 1620 Gressvik P.O. Box 46 N-1601  
Fredrikstad, Norway

Tel. 032-28255

**SUOMEN HITACHI OY**

Takojankatsu 5, 15800 Lahti 80, Finland  
Tel. Lahti 44 241

**HITACHI SALES A/S**

Kuldysen 13, DK-2630 Taastrup, Denmark  
Tel. 02-999200

**HITACHI SALES A.G.**

Bahnhofstrasse, 19, 5600 Lenzburg  
Switzerland

Tel. 046-513621

**HITACHI FRANCE S.A.**

97/115 Rue Charles-Michels 93200  
SAINT-DENIS, France

Tel. 201-25-00

**HITACHI SALES WARENHANDELS GMBH**

A-1180/Wien, Kreuzgasse 27, Austria  
Tel. (0222) 43936/8

**HITACHI SALES BELGIUM S.A./N.V.**

56, Chaussee de Namur, B-1400  
Nivelles, Belgium

Tel. (067) 22 7181

**HITACHI SALES AUSTRALIA Pty Ltd.**

153 Keys Road, Moorabbin, Victoria 3189, Australia  
Tel. 555-8722

**HITACHI Ltd. TOKYO JAPAN**

Head Office: THE HITACHI ATAGO BLDG.

No. 15-12, 2-chome Nishi-Shinbashi  
Minato-ku, Tokyo 105, Japan  
Tel. Tokyo (03) 502-2111

**HTA-25F TY No. 409 EGF**