

SERVICE MANUALEnglish
Deutsch
Français

No.208

**FEATURES**

- Tuner Section
 1. Microcomputer-controlled digital synthesizer tuner with 6 FM and 6 AM preset stations
 2. Signal indicators
 3. High Quality FM Tuner Front-End
 4. Phase-Locked Loop for FM/MPX Circuit
 5. Birdie filter
 6. Memory back-up
 7. AM Loop Antenna
- Audio section
 1. DC main amplifier with Super Linear Circuit and high transition frequency transistors
 2. Equalizer circuit with HA12017 monolithic IC featuring high dielectric strength and low noise
 3. Dual-system tape monitor function
 4. Subsonic Filter
 5. Electronic Protection Circuit
 6. Connection Facilities for Two Speaker Systems
- Design
 1. Switches with indicators
 2. Sub panel

MERKMALE

- Tuner-Teil
 1. Mikrocomputergesteuerter Digital-Synthesizer-Tuner mit 6 UKW- und 6 MW-Sendertasten
 2. Feldstärkeanzeigen
 3. UKW-Tuner-Engangsstufe mit hoher Qualität
 4. PLL-Schaltkreis für UKW/Stereo-Schaltung
 5. Intermodulationsfilter
 6. Memory-Sicherungssystem
 7. MW-Rahmenantenne
- Audio-teil
 1. Gleichstrom-Endverstärker mit superlinearen Schaltkreisen und Transistoren mit hoher Übergangsfrequenz
 2. Entzerrungsschaltkreis mit monolithischem IC HA12017 hoher dielektrischer Stärke und geringer Verzerrungen
 3. Zweifache Bandmithörkontrolle
 4. Subsonic-Filter
 5. Elektronische Schutzschaltung
 6. Anschlußeinrichtungen für zwei Lautsprechersysteme
- Design
 1. Schalter mit Anzeigen
 2. Zwischenfrontplatte

CARACTERISTIQUES

- Section Tuner
 1. Tuner synthétiseur numérique contrôlé par micro-ordinateur et possibilité de préréglage 6 stations FM et 6 AM
 2. Indicateurs de signal
 3. Premier étage de tuner FM de haute qualité
 4. Boucle à verrouillage de phase pour circuit FM/MPX
 5. Filtre des sifflements
 6. Alimentation d'appoint pour la mémoire
 7. Antenne-cadre AM
- Section audio
 1. Amplificateur principal DC avec circuit Super-linéaire et transistors à haute fréquence de transition
 2. Circuit correcteur avec circuit intégré monolithique HA12017 à haute rigidité diélectrique et faible bruit
 3. Fonction de contrôle de bande pour deux magnétophones
 4. Filtre subsonique
 5. Circuit électronique de protection
 6. Branchements possibles pour deux systèmes d'enceintes
- Construction
 1. Commutateurs à témoins
 2. Panneau auxiliaire

STEREO TUNER AMPLIFIER**September 1980**

SPECIFICATIONS

• FM SECTION	
Frequency range	Europe: 87.50 — 108.00 MHz U.S.A.: 87.9 — 107.9 MHz
Usable sensitivity	Mono: 1.0 μ V (75 ohms, IHF and DIN) 10.8 dBf (new IHF 300 ohms)
50 dB quieting sensitivity	Mono: 16.2 dBf (3.6 μ V)
Signal-to-noise ratio (at 65 dBf)	Mono: 75 dB (IHF) 72 dB (DIN)
Total harmonic distortion (at 65 dBf)	
1 kHz	
Frequency response	Mono: 0.1% 30 Hz — 15 kHz \pm 1 dB
Image rejection ratio	98 MHz: 75 dB
Spurious response ratio	90 dB
IF rejection ratio	90 dB
Selectivity	70 dB (\pm 400 kHz IHF) 65 dB (\pm 300 kHz DIN)
Capture ratio	1 dB
AM suppression ratio	55 dB
Stereo separation	45 dB (1 kHz)
Subcarrier suppression	40 dB
SCA rejection ratio	50 dB
Muting threshold	20 dBf (5.5 μ V)
Antenna input	300 ohms balanced, 75 ohms unbalanced
• AM SECTION	
Frequency range	Europe: 522 — 1,611 kHz U.S.A.: 530 — 1,620 kHz
Sensitivity	15 μ V (IHF, ext. Antenna), 400 μ V/m (Loop)
Image rejection ratio	50 dB
Selectivity	30 dB (IHF \pm 10 kHz) 28 dB (DIN \pm 9 kHz)
Signal-to-noise ratio (at 50 mV)	50 dB
Antenna	Loop antenna and separate terminal
• AUDIO SECTION	
Output	
RMS Power	
(Both channels driven)	
	55 Watts per channel, min. RMS, at 8 ohms from 20 Hz to 20 kHz, with no more than 0.02% total harmonic distortion.
	55 W + 55 W (8 ohms, 1 kHz, T.H.D. 0.02% IHF and DIN)
	55 W + 55 W (4 ohms, 1 kHz, T.H.D. 0.02% IHF)
	55 W + 55 W (4 ohms, 1 kHz, T.H.D. 0.02% DIN)
	10 Hz — 60 kHz (1/2 RMS power, T.H.D. 0.05% at 8 ohms)
	5 Hz — 70 kHz \pm 1 dB
Power bandwidth	
Frequency characteristics	
Total harmonic distortion	
(at rated output)	Less than 0.02%
Intermodulation distortion	
(at 1/2 rated output)	0.02%
Input sensitivity	
(at 55 W output, 1 kHz)	
PHONO	2.5 mV (47 k-ohms)
TAPE	150 mV (47 k-ohms)
Max. input level (PHONO)	200 mV (T.H.D. 0.02% at 1 kHz)
Output level	
TAPE OUT	150 mV (PHONO at rated input) 150 mV (FM 400 Hz, 30% dev. input: 1 mV) 150 mV (AM 400 Hz, 30% mod. input: 5 mV/m)
Signal-to-noise ratio	
(IHF, A network, rated power)	
PHONO	80 dB
TAPE	100 dB
Damping factor	50 (1 kHz, 8 ohms)
Equalizer	RIAA \pm 0.3 dB
Bass control	\pm 9 dB (100 Hz)
Treble control	\pm 8 dB (10 kHz)
Loudness control	+6 dB (100 Hz), +4 dB (10 kHz)
Subsonic filter	-12 dB/oct. (20 Hz)
FM Muting	Provided
Tape monitor	2
LED indicators	Signal 5 LEDs, Preset 6 LEDs, Memory 1 LED, Function 4 LEDs, Tape 2 LEDs, Power 1 LED
Speaker switch	A, B
AC outlet	1 (50 W switched), 1 (100 W unswitched) (for U.S.A., Canada and some other countries)
Power requirements	AC 120 V 60 Hz, \sim 220 V 50/60 Hz, \sim 240 V 50/60 Hz or \sim 120 V/220 V/240 V 50/60 Hz
Power consumption	220 W (at 1/3 rated output), 370 W (at rated output)
Dimensions	435 (W) x 110 (H) x 386 (536) (D) mm () Loop Antenna Open 17-1/8 (W) x 4-5/16 (H) x 15-3/16 (21-3/32) (D) in.
Weight	8.4 kg

Specifications and design may be changed without notice for improvement.

TECHNISCHE DATEN

• FM-TEIL	
Empfangsbereich	Europa: 87,50 MHz bis 108,00 MHz USA: 87,9 MHz bis 107,9 MHz
Nutzempfindlichkeit	Mono: 1,0 μ V (75 Ohm, IHF und DIN) 10,8 dBf (neue IHF 300 Ohm)
Grenzempfindlichkeit (bei 50 dB)	Mono: 16,2 dBf (3,6 μ V)
Fremdspannungsabstand (bei 65 dBf)	Mono: 75 dB (IHF) 72 dB (DIN)
Klirrfaktor (bei 65 dBf)	
1 kHz	Mono: 0,1%
Frequenzgang	30 Hz — 15 kHz \pm 1 dB
Spiegelfrequenzdämpfung	98 MHz: 75 dB
Zwischenfrequenzdämpfung	90 dB
Nebenwellendämpfung	90 dB
Selektivität	70 dB (\pm 400 kHz IHF) 65 dB (\pm 300 kHz DIN)
Übernahmeverhältnis	1 dB
AM-Unterdrückung	55 dB
Stereotrennung	45 dB (1 kHz)
Hilfsträgerdämpfung	40 dB
SCA-Sperre	50 dB
Ansprechschwelle für Geräuschsperre	20 dBf (5,5 μ V)
Antenneneingang	300 Ohm symmetrisch, 75 Ohm asymmetrisch
• AM-TEIL	
Frequenzbereich	Europa: 522 — 1 611 kHz USA: 530 — 1 620 kHz
Empfindlichkeit	15 μ V (IHF, ext. Antenne), 400 μ V/m (Rahmenantenne)
Spiegelaperte	50 dB
Trennschärfe	30 dB (IHF \pm 10 kHz) 28 dB (DIN \pm 9 kHz)
Signal/Rausch-Abstand (bei 50 mV)	50 dB
Antenne	MW-Zimmerantenne und Separatanschluß
• AUDIO-TEIL	
Ausgangleistung	55 W + 55 W (an 8 Ohm, 20 Hz — 20 kHz, Klirrgrad 0,02%) 55 W + 55 W (an 8 Ohm, 1 kHz, Klirrgrad 0,02% IHF und DIN) 55 W + 55 W (an 4 Ohm, 1 kHz, Klirrgrad 0,02% IHF) 55 W + 55 W (an 4 Ohm, 1 kHz, Klirrgrad 0,02% DIN) 10 Hz — 60 kHz (1/2 RMS-Sinusleistung, T.H.D. 0,05% bei 8 Ohm) 5 Hz — 70 kHz \pm 1 dB
Leistungsbandbreite	
Frequenzcharakteristiken	
Klirrfaktor	
(bei Nennleistung)	Weniger als 0,02%
Intermodulationsverzerrung	
(bei 1/2 Nennleistung)	0,02%
Eingangsempfindlichkeit	
(bei 55 W Abgabeleistung, 1 kHz)	
PHONO	2,5 mV (47 kOhm)
Band (TAPE)	150 mV (47 kOhm)
Max. Eingangspegel (PHONO)	200 mV (T.H.D. 0,02% bei 1 kHz)
Ausgangspegel	
Tonband-Ausgang (TAPE OUT)	150 mV (PHONO bei Nennleistung) 150 mV (FM 400 Hz, 30% Abw. Eingang: 1 mV) 150 mV (AM 400 Hz, 30% Mod. Eingang: 5 mV/m)
Geräuschspannungsabstand	
(IHF, A Netz, Nennleistung)	
PHONO	80 dB
TAPE	100 dB
Dämpfungsfaktor	50 (1 kHz, 8 Ohm)
Entzerrer	RIAA \pm 0,3 dB
Baßregler	\pm 9 dB (100 Hz)
Höhenregler	\pm 8 dB (10 kHz)
Gehörrichtige Lautstärkeregelung	+6 dB (100 Hz), +4 dB (10 kHz)
Infraschallfilter	-12 dB/Okt. (20 Hz)
FM Dämpfung	Vorhanden
Hinterbandkontrolle	2
LED-Anzeigen	Feldstärke 5 LED, Voreinstellung 6 LED, Speicher 1 LED, Funktion 4 LED, Tonband 2 LED, Strom 1 LED
Lautsprecherschalter	A, B
Wechselstromanschluß	1 (50 W geschaltet), 1 (100 W ungeschaltet) (für USA, Kanada und einige andere Länder)
Strombedarf	Wechselstrom 120 V 60 Hz, \sim 220 V 50/60 Hz, \sim 240 V 50/60 Hz oder \sim 120 V/220 V/240 V 50/60 Hz
Stromverbrauch	220 W (bei 1/3 Nennleistung) 370 W (bei Nennleistung)
Abmessungen	435 (B) x 110 (H) x 386 (536) (T) mm () Rahmenantenne, offen
Gewicht	8,4 kg

Änderungen der technischen Daten bleiben im Sinne der ständigen Verbesserung vorbehalten.

CARACTERISTIQUES TECHNIQUES

• SECTION FM

Bande de fréquences

Europe: 87,50 — 108,00 MHz

U.S.A.: 87,9 — 107,9 MHz

Sensibilité utilisable

Mono: 1,0 μ V (75 ohms, IHF et DIN)
10,8 dBf (nouvelle IHF 300 ohms)

Seuil de sensibilité 50 dB

Mono: 16,2 dBf (3,6 μ V)

Stéréo: 38,2 dBf (44,6 μ V)

Rapport signal/bruit (65 dBf)

Mono: 75 dB (IHF)
72 dB (DIN)

Stéréo: 72 dB (IHF)
68 dB (DIN)

**Distorsion harmonique (65 dBf)
1 kHz**

Mono: 0,1%

Stéréo: 0,2%

Réponse en fréquence

30 Hz — 15 kHz $\pm 1/2$ dB

Rapport de réjection image

98 MHz: 75 dB

Rapport de réception non sélective

90 dB

Taux de réjection FI

90 dB

Sélectivité

70 dB (± 400 kHz IHF)

65 dB (± 300 kHz DIN)

Rapport de captage

1 dB

Taux de suppression AM

55 dB

Séparation stéréo

45 dB (1 kHz)

Filtrage de la sous-porteuse

40 dB

Taux de réjection SCA

50 dB

Seuil de sourdine

20 dBf (5,5 μ V)

Entrée de l'antenne

300 ohms pondérés, 75 ohms non-équilibrés

• SECTION AM

Bande de fréquence

Europe: 522 — 1 611 kHz

U.S.A.: 530 — 1 620 kHz

Sensibilité

15 μ V (Antenne ext., IHF), 400 μ V/m (Cadre)

Taux de réjection image

50 dB

Sélectivité

30 dB (IHF ± 10 kHz) 28 dB (DIN ± 9 kHz)

Rapport signal/bruit (50 mV)

50 dB

Antenne

Antenne-cadre et borne séparée

• SECTION AUDIO

Sortie

55 W + 55 W (8 ohms, 20 Hz — 20 kHz, D.H.T. 0,02%)

55 W + 55 W (8 ohms, 1 kHz, D.H.T. 0,02% IHF et DIN)

55 W + 55 W (4 ohms, 1 kHz, D.H.T. 0,02% IHF)

55 W + 55 W (4 ohms, 1 kHz, D.H.T. 0,02% DIN)

10 Hz — 60 kHz (Puissance 1/2 RMS, D.H.T. 0,05% à 8 ohms.)

5 Hz — 70 kHz $\pm 1/2$ dB

Bande passante

Courbe de fréquence

Distorsion harmonique

Inférieure à 0,02%

(à la puissance réelle)

Distorsion d'intermodulation

0,02%

(à la moitié de la puissance réelle)

Sensibilité d'entrée

(sous 55 W, 1 kHz de sortie)

PHONO

2,5 mV (47 k ohms)

TAPE

150 mV (47 k ohms)

Niveau d'entrée maximum (PHONO)

200 mV (avec une D.H.T. de 0,02% à 1 kHz)

Niveau de sortie

150 mV (PHONO, à l'entrée nominale)

150 mV (FM 400 Hz, 30% d'entrée dév.: 1 mV)

150 mV (AM 400 Hz, 30% d'entrée mod.: 5 mV/m)

Rapport signal/bruit

(IHF, réseau A, puissance nominale)

PHONO

80 dB

TAPE

100 dB

Facteur d'atténuation

50 (1 kHz, 8 ohms)

Compensateur

RIAA $\pm 0,3$ dB

Commande des graves

± 9 dB (100 Hz)

Commande des aigus

± 8 dB (10 kHz)

Correction sonore physiologique

+6 dB (100 Hz), +4 dB (10 kHz)

Filtre infrasonique

-12 dB/oct. (20 Hz)

Sonorité FM

Incorporé

Contrôle de bande

2

LED indicatrices

Signal 5 LED, pré-réglage 6 LED, mémoire 1 LED, fonction 4 LED, bande 2 LED, alimenta-

tion 1 LED

Interrupteur d'enceintes

A, B

Sortie C.A.

1 (50 W commutable), 1 (100 W non commutable) (Pour les USA, le Canada et autres

pays)

Alimentation

C.A. 120 V 60 Hz, ~ 220 V 50/60 Hz, ~ 240 V 50/60 Hz ou

~ 120 V/220 V/240 V 50/60 Hz

Consommation

220 W (à 1/3 de la puissance réelle)

370 W (à la puissance réelle)

Dimensions

435 (L) x 110 (H) x 386 (536) (P) mm, () Antenne-cadre déployée

Poids

8,4 kg

Les caractéristiques techniques et la présentation peuvent être modifiées sans préavis pour des raisons d'améliorations.

DISASSEMBLY AND REPLACEMENT · ZERLEGUNG UND AUSTAUSCH · DEMONTAGE ET REMONTAGE

- Removing the upper cover, front panel & bottom plate
- Ausbau der oberen Abdeckung, der Fronttafel und der Bodenplatte
- Déposer le couvercle supérieur, le panneau avant et la plaque inférieure

(for U.S.A. & Canada)...Black
(except U.S.A. & Canada)...Silver

4φ x 8DT screw with washer
(Black or Silver)(x2)

4φ x 8DT screw with washer
(Black or Silver)(x2)

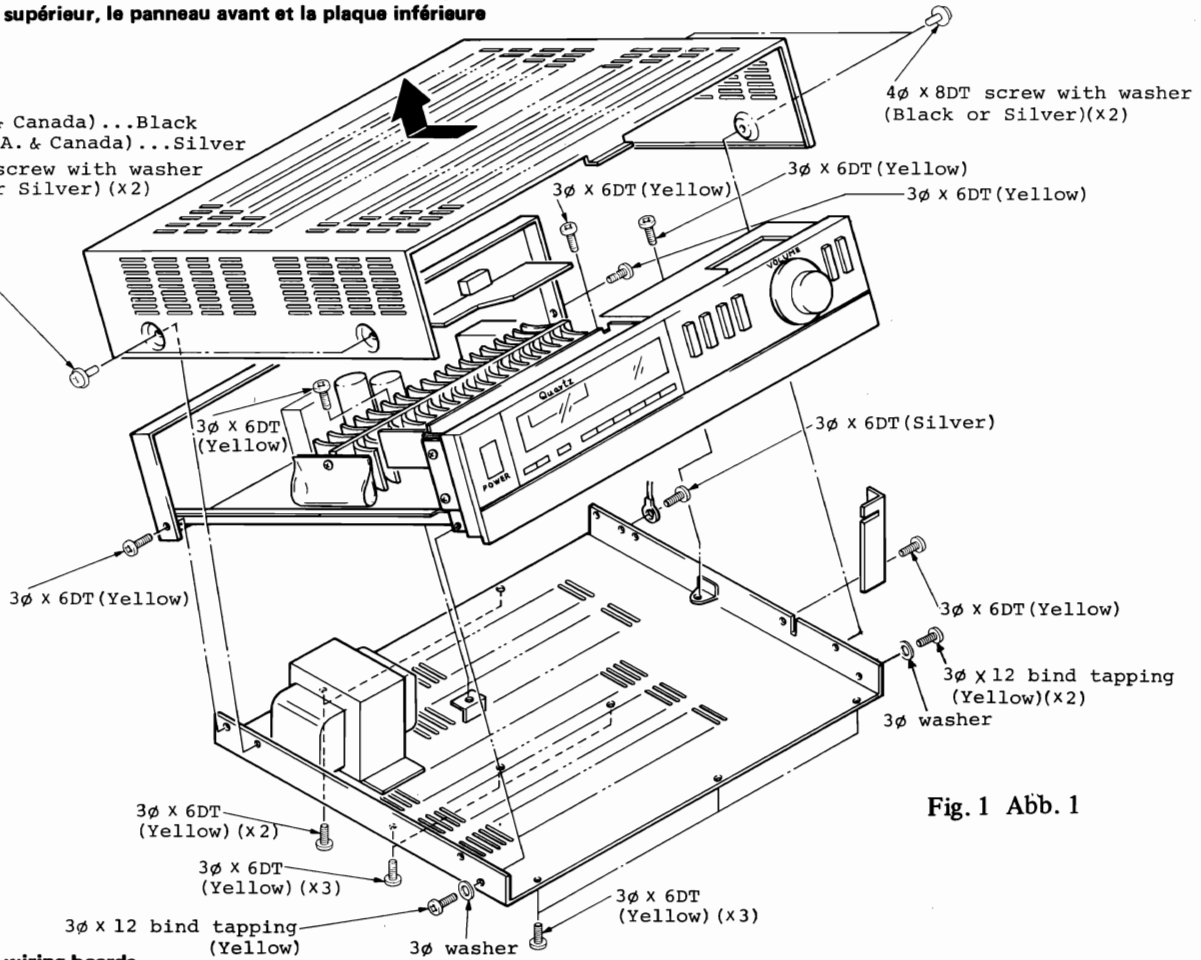

Fig. 1 Abb. 1

- Removing the printed wiring boards
- Ausbau der Leiterplatten
- Déposer des plaquettes à circuit imprimé

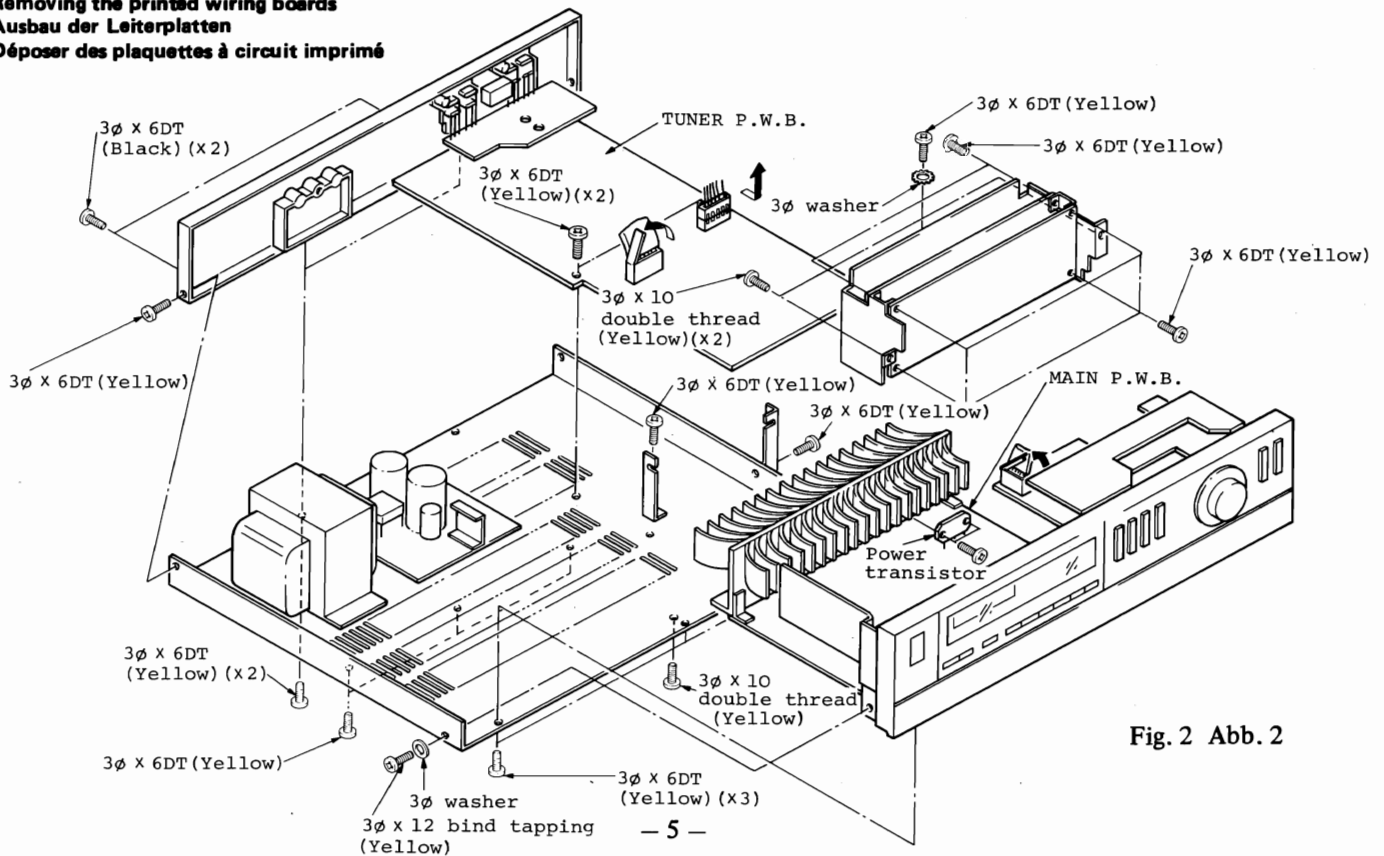

Fig. 2 Abb. 2

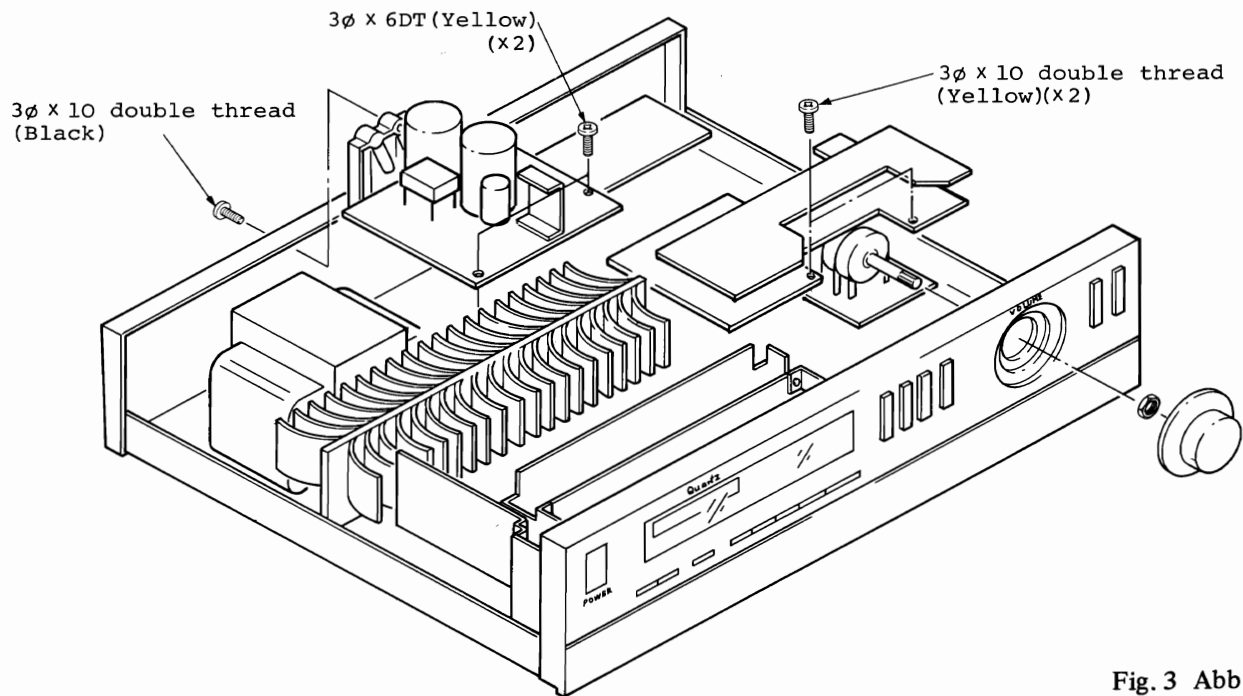

Fig. 3 Abb. 3

Caution:

Oscillations may occur when checking circuit voltage, especially when touching main amp. Q701, etc. with a tester. Remove the transistor and perform checking at this time.

Vorsicht:

Beim prüfen des Schaltkreises kann es zu Oszillationen kommen, besonders wenn der Hauptverstärker Q701 usw. mit der Probe des Prüfgerätes berührt wird. Den Transistor ausbauen und dann die Prüfung durchführen.

Attention:

Des oscillations peuvent se produire lors du contrôle de la tension du circuit, notamment lorsque l'ampli principal Q701 est touché avec un testeur. Effectuer le contrôle après avoir déposé le transistor.

GENERAL ALIGNMENT INSTRUCTION · ALLGEMEINE AUSRICHTANLEITUNG · INSTRUCTIONS GENERALES

- Tuner P.W.B.
- Tuner, gedruckte Schaltung
- Plaqueette imprimée de tuner

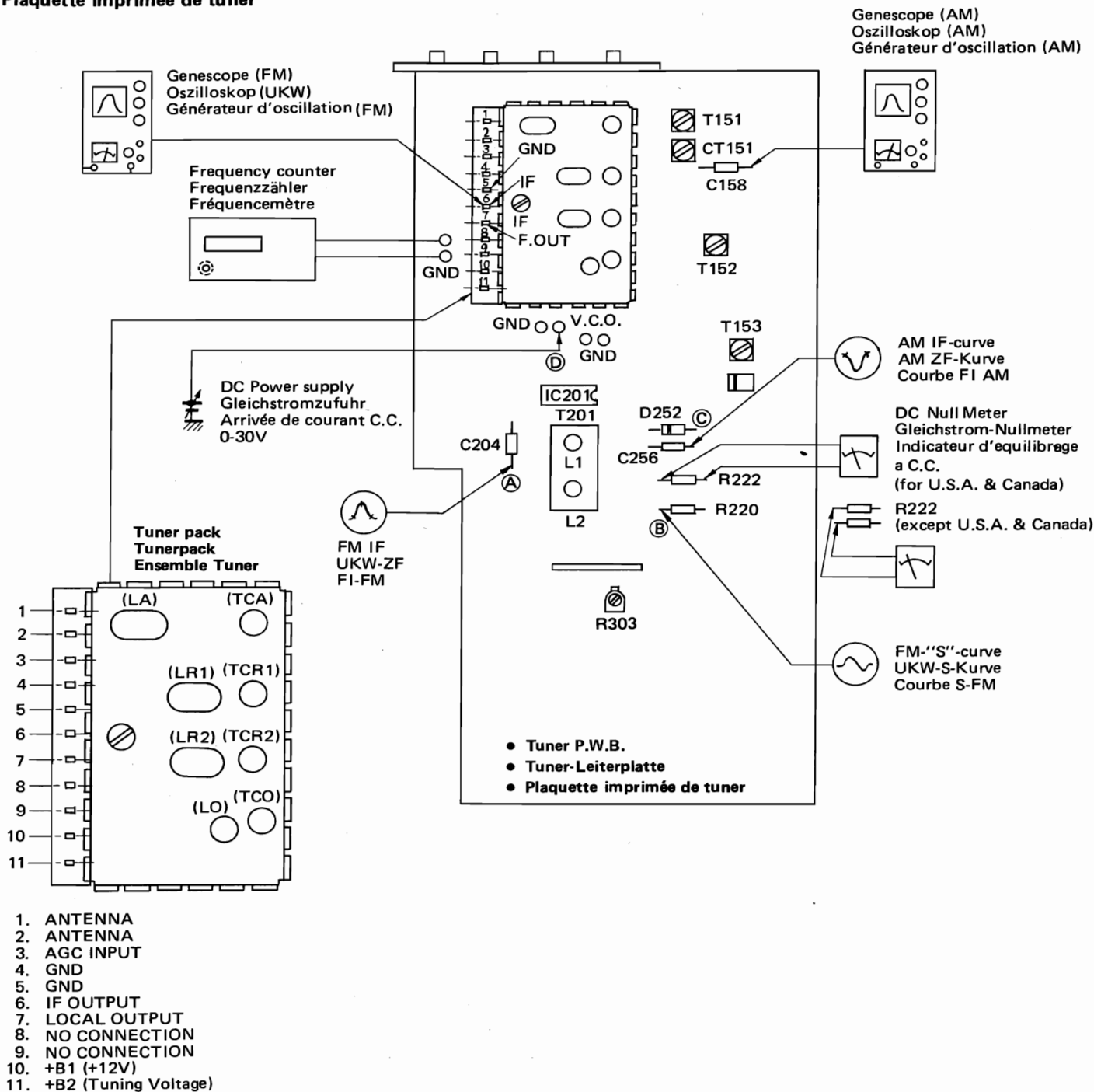



Fig. 4 Abb. 4

FM TUNER ALIGNMENT • ABGLEICH DES UKW-TUNERS • REGLAGE DE TUNER FM

 Sweep Generator
Wobbelgenerator
Générateur de balayage

 Signal Generator
Signalgenerator
Générateur de signaux



 Oscilloscope
Oszilloskop
Oscilloscope

 DC Null Meter
Gleichstrom-Nullmeter
Indicateur
d'équilibrage à C.C.

 VTVM
V.T.V.M.
Voltmètre électronique

 Frequency Counter
Frequenzzähler
Fréquencecetre

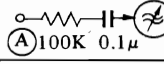
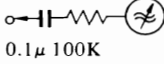
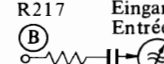
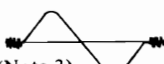
 Dist. Distortion Meter
Klirrnesser
Distorsionmètre

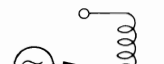
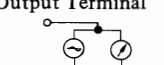
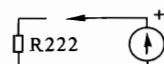
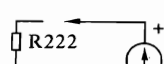
Sequence Folge Ordre	Connection Anschlüsse Connexion		Setting Einstellung Montage		Adjust for Einstellung für Réglage pour	
	Input Eingang Entrée	Output Ausgang Sortie	Tuning Abstimm- anzeige Indicateur d'accord	Signal Signal Signal	Adjust Einstellpunkt Réglage	Indication Indikation Indication
1	Tuner Pack	Tuner P.W.B. R209 IN Eingang Entrée 	—	10.7 MHz	IFT (Tuner Pack) (Tuner-Teil) (Ensemble Tuner)	(Note 2) (Hinweis 2)
2	IF ZF IF OUT Ausgang Sortie 	Tuner P.W.B. R217 IN Eingang Entrée 	—	10.7 MHz	T201 L1: "S" curve S-Kurve Courbe en forme de L2: Straight Line Gerade Linie Ligne droite	Straight line Gerade Linie Ligne droite  (Note 3) (Hinweis 3)
3	Covering Abstimmung Guipage	F.OUT Tuner pack (Tuner-Teil) (Ensemble Tuner) 	—	—	LO	98.20 MHz (Note 4) (Hinweis 4)
			—	—	TCO	118.70 MHz (Note 5) (Hinweis 5)
4	ANT. Terminal (300 ohms) 	Output Terminal 	90.1 or 90.00 MHz	90.1 or 90.00 MHz	LA, LR1, LR2	V max. (Note 6) (Hinweis 6)
		(for U.S.A. & Canada)	106.1 or 106.00 MHz	106.1 or 106.00 MHz	TCA, TCR1, TCR2	Repeat 5
5	Discriminator Diskriminator Discriminateur		98.1 or 98.00 MHz	98.1 or 98.00 MHz	T201 (L1)	(Note 7) (Hinweis 7)
6	Distortion Verzerrung Distorsion 1 kHz, 75 kHz (dev.) 60 dBμ (for U.S.A. Canada) 40 kHz (dev.) (except U.S.A. Canada)	(except U.S.A. & Canada) 	98.1 or 98.00 MHz	98.1 or 98.00 MHz	T201 (L2)	Distortion min. (Note 8) (Hinweis 8)
7	Separation Séparation ANT. Terminal (300 ohms) (L + R) 34.5 kHz Dev. (L - R) 34.5 kHz Dev. Pilot 6 kHz Dev. fm = 1 kHz (for U.S.A. and Canada) (L + R) 20 kHz Dev. (L - R) 20 kHz Dev. Pilot 6 kHz Dev. (except U.S.A. and Canada)	Output Terminal	98.1 or 98.00 MHz	98.1 or 98.00 MHz	R303	Cross talk MIN. Lch → Rch. Rch → Lch.

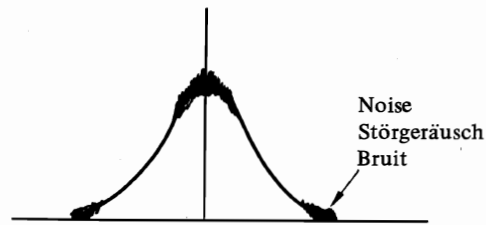

Fig. 5 Abb. 5

- (Note 1) Perform adjustment at least 3 minutes after the power has been switched on.
- (Note 2) Using a sweep generator, apply low-input signals (with a small amount of noise superimposed as in Fig. 5, and adjust the tuner pack's IFT so that the waveforms are brought to their maximum in center marker frequency (10.7 MHz).
- (Note 3) Adjust the T201-L1 coil and obtain an S-curve. Now adjust the T201-L2 coil and improve the linearity of the S-curve.
- (Note 4) Remove the hot wire of the shielded wire (D) and apply a 2.85 V DC voltage to pin (11) B2 in the TUNER PACK P.W.B., and adjust Lo so that the frequency of LOCAL OUT fed out to pin (7) F. out is brought to 98.20 MHz.
- (Note 5) Remove the hot wire of the shielded wire (D) and apply a 21.0 V DC voltage to pin (11) B2 in the TUNER PACK P.W.B., and adjust TCo so that the frequency of the LOCAL OUT fed out to pin (7) F. out is brought to 118.7 MHz.
- (Note 6) Reduce the output of the FM signal generator as the adjustments advance, and ultimately reduce so that noise is superimposed on the output waveforms (so that the limiter does not work).
- (Note 7) Connect a DC null meter across R222-R223 on the tuner P.W.B., and adjust T201-L1 core for a reading of 0 V \pm 60 mV.
- (Note 8) When the distortion adjustment is performed, there will be a slight deviation in the discriminator adjustment performed under 5. Therefore, repeat adjustments 5 and 6 several times and adjust for a reading of 0 V on the DC null meter with the distortion at its minimum.

- (Hinweis 1) Den Abgleich frühestens 3 Minuten nach dem Einschalten des Netzschalters durchführen.
- (Hinweis 2) Mit Hilfe eines Wobbelgenerators sind niederpegelige Signale (mit geringer Rauschstörung an der Anstiegsflanke der in Abb. 5) anzulegen; IFT des Tuner-TEils so abgleichen, daß Wellenform an der Mittenmarkierungsfrequenz (10,7 MHz) ein Maximum annimmt.
- (Hinweis 3) T201-L1 abgleichen, um eine S-Kurve zu erhalten. Danach die Spule T201-L2 nachjustieren, um die gerade Linie in der S-Kurve zu verbessern.
- (Hinweis 4) Den spannungsführenden Draht des abgeschirmten Kabels (D) abtrennen und eine Gleichspannung von 2,85 V an Stift (11) B2 der Tuner-Leiterplatte anlegen; Lo so abgleichen, daß die am Ausgang des Empfangsoszillators (LOCAL OUT) an Stift (7) F angelegte Frequenz 98,20 MHz annimmt.
- (Hinweis 5) Den spannungsführenden Draht des Kabels (D) abtrennen und eine Gleichspannung von 21,0 V an Stift (11) B2 der Tuner-Leiterplatte anlegen; TCo so abgleichen, daß die am Ausgang des Empfangsoszillators (LOCAL OUT) an Stift (7) F angelegte Frequenz 118,7 MHz annimmt.
- (Hinweis 6) Den Ausgang des FM-Signalgenerators langsam reduzieren, bis schließlich Rauschstörungen an der Ausgangswellenform auftreten (so daß der Begrenzer nicht mehr arbeitet).
- (Hinweis 7) Einen Gleichspannungsmesser an R222 und R223 anschließen (auf der Tuner-Leiterplatte) und T201-L1 auf eine Anzeige von 0 V \pm 60 mV einstellen.
- (Hinweis 8) Wenn der Verzerrungsabgleich vorgenommen wird, kommt es zu einer kleinen Änderung der in Punkt 5 durchgeführten Diskriminator-Einstellung. Die Abgleiche 5 und 6 sind daher mehrmals zu wiederholen, bis der Spannungsmesser bei minimalen Verzerrungen 0 V anzeigt.

- (Note 1) Effectuer ce réglage au moins 3 minutes après la mise sous tension.
- (Note 2) Utiliser un générateur de balayage et appliquer des signaux d'entrée à faible niveau (avec un faible chevauchement de bruit comme représenté sur la figure 5, et ajuster le transformateur de fréquence intermédiaire du groupe tuner pour amener les formes d'ondes à leur maximum de la fréquence nominale de repérage (10,7 MHz).
- (Note 3) Ajuster la bobine T201-L1 pour obtenir une courbe en forme de "S". Ajuster ensuite la bobine T201-L2 et améliorer la linéarité de la courbe en forme de "S".
- (Note 4) Débrancher le fil chaud du fil blindé (D) et appliquer une tension continue de 2,85V à la broche (11) B2 de la plaquette à circuits imprimés du groupe tuner et ajuster la basse tension pour que la fréquence de la sortie LOCAL OUT obtenue à la broche (7) F.OUT corresponde à 98,20 MHz.
- (Note 5) Débrancher le fil chaud du fil blindé (D) et appliquer une tension continue de 21,0 V à la broche (11) B2 de la plaquette à circuits imprimés du groupe tuner et ajuster TCO pour que la fréquence délivrée à LOCAL OUT à la broche (7) F.OUT corresponde à 118,7 MHz.
- (Note 6) Réduire le niveau de sortie du générateur de signal FM au fur et à mesure que les réglages progressent et la réduire finalement pour que le bruit vienne chevaucher les formes d'ondes de sortie (à un point tel que le limiteur ne réagisse plus).
- (Note 7) Raccorder un indicateur de zéro à courant continu entre R222 et R223 de la plaquette à circuits imprimés du tuner et ajuster le noyau T201-L1 pour obtenir une lecture de 0 V \pm 60mV.
- (Note 8) Quand le réglage de distortion est réalisé, il existera un léger écart de réglage du discriminateur, opération qui est réalisée en 5. Par conséquent, les réglages 5 et 6 doivent être faits à plusieurs reprises de façon à obtenir une indication de 0 V à l'indicateur de zéro à courant continu quand la distortion est minimale.

AUDIO ALIGNMENT • AUDIO-ABGLEICH • REGLAGE AUDIO

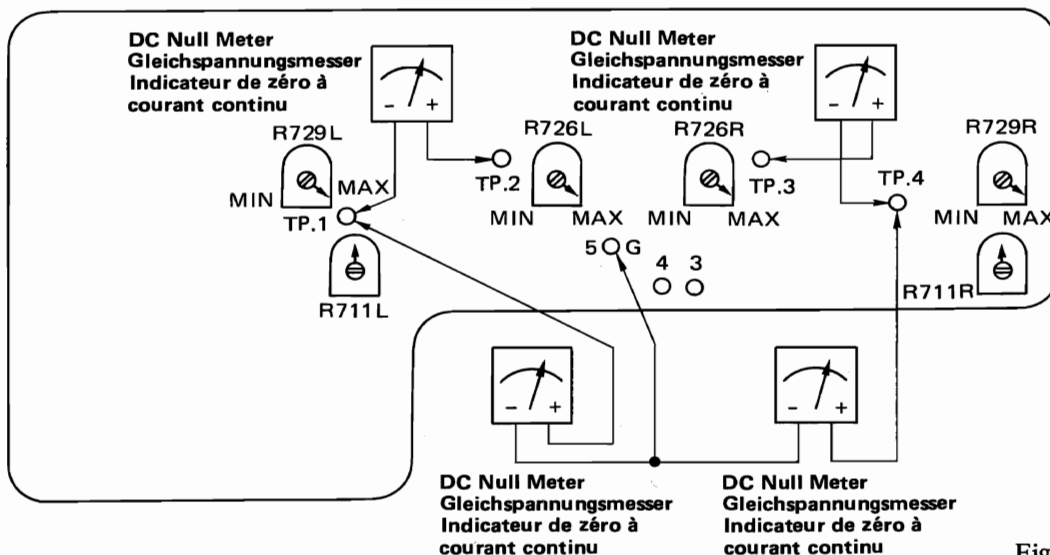

Fig. 6 Abb. 6

Condition: Function free
Volume: minimum
Speaker: off

Bedingungen: Funktionswähler: Beliebig
Lautstärke: Minimum
Lautsprecher: Abgeschaltet

Conditions: Fonction: au choix
Volume: minimum
Haut-parleur: OFF

Item Benennung Désignation	Measuring Instrument Meßinstrument Appareil de mesure	Point to be measured Meßpunkt Point de mesure	Adjust Abgleich Réglage	Value Adjusted Einstellwert Valeur ajustée
Output D C Gleichspannungsausgang Courant continu de sortie	D C Null Meter Gleichspannungsmesser Indicateur de zéro à courant continu	G – TP.1 G – TP.4	R711 L, R	0 V ± 20 mV
Idle current Blindstrom Courant déwatté	D C Null Meter Gleichspannungsmesser Indicateur de zéro à courant continu	TP.1 – TP.4 TP.4 – TP.3	1. R726 L, R 2. R729 L, R Caution Vorsicht Attention	6 mV ± 2 mV (27 mA ± 10 mA)

Caution

1. Perform audio adjustment at least 5 minutes after the power has been switched on.
2. First, turn R726, L, R counterclockwise set to 6 mV. Next, turn R729 L, R counterclockwise and stop at the position with the lowest value (if the value indicated is reduced), and stop it at the position where the value indicated starts increasing (if there is no position with minimum value).
Repeat the above operation until the indicated value is within 6 mV ± 2 mV.

Vorsicht

1. Den Audio-Abgleich frühestens 5 Minuten nach dem Einschalten des Netzschalters durchführen.
2. Zuerst R726 L/R gegen den Uhrzeigersinn drehen und auf 6 mV einstellen. Danach R729 L/R gegen den Uhrzeigersinn drehen, bis der niedrigste Wert (wenn der angezeigte Wert reduziert wird) erreicht ist bzw. bis die Anzeige anzusteigen beginnt (falls keine Position mit Minimalwert gefunden wird).
Den obigen Vorgang wiederholen, bis die Anzeige innerhalb von 6 mV ± 2 mV liegt.

Attention:

1. Effectuer les réglages audio au moins 5 minutes après la mise sous tension.
2. En premier lieu, tourner R726, L, R dans le sens contraire des aiguilles d'une montre pour obtenir 6 mV. Ensuite, tourner R729 L, R dans le sens contraire des aiguilles d'une montre et s'arrêter à la position qui permet d'obtenir la plus petite valeur (si la valeur indiquée est réduite) et s'arrêter à la position où la valeur indiquée commence à augmenter (s'il n'existe aucune position de valeur minimum).
Répéter l'opération ci-dessus jusqu'à ce que la valeur indiquée soit de 6 mV ± 2 mV.

AM TUNER ALIGNMENT • ABGLEICH DES AM-TUNERS • REGLAGE DU TUNER AM

Condition: Function: AM
Modulation: 400 Hz 30%

Bedingung: Funktion: AM
Modulation: 400 Hz 30%

Conditions: Fonction: AM
Modulation: 400 Hz 30%

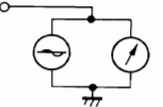
Sequence Reihenfolge Séquence	Connection Anschluß Connexion		Setting Setzen Montage		Adjust for Einstellen für Réglage pour	
	Input Eingang Entrée	Output Ausgang Sortie	Tuning Abstimmung Indicateur d'accord	Signal Signal Signal	Adjust Einstellen Réglage	Indication Indication Indication
1	IF Amp. ZF Verstärker Amplificateur de fréquence intermédiaire R229 D 0.1µ 100k	Out Ausgang Sortie In Tuner PWB Eingang Entrée C153 100K 0.1µ		450 kHz	T153	 Caution 1 Vorsicht 1 Attention 2
2	Loop antenna Rahmenantenne Antenne en carton	V.C.O. Tuner PWB	530 kHz or 522 kHz		T152	DC voltage: 1.8 V Caution 2 Vorsicht 2 Attention 2
3	Tracking Vorstufe Alignement		600 kHz or 603 kHz	600 kHz or 603 kHz	T151	V max. Caution 3 Vorsicht 3 Attention 3
			1400 kHz or 1404 kHz	1400 kHz or 1404 kHz	CT151	

Caution

1. Adjust black cores of T153 so that the waveform is as shown in Fig. 7. As T153 contains a 450 kHz ceramic filter, sometimes the 450 kHz point will not correspond to that of the waveform. In this case ignore the marker. After adjusting as above, increase the output level of the sweep generator and adjust T153 again so that the top of the waveform A (indicated in Fig. 8) will be flat and wide.
2. Carry out this adjustment for final adjustment of the coil only when you have moved the core by mistake.
3. Set the input level to 74 dB in coarse adjustment. Reduce the input level to minimum (50 dB) as adjustment proceeds.

Vorsicht

1. Die schwarzen Kerne von T153 so einstellen, daß die Kurvenform der in Abb. 7 dargestellten entspricht. Da T153 einen 450 kHz Keramikfilter enthält, entspricht manchmal der 450 kHz-Punkt nicht dem der Kurvenform; dabei einfach die Markierung ignorieren. Nach der zuvor beschriebenen Einstellung den Ausgangspegel des Oszillators erhöhen und T153 abermals einstellen, so daß die Spitze der Kurvenform A (s. Abb. 8) flach und breit wird.
2. Diese Einstellung zur abschließenden Angleichung der Spule nur vornehmen, wenn der Kern irrtümlich bewegt wurde.
3. Den Eingangspegel auf 74 dB grob einstellen. Auf minimal 50 dB nach Verlauf der Einstellung zurückstellen.

Attention

1. Régler les âmes noires de T153 de façon à obtenir une forme d'onde comme indiquée sur la fig. 7. Comme T153 contient un filtre en céramique de 450 kHz, le point de 450 kHz ne correspondra parfois pas à celui de la forme d'onde. Dans ce cas, ne pas s'occuper du marqueur. Après avoir réglé comme indiqué ci-dessus, augmenter le niveau d'entrée du générateur de balayage et régler T153 à nouveau de façon que le sommet de la forme d'onde A (voir Fig. 8) soit aplati et large.
2. N'effectuer le dernier réglage de la bobine par ce réglage que si vous avez bougé l'âme par erreur.
3. Faire un réglage approximatif du niveau d'entrée à 74 dB. Réduire le niveau d'entrée jusqu'à un minimum de 50 dB à mesure que l'on effectue le réglage.

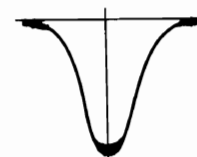

Fig. 7 Abb. 7

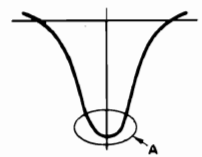

Fig. 8 Abb. 8

DESCRIPTION OF CONTROLLER IC502(μPD1703C-011)

1. Controller IC502 (μPD1703C-011) pin function table

Pin No.	Symbol	Name	Content (details)
1 2	E01, E02	Error Out	These are the charge pump outputs of the phase detector which composes the PLL.
3	CE	Chip Enable	This is the terminal to determine whether or not to set the controller to Enable. It is set to Enable at high level.
4	PSC	Prescaler Control	This is the output terminal of select signal which determines the prescaler division rate in the pulse swallow system.
5 6	X1, X2	X'tal OSC.	These are the connecting terminals of the 4.5 MHz crystal oscillator.
7	SD	Station Detector	This is the input terminal of sweep stop signal during Auto-tuning (Auto Up/Down).
8	MUTE	Muting Output	This is the muting output terminal during FM/AM band selection, Auto/Manual tuning and Press memory re-call. This is active high.
9 – 13	P1 – P5	Digit Outputs	These are the output terminals of digit signals for display and are active low.
14	V _{DD}		This is the power terminal of the controller.
15 – 21	Sa – Sg	Segment Outputs	These are display segment output/key return signal source terminal, and are active high.
22 – 25	K0 – K3	Key Return Signal Input	There are input terminals of the return signal output from the key matrix.
26	FM	FM Local Oscillator Input	This is the terminal to input the output signal which has been produced dividing the FM local oscillation output by 16 and 17, with prescaler μPB553AC.
27	GND	GND	This is the GND terminal of the controller.
28	AM	AM Local Input	This is the terminal to input the AM local oscillation output.

Controller IC502 pin diagram (Top View)

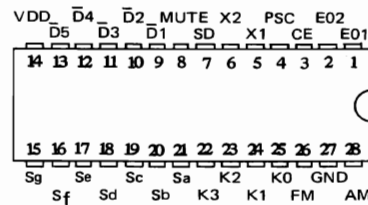

Fig. 9

2. Key matrix composition

Input terminal \ Output terminal	K3	K2	K1	K0	Type of switch
Sa		MEMORY	UP	DOWN	Momentary switch
Sb	P1	P2	P3	P4	
Sc	P5	P6			
Sd					
Se	AM/FM	AUTO/MANUAL		108/104	Alternate switch (108/104 excluded)
Sf	U.S.A. AM 10k/9k				Initial setting switch (108/104 included)
Sg			Band 1	Band 0	

3. Description of key matrix

3-1. Initial setting switch

Symbol	Description of function									
BAND 1 BAND 0	<p>This is the switch for setting reception band. Either U.S. or Europe bands can be selected.</p> <table border="1"> <thead> <tr> <th>BAND 1</th> <th>BAND 0</th> <th>BAND AREA</th> </tr> </thead> <tbody> <tr> <td>ON</td> <td>OFF</td> <td>U.S. Band for U.S.A. Canada</td> </tr> <tr> <td>OFF</td> <td>ON</td> <td>Europe Band except for U.S.A. Canada</td> </tr> </tbody> </table>	BAND 1	BAND 0	BAND AREA	ON	OFF	U.S. Band for U.S.A. Canada	OFF	ON	Europe Band except for U.S.A. Canada
BAND 1	BAND 0	BAND AREA								
ON	OFF	U.S. Band for U.S.A. Canada								
OFF	ON	Europe Band except for U.S.A. Canada								
U.S.A. AM 10K/9K	<p>This switch selects the AM channel space and the PLL reference frequency in the U.S. band (Not concerned with Europe band). ON 10KHz OFF 9KHz</p>									
108/104	<p>This switch sets the FM max. frequency in the Europe band. ON 87.50 – 108.00 MHz OFF 87.50 – 104.00 MHz</p>									

3-2 Alternate switch

Symbol	Description of function
AM/FM	<p>AM/FM band selector switch. ON AM band OFF FM band</p>
AUTO/MANUAL	<p>Auto/Manual tuning select switch. ON Auto tuning OFF ... Manual tuning</p>

3-3 Instantaneous switch

Symbol	Name	Description of function
UP	AUTO (FM only)	Auto up tuning When the UP key is depressed, Sweep-up continues at approx. 80 ms interval in the sawtooth wave mode. Sweep-up stops when a station is detected.
	MANUAL	Manual up tuning Everytime the UP key is depressed, the frequency increases by one steps of channel spacing frequency. With the UP key is kept depressed for more than 0.5 sec., Sweep-up continues at intervals of approx. 80 ms until the key is released.
DOWN	AUTO (FM only)	Auto down tuning Same as Auto up tuning except Sweep down.
	MANUAL	Manual down tuning Same as Manual up tuning except Sweep down.
P1 – P6	Preset memory	This is the preset memory WRITE or RECALL key. This memory is for both AM/FM independently with one button.
MEMORY	Memory write	<p>When this key is depressed, the memory write indicator lights and it is now possible to write data into the memory. The address is designated with the (P1) through (P6) keys and the operation is completed. Details on the operations are given below.</p> <p>(a) Unless any of the (P1) through (P6) keys is depressed within about 5 seconds, the memory write is automatically reset after about 5 seconds and the memory write indicator goes off.</p> <p>(b) If one of the (P1) through (P6) keys is depressed within about 5 seconds, the PLL data is stored in the corresponding address. At the same time, the memory write is reset, the memory write indicator goes off and the station indicator lights.</p>

4. Description of display

The diagram in Fig.10 shows the display connection. D1 – D5 and Sa – Sg in the diagram in Fig. 10 correspond to digit terminals (D1 – D5) and segment terminals (Sa – Sg) of IC502 (μ PD1703C-011).

* The signal which drives this digit and segment (Decimal Point) is not output from μ PD-1703C-011, so this digit is connected to D5 and the segment to FM (Sd) in this unit.

Note: The indication \square of the lowest digit signal D1 shows FM 50 KHz indication in European FM BAND.

In European FM BAND this digit is \square or 5, so it is output divided in 3 sections, 1) common section with \square and 5, 2) section requiring only \square and 3) the section requiring only 5.

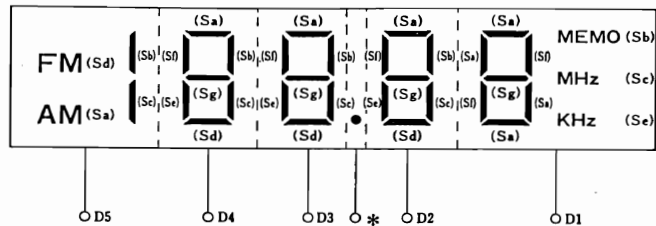

Fig. 10

BESCHREIBUNG DES REGELKREISES IC502(μ PD1703C-011)

1. Regler IC502 (μ PDI703C-011) Stiftebelegung

Stift-Nr.	Symbol	Benennung	Beschreibung
1 2	E01 E02	Fehler-Ausgang	Ausgänge des Detektors, der die PLL-Servoschleife bildet.
3	CE	Chip-Steuerimpuls	Dieser Stift bestimmt, ob der Regler in Funktion gesetzt wird oder nicht. Bei eingeschaltetem Regler liegt hier ein hohes Potential an.
4	PSC	Frequenzteiler-Regler	Der Ausgangsstift für das Wahlsignal der Frequenzteilung im Impulssystem.
5 6	X1 X2	Empfangsoszillator	Hier wird der 4, 5 MHz Kristalloszillator angeschlossen.
7	SD	Stations-Detektor	Eingangsstift für das Stoppsignal bei automatischem Sendersuchlauf (Auto Up/Down). Der Suchlauf wird gestoppt, wenn hier ein hochpegeliges Signal anliegt.
8	MUTE	Muting-Ausgang	Die Muting-Ausgangsklemme für UKW/MW-Empfangsbereichwahl, automatische/ manuelle Sendersuche und Speicher-Abruf. Aktiviert wird die Muting-Schaltung bei anliegendem hohem Pegel.
9 – 13	P1 – P5	Ziffern-Ausgänge	Die Ausgänge für die Ziffern der Anzeige; aktiviert bei Nullpegel.
14	V _{DD}		Der Stift für die Stromversorgung des Reglers.
15 – 21	Sa – Sg	Segment-Ausgänge	Ausgänge für die einzelnen Segmente der Ziffern-Anzeige; aktiviert bei hohem Pegel.
22 – 25	K0 – K3	Tasten-Rückmelde-signaleingang	Dies sind die Eingangsklemmen für das Rückmeldesignal der Tastenmatrix.
26	FM	UKW-Empfangsoszillator-Eingang	Hier wird das Signal eingegeben, das vom UKW-Empfangsoszillator kommt und durch die Ausgänge 16 und 17 geteilt wurde, wurde, mit Frequenzteiler μ PB553AC.
27	GND	Masse (GND)	Die Masseklemme des Reglers.
28	AM	MW-Empfangsoszillator-Eingang	An dieser Klemme wird der Ausgang des MW-Empfangsoszillators eingespeist

Stiftanordnung des Reglerkreises IC502 (Draufsicht)



Abb. 9

2. Tastenmatrix-Komposition

Anschluß- klemme	K3	K2	K1	K0	Schaltertyp
Sa		MEMORY	UP	DOWN	Sofortschalter
Sb	P1	P2	P3	P4	
Sc	P5	P6			
Sd					
Se	AM/FM	AUTO/MANUAL		108/104	Wahlschalter (ausschließlich 108/104)
Sf	U.S.A. AM 10k/9k				Einstellschalter (einschließlich 108/104)
Sg			Band 1	Band 0	

3. Beschreibung der Tastenmatrix

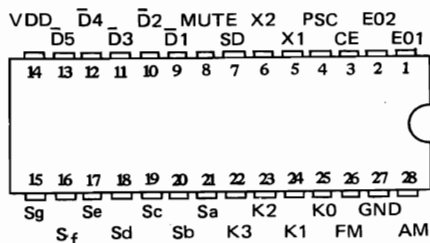
3-1. Einstellschalter

Symbol	Funktionsbeschreibung									
BAND 1 BAND 0	Mit diesem Schalter wird der Empfangsbereich eingestellt. Dabei kann zwischen den in den USA bzw. in Europa üblichen Empfangsbereichen gewählt werden. <table border="1" style="margin-left: 20px;"> <thead> <tr> <th>BAND 1</th> <th>BAND 0</th> <th>Bestimmungsland</th> </tr> </thead> <tbody> <tr> <td>ON</td> <td>OFF</td> <td>USA-Empfangsbereich Für USA, Kanada</td> </tr> <tr> <td>OFF</td> <td>ON</td> <td>Europa-Empfangsbereich Alle Bestimmungsländer, ausgenommen USA und Kanada.</td> </tr> </tbody> </table>	BAND 1	BAND 0	Bestimmungsland	ON	OFF	USA-Empfangsbereich Für USA, Kanada	OFF	ON	Europa-Empfangsbereich Alle Bestimmungsländer, ausgenommen USA und Kanada.
BAND 1	BAND 0	Bestimmungsland								
ON	OFF	USA-Empfangsbereich Für USA, Kanada								
OFF	ON	Europa-Empfangsbereich Alle Bestimmungsländer, ausgenommen USA und Kanada.								
U.S.A. AM 10K/9K	Dieser Schalter dient zur Auswahl des MW-Empfangsbereiches und der PLL-Bezugsfrequenz für den USA-Empfangsbereich (keine Funktion bei Europa-Empfangsbereich). ON 10 kHz OFF 9 kHz									
108/104	Mit diesem Schalter wird die höchste Frequenz des in Europa üblichen UKW-Empfangsbereiches eingestellt. ON 87,50 – 108,00 MHz OFF 87,50 – 104,00 MHz									

3-2. Wahlschalter

Symbol	Funktionsbeschreibung
AM/FM	MW/UKW-Empfangsbereich-Wahlschalter ON MW-Empfangsbereich OFF UKW-Empfangsbereich
AUTO/MANUAL	Wahlschalter für automatischen/manuellen Sendersuchlauf ON Automatischer Sendersuchlauf OFF ... Manuellen Sendersuchlauf

3-3. Sofortschalter



Symbol		Bezeichnung	Funktionsbeschreibung
UP	AUTO (nur UKW)	Automatischer Sendersuchlauf nach oben	Wenn die UP-Taste gedrückt wird, dann erfolgt der Sendersuchlauf nach oben in etwa 80 msek. Intervallen mit Hilfe der Sägezahnwelle. Der Suchlauf hält an, sobald ein Sender empfangen wird.
	MANUAL	Manueller Sendersuchlauf nach oben	Mit jedem Druck der UP-Taste nimmt die Empfangsfrequenz um einen Raster-schritt zu. Wird die UP-Taste für länger als 0,5 sek. gedrückt gehalten, dann wird der Empfangsbereich in Intervallen von etwa 80 msek. durchlaufen, so lange die Taste gedrückt gehalten wird.
DOWN	AUTO (nur UKW)	Automatischer Sendersuchlauf nach unten	Gleich wie bei automatischem Suchlauf nach oben, nur daß nun die Frequenz verringert wird.
	MANUAL	Manueller Sendersuchlauf nach unten	Gleich wie manueller Sendersuchlauf nach oben, nur daß nun die Frequenz verringert wird.
P1 – P6		Festsender-Speicher	Dies sind die Festsendertasten mit den Funktionen WRITE (Vorprogrammieren) und RECALL (Abrufen). Der Speicher arbeitet sowohl für MW, als auch für UKW mit jeweils den gleichen Tasten.
MEMORY		Speicher-Eingabe	Wenn diese Taste gedrückt wird, leuchtet die Speicher-Eingabelampe auf und die gewünschten Daten können in den Speicher eingegeben werden. Die Adresse wird mit Hilfe der Tasten P1 bis P6 eingegeben, worauf da Programmieren beendet ist. Nachfolgend sind weitere Einzelheiten über diese Vorgänge aufgeführt. (a) Eine der Tasten P1 bis P6 muß innerhalb von 5 Sekunden nach dem Aufleuchten der Speicher-Eingabetaste gedrückt werden, das anderenfalls der Speicher automatisch zurückgestellt wird und die Speicher-Eingabetaste nach ca. 5 Sekunden erlischt. (b) Wird eine der Tasten P1 bis P6 innerhalb von 5 Sekunden nach dem Aufleuchten der Speicher-Eingabelampe betätigt, dann werden die PLL-Daten an der entsprechenden Adresse gespeichert. Gleichzeitig wird die Speicher-Eingabefunktion gelöscht, so daß die Speicher-Eingabelampe erlischt. Es leuchtet nun die entsprechende Stationsanzeige auf.

4. Beschreibung der Anzeige

Im nachfolgenden Diagramm Abb.10 sind die Anschlüsse für die Anzeige dargestellt. D1–D5 und Sa–Sg entsprechen den Ziffernklemmen (D1–D5) bzw. den segmentenklemmen (Sa – Sg) von IC502 (μ PD1703C-011).

* Das Signal für die Steuerung dieser Ziffer und dieses Segmentes (Dezimalpunkt) wird nicht von μ PD-1703C-011 ausgegeben; daher wurde in dieser Einheit die Ziffer an D5 und das Segment an FM (Sd) angeschlossen.

Hinweis: Die Anzeige  des niedrigsten Stellensignals D1 ergibt eine 50 kHz Anzeige (UKW) in Europa.

In Europa ist diese Stelle  oder 5, d.h. Ausgang wird in drei Abschnitte unterteilt, 1) Gemeinsamer Abschnitt mit  und 5, 2) Abschnitt erforderlich nur für , und 3) Abschnitt erforderlich nur für 5.



Abb. 10

DESCRIPTION DU CONTROLEUR IC502(μPD1703C-011)

1. Table des fonctions de broches du contrôleur IC502 (μPD1703C-011)

BrocheNo	Symbole	Désignation	Description
1 2	E01 E02	Sortie d'erreur	Ce sont les broches de sortie de charge du détecteur qui composent le circuit phase.
3	CE	Validation ultra-plate	Borne qui détermine la validation ou la non validation du contrôleur. Il est mis en validation à haut niveau.
4	PSC	Commande à prédétermination	Borne de sortie du signal de sélection de valeur de division de prédétermination de l'impulsion du système de balayage.
5 6	X1 X2	Oscillateur à cristal	Points de raccordement de l'oscillateur à cristal de 4,5 MHz.
7	SD	Détecteur de station	Borne d'entrée de signal d'arrêt de balayage au cours du mode d'accord automatique (recherches automatiques progressivé et régressive).
8	MUTE	Sortie de réglage silencieux	Borne de sortie de réglage silencieux au cours de la sélection de bande FM/AM, de l'accord manuel/automatique et du rappel de mémoire.
9 – 13	P1 – P5	Sorties numériques	Bornes de sortie de signal numérique d'affichage actives à basse tension.
14	V _{DD}		Borne d'alimentation du contrôleur.
15 – 21	Sa – Sg	Sorties de segment	Sortie de signal de segment d'affichage/bornes de source de signal de retour de touches actives à haute tension.
22 – 25	K0 – K3	Entrée de signal de retour de touche	Bornes d'entrée de sortie de signal de retour provenant de la matrice de touche.
26	FM	Entrée de l'oscillateur local FM	Cette borne injecte la sortie qui a été générée divisant la sortie d'oscillation locale FM par 16 et 17.
27 28	GND AM	Masse Entrée de l'oscillateur local	Borne de masse du contrôleur. Borne qui permet d'injecter la sortie d'oscillation locale AM.

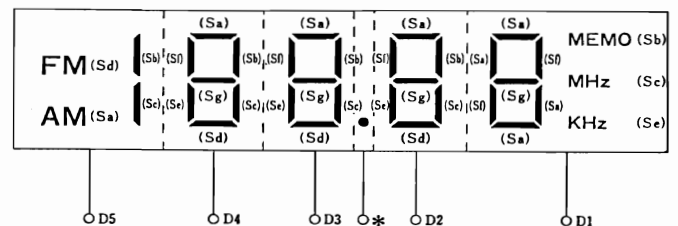
Schéma de broches
du contrôleur IC502
(Vu de dessus)

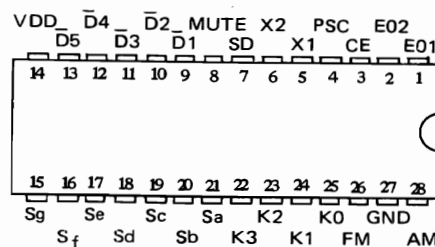

Figure 9

2. Composition matricielle de touche

Borne de sortie \ Borne d'entrée	K3	K2	K1	K0	Type d'interrupteur
Sa		MEMORY	UP	DOWN	Interrupteur instanté
Sb	P1	P2	P3	* P4	
Sc	P5	P6			
Sd					
Se	AM/FM	AUTO/MANUAL		108/104	Interrupteur alterné (saut 108/104)
Sf	U.S.A. AM 10k/9k				Interrupteur de réglage initial (108/104 compris)
Sg			Band 1	Band 0	

3. Description de matrice de touche

3-1. Interrupteur de réglage initial

Symbole	Description de fonction									
BAND 1 BAND 0	<p>Cet interrupteur est prévu pour effectuer le réglage de bande de réception. Il est donc possible de choisir indifféremment les bandes américaines ou européennes.</p> <table border="1" style="margin-left: 40px;"> <thead> <tr> <th>Bande 1</th> <th>Band 0</th> <th>Zone de bande</th> </tr> </thead> <tbody> <tr> <td>Marche</td> <td>Arrêt</td> <td>Band américaine Pour bande américaine, Canadienne</td> </tr> <tr> <td>Arrêt</td> <td>Marche</td> <td>Bande européenne Partout saut aux Etats-Unis et au Canada</td> </tr> </tbody> </table>	Bande 1	Band 0	Zone de bande	Marche	Arrêt	Band américaine Pour bande américaine, Canadienne	Arrêt	Marche	Bande européenne Partout saut aux Etats-Unis et au Canada
Bande 1	Band 0	Zone de bande								
Marche	Arrêt	Band américaine Pour bande américaine, Canadienne								
Arrêt	Marche	Bande européenne Partout saut aux Etats-Unis et au Canada								
U.S.A. AM 10K/9K	<p>Cet interrupteur permet de sélectionner la zone de canal AM et la fréquence de référence de circuit en phase dans la bande américaine (ne concerne pas la bande européenne). ON 10 kHz, OFF 9 kHz</p>									
108/104	<p>Cet interrupteur règle la fréquence FM maximum dans la bande européenne. ON 87,50 à 108 MHz; OFF 87,50 à 104 MHz.</p>									

3-2. Interrupteur intermédiaire

Symbole	Description de fonction
AM/FM	<p>Sélecteur de bande AM/FM ON Bande AM OFF Bande FM</p>
AUTO/MANUAL	<p>Sélecteur d'accord manuel/automatique. ON Accord automatique OFF Accord manuel</p>

3-3. Interrupteur instantané



Symbole		Nom	Description de fonction
UP	AUTO	Accord automatique progressif	Quand la touche UP est pressée, un balayage progressif se poursuit par intervalle d'environ 80 ms en mode d'onde en dent de scie. Le balayage progressif est interrompu quand une station est détectée.
	MANUAL	Accord manuel progressif	A chaque fois que la touche UP est pressée, la fréquence augmente d'une valeur d'un canal. Quand la touche UP est maintenue pressée pendant plus de 0,5 sec. le balayage progressif se poursuit par intervalle d'environ 80 ms, et ce tant que la touche UP est pressée.
DOWN	AUTO	Accord automatique régressif	Mode identique au balayage automatique progressif à l'exception qu'il se déroule en régression.
	MANUAL	Accord manuel régressif	Identique au mode d'accord manuel progressif à l'exception qu'il se déroule en régression.
P1 - P6		Mémoire préréglée	Touche d'introduction en mémoire (WRITE) ou de rappel de données (RECALL) de la mémoire préréglée. Cette mémoire est indépendamment destinée aux bandes AM/FM utilisant un seul bouton.
MEMORY		Introduction en mémoire	<p>Quand cette touche est pressée, le témoin d'introduction en mémoire s'allume pour indiquer qu'il est dès à présent possible d'opérer une introduction de données en mémoire. L'adresse est opérée avec les touches P1 à P6 et l'opération se termine. Tous les détails concernant cette opération sont fournies ci-après.</p> <p>(a) A moins qu'une ou l'autre touche de P1 à P6 soit pressée en moins d'environ 5 secondes, les données en mémoire sont automatiquement ramenées à l'état initial environ 5 secondes après, tandis que le voyant d'introduction en mémoire s'éteint.</p> <p>(b) Si une des touches P1 à P6 est pressée en moins de 5 secondes environ, les données PLL sont stockées dans l'adresse correspondante et dans un même temps, les données en mémoire sont ramenées à zéro, le voyant d'introduction en mémoire s'éteint et le voyant de station s'allume.</p>

4. Description de l'affichage

Le diagramme sur la fig.10 représente le câblage de l'affichage. D1 à D5 et Sa à Sg du schéma sur la fig.10 correspondent aux bornes numériques (D1 à D5) et aux bornes de segment (Sa à Sg) du circuit IC502 (μ PD1703-011).

* Le signal de commande de chiffre et de segment (virgule décimale) n'est pas délivré par μ PD-1703C-011 de sorte que ce chiffre est relié à D5 et le segment à FM (Sd) dans ce dispositif.

Remarque: L'indication  du plus petit signal numérique D1 correspond à l'indication FM 50 KHz en Europe.

En Europe, ce chiffre est  ou 5 et il est délivré et divisé en trois parties: 1) section commune avec  et 5, 2) section impliquant uniquement  et 3) section impliquant uniquement 5.

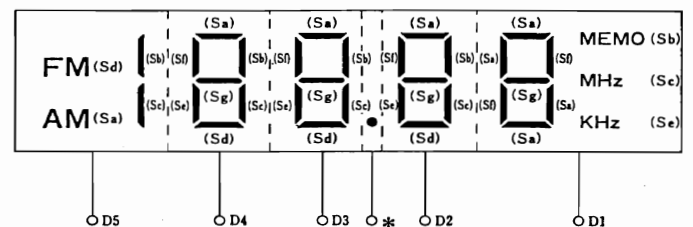
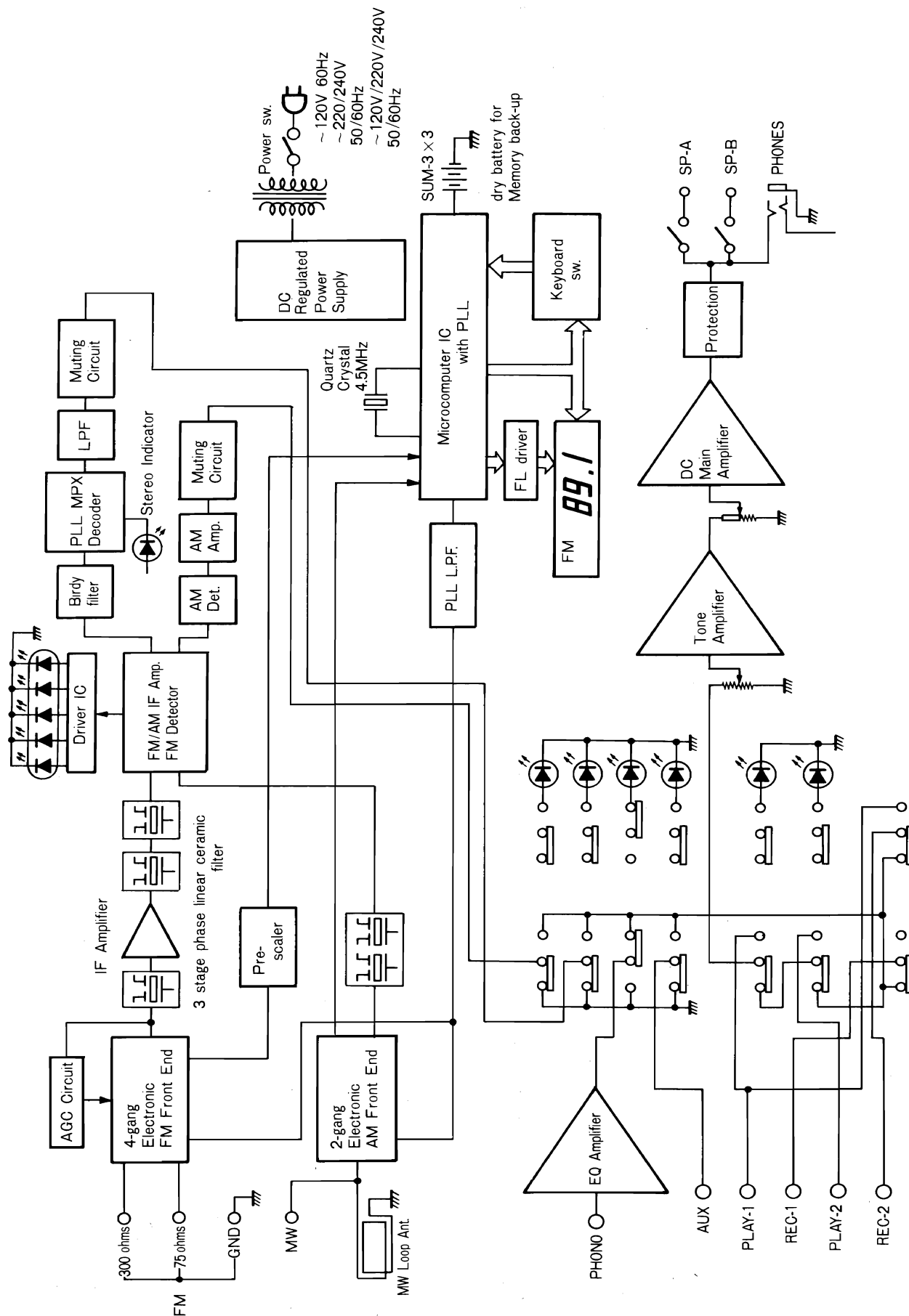

Figure 10

BLOCK DIAGRAM·BLOCK SCHEMA·SCHEMA



PRINTED WIRING BOARD · PRINTPLATTEN · PLAN DE BASE

[: +B, : -B, : Earth, : Other]

- *: Axial lead cylindrical ceramic capacitor
- *: Zylindrischer Keramikcondensator mit axialer zuleitung
- *: Condensateur céramique cylindrique à conducteur axial

The circuit symbol (—) means a fuse resistor. When replacing it with new one, refer to the CAUTION on page 23.
 Das Schaltsymbol (—) steht für Schmelzwiderstand. Beim Austausch bitte Seite 23 ZUR BEACHTUNG nachlesen.
 Le symbole de circuit (—) signifie qu'il s'agit d'une résistance à fusible. Consulter les instructions "ATTENTION" de la page 23 pour effectuer son remplacement.

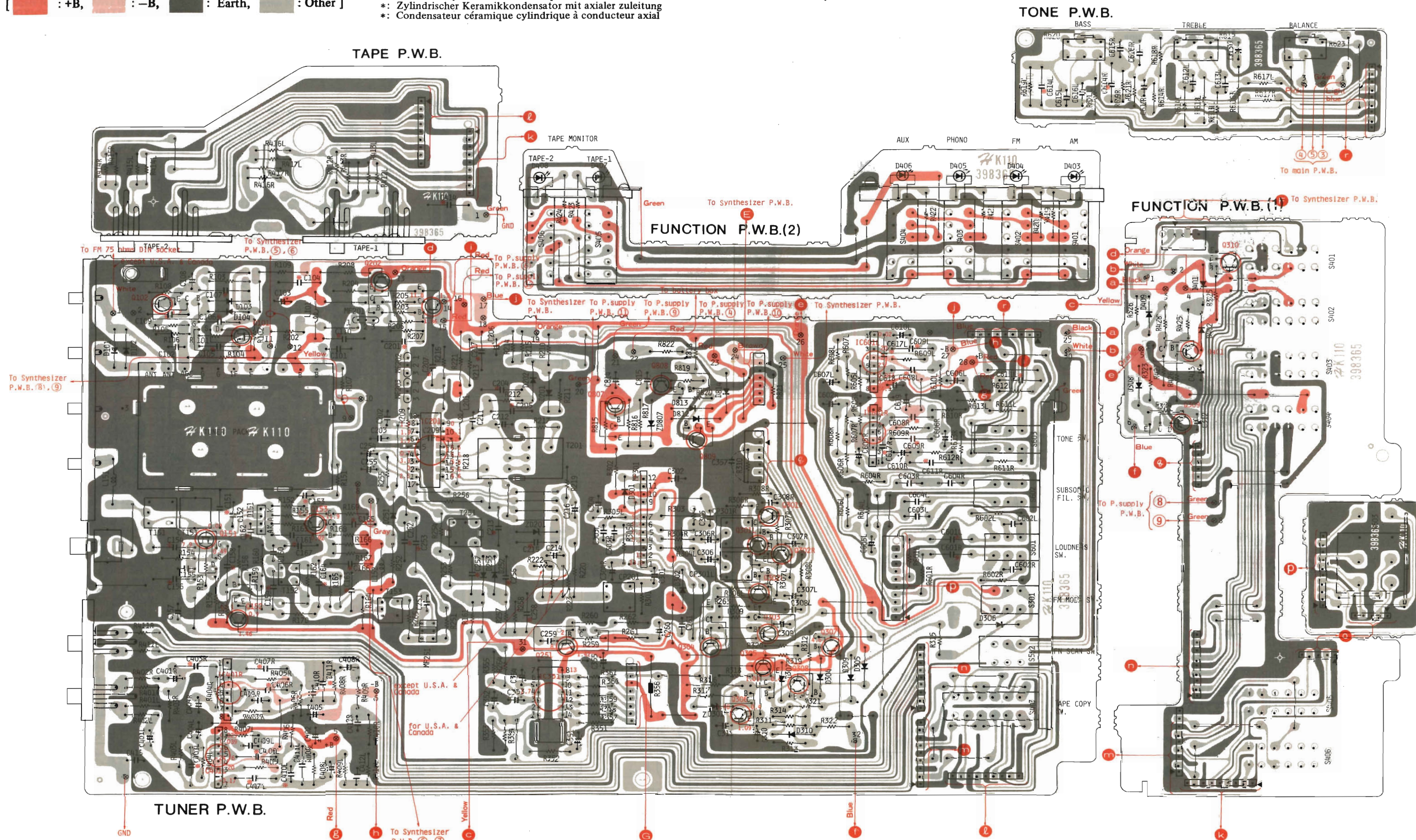

PRINTED WIRING BOARD·PRINTPLATTEN·PLAN DE BASE

[■ : +B, ■ : -B, ■ : Ground, ■ : Other]

- *: Axial lead cylindrical ceramic capacitor,
- *: Zylindrischer Keramikcondensator mit axialer zuleitung
- *: Condensateur céramique cylindrique à conducteur axial

The circuit symbol (■) means a fuse resistor. When replacing it with new one, refer to the CAUTION on page 23.
 Das Schaltsymbol (■) steht für Schmelzwiderstand. Beim Austausch bitte Seite 23 ZUR BEACHTUNG nachlesen.
 Le symbole de circuit (■) signifie qu'il s'agit d'une résistance à fusible. Consulter les instructions "ATTENTION" de la page 23 pour effectuer son remplacement.

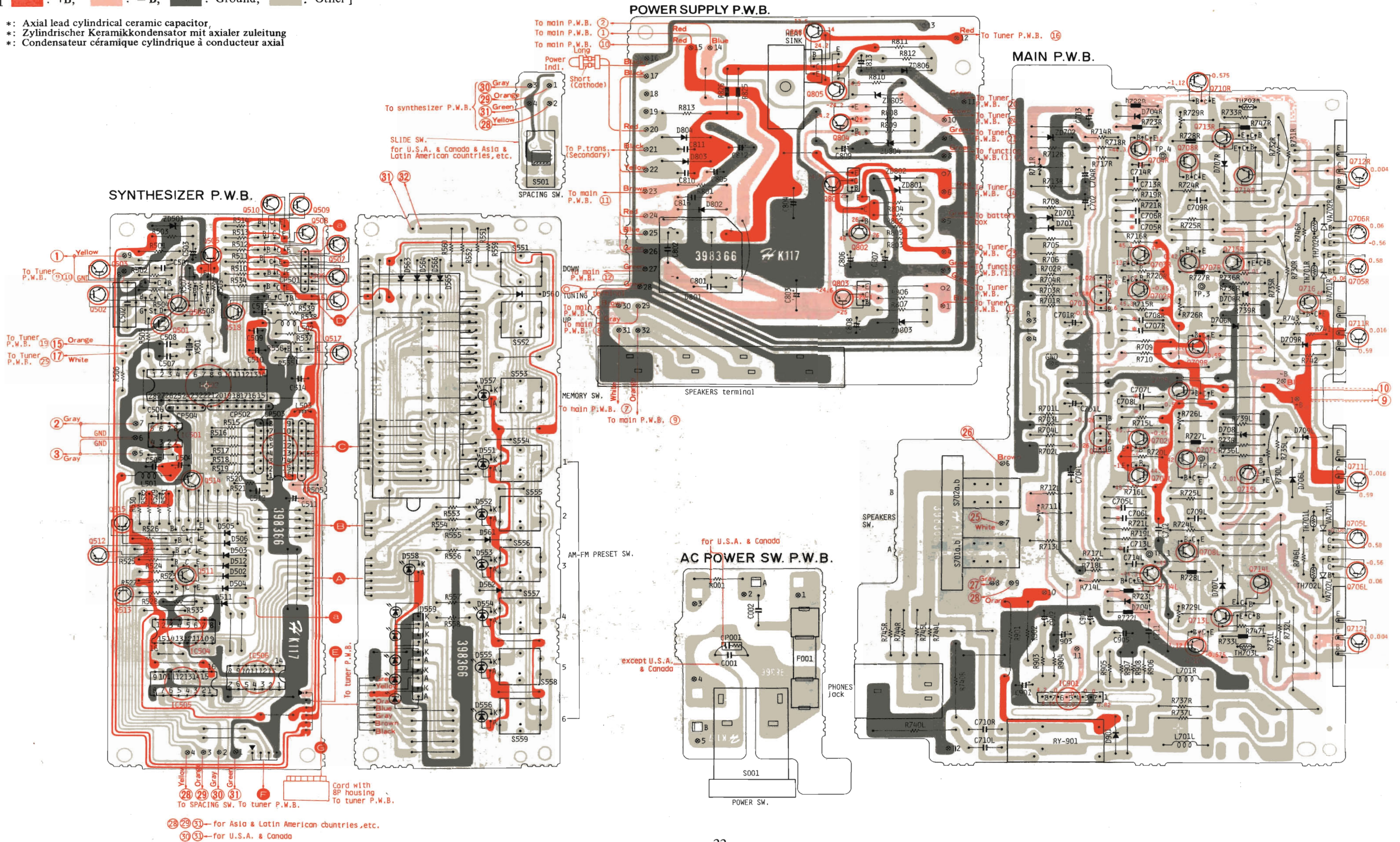

CIRCUIT DIAGRAM · SCHALTPLAN · PLAN DE CIRCUIT

PRODUCT SAFETY NOTE: Components marked with a Δ have special characteristics important to safety.
SICHERHEITSHINWEIS: Die mit Δ gekennzeichneten Komponenten haben wichtige Sicherheitsaufgaben.
NOTICE DE SECURITE DE FABRICATION: Les composants qui sont accompagnés du symbole Δ possèdent des caractéristiques spéciales.

- *: Axial lead cylindrical ceramic capacitor
- *: Zylindrischer Keramikcondensator mit axialer zuleitung
- *: Condensateur céramique cylindrique à conducteur axial

CAUTION: Fuse resistors are used to improve safety (to protect the circuit). When replacing them with new ones, be sure to use the designated type. Always use the designated fuse without fail.
ZUR BEACHTUNG: Schmelzwiderstände sind zur Erhöhung der Sicherheit vor gesehen (zum Schutz der Schaltung). Bei Austausch bitte nur die vorgeschriebene Type benutzen. Vergewissern Sie sich, daß die richtige Type gewählt ist.
ATTENTION: Les résistance à fusible sont faites pour améliorer la sécurité de l'appareil (protection de circuit). Pour les remplacer, utiliser le même type. Utiliser toujours le modèle de fusible spécifié pour effectuer le remplacement.

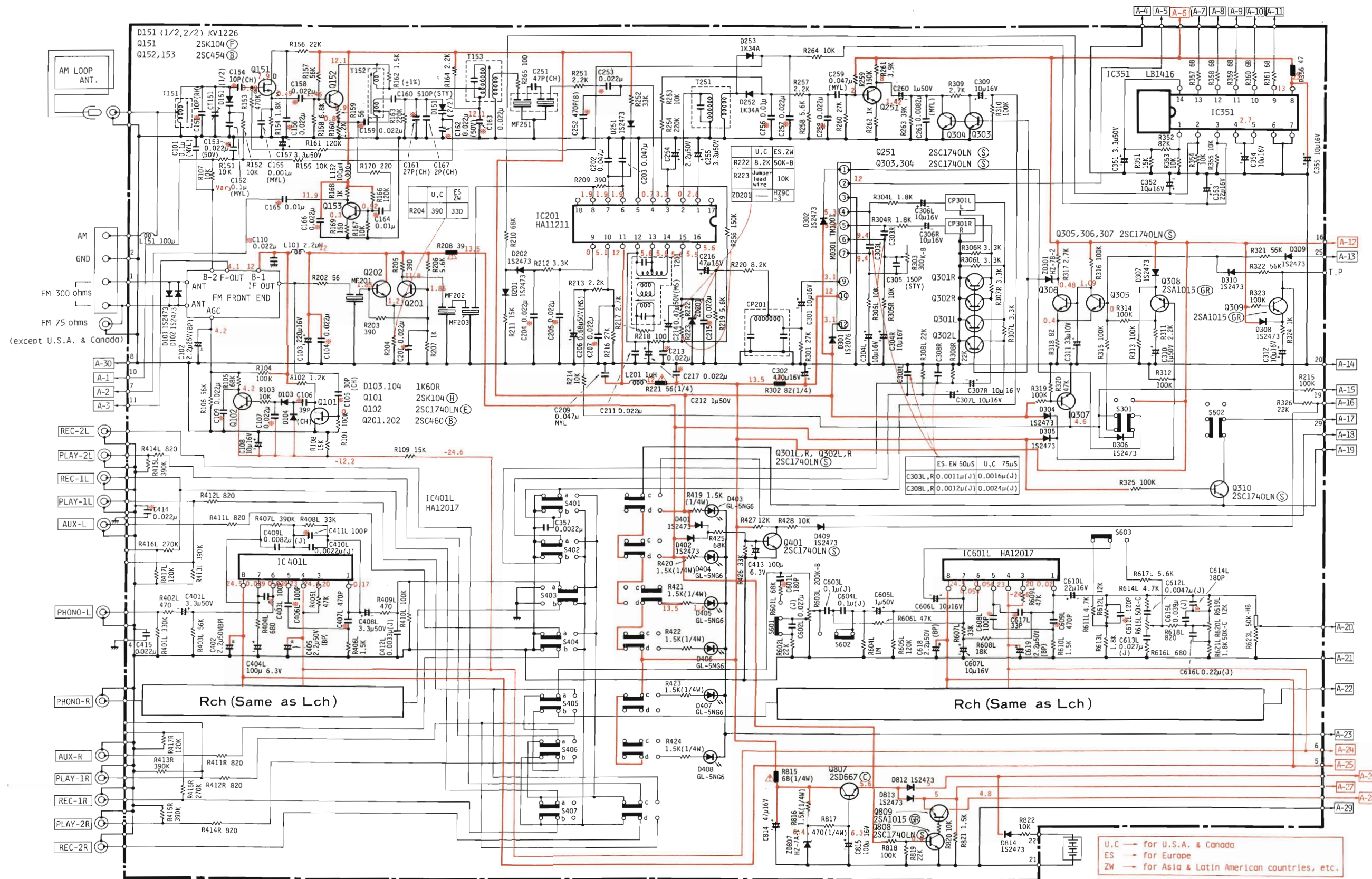

U.C → for U.S.A. & Canada
 ES → for Europe
 ZW → for Asia & Latin American countries, etc.

HA11211	1K60R 1K34A	2SK104
HA12002	GL-5NG6	2SC454 2SC460 2SC1740LN 2SC1775 2SC1775A 2SC1213 2SA1015 2SA872 2SA673
HA12017	TLR-205	2SD756 2SD667A 2SD667 2SB647A 2SB647 2SB716
LB1416	SLR-30GG SLR-30AR	2SC2259
LB1274	LED ARRAY (D59)	2SC2525 2SA1075
μ PB553AC	1SS81	MV-5
μ PD1703C-011	GL-5NG6	2SD330AL 2SB514AL
TC5066BP TC4035BP TC4028BP μ PD4035C μ PD4028C	1S2076	RD27EB3
PHONO-L PHONO-R	1S2076A	ERB-12-01R
AUX-R PLAY-1R REC-1R PLAY-2R REC-2R	KV-1226	5V8B20
REC-2L PLAY-2L REC-1L PLAY-1L AUX-L	1S2473	

The circuit diagram is subject to change for improvement without notice.
 Änderungen des Schaltplans im Sinne ständiger Verbesserung vorbehalten.
 Le schéma de montage est sujet à modification sans préavis, pour des raisons d'amélioration.

CIRCUIT DIAGRAM · SCHALTPLAN · PLAN DE CIRCUIT

PRODUCT SAFETY NOTE: Components marked with a Δ have special characteristics important to safety.
 SICHERHEITSHINWEIS: Die mit Δ gekennzeichneten Komponenten haben wichtige Sicherheitsaufgaben.
 NOTICE DE SECURITE DE FABRICATION: Les composants qui sont accompagnés du symbole Δ possèdent des caractéristiques spéciales.

- *: Axial lead cylindrical ceramic capacitor
- *: Zylindrischer Keramikcondensator mit axialer zuleitung
- *: Condensateur céramique cylindrique à conducteur axial

CAUTION: Fuse resistors are used to improve safety (to protect the circuit). When replacing them with new ones, be sure to use the designated type. Always use the designated fuse without fail.
 ZUR BEACHTUNG: Schmelzwiderstände sind zur Erhöhung der Sicherheit vorgesehen (zum Schutz der Schaltung). Bei Austausch bitte nur die vorgeschriebene Type benutzen. Vergewissern Sie sich, daß die richtige Type gewählt ist.
 ATTENTION: Les résistances à fusible sont faites pour améliorer la sécurité de l'appareil (protection de circuit). Pour les remplacer, utiliser le même type. Utiliser toujours le modèle de fusible spécifié pour effectuer le remplacement.

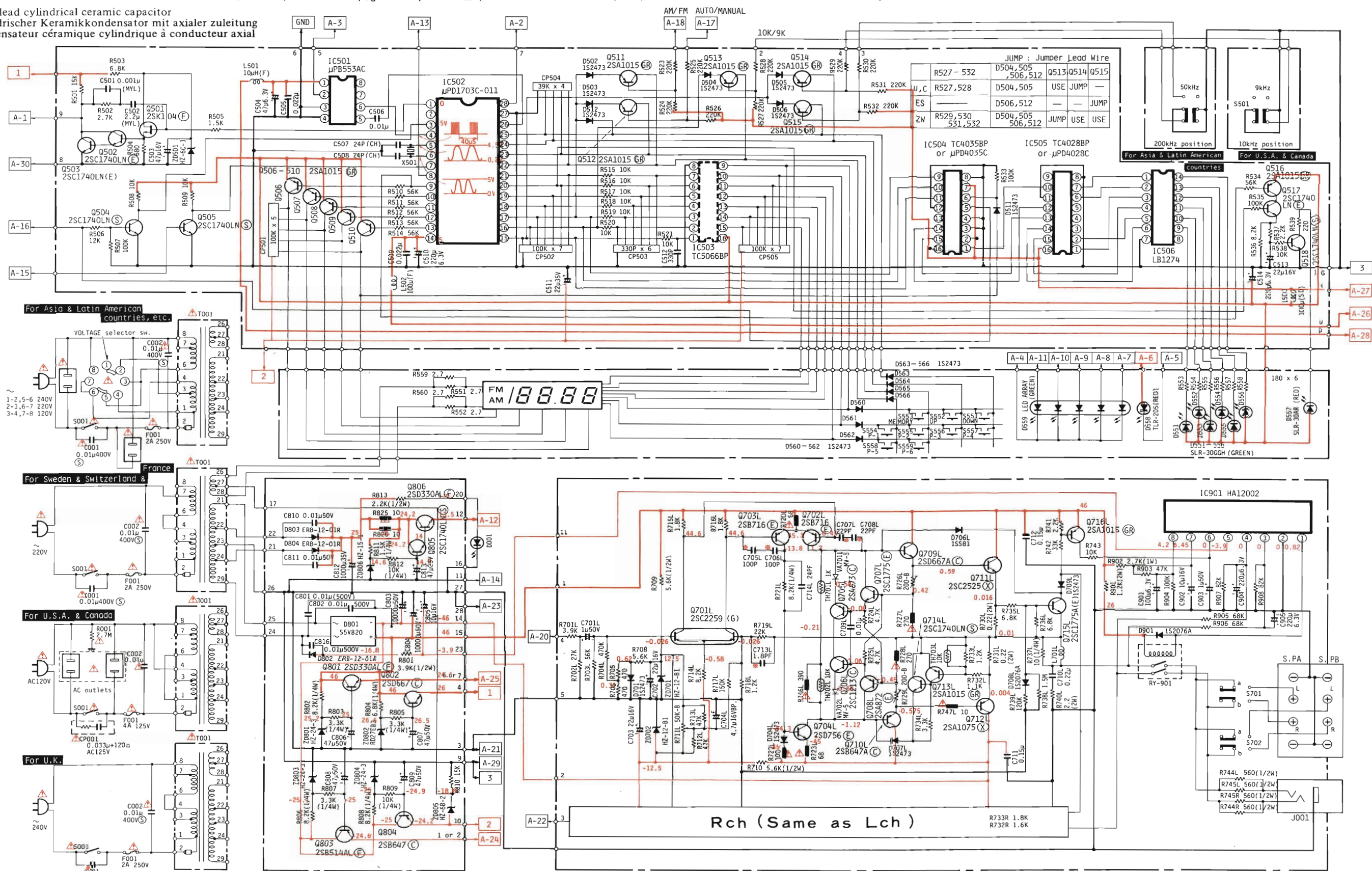

The circuit diagram is subject to change for improvement without notice.
 Änderungen des Schaltplans im Sinne ständiger Verbesserung vorbehalten.
 Le schéma de montage est sujet à modification sans préavis, pour des raisons d'amélioration.

U.C → for U.S.A. & Canada
 ES → for Europe
 ZW → for Asia & Latin American countries, etc.

CIRCUIT DIAGRAM · SCHALTPLAN · PLAN DE CIRCUIT

Tuner pack

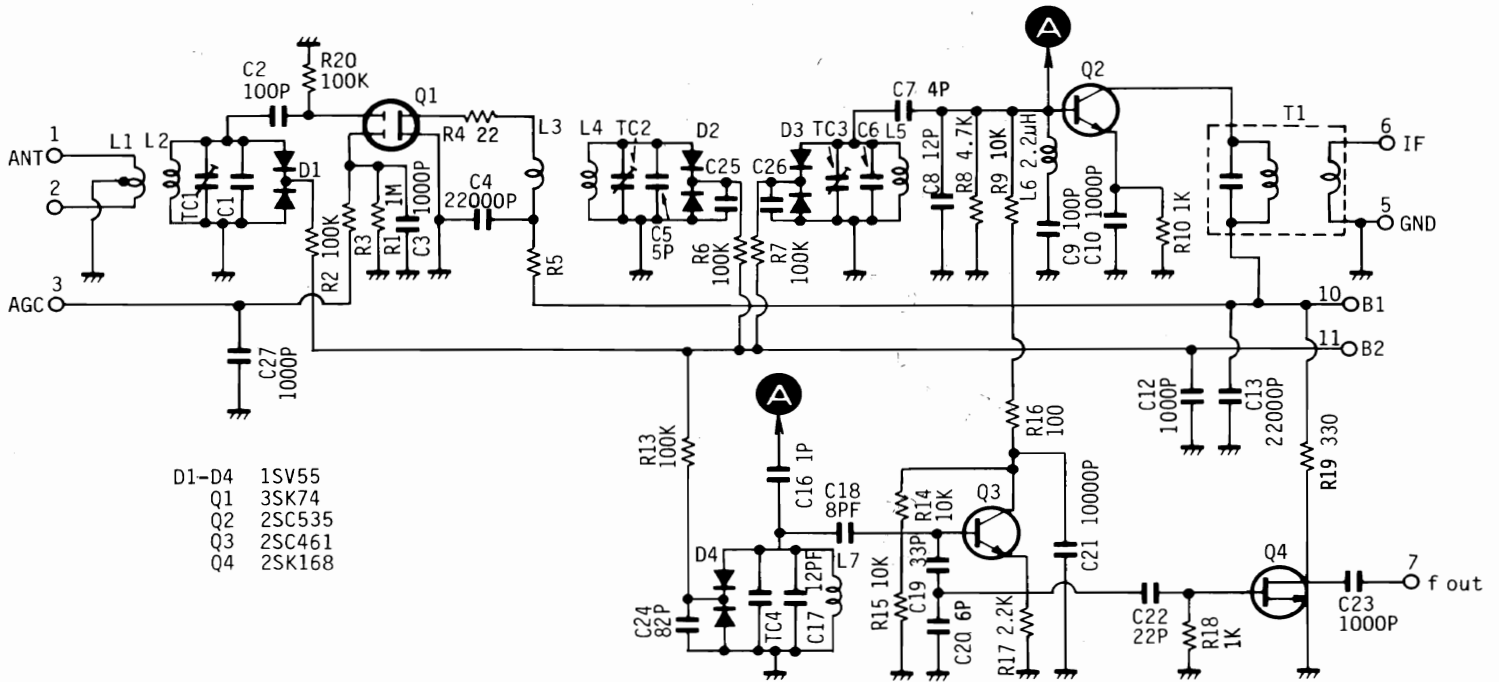

Fig. 11 Abb. 11

The circuit diagram is subject to change for improvement without notice.
 Änderungen des Schaltplans im Sinne ständiger Verbesserung vorbehalten.
 Le schéma de montage est sujet à modification sans préavis, pour des raisons d'amélioration.

DESCRIPTION OF NEW CIRCUIT

1. Preset channel address (station) indication

When the preset key is depressed, the indication output showing the address of the depressed key is output from segment terminals Se – Sg of μ PD1703C-113 at the timing of D5 of the highest digit signal in the BCD (Binary Coded Decimal) code.

The timing chart at that time is shown in Fig. 12 correspondence of the BCD code and preset channel address is shown in Table 1.

In this unit, this output is latched by IC504 (μ PD4035C or TC4035BP), the BCD code is decoded by IC505 (μ PD4028C or TC4028BP) to decimal, the LED which shows the preset channel address is lit by IC506 (LB1274) to display the preset channel address Fig. 13 shows the preset channel address display circuit.

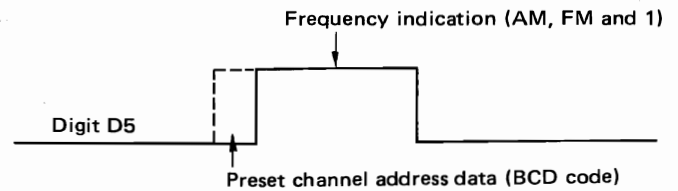

Fig. 12 Timing chart

Sg	Sf	Se	Preset channel
0	0	1	P1
0	1	0	P2
0	1	1	P3
1	0	0	P4
1	0	1	P5
1	1	0	P6

Table 1 Preset channel BCD code output

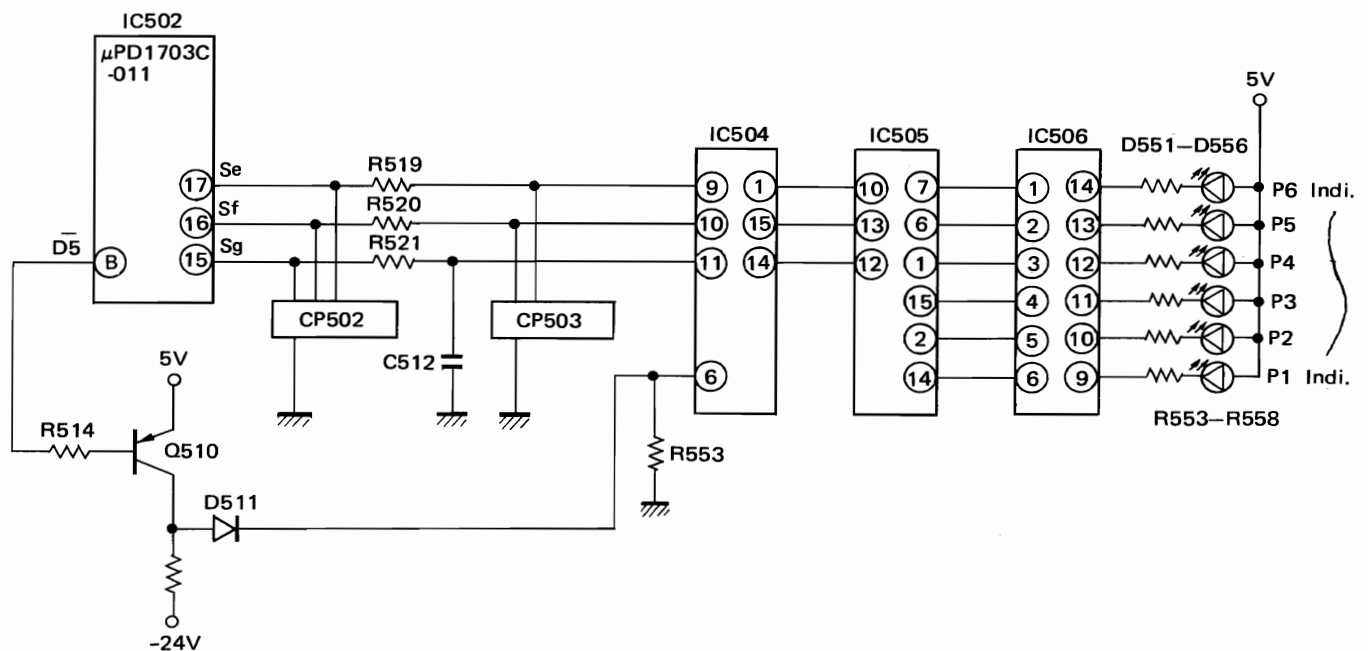

Fig. 13. Preset channel address circuit

Abb. 13. Schaltkreis für vorprogrammierte Festsenderadresse

Fig. 13. Circuit d'adresse de canal préaccordé

BESCHREIBUNG DES NEUEN SCHALTKREISES

1. Festsendertasten-Anzeige

Wenn eine der Festsendertasten gedrückt wird, dann wird das Anzeigesignal für die gedrückte Festsendertaste an den Segmentenklemmen Se – Sg von μ PD1703C-113 gemäß der Zeit-Steuerung von D5 des höchsten Stellen-signals als binärverschlüsselte Dezimale ausgegeben.

Das Zeitablaufdiagramm für diesen Vorgang ist in Abb. 12 dargestellt; der entsprechende binärverschlüsselte Dezimalkode und die Festsenderadresse sind in Tabelle 1 aufgeführt.

In dieser Einheit wird dieser Ausgang durch IC504 (μ PD4035C oder TC4035BP) verriegelt, der binärverschlüsselte Dezimalkode wird durch IC505 (μ PD4035C oder TC4035BP) entkodiert in eine Dezimale, und die die Festsenderadresse anzeigende Leuchtdiode (LED) wird über IC506 (LB1274) eingeschaltet, um die Festsenderadresse anzuzeigen. In Abb.13 ist der Anzeige-schaltkreis für die Adresse der betätigten Festsendertaste dargestellt.



Abb.12 Zeitablaufdiagramm

Sg	Sf	Se	Vorprogrammierter Festsender
0	0	1	P1
0	1	0	P2
0	1	1	P3
1	0	0	P4
1	0	1	P5
1	1	0	P6

Tabelle 1 Binärverschlüsselter Dezimalkodeausgang für Festsender

DESCRIPTION DU NOUVEAU CIRCUIT

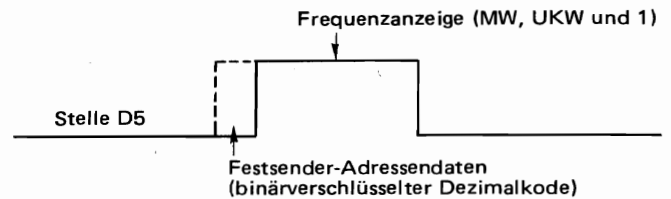
1. Indication d'adresse de canal préaccordé (station)

Quand la touche de préaccord est enfoncée, la sortie d'indication représentant l'adresse de la touche enfoncée est délivrée par les bornes de segment Se à Sg du circuit μ PD-1703C-011 en synchronisation à D5 du signal numérique le plus élevé en code BCD (décimal codé binaire).

Le diagramme de synchronisation correspond à ce moment là à ce que représente la figure 12 correspondance du code BCD et de l'adresse de canal préaccordé représentée dans le tableau.

Dans cet appareil, cette sortie est verrouillée par le circuit IC504 (μ PD4028C ou TC4035BP), le code BCD est décodé par le circuit IC505 (μ PD4035C ou TC4035BP) en décimal, la diode électroluminescente qui indique l'adresse de canal préaccordé s'allume grâce au circuit IC506 (LB1274) pour que l'adresse du canal préaccordé soit affichée. La figure représente le circuit d'affichage de l'adresse du canal préaccordé.

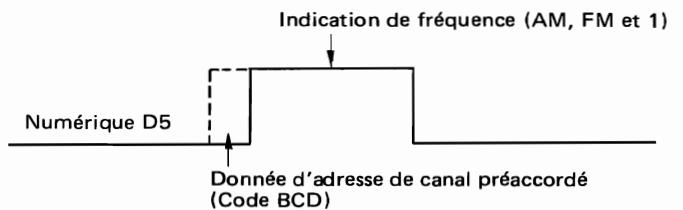
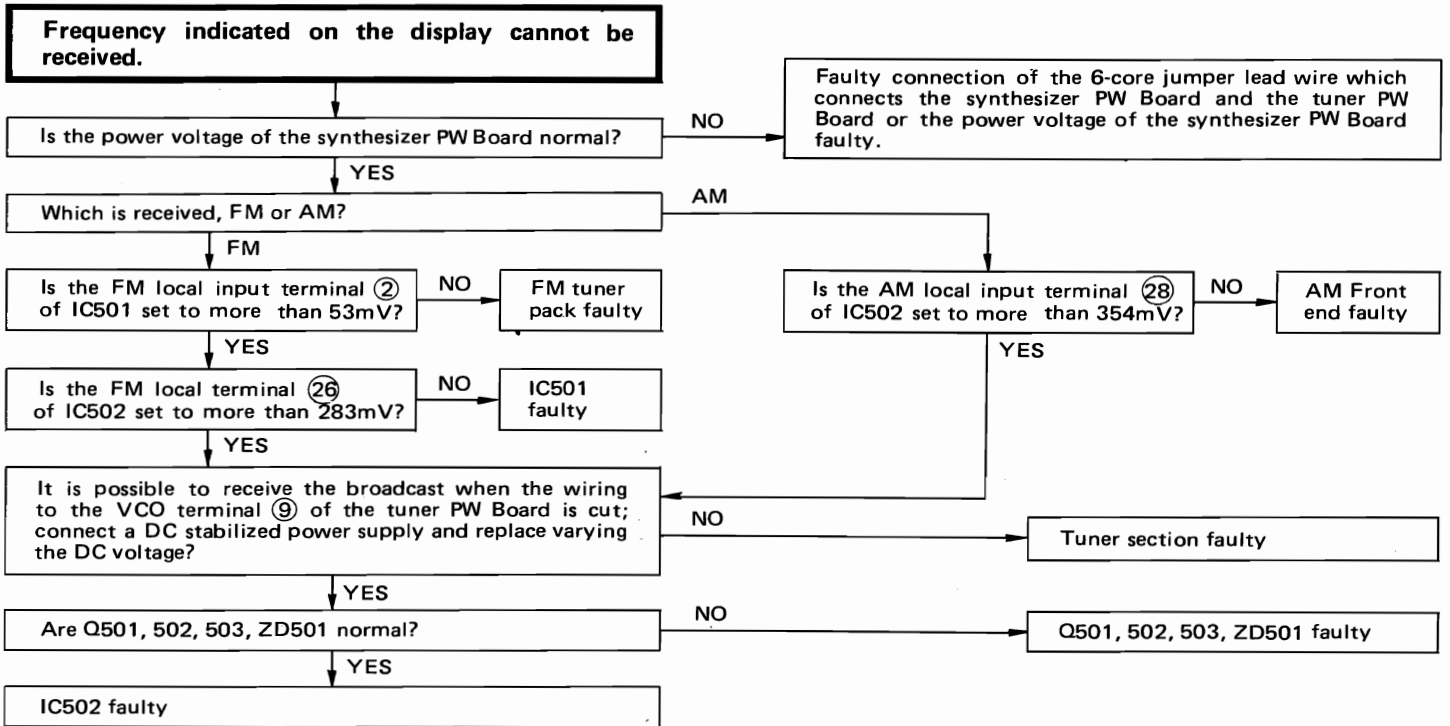
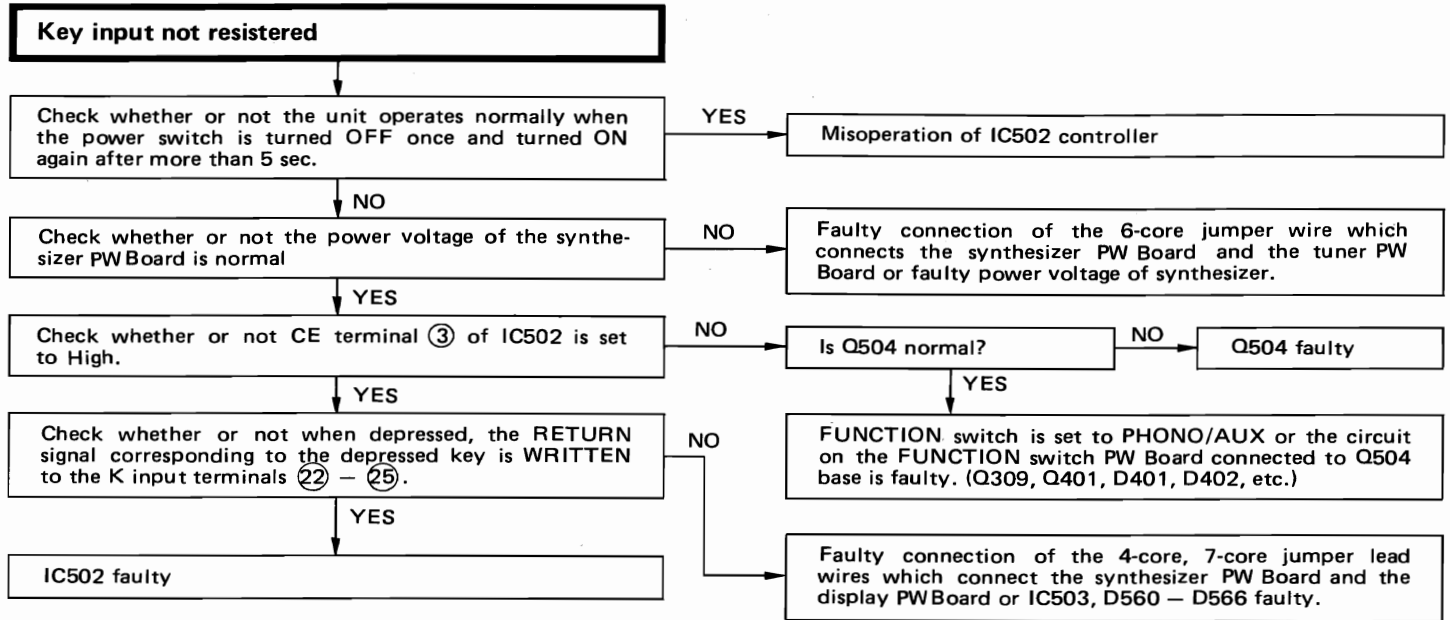

Figure 12 Représente le diagramme de synchronisation

Sg	Sf	Se	Canal préaccordé
0	0	1	P1
0	1	0	P2
0	1	1	P3
1	0	0	P4
1	0	1	P5
1	1	0	P6

Tableau 1 Sortie de code BCD du canal préaccordé

TROUBLE SHOOTING



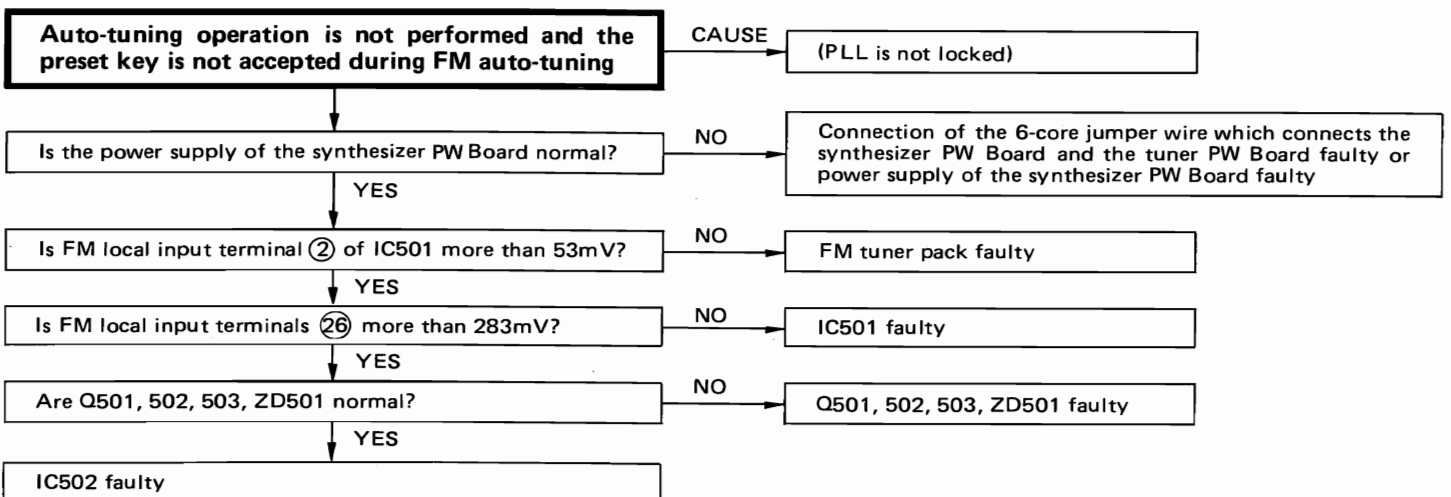
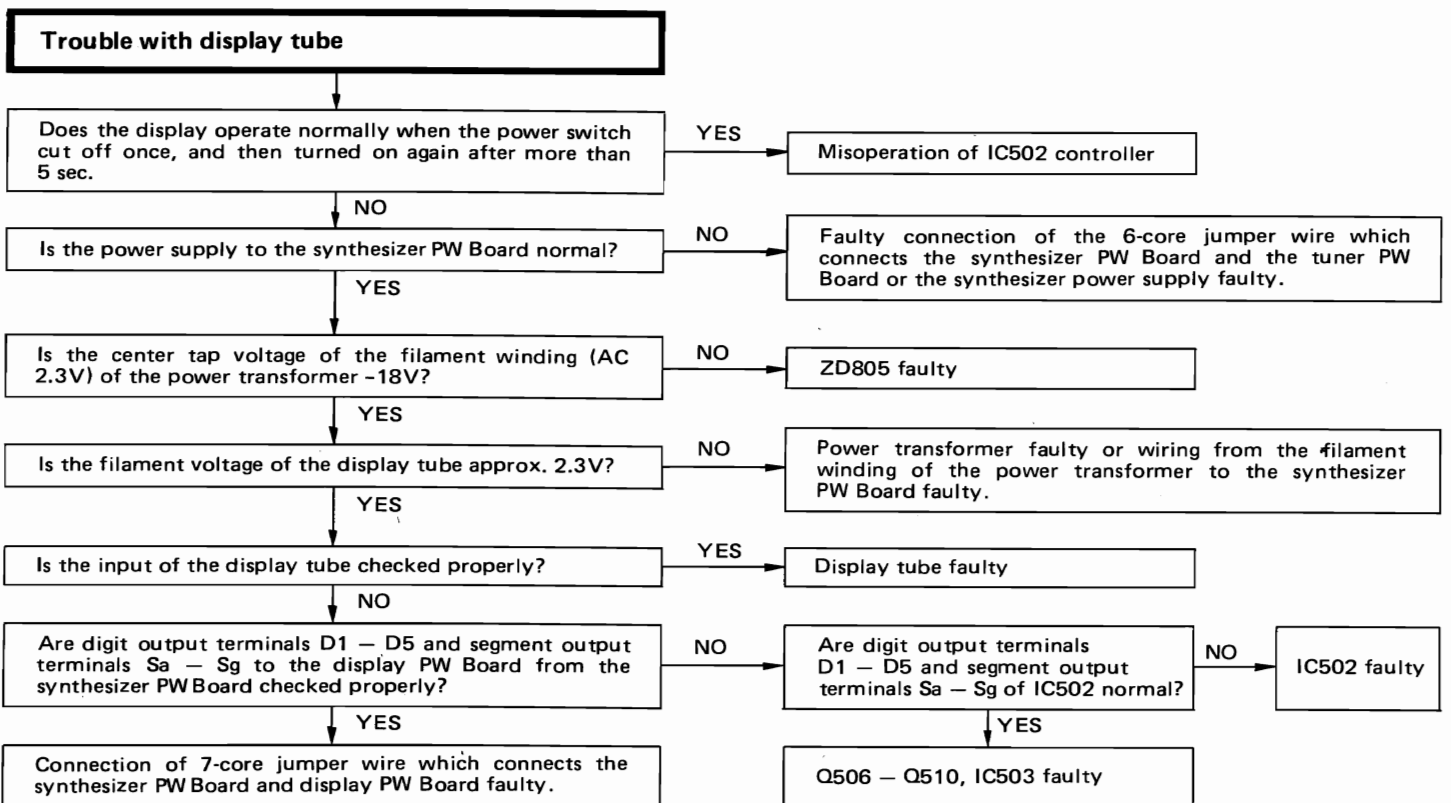
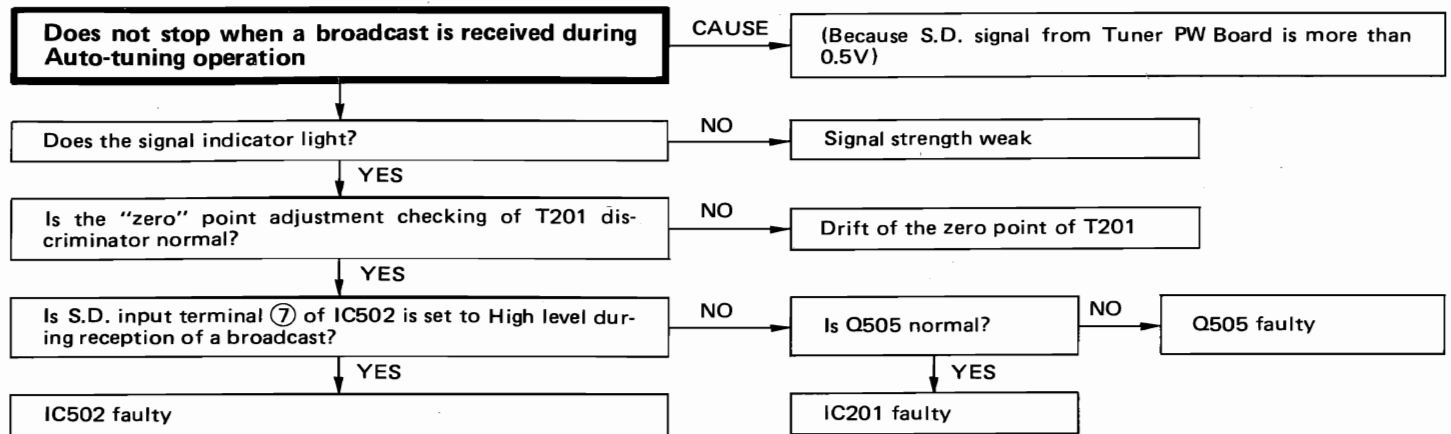

FEHLERSUCHE

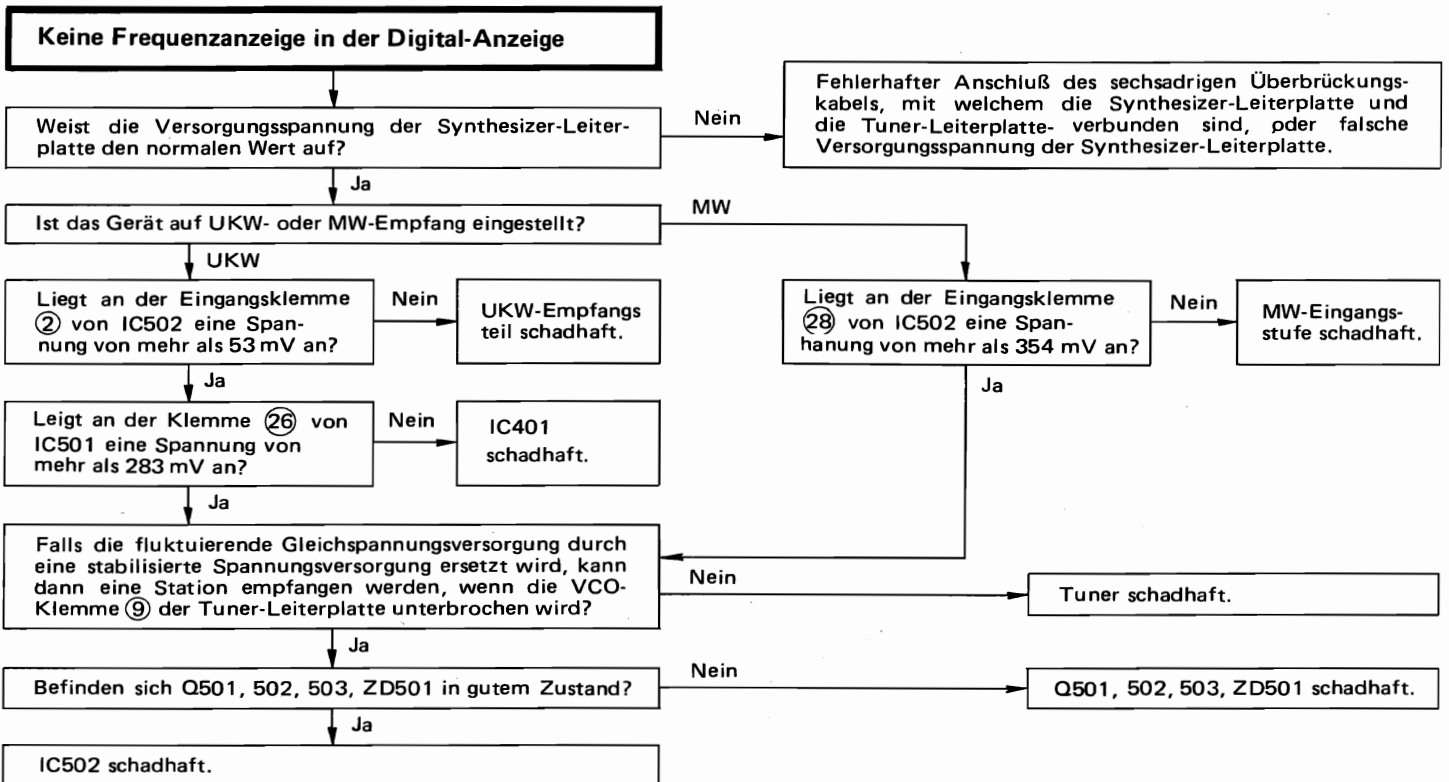
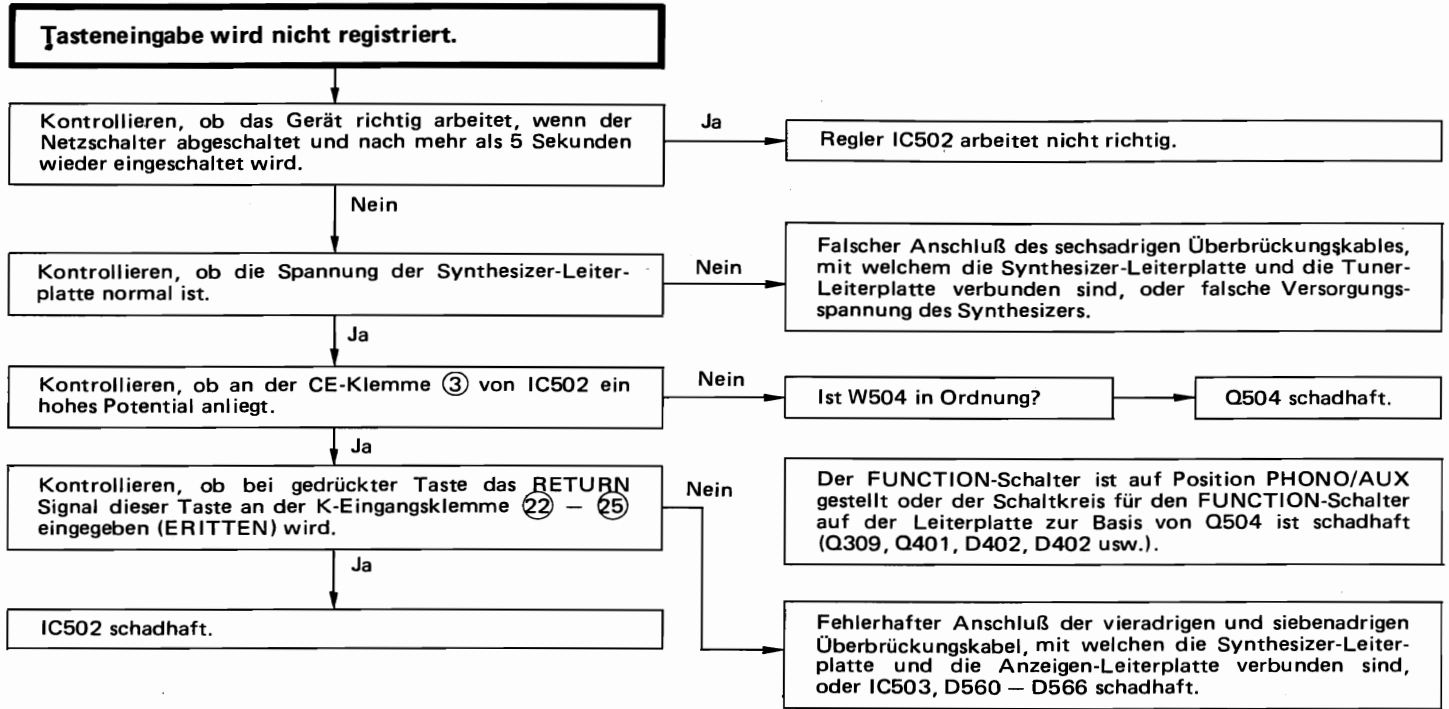

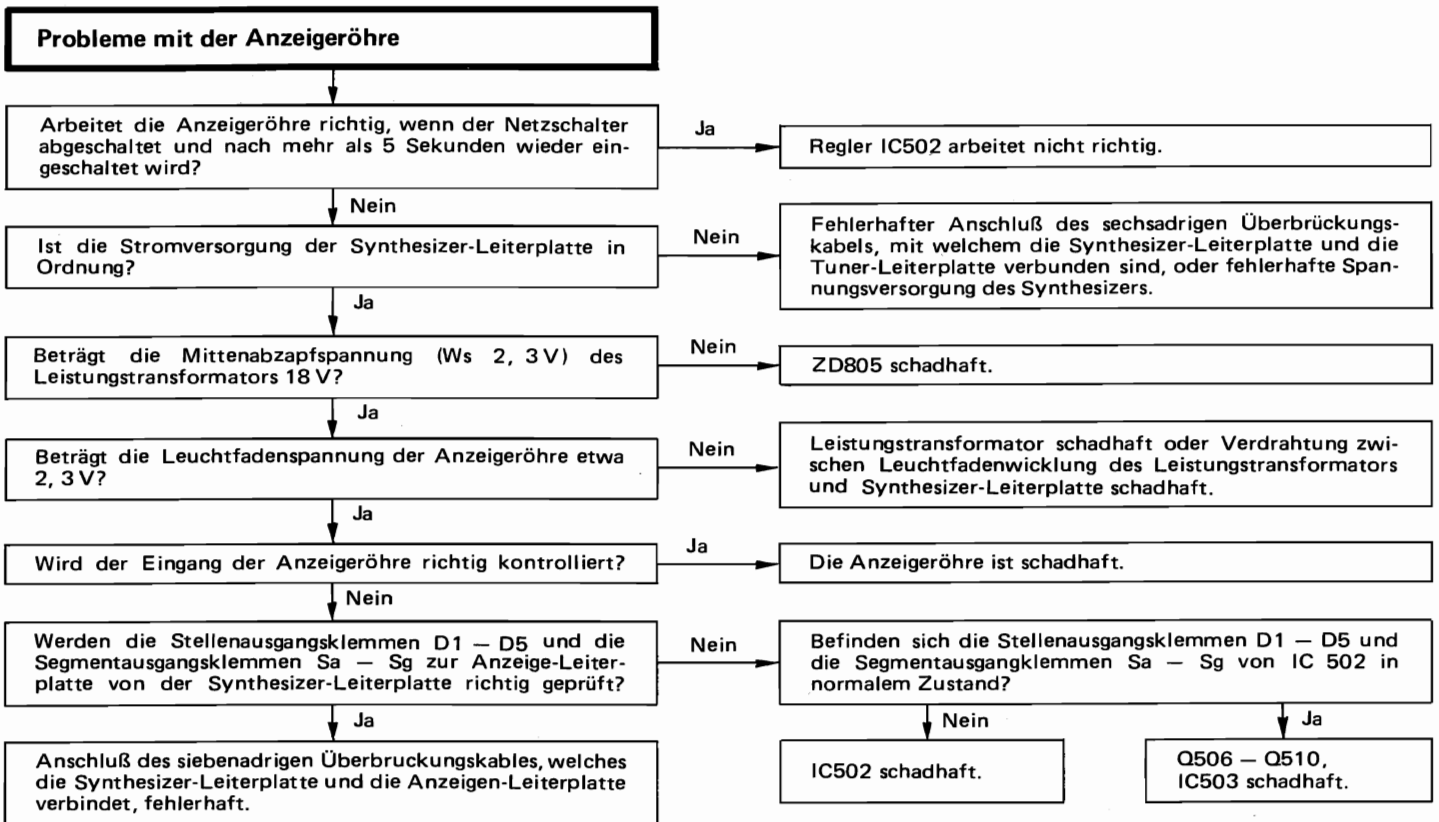
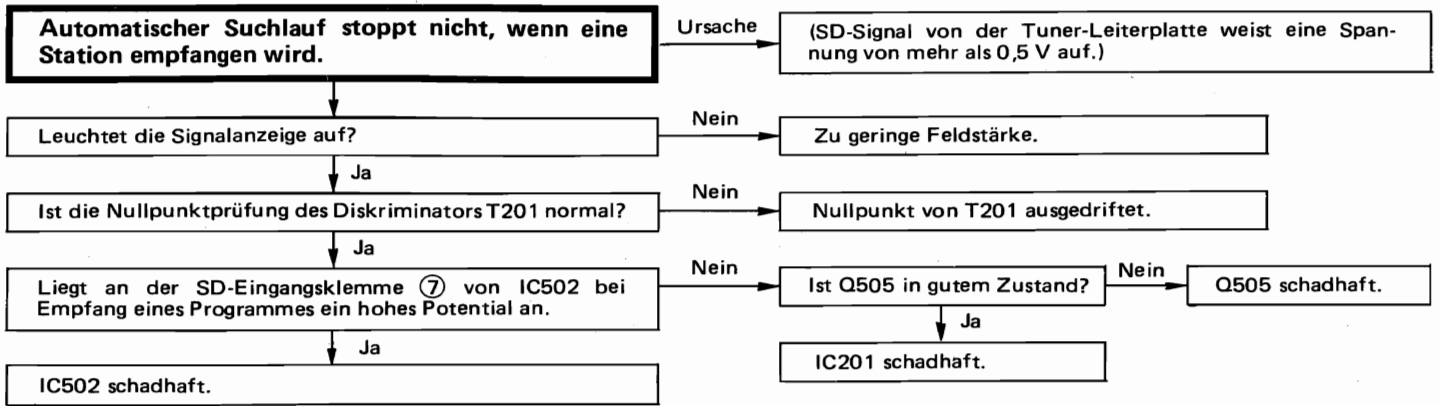

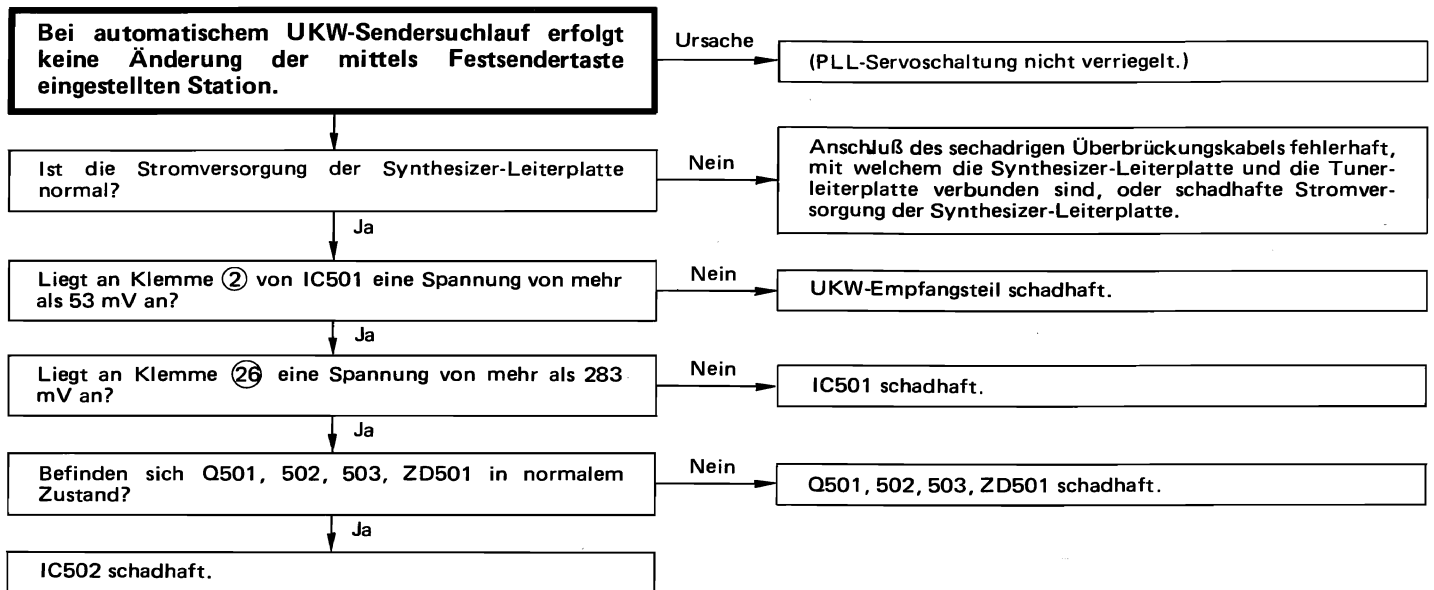

ANALYSE DE PANNES

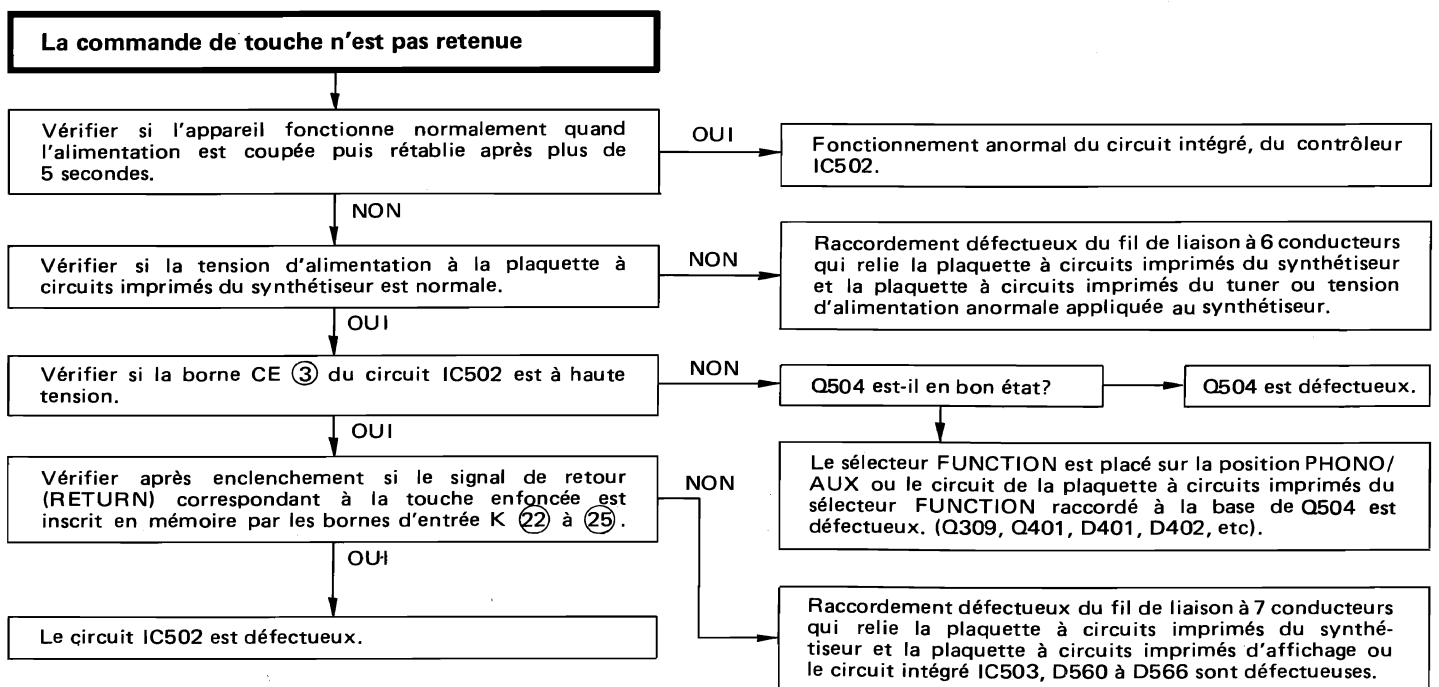

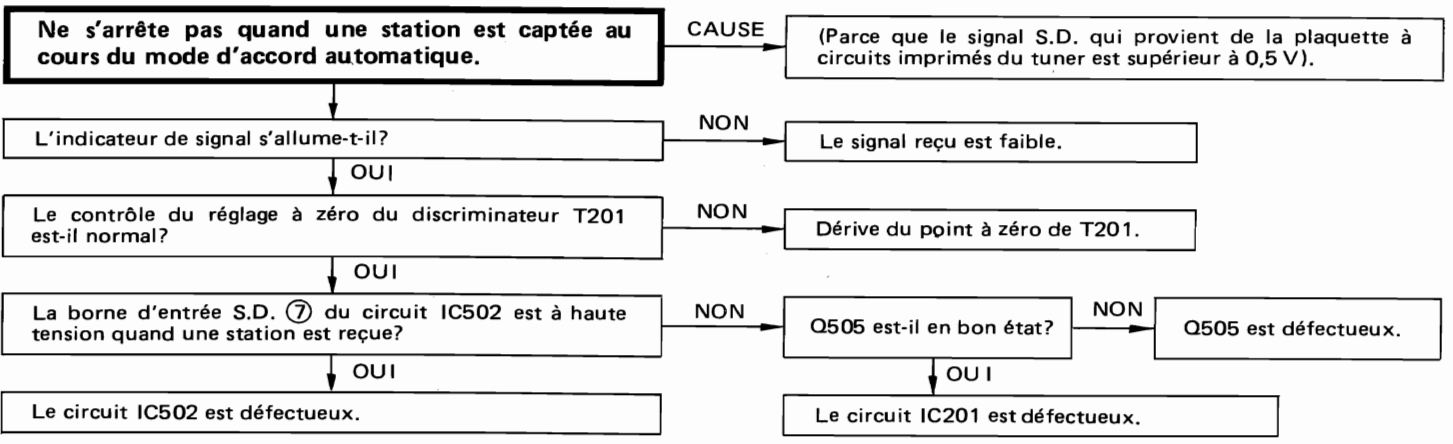
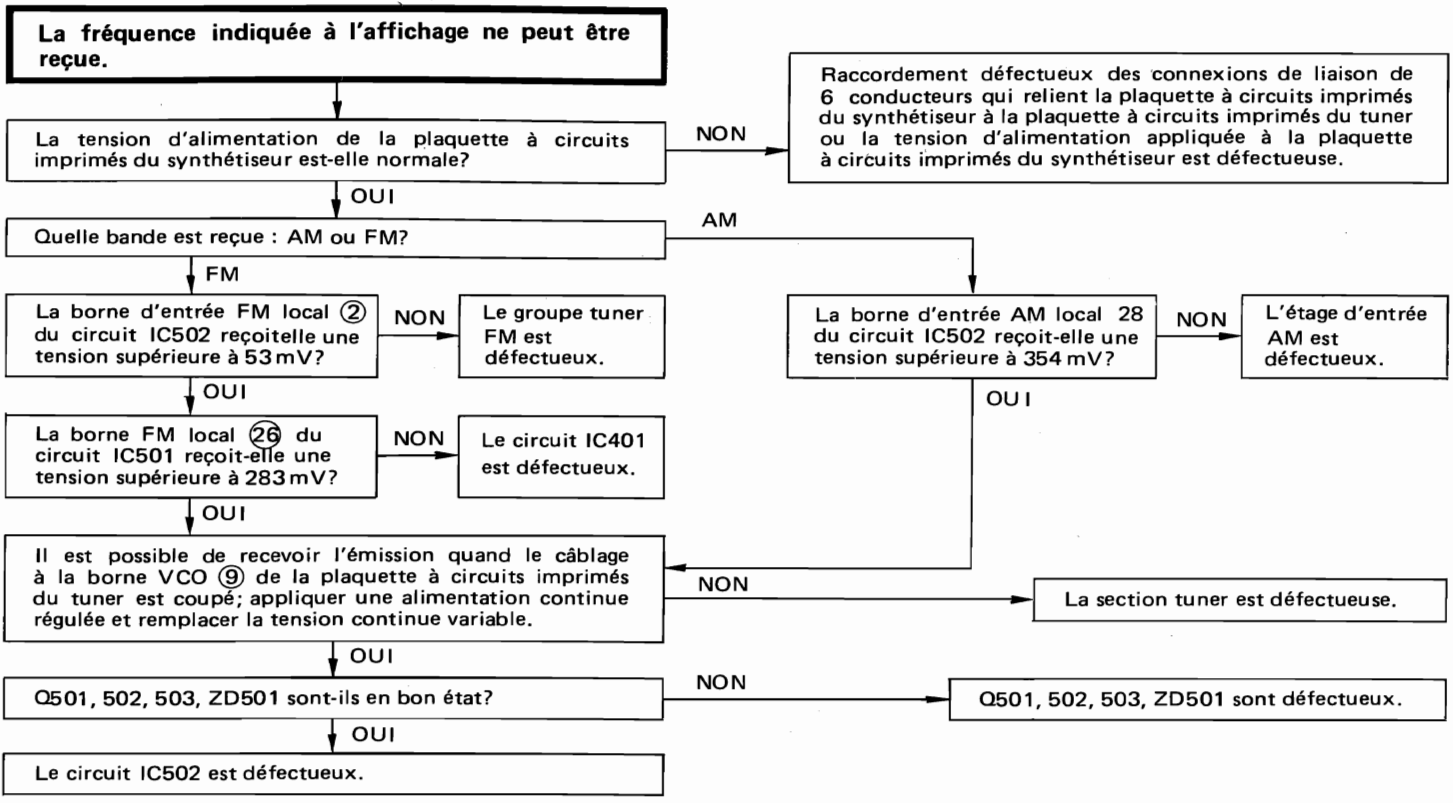

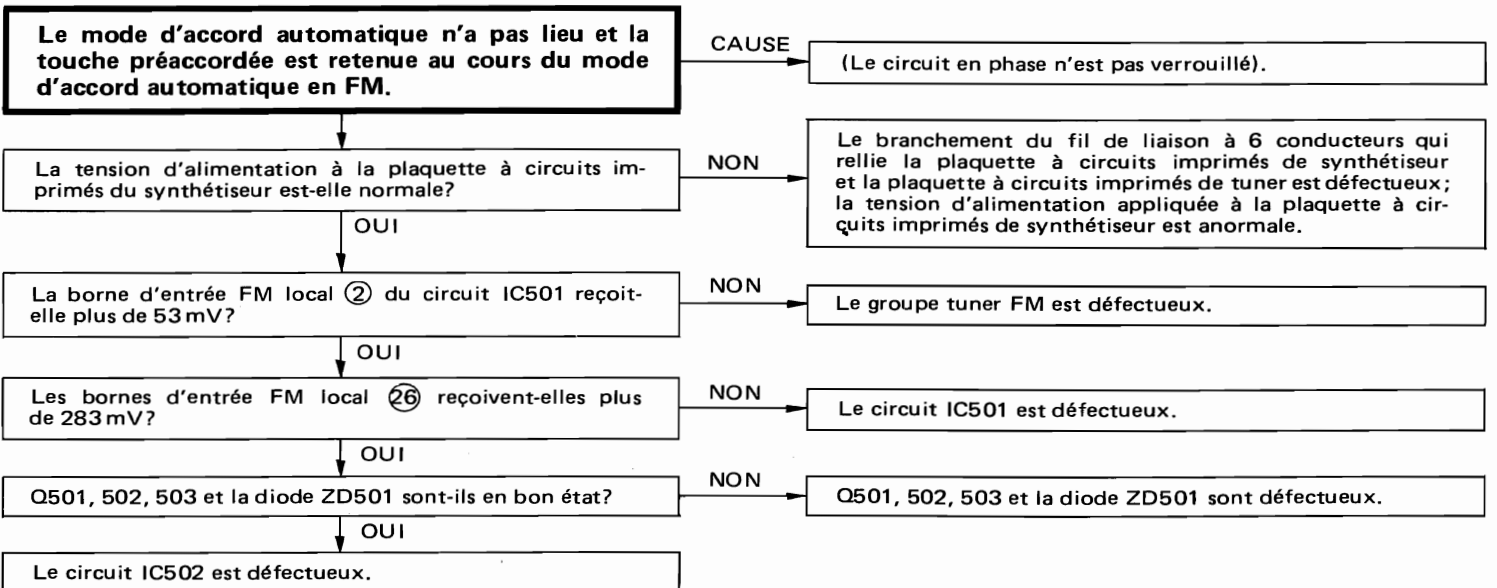
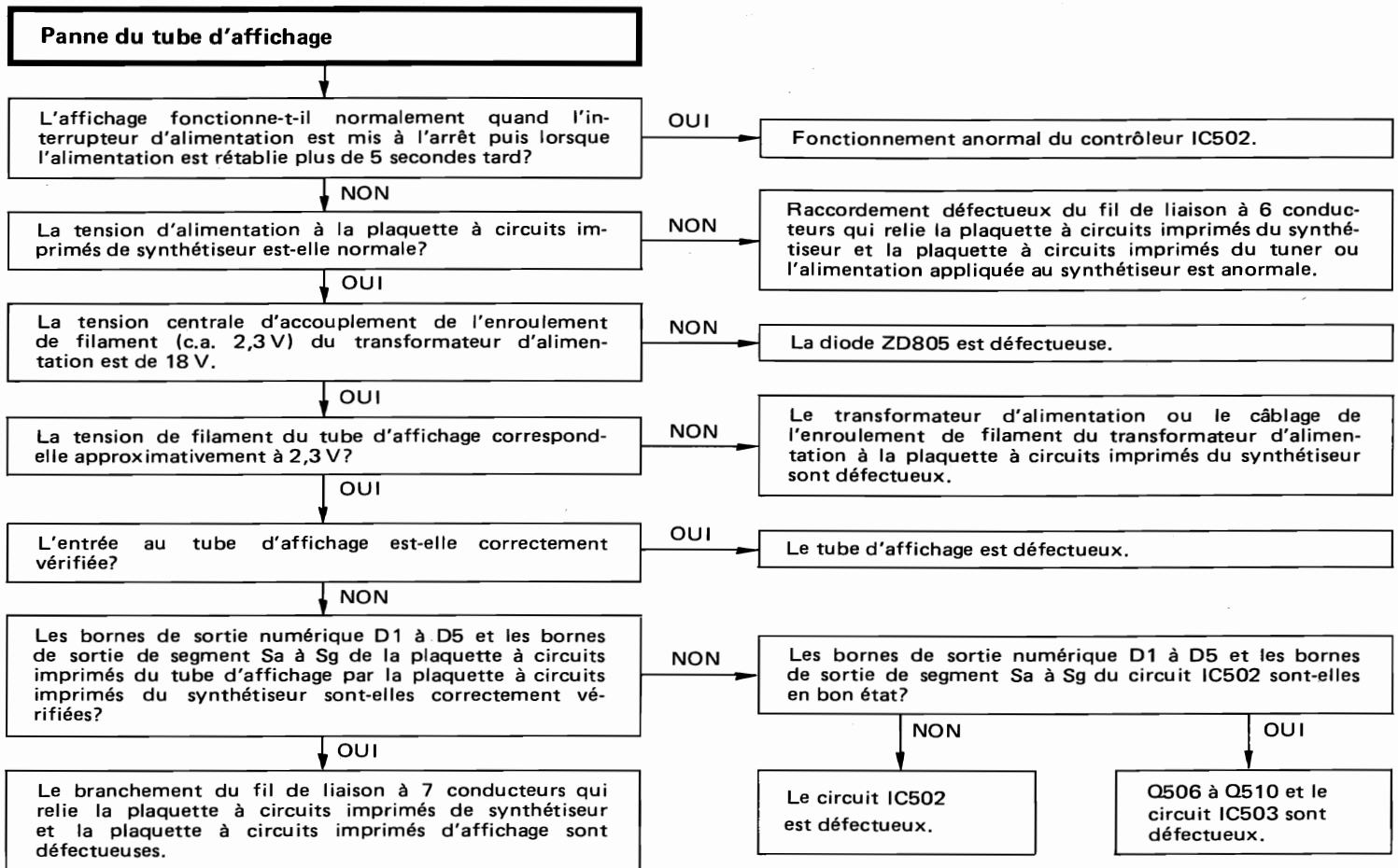

REPLACEMENT PARTS LIST·ERSATZTEILISTE·TABLEAU DES PIECE

SYMBOL No.	STOCK No.	DESCRIPTION			SYMBOL No.	STOCK No.	DESCRIPTION		
CAPACITORS									
for TUNER PRINTED WIRING BOARD									
C101	0276011	Mylar, film	0.1 μ F \pm 10%	50V	C303L,R	0274222	Mylar, film	1600pF \pm 5%	50V (for U.S.A. & Canada)
C102	0257162	Electrolytic	2.2 μ F	25V	C303L,R	0274221	Mylar, film	1100pF \pm 5%	50V (except U.S.A. & Canada)
C103	0252532	Electrolytic	220 μ F	16V	C304L,R	0252521	Electrolytic	10 μ F	16V
C104	H240108	Cylindrical ceramic	0.022 μ F \pm 30%	16V	C305	0228315	Styrol	150pF \pm 5%	50V
C105	H230073	Cylindrical ceramic	30pF \pm 5%	50V	C306L,R	0252521	Electrolytic	10 μ F	16V
C106	H230076	Cylindrical ceramic	39pF \pm 5%	50V	C307L,R	0252521	Electrolytic	10 μ F	16V
C107	H240108	Cylindrical ceramic	0.022 μ F \pm 30%	16V	C308L,R	0274223	Mylar, film	2400pF \pm 5%	50V (for U.S.A. & Canada)
C108	0252521	Electrolytic	10 μ F	16V	C308L,R	0274231	Mylar, film	1200pF \pm 5%	50V (except U.S.A. & Canada)
C109	H240108	Cylindrical ceramic	0.022 μ F \pm 30%	16V	C309	0252521	Electrolytic	10 μ F	16V
C110	H240108	Cylindrical ceramic	0.022 μ F \pm 30%	16V	C310	0252811	Electrolytic	1 μ F	50V
C151	H230112	Cylindrical ceramic	10pF \pm 5%	50V	C311	0252323	Electrolytic	33 μ F	10V
C152	0276011	Mylar, film	0.1 μ F \pm 10%	50V	C312	0252521	Electrolytic	10 μ F	16V
C153	H240106	Cylindrical ceramic	0.01 μ F \pm 30%	25V	C351	0252813	Electrolytic	3.3 μ F	50V
C154	H230062	Cylindrical ceramic	10pF \pm 5%	50V	C352	0252521	Electrolytic	10 μ F	16V
C155	0274011	Mylar, film	1000pF \pm 10%	50V	C353	0252522	Electrolytic	22 μ F	16V
C156	H240108	Cylindrical ceramic	0.022 μ F \pm 30%	16V	C354	0252521	Electrolytic	10 μ F	16V
C157	0252813	Electrolytic	3.3 μ F	50V	C355	0252521	Electrolytic	10 μ F	16V
C158	H240108	Cylindrical ceramic	0.022 μ F \pm 30%	16V	C357	0274013	Mylar, film	2200pF \pm 10%	50V
C159	H240108	Cylindrical ceramic	0.022 μ F \pm 30%	16V	C401L,R	0252813	Electrolytic	3.3 μ F	50V
C160	0228428	Styrol	510pF \pm 1%	50V	C402	0257182	Electrolytic	2.2 μ F	50V
C161	H230072	Cylindrical ceramic	27pF \pm 5%	50V	C403L,R	H230036	Cylindrical ceramic	100pF \pm 5%	50V
C162	H240106	Cylindrical ceramic	0.01 μ F \pm 30%	25V	C404L,R	0252231	Electrolytic	100 μ F	6.3V
C163	H240108	Cylindrical ceramic	0.022 μ F \pm 30%	16V	C405	0257182	Electrolytic	2.2 μ F	50V
C164	H240106	Cylindrical ceramic	0.01 μ F \pm 30%	25V	C406L,R	H230036	Cylindrical ceramic	100pF \pm 5%	50V
C165	H240106	Cylindrical ceramic	0.01 μ F \pm 30%	25V	C407L,R	H240008	Cylindrical ceramic	470pF \pm 10%	50V
C166	H240108	Cylindrical ceramic	0.022 μ F \pm 30%	16V	C408L,R	0252813	Electrolytic	3.3 μ F	50V
C167	0246412	Ceramic, discal	2pF \pm 0.25pF	50V	C409L,R	0274236	Mylar, film	8200pF \pm 5%	50V
C201	H240108	Cylindrical ceramic	0.022 μ F \pm 30%	16V	C410L,R	0274213	Mylar, film	2200pF \pm 5%	50V
C202	0244185	Ceramic, discal	0.047 μ F \pm 8%	50V	C411L,R	H230036	Cylindrical ceramic	100pF \pm 5%	50V
C203	0244185	Ceramic, discal	0.047 μ F \pm 8%	50V	C412L,R	0274214	Mylar, film	3300pF \pm 5%	50V
C204	H240108	Cylindrical ceramic	0.022 μ F \pm 30%	16V	C413	0252231	Electrolytic	100 μ F	6.3V
C205	H240108	Cylindrical ceramic	0.022 μ F \pm 30%	16V	C414	H240108	Cylindrical ceramic	0.022 μ F \pm 30%	16V
C206	0252876	Electrolytic	0.68 μ F	50V	C415	0244173	Ceramic, discal	0.022 μ F \pm 8%	50V
C207	H240108	Cylindrical ceramic	0.022 μ F \pm 30%	16V	C601L,R	H240003	Cylindrical ceramic	180pF \pm 10%	50V
C209	0275015	Mylar, film	0.047 μ F \pm 10%	50V	C602L,R	0275233	Mylar, film	0.027 μ F \pm 5%	50V
C211	0245018	Ceramic, discal	0.022 μ F \pm 8%	25V	C603L,R	0276211	Mylar, film	0.1 μ F \pm 5%	50V
C212	0252811	Electrolytic	1 μ F	50V	C604L,R	0276211	Mylar, film	0.1 μ F \pm 5%	50V
C213	H240108	Cylindrical ceramic	0.022 μ F \pm 30%	16V	C605L,R	0252811	Electrolytic	1 μ F	50V
C214	0252875	Electrolytic	0.47 μ F	50V	C606L,R	0252521	Electrolytic	10 μ F	16V
C215	H240108	Cylindrical ceramic	0.022 μ F \pm 30%	16V	C607L,R	0252521	Electrolytic	10 μ F	16V
C216	0252525	Electrolytic	47 μ F	16V	C608L,R	H230036	Cylindrical ceramic	100pF \pm 5%	50V
C217	H240108	Cylindrical ceramic	0.022 μ F \pm 30%	16V	C609L,R	H240008	Cylindrical ceramic	470pF \pm 10%	50V
C251	0246486	Ceramic, discal	47pF \pm 0.5pF	50V	C610L,R	0252522	Electrolytic	22 μ F	16V
C252	H240008	Cylindrical ceramic	470pF \pm 10%	50V	C611L,R	H230037	Cylindrical ceramic	120pF \pm 5%	50V
C253	H240108	Cylindrical ceramic	0.022 μ F \pm 30%	16V	C612L,R	0274215	Mylar, film	4700pF \pm 5%	50V
C254	0252812	Electrolytic	2.2 μ F	50V	C613L,R	0275233	Mylar, film	0.027 μ F \pm 5%	50V
C255	0252813	Electrolytic	3.3 μ F	50V	C614L,R	H240003	Cylindrical ceramic	180pF \pm 10%	50V
C256	H240106	Cylindrical ceramic	0.01 μ F \pm 30%	25V	C615L,R	0275234	Mylar, film	0.039 μ F \pm 5%	50V
C257	H240108	Cylindrical ceramic	0.022 μ F \pm 30%	16V	C616L,R	0276213	Mylar, film	0.22 μ F \pm 5%	50V
C258	H240108	Cylindrical ceramic	0.022 μ F \pm 30%	16V	C617L,R	H230024	Cylindrical ceramic	33pF \pm 5%	50V
C259	0275015	Mylar, film	0.047 μ F \pm 10%	50V	C618	0257182	Electrolytic	2.2 μ F	50V
C260	0252811	Electrolytic	1 μ F	50V	C619	0257182	Electrolytic	2.2 μ F	50V
C261	0274036	Mylar, film	8200pF \pm 10%	50V	C814	0252525	Electrolytic	47 μ F	16V
C301	0252521	Electrolytic	10 μ F	16V	C815	0252531	Electrolytic	100 μ F	16V
C302	0252535	Electrolytic	470 μ F	16V					

HITACHI HTA-7000

SYMBOL No.	STOCK No.	DESCRIPTION			SYMBOL No.	STOCK No.	DESCRIPTION				
for MAIN AMPLIFIER PRINTED WIRING BOARD											
C501	0274011	Mylar, film	1000pF ±10%	50V	R102	H129603	Carbon film	1.2kΩ ±5%	SRD1/8P		
C502	0279309	Mylar, film	2.2μF ±10%	100V	R103	H129631)	10kΩ ±5%)		
C503	0252525	Electrolytic	47μF	16V	R104	H129661		100kΩ ±5%			
C504	0252225	Electrolytic	47μF	6.3V	R105	H129651		68kΩ ±5%			
C505	0245018	Ceramic, discal	0.022μF ±80%	25V	R106	H129649		56kΩ ±5%			
C506	0245017	Ceramic, discal	0.01μF ±80%	25V	R107	H129631		10kΩ ±5%			
C507	0246449	Ceramic, discal	24pF ±5%	50V	R108	H129635		15kΩ ±5%			
C508	0246449	Ceramic, discal	24pF ±5%	50V	R109	H129635		15kΩ ±5%		SRD1/8P	
C509	0245018	Ceramic, discal	0.022μF ±80%	25V	R151	H129631		Carbon film		10kΩ ±5%	SRD1/8P
C510	0252232	Electrolytic	220μF	6.3V	R152	H129631)		10kΩ ±5%)
C511	0252722	Electrolytic	22μF	35V	R153	H129677	470kΩ ±5%				
C512	0248736	Ceramic, discal	330pF ±10%	50V	R154	H129607	1.8kΩ ±5%				
C513	0252522	Electrolytic	22μF	16V	R155	H129631	10kΩ ±5%				
C514	0252232	Electrolytic	220μF	6.3V	R156	H129639	22kΩ ±5%				
C701L,R	0252811	Electrolytic	1μF	50V	R157	H129649	56kΩ ±5%				
C702	0252522	Electrolytic	22μF	16V	R158	H129621	6.8kΩ ±5%				
C703	0252522	Electrolytic	22μF	16V	R159	H129549	56kΩ ±5%				
C704L,R	0257144	Electrolytic	4.7μF	16V	R160	H129603	1.2kΩ ±5%				
C705L,R	H230036	Cylindrical ceramic	100pF ±5%	50V	R161	H129663	120kΩ ±5%				
C706L,R	H230036	Cylindrical ceramic	100pF ±5%	50V	R162	H129605	1.5kΩ ±5%				
C707L,R	H230020	Cylindrical ceramic	22pF ±5%	50V	R163	H129669	220kΩ ±5%				
C708L,R	H230020	Cylindrical ceramic	22pF ±5%	50V	R164	H129609	Carbon film	2.2kΩ ±5%	SRD1/8P		
C709L,R	0275011	Mylar, film	0.01μF ±10%	50V	R166	H129663	Carbon film	120kΩ ±5%	SRD1/8P		
C710L,R	0276013	Mylar, film	0.22μF ±10%	50V	R167	H129631)	10kΩ ±5%)		
C711	0276012	Mylar, film	0.15μF ±10%	50V	R168	H129601		1kΩ ±5%			
C712	0276012	Mylar, film	0.15μF ±10%	50V	R169	H129565)	150Ω ±5%)		
C713L,R	H230003	Cylindrical ceramic	1.8pF ±5%	50V	R170	H129569		Carbon film		220Ω ±5%	SRD1/8P
C714L,R	0247839	Ceramic, discal	24pF ±5%	500V							
C801	0245408	Ceramic, discal	0.01μF ±20%	500V	R202	H129549	Carbon film	56Ω ±5%	SRD1/8P		
C802	0245408	Ceramic, discal	0.01μF ±20%	500V	R203	H129575)	390Ω ±5%)		
C803	0259927	Electrolytic	10,000μF	50V	R204	H129575		390Ω ±5%			
C804	0259927	Electrolytic	10,000μF	50V	R205	H129575		390Ω ±5%			
C805	0252521	Electrolytic	10μF	16V	R206	H129619	Carbon film	5.6kΩ ±5%	SRD1/8P		
C806	0252825	Electrolytic	47μF	50V	R207	H129601	Carbon film	1kΩ ±5%	SRD1/8P		
C809	0252825	Electrolytic	47pF	50V	ΔR208	0110608	Metal (fuse resistor)	39Ω ±5%	RN1/4B		
C810	0245801	Ceramic, discal	0.01μF ±20%	50V	R209	H129575	Carbon film	390Ω ±5%	SRD1/8P		
C811	0245801	Ceramic, discal	0.01μF ±20%	50V	R210	H129651)	68kΩ ±5%)		
C812	0252741	Electrolytic	1000μF	35V	R211	H129635		15kΩ ±5%			
C813	0252625	Electrolytic	47μF	25V	R212	H129613		3.3kΩ ±5%			
C816	0245408	Ceramic, discal	0.01μF ±20%	500V	R213	H129609		2.2kΩ ±5%			
C901	0252231	Electrolytic	100μF	6.3V	R214	H129631		10kΩ ±5%			
C902	0252521	Electrolytic	10μF	16V	R215	H129661		100kΩ ±5%			
C903	0252811	Electrolytic	1μF	50V	R216	H129641		27kΩ ±5%			
C904	0252232	Electrolytic	220μF	6.3V	R217	H129611		2.7kΩ ±5%			
C905	0252232	Electrolytic	220μF	6.3V	R218	H129561		100Ω ±5%			
ΔC001	0243901	Ceramic, discal	0.01μF ±10% 400V (except U.S.A. & Canada)		R219	H129619		5.6kΩ ±5%			
ΔC002	0243901	Ceramic, discal	0.01μF ±10% 400V (except U.S.A. & Canada)		R220	H129623	Carbon film	8.2kΩ ±5%	SRD1/8P		
ΔC002	0243899	Ceramic, discal	0.01μF ±10% 125V (for U.S.A. & Canada)		ΔR221	0110610	Metal (fuse resistor)	56Ω ±5%	RN1/4B		
					R222	H129623	Carbon film	8.2kΩ ±5%	SRD1/8P		
								(for U.S.A. & Canada)			
					R223	H129631	Carbon film	10kΩ ±5%	SRD1/8P		
								(except U.S.A. & Canada)			
					R251	H129609	Carbon film	2.2kΩ ±5%	SRD1/8P		
					R252	H129643)	33kΩ ±5%)		
					R253	H129631		10kΩ ±5%			
					R254	H129669		Carbon film		220kΩ ±5%	SRD1/8P
RESISTORS											
for TUNER PRINTED WIRING BOARD											
R101	H129661	Carbon film	100kΩ ±5%	SRD1/8P	R256	H129665	Carbon film	150kΩ ±5%	SRD1/8P		
					R257	H129609)	2.2kΩ ±5%)		
					R258	H129619		5.6kΩ ±5%			

SYMBOL No.	STOCK No.	DESCRIPTION			SYMBOL No.	STOCK No.	DESCRIPTION				
R259	H129665	Carbon film	150kΩ ±5%	SRD1/8P	R425	H129651	Carbon film	68kΩ ±5%	SRD1/8P		
R260	H129641	}	27kΩ ±5%	}	R426	H129643	}	33kΩ ±5%	}		
R261	H129615		3.9kΩ ±5%								
R262	H129601		1kΩ ±5%								
R263	H129645		39kΩ ±5%								
R264	H129631		10kΩ ±5%								
R265	H129561	Carbon film	100Ω ±5%	SRD1/8P	R428	H129631	Carbon film	10kΩ ±5%	SRD1/8P		
R301	H129641	Carbon film	27kΩ ±5%	SRD1/8P	R601L,R	H129651	Carbon film	68kΩ ±5%	SRD1/8P		
△R302	0110612	Metal (fuse resistor)	82Ω ±5%	RN1/4B	R602L,R	H129639	Carbon film	22kΩ ±5%	SRD1/8P		
R304L,R	H129607	Carbon film	1.8kΩ ±5%	SRD1/8P	R604L,R	H129701	Carbon film	1MΩ ±5%	SRD1/8P		
R305L,R	H129631	}	10kΩ ±5%	}	R605L,R	H129663	}	120kΩ ±5%	}		
R306L,R	H129613		3.3kΩ ±5%								
R307L,R	H129613		Carbon film		3.3kΩ ±5%	SRD1/8P		R606L,R		H129647	47kΩ ±5%
R309	H129611		Carbon film		2.7kΩ ±5%	SRD1/8P		R607L,R		H129643	33kΩ ±5%
R310	H129661		}		100kΩ ±5%	}		R608L,R		H129637	18kΩ ±5%
R311	H129609	2.2kΩ ±5%									
R312	H129661	Carbon film	100kΩ ±5%	SRD1/8P	R609L,R	H129647	4.7kΩ ±5%				
R316	H129661	Carbon film	100kΩ ±5%	SRD1/8P	R610L,R	H129605	1.5kΩ ±5%				
R317	H129611	}	2.7kΩ ±5%	}	R611L,R	H129617	47kΩ ±5%				
R318	H129553		82Ω ±5%								
R319	H129661		100kΩ ±5%								
R320	H129647		47kΩ ±5%								
R321	H129649		56kΩ ±5%								
R322	H129649	56kΩ ±5%									
R323	H129661	100kΩ ±5%									
R324	H129601	1kΩ ±5%									
R325	H129661	100kΩ ±5%									
R326	H129639	Carbon film	22kΩ ±5%	SRD1/8P	R612L,R	H129633	12kΩ ±5%				
R351	H129635	Carbon film	15kΩ ±5%	SRD1/8P	R613L,R	H129607	1.8kΩ ±5%				
R352	H129653	Carbon film	82kΩ ±5%	SRD1/8P	R614L,R	H129617	Carbon film	4.7kΩ ±5%	SRD1/8P		
R353	H129631	Carbon film	10kΩ ±5%	SRD1/8P	R616L,R	H129581	Carbon film	680Ω ±5%	SRD1/8P		
R355	H129631	Carbon film	10kΩ ±5%	SRD1/8P	R617L,R	H129619	5.6kΩ ±5%				
△R356	0110609	Metal (fuse resistor)	47Ω ±5%	RN1/4B	R618L,R	H129583	820Ω ±5%				
R357	H129551	Carbon film	68Ω ±5%	SRD1/8P	R619L,R	H129633	Carbon film	12kΩ ±5%	SRD1/8P		
R361	H129551	Carbon film	68Ω ±5%	SRD1/8P	R621L,R	H129607	Carbon film	1.8kΩ ±5%	SRD1/8P		
R401L,R	H129673	Carbon film	330kΩ ±5%	SRD1/8P	△R815	0110611	Metal (fuse resistor)	68Ω ±5%	RN1/4B		
R402L,R	H129577	}	470Ω ±5%	}	R816	0114165	Carbon film	1.5kΩ ±5%	SRD1/4P		
R403L,R	H129649		56kΩ ±5%								
R404L,R	H129581		680Ω ±5%								
R405L,R	H129647		47kΩ ±5%								
R406L,R	H129605		1.5kΩ ±5%								
R407L,R	H129675		390kΩ ±5%								
R408L,R	H129643		33kΩ ±5%								
R409L,R	H129577		470Ω ±5%								
R410L,R	H129661		100kΩ ±5%								
R411L,R	H129583		820Ω ±5%								
R412L,R	H129583		820Ω ±5%								
R413L,R	H129675		390kΩ ±5%								
R414L,R	H129583		820Ω ±5%								
R415L,R	H129675		390kΩ ±5%								
R416L,R	H129671		270kΩ ±5%								
R417L,R	H129663	Carbon film	120kΩ ±5%	SRD1/8P	R817	0114147	470Ω ±5%	SRD1/4P			
R419	0114165	Carbon film	1.5kΩ ±5%	SRD1/4P	R818	H129661	100kΩ ±5%	SRD1/8P			
R424	0114165	Carbon film	1.5kΩ ±5%	SRD1/4P	R819	H129639	22kΩ ±5%	}			
					R820	H129631	10kΩ ±5%				
					R821	H129605	1.5kΩ ±5%				
					R822	H129631	10kΩ ±5%				
for MAIN AMPLIFIER PRINTED WIRING BOARD											
					R501	H129635	Carbon film	15kΩ ±5%	SRD1/8P		
					R502	H129611	}	2.7kΩ ±5%	}		
					R503	H129621		6.8kΩ ±5%			
					R504	H129581		680Ω ±5%			
					R505	H129605		1.5kΩ ±5%			
					R506	H129633		12kΩ ±5%			
					R507	H129661		100kΩ ±5%			
					R508	H129631		10kΩ ±5%			
					R509	H129631		10kΩ ±5%			
					R510	H129649		Carbon film		56kΩ ±5%	SRD1/8P
					R514	H129649		Carbon film		56kΩ ±5%	SRD1/8P
					R515	H129631	Carbon film	10kΩ ±5%	SRD1/8P		
					R521	H129631	Carbon film	10kΩ ±5%	SRD1/8P		
					R523	H129669	Carbon film	220kΩ ±5%	SRD1/8P		
					R526	}	}	220kΩ ±5%	SRD1/8P		
					R527			220kΩ ±5%	SRD1/8P		
					R528			H129669	Carbon film	220kΩ ±5%	SRD1/8P
								(for U.S.A. & Canada)			
					R529	H129669	Carbon film	220kΩ ±5%	SRD1/8P		
					R532	H129669	Carbon film	220kΩ ±5%	SRD1/8P		
								(for Asia & Latin American countries, etc.)			

SYMBOL No.	STOCK No.	DESCRIPTION			SYMBOL No.	STOCK No.	DESCRIPTION		
R533	H129661	Carbon film	100kΩ ±5%	SRD1/8P	△ R746L,R	0110628	Metal (fuse resistor)	390Ω ±5%	RN1/4B
R534	H129649)	56kΩ ±5%)	△ R747L,R	0110601	Metal (fuse resistor)	10Ω ±5%	RN1/4B
R535	H129661		100kΩ ±5%						
R536	H129623		8.2kΩ ±5%						
R537	H129609		2.2kΩ ±5%						
R538	H129631		10kΩ ±5%						
R539	H129569	Carbon film	220Ω ±5%	SRD1/8P	R801	0134380	Composition	3.9kΩ ±10%	RC1/2GF
R551	H129511	Carbon film	2.7Ω ±5%	SRD1/8P	R802	0114183	Carbon film	8.2kΩ ±5%	SRD1/4P
R552	H129511)	2.7Ω ±5%)	R803	0114173)	3.3kΩ ±5%)
R553	H129567		180Ω ±5%						
R558	H129567		180Ω ±5%						
R559	H129511		2.7Ω ±5%						
R560	H129511		Carbon film		2.7Ω ±5%	SRD1/8P		R804	
R701L,R	H129615	Carbon film	3.9kΩ ±5%	SRD1/8P	R805	0114173	3.3kΩ ±5%		
R702L,R	H129641)	27kΩ ±5%)	R806	0114183	8.2kΩ ±5%		
R703L,R	H129649		56kΩ ±5%						
R704L,R	H129677		470kΩ ±5%						
R705	H129577		470Ω ±5%						
R706	H129577		Carbon film		470Ω ±5%	SRD1/8P	R807	0114173	3.3kΩ ±5%
R708	H129619	Carbon film	5.6kΩ ±5%	SRD1/8P	R808	0114183	8.2kΩ ±5%		
R709	0134382	Composition	5.6kΩ ±10%	RC1/2GF	R809	0114201	10kΩ ±5%		
R710	0134382	Composition	5.6kΩ ±10%	RC1/2GF	R810	0114205	15kΩ ±5%		
R712L,R	H129647	Carbon film	47kΩ ±5%	SRD1/8P	R811	0114165	1.5kΩ ±5%		
R713L,R	H129647)	47kΩ ±5%)	R812	0114201	Carbon film	10kΩ ±5%	SRD1/4P
R714L,R	H129623		8.2kΩ ±5%						
R715L,R	H129607		1.8kΩ ±5%						
R716L,R	H129607		1.8kΩ ±5%						
R717L,R	H129665		150kΩ ±5%						
R718L,R	H129603	1.2kΩ ±5%							
R719L,R	H129639	Carbon film	22kΩ ±5%	SRD1/8P	R813	0134377	Composition	2.2kΩ ±5%	RC1/2GF
△ R720L,R	0110611	Metal (fuse resistor)	68Ω ±5%	RN1/4B	△ R825	0110601	Metal (fuse resistor)	10Ω ±5%	RN1/4B
R721L,R	0114183	Carbon film	8.2kΩ ±5%	SRD1/4P	△ R826	0110601	Metal (fuse resistor)	10Ω ±5%	RN1/4B
△ R722L,R	0110621	Metal (fuse resistor)	100Ω ±5%	RN1/4B	R901	0119542	Metal oxide	1.2kΩ ±10%	RS2B
△ R723L,R	0110611	Metal (fuse resistor)	68Ω ±5%	RN1/4B	R902	0119446	Metal oxide	2.7kΩ ±10%	RS1B
R724L,R	H129617	Carbon film	4.7kΩ ±5%	SRD1/8P	R903	H129647	Carbon film	47kΩ ±5%	SRD1/8P
R725L,R	H129617	Carbon film	4.7kΩ ±5%	SRD1/8P	R904	H129661)	100kΩ ±10%)
△ R727L,R	0110626	Metal (fuse resistor)	270Ω ±5%	RN1/4B	R905	H129651		68kΩ ±5%	
△ R728L,R	0110626	Metal (fuse resistor)	270Ω ±5%	RN1/4B	R906	H129651		68kΩ ±5%	
R730L,R	0119123	Metal	0.22kΩ ±10%	RN2B	R907	H129653		82kΩ ±5%	
R731L,R	0119123	Metal	0.22kΩ ±10%	RN2B	R908	H129653		82kΩ ±5%	
R732L	0129602	Carbon film	1.1kΩ ±10%	SRD1/8P	△ R001	0139005	Composition	2.7MΩ ±10%	RC1/2GF
R732R	0129606)	1.6kΩ ±10%)	ICs, FETs & TRANSISTORS				
R733L	H129603		1.2kΩ ±5%						
R733R	H129607		1.8kΩ ±5%						
R734L,R	H129613		3.3kΩ ±5%						
R735L,R	H129621		6.8kΩ ±5%						
R736L,R	H129621	6.8kΩ ±5%	SRD1/8P	for TUNER PRINTED WIRING BOARD					
R737L,R	0114041	10Ω ±5%	SRD1/4P	IC201	2367281	HA11211			
R738L,R	H129705	1.5MΩ ±5%	SRD1/8P	IC351	2367901	LB1416			
R739L,R	H129663	120kΩ ±5%	SRD1/8P	IC401L,R	2367871	HA12017			
R740L,R	0119135	2.2Ω ±10%	RN2B	IC601L,R	2367871	HA12017			
R741	H129609	2.2kΩ ±5%	SRD1/8P	Q101	2328803	2SK104 (H)			
R742	H129643	33kΩ ±5%	SRD1/8P	Q102	2328653	2SC1740LN (E)			
R743	H129631	Carbon film	10kΩ ±5%	SRD1/8P	Q151	2328802	2SK104 (F)		
R744L,R	0134370	Composition	560Ω ±10%	RC1/2GF	Q152	0573491	2SC454 (B)		
R745L,R	0134370	Composition	560Ω ±10%	RC1/2GF	Q153	0573491	2SC454 (B)		
					Q201	0573486	2SC460 (B)		
					Q202	0573486	2SC460 (B)		
					Q251	2328652	2SC1740LN (S)		
					Q301L,R	2328652	2SC1740LN (S)		
					Q302L,R	2328652	2SC1740LN (S)		
					Q303	2328652	2SC1740LN (S)		
					Q307	2328652	2SC1740LN (S)		
					Q308	2329183	2SA1015 (GR)		
					Q309	2329183	2SA1015 (GR)		
					Q310	2328652	2SC1740LN (S)		
					Q807	2328635	2SD667 (C)		
					Q808	2328652	2SC1740LN (S)		
					Q809	2329183	2SA1015 (GR)		

SYMBOL No.	STOCK No.	DESCRIPTION
for MAIN AMPLIFIER PRINTED WIRING BOARD		
IC501	2368741	μPB553AC
IC502	2368751	μPD1703C-01
IC503	2367631	TC5066BP
IC504	2368801	μPD4035C or TC4035BP
IC505	2368791	μPD4028C or TC4028BP
IC506	2368761	LB1274
IC901	2367372	HA12002 (R)
Q501	2328802	2SK104 (F)
Q502	2328653	2SC1740LN (E)
Q503	2328653	2SC1740LN (E)
Q504	2328652	2SC1740LN (S)
Q505	2328652	2SC1740LN (S)
Q506	2329183	2SA1015 (GR)
Q512	2329183	2SA1015 (GR)
Q513	2329183	2SA1015 (GR) (for U.S.A. & Canada)
Q514	2329183	2SA1015 (GR) (for Asia & Latin American
Q515	2329183	2SA1015 (GR) countries, etc.)
Q516	2329183	2SA1015 (GR)
Q517	2328653	2SC1740LN (E)
Q518	2328652	2SC1740LN (S)
Q701L,R	2367654	2SC2259 (C)
Q702L,R	2328862	2SB716 (E)
Q703L,R	2328862	2SB716 (E)
Q704L,R	2328872	2SD756 (E)
Q705L,R	2327453	2SA673 (C)
Q706L,R	2327333	2SC1213 (C)
Q707L,R	2327913	2SC1775 (E)
Q708L,R	2327893	2SA872 (E)
Q709L,R	2328632	2SD667A (C)
Q710L,R	2328622	2SB647A (C)
Q711L,R	2329161	2SC2525 (X)
Q712L,R	2329171	2SA1075 (X)
Q713L,R	2329183	2SA1015 (GR)
Q714L,R	2328652	2SC1740LN (S)
Q715L,R	2327923	2SC1775A (E)
Q716	2329183	2SA1015 (GR)
Q801	2328974	2SD330AL (F)
Q802	2328635	2SD667 (C)
Q803	2328964	2SB514AL (F)
Q804	2328625	2SB647 (C)
Q805	2328652	2SC1740LN (S)
Q806	2328974	2SD330AL (F)

DIODES

for TUNER PRINTED WIRING BOARD		
D101	2337601	1S2473
D102	2337601	1S2473
D103	2337932	1K60R
D104	2337932	1K60R
D151	2338541	KV1226
D201	2337601	1S2473
D202	2337601	1S2473
D251	2337601	1S2473
D252	2337922	1K34A

SYMBOL No.	STOCK No.	DESCRIPTION
D253	2337922	1K34A
D301	2337011	1S2076
D302	2337601	1S2473
?	?	?
D310	2337601	1S2473
D401	2337601	1S2473
D402	2337601	1S2473
D403	2337812	LED GL-5NG6 (Green)
?	?	?
D408	2337812	LED GL-5NG6 (Green)
D409	2337601	1S2473
D812	2337601	1S2473
?	?	?
D814	2337601	1S2473
ZD201	2337529	HZ-9C-3
ZD301	2337545	HZ-7B-2
ZD807	2337541	HZ-7A-1
for MAIN AMPLIFIER PRINTED WIRING BOARD		
D502	2337601	1S2473
D503	2337601	1S2473
D504	2337601	1S2473 (for U.S.A., Canada, Asia & Latin
D505	2337601	1S2473 American countries, etc.)
D506	2337601	1S2473 (except U.S.A. & Canada)
D512	2337601	1S2473 (except U.S.A. & Canada)
D551	2337502	LED SLR-30GGH (Green)
?	?	?
D556	2337502	LED SLR-30GGH (Green)
D557	2337411	LED SLR-30AR (Red)
D558	2337731	LED TLR-205 (Red)
D559	2338531	LED ARRAY (Green)
D560	2337601	1S2473
?	?	?
D562	2337601	1S2473
D563	2337601	1S2473
?	?	?
D566	2337601	1S2473
D701	2337601	1S2473
D704L,R	2337601	1S2473
D706L,R	2337641	1SS81
D707L,R	2337601	1S2473
D708L,R	2337151	1S2076A
D709L,R	2337601	1S2473
D801	2337341	S5VB-20
D802	2337761	ERB12-01R
?	?	?
D804	2337761	ERB12-01R
D901	2337151	1S2076A
ZD501	2337519	HZ-6C-3
ZD701	2337564	HZ-12-B1

SYMBOL No.	STOCK No.	DESCRIPTION	SYMBOL No.	STOCK No.	DESCRIPTION
ZD702	2337564	HZ-12-B1	L701L,R	2227361	Audio trap coil-0.67μH
ZD801	2337185	HZ-24-3	for DIAL MECHANISM ASSEMBLY		
ZD802	2338653	RD27EB3	Δ T001	2219681	Power transformer
ZD803	2337185	HZ-24-3	MISCELLANEOUS		
ZD804	2337185	HZ-24-3	CT151	0283124	Trimmer capacitor
ZD805	2337515	HZ-6B-2	MF201	2134992	FM ceramic filter
ZD806	2337531	HZ-15-1	}	}	} (for U.S.A. & Canada)
VA701L,R	2347041	Varistor MV-5	MF203	2134992	
VA702L,R	2347041	Varistor MV-5	FM201	2135002	FM ceramic filter
TH701L,R	2347113	Thermistor 112102-2	}	}	} (except U.S.A. & Canada)
TH702L,R	2347114	Thermistor 112103-2	MF203	2135002	
TH703L,R	2347114	Thermistor 112103-2	MF251	2154481	AM ceramic filter
for DIAL MECHANISM ASSEMBLY			CP201	2134931	Anti-birdy filter
D001	2337411	LED SLR-30 AR (Red)	CP301L,R	2134842	Leak filter
VARIABLE RESISTORS			CP501	0189021	CR multiple component
for TUNER PRINTED WIRING BOARD			CP502	0189014	CR multiple component
R222	0151334	50kΩ-(B) (for mute width adj.) (except U.S.A. & Canada)	CP503	0241891	CR multiple component
R303	0151336	300kΩ-(B) (for separation adj.)	CP504	0189031	CR multiple component
R603L,R	0156156	200kΩ-(B) (VOLUME)	CP505	0189014	CR multiple component
R615L,R	0151874	50kΩ-(C) (TREBLE)	Δ CP001	0269019	Spark killer (for U.S.A. & Canada)
R620L,R	0151874	50kΩ-(C) (BASS)	S301,407	2639321	6 keys push switch (TONE, SUBONIC FIL. others)
R623L,R	0151875	50kΩ-(HB) (BLANCE)	502,		
			601-603		
			S401-404	2639322	4 keys push switch (AM, FM, PHONO, AUX)
for MAIN PRINTED WIRING BOARD			S405,406	2639323	2 keys push switch (TAPE-1, TAPE-2)
R711L,R	0151334	50kΩ-(B) (for DC output adj.)	S501	2627461	Slide switch (SPACING) (for U.S.A., Canada, Asia & Latin American countries, etc.)
R726L,R	0151338	200Ω-(B) (for idle adj.)	S551	2638242	Tact switch (AM-FM PRESET, others)
R729L,R	0151338	200Ω-(B) (for idle adj.)	S559	2638242	Tact switch
COILS & TRANSFORMERS			S701,702	2638623	2 keys push switch (SPEAKERS)
for TUNER PRINTED WIRING BOARD			Δ S001	2638222	Power switch (for U.S.A. & Canada)
L101	2227354	Choke coil- 2.2μH	Δ S001	2638221	Power switch (except U.S.A. & Canada)
L151	2227353	Choke coil-100μH	RY901	2647221	Power relay
L152	2227353	Choke coil-100μH		2677392	4P US pin jack
L201	2227351	Choke coil-1μH		2657702	Jumper socket (4P)
T151	2135062	AM RF coil		2657704	Jumper socket (6P)
T152	2135041	AM OSC coil	X501	2657708	Jumper socket (10P)
T153	2154491	AM IF coil		2687852	4P screw terminal
T201	2135101	FM discriminating coil		2677581	1P US pin jack
T251	2154122	AM detect. coil		2425161	FM tuner pack
for MAIN PRINTED WIRING BOARD			J001	2787941	Crystal oscillator
L501	2227356	Choke coil-10μH		2787821	Fluorescent display tube
L502	2227353	Choke coil-100μH		4744831	Spacer
L503	2227393	Choke coil-100μH		3932781	LED holder
				2688051	Speaker screw terminal
				2677591	Headphone jack
				2667565	8P cord with housing
				4567451	3φ × 6 DT bind screw (Silver)
				4567412	3φ × 8 DT bind screw (Yellow)
				4567413	3φ × 10 DT bind screw (Yellow)
for FINAL ASSEMBLY				4412992	Cover (for U.S.A. & Canada)
				4409957	Cover (except U.S.A. & Canada)
				4575461	4φ × 8 DT screw with washer (for U.S.A. & Canada)

SYMBOL No.	STOCK No.	DESCRIPTION	SYMBOL No.	STOCK No.	DESCRIPTION						
	4575971	4 φ × 8 DT screw with washer (except U.S.A. & Canada)									
	4575952	3 φ × 8 DT screw with washer (for sw. holder fixing)									
	4407125	Fiber washer (for BASS, TREBLE, BALANCE)									
	3289351	Knob (VOLUME) ass'y									
	3286411	Knob (BASS, TREBLE, BALANCE) ass'y									
	for DIAL MECHANISM ASSEMBLY										
	3246761	Escutcheon ass'y									
	3289601	Knob-push knob (POWER)									
	3338598	Spring									
	3289602	Knob-push knob (AM, FM, PHONO, others)									
	3339598	Spring									
	3285682	Knob-push knob (SPEAKERS, TONE, others)									
	3289811	Knob-preset knob (AM-FM PRESET, others)									
	3338598	Spring									
	3932751	Hinge R (fixed) for lid									
	3932752	Hinge L (fixed) for lid									
	4576332	3 φ × 10 bind double thread screw (for hinge)									
	3246582	Lid									
	3932761	Hinge R (valiable) for lid									
	3932762	Hinge L (valiable) for lid									
	3928651	Leg									
	4412961	Back plate									
	3930862	Blind (for U.S.A. & Canada)									
	3930861	Blind (except U.S.A. & Canada)									
	2647589	LED holder									
	4567411	3 φ × 6 DT bind screw (Yellow) (for rear plate, shield case holder, other's fixing)									
	4567422	4 φ × 8 DT bind screw (for P. trans. fixing)									
	4567412	3 φ × 8 DT bind screw (for switch holder, escutcheon fixing)									
	4574603	3 φ × 10 bind double thread screw (for SPEAKERS terminal, US pin other's fixing)									
	4576332	3 φ × 10 bind double thread screw (for escutcheon, other's fixing)									
	for REAR PLATE ASSEMBLY										
	2757412	AM Loop antenna									
	3931571	Antenna holder									
	2787831	Battery box									
	4410113	Battery cover									
	2677461	Antenna socket (75 ohms) (except U.S.A. & Canada)									
	8717304	2.6 φ × 4 pan head screw (for U.S.A., Canada, Asia & Latin American countries, etc.)									
	4567431	3 φ × 6 DT bind screw (for AC outlet, Antenna socket, other's fixing)									
	for ACCESSORY										
	2748832	FM antenna									
			△	2749471	Power supply cord						
			△	2748751	Power supply cord						
			△	2749201	Power supply cord						
			△	2657471	AC outlet (2 gangs)						
			△	2618051	Voltage selector switch						
			△	0043793	Bushing (for power supply cord)						
			△	3913006	Bushing (for power supply cord)						
				2727121	Fuse holder						
				3931231	Bushing						
			△ F001	2727193	Fuse-2A						
				2657371	E socket adaptor						
			△	2727582	Fuse-4AT						
					(for ACCESSORIES)						

FRONT AND REAR PANEL · VORDERE UND HINTERE BEDIENUNGSTAEFL · PANNEAUX AVANT ET ARRIERE

- | | | |
|---|--|---|
| <ul style="list-style-type: none"> ① POWER switch ② PHONES jack ③ SPEAKERS switch ④ BASS control ⑤ TREBLE control ⑥ BALANCE control ⑦ VOLUME control ⑧ FUNCTION switches ⑨ TAPE MONITOR switches ⑩ TONE switch ⑪ SUBSONIC FILTER switch ⑫ LOUDNESS switch ⑬ FM MODE switch ⑭ FM TUNING switch ⑮ TAPE COPY switch ⑯ TUNING DOWN key ⑰ TUNING UP key ⑱ MEMORY write key ⑲ PRESET keys ⑳ POWER indicator ㉑ MEMORY write indicator | <ul style="list-style-type: none"> ㉒ Station indicators ㉓ Frequency display ㉔ FM STEREO indicator ㉕ SIGNAL indicators ㉖ FUNCTION indicators ㉗ TAPE indicators ㉘ AM loop antenna ㉙ Ground terminal (GND) ㉚ PHONO INPUT terminals ㉛ AUX INPUT terminals ㉜ AM LOOP antenna terminal ㉝ AM ANTENNA terminal ㉞ Ground terminal (GND) ㉟ FM ANTENNA terminals ㊱ FM ANTENNA terminal (75 ohms DIN) (for Europe, Asia and Latin American countries) ㊲ Channel spacing selector switch (SPACING) <ul style="list-style-type: none"> • AM 9 kHz — 10 kHz (for U.S.A. and Canada) | <ul style="list-style-type: none"> • FM 50 kHz — 200 kHz
AM 9 kHz — 10 kHz (for Asia and Latin American countries) ㊳ SPEAKERS terminal ㊴ BATTERY BOX ㊵ Power supply cord ㊶ FUSE holder (for Asia and Latin American countries) ㊷ AC outlets (for U.S.A., Canada, Asia and Latin American countries) ㊸ VOLTAGE SELECTOR (for Asia and Latin American countries) ㊹ TAPE-2 PLAY terminals ㊺ TAPE-2 REC terminals ㊻ TAPE-1 PLAY terminals ㊼ TAPE-1 REC terminals |
|---|--|---|

- | | | |
|---|--|---|
| <ul style="list-style-type: none"> ① Netzschalter (POWER) ② Kopfhörer-Buchse (PHONES) ③ Lautsprecherschalter (SPEAKERS) ④ Tiefenregler (BASS) ⑤ Höhenregler (TREBLE) ⑥ BALANCE-Regler ⑦ Lautstärkeregl. (VOLUME) ⑧ Funktionsschalter ⑨ Bandmithörschalter (TAPE MONITOR) ⑩ Klangregelschalter (TONE) ⑪ Schalter für Infraschallfilter (SUBSONIC FILTER) ⑫ Schalter für gehörrichtige Lautstärke (LOUDNESS) ⑬ UKW-Betriebsartenschalter (FM MODE) ⑭ UKW-Abstimm. (FM TUNING) ⑮ Tonband-Überspielschalter (TAPE COPY) ⑯ Abstimm. (auf niedrigere Frequenzen hin) (TUNING DOWN) ⑰ Abstimm. (auf höhere Frequenzen hin) (TUNING UP) ⑱ Speichertaste (MEMORY) ⑲ Vorprogrammierungstasten (PRESET) | <ul style="list-style-type: none"> ㉑ Netzanzeige (POWER) ㉒ Speicheranzeige (MEMORY) ㉓ Stationsanzeigen ㉔ Frequenzanzeige ㉕ UKW-Stereoanzeige (FM STEREO) ㉖ Signalanzeigen (SIGNAL) ㉗ Funktionsanzeigen ㉘ Tonbandsanzeigen (TAPE) ㉙ MW-Rahmenantenne ㉚ Erdungsklemme (GND) ㉛ PHONO-Eingangsklemmen ㉜ AUX-Eingangsklemmen ㉝ MW-Rahmenantennenbuchse (AM LOOP) ㉞ MW-Antennenklemme (AM ANTENNA) ㉟ Erdungsklemme (GND) ㊱ UKW-Antennenklemme (FM ANTENNA) ㊲ UKW-Antennenklemme (75 Ohm DIN) (FM ANTENNA) (für Europa, Asien und Südamerika) ㊳ Kanalabstandswahlschalter (SPACING) <ul style="list-style-type: none"> • AM 9 kHz — 10 kHz (für USA und Kanada) | <ul style="list-style-type: none"> • UKW 50 kHz — 200 kHz
AM 9 kHz — 10 kHz (für Asien und Südamerika) ㊴ Lautsprecher-Klemmen (SPEAKERS) ㊵ Batteriefach (BATTERY BOX) ㊶ Netzstromkabel ㊷ Halter für Sicherung (FUSE) (für Asien und Südamerika) ㊸ Wechselstromausgang (VOLTAGE SELECTOR) (für Asien und Südamerika) ㊹ Wiedergabeklemmen für Tonband-2 (TAPE-2 PLAY) ㊺ Aufnahmeklemmen für Tonband-2 (TAPE-2 REC) ㊻ Wiedergabeklemmen für Tonband-1 (TAPE-1 PLAY) ㊼ Aufnahmeklemmen für Tonband-1 (TAPE-1 REC) |
|---|--|---|

- | | | |
|--|--|---|
| <ul style="list-style-type: none"> ① Interrupteur d'alimentation (POWER) ② Prise de casque (PHONES) ③ Interrupteur d'enceintes (SPEAKERS) ④ Commande de graves (BASS) ⑤ Commande des aiguës (TREBLE) ⑥ Commande d'équilibrage (BALANCE) ⑦ Commande de VOLUME ⑧ Commutateurs de fonction ⑨ Commutateurs de contrôle de bande (TAPE MONITOR) ⑩ Commutateur de tonalité (TONE) ⑪ Commutateur de filtre infrasonique (SUBSONIC FILTER) ⑫ Commutateur de correction physiologique (LOUDNESS) ⑬ Commutateur de mode FM (FM MODE) ⑭ Commutateur d'accord FM (FM TUNING) ⑮ Commutateur de copiage de bande (TAPE COPY) ⑯ Touche d'accord descendant (TUNING DOWN) ⑰ Touche d'accord ascendant (TUNING UP) ⑱ Touche d'inscription en mémoire (MEMORY) | <ul style="list-style-type: none"> ⑲ Touches de préséglage (PRESET) ⑳ Témoin d'alimentation (POWER) ㉑ Témoin d'inscription en mémoire (MEMORY) ㉒ Témoins de station ㉓ Affichage des fréquences ㉔ Témoin FM STEREO ㉕ Témoins de SIGNAL ㉖ Témoins de fonction ㉗ Témoins de bande (TAPE) ㉘ Antenne-cadre AM ㉙ Prise de terre (GND) ㉚ Bornes d'entrée phono (PHONO INPUT) ㉛ Bornes d'entrée auxiliaire (AUX INPUT) ㉜ Bornes d'antenne-cadre AM (AM LOOP) ㉝ Borne d'antenne AM (AM ANTENNA) ㉞ Borne de terre (GND) ㉟ Bornes d'antenne FM (FM ANTENNA) ㊱ Prise d'antenne FM (75 ohms DIN) (FM ANTENNA) (pour pays d'Europe, d'Asie et d'Amérique latine) | <ul style="list-style-type: none"> ㊲ Sélecteur de palier des canaux (SPACING) <ul style="list-style-type: none"> • AM 9 kHz — 10 kHz (pour USA et Canada) • FM 50 kHz — 200 kHz
AM 9 kHz — 10 kHz (pour pays d'Asie et d'Amérique latine) ㊳ Bornes d'enceintes (SPEAKERS) ㊴ Logement des piles (BATTERY BOX) ㊵ Cordon d'alimentation ㊶ Support de fusible (FUSE) (pour l'Asie et l'Amérique latine) ㊷ Sortie C.A. (pour les E.U., le Canada l'Asie et l'Amérique latine) ㊸ Sélecteur de tension (VOLTAGE SELECTOR) (pour l'Asie et l'Amérique latine) ㊹ Bornes TAPE-2 PLAY ㊺ Bornes TAPE-2 REC ㊻ Bornes TAPE-1 PLAY ㊼ Bornes TAPE-1 REC |
|--|--|---|

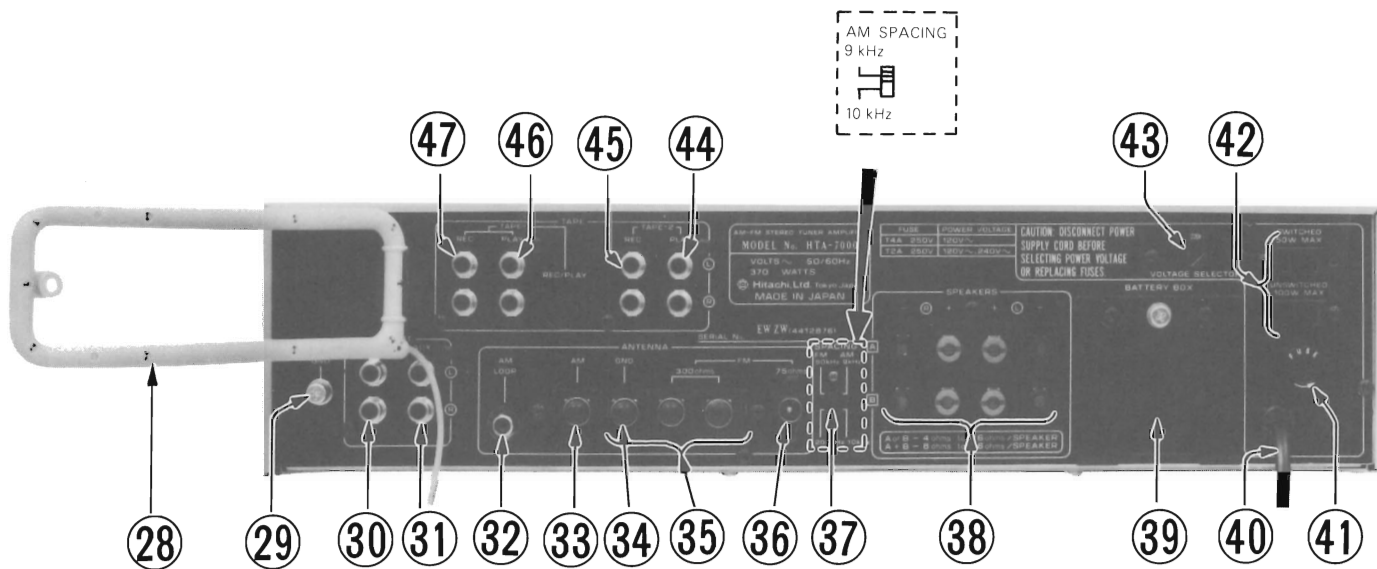
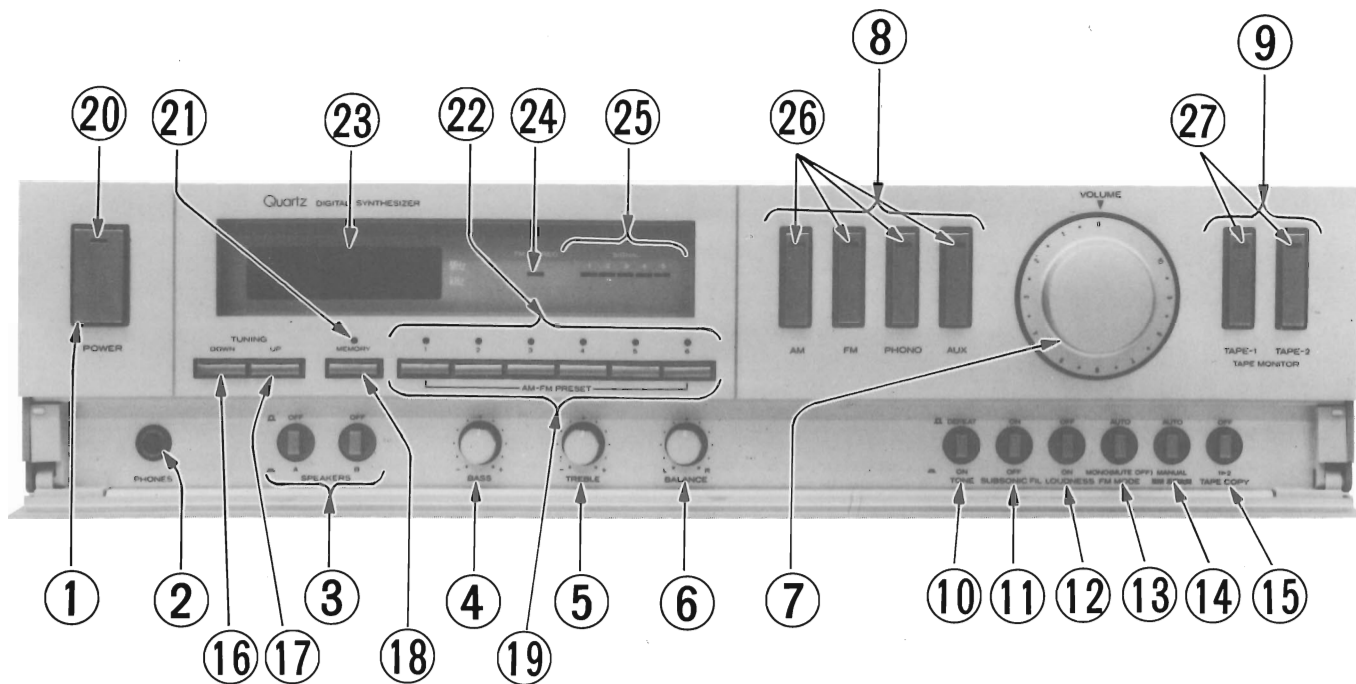



Head Office : 5-1, 1-chome, Marunouchi, Chiyoda-ku, Tokyo, Japan
Tel. : Tokyo (212) 1111 (80 lines)
Cable Address : "HITACHY" TOKYO