

HITACHI

SM0103



**SERVICE MANUAL
MANUEL D'ENTRETIEN
WARTUNGSHANDBUCH**

HTADD3E
HTADD3EBS
HTADD3W
HTADD3WUN
HTADD3WAU

CAUTION:

Before servicing this chassis, it is important that the service technician read the "Safety Precautions" and "Product Safety Notices" in this service manual.

ATTENTION:

Avant d'effectuer l'entretien du châssis, le technicien doit lire les «Précautions de sécurité» et les «Notices de sécurité du produit» présentés dans le présent manuel.

VORSICHT:

Vor Öffnen des Gehäuses hat der Service-Ingenieur die „Sicherheitshinweise“ und „Hinweise zur Produktsicherheit“ in diesem Wartungshandbuch zu lesen.

Data contained within this Service manual is subject to alteration for improvement.

Les données fournies dans le présent manuel d'entretien peuvent faire l'objet de modifications en vue de perfectionner le produit.

Die in diesem Wartungshandbuch enthaltenen Spezifikationen können sich zwecks Verbesserungen ändern.



CONTENTS

SPECIFICATIONS.....	3
SERVICE POINTS.....	4
ADJUSTMENT.....	8
WIRING DIAGRAM.....	9
PRINTED WIRING BOARD.....	10
BLOCK DIAGRAM.....	23
SCHEMATIC DIAGRAM.....	25
EXPLODED VIEW.....	43
REPLACEMENT PARTS LIST.....	47

SPECIFICATIONS AND PARTS ARE SUBJECT TO CHANGE FOR IMPROVEMENT

AV SURROUND SYSTEM
September 2000

ENGLISH

SAFETY PRECAUTIONS

WARNING: The following precautions must be observed.

ALL PRODUCTS

Before any service is performed on the chassis an isolation transformer should be inserted between the power line and the product.

1. When replacing the chassis in the cabinet, ensure all the protective devices are put back in place.
2. When service is required, observe the original lead dressing. Extra precaution should be taken to ensure correct lead dressing in any high voltage circuitry area.
3. Many electrical and mechanical parts in HITACHI products have special safety related characteristics. These characteristics are often not evident from visual inspection, nor can the protection afforded by them necessarily be obtained by using replacement components rated for higher voltage, wattage, etc. Replacement parts which have these special safety characteristics are identified by marking with a  on the schematics and the replacement parts list.
The use of a substitute replacement component that does not have the same safety characteristics as the HITACHI recommended replacement one, shown in the parts list, may create electrical shock, fire, X-radiation, or other hazards.
4. Always replace original spacers and maintain lead lengths. Furthermore, where a short circuit has occurred, replace those components that indicate evidence of overheating.
5. Insulation resistance should not be less than 2M ohms at 500V DC between the main poles and any accessible metal parts.
6. No flashover or breakdown should occur during the dielectric strength test, applying 3kV AC or 4.25kV DC for two seconds between the main poles and accessible metal parts.
7. Before returning a serviced product to the customer, the service technician must thoroughly test the unit to be certain that it is completely safe to operate without danger of electrical shock. The service technician must make sure that no protective device built into the instrument by the manufacturer has become defective, or inadvertently damaged during servicing.

CE MARK

1. HITACHI products may contain the CE mark on the rating plate indicating that the product contains parts that have been specifically approved to provide electromagnetic compatibility to designated levels.
2. When replacing any part in this product, please use only the correct part itemised in the parts list to ensure this standard is maintained, and take care to replace lead dressing to its original state, as this can have a bearing on the electromagnetic radiation/immunity.

PICTURE TUBE

1. The line output stage can develop voltages in excess of 25kV; if the E.H.T. cap is required to be removed, discharge the anode to chassis via a high value resistor, prior to its removal from the picture tube.
2. High voltage should always be kept at the rated value of the chassis and no higher. Operating at higher voltages may cause a failure of the picture tube or high voltage supply, and also, under certain circumstances could produce X-radiation levels moderately in excess of design levels. The high voltage must not, under any circumstances, exceed 29kV on the chassis (except for projection Televisions).
3. The primary source of X-radiation in the product is the picture tube. The picture tube utilised for the above mentioned function in this chassis is specially constructed to limit X-radiation. For continued X-radiation protection, replace tube with the same type as the original HITACHI approved type
4. Keep the picture tube away from the body while handling. Do not install, remove, or handle the picture tube in any manner unless shatterproof goggles are worn. People not so equipped should be kept away while picture tubes are handled

LASERS

If the product contains a laser avoid direct exposure to the beam when the cover is open or when interlocks are defeated or have failed.

Check that exposed parts are acceptably insulated from the supply circuit before returning the repaired instrument to the customer.

- Checking method

Measure the resistance value between the both poles of attachment cup (Power supply plug) and the exposed parts (Parts such as Knob, Cover, etc. where the customer is easy to touch.) and check that the resistance value is 500 kohms or more.

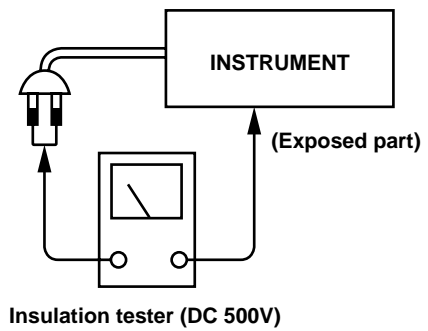

SAFETY PRECAUTIONS

The following precautions should be observed when servicing.

1. Since many parts in the unit have special safety-related characteristics, always use genuine Hitachi's replacement parts. Especially critical parts in the power circuit block should not be replaced with other makers. Critical parts are marked with _ in the circuit diagram and printed wiring board.
2. Before returning a repaired unit to the customer, the service technician must thoroughly test the unit to ascertain that it is completely safe to operate without danger of electrical shock.

SPECIFICATIONS

• AUDIO SECTION

(Power amplifier)	For (E, EBS)	For (W, WUN, WAU)
Rated output:	Front: 80 W + 80 W (6 Ω/ohms, 20 Hz ~ 20 kHz with 0.1 % T.H.D.) Centre: 80 W (6 Ω/ohms, 20 Hz ~ 20 kHz with 0.1 % T.H.D.) Surround: 80 W + 80 W (6 Ω/ohms, 20 Hz ~ 20 kHz with 0.1 % T.H.D.)	100 W + 100 W (EIAJ, 6 ohms) 100 W (EIAJ, 6 ohms) 100 W + 100 W (EIAJ, 6 ohms)
SINUS power:	Front: 90 W + 90 W (6 Ω/ohms, 1 kHz, 0.1 %) Centre: 90 W (6 Ω/ohms, 1 kHz, 0.1 %) Surround: 90 W + 90 W (6 Ω/ohms, 1 kHz, 0.1 %)	
Output terminals:	Front: A or B 6 to 16 Ω/ohms A + B 12 Ω/ohms or more Center/Surround: 6 to 16 Ω/ohms	
(Analog)		
LINE input		
Input sensitivity / input impedance:	200 mV / 47 kΩ/kohms	
Frequency response:	10 Hz ~ 50 kHz: +1, -3 dB	
S/N ratio:	93 dB (IHF-A weighted)	
Total harmonic distortion:	0.1% (20 Hz ~ 20 kHz)	
PHONO input-REC OUT		
Input sensitivity / input impedance:	2.5 mV / 47 kΩ/kohms	
RIAA deviation:	±1 dB (20 Hz ~ 20 kHz)	
S/N ratio:	74 dB (IHF-A weighted, with 5mV input)	
Total harmonic distortion:	0.03% (1 kHz, 3V)	
Rated output / Maximum output:	150 mV / 7V	

• VIDEO SECTION

(Composite)	
Input/output level and impedance:	1 Vp-p, 75 Ω/ohms
Frequency response:	5 Hz ~ 10 MHz +1, -3 dB
(S-Video)	
Input/output level and impedance:	Y=1 Vp-p, C=0.286 Vp-p
Frequency response:	5 Hz ~ 10 MHz +1, -3 dB
(Component)	
Input/output level and impedance:	Y=1 Vp-p, C _B =0.7 Vp-p, C _R =0.7 Vp-p
Frequency response:	5 Hz ~ 10 MHz +1, -3 dB

• TUNER SECTION

Receiving range:	[FM] (note: μV at 75Ω/ohms, 0 dBf = $1 \infty 10^{-15}W$) [AM] 87.50 MHz ~ 108.00 MHz (0.05 MHz step)	522 kHz ~ 1611 kHz (9 kHz step) (E, EBS) 522 kHz ~ 1611kHz (9 kHz step), 520 ~ 1710 kHz (10 kHz step) (W, WUN,WAU)
Usable sensitivity:	2.0 μV (17.2 dBf)	600 μV
50 dB quieting sensitivity:	STEREO	23μV (38.5 dBf)
S/N ratio:	MONO	80 dB (IHF-A weighted)
	STEREO	75 dB (IHF-A weighted)
Total harmonic distortion:	MONO	0.2% (1kHz)
	STEREO	0.4% (1kHz)

• GENERAL

Power supply:	AC 230V, 50 Hz (E,EBS), AC 110 ~ 127V/220 ~ 240V, 50/60 Hz (W, WUN,WAU)
Power consumption:	180 W (Standby mode = 1.5W)
Maximum external dimensions:	434 (W) ∞ 144 (H) ∞ 320 (D) mm
Weight:	8.1 kg

• REMOTE CONTROL UNIT (RB-DD1S)

Batteries:	R6P/AA Type (two batteries)
External dimensions:	54 (W) ∞ 172 (H) ∞ 27.2 (D) mm
Weight:	100 g (including batteries)

• Accessory supplied:	Operating instructions, Remote control unit (RB-DD1S), R6P/AA batteries, AM loop antenna and FM indoor antenna
-----------------------	---

* For purposes of improvement, specifications and design are subject to change without notice.

SERVICE POINTS

1. Removal of Top Cover

- (a) Remove 2 screws 1 from each side.
- (b) Remove 4 screws 2 from the rear plate.

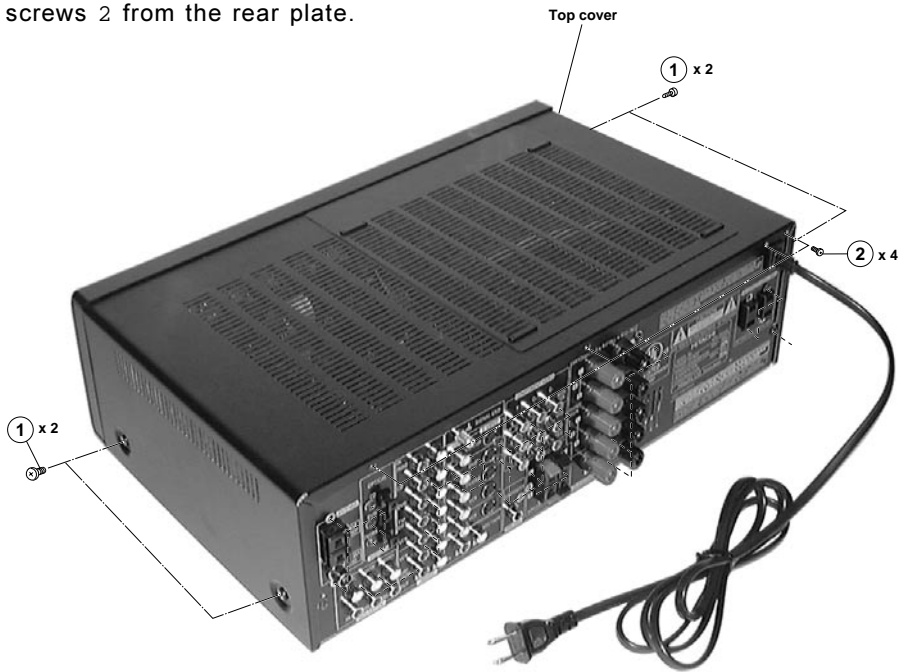

Fig. 1

2. Removal of Rear Plate

- (a) Remove 28 screws 3 and 1 screw 4 from the rear plate.
- (b) Remove 5 screws - from the Bottom Chassis.

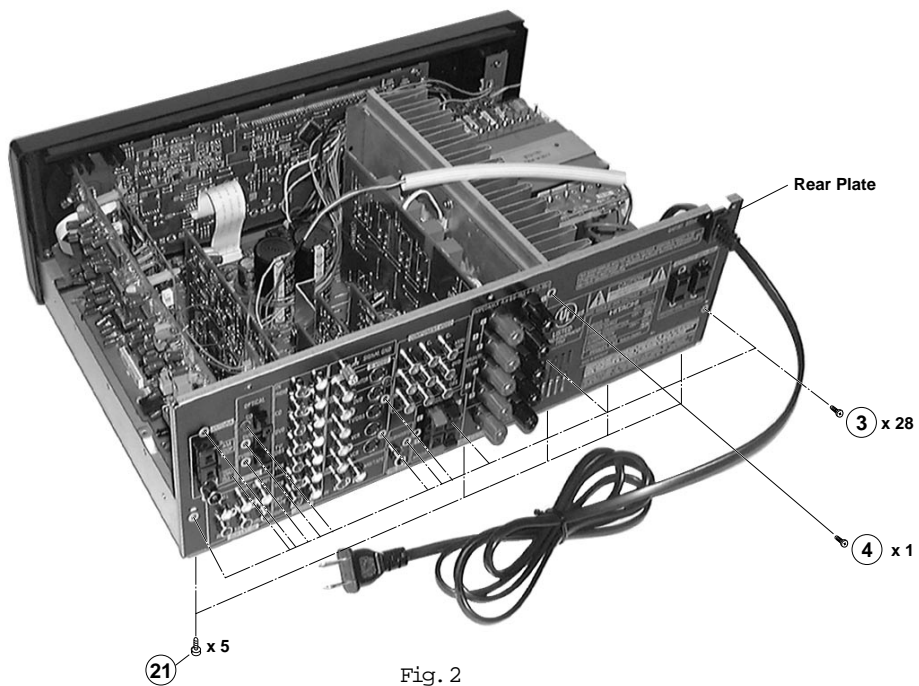

Fig. 2

3. Removal of Tuner & DSP PWB board

- (a) Remove the Push Rivet from the Holder (Front) & Holder (Back) then remove the flat cable Z at the Tuner PWB.
- (b) Remove 1 screw + to detach the shield plate from the bottom chassis.
- (c) Gently pull the Tuner & DSP PWB board upwards to detach its connectors A, B, C, D, E & F from Main PWB board.

Removal of Audio PWB board

- (a) Gently pull the Audio PWB board upwards to detach its 4 connectors H, I, J & K from Main PWB board.

Removal of S Video/Composit PWB board

- (a) Gently pull the Composit and S Video PWB board upwards to detach its 2 connectors L & M from Main PWB board.

Removal of Components PWB board

- (a) Gently pull the Components PWB board upwards to detach its connector N from Main PWB board.

Removal of Relay PWB board

- (a) Gently pull the Relay PWB board upwards to detach its 3 connectors O, P & Q from Main PWB board.

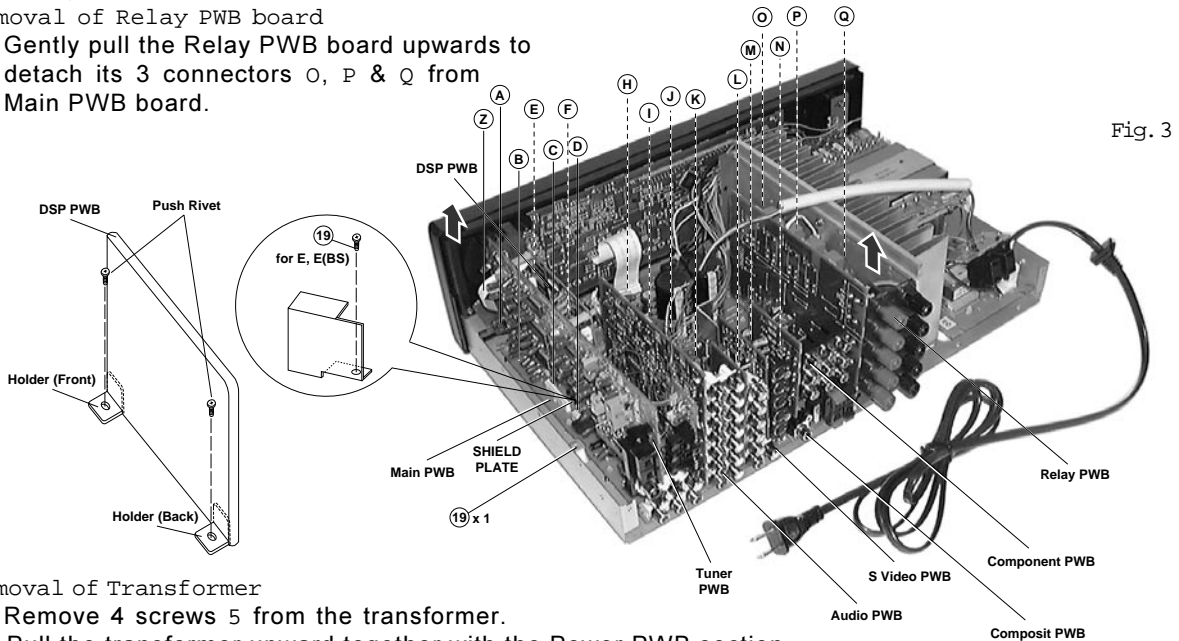

Fig. 3

4. Removal of Transformer

- (a) Remove 4 screws 5 from the transformer.
- (b) Pull the transformer upward together with the Power PWB section.

Removal of Power PWB board

- (a) Remove 1 screw 6 from the Bottom chassis at the side.
- (b) Release the Power PWB board from its 3 holding claws (PWB support) and gently pull the board free.

Removal of Main PWB board

- (a) Detach Flat Cable from FL PWB Board.
- (b) Remove 4 screws 7 to release the Power IC from the heat-sink.
- (c) Remove 3 screws , to release the bracket from the heat-sink.
- (d) Remove 1 screw 8 to release the Component from the heat-sink.

Removal of Heat-Sink

- (a) Invert the Bottom Chassis, remove 2 screws 9 connect to the heat-sink (Fig 5).

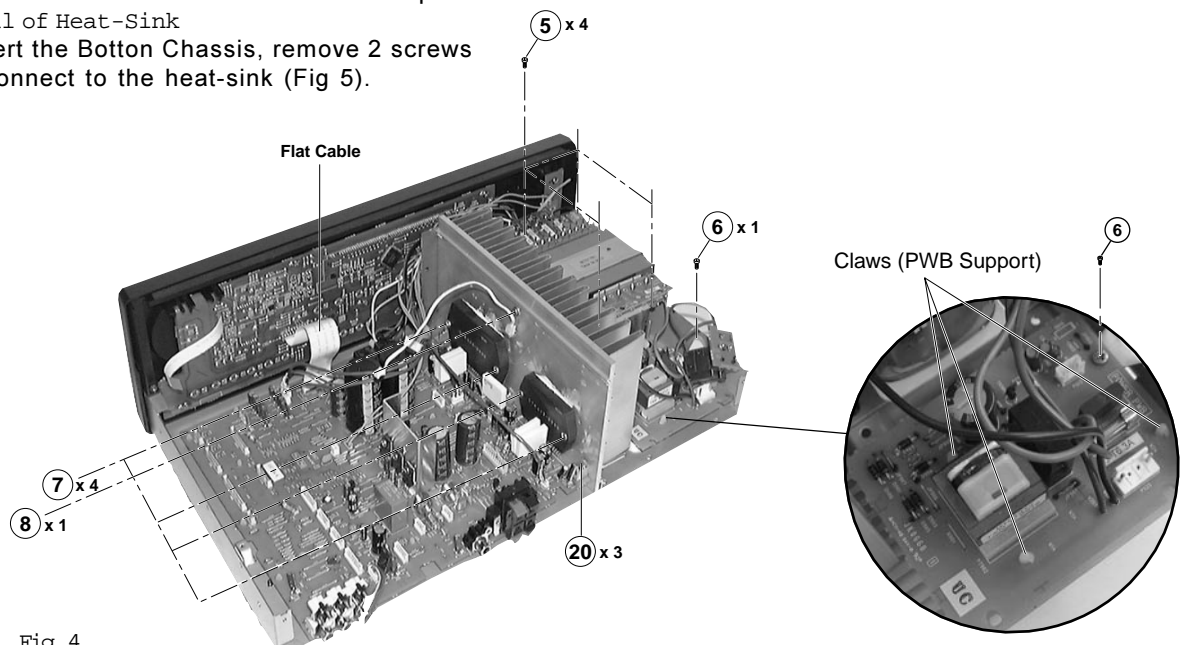

Fig. 4

5. Removal of Front Panel

- (a) Invert the Bottom Chassis and remove 4 screws !.
- (b) Remove the Master Vol. & Bass/Treble knob before remove the Front panel.

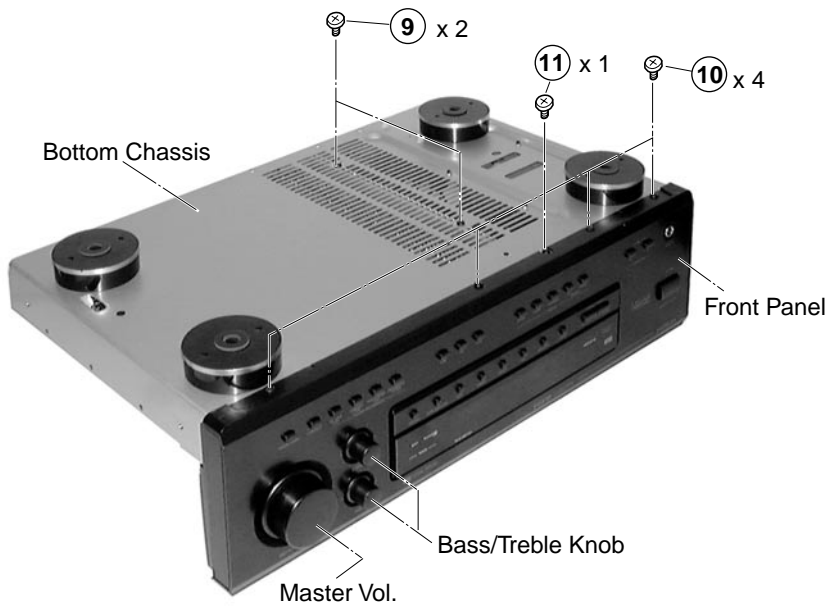

Fig. 5

6. Removal of Inner Panel, Power Switch, Phone Jack & FL board.

- (a) Release the inner panel from the bottom chassis by remove 1 screw " (Fig 5) and 2 screws #.
- (b) Remove 11 screws \$ and 3 nuts to release the FL board.
- (c) Remove 2 screws % to release the Power switch.
- (d) Remove 2 screws & to release the Phone Jack.

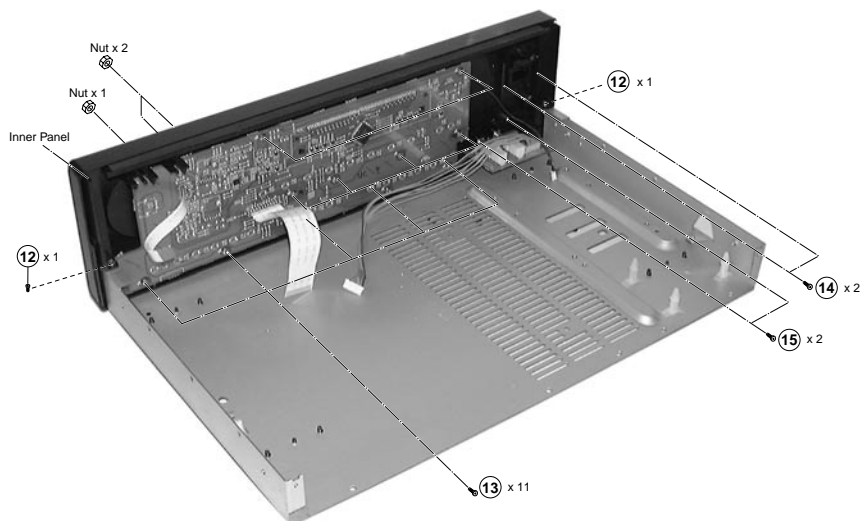

Fig. 6

7. Removal of Foot

(a) Remove 4 screws (to remove foot.

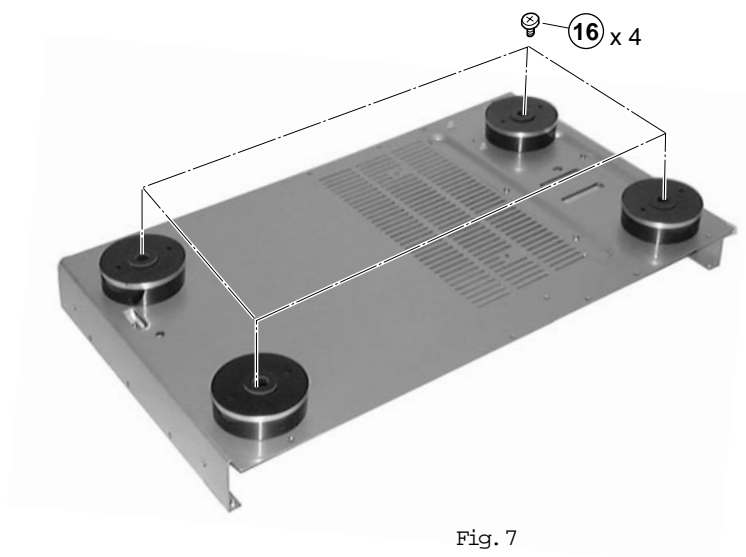

Fig. 7

ADJUSTMENTS

1) FM Discriminator

Measuring instrument and condition.

Input terminal	Output terminal	Measuring instrument	Frequency	Adjust	Reading
FM antenna 1kHz, 60dBu, 22.5kHz dev.	* R22	DC balance meter	98.1 MHz	T4	0±30mV

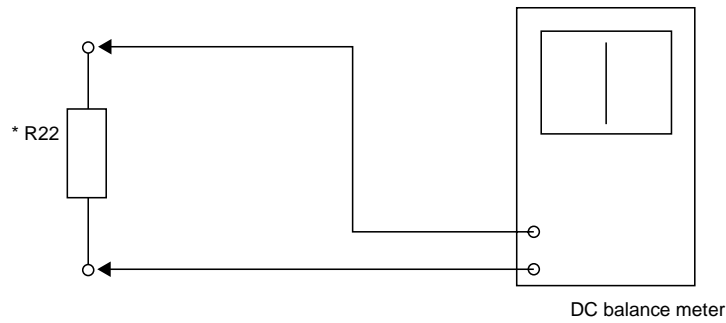

2) Voltage of covering (Reference)

Band	Destination	Frequency	Specification		Note
			Limit(V)	Average(V)	
FM	E/EBS (50kHz step)	87.50MHz	1.3-3.7	2.4	
		108.00MHz	6.0-9.0	7.5	
	W/WUN/WAU (50kHz step)	87.50MHz	1.3-3.7	2.4	
		108.00MHz	6.0-9.0	7.5	
AM	E/EBS (9kHz step)	522kHz	0.9-1.2	1.1	
		1,611kHz	6.0-9.0	7.5	
	W/WUN/WAU (9kHz step)	522kHz	0.9-1.2	1.1	
		1,611kHz	6.0-9.0	7.5	

3) Tuning level (dB) adjustment

Input – FM antenna, 1 KHz, 26 dB μ V, 75 KHz

Adjust – VR1

Limit – 26±2dB

(NOTE) Adjust VRI until "Tuned" Indicator light on.

WIRING DIAGRAM

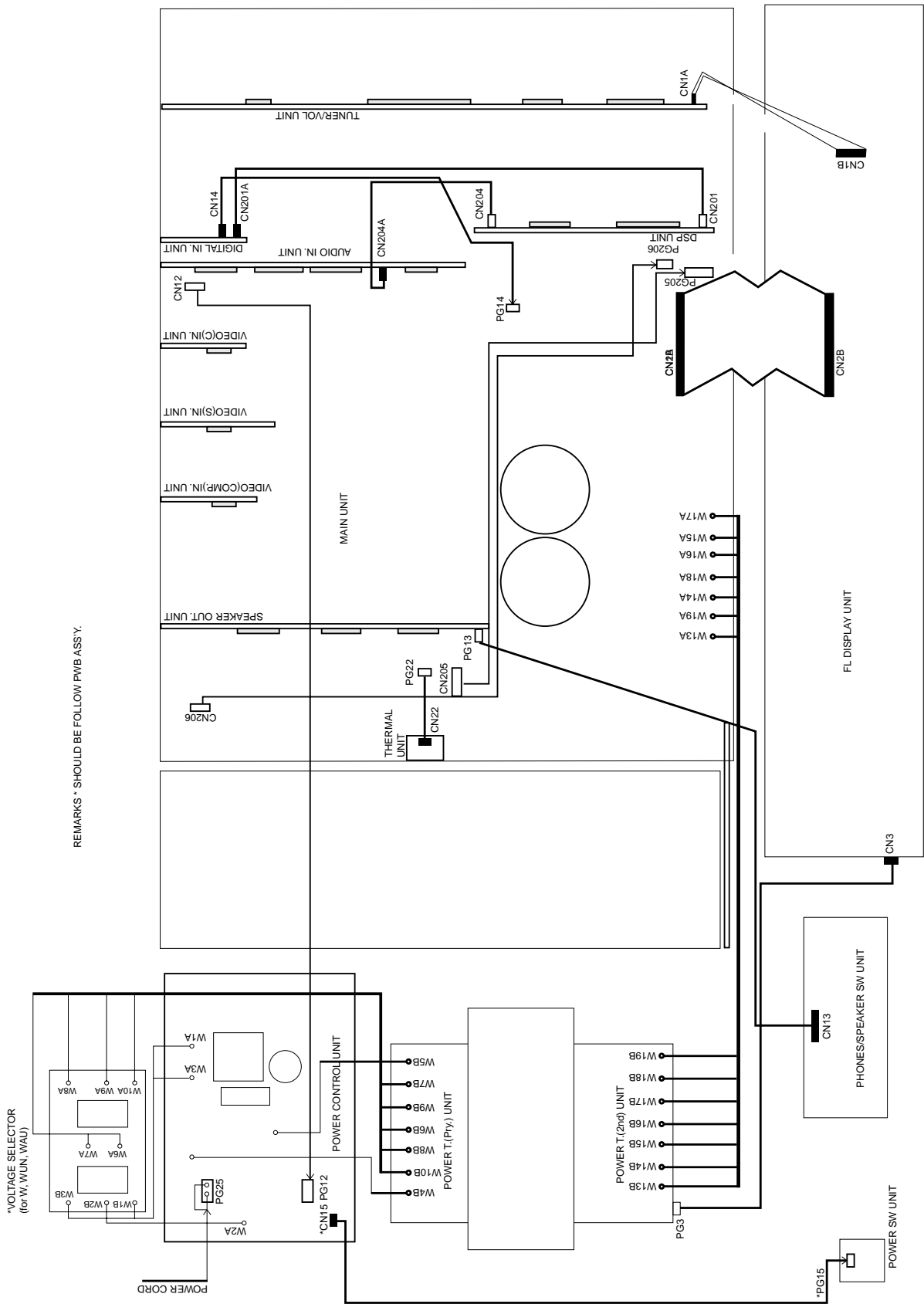

PRINTED WIRING BOARD

Soldering Side

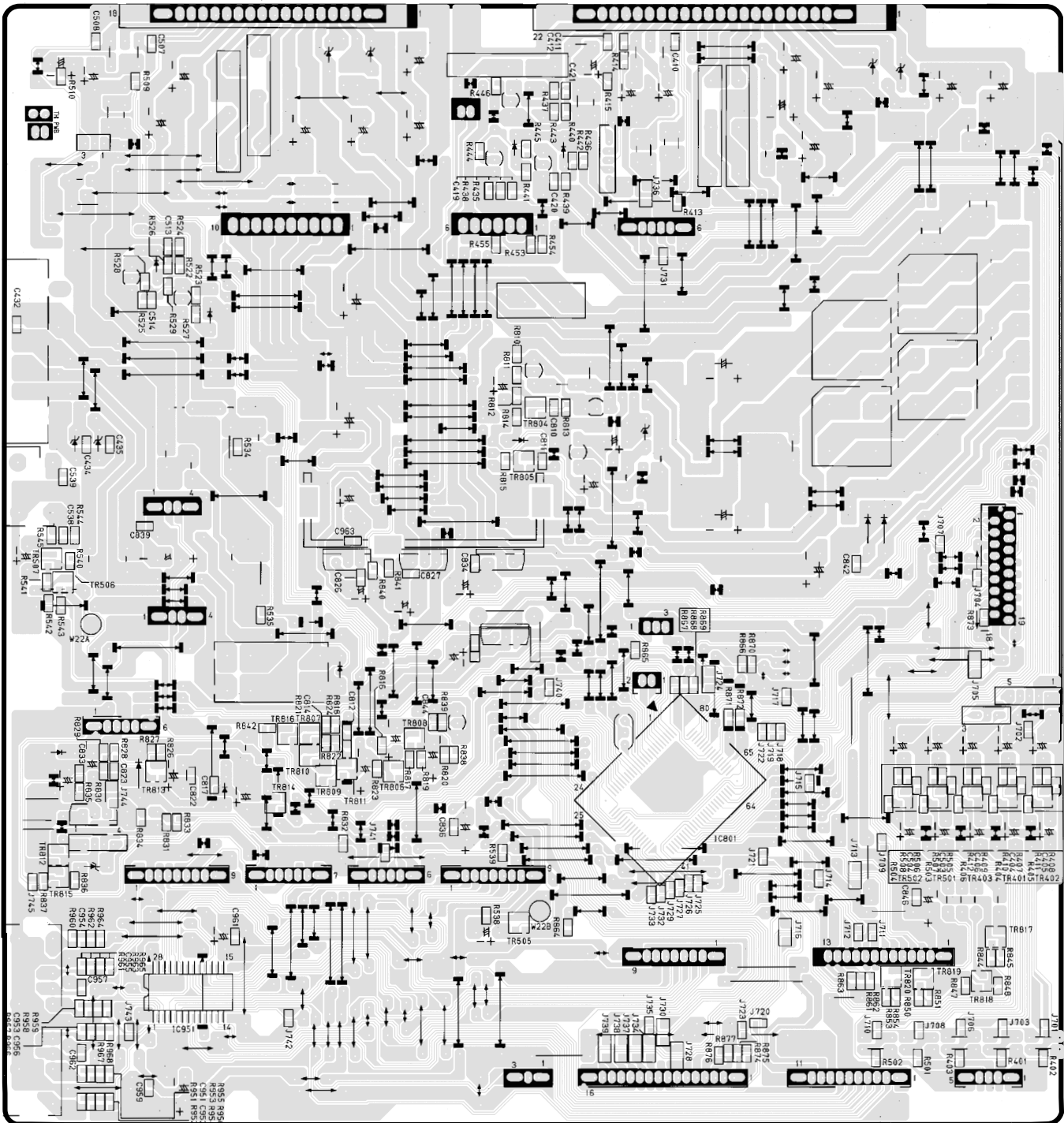

MAIN PWB

Soldering Side

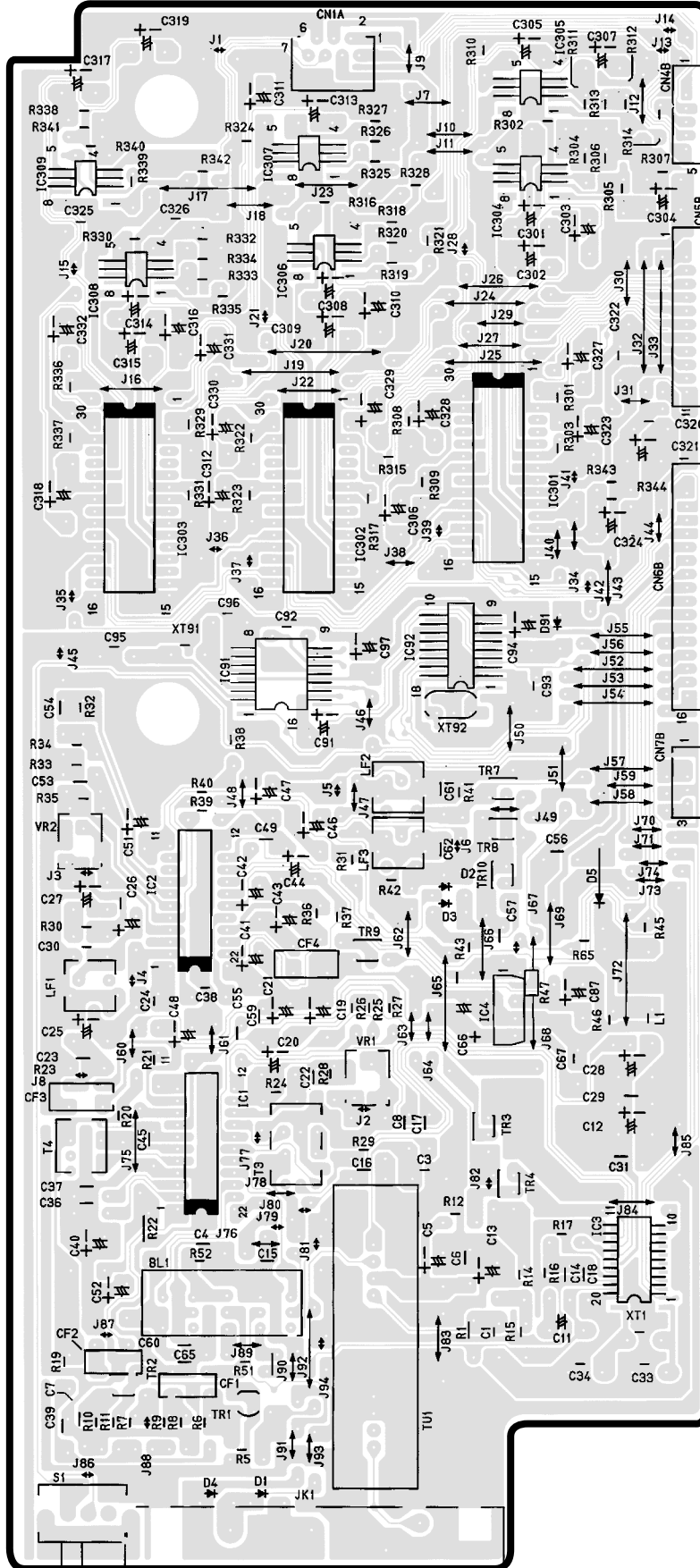

Tuner PWB

Component Side

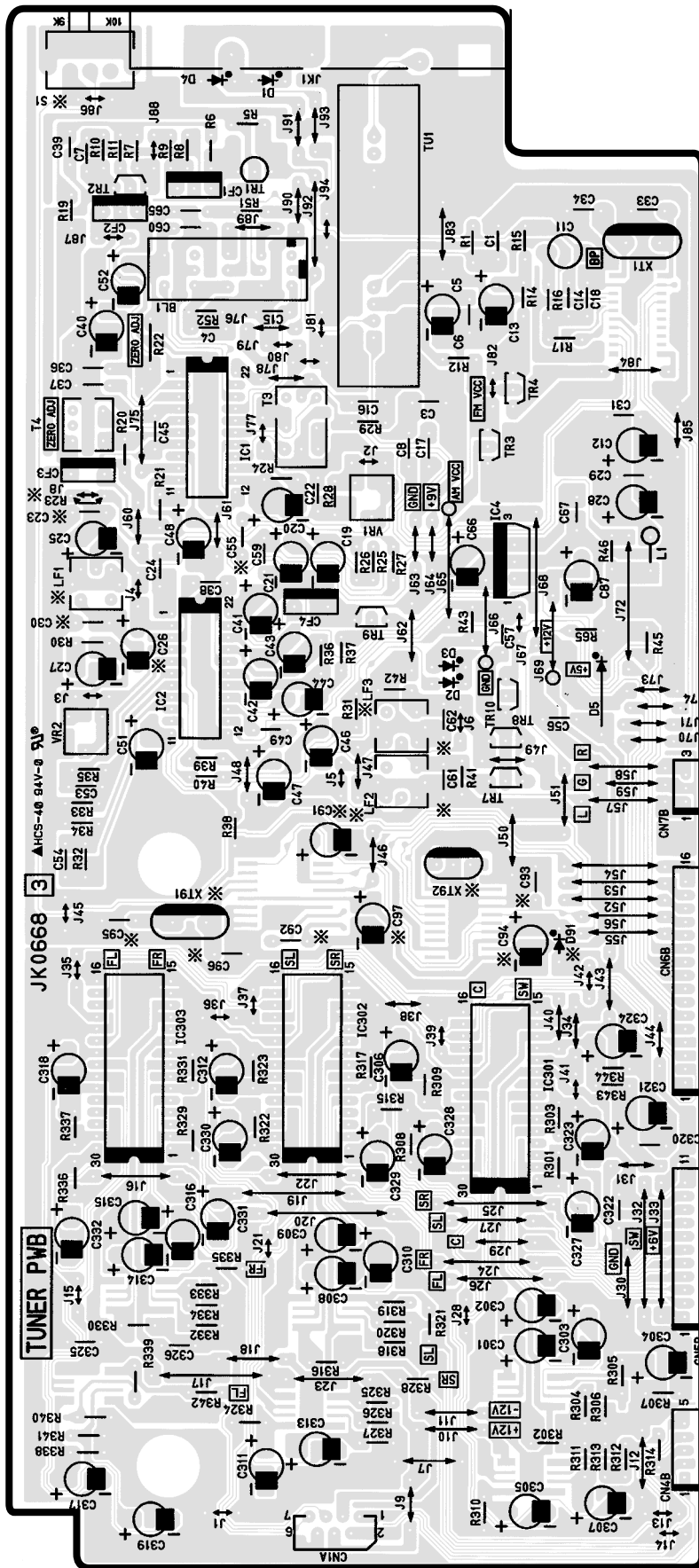

Tuner PWB

Component Side

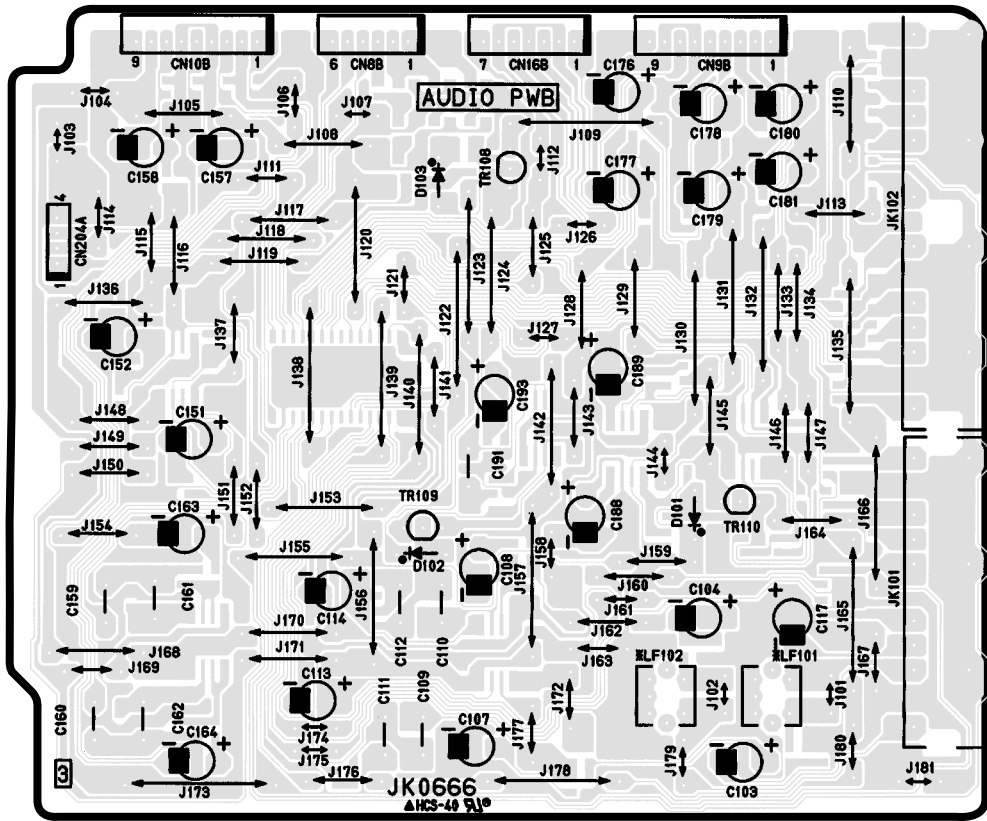

Soldering Side

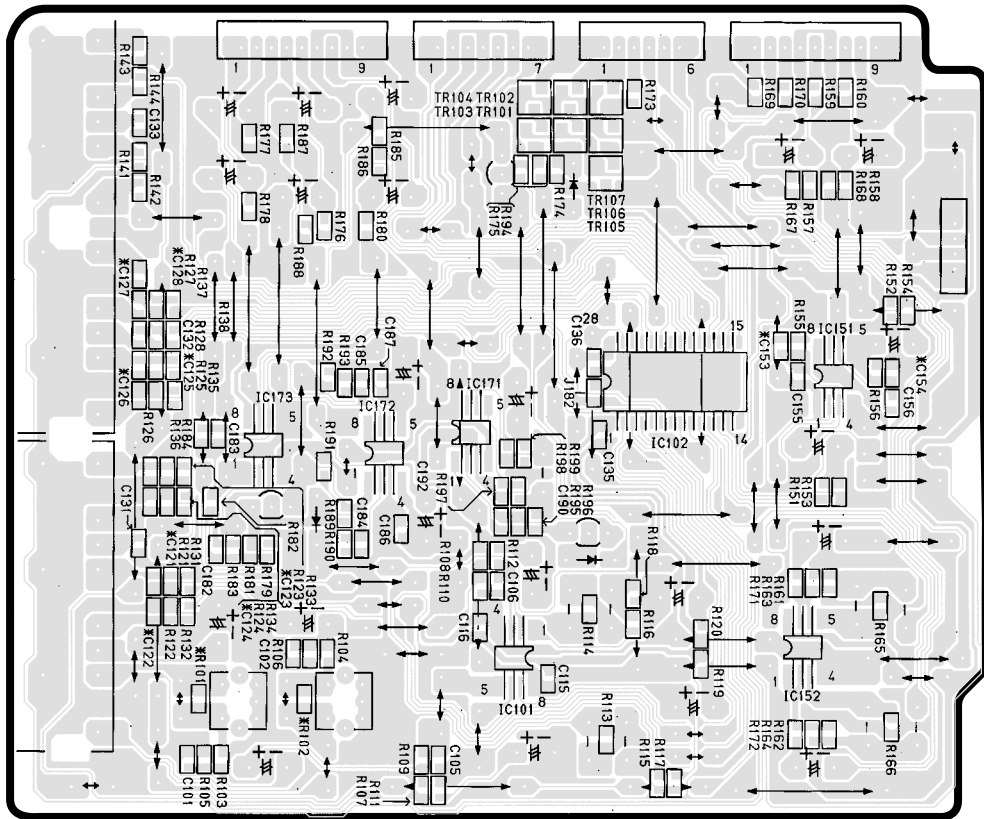

Audio PWB

Component Side

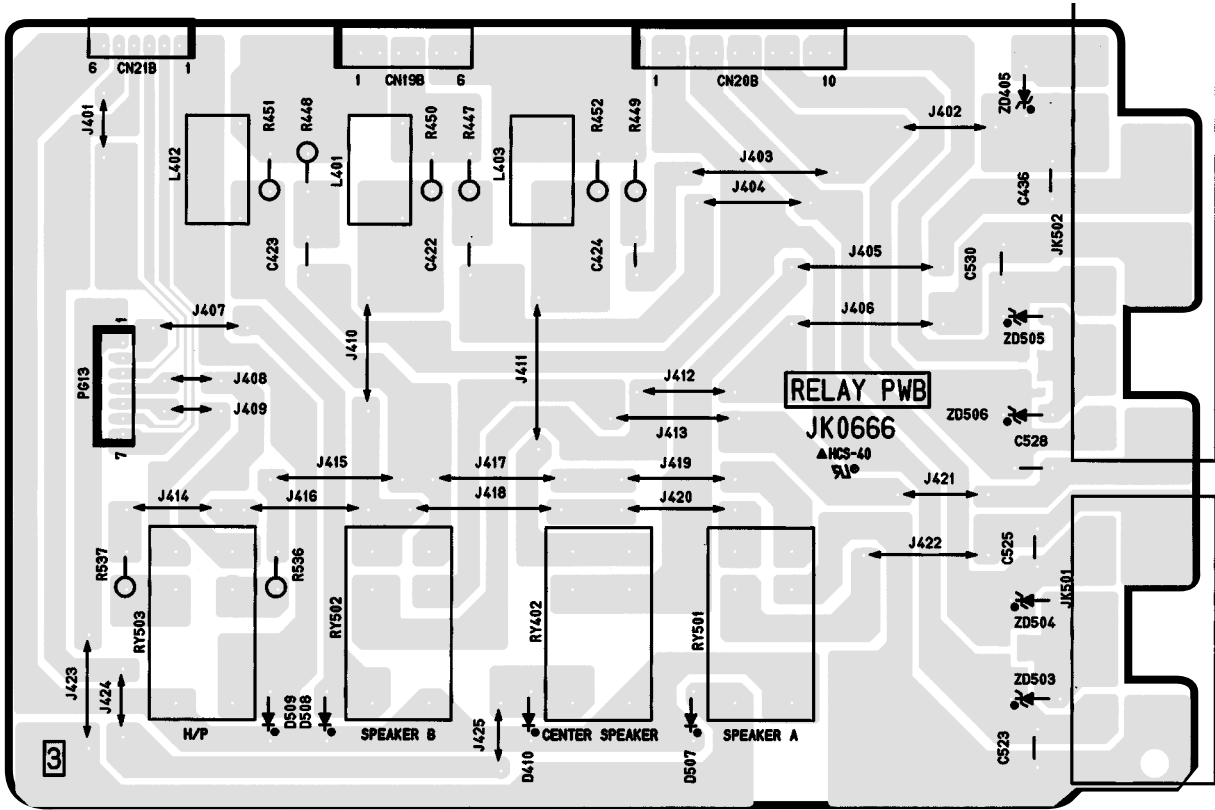

Soldering Side

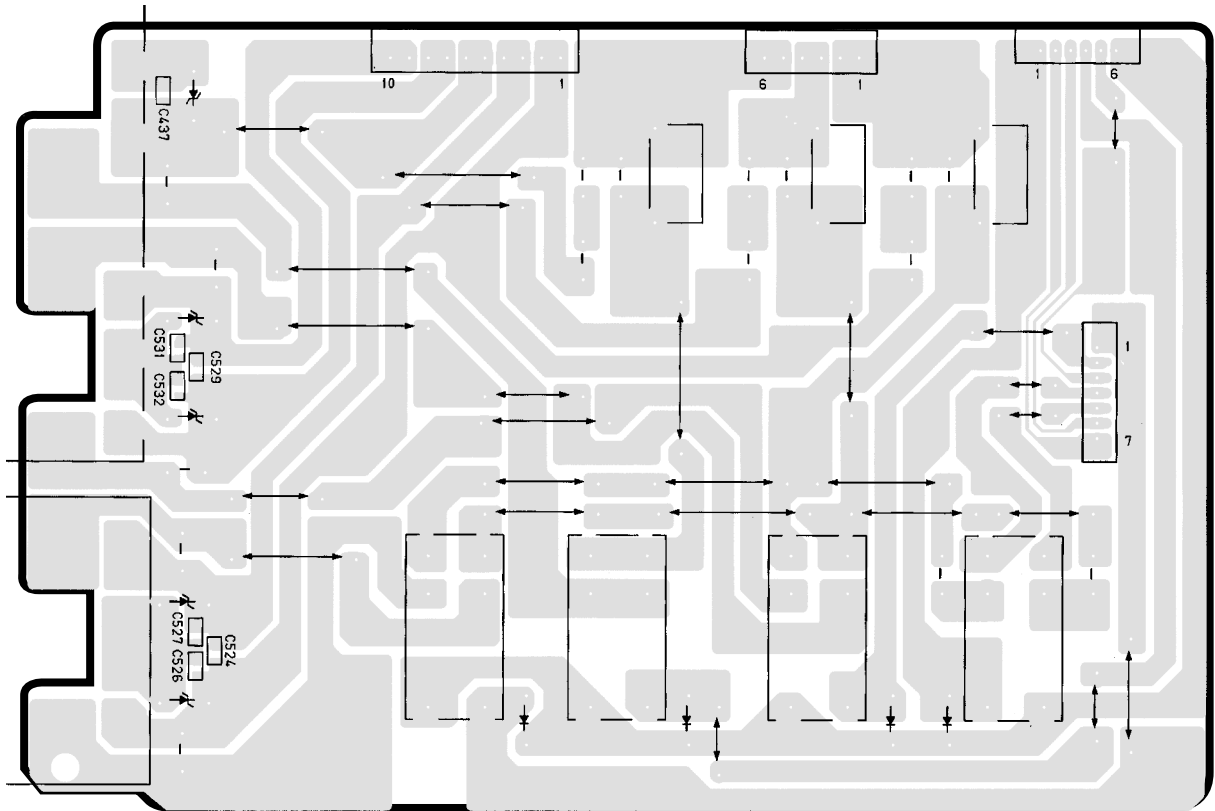

Relay PWB

Component Side

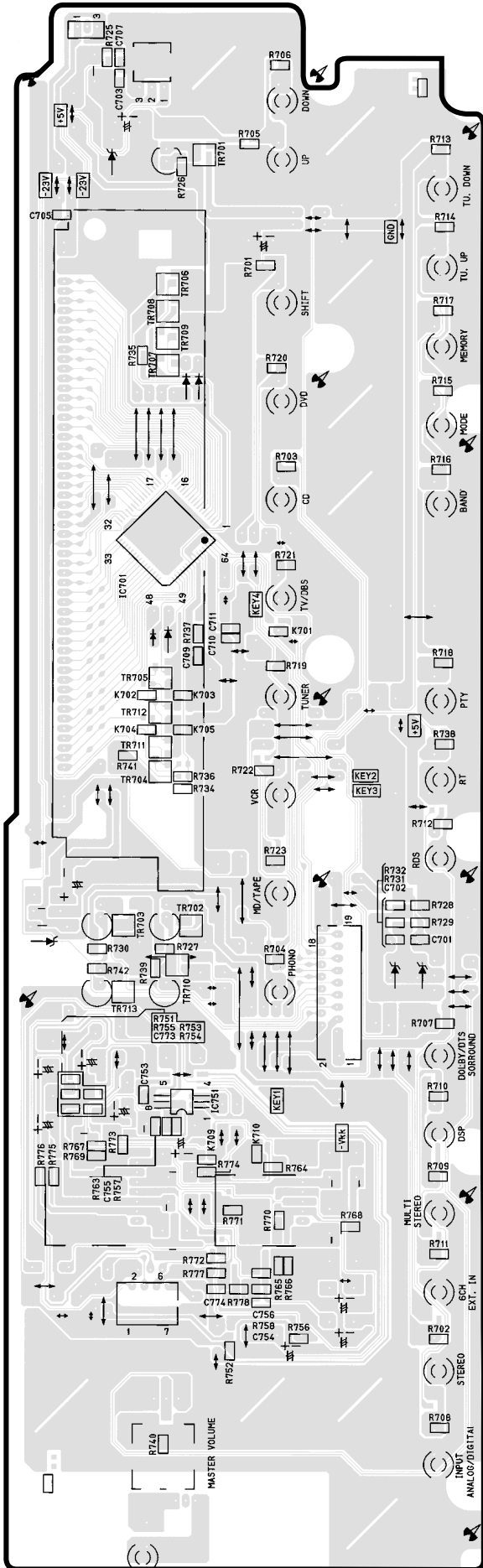

FL PWB

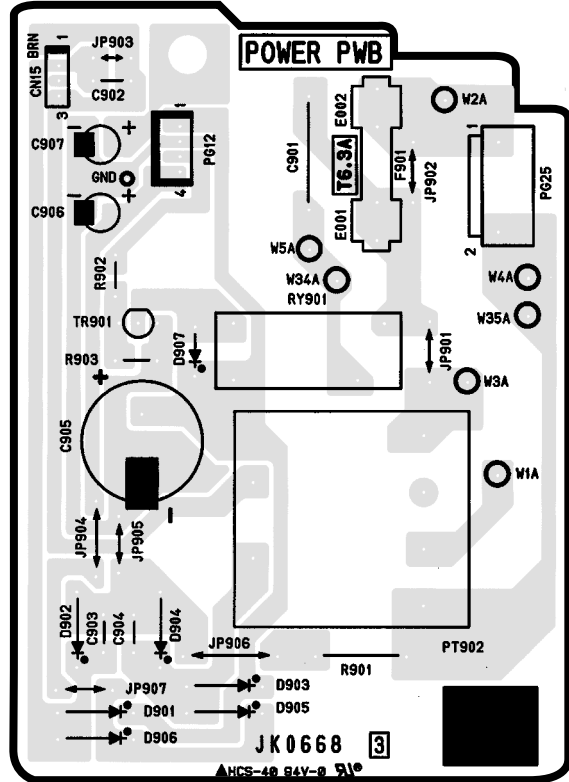

Power PWB

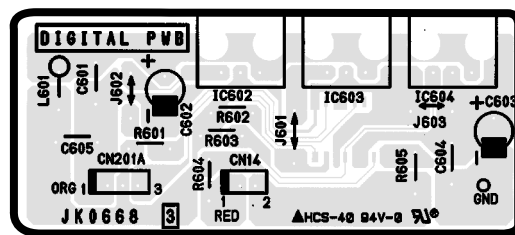

DigitalPWB

Soldering Side

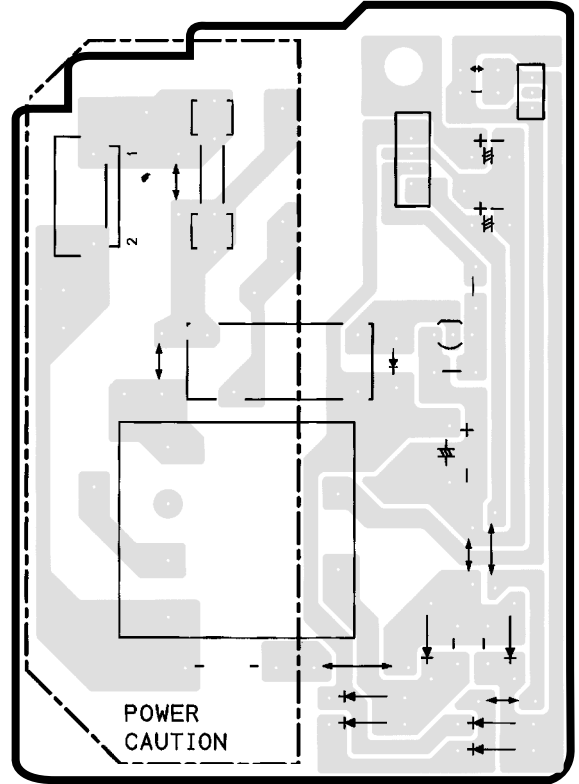
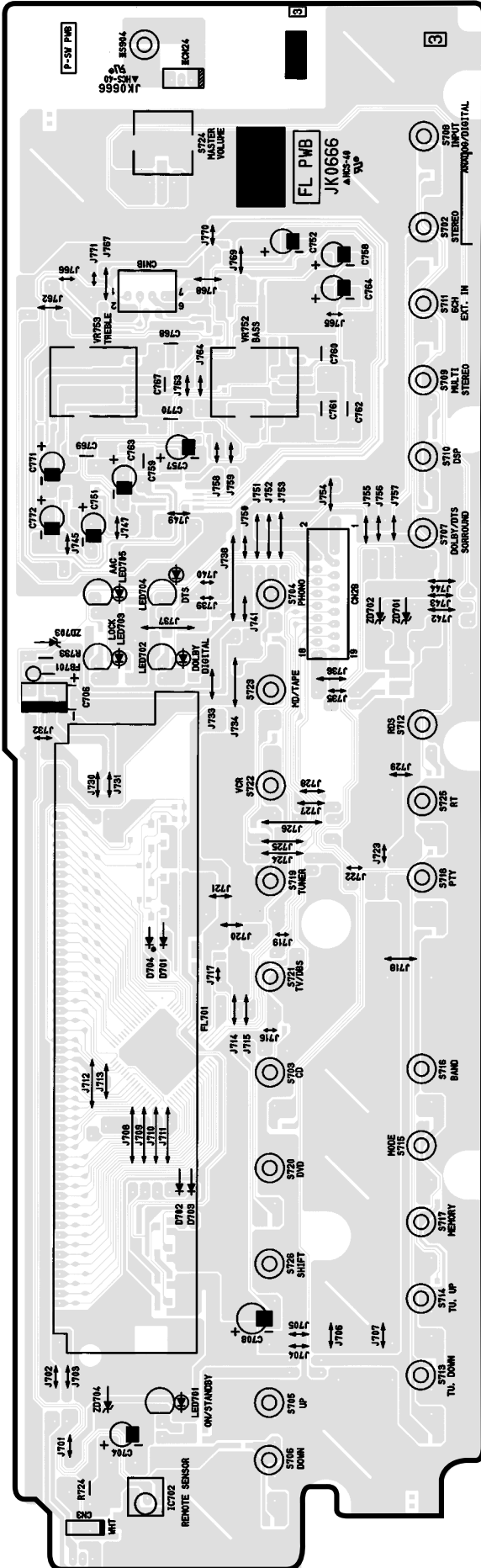

Power PWB

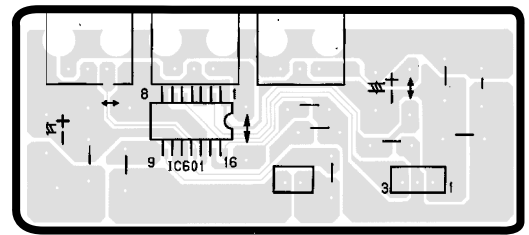

Digital PWB

Soldering Side

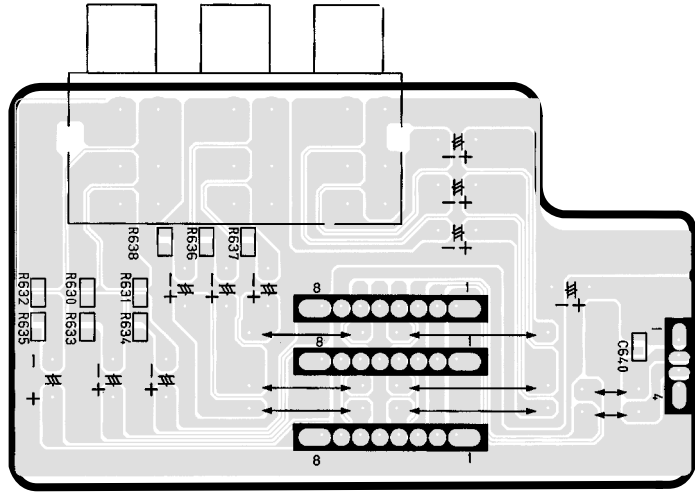

Component Side

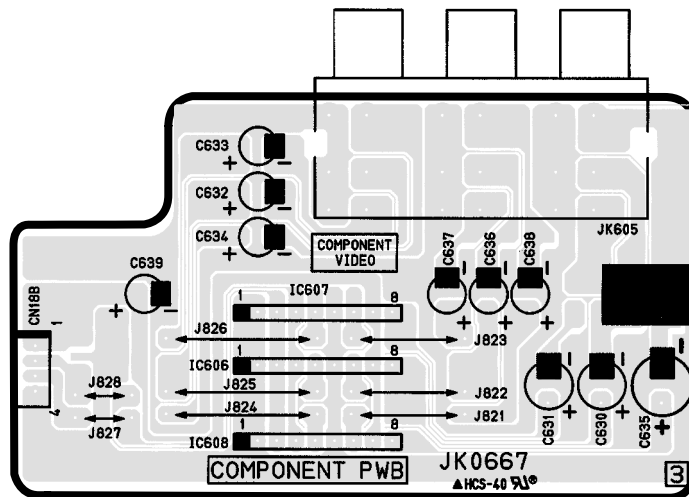

Component PWB

Soldering Side

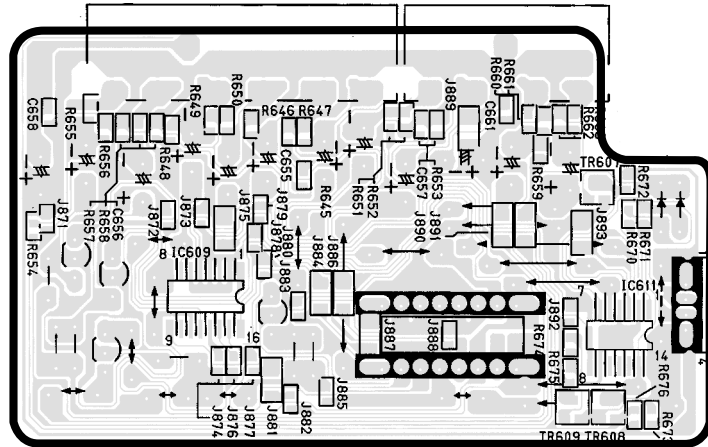

S-Video PWB

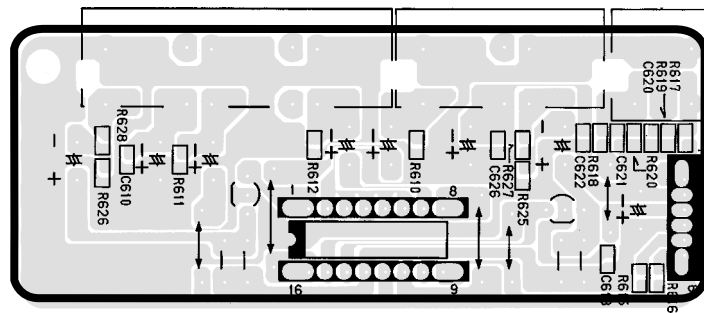

Composit PWB

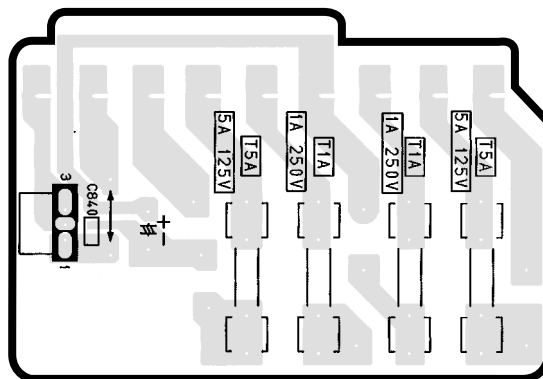

PT2 PWB

Component Side

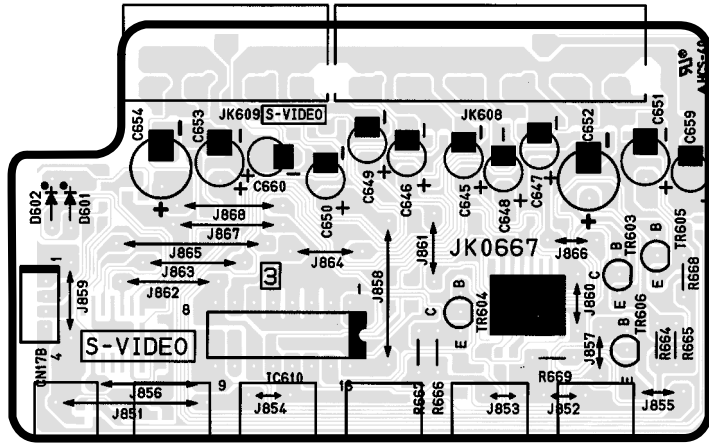

S-Video PWB

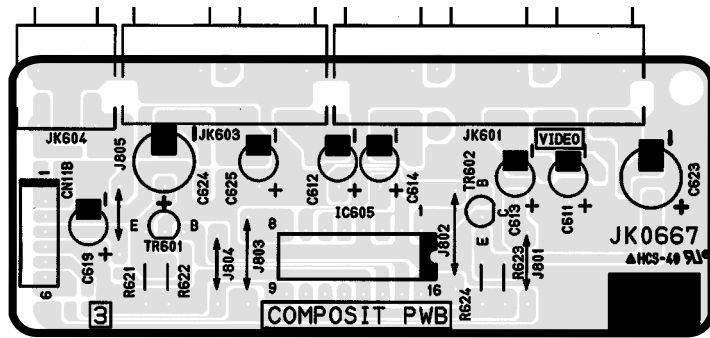

Composit PWB

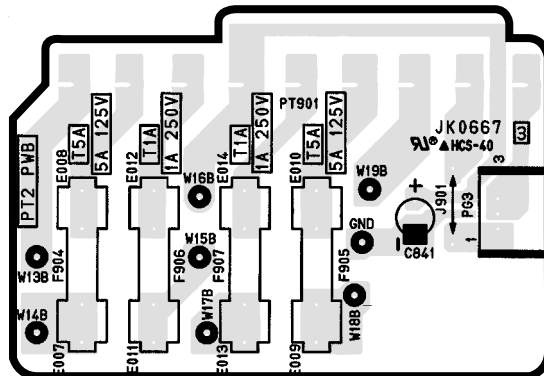

PT2 PWB

Soldering Side

Component Side

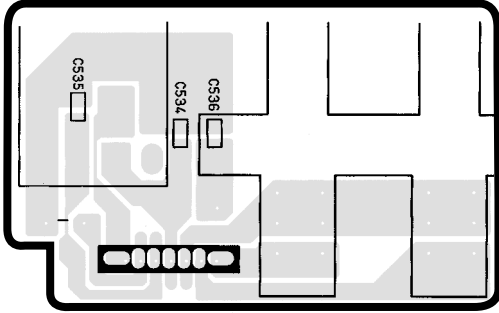

Phone PWB

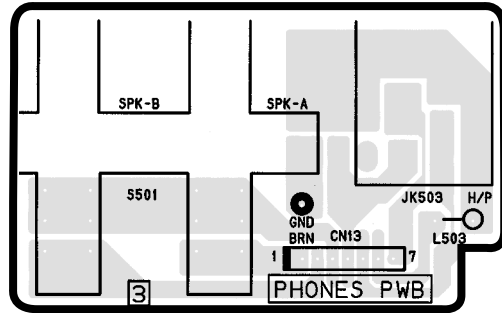

Phone PWB

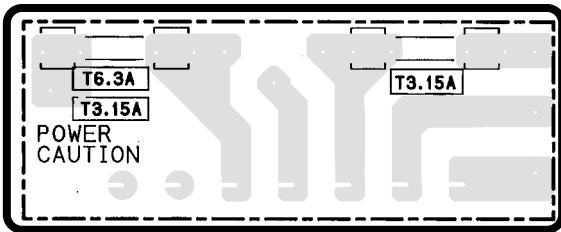

PT1 PWB

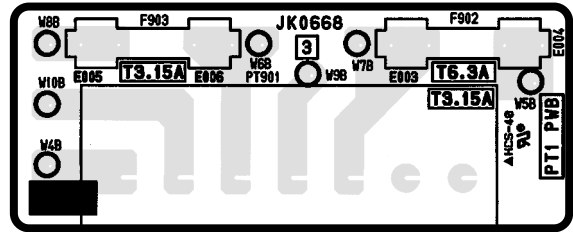

PT1 PWB

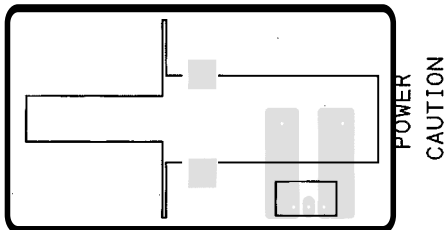

P-SW PWB

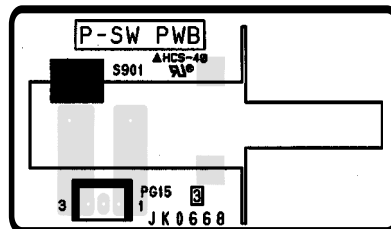

P-SW PWB

BLOCK DIAGRAM

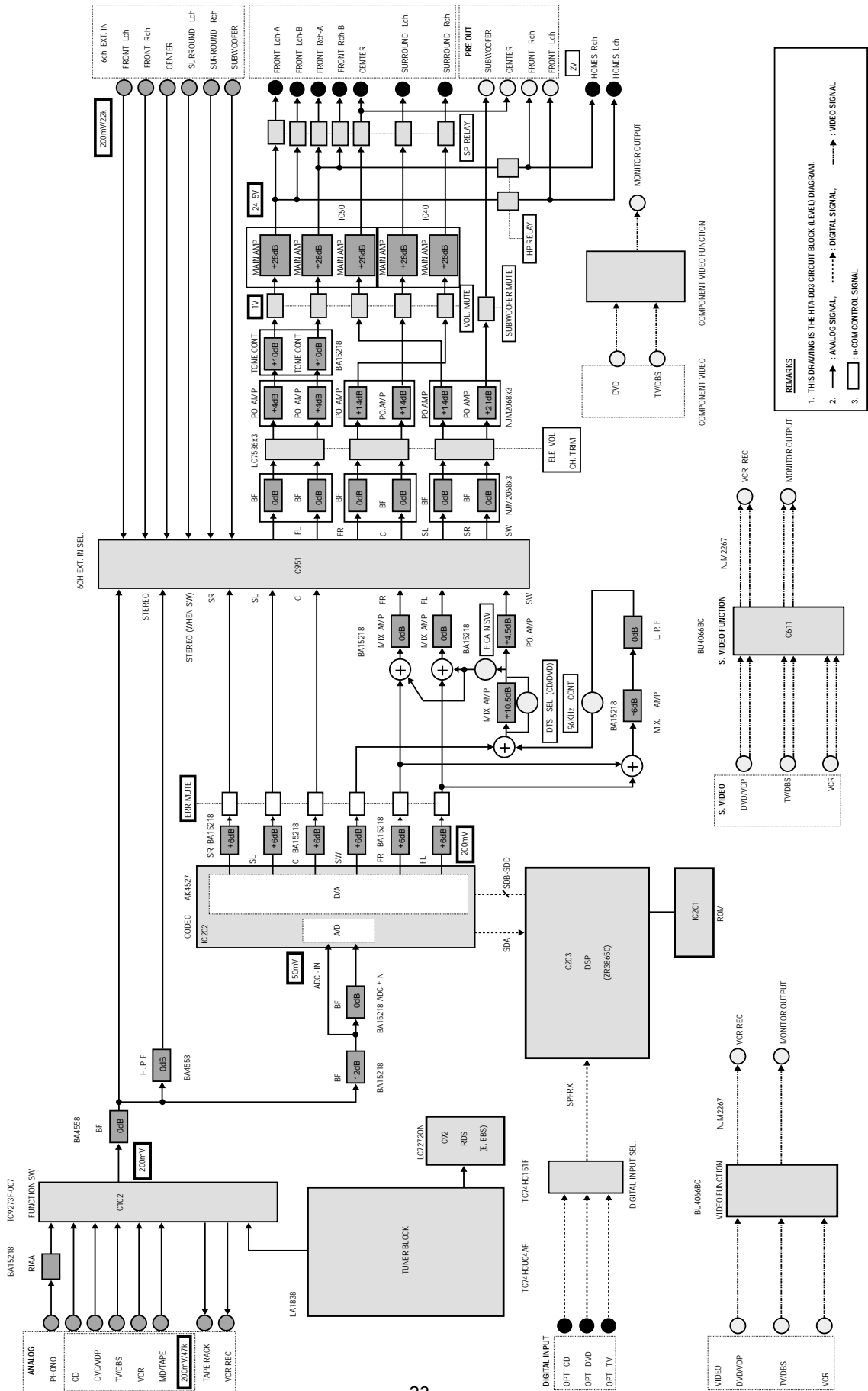

FLUSE	F904	F906	F908	F907
DEST.	SA 125V	SA 125V	SA 250V	SA 250V
E-ELEM	T5A	T5A	T1A	T1A
M-MAIN	T5A	T5A	T1A	T1A
J	T5A	T5A	T1A	T1A

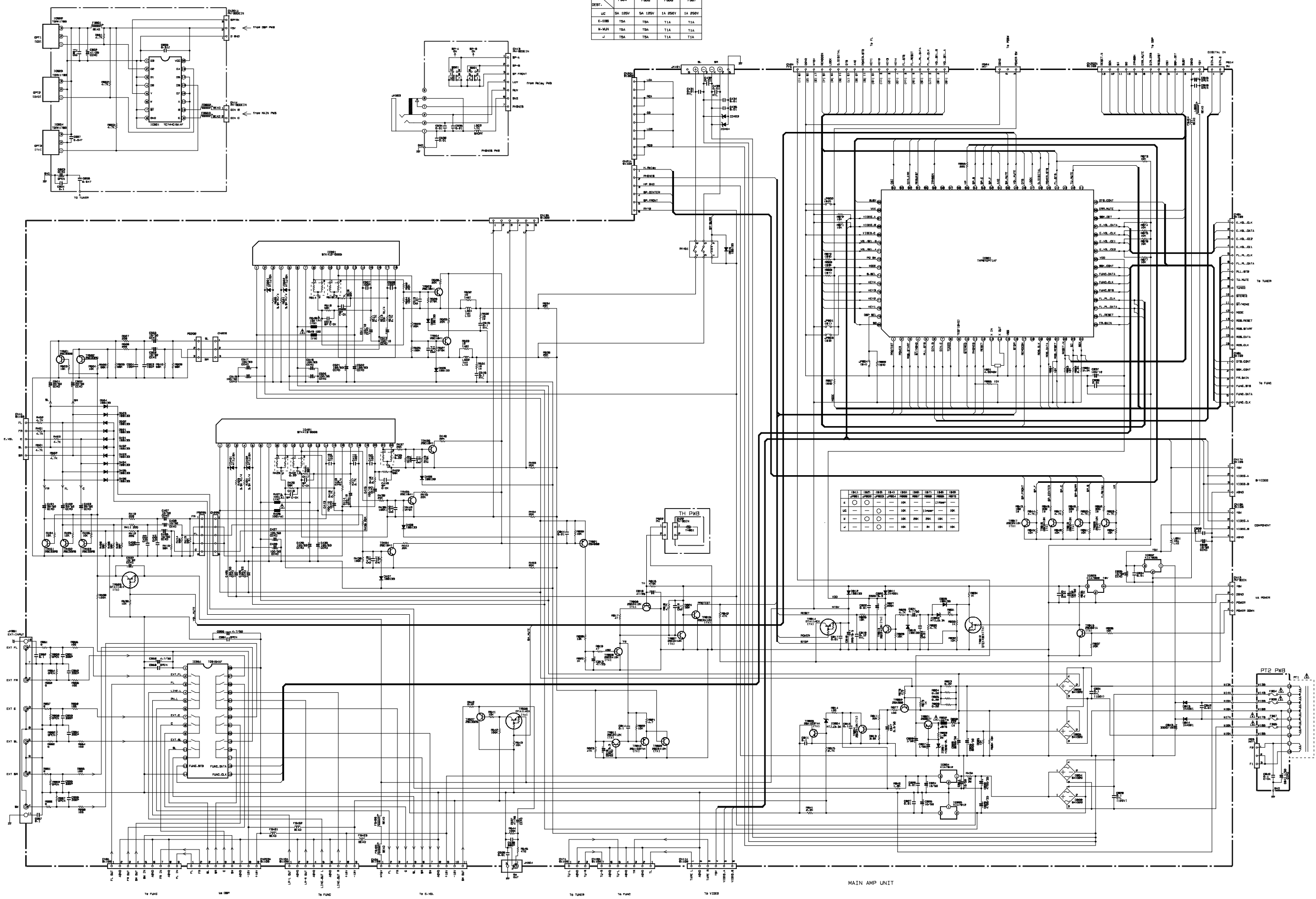

SM0103

MAIN CIRCUIT

HITACHI

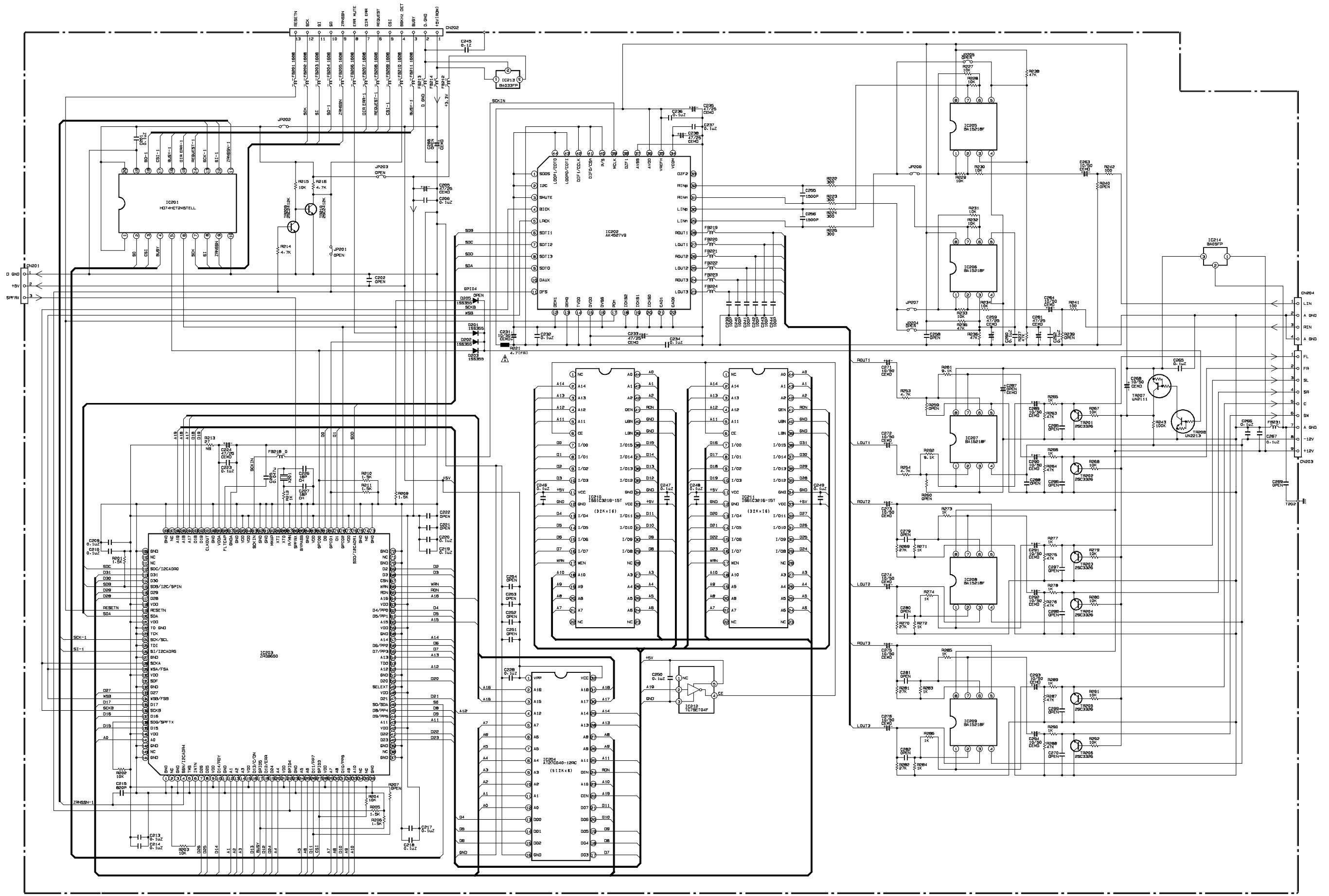

SM0103

DSP CIRCUIT

HITACHI

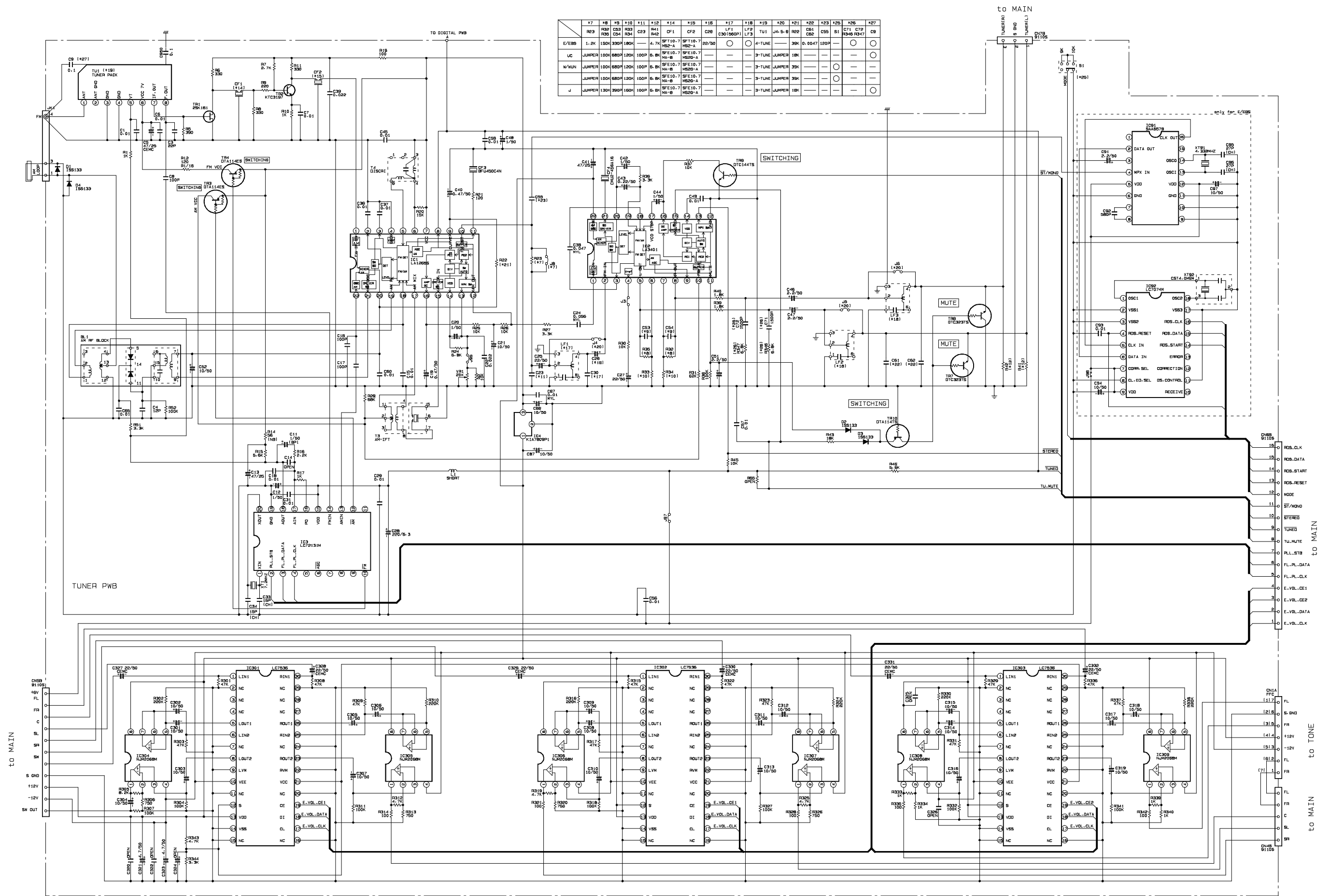

SM0103

TUNER CIRCUIT

HITACHI

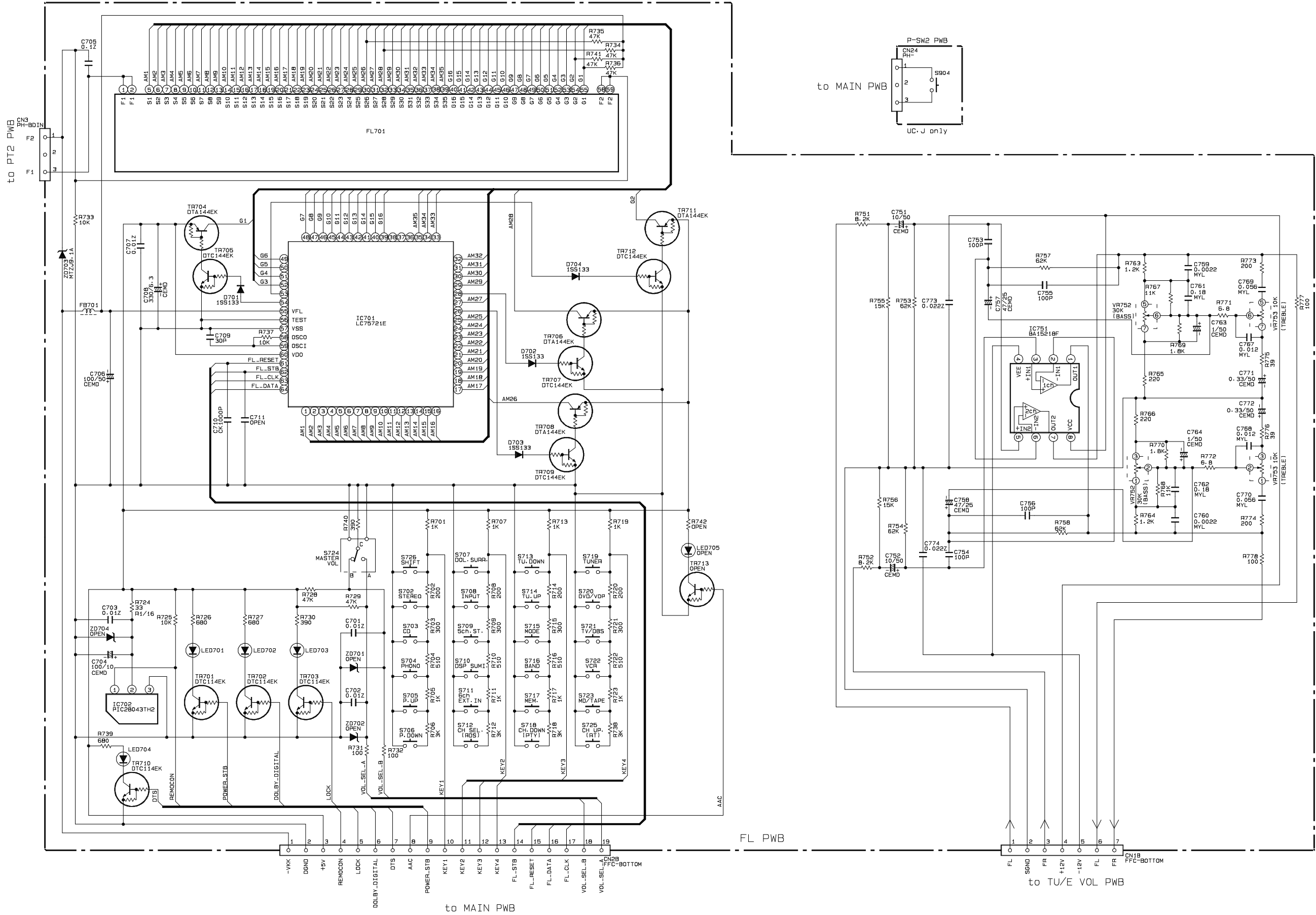

SM0103

FL CIRCUIT

HITACHI

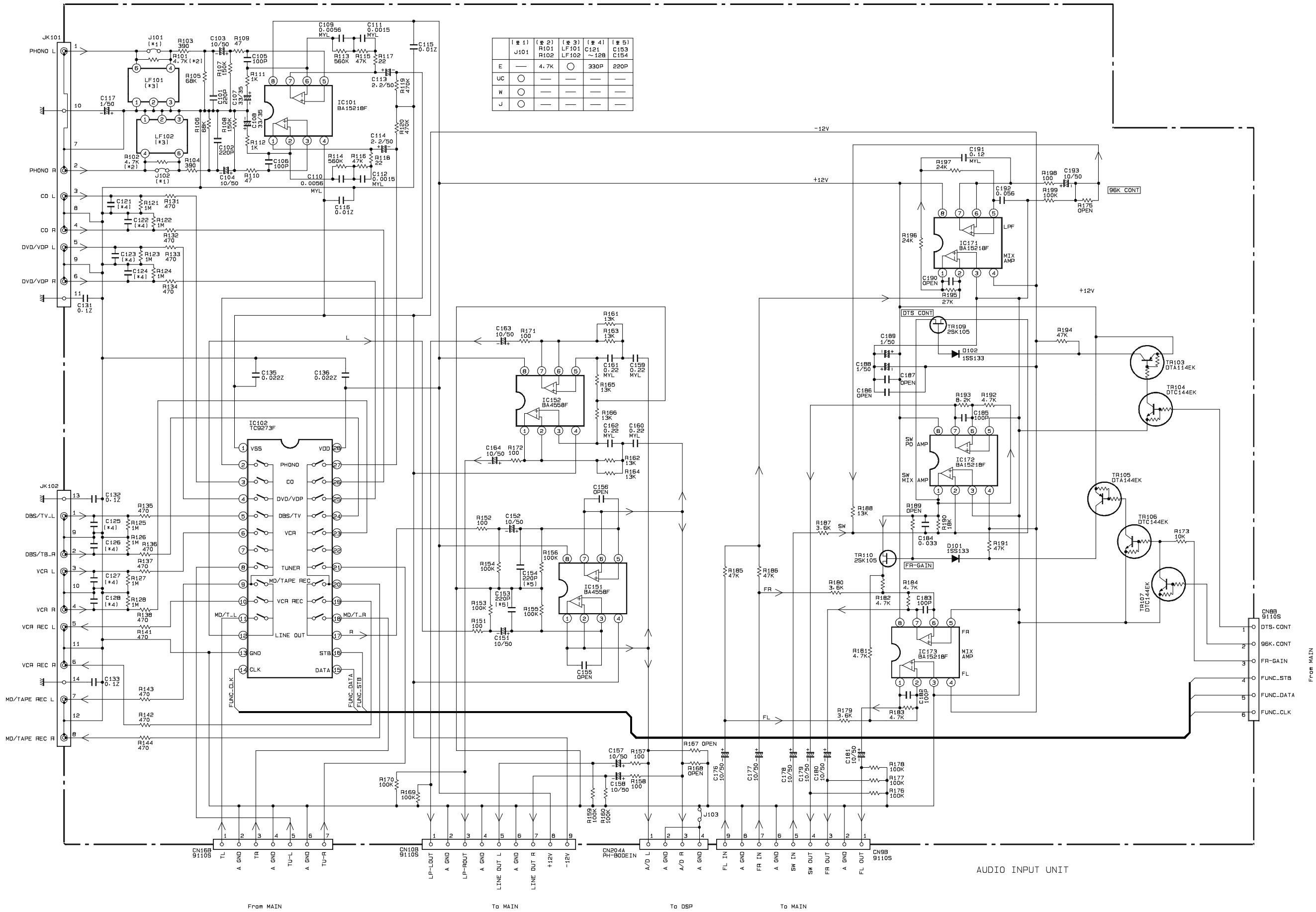

AUDIO INPUT UNIT

SM0103

AUDIO CIRCUIT

HITACHI

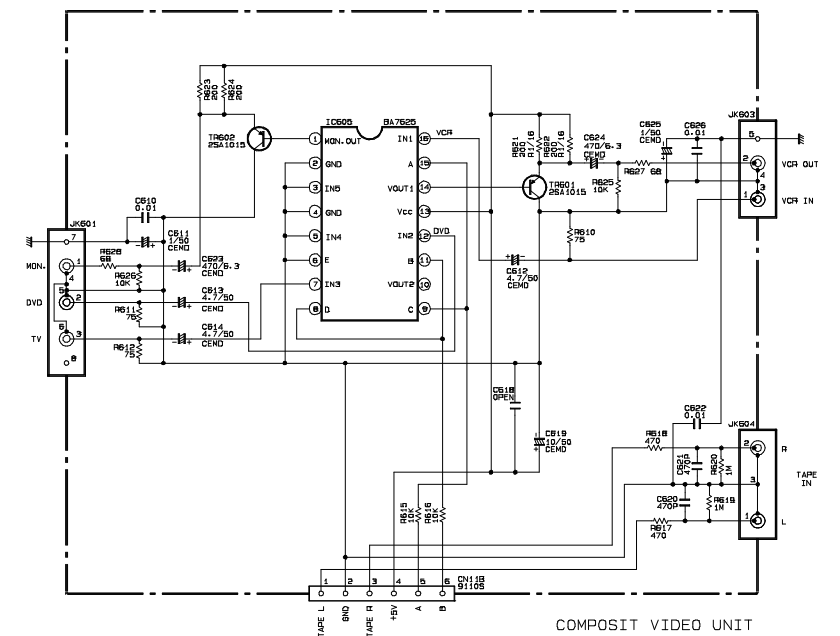
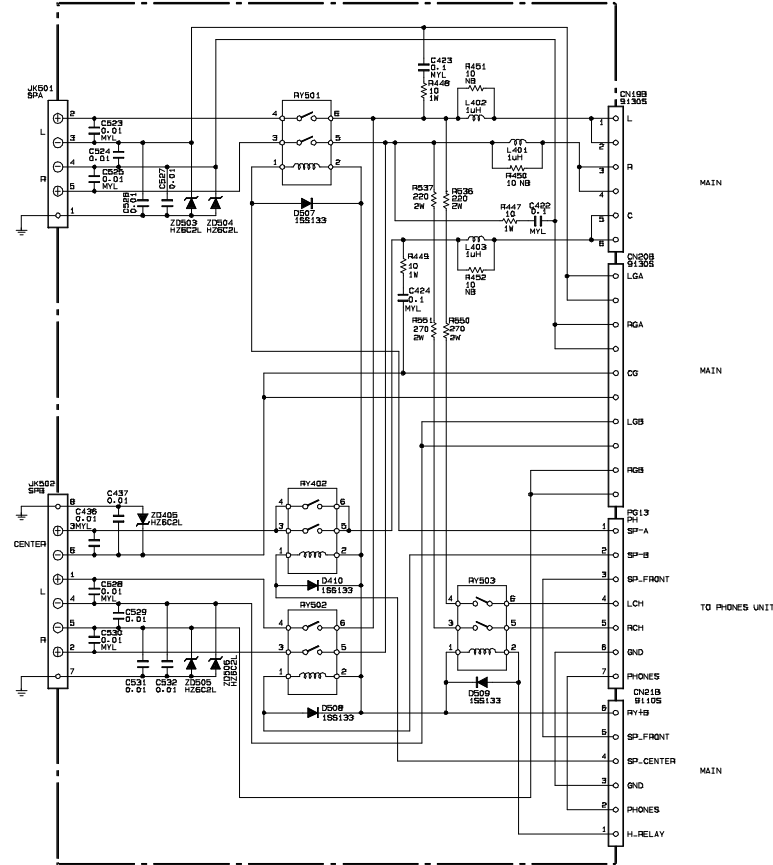
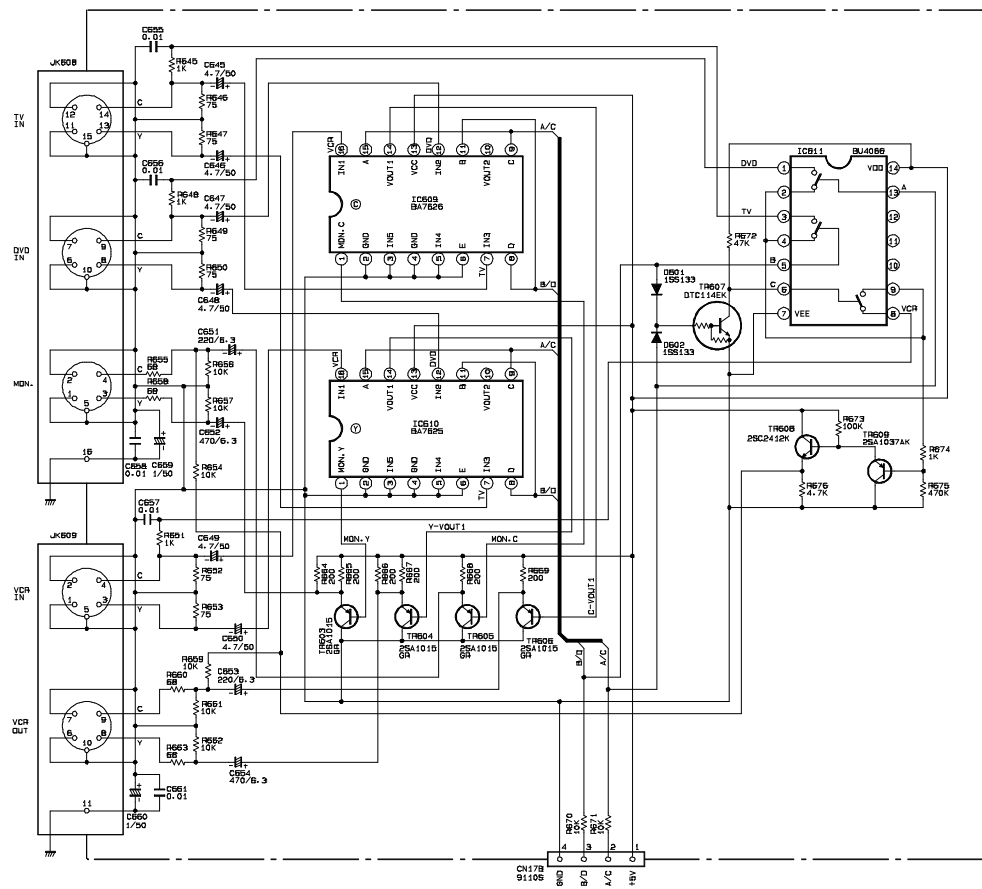

	(*1)	(*2)	(*3)	(*6)	(*8)	(*9)	(*10)	(*11)	(*12)	(*13)	(*14)	(*15)	(*16)
UC	T6. 3A	T6. 3A	—	—	—	—	—	—	—	—	—	—	—
E. EBS. EK	—	T3. 15A	—	—	—	—	—	—	—	—	—	—	—
W. NUN. MAU	—	T6. 3A	T3. 15A	—	—	—	—	—	—	—	—	—	—
J	T6. 3A	T6. 3A	—	—	—	—	—	—	—	—	—	—	—

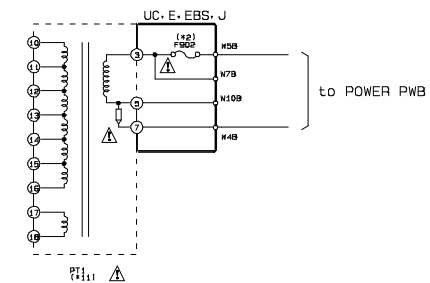
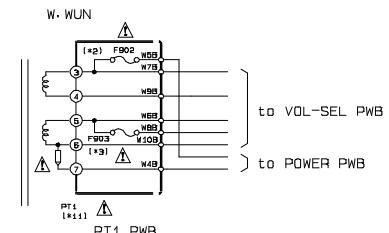
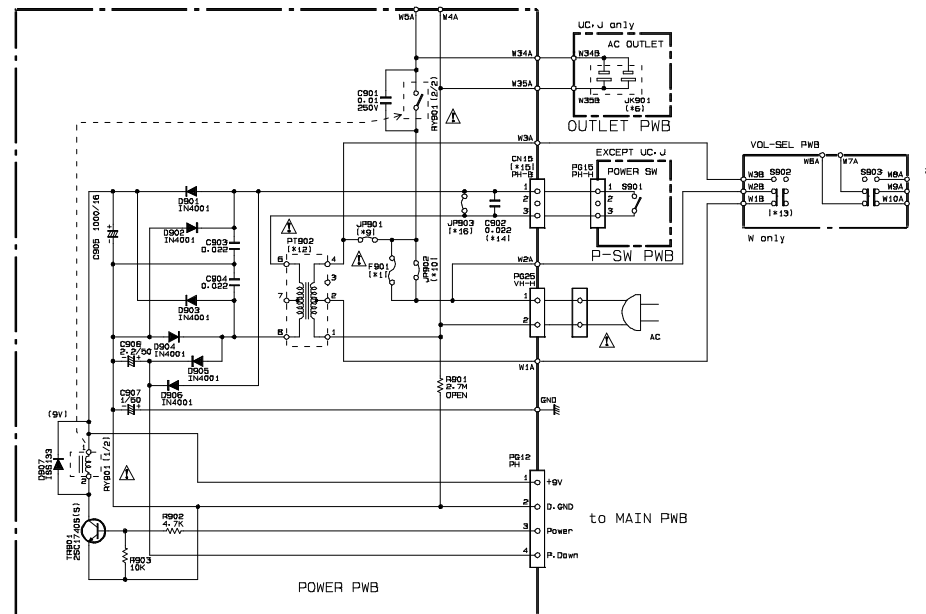
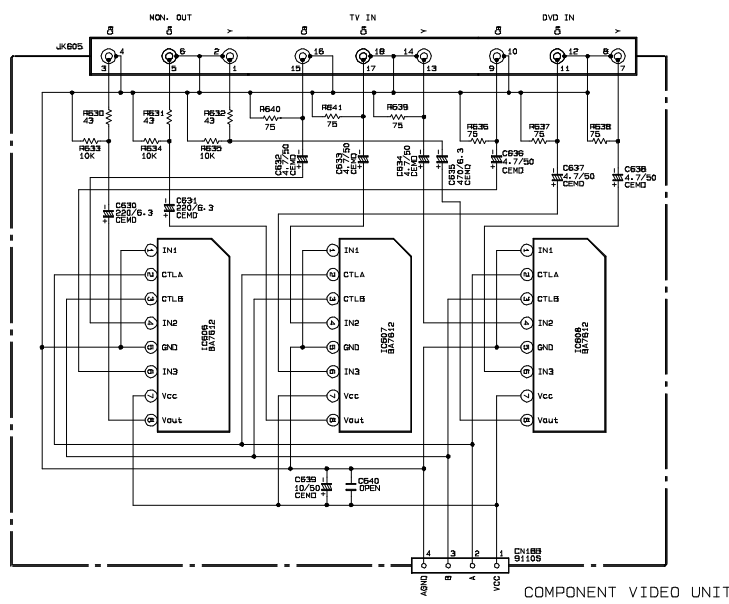

EXPLODED VIEW (Cabinet Chassis)

• Nos. are reference Nos. of part list

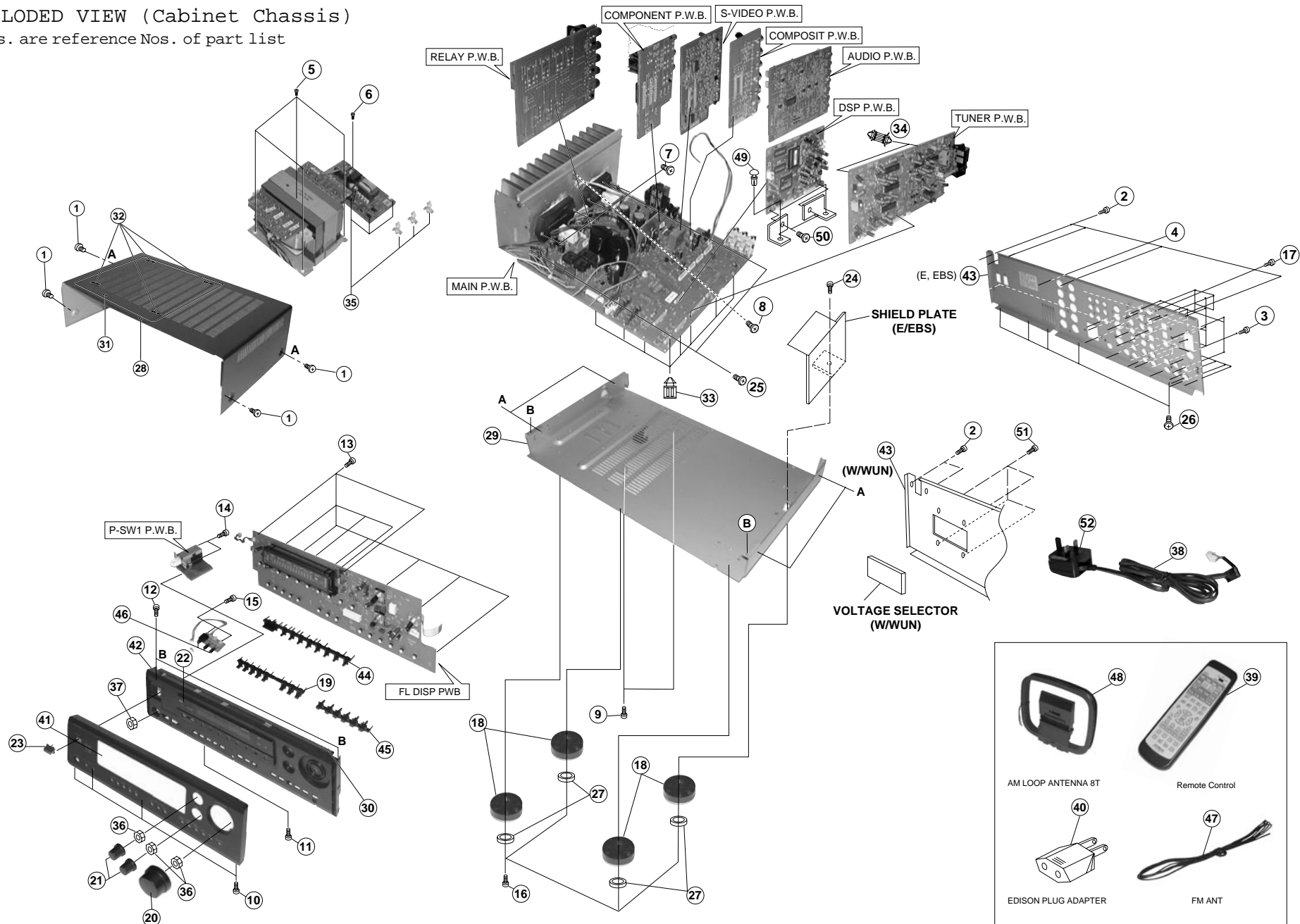

**THE UPDATED PARTS LIST
FOR THIS MODEL IS
AVAILABLE ON ESTA**

HITACHI

Hitachi, Ltd. Tokyo, Japan
International Sales Division
THE HITACHI ATAGO BUILDING,
No. 15-12 Nishi Shinbashi, 2 - Chome,
Minato - Ku, Tokyo 105-8430, Japan.
Tel: 03 35022111

HITACHI EUROPE LTD,

Whitebrook Park
Lower Cookham Road
Maidenhead
Berkshire
SL6 8YA

UNITED KINGDOM

Tel: 01628 643000
Fax: 01628 643400
Email: consumer-service@hitachi-eu.com

HITACHI EUROPE S.A.

364 Kifissias Ave. & 1, Delfon Str.
152 33 Chalandri
Athens

GREECE

Tel: 1-6837200
Fax: 1-6835964
Email: service.hellas@hitachi-eu.com

HITACHI EUROPE GmbH

Munich Office
Dornacher Strasse 3
D-85622 Feldkirchen bei München

GERMANY

Tel: +49-89-991 80-0
Fax: +49-89-991 80-224
Hotline: +49-180-551 25 51 (12ct/min)
Email: HSE-DUS.service@hitachi-eu.com

HITACHI EUROPE S.A.

Gran Via Carlos III, 101-1
08028 Barcelona

SPAIN

Tel: 93 409 2550
Fax: 93 491 3513
Email: atencion.cliente@hitachi-eu.com

HITACHI EUROPE srl

Via Tommaso Gulli N.39, 20147
Milano, Italia

ITALY

Tel: +39 02 487861
Tel: +39 02 38073415 Servizio Clienti
Fax: +39 02 48786381/2
Email: customerservice.italy@hitachi-eu.com

HITACHI Europe AB

Box 77 S-164 94 Kista

SWEDEN

Tel: +46 (0) 8 562 711 00
Fax: +46 (0) 8 562 711 13
Email: csgswe@hitachi-eu.com

HITACHI EUROPE S.A.S

Lyon Office
B.P. 45, 69671 BRON CEDEX

FRANCE

Tel: 04 72 14 29 70
Fax: 04 72 14 29 99
Email: france.consommateur@hitachi-eu.com

HITACHI EUROPE LTD (Norway) AB

STRANDVEIEN 18

1366 Lysaker

NORWAY

Tel: 67 5190 30
Fax: 67 5190 32
Email: csgnor@hitachi-eu.com

HITACH EUROPE AB

Egebækgård
Egebækvej 98
DK-2850 Nærum

DENMARK

Tel: +45 43 43 6050
Fax: +45 43 60 51
Email: csgnor@hitachi-eu.com

HITACHI EUROPE AB

Neopoli / Niemenkatu 73
FIN-15140 Lahti

FINLAND

Tel : +358 3 8858 271
Fax: +358 3 8858 272
Email: csgnor@hitachi-eu.com

Hitachi Europe Ltd

Bergensesteenweg 421
1600 Sint-Pieters-Leeuw

BELGIUM

Tel: +32 2 363 99 01
Fax: +32 2 363 99 00
Email: sofie.van.bom@hitachi-eu.com

HITACHI EUROPE LTD

Na Sychrove 975/8
101 27 Praha 10 - Bohdalec

CZECH REPUBLIC

Tel: +420 267 212 383
Fax: +420 267 212 385
Email: csgnor@hitachi-eu.com

www.hitachidigitalmedia.com