

HITACHI

SERVICE MANUAL

TY

No. 317 EGF

320

HTD-G2



CONTENTS

SPECIFICATIONS	1
FEATURES	3
DISASSEMBLY	3
ADJUSTMENT	5
LUBRICATION	12
PRINTED WIRING BOARD	13,15,17,19
CIRCUIT DIAGRAM	14,16,18
BLOCK DIAGRAM	20
WIRING DIAGRAM	21
EXPLODED VIEW	22
REPLACEMENT PARTS LIST	24
FRONT AND REAR PANEL	33

SAFETY PRECAUTIONS

The following precautions should be observed when servicing.

1. Since many parts in the unit have special safety related characteristics, always use genuine Hitachi's replacement parts. Especially critical parts in the power circuit block should not be replaced with other makers. Critical parts are marked with Δ in the schematic diagram and circuit board diagram.
2. Before returning a repaired unit to the customer, the service technician must thoroughly test the unit to ascertain that it is completely safe to operate without danger of electrical shock.

SPECIFICATIONS

GENERAL SPECIFICATIONS

Power supply:	AC 120V (60 Hz) ~ 100 - 120V/200 - 240V (50/60 Hz) ~ 220 (50 Hz), ~ 240V (50 Hz)
Power consumption:	40W
Dimensions:	320 (W) x 137 (H) x 276 (D) mm
Weight:	5.2 kg

FM SECTION

Frequency range:	87.5 to 108 MHz (0.05 MHz step)
Sensitivity:	1.9 μ V (IHF and DIN)
Image interference ratio:	47 dB
IF interference ratio:	95 dB
Total harmonic distortion:	MONO: 0.1%, STEREO: 0.2%
Signal-to-noise ratio:	MONO: 70 dB, STEREO: 66 dB
Selectivity:	50 dB
AM suppression ratio:	50 dB

AM (MW) SECTION

Frequency range:	522 to 1611 kHz (9 kHz step) 530 to 1620 kHz (10 kHz step)
Sensitivity:	15 μ V
Selectivity:	30 dB
Signal-to-noise ratio:	52 dB (at 50 mV/m)

LW SECTION (for Switzerland, Sweden, U.K., Australia & W. Germany)

Frequency range:	155 to 353 kHz (9 kHz sep)
Sensitivity:	100 μ V
Signal-to-noise ratio:	48 dB

TAPE DECK SECTION

Frequency response:	NORMAL: 20 to 15,000Hz CrO ₂ : 20 to 16,000 Hz METAL: 20 to 17,000 Hz
Signal-to-noise ratio:	DOLBY NR OFF: 58 dB DOLBY B NR ON: 66 dB DOLBY C NR ON: 71 dB
Wow and Flutter:	0.04% (WRMS)

PREAMP SECTION

Input sensitivity/impedance:	DAD/AUX: 170 mV/28 ohms PHONO: 2.6 mV/47 kohms MIC: 0.8 mV/4 kohms
Output level/impedance:	130 mV/3 kohms
Equalizer:	PHONO: RIAA \pm 0.5 dB
Signal-to-noise ratio:	DAD/AUX: 97 dB (IHF A network) PHONO: 80 dB (IHF A network) MIC: 59 dB (IHF A network)
BASS CONTROL:	\pm 8 dB (100 Hz), \pm 8 dB10 kHz)
Loudness control:	+6.5 dB (100 Hz), +4 dB10 kHz)

SPECIFICATIONS AND PARTS ARE SUBJECT TO CHANGE FOR IMPROVEMENT.

STEREO TUNER DECK

May 1982 TOYOKAWA WORKS

320

SICHERHEITSMASSNAHMEN

Bei Wartungsarbeiten sind die folgenden Sicherheitsmaßnahmen zu beachten:

1. Da verschiedene Teile dieses Gerätes Sicherheitsfunktionen aufweisen, nur Original-Hitachi-Ersatzteile verwenden. Kritische Teile im Netzteil sollten nicht durch ähnliche Teile anderer Hersteller ersetzt werden. Alle kritischen Teile sind im Schaltplan und im Diagramm der Schaltplatinen mit dem Symbol Δ gekennzeichnet.
2. Vor der Auslieferung eines reparierten Gerätes an den Kunden muß der Wartungstechniker das Gerät einer gründlichen Prüfung unterziehen, um sicherzustellen, daß sicherer Betrieb ohne die Gefahr von elektrischen Schlägen gewährleistet ist.

TECHNISCHE DATEN

ALLGEMEINE TECHNISCHE DATEN

Stromversorgung:	Wechselstrom 120V (60 Hz) 100 – 120V/200 – 240V (50/60 Hz) 220V (50 Hz), 240V (50 Hz)
Leistungsaufnahme:	40 Watt
Abmessungen:	320 (B) x 137 (H) x 276 (T) mm
Gewicht:	5,2 kg

UKW-TEIL

Frequenzbereich:	87,5 – 108 MHz (in Schritten von 0,05 MHz)
Empfindlichkeit:	1,9 μ V (IHF und DIN)
Spiegelfrequenzsicherheit:	47 dB
ZF-Unterdrückung:	95 dB
Gesamtklirrfaktor:	MONO: 0,1%, STEREO: 0,2%
Geräuschspannungsabstand:	MONO: 70 dB, STEREO: 66 dB
Gleichwellenselektion:	50 dB
AM-Unterdrückung:	50 dB

AM (MW)-TEIL

Frequenzbereich:	522 bis 1,611 kHz (in Schritten von 9 kHz) 530 bis 1,620 kHz (in Schritten von 10 kHz)
Empfindlichkeit:	15 μ V
Gleichwellenselektion:	30 dB
Geräuschspannungsabstand:	52 dB (bei 50 mV/m)

LW-TEIL (für die Schweiz, Schweden, England, Australien und Westeuropa)

Frequenzbereich:	155 bis 353 kHz (in Schritten von 9 kHz)
Empfindlichkeit:	100 μ V
Geräuschspannungsabstand:	48 dB

BANDGERÄT-TEIL

Frequenzgang:	NORMAL: 20 bis 15.000 Hz CrO ₂ : 20 bis 16.000 Hz METAL: 20 bis 17.000 Hz
Geräuschspannungsabstand:	DOLBY NR OFF: 58 dB DOLBY B NR ON: 66 dB DOLBY C NR ON: 71 dB 0,04% (WRMS)
Gleichlaufschwankungen:	0,04% (WRMS)

VORVERSTÄRKER-TEIL

Eingangsempfindlichkeit/Impedanz:	DAD/AUX: 170 mV/28 kOhm PHONO: 2,6 mV/47 kOhm MIC: 0,8 mV/4 kOhm
Ausgangspegel/Impedanz:	130 mV/3 kOhm
Entzerrer:	PHONO: RIAA \pm 0,5 dB
Geräuschspannungsabstand:	DAD/AUX: 97 dB (IHF A-Netz) PHONO: 80 dB (IHF A-Netz) MIC: 59 dB (IHF A-Netz)
Baßregler:	\pm 8 dB (bei 100 Hz), \pm 8 dB (bei 10 kHz)
Lautstärkekonturregler:	+6,5 dB (bei 100 Hz), +4 dB (bei 10 kHz)

PRÉCAUTIONS DE SÉCURITÉ

Les précautions suivantes doivent être observées chaque fois qu'une réparation doit être faite.

1. Étant donné que de nombreux composants de l'appareil possèdent des caractéristiques relatives à la sécurité, utiliser uniquement des pièces de rechange d'origine Hitachi pour effectuer un remplacement. Ceci se rapporte notamment aux pièces critiques du bloc d'alimentation qui ne doivent en aucun cas être remplacées par celles d'autres fabricants. Les pièces critiques sont accompagnées du symbole Δ dans le schéma de montage et sur le schéma de plaque de câblage.
2. Avant de retourner l'appareil réparé au client, le technicien doit procéder à un essai complet pour s'assurer qu'il ne présente aucun danger de chocs électriques.

CARACTERISTIQUES

CARACTERISTIQUES GÉNÉRALES

Alimentation:	CA 120V (60 Hz) ~ 100 – 120V/200 – 240V (50/60 Hz) ~ 220V (50 Hz), ~ 240V (50 Hz)
Puissance:	40W
Dimensions:	320 (L) x 137 (H) x 276 (P) mm
Poids:	5,2 kg

SECTION FM

Gamme de fréquence:	87,5 à 108 MHz (étap de 0,05 MHz)
Sensibilité:	1,9 μ V (IHF et DIN)
Rapport de rejet d'image:	47 dB
Rapport de rejet FI:	95 dB
Distorsion harmonique totale:	MONO: 0,1%, STEREO: 0,2%
Rapport signal/bruit:	MONO: 70 dB, STEREO: 66 dB
Sélectivité:	50 dB

Rapport de suppression AM: 50 dB

SECTION AM (MW)

Gamme de fréquence:	522 à 1,611 kHz (étap de 9 kHz) 530 à 1,620 kHz (étap de 10 kHz)
Sensitivité:	15 μ V
Sélectivité:	30 dB
Rapport signal/bruit:	52 dB (à 50 mV/m)

SECTION LW (pour la Suisse, la Suède, le Royaume-Uni, l'Australie, et l'Allemagne de l'Ouest)

Gamme de fréquence:	155 à 353 kHz (étap de 9 kHz)
Sensitivité:	100 μ V
Rapport signal/bruit:	48 dB

SECTION DE PLATINE DE MAGNETOPHONE

Réponse en fréquence: NORMAL: 20 à 15.000 Hz
 CrO₂: 20 à 16.000 Hz
 METAL: 20 à 17.000 Hz
 Rapport signal/bruit: Sans DOLBY NR: 58 dB
 Avec DOLBY NR B: 66 dB
 Avec DOLBY VR C: 71 dB
 Pleurage et scintillement: 0,04% (WRMS)

SECTION PREAMPLIFICATEUR

Sensibilité d'entrée/Impédance: DAD/AUX: 170 mV/28 kohms
 PHONO: 2,6 mV/47 kohms
 MIC: 0,8 mV/4 kohms
 Niveau de sortie/impédance: 130 mV/3 kohms
 Egalisateur: PHONO: RIAA ±0,5 dB
 Rapport signal/bruit: DAD/AUX: 97 dB (réseau IHF A)
 PHONO: 80 dB (réseau IHF A)
 MIC: 59 dB (réseau IHF A)
 Contrôle des graves: ±8 dB (100 Hz), ±8 dB (10 kHz)
 Correction physiologique: +6,5 dB (100 Hz), +4 dB (10 kHz)

FEATURES · MERKMALE · CARACTÉRISTIQUES

1. IC logic control for tape deck buttons for feather-touch operation
2. Compatibility with metal tapes which exhibit a good sound quality
3. Built-in Dolby Type B and Type C noise reduction systems
4. Timer recording and timer playback
5. Auto rec mute function which automatically creates unrecorded blanks lasting for 4 seconds
6. Quartz synthesizer system with superb tuning accuracy
7. Mic mixing capability
8. Convenient arrangement of recording output and auxiliary input terminals on front panel

1. IC-Logiksteuerung der Bedienungstasten des Bandgerätes für federleichte Bedienung.
2. Metallband-Kompatibilität ermöglicht die Verwendung von Metallbändern mit ihren ausgezeichneten Klangeigenschaften.
3. Eingebaute Dolby-Rauschunterdruckungssysteme B und C.
4. Timer-Aufnahme und Timer-Wiedergabe.
5. Automatisches Aufnahme-Muting, eine Funktion, die automatisch Leerstellen von 4 Sekunden Dauer auf dem Band einfügt.
6. Quarzsynthesizer-System mit hervorragender Abstimmgenauigkeit.
7. Einrichtung für Mikrofonmischen.
8. Bequeme Anordnung von Aufnahme Ausgangsbuchse und Eingangsbuchse für Zusatz geräte an der Frontplatte.

1. La commande numérique par CI des boutons du magnétophone assure une exploitation par simple effleurement.
2. La compatibilité avec les bandes métal assure une bonne qualité sonore.
3. Des réducteurs de bruit Dolby de type B et de type C sont intégrés à l'appareil.
4. Enregistrement et lecture possibles par programmeur.
5. La fonction automatique de silencieux d'enregistrement crée automatiquement des espaces vierges de 4 secondes.
6. Un système de synthétiseur par quartz assure une remarquable précision d'accord.
7. Possibilité de mixage par microphone.
8. Les bornes de sortie d'enregistrement et d'entrée auxiliaires situées sur le panneau avant sont une caractéristique pratique.

DISASSEMBLY · AUSBAUANWEISUNG · DÉMONTAGE

1. Cover · Abdeckung · Couvercle

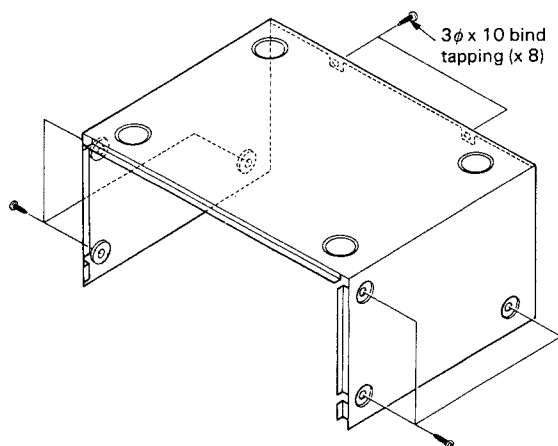

2. Bottom cover · Untere Abdeckung · Couvercle inférieur

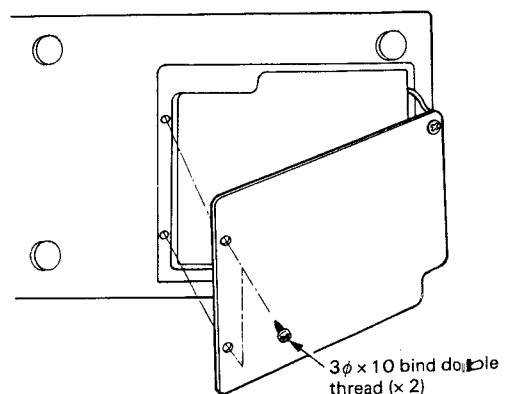

**3. Cassette door · Cassetentür ·
Trappe de logement de cassette**

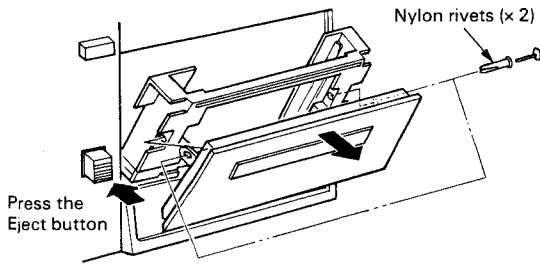

4. Front panel · Frontplatte · Panneau avant

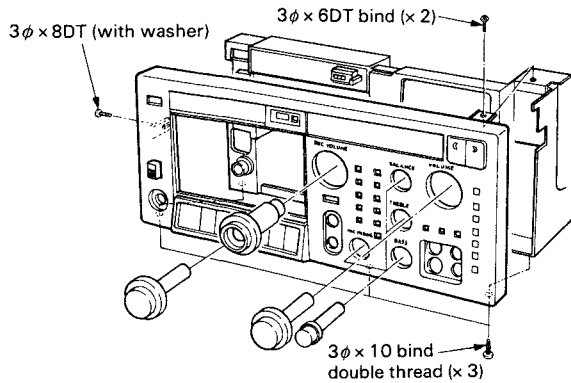

**5. DECK switch and PRESET switch ·
DECK-Schalter und PRESET-Schalter ·
Interrupteur de platine (DECK) et interrupteur de pré réglage (PRESET)**

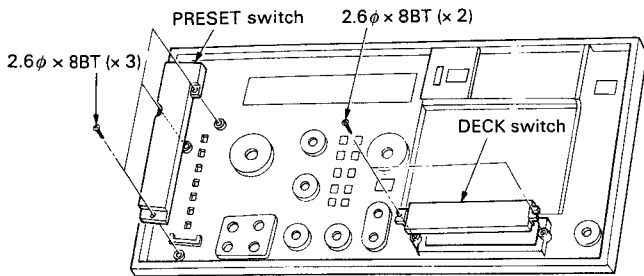

**6. TU P.W.B. · TU Gedruckte Schaltung ·
Plaque CI TU**

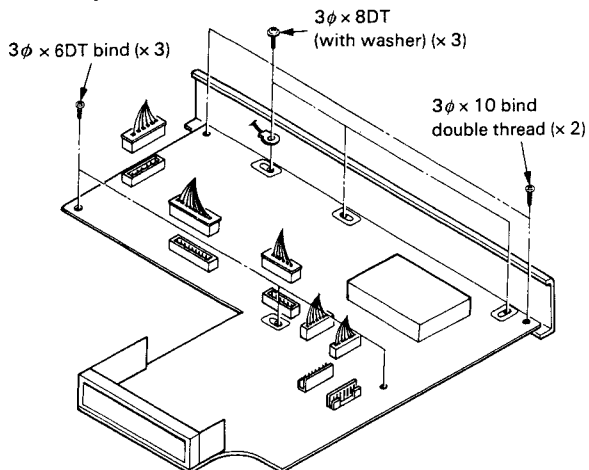

**7. LED P.W.B. · LED Gedruckte Schaltung ·
Plaque CI LED**

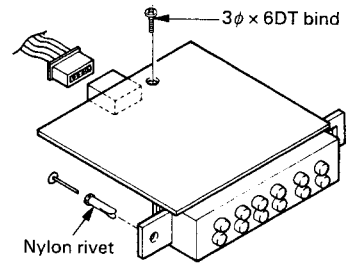

**8. Shield plate · Abschirmplatte ·
Plaque de protection**

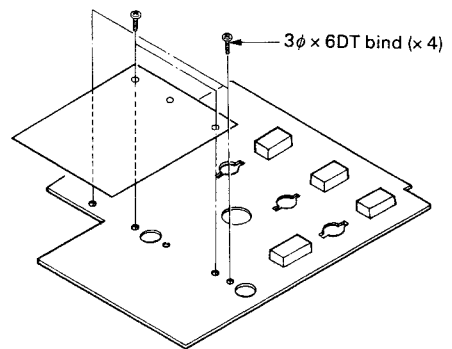

9. Front chasses · Frontchassis · Châssis avant

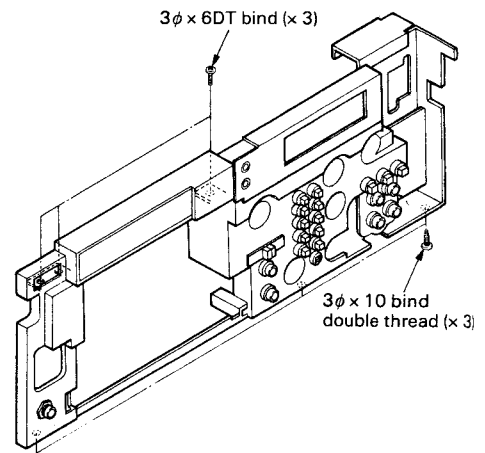

**10. PA P.W.B. · PA Gedruckte Schaltung ·
Plaque CI PA**

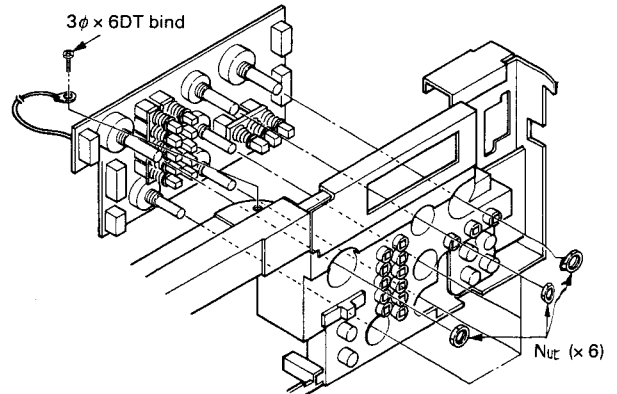

11. Tape deck section · Tonbanddeck-Teil ·
Section platine de magnétophone

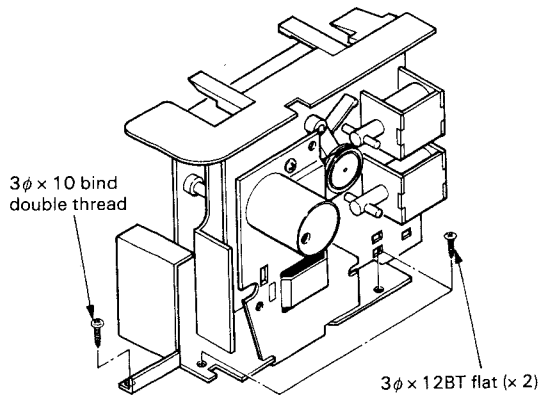

12. DE P.W.B. · DE Gedruckte Schaltung ·
Plaquette CI DE

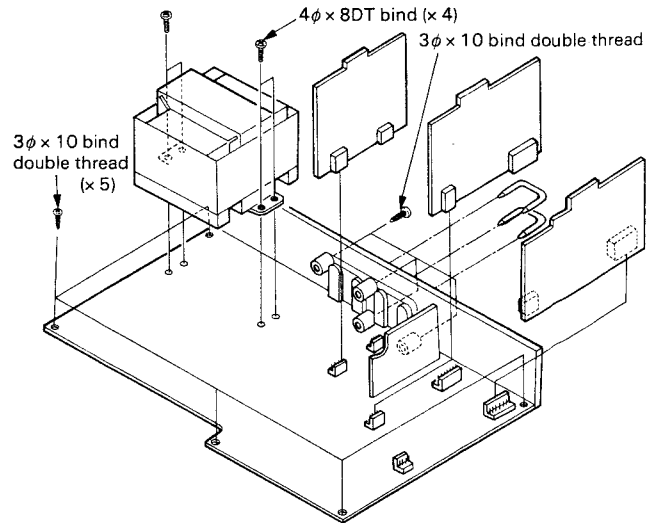

● **Memory back-up**

The memory circuit power supply employs a capacitor back-up system. With this system, the preset stations are backed up for approx. 1 week at power failure. If the unit is not used for a long period of time, the preset stations are erased. At that time, preset the stations again.

● **Speicherreserve**

Im Reservesystem Spannungsversorgungsschaltung des Speichers wird ein Kondensator verwendet. Durch dieses System werden voreingestellte Sender für ca. 1 Woche nach einem Spannungsausfall beibehalten. Wird das Gerät über einen längeren Zeitraum nicht, werden die voreingestellten Sender gelöscht. Wenn dies der Fall ist, die Sender erneut voreinstellen.

● **Support de mémoire**

Le circuit de mémoire est doté d'un système d'alimentation secondaire à condensateur. Grâce à ce système, les émetteurs présélectionnés restent en mémoire pendant environ 1 semaine même si l'alimentation secteur est coupée. Cependant, le contenu de la mémoire est effacé si l'appareil n'est pas mis sous tension pendant une période excédant une semaine. Il est alors nécessaire de procéder à nouveau à la mise en mémoire des émetteurs.

ADJUSTMENT · EINSTELLUNGEN · RÉGLAGE

General alignment instruction · Allgemeine ausrichtanleitung ·
Instructions generales

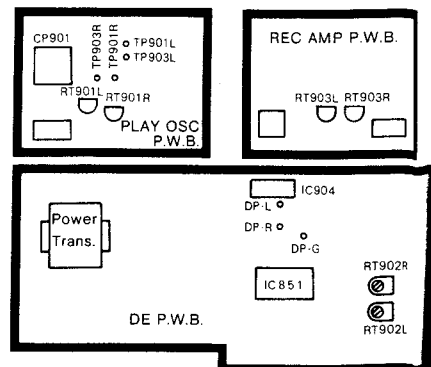
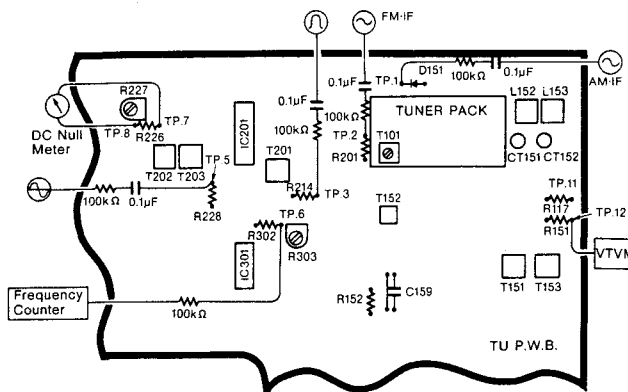

TUNER SECTION

TUNER SEKTION

SECTION TUNER

FM tuner alignment · Abgleich des UKW-tuners · Reglage de tuner FM

CONDITION
BEDINGUNG
ETAT

FUNCTION: FM
FUNKTION: FM
FUNCTION: FM

VOLUME: Min
LAUTSTÄRKE: Minimum
VOLUME: min.

FM MODE: MONO
MODO MF: MONO
UKW-MODO: MONO

 Sweep Generator
Wobbelgenerator
Générateur de balayage

 Signal Generator
Signalgenerator
Générateur de signaux

 Oscilloscope
Oszilloskop
Oscilloscope

 + DC Null Meter
Gleichstrom-Nullmeter
- Indicateur d'équilibrage à C.C.

 VTVM
V.T.V.M.
Voltmètre électronique

 Frequency Counter
Frequenzzähler
Fréquencecetre

 Dist. Distortion Meter
Klirrmesser
Distorsionmètre

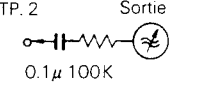
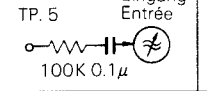
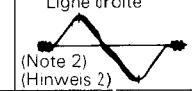
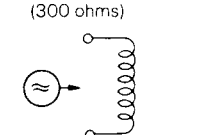
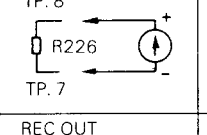
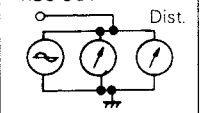
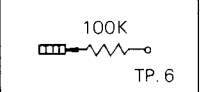
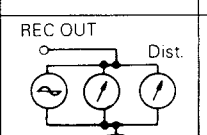
Sequence Folge Ordre	Connection Anschlüsse Connexion		Setting Einstellung Montage		Adjust for Einstellung für Réglage pour	
	Input Eingang Entrée	Output Ausgang Sortie	Tuning Abstimm- anzeige Indicateur d'accord	Signal Signal Signal	Adjust for Einstellung Réglage	Indication Indikation Indication
1	"S" curve S-Kurve Courbe TP. 2  0.1µ 100K	OUT Ausgang Sortie TP. 5 IN Eingang Entrée  100K 0.1µ	-	10.7 MHz	T203: "S" curve S-Kurve Courbe en forme de "S" T202: Straight Line Straight Linie Ligne droite	Straight line Gerade Linie Ligne droite  (Note 2) (Hinweis 2)
2	ANT. Terminal (300 ohms) 	TP. 8  TP. 7	98.1 or 98.00 MHz	98.1 or 98.00 MHz	T203	(Note 3; (Hinweis 3)
3	1 kHz, 60 dBµ 75 kHz (dev.) (for U.S.A. Canada) 40 kHz (dev.) (except U.S.A. Canada)	REC OUT 	98.1 or 98.00 MHz	98.1 or 98.00 MHz	T202	Distortion min. (Note 4; (Hinweis 4)
4			-			(Note 5; (Hinweis 5)
5			-			(Note 5; (Hinweis 5)
6	ANT. Terminal (300 ohms) 60 dBµ Non modulated Nicht moduliert Sans modulation	100K  TP. 6	98.1 or 98.00 MHz	98.1 or 98.00 MHz	R303	76 kHz ± 100 Hz
7	Mute bandwidth Largeur de bande sourdine Stillabtimungs- Bandbreite	ANT. Terminal 1 kHz, 40 kHz (dev.) 60 dBµ	REC OUT 	98.1 or 98.00 MHz (Mute sw. on)	98.00 MHz ± 60 kHz (U.S.A. & Canada) ± 30 kHz (others) Detuning	Mute ON by ± 60 ± 20 kHz (U.S.A. & Canada) ± 30 kHz ± 5 kHz (others) -10 kHz Detuning

(Note 1)

Perform adjustment at least 3 minutes after the power has been switched on.

(Note 2)

Adjust T203 and obtain an S-curve. Now adjust T202 and improve the linearity of the S-curve.

(Note 3)

Connect a DC null meter across R226, and adjust T203 for a reading of 0V ± 60 mV.

(Note 4)

When the distortion adjustment is performed, there will be a slight deviation in the discriminator adjustment performed under 3. Therefore, repeat adjustments 3 and 4 several times and adjust for a reading of 0V on the DC null meter with the distortion at its minimum.

(Note 5)

FM Tuner pack is aligned before shipping, so it is not necessary to adjust covering and tracking.

(Hinweis 1)

Den Abgleich frühestens 3 Minuten nach dem Einschalten des Netzschalters durchführen.

(Hinweis 2)

T203 abgleichen, um eine S-Kurve zu erhalten. Danach die Spule T202 nachjustieren, um die gerade Linie in der S-Kurve zu verbessern.

(Hinweis 3)

Einen Gleichspannungsmesser an R226 anschließen und T203 auf eine Anzeige von $0V \pm 60$ mV einstellen.

(Hinweis 4)

Wenn der Verzerrungsabgleich vorgenommen wird, kommt es zu einer kleinen Änderung der in Punkt 3 durchgeführten Diskriminator-Einstellung. Die Abgleiche 3 und 4 sind daher mehrmals zu wiederholen, bis der Spannungsmesser bei minimalen Verzerrungen $0V$ anzeigt.

(Hinweis 5)

Das UKW-Empfangsteil wurde vor dem Versand eingestellt, so daß der Bereich um die Nachführung nicht einjustiert werden müssen.

(Note 1)

Effectuer ce réglage au moins 3 minutes après la mise sous tension.

(Note 2)

Ajuster la bobine T203 pour obtenir une courbe en forme de "S". Ajuster ensuite la bobine T202 et améliorer la linéarité de la courbe en forme de "S".

(Note 3)

Connecter un zéromètre CC à travers R226, et régler T203 pour une lecture de $0V \pm 60$ mV.

(Note 4)

Quand le réglage de distorsion est réalisé, il existera un léger écart de réglage du discriminateur, opération qui est réalisée en 3. Par conséquent, les réglages 3 et 4 doivent être faits à plusieurs reprises de façon à obtenir une indication de $0V$ à l'indicateur de zéro à continu quand la distorsion est minimale.

(Note 5)

L'étage tuner FM est réglé avant son envoi, il est donc inutile d'effectuer le réglage de portée et d'alignement.

AM (MW) tuner alignment · Abgleich des AM (MW)-tuners · Réglage de tuner AM (MW)

CONDITION: FUNCTION: AM
MODULATION: 400 Hz 30%

BEDINGUNG: FUNKTION: AM
MODULATION: 400 Hz 30%

CONDITIONS: FONCTION: AM
MODULATION: 400 Hz 30%

Sequence Folge Ordre	Connection Anschlüsse Connexion		Setting Einstellung Montage		Adjust for Einstellung für Réglage pour	
	Input Eingang Entrée	Output Ausgang Sortie	Tuning Abstimm- anzeige Indicateur d'accord	Signal Signal Signal	Adjust for Einstellung Réglage	Indication Indication Indication
1	Out Ausgang Sortie TP. 1 0.1μ 100K	IN Eingang Entrée TP. 3 100K 0.1μ	-	450 kHz	T152 T201	 (Nce 6) (Hinweis 6)
2	Loop antenna Rahmenantenne Antenne en carton	TP. 12 GND 	530 kHz or 522 kHz	-	T151	(Nce 7) (Hinweis 7)
3	Tracking Vorstufe Alignement 	REC OUT 	600 kHz or 603 kHz 1400 kHz or 1404 kHz	600 kHz or 603 kHz 1400 kHz or 1404 kHz	L152 CT151	Output max. (Nce 8) (Hinweis 8)

(Note 6)

Adjust black cores of T152 and T201 so that the waveform is as shown in Fig. A. After adjusting as above, increase the output level of the sweep generator and adjust T152 and T201 again so that the top of the waveform A (indicated in Fig. B) will be flat and wide.

(Note 7)

Adjust T151 so that the DC voltmeter reads 2.0V (at 530 kHz) and 1.8V (at 522 kHz).

(Note 8)

Set the input level to 74 dB/m in coarse adjustment. Reduce the input level to minimum (60 dB/m) as adjustment proceeds.

HITACHI HTD-G2

(Hinweis 6)

Die schwarzen Kerne von T152 und T201 so einstellen, daß die Kurvenform der in Abb. A dargestellten entspricht. Nach der zuvor beschriebenen Einstellung den Ausgangspegel des Oszillators erhöhen und T152 und T201 abermals einstellen, so daß die Spitze der Kurvenform A (s. Abb. B) flach und breit wird.

(Hinweis 7)

T151 so abstimmen, daß der Gleichspannungs-Voltmeter 2,0V (bei 530 kHz) und 1,8V (bei 522 kHz) anzeigt.

(Hinweis 8)

Den Eingangspegel auf 74 dB/m grob einstellen. Auf minimal 60 dB/m nach Verlauf der Einstellung zurückstellen.

(Note 6)

Régler les âmes noires de T152 et T201 de façon à obtenir une forme d'onde comme indiquée sur la Fig. A. Après avoir réglé comme indiqué ci-dessus, augmenter le niveau d'entrée du générateur de balayage et régler T152 et T201 à nouveau de façon que le sommet de la forme d'onde A (voir Fig. B) soit aplati et large.

(Note 7)

Régler T151 de manière à ce que le voltmètre CC indique 2,0V (à 530 kHz) et 1,8V (à 522 kHz).

(Note 8)

Faire un réglage approximatif du niveau d'entrée à 74 dB/m. Réduire le niveau d'entrée jusqu'à un minimum de 60 dB/m à mesure que l'on effectue le réglage.

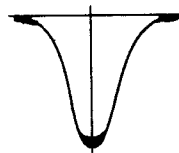

Fig. A Abb. A

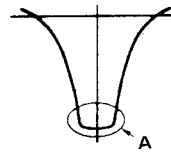

Fig. B Abb. B

LW tuner alignment · Abgleich des LW-tuners · Reglage de tuner LW

Sequence Folge Ordre	Connection Anschlüsse Connexion		Setting Einstellung Montage		Adjust for Einstellung für Réglage pour		
	Input Eingang Entrée	Output Ausgang Sortie	Tuning Abstimm- anzeige Indicateur d'accord	Signal Signal Signal	Adjust for Einstellungpunkt Réglage	Indication Indikation Indication	
1	Covering Abgleich Guipage	Loop antenna Rahmenantenne Antenne en carton	TP. 11 GND	155 kHz	-	T153	(Note 9) (Hinweis 9)
2	Tracking Vorstufe Alignement		REC OUT	164 kHz 335 kHz	164 kHz 335 kHz	L153 CT152	Output m ax. (Note 8) (Hinweis 8)

(Note 9)

Adjust T153 so that the DC voltmeter reads 2.3V.

(Hinweis 9)

T153 so einstellen, daß der Gleichstrom-Spannungsmesser 2,3V anzeigt.

(Note 9)

Régler T153 dans le manière que voltmètre de lire 2,3V.

TAPE DECK SECTION

KASSETTEN TEIL

SECTION MAGNETOPHONE

Perform the following adjustments in the sequence stated after cleaning the head, pressure roller, and capstan with a head cleaning stick moistened in alcohol. Also, unless specially indicated otherwise, set the switches and controls to the positions indicated in the table.

Die folgenden Einstellungen in der aufgeführten Reihenfolge durchführen, nachdem Tonköpfe, Andruckrolle und Tonwelle mit in Alkohol angefeuchtetem Reinigungsstäbchen gereinigt wurden. Die Schalter und Regler auf die in der Tabelle angegebenen Positionen einstellen, wenn nicht anders angegeben.

Effectuer les réglages suivants dans l'ordre indiqué après avoir nettoyé tête magnétique, galet-presseur et cabestan avec un stylet d'entretien de tête imprégné d'alcool. Par ailleurs, à moins qu'une indication contraire ne soit faite, régler les commutateurs et les commandes sur les positions spécifiées dans le tableau.

Symbol No. Symbol-Nr. No. de symbole	Switches and Controls Schalter und Regler Commutateurs et commandes	Position	Symbol No. Symbol-Nr. No. de symbole	Switches and Controls Schalter und Regler Commutateurs et commandes	Position
S901	Tape selector switch Bandsortenwahlschalter Sélecteur de bande	ER/UD (NORMAL)	RV901L, R	Record level controls Aussteuerungspegelregler Commande de niveau d'enregistrement	Maximum
S901	Dolby NR switch Dolby-NR-Schalter Commutateur du Dolby NR	OFF OFF (Aus) De niveau			

1. Tape speed adjustment

Setting: Playback mode
Connection:

1. Einstellung der Bandgeschwindigkeit

Betriebsart: Wiedergabe
Anschlüsse:

1. Réglage de défilement de la bande

Réglage préliminaire: Mode
Connexions:

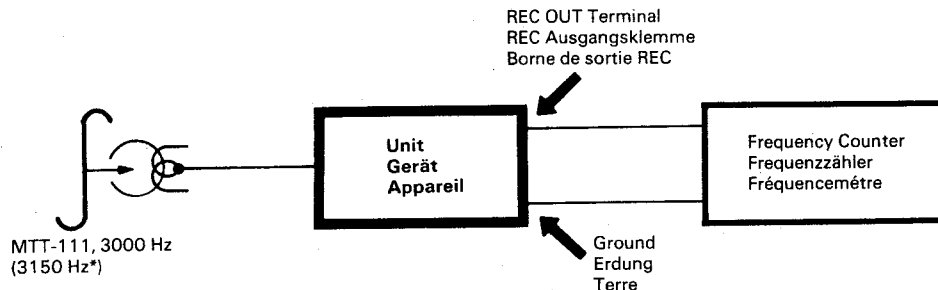

Adjustment: Warm up the unit for approximately 20 minutes; then playback test tape MTT-111, 3,000 Hz (3,150 Hz*) and measure the speed deviation with a frequency counter. If required, adjust the semi-variable resistor on the motor for a reading of 3,000 Hz $\pm \frac{60}{30}$ Hz (3,150 Hz). Carry out the measurement at the middle of the tape.

Einstellung: Das Gerät für etwa 20 Minuten aufwärmen. Danach das Prüfband MTT-111 3.000 Hz (3.150 Hz*) abspielen und die Geschwindigkeitsabweichung mit Hilfe des Frequenzzählers messen. Wenn erforderlich, den Regelwiderstand am Motor auf eine Anzeige von 3.000 $\pm \frac{60}{30}$ Hz (3.150 Hz*) einstellen. Die Messung in der Mitte des Bandes vornehmen.

Reglage proprement dit: Laisser chauffer l'appareil pendant environ 20 minutes; lire une bande de test MTT-111, 3.000 Hz (3.150 Hz*) et mesurer l'écart de vitesse avec le fréquencesmètre. Au besoin, procéder à un réglage de la résistance semi-ajustable du moteur pour obtenir une indication de 3.000 Hz $\pm \frac{60}{30}$ Hz (3.150 Hz). Effectuer cette mesure en milieu de bande.

2. Head azimuth adjustment

Setting: Playback mode
Connection:

2. Tonkopf-Azimuteinstellung

Betriebsart: Wiedergabe
Anschlüsse:

2. Réglage d'azimutal de tête magnétique
Réglage préliminaire: Mode de lecture

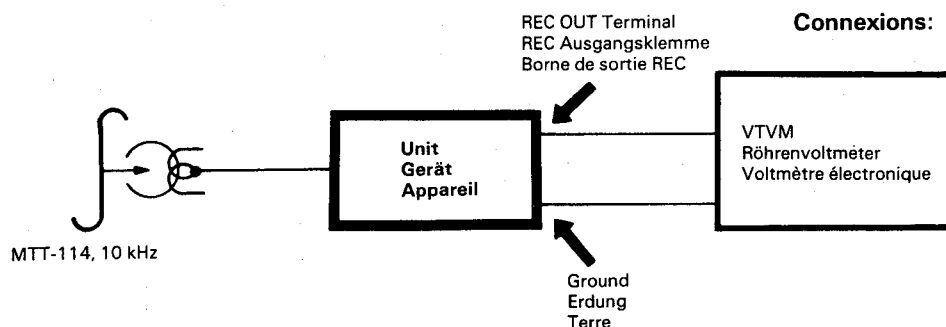

Connexions:

Adjustment: Playback a test tape (MTT-114, 10 kHz) and adjust the azimuth adjustment screw for maximum output.
When the maximum values of both channels are different, tune to the maximum value of the L channel. In this case, the difference between the maximum values of both channels should be within 2 dB.

Einstellung: Das Prüfband MTT-114 (10 kHz) abspielen und die Azimuteinstellschraube auf maximalen Ausgangspegel einstellen.
Wenn der Maximum-Wert für beide Kanäle unterschiedlich ist, den Maximum-Wert für den linken Kanal einstellen. In diesem Fall sollte der Unterschied zwischen den Maximum-Werten beider Kanäle innerhalb 2 dB liegen.

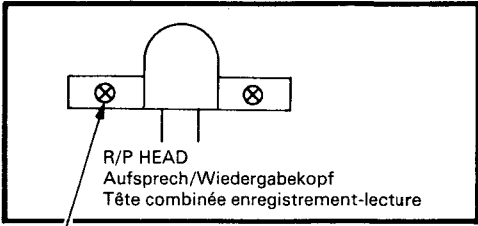

Adjustment screw
Einstellschraube
Vis de réglage

Réglage proprement dit: Lire une bande de test (MTT-114, 10 kHz) et agir sur la vis de réglage d'azimut pour obtenir un niveau de sortie maximum.
Si les valeurs maximum des deux canaux sont différentes, accorder sur la valeur maximum du canal gauche. Dans ce cas, la différence entre les valeurs maximum des deux canaux doit être inférieure à 2 dB.

3. Playback output and level indicator adjustment
Setting: Playback mode
Connection:

3. Einstellung des Wiedergabe-Ausgangspegels und der Pegelanzeige
Betriebsart: Wiedergabe
Anschlüsse:

3. Réglage de niveau de sortie de lecture et de décibelmètre
Réglage préliminaire: Mode de lecture
Connexions:

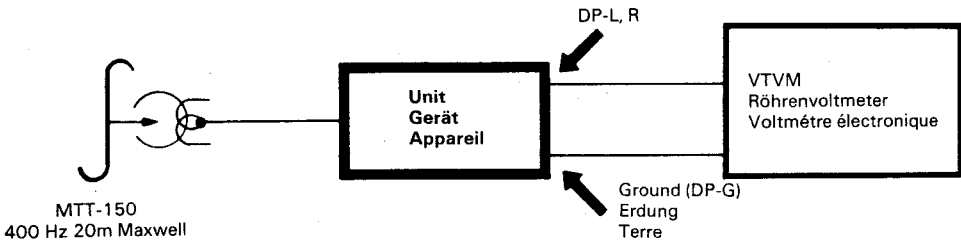

Apply Dolby calibration tape signal to AUX jacks and confirm that the 0 dB LED of the level meter turns ON/OFF when the calibration signal level is changed from -5 ~ -1 dB.

Den AUX-Buchsen das Dolby-Signal des Kalibrierbandes zuführen und überprüfen, ob die 0 dB LED des Pegelmessers ein/ausleuchtet (ON/OFF), wenn der Kalibrierungssignalpegel von -5 ~ -1 dB geändert wird.

Appliquer un signal d'étalonnage Dolby aux prises AUX et s'assurer que la LED 0 dB de l'indicateur de niveau s'allume puis s'éteint lorsque le niveau de signal d'étalonnage passe de -5 ~ -1 dB.

Adjustment: Playback a Dolby calibration tape (MTT-150, 400 Hz 20 m Maxwell) and adjust RT902L, R so that the voltage of DP-L, R becomes 0.58V ± 0.5 dB.

Einstellung: Ein Dolby-Kalibrierband MTT-150 (400 Hz, 20 m Maxwell) abspielen und RT902L/R so einstellen, daß die Spannung an DP-L, R 0,58V ± 0,5 dB beträgt.

Réglage proprement dit: Lire une bande d'étalonnage de Dolby (MTT-150, 400 Hz 20m Maxwell) et régler RT902L, R pour que la tension présente à DP-L, R soit égale à 0,58V ± 0,5 dB.

4. Dolby NR Check
Setting: Playback mode
Connection:

4. Dolby-NR-Prüfung
Betriebsart: Aufnahme
Anschlüsse:

4. Contrôle de fonctionne du réducteur de souffle Dolby
Réglage préliminaire: Mode d'enregistrement
Connexions:

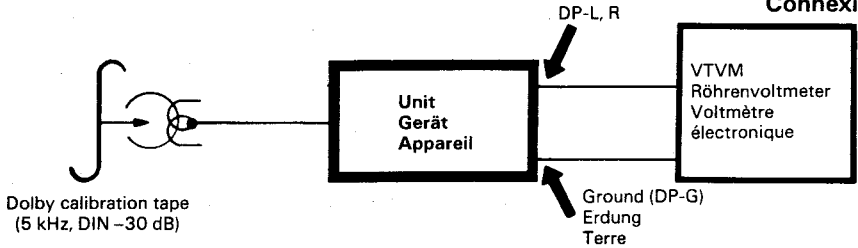

Check: Playback Dolby calibration tape (5 kHz, DIN -30 dB) and confirm that the difference are more than 8 dB or 12 dB between Dolby OFF and B positions and between Dolby OFF and C positions respectively. (Measure with a low pass filter of 30 kHz - 100 kHz.)

Prüfung: Dolby-Kalibrierungsband (5 kHz, DIN -30 dB) wiedergeben und überprüfen, ob der Unterschied zwischen der DOLBY OFF - und B-Stellung sowie zwischen DOLBY OFF - und C-Stellung jeweils mehr als 8 dB oder 12 dB beträgt. (Mit Niederfrequenzsieb-kette von 30 kHz - 100 kHz messen.)

Contrôle: Reproduire la bande d'étalonnage Dolby (5 kHz, DIN -30 dB) et s'assurer que les différences sont supérieures à 8 dB et 12 dB entre les positions Dolby OFF et B et entre les positions Dolby OFF et C, respectivement. (Mesurer avec un filtre passe-bas de 30 kHz - 100 kHz.)

5. Bias current adjustment
Setting: Recording mode
Connection:

5. Einstellung des Vormagnetisierungsstromes
Betriebsart: Aufnahme
Anschlüsse:

5. Réglage de courant de pré-magnétisation
Réglage préliminaire: Mode d'enregistrement
Connexions:

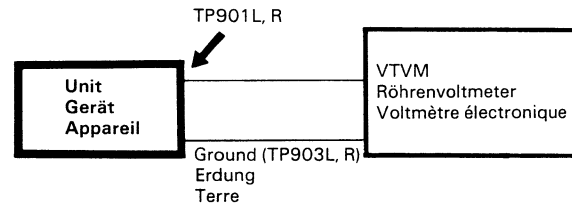

Adjustment: Set the record mode. Adjust RT901L, R so that the bias voltage of 8 mV is applied to the both ends of METAL position.

Einstellung: Das Gerät auf Aufnahme schalten. RT901L/R so einstellen, daß die Vormagnetisierungsspannung an beiden Ende des 8 mV bei auf Position METAL gestelltem Bandsortenwähler beträgt.

Réglage proprement dit: Régler en mode d'enregistrement. Ajuster RT-901L, R pour que la tension de pré-magnétisation de 8 mV soit appliquée aux deux extrémités de la position METAL.

6. Record/playback output, frequency characteristics adjustment
Setting: Recording/playback mode
Connection:

6. Einstellung des Aufnahme/Wiedergabe-Ausganges und des Frequenzganges
Betriebsart: Aufnahme/Wiedergabe
Anschlüsse:

6. Réglage de niveau de sortie d'enregistrement et de lecture et des caractéristiques de fréquence
Réglage préliminaire: Mode d'enregistrement/de lecture
Connexions:

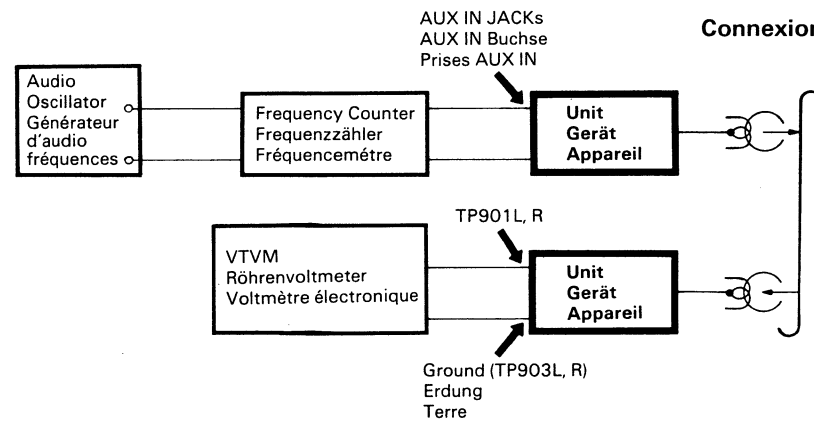

Step Bediebschritt Etape	Tape Band Bande	TAPE switch TAPE-Schalter Interrupteur TAPE	Recording level Aufnahmepegel Niveau d'enregistrement			Playback level Wiedergabepegel Niveau de lecture		Adjustment procedure Abstimmverfahren Processus de réglage
			Frequency (Hz) Frequenz (Hz) Fréquence (Hz)	Level Pegel Niveau	Adjustment Abstimmung Réglage	Level Pegel Niveau	Adjustment Abstimmung Réglage	
1	Metal tape Reineisenband Bande métal	METAL	400	0 VU-10 dB	Attenuator Abschwächer Affaibilisseur	Within ± 1 dB Innerhalb ± 1 dB A ± 1 dB près	RT903L, R	
2	Metal tape Reineisenband Bande métal	METAL	400/10K	0 VU-25 dB	Attenuator Abschwächer Affaibilisseur	Within ± 1.5 dB Innerhalb ± 1,5 dB A ± 1,5 dB près	RT901L, R	
3	Metal tape Reineisenband Bande métal	METAL	400	0 VU-10 dB	Attenuator Abschwächer Affaibilisseur	Within ± 1 dB Innerhalb ± 1 dB A ± 1 dB près	Check Prüfen Contrôle	If misaligned, readjust from step 1. Bei falscher Ausrichtung von Bedienungsschritt 1 neu abstimmen. Si l'alignement est incorrect, recommencer à partir de l'étape 1.
4	Normal tape Normal-Band Bande normale	NOR	400/10K	0 VU-25 dB	Attenuator Abschwächer Affaibilisseur	Within ± 2 dB Innerhalb ± 2 dB A ± 2 dB près	Check Prüfen Contrôle	
5	Chromium tape Chromband Bande au chrome	CrO ₂	400/10K	0 VU-25 dB	Attenuator Abschwächer Affaibilisseur	Within ± 2 dB Innerhalb ± 2 dB A ± 2 dB près	Check Prüfen Contrôle	

Inspection of mechanism · Inspektion des mechanismus · Inspection du mécanismes

Check Item Prüfpunkt Pièce à contrôler	Reference Value Bezugswert Valeur de référence	Remarks Bemerkungen Remarques	
1 Pressure of Pressure roller Kraft der Andruckrolle Pression du galet-presseur	300 to 350 gr 300 bis 350 g 300 à 350 gr	Measure in playback mode In der Wiedergabe-Betriebsart messen Mesurer en mode de lecture	
2 Tape drive force Bandantriebskraft Force de traction de la bande	Above 120 gr Über 120 g Au-dessus de 120 gr	Measure in playback mode In der Wiedergabe-Betriebsart messen Mesurer en mode de lecture.	
3 Torque Drehmoment Couple	Take-up Aufwickelteller Réception	40 to 65 gr-cm 40 bis 65 g-cm 40 à 65 cm-gr	Measure in playback mode In der Wiedergabe-Betriebsart messen Mesurer en mode de lecture
	Fast forward Schnellvorlauf Défilement rapide	75 to 110 gr-cm 75 bis 110 g-cm 75 à 110 cm-gr	Measure in fast forward mode In der Schnellvorlauf-Betriebsart messen Mesurer en mode de défilement rapide
	Rewind Rücklauf Réembobinage	75 to 110 gr-cm 75 bis 110 g-cm 75 à 110 cm-gr	Measure in rewind mode In der Rücklauf-Betriebsart messen Mesurer en mode de réembobinage
4 Back-tension Spannmoment Tension arrière	Take-up side Aufwickelteller Côte réception	2.5 to 4 gr-cm 2,5 bis 4 g-cm 2,5 à 4 cm-gr	With counter Mit Zählwerk Avec le compteur
	Supply side Vorratsteller Côté débit	1.7 to 5 gr-cm 1,7 bis 5 g-cm 1,7 à 5 cm-gr	Without counter Ohne Zählwerk Sans le compteur
5 Brake force Bremsmoment Force de freinage	50 to 100 gr-cm 50 bis 100 g-cm 50 à 100 cm-gr	-	

LUBRICATION · SCHMIERUNG · LUBRIFICATION

Lubricate one or two drops of oil to rotating point or lubricate grease to sliding point. Lubricate the respective parts listed below once every 1000 hours or once a year under normal conditions of use. Avoid oiling them excessively, or rotation may become irregular because of oil splashes.

Alle drehenden Teile mit einem oder zwei Tropfen Öl und alle Gleitteile mit Fett schmieren. Die nachfolgend aufgeführten Teile sind alle 1.000 Betriebsstunden oder einmal jährlich unter normalen Betriebsbedingungen zu schmieren. Niemals zu viel Öl auftragen, da es anderenfalls zu einer unregelmäßigen Bandgeschwindigkeit kommen könnte.

Lubrifier en appliquant une ou deux gouttes d'huile aux points de rotation ou mettre de la graisse aux points de coulissement. Lubrifier les pièces qui sont mentionnées ci-dessous toutes les 1000 heures de service ou tous les ans pour des conditions d'utilisation normales. Eviter de trop mettre d'huile sinon la rotation risque de devenir irrégulière et des éclaboussures d'huile sur d'autres pièces sont à craindre.

	Lubrication Schmierung Lubrification	Oil or Grease Öl oder Fett Huile ou graisse
Rotary section Drehende Teile Section rotative	Metal and metal Metall und Metall Métal contre métal	Pan motor oil (10W-40) PAN-Motoröl (10W/40) Huile Pan Motor (10W-40)
	Mold and metal Kunststoff und Metall Pièce moulée contre métal	Sonic slider oil (# 1600) SONIC-Schmieröl (Nr. 1600) Huile pour curseur Sonic (# 1600)
Sliding section Gleitteile Pièce coulissante	Metal and metal Metall und Metall Métal contre métal	Hitasol (MO-138) HITASOL (MO-138) Hitasol (MO-138)
	Mold and mold Kunststoff und Kunststoff Pièce moulée contre pièce moulée	Froil (GB-TS-1)
	Mold and metal Kunststoff und Metall Pièce moulée contre métal	FROIL (GB-TS-1) Froil (GB-TS-1)

PRINTED WIRING BOARD · PRINTPLATTEN · PLAN DE BASE

TUNER SECTION (for U.S.A., Canada, Asia & Latin American countries, etc.)
 TUNER-SEKTION (für USA, Kanada, Asien, Lateinamerika und so weiter)
 SECTION TUNER (pour Etats-Unis, Canada, l'Asie, les Pays d'Amérique Latine, etc)

[■ : +B, □ : -B, ■ : Earth, □ : Other]

* : Axial lead cylindrical ceramic capacitor
 * : Zylindrischer Keramik Kondensator mit axialer Suleitung
 * : Condensateur céramique cylindrique à conducteur axial

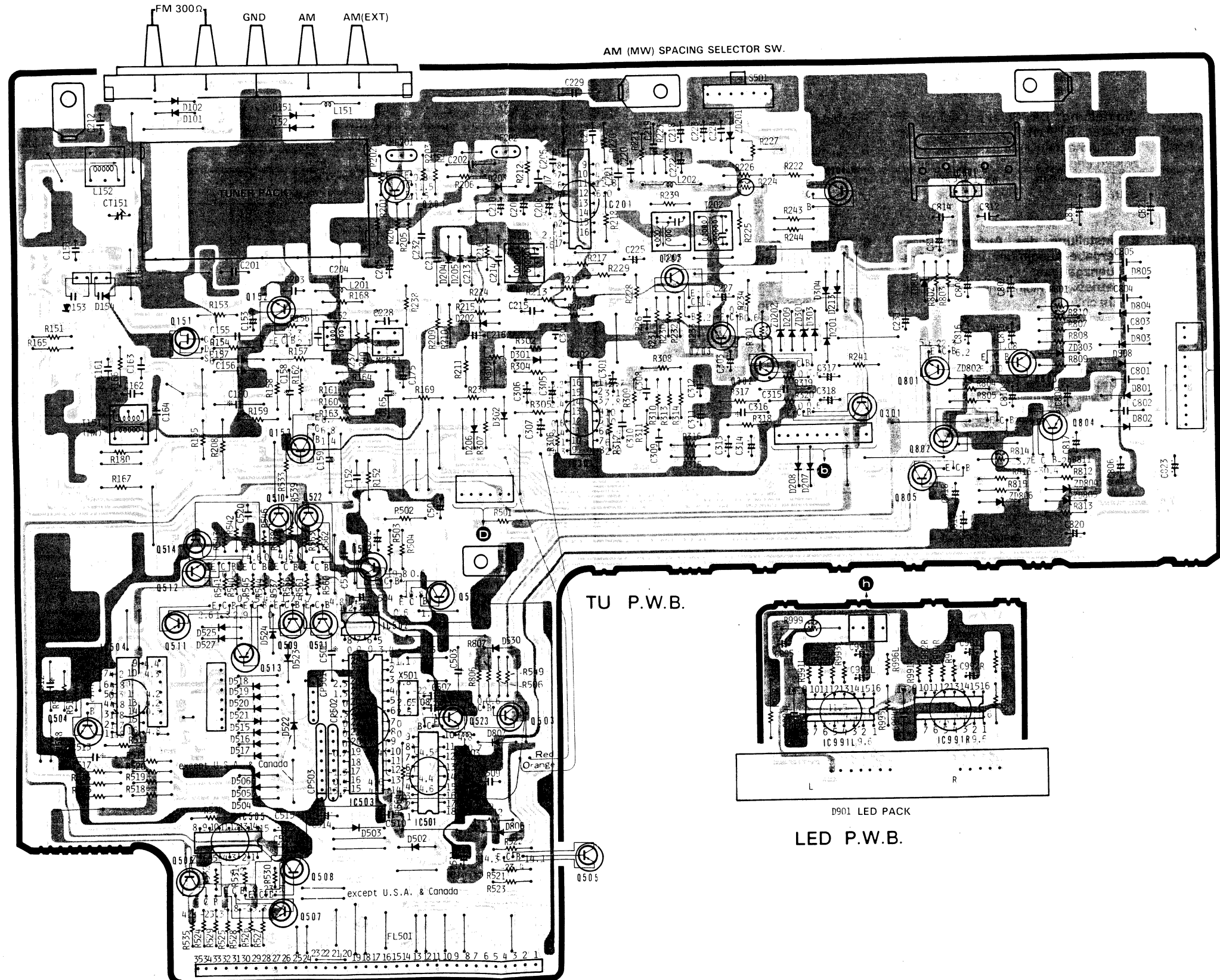

TU P.W.B.

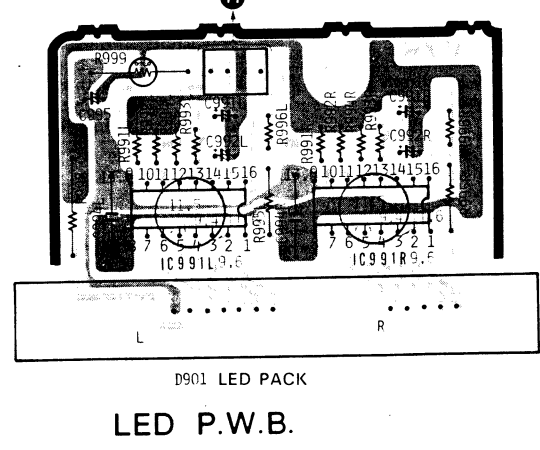

CIRCUIT DIAGRAM · SCHALTPLAN · PLAN DE CIRCUIT

TUNER SECTION (for U.S.A., Canada, Asia & Latin American countries, etc.)
 TUNER-SEKTION (für USA, Kanada, Asien, Lateinamerika und so weiter)
 SECTION TUNER (pour Etats-Unis, Canada, l'Asie, les Pays d'Amérique Latine, etc)

- * : Axial lead cylindrical ceramic capacitor
- * : Zylindrischer Keramikkondensator mit axialer Suleitung
- * : Condensateur céramique cylindrique à conducteur axial

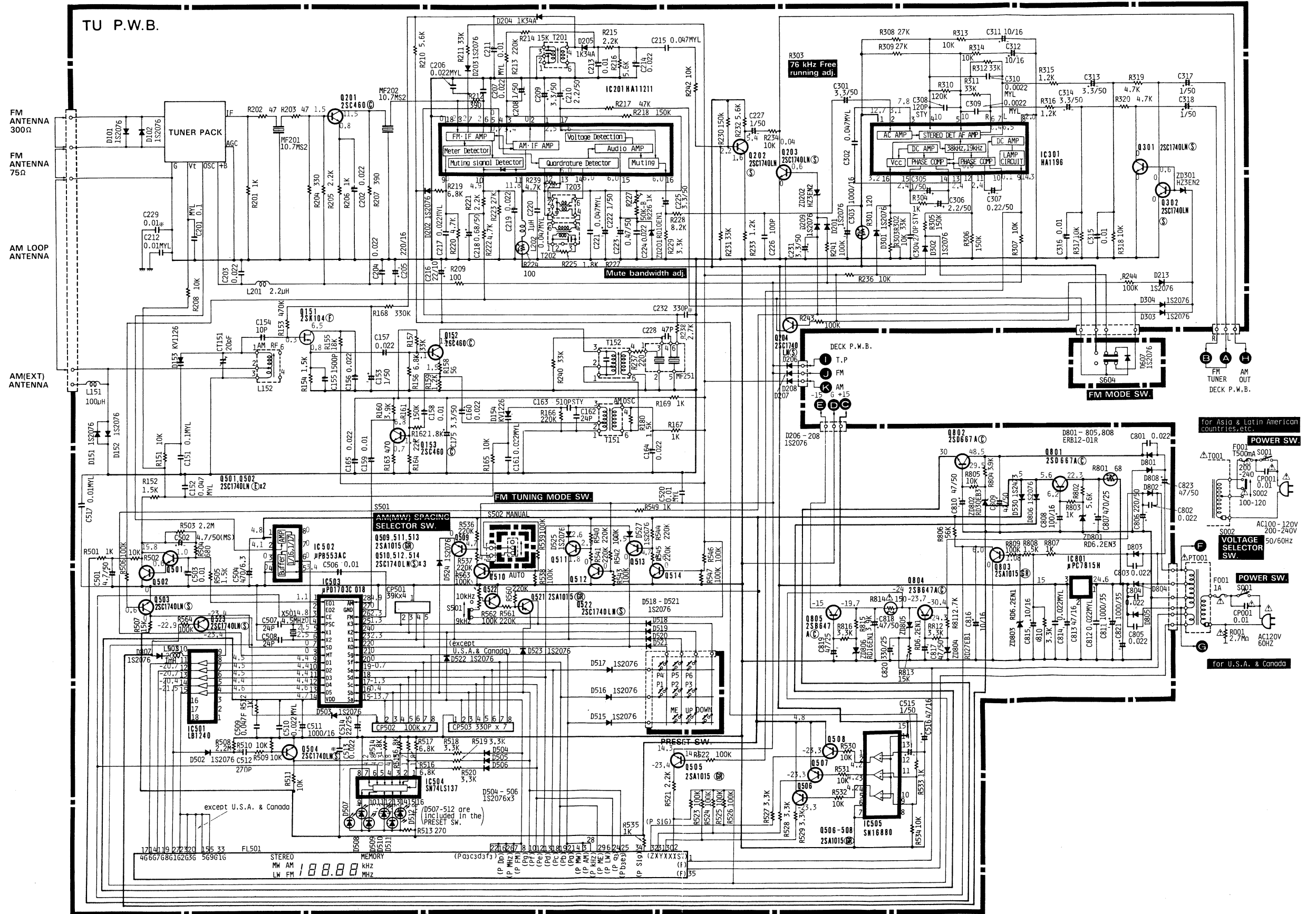

CIRCUIT DIAGRAM · SCHALTPLAN · PLAN DE CIRCUIT **TUNER SECTION (for U.K., Australia, Switzerland, Sweden & W. Germany)**
TUNER SEKTION (für England, Australien, die Schweiz, Schweden und West-Deutschland)
SECTION TUNER (pour le Royaume-Uni, l'Australie, la Suède, et l'Allemagne de l'Ouest)

- * : Axial lead cylindrical ceramic capacitor
- * : Zylindrischer Keramikcondensator mit axialer Suleitung
- * : Condensateur céramique cylindrique à conducteur axial

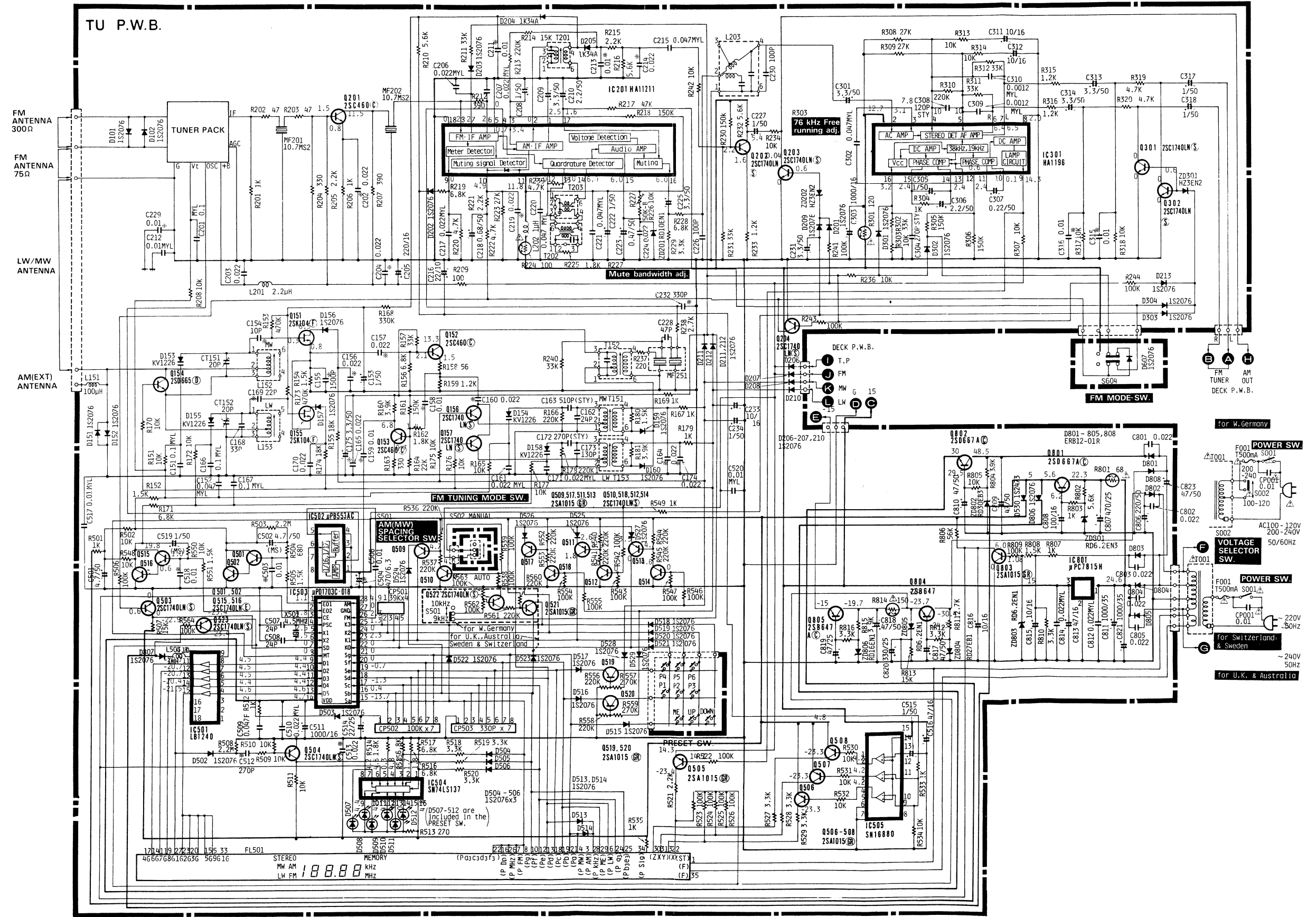

PRINTED WIRING BOARD · PRINTPLATTEN · PLAN DE BASE

CONTROL AMP & DECK SECTION · VERSTÄRKER- UND DECK-SEKTION · SECTION AMPLIFICATEUR ET MAGNETOPHONE

[■ : +B, □ : -B, ■ : Earth, ○ : Other]

* : Axial lead cylindrical ceramic capacitor
 * : Zylindrischer Keramikkondensator mit axialer Suleitung
 * : Condensateur céramique cylindrique à conducteur axial

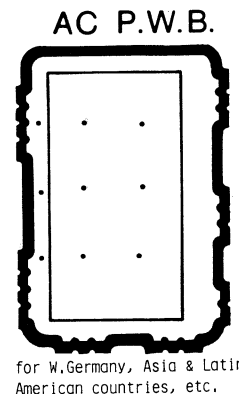
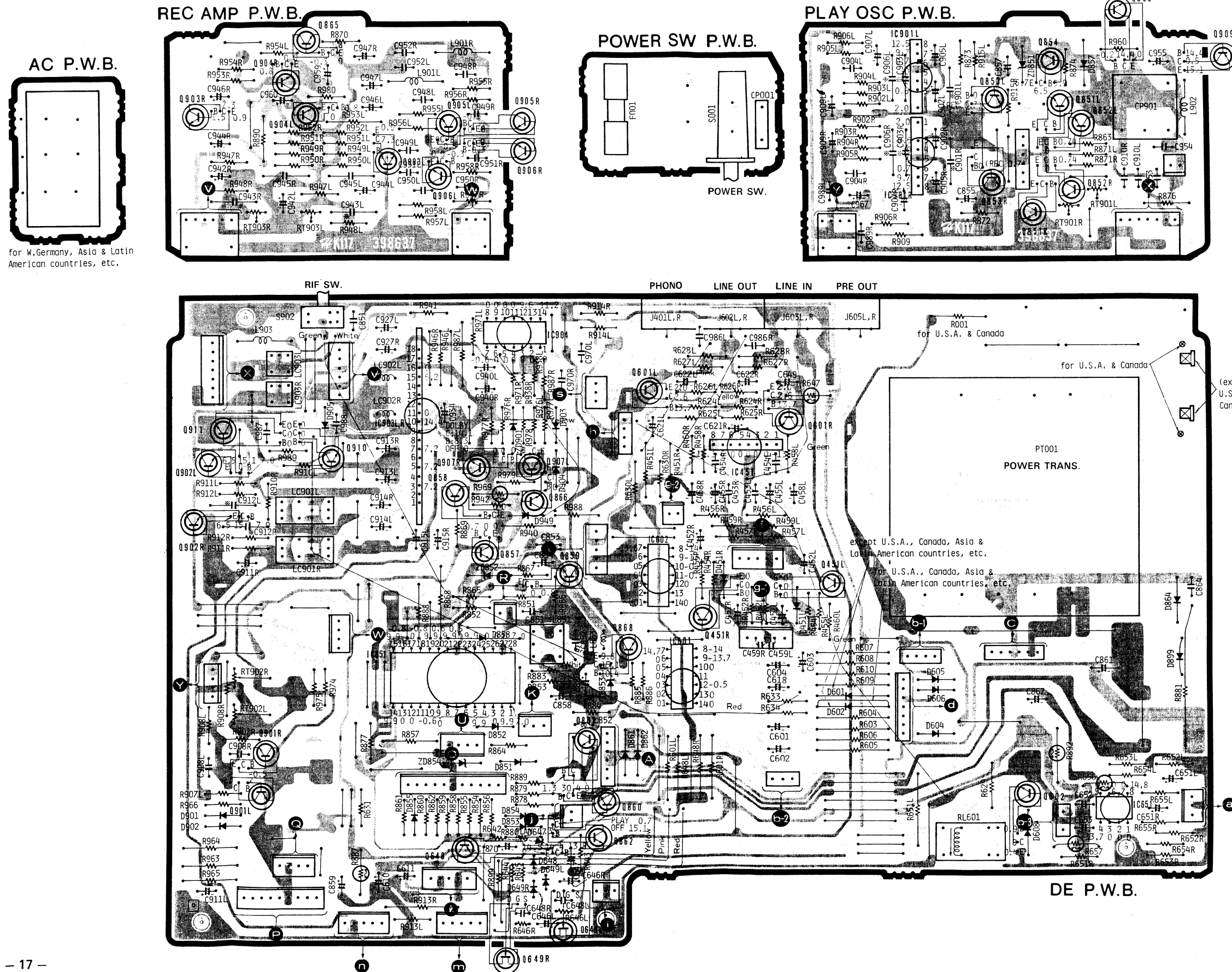

HA11211	2SA825, 2SA1015 2SA992, 2SB647A 2SC1845, 2SC460 2SD667A, 2SD468 2SC1740LN
HA1196, IR2E01 SN74LS137	2SA673A
μPB553AC μPC4557DX	2SD985
μPD1703C-018	(except U.S.A. & Canada)
CX770, SN16880 TC4066BP	1S2473, HZ-3 1S2076
LB1240	RD3.0EN1, RD16EN1 RD6.2EN3, RD10EN1 RD27EB1, RD30EB1
M5214L, M5219L	ERB12-01R
BA340, BA335	1K34A
μPC7815	KV1226
μPD554C-081	SLC-22UR(L ED)
2SK104, 2SK246	

CIRCUIT DIAGRAM · SCHALTPLAN · PLAN DE CIRCUIT
CONTROL AMP & DECK SECTION · VERSTÄRKER- UND DECK-SEKTION · SECTION AMPLIFICATEUR ET MAGNETOPHONE

- * : Axial lead cylindrical ceramic capacitor
- * : Zylindrischer Keramikkondensator mit axialer Suleitung
- * : Condensateur céramique cylindrique à conducteur axial

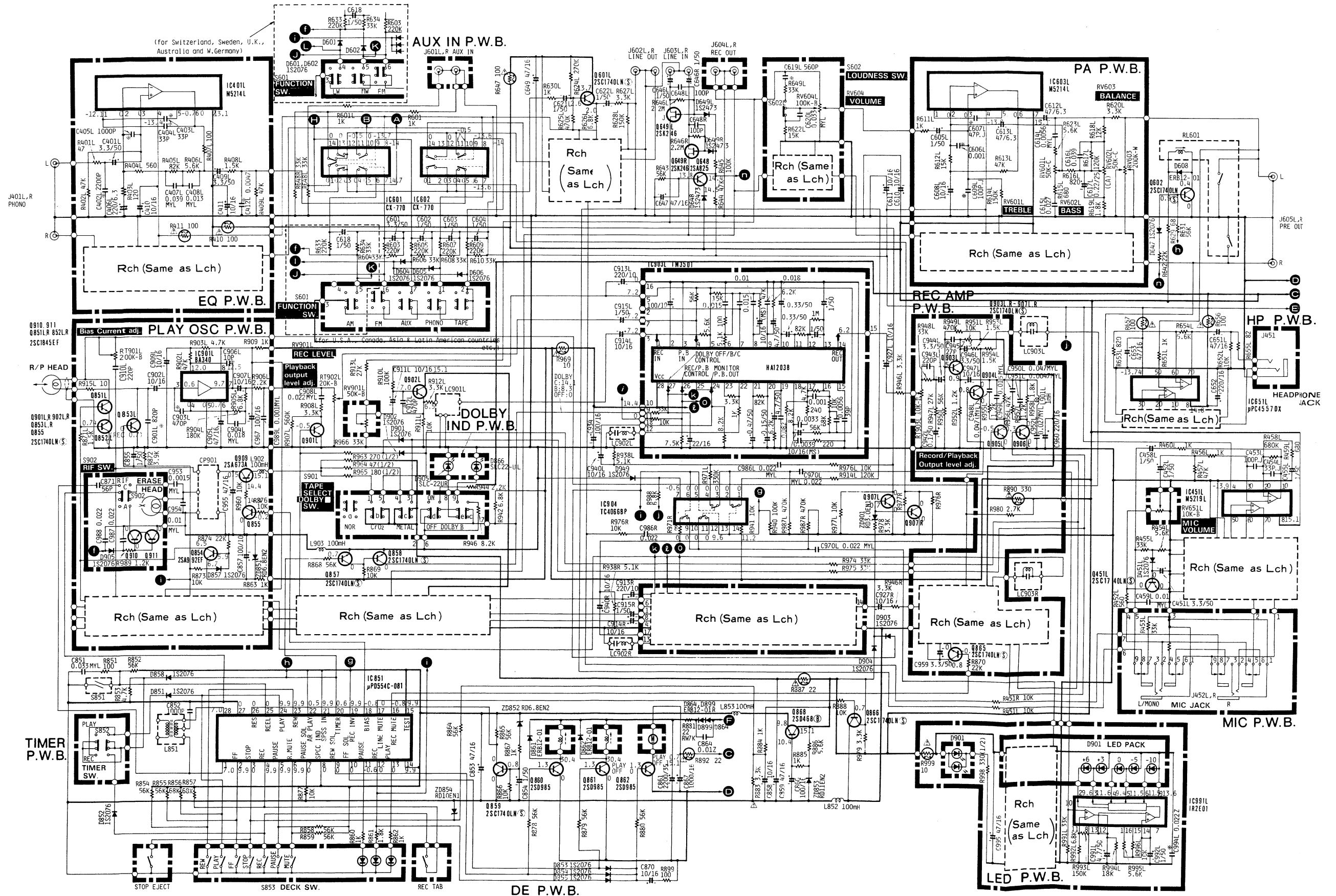

PRINTED WIRING BOARD · PRINTPLATTEN · PLAN DE BASE

[: +B, : -B, : Earth, : Other]

* : Axial lead cylindrical ceramic capacitor
 * : Zylindrischer Keramikcondensator mit axialer Suleitung
 * : Condensateur céramique cylindrique à conducteur axial

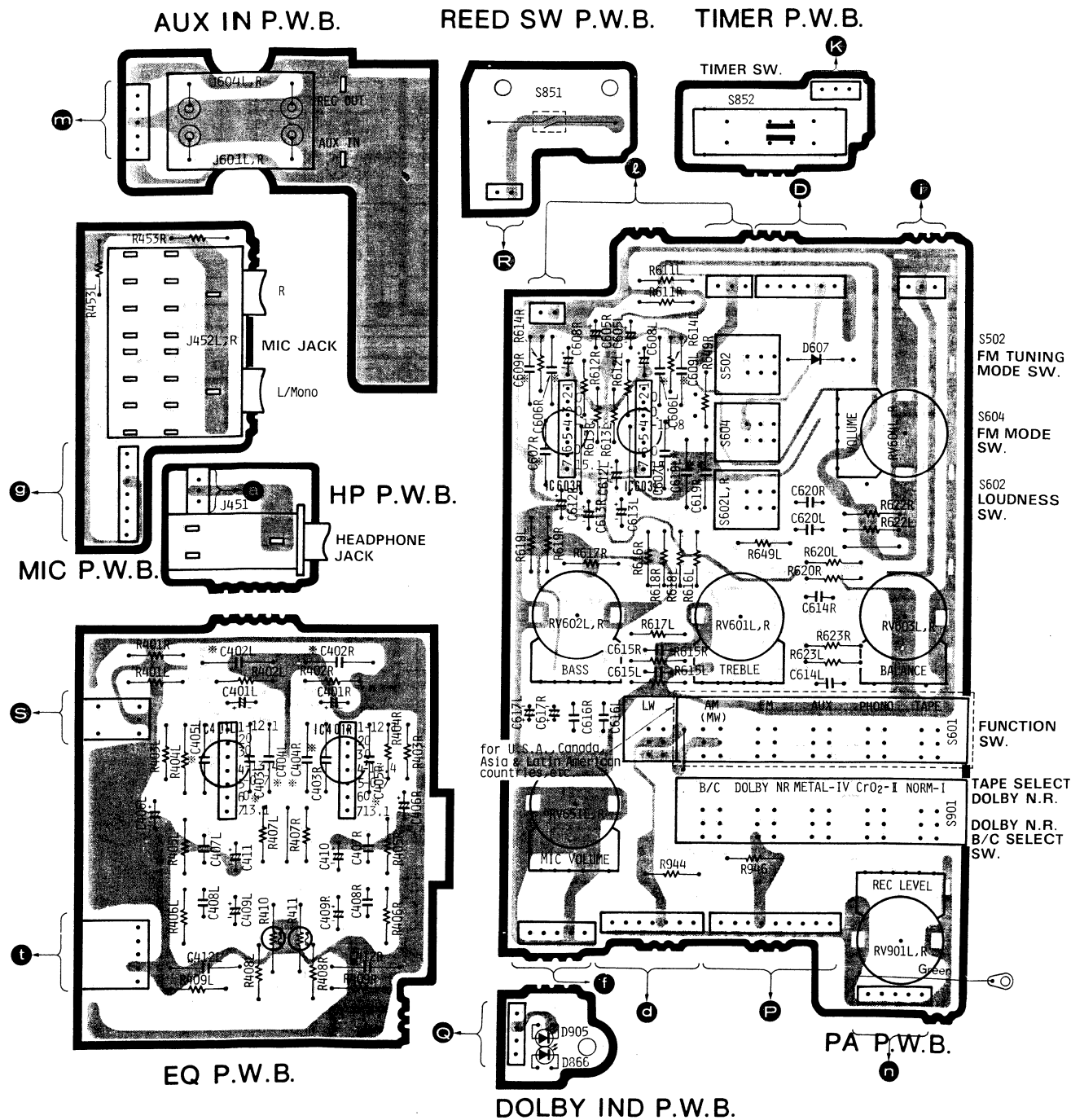

BLOCK DIAGRAM · BLOCK SCHEMA · SCHEMA

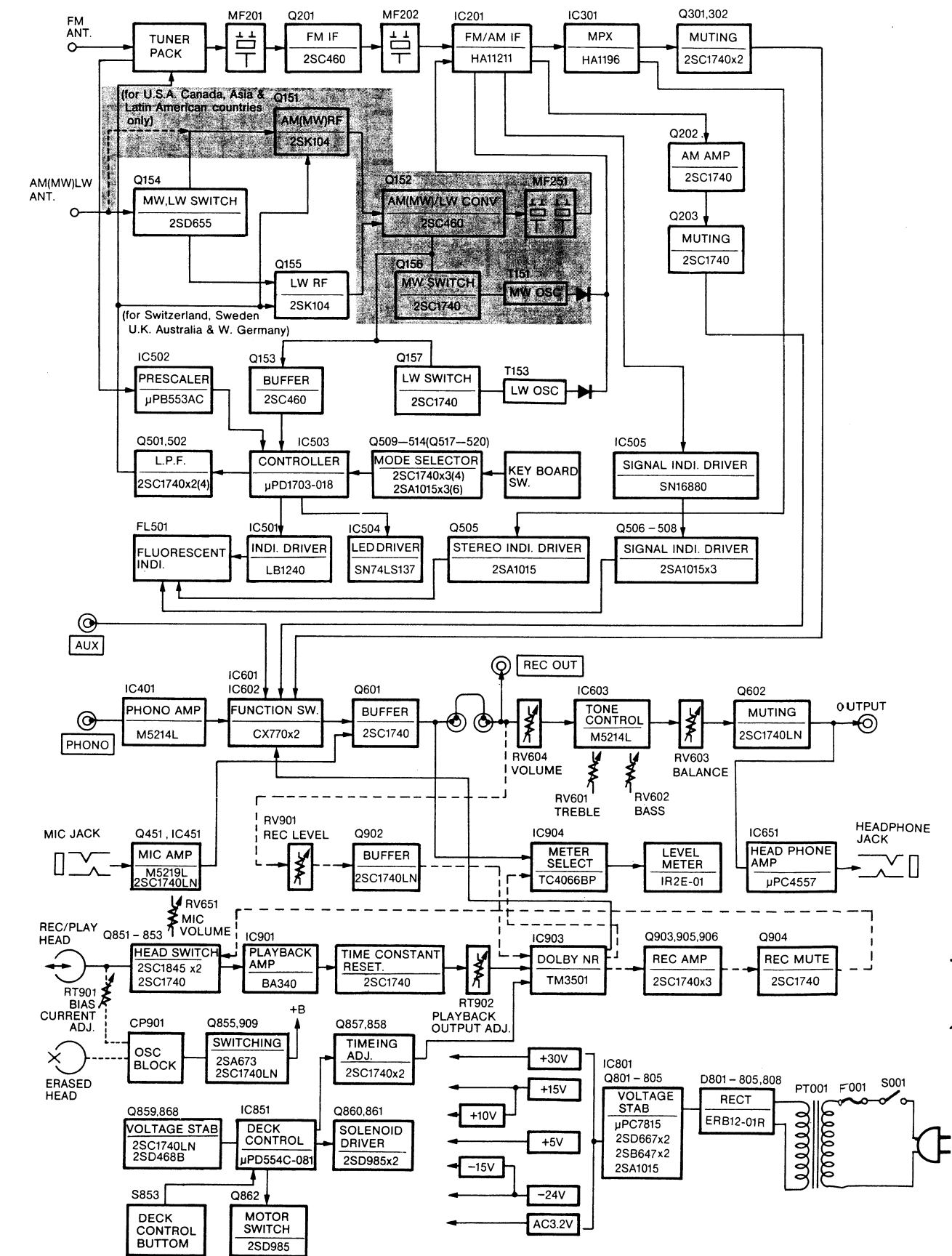

WIRING DIAGRAM · SCHALTPLAN · SCHÉMA DE CÂBLAGE

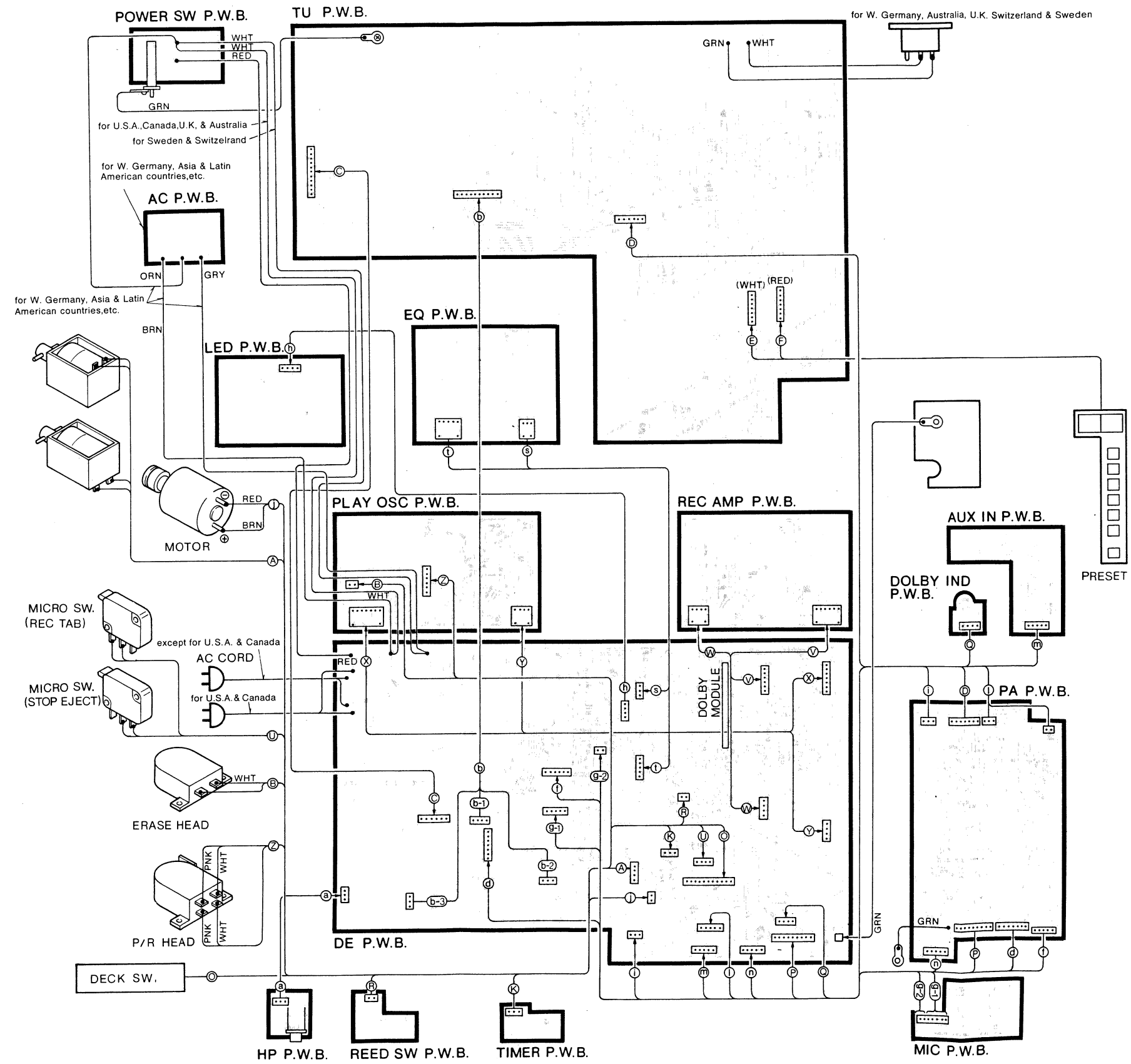

EXPLODED VIEW · EXPLOSIONSANSICHT · VUE EXPLOSÉE (Cassette chassis section: FL-90C)

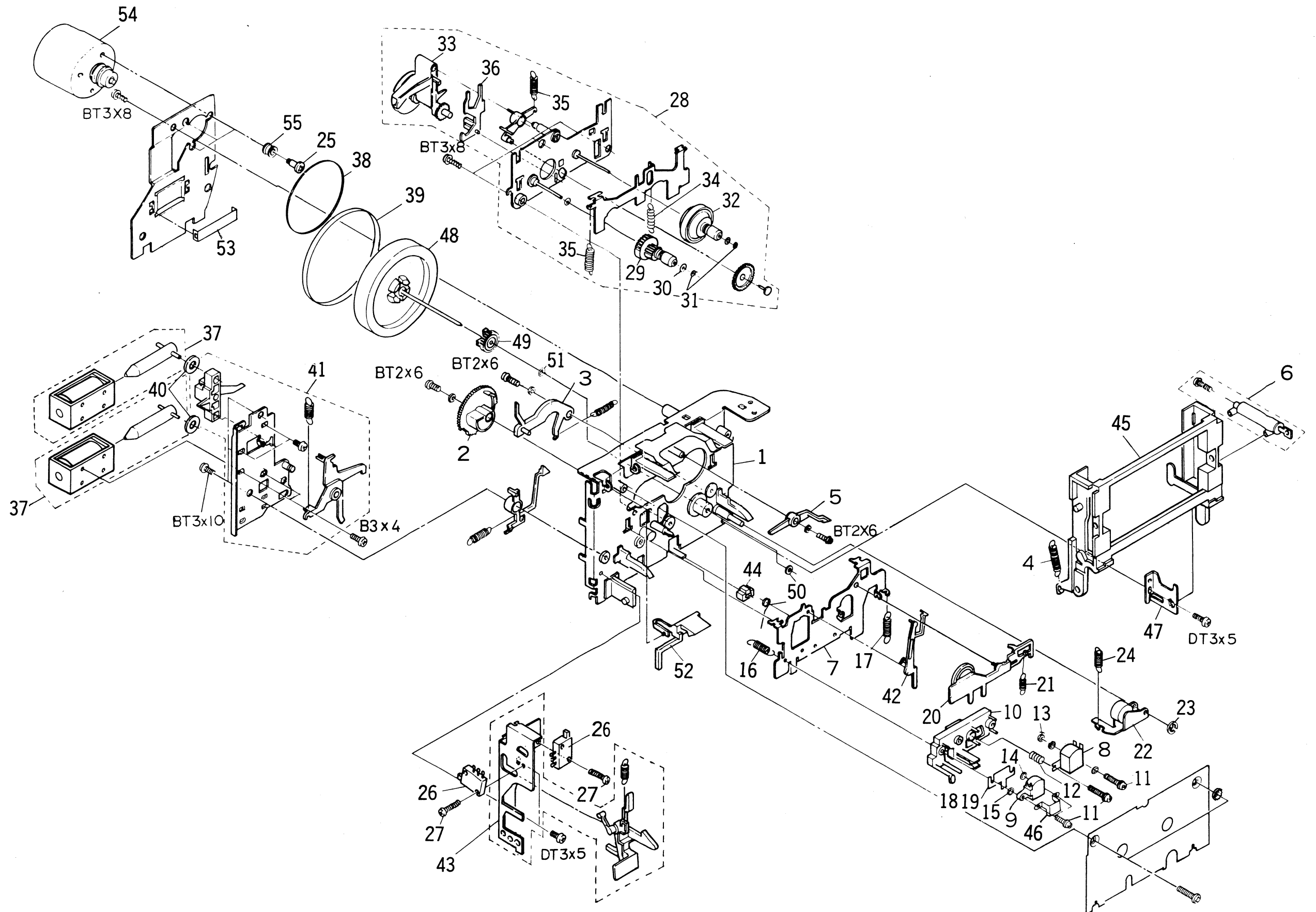

EXPLODED VIEW · EXPLOSIONSANSICHT · VUE EXPLOSÉE (Cabinet section)

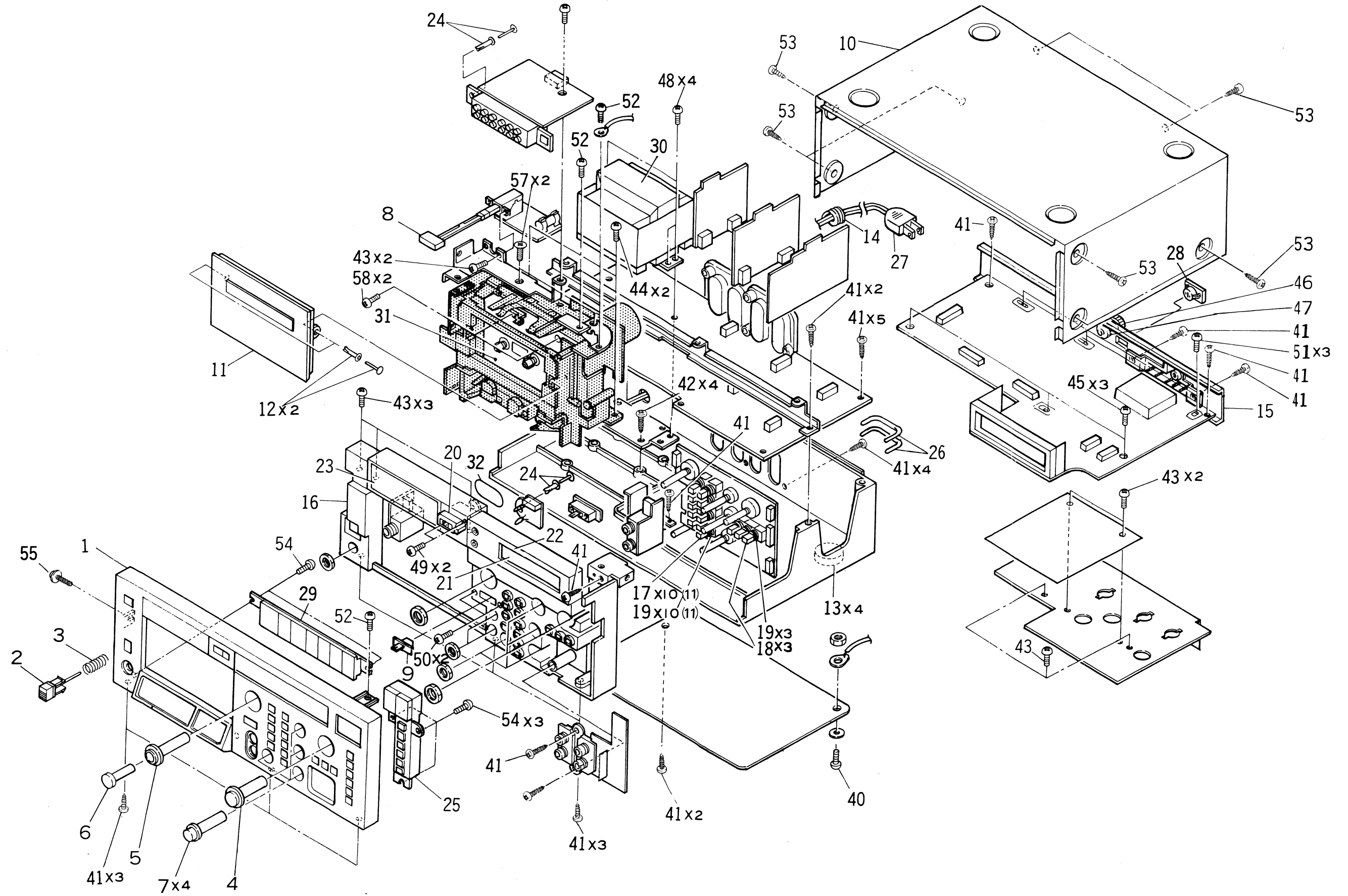

REPLACEMENT PARTS LIST · ERSATZTEILLISTE · TABLEAU DES PIÉCE

ITEM NO.	PART NO.	DESCRIPTION	ITEM NO.	PART NO.	DESCRIPTION
CASSETTE CHASSIS SECTION					
1	3902041	Chassis base holder assembly	3	3362541	Eject spring
2	3949341	Play gear	4	3292952	Knob (27φ)
3	3949301	Play arm	5	3292921	Record knob (out)
4	6301723	Spring for cassette holder	6	3292931	Record knob (in)
5	6761821	Pick up arm	7	3292942	Knob (16φ)
6	6769221	Damper assembly	8	3292981	Push button assembly
7	4446671	Head plate assembly	9	3293011	Timer knob
8	5449021	Record playback head	10	4442841	Cover
9	5445351	Erase head	11	3952422	Cassette door
10	3948275	Head plate	12	3933804	Rivet
11	7775211	Special screw	13	4746471	Foot
12	6321733	Head spring	14	3913003	Bushing (except for US)
13	7771441	Washer - 2 mm φ	15	3715181	Bushing (for US)
14	7771442	Washer - 2 mm φ	16	4443192	Rear plate (for CS, US)
15	7771444	Washer - 2 mm φ	17	4443194	Rear plate (for ZW)
16	6302375	Spring	18	4443195	Rear plate (for BS, SA)
17	6301022	Spring	19	4443196	Rear plate (for EW)
18	7332762	Head spacer	20	4443197	Rear plate (for VK)
19	7332764	Head spacer	21	3952401	Front chassis
20	3949471	Take up idler assembly	22	3293101	FUNCTION button (N) assembly
21	6320578	Spring for take up idler	23	3293102	FUNCTION button (B) assembly
22	7330581	Pressure roller arm assembly	24	3362531	Knob spring
23	7230901	E ring	25	2788591	Tape counter
24	6301361	Spring	26	3953161	Smoke panel
25	7539007	Special screw	27	4443182	Plate
26	5633361	Push switch	28	3901532	Record plate
27	0671310	2.6φ × 10 mm DT screw	29	3924472	Rivet
28	3948499	Reel base assembly	30	2639741	Preset switch
29	6414202	Turntable assembly (Supply)	31	2667391	Plug
30	7778855	Poly slider washer	32	2749471	Power cord (for CS, US)
31	7786745	Polyester washer	33	2748752	Power cord (for EW, VK, ZW)
32	6414213	Turntable assembly (Take up)	34	2749622	Power cord (for SA)
33	3948534	FF/Rewind arm assembly	35	2749582	Power cord (for BS)
34	6301001	Spring	36	2677911	FM-Antenna jack (for VK, BS, SA, ZW)
35	6300596	Spring	37	2639692	Deck switch
36	6761733	Select slider	38	2788551	Bar lock (for cord fixing)
37	5642921	DC solenoid	39	2247844	Power trans (for EW, ZW) (T001)
38	6355193	Belt	40	2247843	Power trans (for VK, BS, SA) (T001)
39	6357301	Flywheel belt	41	2247842	Power trans (for CS, US) (T001)
40	4930394	Spacer	42	4428012	Cassette metal
41	4097767	Solenoid plate assembly	43	4687925	Counter belt
42	6761742	Rewind arm	44	4567432	3φ × 8 DT bind screw
43	7330666	Eject holder	45	4574603	3φ × 10 bind double thread screw
44	6581042	Rubber for record prevention	46	4578302	4φ × 14 bind tapping screw
45	6768333	Cassette holder	47	4567441	3φ × 6 DT bind screw
46	6990651	Insulation plate for head	48	4577836	3φ × 12 bind tapping flat screw
47	4434573	Cassette holder support	49	4567451	3φ × 6 DT bind screw
48	6373751	Flywheel assembly	50	4575661	Earth screw
49	6430932	Flywheel gear	51	4408861	Washer
50	7787566	Poly slider washer	52	4567422	4φ × 8 DT bind screw
51	7772623	Spring	53	8691106	2φ × 6 bind tapping screw
52	6761815	Record prevention arm	54	0741306	2.6φ × 6 bind screw
53	6534162	Flywheel support spring	55	4575962	3φ × 8 DT screw with washer
54	5576765	DC motor assembly	56	4567411	3φ × 6 DT bind screw
55	6589591	Rubber plate	57	4784106	3φ × 10 bind tapping screw
CABINET SECTION					
1	3248452	Front panel assembly (for EW, CS, US)	58	4578972	3φ BT screw
	3248453	Front panel assembly (for VK, BS, SA, ZW)	59	4568812	3φ × 8 DT flat screw
2	3292373	Eject button	60	4578296	2.6φ × 12 DT bind screw

SYMBOL NO.	PART NO.	DESCRIPTION	SYMBOL NO.	PART NO.	DESCRIPTION
CAPACITORS					
for TU P.W.B.					
C151	D276011	Mylar, film	C229	0240106	Cylindrical ceramic
C152	0275015	Mylar, film	C230	0248724	Ceramic, discal
C153	0252811	Electrolytic			(for VK, BS, SA, ZW)
C154	0230062	Cylindrical ceramic	C231	0252813	Electrolytic
C155	0240101	Cylindrical ceramic	C232	0240006	Cylindrical ceramic
C156	0240108	Cylindrical ceramic	C233	0252521	Electrolytic
C157	0240108	Cylindrical ceramic			(for VK, BS, SA, ZW)
C158	0240106	Cylindrical ceramic	C234	0252811	Electrolytic
C159	0240106	Cylindrical ceramic			(for VK, BS, SA, ZW)
C160	0240108	Cylindrical ceramic	C301	0252813	Electrolytic
C161	1275213	Mylar, film	C302	1275215	Mylar, film
C162	0246449	Ceramic, discal	C303	0252541	Electrolytic
C163	0228478	Styrol	C304	0228321	Styrol
C164	0240108	Cylindrical ceramic	C305	0252811	Electrolytic
C165	0240108	Cylindrical ceramic	C306	0252812	Electrolytic
C166	0276011	Mylar, film	C307	0252873	Electrolytic
		(for VK, BS, SA, ZW)	C308	0228313	Styrol
C167	0276011	Mylar, film	C309	1274231	Mylar, film
		(for VK, BS, SA, ZW)			(for VK, BS, SA, ZW)
C168	0246452	Ceramic, discal	C309	1274213	Mylar, film
		(for VK, BS, SA, ZW)			(for EW, CS, US)
C169	0230072	Cylindrical ceramic	C310	1274231	Mylar, film
		(for VK, BS, SA, ZW)			(for VK, BS, SA, ZW)
C170	0240108	Cylindrical ceramic	C310	1274213	Mylar, film
		(for VK, BS, SA, ZW)			(for EW, CS, US)
C171	0275213	Mylar, film	C311	0252521	Electrolytic
		(for VK, BS, SA, ZW)	C312	0252521	Electrolytic
C172	0228321	Styrol	C313	0252813	Electrolytic
		(for VK, BS, SA, ZW)	C314	0252813	Electrolytic
C173	0248687	Ceramic, discal	C315	0240106	Cylindrical ceramic
		(for VK, BS, SA, ZW)	C316	0240106	Cylindrical ceramic
C174	0240108	Cylindrical ceramic	C317	0252811	Electrolytic
		(for VK, BS, SA, ZW)	C318	0252811	Electrolytic
C175	0252813	Electrolytic	C501	0252815	Electrolytic
			C502	0252880	Electrolytic
C201	0276011	Mylar, film	C503	0240106	Cylindrical ceramic
C202	0240108	Cylindrical ceramic	C504	0252235	Electrolytic
C203	0244173	Ceramic, discal	C506	0240106	Cylindrical ceramic
C204	0240108	Cylindrical ceramic	C507	0246449	Ceramic, discal
C205	0252532	Electrolytic	C508	0246449	Ceramic, discal
C206	1275213	Mylar, film	C509	0259890	Special capacitor
C207	1275213	Mylar, film	C510	1275213	Mylar, film
C208	0252811	Electrolytic	C511	0252541	Electrolytic
C209	0252813	Electrolytic	C512	0240005	Cylindrical ceramic
C210	0252812	Electrolytic	C513	0240108	Cylindrical ceramic
C211	0240106	Cylindrical ceramic	C514	0252622	Electrolytic
C212	1275211	Mylar, film	C515	0252811	Electrolytic
C213	0240106	Cylindrical ceramic	C516	0252525	Electrolytic
C214	0240108	Cylindrical ceramic	C517	1275211	Mylar, film
C215	1275215	Mylar, film	C518	0240106	Cylindrical ceramic
C216	0252322	Electrolytic			(for VK, BS, SA, ZW)
C217	1275213	Mylar, film	C519	0252877	Electrolytic
C218	0252876	Electrolytic			(for VK, BS, SA, ZW)
C219	0240108	Cylindrical ceramic	C520	0275211	Mylar, film
C220	1275215	Mylar, film			
C221	0275015	Mylar, film	C801	0244173	Ceramic, discal
C222	0252811	Electrolytic			
C223	0252875	Electrolytic	C805	0244173	Ceramic, discal
C224	0244173	Ceramic, discal	C806	0252832	Electrolytic
C225	0252813	Electrolytic	C807	0252635	Electrolytic
C226	0248724	Ceramic, discal	C808	0252531	Electrolytic
C227	0252811	Electrolytic	C809	0252825	Electrolytic
C228	0248676	Ceramic, discal	C810	0252825	Electrolytic
			C811	0252741	Electrolytic
			C812	1275213	Mylar, film
			C813	0252525	Electrolytic

SYMBOL NO.	PART NO.	DESCRIPTION			SYMBOL NO.	PART NO.	DESCRIPTION		
C814	1275213	Mylar, film	0.022 μ F \pm 5%	50V	C622LR	0252811	Electrolytic	1 μ F	50V
C815	0252521	Electrolytic	10 μ F	16V	C646LR	0252811	Electrolytic	1 μ F	50V
C816	0252521	Electrolytic	10 μ F	16V	C647	0252525	Electrolytic	47 μ F	16V
C817	0252825	Electrolytic	47 μ F	50V	C648LR	0248684	Ceramic, discal	100pF \pm 5%	50V
C818	0252825	Electrolytic	47 μ F	50V	C649	0252525	Electrolytic	47 μ F	16V
C819	0252625	Electrolytic	47 μ F	25V	C651LR	0252525	Electrolytic	47 μ F	16V
C820	0252633	Electrolytic	330 μ F	25V	C652	0252532	Electrolytic	220 μ F	16V
C821	0252741	Electrolytic	1000 μ F	35V	C653	0252525	Electrolytic	47 μ F	16V
C823	0252825	Electrolytic	47 μ F	50V	C851	1275214	Mylar, film	0.033 μ F \pm 5%	50V
C991LR	0252815	Electrolytic	4.7 μ F	50V	C852	0245017	Ceramic, discal	0.01 μ F $\begin{smallmatrix} +50 \\ -20 \end{smallmatrix}$ %	25V
C992LR	0252811	Electrolytic	1 μ F	50V	C853	0252525	Electrolytic	47 μ F	16V
C994LR	0240108	Cylindrical ceramic	0.022 μ F \pm 30%	16V	C854	0252811	Electrolytic	1 μ F	50V
C995	0252525	Electrolytic	47 μ F	16V	C855	0252811	Electrolytic	1 μ F	50V
for PA, P.W.B.									
C401LR	0252813	Electrolytic	3.3 μ F	50V	C857	0252331	Electrolytic	100 μ F	10V
C402LR	0240102	Cylindrical ceramic	2200pF \pm 30%	50V	C858	0252521	Electrolytic	10 μ F	16V
C403LR	0230024	Cylindrical ceramic	33pF \pm 5%	50V	C859	0252525	Electrolytic	47 μ F	16V
C404LR	0230024	Cylindrical ceramic	33pF \pm 5%	50V	C860	0252531	Electrolytic	100 μ F	16V
C405LR	0240020	Cylindrical ceramic	1000pF \pm 20%	50V	C861	0252742	Electrolytic	2200 μ F	35V
C406LR	0252232	Electrolytic	220 μ F	6.3V	C864	0245017	Ceramic, discal	0.01 μ F $\begin{smallmatrix} +50 \\ -20 \end{smallmatrix}$ %	25V
C407LR	1275234	Mylar, film	0.039 μ F \pm 5%	50V	C867	0252541	Electrolytic	1000 μ F	16V
C408LR	1275241	Mylar, film	0.013 μ F \pm 5%	50V	C870	0252521	Electrolytic	10 μ F	16V
C409LR	0252813	Electrolytic	3.3 μ F	50V	C871	0248718	Ceramic, discal	56pF \pm 10%	50V
C410	0252521	Electrolytic	10 μ F	16V	C901LR	0240011	Cylindrical ceramic	820pF \pm 10%	50V
C411	0252521	Electrolytic	10 μ F	16V	C902LR	0252521	Electrolytic	10 μ F	16V
C412LR	0240104	Cylindrical ceramic	4700pF \pm 30%	50V	C903LR	0240008	Cylindrical ceramic	470pF \pm 10%	50V
C605LR	0252811	Electrolytic	1 μ F	50V	C904LR	1275232	Mylar, film	0.018 μ F \pm 5%	50V
C606LR	0240020	Cylindrical ceramic	1000pF \pm 20%	50V	C905LR	0252525	Electrolytic	47 μ F	16V
C607LR	0230028	Cylindrical ceramic	47pF \pm 5%	50V	C906LR	0230012	Cylindrical ceramic	10pF \pm 5%	50V
C608LR	0252521	Electrolytic	10 μ F	16V	C907LR	0252521	Electrolytic	10 μ F	16V
C609LR	0230036	Cylindrical ceramic	100pF \pm 5%	50V	C908LR	0275213	Mylar, film	0.022 μ F \pm 5%	50V
C612LR	0252225	Electrolytic	47 μ F	6.3V	C909LR	0252521	Electrolytic	10 μ F	16V
C613LR	0252225	Electrolytic	47 μ F	6.3V	C910LR	0248692	Ceramic, discal	220pF \pm 5%	50V
C614LR	0274035	Mylar, film	5600pF \pm 10%	50V	C911LR	0252521	Electrolytic	10 μ F	16V
C615LR	0275033	Mylar, film	0.027 μ F \pm 10%	50V	C912LR	0240008	Cylindrical ceramic	470pF \pm 10%	50V
C616LR	0275034	Mylar, film	0.039 μ F \pm 10%	50V	C913LR	0252332	Electrolytic	220 μ F	10V
C617LR	0251923	Electrolytic	0.22 μ F	25V	C914LR	0252521	Electrolytic	10 μ F	16V
C619LR	0240009	Cylindrical ceramic	560pF \pm 10%	50V	C915LR	0252811	Electrolytic	1 μ F	50V
C620LR	0275014	Mylar, film	0.033 μ F \pm 10%	50V	C927LR	0252521	Electrolytic	10 μ F	16V
for DE P.W.B.									
C451LR	0252813	Electrolytic	3.3 μ F	50V	C934	0252531	Electrolytic	100 μ F	16V
C452LR	0252811	Electrolytic	1 μ F	50V	C940LR	0252521	Electrolytic	10 μ F	16V
C453LR	0248684	Ceramic, discal	100pF \pm 5%	50V	C942	0252871	Electrolytic	0.1 μ F	50V
C454LR	0248672	Ceramic, discal	33pF \pm 5%	50V	C943LR	0240004	Cylindrical ceramic	220pF \pm 10%	50V
C455LR	0252811	Electrolytic	1 μ F	50V	C944LR	0252813	Electrolytic	3.3 μ F	50V
C458LR	0252811	Electrolytic	1 μ F	50V	C945LR	0230022	Cylindrical ceramic	27pF \pm 10%	50V
C459LR	0275011	Mylar, film	0.01 μ F \pm 10%	50V	C946LR	0252813	Electrolytic	3.3 μ F	50V
C601	0252813	Electrolytic	3.3 μ F	50V	C947LR	0252521	Electrolytic	10 μ F	16V
C602	0252811	Electrolytic	1 μ F	50V	C948LR	1275215	Mylar, film	0.047 μ F \pm 5%	50V
C603	0252811	Electrolytic	1 μ F	50V	C949LR	0275012	Mylar, film	0.015 μ F \pm 10%	50V
C604	0252811	Electrolytic	1 μ F	50V	C950LR	1275215	Mylar, film	0.047 μ F \pm 5%	50V
C610	0252521	Electrolytic	10 μ F	16V	C951LR	0274015	Mylar, film	4700pF \pm 10%	50V
C611	0252521	Electrolytic	10 μ F	16V	C952LR	0275033	Mylar, film	0.027 μ F \pm 10%	50V
C618	0252811	Electrolytic	1 μ F	50V	C953	0274012	Mylar, film	1500pF \pm 10%	50V
C621LR	0252811	Electrolytic	1 μ F	50V	C954	1275211	Mylar, film	0.01 μ F \pm 5%	50V
					C955	0252525	Electrolytic	47 μ F	16V

HITACHI HTD-G2

SYMBOL NO.	PART NO.	DESCRIPTION			SYMBOL NO.	PART NO.	DESCRIPTION					
C959	0252813	Electrolytic	3.3 μ F	50V	R205	0129609	Carbon film	2.2k Ω	\pm 5%	SRD1/8P		
C960	0252532	Electrolytic	220 μ F	16V	R206	0129601	Carbon film	1k Ω	\pm 5%	SRD1/8P		
C967	0252531	Electrolytic	100 μ F	16V	R207	0129575	Carbon film	390 Ω	\pm 5%	SRD1/8P		
C970LR	1275213	Mylar, film	0.022 μ F \pm 5%	50V	R208	0129631	Carbon film	10k Ω	\pm 5%	SRD1/8P		
C986LR	1275213	Mylar, film	0.022 μ F \pm 5%	50V	R209	0123621	Carbon film	100 Ω	\pm 5%	SRD1/8P		
C987	0209773	Ceramic, discal	0.022 μ F \pm 20%	50V	R210	0129619	Carbon film	5.6k Ω	\pm 5%	SRD1/8P		
C988	0209773	Ceramic, discal	0.022 μ F \pm 20%	50V	R211	0129643	Carbon film	33k Ω	\pm 5%	SRD1/8P		
C989LR	0274011	Mylar, film	1000pF \pm 10%	50V	R212	0129575	Carbon film	390 Ω	\pm 5%	SRD1/8P		
RESISTORS					R213	0129669	Carbon film	220k Ω	\pm 5%	SRD1/8P		
for TU P.W.B.					R214	0129635	Carbon film	15k Ω	\pm 5%	SRD1/8P		
R151	0129631	Carbon film	10k Ω	\pm 5%	SRD1/8P	R215	0129609	Carbon film	2.2k Ω	\pm 5%	SRD1/8P	
R152	0129605	Carbon film	1.5k Ω	\pm 5%	SRD1/8P	R216	0129619	Carbon film	5.6k Ω	\pm 5%	SRD1/8P	
R153	0129677	Carbon film	470k Ω	\pm 5%	SRD1/8P	R217	0129647	Carbon film	47k Ω	\pm 5%	SRD1/8P	
R154	0129605	Carbon film	1.5k Ω	\pm 5%	SRD1/8P	R218	0129665	Carbon film	150k Ω	\pm 5%	SRD1/8P	
R155	0129637	Carbon film	18k Ω	\pm 5%	SRD1/8P	R219	0129621	Carbon film	6.8k Ω	\pm 5%	SRD1/8P	
R156	0129621	Carbon film	6.8k Ω	\pm 5%	SRD1/8P	R220	0129617	Carbon film	4.7k Ω	\pm 5%	SRD1/8P	
R157	0129643	Carbon film	33k Ω	\pm 5%	SRD1/8P	R221	0129609	Carbon film	2.2k Ω	\pm 5%	SRD1/8P	
R158	0129549	Carbon film	56 Ω	\pm 5%	SRD1/8P	R222	0129617	Carbon film	4.7k Ω	\pm 5%	SRD1/8P	
R159	0129603	Carbon film	1.2k Ω	\pm 5%	SRD1/8P	R223	0129641	Carbon film	27k Ω	\pm 5%	SRD1/8P	
R160	0129615	Carbon film	3.9k Ω	\pm 5%	SRD1/8P	Δ R224	0110621	Metal (Fuse-resistor)	100 Ω	\pm 5%	RN1/4B	
R161	0129665	Carbon film	150k Ω	\pm 5%	SRD1/8P	R225	0129607	Carbon film	1.8k Ω	\pm 5%	SRD1/8P	
R162	0129607	Carbon film	1.8k Ω	\pm 5%	SRD1/8P	R226	0129631	Carbon film	10k Ω	\pm 5%	SRD1/8P	
R163	0129577	Carbon film	470 Ω	\pm 5%	SRD1/8P	R226	0129601	Carbon film	1k Ω	\pm 5%	SRD1/8P	
R163	0129573	Carbon film	330 Ω	\pm 5%	SRD1/8P	(for VK, BS, SA, ZW)	R228	0129621	Carbon film	6.8k Ω	\pm 5%	SRD1/8P
R164	0129639	Carbon film	22k Ω	\pm 5%	SRD1/8P	(for EW, CS, US)	R228	0129623	Carbon film	8.2k Ω	\pm 5%	SRD1/8P
R165	0129631	Carbon film	10k Ω	\pm 5%	SRD1/8P	(for VK, BS, SA, ZW)	R229	0129613	Carbon film	3.3k Ω	\pm 5%	SRD1/8P
R166	0129669	Carbon film	220k Ω	\pm 5%	SRD1/8P	R230	0129665	Carbon film	150k Ω	\pm 5%	SRD1/8P	
R167	0129601	Carbon film	1k Ω	\pm 5%	SRD1/8P	R231	0129643	Carbon film	33k Ω	\pm 5%	SRD1/8P	
R168	0129673	Carbon film	330k Ω	\pm 5%	SRD1/8P	R232	0129619	Carbon film	5.6k Ω	\pm 5%	SRD1/8P	
R169	0129601	Carbon film	1k Ω	\pm 5%	SRD1/8P	R233	0129603	Carbon film	1.2k Ω	\pm 5%	SRD1/8P	
R170	0129631	Carbon film	10k Ω	\pm 5%	SRD1/8P	R234	0129631	Carbon film	10k Ω	\pm 5%	SRD1/8P	
R171	0129621	Carbon film	6.8k Ω	\pm 5%	SRD1/8P	R236	0129631	Carbon film	10k Ω	\pm 5%	SRD1/8P	
R172	0129631	Carbon film	10k Ω	\pm 5%	SRD1/8P	R237	0129569	Carbon film	220 Ω	\pm 5%	SRD1/8P	
R173	0129677	Carbon film	470k Ω	\pm 5%	SRD1/8P	R238	0129611	Carbon film	2.7k Ω	\pm 5%	SRD1/8P	
R174	0129637	Carbon film	18k Ω	\pm 5%	SRD1/8P	R239	0129617	Carbon film	4.7k Ω	\pm 5%	SRD1/8P	
R175	0129631	Carbon film	10k Ω	\pm 5%	SRD1/8P	R240	0129643	Carbon film	33k Ω	\pm 5%	SRD1/8P	
R176	0129631	Carbon film	10k Ω	\pm 5%	SRD1/8P	R241	0129661	Carbon film	100k Ω	\pm 5%	SRD1/8P	
R177	0129631	Carbon film	10k Ω	\pm 5%	SRD1/8P	R242	0129631	Carbon film	10k Ω	\pm 5%	SRD1/8P	
R178	0129669	Carbon film	220k Ω	\pm 5%	SRD1/8P	R243	0129661	Carbon film	100k Ω	\pm 5%	SRD1/8P	
R179	0129601	Carbon film	1k Ω	\pm 5%	SRD1/8P	R244	0129661	Carbon film	100k Ω	\pm 5%	SRD1/8P	
R180	0129605	Carbon film	1.5k Ω	\pm 5%	SRD1/8P	Δ R301	0110622	Metal (Fuse resistor)	120 Ω	\pm 5%	RN1/4B	
R181	0129615	Carbon film	3.9k Ω	\pm 5%	SRD1/8P	R302	0129643	Carbon film	33k Ω	\pm 5%	SRD1/8P	
R201	0129601	Carbon film	1k Ω	\pm 5%	SRD1/8P	R304	0129601	Carbon film	1k Ω	\pm 5%	SRD1/8P	
R202	0129547	Carbon film	47 Ω	\pm 5%	SRD1/8P	R305	0129665	Carbon film	150k Ω	\pm 5%	SRD1/8P	
R203	0129547	Carbon film	47 Ω	\pm 5%	SRD1/8P	R306	0129665	Carbon film	150k Ω	\pm 5%	SRD1/8P	
R204	0129573	Carbon film	330 Ω	\pm 5%	SRD1/8P	R307	0129631	Carbon film	10k Ω	\pm 5%	SRD1/8P	
					R308	0129641	Carbon film	27k Ω	\pm 5%	SRD1/8P		
					R309	0129641	Carbon film	27k Ω	\pm 5%	SRD1/8P		
					R310	0129663	Carbon film	120k Ω	\pm 5%	SRD1/8P		
					R310	0129669	Carbon film	220k Ω	\pm 5%	SRD1/8P		
					(for EW, US, CS)	R311	0129643	Carbon film	33k Ω	\pm 5%	SRD1/8P	
					(for VK, BS, SA, ZW)	R312	0129643	Carbon film	33k Ω	\pm 5%	SRD1/8P	
					R313	0129631	Carbon film	10k Ω	\pm 5%	SRD1/8P		
					R314	0129631	Carbon film	10k Ω	\pm 5%	SRD1/8P		
					R315	0129603	Carbon film	1.2k Ω	\pm 5%	SRD1/8P		
					R316	0129603	Carbon film	1.2k Ω	\pm 5%	SRD1/8P		
					R317	0129631	Carbon film	10k Ω	\pm 5%	SRD1/8P		
					R318	0129631	Carbon film	10k Ω	\pm 5%	SRD1/8P		
					R319	0129617	Carbon film	4.7k Ω	\pm 5%	SRD1/8P		
					R320	0129617	Carbon film	4.7k Ω	\pm 5%	SRD1/8P		

SYMBOL NO.	PART NO.	DESCRIPTION			SYMBOL NO.	PART NO.	DESCRIPTION				
R501	0129601	Carbon film	1kΩ	±5%	SRD1/8P	R559	0129671	Carbon film (for VK, BS, SA, ZW)	270kΩ	±5%	SRD1/8P
R502	0129631	Carbon film	10kΩ	±5%	SRD1/8P	R560	0129926	Carbon film (for EW, ZW, CS, US)	220kΩ	±5%	SRD1/4P
R503	0129709	Carbon film	2.2MΩ	±5%	SRD1/8P	R561	0129926	Carbon film (for EW, ZW, CS, US)	220kΩ	±5%	SRD1/4P
R504	0129581	Carbon film	680Ω	±5%	SRD1/8P	R562	0129918	Carbon film (for EW, ZW, CS, US)	100kΩ	±5%	SRD1/4P
R505	0129605	Carbon film	1.5kΩ	±5%	SRD1/8P	R563	0129918	Carbon film (for EW, ZW, CS, US)	100kΩ	±5%	SRD1/4P
R506	0129661	Carbon film	100kΩ	±5%	SRD1/8P	R564	0129661	Carbon film	100kΩ	±5%	SRD1/8P
R507	0129635	Carbon film	15kΩ	±5%	SRD1/8P	△ R801	0110611	Metal (Fuse resistor)	68Ω	±5%	RN1/4B
R508	0129709	Carbon film	2.2MΩ	±5%	SRD1/8P	R802	0129619	Carbon film	5.6kΩ	±5%	SRD1/8P
R509	0129631	Carbon film	10kΩ	±5%	SRD1/8P	R803	0129601	Carbon film	1kΩ	±5%	SRD1/8P
R510	0129631	Carbon film	10kΩ	±5%	SRD1/8P	R804	0129615	Carbon film	3.9kΩ	±5%	SRD1/8P
R511	0129631	Carbon film	10kΩ	±5%	SRD1/8P	R805	0129631	Carbon film	10kΩ	±5%	SRD1/8P
R512	0129601	Carbon film	1kΩ	±5%	SRD1/8P	R806	0129649	Carbon film	56kΩ	±5%	SRD1/8P
R513	0129571	Carbon film	270Ω	±5%	SRD1/8P	R807	0129601	Carbon film	1kΩ	±5%	SRD1/8P
R514	0129607	Carbon film	1.8kΩ	±5%	SRD1/8P	R808	0129605	Carbon film	1.5kΩ	±5%	SRD1/8P
R515	0129621	Carbon film	6.8kΩ	±5%	SRD1/8P	R809	0129661	Carbon film	100kΩ	±5%	SRD1/8P
R516	0129621	Carbon film	6.8kΩ	±5%	SRD1/8P	R810	0129613	Carbon film	3.3kΩ	±5%	SRD1/8P
R517	0129621	Carbon film	6.8kΩ	±5%	SRD1/8P	R811	0129611	Carbon film	2.7kΩ	±5%	SRD1/8P
R518	0129613	Carbon film	3.3kΩ	±5%	SRD1/8P	R812	0129613	Carbon film	3.3kΩ	±5%	SRD1/8P
R519	0129613	Carbon film	3.3kΩ	±5%	SRD1/8P	R813	0129635	Carbon film	15kΩ	±5%	SRD1/8P
R520	0129613	Carbon film	3.3kΩ	±5%	SRD1/8P	△ R814	0110623	Metal (Fuse resistor)	150Ω	±5%	RN1/4B
R521	0129609	Carbon film	2.2kΩ	±5%	SRD1/8P	R815	0129615	Carbon film	3.9kΩ	±5%	SRD1/8P
R522	0129661	Carbon film	100kΩ	±5%	SRD1/8P	R816	0129613	Carbon film	3.3kΩ	±5%	SRD1/8P
R525	0129661	Carbon film	100kΩ	±5%	SRD1/8P	R991LR	0129906	Carbon film	33kΩ	±5%	SRD1/4P
R526	0129661	Carbon film	100kΩ	±5%	SRD1/8P	R992LR	0129890	Carbon film	6.8kΩ	±5%	SRD1/4P
R527	0129613	Carbon film	3.3kΩ	±5%	SRD1/8P	R993LR	0129922	Carbon film	150kΩ	±5%	SRD1/4P
R528	0129613	Carbon film	3.3kΩ	±5%	SRD1/8P	R994LR	0129900	Carbon film	18kΩ	±5%	SRD1/4P
R529	0129613	Carbon film	3.3kΩ	±5%	SRD1/8P	R995LR	0129619	Carbon film	5.6kΩ	±5%	SRD1/8P
R530	0129894	Carbon film	10kΩ	±5%	SRD1/4P	R996LR	0129894	Carbon film	10kΩ	±5%	SRD1/4P
R531	0129894	Carbon film	10kΩ	±5%	SRD1/4P	R998	0113293	Carbon film	330Ω	±5%	SRD1/2P
R532	0129894	Carbon film	10kΩ	±5%	SRD1/4P	△ R999	0110601	Metal (Fuse resistor)	10Ω	±5%	RN1/2B
R533	0129601	Carbon film	1kΩ	±5%	SRD1/8P	for PA P.W.B.					
R534	0129631	Carbon film	10kΩ	±5%	SRD1/8P	R401LR	0129547	Carbon film	47Ω	±5%	SRD1/8P
R535	0129601	Carbon film	1kΩ	±5%	SRD1/8P	R402LR	0129647	Carbon film	47kΩ	±5%	SRD1/8P
R536	0129926	Carbon film	220kΩ	±5%	SRD1/4P	R403LR	0129563	Carbon film	120Ω	±5%	SRD1/8P
R537	0129926	Carbon film	220kΩ	±5%	SRD1/4P	R404LR	0129579	Carbon film	560Ω	±5%	SRD1/8P
R538	0129918	Carbon film	100kΩ	±5%	SRD1/4P	R405LR	0129653	Carbon film	82kΩ	±5%	SRD1/8P
R539	0129661	Carbon film	100kΩ	±5%	SRD1/8P	R406LR	0129619	Carbon film	5.6kΩ	±5%	SRD1/8P
R540	0129926	Carbon film	220kΩ	±5%	SRD1/4P	R407LR	0129561	Carbon film	100Ω	±5%	SRD1/8P
R541	0129926	Carbon film	220kΩ	±5%	SRD1/4P	R408LR	0129605	Carbon film	1.5kΩ	±5%	SRD1/8P
R542	0129661	Carbon film	100kΩ	±5%	SRD1/8P	R409LR	0129647	Carbon film	47kΩ	±5%	SRD1/8P
R543	0129918	Carbon film	100kΩ	±5%	SRD1/4P	△ R410	0110621	Metal (Fuse resistor)	100Ω	±5%	RN1/4B
R544	0129926	Carbon film	220kΩ	±5%	SRD1/4P	△ R411	0110621	Metal (Fuse resistor)	100Ω	±5%	RN1/4B
R545	0129926	Carbon film	220kΩ	±5%	SRD1/4P	R453LR	0129643	Carbon film	33kΩ	±5%	SRD1/8P
R546	0129918	Carbon film	100kΩ	±5%	SRD1/4P	R611LR	0129601	Carbon film	1kΩ	±5%	SRD1/8P
R547	0129918	Carbon film	100kΩ	±5%	SRD1/4P	R612LR	0129635	Carbon film	15kΩ	±5%	SRD1/8P
R548	0129631	Carbon film (for VK, BS, SA, ZW)	10kΩ	±5%	SRD1/8P	R613LR	0129647	Carbon film	47kΩ	±5%	SRD1/8P
R549	0129601	Carbon film	1kΩ	±5%	SRD1/8P	R614LR	0129665	Carbon film	150kΩ	±5%	SRD1/8P
R550	0129631	Carbon film (for VK, BS, SA, ZW)	10kΩ	±5%	SRD1/8P	R615LR	0129581	Carbon film	680Ω	±5%	SRD1/8P
R551	0129605	Carbon film (for VK, BS, SA, ZW)	1.5kΩ	±5%	SRD1/8P	R616LR	0129583	Carbon film	820Ω	±5%	SRD1/8P
R552	0129926	Carbon film	220kΩ	±5%	SRD1/4P	R617LR	0129663	Carbon film	120kΩ	±5%	SRD1/8P
R553	0129926	Carbon film (for VK, BS, SA, ZW)	220kΩ	±5%	SRD1/4P	R618LR	0129633	Carbon film	12kΩ	±5%	SRD1/8P
R554	0129918	Carbon film	100kΩ	±5%	SRD1/4P	R619LR	0129607	Carbon film	1.8kΩ	±5%	SRD1/8P
R555	0129918	Carbon film (for VK, BS, SA, ZW)	100kΩ	±5%	SRD1/4P	R620LR	0129613	Carbon film	3.3kΩ	±5%	SRD1/8P
R556	0129669	Carbon film (for VK, BS, SA, ZW)	220kΩ	±5%	SRD1/8P	R622LR	0129635	Carbon film	15kΩ	±5%	SRD1/8P
R557	0129671	Carbon film (for VK, BS, SA, ZW)	270kΩ	±5%	SRD1/8P	R623LR	0129619	Carbon film	5.6kΩ	±5%	SRD1/8P
R558	0129669	Carbon film (for VK, BS, SA, ZW)	220kΩ	±5%	SRD1/8P						

HITACHI HTD-G2

SYMBOL NO.	PART NO.	DESCRIPTION				SYMBOL NO.	PART NO.	DESCRIPTION			
R649LR	0129643	Carbon film	33k Ω	$\pm 5\%$	SRD1/8P	R860	0129601	Carbon film	1k Ω	$\pm 5\%$	SRD1/8P
R944	0129609	Carbon film	2.2k Ω	$\pm 5\%$	SRD1/8P	R861	0129607	Carbon film	1.8k Ω	$\pm 5\%$	SRD1/8P
R946	0129623	Carbon film	8.2k Ω	$\pm 5\%$	SRD1/8P	R862	0129601	Carbon film	1k Ω	$\pm 5\%$	SRD1/8P
for DE P.W.B.						R863	0129601	Carbon film	1k Ω	$\pm 5\%$	SRD1/8P
R001	0139005	Composition (for CS, US)	2.7M Ω	$\pm 10\%$	RC1/2GF	R864	0129649	Carbon film	56k Ω	$\pm 5\%$	SRD1/8P
R451LR	H129631	Carbon film	10k Ω	$\pm 5\%$	SRD1/8P	R865	0129649	Carbon film	56k Ω	$\pm 5\%$	SRD1/8P
R452LR	H129579	Carbon film	560 Ω	$\pm 5\%$	SRD1/8P	R866	0129631	Carbon film	10k Ω	$\pm 5\%$	SRD1/8P
R454LR	0129619	Carbon film	5.6k Ω	$\pm 5\%$	SRD1/8P	R867	0129601	Carbon film	1k Ω	$\pm 5\%$	SRD1/8P
R455LR	0129643	Carbon film	33k Ω	$\pm 5\%$	SRD1/8P	R868	0129649	Carbon film	56k Ω	$\pm 5\%$	SRD1/8P
R456LR	0129601	Carbon film	1k Ω	$\pm 5\%$	SRD1/8P	R869	0129631	Carbon film	10k Ω	$\pm 5\%$	SRD1/8P
R457LR	0129647	Carbon film	47k Ω	$\pm 5\%$	SRD1/8P	R870	0129639	Carbon film	22k Ω	$\pm 5\%$	SRD1/8P
R458LR	0129681	Carbon film	680k Ω	$\pm 5\%$	SRD1/8P	R871LR	0129605	Carbon film	1.5k Ω	$\pm 5\%$	SRD1/8P
R459LR	0129581	Carbon film	680 Ω	$\pm 5\%$	SRD1/8P	R872	0129615	Carbon film	3.9k Ω	$\pm 5\%$	SRD1/8P
R460LR	0129601	Carbon film	1k Ω	$\pm 5\%$	SRD1/8P	R873	0129631	Carbon film	10k Ω	$\pm 5\%$	SRD1/8P
R601LR	0129601	Carbon film	1k Ω	$\pm 5\%$	SRD1/8P	R874	0129639	Carbon film	22k Ω	$\pm 5\%$	SRD1/8P
R603	0129669	Carbon film	220k Ω	$\pm 5\%$	SRD1/8P	R876	0129631	Carbon film	10k Ω	$\pm 5\%$	SRD1/8P
R604	0129643	Carbon film	33k Ω	$\pm 5\%$	SRD1/8P	R877	0129631	Carbon film	10k Ω	$\pm 5\%$	SRD1/8P
R605	0129669	Carbon film	220k Ω	$\pm 5\%$	SRD1/8P	R878	0129649	Carbon film	56k Ω	$\pm 5\%$	SRD1/8P
R606	0129643	Carbon film	33k Ω	$\pm 5\%$	SRD1/8P	R879	0129649	Carbon film	56k Ω	$\pm 5\%$	SRD1/8P
R607	0129669	Carbon film	220k Ω	$\pm 5\%$	SRD1/8P	R880	0129649	Carbon film	56k Ω	$\pm 5\%$	SRD1/8P
R608	0129643	Carbon film	33k Ω	$\pm 5\%$	SRD1/8P	R881	0149475	Wire wound	22 Ω	$\pm 5\%$	RW7H
R609	0129669	Carbon film	220k Ω	$\pm 5\%$	SRD1/8P	R883	0129613	Carbon film	3.3k Ω	$\pm 5\%$	SRD1/8P
R610	0129643	Carbon film	33k Ω	$\pm 5\%$	SRD1/8P	R884	0129601	Carbon film	1k Ω	$\pm 5\%$	SRD1/8P
R624LR	0129671	Carbon film	270k Ω	$\pm 5\%$	SRD1/8P	R885	0129601	Carbon film	1k Ω	$\pm 5\%$	SRD1/8P
R625LR	0129677	Carbon film	470k Ω	$\pm 5\%$	SRD1/8P	R886	0129619	Carbon film	5.6k Ω	$\pm 5\%$	SRD1/8P
R626LR	0129621	Carbon film	6.8k Ω	$\pm 5\%$	SRD1/8P	Δ R887	0110605	Metal (Fuse resistor)	22 Ω	$\pm 5\%$	RN1/4B
R627LR	0129613	Carbon film	3.3k Ω	$\pm 5\%$	SRD1/8P	R888	0129631	Carbon film	10k Ω	$\pm 5\%$	SRD1/8P
R628LR	0129665	Carbon film	150k Ω	$\pm 5\%$	SRD1/8P	Δ R890	0110627	Metal (Fuse resistor)	330 Ω	$\pm 5\%$	RN1/4B
R629	0129551	Carbon film	68 Ω	$\pm 5\%$	SRD1/8P	Δ R892	0110605	Metal (Fuse resistor)	22 Ω	$\pm 5\%$	RN1/4B
R630LR	0129601	Carbon film	1k Ω	$\pm 5\%$	SRD1/8P	R899	0129561	Carbon film	100 Ω	$\pm 5\%$	SRD1/8P
R631	0129649	Carbon film	56k Ω	$\pm 5\%$	SRD1/8P	R902LR	0129647	Carbon film	47k Ω	$\pm 5\%$	SRD1/8P
R633	0129669	Carbon film	220k Ω	$\pm 5\%$	SRD1/8P	R903LR	0129617	Carbon film	4.7k Ω	$\pm 5\%$	SRD1/8P
R634	0129643	Carbon film	33k Ω	$\pm 5\%$	SRD1/8P	R904LR	0129667	Carbon film	180k Ω	$\pm 5\%$	SRD1/8P
R642	0129639	Carbon film	22k Ω	$\pm 5\%$	SRD1/8P	R905LR	0129621	Carbon film	6.8k Ω	$\pm 5\%$	SRD1/8P
R643	0129649	Carbon film	56k Ω	$\pm 5\%$	SRD1/8P	R906LR	0129609	Carbon film	2.2k Ω	$\pm 5\%$	SRD1/8P
R644	0129910	Carbon film	47k Ω	$\pm 5\%$	SRD1/4P	R907LR	0129679	Carbon film	560k Ω	$\pm 5\%$	SRD1/8P
R645	0129918	Carbon film	100k Ω	$\pm 5\%$	SRD1/4P	R908LR	0129613	Carbon film	3.3k Ω	$\pm 5\%$	SRD1/8P
R646LR	0129950	Carbon film	2.2M Ω	$\pm 5\%$	SRD1/4P	R909	0129601	Carbon film	1k Ω	$\pm 5\%$	SRD1/8P
Δ R647	0110621	Metal (fuse resistor)	100 Ω	$\pm 5\%$	RN1/4B	R910LR	0129661	Carbon film	100k Ω	$\pm 5\%$	SRD1/8P
R648LR	0129643	Carbon film	33k Ω	$\pm 5\%$	SRD1/8P	R911LR	0129631	Carbon film	10k Ω	$\pm 5\%$	SRD1/8P
R651LR	0129601	Carbon film	1k Ω	$\pm 5\%$	SRD1/8P	R912LR	0129613	Carbon film	3.3k Ω	$\pm 5\%$	SRD1/8P
R652LR	0129631	Carbon film	10k Ω	$\pm 5\%$	SRD1/8P	R913LR	0129641	Carbon film	27k Ω	$\pm 5\%$	SRD1/8P
R653LR	0129583	Carbon film	820 Ω	$\pm 5\%$	SRD1/8P	R914LR	0129663	Carbon film	120k Ω	$\pm 5\%$	SRD1/8P
R654LR	0129619	Carbon film	5.6k Ω	$\pm 5\%$	SRD1/8P	R915LR	0129531	Carbon film	10 Ω	$\pm 5\%$	SRD1/8P
R655LR	0129553	Carbon film	82 Ω	$\pm 5\%$	SRD1/8P	R938LR	0129618	Carbon film	5.1k Ω	$\pm 5\%$	SRD1/8P
Δ R656	0110621	Metal (Fuse resistor)	100 Ω	$\pm 5\%$	RN1/4B	R940	0129661	Carbon film	100k Ω	$\pm 5\%$	SRD1/8P
Δ R657	0110621	Metal (Fuse resistor)	100 Ω	$\pm 5\%$	RN1/4B	R941	0129631	Carbon film	10k Ω	$\pm 5\%$	SRD1/8P
R851	0129561	Carbon film	100 Ω	$\pm 5\%$	SRD1/8P	R942	0129621	Carbon film	6.8k Ω	$\pm 5\%$	SRD1/8P
R852	0129649	Carbon film	56k Ω	$\pm 5\%$	SRD1/8P	R946LR	0129613	Carbon film	3.3k Ω	$\pm 5\%$	SRD1/8P
R853	0129617	Carbon film	4.7k Ω	$\pm 5\%$	SRD1/8P	R947LR	0129641	Carbon film	27k Ω	$\pm 5\%$	SRD1/8P
R854	0129649	Carbon film	56k Ω	$\pm 5\%$	SRD1/8P	R948LR	0129643	Carbon film	33k Ω	$\pm 5\%$	SRD1/8P
R855	0129649	Carbon film	56k Ω	$\pm 5\%$	SRD1/8P	R949LR	0129677	Carbon film	470k Ω	$\pm 5\%$	SRD1/8P
R856	0129651	Carbon film	68k Ω	$\pm 5\%$	SRD1/8P	R950LR	0129649	Carbon film	56k Ω	$\pm 5\%$	SRD1/8P
R857	0129651	Carbon film	68k Ω	$\pm 5\%$	SRD1/8P	R951LR	0129631	Carbon film	10k Ω	$\pm 5\%$	SRD1/8P
R858	0129649	Carbon film	56k Ω	$\pm 5\%$	SRD1/8P	R952LR	0129603	Carbon film	1.2k Ω	$\pm 5\%$	SRD1/8P
R859	0129649	Carbon film	56k Ω	$\pm 5\%$	SRD1/8P	R953LR	0129605	Carbon film	1.5k Ω	$\pm 5\%$	SRD1/8P
						R954LR	0129605	Carbon film	1.5k Ω	$\pm 5\%$	SRD1/8P
						R955LR	0129603	Carbon film	1.2k Ω	$\pm 5\%$	SRD1/8P
						R956LR	0129617	Carbon film	4.7k Ω	$\pm 5\%$	SRD1/8P

SYMBOL NO.	PART NO.	DESCRIPTION			
R957LR	0129603	Carbon film	1.2k Ω	$\pm 5\%$	SRD1/8P
R958LR	0129607	Carbon film	1.8k Ω	$\pm 5\%$	SRD1/8P
R960	0129631	Carbon film	10k Ω	$\pm 5\%$	SRD1/8P
R963	0113292	Carbon film	270 Ω	$\pm 5\%$	SRD1/2P
R964	0113225	Carbon film	47 Ω	$\pm 5\%$	SRD1/2P
R965	0113290	Carbon film	180 Ω	$\pm 5\%$	SRD1/2P
R966	0129643	Carbon film	33k Ω	$\pm 5\%$	SRD1/8P
Δ R969	0110601	Metal (Fuse resistor)	10 Ω	$\pm 5\%$	RN1/4B
R971LR	0129673	Carbon film	330k Ω	$\pm 5\%$	SRD1/8P
R974	0129643	Carbon film	33k Ω	$\pm 5\%$	SRD1/8P
R975	0129643	Carbon film	33k Ω	$\pm 5\%$	SRD1/8P
R976LR	0129631	Carbon film	10k Ω	$\pm 5\%$	SRD1/8P
R977LR	0129631	Carbon film	10k Ω	$\pm 5\%$	SRD1/8P
R978	0129613	Carbon film	3.3k Ω	$\pm 5\%$	SRD1/8P
R979	0129613	Carbon film	3.3k Ω	$\pm 5\%$	SRD1/8P
R980	0129611	Carbon film	2.7k Ω	$\pm 5\%$	SRD1/8P
R987LR	0129677	Carbon film	470k Ω	$\pm 5\%$	SRD1/8P
R988	0129621	Carbon film	6.8k Ω	$\pm 5\%$	SRD1/8P
R989	0129603	Carbon film	1.2k Ω	$\pm 5\%$	SRD1/8P

ICs & TRANSISTORS

for TU P.W.B.

IC201	2367281	HA11211
IC301	2367271	HA1196
IC501	2369041	LB1240
IC502	2368741	μ PB553AC
IC503	2369031	μ PD1703C - 018
IC504	2369051	SN74LS137
IC505	2368171	SN16880
IC801	2369794	μ PC7815H
IC991LR	2368631	IR - 2E01
Q151	2328802	2SK104 $\text{\textcircled{F}}$
Q152	2329323	2SC460 $\text{\textcircled{C}}$
Q153	2329323	2SC460 $\text{\textcircled{C}}$
Q154	2329951	2SD655 $\text{\textcircled{D}}$ (for VK, BS, SA, ZW)
Q155	2328802	2SK104 $\text{\textcircled{F}}$ (for VK, BS, SA, ZW)
Q156	2328652	2SC1740LN $\text{\textcircled{S}}$ (for VK, BS, SA, ZW)
Q157	2328652	2SC1740LN $\text{\textcircled{S}}$ (for VK, BS, SA, ZW)
Q201	2329323	2SC460 $\text{\textcircled{C}}$
Q202	2328652	2SC1740LN $\text{\textcircled{S}}$
Q203	2328652	2SC1740LN $\text{\textcircled{S}}$
Q204	2328652	2SC1740LN $\text{\textcircled{S}}$
Q301	2328652	2SC1740LN $\text{\textcircled{S}}$
Q302	2328652	2SC1740LN $\text{\textcircled{S}}$
Q501	2328653	2SC1740LN $\text{\textcircled{E}}$
Q502	2328653	2SC1740LN $\text{\textcircled{E}}$
Q503	2328652	2SC1740LN $\text{\textcircled{S}}$
Q504	2328652	2SC1740LN $\text{\textcircled{S}}$
Q505	2329183	2SA1015 $\text{\textcircled{GR}}$
Q509	2329183	2SA1015 $\text{\textcircled{GR}}$

SYMBOL NO.	PART NO.	DESCRIPTION
Q510	2328652	2SC1740LN $\text{\textcircled{S}}$
Q511	2329183	2SA1015 $\text{\textcircled{GR}}$
Q512	2328652	2SC1740LN $\text{\textcircled{S}}$
Q513	2329183	2SA1015 $\text{\textcircled{GR}}$
Q514	2328652	2SC1740LN $\text{\textcircled{S}}$
Q515	2328653	2SC1740LN $\text{\textcircled{E}}$ (for VK, BS, SA, ZW)
Q516	2328653	2SC1740LN $\text{\textcircled{E}}$ (for VK, BS, SA, ZW)
Q517	2329183	2SA1015 $\text{\textcircled{GR}}$ (for VK, BS, SA, ZW)
Q518	2328652	2SC1740LN $\text{\textcircled{S}}$ (for VK, BS, SA, ZW)
Q519	2329183	2SA1015 $\text{\textcircled{GR}}$ (for VK, BS, SA, ZW)
Q520	2329183	2SA1015 $\text{\textcircled{GR}}$ (for VK, BS, SA, ZW)
Q521	2329183	2SA1015 $\text{\textcircled{GR}}$ (for EW, ZW, CS, US)
Q522	2328652	2SC1740LN $\text{\textcircled{S}}$ (for EW, ZW, CS, US)
Q523	2328652	2SC1740LN $\text{\textcircled{S}}$
Q801	2328632	2SD667A $\text{\textcircled{C}}$
Q802	2328632	2SD667A $\text{\textcircled{C}}$
Q803	2329183	2SA1015 $\text{\textcircled{GR}}$
Q804	2328622	2SB647A $\text{\textcircled{C}}$
Q805	2328622	2SB647A $\text{\textcircled{C}}$
for PA P.W.B.		
IC401LR	2367922	M5214L
IC603LR	2367922	M5214L
for DE P.W.B.		
IC451LR	2369841	M5219L
IC601	2368831	CX770
IC602	2368831	CX770
IC651LR	2369351	μ PC4557DX
IC851	2369315	μ PD554C - 081
IC901LR	2368503	BA340
IC903LR	2377431	TM3501
IC904	2369701	TC4066BP
Q451LR	2328652	2SC1740LN $\text{\textcircled{S}}$
Q601LR	2328652	2SC1740LN $\text{\textcircled{S}}$
Q602	2328652	2SC1740LN $\text{\textcircled{S}}$
Q648LR	2328642	2SA825 $\text{\textcircled{D}}$
Q649LR	2329243	2SK246
Q851LR	2329561	2SC1845EF
Q852LR	2329561	2SC1845EF
Q853LR	2328652	2SC1740LN $\text{\textcircled{S}}$
Q854	2329571	2SA992EF
Q855	2328652	2SC1740LN $\text{\textcircled{S}}$
Q857	2328652	2SC1740LN $\text{\textcircled{S}}$
Q858	2328652	2SC1740LN $\text{\textcircled{S}}$
Q859	2328652	2SC1740LN $\text{\textcircled{S}}$
Q860	2329591	2SD985
Q861	2329591	2SD985
Q862	2329591	2SD985
Q865	2328652	2SC1740LN $\text{\textcircled{S}}$
Q866	2328652	2SC1740LN $\text{\textcircled{S}}$
Q868	2328002	2SD468 $\text{\textcircled{E}}$
Q901LR	2328652	2SC1740LN $\text{\textcircled{S}}$

HITACHI HTD-G2

SYMBOL NO.	PART NO.	DESCRIPTION
Q907LR	2328652	2SC1740LN Ⓢ
Q909	2327283	2SA673A Ⓢ
Q910	2329561	2SC1845EF
Q911	2329561	2SC1845EF
DIODES		
for TU P.W.B.		
D101	2337011	1S2076
D102	2337011	1S2076
D151	2337011	1S2076
D152	2337011	1S2076
D153	2338541	KV1226
D154	2338541	KV1226 (for VK, BS, SA, ZW)
D155		
D158		
D156		
D156	2337011	1S2076 (for VK, BS, SA, ZW)
D157	2337011	1S2076 (for VK, BS, SA, ZW)
D159	2337011	1S2076 (for VK, BS, SA, ZW)
D160	2337011	1S2076 (for VK, BS, SA, ZW)
D201	2337011	1S2076
D202	2337011	1S2076
D203	2337011	1S2076
D204	2337921	1K34A
D205	2337921	1K34A
D206	2337011	1S2076
⌋	⌋	⌋
D209	2337011	1S2076
D210	2337011	1S2076 (for VK, BS, SA, ZW)
D211	2337011	1S2076 (for VK, BS, SA, ZW)
D212	2337011	1S2076 (for VK, BS, SA, ZW)
D213	2337011	1S2076
D301	2337011	1S2076
⌋	⌋	⌋
D304	2337011	1S2076
D502	2337011	1S2076
⌋	⌋	⌋
D506	2337011	1S2076
D513	2337011	1S2076 (for VK, BS, SA, ZW)
D514	2337011	1S2076 (for VK, BS, SA, ZW)
D515	2337011	1S2076
⌋	⌋	⌋
D525	2337011	1S2076
D526	2337011	1S2076 (for VK, BS, SA, ZW)
D527	2337011	1S2076
D528	2337011	1S2076 (for VK, BS, SA, ZW)
D529	2337011	1S2076 (for VK, BS, SA, ZW)
D530	2338012	1S2473HC
D801	2337762	ERB12-01R
⌋	⌋	⌋
D805	2337762	ERB12-01R
D806	2337011	1S2076
D807	2337011	1S2076
D808	2337762	ERB12-01R
D901	2339351	LED pack
ZD201	2338617	RD10EN1
ZD202	2338583	HZ3EN2

SYMBOL NO.	PART NO.	DESCRIPTION
ZD301	2338583	HZ3EN2
ZD801	2338604	RD6.2EN3
ZD802	2338657	RD30EB3
ZD803	2338602	RD6.2EN1
ZD804	2338651	RD27EB1
ZD805	2338602	RD6.2EN1
ZD806	2338633	RD16EN1
for PA P.W.B.		
D607	2337011	1S2076
D866	2338411	SLC-22UR
D905	2338411	SLC-22UR
for DE P.W.B.		
D451LR	2337011	1S2076
D601	2337011	1S2076 (for VK, BS, SA, ZW)
D602	2337011	1S2076 (for VK, BS, SA, ZW)
D604	2337011	1S2076
D605	2337011	1S2076
D606	2337011	1S2076
D608	2337762	ERB12-01R
D647	2337011	1S2076
D648	2338011	1S2473
D649LR	2338011	1S2473
D851	2337011	1S2076
⌋	⌋	⌋
D855	2337011	1S2076
D857	2337011	1S2076
D858	2337011	1S2076
D861	2337762	ERB12-01R
D862	2337762	ERB12-01R
D864	2337762	ERB12-01R
D899	2337762	ERB12-01R
D901	2337011	1S2076
⌋	⌋	⌋
D905	2337011	1S2076
D949	2337011	1S2076
ZD851	2338606	RD6.8EN2
ZD852	2338606	RD6.8EN2
ZD853	2338622	RD11EN2
ZD854	2338617	RD10EN1
ZD901	2338582	RD3.0EN1
VARIABLE RESISTORS		
for TU P.W.B.		
R227	0150960	50k Ω -(B) (Mute bandwidth adj.)
R303	0150958	10k Ω -(B) (76kHz free running adj.)

SYMBOL NO.	PART NO.	DESCRIPTION	SYMBOL NO.	PART NO.	DESCRIPTION
for PA P.W.B.					
RV601LR	0158571	50k Ω - (C) (Treble control)	MF201	2135002	FM ceramic filter
RV602LR	0158571	50k Ω - (C) (Bass control)	MF202	2135002	FM ceramic filter
RV603LR	0158581	200k Ω - (W) (Balance control)	MF251	2154481	AM ceramic filter
RV604LR	0158551	100k Ω - (B) (Volume control)	X501	2787941	Crystal oscillator (4.50MHz)
RV651LR	0158572	10k Ω - (B) (Mic volume control)	CP501	0189031	Resistor array (39k Ω x 4)
RV901LR	0158561	50k Ω - (B) (Record level control)	CP502	0189014	Resistor array (100k Ω x 7)
for DE P.W.B.			CP503	0241892	Capacitor array (330pF x 7)
RT901LR	0158929	200k Ω - (B) (Bias current adj.)	CT151	0283127	Trimmer capacitor (20pF)
RT902LR	0150959	20k Ω - (B) (Playback output level adj.)	CT152	0283127	Trimmer capacitor (20pF) (for VK, BS, SA, ZW)
RT903LR	0158925	10k Ω - (B) (Record/playback output level adj.)	FL501	2788621	Fluorecent display tube
COILS & TRANSFORMERS			CP901	2788471	BIAS OSC block
for TU P.W.B.			RL601	2647191	Miniture relay
L151	2227353	Choke coil - 100 μ H	Δ S002	2627221	Voltage change switch (for ZW, EW)
L152	2135062	MW RF coil	S501	2627531	Slide switch (for EW, ZW, CS, US)
L153	2135066	LW RF coil (for VK, BS, SA, ZW)	S601	2639712	Push switch (for US, CS, EW) (FUNCTION)
L201	2227354	Choke coil - 2.2 μ H	S601	2639711	Push switch (for ZW, SA, BS, VK) (FUNCTION)
L202	2227351	Choke coil - 1 μ H	S502	2639731	Push switch (FM TUNING)
L203	2134931	Trap coil (for VK, BS, SA, ZW)	602		Push switch (LOUDNESS)
L503	2227395	Choke coil - 1mH	604		Push switch (FM MODE)
T151	2135127	MW OSC coil	S851	2647461	Lead relay
T152	2154491	AM IFT coil	S852	2627561	Slide switch (TIMER)
T153	2135128	LW OSC coil (for VK, BS, SA, ZW)	S901	2639721	Push switch (Tape selector, Dolby)
T201	2154302	AM IF transformer	S902	2628151	Slide switch (RIF)
T202	2154432	FM discriminating transformer	Δ S001	2639512	Power switch (for US, CS)
T203	2154433	FM discriminating transformer	Δ S001	2639513	Power switch (for ZW, SA, BS, VK, EW)
for DE P.W.B.			J401	2677611	4P US pin jack (PHONO, LINE OUTPUT)
L851	2154823	AM - IF transformer	605		
L852	2227393	Choke coil - 100mH	J602	2677611	4P US pin jack (LINE INPUT, OUTPUT)
L853	2227393	Choke coil - 100mH	603		
L901LR	2227355	Choke coil - 1mH	J451	2677752	Headphone jack
L902	2227353	Choke coil - 100mH	J452	2677761	Mic jack
L903	2227353	Choke coil - 100mH	J601	2677741	4P US pin jack (AUX IN, REC OUT)
LC901LR	2136041	Dolby filter	604		
LC902LR	2135624	Trap coil		2425381	Tuner pack
LC903LR	2136031	Bias trap coil		2688201	5P Antenna terminal (for EW, CS, US)
MISCELLANEOUS				2688202	5P Antenna terminal (for VK, BS, SA, ZW)
Δ CPO01	0243899	Ceramic discal (0.01 μ F, 125V) (for US, CS)		2727681	Fuse holder
Δ CPO01	0243901	Ceramic discal (0.01 μ F, 400V) (for ZW, SA, BS, VK, EW)	Δ F001	2727895	Fuse (UL: 1A, SLOW) (for CS, US)
			Δ F001	2727197	Fuse (T500mA) (except CS, US)
				2667995	6P miniture plug (for record/playback head)
				2667993	4P miniture plug (for solenoid)
				2667573	4P pin assembly (for REC EJECT SW)
				2667571	2P pin assembly (for Erase head)
				2667951	1P pin post (white)
				2668481	3P connector (P.W.B. fixing)
				2668483	5P connector (P.W.B. fixing)
for ACCESSORIES					
				2718542	FM antenna
				2757462	Loop antenna
				2658361	E socket adaptor (for EW, ZW)
Notes					
CS: Canada, US: U.S.A., EW: Asia & Latin American countries, ZW: W. Germany, SA: Australia, BS: U.K., VK: Switzerland & Sweden					

FRONT AND REAR PANEL · VORDERE UND HINTERE BEDIENUNGSTAFEL ·
PANNEAUX AVANT ET ARRIERE

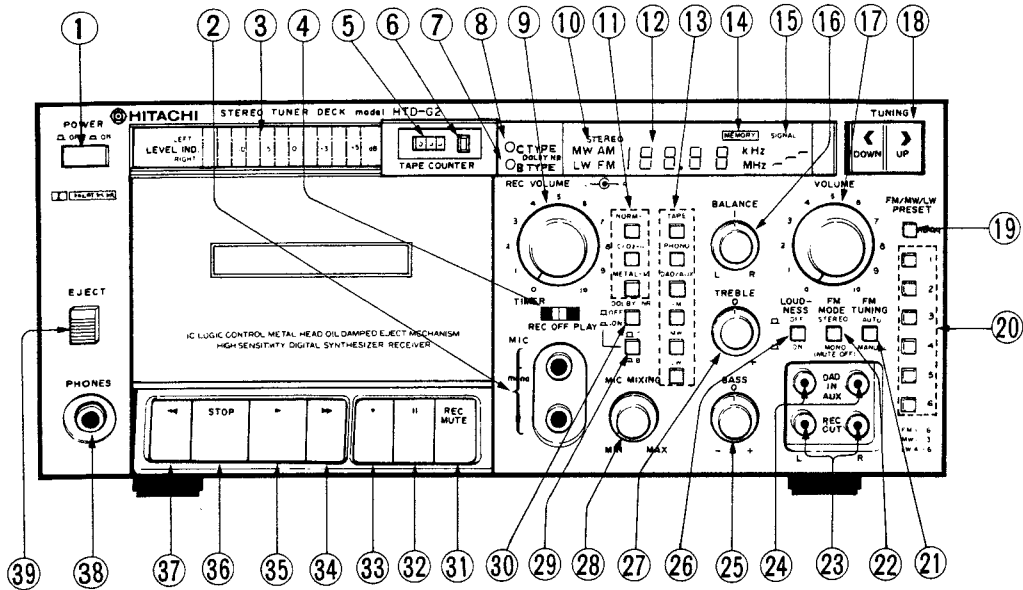

- ① POWER switch
- ② Microphone jacks
- ③ Level indicator
- ④ TIMER switch
- ⑤ Tape counter
- ⑥ Counter reset button
- ⑦ DOLBY B NR indicator
- ⑧ DOLBY C NR indicator
- ⑨ Record level control
- ⑩ FM STEREO indicator
- ⑪ Tape selector switches
- ⑫ Frequency display
- ⑬ FUNCTION switches
- ⑭ MEMORY indicator
- ⑮ SIGNAL indicators
- ⑯ BALANCE control
- ⑰ VOLUME control
- ⑱ TUNING button
- ⑲ MEMORY button
- ⑳ PRESET button
- ㉑ FM TUNING mode switch
- ㉒ FM MODE switch
- ㉓ REC OUT jacks
- ㉔ DAD/AUX input jacks
- ㉕ BASS control
- ㉖ LOUDNESS switch
- ㉗ TREBLE control
- ㉘ Mic mixing volume control
- ㉙ DOLBY B/C NR selector switch
- ㉚ Dolby NR switch
- ㉛ REC MUTE button
- ㉜ Pause button
- ㉝ Record button
- ㉞ Fast forward button
- ㉟ Playback button
- ㊱ STOP button
- ㊲ Rewind button
- ㊳ Headphone jack
- ㊴ EJECT button

- ① Netzschalter (POWER)
- ② Mikrofonbuchsen
- ③ Pegelanzeige
- ④ Timerschalter (TIMER)
- ⑤ Bandzählwerk
- ⑥ Bandzählwerk-Rückstellaste
- ⑦ Dolby-B-Rauschunterdrückungsanzeige (DOLBY B NR)
- ⑧ Dolby-C-Rauschunterdrückungsanzeige (DOLBY C NR)
- ⑨ Aussteuerungspegelregler
- ⑩ UKW-Stereoanzeige (FM STEREO)
- ⑪ Bandsortenwahlschalter
- ⑫ Frequenzanzeige
- ⑬ Funktionsschalter (FUNCTION)
- ⑭ Speicheranzeige (MEMORY)
- ⑮ Feldstärkeanzeigen (SIGNAL)
- ⑯ Balanceregler (BALANCE)
- ⑰ Lautstärkeregler (VOLUME)
- ⑱ Abstimmtaste (TUNING)
- ⑲ Speichertaste (MEMORY)
- ⑳ Vorwahltaste (PRESET)
- ㉑ UKW-Abstimmbetriebsartenschalter (FM TUNING)
- ㉒ UKW-Betriebsartenschalter (FM MODE)
- ㉓ Aufnahme-Ausgangsbuchsen (REC OUT)
- ㉔ Eingangsbuchsen für Digital-Plattenspieler und Zusatzgeräte (DAD/AUX)
- ㉕ Baßregler (BASS)
- ㉖ Schalter für gehörhörige Lautstärkekontur (LOUDNESS)
- ㉗ Höhenregler (TREBLE)
- ㉘ Lautstärkeregler für Mikrofonmischen
- ㉙ Dolby-B/C-Wahlschalter (DOLBY B/C NR)
- ㉚ Dolby Rauschunterdrückungsschalter (NR)
- ㉛ Taste für Aufnahme-Muting (REC MUTE)
- ㉜ Pausentaste
- ㉝ Aufnahmetaste
- ㉞ Schnellvorlauftaste
- ㉟ Wiedergabetaste
- ㊱ Stoppaste (STOP)
- ㊲ Rückspultaste
- ㊳ Kopfhörerbuchse
- ㊴ Auswurfaste (EJECT)

- ① Interrupteur d'alimentation (POWER)
- ② Prises de microphone
- ③ Indicateur de niveau
- ④ Commutateur de programmeur (TIMER)
- ⑤ Compteur de bande
- ⑥ Bouton de remise à zéro du compteur
- ⑦ Indicateur de Dolby NR B
- ⑧ Indicateur de Dolby NR C
- ⑨ Commande de niveau d'enregistrement
- ⑩ Indicateur FM STEREO
- ⑪ Sélecteurs de bande
- ⑫ Affichage de fréquence
- ⑬ Commutateurs de fonction (FUNCTION)
- ⑭ Indicateur de mémoire (MEMORY)
- ⑮ Indicateurs de SIGNAL
- ⑯ Commande d'équilibrage (BALANCE)
- ⑰ Commande de VOLUME
- ⑱ Bouton d'accord (TUNING)
- ⑲ Bouton de mémoire (MEMORY)
- ⑳ Bouton de prééglage (PRESET)
- ㉑ Commutateur de mode d'accord FM (FM MODE)
- ㉒ Commutateur de mode FM (FM MODE)
- ㉓ Prises de sortie d'enregistrement (REC OUT)
- ㉔ Prises d'entrée de disque audio numérique/auxiliaire (DAD/AUX)
- ㉕ Commande des graves (BASS)
- ㉖ Commutateur de correction physiologique (LOUDNESS)
- ㉗ Commande des aigus (TREBLE)
- ㉘ Commande de volume de mixage de microphone
- ㉙ Sélecteur du Dolby NR B/C
- ㉚ Commutateur du Dolby NR
- ㉛ Bouton de silencieux d'enregistrement (REC MUTE)
- ㉜ Bouton de pause
- ㉝ Bouton d'enregistrement
- ㉞ Bouton d'avance rapide
- ㉟ Bouton de lecture
- ㊱ Bouton d'arrêt (STOP)
- ㊲ Bouton de rebobinage
- ㊳ Prise de casque
- ㊴ Bouton d'éjection (EJECT)

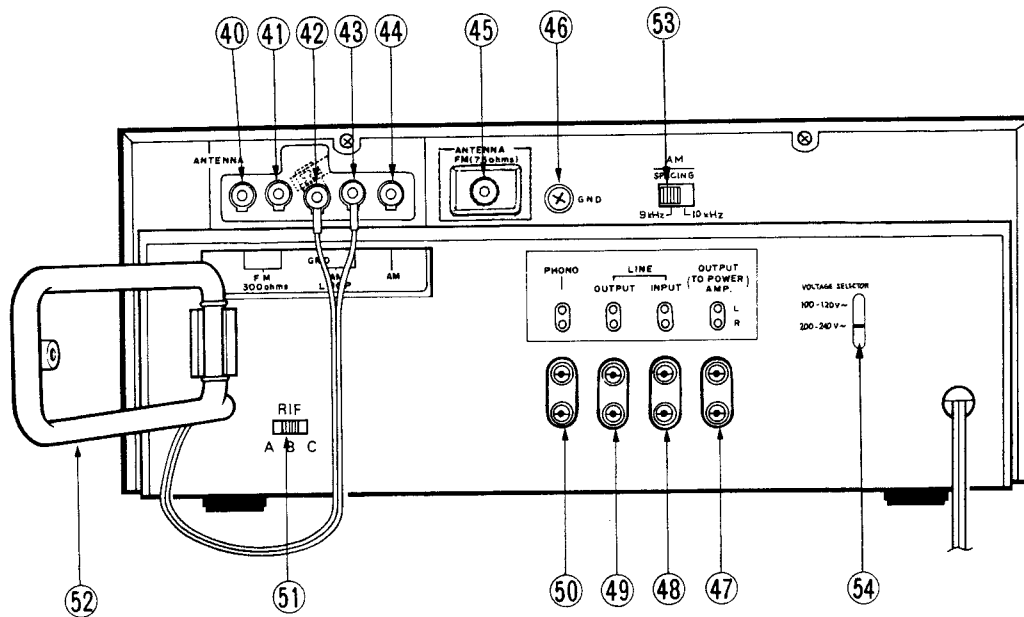

- ④① FM ANTENNA terminals (300 ohms)
- ④② AM LOOP antenna terminals
- ④④ AM EXTERNAL ANTENNA terminal
- ④⑤ FM ANTENNA jack (75 ohms)
(Switzerland, Sweden, U.K., Australia & W. Germany)
- ④⑥ Ground terminal
- ④⑦ OUTPUT jacks (to power amplifier)
- ④⑧ LINE INPUT jacks
- ④⑨ LINE OUTPUT jacks
- ⑤⑩ PHONO INPUT jacks
- ⑤⑪ RIF switch
- ⑤⑫ AM LOOP antenna
- ⑤⑬ AM (MW) spacing selector switch
(U.S.A., Canada, W. Germany, Asia & Latin American countries)
- ⑤⑭ Voltage selector switch
(W. Germany, Asia & Latin American countries)

- ④① UKW-Antennenklammern
(300 Ohm) (FM ANTENNA)
- ④② AM-Rahmenantennenklammern
(AM LOOP)
- ④④ AM-Außenantennenklemme
(AM EXTERNAL ANTENNA)
- ④⑤ UKW-Dipolantennenbuchse (75 Ohm)
(FM ANTENNA)
(Die Schweiz, Schweden, England, Australien, und Westen-Deutschland)
- ④⑥ Erdungsklemme
- ④⑦ Ausgangsbuchsen
(an Leistungsverstärker) (OUTPUT)
- ④⑧ Direkteingangsbuchsen
(LINE INPUT)
- ④⑨ Direktausgangsbuchsen
(LINE OUTPUT)
- ⑤⑩ Plattenspieler-Eingangsbuchsen
(PHONO INPUT)
- ⑤⑪ Schalter zum Unterdrücken von Interferenz-
zeifen (RIF)
- ⑤⑫ AM-Rahmenantenne (AM LOOP)
- ⑤⑬ AM (MW)- Abstandwählschalter
(USA, Kanada, West-Deutschland, Asien und
Lateinamerika)
- ⑤⑭ Spannungswählschalter
(West-Deutschland, Asien und Lateinamerika)

- ④① Bornes d'antenne FM
(FM ANTENNA) (300 ohms)
- ④② Bornes d'antenne-cadre AM
(AM LOOP)
- ④④ Borne d'antenne AM extérieure
(AM EXTERNAL ANTENNA)
- ④⑤ Prise d'antenne FM
(FM ANTENNA) (75 ohms)
(La Suisse, la Suède, le Royaume-Uni, l'Australie,
et l'Allemagne de l'Ouest)
- ④⑥ Borne de terre
- ④⑦ Prises de sortie (OUTPUT)
(vers l'amplificateur de puissance)
- ④⑧ Prises d'entrée de ligne
(LINE INPUT)
- ④⑨ Prises de sortie de ligne
(LINE OUTPUT)
- ⑤⑩ Prises d'entrée phono
(PHONO INPUT)
- ⑤⑪ Commutateur RIF
- ⑤⑫ Antenne-cadre AM
(AM LOOP ANTENNA)
- ⑤⑬ Commutateur sélecteur d'étendu de Modula-
tion d'amplitude (MW)
(Les Etats-Unis, Canada, l'Allemagne de
l'Ouest, l'Asie et les pays d'Amérique Latin)
- ⑤⑭ Commutateur sélecteur de Voltage
(L'Allemagne de l'Ouest, l'Asie et les Pays
d'Amérique Latin)

Check that exposed parts are acceptably insulated from the supply circuit before returning the instrument repaired to the customer.

● **Checking method**

Power switch is set to ON.
Next, measure the resistance value between the both poles of attachment cup (Power supply plug) and the exposed parts (Parts such as Ground terminal, knobs, Cover, etc. where the customer is easy to touch.) and check that the resistance value is 500 kohms or more.

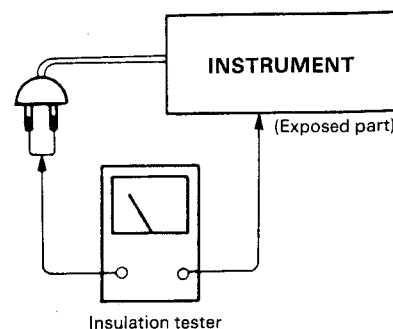



HITACHI SALES CORPORATION OF AMERICA

Eastern Regional Office

1200 Wall Street West, Lyndhurst, New Jersey 07071
Tel. 201-935-8980

Mid-Western Regional Office

1400 Morse Ave., Elk Grove Village, Ill. 60007
Tel. 312-593-1550

Southern Regional Office

510 Plaza Drive College Park, Georgia 30349
Tel. 404-763-0360

Western Regional Office

401 West Artesia Boulevard, Compton, California
90220
Tel. 213-537-8383

**HITACHI SALES CORPORATION OF HAWAII,
INC**

3219 Koapaka Street Honolulu, Hawaii
96819, U.S.A. Tel. 808-836-3621

HITACHI (HSC) CANADA INC.

3300 Trans Canada Highway Pointe Claire, Quebec
H9R1B
Tel. 514-697-9150

HITACHI SALES EUROPA GmbH

2050 Hamburg 54, Rungedamm 2, West Germany
Tel. 73411-0

HITACHI SALES (U.K.) Ltd.

Hitachi House, Station Road, Hayes, Middlesex UB3
4DR

Tel. 01-848-8787 (Service Centre: 01-848-3551)

HITACHI SALES SCANDINAVIA AB

Rissneleden 8, Sundbyberg, Box 7138, S-172-07
Sundbyberg 7, Sweden
Tel. 08-98 52 80

HITACHI SALES NORWAY A/S

Oerebekk 1620 Gressvik P.O. Box 46 N-1601
Fredrikstad, Norway
Tel. 032-28050

SUOMEN HITACHI OY

Box. 151, SF-15100 Lahti 10, Finland
Tel. Lahti 44 241

HITACHI SALES A/S

Kuldysen 13, DK-2630 Taastrup, Denmark
Tel. 02-999200

HITACHI SALES A.G.

5600 Lenzburg, Switzerland
Tel. 064-513621

HITACHI-FRANCE S.A.

97/115 Rue Charles-Michels 93200 SAINT-DENIS
Tel. 201-25-00

HITACHI SALES WARENHANDELS GMBH

A-1180/Wien, Kreuzgasse 27
Tel. (0043222) 439367/8

HITACHI SALES AUSTRALIA Pty Ltd.

153 Keys Road, Moorabbin, Victoria 3189 Australia
Tel. 95-8722

HITACHI Ltd. TOKYO JAPAN

Head Office: 5-1, 1-chome, Marunouchi, Chiyodaku,
Tokyo 100, Japan

Tel. Tokyo (212) 1111

Cable Address: "HITACHY" TOKYO

HTD-G2 TY No. 317 EGF