

HITACHI SERVICE MANUAL

TY

No. 563EF

MD18	(HRD-MD18 HT-MD28)	ES, BS, ZS, AU, EW
	MD28	(HRD-MD28 HT-MD28)

HRD-MD18

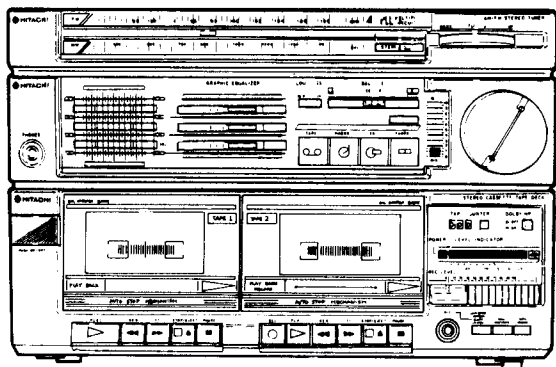

HRD-MD28

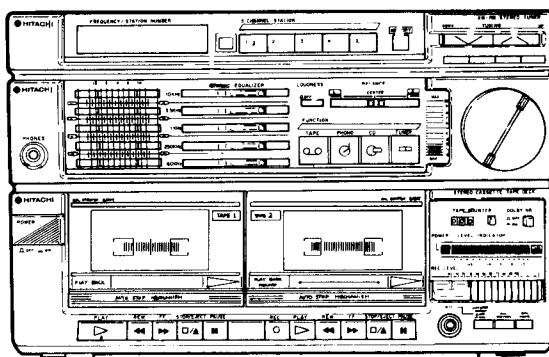

HT-MD28

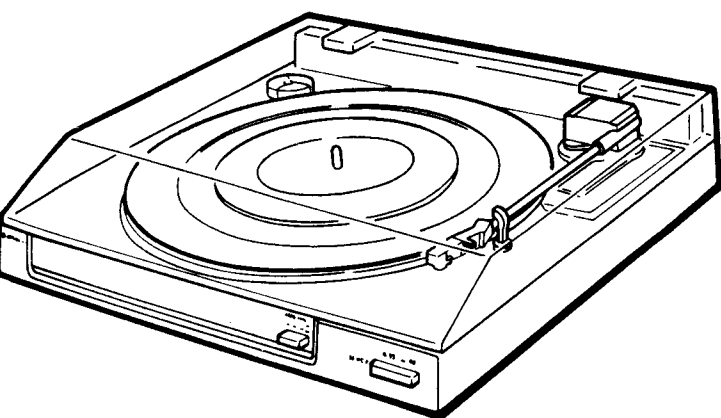

CONTENTS

KEY TO ILLUSTRATIONS	2
SPECIFICATIONS	4
DISASSEMBLY	7
DIAL CORD STRINGING	9
ADJUSTMENT	10
INSPECTION OF MECHANISM	18
LUBRICATION	20
CIRCUIT DIAGRAM	21
PRINTED WIRING BOARD	26
BLOCK DIAGRAM	33
EXPLODED VIEW	35
REPLACEMENT PARTS LIST	39

TABLE DES MATIERES

LEGENDES DES ILLUSTRATIONS	2
FICHE TECHNIQUE	5
DEMONTAGE	7
ENFILAGE DU CABLE DE CADRAN	9
REGLAGE	10
INSPECTION DU MECANISME	18
LUBRIFICATION	20
DIAGRAMME DES CIRCUITS	21
PLAN DE BASE	26
DIAGRAMME SYNOPTIQUE	33
VUE ECLATEE	35
LISTE DES PIECES DE RECHANGE	39

SPECIFICATIONS AND PARTS ARE SUBJECT TO CHANGE FOR IMPROVEMENT.

STEREO TUNER-AMPLIFIER DOUBLE CASSETTE RECORDER

July 1987

TOYOKAWA WORKS

KEY TO ILLUSTRATIONS · LEGENDES DES ILLUSTRATIONS

HRD-MD18

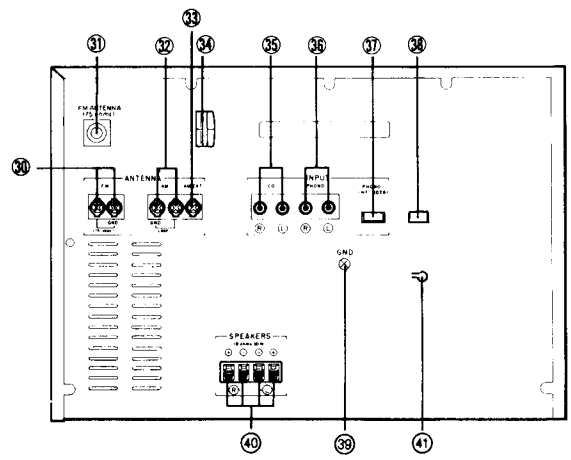
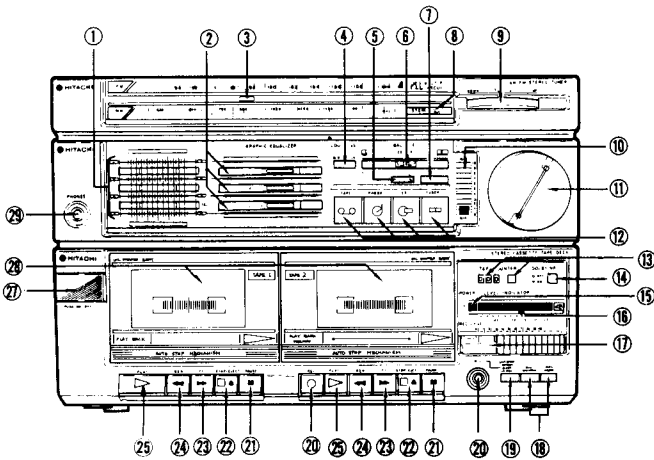

- | | |
|--------------------------------|--|
| 1 Graphic equalizer indicators | 26 Recording button (○) |
| 2 Graphic equalizer controls | 27 Power switch |
| 3 Dial pointer | 28 Cassette holders |
| 4 Loudness switch | 29 Headphone jack |
| 5 MW/LW selector | 30 FM antenna (aerial) terminals (75 ohms) |
| 6 Balance control | 31 FM antenna (aerial) socket (75 ohms) |
| 7 FM/AM selector | 32 AM loop antenna terminals |
| 8 FM stereo indicator | 33 AM external antenna terminal |
| 9 Tuning control | 34 AM loop antenna holder |
| 10 Volume indicator | 35 CD input jacks |
| 11 Volume control | 36 PHONO input jacks |
| 12 Function selector | 37 PHONO terminal (for HT-MD28 only) |
| 13 Tape counter/Reset button | 38 Radio interference frequency (RIF) cancel switch (for BS, ES) |
| 14 Dolby NR switch | 39 Radio terminal |
| 15 Power indicator | 40 Speaker terminals |
| 16 Level indicator | 41 Voltage selector switch (for EW) |
| 17 Record level control | |
| 18 Tape selector | |
| 19 High speed dubbing switch | |
| 20 Microphone jack | |
| 21 Pause button (■) | |
| 22 Stop/Eject button (□▲) | |
| 23 Fast forward button (▶▶) | |
| 24 Rewind button (◀◀) | |
| 25 Playback button (▷) | |

- | | |
|---|---|
| 1 Voyants de l'égaliseur graphique | 22 Touche d'arrêt/éjection (Stop/eject) (□ ▲) |
| 2 Commandes de l'égaliseur graphique | 23 Touche d'avancée rapide (▶▶) |
| 3 Indicateur à cadran | 24 Touche de rembobinage rapide (◀◀) |
| 4 Commutateur de compensation physiologique | 25 Touche de reproduction (▷) |
| 5 Sélecteur PO/GO | 26 Touche d'enregistrement (○) |
| 6 Commande de balance | 27 Commutateur d'alimentation |
| 7 Sélecteur MF/MA | 28 Compartiments à cassette |
| 8 Voyant stéréo MF | 29 Prise de casque |
| 9 Commande de syntonisation | 30 Bornes de l'antenne MF (75 ohms) (sauf pour ZS) |
| 10 Voyant du volume | 31 Emboîture de l'antenne MF (75 ohms) |
| 11 Commande du volume | 32 Bornes de l'antenne boucle MA |
| 12 Sélecteur de fonction | 33 Borne de l'antenne MA extérieure |
| 13 Compteur de bande/touche de remise à zéro | 34 Support de l'antenne boucle MA |
| 14 Commutateur de réduction de bruit Dolby NR | 35 Prises d'entrée CD (disques compacts) |
| 15 Voyant d'alimentation | 36 Prises d'entrée PHONO |
| 16 Voyant de niveau | 37 Borne PHONO (pour le HT-MD28 seulement) |
| 17 Commande du niveau d'enregistrement | 38 Commutateur d'annulation de fréquences radio parasites (RIF) (pour BS, ES) |
| 18 Sélecteur de bande | 39 Borne à la terre |
| 19 Commutateur pour le copiage rapide | 40 Bornes des haut-parleurs |
| 20 Prise de microphone | 41 Sélecteur de tension (pour EW) |
| 21 Touche de pause (■) | |

HRD-MD28

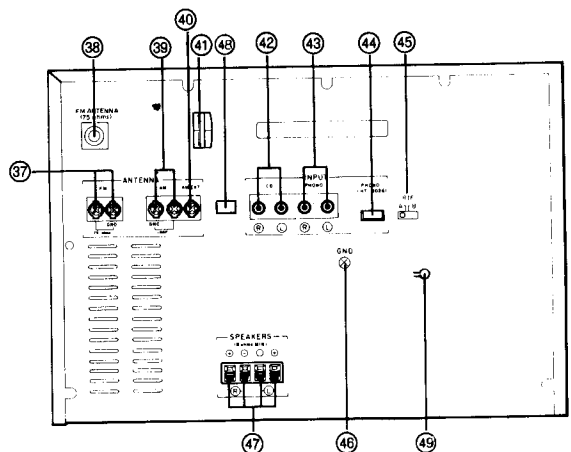
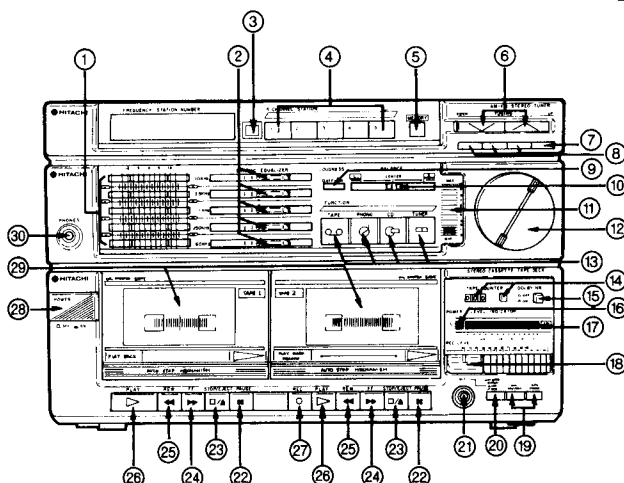
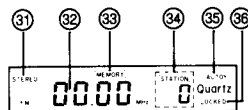

ES]

only)

- | | | | |
|-----------------------------------|---|---|---|
| 1 Graphic equalizer indicators | 29 Cassette holders | 41 Voyants de l'égaliseur graphique | 25 Touche de rembobinage rapide (◀◀) |
| 2 Graphic equalizer controls | 30 Headphones jack | 42 Commandes de l'égaliseur graphique | 26 Touche de reproduction (▷) |
| 3 Shift key (for BS, ES (France)) | 31 FM stereo indicator | 43 Touche d'alternance (pour BS, ES (France)) | 27 Touche d'enregistrement (○) |
| 4 Station keys | 32 Frequency display | 44 Touches de station | 28 Commutateur de mise sous tension |
| 5 Memory write key | 33 Memory indicator | 45 Touche d'écriture en mémoire | 29 Compartiments à cassette |
| 6 Tuning keys | 34 Station display | 46 Touches de syntonisation | 30 Prise de casque |
| 7 FM mode key | 35 FM mode "Auto" indicator | 47 Touche de mode MF | 31 Voyant MF stereo |
| 8 Band selector | 36 Locked indicator | 48 Sélecteur de gamme | 32 Affichage des fréquences |
| 9 Loudness switch | 37 FM antenna (aerial) terminals (75 ohms) (except ZS) | 49 Commutateur de compensation physiologique | 33 Voyant de la mémoire |
| 10 Balance control | 38 FM antenna (aerial) jack (75 ohms) | 50 Commande de la balance | 34 Affichage des stations |
| 11 Volume indicator | 39 AM loop antenna terminals | 51 Voyant du volume | 35 Voyant "Auto" du mode MF |
| 12 Volume control | 40 AM external antenna terminal | 52 Commande du volume | 36 Voyang "Locked" (verrouillé) |
| 13 Function selector | 41 AM loop antenna holder | 53 Sélecteur de fonction | 37 Bornes de l'antenne MF (75 ohms) (sauf ZS) |
| 14 Tape counter/Reset button | 42 CD input jacks | 54 Compteur de bande/touche de remise à zéro | 38 Prise de l'antenne MF (75 ohms) |
| 15 Dolby NR switch | 43 PHONO input jacks | 55 Commutateur de réduction de bruit Dolby NR | 39 Bornes de l'antenne boucle MA |
| 16 Power indicator | 44 PHONO terminal (For HT-MD28 only) | 56 Voyant d'alimentation | 40 Borne de l'antenne extérieure MA |
| 17 Level indicator | 45 Radio interference frequency (RIF) cancel switch (for BS, US, ES, ES (France)) | 57 Voyant du niveau | 41 Support de l'antenne boucle MA |
| 18 Record level control | 46 Ground terminal | 58 Commande du niveau d'enregistrement | 42 Prise d'entrée CD (lecteur disques compacts) |
| 19 Tape selector | 47 Speaker terminals | 59 Sélecteur de bande | 43 Prises d'entrée PHONO (pour HT-MD28 seulement) |
| 20 High speed dubbing switch | 48 AM spacing selector (for EW) | 60 Commutateur pour le copiage rapide | 44 Borne PHONO (pour HT-MD28 seulement) |
| 21 Microphone jack | 49 Voltage selector (for EW) | 61 Prise de microphone | 45 Commutateur d'annulation des fréquences radio parasites (RIF) (pour BS, VS, ES, ES (France)) |
| 22 Pause button (⏸) | | 62 Touche de pause (⏸) | 46 Borne à la terre |
| 23 Stop/Eject button (⏹) | | 63 Touche d'arrêt/éjection (Stop/eject) (⏹) | 47 Bornes des haut-parleurs |
| 24 Fast forward button (▶▶) | | | 48 Sélecteur de compensation MA (pour EW) |
| 25 Rewind button (◀◀) | | | 49 Sélecteur de tension (pour EW) |
| 26 Playback button (▷) | | | |
| 27 Recording button (○) | | | |
| 28 Power switch | | | |

HT-MD28

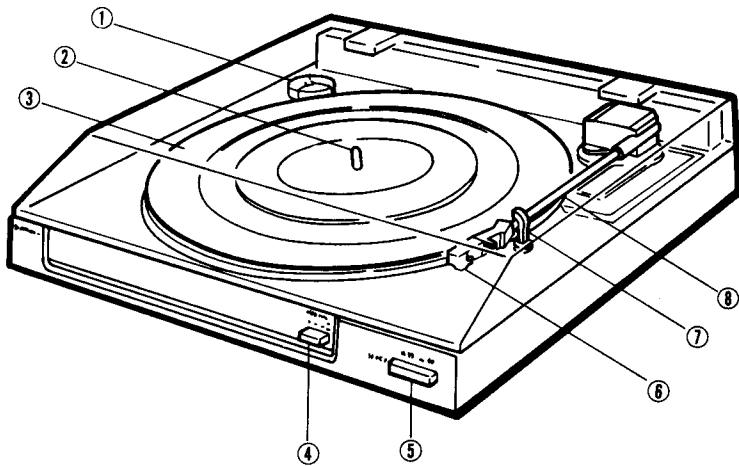

- | | |
|-----------------------|-------------------------------------|
| 1 45 rpm Adaptor | 1 Adaptateur 45 tours |
| 2 Disc guide | 2 Guide du disque |
| 3 Platter | 3 Plateau |
| 4 Cueing button | 4 Touche de repérage |
| 5 Speed select button | 5 Touche de sélection de la vitesse |
| 6 Stylus | 6 Pointe de lecture |
| 7 Arm rest | 7 Support du bras |
| 8 Tonearm | 8 Bras |

Check that exposed parts are acceptably insulated from the supply circuit before returning the instrument repaired to the customer.

● **Checking method**

Power switch is set to ON.

Next, measure the resistance value between the both poles of attachment cup (Power supply plug) and the exposed parts (Parts such as Ground terminal, Knob, Cover, etc. where the customer is easy to touch) and check that the resistance value is 500 kohms or more.

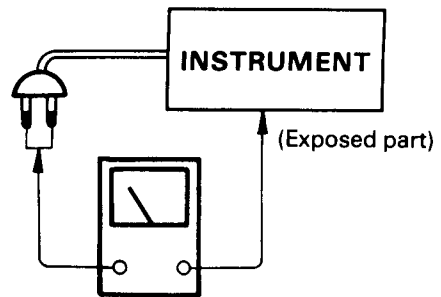

Insulation tester (DC500V)

SAFETY PRECAUTION

The following precautions should be observed when servicing.

1. Since many parts in the unit have special safety-related characteristics, always use genuine Hitachi's replacement parts. Especially critical parts in the power circuit block should not be replaced with other makers. Critical parts are marked with Δ in the circuit diagram and printed wiring board.
2. Before returning a repaired unit to the customer, the service technician must thoroughly test the unit to ascertain that it is completely safe to operate without danger of electrical shock.

SPECIFICATIONS

GENERAL SPECIFICATIONS

Power Supply: AC120V, 60Hz [For US, CS]
AC220V, 50Hz [For KS, ZS, VS, ES, ES (France)]
AC240V, 50Hz [For BS, AU]
AC120V/220V/240V, 50/60 Hz [For EW]

Power Consumption:

HRD-MD18

95W [For BS]
180W [For KS, ES, ZS, AU, EW]

HRD-MD28

145W [For US, CS]
180W [For BS, KS, ES, ES(France), ZS, VS, AU, EW]

Dimensions: 370 (W) x 246 (H) x 264 (D) mm
[14-9/16"(W) x 9-11/16" (H) x 10-3/8" (D)]

Weight: 7.0 kg (15 lbs. 6 oz.)

AMPLIFIER SECTION

HRD-MD18 (BS)

Audio Output: 15W x 2 (8 ohms, T.H.D. 5% both channel driven, 1 kHz)

Music Power Output: 30W x 2 (8 ohms, 1 kHz)

HRD-MD18 (KS, ES, ES (France) ZS, SA, EW)

HRD-MD28

Audio Output: 30 watts* per channel, min. RMS, at 8 ohms from 100 Hz to 10 kHz, with more than 2% total harmonic distortion.

30W x 2 (8 ohms, T.H.D. 5% both channel driven, 1 kHz)

Music Power Output: 60W x 2 (8 ohms, 1 kHz) [Except US]

Tone Control:

100 Hz \pm 8 dB	}	[HRD-MD18]
1 kHz \pm 8 dB		
10 kHz \pm 8 dB	}	[HRD-MD28]
63 Hz \pm 8 dB		
250 Hz \pm 8 dB		
1 kHz \pm 8 dB		
4 kHz \pm 8 dB		
16 kHz \pm 8 dB		

HRD-MD18/28

Input Sensitivity and Impedance: PHONO 3.5 mV/50 kohms
CD 150 mV/50 kohms
MIC 1mV/4 kohms

Output Impedance: Speaker: 8 ~ 16 ohms
Headphones: 8 ohms

TUNER SECTION

HRD-MD18

Circuit System: FM/AM 2-band [For KS, ZS, SA, EW]
FM/MW/LW 3-band superheterodyne [For BS, ES]

Tuning Range: FM: 87.5 to 108 MHz
AM (MW): 530 to 1605 kHz
LW: 150 to 285 kHz [For BS, ES]

IHF Sensitivity

FM: 5 μ V (S/N 26 dB)
AM (MW): 600 μ V/m (S/N 20 dB)
LW: 2,500 μ V/m (S/N 20 dB) [For BS, ES]

HRD-MD28

Circuit System: FM/AM 2-band digital synthesizer [For US, CS, KS, ZS, EW, SA]
FM/MW/LW 3-band superheterodyne [For BS, VS, ES, ES(France)]

Tuning Range: FM: 87.9 to 107.9 MHz [For US]
87.50 to 108.00 MHz [Except US]

AM: 530 to 1620 kHz [For US]
MW: 522 to 1611 kHz [Except US]
LW: 153 to 281 kHz [For BS, ES, ES(France), VS]

IHF Sensitivity:

FM: 1 μ V (S/N 30 dB) [For US, CS]
1 μ V (S/N 26 dB) [Except US, CS, ZS]
2 μ V (S/N 26 dB) [For ZS]
AM (MW): 600 μ V/m (S/N 20 dB)
LW: 2500 μ V/m (S/N 20 dB)
For [BS, ES (France), VS]

HRD-MD18/28

FM Stereo separation: 35 dB

FM S/N

(Signal to noise Ratio): 60 dB

Antennas:

FM: External antenna (aerial)
Power supply cord antenna [For US, CS]

AM (MW/LW): Loop antenna
Out door antenna

TAPE DECK SECTION

Cassette tape deck

Tape: Cassette tape
Tape speed: 4.75 cm/s (1-7/8")

Recording System and Bias Frequency: AC bias, 85 kHz

Track System: 4 track 2 channel

Erasing System: AC erase

Frequency Response: Normal: 70 Hz to 14 kHz
CrO₂: 70 Hz to 14 kHz
Metal: 70 Hz to 15 kHz (HRD-MD28 only)

Signal-to-Noise Ratio: Dolby ON: 58 dB
OFF: 50 dB

Crosstalk: 60 dB

Erase Ratio: 65 dB

Motor: DC Motor

SPEAKER SECTION (For SA, EW)

Unit: (16 cm woofer + 5 cm tweeter) x 2

Type: Bass-reflex type

Dimensions: 230 (W) x 363 (H) x 185 (D) mm

Weight: 2.8 kg x 2

Specifications and design may be changed without notice for improvement.

* Measured pursuant to the Federal Trade Commission's Trade Regulation Rule on Power Output Claims for Amplifiers.

HT-MD28

Type: 2-speed belt drive system

Platter: 295 mm diameter platter

Motor: DC motor

Speed: 2 speeds, 33-1/3 and 45 rpm

Signal to noise ratio: 56 dB (DIN-B)

Wow and Flutter: 0.07% (WRMS)

Tonearm:

Effective length: 205 mm

When a HITACHI cartridge is attached:

Cartridge: Moving Magnet

Output voltage: 2.5 mV

Crosstalk: 25 dB (1 kHz)

Load Impedance: 47 kohm 100 pF

Stylus tip: Diamond stylus

Power source: DC 12V (Secondary supply from HRD-MD 18 or HRD-MD28)

Power consumption: 3 watts

Dimensions: 370 (W) x 89 (H) x 340 (D) mm

Weight: 3 kg

PRECAUTIONS DE SECURITE

Les précautions suivantes doivent être observées chaque fois qu'une réparation est à faire.

- De nombreux composants de l'appareil répondant caractéristiquement aux normes de sécurité, utilisez toujours des pièces de rechange d'origine Hitachi. En particulier des pièces d'importance critique ne devront pas être remplacées par des pièces d'autres fabricants. Ces pièces critiques sont marquées du symbole — dans le schéma de montage et sur le schéma de plaques de câblage.
- Avant de redonner au client son appareil réparé, le technicien devra procéder à une vérification complète de l'appareil pour s'assurer qu'il ne présente aucun risque d'électrocution.

FICHE TECHNIQUE

GENERALITES

Alimentation: CA120V, 60Hz [pour US, CS]
CA220V, 50Hz [pour KS, ZS, VS, ES (France)]
CA240V, 50Hz [pour BS, AU]
CA120V/220V/240V, 50/60Hz [pour EW]

Consommation:

HRD-MD18 95W [pour BS]
180W [pour KS, ES, ZS, AU, EW, ES]

HRD-MD28 145W [pour US, CS]
189W [pour BS, KS, ES, ES (France), ZS, VS, AU, EW]

Dimensions: 370(L) x 246(H) x 264(P) mm

Poids: 7,0 kg

SECTION AMPLIFICATEUR

HRD-MD18 (BS)

Sortie audio: 15W x 2 (8 ohms, distorsion harmonique totale 5% sur les deux canaux, 1 kHz)

Sortie de puissance: 30W x 2 (8 ohms, 1 kHz)

HRD-MD18 (KS, ES, ES (France) ZS, SA, EW)

HRD-MD28

Sortie audio: 30 watts*/canal, min. RMS, à 8 ohms de 100 Hz à 10 Hz, avec plus de 2% de distorsion harmonique totale.
30W x 2 (8 ohms, distorsion harmonique totale 5% sur les deux canaux, 1 kHz)

Sortie de puissance de la musique: 60W x 2 (8 ohms, 1 kHz) [excepté US]

Commande des tonalités:

100 kHz±8 dB	[HRD-MD18]
1 kHz±8 dB	
10 kHz±8 dB	[HRD-MD28]
63 Hz±8 dB	
250 Hz±8 dB	
1 kHz±8 dB	
4 kHz±8 dB	
16 kHz±8 dB	

HRD-MD18/28

Sensibilité et impédance de sortie: PHONO 3,5 mV/50 kohms
CD: 150 mV/50 kohms
MIC: 1 mV/4 kohms
Haut-parleur: 8 ~ 16 ohms
Casque: 8 ohms

Impédance de sortie:

SECTION TUNER

HRD-MD18

Système de circuits:	MF/MA 2-gammes [pour KS, ZS, SA, EW] MF/PO/GO 3 gammes superhétérodyne [pour BS, ES]
Portée d'accord:	MF: 87,5 à 108 MHz MA(PO): 530 à 1605 kHz GO: 150 à 285 kHz [pour BS, ES]
Sensibilité IHF:	MF: 5 μ V (S/B 26 dB) MA (PO): 600 μ V/m (S/B 20 dB) GO: 2500 μ V/m (S/B 20 dB) [pour BS, ES]

HRD-MD28

Système de circuits:	MF/MA 2 gammes superhétérodyne [pour US, CS, KS, ZS, EW, SA] MF/PO/GO 3 gammes superhétérodyne [pour BS, VS, ES, ES (France)]
Portée d'accord:	MF: 87,9 à 107,9 MHz [pour US] 87,50 à 108,00 MHz [sauf US] MA: 530 à 1620 kHz [pour US] PO: 522 à 1611 kHz [sauf US] GO: 153 à 281 kHz [pour BS, ES (France), VS]
Sensibilité IHF:	MF: 1 μ V (S/B 30 dB) [pour US, CS] 1 μ V (S/B 26 dB) (sauf US, CS, ZS) 2 μ V (S/B 26 dB) [pour ZS] MA (PO): 600 μ V/m (S/B 20 dB) GO: 2500 μ V/m (S/B 20 dB) [pour BS, ES (France), VS]

HRD-MD18/28

Séparation stéréo MF:	35 dB
Rapport signal/bruit MF:	60 dB
Antennes:	MF: antenne extérieure Antenne à cordon secteur [pour US, CS] MA (PO/GO): Antenne à boucle Antenne extérie- ure

SECTION MAGNETOCASSEE

Magnétocassette

Bande:	Bande cassette
Vitesse de bande:	4,75 cm/s
Système d'enregistrement et fréquence de polarisation:	Polarisation, CA 85 kHz
Système de piste:	4 pistes, 2 canaux
Système d'effacement:	Effacement CA
Réponse en fréquence:	Normal: 70 Hz à 14 kHz Chrome: 70 Hz à 14 kHz Métal: 70 Hz à 15 kHz (HRD-MD 28 seulement)
Rapport signal/bruit:	Avec Dolby: 58 dB Sans Dolby: 50 dB
Transmodulation:	60 dB
Coefficient d'effacement:	65 dB
Moteur:	Moteur CC

SECTION HAUT-PARLEUR (POUR SA, EW)

Appareil:	(transducteur de graves 16 cm + transducteur d'aigües 5 cm) x 2
Type:	Bass-reflex
Dimension:	230(L) x 363(H) x 185(P) mm
Poids:	2,8 kg x 2

Aux fins d'améliorations, la fiche technique et l'aspect de ces produits sont susceptibles de modifications sans préavis.

*Mesuré conformément aux réglementations de la Federal Trade Commission relatives à la sortie de puissance devant être fournie par des amplificateurs.

HT-MD28

Type	Système 2 vitesses à commande par courroie
Plateau	Plateau de 295 mm de diamètre
Moteur	Moteur CC
Vitesse	2 vitesses, 33-1/3 et 45 tours
Rapport signal/bruit:	56 dB (DIN-B)
Pleur et scintillement	0,007%(WRMS)
Bras de lecture	
Longueur effective	205 mm
Lorsqu'une cellule Hitachi est incorporée	
Cellule	Aimant mobile
Tension de sortie	2,5 mV
Transmodulation	25 dB (1 kHz)
Impédance de charge	45 kohms 100 pF
Pointe de lecture	Diamant
Source d'alimentation	CC 12V (alimentation secondaire provenant de HRD-MD 18 ou HRD-MD 28)
Consommation	3 watts
Dimensions	370(L) x 89(H)x340(P) mm
Poids	3 kg

DISASSEMBLY

HRD-MD18

- 1. Removing the Upper Cover (Fig. 1)**
Remove the 6 mounting screws (A) and 3 mounting screws (B).
- 2. Removing the Rear Plate (Fig. 2)**
After removing the upper cover, remove the 4 mounting screws (C) and the 2 connectors of the FM antenna terminals. For EW version, remove the screw (R) moreover.
- 3. Removing the TD P.W.B. (Fig. 2)**
After removing the rear plate, remove the 6 mounting screws (D), screw (T), 10 connectors and 2 claws, then remove the LED P.W.B. and pull it toward you slightly.
(At the same time, the 4 FUNCTION knobs are also removed.)
Then proceed to the REC spring removal.
- 4. Removing the PA P.W.B. (Fig. 3)**
After removing the TD P.W.B., remove the 2 screws (F) and 2 screws (G) retaining the transformer and 2 screws (H) retaining the heat sink holder. Then remove the 3 connectors.
- 5. Removing the GE P.W.B. (Fig. 3)**
Remove the 6 mounting screws (I) to remove the GE P.W.B. after removing the pulley fixing screw (J) and the pulley.
Remove the REC wire and REC lever (B), before removing the GE P.W.B.
- 6. Removing the Cassette Chassis (Fig. 3)**
After removing the GE P.W.B., remove the cassette lid and 6 mounting screws (K).

DEMONTAGE

HRD-MD18

- 1. Retrait du couvercle supérieur (Fig. 1)**
Retirez les six vis de montage (A) et trois vis de montage (B).
- 2. Retrait de la plaque arrière (Fig. 2)**
Après avoir retiré le couvercle supérieur, retirez les quatre vis de montage (C) et les deux connecteurs des bornes de l'antenne MF. Pour la version EW, retirez également la vis (R).

HRD-MD28

- 1. Removing the Upper Cover (Fig. 1)**
Same as the HRD-MD18.
- 2. Removing the Rear Plate (Fig. 4)**
After removing the upper cover, remove the 4 mounting screws (L) and the connector of the FM antenna terminals. For EW version, remove the screw (S) moreover.
- 3. Removing the TD P.W.B. (Fig. 4)**
After removing the rear plate, remove the 6 mounting screws (M) and 9 connectors, and then pull the TD P.W.B. toward you slightly.
(At the same time, the 4 knobs are also removed.)
Then, proceed to the REC spring removal.
- 4. Removing the PA P.W.B. (Fig. 5)**
After removing the TD P.W.B., remove the 2 screws (N) and 2 screws (O) retaining the transformer, and the 2 screws (P) retaining the heat sink holder. Then remove the 3 connectors.
- 5. Removing the GE P.W.B. (Fig. 5)**
Remove the 9 mounting screws (Q).
Remove the REC wire and REC lever (B), before removing the GE P.W.B.
- 6. Removing the Cassette Chassis (Fig. 5)**
Same as the HRD-MD18.

HRD-MD28

- 1. Retrait du couvercle supérieur (Fig. 1)**
Même procédure que pour le HRD-MD18.
- 2. Retrait de la plaque arrière (Fig. 4)**
Après avoir retiré le couvercle supérieur, retirez les quatre vis de montage (L), et le connecteur des bornes de l'antenne MF. Pour la version EW, retirez également la vis (S).

3. Retrait de la PCI (plaquette de circuit imprimé) TD (Fig. 2)

Après avoir retiré la plaque arrière, retirez les six vis de montage (D), la vis (T), les dix connecteurs et les deux pattes, puis retirez la plaquette (P.C.I.) à diode LED et tirez-la légèrement vers vous.

(En même temps, vous retirerez les quatre boutons de fonction FUNCTION.)

Puis procédez au retrait du ressort d'enregistrement (REC).

4. Retrait de la P.C.I. PA (Fig. 3)

Après avoir retiré la P.C.I. TD, retirez les deux vis (E), et deux vis (G) qui maintiennent en place le transformateur, ainsi que deux vis (H) maintenant en place le support du puits de chaleur. Puis retirez les trois connecteurs.

5. Retrait de la P.C.I. GE (Fig. 3)

Retirez les six vis de montage (I) pour retirer la P.C.I. GE après avoir retiré la vis de fixation de la poulie de cadran (J) et la poulie elle-même.

Enlevez le câble d'enregistrement et le levier d'enregistrement (B) avant d'enlever la P.C.I. GE.

6. Retrait du coffret (Fig. 3)

Après avoir retiré la P.C.I. GE, retirez couvercle du compartiment à cassette et les six vis de montage (K).

3. Retrait de la P.C.I. TD (Fig. 4)

Après avoir retiré la plaque arrière, retirez les six vis de montage (M) et neuf connecteurs, puis tirez la P.C.I. légèrement vers vous.

(Au même moment, les quatre boutons de FONCTION sont également retirés.)

Puis procédez au retrait du ressort d'enregistrement (REC).

4. Retrait de la P.C.I. PA (Fig. 5)

Après avoir retiré la P.C.I. TD, retirez les deux vis (N) et les deux vis (O) maintenant en place le transformateur, ainsi que les deux vis (P) maintenant en place le support du puits de chaleur. Puis retirez les trois connecteurs.

5. Retrait de la P.C.I. GE (Fig. 5)

Retirez les neuf vis de montage (Q).

Enlevez le câble d'enregistrement et le levier d'enregistrement (B) avant d'enlever la P.C.I. GE.

6. Retrait du coffret (fig. 5)

Même procédure que pour le HRD-MD 18.

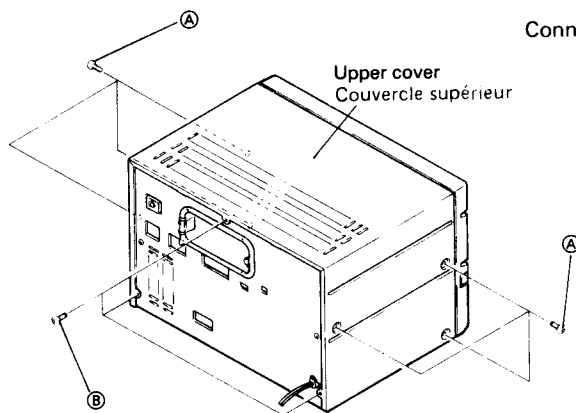

Fig. 1

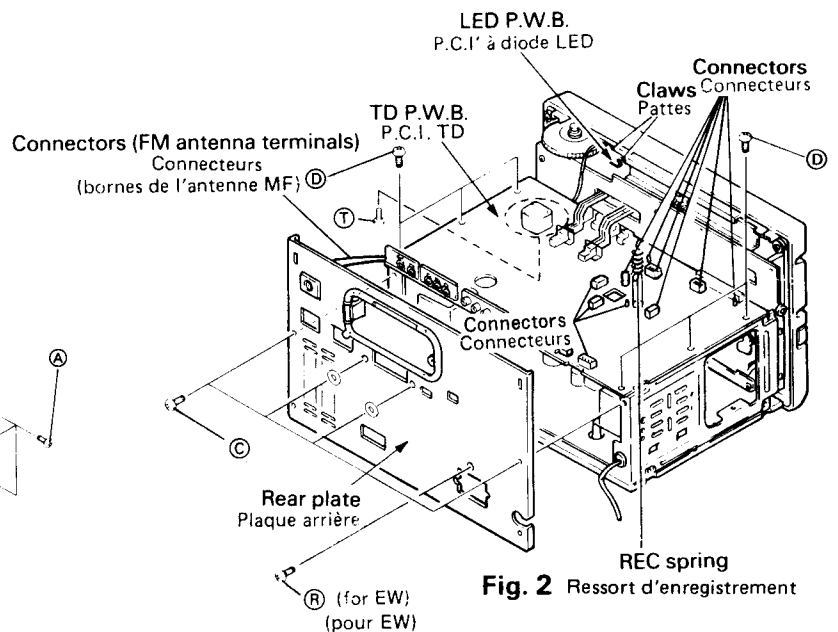
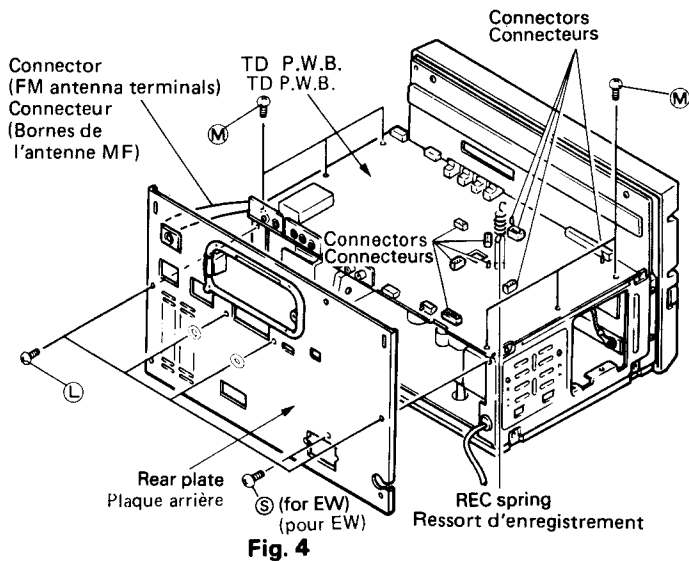
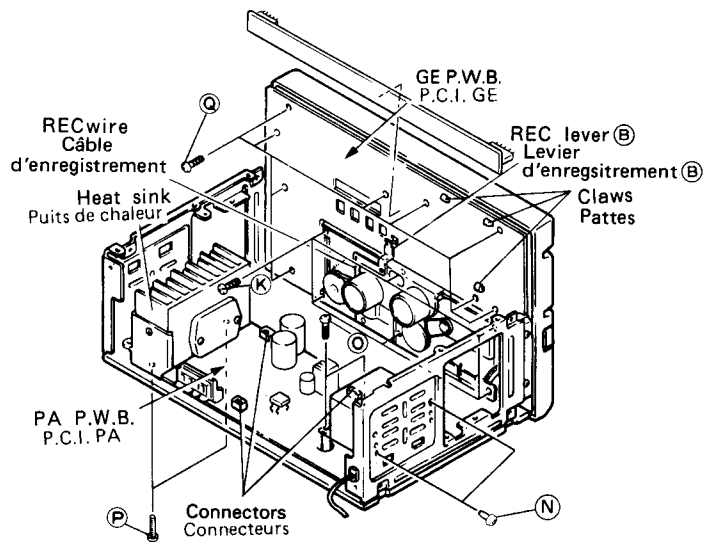
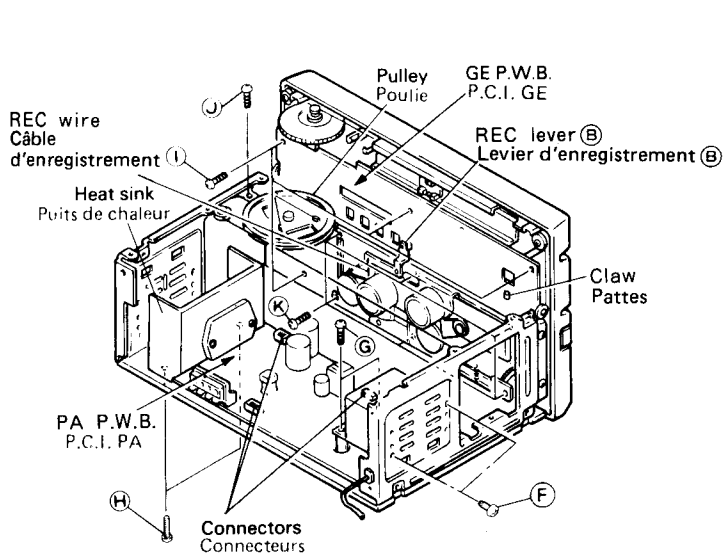

Fig. 2



DIAL CORD STRINGING

1. Rotate the tuning knob fully clockwise.
2. Thread the dial cord around the pulleys shown in the diagram in numerical order.

ENFILAGE DU CABLE DE CADRAN

1. Tournez le bouton de syntonisation à fond dans le sens des aiguilles d'une montre.
2. Enroulez le câble de cadran autour des poulies indiquées sur le diagramme dans leur ordre numérique.

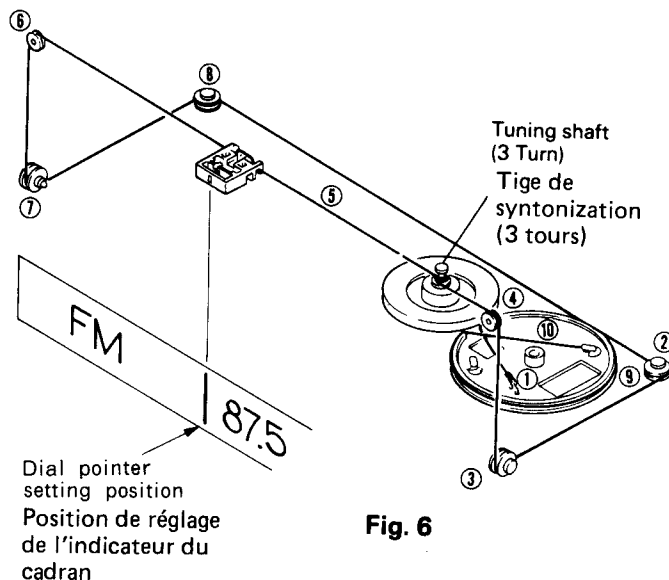

ADJUSTMENT · REGLAGE

1. RADIO SECTION SECTION RADIO

HRD-MD18

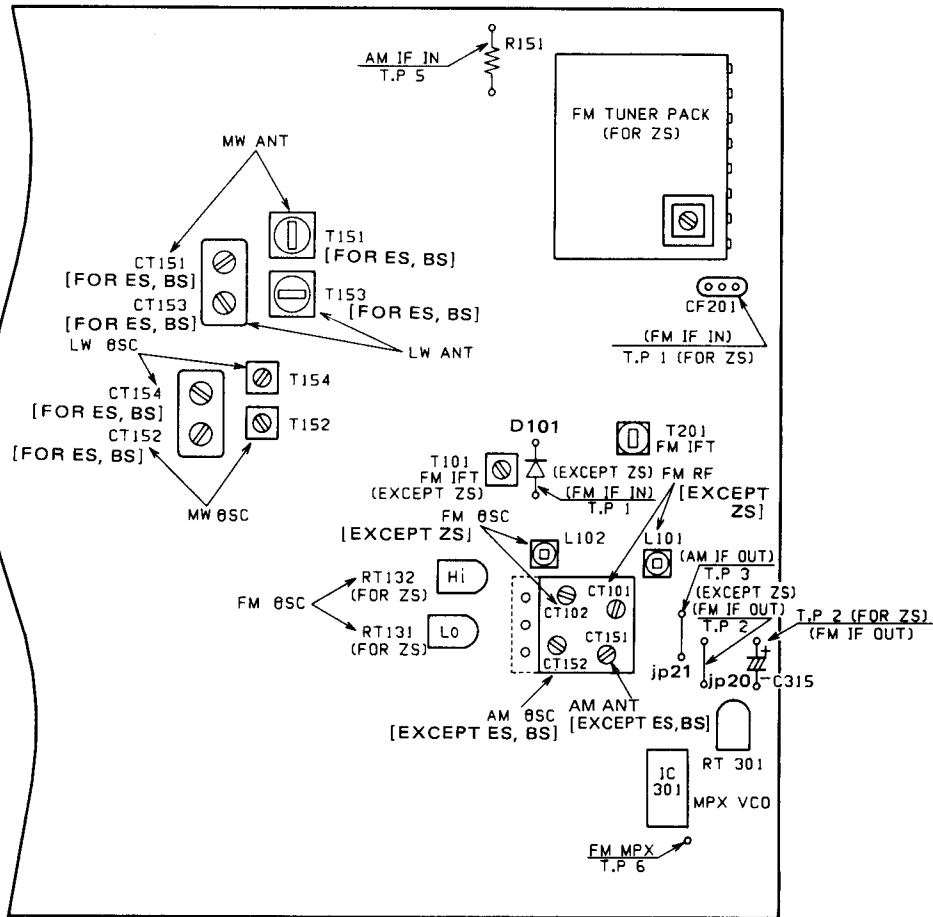

FM Section

Step	Adjustment Item	Measuring Instrument and Connection			Genescope or Signal Generator Frequency	Dial Pointer Position	Adjust	Reading	
		Measuring Instrument	Input Terminal	Output Terminal					
1	(1) FM IF	Genescope (10.7 MHz)	TP. 1	TP. 2	10.7 MHz	Highest	T101	Note 1	
	(2) S-Curve						T201	Note 2	
2	FM OSC (Covering)	<ul style="list-style-type: none"> ● FM signal generator (400 Hz, 30% dev.) ● Oscilloscope ● VTVM 	FM ANT 22.5 kHz DEV. 60dB	SP OUT	ZS	Lowest	RT131 (for ZS) L102	Max	
					Other				87.25±0.25 MHz
					Other	108.25±0.25 MHz	Highest		RT132 (for ZS) CT102
					Repeat steps (1) and (2)				
3 <small>except ZS</small>	FM ANT (Tracking)				90 MHz	90 MHz	L101	Max	
					106 MHz	106 MHz	CT101		
					Repeat steps (1) and (2)				
4	MPX VCO (19 kHz)	Frequency counter	FM ANT 22.5 kHz DEV. 60 dB Non modulation	Connect via 100 kΩ resistor	98 MHz	98 MHz	RT301	19 kHz ± 50 Hz	

Section MF

Etape	Poste de réglage	Instrument de mesure et connexion			Fréquence du gènescope ou du générateur de signaux	Position de l'indicateur du cadran	Réglez	Lecture	
		Instrument de mesure	Borne d'entrée	Borne de sortie					
1	(1) FM IF (Moyenne fréquence MF)	Gènescope (10,7 MHz)	TP. 1	TP. 2	10,7 MHz	Maximale (le plus haut possible)	T101	Remarque 1	
	(2) Courbe en S						T201	Remarque 2	
2	FM OSC (oscillateur MF) (guipage)	<ul style="list-style-type: none"> • Générateur de signaux MF (400 Hz, dév.) • Oscilloscope • VTVM (voltmètre électronique) 	FM ANT (antenne MF) 22,5 kHz dév. 60 dB	SP hors circuit (OUT)	ZS	87,4 +0,1 -0,15 MHz	Minimale (le plus bas possible)	RT 131 (pour ZS)	Max
					Autre	87,25 ± 0,25 MHz		L 102	
					(3)	Autre	108,25 ± 0,25 MHz	Maximale (le plus haut possible)	
Répétez les étapes (1) et (2)									
Sauf ZS 3	FM ANT (antenne MF) (alignement)				90 MHz		90 MHz	L101	Max
					106 MHz		106 MHz	CT101	
					Répétez les étapes (1) et (2)				
4	(1) MPX VCO (oscillateur à fréquence réglée par variation de tension MPX) (19 kHz)	Compteur de fréquences	FM ANT (antenne MF) 22,5 kHz dév. 60 dB non-modulation	Connectez par enregistreur 100 kohms 98 MHz	98 MHz	98 MHz	RT301	19 kHz ± 50 Hz	

Adjustment

Note 1: Using a sweep generator, input the weak signal (with a level causing noise on the IF waveform as shown in Fig. 6) so that the waveform becomes maximum and symmetrical.

Note 2: Generate the S-curve and adjust so that the A and B are symmetrical and linear as shown in Fig. 7.

Réglage

Remarque 1: A l'aide d'un générateur de balayage, introduisez le signal faible (à un niveau causant des parasites sur la forme d'onde intermédiaire (IF) comme le montre la figure 6), pour que la forme d'onde devienne maximum et symétrique.

Remarque 2: Générez la courbe en S et réglez de façon que les A et B soient symétrique et linéaires comme le montre la Fig. 7.

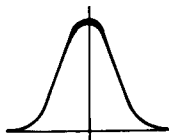

Fig. 6

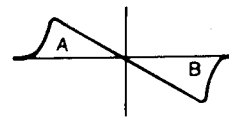

Fig. 7

AM Section

Step	Adjustment Item	Measuring Instrument and Connection			Gènescope or Signal Generator Frequency	Dial Pointer Position	Adjust	Reading	
		Measuring Instrument	Input Terminal	Output Terminal					
1	AM IF	Genescope (455 kHz)	TP. 5	TP. 3				Note 3	
2	MW OSC (Covering)	<ul style="list-style-type: none"> • AM signal generator (400 Hz, 30% mod.) • VTVM • Oscilloscope 	Loop antenna Note 4	SP. OUT	515 kHz	Lowest	T152	Max Note 4	
					1.650 kHz	Highest	CT152		
					Repeat steps (1) and (2)				
3	MW ANT (Tracking)				600 kHz	600 kHz	T151	Max Note 4	
					1.400 kHz	1.400 kHz	CT151		
					Repeat steps (1) and (2)				

4	(1)	LW OSC (Covering)	<ul style="list-style-type: none"> ● AM signal generator (400 Hz, 30% mod.) ● VTVM ● Oscilloscope 	Loop antenna Note 4	SP. OUT	145 kHz	Lowest	T154	Max Note 4			
	(2)					290 kHz	Highest	CT154				
	(3)					Repeat steps (1) and (2)						
5	(1)	LW ANT (Tracking)							160 kHz	160 kHz	T153	Note 4
	(2)								270 kHz	270 kHz	CT153	
	(3)											

Section MA

Etape	Poste de réglage	Instrument de mesure et connexion			Fréquence du gènescope ou du générateur de signaux	Position de l'indicateur du cadran	Réglez	Lecture				
		Instrument de mesure	Borne d'entrée	Borne de sortie								
1	(1)	AM IF (moyenne fréquence MA)	Gènescope (455 kHz)	TP. 5	TP. 3			Remarque 3				
	(2)											
2	(1)	MW OSC (oscillateur PO) (guipage)	<ul style="list-style-type: none"> ● Générateur de signaux MA (400 Hz, 30% de mod.) ● VTVM (voltmètre électronique) ● Oscilloscope 	Antenna à boucle Remarque 4	SP.OUT (hors circuit)	515 kHz	Le plus bas possible	T152	Max Remarque 4			
	(2)					1,650 kHz	Le plus haut possible	CT152				
						Répétez les étapes (1) et (2)						
3	(1)	MW ANT (antenne PO) (alignement)							600 kHz	600 kHz	T151	Max Remarque 4
	(2)								1,400 kHz	1,400 kHz	CT151	
(3)	Répétez les étapes (1) et (2)											
4	(1)	LW OSC (oscillateur GO) (guipage)							145 kHz	Le plus bas possible	T154	Max Remarque 4
	(2)								290 kHz	Le plus haut possible	CT154	
(3)	Répétez les étapes (1) to (2)											
5	(1)	LW ANT (antenne GO) (alignement)							160 kHz	160 kHz	T153	Remarque 4
	(2)								270 kHz	270 kHz	CT153	
(3)												

Note 3: If the signal from the sweep generator is weak, make sure that the waveform becomes maximum and symmetrical as shown in Fig. 8.

Raise the level of the sweep generator, make sure the range at point (A) becomes as flat as possible as shown in Fig. 9.

Note 4: Initially set the input level to 74 dB/m, and lower the level to minimum as required (approx. 60 dB/m) for progress of the adjustment. And adjust repeatedly so that the output is maximum at the specified frequency.

Remarque 3: Si le signal provenant du générateur de balayage est faible, assurez-vous que la forme d'onde devienne maximale et symétrique comme indiqué en figure 8. Augmentez le niveau du générateur de balayage et vérifiez que le parcours en point (A) est aussi plat que possible comme indiqué en figure 9.

Remarque 4: Placez d'abord le niveau d'entrée à 74 dB/m, et abaissez le niveau au minimum comme il vous l'est demandé (environ 60 dB/m) pour continuer le réglage. Réglez à plusieurs reprises jusqu'à ce que la sortie soit maximale à la fréquence spécifiée.

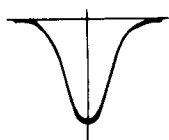

Fig. 8

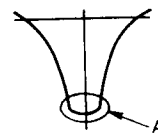
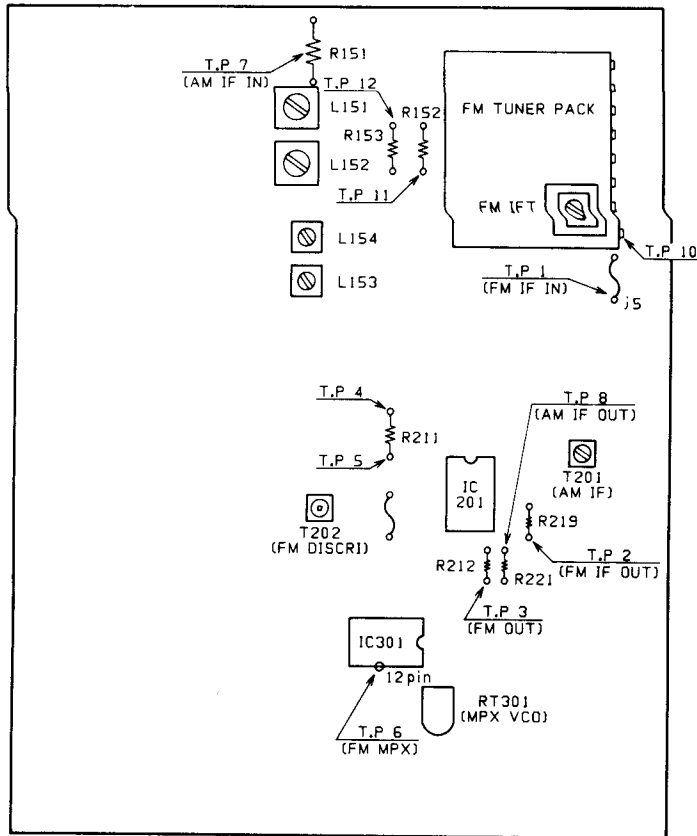

Fig. 9

HRD-MD28



FM Section

Step	Adjustment Item	Measuring Instrument and Connection			Genescope or Signal Generator Frequency	Dial Pointer Position	Adjust	Reading
		Measuring Instrument	Input Terminal	Output Terminal				
1	(1) FM IF	Genescope (10.7 MHz)	TP. 1	TP. 2	10.7 MHz		FM IFT	Note 5
	(2) S-Curve			TP. 3			—	Note 6
2	(1) Discriminator	DC balance meter	FM ANT 22.5 kHz DEV. 60 dB	TP. 4 TP. 5	98 MHz 98.1 MHz	98 MHz 98.1 MHz	T202	0 ± 10mV
3	(1) MPX VCO (19 kHz)		FM ANT 75 ohms 22.5 kHz DEV. 60 dB Non modulation	TP. 6 Connect via 100kΩ resistor	98 MHz 98.1 MHz	98 MHz 98.1 MHz	RT301	19 kHz ± 50 Hz

Section MF

Etape	Poste de réglage	Instrument de mesure et connexion			Fréquence du genescope ou générateur de signaux	Position de l'indicateur du cadran	Réglez	Lecture
		Instrument de mesure	Borne d'entrée	Borne de sortie				
1	(1) FM IF (moyenne fréquence MF)	Génescope (10,7 MHz)	TP. 1	TP. 2	10,7 MHz		MF IFT	Remarque 5
	(2) Courbe en S			TP. 3			—	Remarque 6
2	(1) Discriminateur	Mètre de balance CC	FM ANT (antenne MF) 22,5 kHz dév. 60 dB	TP. 4 TP. 5	98 MHz 98,1 MHz	98 MHz 98,1 MHz	T202	(0 ± 10mV)
3	(1) MPX VCO (oscillateur à fréquence réglée par variation de tension MPX) (19 kHz)		FM ANT (antenne MF) 75 ohms 22,5 kHz dév. 60 dB En non-modulation	TP. 6 Connectez par enregistreur 100 kohms	98 MHz 98,1 MHz	98 MHz 98,1 MHz	RT301	19 kHz ± 50 Hz

Note 5: Using a sweep generator, input the weak signal (with a level causing noise on the IF waveform as shown in Fig. 10) so that the waveform becomes maximum and symmetrical.

If the IF waveform does not appear or becomes as shown in Fig. 11, short the line between TP 4 and TP 5.

Note 6: Generate the S-curve and adjust so that the A and B are symmetrical and linear as shown in Fig. 12.

Remarque 5: À l'aide d'un générateur de balayage, entrez le signal faible (ayant un bruit générateur de niveau sur la forme d'onde moyenne fréquence comme indiqué en figure 10) de sorte que la forme d'onde devienne maximale et symétrique.

Si la forme d'onde moyenne fréquence n'apparaît pas ou devient semblable à la figure 11, raccourcissez la ligne entre TP 4 et TP 5.

Remarque 6: Générez la courbe en S de sorte que les A et B soient symétriques et linéaires comme indiqué en figure 12.

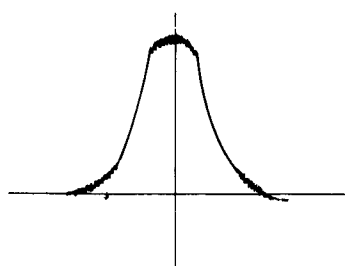

Fig. 10

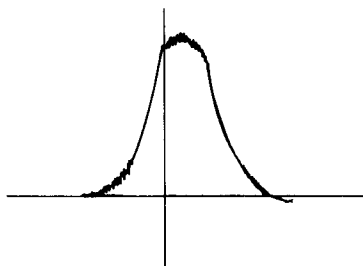

Fig. 11

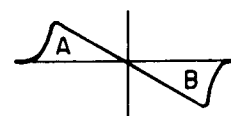

Fig. 12

AM Section

Step	Adjustment Item	Measuring Instrument and Connection			Genescope or Signal Generator Frequency	Dial Pointer Position	Adjust	Reading
		Measuring Instrument	Input Terminal	Output Terminal				
1	AM IF	Genescope (450 kHz)	TP. 7	TP. 8	450 kHz	Highest	T201	Note 7
2	MW OSC (Covering)	<ul style="list-style-type: none"> ● AM signal generator (400 Hz, 30% mod.) ● VTVM ● Oscilloscope 	—	TP. 11	[for US, CS]			
					522 kHz	522 kHz	L153	1.2V
3	LW OSC (Covering)	<ul style="list-style-type: none"> ● AM signal generator (400 Hz, 30% mod.) ● VTVM ● Oscilloscope 	—	TP. 12	[except US, CS]			
					530 kHz	530 kHz	L153	1.25V
4	MW ANT (Tracking)	<ul style="list-style-type: none"> ● AM signal generator (400 Hz, 30% mod.) ● VTVM ● Oscilloscope 	Loop antenna	SP OUT	600 kHz 603 kHz	600 kHz 603 kHz	L151	Max Note 8
5	LW ANT (Tracking)	<ul style="list-style-type: none"> ● AM signal generator (400 Hz, 30% mod.) ● VTVM ● Oscilloscope 	Loop antenna	SP OUT	164 kHz	164 kHz	L152	Max Note 8

Note 7: If the signal from the sweep generator is weak, adjust so that the waveform becomes maximum and symmetrical as shown in Fig. 13.

Raise the level of the sweep generator so that the range at point (A) becomes as flat as possible as shown in Fig. 14.

Note 8: Initially set the input level to 74 dB/m, and lower the level to minimum as required (approx. 60 dB/m) for progress of the adjustment. And adjust repeatedly so that the output is maximum at the specified frequency.

Section MA

Etape	Poste de réglage	Instrument de mesure et connexion			Fréquence du gènescope ou du générateur de signaux	Position de l'indicateur du cadran	Réglez	Lecture
		Instrument de mesure	Borne d'entrée	Borne de sortie				
1	MA IF	Gènescope (450 kHz)	TP. 7	TP. 8	450 kHz	Le plus haut possible	T201	Remarque 7
2	MW OSC (oscillateur PO) (guipage)	<ul style="list-style-type: none"> ● Générateur de signaux MA (400 Hz, 30% de mod.) ● VTVM (voltmètre électronique) ● Oscilloscope 	-	TP. 11	[Pour US, CS]			
					522 kHz	522 kHz	L153	1,2V
					[Sauf US, CS]			
					530 kHz	530 kHz	L153	1,25V
3	LW OSC (oscillateur GO) (guipage)	<ul style="list-style-type: none"> ● Générateur de signaux MA (400 Hz, 30% de mod.) ● VTVM (voltmètre électronique) ● Oscilloscope 	-	TP. 12	153 kHz	153 kHz	L154	1,2V
4	MW ANT (antenne PO) (alignement)	<ul style="list-style-type: none"> ● Générateur de signaux MA (400 Hz, 30% de mod.) ● VTVM (voltmètre électronique) ● Oscilloscope 	Antenne à boucle	SP OUT (hors circuit)	600 kHz 603 kHz	600 kHz 603 kHz	L151	Max Remarque 8
5	LW ANT (antenne GO) (alignement)	<ul style="list-style-type: none"> ● Générateur de signaux MA (400 Hz, 30% de mod.) ● VTVM (voltmètre électronique) ● Oscilloscope 	Antenne à boucle	SP OUT (hors circuit)	164 kHz	164 kHz	L152	Max Remarque 8

Remarque 7 : Si le signal provenant du générateur de balayage est faible, réglez de sorte que la forme d'onde devienne maximale et symétrique comme indiqué en figure 13.
Augmentez le niveau du générateur de balayage de sorte que le parcours au point A soit aussi plat que possible comme indiqué en figure 14.

Remarque 8 : Placez tout d'abord le niveau d'entrée à 74 dB/m, et abaissez le niveau au minimum comme il vous l'est demandé (environ 60 dB/m) pour continuer le réglage. Réglez à plusieurs reprises de façon à ce que la sortie soit maximale à la fréquence spécifiée.

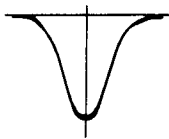

Fig. 13

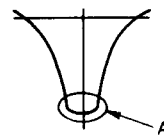
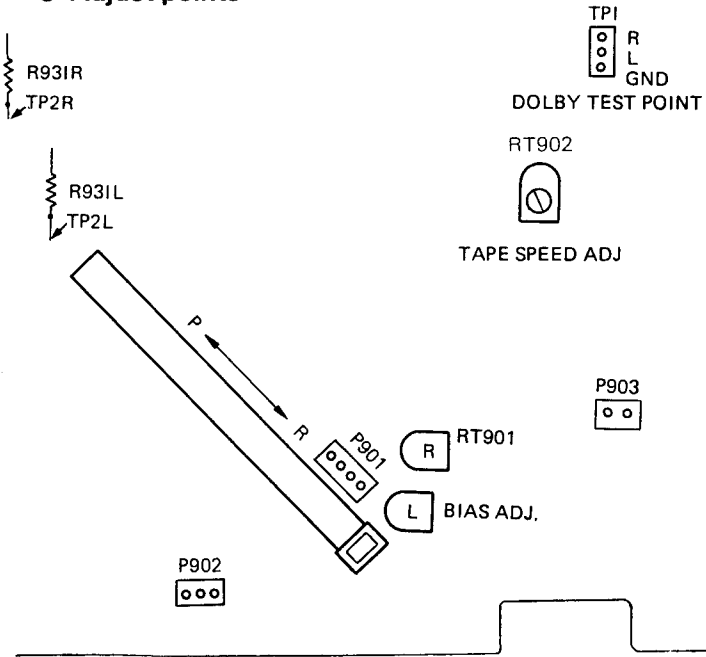

Fig. 14

2. TAPE TECK SECTION

● Adjust points



Symbol No.	Switches and Controls	Position
S903	DOLBY NR	OFF
S902	TAPE SELECTOR SW	NOR
RT901L, R	REC VOL	MAX
S905	Rif SW	A

Perform the following adjustments in the sequence stated after cleaning the head, pressure roller, and capstan with a head cleaning stick moistened in alcohol.

Adjustment:

Record 400 Hz and 10 kHz signals at the level of -25 dB. Set the record mode, and if there is a difference of more than -25 dB \pm 1.5 dB in output, adjust RT901L, R.

Measure the record/playback frequency characteristic of the UD tape at the level of -25 dB. Then make sure that the measured value is within the range of the specification.

(1) Head azimuth adjustment

Setting: Playback mode.

Connection:

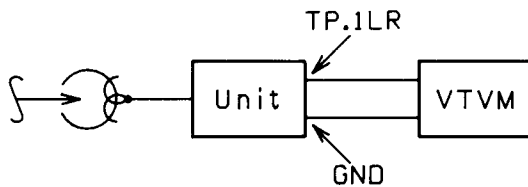

Adjustment:

Playback test tape (MTT-114, 10 kHz) and adjust the azimuth adjustment screw for maximum output however, if the peak level differs between the left and right channels, set it to the left-channel peak level. At this time, the difference between both channel peak levels should be within 3 dB.

After adjustment, lock the screw.

(2) Frequency characteristic adjustment (Bias adj.)

Setting: Recording/Playback mode

Connection:

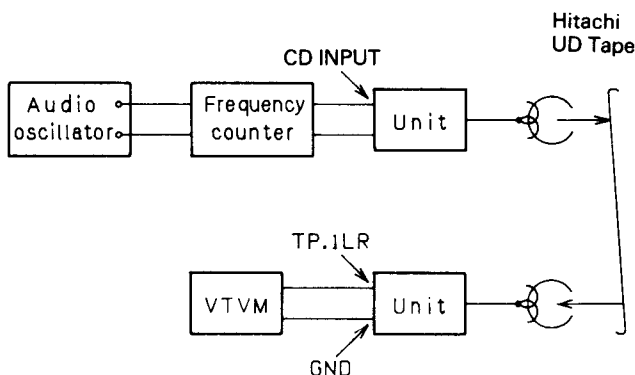

(3) Dolby check

With the recording mode, apply 5 kHz input to the CD INPUT and set the voltage between the Dolby test point TP. 1LR and the ground to 300 mV -30 dB.

Check that the voltage between the TP. 2L, R and the ground is -21.8 dB \pm 2 dB when the Dolby switch is turned ON.

(4) Tape speed adjustment

Item	Adjustment point	Procedure
Tape speed adjustment	RT902	Playback MTT-111N in TAPE 2 and adjust. (Adjust NOR) NOR \rightarrow 3000 \pm 30 Hz

2. SECTION MAGNETOCASSETTE

• Points de réglage

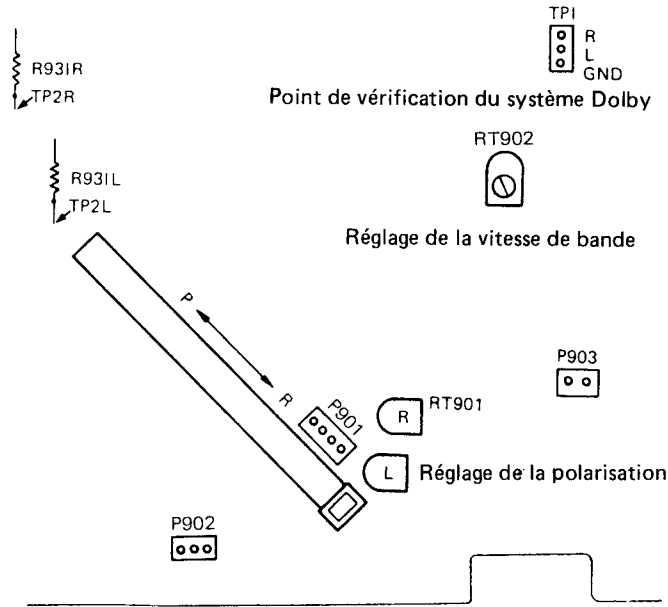

(1) Réglage de l'azimut de tête

Mise au point: mode de reproduction
Connexion:

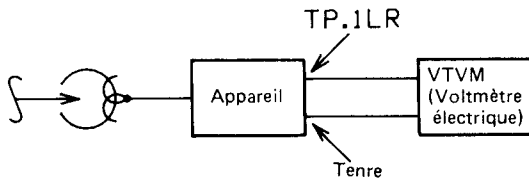

Réglage:

Reproduisez la bande d'essai (MTT-114, 10 kHz) et réglez la vis de réglage azimutal pour obtenir une sortie maximale, néanmoins, si le niveau de crête diffère entre le canal gauche et le canal droit, réglez-le au niveau de crête du canal gauche. A ce moment, la différence entre les deux niveaux de crête des canaux devrait être d'un ordre de 3 dB. Après réglage, vissez la vis.

(2) Réglage caractéristique des fréquences (réglage de la polarisation)

Mise au point: mode d'enregistrement/reproduction

Connexion:

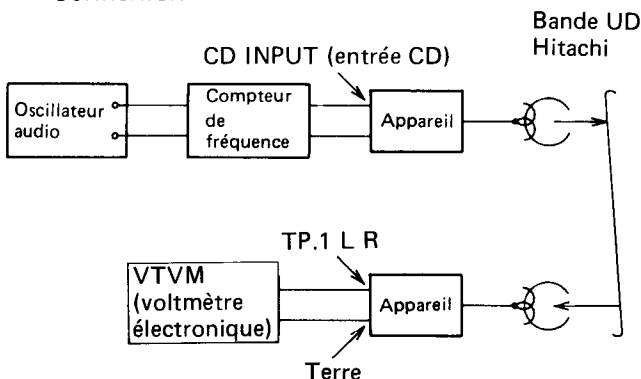

Número de symbole	Commutateurs et commandes	Position
S903	DOLBY NR	OFF (hors circuit)
S902	TAPE SELECTOR SW (sélecteur de bande)	NOR
RT901 L, R	REC VOL (volume de l'enregistrement)	MAX
S905	Rif SW (Commutateur Rif)	A

Effectuez les réglages suivants dans l'ordre spécifié après nettoyage de la tête, du galet-presseur et du cabestan à l'aide d'un coton-tige imbibé d'alcool.

Réglage:

Enregistrez des signaux de 400 Hz et 10 kHz à un niveau de -25 dB. Placez en mode d'enregistrement, et si vous obtenez une différence de plus de -25 dB $\pm 1,5$ dB à la sortie, réglez RT901 L, R.

Mesurez la fréquence d'enregistrement/reproduction caractéristique de la bande UD au niveau de -25 dB. Puis vérifiez que la valeur mesurée est comprise dans la gamme de spécification.

(3) Vérification du système Dolby

En mode d'enregistrement, appliquez une entrée de 5 kHz à l'entrée CD (CD INPUT) et réglez la tension entre le point de vérification Dolby TP.1 L, R et la terre à 300 mV -30 dB. Vérifiez que la tension entre le point TP.2L, R et la terre est $-21,8$ dB ± 2 dB lorsque le commutateur Dolby est en circuit (ON).

(4) Réglage de la vitesse de bande

Point	Réglez	Mise au point
Réglage de la vitesse bande	RT902	Placez MTT-111N sur reproduction cassette 2 (TAPE 2) pour effectuer le réglage (réglez en position NOR). NOR (vitesse normale) $\rightarrow 300 \pm 30$ Hz

3. TURNTABLE SECTION (HT-MD28)

Speed adjustment (Fig. 9)

If the specified speed cannot be obtained after replacing the motor, use the stroboscopic disk. (Adjustment is possible without removing the bottom plate.)

Note: Before adjustment, perform more than 10 minutes warmup with the turntable at 33-1/3 rpm. Carry out this adjustment in the order of (1) and (2).

- (1) Set the speed to 33-1/3 rpm, and adjust (A) so as to obtain the rated speed (33-1/3 rpm).
- (2) Set the speed of 45 rpm, and adjust (B) so as to obtain the rated speed (45 rpm).

3. SECTION PLATINE (HT-MD28)

Réglage de la vitesse (Fig. 9)

Si la vitesse prévue ne peut être obtenue après avoir remplacé le moteur, utiliser le disque stroboscopique. (Réglage est possible sans enlever la plaque de fond.)

Remarque: Avant le réglage, effectuer un préchauffage au moins 10 minutes la table tournante étant à 33-1/3 tr/mn. Procéder à ce réglage dans l'ordre de (1) et (2).

- (1) Mettre la vitesse sur 33-1/3 tr/mn et régler (A) de manière à obtenir la vitesse nominale (33-1/3 tr/mn).
- (2) Mettre la vitesse sur 45 tr/mn et régler (B) de manière à obtenir la vitesse nominale (45 tr/mn).

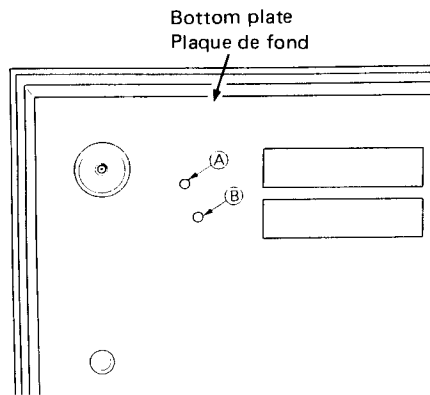

INSPECTION OF MECHANISM · INSPECTION DU MECANISME

Item	Checking item	Reference value	Remarks
1	Pressure of pressure roller	300 – 500g	Note
2	Take-up torque	30 – 60 g·cm	
3	Fast forward/Rewind torque	50g·cm or more	
4	Auto-Stop sensor operation force	40 – 75 g	
5	Brake torque	15 g·cm or more	Measured in stop mode
6	Back tension torque	Take-up	1 – 6 g·cm
		Supply	1 – 4 g·cm
7	Flywheel thrust gap	0.05 – 0.5 mm	
8	Button operation force	Play button	1.1 kg or less
		FF button	0.8 kg or less
		Rewind button	1.1 kg or less
		Eject button	0.6 kg or less
		Record button	1.0 kg or less
		Pause button	1.0 kg or less

Point	Poste de vérification		Valeur de référence	Remarques
1	Pression du galet-presseur		300 – 500 g	Remarque
2	Couple d'enroulage		30 – 60 g·cm	
3	Couple d'avancée rapide/rembobinage rapide		50 g·cm ou plus	
4	Effort à l'utilisation du détecteur pour arrêt automatique		40 – 75 g	
5	Couple de freinage		15 g·cm ou plus	Mesuré en mode d'arrêt
6	Couple de tension de recul	Enroulage	1 – 6 g·cm	
		Alimentation	1 – 4 g·cm	
7	Intervalle de poussée du volant		0,05 – 0,5 mm	
8	Effort à l'utilisation des touches	Touche de reproduction	1,1 kg ou moins	
		Touche d'avancée rapide	0,8 kg ou moins	
		Touche de rembobinage	1,1 kg ou moins	
		Touche d'éjection	0,6 kg ou moins	
		Touche d'enregistrement	1,0 kg ou moins	
		Touche de pause	1,0 kg ou moins	

Note:

Set this unit in the playback mode and press the pressure roller in the direction of the arrow using a fan type tension gauge, and measure the pressure when the pressure roller is released from the capstan.

Remarque:

Placez cet appareil en mode de reproduction, appuyez sur le galet-presseur dans le sens de la flèche à l'aide d'un calibre de tension type éventail, et mesurez la pression lorsque le galet-presseur est libéré du cabestan.

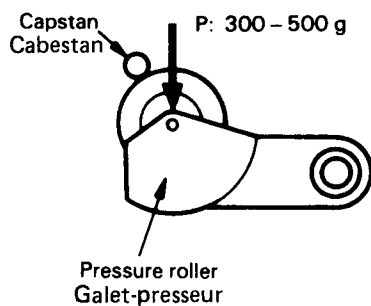

LUBRICATION

Lubricate one or two drops of oil to rotating point or lubricate grease to sliding point.

Lubricate the respective parts listed once every 1000 hours or once a year under normal conditions of use.

Avoid oiling them excessively, or rotation may become irregular because of oil splashes.

Lubrication point		Oil or Grease
Rotary section	Metal and metal	Pan motor oil (10W-40)
	Mold and metal	Sonic slider oil (# 1600)
Sliding section	Metal and metal	Hitasol (MO-138)
	Mold and mold Mold and metal	White grease (FL-LUBE-A)
Spring resonance prevention		Floil (GB-TS-1)

LUBRIFICATION

Lubrifiez d'une ou deux gouttes d'huile au point de rotation ou lubrifiez de graisse le point de glissement.

Lubrifiez les pièces respectives énumérées toutes les 1000 heures ou une fois par an lors d'un usage normal de l'appareil.

Évitez une lubrification excessive, car le mouvement rotatif serait perturbé par les éclaboussures d'huile.

Point de lubrification		Huile ou graisse
Section rotative	Métal et métal	Huile de moteur PAN (10W-40)
	Métal et moulé	Huile de curseur sonic (# 1600)
Section glissante	Métal et métal	Hitasol (MO-138)
	Moulé et moulé Moulé et métal	Graisse blanche (FL-LUBE-A)
Prévention de résonance du ressort		Floil (GB-TS-1)

MAINTENANCE

■ Clean cabinet and panels when dirty

Clean off dirt on the surfaces with a dry cloth. Never use thinners, benzene or alcohol since these will damage the surface finish.

ENTRETIEN

■ Nettoyage du coffret et de panneaux lorsqu'ils sont sales

Enlever la poussière des surfaces de l'appareil avec un chiffon sec. Ne jamais utiliser de solvants, de benzine ou d'alcool car ils abîmeraient le fini des surfaces.

Utilisez les condensateurs électrolytiques derniers est supérieur à 10 mmφ.
* : Axial lead cylindrical ceramic capacitor *

Use explosion-proof capacitors with explosion-proof valve when the diameter of them is more than 10 mmφ.

TUNER SECTION (for MD18)

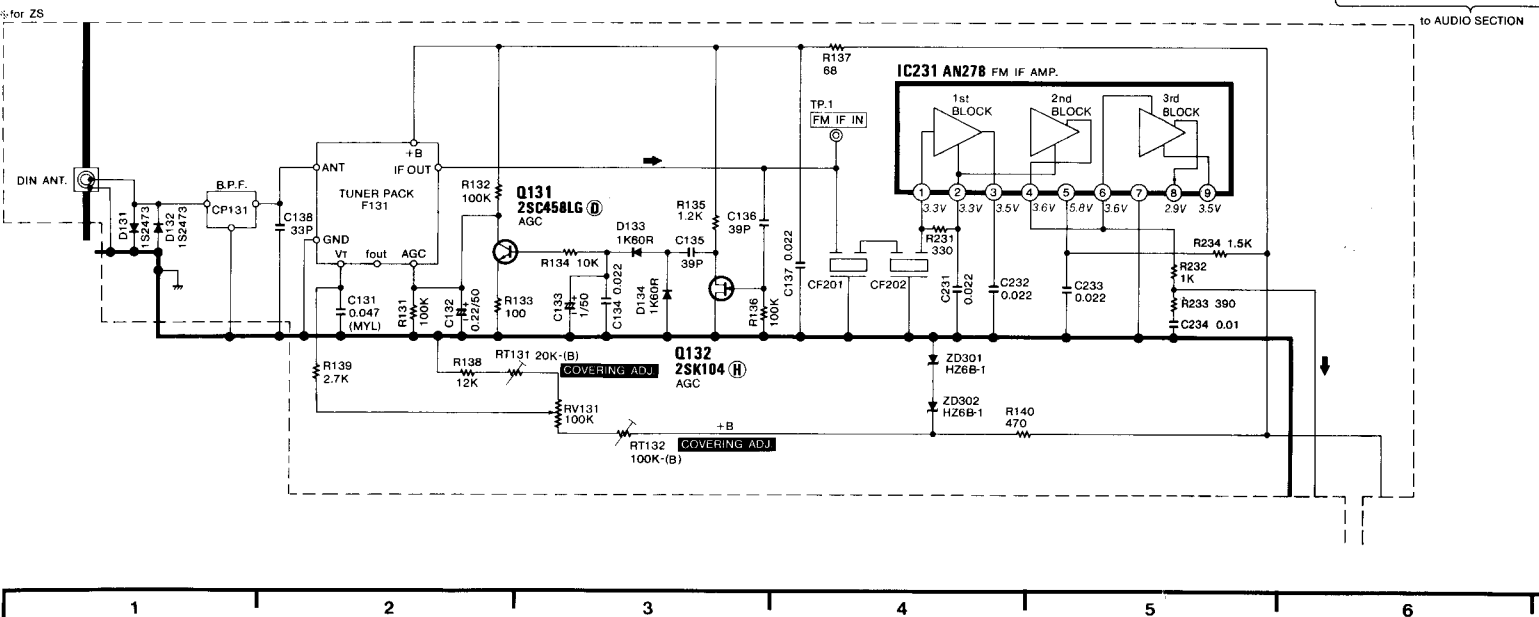
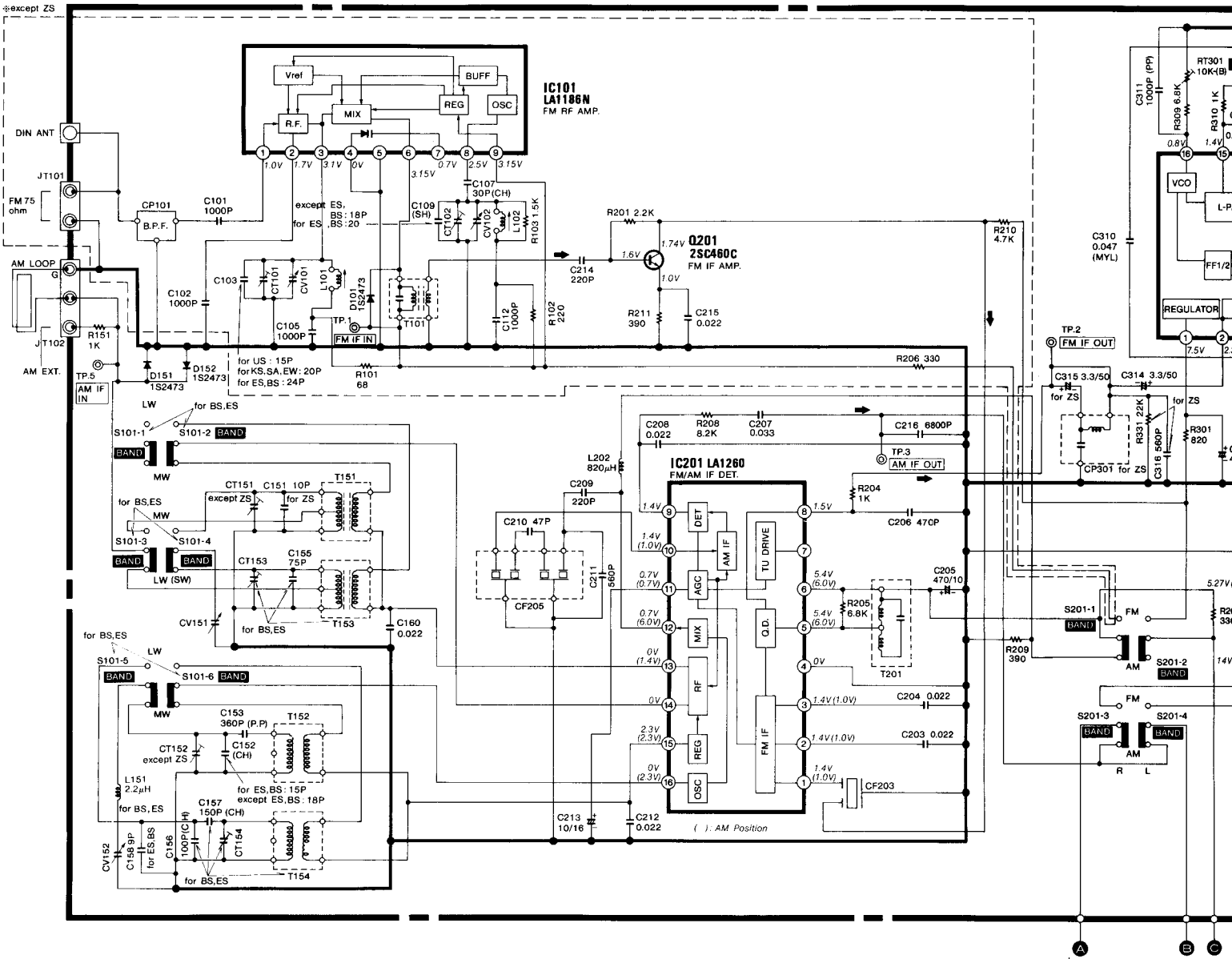

of them is more than 10 mmφ.

ATTENTION

Utilisez les condensateurs électrolytiques à soupape hermétique lorsque le diamètre de ceux-ci est supérieur à 10 mmφ.

* : Axial lead cylindrical ceramic capacitor * : Condensateur céramique cylindrique à conducteur axial

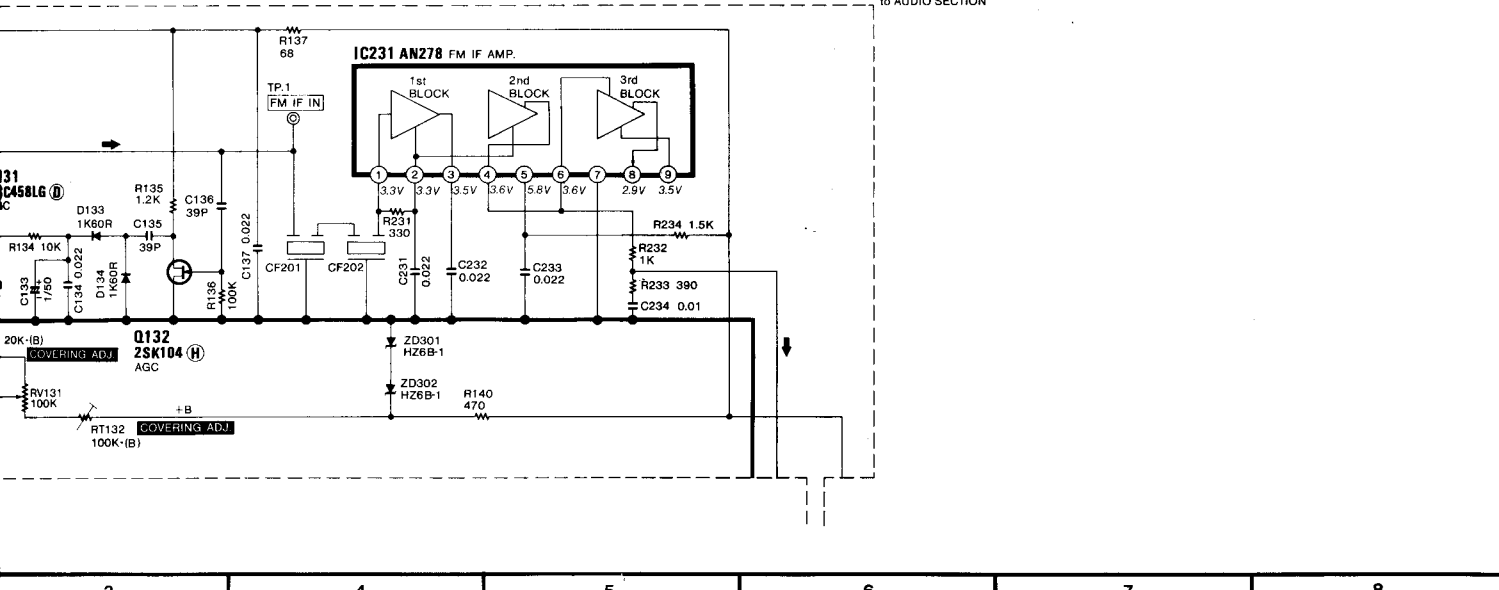
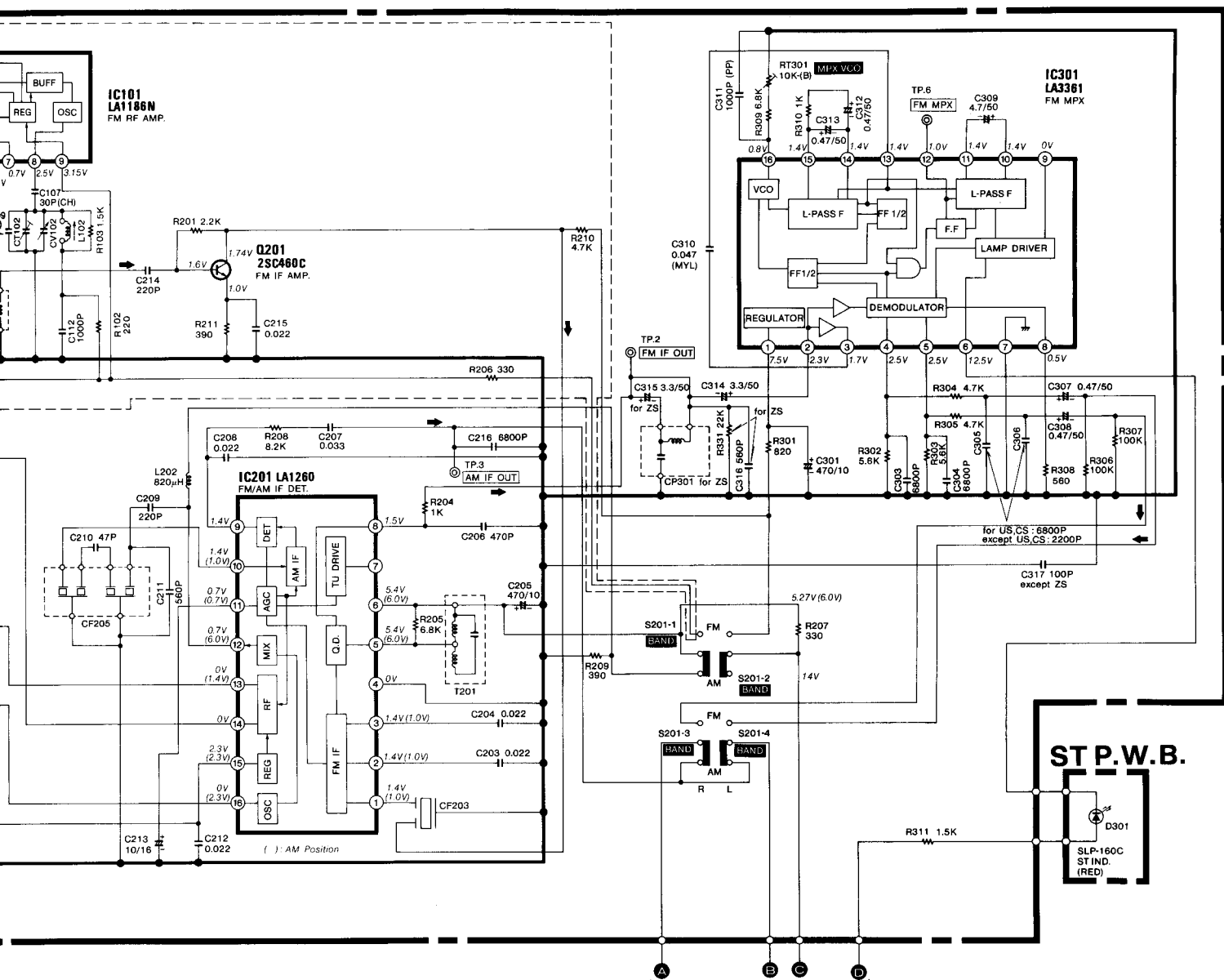

A
B
C
D
E
F
G

3 4 5 6 7 8

AUDIO SECTION (for MD18)

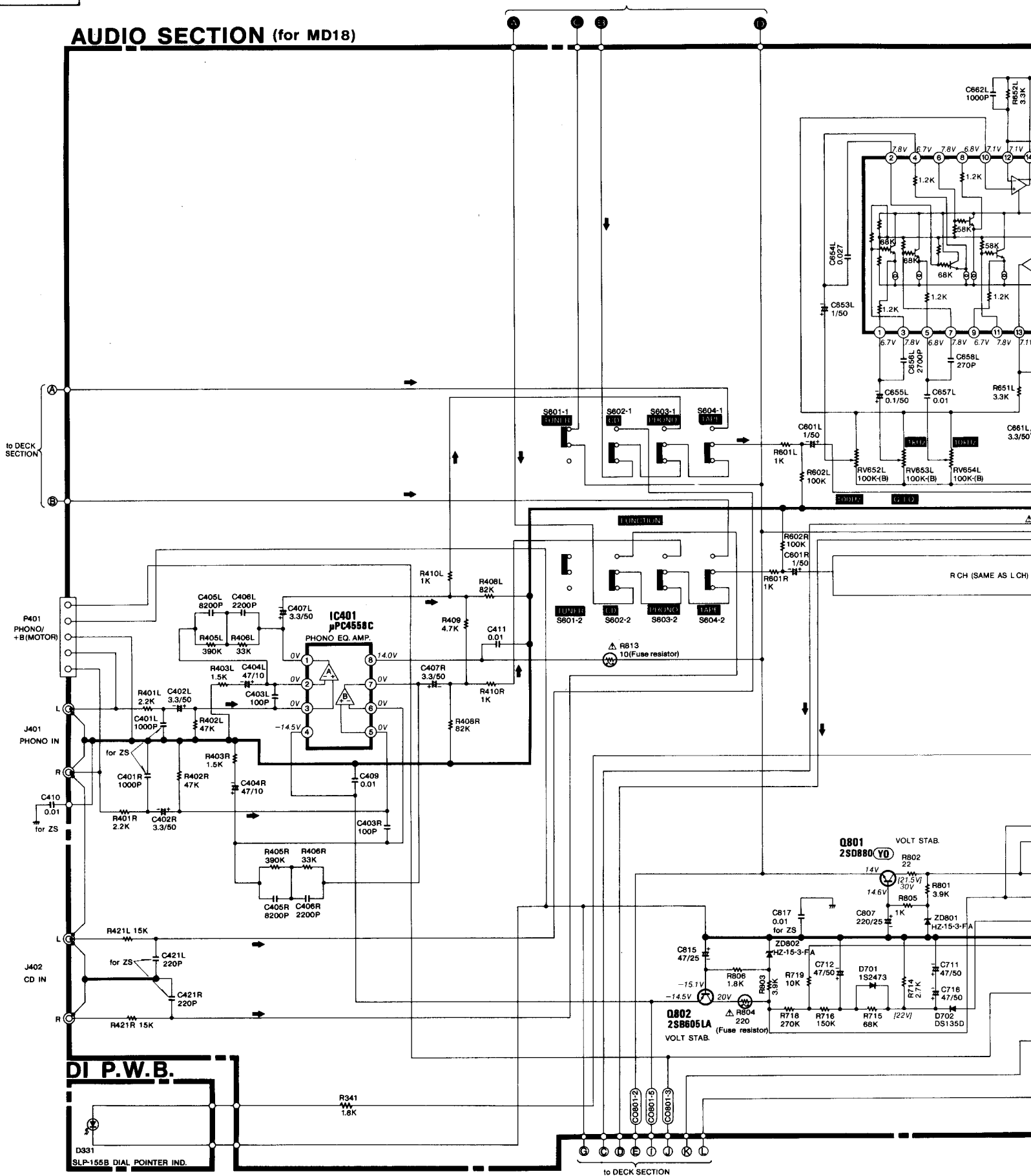

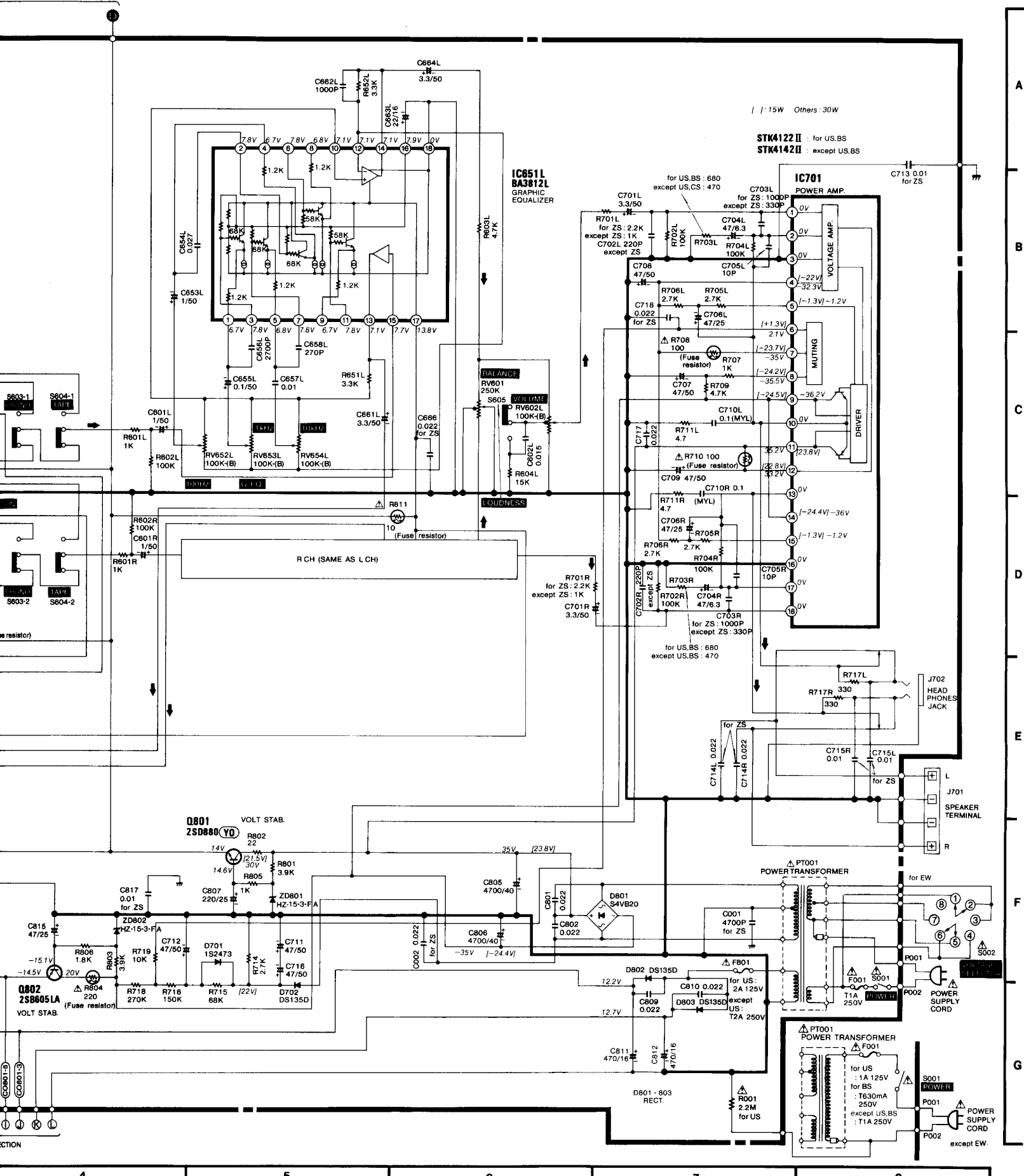

[] : 15W Others : 30W

STK4122 II : for US, BS
STK4142 II : except US, BS

IC651L
BA3812L
GRAPHIC
EQUALIZER

IC701
POWER AMP.

Q801
ZSD880
VOLT STAB.

Q802
ZSB605LA
VOLT STAB.
(Fuse resistor)

PT001
POWER TRANSFORMER

PT001
POWER TRANSFORMER

D801 - 803
RECT.

S001
POWER
POWER SUPPLY CORD

S002
POWER SUPPLY CORD
except EW.

A
B
C
D
E
F
G

4 5 6 7 8

TUNER SECTION (for MD28)

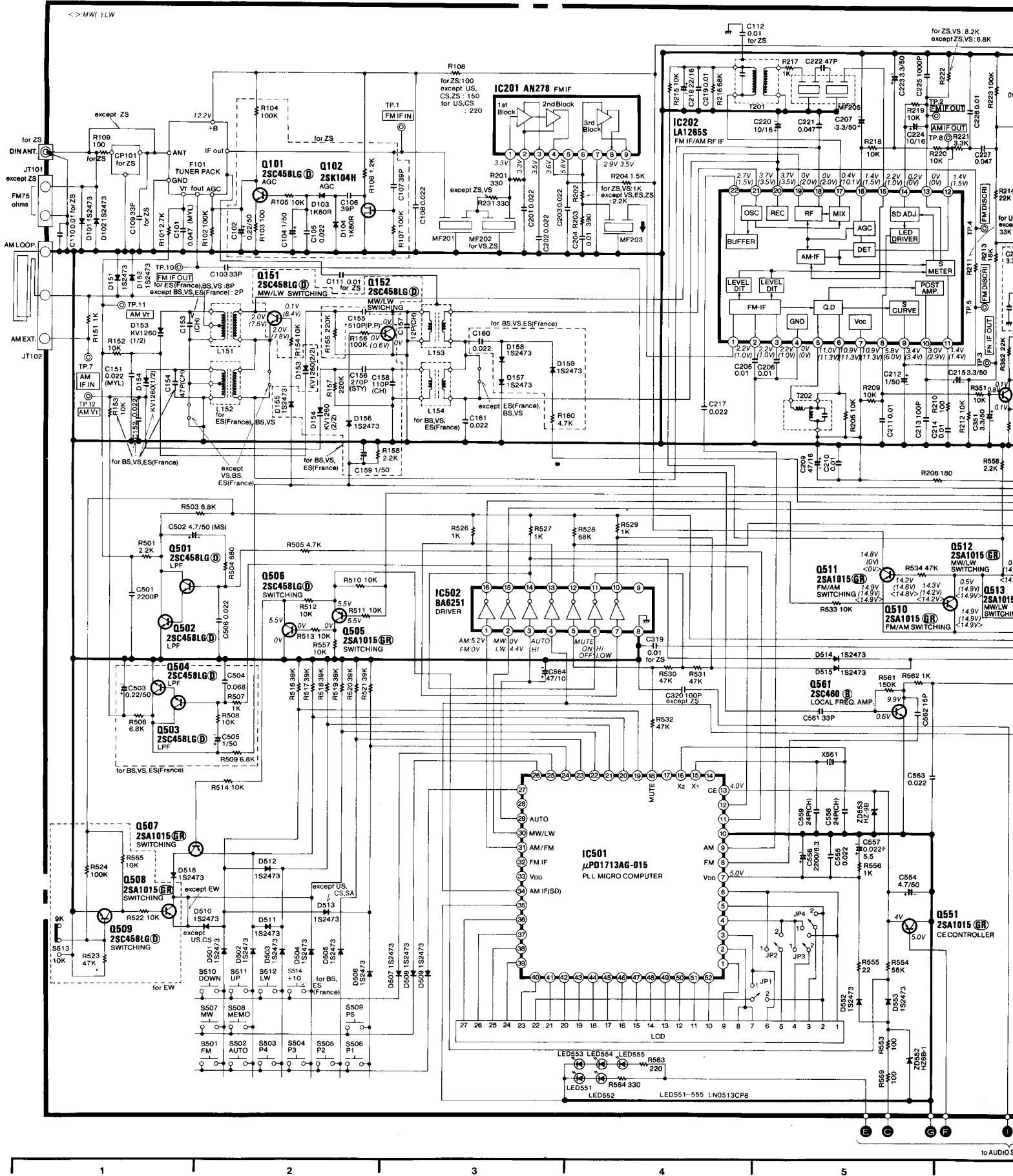

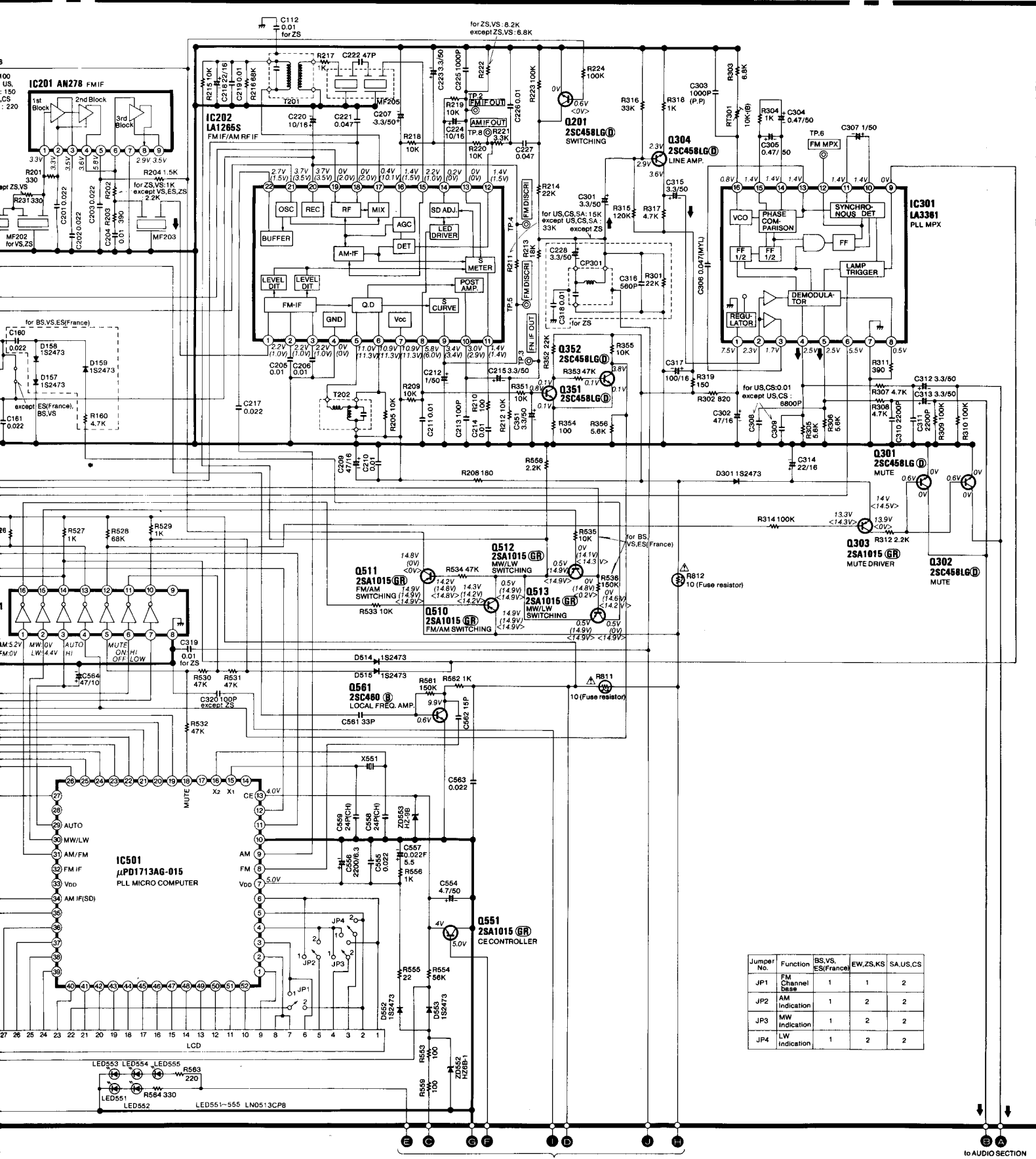

Jumper No.	Function	BS.VS. ES(France)	EW.ZS.KS	SA.US.CS
JP1	FM Channel Base	1	1	2
JP2	AM Indication	1	2	2
JP3	MW Indication	1	2	2
JP4	LW Indication	1	2	2

to AUDIO SECTION

to AUDIO SECTION

AUDIO SECTION (for MD28)

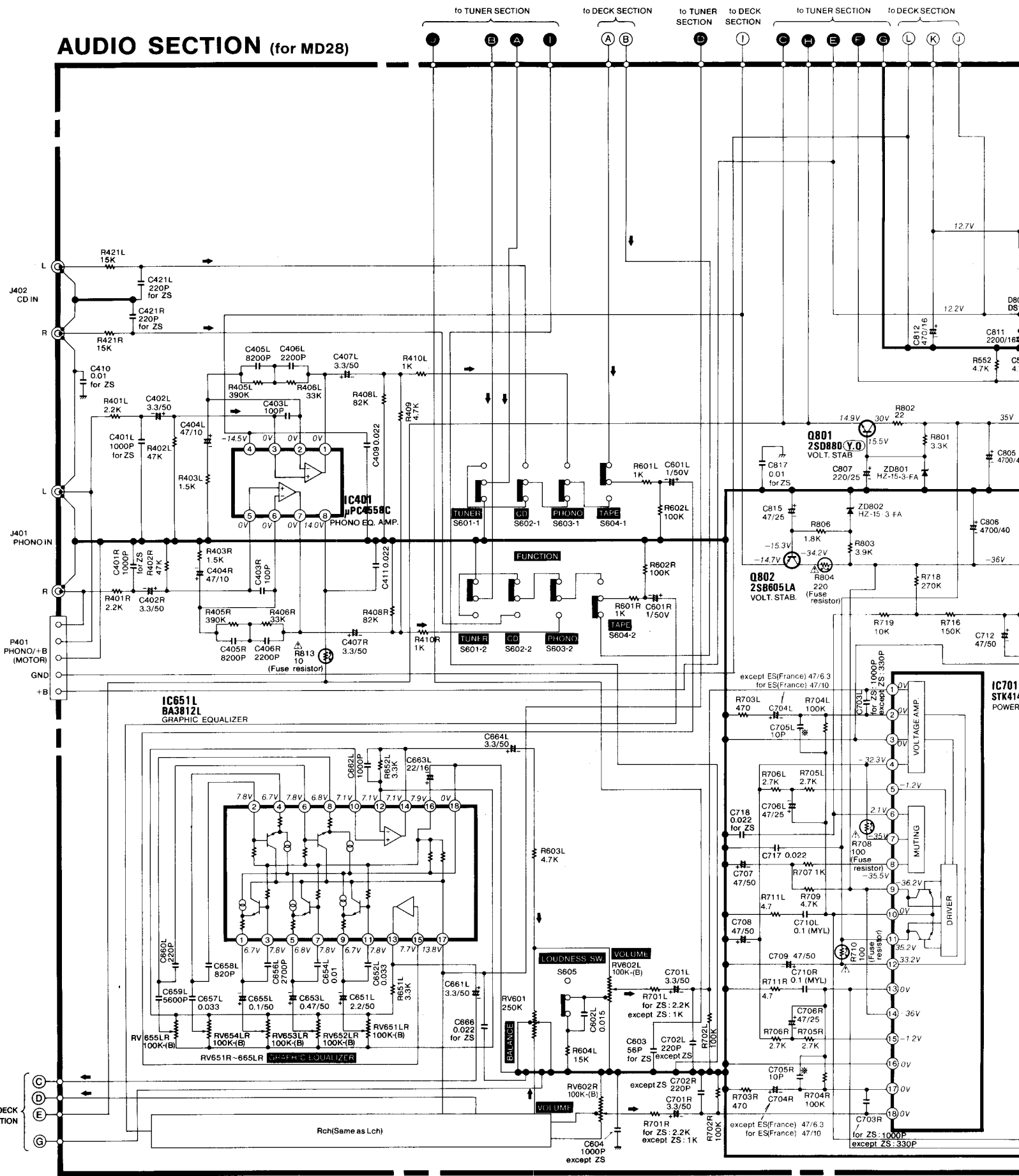

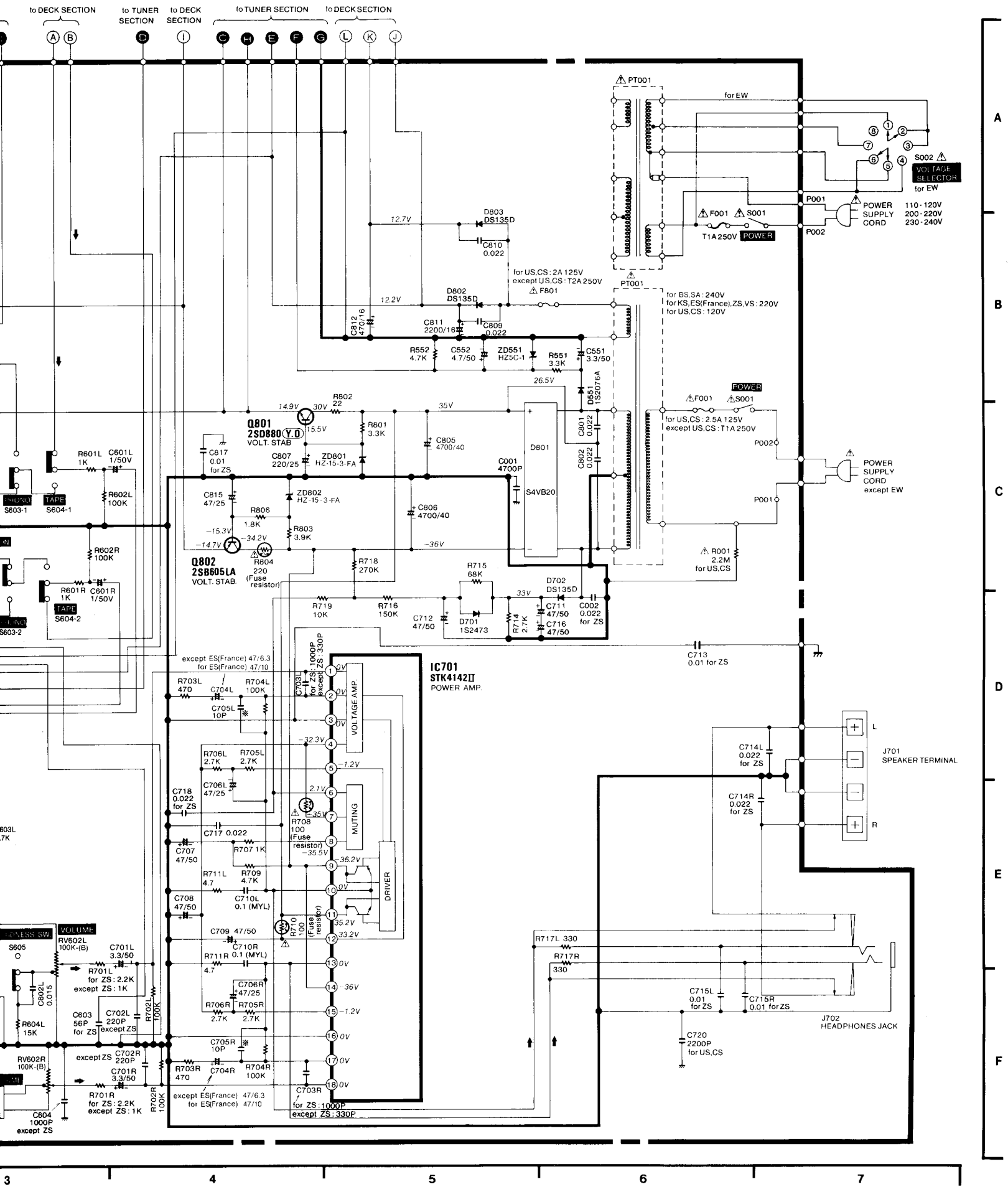

A
B
C
D
E
F

3

4

5

6

7

DECK SECTION (for MD18/28)

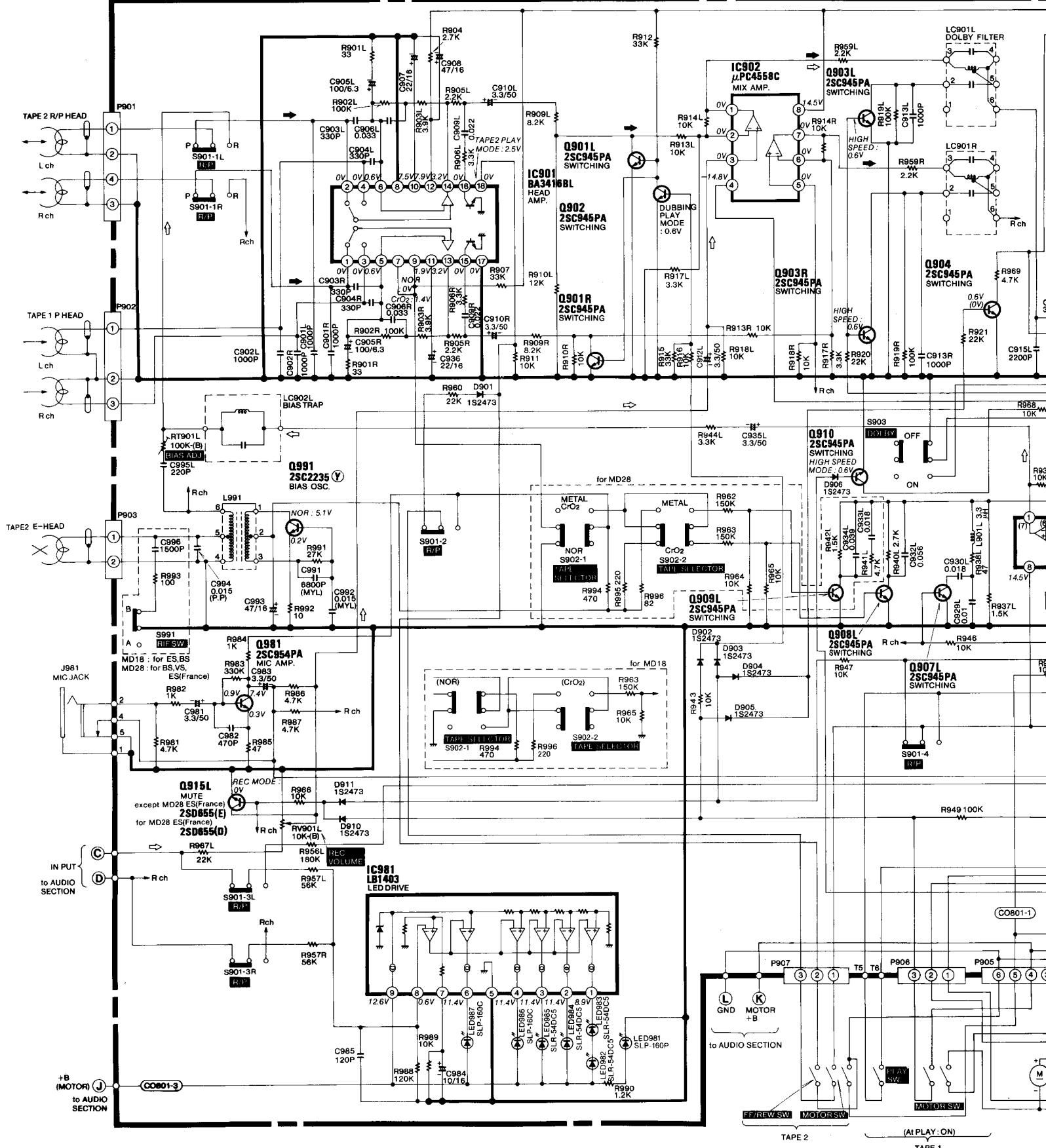

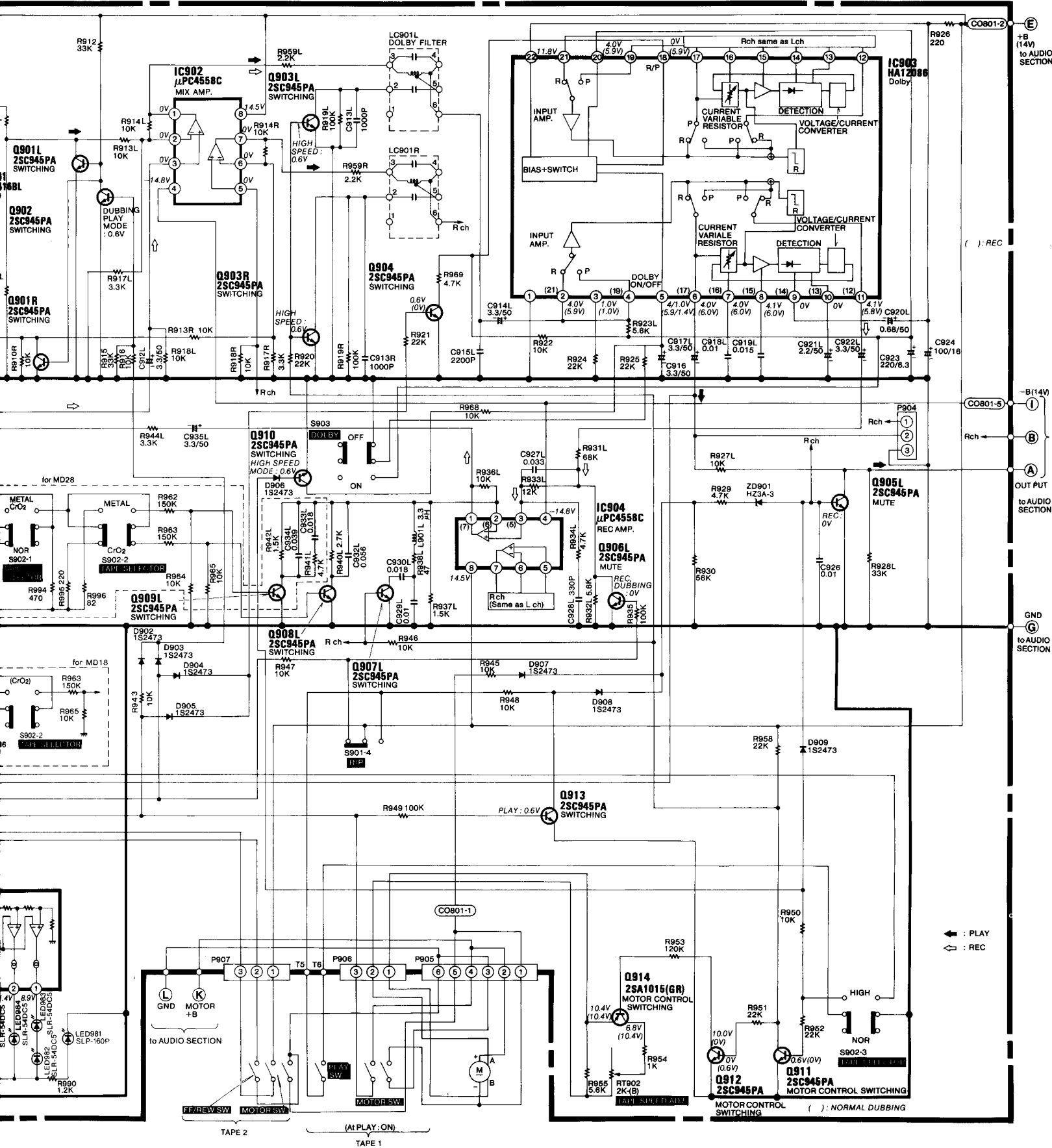

3

4

5

PRINTED WIRING BOARD • PLAN DE BASE

TD P.W.B. (for MD18) [for ZS]

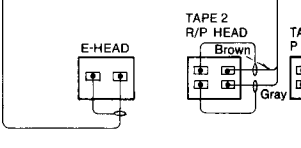
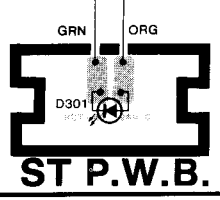
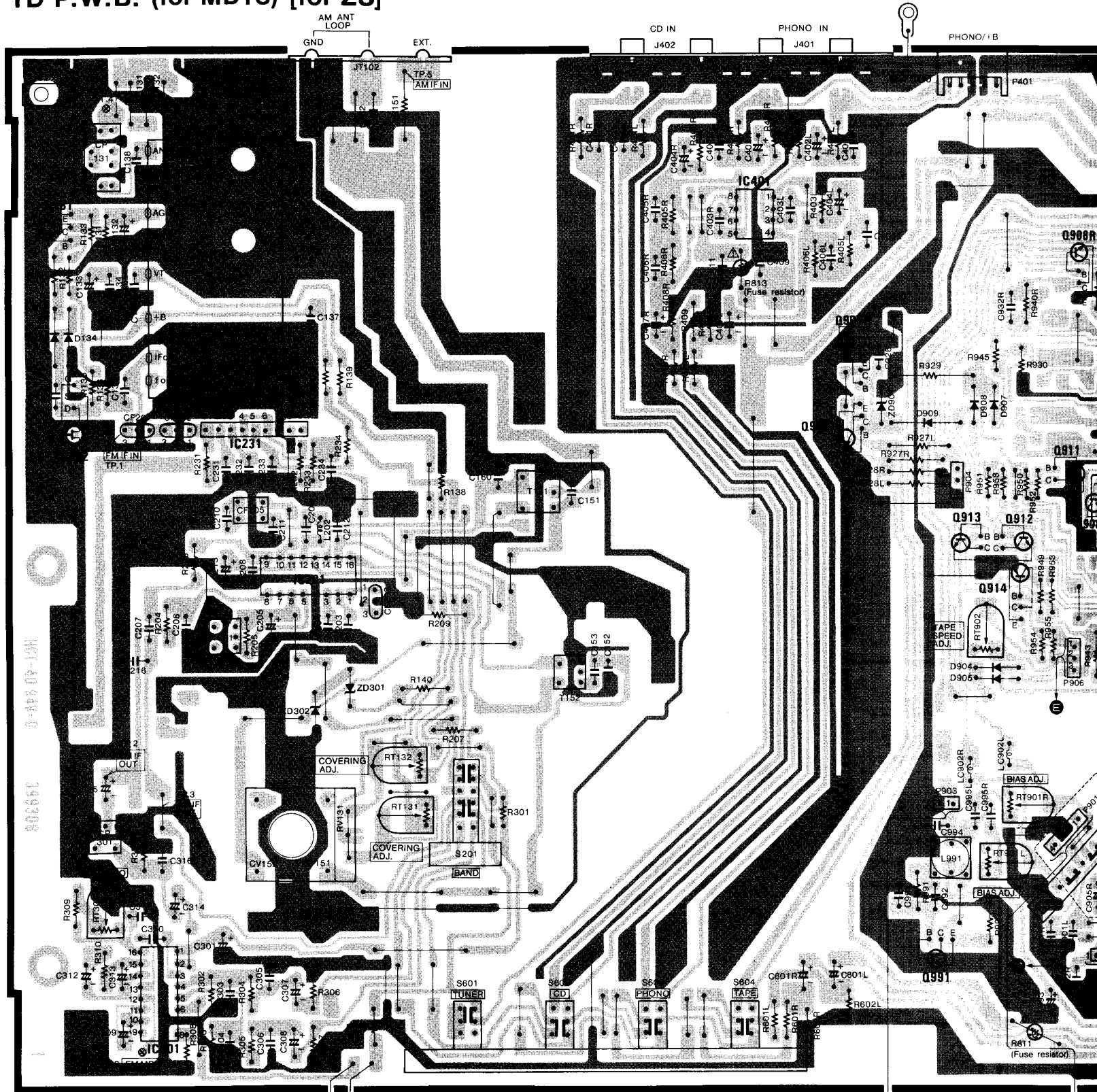

ST P.W.B.

BASE

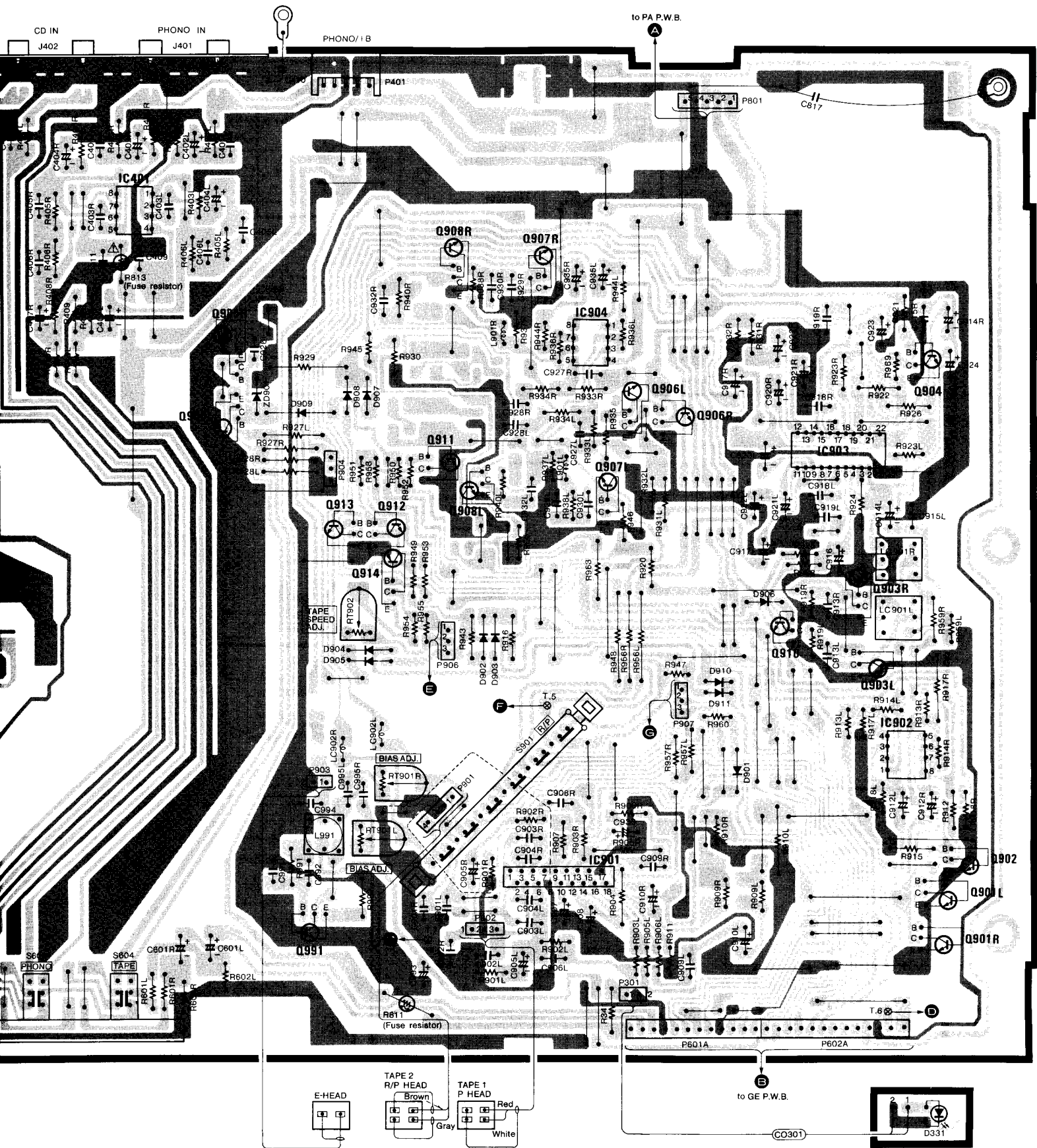

DI P.W.B.

TD P.W.B. (for MD18) [except ZS]

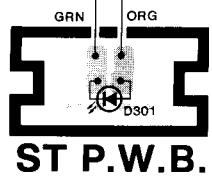
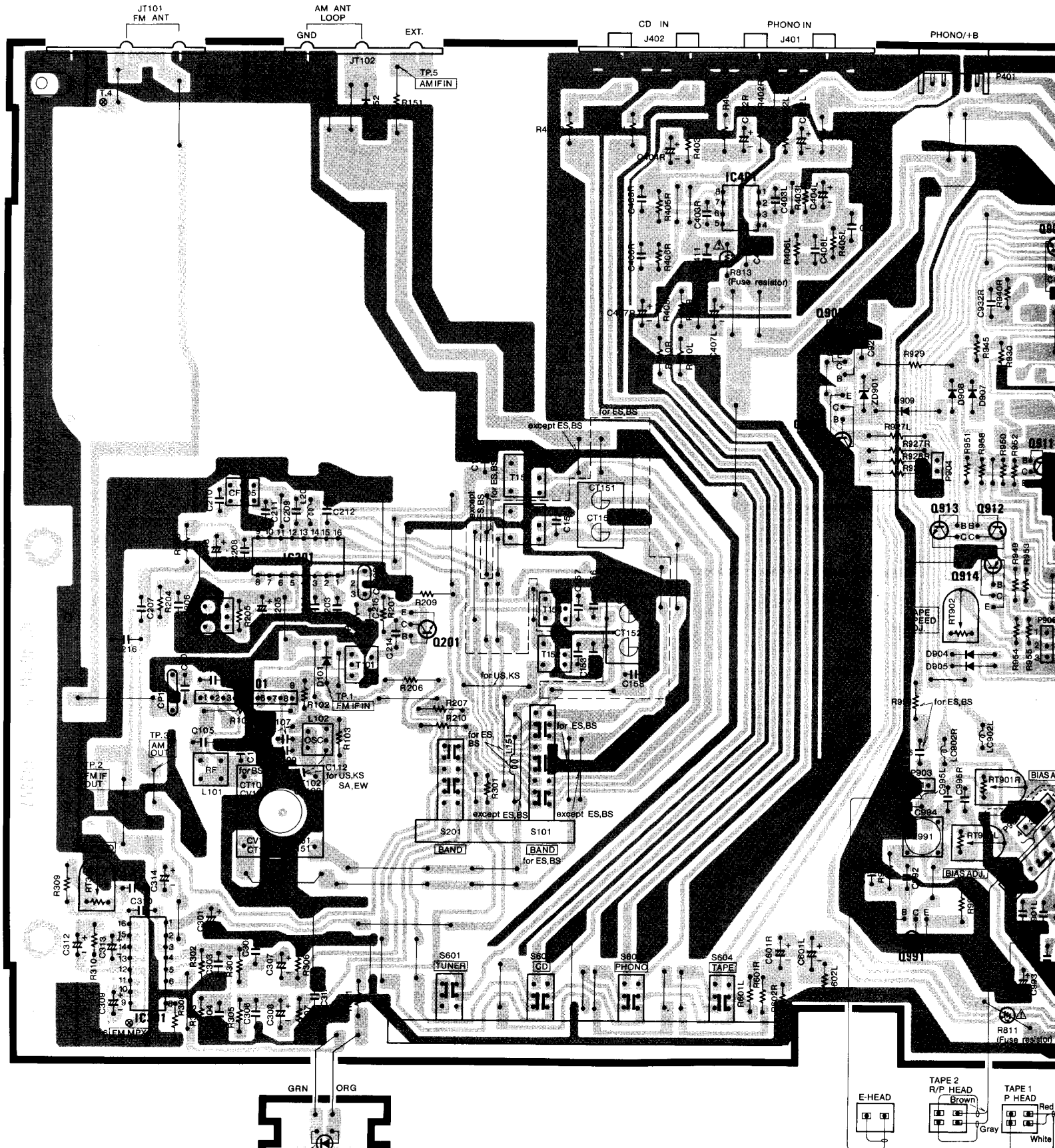

ST P.W.B.

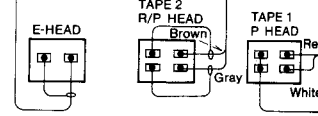

1

2

3

4

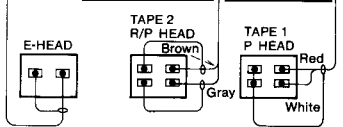
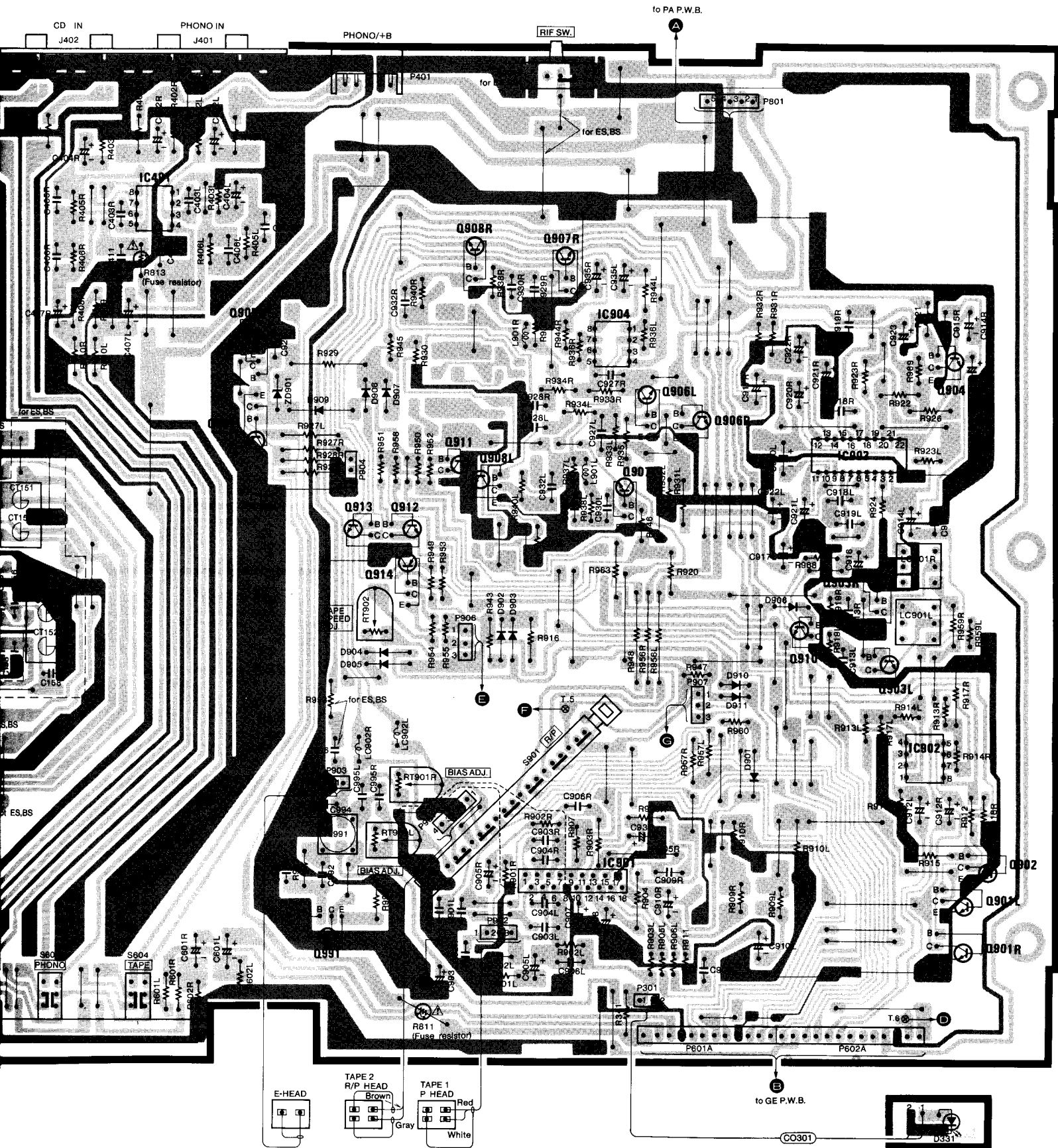

GE P.W.B. (for MD18) (for EW)

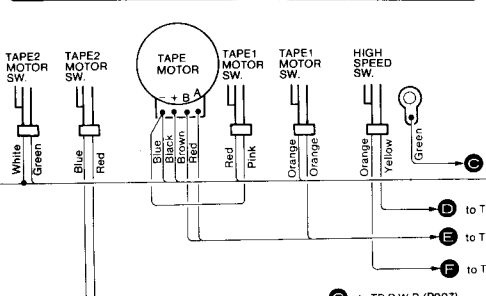
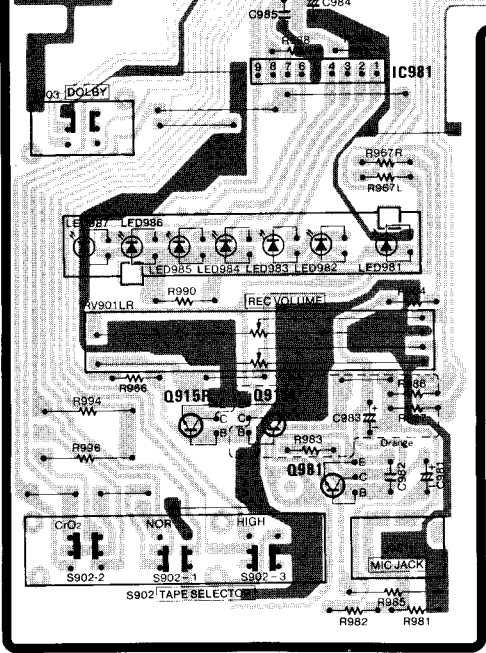
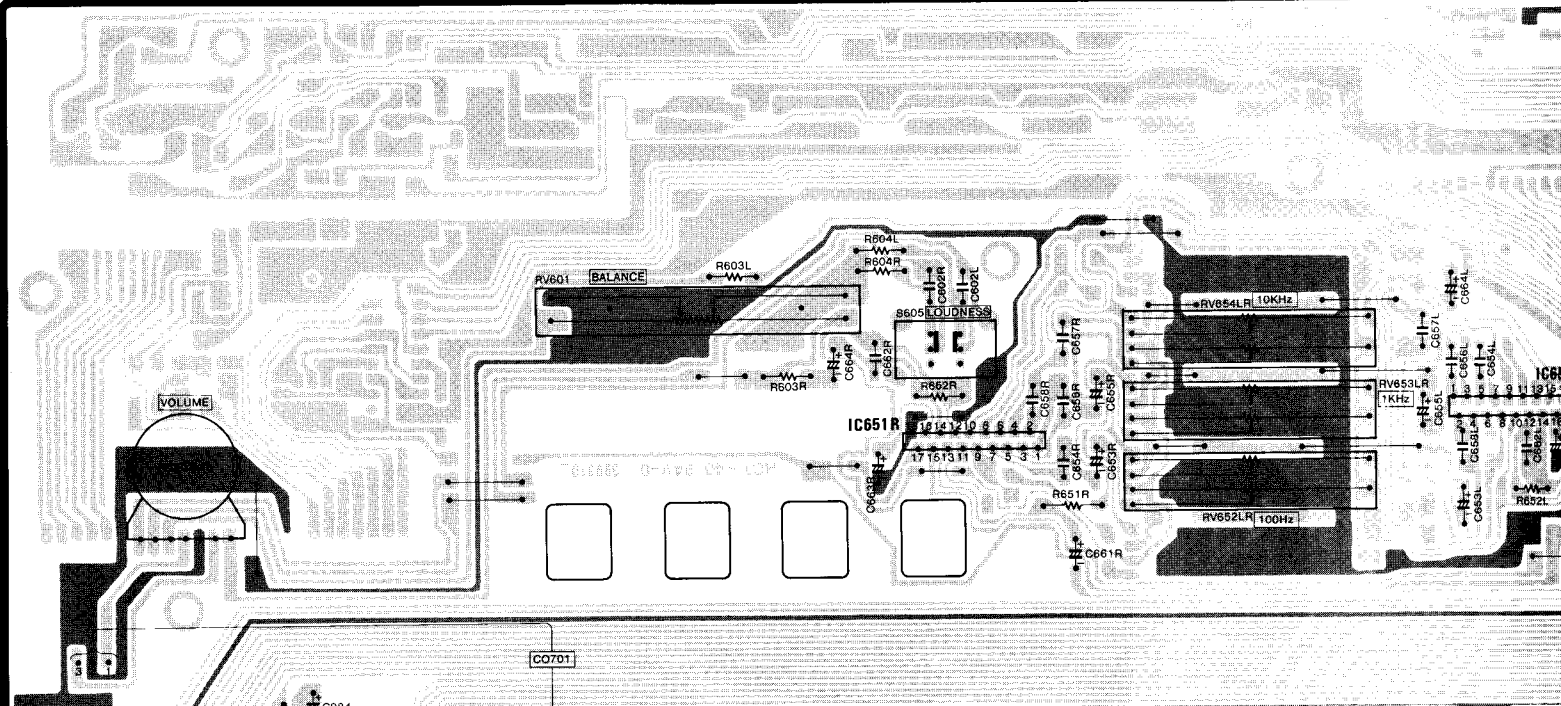

PA P.W.B. (for MD18)(for EW)

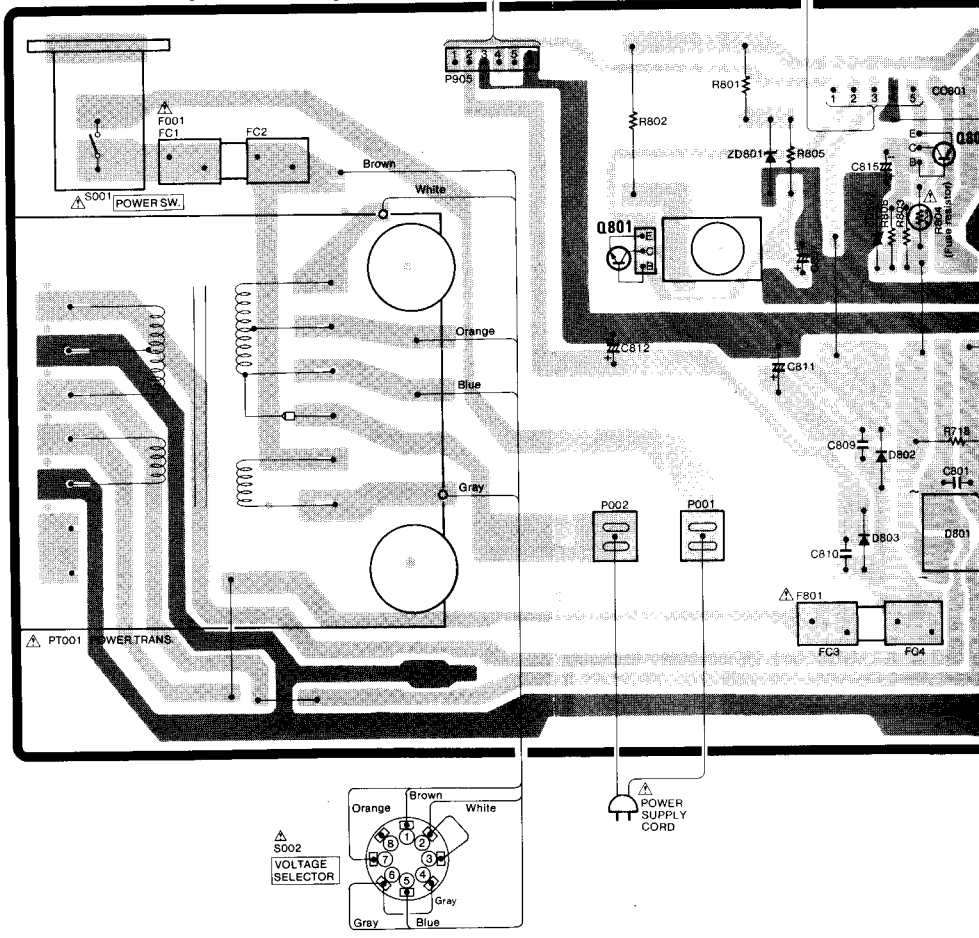

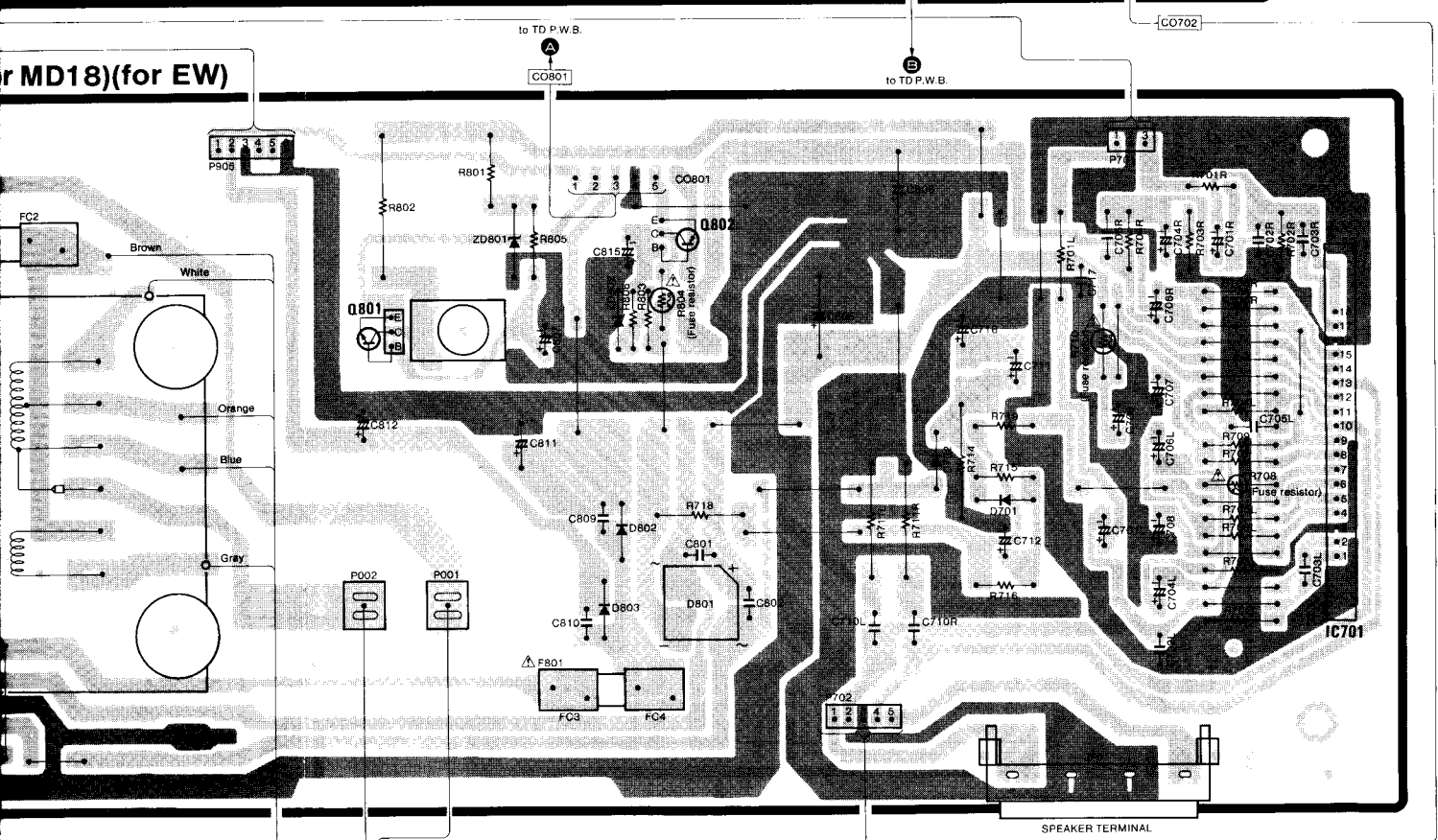
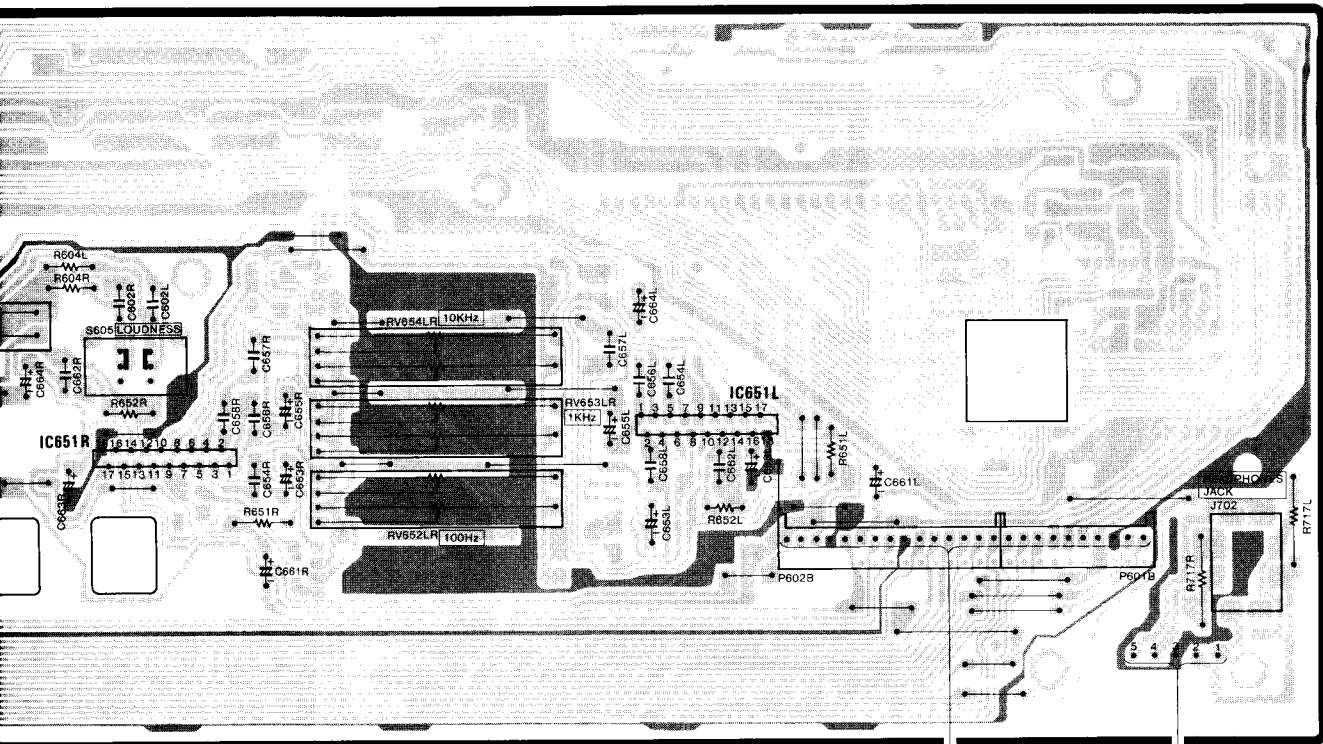

MD18)(for EW)

▲ S002
VOLTAGE
SELECTOR

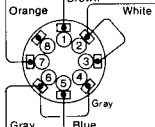

A
B
C
D
E
F

4 5 6 7 8 9

GE P.W.B. (for MD18)[except EW]

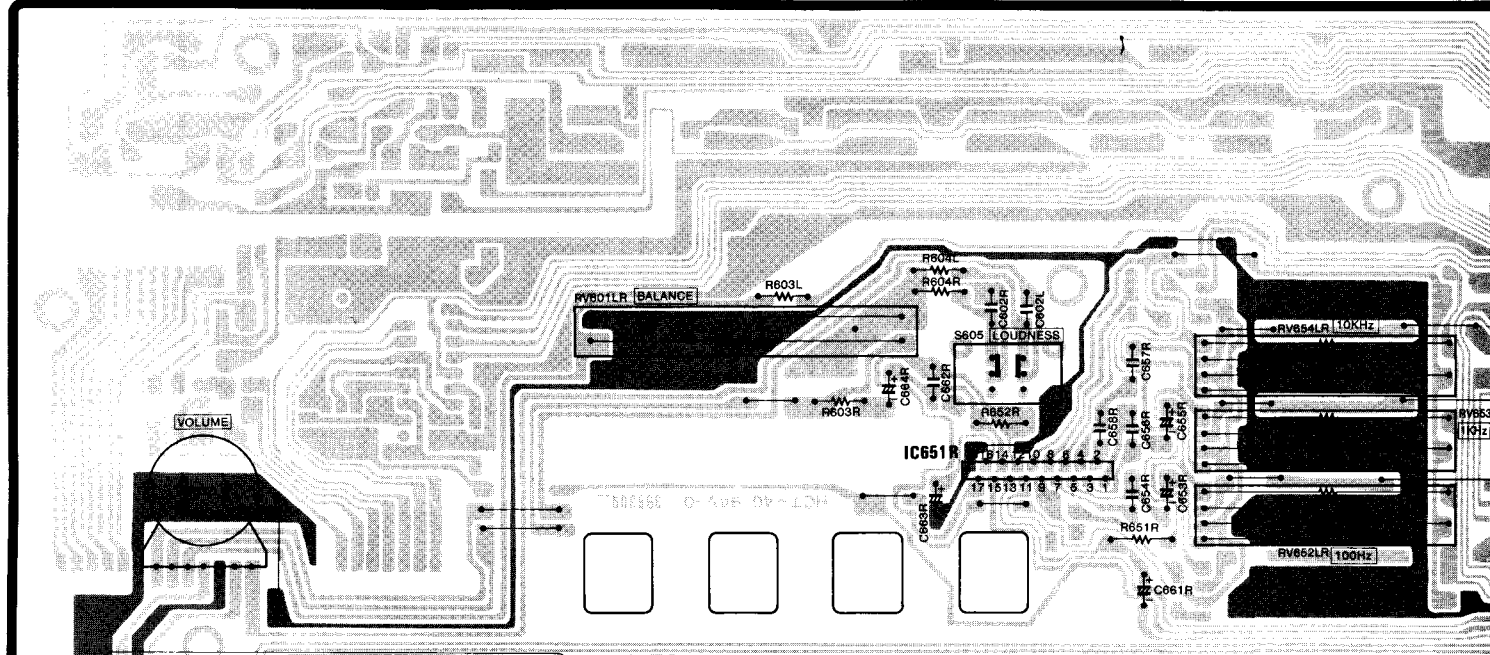

PA P.W.B.(for MD18)[except EW]

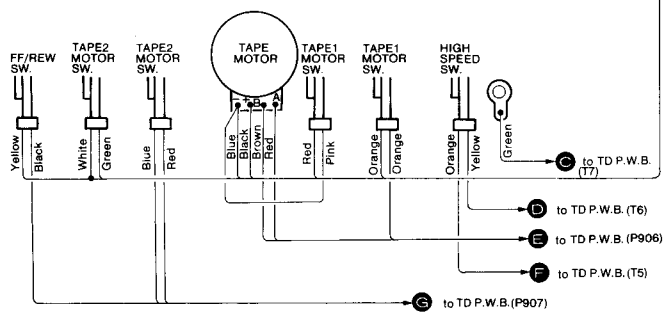
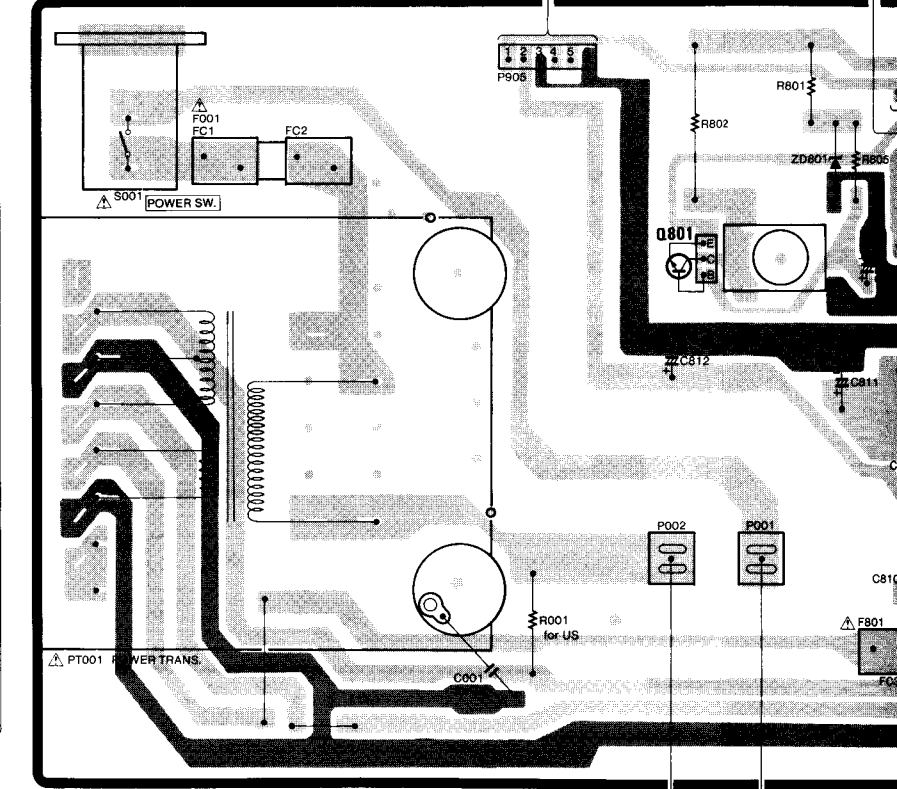

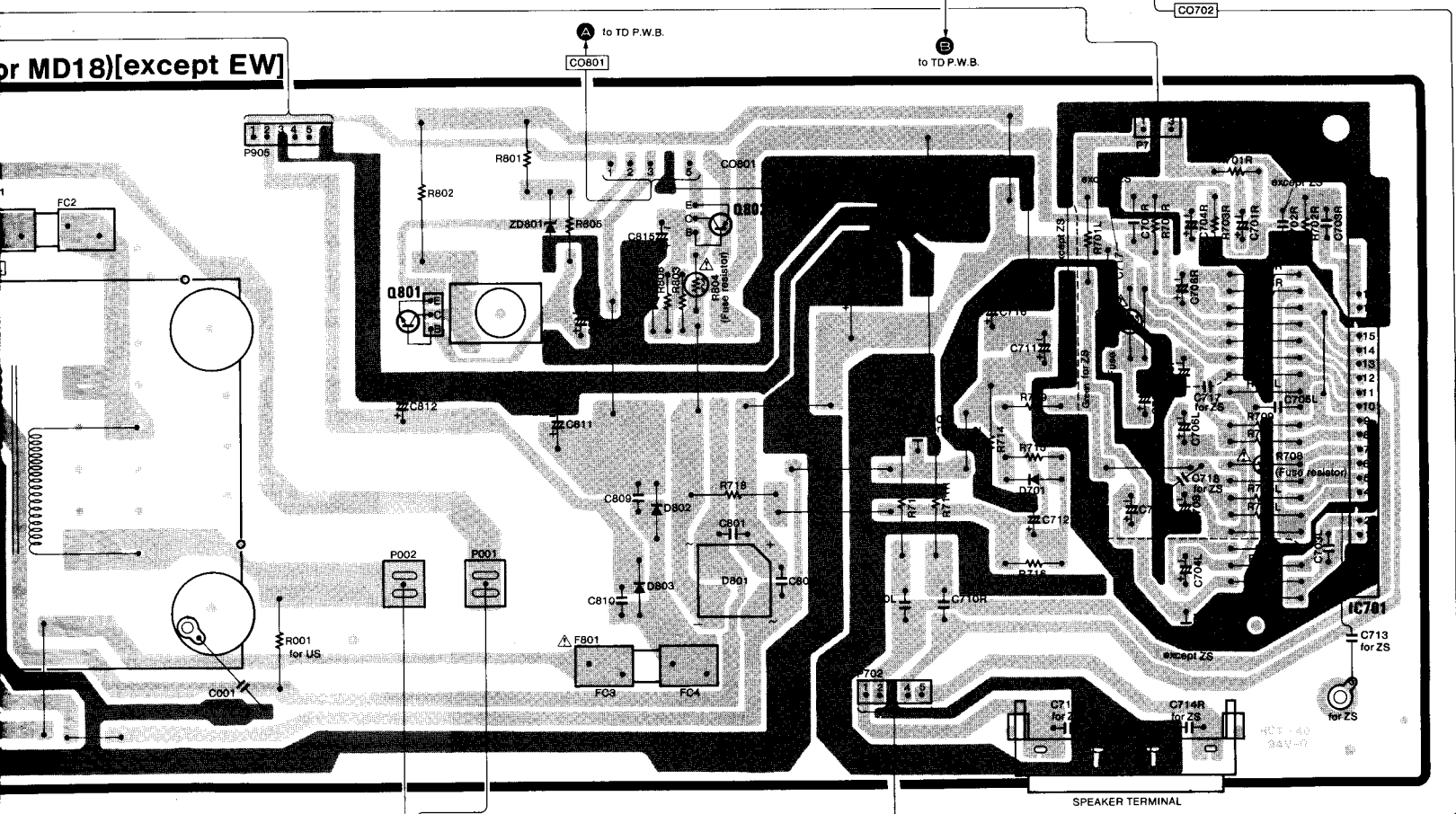
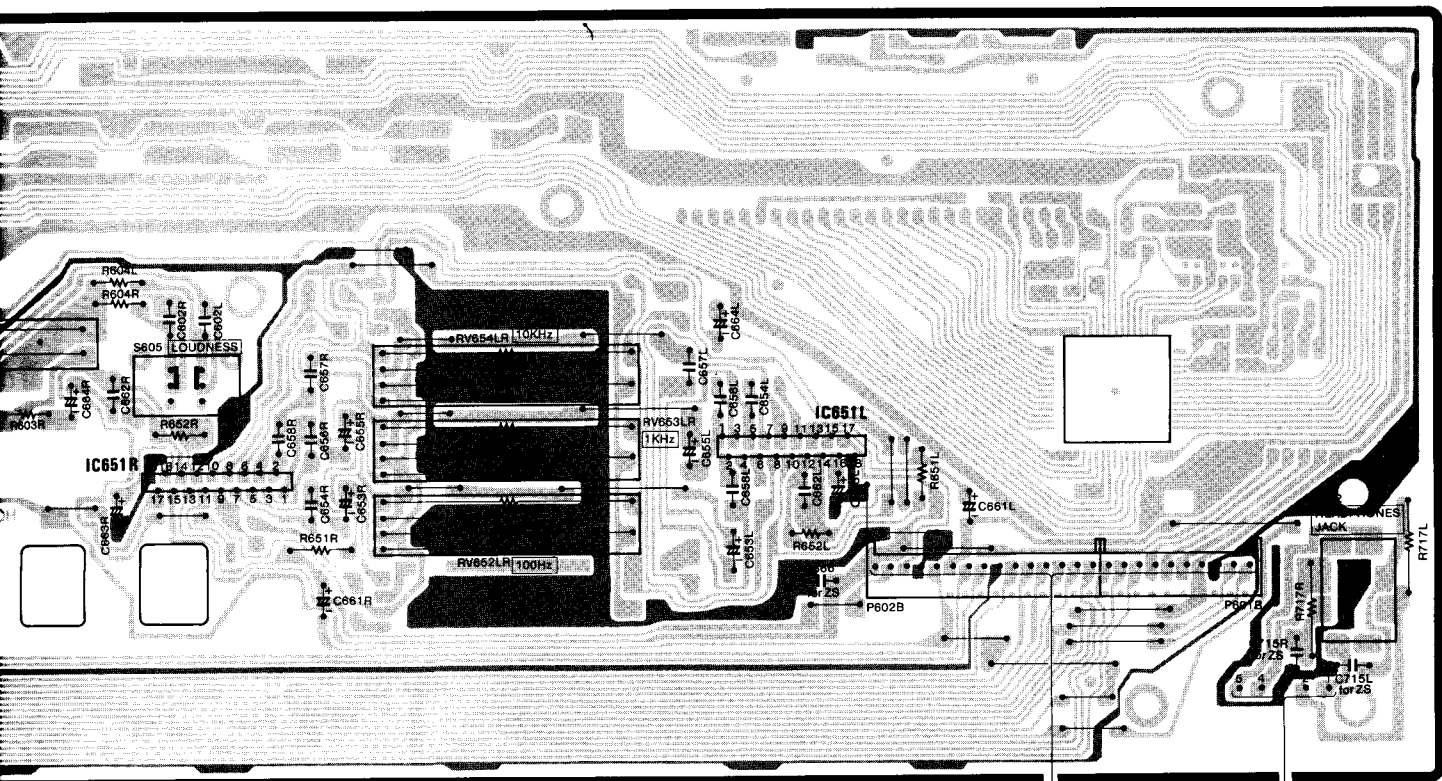

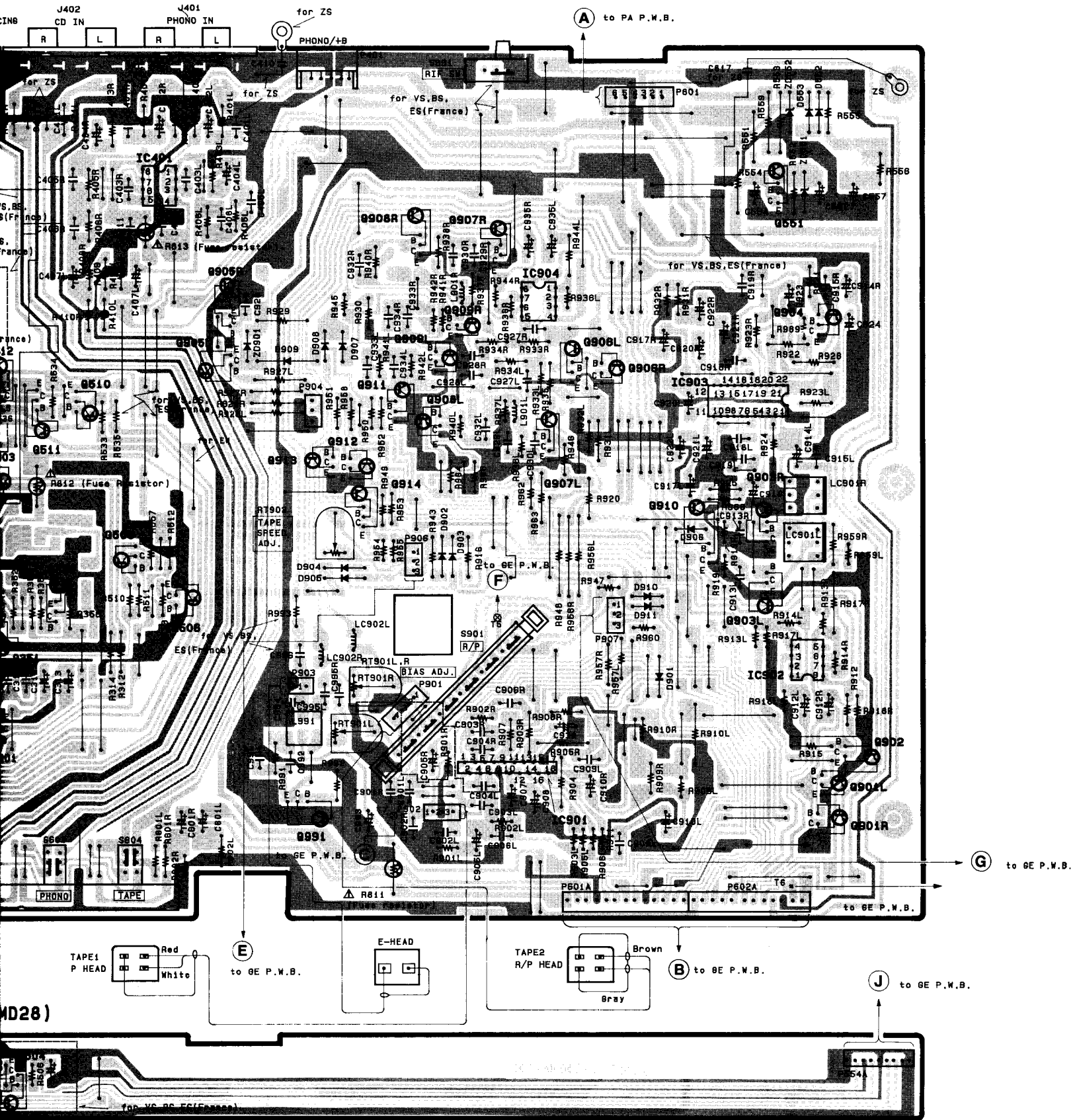

MD28)

GE P.W.B. (for MD28) (for EW)

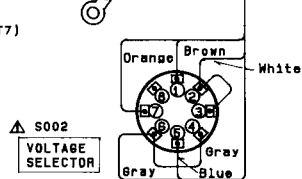
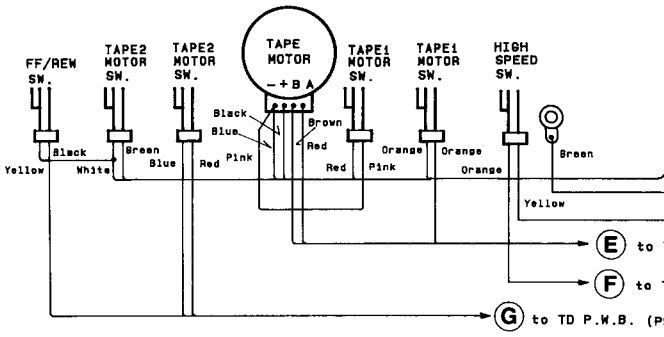
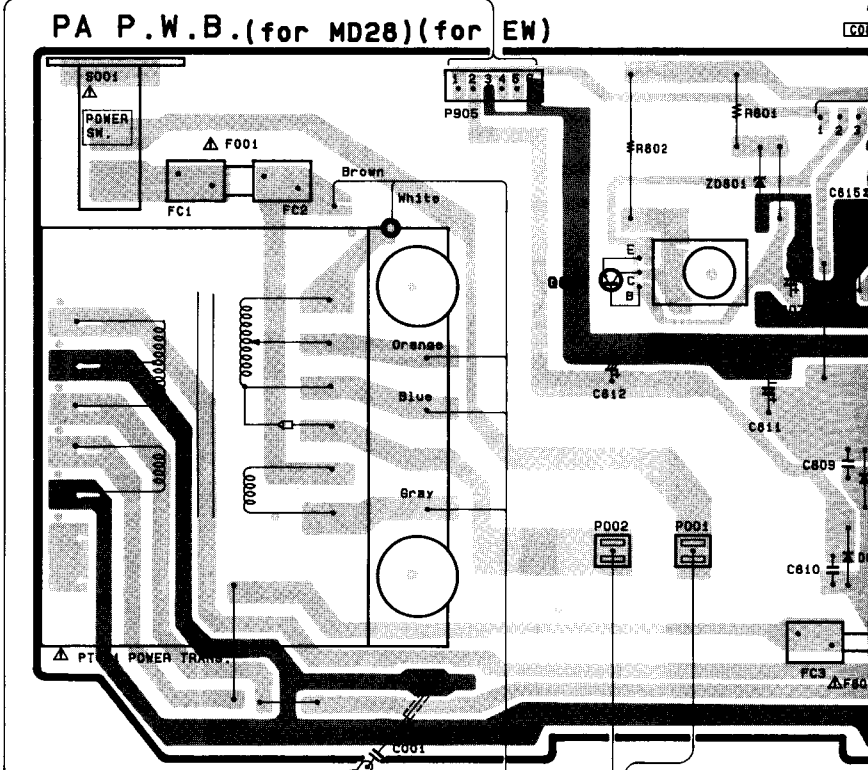
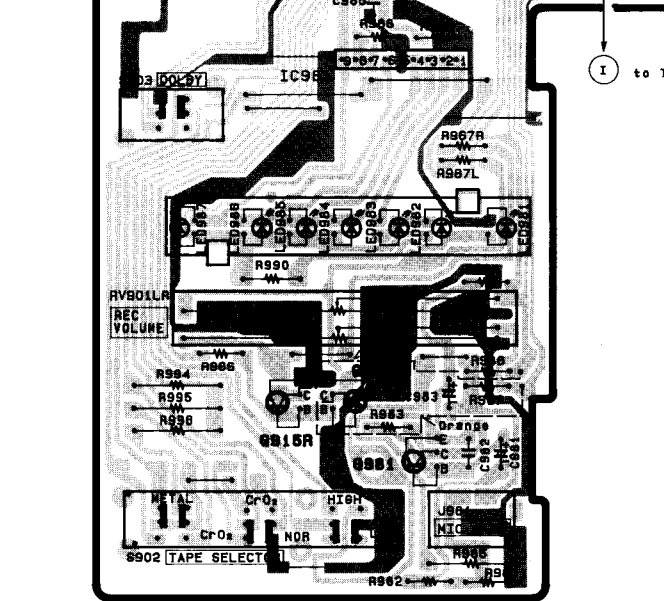
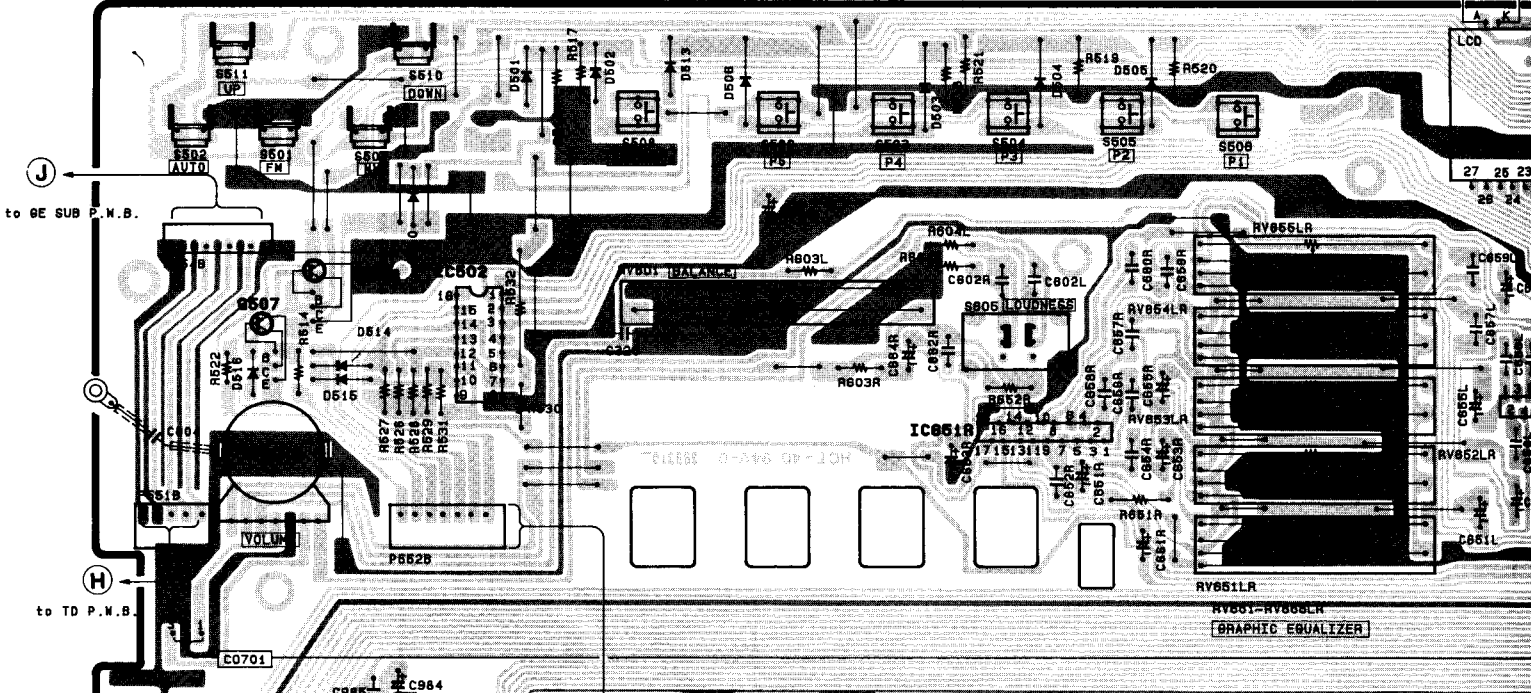

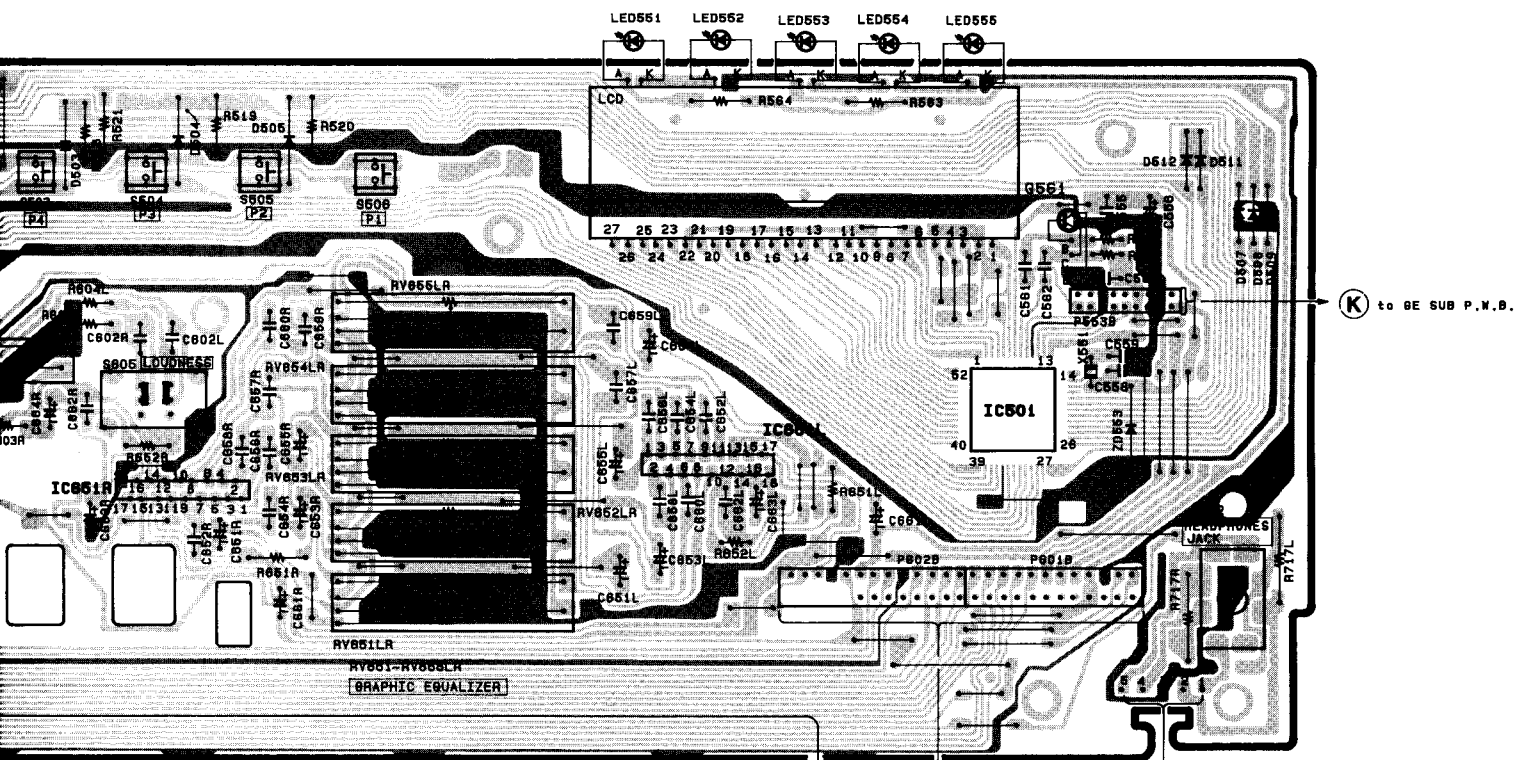

.B.(for MD28)(for EW)

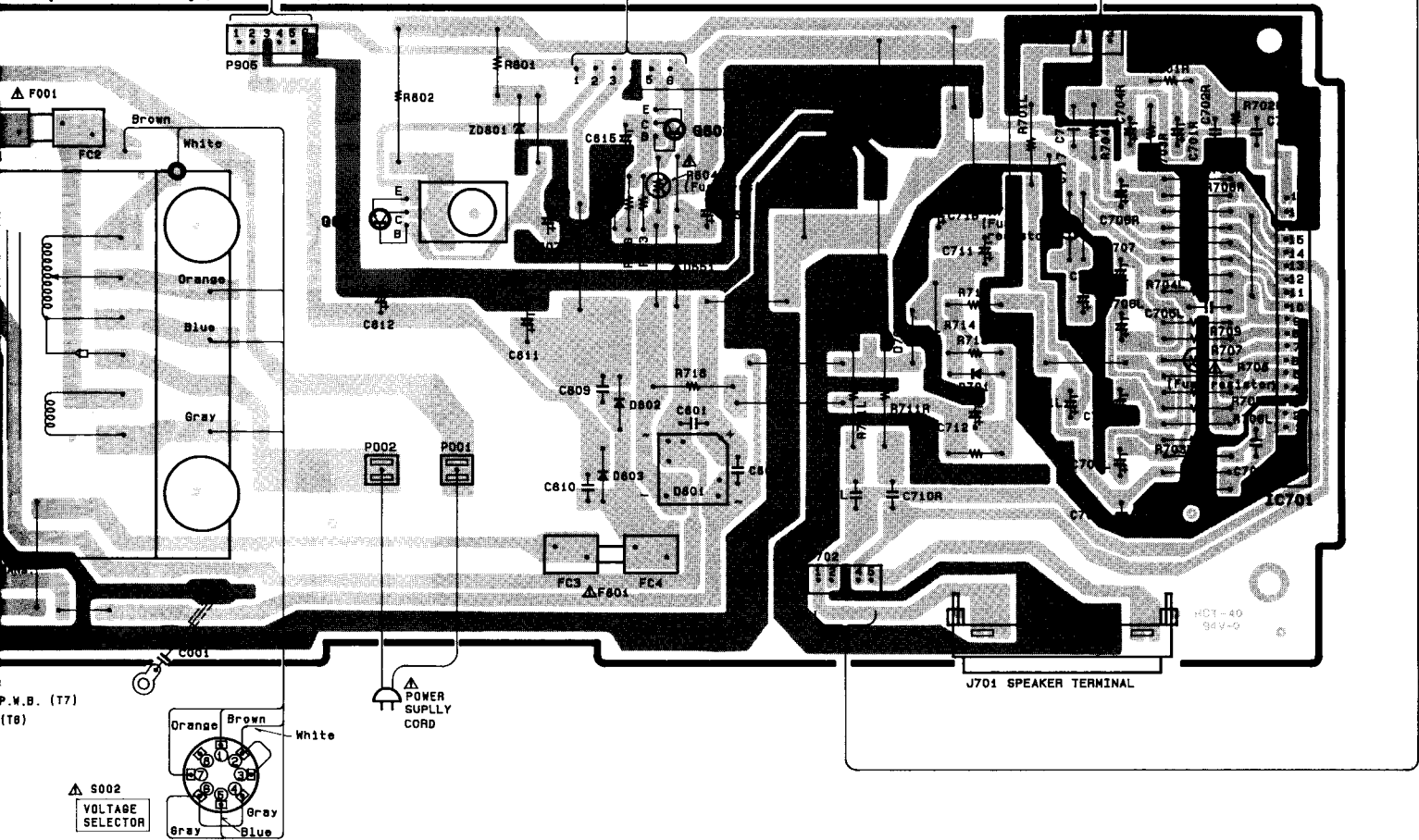

GE P.W.B. (for MD28)(except EW)

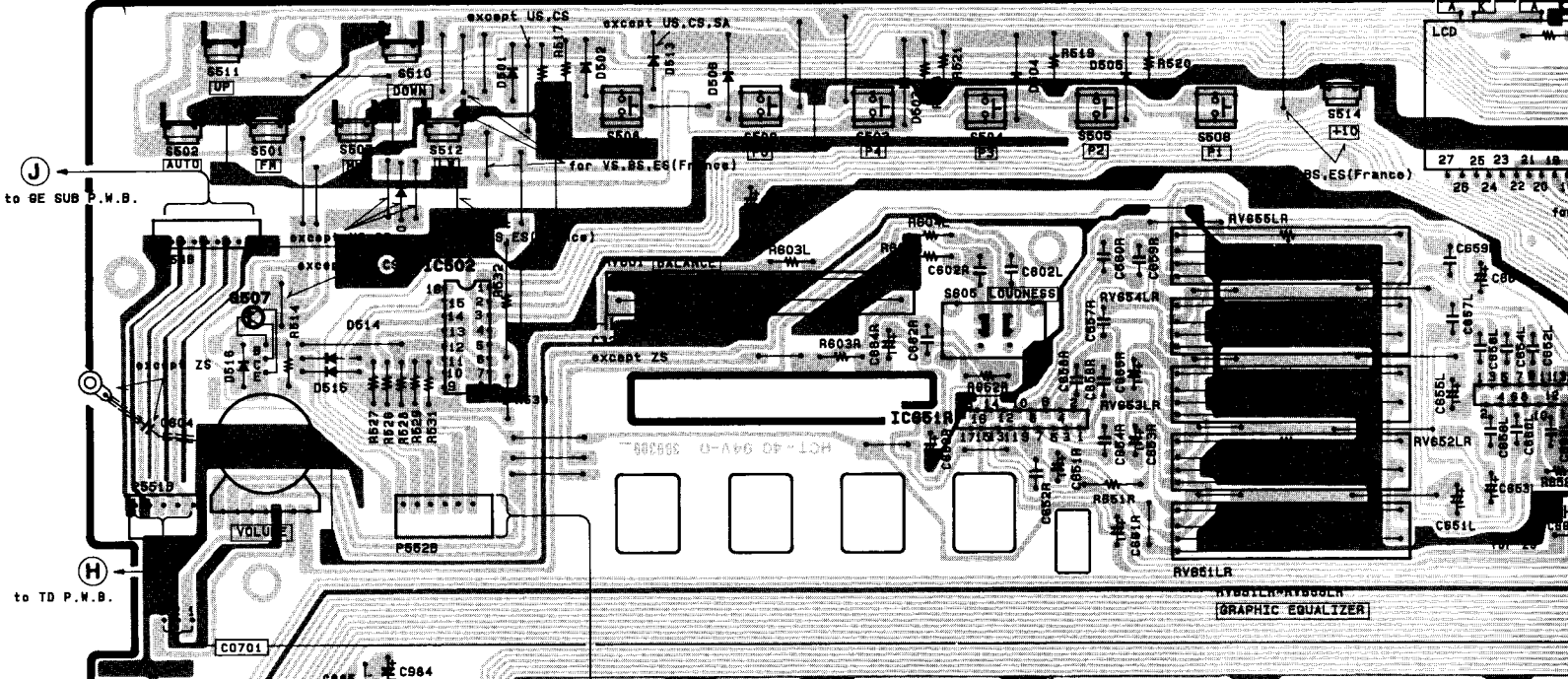

to GE SUB P.W.B.

to TD P.W.B.

I to TD P.W.B.

to TD P.W.B.

PA P.W.B. (for MD28)(except EW)

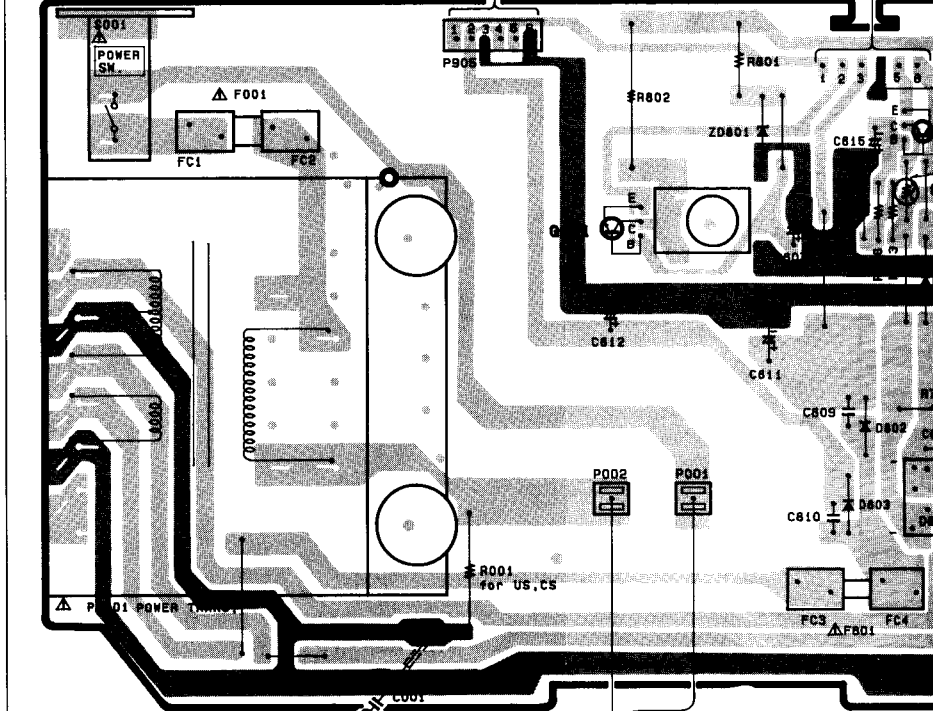

to TD P.W.B.

POWER SW

F001

FC1

FC2

P908

R801

ZD801

C815

P002

P001

R001 for US,CS

FC3

F801

FC4

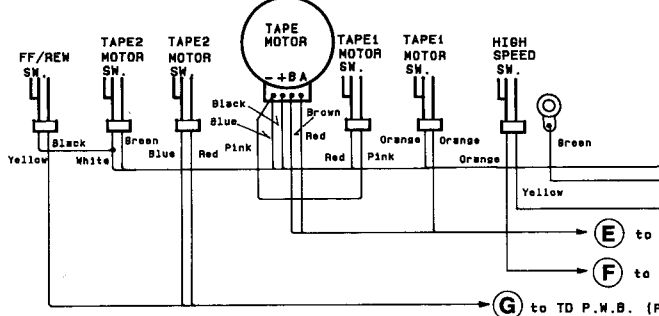

C to TD P.W.B. except ZS (T7)

D to TD P.W.B. (P906)

E to TD P.W.B. (T5)

G to TD P.W.B. (P907)

POWER SUPPLY CORD

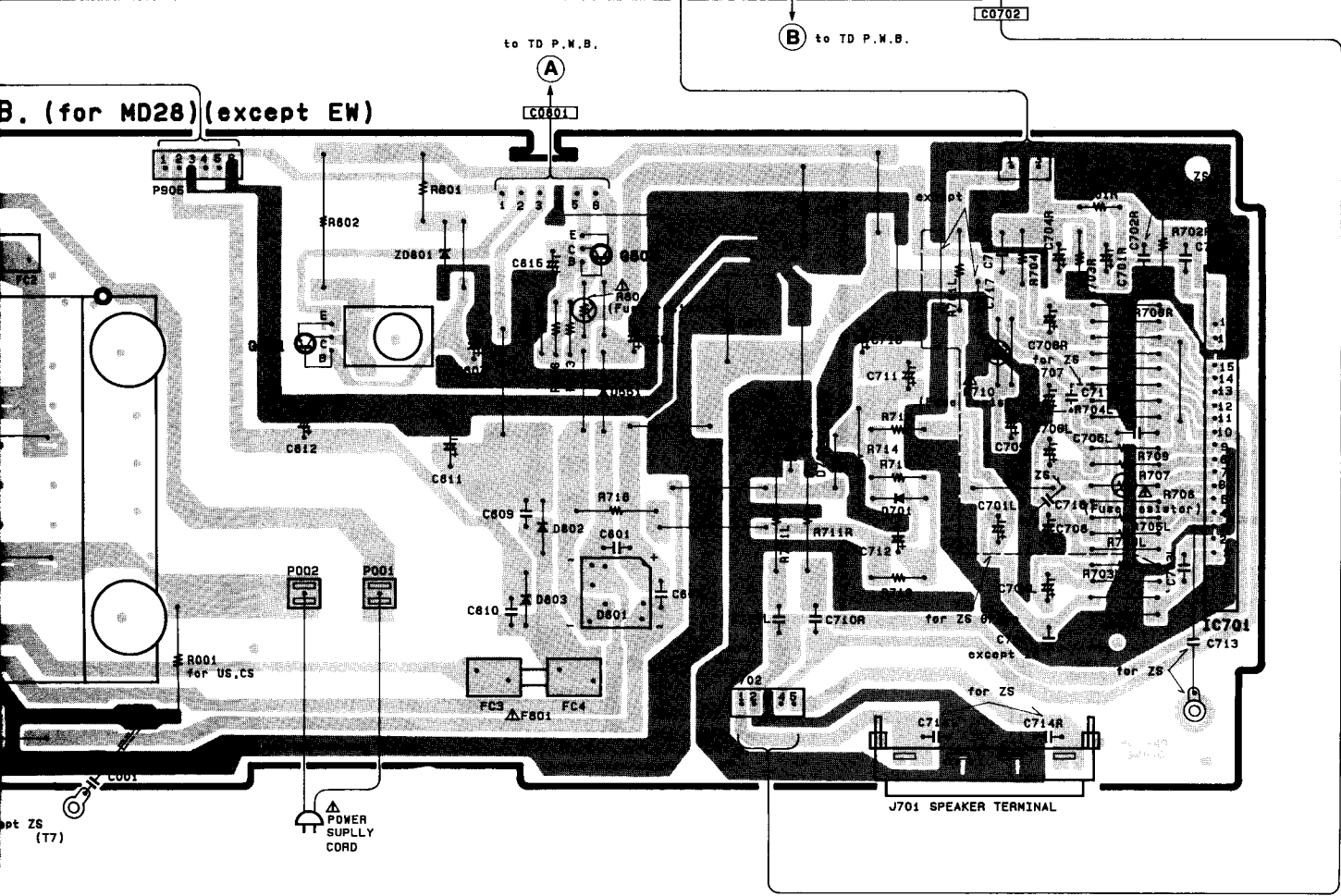
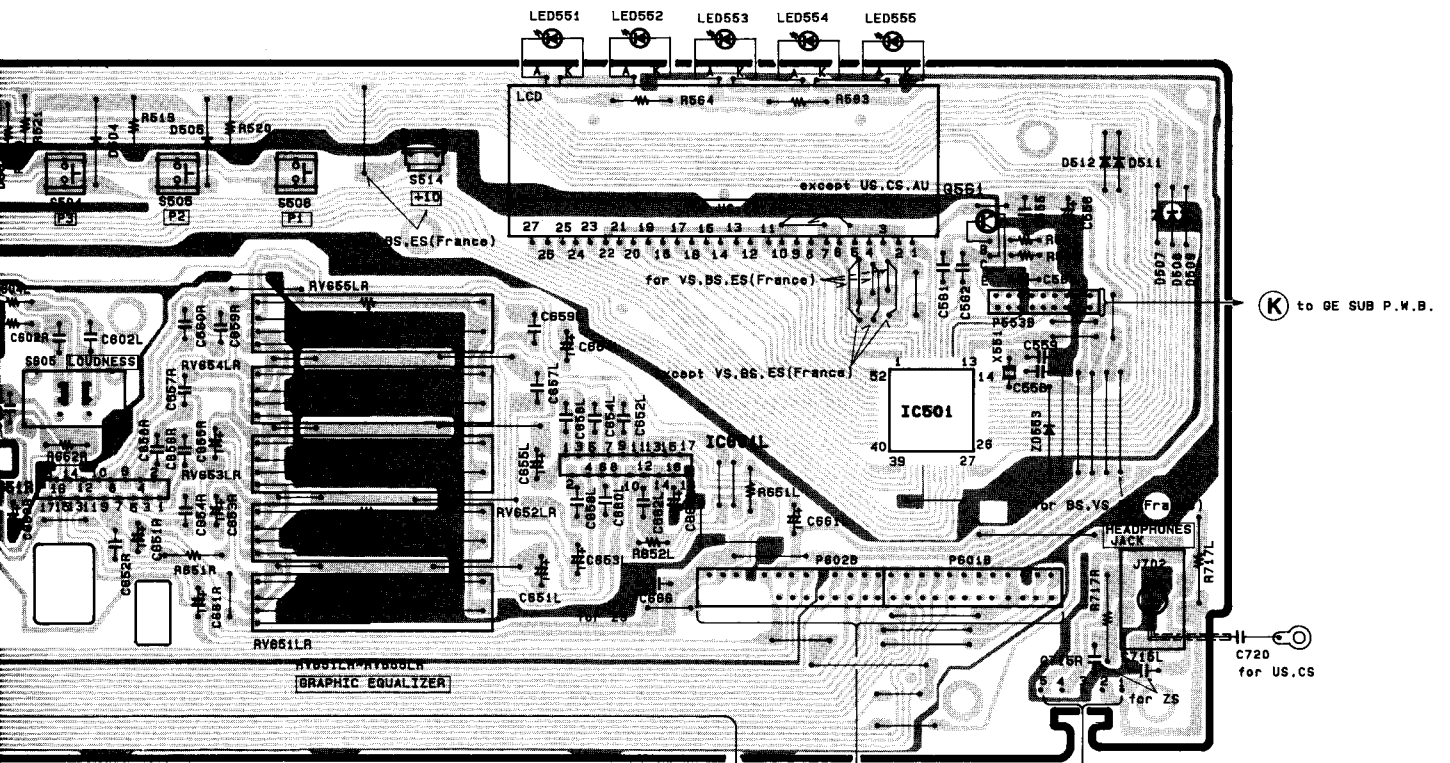

A

B

C

D

E

F

CIRCUIT DIAGRAM • DIAGRAMME DES CIRCUITS

HT-MD28

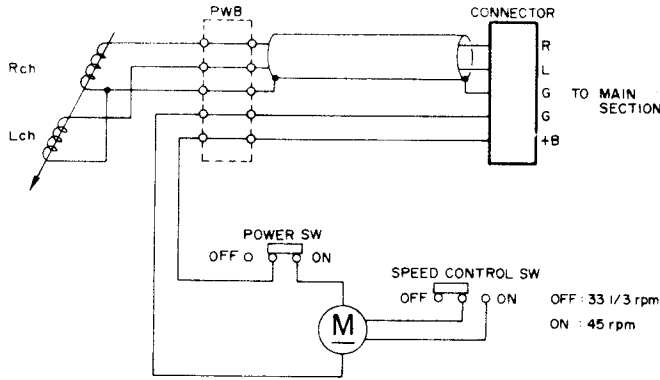

BLOCK DIAGRAM • DIAGRAMME SYNOPTIQUE

HRD-MD18

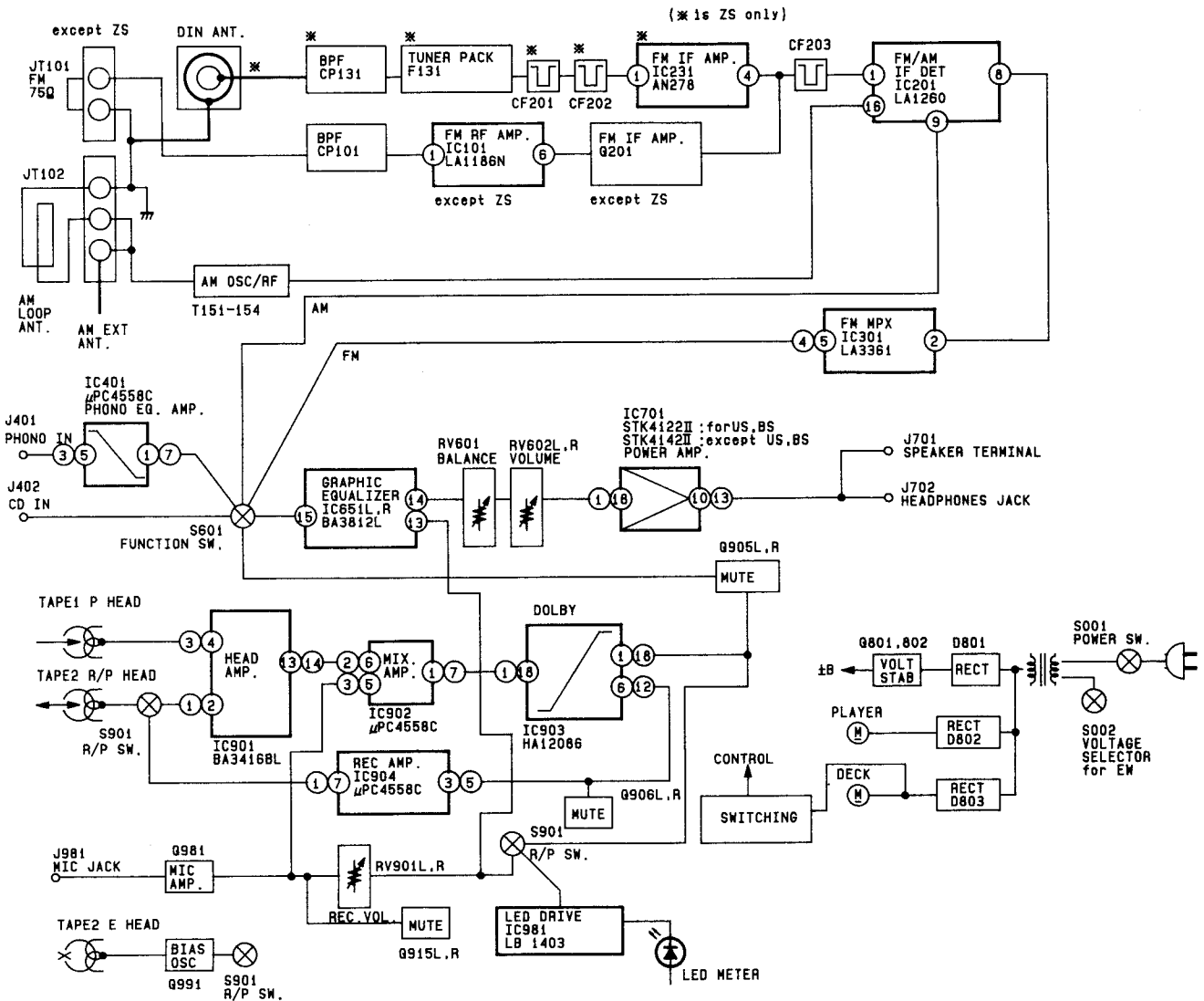

HRD-MD28

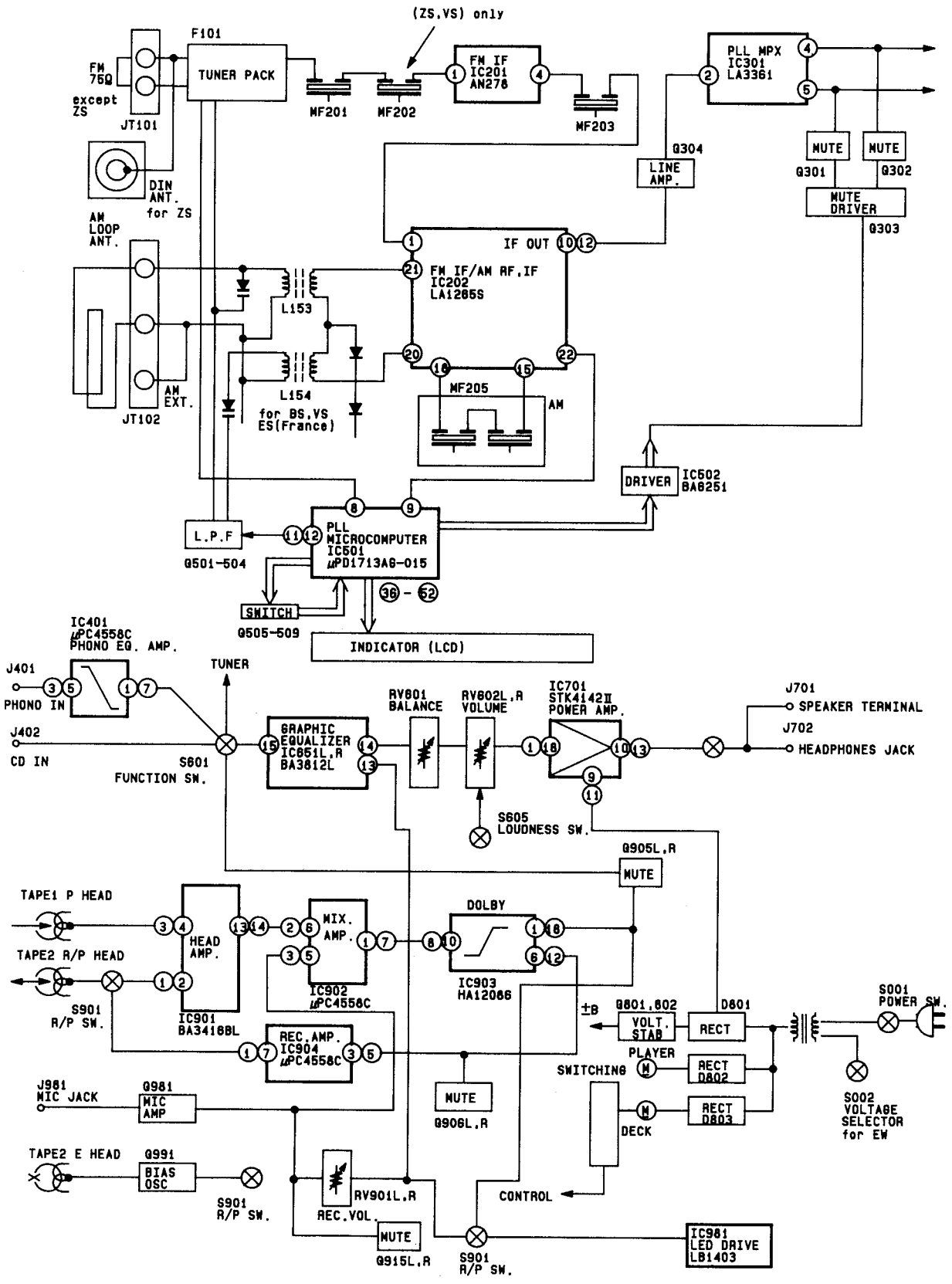

EXPLODED VIEW • VUE ECLATEE

HRD-MD18

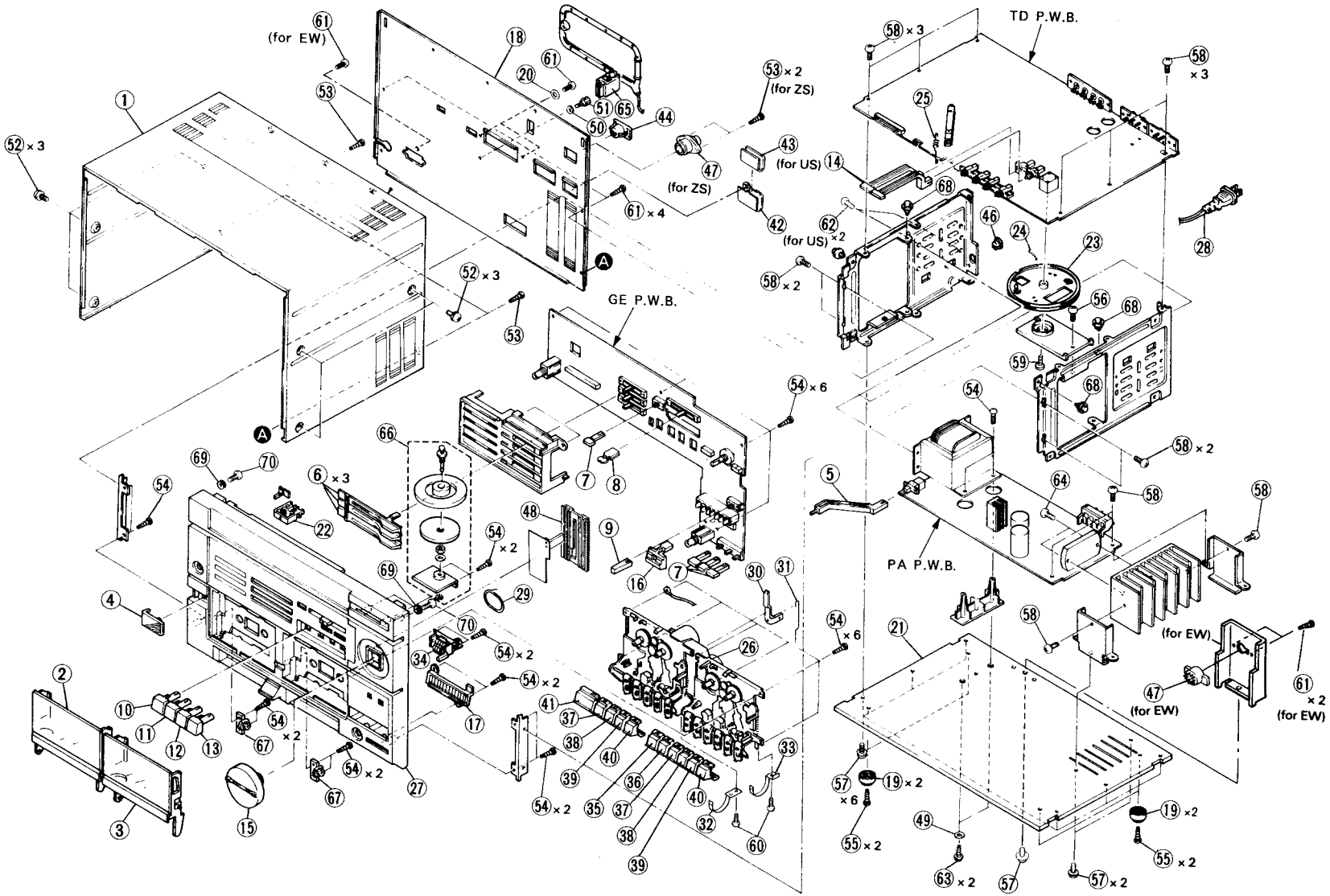

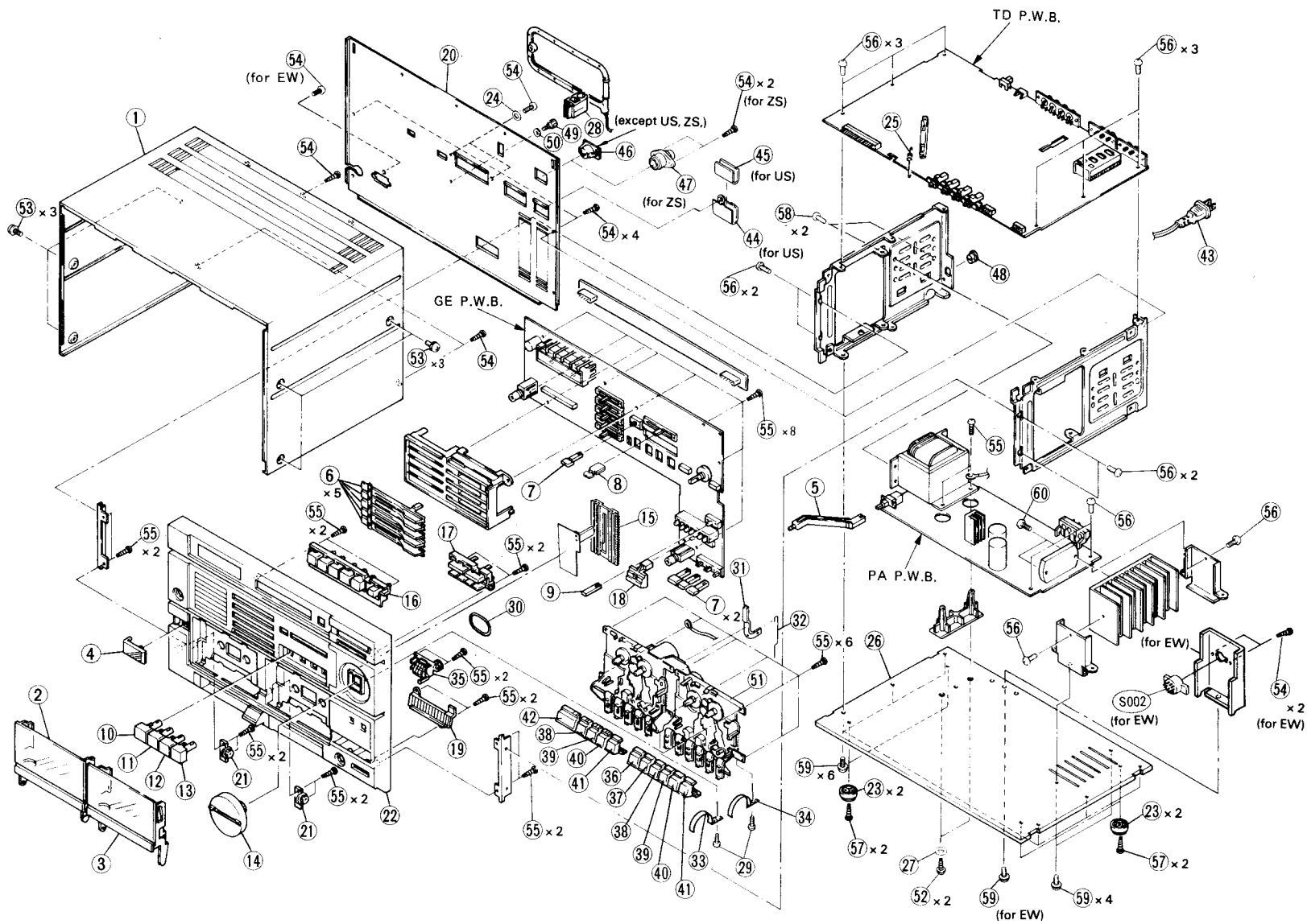

REPLACEMENT PARTS LIST

CD..... Ceramic discal

EL..... Electrolytic

ST..... Styrol

ME..... Metal

CO..... Composition

CC..... Cylindrical ceramic

MF..... Mylar, film

CF..... Carbon film

MO..... Metal, oxide

FR..... Fuse resistor

HRD-MD18

SYMBOL NO.	PART NO.	DESCRIPTION	SYMBOL NO.	PART NO.	DESCRIPTION	SYMBOL NO.	PART NO.	DESCRIPTION
CAPACITORS								
C001	0244109	CD 4700pF ±10% 50V [for ZS]	C206	0208524	CD 470pF ±5% 50V	C601L,R	0252811	EL 1μF 50V
C002	0244173	CD 0.022μF $\pm\frac{80}{20}\%$ 50V [for ZS]	C207	0240218	CD 0.033μF ±10% 25V	C602L,R	0240214	CD 0.015μF ±10% 25V
C101	0209731	CD 1000pF ±10% 50V [except ZS]	C208	0244173	CD 0.022μF $\pm\frac{80}{20}\%$ 50V	C653L,R	0252811	EL 1μF 50V
C102	0209731	CD 1000pF ±10% 50V [except ZS]	C209	0208692	CD 220pF ±5% 50V	C654L,R	0240217	CD 0.027μF ±10% 25V
C103	0248664	CD 15pF ±5% 50V [for US]	C210	0208676	CD 47pF ±5% 50V	C655L,R	0252801	EL 0.1μF 50V
	0248667	CD 20pF ±5% 50V [for EW, SA, KS]	C211	0208526	CD 560pF ±5% 50V	C656L,R	0240205	CD 2700pF ±10% 25V
	0248669	CD 24pF ±5% 50V [for ES, BS]	C212	0244173	CD 0.022μF $\pm\frac{80}{20}\%$ 50V	C657L,R	0244171	CD 0.01μF $\pm\frac{80}{20}\%$ 50V
C105	0209731	CD 1000pF ±10% 50V [except ZS]	C213	0252521	EL 10μF 16V	C658L,R	0208694	CD 270pF ±5% 50V
C107	0246451	CD 30pF ±5% 50V [except ZS]	C214	0208692	CD 220pF ±5% 50V [except ZS]	C661L,R	0252813	EL 3.3μF 50V
C109	0248176	CD 18pF ±5% 50V [for BS, ES, ZS]	C215	0244173	CD 0.022μF $\pm\frac{80}{20}\%$ 50V [except ZS]	C662L,R	0209731	CD 1000pF ±10% 50V
	0248177	CD 20pF ±5% 50V [for BS, ES]	C216	0209736	CD 6800pF ±10% 50V	C663L,R	0252522	EL 22μF 16V
C112	0244101	CD 1000pF ±10% 50V [except ZS]	C231	0244173	CD 0.022μF $\pm\frac{80}{20}\%$ 50V [for ZS]	C664L,R	0252813	EL 3.3μF 50V
C131	0275015	MF 0.047μF ±10% 50V [for ZS]	C232	0244173	CD 0.022μF $\pm\frac{80}{20}\%$ 50V [for ZS]	C666	0244173	EL 0.022μF 16V [for ZS]
C132	0252802	EL 0.22μF 50V [for ZS]	C233	0244173	CD 0.022μF $\pm\frac{80}{20}\%$ 50V [for ZS]	C701L,R	0252813	EL 3.3μF 50V
C133	0252811	EL 1μF 50V [for ZS]	C234	0244171	CD 0.01μF $\pm\frac{80}{20}\%$ 50V [for ZS]	C702L,R	0208692	CD 220pF ±5% 50V [except ZS]
C134	0244173	CD 0.022μF $\pm\frac{80}{20}\%$ 50V [for ZS]	C301	0252335	EL 470μF 10V	C703L,R	0208696	CD 330pF ±5% 50V [except ZS]
C135	0208674	CD 39pF ±5% 50V [for ZS]	C303	0240210	CD 6800pF ±10% 25V	C704L,R	0252225	EL 47μF 6.3V
C136	0208674	CD 39pF ±5% 50V [for ZS]	C304	0240210	CD 6800pF ±10% 25V	C705L,R	0230612	CC 10pF ±5% 50V
C137	0244173	CD 0.022μF $\pm\frac{80}{20}\%$ 50V [for ZS]	C305	0209733	CD 2200pF ±10% 50V [except US]	C706L,R	0252625	EL 47μF 25V
C138	0248672	CD 33pF ±5% 50V [for ZS]	C305	0209736	CD 6800pF ±10% 50V [for US]	C707	0252825	EL 47μF 50V
C151	0208650	CD 10pF ±0.5pF 50V [for ZS]	C306	0209733	CD 2200pF ±10% 50V [except US]	C708	0252825	EL 47μF 50V
C152	0246446	CD 18pF ±5% 50V [except BS, ES]	C306	0209736	CD 6800pF ±10% 50V [for US]	C709	0252825	EL 47μF 50V
C152	0246444	CD 15pF ±5% 50V [for ES, BS]	C307	0252805	EL 0.47μF 50V	C710L,R	0276011	MF 0.1μF ±10% 50V
C153	0268321	PP 360pF ±5% 100V	C308	0252805	EL 0.47μF 50V	C711	0255011	EL 47μF 50V
C155	0208681	CD 75pF ±5% 50V [for ES, BS]	C309	0252815	EL 4.7μF 50V	C712	0255011	EL 47μF 50V
C156	0246464	CD 100pF ±5% 50V [for ES, BS]	C310	0275015	MF 0.047μF ±10% 50V	C713	0244171	CD 0.01μF 50V [for ZS]
C157	0246468	CD 150pF ±5% 50V [for ES, BS]	C311	0268446	PP 0.001μF ±5% 100V	C714L,R	0244173	CD 0.022μF 50V [for ZS]
C158	0246429	CD 9pF ±0.25pF 50V [for ES, BS]	C312	0252805	EL 0.47μF 50V	C715L,R	0244171	CD 0.01μF 50V [for ZS]
C160	0244173	CD 0.022μF $\pm\frac{80}{20}\%$ 50V	C313	0252805	EL 0.47μF 50V	C716	0255011	EL 47μF 50V
C203	0244173	CD 0.022μF $\pm\frac{80}{20}\%$ 50V	C314	0252813	EL 3.3μF 50V	C717	0244173	CD 0.022μF 50V
C204	0244173	CD 0.022μF $\pm\frac{80}{20}\%$ 50V	C315	0252813	EL 3.3μF 50V [for ZS]	C718	0244173	CD 0.022μF 50V [for ZS]
C205	0252335	EL 470μF 10V	C316	0208526	CD 560pF ±5% 50V [for ZS]	C801	0244173	CD 0.022μF 50V
			C317	0208684	CD 100pF ±5% 50V [except ZS]	C802	0244173	CD 0.022μF 50V
			C401L,R	0209731	CD 1000pF ±10% 50V [for ZS]	C805	0255001	EL 4700μF 40V
			C402L,R	0252813	EL 3.3μF 50V	C806	0255001	EL 4700μF 40V
			C403L,R	0208684	CD 100pF ±5% 50V	C807	0252632	EL 220μF 25V
			C404L,R	0252325	EL 47μF 10V	C809	0244173	CD 0.022μF 50V
			C405L,R	0240211	CD 8200pF ±10% 25V	C810	0244173	CD 0.022μF 50V
			C406L,R	0240204	CD 2200pF ±10% 25V	C811	0252535	EL 470μF 16V
			C407L,R	0252813	EL 3.3μF 50V	C812	0252535	EL 470μF 16V
			C409	0244171	CD 0.01μF $\pm\frac{80}{20}\%$ 50V	C815	0252625	EL 47μF 25V
			C410	0244171	CD 0.01μF $\pm\frac{80}{20}\%$ 50V [for ZS]	C817	0244171	CD 0.01μF 50V [for ZS]
			C411	0244171	CD 0.01μF $\pm\frac{80}{20}\%$ 50V	C901L,R	0209731	CD 1000pF ±10% 50V
			C421L,R	0208692	CD 220pF ±5% 50V [for ZS]	C902L,R	0209731	CD 1000pF ±10% 50V
						C903L,R	0248736	CD 330pF ±10% 50V
						C904L,R	0248736	CD 330pF ±10% 50V
						C905L,R	0252231	EL 100μF 6.3V
						C906L,R	0240218	CD 0.033μF ±10% 25V
						C907	0252522	EL 22μF 16V
						C908	0252525	EL 47μF 16V

■ Cassette chassis

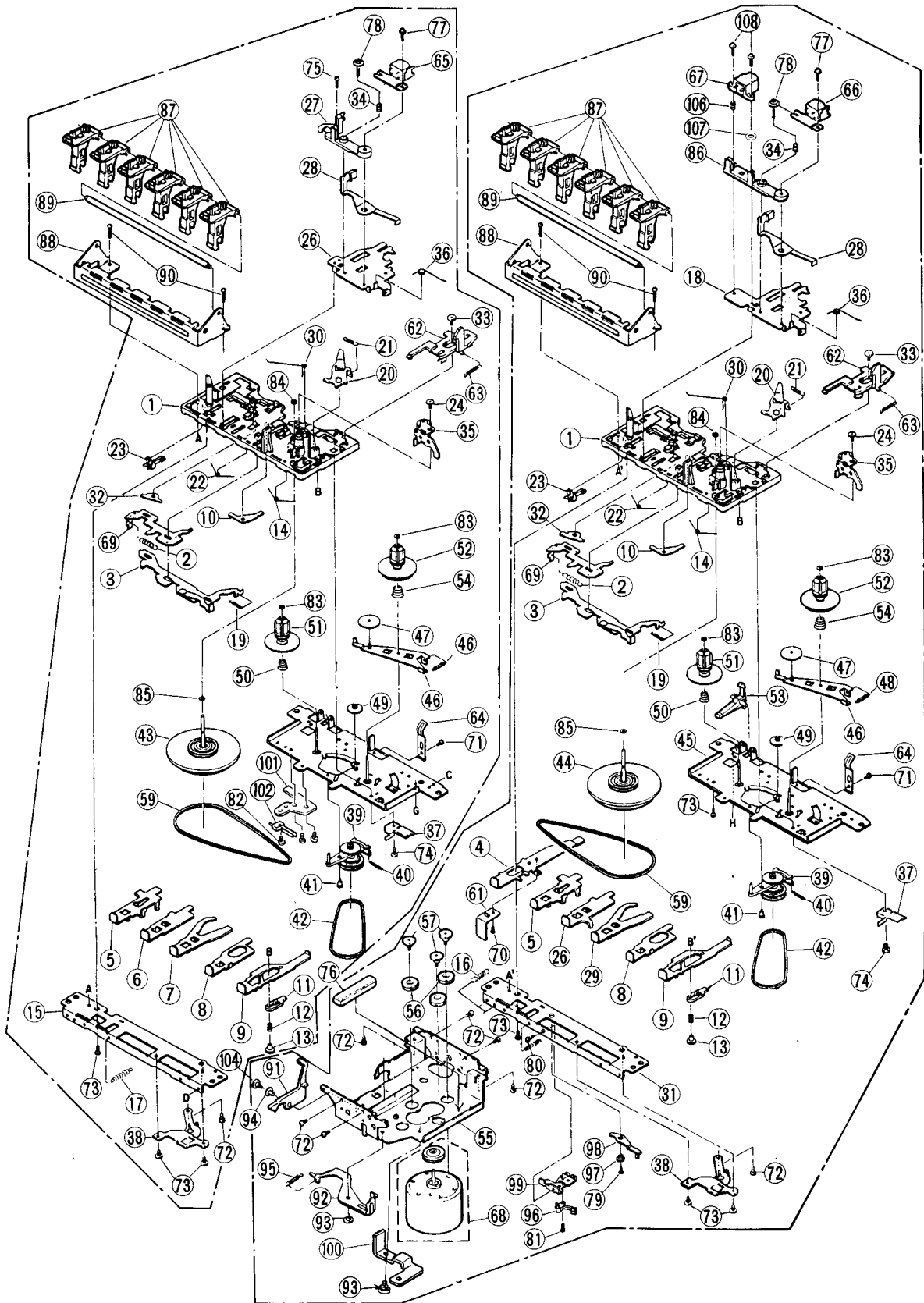

HT-MD28

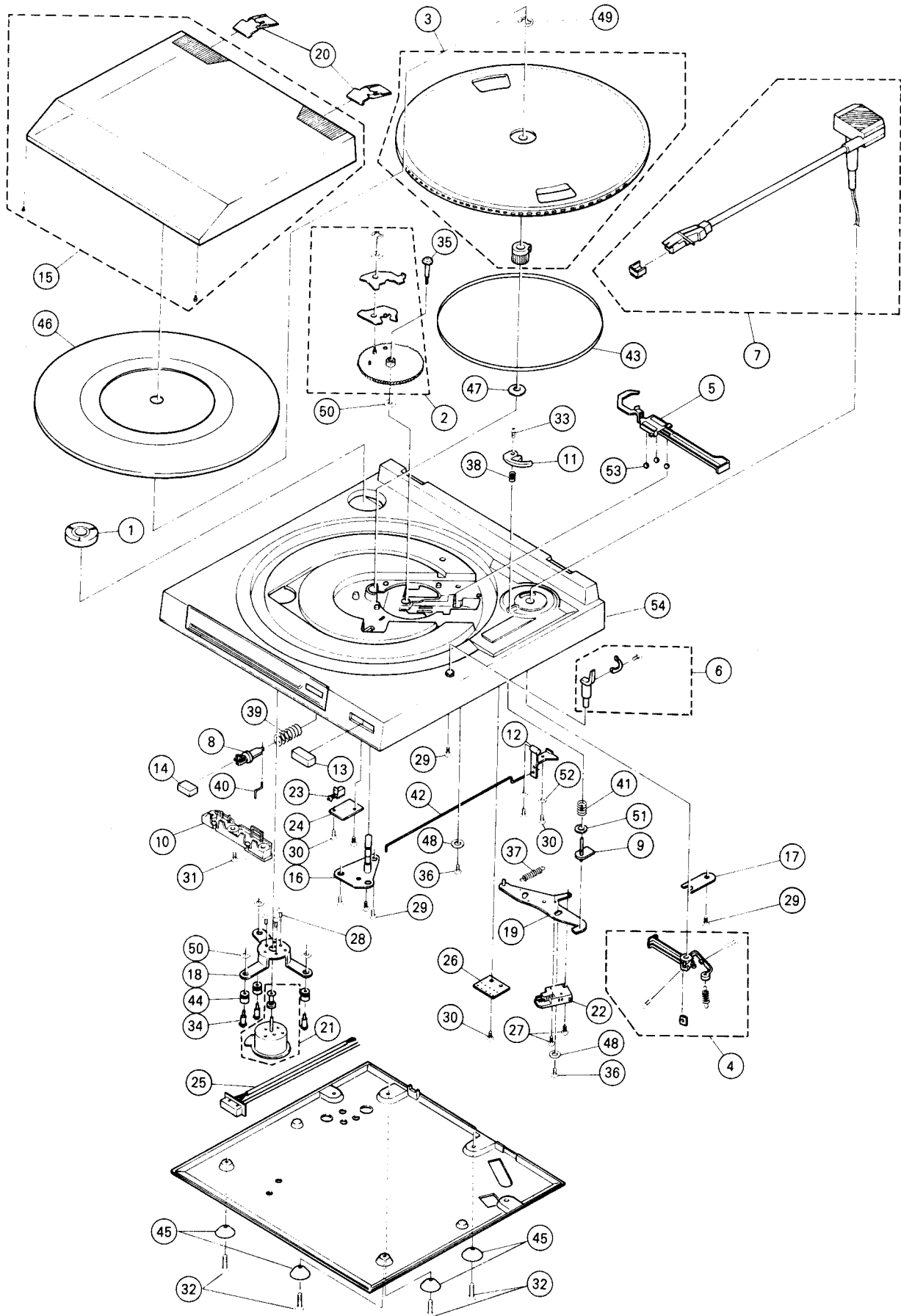

SYMBOL NO.	PART NO.	DESCRIPTION	SYMBOL NO.	PART NO.	DESCRIPTION	SYMBOL NO.	PART NO.	DESCRIPTION
C909L,R	0240216	CD 0.022μF ±10% 25V	R205	0113635	CF 6.8kΩ ±5% SRD1/6P	R719	0113639	CF 10kΩ ±5% SRD1/6P
C910L,R	0252813	EL 3.3μF 50V	R206	0113603	CF 330Ω ±5% SRD1/6P [except ZS]	R801	0129615	CF 3.9kΩ ±5% SRD1/4P
C912L,R	0252813	EL 3.3μF 50V	R207	0113293	CF 330Ω ±5% SRD1/2P	R802	1119155	ME 22Ω ±10% RN2B
C913L,R	0209731	CD 1000pF ±10% 50V	R208	0113637	CF 8.2kΩ ±5% SRD1/6P	R803	0129615	CF 3.9kΩ ±5% SRD1/4P
C914L,R	0252813	EL 3.3μF 50V	R209	0113605	CF 390Ω ±5% SRD1/6P	△R804	1110625	FR 220Ω ±5% SRD1/4P
C915L,R	0209733	CD 2200pF ±10% 50V	R210	0113631	CF 4.7kΩ ±5% SRD1/6P [except ZS]	R805	0129601	CF 1kΩ ±5% SRD1/4P
C916	0252813	EL 3.3μF 50V	R211	0113605	CF 390Ω ±5% SRD1/6P [except ZS]	R806	0129607	CF 1.8kΩ ±5% SRD1/4P
C917L,R	0252813	EL 3.3μF 50V	R231	0113603	CF 330Ω ±5% SRD1/6P [for ZS]	△R811	1110601	FR 10Ω ±5% RN1/4B
C918L,R	0240212	CD 0.01μF ±10% 25V	R232	0113615	CF 1kΩ ±5% SRD1/6P [for ZS]	△R813	1110601	FR 10Ω ±5% RN1/4B
C919L,R	0240214	CD 0.015μF ±10% 25V	R233	0113605	CF 390Ω ±5% SRD1/6P [for ZS]	R901L,R	0113579	CF 33Ω ±5% SRD1/6P
C920L,R	0252807	EL 0.68μF 50V	R234	0113619	CF 1.5kΩ ±5% SRD1/6P [for ZS]	R902L,R	0113663	CF 100kΩ ±5% SRD1/6P
C921L,R	0252812	EL 2.2μF 50V	R301	0113613	CF 820 ±5% SRD1/6P	R903L,R	0113629	CF 3.9kΩ ±5% SRD1/6P
C922L,R	0252813	EL 3.3μF 50V	R302	0113633	CF 5.6kΩ ±5% SRD1/6P	R904	0113625	CF 2.7kΩ ±5% SRD1/6P
C923	0252232	EL 220μF 6.3V	R303	0113633	CF 5.6kΩ ±5% SRD1/6P	R905L,R	0113623	CF 2.2kΩ ±5% SRD1/6P
C924	0252531	EL 100μF 16V	R304	0113631	CF 4.7kΩ ±5% SRD1/6P	R906L,R	0113627	CF 3.3kΩ ±5% SRD1/6P
C926	0209737	CD 0.01μF ±10% 50V	R305	0113631	CF 4.7kΩ ±5% SRD1/6P	R907	0113651	CF 33kΩ ±5% SRD1/6P
C927L,R	0240218	CD 0.033μF ±10% 25V	R306	0113663	CF 100kΩ ±5% SRD1/6P	R909L,R	0113637	CF 8.2kΩ ±5% SRD1/6P
C928L,R	0209721	CD 339pF ±10% 50V	R307	0113663	CF 100kΩ ±5% SRD1/6P	R910L	0113641	CF 12kΩ ±5% SRD1/6P
C929L,R	0240212	CD 0.01μF ±10% 25V	R308	0113609	CF 560Ω ±8% SRD1/6P	R910R	0113639	CF 10kΩ ±5% SRD1/6P
C930L,R	0240215	CD 0.018μF ±10% 25V	R309	0113635	CF 6.8kΩ ±5% SRD1/6P	R911	0113639	CF 10kΩ ±5% SRD1/6P
C932L,R	0240221	CD 0.056μF ±10% 25V	R310	0113615	CF 1kΩ ±5% SRD1/6P	R912	0113651	CF 33kΩ ±5% SRD1/6P
C935L,R	0252813	EL 3.3μF 50V	R311	0113619	CF 1.5kΩ ±5% SRD1/6P	R913L,R	0113639	CF 10kΩ ±5% SRD1/6P
C936	0252522	EL 22μF 16V	R331	0113647	CF 22kΩ ±5% SRD1/6P [for ZS]	R914L,R	0113639	CF 10kΩ ±5% SRD1/6P
C981	0252813	EL 3.3μF 50V	R341	0113621	CF 1.8kΩ ±5% SRD1/6P	R915	0113651	CF 33kΩ ±5% SRD1/6P
C982	0209723	CD 470pF ±10% 50V	R401L,R	0113623	CF 2.2kΩ ±5% SRD1/6P	R916	0113639	CF 10kΩ ±5% SRD1/6P
C983	0252813	EL 3.3μF 50V	R402L,R	0113655	CF 47kΩ ±5% SRD1/6P	R917L,R	0113627	CF 3.3kΩ ±5% SRD1/6P
C984	0252521	EL 10μF 16V	R403L,R	0113619	CF 1.5kΩ ±5% SRD1/6P	R918L,R	0113639	CF 10kΩ ±5% SRD1/6P
C985	0208686	CD 120pF ±10% 50V	R405L,R	0113677	CF 390kΩ ±5% SRD1/6P	R919L,R	0113663	CF 100kΩ ±5% SRD1/6P
C991	0274016	MF 6800pF ±10% 50V	R406L,R	0113651	CF 33kΩ ±5% SRD1/6P	R920	0113647	CF 22kΩ ±5% SRD1/6P
C992	0275012	MF 0.015μF ±10% 50V	R408L,R	0113661	CF 82kΩ ±5% SRD1/6P	R921	0113647	CF 22kΩ ±5% SRD1/6P
C993	0252525	EL 47μF 16V	R409	0113631	CF 4.7kΩ ±5% SRD1/6P	R922	0113639	CF 10kΩ ±5% SRD1/6P
C994	0268435	PP 0.015μF ±5% 100V	R410L,R	0113615	CF 1kΩ ±5% SRD1/6P	R923L,R	0113633	CF 5.6kΩ ±5% SRD1/6P
C995L,R	0208692	CD 220pF ±5% 50V	R421L,R	0113643	CF 15kΩ ±5% SRD1/6P	R924	0113647	CF 22kΩ ±5% SRD1/6P
C996	0209732	CD 1599pF ±10% 50V [for ES, BS]	R601L,R	0113615	CF 1kΩ ±5% SRD1/6P	R925	0113647	CF 22kΩ ±5% SRD1/6P
RESISTORS			R602L,R	0113663	CF 100kΩ ±5% SRD1/6P	R926	0113291	CF 220Ω ±5% SRD1/2P
△R001	0139008	CO 2200kΩ ±10% RC1/2GF [for US]	R603L,R	0113631	CF 4.7kΩ ±5% SRD1/6P	R927L,R	0113639	CF 10kΩ ±5% SRD1/6P
R101	0113587	CF 68 ±5% SRD1/6P [except ZS]	R604L,R	0113643	CF 15kΩ ±5% SRD1/6P	R928L,R	0113651	CF 33kΩ ±5% SRD1/6P
R102	0113599	CF 220Ω ±5% SRD1/6P [except ZS]	R651L,R	0113627	CF 3.3kΩ ±5% SRD1/6P	R929	0113631	CF 4.7kΩ ±5% SRD1/6P
R103	0113619	CF 1.5kΩ ±5% SRD1/6P [except ZS]	R652L,R	0113627	CF 3.3kΩ ±5% SRD1/6P	R930	0113657	CF 56kΩ ±5% SRD1/6P
R131	0113663	CF 100kΩ ±5% SRD1/6P [for ZS]	R701L,R	0113623	CF 2.2kΩ ±5% SRD1/6P [for ZS]	R931L,R	0113659	CF 68kΩ ±5% SRD1/6P
R132	0113663	CF 100kΩ ±5% SRD1/6P [for ZS]		0113615	CF 1k ±5% SRD1/6P [except ZS]	R932L,R	0113633	CF 5.6kΩ ±5% SRD1/6P
R133	0113591	CF 100Ω ±5% SRD1/6P [for ZS]	R702L,R	0113663	CF 100kΩ ±5% SRD1/6P	R933L,R	0113641	CF 12kΩ ±5% SRD1/6P
R134	0113639	CF 10kΩ ±5% SRD1/6P [for ZS]	R703L,R	0113607	CF 470Ω ±5% SRD1/6P [except BS, US]	R934L,R	0113631	CF 4.7kΩ ±5% SRD1/6P
R135	0113617	CF 1.2kΩ ±5% SRD1/6P [for ZS]		0113611	CF 680Ω ±5% SRD1/6P [for BS, US]	R935	0113663	CF 100kΩ ±5% SRD1/6P
R136	0113663	CF 100kΩ ±5% SRD1/6P [for ZS]	R704L,R	0113663	CF 20kΩ ±5% SRD1/6P	R936L,R	0113639	CF 10kΩ ±5% SRD1/6P
R137	0129551	CF 68Ω ±5% SRD1/4P [for ZS]	R705L,R	0129611	CF 1.7kΩ ±5% SRD1/4P	R937L,R	0113619	CF 1.5kΩ ±5% SRD1/6P
R138	0113641	CF 12kΩ ±5% SRD1/6P [for ZS]	R706L,R	0129611	CF 2.7kΩ ±5% SRD1/4P	R938L,R	0113585	CF 47Ω ±5% SRD1/6P
R139	0113625	CF 2.7kΩ ±5% SRD1/6P [for ZS]	R707	0129601	CF 1kΩ ±5% SRD1/4P	R940L,R	0113625	CF 2.7kΩ ±5% SRD1/6P
R140	0129577	CF 470Ω ±5% SRD1/4P [for ZS]	△R708	1110621	FR 100Ω ±5% RN1/4B	R943	0113639	CF 10kΩ ±5% SRD1/6P
R151	0113365	CF 1kΩ ±5% SRD1/2P	R709	0129617	CF 4.7kΩ ±5% SRD1/4P	R944L,R	0113627	CF 3.3kΩ ±5% SRD1/6P
R201	0113623	CF 2.2kΩ ±5% SRD1/6P [except ZS]	△R710	1110621	FR 100Ω ±5% RN1/4B	R945	0113639	CF 10kΩ ±5% SRD1/6P
R204	0113615	CF 1kΩ ±5% SRD1/6P	R711L,R	0119029	ME 4.7Ω ±10% RN1B	R946	0113639	CF 10kΩ ±5% SRD1/6P
			R714	1119446	ME 2.7kΩ ±10% RN1B	R947	0113639	CF 10kΩ ±5% SRD1/6P
			R715	0113659	CF 68kΩ ±5% SRD1/6P	R948	0113639	CF 10kΩ ±5% SRD1/6P
			R716	0113667	CF 150kΩ ±5% SRD1/6P	R949	0113663	CF 100kΩ ±5% SRD1/6P
			R717L,R	0113293	CF 330Ω ±5% SRD1/2P	R950	0113639	CF 10kΩ ±5% SRD1/6P
			R718	0113673	CF 270kΩ ±5% SRD1/6P	R951	0113647	CF 22kΩ ±5% SRD1/6P
						R952	0113647	CF 22kΩ ±5% SRD1/6P
						R953	0113665	CF 120kΩ ±5% SRD1/6P
						R954	0113615	CF 1kΩ ±5% SRD1/6P
						R955	0113633	CF 5.6kΩ ±5% SRD1/6P
						R956L,R	0113669	CF 180kΩ ±5% SRD1/6P
						R957L,R	0113657	CF 56kΩ ±5% SRD1/6P
						R958	0113647	CF 22kΩ ±5% SRD1/6P
						R959L,R	0113623	CF 2.2kΩ ±5% SRD1/6P
						R960	0113647	CF 22kΩ ±5% SRD1/6P
						R963	0113667	CF 150kΩ ±5% SRD1/6P
						R965	0113639	CF 10kΩ ±5% SRD1/6P
						R966	0113639	CF 10kΩ ±5% SRD1/6P

HRD-MD28

SYMBOL NO.	PART NO.	DESCRIPTION	SYMBOL NO.	PART NO.	DESCRIPTION	SYMBOL NO.	PART NO.	DESCRIPTION
CAPACITORS			C223	0252813	EL 3.3 μ F 50V	C559	0246449	CD 24pF \pm 5% 50V
C001	0244109	CD 4700pF \pm 10% 50V	C224	0252521	EL 10 μ F 16V	C561	0248672	CD 33pF \pm 5% 50V
C002	0244173	CD 0.022 μ F 50V [for ZS]	C225	0209731	CD 1000pF \pm 10% 50V	C562	0208664	CD 15pF \pm 5% 50V
C101	0275015	MF 0.047 μ F \pm 10% 50V	C226	0209737	CD 0.01 μ F \pm 10% 50V	C563	0244173	CD 0.022 μ F \pm 20% 50V
C102	0252802	EL 0.22 μ F 50V [for ZS]	C227	0209175	CD 0.047 μ F \pm 20% 50V	C564	0252325	EL 47 μ F 10V
C103	0208672	CD 33pF \pm 5% 50V	C228	0252813	EL 3.3 μ F 50V [for ZS]	C601L,R	0252811	EL 1 μ F 50V
C104	0252811	EL 1 μ F 50V [for ZS]	C301	0252813	EL 3.3 μ F 50V	C602L,R	0240214	CD 0.015 μ F \pm 10% 25V
C105	0244173	CD 0.022 μ F \pm 80% -20% 50V [for ZS]	C302	0252525	EL 47 μ F 16V	C603	0248678	CD 56pF \pm 5% 50V [for ZS]
C106	0208674	CD 39pF \pm 5% 50V [for ZS]	C303	0268446	PP 1000pF \pm 5% 100V	C604	0244101	CD 1000pF \pm 10% 50V [except ZS]
C107	0208674	CD 39pF \pm 5% 50V [for ZS]	C304	0252805	EL 0.47 μ F 50V	C651L,R	0252812	EL 2.2 μ F 50V
C108	0244173	CD 0.022 μ F 50V	C305	0252805	EL 0.47 μ F 50V	C652L,R	0240218	CD 0.033 μ F \pm 10% 25V
C109	0208672	CD 33pF \pm 5% 50V [for ZS]	C306	0275015	MF 0.047 μ F \pm 10% 50V	C653L,R	0252805	EL 0.47 μ F 50V
C110	0244171	CD 0.01 μ F \pm 80% -20% 50V [for ZS]	C307	0252811	EL 1 μ F 50V	C654L,R	0244171	CD 0.01 μ F \pm 80% -20% 50V
C111	0244171	CD 0.01 μ F \pm 80% -20% 50V [for ZS]	C308	0209736	CD 6800pF \pm 10% 50V [except US, CS]	C655L,R	0252801	EL 0.1 μ F 50V
C112	0244171	CD 0.01 μ F \pm 80% -20% 50V [for ZS]	C309	0209736	CD 6800pF \pm 10% 50V [except US, CS]	C656L,R	0240205	CD 2700pF \pm 10% 25V
C151	0275013	MF 0.022 μ F \pm 10% 50V	C310	0209733	CD 2200pF \pm 10% 50V	C657L,R	0240218	CD 0.033 μ F \pm 10% 25V
C152	0244173	CD 0.022 μ F \pm 80% -20% 50V [for VS, ES (France), BS]	C311	0209733	CD 2200pF \pm 10% 50V	C658L,R	0209726	CD 820pF \pm 10% 50V
C153	0246418	CD 8pF \pm 0.25pF 50V [for VS, ES (France), BS]	C312	0252813	EL 3.3 μ F 50V	C659L,R	0240209	CD 5600pF \pm 10% 25V
	0246412	CD 2pF \pm 0.25pF 50V [except VS, ES (France), BS]	C313	0252813	EL 3.3 μ F 50V	C660L,R	0208692	CD 220pF \pm 5% 50V
C154	0246456	CD 47pF \pm 5% 50V [for VS, ES (France), BS]	C314	0252522	EL 22 μ F 16V	C661L,R	0252813	EL 3.3 μ F 50V
C155	0268323	PP 510pF \pm 5% 100V	C315	0252813	EL 3.3 μ F 50V	C662L,R	0209731	CD 1000pF \pm 10% 50V
C156	0228321	ST 270pF \pm 5% 50V [for VS, ES (France), BS]	C316	0208526	CD 560pF \pm 5% 50V [for ZS]	C663L,R	0252522	EL 22 μ F 16V
C157	0246442	CD 12pF \pm 5% 50V	C317	0252531	EL 100 μ F 16V	C664L,R	0252813	EL 3.3 μ F 50V
C158	0246465	CD 110pF \pm 5% 50V [for VS, ES (France), BS]	C318	0244171	CD 0.01 μ F \pm 80% -20% 50V [for ZS]	C666	0244173	CD 0.022 μ F \pm 80% -20% 50V [for ZS]
C159	0252811	EL 1 μ F 50V [for BS, VS, ES(France)]	C319	0244171	CD 0.01 μ F \pm 80% -20% 50V [for ZS]	C701L,R	0252813	EL 3.3 μ F 50V
C160	0244173	CD 0.022 μ F 50V [for VS, ES(France), BS]	C320	0248684	CD 100pF \pm 5% 50V [except ZS]	C702L,R	0208692	CD 220pF \pm 5% 50V [except ZS]
C161	0244173	CD 0.022 μ F \pm 80% -20% 50V	C351	0252813	EL 3.3 μ F 50V	C703L,R	0208696	CD 330pF \pm 5% 50V [except ZS]
C201	0244173	CD 0.022 μ F \pm 80% -20% 50V	C401L,R	0209731	CD 1000pF \pm 10% 50V [for ZS]	C703L,R	0209731	CD 1000pF \pm 10% 50V [for ZS]
C202	0244173	CD 0.022 μ F \pm 80% -20% 50V	C402L,R	0252813	EL 3.3 μ F 50V	C704L,R	0252225	EL 47 μ F 6.3V [except ES (France)]
C203	0244173	CD 0.022 μ F \pm 80% -20% 50V	C403L,R	0208684	CD 100pF \pm 5% 50V	C704L,R	0252325	EL 47 μ F 10V [for ES (France)]
C204	0209737	CD 0.01 μ F \pm 10% 50V	C404L,R	0252325	EL 47 μ F 10V	C705L,R	0230612	CC 10pF \pm 5% 50V
C205	0209737	CD 0.01 μ F \pm 10% 50V	C405L,R	0240211	CD 8200pF \pm 10% 25V	C706L,R	0252625	EL 47 μ F 25V
C206	0209737	CD 0.01 μ F \pm 10% 50V	C406L,R	0240204	CD 2200pF \pm 10% 25V	C707	0252825	EL 47 μ F 50V
C207	0252813	EL 3.3 μ F 50V	C407L,R	0252813	EL 3.3 μ F 50V	C708	0252825	EL 47 μ F 50V
C209	0252525	EL 47 μ F 16V	C409	0244173	CD 0.022 μ F \pm 80% -20% 50V	C709	0252825	EL 47 μ F 50V
C210	0209737	CD 0.01 μ F \pm 10% 50V	C410	0244171	CD 0.01 μ F \pm 80% -20% 50V [for ZS]	C710L,R	0276011	MF 0.1 μ F \pm 10% 50V
C211	0209737	CD 0.01 μ F \pm 10% 50V	C411	0244173	CD 0.022 μ F \pm 80% -20% 50V	C711	0255011	EL 47 μ F 50V [except ES(France)]
C212	0252811	EL 1 μ F 50V	C421L,R	0208692	CD 220pF \pm 5% 50V [for ZS]		0252825	EL 47 μ F 50V [for ES(France)]
C213	0208684	CD 100pF \pm 5% 50V	C501	0209733	CD 2200pF \pm 10% 50V	C712	0255011	EL 47 μ F 50V [except ES(France)]
C214	0209737	CD 0.01 μ F \pm 10% 50V	C502	0252880	EL 4.7 μ F 50V	C713	0244171	CD 0.01 μ F \pm 80% -20% 50V [for ZS]
C215	0252813	EL 3.3 μ F 50V	C503	0252802	EL 0.22 μ F 50V [for VS, ES(France), BS]	C714L,R	0244173	CD 0.022 μ F \pm 80% -20% 50V [for ZS]
C217	0244173	CE 0.022 μ F \pm 80% -20% 50V	C504	0240222	CD 0.068 μ F \pm 10% 25V [for VS, ES(France), BS]	C715L,R	0244171	CD 0.01 μ F \pm 80% -20% 50V [for ZS]
C218	0252522	EL 22 μ F 16V	C505	0252811	EL 1 μ F 50V [for VS, ES(France), BS]	C716	0255011	EL 47 μ F 50V [except ES(France)]
C219	0209737	CD 0.01 μ F \pm 10% 50V	C506	0244173	CD 0.022 μ F \pm 80% -20% 50V	C716	0252825	EL 47 μ F 50V [for ES(France)]
C220	0252521	EL 10 μ F 16V	C551	0252813	EL 3.3 μ F 50V	C717	0244173	CD 0.022 μ F \pm 80% -20% 50V
C221	0209175	CD 0.047 μ F \pm 80% -20% 50V	C552	0252815	EL 4.7 μ F 50V	C718	0244173	CD 0.022 μ F \pm 80% -20% 50V [for ZS]
C222	0208676	CD 47pF \pm 5% 50V	C554	0252815	EL 4.7 μ F 50V	C720	0244163	CD 2200pF \pm 80% -20% 50V [for US, CS]
			C555	0244173	CD 0.022 μ F 50V			
			C556	0252242	EL 2200 μ F 6.3V			
			C558	0246499	CD 24pF \pm 5% 50V			

SYMBOL NO.	PART NO.	DESCRIPTION
R967L,R	0113647	CF 22kΩ ±5% SRD1/6P
R968	0113639	CF 10kΩ ±5% SRD1/6P
R969	0113631	CF 4.7kΩ ±5% SRD1/6P
R981	0113631	CF 4.7kΩ ±5% SRD1/6P
R982	0113615	CF 1kΩ ±5% SRD1/6P
R983	0113675	CF 330kΩ ±5% SRD1/6P
R984	0113615	CF 1kΩ ±5% SRD1/6P
R985	0113583	CF 47Ω ±5% SRD1/6P
R986	0113631	CF 4.7kΩ ±5% SRD1/6P
R987	0113631	CF 4.7kΩ ±5% SRD1/6P
R988	0113665	CF 120kΩ ±5% SRD1/6P
R989	0113639	CF 10kΩ ±5% SRD1/6P
R990	0113617	CF 1.2kΩ ±5% SRD1/6P
R991	0113649	CF 27kΩ ±5% SRD1/6P
R992	0113567	CF 10Ω ±5% SRD1/6P
R993	0113591	CF 100Ω ±5% SRD1/6P [for ES, BS]
R994	0113295	CF 470Ω ±5% SRD1/2P
R996	0113291	CF 220Ω ±5% SRD1/2P

ICS & TRANSISTORS

IC101	2300601	LA1186N [except ZS]
IC201	2389231	LA1260
IC231	2368431	AN278 [for ZS]
IC301	2300561	LA3361
IC401	2300831	μPC4558C
IC651L,R	2300841	BA3812L
IC701	2301161	STK4142 [except BS, US]
IC701	2301011	STK4122II [for BS, US]
IC901	2301052	BA3416BL
IC902	2300831	μPC4558C
IC903	2301201	HA12086
IC904	2300831	μPC4558C
IC981	2387051	LB1403
Q131	2328286	2SC458LG (D) [for ZS]
Q132	2328803	2SK104 (H) [for ZS]
Q201	0573487	2SC460C [except ZS]
Q801	2317824	2SD880 (O.Y)
Q802	2328273	2SB605LA
Q901L,R	2329453	2SC945PA
Q902	2329453	2SC945PA
Q903L,R	2329453	2SC945PA
Q904	2329453	2SC945PA
Q905L,R	2329453	2SC945PA
Q906L,R	2329453	2SC945PA
Q907L,R	2329453	2SC945PA
Q908L,R	2329453	2SC945PA
Q910	2329453	2SC945PA
Q911	2329453	SSC945PA
Q912	2329453	2SC945PA
Q913	2329453	2SC945PA
Q914	2329183	2SA1015 (GR)
Q915L,R	2329952	2SD655E
Q981	2329453	2SC945PA
Q991	2317782	2SC2235 (Y)

DIODES

D101	2337601	1S2473 [except ZS]
D131	2337601	1S2473 [for ZS]
D132	2337601	1S2473 [for ZS]
D133	2337931	1K60R [for ZS]
D134	2337931	1K60R [for ZS]
D151	2337601	1S2473
D152	2337601	1S2473
D301	2339102	SLP-160C
D331	2338831	SLP-155B
D701	2337601	1S2473
D702	2339001	DS135D
D801	2337461	S4VB20
D802	2339001	DS135
D803	2339001	DS135

SYMBOL NO.	PART NO.	DESCRIPTION
D901	2337601	1S2473
D902	2337601	1S2473
D903	2337601	1S2473
D904	2337601	1S2473
D905	2337601	1S2473
D906	2337601	1S2473
D907	2337601	1S2473
D908	2337601	1S2473
D909	2337601	1S2473
D910	2337601	1S2473
D911	2337601	1S2473
ZD301	2339664	HZ6B-1 [for ZS]
ZD302	2339664	HZ6B-1 [for ZS]
ZD801	2339613	HZ-15-3-FA
ZD802	2339613	HZ-15-3-FA
ZD901	2337613	HZ3A-3
LED981	2339102	SLP-160C
LED982	2398401	SLR-54DC5
LED983	2398401	SLR-54DC5
LED984	2398401	SLR-54DC5
LED985	2398401	SLR-54DC5
LED986	2339102	SLP-160C
LED987	2339102	SLP-160C

VARIABLE RESISTORS

RT131	0150959	20kΩ -(B) [for ZS]
RT132	0150961	100kΩ -(B) [for ZS]
RT301	0150958	10kΩ -(B)
RT901L,R	0150961	100kΩ -(B)
RT902	0158953	2kΩ -(B)
RV901L,R	0166838	10kΩ -(B)
RV601	0166837	250KΩ
RV602L,R	0158781	100kΩ -(B)
RV652L,R	0166831	100kΩ -(B)
RV653L,R	0166831	100kΩ -(B)
RV654L,R	0166831	100kΩ -(B)

COILS

L101	2135262	FM RF coil [except ZS, ES, BS]
L101	2135376	FM RF coil [for ES, BS]
L102	2135253	FM osc coil [for US]
L102	2135493	FM osc coil [for ES, BS]
L102	2135248	FM osc coil [for EW, SA, KS]
L151	2227354	Choke coil 2.2μH [for ES, BS]
L202	2227889	High freq coil
L901L,R	2227991	Choke coil
L991	2136823	Bias OSC coil (85kHz)
T101	2154724	FM IF transformer [except ZS]
T151	2137371	AM ant coil (MW)
T152	2136496	AM osc coil (MW)
T153	2137372	AM ant coil (LW) [for ES, BS]
T154	2136497	AM osc coil [for ES, BS]
T201	2154729	FM discrete coil

MISCELLANEOUS

CP101	2137191	FM band pass filter [except ZS]
CP131	2137301	FM band pass filter [for ZS]
CP301	2136313	Low pass filter [for ZS]

SYMBOL NO.	PART NO.	DESCRIPTION
CF201	2135002	Ceramic filter [for ZS]
CF 202	2135002	Ceramic filter [for ZS]
CF203	2135002	Ceramic filter
CF205	2154761	Ceramic filter
CT101	0282411	Variable capacitor [for US, KS, SA, EW]
CT102	0282411	Variable capacitor [for US, KS, SA, EW]
CT151	0282411	Variable capacitor [for US, KS, SA, EW]
CT152	0282411	Variable capacitor [for US, KS, SA, EW]
CV101	0282411	Variable capacitor [for US, KS, SA, EW]
CV102	0282411	Variable capacitor [for US, KS, SA, EW]
CV151	0282411	Variable capacitor [for US, KS, SA, EW]
CV152	0282411	Variable capacitor [for US, KS, SA, EW]
CT101	0282113	Variable capacitor [for BS, ES]
CT102	0282113	Variable capacitor [for BS, ES]
CV101	0282113	Variable capacitor [for BS, ES]
CV102	0282113	Variable capacitor [for BS, ES]
CV151	0282113	Variable capacitor [for BS, ES]
CV152	0282113	Variable capacitor [for BS, ES]
CT151	0283557	Plastic film adjustable Capacitor [for ES, BS]
CT152	"	" " "
CT153	"	" " "
CT154	"	" " "
CV151	0282382	Capacitor variable [for ZS]
CV152	0282382	Capacitor variable [for ZS]
RV131	0282382	Capacitor variable [for ZS]
S001	2600152	Power switch
S002	2618053	Voltabe selector switch
S101	2600452	2key push switch [for ES, BS]
S201	2600452	2key push switch [for ES, BS]
S201	2600453	1key push switch [except ES, BS]
S601	2600451	4key push switch TUNER
S602	2600451	4key push switch CD
S603	2600451	4key push switch PHONO
S604	2600451	4key push switch TAPE
S605	2600283	1key push switch LOUDNESS
S901	2628982	Slide switch R/P
S902	2600287	3 key push switch TAPE SELECTOR
S903	2600283	1key push switch DOLBY
S991	2629381	Slide switch RIF SW [for ES, BS]
J701	2689551	4P push terminal
J702	2678448	Headphone jack
J981	2678447	Mic jack
J401L,R	2677874	4P Pin jack
J402L,R	2677874	4P Pin jack

SYMBOL NO.	PART NO.	DESCRIPTION
F131	2425561	Tuner pack [for ZS]
△F001	2727191	Fuse (T1A-250V) [except BS, US]
△F001	2727895	Fuse 1A-125V [for US]
△F001	2727730	Fuse T630mA-250V [for BS]
△F801	2727193	Fuse (T2A-250V) [except BS, US]
△F801	2727893	Fuse 2A-125V [for US]
△F801	2727745	Fuse (T2A) [for BS]
△PT001	2249612	Power transformer [for SA]
△PT001	2249622	Power trans 240V [for BS]
△PT001	2249613	Power transformer [for ZS, ES, KS]
△PT001	2249621	Power trans 120V [for US]
△PT001	2249614	Power transformer [for EW]
LC901L,R	2228103	Dolby filter
LC902L,R	2136791	Bias trap coil
	2527121	TD P.W.B assy [for US]
	2527122	TD P.W.B assy [for BS,ES]
	2527123	TD P.W.B assy [for KS, SA, EW]
	2527124	TD P.W.B assy [for ZS]
	2527131	GE P.W.B assy [for US]
	2527133	GE P.W.B assy [for BS]
	2527134	GE P.W.B assy [for KS]
	2527135	GE P.W.B assy [for ES]
	2527136	GE P.W.B assy [for ZS]
	2527137	GE P.W.B assy [for SA]
	2527138	GE P.W.B assy [for EW]

CABINET CHASSIS ASSEMBLY

1	4469054	Top case
2	3806441	Cassette door (1)
3	3806442	Cassette door (2)
4	3307213	Power button
5	3802051	Power switch rod
6	3307242	GE knob
7	3307201	Push button
8	3307232	Slide knob
9	3307191	Push button
10	3806451	Function button
11	3806452	Function button
12	3806453	Function button
13	3806454	Function button
14	3307281	Push button
15	3307262	Volume knob
16	3307252	REC knob
17	3802002	REC holder
18	4477171	Rear plate [for US]
	4477173	Rear plate [for BS]
	4477174	Rear plat [for KS]
	4477175	Rear plate [for ES]
	4477176	Rear plate [for ZS]
	4477177	Rear plate [for SA]
	4477178	Rear plate [for EW]
19	3927411	Foot
20	4415974	Washier (3.3x8)
21	3161461	Bottom board
22	3802071	Pointer

SYMBOL NO.	PART NO.	DESCRIPTION
23	3346235	Pulley (150)
24	3340322	Spring (M)
25	3368853	REC spring
26	2589322	Mechanism assy (TN-21SW-958)
27	4043751	Front panel assy [for US]
	4043752	Front panel assy [for BK, ES]
	4043753	Front panel assy [for KS, SA, EW]
	4043754	Front panel assy [for ZS]
△ 28	2702713	Power cord [for US]
△	2749582	Power cord [for BS]
△	2749622	Power cord [for SA]
△	2748752	Power cord [for ES, ZS, KS]
△	2706584	Power supply cord [for EW]
29	4691911	Counter belt
30	4468981	REC lever (B)
31	3368841	REC wire
32	4475821	Eject spring
33	4475831	Eject spring
34	2588921	Counter
35	3805191	Operation button
36	3307317	Operation button
37	3805197	Operation button
38	3805198	Operation button
39	3805199	Operation button
40	3805190	Operation button
41	3806471	Operation button
42	4418841	Clip antenna [for US]
43	4930712	Cord cover [for US]
44	2677911	FM antenna socket [except ZS, US]
45	2658391	Din ant socket [for ZS]
△ 46	3913006	Bushing [except EW]
△	0043793	Bushing [for EW]
△ 47	2618053	Voltage selector switch [for EW]
48	4041711	Slide piece assy
49	0681276	Washer (3.3x10)
50	4408861	Washer
51	4575661	Earth screw
52	4575453	DT bind (with washer)
53	4567432	DT bind head screw (3x8)
54	8691410	BT bind head screw (3x10)
55	8751413	Tapping pan head screw (3,1 x 13)
56	4567412	DT bind head screw (3x8)
57	4575444	4x12 DT bind screw (with Washer)
58	4567411	DT bind head screw (3x6)
59	0741306	Bind screw (2.6x6)
60	4584792	DT bind head screw (2x5)
61	4567432	DT bind head screw (3x8) [for ZS]
62	4567443	DT bind head screw (4x10)
63	8691412	BT bind head screws (3x12)
64	4567415	DT bind head screw (3x14)
65	3931571	Holder ANTENNA
66	3307271	TUNING ASSY
67	3950381	DAMPER ASSY
68	3929692	ROLLER
69	3935291	ROLLER

SYMBOL NO.	PART NO.	DESCRIPTION
70	4585811	Screw
for ACCESSORIES		
	2757527	FM antenna [for SA]
	2667922	SIEMENS PLUG [for EW]
	2758411	AM loop antenna
	2749091	US pin cord [for ZS]

SY	PARTS NO.	PART NO.	DESCRIPTION
	CABINET CHASSIS ASSEMBLY		
R	1	4469054	Top case
R	2	3806441	Cassette door (1)
R	3	3806442	Cassette door (2)
R	4	3307213	Power button
R	5	3802051	Power switch rod
R	6	3307242	GE knob
R	7	3307201	Push button
R	8	3307232	Slide knob
R	9	3307191	Push knob
R	10	3806451	Function button
R	11	3806452	Function button
R	12	3806453	Function button
R	13	3806454	Function button
R	14	3307262	Volume knob
R	15	4041711	Slide piece assy
R	16	3307294	Pre-set knob [except BS, ES(France)]
R		3307295	Pre-set knob [for BS, ES(France)]
R	17	3307303	Tuning button
R	18	3307252	REC knob
R	19	3802002	REC holder
R	20	4477201	Rear plate [for US]
R		4477202	Rear plate [for CS]
R		4477203	Rear plate [for BS]
R		4477204	Rear plate [for KS]
R		4477205	Rear plate [for VS]
R		4477206	Rear plate [for ZS]
R		4477207	Rear plate [for SA]
R		4477208	Rear plate [for EW]
R		4477209	Rear plate [for ES(France)]
R	21	3950381	Damper assy
R	22	4043781	Front panel assy [except VS, ES(France), BS]
R		4043782	Front panel assy [for VS, ES(France), BS]
R	23	3927411	Foot
R	24	4415974	Washer (3.3x8)
R	25	3368853	REC spring
R	26	3161461	Bottom board
R	27	0681276	Washer (3.3x10)
R	28	3931571	Holder ANTENNA
R	29	4584792	DT bind head screw (2x5)
R	30	4691911	Counter belt
R	31	4468981	REC lever (B)
R	32	3368841	REC wire
R	33	4475821	Eject spring
R	34	4475831	Eject spring
R	35	2588921	Counter
R	36	3805191	Operation button
R	37	3307317	Operation button
R	38	3805197	Operation button
R	39	3805198	Operation button
R	40	3805199	Operation button
R	41	3805190	Operation button
R	42	3806471	Operation button
R	△ 43	2702713	Power supply cord [for CS, US]
R	△	2749582	Power supply cord [for BS]
R	△	2749622	Power supply cord [for SA]
R	△	2748752	Power supply cord [for ZS, VS, KS]

PARTS NO.	PART NO.	DESCRIPTION
△	2707709	Power supply cord [for ES(France)]
△	2706584	Power supply cord [for EW]
44	4418841	Clip antenna [for CS, US]
45	4930712	Cord cover [for CS, US]
46	2677911	FM antenna socket [except ZS, CS, US]
47	2658391	Din ant socket [for ZS]
△ 48	3913006	Bushing [except EW]
△	0043793	Bushing [for EW]
49	4575661	Earth screw
50	4408861	Washer
51	2589322	Mechanism assy (TN-21SW-985)
52	8691412	BT bind head screw (3x12)
53	4575453	4x12 DT bind screw (with washer)
54	4567432	DT bind head screw (3x8)
55	8691410	BT bind head screw (3x10)
56	4567411	DT bind head screw (3x6)
57	8751413	Tapping pan head screw (3.1x13)
58	4567443	DT bind head screw (4x10)
59	4575444	4x12 DT bind screw (with washer)
60	4567415	DT bind head screw (3x4)
for ACCESSORIE		
	2757527	FM antenna [for SA]
	2667922	Siemens plug [for HL, EW]
	2758411	AM loop antenna

SYMBOL NO.	PART NO.	DESCRIPTION	SYMBOL NO.	PART NO.	DESCRIPTION	SYMBOL NO.	PART NO.	DESCRIPTION
R557	0113639	CF 10kΩ ±5% SRD1/6P	R928L,R	0113651	CF 33kΩ ±5% SRD1/6P	IC904	2300831	μPC4558C
R558	0113623	CF 2.2kΩ ±5% SRD1/6P	R929	0113631	CF 4.7kΩ ±5% SRD1/6P	IC981	2387051	LB1403
R559	0113287	CF 100Ω ±5% SRD1/6P	R930	0113657	CF 56kΩ ±5% SRD1/6P	Q101	2328286	2SC45BLG (D) [for ZS]
R561	0113667	CF 150kΩ ±5% SRD1/6P	R931L,R	0113659	CF 68kΩ ±5% SRD1/6P	Q102	2328803	2SK104H [for ZS]
R562	0113615	CF 1kΩ ±5% SRD1/6P	R932L,R	0113633	CF 5.6kΩ ±5% SRD1/6P	Q151	2328286	2SC45BLG (D) [for VS, ES(France), BS]
R563	0129569	CF 220Ω ±5% SRD1/4P	R933L,R	0113641	CF 12kΩ ±5% SRD1/6P	Q152	2328286	2SC45BLG (D) [for VS, ES(France), BS]
R564	0129573	CF 330Ω ±5% SRD1/4P	R934L,R	0113631	CF 4.7kΩ ±5% SRD1/6P	Q201	2328286	2SC458LG (D)
R565	0113639	CF 10kΩ ±5% SRD1/6P [for EW]	R935	0113663	CF 100kΩ ±5% SRD1/6P	Q301	2328286	2SC45BLG (D)
R601L,R	0113615	CF 1kΩ ±5% SRD1/6P	R936L,R	0113639	CF 10kΩ ±5% SRD1/6P	Q302	2328286	2SC45BLG (D)
R602L,R	0113663	CF 100kΩ ±5% SRD1/6P	R937L,R	0113619	CF 1.5kΩ ±5% SRD1/6P	Q303	2329183	2SA1015 GR
R603L,R	0113631	CF 4.7kΩ ±5% SRD1/6P	R938L,R	0113583	CF 47Ω ±5% SRD1/6P	Q304	2328286	2SC458LG (D)
R604L,R	0113643	CF 15kΩ ±5% SRD1/6P	R940L,R	0113625	CF 2.7kΩ ±5% SRD1/6P	Q351	2328286	2SC458LG (D)
R651L,R	0113627	CF 3.3kΩ ±5% SRD1/6P	R941L,R	0113631	CF 4.7kΩ ±5% SRD1/6P	Q352	2328286	2SC458LG (D)
R652L,R	0113627	CF 3.3kΩ ±5% SRD1/6P	R942L,R	0113619	CF 3.3kΩ ±5% SRD1/6P	Q501	2328286	2SC458LG (D)
R701L,R	0113623	CF 2.2kΩ ±5% SRD1/6P [for ZS]	R943	0113639	CF 10kΩ ±5% SRD1/6P	Q502	2328286	2SC458LG (D)
R701L,R	0113615	CF 1kΩ ±5% SRD1/6P [except ZS]	R944L,R	0113627	CF 3.3kΩ ±5% SRD1/6P	Q503	2328286	2SC458LG (D) [for VS, ES(France), BS]
R702L,R	0113663	CF 100kΩ ±5% SRD1/6P	R945	0113639	CF 10kΩ ±5% SRD1/6P	Q504	2328286	2SC458LG (D) [for VS, ES(France), BS]
R703L,R	0113607	CF 470Ω ±5% SRD1/6P	R946	0113639	CF 10kΩ ±5% SRD1/6P	Q505	2329183	2SA1015 (GR)
R704L,R	0113663	CF 100kΩ ±5% SRD1/6P	R947	0113639	CF 10kΩ ±5% SRD1/6P	Q506	2328286	2SC458LG (D)
R705L,R	0129611	CF 2.7kΩ ±5% SRD1/4P	R948	0113639	CF 10kΩ ±5% SRD1/6P	Q507	2329183	2SA1015 (GR)
R706L,R	0129611	CF 2.7kΩ ±5% SRD1/4P	R949	0113663	CF 100kΩ ±5% SRD1/6P	Q508	2329183	2SA1015 (GR) [for EW]
R707	0129601	CF 1kΩ ±5% SRD1/4P	R950	0113639	CF 10kΩ ±5% SRD1/6P	Q509	2328286	2SC458LG (D) [for EW]
R708	1110621	FR 100Ω ±5% RN1/4B	R951	0113647	CF 22kΩ ±5% SRD1/6P	Q510	2329183	2SA1015 (GR)
R709	0129617	CF 4.7kΩ ±5% SRD1/4P	R952	0113647	CF 22kΩ ±5% SRD1/6P	Q511	2329183	2SA1015 (GR)
R710	1110621	FR 100Ω ±5% RN1/4B	R953	0113665	CF 120kΩ ±5% SRD1/6P	Q512	2329183	2SA1015 (GR) [for VS, ES(France), BS]
R711L,R	1119029	FR 4.7Ω ±10% RN1B	R954	0113615	CF 1kΩ ±5% SRD1/6P	Q513	2329183	2SA1015 (GR) [for VS, ES(France), BS]
R714	1119446	M0 2.7kΩ ±10% RS1B	R955	0113633	CF 5.6kΩ ±5% SRD1/6P	Q551	2329183	2SA1015 (GR)
R715	0113659	CF 68kΩ ±5% SRD1/6P	R956L,R	0113669	CF 180kΩ ±5% SRD1/6P	Q561	0573486	2SC460 (B)
R716	0113667	CF 150kΩ ±5% SRD1/6P	R957L,R	0113657	CF 56kΩ ±5% SRD1/6P	Q801	2317824	2SD880 (Y.O)
R717L,R	0113293	CF 330Ω ±5% SRD1/2P	R958	0113647	CF 22kΩ ±5% SRD1/6P	Q802	2328273	2SB605LA
R718	0113673	CF 270kΩ ±5% SRD1/6P	R959L,R	0113623	CF 2.2kΩ ±5% SRD1/6P	Q901L,R	2329453	2SC945PA
R719	0113639	CF 10kΩ ±5% SRD1/6P	R960	0113647	CF 22kΩ ±5% SRD1/6P	Q902	2329453	2SC945PA
R801	0129613	CF 3.3kΩ ±5% SRD1/4P	R962	0113667	CF 150kΩ ±5% SRD1/6P	Q903L,R	2329453	2SC945PA
R802	1119155	MF 22Ω ±10% RN2B	R963	0113667	CF 150kΩ ±5% SRD1/6P	Q904	2329453	2SC945PA
R803	0129615	CF 3.9kΩ ±5% SRD1/4P	R964	0113639	CF 10kΩ ±5% SRD1/6P	Q905L,R	2329453	2SC945PA
R804	1110625	FR 220Ω ±5% SRD1/4P	R965	0113639	CF 10kΩ ±5% SRD1/6P	Q906L,R	2329453	2SC945PA
R806	0129607	CF 1.8kΩ ±5% SRD1/4P	R966	0113639	CF 10kΩ ±5% SRD1/6P	Q907L,R	2329453	2SC945PA
R811	1110601	FR 10Ω ±5% RN1/4B	R967L,R	0113647	CF 22kΩ ±5% SRD1/6P	Q908L,R	2329453	2SC945PA
R812	1110601	FR 10Ω ±5% RN1/4B	R968	0113639	CF 10kΩ ±5% SRD1/6P	Q909L,R	2329453	2SC945PA
R813	1110601	FR 10Ω ±5% RN1/4B	R969	0113631	CF 4.7kΩ ±5% SRD1/6P	Q910	2329453	2SC945PA
R901L,R	0113579	CF 33Ω ±5% SRD1/6P	R981	0113631	CF 4.7kΩ ±5% SRD1/6P	Q911	2329453	2SC945PA
R902L,R	0113663	CF 100kΩ ±5% SRD1/6P	R982	0113615	CF 1kΩ ±5% SRD1/6P	Q912	2329453	2SC945PA
R903L,R	0113629	CF 3.9kΩ ±5% SRD1/6P	R983	0113675	CF 330k ±5% SRD1/6P	Q913	2329453	2SC945PA
R904	0113625	CF 2.7kΩ ±5% SRD1/6P	R984	0113615	CF 1kΩ ±5% SRD1/6P	Q914	2329183	2SA1015 (GR)
R905L,R	0113623	CF 2.2kΩ ±5% SRD1/6P	R985	0113583	CF 47Ω ±5% SRD1/6P	Q915L,R	2329952	2SD655 (E) [except ES(France)]
R906L,R	0113627	CF 3.3kΩ ±5% SRD1/6P	R986	0113631	CF 4.7kΩ ±5% SRD1/6P	Q915L,R	2329951	2SD655 (D) [for ES(France)]
R907	0113651	CF 33kΩ ±5% SRD1/6P	R987	0113631	CF 4.7kΩ ±5% SRD1/6P	Q981	2329453	2SC945PA
R909L,R	0113637	CF 8.2kΩ ±5% SRD1/6P	R988	0113665	CF 120kΩ ±5% SRD1/6P	Q991	2317782	2SC2235 (Y)
R910L	0113641	CF 12kΩ ±5% SRD1/6P	R989	0113639	CF 10kΩ ±5% SRD1/6P	DIODES		
R910R	0113639	CF 10kΩ ±5% SRD1/6P	R990	0113617	CF 1.2kΩ ±5% SRD1/6P	D101	2337601	1S2473
R911	0113639	CF 10kΩ ±5% SRD1/6P	R991	0113649	CF 27kΩ ±5% SRD1/6P	D102	2337601	1S2473
R912	0113651	CF 33kΩ ±5% SRD1/6P	R992	0113567	CF 10Ω ±5% SRD1/6P	D103	2337931	1K60R [for ZS]
R913L,R	0113639	CF 10kΩ ±5% SRD1/6P	R993	0113591	CF 100Ω ±5% SRD1/6P [for VS, ES(France), BS]	D104	2337931	1K60R [for ZS]
R914L,R	0113639	CF 10kΩ ±5% SRD1/6P	R994	0113295	CF 470Ω ±5% SRD1/2P	D151	2337601	1S2473
R915	0113651	CF 33kΩ ±5% SRD1/6P	R995	0113291	CF 220Ω ±5% SRD1/2P	D152	2337601	1S2473
R916	0113639	CF 10kΩ ±5% SRD1/6P	R996	0113228	CF 82Ω ±5% SRD1/2P	D153	2397321	KV1260
R917L,R	0113627	CF 3.3kΩ ±5% SRD1/6P	ICs & TRANSISTORS			D154	2397321	KV1260 [for VS, ES(France), BS]
R918L,R	0113639	CF 10kΩ ±5% SRD1/6P	IC201	2368431	AN278			
R919L,R	0113663	CF 100kΩ ±5% SRD1/6P	IC202	2300412	LA12655			
R920	0113647	CF 22kΩ ±5% SRD1/6P	IC301	2300561	LA3361			
R921	0113647	CF 22kΩ ±5% SRD1/6P	IC401	2300831	μPC4558C			
R922	0113639	CF 10kΩ ±5% SRD1/6P	IC501	2300861	μPD1713AG-015			
R923L,R	0113633	CF 5.6kΩ ±5% SRD1/6P	IC502	2387611	BA6251			
R924	0113647	CF 22kΩ ±5% SRD1/6P	IC651L,R	2300841	BA3812L			
R925	0113647	CF 22kΩ ±5% SRD1/6P	IC701	2301161	STK4142II			
R926	0113291	CF 220Ω ±5% SRD1/2P	IC901	2301052	BA3416BL			
R927L,R	0113639	CF 10kΩ ±5% SRD1/6P	IC902	2300831	μPC4558C			
			IC903	2301201	HA12086			

SYMBOL NO.	PART NO.	DESCRIPTION	SYMBOL NO.	PART NO.	DESCRIPTION	SYMBOL NO.	PART NO.	DESCRIPTION
D155	2337601	1S2473 [for VS, ES(France), BS]	RV653L,R	0166831	100k Ω -(B)	J701	2689551	4P Push terminal
D156	2337601	1S2473 [for VS, ES(France), BS]	RV654L,R	0166831	100k Ω -(B)	J702	2678448	Headphone jack
D157	2337601	1S2473 [for VS, ES(France), BS]	RV655L,R	0166831	100k Ω -(B)	J981	2678447	Mic jack
D158	2337601	1S2473 [for VS, ES(France), BS]	RV901L,R	0166838	10k Ω -(B)		2780082	LCD
D159	2337601	1S2473 [for VS, ES(France), BS]	RT301	0150958	10k Ω -(B) [except ES(France)]		3802041	LED Holder
D301	2337601	1S2473	RT301	0199331	10k Ω -(B) [for ES(France)]	PT001 Δ	2249617	Power transformer 120V [for CS]
D501	2337601	1S2473	RT901L,R	0150961	100k Ω -(B) [except ES(France)]	PT001 Δ	2249612	Power transformer 240V [for SA, BS]
D502	2337601	1S2473	RT901L,R	0199334	100k Ω [for ES(France)]	PT001 Δ	2249613	Power transformer 220V [for VS, ZS, KS, ES(France)]
D503	2337601	1S2473	RT902	0158953	2k Ω -(B) [except ES(France)]	PT001 Δ	2249611	Power transformer 120V [for US]
D504	2337601	1S2473	RT902	0199333	2k Ω [for ES(France)]	PT001 Δ	2249614	Power transformer W [for EW]
D505	2337601	1S2473	COILS			F101	2425461	Tuner pack [except ZS]
D506	2337601	1S2473	L151	2127273	AM ant coil (MW)	F101	2425561	Tuner pack [for ZS]
D507	2337601	1S2473	L152	2137374	AM ant coil (LW) [for VS, ES(France), BS]	F001 Δ	2727191	Fuse T1A 250V [except BS, CS, US]
D508	2337601	1S2473	L153	2136493	AM osc coil (MW)	F001 Δ	2727964	Fuse 2.5A 125V [for CS, US]
D509	2337601	1S2473	L154	2136494	LW osc coil (MW) [for VS, ES(France), BS]	F001 Δ	2727742	Fuse T1A 250V [for BS]
D510	2337601	1S2472 [except US, CS]	L991	2136823	Bias osc coil	F801 Δ	2727193	Fuse T2A 250V [except BS, CS, US]
D511	2337601	1S2473	L901L,R	2227991	Choke coil	F801 Δ	2727745	Fuse T2A 250V [for BS]
D512	2337601	1S2473	T201	2154493	AM IF transformer	F801 Δ	2727893	Fuse 2A 125V [for CS, US]
D513	2337601	1S2473 [except SA, CS, US]	T202	2137033	FM discriminator coil	MF201	2135002	Ceramic filter
D514	2337601	1S2473	MISCELLANEOUS			MF202	2135002	Ceramic filter [for ZS, VS]
D515	2337601	1S2473	CP101	2137301	FM band pass filter [for ZS]	MF203	2135002	Ceramic filter
D516	2337601	1S2473	C557	0259891	Super capacitor 0.022F	MF205	2154762	Ceramic filter
D551	2337151	1S2076A	CP301	2136313	Lowpass filter [for ZS]	LC901L,R	2228103	Dolby filter
D552	2337601	1S2473	X551	2789281	Crystal oscillator	LC902L,R	2136791	Bias trap coil
D553	2337601	1S2473	S001 Δ	2600152	Power switch		2527091	TD P.W.B assy [for US, CS]
D701	2337601	1S2473	S002 Δ	2618053	Voltage selector switch [for EW]		2527093	TD P.W.B assy [for BS]
D702	2339001	DS135D	S501	2639971	Tact switch FM		2527094	TD P.W.B assy [for KS]
D801	2337461	S4VB20	S502	2639971	Tact switch AUTO		2527095	TD P.W.B assy [for VS]
D802	2339001	DS135D	S503	2639682	Tact switch P4		2527096	TD P.W.B assy [for ZS]
D803	2339001	DS135D	S504	2639682	Tact switch P3		2527097	TD P.W.B assy [for SA]
D901	2337601	1S2473	S505	2639682	Tact switch P2		2527098	TD P.W.B assy [for EW]
D902	2337601	1S2473	S506	2639682	Tact switch P1		2527099	TD P.W.B assy [for ES(France)]
D903	2337601	1S2473	S507	2639971	Tact switch MW		2527101	GE-PA P.W.B assy [for US]
D904	2337601	1S2473	S508	2639682	Tact switch MEMORY		2527102	GE-PA P.W.B assy [for CS]
D905	2337601	1S2473	S509	2639682	Tact switch P5		2527103	GE-PA P.W.B assy [for BS]
D906	2337601	1S2473	S510	2639971	Tact switch DOWN		2527104	GE-PA P.W.B assy [for KS]
D907	2337601	1S2473	S511	2639971	Tact switch UP		2527105	GE-PA P.W.B assy [for VS]
D908	2337601	1S2473	S512	2639971	Tact switch LW [for VS, ES(France), BS]		2527106	GE-PA P.W.B assy [for ZS]
D909	2337601	1S2473	S513	2629381	Slide switch [for EW]		2527107	GE-PA P.W.B assy [for SA]
D910	2337601	1S2473	S514	2639971	Tact switch +10 [for BS, ES(France)]		2527108	GE-PA P.W.B assy [for EW]
D911	2337601	1S2473	S601	2600451	4 key push switch TUNER		2527109	GE-PA P.W.B assy [for ES(France)]
ZD551	2339657	HZ5C-1	S602	2600451	4 key push switch CD			
ZD552	2339664	HZ6B-1	S603	2600451	4 key push switch PHONO			
ZD553	2337292	HZ-9B	S604	2600451	4 key push switch TAPE			
ZD801	2339613	HZ-15-3-FA	S605	2600283	1 key push switch LOUDNESS SW			
ZD802	2339613	HZ-15-3-FA	S901	2628982	Slide switch R/P			
ZD901	2337613	HZ3A-3	S902	2600286	3 key push switch			
LED551	2398451	BACK LIGHTING	S903	2600283	1 key push switch DOLBY			
LED552	2378451	BACK LIGHTING	S991	2629381	Slide switch RIF SW [for VS, ES(France), BS]			
LED553	2398451	BACK LIGHTING	S903	2600283	1 key push switch DOLBY			
LED554	2378451	BACK LIGHTING	S991	2629381	Slide switch RIF SW [for VS, ES(France), BS]			
LED555	2398452	LN0513CP8	J401L,R	2677874	Pin jack 4P			
LED981	2339102	SLP-160C	J402L,R	2677874	Pin jack 4P			
LED982	2398401	SLR-54DCS	VARIABLE RESISTORS					
LED983	2398401	SLR-54DCS	RV601	0166837	250k Ω			
LED984	2398401	SLR-54DCS	RV602L,R	0158781	100k Ω -(B)			
LED985	2398401	SLR-54DCS	RV651L,R	0166831	100k Ω -(B)			
LED986	2339102	SLP-160C	RV652L,R	0166831	100k Ω -(B)			

REPLACEMENT PARTS LIST

CASSETTE CHASSIS (TN-21SW-985)

PARTS NO.	PART NO.	DESCRIPTION	PARTS NO.	PART NO.	DESCRIPTION	PARTS NO.	PART NO.	DESCRIPTION
1	4818991	MAIN base assy	36	4850693	Pinch roller arm spring	74	4819191	Tapping screw (2x6)
2	4818992	Switch plate	37	4833455	Pause bracket	75	4819611	Screw (2x6)
3	4839371	Push button actuator assy	38	4831610	Metal guide	76	4839383	Anti vibration felt mat
4	4823651	REC button lever	39	4839373	RF pulley arm assy	77	4819060	Screw (2x7)
5	4823661	PLAY button lever	40	4820225	RF pulley arm spring	78	4819600	Azimuth screw
6	4823671	RWD button lever	41	4835913	RF arm collar screw	79	4819202	Camera screw (2x4.5)
7	4823681	FF button lever	42	4820227	Belt	80	4832471	Camera screw (M2x2.5)
8	4823691	STOP button lever	43	4839374	Flywheel assy	81	4832472	Camera screw (M1.7x4.5)
9	4823701	PAUSE button lever	44	4839375	Flywheel assy	82	4850697	Camera screw (1.7x3)
10	4818990	RWD lever	46	4839377	TAKE UP gear plate assy	83	4850698	Washer (1.55)
11	4833451	PAUSE lever	47	4839378	TAKE UP roller gear	84	4819078	Washer (1.55)
12	4819132	PAUSE lever spring	48	4819020	TG plate spring	85	4832432	Washer (2.05)
13	4819133	PAUSE stopper	49	4839379	FF gear	86	4819528	Head base
14	4850692	Button lever spring	50	4839370	Back tension spring	87	4831623	Operation lever
15	4820215	SUB chassis	51	4842431	Supply reel assy	88	4831624	B frame
16	4819007	Button lever spring	52	4839381	TAKE UP reel assy	89	4819232	Button lever shaft
17	4820217	PLAY button lever spring	53	4832421	Record safety lever	90	4819072	Screw (2x7)
18	4831614	Head panel	54	4839382	Back tension spring	91	4833463	Lever
19	4819008	Actuator spring	55	4835915	Motor bracket	92	4833464	Lever
20	4819009	AUTO lever	56	4819039	Motor rubber	93	4833465	Special screw
21	4819000	AUTO lever spring	57	4819533	Motor collar screw	94	4833460	Collar (B)
22	4820214	Button lever spring	59	4833457	Belt	95	4833467	Spring
23	4832091	Leaf switch	60	4848086	Mat	96	4832102	Switch leaf
24	4832522	Screw	61	4833452	Record plate	97	4833468	Collar
25	4820219	Head panel	62	4819043	Eject slide lever	98	4850699	Lever
26	4832451	RWD button lever	63	4819044	Eject slide lever spring	99	4835917	Switch bracke
27	4819014	Head base	64	4819036	Pack spring	100	4468971	REC lever (A)
28	4832412	Sensing plate assy	65	2557522	P head	101	4850690	Leaf switch
29	4832452	FF button lever	66	2557521	R/P head	102	4850694	Leaf switch
30	4820221	Head panel	67	2557531	E head	103	4819195	Tapping screw (2x5)
31	4832482	SUB plate	68	4831657	Motor assy	104	4833472	Tapping screw (2x6)
32	4819006	PR stopper	69	4820218	Switch actuator spring	105	4691911	Counter belt
33	4819045	Screw	70	4819186	Screw (2x3)	106	4819529	E.H. spring
34	4819017	Spring	71	4819063	Tapping screw (2x3)	107	4850702	Washer (2.4)
35	4839372	Pinch roller arm assy	72	4819068	Tapping screw (2x4)	108	4819544	Cap screw (2x8)
			73	4819607	Bind tapping screw (2x5)			

Player (HT-MD28)

SYMBOL NO.	PART NO.	DESCRIPTION	SYMBOL NO.	PART NO.	DESCRIPTION	SYMBOL NO.	PART NO.	DESCRIPTION
1	4817521	EP adaptor	19	4835682	Pendulum	37	4835716	Spring
2	4835737	Cam gear assy	20	4835683	Hinge assy	38	4835717	Spring
3	4835738	Platter assy	21	4835743	Motor assy	39	4835718	Spring
4	4835739	Return link assy	22	4835693	Micro switch	40	4835719	Steel cramper
5	4835665	Starting lever	23	4835694	Push switch	41	4835721	Spring
6	4835730	Pick-up stand assy	24	4835697	DC board	42	4835723	Pendulum
7	4835741	Tone arm assy	25	4835695	5P Connector ass'y	43	4835724	Belt
8	4835668	Knob shaft	26	4835696	P.C. board	44	4835725	Rubber tube
9	4835669	Oil shaft	27	4835703	Screw	45	4835726	Rubber foot (L)
10	4835660	Press set	28	4835704	Screw	46	4835728	Rubber mat
11	4835671	Lifter	29	4835706	Screw	47	4817549	Washer
12	4835675	Pendulum set	30	4835707	Screw	48	4835729	Washer
13	3307471	Push button	31	4835708	Screw	49	4817557	Washer
14	3307461	Push button	32	4835709	Screw	50	4835731	Washer
15	4835745	Dust cover assy	33	4835700	Screw	51	4835734	Washer
16	4835676	Platter shaft assy	34	4835712	Screw	52	4835735	Washer
17	4835670	Press plate	35	4835713	Screw	53	4835736	Steel ball
18	4835681	Hanging plate for motor	36	4835715	Screw	54	4850561	Player base assy

**HITACHI SALES EUROPA GmbH**

Postfach 801060 Rungedamm 2, 2050 Hamburg 80,
West Germany
Tel. 040-734 11-0

HITACHI SALES (U.K.) Ltd.

Hitachi House, Station Road, Hayes, Middlesex UB3
4DR, England
Tel. 01-848-8787

HITACHI SALES SCANDINAVIA AB

Rissneleden 8, Box 7138, 172-07 Sundbyberg, Sweden
Tel. 08-98 52 80

HITACHI SALES NORWAY A/S

Oerebekk 1620, Gressvik, P.O. Box 46, N-1601,
Fredrikstad, Norway
Tel. 032-28255

SUOMEN HITACHI OY

Takojankatsu 5, 15800 Lahti 80, Finland
Tel. Lahti 44 241

HITACHI SALES A/S

Kuldysen 13, DK-2630, Taastrup, Denmark
Tel. 02-999200

HITACHI SALES A.G.

Bahnhofstrasse, 19, 5600 Lenzburg, Switzerland
Tel. 064-513621

HITACHI SALES WARENHANDELS GMBH

A-1180/Wien, Kreuzgasse 27, Austria
Tel. 0222-439367

HITACHI SALES ITALIANA, S.P.A.

Via Cristoforo Colombo 49, Trezzano sul naviglio
(Milano), Italy
Tel. 02-44 59 031

HITACHI SALES BELGIUM S.A.

56, Chaussee de Namur B-1400 Nivelles, Belgium
Tel. (003267) 227181

HITACHI SALES IBERICA, S.A.

Gran Via Carlos Tercero, 101, 1-1, Barcelona-28,
Spain
Tel. 330-8652

HITACHI MAROC (RADIO TV ELECTRO-MANAGER), S.A.

Rue du Havre, Casablanca, Morocco
Tel. 30-73-68, 30-73-57

HITACHI CANARIAS S.A.

Calle San-Francisco No. 19, Santa Cruz de Tenerife
Canary Islands
Tel. 24-64-98

HITACHI SALES (HELLAS) LTD.

110 Syngrou St., Athens, Greece
Tel. 9219082, 9233469

HITACHI SALES (MALAYSIA) SDN, BHD.

17, Jalan 20/16, Petaling Jaya, Selangor, Malaysia
Tel. 762523, 769918, 769836, 762594

HITACHI (SINGAPORE) PTE., LTD.

Room B, C & D, 15th Floor, Yen San Building
268 Orchard Road, Singapore 9, Singapore
Tel. 7378244, 7379826

HITACHI SALES (THAILAND) LTD.

2242-48, New Petchburi Road, Bangkok, Hueykuang
Bangkok, Thailand
Tel. 314-2741

HITACHI ELECTRIC SERVICE CO., (HONG KONG) LTD.

4th Floor Leun Tai Industrial Bldg., 72-76 Kwai Cheong
Road Kwai Chung N.T., Hong Kong
Tel. 240126

HITACHI SALES AUSTRALIA PTY LTD.

153 Keys Road, Moorabbin, Victoria 3189 Australia
Tel. 555-8722

HITACHI SALES CORPORATION OF AMERICA

Eastern Regional Office
1290 Wall Street West, Lyndhurst, New Jersey 07071,
U.S.A.
Tel. 201-935-8980

Mid-Western Regional Office

1400 Morse Ave., Elk Grove Village, Ill. 60007, U.S.A.
Tel. 312-593-1550

Southern Regional Office

510 Plaza Drive, College Park, Georgia 30349, U.S.A.
Tel. 404-763-0360

Western Regional Office

401 West Artesia Boulevard, Compton, California 90220
U.S.A.

Tel. 213-537-8383

HITACHI SALES CORPORATION OF HAWAII, INC.

3219 Koapaka Street, Honolulu, Hawaii 96819, U.S.A.
Tel. 808-836-3621

HITACHI (HSC) CANADA INC.

3300 Trans-Canada Highway, Pointe Claire, Quebec,
H9R 1B1, Canada
Tel. 514-697-9150

Hitachi Sales Centroamericana, S.A.

San Rafael de Escazu, (Apartado 10272), San Jose,
Costa Rica
Tel. 28-20-11, 28-00-37

Hitachi Sales Corporation de Panama, S.A.

Nuevo Reparto E1 Carmen, Calle Ramon Arias y Calle B
Edificio Brasil 100, (Apartado 7657) Panama 5
Panama City, Rep. of Panama
Tel. 61-3100, 61-4305

Hitachi Sales de Chile Cia., Ltda.

Av. Mexico, 0183, Casilla 9793, Correo Central
Santiago, Chile
Tel. 774165

HITACHI-FRANCE S.A.

95-101 Rue Charles Michels,
93200 SAINT-DENIS,
France
Tel. 1-4821-6015

HITACHI LTD. TOKYO JAPAN

Head Office: THE HITACHI ATAGO BLDG.
No. 15-12, 2-Chome Nishi-Shinbashi
Minato-ku, Tokyo 105, Japan
Tel. Tokyo (03) 502-2111

MD18/MD28 7Y No. 563 EF